

*To our families and patients who have supported our efforts to advance the care of asthma, allergy, and immunology treatment for children. We would also like to thank those children and families who participated in studies that allowed us to make the changes in care emphasized in this update.*

# Pediatric Allergy

## PRINCIPLES AND PRACTICE

*Third Edition*

**Donald Y. M. Leung MD  
PhD FAAAAI**

Professor of Pediatrics  
University of Colorado  
Edelstein Family Chair of Pediatric Allergy-  
Clinical Immunology  
National Jewish Health  
Denver, CO, USA

**Stanley J. Szefler MD**

Director, Pediatric Asthma Research Program  
Breathing Institute  
Section of Pediatric Pulmonary Medicine  
Children's Hospital Colorado  
Professor of Pediatrics  
University of Colorado Denver School  
of Medicine  
Aurora, CO, USA

**Francisco A. Bonilla MD PhD**

Associate Professor of Pediatrics  
Harvard Medical School  
Director, Clinical Immunology Program  
Division of Immunology  
Boston Children's Hospital  
Boston, MA, USA

**Cezmi A. Akdis MD**

Professor of Immunology  
Director  
Swiss Institute of Allergy and Asthma  
Research (SIAF)  
University of Zurich  
Davos, Switzerland  
Director (Speaker)  
Christine Kühne – Center for Allergy  
Research and Education (CK-CARE)  
Chair iCAAAL  
International Coalition on Allergy Asthma  
and Immunology

**Hugh A. Sampson MD**

Kurt Hirschhorn Professor of Pediatrics  
Dean for Translational Biomedical Sciences  
Director, Conduits (Mount Sinai's CTSA  
Program)  
Director, Jaffe Food Allergy Institute  
Department of Pediatrics  
Icahn School of Medicine at Mount Sinai  
New York, NY, USA

For additional online content visit [expertconsult.inkling.com](http://expertconsult.inkling.com)

ELSEVIER

Edinburgh London New York Oxford Philadelphia St Louis Sydney Toronto 2016



# ELSEVIER

© 2016, Elsevier Inc. All rights reserved.

First edition 2003

Second edition 2010

Third edition 2016

No part of this publication may be reproduced or transmitted in any form or by any means, electronic or mechanical, including photocopying, recording, or any information storage and retrieval system, without permission in writing from the publisher. Details on how to seek permission, further information about the Publisher's permissions policies and our arrangements with organizations such as the Copyright Clearance Center and the Copyright Licensing Agency, can be found at our website: [www.elsevier.com/permissions](http://www.elsevier.com/permissions).

This book and the individual contributions contained in it are protected under copyright by the Publisher (other than as may be noted herein).

## Notices

Knowledge and best practice in this field are constantly changing. As new research and experience broaden our understanding, changes in research methods, professional practices, or medical treatment may become necessary.

Practitioners and researchers must always rely on their own experience and knowledge in evaluating and using any information, methods, compounds, or experiments described herein. In using such information or methods they should be mindful of their own safety and the safety of others, including parties for whom they have a professional responsibility.

With respect to any drug or pharmaceutical products identified, readers are advised to check the most current information provided (i) on procedures featured or (ii) by the manufacturer of each product to be administered, to verify the recommended dose or formula, the method and duration of administration, and contraindications. It is the responsibility of practitioners, relying on their own experience and knowledge of their patients, to make diagnoses, to determine dosages and the best treatment for each individual patient, and to take all appropriate safety precautions.

To the fullest extent of the law, neither the Publisher nor the authors, contributors, or editors, assume any liability for any injury and/or damage to persons or property as a matter of products liability, negligence or otherwise, or from any use or operation of any methods, products, instructions, or ideas contained in the material herein.

ISBN: 978-0-323-29875-9

eISBN: 978-0-323-33946-9

*Content Strategist:* Belinda Kuhn

*Content Development Specialist:* Nani Clansey

*Content Coordinator:* Sam Crowe/Trinity Hutton

*Project Manager:* Joanna Souch

*Design:* Miles Hitchen

*Illustration Manager:* Emily Constantino

*Illustrator:* Victoria Heim

*Marketing Manager(s) (UK/USA):* Kristin Koehler

Printed in China

Last digit is the print number: 9 8 7 6 5 4 3 2 1



Working together  
to grow libraries in  
developing countries

[www.elsevier.com](http://www.elsevier.com) • [www.bookaid.org](http://www.bookaid.org)

# LIST OF CONTRIBUTORS

## **Mark J. Abzug, MD**

Professor of Pediatrics  
Associate Vice Chair for Academic Affairs  
Department of Pediatrics  
University of Colorado School of Medicine  
Children's Hospital Colorado  
Aurora, CO, USA

## **Cezmi A. Akdis, MD**

Professor of Immunology  
Director  
Swiss Institute of Allergy and Asthma Research (SIAF)  
University of Zurich  
Davos, Switzerland  
Director (Speaker)  
Christine Kühne – Center for Allergy Research and Education  
(CK-CARE)  
Chair iCAAAL  
International Coalition on Allergy Asthma and Immunology

## **Katrina Allen, MBBS BMedSc FRACP FAAAAI PhD**

Theme Director, Population Health, MCRI  
Director, NHMRC Centre of Food and Allergy Research  
Paediatric Gastroenterologist/Allergist, RCH  
Professor of Paediatrics, University of Melbourne  
Murdoch Children's Research Institute  
The Royal Children's Hospital  
Victoria, VIC, Australia

## **Leonard B. Bacharier, MD**

Professor of Pediatrics & Medicine  
Washington University School of Medicine  
St. Louis Children's Hospital  
St. Louis, MO, USA

## **Mark Ballow, MD**

Professor of Pediatrics  
Division of Allergy and Immunology  
Department of Pediatrics  
University of South Florida/Morsani College of Medicine, All  
Children's Hospital  
St Petersburg, FL, USA

## **Ashton Bartholow, BS**

Research Assistant  
Allegheny Singer Research Institute  
Pittsburgh, PA, USA

## **Allan Becker, MD FRCPC**

Professor and Head  
Section of Allergy and Clinical Immunology  
Department of Pediatrics and Child Health  
University of Manitoba  
Winnipeg, MB, Canada

## **Edward M. Behrens, MD**

Assistant Professor of Pediatrics  
Department of Pediatrics  
Joseph Lee Hollander Chair in Pediatric Rheumatology  
Perelman School of Medicine at The University of  
Pennsylvania  
Chief of Pediatric Rheumatology  
The Children's Hospital of Philadelphia  
Philadelphia, PA, USA

## **Bruce G. Bender, PhD**

Professor and Head  
Pediatric Behavioral Health  
National Jewish Health  
Denver, CO, USA

## **M. Cecilia Berin, PhD**

Associate Professor of Pediatrics  
Division of Allergy and Immunology  
Icahn School of Medicine at Mount Sinai  
New York, NY, USA

## **Brett P. Bielory, MD**

Resident  
Department of Ophthalmology  
New York Medical College  
Westchester Medical Center  
Valhalla, NY, USA

## **Leonard Bielory, MD FAAAAI FAAAAI FACP**

Professor  
Rutgers University  
RobertWood Johnson University Hospital  
Environmental and Occupational Health Sciences Institute  
University Asthma and Allergy Associates  
Springfield, NJ, USA

## **S. Allan Bock, MD**

Clinical Professor  
Department of Pediatrics  
National Jewish Health  
Denver, Colorado, USA  
Department of Pediatrics  
University of Colorado  
Denver School of Medicine  
Denver, CO, USA

## **Mark Boguniewicz, MD**

Professor, Division of Allergy-Immunology  
Department of Pediatrics  
National Jewish Health  
University of Colorado School of Medicine  
Denver, CO, USA



**Francisco A. Bonilla, MD PhD**

Associate Professor of Pediatrics  
Harvard Medical School  
Director, Clinical Immunology Program  
Division of Immunology  
Boston Children's Hospital  
Boston, MA, USA

**A. Wesley Burks, MD**

Executive Dean, School of Medicine  
Curnen Distinguished Professor and Chair  
Department of Pediatrics  
The University of North Carolina  
Chapel Hill, NC, USA

**Andrew Bush, MB BS (Hons) MA MD FRCP  
FRCPCH FERS**

Professor of Paediatrics and Head of Section (Paediatrics),  
Imperial College  
Professor of Paediatric Respiriology  
National Heart and Lung Institute  
Consultant Paediatric Chest Physician  
Royal Brompton Harefield NHS Foundation Trust  
London, UK

**Kenny H. Chan, MD**

Professor of Otolaryngology  
University of Colorado  
School of Medicine  
Children's Hospital Colorado  
Aurora, Colorado, USA

**Mirna Chehade, MD MPH**

Associate Professor of Pediatrics and Medicine  
Director, Mount Sinai Center for Eosinophilic Disorders  
Jaffe Food Allergy Institute  
Icahn School of Medicine at Mount Sinai  
New York, NY, USA

**Anca M. Chiriac, MD**

Assistant Professor  
Allergy Unit, Département de Pneumologie et Addictologie  
Hôpital Arnaud de Villeneuve  
University Hospital of Montpellier  
Montpellier, France  
UMR-S 1136 INSERM, IPLESP, UPMC Paris 06, Sorbonne  
Universités  
Paris, France

**Lisa Cicutto, RN ACNP(cert) PhD CAE**

Director  
Community Outreach and Research, National Jewish Health  
Director  
Clinical Science Program, University of Colorado Denver  
AMC  
Denver, Colorado, USA

**Samuel A. Collins, MA MB BS MRCPCH**

Clinical Research Fellow  
Clinical and Experimental Sciences  
University of Southampton  
Southampton, UK

**Ronina A. Covar, MD**

Associate Professor  
Department of Pediatrics  
National Jewish Health  
University of Colorado "School of Medicine"  
Denver, CO, USA

**Benjamin P. Davis, MD**

Cincinnati Children's Hospital Medical Center  
Division of Allergy and Immunology  
Cincinnati, OH, USA

**Fatma Dedeoglu, MD**

Assistant Professor of Pediatrics  
Harvard Medical School  
Division of Immunology  
Rheumatology Program  
Boston Children's Hospital  
Boston, MA, USA

**Pascal Demoly, MD PhD**

Professor and Head  
Allergy Unit, Département de Pneumologie et Addictologie,  
Hôpital Arnaud de Villeneuve  
University Hospital of Montpellier  
Montpellier, France  
UMR-S 1136 INSERM, IPLESP, UPMC Paris 06, Sorbonne  
Universités,  
Paris, France

**Peyton A. Eggleston, MD**

Professor Emeritus  
Division of Pediatric Allergy and Immunology  
Johns Hopkins University School of Medicine  
Baltimore, MD, USA

**Robert Eisenberg, MD**

Professor of Medicine, Emeritus  
Department of Medicine  
Perelman School of Medicine at the University of  
Pennsylvania  
Philadelphia, PA, USA

**Thomas A. Fleisher, MD**

Chief, Department of Laboratory Medicine  
NIH Clinical Center  
National Institutes of Health  
Bethesda, MD, USA

**Luz Fonacier, MD**

Professor of Medicine  
State University of New York at Stony Brook  
Head of Allergy and Training Program Director  
Winthrop University Hospital  
Mineola, NY, USA

**Deborah A. Gentile, MD**

Director of Research  
Division of Allergy, Asthma, and Immunology Allegheny  
General Hospital Pittsburgh, PA, USA  
Professor of Medicine Temple University School of Medicine  
Philadelphia, PA, USA

**James E. Gern, MD**

Professor of Pediatrics and Medicine  
Divisions of Allergy and Immunology  
University of Wisconsin School of Medicine and Public  
Health  
Madison, WI, USA

**Marion Groetch, MS RDN**

Director of Nutrition Services  
Jaffe Food Allergy Institute  
Kravis Children's Hospital  
Icahn School of Medicine at Mount Sinai  
New York, NY, USA

**Susanne Halcken, MD DMSci**

Professor  
Consultant in Pediatric Allergology  
Hans Christian Andersen Children's Hospital,  
Odense University Hospital  
Odense C, Denmark

**Robert G. Hamilton, PhD D(AMBLI) FAAAAI**

Professor of Medicine and Pathology  
Director, Johns Hopkins Dermatology, Allergy and Clinical  
Immunology Reference Laboratory  
Johns Hopkins University School of Medicine  
Baltimore, MD, USA

**Elysia M. Hollams, PhD**

Senior Research Officer  
Division of Cell Biology  
Telethon Kids Institute,  
University of Western Australia,  
Perth, WA, Australia

**Steven M. Holland, MD**

Chief, Laboratory of Clinical Infectious Diseases  
National Institutes of Allergy and Infectious Diseases, NIH  
Bethesda, MD, USA

**John W. Holloway, PhD**

Professor of Respiratory and Allergy Genetics  
Human Development and Health  
University of Southampton  
Southampton, UK

**Patrick G. Holt, DSc FAA**

Professor  
Telethon Kids Institute, University of Western Australia, Perth,  
Australia,  
Queensland Children's Medical Research Institute,  
University of Queensland, Brisbane, Australia.

**Arne Høst, MD DMSci**

Associate Professor  
Head of Department of Pediatrics  
Hans Christian Andersen Children's Hospital  
Odense University Hospital  
Odense C, Denmark

**Daniel J. Jackson, MD**

Assistant Professor  
Department of Pediatrics  
Section of Allergy, Immunology & Rheumatology  
University of Wisconsin-Madison  
Madison, WI, USA

**Stacie M. Jones, MD**

Professor of Pediatrics  
Chief, Allergy and Immunology  
Dr. and Mrs. Leeman King Chair in Pediatric Allergy  
University of Arkansas for Medical Sciences  
Arkansas Children's Hospital  
Little Rock, AR, USA

**Meyer Kattan, MD CM**

Professor of Pediatrics at Columbia University Medical Center  
Director, Pediatric Pulmonary Division  
Department of Pediatrics  
Columbia University College of Physicians and Surgeons  
New York, NY, USA

**Brian T. Kelly, MD MA**

Instructor and Fellow, Department of Pediatrics  
Division of Allergy/Immunology  
Medical College of Wisconsin  
Milwaukee, WI, USA

**Kevin J. Kelly, MD**

Professor of Pediatrics  
Vice Chair of Clinical Operations  
University of North Carolina  
Pediatrician in Chief  
North Carolina Children's Hospital  
Chapel Hill, NC, USA

**Susan Kim, MD MMSc**

Instructor of Pediatrics  
Division of Immunology  
Rheumatology Program  
Harvard University  
Boston Children's Hospital  
Boston, MA, USA

**Donald B. Kohn, MD**

Professor  
Departments of Microbiology, Immunology & Molecular  
Genetics and Pediatrics  
David Geffen School of Medicine and Mattel Children's  
Hospital  
University of California, Los Angeles  
Los Angeles, CA, USA

**Howard M. Lederman, MD PhD**

Professor of Pediatrics, Medicine and Pathology  
Eudowood Division of Pediatric Allergy and Immunology  
Johns Hopkins University School of Medicine  
Baltimore, MD, USA



**Heather K. Lehman, MD**

Clinical Associate Professor of Pediatrics  
 Division of Allergy, Immunology and Rheumatology  
 Department of Pediatrics  
 Women and Children's Hospital of Buffalo  
 University of Buffalo School of Medicine and Biomedical  
 Sciences  
 Buffalo, NY, USA

**Robert F. Lemanske Jr, MD**

Professor of Pediatrics and Medicine  
 Head, Division of Pediatric Allergy, Immunology and  
 Rheumatology  
 University of Wisconsin School of Medicine and Public  
 Health  
 Madison, WI, USA

**Donald Y.M. Leung, MD PhD FAAAAI**

Professor of Pediatrics  
 University of Colorado  
 Edelstein Family Chair of Pediatric Allergy-Clinical  
 Immunology  
 National Jewish Health  
 Denver, CO, USA

**Chris A. Liacouras, MD**

Professor of Pediatrics Gastroenterology  
 Perlman School of Medicine at the University of Pennsylvania  
 School of Medicine  
 Division of GI & Nutrition  
 The Children's Hospital of Philadelphia  
 Philadelphia, PA, USA

**Andrew H. Liu, MD**

Professor of Pediatrics  
 Allergy and Clinical Immunology  
 National Jewish Health  
 Children's Hospital Colorado  
 University of Colorado School of Medicine  
 Denver, CO, USA

**Gabrielle A. Lockett, PhD**

Post-doctoral Research Fellow  
 Human Development and Health  
 University of Southampton  
 Southampton, UK

**Jonathan E. Markowitz, MD MSCE**

Medical Director, Pediatric Gastroenterology  
 Greenville Health System  
 Professor of Clinical Pediatrics  
 University of South Carolina School of Medicine – Greenville  
 Greenville, SC, USA

**Fernando D. Martinez, MD**

Regents' Professor  
 Director, Arizona Respiratory Center  
 Director, BIO5 Institute  
 Swift-McNear Professor of Pediatrics  
 University of Arizona  
 Tucson, AZ, USA

**Elizabeth C. Matsui, MD MHS**

Associate Professor  
 Division of Pediatric Allergy and Immunology  
 Johns Hopkins University School of Medicine  
 Baltimore, MD, USA

**Bruce D. Mazer, MD**

Professor of Pediatrics  
 Head of Child Health Research  
 Deputy Executive Director  
 The Research Institute of the McGill University Health Center  
 Montreal Children's Hospital  
 Montreal, QC, Canada

**Henry Milgrom, MD**

Professor of Pediatrics  
 National Jewish Health  
 University of Colorado School of Medicine  
 Denver, CO, USA

**Amanda B. Muir, MD**

Instructor of Pediatrics  
 Perlman School of Medicine at the University of Pennsylvania  
 School of Medicine  
 Division of GI & Nutrition  
 The Children's Hospital of Philadelphia  
 Philadelphia, PA, USA

**Harold S. Nelson, MD**

Professor of Medicine  
 National Jewish Health and  
 University of Colorado Denver School of Medicine  
 Denver, CO, USA

**David P. Nichols, MD**

Division Head, Pediatric Pulmonology  
 National Jewish Health  
 Associate Professor of Pediatrics  
 University of Colorado School of Medicine  
 Denver, CO, USA

**Luigi D. Notarangelo, MD**

Prince Turki Bin Abdul-AzizAl-Saud Professor of Pediatrics  
 Harvard Medical School  
 Division of Immunology  
 Boston Children's Hospital  
 Boston, MA, USA

**Natalija Novak, MD**

Professor of Dermatology  
 Department of Dermatology and Allergy  
 University of Bonn  
 Bonn, Germany

**Anna Nowak-Węgrzyn, MD**

Associate Professor of Pediatrics  
 Jaffe Food Allergy Institute  
 Kravis Children's Hospital  
 Icahn School of Medicine at Mount Sinai  
 New York, NY, USA

**Hans C. Oettgen, MD PhD**

Professor of Pediatrics  
Boston Children's Hospital  
Harvard Medical School  
Boston, MA, USA

**J. Tod Olin, MD MSCS**

Assistant Professor  
Department of Pediatrics, Division of Pulmonology  
Director, Pediatric Exercise Tolerance Center  
National Jewish Health  
Denver, CO, USA

**Joao Bosco Oliveira, MD PhD**

Staff Clinician/Assistant Director  
Department of Laboratory Medicine  
NIH Clinical Center  
National Institutes of Health  
Bethesda, MD, USA

**Hanneke (Joanne) N.G. Oude Elberink, MD PhD**

Associate Professor of Medicine  
Director Dutch Mastocytosis Center Groningen  
Department of Allergology and Internal Medicine  
Groningen Research Institute of Asthma and COPD  
University Medical Center Groningen  
University of Groningen  
Groningen, The Netherlands

**Oscar Palomares, PhD**

Ramón y Cajal (RyC) Research Associated  
Department of Biochemistry and Molecular Biology  
School of Chemistry  
Complutense University of Madrid  
Madrid, Spain

**Wanda Phipatanakul, MD MS**

Associate Professor of Pediatrics  
Division of Immunology  
Boston Children's Hospital  
Harvard Medical School  
Boston, MA, USA

**Nicole Pleskovic, BS**

Research Assistant  
Division of Allergy, Asthma, and Immunology Allegheny  
General Hospital  
Pittsburgh, PA, USA

**Susan Prescott, BMedSc FRACP PhD MD**

Winthrop Professor  
School of Paediatrics and Child Health  
University of Western Australia  
Paediatric Allergist, Perth Children's Hospital  
Research Strategy Leader, Telethon KIDS Institute  
Perth, WA, Australia

**Sergio D. Rosenzweig, MD PhD**

Director, Primary Immunodeficiency Clinic, NIAID;  
Deputy Chief, Immunology Service, DLM, Clinical Center,  
NIH, Bethesda, MD, USA

**Marc E. Rothenberg, MD PhD**

Professor of Pediatrics  
Director, Division of Allergy and Immunology  
Director, Cincinnati Center for Eosinophilic Disorders  
Cincinnati Children's Hospital Medical Center  
Cincinnati, OH, USA

**Hugh A. Sampson, MD**

Kurt Hirschhorn Professor of Pediatrics  
Dean for Translational Biomedical Sciences  
Director, Conduits (Mount Sinai's CTSA Program)  
Director, Jaffe Food Allergy Institute  
Department of Pediatrics  
Icahn School of Medicine at Mount Sinai  
New York, NY, USA

**William J. Sheehan, MD**

Instructor of Pediatrics  
Harvard Medical School  
Division of Immunology  
Boston Children's Hospital  
Boston, MA, USA

**Scott H. Sicherer, MD**

Elliot and Roslyn Jaffe Professor of Pediatrics, Allergy and  
Immunology  
Division Chief, Pediatric Allergy and Immunology  
Jaffe Food Allergy Institute  
Kravis Children's Hospital  
Icahn School of Medicine at Mount Sinai  
New York, NY, USA

**F. Estelle R. Simons, MD FRCPC FAAP FAAAAI FCAHS**

Professor  
Department of Pediatrics & Child Health  
Professor, Department of Immunology  
The University of Manitoba  
Winnipeg, MB, Canada

**David P. Skoner, MD**

Professor of Medicine  
Temple University School of Medicine  
Philadelphia, PA, USA  
Clinical Professor of Pediatrics  
West Virginia University School of Medicine Morgantown,  
WV, USA  
Director, Division of Allergy, Asthma, and Immunology  
Department of Medicine Allegheny General Hospital  
Pittsburgh, PA, USA

**Joseph D. Spahn, MD**

Associate Professor of Pediatrics  
Division of Allergy/Clinical Immunology  
National Jewish Health  
Denver, CO, USA

**Robert C. Strunk, MD**

Strominger Professor of Pediatrics  
Washington University School of Medicine  
St. Louis Children's Hospital  
St. Louis, MO, USA



**Kathleen E. Sullivan, MD PhD**

Professor of Pediatrics  
The Children's Hospital of Philadelphia  
University of Pennsylvania Perelman School of Medicine  
Philadelphia, PA, USA

**Robert P. Sundel, MD**

Director of Rheumatology  
Boston Children's Hospital  
Associate Professor of Pediatrics  
Harvard Medical School  
Boston, MA, USA

**Stanley J. Szeffler, MD**

Director, Pediatric Asthma Research Program  
Breathing Institute  
Section of Pediatric Pulmonary Medicine  
Children's Hospital Colorado  
Professor of Pediatrics  
University of Colorado Denver School of Medicine  
Aurora, CO, USA

**Troy R. Torgerson, MD PhD**

Associate Professor  
Pediatrics, Immunology/Rheumatology  
University of Washington  
Seattle Children's Hospital  
Seattle, WA, USA

**Erika von Mutius, MD MSc**

Professor of Pediatric Allergology  
Dr. von Hauner Children's Hospital  
Ludwig Maximilian-University of Munich  
Munich, Germany

**Rudolph S. Wagner, MD**

Clinical Professor of Ophthalmology  
Director of Pediatric Ophthalmology  
Institute of Ophthalmology and Visual Science  
Rutgers – New Jersey Medical School  
Newark, NJ, USA

**Julie Wang, MD**

Associate Professor of Pediatrics  
Jaffe Food Allergy Institute  
Kravis Children's Hospital  
Icahn School of Medicine at Mount Sinai  
New York, NY, USA

**Richard W. Weber, MD**

Professor of Medicine  
National Jewish Health  
University of Colorado School of Medicine  
Denver, CO, USA

**Robert A. Wood, MD**

Professor of Pediatrics  
Director, Pediatric Allergy and Immunology  
Johns Hopkins University School of Medicine  
Baltimore, MD, USA

**Bruce L. Zuraw, MD**

Professor of Medicine  
Chief, Division of Rheumatology, Allergy and Immunology  
Department of Medicine  
University of California San Diego  
La Jolla, CA, USA  
San Diego VA Healthcare  
San Diego, CA, USA

# PREFACE

These are exciting times for physicians who treat children with allergic and immunologically-mediated diseases. Microbial infection and treatment of allergic reactions are common problems seen by the practicing pediatrician. Recent studies have provided new insights into mechanisms underlying diseases in the area of pediatric allergy, asthma and clinical immunology. As a result, new therapies are targeting key immune pathways. Management guidelines for various diseases have also been developed based on evidence-based approaches. In addition, the National Institutes of Health have formed networks and collaborative studies to investigate allergic/immunologic diseases, such as food allergy, atopic dermatitis, asthma and immunodeficiency. We are now witnessing the introduction of new medications that resulted from improved understanding of the biology of allergic and immunologic diseases. The need to document and summarize this recent remarkable increase in information justifies the third edition of our textbook in the field of pediatric allergy and clinical immunology for practicing physicians and investigators interested in this area.

It is often said, 'Children are not simply small adults.' In no other subspecialty is this truer than in pediatric allergy and immunology, where the immune system and allergic responses are developing in different organs of the child. Earlier identification of disease onset offers special opportunities for prevention and intervention, which cannot be carried out once disease processes have been established in the older child and adult. Indeed, many diseases that pediatricians see in clinical practice are complex and are thought to result from a multigenic predisposition in combination with exposure to environmental triggers. However, the age at which the host is exposed to a particular environmental agent and the resultant immune response are increasingly being recognized as important factors. Furthermore, determining the appropriate time for intervention will be critical for defining a window of opportunity to induce disease remission. For example, microbes are a known trigger of established asthma in adults but the 'hygiene hypothesis' in children suggests that early exposure to certain microbes prior to the onset of allergies may actually prevent allergic responses and thus account for the low prevalence of allergic disease in children living on farms. New information is available on controlling asthma in early childhood, however our current treatment does not alter the natural history of the disease. This concept will now reach clinical care as we draw attention to population health and prevention.

*Pediatric Allergy: Principles and Practice* is aimed at updating the reader on the pathophysiology of allergic responses, and allergic diseases including asthma, food allergy, allergic rhinitis, and atopic dermatitis; their socioeconomic impact and new treatment approaches that take advantage of emerging concepts of the pathobiology of these diseases. An outstanding group of authors who are acknowledged leaders in their fields has been assembled because of their personal knowledge, expertise, and

involvement with their subject matter in children. Every effort has been made to achieve prompt publication of this book, thus ensuring that the content of each chapter is 'state of the art.'

Section A presents general concepts critical to an understanding of the impact and causes of allergic diseases. These include reviews of the epidemiology and natural history of allergic disease, genetics of allergic disease and asthma, biology of inflammatory-effector cells, regulation of IgE synthesis, and the developing immune system and allergy. Section B reviews an approach to the child with recurrent infection and specific immunodeficiency and autoimmune diseases that pediatricians frequently encounter. Section C updates the reader on a number of important and emerging immune-directed therapies including immunizations, immunoglobulin therapy, stem cell therapy, and gene therapy. Section D examines the diagnosis and treatment of allergic disease. The remainder of the book is devoted to the management and treatment of asthma and a number of specific allergic diseases such as upper airway disease, food allergy, allergic skin and eye diseases, drug allergy, latex allergy, insect hypersensitivity, and anaphylaxis. In each chapter, the disease is discussed in the context of its differential diagnoses, key concepts, evaluations, environmental triggers, and concepts of emerging and established treatments.

Major advances in this third edition include updates on genetics and biomarkers of allergy, inflammatory conditions and immunodeficiencies, recent guidelines in the treatment of asthma, food allergy, atopic dermatitis, urticaria-angioedema, and immunodeficiencies, population health, school-centered asthma programs, prevention strategies, appropriate evaluation of drug allergy and a better understanding of drug cross-reactivity to eliminate the difficulty prescribing antibiotics in the pediatric population, the role of new biologics and immunomodulatory therapy in the treatment of inflammatory diseases and emerging evidence that epithelial barrier dysfunction can drive allergic disease.

We would like to thank each of the contributors for their time and invaluable expertise, which were vital to the success of this book. The editors are also grateful to Belinda Kuhn (Senior Content Strategist), Joanna Souch (Project Manager) and Nani Clansey (Senior Content Development Specialist), who have played a major role in editing and organizing this textbook, as well as the production staff at Elsevier Ltd for their help in the preparation of this book.

*Donald Y. M. Leung, MD, PhD*

*Hugh A. Sampson, MD*

*Francisco A. Bonilla, MD, PhD*

*Cezmi A. Akdis, MD*

*Stanley J. Szefler, MD*

2015



# Epidemiology of Allergic Diseases

ERIKA VON MUTIUS

## KEY POINTS

- Large geographical variations in the prevalence of allergic diseases exist worldwide among children and adults.
- Lower prevalences have been reported from developing countries, eastern European areas, rural areas in Africa and Asia, and farm populations in Europe.
- The prevalence of asthma and allergies has increased over the last few decades. This trend seems to have reached a plateau in affluent countries, but not in low- to mid-income countries.
- Allergic diseases are multifactorial illnesses determined by a complex interplay between genetic and environmental factors.

## Introduction

Traditionally, asthma, allergic rhinitis and hay fever as well as atopic dermatitis and food allergy have been categorized as atopic diseases, yet the relation between clinical manifestations of these diseases and the production of IgE antibodies has not been fully clarified. Although in many patients high levels of total and specific IgE antibodies are found, many individuals in the general population will not show any signs of illness despite elevated total and specific IgE levels. In some individuals various atopic illnesses can be co-expressed, whereas in others only one manifestation of an atopic illness is present. The prevalence of these four atopic entities therefore only partially overlaps in the general population (Figure 1-1). Risk factors and determinants of atopy, defined as the presence of IgE antibodies, differ from those associated with asthma, atopic dermatitis and hay fever.

Asthma, atopic dermatitis and hay fever are complex diseases and their incidence is determined by an intricate interplay of genetic and environmental factors. Environmental exposures may affect susceptible individuals during certain time windows in which particular organ systems are vulnerable to extrinsic influences such as early in life. Moreover, most allergic illnesses are likely to represent syndromes with many different phenotypes rather than single disease entities. The search for determinants of allergic illnesses must therefore take phenotypes, genes, environmental exposures and the timing (developmental aspect) of these exposures into account.

## Prevalence of Childhood Asthma and Allergies

Asthma is a complex syndrome rather than a single disease entity. Different phenotypes with varying prognosis and determinants have been described, particularly over childhood years,

using hypothesis and data-driven approaches.<sup>1</sup> Transient wheezing is characterized by the occurrence of wheezing in infants up to the age of 2 to 3 years which disappears thereafter and does not progress to childhood asthma. There are epidemiological observations suggesting that these children may be at risk of developing chronic obstructive pulmonary disease (COPD) in adulthood. The main predictor of transient wheeze is pre-morbid reduced lung function, in part determined by passive smoke exposure in utero.<sup>1-4</sup> Wheeze among school-aged children can be classified into an atopic and nonatopic phenotype.<sup>5</sup> This differentiation has clinical implications as nonatopic children with wheeze outgrow their symptoms and retain normal lung function at school age. In turn, among atopic wheezy children, the time of new onset of atopic sensitization and the severity of airway responsiveness determine the progression of this wheezing phenotype over school and adolescent years.<sup>6</sup>

Data-driven latent class analyses of birth cohort studies have consistently shown a persistent phenotype with symptoms starting very early in life and progressing into school age and beyond.<sup>7</sup> Late onset and intermediate phenotypes have also been described. These phenotypes can only be identified in prospective studies following infants from birth, up to school age and through adolescence, enabling the differential analysis of risk factors and determinants for distinct wheezing phenotypes over time. These limitations must be borne in mind when discussing and interpreting findings from cross-sectional surveys. The relative proportion of different wheezing phenotypes is likely to vary among age groups and therefore the strength of association between different risk factors and wheeze is also likely to vary across age groups.

Similarly, limitations apply with respect to the epidemiology of atopic dermatitis.<sup>8</sup> The definition of atopic eczema varies from study to study and validations of questionnaire-based estimates have been few. Skin examinations by trained field workers, adding an objective parameter to questionnaire-based data, reflect a point prevalence of skin symptoms at the time of examination and can therefore, in only a limited way, corroborate estimates of lifetime prevalence.

Lastly, identified risk factors in all cross-sectional surveys relate to the prevalence of the condition. The prevalence in turn reflects the incidence and the persistence of a disease. It is therefore often difficult to disentangle aggravating from causal factors in such studies. Only prospective surveys can identify environmental exposures prior to the onset of an atopic illness and thus infer a potentially causal relationship to the new onset of disease.

## WESTERN VERSUS DEVELOPING COUNTRIES

In general, reported rates of asthma, hay fever and atopic dermatitis are higher in affluent, western countries than in developing countries. The worldwide prevalence of allergic diseases was assessed in the 1990s by the large scale International Study of

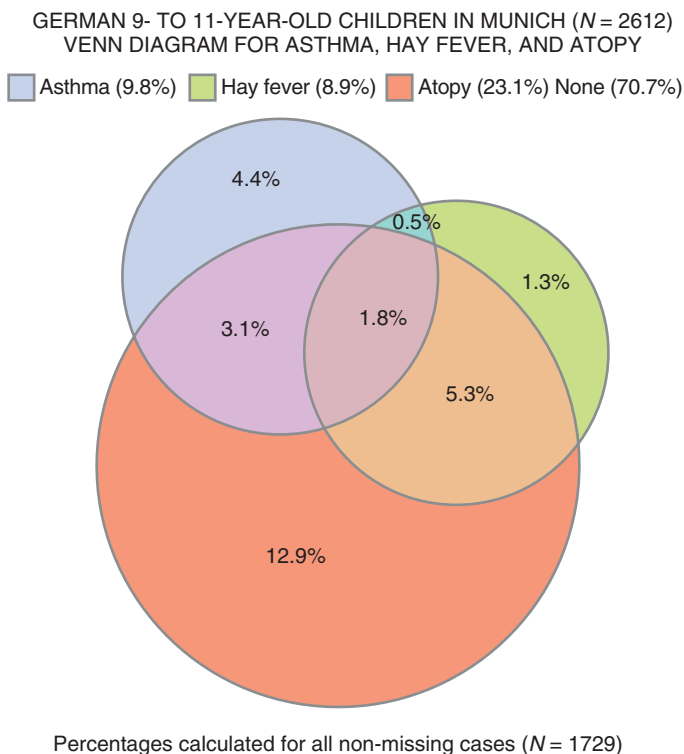

**Figure 1-1** The prevalence of asthma, hay fever and atopic sensitization only partially overlaps on a population level. Description of findings from the ISAAC Phase II study in Munich, of German children aged 9 to 11 years. (From *The International Study of Asthma and Allergies in Childhood [ISAAC]*. *Lancet* 1998;351:1225.)

Asthma and Allergy in Childhood (ISAAC).<sup>9</sup> A total of 463,801 children in 155 collaborating centers in 56 countries were studied. Between 20-fold and 60-fold differences were found between centers in the prevalence of symptoms of asthma, allergic rhinoconjunctivitis and atopic eczema (Figure 1-2).

The European Community Respiratory Health Survey (ECRHS) studied young adults aged 20 to 44 years.<sup>10</sup> A highly standardized and comprehensive study instrument including questionnaires, lung function and allergy testing was used by 35 to 48 centers in 22 countries, predominantly in Western Europe, but also in Australia, New Zealand and the USA. The ECRHS has shown large geographical differences in the prevalence of respiratory symptoms, asthma, bronchial responsiveness and atopic sensitization with high prevalence in English speaking countries and low prevalence rates in the Mediterranean region and Eastern Europe.<sup>11</sup> The geographical pattern emerging from questionnaire findings was consistent with the distribution of atopy and bronchial hyperresponsiveness, supporting the conclusion that the geographical variation in asthma is true and not attributable to methodological factors such as the questionnaire phrasing, the skin testing technique or the type of assay for the measurement of specific IgE.

A strong correlation was found between the findings from children as assessed by the ISAAC Study and the rates in adults as reported by the ECRHS questionnaire.<sup>12</sup> Although there were differences in the absolute prevalences observed in the two surveys, there was good overall agreement, adding support to the validity of both studies.

Dissociations between the prevalence of asthma and atopy have, however, been documented in developing countries.<sup>1,13,14</sup>

The ISAAC Phase II Study<sup>15</sup> has demonstrated that the fractions and prevalence rates of wheeze attributable to skin test reactivity correlated strongly with the gross national income of the respective country. These findings suggest that the strength of association between atopy and asthma across the world is determined by affluence and factors relating to affluence.

## THE EAST-WEST GRADIENT ACROSS EUROPE

A number of reports have been published demonstrating large differences in the prevalence of asthma, airway hyperresponsiveness, hay fever and atopy in children and adults between east and west European areas.<sup>16–20</sup> The prevalence of asthma was significantly lower in all study areas in eastern Europe compared to western Europe.<sup>17</sup> Among the older age group of 13- to 14-year-old children, the prevalence of wheezing was 11.2% to 19.7% in Finland and Sweden, 7.6% to 8.5% in Estonia, Latvia and Poland, and 2.6% to 5.9% in Albania, Romania, Russia, Georgia and Uzbekistan (except Samarkand).

The rates of allergic illnesses have been rising rapidly. After reunification of Germany in 1989 a significantly lower prevalence of allergic diseases was found in East Germany.<sup>16</sup> Only a few years later (2003–2006) differences in the prevalence rates between East and West Germany were no longer observed.<sup>21</sup> The causes underlying the increase in prevalence in East Germany are not fully understood. The drastic decrease in family size after reunification, changes in dietary habits or indoor exposures may have contributed to this trend. Likewise, Poland's accession to the European Union was followed by a rapid and striking increase in the prevalence of atopy in rural areas.<sup>22</sup> This increase may in part be attributable to loss of traditional farming exposures.

## DIFFERENCES BETWEEN RURAL AND URBAN POPULATIONS

The prevalence of asthma and allergies is not only increasing with westernization and affluence, but also with urbanization. The rates of asthma and atopy among children living in Hong Kong are similar to European figures. In rural China, asthma is almost nonexistent with a prevalence of less than 1%.<sup>23</sup> In Mongolia, a country in transition from rural, farming lifestyles to an industrial society, marked differences in the prevalence of asthma, allergic rhinoconjunctivitis and atopy exist.<sup>24</sup> Inhabitants of small rural villages are least affected, whereas residents of the capital city, Ulaanbaatar, have high rates of allergic diseases comparable to affluent western countries.

Across Europe, differences between urban and rural areas are less clear. However, strong contrasts exist on a lower spatial scale, i.e. among children raised on a farm in comparison to their neighbours living in the same rural area but not on a farm.<sup>25</sup> Since 1999, more than 30 studies have corroborated these findings.<sup>26</sup> Children raised on farms retain their protection from allergy at least into adulthood.<sup>27–29</sup>

The timing and duration of exposure seem to play a critical role. The largest reduction in risk of developing respiratory allergies is seen among those who are exposed prenatally and continue to be exposed throughout their life.<sup>30</sup> The protective factors in these farming environments have not been completely unraveled. Contact with farm animals, particularly cattle, confers protection. Also the consumption of unprocessed cow's milk has been shown to be beneficial with respect to childhood

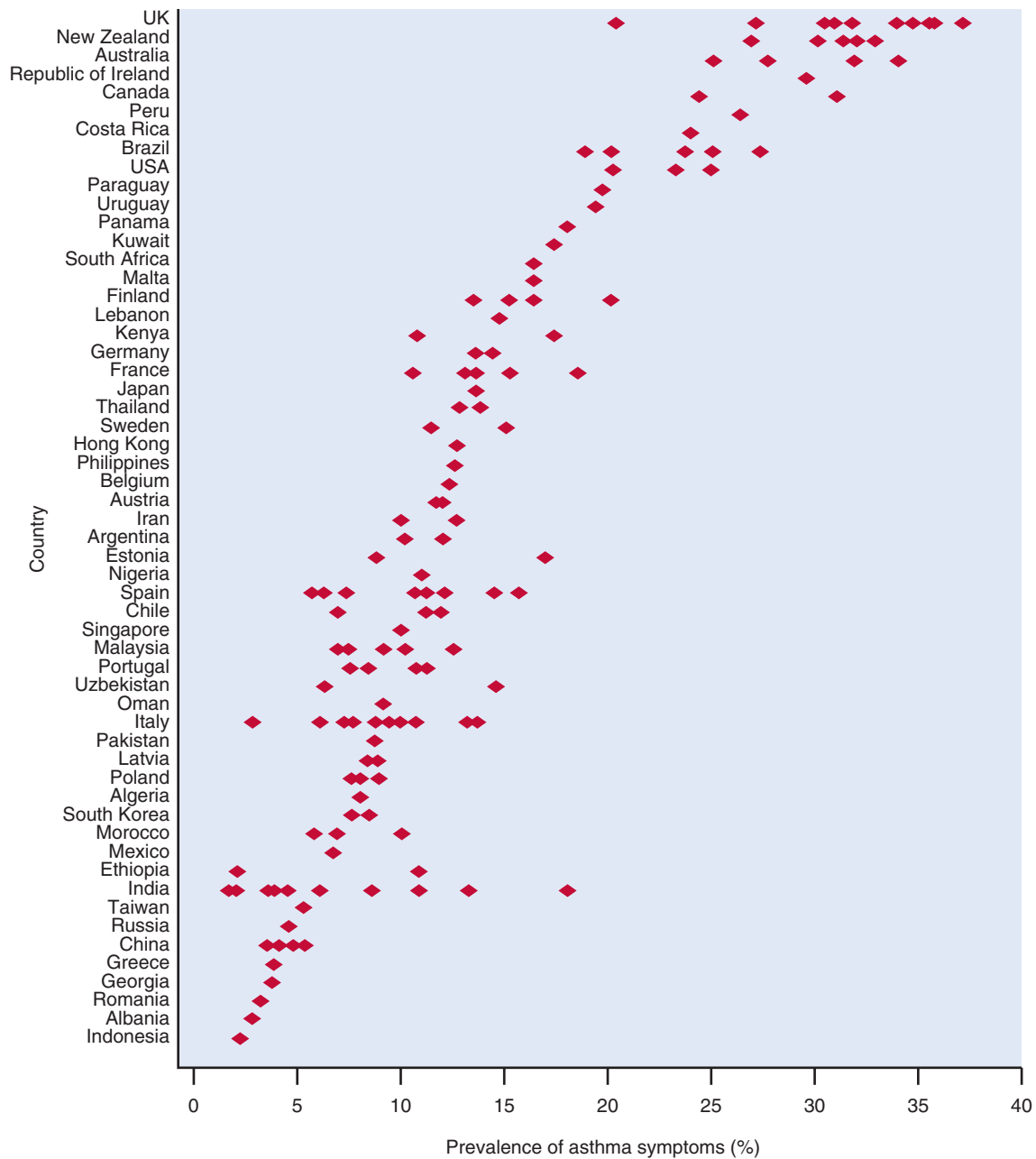

**Figure 1-2** Prevalence of asthma symptoms worldwide according to the ISAAC Phase I study. (From *The International Study of Asthma and Allergies in Childhood [ISAAC]*. *Lancet* 1998;351:1225.)

asthma and allergies. Increased levels and diversity of microbial exposures also contribute to the protective effects.<sup>31</sup>

### INNER CITY AREAS OF THE USA

Living conditions in inner city areas in the USA are associated with a markedly increased risk of asthma.<sup>32</sup> Several potential risk factors are being investigated, such as race and poverty, adherence to asthma treatment<sup>33</sup> and factors related to the disproportionate exposures associated with socioeconomic disadvantage such as indoor and outdoor exposure to pollution and cockroach infestation.<sup>4</sup> Cockroach exposure, at least in early life, has been associated with the development of sensitization to cockroach allergen<sup>34</sup> and wheeze<sup>35</sup> in infants living in inner city

areas of the USA. Problems relating to inner city asthma will be discussed in more detail in Chapter 33.

### Time Trends in the Prevalence of Allergic Diseases

Data collected over the last 40 years in industrialized countries indicate a significant increase in the prevalence of asthma, hay fever and atopic dermatitis in repeated cross-sectional surveys using identical questionnaires.<sup>36</sup> Most studies from industrialized countries suggest an overall increase in the prevalence of asthma and wheezing between 1960 and 1990. Many studies have been performed among children and little is

known about time trends in adults. Twenty-year trends of the prevalence of treated asthma among pediatric and adult members of a large US health maintenance organization were reported.<sup>37</sup> During the period 1967–1987, the treated prevalence of asthma increased significantly in all age-sex categories except males aged 65 and older. In the USA, the greatest increase was detected among children and young adults living in inner cities.<sup>38</sup>

Recent studies suggest that in some areas this trend may have reached a plateau. Studies from Italy showed that among school children surveyed in 1974, 1992 and 1998 the prevalence of asthma had increased significantly during the 1974–1992 period, whereas it remained stable from 1992 to 1998.<sup>39</sup> Similar findings have been reported from Germany and Switzerland, where prevalence rates have been on a plateau since the 1990s.<sup>40,41</sup> On a global scale, time trends in the prevalence of asthma and allergic rhinoconjunctivitis have been assessed in ISAAC Phase III.<sup>42</sup> The findings indicate that international differences in symptom prevalence have reduced with decreases in prevalence in English-speaking countries and Western Europe and increases in prevalence in regions where prevalence was previously low, i.e. in low- to mid-income countries.

## Environmental Risk Factors for Allergic Diseases

### AIR POLLUTION

There is considerable evidence showing that increased exposure to air pollutants is a risk factor for increased morbidity of asthma with worsening of symptoms and lung function.<sup>43</sup> Air pollution is a complex mixture of particulate matter of variable size and various gases. As particulates and polluting gases often co-occur, their individual contribution to worsening of asthma is hard to disentangle. In panel and time-series studies, air pollutants such as fine particles and ozone reduce lung function in children already affected by asthma and increase symptoms and medication use. Likewise, emergency room visits, general practitioner activities and hospital admissions for asthma and wheeze are positively associated with ambient air pollution levels.

Mixes of particulate matter, especially those seen with traffic related exposures, seem to have the most adverse effects. Traffic related air pollution is a complex mix of particulate matter and primary gaseous emissions including nitrogen oxides, which lead to the generation of secondary pollutants such as ozone, nitrates and organic aerosol. Traffic related pollution decreases quickly with distance from roadways. For adverse effects, distance within 300–500 m of roadways seems to be most significant. In large North American cities, 30–45% of people live within this distance and so the impact of traffic related air pollution is significant. The closeness to major roadways may be even greater in cities in Europe and the developing world. Given that disadvantaged families live close to major roadways, other risk factors such as poverty, stress and cigarette smoking may aggravate the effects.<sup>44</sup>

The role of air pollution in the new onset of asthma and allergic sensitization is less well understood.<sup>43</sup> There is however a growing body of prospective studies suggesting a causal role for the incidence of asthma among children and adults. In particular, long-term exposure to traffic related air pollution may again play a significant role.

### ENVIRONMENTAL TOBACCO SMOKE

Numerous surveys have consistently reported an association between environmental tobacco smoke (ETS) exposure and respiratory diseases. Strong evidence exists that passive smoking increases the risk of lower respiratory tract illnesses such as bronchitis, wheezy bronchitis and pneumonia in infants and young children. Maternal smoking during pregnancy and early childhood has been shown to be strongly associated with impaired lung growth and diminished lung function,<sup>2,3</sup> which in turn may predispose infants to develop transient early wheezing. In children with asthma, parental smoking increases symptoms and the frequency of asthma attacks. Banning tobacco smoke in public places has been shown in a number of countries to result in a significant reduction in hospital admissions for asthma.<sup>45</sup>

A series of epidemiological studies has also been performed to determine the effect of ETS exposure on the new onset of asthma. In most cross-sectional and longitudinal studies, passive and more importantly active smoking appears to be an important risk factor for the development of childhood, adolescent and adult asthma. In turn, no unequivocal association between ETS exposure, atopic sensitization and atopic dermatitis was found.

### WATER HARDNESS AND DAMPNESS

The domestic water supply may be relevant for the inception of atopic dermatitis. An ecological study of the relation between domestic water hardness and the prevalence of atopic eczema among British school children was performed.<sup>46</sup> Geographical information systems were used to link the geographical distribution of eczema in the study area to four categories of domestic water-hardness data. Among school children aged 4 to 16 years, a significant relation was found between the prevalence of atopic eczema and water hardness, both before and after adjustment for potential confounding factors. The effect on recent eczema symptoms was stronger than on lifetime prevalence, which may indicate that water hardness acts more on existing dermatitis by exacerbating the disorder or prolonging its duration rather than as a cause of new cases. These observations await replication by other studies.

In 2004 a report by the Institutes of Medicine Committee on Damp Indoor Spaces and Health in the USA concluded that there is sufficient evidence of an association between exposure to a damp indoor environment and worsening of asthma symptoms, and that there is suggestive evidence of an association between exposure to a damp indoor environment and the development of asthma in children and adults. Dampness can elicit a number of different exposures such as fungi, bacteria or their constituents and emissions, or other agents related to damp indoor environments such as house dust mites and cockroaches. The responsible factors are not known but may vary among individuals or be potentiated in complex mixtures.<sup>47</sup>

### NUTRITION

Breastfeeding has long been recommended for the prevention of allergic diseases. The epidemiological evidence is, however, highly controversial.<sup>48</sup> Some studies even suggest that breastfeeding may result in risk of asthma and atopy, but these studies may reflect adherence to recommendations. Likewise, the age at introduction of solid foods has been fiercely debated and no



conclusive evidence has been reached that would allow general recommendations. Recently, the diversity of solid foods introduced in the first year of life has been linked to less atopic dermatitis and asthma later in life.<sup>49</sup>

There is increasing evidence relating body mass index to the prevalence and incidence of asthma in children and adults, males, and, more consistently, in adolescent females.<sup>50</sup> It is unlikely that the association is attributable to reverse causation, i.e. that asthma precedes obesity because of exercise-induced symptoms. Rather, weight gain can antedate the development of asthma. Weight reduction among asthmatic patients can result in improvements in lung function.<sup>50</sup> Obesity has been associated with inflammatory processes, which may contribute to asthma development. Other potential explanations are that mechanical factors promote asthma symptoms in obese individuals, or that gastroesophageal reflux as a result of obesity induces asthma. Furthermore, physical inactivity may promote both obesity and asthma.

Fruit, vegetable, cereal and starch consumption and intake of various fatty acids, vitamins A, C, D, E, minerals and antioxidants have all been studied.<sup>36</sup> However, diet is complex and difficult to measure, and standardized tools are still lacking. All methods pertaining to food frequency, individual food items, food patterns and serum nutrients can introduce substantial misclassification, and the close correlation of many nutrients presents problems when trying to identify independent effects. The evidence from prospective studies and randomized clinical trials for individual food items has been disappointing.<sup>51</sup> Thus, measures such as Mediterranean diet may better reflect real world exposures. A Mediterranean diet has in turn been linked to protection from asthma.<sup>52</sup>

## ALLERGEN EXPOSURE

Although in some studies a clear, almost linear dose-response relation between allergen exposure and sensitization has been found,<sup>53</sup> others describe a bell-shaped association with higher levels of exposures relating to lower rates of atopic sensitization.<sup>54</sup> Part of the discrepancy may relate to the type of allergen, since mostly cat but not house dust mite allergen exposure has been shown, in some studies, to exert protective effects at higher levels of exposure. Furthermore, there is some evidence that the presence of a dog or a cat, or both, protects from the development of allergic sensitization, indicating that the presence of an animal is more important than just exposure to its allergens.

The relationship between allergens, particularly house dust mite exposure, and asthma has been studied for many years. Overall, there is little evidence to suggest a positive association between house dust mite exposure and the new onset of childhood asthma.<sup>55</sup> Intervention studies have failed to show convincing evidence of a reduction in asthma risk after the implementation of avoidance strategies.<sup>56</sup> Other co-factors of exposure should, however, also be taken into account, such as exposure to microbial compounds. For example, levels of endotoxin and other microbial exposures have been shown to modify the effect of allergen exposure<sup>57–59</sup>

## FAMILY SIZE, INFECTIONS AND HYGIENE

Strachan first reported that sibship size, the number of children produced by a pair of parents, is inversely related to the prevalence of childhood atopic diseases and thereby proposed the 'hygiene hypothesis'.<sup>60</sup> This observation has since been

confirmed by numerous studies, all showing that atopy, hay fever and atopic eczema were inversely related to increasing numbers of siblings. In contrast, the relation between family size and childhood asthma and airway hyperresponsiveness is less clear. However, the underlying causes of this consistent protective effect remain unknown.

Viral infections of the respiratory tract are the major precipitants of acute exacerbations of wheezing illness at any age, yet viral respiratory infections are very common during infancy and early childhood and most children do not suffer any aftermath relating to these infections, including infections with respiratory syncytial virus and rhinovirus.<sup>61</sup> Thus, host factors in children susceptible to the development of wheezing illnesses and asthma are likely to play a major role. Deficiencies in innate immune responses have been shown to contribute to a subject's susceptibility to rhinovirus infections, the most prevalent cause of lower respiratory tract viral infections in infants associated with asthma development.<sup>62</sup> Interactions between viral lower respiratory tract infections and early atopic sensitization may play a role: only among children with early onset of atopy may repeated viral infections become a risk factor for developing asthma.<sup>63</sup>

However, an inverse relation between asthma and the overall burden of respiratory infections may also exist. Several studies investigating children in daycare have rather consistently shown that exposure to a daycare environment in the first months of life is associated with a significantly reduced risk of wheezing, hay fever and atopic sensitization at school age and adolescence.<sup>64,65</sup> It remains, however, unclear whether the burden of infections or other exposures in daycare early in life account for this protective effect. Several reports have shown that children who are sero-positive for hepatitis A, *Toxoplasma gondii* or *Helicobacter pylori* have a significantly lower prevalence of atopic sensitization, allergic rhinitis and allergic asthma as compared to their sero-negative peers.<sup>66</sup>

The use of antibiotics has been proposed as a risk factor for asthma and allergic diseases. In most cross-sectional studies a positive relation between antibiotics and asthma has been found which is, however, most likely to be attributable to reverse causation. Early in life, when it is difficult to diagnose asthma, antibiotics are often prescribed for respiratory symptoms in wheezy children and thus are positively associated with asthma later in life. Most studies using a prospective design have, however, failed to identify antibiotics as a risk factor antedating the new onset of asthma.<sup>67</sup> Similar problems arise when interpreting the positive relation between paracetamol use and asthma seen in cross-sectional studies.<sup>68</sup> Intervention trials are needed to come to firm conclusions.

Active and chronic helminthic infections were reported to be protective from atopy, but findings are less consistent for wheeze and asthma.<sup>69</sup> Part of the discrepancies in the literature reporting associations between helminths and allergic diseases may be the load of parasitic infestation and the type of helminths in a particular area. Microbial stimulation, both from normal commensals and pathogens through the gut, may be another route of exposure which may have altered the normal intestinal colonization pattern in infancy. Thereby, the induction and maintenance of oral tolerance of innocuous antigens such as food proteins and inhaled allergens may be substantially hampered. These hypotheses, though intriguing, have to date not been supported by epidemiological evidence since significant methodological difficulties arise when attempting to measure the microbial pattern of the intestinal flora.

Exposure to microbes does not only occur through invasive infection of human tissues. Viable germs and nonviable parts of microbial organisms are ubiquitous in nature and can be found in varying concentrations in our daily indoor and outdoor environments, and also in urban areas. These microbial products are recognized by the innate immune system and induce an inflammatory response. Therefore, environmental exposure to microbial products may play a crucial role in the maturation of a child's immune response, enabling tolerance of other components of its natural environment such as pollen and animal dander.

A number of studies have in fact shown that environmental exposure to endotoxin, a component of the cell wall of Gram negative bacteria, is inversely related to the development of atopic sensitization and atopic dermatitis<sup>70</sup>; yet endotoxin exposure is a risk factor for wheezing and asthma as shown in a number of studies.<sup>71</sup> Muramic acid, a component of the cell wall of all bacteria, but more abundant in Gram positive bacteria, has been inversely related to asthma and wheeze, but not atopy.<sup>72</sup> Compounds related to fungal exposures, such as extracellular polysaccharides derived from *Penicillium* spp. and *Aspergillus* spp., have also been inversely associated with asthma.<sup>73</sup> These microbial compounds are found in higher abundance in farming than nonfarming environments. Recent findings using culture based and DNA based analyses suggest that the diversity in environmental microbial (bacterial and fungal) exposures explains at least in part the 'farm effect' on childhood asthma.<sup>31</sup>

These environmental microbial exposures may shape a subject's microbiome at mucosal surfaces. Thus, the true intermediary between the environment and the host may be the microbiota. While there exists intriguing evidence in experimental studies in mice, the precise role of the microbiome for developing allergic diseases on a population level has not been determined.

## Gene-Environment Interactions

The genetics of asthma will be discussed in Chapter 3 and are touched on here only in the context of environmental exposures. In general, the identification of novel genes for asthma

suggests that many genes with small effects, rather than a few genes with strong effects, contribute to the development of asthma and atopy.<sup>74</sup> These genetic effects may, in part, differ with respect to a subject's environmental exposures, although some genes may also exert their effect independently of the environment.

A number of gene-environment interactions have been found, which are discussed in detail by von Mutius<sup>74</sup> and Le Souef.<sup>75</sup> These interactions confer additional biologic plausibility for the identified environmental exposures in the inception of asthma and allergic diseases. For example, the interaction of polymorphisms in the *TLR2* gene with a farming environment or daycare settings is highly suggestive of microbial exposures underlying this observation. Conversely, the more detrimental effects of passive smoking in people with genetically determined insufficient detoxification (e.g. GST Null genotypes) highlight the importance of taking a host's susceptibility into account when estimating the effect size of harmful exposures.<sup>76</sup> Thereby, the analysis of gene-environment interactions may result in the identification of individuals who are particularly vulnerable to certain environmental exposures.

## Conclusions

Large variations in the prevalence of childhood and adult asthma and allergies have been reported. In affluent, urbanized centers, prevalences are generally higher than in poorer centers with the exception of the inner city environments in the USA, where prevalences are particularly high. Lower levels are seen, especially in some rural areas in Africa and Asia and among farmers' children in Europe. Numerous environmental factors have been scrutinized, but no conclusive explanation for the rising trends has been found. Future challenges are to tackle the complex interplay between environmental factors and genetic determinants.

The complete reference list can be found on the companion Expert Consult website at <http://www.expertconsult.inking.com>.

## KEY REFERENCES

- Worldwide variation in prevalence of symptoms of asthma, allergic rhinoconjunctivitis, and atopic eczema: ISAAC. The International Study of Asthma and Allergies in Childhood (ISAAC) Steering Committee. *Lancet* 1998; 351:1225–32.
- von Mutius E, Weiland SK, Fritsch C, Duhme H, Keil U. Increasing prevalence of hay fever and atopy among children in Leipzig, East Germany. *Lancet* 1998;351:862–6.
- von Mutius E, Radon K. Living on a farm: impact on asthma induction and clinical course. *Immunol Allergy Clin North Am* 2008; 28:631–47, ix–x.
- Eder W, Ege MJ, von Mutius E. The asthma epidemic. *N Engl J Med* 2006;355:2226–35.
- Asher MI, Montefort S, Bjorksten B, Lai CK, Strachan DP, Weiland SK, et al. Worldwide time trends in the prevalence of symptoms of asthma, allergic rhinoconjunctivitis, and eczema in childhood: ISAAC Phases One and Three repeat multicountry cross-sectional surveys. *Lancet* 2006;368:733–43.
- Guarnieri M, Balmes JR. Outdoor air pollution and asthma. *Lancet* 2014;383:1581–92.
- Mackay D, Haw S, Ayres JG, Fischbacher C, Pell JP. Smoke-free legislation and hospitalizations for childhood asthma. *N Engl J Med* 2010; 363:1139–45.
- Institute of Medicine. *Damp indoor spaces and health*. Washington (DC), 2004.
- Simpson A, Custovic A. Allergen avoidance in the primary prevention of asthma. *Curr Opin Allergy Clin Immunol* 2004;4:45–51.
- Johnston SL. Overview of virus-induced airway disease. *Proc Am Thorac Soc* 2005; 2:150–6.

## REFERENCES

- Morgan WJ, Stern DA, Sherrill DL, Guerra S, Holberg CJ, Guilbert TW, et al. Outcome of asthma and wheezing in the first 6 years of life: follow-up through adolescence. *Am J Respir Crit Care Med* 2005;172:1253–8.
- Dezateux C, Stocks J, Dundas I, Fletcher ME. Impaired airway function and wheezing in infancy: the influence of maternal smoking and a genetic predisposition to asthma. *Am J Respir Crit Care Med* 1999;159:403–10.
- Tager IB, Ngo L, Hanrahan JP. Maternal smoking during pregnancy. Effects on lung function during the first 18 months of life. *Am J Respir Crit Care Med* 1995;152:977–83.
- Rauh VA, Chew GR, Garfinkel RS. Deteriorated housing contributes to high cockroach allergen levels in inner-city households. *Environ Health Perspect* 2002;110(Suppl. 2):323–7.
- Illi S, von Mutius E, Lau S, Niggemann B, Gruber C, Wahn U, et al. Perennial allergen sensitisation early in life and chronic asthma in children: a birth cohort study. *Lancet* 2006;368:763–70.
- von Mutius E. Paediatric origins of adult lung disease. *Thorax* 2001;56:153–7.
- Depner M, Fuchs O, Genuneit J, Karvonen AM, Hyvarinen A, Kaulek V, et al. Clinical and epidemiologic phenotypes of childhood asthma. *Am J Respir Crit Care Med* 2014;189:129–38.
- von Mutius E. Risk factors for atopic dermatitis. In: Bieber T, Leung DYM, editors. *Atopic dermatitis*. New York, Basel: Marcel Dekker; 2002. p. 111–22.
- Worldwide variation in prevalence of symptoms of asthma, allergic rhinoconjunctivitis, and atopic eczema: ISAAC. The International Study of Asthma and Allergies in Childhood (ISAAC) Steering Committee. *Lancet* 1998;351:1225–32.
- Burney PG, Luczynska C, Chinn S, Jarvis D. The European Community Respiratory Health Survey. *Eur Respir J* 1994;7:954–60.
- Janson C, Anto J, Burney P, Chinn S, de Marco R, Heinrich J, et al. The European Community Respiratory Health Survey: what are the main results so far? *European Community Respiratory Health Survey II*. *Eur Respir J* 2001;18:598–611.
- Pearce N, Sunyer J, Cheng S, Chinn S, Bjorksten B, Burr M, et al. Comparison of asthma prevalence in the ISAAC and the ECRHS. ISAAC Steering Committee and the European Community Respiratory Health Survey. *International Study of Asthma and Allergies in Childhood*. *Eur Respir J* 2000;16:420–6.
- Pearce N, Pekkanen J, Beasley R. How much asthma is really attributable to atopy? *Thorax* 1999;54:268–72.
- Scrivener S, Yemaneberhan H, Zebeignis M, Tilahun D, Girma S, Ali S, et al. Independent effects of intestinal parasite infection and domestic allergen exposure on risk of wheeze in Ethiopia: a nested case-control study. *Lancet* 2001;358:1493–9.
- Weinmayr G, Weiland SK, Bjorksten B, Brunekreef B, Buchele G, Cookson WO, et al. Atopic sensitization and the international variation of asthma symptom prevalence in children. *Am J Respir Crit Care Med* 2007;176:565–74.
- von Mutius E, Martinez FD, Fritzsche C, Nicolai T, Roell G, Thiemann HH. Prevalence of asthma and atopy in two areas of West and East Germany. *Am J Respir Crit Care Med* 1994;149(2 Pt 1):358–64.
- Bjorksten B, Dumitrascu D, Foucard T, Khet-suriani N, Khaitov R, Leja M, et al. Prevalence of childhood asthma, rhinitis and eczema in Scandinavia and Eastern Europe. *Eur Respir J* 1998;12:432–7.
- Braback L, Breborowicz A, Julge K, Knutsson A, Riikjarv MA, Vasar M, et al. Risk factors for respiratory symptoms and atopic sensitisation in the Baltic area. *Arch Dis Child* 1995;72:487–93.
- Nowak D, Heinrich J, Jorres R, Wassmer G, Berger J, Beck E, et al. Prevalence of respiratory symptoms, bronchial hyperresponsiveness and atopy among adults: west and east Germany. *Eur Respir J* 1996;9:2541–52.
- Schafer T, Ring J. Epidemiology of allergic diseases. *Allergy* 1997;52(38 Suppl.):14–22, discussion 35–6.
- von Mutius E, Weiland SK, Fritzsche C, Duhme H, Keil U. Increasing prevalence of hay fever and atopy among children in Leipzig, East Germany. *Lancet* 1998;351:862–6.
- Sozanska B, Blaszczyk M, Pearce N, Cullinan P. Atopy and allergic respiratory disease in rural Poland before and after accession to the European Union. *J Allergy Clin Immunol* 2014;133:1347–53.
- Wong GW, Hui DS, Chan HH, Fok TF, Leung R, Zhong NS, et al. Prevalence of respiratory and atopic disorders in Chinese schoolchildren. *Clin Exp Allergy* 2001;31:1225–31.
- Viinainen A, Munhbayarlah S, Zevgee T, Narantsetseg L, Naidansuren T, Koskenvuo M, et al. The protective effect of rural living against atopy in Mongolia. *Allergy* 2007;62:272–80.
- von Mutius E, Radon K. Living on a farm: impact on asthma induction and clinical course. *Immunol Allergy Clin North Am* 2008;28:631–47, ix–x.
- von Mutius E, Vercelli D. Farm living: effects on childhood asthma and allergy. *Nat Rev Immunol* 2010;10:861–8.
- Leynaert B, Guillaud-Bataille M, Soussan D, Benessiano J, Guenegou A, Pin I, et al. Association between farm exposure and atopy, according to the CD14 C-159T polymorphism. *J Allergy Clin Immunol* 2006;118:658–65.
- Portengen L, Sigsgaard T, Omland O, Hjort C, Heederik D, Doekes G. Low prevalence of atopy in young Danish farmers and farming students born and raised on a farm. *Clin Exp Allergy* 2002;32:247–53.
- Smit LA, Zuurbier M, Doekes G, Wouters IM, Heederik D, Douwes J. Hay fever and asthma symptoms in conventional and organic farmers in The Netherlands. *Occup Environ Med* 2007;64:101–7.
- Riedler J, Braun-Fahrlander C, Eder W, Schreuer M, Waser M, Maisch S, et al. Exposure to farming in early life and development of asthma and allergy: a cross-sectional survey. *Lancet* 2001;358:1129–33.
- Ege MJ, Mayer M, Normand AC, Genuneit J, Cookson WO, Braun-Fahrlander C, et al. Exposure to environmental microorganisms and childhood asthma. *N Engl J Med* 2011;364:701–9.
- Webber MP, Carpinello KE, Oruwayiye T, Appel DK. Prevalence of asthma and asthma-like symptoms in inner-city elementary schoolchildren. *Pediatr Pulmonol* 2002;34:105–11.
- Bauman LJ, Wright E, Leickly FE, Crain E, Kruszon-Moran D, Wade SL, et al. Relationship of adherence to pediatric asthma morbidity among inner-city children. *Pediatrics* 2002;110(1 Pt 1):e6.
- Alp H, Yu BH, Grant EN, Rao V, Moy JN. Cockroach allergy appears early in life in inner-city children with recurrent wheezing. *Ann Allergy Asthma Immunol* 2001;86:51–4.
- Litonjua AA, Carey VJ, Burge HA, Weiss ST, Gold DR. Exposure to cockroach allergen in the home is associated with incident doctor-diagnosed asthma and recurrent wheezing. *J Allergy Clin Immunol* 2001;107:41–7.
- Eder W, Ege MJ, von Mutius E. The asthma epidemic. *N Engl J Med* 2006;355:2226–35.
- Vollmer WM, Osborne ML, Buist AS. 20-year trends in the prevalence of asthma and chronic airflow obstruction in an HMO. *Am J Respir Crit Care Med* 1998;157(4 Pt 1):1079–84.
- Eggleston PA, Buckley TJ, Breyse PN, Wills-Karp M, Kleeberger SR, Jaakkola JJ. The environment and asthma in U.S. inner cities. *Environ Health Perspect* 1999;107(Suppl. 3):439–50.
- Ronchetti R, Villa MP, Barreto M, Rota R, Paganì J, Martella S, et al. Is the increase in childhood asthma coming to an end? Findings from three surveys of schoolchildren in Rome, Italy. *Eur Respir J* 2001;17:881–6.
- Zollner IK, Weiland SK, Piechotowski I, Gabrio T, von Mutius E, Link B, et al. No increase in the prevalence of asthma, allergies, and atopic sensitisation among children in Germany: 1992–2001. *Thorax* 2005;60:545–8.
- Grize L, Gassner M, Wuthrich B, Bringolf-Isler B, Takken-Sahli K, Sennhauser FH, et al. Trends in prevalence of asthma, allergic rhinitis and atopic dermatitis in 5–7-year old Swiss children from 1992 to 2001. *Allergy* 2006;61:556–62.
- Asher MI, Montefort S, Bjorksten B, Lai CK, Strachan DP, Weiland SK, et al. Worldwide time trends in the prevalence of symptoms of asthma, allergic rhinoconjunctivitis, and eczema in childhood: ISAAC Phases One and Three repeat multicountry cross-sectional surveys. *Lancet* 2006;368:733–43.
- Guarnieri M, Balmes JR. Outdoor air pollution and asthma. *Lancet* 2014;383:1581–92.
- Nicolai T, Carr D, Weiland SK, Duhme H, von Ehrenstein O, Wagner C, et al. Urban traffic and pollutant exposure related to respiratory outcomes and atopy in a large sample of children. *Eur Respir J* 2003;21:956–63.
- Mackay D, Haw S, Ayres JG, Fischbacher C, Pell JP. Smoke-free legislation and hospitalizations for childhood asthma. *N Engl J Med* 2010;363:1139–45.
- McNally NJ, Williams HC, Phillips DR, Smallman-Raynor M, Lewis S, Venn A, et al. Atopic eczema and domestic water hardness. *Lancet* 1998;352:527–31.
- Institute of Medicine. *Damp indoor spaces and health*. Washington (DC), 2004.
- Dogaru CM, Nyffenegger D, Pescatore AM, Spycher BD, Kuehni CE. Breastfeeding and childhood asthma: systematic review and meta-analysis. *Am J Epidemiol* 2014;179:1153–67.
- Roduit C, Frei R, Depner M, Schaub B, Loss G, Genuneit J, et al. Increased food diversity in

- the first year of life is inversely associated with allergic diseases. *J Allergy Clin Immunol* 2014;133:1056–64.
50. Schaub B, von Mutius E. Obesity and asthma, what are the links? *Curr Opin Allergy Clin Immunol* 2005;5:185–93.
  51. McKeever TM, Britton J. Diet and asthma. *Am J Respir Crit Care Med* 2004;170:725–9.
  52. Lv N, Xiao L, Ma J. Dietary pattern and asthma: a systematic review and meta-analysis. *J Asthma Allergy* 2014;7:105–21.
  53. Lau S, Nickel R, Niggemann B, Gruber C, Sommerfeld C, Illi S, et al. The development of childhood asthma: lessons from the German Multicentre Allergy Study (MAS). *Paediatr Respir Rev* 2002;3:265–72.
  54. Platts-Mills T, Vaughan J, Squillace S, Woodfolk J, Sporik R. Sensitisation, asthma, and a modified Th2 response in children exposed to cat allergen: a population-based cross-sectional study. *Lancet* 2001;357:752–6.
  55. Lau S, Illi S, Sommerfeld C, Niggemann B, Bergmann R, von Mutius E, et al. Early exposure to house-dust mite and cat allergens and development of childhood asthma: a cohort study. Multicentre Allergy Study Group. *Lancet* 2000;356:1392–7.
  56. Simpson A, Custovic A. Allergen avoidance in the primary prevention of asthma. *Curr Opin Allergy Clin Immunol* 2004;4:45–51.
  57. Litonjua AA, Milton DK, Celedon JC, Ryan L, Weiss ST, Gold DR. A longitudinal analysis of wheezing in young children: the independent effects of early life exposure to house dust endotoxin, allergens, and pets. *J Allergy Clin Immunol* 2002;110:736–42.
  58. Demehri S, Yockey LJ, Visness CM, Jaffee KF, Turkoz A, Wood RA, et al. Circulating TSLP associates with decreased wheezing in non-atopic preschool children: data from the URECA birth cohort. *Clin Exp Allergy* 2014;44:851–7.
  59. Lynch SV, Wood RA, Boushey H, Bacharier LB, Bloomberg GR, Kattan M, et al. Effects of early-life exposure to allergens and bacteria on recurrent wheeze and atopy in urban children. *J Allergy Clin Immunol* 2014;134:593–601 e12.
  60. Strachan DP. Hay fever, hygiene, and household size. *BMJ* 1989;299:1259–60.
  61. Long CE, McBride JT, Hall CB. Sequelae of respiratory syncytial virus infections. A role for intervention studies. *Am J Respir Crit Care Med* 1995;151:1678–80, discussion 80–1.
  62. Johnston SL. Overview of virus-induced airway disease. *Proc Am Thorac Soc* 2005;2:150–6.
  63. Kusel MM, de Klerk NH, Kebadze T, Vohma V, Holt PG, Johnston SL, et al. Early-life respiratory viral infections, atopic sensitization, and risk of subsequent development of persistent asthma. *J Allergy Clin Immunol* 2007;119:1105–10.
  64. Ball TM, Castro-Rodriguez JA, Griffith KA, Holberg CJ, Martinez FD, Wright AL. Siblings, day-care attendance, and the risk of asthma and wheezing during childhood. *N Engl J Med* 2000;343:538–43.
  65. Celedon JC, Wright RJ, Litonjua AA, Sredl D, Ryan L, Weiss ST, et al. Day care attendance in early life, maternal history of asthma, and asthma at the age of 6 years. *Am J Respir Crit Care Med* 2003;167:1239–43.
  66. Matricardi PM. The role of early infections, hygiene and intestinal microflora. *Pediatr Pulmonol Suppl* 2004;26:211–12.
  67. Bremner SA, Carey IM, DeWilde S, Richards N, Maier WC, Hilton SR, et al. Early-life exposure to antibacterials and the subsequent development of hayfever in childhood in the UK: case-control studies using the General Practice Research Database and the Doctors' Independent Network. *Clin Exp Allergy* 2003;33:1518–25.
  68. Beasley R, Clayton T, Crane J, von Mutius E, Lai CK, Montefort S, et al. Association between paracetamol use in infancy and childhood, and risk of asthma, rhinoconjunctivitis, and eczema in children aged 6–7 years: analysis from Phase Three of the ISAAC programme. *Lancet* 2008;372:1039–48.
  69. Yazdanbakhsh M, Matricardi PM. Parasites and the hygiene hypothesis: regulating the immune system? *Clin Rev Allergy Immunol* 2004;26:15–24.
  70. Gehring U, Bolte G, Borte M, Bischof W, Fahlbusch B, Wichmann HE, et al. Exposure to endotoxin decreases the risk of atopic eczema in infancy: a cohort study. *J Allergy Clin Immunol* 2001;108:847–54.
  71. Braun-Fahrlander C, Riedler J, Herz U, Eder W, Waser M, Grize L, et al. Environmental exposure to endotoxin and its relation to asthma in school-age children. *N Engl J Med* 2002;347:869–77.
  72. van Strien RT, Engel R, Holst O, Bufe A, Eder W, Waser M, et al. Microbial exposure of rural school children, as assessed by levels of N-acetyl-muramic acid in mattress dust, and its association with respiratory health. *J Allergy Clin Immunol* 2004;113:860–7.
  73. Ege MJ, Frei R, Bieli C, Schram-Bijkerk D, Waser M, Benz MR, et al. Not all farming environments protect against the development of asthma and wheeze in children. *J Allergy Clin Immunol* 2007;119:1140–7.
  74. von Mutius E. Gene-environment interactions in asthma. *J Allergy Clin Immunol* 2009;123:3–11, quiz 2–3.
  75. Le Souef PN. Gene-environment interaction in the development of atopic asthma: new developments. *Curr Opin Allergy Clin Immunol* 2009;9:123–7.
  76. Kabesch M, Hoefler C, Carr D, Leupold W, Weiland SK, von Mutius E. Glutathione S transferase deficiency and passive smoking increase childhood asthma. *Thorax* 2004;59:569–73.



# Natural History of Allergic Diseases and Asthma

ANDREW H. LIU | FERNANDO D. MARTINEZ

## KEY POINTS

- The atopic disorders – atopic dermatitis, food and inhalant allergies, allergic rhinoconjunctivitis and asthma – tend to cluster in individuals, families and locales
- A developmental ‘allergic march’ of childhood begins with atopic dermatitis, food allergies and bronchiolitis episodes in the first few years of life, and progresses to inhalant allergic sensitization, allergic rhinoconjunctivitis and atopic asthma.
- Although persistent asthma commonly begins in the first few years of life, most infants and toddlers who have recurrent bronchiolitis episodes do not go on to have persistent asthma in later childhood and adulthood. Early life predictive factors for disease persistence include allergic march manifestations (atopic dermatitis, food allergy, allergic sensitization to inhalant allergens), recurrent bronchiolitis episodes triggered by common rhinoviruses, and parental asthma.
- Epidemiologic evidence suggests that atopic disorders are caused by environmental and lifestyle factors in the susceptible host.
- While atopy is a common feature of childhood asthma, additional factors appear to contribute to severe, persistent disease expression, including early onset, chronic exposure to sensitized allergen in the home and a dys-regulated ‘Th2-high’ immunopathology.

Natural history studies of allergic diseases and asthma are fundamental for predicting disease onset and prognosis. Such studies reveal a developmental ‘allergic march’ in childhood, from the early onset of atopic dermatitis (AD) and food allergies in infancy, to asthma, allergic rhinitis (AR) and inhalant allergen sensitization in later childhood. Allergy and asthma of earlier onset and greater severity are generally associated with disease persistence. Therefore, allergy and asthma commonly develop during the early childhood years, the period of greatest immune maturation and lung growth. This highlights the importance of growth and development in a conceptual framework for allergy and asthma pathogenesis.

This chapter reviews the allergic march of childhood and its different clinical manifestations: food allergies, AD, inhalant allergies, AR and asthma. The natural history of anaphylaxis, an allergic condition not currently implicated in the allergic march, is also covered. Interventions that reduce the prevalence of allergy and asthma are reviewed toward the end of the chapter. The findings and conclusions presented in this chapter are largely based on long-term prospective (i.e. ‘natural history’)

studies. Complementary reviews of the epidemiology of allergic diseases in childhood can be found in Chapter 1, and the prevention and natural history of food allergy in Chapter 43.

## Allergic March of Childhood

Three prospective, longitudinal, birth cohort studies exemplify optimized natural history studies that are rich resources for our current understanding of the development and outcome of allergy and asthma in childhood: (1) the Tucson Children’s Respiratory Study (CRS) in Tucson, Arizona (begun in 1980); (2) a Kaiser-based study in San Diego, California (begun in 1981); and the German Multicentre Allergy Study (MAS) in Germany (begun in 1990). The major findings of these studies have been consistent and reveal a common pattern of allergy and asthma development that begins in infancy.

1. The highest incidence of AD and food allergies is in the first 2 years of life (Figure 2-1). It is generally believed that infants rarely manifest allergic symptoms in the first month of life. By 3 months of age, however, AD, food allergies and wheezing problems are common.
2. This is paralleled by a high prevalence of food allergen sensitization in the first 2 years of life.<sup>1</sup> Early food allergen sensitization is an important risk factor for food allergies, AD and asthma.
3. Allergic airways diseases generally begin slightly later in childhood (see Figure 2-1). Childhood asthma often initially manifests with a lower respiratory tract infection or bronchiolitis episodes in the first few years of life.
4. AR commonly begins in childhood, although there is also good evidence that it often develops in early adulthood.<sup>2,3</sup>
5. The development of AR and persistent asthma is paralleled by a rise in inhalant allergen sensitization. Perennial inhalant allergen sensitization (i.e. cat dander, dust mites) emerges between 2 and 5 years of age, and seasonal inhalant allergen sensitization becomes apparent slightly later in life (ages 3 to 5 years).

## Early Immune Development Underlying Allergies

A paradigm of immune development underlies allergy development and progression in early childhood (see Chapter 6). Briefly, the immune system of the fetus is maintained in a tolerogenic state, preventing adverse immune responses and rejection between the mother and fetus. Placental interleukin-10 (IL-10) suppresses the production of immune-potentiating interferon gamma (IFN- $\gamma$ ) by fetal immune cells. IFN- $\gamma$  down-regulates the production of pro-allergic cytokines, such as IL-4

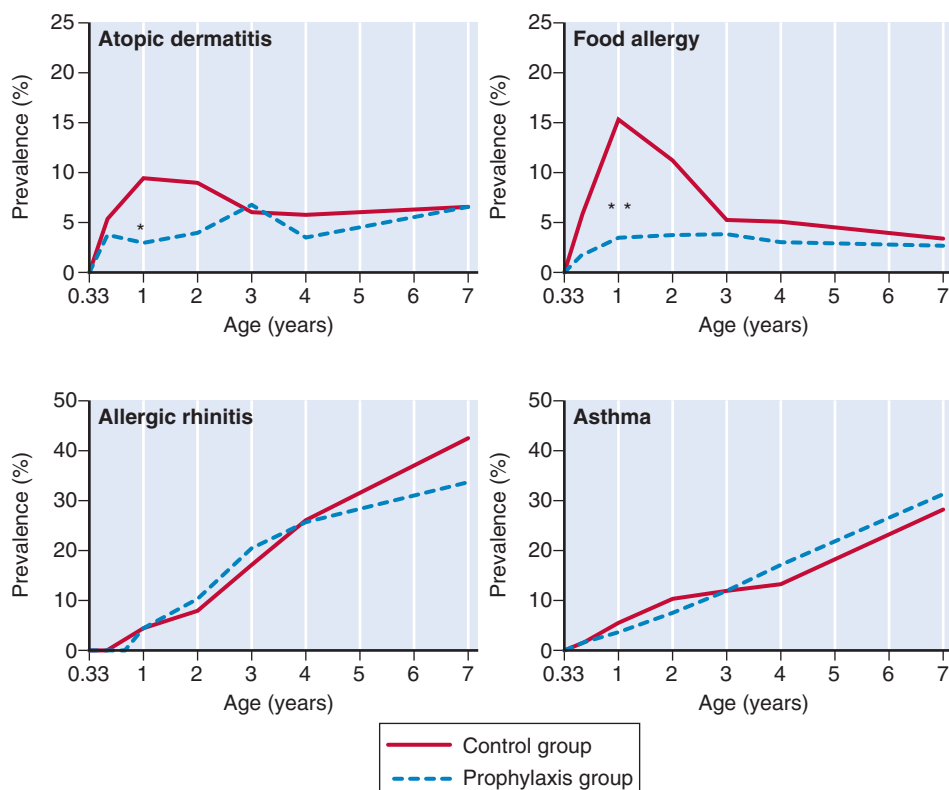

**Figure 2-1** Allergic march of early childhood. Period prevalence of atopic dermatitis, food allergy, allergic rhinitis and asthma from birth to 7 years in prophylactic-treated (allergenic food avoidance) and untreated (control) groups (Kaiser Permanente; San Diego). \* $P \leq .05$ ; \*\* $P < .01$ . (Data from Zeiger RS, Heller S, *J Allergy Clin Immunol* 1995;95:1179–90; and Zeiger RS, Heller S, Mellon MH, et al. *J Allergy Clin Immunol* 1989;84:72–89.)

and IL-13. The reciprocal relationship between these cytokines and the immune cells that produce them defines ‘T-helper 2’ (Th2), pro-allergic immune responses (i.e. IL-4, IL-13), and anti-allergic ‘T-helper 1’ (Th1) immune development (i.e. IFN- $\gamma$ ). Thus the conditions that favor immune tolerance in utero may also foster allergic immune responses, such that newborn immune responses to ubiquitous ingested and inhaled proteins are Th2 biased.<sup>4</sup> Postnatally, encounters with these common allergenic proteins lead to the development of mature immune responses to them. The underlying immune characteristics of allergic diseases – allergen-specific memory Th2 cells and immunoglobulin E (IgE) – can be viewed as aberrant manifestations of immune maturation that typically develop during these early years, and might have their roots in the inadequate or delayed development of regulatory T lymphocytes that can inhibit them.

### TOTAL SERUM IgE LEVELS

At birth, cord blood IgE levels are almost undetectable; these levels increase during the first 6 years of life. Elevated serum IgE levels in infancy have been associated with persistent asthma in later childhood.<sup>5</sup> High serum IgE levels in later childhood (i.e. after 11 years of age) have also been well correlated with bronchial hyperresponsiveness (BHR) and asthma.<sup>6,7</sup>

### ALLERGEN-SPECIFIC IgE

In two birth cohort (up to 5 years old) studies of IgG and IgE antibody development to common food and inhalant allergens,

IgG antibodies to milk and egg proteins were detectable in nearly all subjects in the first 12 months of life, implying that the infant immune system sees and responds to commonly ingested proteins.<sup>8,9</sup> In comparison, food allergen-specific IgE (especially to egg) was measurable in approximately 30% of subjects at 1 year of age. Low-level IgE responses to food allergens in infancy were common and transient, and sometimes occurred before introduction of the foods into the diet. In children who developed clinical allergic conditions, higher levels and persistence of food allergen-specific IgE were typical.

Of seasonal inhalant allergens, ragweed and grass allergen-specific IgGs were detectable in approximately 25% of subjects at 3 to 6 months of age, and steadily increased to 40% to 50% by 5 years of age.<sup>10,11</sup> In comparison, allergen-specific IgE was detected in <5% of subjects from 3 to 12 months of age, and increased in prevalence to approximately 20% by 5 years of age. Therefore, allergen-specific IgE production emerges in the preschool years and persists in those who develop clinical allergies.

### ALLERGEN-SPECIFIC TH2 LYMPHOCYTES, AND THEIR REGULATION BY TH1 AND TREG LYMPHOCYTES

The development of allergen-specific antibody production is indicative of allergen-specific T lymphocytes that are guiding the development and differentiation of B lymphocytes to produce IgE through secreted Th2-type cytokines (i.e. IL-4, IL-13) and cell surface molecular interactions (i.e. CD40/CD40

ligand). T cell-derived IL-4, IL-5 and GM-CSF also support eosinophil and mast cell development and differentiation in allergic inflammation. A current paradigm for allergic disease suggests that pro-allergic Th2 cells are (1) differentiated to produce cytokines that direct allergic responses and inflammation, (2) opposed by Th1 cells that produce counter-regulatory cytokines (e.g. IFN- $\gamma$ ) that inhibit Th2 differentiation, and (3) suppressed by regulatory T lymphocytes. As an example of this Th2/Th1/TREG paradigm, peripheral blood mononuclear cells from infants who have milk allergy or peanut sensitization, or ultimately manifest allergic disease at 2 years of age, produce more pro-allergic Th2 cytokines (i.e. IL-4) to allergen-specific stimulation *in vitro*.<sup>10,12</sup> In comparison, infants who continue to be nonallergic (i.e. no allergic disease and/or no allergen sensitization in later childhood) produce more counter-regulatory IFN- $\gamma$  to nonspecific<sup>5,11</sup> and allergen-specific<sup>10</sup> stimuli. Infants with reduced allergic sensitization also have increased IL-10-producing T lymphocyte numbers and suppressive function.<sup>13</sup>

Infants with diminished Th1 responses may be more susceptible to developing asthma for additional reasons. Bronchiolitic infants who continue to have persistent wheezing and airflow obstruction also produce less IFN- $\gamma$ .<sup>14</sup> This suggests that infants who produce less IFN- $\gamma$  to ubiquitous allergens and to airway viral infections are susceptible to chronic allergic diseases and asthma because (1) they are less able to impede the development of allergen-specific T cells and IgE, and (2) they are more likely to manifest persistent airways abnormalities following respiratory viral infections.

## Childhood Asthma

Approximately 80% of asthmatic patients report disease onset before 6 years of age.<sup>15</sup> However, of all young children who experience recurrent wheezing, only a minority will go on to have persistent asthma in later life. The most common form of recurrent wheezing in preschool children occurs primarily with viral infections (Box 2-1). These ‘transient wheezers’ or ‘wheezy bronchitics’ are not at an increased risk of having asthma in later life. Transient wheezing is associated with airways viral infections, smaller airways and lung size, male gender, low birth weight, and prenatal environmental tobacco smoke (ETS) exposure.

### BOX 2-1 KEY CONCEPTS

#### Childhood Wheezing and Asthma Phenotypes

- Transient early wheezing or wheezy bronchitis: most common in infancy and preschool years
- Persistent allergy-associated asthma: most common phenotype in school-age children, adults and elderly
- Nonallergic wheezing: associated with bronchial hyperresponsiveness at birth; continues into childhood
- Asthma associated with obesity, female gender and early-onset puberty: emerges between 6 and 11 years of age
- Asthma mediated by occupational-type exposures: a probable type of childhood asthma in children living in particular locales, although not yet demonstrated
- Triad asthma: asthma associated with chronic sinusitis, nasal polyposis and/or hypersensitivity to nonsteroidal anti-inflammatory medications (e.g. aspirin, ibuprofen); rarely begins in childhood

Persistent asthma commonly begins and co-exists with the large population of transient wheezers (see Box 2-1). Persistent asthma is strongly associated with allergy, which is evident in the early childhood years as clinical conditions (i.e. AD, AR, food allergies) or by testing for allergen sensitization to inhalant and food allergens (e.g. IgE, allergy skin testing). Severity of childhood asthma, determined clinically or by lung function impairment, also predicts asthma persistence into adulthood.

## Early Childhood: Transient vs Persistent Asthma

In the Tucson CRS study, approximately 50% of young children experienced a period of recurrent wheezing and/or coughing in the first 6 years of life.<sup>16</sup> These early-childhood wheezers were further subdivided into: (1) ‘transient early wheezers,’ with wheezing only <3 years; (2) ‘persistent wheezers,’ with manifestations through the first 6 years; and (3) ‘late-onset wheezers,’ with manifestations only after 3 years. Transient wheezers comprised the largest proportion of the group, at 20%; persistent and late-onset wheezers made up slightly smaller proportions (14% and 15%, respectively). Of the three groups, persistent wheezers had the greatest likelihood of persistent asthma in later childhood (Figure 2-2). By age 16 years, approximately 50% of those with persistent or late-onset wheezing in early life continued to have recurrent wheezing/coughing episodes.<sup>17</sup> In contrast, the prevalence of persistent asthma in the transient wheezer group was approximately 20% and not different from nonwheezers.

Lung function in the Tucson CRS was measured in the first year of life (before the occurrence of lower respiratory tract infections) and at 6 years of age. Interestingly, transient wheezers had the lowest airflow measures in infancy, suggesting that they had the narrowest airways and/or the smallest lungs at birth.<sup>16</sup> Their reduced lung function improved significantly by age 6 years, but continued to be lower than normal at age 16 years.<sup>17</sup>

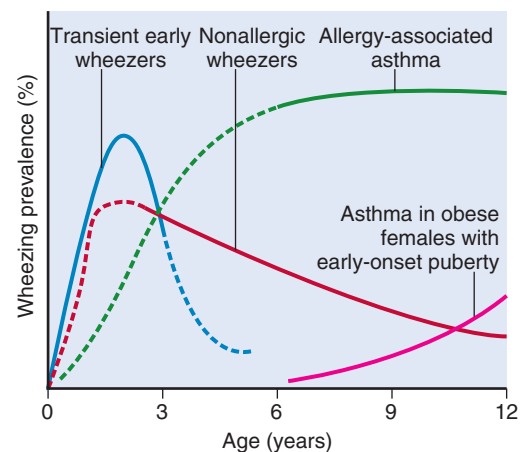

**Figure 2-2** Hypothetical yearly prevalence for recurrent wheezing phenotypes in childhood (Tucson Children’s Respiratory Study, Tucson, Arizona). This classification does not imply that the groups are exclusive. Dashed lines suggest that wheezing can be represented by different curve shapes resulting from many different factors, including overlap of groups. (Modified from Stein RT, Holberg CJ, Morgan WJ, et al. *Thorax* 1997;52:946–52.)

In comparison, persistent wheezers demonstrated normal lung function in the first few months of life but a significant decline in airflow measures by 6 years of age that persisted as lower than normal at age 16 years.<sup>17</sup> Therefore, lung function in transient early and persistent wheezers remained lower than normal non-wheezers through age 16 years, indicating two different clinical patterns of recurrent wheezing in early childhood that are associated with persistently low lung function established early in life.

Some children with BHR in early life are also more likely to have persistent asthma. Investigators of a birth cohort in Perth, Australia, found that BHR at 1 month of age was associated with lower lung function (i.e. FEV<sub>1</sub> and FVC) and a higher likelihood of asthma at 6 years of age.<sup>18</sup> Interestingly, congenital BHR was not associated with total serum IgE, eosinophilia, allergen sensitization or BHR at 6 years of age and was independent of gender, family history of asthma and maternal smoking. In the Tucson CRS study, BHR measured at age 6 years predicted chronic and newly diagnosed asthma at age 22 years.<sup>19</sup>

## Asthma from Childhood to Adulthood

A cohort of 7-year-old children with asthma living in Melbourne, Australia, was restudied for persistence and severity of asthma at 10, 14, 21, 28, 35 and 42 years of age. At 42 years of age, 71% of the asthmatics and 89% of the severe asthmatics continued to have asthma symptoms; 76% of the severe asthmatics reported frequent or persistent asthma.<sup>20</sup> In comparison, 15% of 'mild wheezy bronchitics' (i.e. wheezing only with colds at 7 years of age) and 28% of 'wheezy bronchitics' (i.e. at least five episodes of wheezing with colds) reported frequent or persistent asthma. These observations – that many children with asthma experience disease remission or improvement in early adulthood but that severe asthma persists with age – are remarkably similar to those of several other natural history studies of childhood asthma into adulthood.<sup>21–24</sup>

Spirometric measures of lung function of the Melbourne study children initially revealed that asthmatics (especially severe asthmatics) had lung function impairment, whereas wheezy bronchitics (i.e. 'transient' wheezers) had lung function that was not different from that of nonasthmatics. Over the ensuing years these differences in lung function impairment between groups persisted in parallel, without a greater rate of decline in lung function in any group (Figure 2-3).<sup>20,25</sup> Beginning from birth, in the Tucson CRS, low lung function in infancy also persisted through ages 11, 16 and 22 years.<sup>26</sup> However, some children with persistent asthma demonstrated progressive decline in lung function. In the longitudinal CAMP study, approximately 25% of elementary school-age children with persistent asthma manifested progressive decline in lung function annually for 4 years.<sup>27</sup> Risk factors for progressive decline in lung function included male gender, younger age and hyperinflation. These findings support the importance of the early childhood years in lung and asthma development. The establishment of chronic disease and lung function impairment in early life appears to predict persistent asthma and lung dysfunction well into adulthood; however, progressive decline in lung function can occur in some children during school-age years.

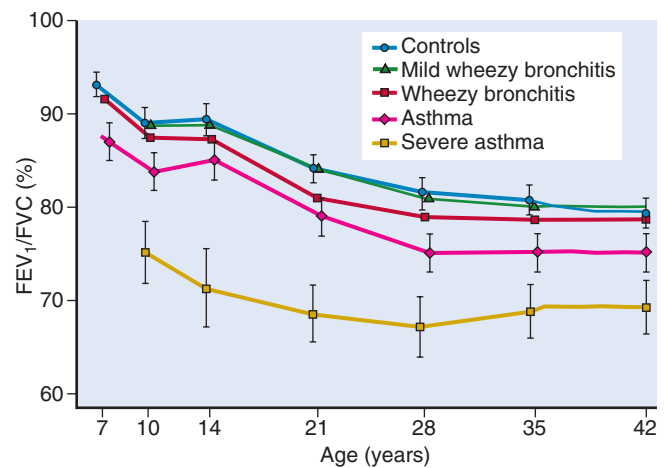

**Figure 2-3** Natural history of lung function from childhood to adulthood (Melbourne Longitudinal Study of Asthma, Melbourne, Australia). Subjects were classified according to their diagnosis at time of enrollment: nonwheezing control; mild wheezy bronchitis; wheezy bronchitis; asthma; and severe asthma. Lung function is represented as FEV<sub>1</sub> corrected for lung volume (FEV<sub>1</sub>/FVC ratio). Mean values and standard error bars are shown. (Adapted from Oswald H, Phelan PD, Lanigan A, et al. *Pediatr Pulmonol* 1997;23:14–20; with data for age 42 years from Horak E, Lanigan A, Roberts M, et al. *BMJ* 2003; 326(7386):422–3.)

### BOX 2-2 KEY CONCEPTS

#### Risk Factors for Persistent Asthma

##### ALLERGY

- Atopic dermatitis
- Allergic rhinitis
- Elevated total serum IgE levels (first year of life)
- Peripheral blood eosinophilia >4% (2 to 3 years of age)
- Inhalant and food allergen sensitization

##### GENDER

###### Males

- Transient wheezing
- Persistent allergy-associated asthma

###### Females

- Asthma associated with obesity and early-onset puberty
- 'Triad' asthma (adulthood)

##### PARENTAL ASTHMA

##### LOWER RESPIRATORY TRACT INFECTIONS

- Rhinovirus, respiratory syncytial virus
- Severe bronchiolitis (i.e. requiring hospitalization)
- Pneumonia

##### ENVIRONMENTAL TOBACCO SMOKE EXPOSURE (INCLUDING PRENATAL)

## Risk Factors for Persistent Asthma

Natural history studies of asthma have identified biologic, genetic and environmental risk factors for persistent asthma (Box 2-2). From the Tucson CRS, a statistical optimization of the major risk factors for persistent childhood asthma provided 97% specificity and 77% positive predictive value for persistent asthma in later childhood (Figure 2-4).<sup>28</sup>



At least 4 wheezing episodes, plus:	
1 Major criterion	or 2 Minor criteria
Parental asthma	Allergic rhinitis
Eczema	Wheezing apart from colds
Inhalant allergen sensitization	Eosinophils $\geq$ 4%
	Food allergen sensitization

**Figure 2-4** Modified Asthma Predictive Index for children (Tucson Children's Respiratory Study, Tucson, Arizona). Through a statistically optimized model for 2- to 3-year-old children with frequent wheezing in the past year, one major criterion or two minor criteria provided 77% positive predictive value and 97% specificity for persistent asthma in later childhood. (Adapted from Castro-Rodriguez JA, Holberg CH, Wright AL, et al. *Am J Respir Crit Care Med* 2000;162:1403–6; and Guilbert TW, Morgan WJ, Zeiger RS, et al. *J Allergy Clin Immunol* 2004;114:1282–7.)

## ALLERGY

Essentially all of the current natural history studies have found that allergic disease and evidence of pro-allergic immune development are significant risk factors for persistent asthma. For example, in the Tucson CRS, early AD, AR, elevated serum IgE levels in the first year of life and peripheral blood eosinophilia were all significant risk factors for persistent asthma.<sup>16,28</sup> In the Berlin MAS study, additional risk factors for asthma and BHR at age 7 years included persistent sensitization to foods (i.e. hen's egg, cow's milk, wheat and/or soy) and perennial inhalant allergens (i.e. dust mite, cat dander), especially in early life.<sup>29,30</sup> The combination of allergic sensitization to major indoor allergens (dog, cat and/or mite) by age 3 years with higher levels of allergen exposure in the home was associated with persistent wheezing and lower lung function into adolescence.<sup>31</sup> In the Kaiser San Diego study, milk or peanut allergen sensitization was a risk factor for asthma.<sup>32</sup> Natural history studies of asthma that have extended into adulthood continue to find allergy to be a risk factor for persistent asthma.<sup>22,23</sup> Since the eight-center Childhood Asthma Management Program (CAMP) study of 1,041 asthmatic children ages 5 to 12 years found that 88% were sensitized to at least one inhalant allergen at study enrollment, allergy-associated asthma appears to be the most common form of asthma in elementary school-age children in the USA.<sup>33</sup> Furthermore, in the International Study of Asthma and Allergies in Childhood (ISAAC), strong correlations between high asthma prevalence and both high allergic rhinoconjunctivitis and high AD prevalence in different sites throughout the world suggest that allergy-associated asthma is also the most common form of childhood asthma worldwide.<sup>34</sup> In children with recurrent cough or wheeze in early life, early manifestations of atopy are well-regarded predictive risk factors for persistent lung dysfunction and clinical disease (Figure 2-4).<sup>35,36</sup>

## GENDER

Male gender is a risk factor for both transient wheezing and persistent asthma in childhood.<sup>16,32</sup> This is generally believed to be caused by the smaller airways of young boys when compared with girls.<sup>37,38</sup> Later in childhood, BHR and inhalant allergen

sensitization are more prevalent in boys than in girls.<sup>39,40</sup> For asthma persistence from childhood to adulthood, female gender is a risk factor for greater asthma severity<sup>22</sup> and BHR.<sup>21</sup> Female children who become overweight and have early-onset puberty are also more likely to develop asthma in adolescence, an association not appreciated in males (see Figure 2-2).<sup>41</sup> These observations are consistent with the gender 'flip' in asthma prevalence – higher in males in childhood, and in females by adulthood.<sup>15</sup>

## PARENTAL HISTORY OF ASTHMA

Infants whose parents report a history of childhood asthma have lower lung function and are more likely to wheeze in early life,<sup>42,43</sup> in later childhood<sup>16,32</sup> and in adulthood.<sup>22</sup> However, in a two-generation, longitudinal study in Aberdeen, Scotland, the children of well-characterized subjects without atopy or asthma were found to have a surprisingly high prevalence of allergen sensitization (56%) and wheezing (33%).<sup>44</sup> Similarly, in the MAS study, the majority of children with AD and/or asthma in early childhood were born to nonallergic parents.<sup>45</sup> For example, of the study's asthmatic children at 5 years of age, 57% were born to parents without an atopic history. Therefore allergen sensitization and asthma seem to be occurring at high rates, even in persons considered to be at low genetic risk for allergy and asthma.

## LOWER RESPIRATORY TRACT INFECTIONS

Certain respiratory viruses have been associated with persistent wheezing problems in children. It is not known if persistent airways abnormalities are primarily the result of virus-induced damage, vulnerable individuals revealing their airway susceptibility to virus-induced airflow obstruction, or airways injury with aberrant repair. In long-term studies, infants hospitalized with respiratory syncytial virus (RSV) bronchiolitis (most occurred by 4 months of age) were significantly more likely to have asthma and lung dysfunction through age 13 years.<sup>46</sup> In the Tucson CRS birth cohort, 91% of lower respiratory tract infections (LRTIs) in the first 3 years of life were cultured for common pathogens: 44% were RSV-positive, 14% were parainfluenza-positive, 14% were culture-positive for other respiratory pathogens, and 27% were culture-negative.<sup>47</sup> Followed prospectively, infants with RSV LRTI were more likely to have wheezing symptoms at 6 years of age but not at later ages (i.e. 11 and 13 years old). However, young children who had radiographic evidence of pneumonia or croup symptoms accompanying wheezing were more likely to have persistent asthma symptoms and lung function impairment at 6 and 11 years of age.<sup>48,49</sup>

Improved PCR-based detection methods have affirmed a strong association between rhinovirus infection and asthma exacerbations, such that approximately 40% to 70% of wheezing illnesses and asthma exacerbations in children can be attributed to rhinovirus.<sup>50–52</sup> People with asthma do not appear to be more susceptible to rhinovirus infection, but they are more likely to develop an LRTI with symptoms that are more severe and longer lasting.<sup>53</sup> In the Childhood Origins of Asthma (COAST) birth cohort study, 90% of children with rhinovirus-associated wheezing episodes at age 3 years had asthma at age 6 years, such that a rhinovirus-associated wheezing episode at age 3 years was a stronger predictor of subsequent asthma than

aeroallergen sensitization (odds ratios 25.6 vs 3.4).<sup>54</sup> This supports the premise that individuals with lower airway vulnerability to common respiratory viruses are at risk for wheezing episodes and persistent asthma.

## ENVIRONMENTAL TOBACCO SMOKE EXPOSURE

ETS exposure is a risk factor for wheezing problems at all ages. Prenatal ETS exposure is associated, in a dose-dependent manner, with wheezing manifestations and decreased lung function in infancy and early childhood.<sup>55,56</sup> Postnatal ETS exposure is associated with a greater likelihood of wheezing in infancy,<sup>43</sup> transient wheezing, and persistent asthma in childhood.<sup>16</sup> Cigarette smoking has also been strongly associated with persistent asthma and asthma relapses in adulthood.<sup>23</sup>

ETS exposure is also associated with food allergen sensitization,<sup>57</sup> AR, hospitalization for LRTIs, BHR and elevated serum IgE levels.<sup>58,59</sup> In a 7-year prospective study, ETS exposure was associated with greater inhalant allergen sensitization and reduced lung function.<sup>32</sup>

## Asthma- and Allergy-Protective Influences

Some lifestyle differences may impart asthma- and/or allergy-protective effects. Natural history studies have started to contribute some epidemiologic evidence in support of these hypotheses.

### BREASTFEEDING

Numerous studies have investigated the potential of early breastfeeding as a protective influence against the development of allergy and asthma. Meta-analyses of prospective studies of exclusive breastfeeding for 4 or more months from birth have been associated with less AD and asthma (summary odds ratios of 0.68 and 0.70, respectively).<sup>60,61</sup>

### MICROBIAL EXPOSURES

Numerous epidemiologic studies have found that a variety of microbial exposures are associated with a lower likelihood of allergen sensitization, allergic disease and asthma. This has led to a 'hygiene' hypothesis, which proposes that the reduction of microbial exposures in childhood in modernized locales has led to the rise in allergy and asthma.<sup>62</sup> Microbes and their molecular components are believed to influence early childhood development by inducing Th1-type and regulatory immune development and immune memory, thereby preventing the development of allergen sensitization and diseases, while strengthening the immune response and controlling inflammation to common respiratory viral infections.

To address this hypothesis, natural history studies have begun to explore the relationships between microbes and their components (e.g. home environmental bacterial endotoxin) to the development of allergies and asthma:

1. In the Tucson CRS, children raised in larger families or in daycare from an early age (believed to be surrogate measures for more respiratory infections and microbial exposures) were less likely to have asthma symptoms in later

childhood.<sup>63</sup> In the German MAS study, more runny nose colds in the first 3 years of life were associated with a lower likelihood of allergen sensitization, asthma and BHR at 7 years of age.<sup>64</sup> A dose-dependent effect was observed, such that children who experienced at least eight colds by age 3 years had an adjusted odds ratio of 0.16 for asthma at age 7 years.

2. In infants and children, higher house dust endotoxin levels were associated with less AD,<sup>65–67</sup> inhalant allergen sensitization,<sup>68–71</sup> AR and asthma.<sup>72,73</sup> Complementary immunologic studies reveal that higher house dust endotoxin levels were associated with increased proportions of Th1-type cells,<sup>68</sup> higher levels of IFN- $\gamma$  from stimulated peripheral blood samples<sup>74,75</sup> and immune down-regulation of endotoxin-stimulated blood samples.<sup>72</sup> In contrast to these atopy-protective influences, higher endotoxin levels were associated with more wheezing, even when a protective effect on atopy in early life was concurrently observed.<sup>65,67,69,72,76</sup>
3. Gastrointestinal (GI) microbiota shape early immune development, and some investigators identified differences in stool bacteria from newborns and infants who ultimately go on to develop allergic disease as being less diverse and having more clostridia and *Staphylococcus aureus*, while nonallergic infants had more enterococci, bifidobacteria, lactobacilli and *Bacteroides*.<sup>77–81</sup> Alterations in the gut microbiome of infants from dietary and environmental differences (e.g. breastfeeding, semi-sterile food, infections, antibiotic use, siblings, pets) may influence the developing immune system and allergy outcomes.
4. Diverse environmental microbiomes associated with animal exposures may exert a protective influence on the development of asthma. In Europe, farm versus non-farm children were exposed to a greater diversity of bacteria and fungi in their mattress dust, and diversity of microbial exposure was inversely related to asthma risk.<sup>82</sup> Interestingly, in US inner city locales known for a higher prevalence of severe asthma, cockroach, mouse and cat allergen exposure in the first year of life was inversely associated with recurrent wheeze (odds ratios 0.60–0.75).<sup>83</sup> Cockroach and mouse exposure were associated with bacterial Bacteroidetes and Firmicutes phyla in house dust samples, which were associated with lack of atopy and wheeze.

Conversely, some microbial exposures have been associated with the development of persistent asthma. Nasopharyngeal carriage of common respiratory pathogens (*Streptococcus pneumoniae*, *Moraxella catarrhalis*, *Haemophilus influenzae*) in infancy, and in children with asthma in later childhood (*S. pneumoniae*, *M. catarrhalis*), was associated with asthma exacerbations, implicating these respiratory pathogens as co-exposures in the pathogenesis of asthma persistence and exacerbations.<sup>84,85</sup>

### PET OWNERSHIP

Multiple longitudinal birth cohort studies have observed dog and/or cat ownership to be associated with a lower likelihood of AD, allergen sensitization and asthma.<sup>86–88</sup> Similarly, in farming and rural locales, a lower likelihood of allergy and asthma has been associated with animal contact or the keeping

of domestic animals in the home.<sup>89</sup> Two meta-analyses of numerous studies of domestic animal exposure and allergy and asthma outcomes generally found a protective effect.<sup>90,91</sup> Although the mechanism(s) for this protective association is unclear, one possibility is that greater bacterial exposure occurs with animal contact and/or animal/petkeeping in the home. Indoor pets are a major factor associated with higher indoor endotoxin levels in metropolitan homes.<sup>89</sup> Bacterial community diversity in house dust samples from households with pet dogs, and some with cats, is increased.<sup>92</sup>

## VITAMIN D

There is current conjecture that vitamin D supplementation can prevent allergy and asthma. It has been hypothesized that modern lifestyles with greater time spent indoors have fostered more vitamin D deficiency, resulting in more asthma and allergy.<sup>93,94</sup> The scientific rationale is appealing: vitamin D has been shown to bolster innate antimicrobial and regulatory T lymphocyte responses.<sup>93</sup> Complementing this mechanistic science, three birth cohort studies have observed that high maternal vitamin D intake during pregnancy was associated with a lower risk of recurrent/persistent wheeze or asthma in preschool childhood.<sup>95–97</sup> Clinical trials to determine the potential preventive benefits of vitamin D supplementation on allergy and asthma are ongoing.

## Childhood Asthma Phenotypes

Different severity phenotypes of children with persistent asthma have recently been characterized using cluster analysis. In the Childhood Asthma Management Program (CAMP) study, five main phenotypes were distinguished: (1) ‘mild asthma’ with low atopy, airways obstruction and exacerbation rate; (2) atopic asthma with atopic dermatitis/allergic rhinitis/allergic sensitization, normal lung function and low exacerbation rates; (3) high allergic rhinitis/allergic sensitization, reduced lung function and moderate exacerbation rates; (4) reduced lung function and high bronchodilator responses, BHR and exacerbation/hospitalization rates; and (5) the highest atopy/serum IgE/eosinophilia, reduced lung function, high bronchodilator responses/BHR, and the highest exacerbation and hospitalization rates.<sup>98</sup> Children in these different clusters appeared to be temporally stable over the 5 years of the CAMP study, with mild versus severe diverging over time. These clusters were consistent with those identified in the Severe Asthma Research Program (SARP).<sup>99</sup> The most severe phenotype in children appears consistent with a severe ‘Th2-high’ phenotype in adults, with IL-13-induced epithelial gene expression (e.g. periostin), atopic airways inflammation and exacerbation risk.<sup>100</sup>

Asthma mediated by occupational-type exposures is often not considered in children, and yet some children are raised in settings where occupational-type exposures can mediate asthma in adults (e.g. on farms or with farm animals in the home). Children with hypersensitivity and exposure to other common airways irritants or air pollutants such as ETS, endotoxin, ozone, sulfur dioxide or cold air may also contribute to the pool of nonatopic children with persistent asthma. ‘Triad’ asthma, characteristically associated with hyperplastic sinusitis/nasal polyposis and/or hypersensitivity to nonsteroidal anti-inflammatory medications (e.g. aspirin, ibuprofen), rarely occurs in childhood.

## Atopic Dermatitis

AD usually begins during the preschool years and persists throughout childhood. Two prospective birth cohort studies have found the peak incidence of AD to be in the first 2 years of life (see [Figure 2-1](#)).<sup>32,101</sup> Although 66% to 90% of patients with AD have clinical manifestations before 7 years of age,<sup>102,103</sup> eczematous lesions in the first 2 months of life are rare. Natural history studies of AD have reported a wide variation (35% to 82%) in disease persistence throughout childhood.<sup>103,104</sup> The greatest remission in AD seems to occur between 8 and 11 years of age and, to a lesser extent, between 12 and 16 years.<sup>103</sup> Natural history studies of AD may have underestimated the persistent nature of the disease for reasons that include (1) AD definition – some studies have included other forms of dermatitis that have a better prognosis over time (i.e. seborrheic dermatitis),<sup>105</sup> (2) AD recurrence – a recent 23-year birth cohort study found that many patients who went into disease remission in childhood had an AD recurrence in early adulthood,<sup>103</sup> and (3) AD manifestation – it is generally believed that patients with childhood AD will often evolve to manifest hand and/or foot dermatitis as adults.

Parental history of AD is an important risk factor for childhood AD. This apparent heritability complements studies revealing a high concordance rate of AD among monozygotic versus dizygotic twins (0.72 vs 0.23, respectively).<sup>106</sup> In a risk factor assessment for AD in the first 2 years of life, higher levels of maternal education and living in less crowded homes were risk factors for early-onset AD.<sup>107</sup> The environmental/lifestyle risk factors reported for AR and asthma are similar. A meta-analysis of prospective breastfeeding studies concluded that exclusive breastfeeding of infants with a family history of atopy for at least the first 3 months of life is associated with a lower likelihood of childhood AD (odds ratio 0.58). This protective effect was not observed, however, in children without a family history of atopy.<sup>60</sup>

Initial AD disease severity seems predictive of later disease severity and persistence. Of adolescents with moderate to severe AD, 77% to 91% continued to have persistent disease in adulthood.<sup>108</sup> In comparison, of adolescents with mild AD, 50% had AD in adulthood. Food allergen sensitization and exposure in early childhood also contribute to AD development and disease severity. Food allergen sensitization is associated with greater AD severity.<sup>32,109</sup> Furthermore, elimination of common allergenic foods in infancy (i.e. soy, milk, egg, peanuts) is associated with a lower prevalence of allergic skin conditions up to age 2 years (see [Figure 2-1](#)).<sup>32</sup>

Natural history studies have found early childhood AD to be a major risk factor for food allergen sensitization in infancy,<sup>110</sup> inhalant allergen sensitization<sup>110,111</sup> and persistent asthma in later childhood.<sup>16,28</sup> In particular, severe AD in early childhood is associated with a high prevalence of allergen sensitization and airways allergic disease in later childhood (i.e. 4 years later; [Figure 2-5](#)). Indeed, in young patients with severe AD, 100% developed inhalant allergen sensitization and 75% developed an allergic respiratory disease (mostly asthma) over 4 years. In contrast to severe AD, patients with mild to moderate AD were not as likely to develop allergen sensitization (36%) or an allergic respiratory disease (26%). More information on current concepts of barrier and immune dysfunction in AD, and the role of food hypersensitivity, can be found in Chapters 50 and 47, respectively.

Initial examination			4 years later		
AD severity	Inhalant ± food	Food only	Inhalant ± food	Food only	Asthma and/or AR
Mild	15%	20%	31%	6%	15%
Moderate	18%	26%	52%	6%	32%
Severe	20%	45%	100%	0%	75%

**Figure 2-5** Atopic dermatitis (AD) in young children (2 months to 3 years of age) and allergen sensitization (to food and inhalant allergens), asthma and allergic rhinoconjunctivitis (AR) 4 years later. At enrollment, AD severity was determined, and no subjects had AR or asthma. Four years later, 88% of subjects had a marked improvement or complete resolution of AD. However, all children with severe AD at enrollment were sensitized to inhalant allergens, and 75% had asthma and/or AR. (From Patrizi A, Guerrini V, Ricci G, et al. *Pediatr Dermatol* 2000; 17:261–5.)

## Allergic Rhinitis

Many people develop AR during childhood. Two prospective birth cohort studies reported a steady rise in total (i.e. seasonal and perennial) AR prevalence, reaching 35% to 40% by age 7 years.<sup>32,112</sup> Seasonal AR emerged after 2 years of age and increased steadily to 15% by age 7 years.<sup>112</sup>

AR also commonly begins in early adulthood. In a 23-year cohort study of Brown University students, beginning in their freshman year, perennial AR developed in 4.8% at 7 years and 14% at 23 years of follow-up.<sup>2,3</sup> The incidence increase for seasonal AR was substantially greater: 13% at 7 years and 41% at 23 years of follow-up.<sup>2,3</sup> Allergen skin test sensitization and asthma were prognostic risk factors for the development of AR.

AR persistence has been evaluated in adult patients. Three follow-up studies of adult AR patients found a disease remission rate of 5% to 10% by 4 years<sup>113</sup> and 23% by 23 years.<sup>2</sup> In the 23-year follow-up study, 55% of the follow-up subjects reported improvement in rhinitis. Onset of disease in early childhood was associated with greater improvement.<sup>2</sup>

## Food Allergy

Food-adverse reactions in childhood include food hypersensitivity that is IgE mediated and manifests as classic allergic symptoms of immediate onset. Other food-allergic reactions, such as eosinophilic gastroenteropathy and food protein-induced enterocolitis syndrome, have variable associations with foods and lack natural history studies.

Natural history studies reveal that the prevalence of food hypersensitivity is greatest in the first few years of life, affecting 5% to 15% of children in their first year of life.<sup>114,115</sup> Most children become tolerant of or seem to 'outgrow' their food allergies to milk, soy and egg within a few years. In a prospective study of young children with milk allergy, most became nonallergic within a few years: 50% by 1 year of age, 70% by 2 years, and 85% by 3 years.<sup>116</sup> Older children and adults with food allergies are less likely to become tolerant (26% to 33%).<sup>117,118</sup> Long-term follow-up studies of peanut-allergic children found that loss of clinical hypersensitivity was uncommon, especially in children with anaphylactic symptoms in addition to urticaria and/or AD.<sup>119,120</sup> Allergies to other nuts, fish and shellfish are also believed to be more persistent. It is purported that allergen avoidance diets in food-allergic children increase their

likelihood of losing clinical hypersensitivity, but this has not been well studied.<sup>118</sup>

Hypersensitivity to milk at 1 year of age was a risk factor for additional food allergies in later childhood.<sup>121,122</sup> Furthermore, food hypersensitivity in early life (i.e. to milk, egg, peanut) was found to be a risk factor for AD<sup>123,124</sup> and, later, asthma.<sup>29,32</sup> More information on the natural history and prevention of food allergy can be found in Chapter 43.

## Anaphylaxis

Anaphylaxis in children can result from numerous possible exposures (e.g. foods, antibiotics, insulin, insect venoms, latex) and is sometimes anaphylactoid (a clinically similar but non-IgE-mediated reaction, such as occurs with radio-contrast media and aspirin/nonsteroidal antiinflammatory drugs) or idiopathic. In a retrospective medical records review of 601 cases, causes of anaphylaxis were determined in 41%: foods 22%, medications 11% and exercise 5%. Episodes tended to become less frequent over time.<sup>125</sup> A history of AR or asthma is a risk factor for anaphylaxis to foods and latex.<sup>126</sup> Surprisingly, a history of asthma, pollenosis or food and/or drug allergy is a risk factor for anaphylactoid reactions to radio-contrast media, with a higher prevalence of adverse reactions to ionic versus nonionic contrast media observed.<sup>127</sup> In contrast, atopy is not a risk factor for anaphylaxis to insulin,<sup>128</sup> penicillin<sup>129</sup> or insect stings.<sup>130</sup> The natural history of anaphylactic reactions in children has been studied prospectively only for food-induced anaphylaxis (described previously) and bee sting anaphylaxis.

In a Johns Hopkins study examining the natural history of bee venom allergy in children, venom-allergic children with a history of mild generalized reactions were randomly assigned to venom immunotherapy or no treatment and then subjected to a repeat sting in a medical setting 4 years later.<sup>131</sup> Systemic allergic reactions occurred in 1.2% of the treated group and 9.2% of the untreated group. Moreover, systemic reactions that occurred were no more severe than the original incidents. In a smaller study of children and adults with venom hypersensitivity, repeat sting challenges, at least 5 years after the original incidents, induced no systemic reactions in those who originally presented with only urticaria/angioedema but did induce systemic reactions in 21% of those who originally had respiratory and/or cardiovascular complications.<sup>132</sup>

These studies suggest that insect sting anaphylaxis is often self-limited in children, with spontaneous remission usually occurring within 4 years. Those at greatest risk of persistent hypersensitivity include those with previous severe anaphylactic episodes. Conversely, those children with mild systemic reactions to bee stings are less likely to have an allergic reaction on re-sting, and any future anaphylactic episodes from bee stings are not likely to be severe. Finally, in a re-challenge study of subjects with no clinical response to a first sting challenge, 21% experienced anaphylaxis to the second challenge, and, of those, one half developed symptomatic hypotension requiring epinephrine.<sup>133</sup>

## Gene-Environment Interactions

Gene-environment interactions validate the central paradigm that allergy and asthma development results from common environmental exposures affecting the inherently susceptible host. There are two notable examples related to childhood asthma:



1. *CD14, endotoxin and dogs*: Polymorphisms in genes encoding proteins that mediate endotoxin recognition can modify endotoxin responsiveness. A common polymorphism in the promoter region (-260C-to-T) of the CD14 gene (endotoxin promoter/enhancer protein) has been one of the most studied polymorphisms with regard to asthma and allergies. Functionally, the -260CT CD14 promoter polymorphism alters the transcriptional regulation of CD14; the T allele increases CD14 transcription by reducing the binding of proteins that inhibit gene transcription.<sup>134</sup> Some studies have found that the C allele of the -260 CD14 promoter polymorphism increases the risk for allergic sensitization,<sup>135,136</sup> while others have not.<sup>137,138</sup> Furthermore, some studies show this allele to have either protective or risk effects, depending on the type of environment in which the individual lives. These discrepancies are likely to be a consequence of different levels of exposure to endotoxin or similar microbial components. For example, in a birth cohort study, only the low-responder, 'CC' homozygous group demonstrated strong dose-response relationships between higher house dust endotoxin levels and less subsequent allergic sensitization to inhalant allergens, less AD and more nonatopic wheeze.<sup>139</sup> Similarly, the C allele was found to be protective in children living in a subset of homes where measured endotoxin levels were high.<sup>140</sup> In another birth cohort study, the protective effect of dog ownership on AD in infancy occurred only in those who were of the CD14 'TT' genotype.<sup>88</sup>
2. *Glutathione S-transferases (GSTs), environmental tobacco smoke (ETS) and diesel exhaust*: Genetic susceptibility to common air pollutant exposures increases the risk of childhood asthma. For example, polymorphisms in the endogenous antioxidant GST genes (e.g. *GST-M1* null) were associated with less asthma in children; these associations were strengthened when genetic GST susceptibility was combined with maternal smoking.<sup>141-143</sup> In a longitudinal birth cohort study, diesel exhaust particulate exposure was associated with persistent wheezing only in those children carrying a specific genotypic variant in *GST-P1* (valine at position 105).<sup>144</sup> Similar to the GST polymorphisms, genetic variants in chromosome 17q21 increased the risk of early-onset asthma; this risk was further increased by early ETS exposure.<sup>145</sup>

These findings demonstrate how ordinary environmental exposures conspire with genetic susceptibilities to exert stronger effects on the development of asthma and allergy than either genes or environmental exposures alone.

## Prevention Studies

Early-intervention studies to prevent the development of allergic disease and asthma have had limited success so far. Nevertheless, because of their prospective design, such studies can add valuable insights to the natural history of allergic diseases.

### AVOIDANCE VERSUS EARLY INTRODUCTION OF ALLERGENIC FOODS

In a 7-year randomized, controlled intervention study (Kaiser Permanente San Diego), in which the common allergenic foods (cow's milk, peanut, egg, fish) were eliminated from the diets of at-risk infants (i.e. one parent with an atopic disorder and allergen sensitization) from the third trimester of pregnancy to 24

months of life, the prevalence of food allergen sensitization, AD and urticarial rash was reduced in the first year of life,<sup>115</sup> but did not persist at either age 4 or 7 years, and no effect was observed on inhalant allergen sensitization or allergic airways conditions<sup>32</sup> (see Figure 2-1).

In contrast, in observational studies, introduction of allergenic foods in early infancy has been associated with a lower prevalence of specific food allergy. Infants introduced to egg at 4 to 6 months of age had a significantly lower risk of egg allergy, especially if first exposed to cooked egg (as opposed to egg in baked goods).<sup>146</sup> A 10-fold higher prevalence of peanut allergy in Jewish children in the UK versus Israel was linked to dietary differences: Israeli infants consume peanuts in a teething biscuit, while UK infants avoid peanuts.<sup>147</sup> A clinical trial to determine if early introduction of peanut in infants' diets can prevent peanut allergy by oral tolerance induction is ongoing (Learning Early About Peanut Allergy [LEAP] study).<sup>148</sup>

### INHALANT ALLERGEN ELIMINATION/REDUCTION

Randomized clinical trials of home inhalant allergen reduction beginning pre birth have had mixed results. An intensive indoor allergen reduction intervention did not affect the risk of respiratory symptoms, wheeze, rhinitis or AD at age 3 years; although intervention was associated with a higher prevalence of allergic sensitization, it was conversely associated with better lung function, i.e. lower airways resistance.<sup>149</sup> Addition of thorough dust mite reduction measures to food allergen avoidance for 1 year reduced the likelihood of AD from 1 to 4 years of age and reduced the incidence of allergen sensitization at age 4 years.<sup>150-152</sup> Decreased asthma was observed in the first year of life but not at age 2 or 4 years. An intervention including house dust, pets and ETS avoidance, breastfeeding and delayed introduction of solid foods was associated with a lower risk of asthma at age 7 years; BHR, allergic sensitization, AR and AD were not affected.<sup>153</sup> A systematic review and meta-analysis of three multifaceted and six monofaceted allergen reduction trials suggested that reduction in exposure to multiple indoor allergens, but not monoallergen interventions, modestly reduced the likelihood of asthma in children.<sup>154</sup> The modest effect of these allergen reduction interventions may be attributable to the partial effectiveness of these specific interventions in lowering home allergen levels, allergen exposure that occurs outside of the home, and the potential unintended effect of the interventions on other environmental disease modifiers (e.g. endotoxin). Improving allergen reduction/elimination (i.e. dehumidification<sup>155</sup>) could potentially be more effective. Dust mite-sensitive children with asthma who have been moved to high-altitude locales without dust mite allergen,<sup>156,157</sup> or whose bedrooms have undergone extensive mite reduction measures,<sup>60,61,158</sup> experience significant asthma improvement, sometimes dramatically.

### BREASTFEEDING

This has been addressed in prospective studies discussed earlier in this chapter.

### ENVIRONMENTAL TOBACCO SMOKE ELIMINATION/REDUCTION

The acquisition of definitive proof of the preventive value of reducing or eliminating ETS exposure in infancy and childhood

has been hindered by the difficulties in achieving long-term smoking cessation in randomized, controlled studies. ETS exposure at all ages, from prenatal exposure of mothers to smoking in asthmatic adults, is associated with more wheezing problems and more severe disease and is discussed earlier in this chapter. When considered with other health benefits of ETS exposure avoidance, this is strongly recommended.

## Pharmacologic Intervention

Several studies have attempted to determine if conventional therapy for allergy and asthma may be able to alter the natural course of the allergic march or to prevent persistent allergic disease and chronic asthma.

### ANTIHISTAMINES

In the Early Treatment of the Atopic Child (ETAC) study, the antihistamine cetirizine was administered for 18 months to young children at high risk for asthma. Of subjects receiving cetirizine, only young children with early allergen sensitization to mites or grass pollen were less likely to develop asthma symptoms.<sup>159,160</sup>

### CONVENTIONAL 'CONTROLLER' PHARMACOTHERAPY FOR ASTHMA

In the CAMP study, 5- to 12-year-old children were treated with daily inhaled corticosteroid (ICS, budesonide), daily inhaled nonsteroidal antiinflammatory medication (nedocromil) or placebo for more than 4 years; treatment was then discontinued.<sup>29</sup> During treatment, the ICS-treated subjects demonstrated significant improvement in most of the clinical outcomes and lung function measures of asthma. After ICS discontinuation, however, the ICS-treated group regressed to that of the placebo group. Nedocromil-treated subjects did not improve. This suggests that, although long-term ICS administration in school-age children with asthma improves asthma severity, it does not alter its natural course.

Similarly, randomized controlled trials with ICS administered earlier in life have not demonstrated a preventive effect on persistent asthma. Daily or intermittent 2-week ICS courses administered to infants for episodic wheezing did not improve asthma, wheeze or lung function outcomes in later childhood.<sup>161,162</sup> Daily ICS administered for 2 years to toddler-age children meeting modified asthma predictive indices for persistent asthma (Figure 2-4) improved clinical asthma while on treatment, but did not affect asthma persistence during a third treatment-free year.<sup>163</sup> As a meta-analysis of 29 studies of infants and preschoolers with recurrent wheezing or asthma concluded, daily ICS improves respiratory symptoms, exacerbations and lung function, but does not appear to improve the natural course of asthma.<sup>164</sup>

### ALLERGEN-SPECIFIC IMMUNOTHERAPY

Allergen-specific immunotherapy (AIT) has been studied to determine if it can reduce the likelihood of asthma develop-

ment in children with AR. A recently published randomized, controlled study found that a 3-year AIT course administered to children with birch and/or grass pollen AR reduced rhinoconjunctivitis severity, conjunctival sensitivity to allergen and the likelihood of developing asthma at 2 and 7 years after AIT discontinuation.<sup>165,166</sup> AIT also prevents the development of new sensitization to inhalant allergens.<sup>167,168</sup> These studies suggest that AIT may alter the allergic march of inhalant allergen sensitization and asthma, but the difficulties and risks of conventional AIT in children warrant careful consideration.

### PROBIOTICS

Some studies suggest that oral probiotic supplementation in infancy may prevent atopy by promoting Th1-type and/or regulatory T lymphocyte immune development. In breastfeeding mothers who received lactobacillus supplementation, breast milk had higher concentrations of the antiinflammatory cytokine TGF- $\beta$ , and their infants had a reduced risk of AD of 0.32.<sup>169</sup> Lactobacillus ingestion has also been associated with increased infant peripheral blood IL-10 production and serum IL-10 levels.<sup>170</sup> A meta-analysis of six randomized controlled trials to prevent AD in children, usually beginning with maternal intake before birth, reported less AD in the probiotic-treated group.<sup>171</sup> Other clinical trials with lactobacillus or combined pro-/prebiotics demonstrated reduced respiratory infection illnesses in young children.<sup>172-174</sup> A large randomized controlled trial ( $N = 1,018$ ) of pre-/probiotic supplementation to prevent allergies found no significant differences in allergic sensitization, AD, AR or asthma at 5 years of age; however, it significantly reduced the odds ratio (0.47) of IgE-associated allergic disease in cesarean-delivered children.<sup>175</sup> Differences in the specific probiotic strains used in the different clinical trials may contribute to the differences in findings between studies.

## Conclusions

To summarize, allergic diseases and asthma commonly develop in the early childhood years. Current paradigms of immune development and lung growth shape the understanding of disease pathogenesis. The systemic nature of these conditions is such that manifestations of one allergic condition are often risk factors for others (e.g. AD and allergen sensitization are risk factors for persistent asthma). Although many allergy and asthma sufferers improve and can even become disease-free as adults, those with severe disease and some particular conditions (e.g. peanut allergy) are likely to have lifelong disease.

### ACKNOWLEDGMENT

Our sincere gratitude to our colleague, Dr. Lynn Taussig, for his previous authorship of this chapter and his legacy of natural history investigation in childhood asthma.

The complete reference list can be found on the companion Expert Consult website at <http://www.expertconsult.inking.com>.

## KEY REFERENCES

16. Martinez FD, Wright AL, Taussig LM, Holberg CJ, Halonen M, Morgan WJ. Asthma and wheezing in the first six years of life. *N Engl J Med* 1995;332:133–8.
28. Castro-Rodriguez JA, Holberg CJ, Wright AL, Martinez FD. A clinical index to define risk of asthma in young children with recurrent wheezing. *Am J Respir Crit Care Med* 2000;162:1403–6.
31. Illi S, von Mutius E, Lau S, Niggemann B, Grüber C, Wahn U, et al. Perennial allergen sensitisation early in life and chronic asthma in children: a birth cohort study. *Lancet* 2006;368:763–70.
34. ISAAC Steering Committee. Worldwide variation in prevalence of symptoms of asthma, allergic rhinoconjunctivitis, and atopic eczema: ISAAC. *Lancet* 1998;351:1225–32.
54. Jackson DJ, Gangnon RE, Evans MD, Roberg KA, Anderson EL, Pappas TE, et al. Wheezing rhinovirus illnesses in early life predict asthma development in high-risk children. *Am J Respir Crit Care Med* 2008;178:667–72.
82. Ege MJ, Mayer M, Normand AC, Genuneit J, Cookson WO, Braun-Fahrländer C, et al. Exposure to environmental microorganisms and childhood asthma. *N Engl J Med* 2011;364:701–9.
84. Bisgaard H, Hermansen MN, Buchvald F, Loland L, Halkjaer LB, Bønnelykke K, et al. Childhood asthma after bacterial colonization of the airway in neonates. *N Engl J Med* 2007;357:1487–95.
87. Ownby DR, Johnson CC, Peterson EL. Exposure to dogs and cats in the first year of life and risk of allergic sensitization at 6 to 7 years of age. *JAMA* 2002;288:963–72.
98. Howrylak JA, Fuhlbrigge AL, Strunk RC, Zeiger RS, Weiss ST, Raby BA. Childhood Asthma Management Program Research Group. Classification of childhood asthma phenotypes and long-term clinical responses to inhaled anti-inflammatory medications. *J Allergy Clin Immunol* 2014;133:1289–300, 1300.e1–12.
125. Webb LM, Lieberman P. Anaphylaxis: a review of 601 cases. *Ann Allergy Asthma Immunol* 2006;97:39–43.

## REFERENCES

- Kulig M, Bergmann R, Klettke U, Wahn V, Tacke U, Wahn U. Natural course of sensitization to food and inhalant allergens during the first 6 years of life. *J Allergy Clin Immunol* 1999;103:1173–9.
- Greisner WA, Settupane RJ, Settupane GA. Coexistence of asthma and allergic rhinitis: a 23-year follow-up study of college students. *Allergy Asthma Proc* 1998;19:185–8.
- Hagy GW, Settupane GA. Risk factors for developing asthma and allergic rhinitis: a 7-year follow-up study of college students. *J Allergy Clin Immunol* 1976;58:330–6.
- Prescott SL, Macaubas C, Holt BJ, Smallacombe TB, Loh R, Sly PD, et al. Transplacental priming of the human immune system to environmental allergens: universal skewing of initial T cell responses toward the Th2 cytokine profile. *J Immunol* 1998;160:4730–7.
- Martinez FD, Stern DA, Wright AL, Holberg CJ, Taussig LM, Halonen M. Association of interleukin-2 and interferon- $\gamma$  production by blood mononuclear cells in infancy with parental allergy skin tests and with subsequent development of atopy. *J Allergy Clin Immunol* 1995;96:652–60.
- Burrows B, Sears MR, Flannery EM, Herbison GP, Holdaway MD, Silva PA. Relation of the course of bronchial responsiveness from age 9 to age 15 to allergy. *Am J Respir Crit Care Med* 1995;152:1302–8.
- Sears MR, Burrows B, Flannery EM, Herbison GP, Hewitt CJ, Holdaway MD. Relation between airway responsiveness and serum IgE in children with asthma and in apparently normal children. *N Engl J Med* 1991;325:1067–71.
- Hattevig G, Kjellman B, Johansson SG, Björkstén B. Clinical symptoms and IgE responses to common food proteins in atopic and healthy children. *Clin Allergy* 1984;14:551–9.
- Rowntree S, Cogswell JJ, Platts-Mills TAE, Mitchell EB. Development of IgE and IgG antibodies to food and inhalant allergens in children at risk of allergic disease. *Arch Dis Child* 1985;60:727–35.
- Prescott SL, Macaubas C, Smallacombe TB, Holt BJ, Sly PD, Holt PG. Development of allergen-specific T cell memory in atopic and normal children. *Lancet* 1999;353:196–200.
- Tang ML, Kemp AS, Thorburn J, Hill DJ. Reduced interferon-gamma secretion in neonates and subsequent atopy. *Lancet* 1994;344:983–5.
- Sicherer SH, Wood RA, Stablein D, Burks AW, Liu AH, Jones SM, et al. Immunologic features of infants with milk or egg allergy enrolled in an observational study (Consortium of Food Allergy Research) of food allergy. *J Allergy Clin Immunol* 2010;125:1077–1083.e8.
- McLoughlin RM, Calatroni A, Visness CM, Wallace PK, Cruikshank WW, Tuzova M, et al. Longitudinal relationship of early life immunomodulatory T cell phenotype and function to development of allergic sensitization in an urban cohort. *Clin Exp Allergy* 2012;42:392–404.
- Renzi PM, Turgeon JP, Marcotte JE, Drblik SP, Bérubé D, Gagnon ME, et al. Reduced interferon- $\gamma$  production in infants with bronchiolitis and asthma. *Am J Respir Crit Care Med* 1999;159:1417–22.
- Yunginger JW, Reed CE, O'Connell EJ, Melton LJ 3rd, O'Fallon WM, Silverstein MD. A community-based study of the epidemiology of asthma: incidence rates, 1964–1983. *Am Rev Respir Dis* 1992;146:888–94.
- Martinez FD, Wright AL, Taussig LM, Holberg CJ, Halonen M, Morgan WJ. Asthma and wheezing in the first six years of life. *N Engl J Med* 1995;332:133–8.
- Morgan WJ, Stern DA, Sherrill DL, Guerra S, Holberg CJ, Guilbert TW, et al. Outcome of asthma and wheezing in the first 6 years of life: follow-up through adolescence. *Am J Respir Crit Care Med* 2005;72:1253–8.
- Palmer LJ, Rye PJ, Gibson NA, Burton PR, Landau LI, Lesouëf PN. Airway responsiveness in early infancy predicts asthma, lung function, and respiratory symptoms by school age. *Am J Respir Crit Care Med* 2001;163:37–42.
- Stern DA, Morgan WJ, Halonen M, Wright AL, Martinez FD. Wheezing and bronchial hyperresponsiveness in early childhood as predictors of newly diagnosed asthma in early adulthood: a longitudinal birth-cohort study. *Lancet* 2008;372:1058–64.
- Horak E, Lanigan A, Roberts M, Welsh L, Wilson J, Carlin JB, et al. Longitudinal study of childhood wheezy bronchitis and asthma: outcome at age 42. *Br Med J* 2003;326:422–3.
- Godden DJ, Ross S, Abdalla M, McMurray D, Douglas A, Oldman D, et al. Outcome of wheeze in childhood. *Am J Respir Crit Care Med* 1994;149:106–12.
- Jenkins MA, Hopper JL, Bowes G, Carlin JB, Flander LB, Giles GG. Factors in childhood as predictors of asthma in adult life. *Br Med J* 1994;309:90–3.
- Strachan DP, Butland BK, Anderson HR. Incidence and prognosis of asthma and wheezing illness from early childhood to age 33 in a national British cohort. *Br Med J* 1996;312:1195–9.
- Sears MR, Greene JM, Willan AR, Wiecek EM, Taylor DR, Flannery EM, et al. A longitudinal, population-based, cohort study of childhood asthma followed to adulthood. *N Engl J Med* 2003;349:1414–22.
- Oswald H, Phelan PD, Lanigan A, Hibbert M, Carlin JB, Bowes G, et al. Childhood asthma and lung function in mid-adult life. *Pediatr Pulmonol* 1997;23:14–20.
- Stern DA, Morgan WJ, Wright AL, Guerra S, Martinez FD. Poor airway function in early infancy and lung function by age 22 years: a non-selective longitudinal cohort study. *Lancet* 2007;370:758–64.
- Covar RA, Spahn JD, Murphy JR, Szefer SJ, Childhood Asthma Management Program Research Group. Progression of asthma measured by lung function in the childhood asthma management program. *Am J Respir Crit Care Med* 2004;170:234–41.
- Castro-Rodriguez JA, Holberg CJ, Wright AL, Martinez FD. A clinical index to define risk of asthma in young children with recurrent wheezing. *Am J Respir Crit Care Med* 2000;162:1403–6.
- Kulig M, Bergmann R, Tacke U, Wahn U, Guggenmoos-Holzmann I. Long-lasting sensitization to food during the first two years precedes allergic airway disease: the MAS Study Group, Germany. *Pediatr Allergy Immunol* 1998;9:61–7.
- Lau S, Illi S, Sommerfeld C, Niggemann B, Bergmann R, von Mutius E, et al. Early exposure to house-dust mite and cat allergens and development of childhood asthma: a cohort study – Multicentre Allergy Study Group. *Lancet* 2000;356:1392–7.
- Illi S, von Mutius E, Lau S, Niggemann B, Grüber C, Wahn U, et al. Perennial allergen sensitisation early in life and chronic asthma in children: a birth cohort study. *Lancet* 2006;368:763–70.
- Zeiger RS, Heller S. The development and prediction of atopy in high-risk children: follow-up at age seven years in a prospective randomized study of combined maternal and infant food allergen avoidance. *J Allergy Clin Immunol* 1995;95:1179–90.
- The Childhood Asthma Management Program Research Group. Long-term effects of budesonide or nedocromil in children with asthma. *N Engl J Med* 2000;343:1054–63.
- ISAAC Steering Committee. Worldwide variation in prevalence of symptoms of asthma, allergic rhinoconjunctivitis, and atopic eczema: ISAAC. *Lancet* 1998;351:1225–32.
- Guilbert TW, Morgan WJ, Zeiger RS, Bacharier LB, Boehmer SJ, Krawiec M, et al. Atopic characteristics of children with recurrent wheezing at high risk for the development of childhood asthma. *J Allergy Clin Immunol* 2004;114:1282–7.
- National Institutes of Health, National Heart, Lung, and Blood Institute, National Asthma Education and Prevention Program. Expert Panel Report 3: Guidelines for the Diagnosis and Management of Asthma 2007;(NIH Publication No. 07–4051), p. 1–417.
- Taussig LM. Maximal expiratory flows at functional residual capacity: a test of lung function for young children. *Am Rev Respir Dis* 1977;116:1031–7.
- Tepper RS, Morgan WJ, Cota K, Wright A, Taussig LM. Physiologic growth and development of the lung during the first year of life. *Am Rev Respir Dis* 1986;134:513–19.
- Peat JK, Salome CM, Xuan W. On adjusting measurements of airway responsiveness for lung size and airway caliber. *Am J Respir Crit Care Med* 1996;154:870–5.
- Sears MR, Burrows B, Flannery EM, Herbison GP, Holdaway MD. Atopy in childhood. I. Gender and allergen-related risks for development of hay fever and asthma. *Clin Exp Allergy* 1993;23:941–8.
- Castro-Rodriguez JA, Holberg CJ, Morgan WJ, Wright AL, Martinez FD. Increased incidence of asthma-like symptoms in girls who become overweight or obese during the school years. *Am J Respir Crit Care Med* 2001;163:1344–9.
- Camilli AE, Holberg CJ, Wright AL, Taussig LM. Parental childhood respiratory illness and respiratory illness in their infants: Group Health Medical Associates. *Pediatr Pulmonol* 1993;16:275–80.
- Dezateux C, Stocks J, Dundas I, Fletcher ME. Impaired airway function and wheezing in infancy. *Am J Respir Crit Care Med* 1999;159:403–10.
- Christie GL, Helms PJ, Godden DJ, Ross SJ, Friend JA, Legge JS, et al. Asthma, wheezy bronchitis, and atopy across two generations. *Am J Respir Crit Care Med* 1999;159:125–9.



45. Wahn U. Review Series VI: the immunology of fetuses and infants: what drives the allergic march? *Allergy* 2000;55:591–9.
46. Sigurs N, Gustafsson PM, Bjarnason R, Lundberg F, Schmidt S, Sigurbergsson F, et al. Severe respiratory syncytial virus bronchiolitis in infancy and asthma and allergy at age 13. *Am J Respir Crit Care Med* 2005;171:137–41.
47. Stein RT, Sherrill D, Morgan WJ, Holberg CJ, Halonen M, Taussig LM, et al. Respiratory syncytial virus in early life and risk of wheeze and allergy by age 13 years. *Lancet* 1999;354:541–5.
48. Castro-Rodriguez JA, Holberg CJ, Wright AL, Halonen M, Taussig LM, Morgan WJ, et al. Association of radiologically ascertained pneumonia before age 3 yr with asthma-like symptoms and pulmonary function during childhood: a prospective study. *Am J Respir Crit Care Med* 1999;159:1891–7.
49. Castro-Rodriguez JA, Holberg CJ, Morgan WJ, Wright AL, Halonen M, Taussig LM, et al. Relation of two different subtypes of croup before age three to wheezing atopy, and pulmonary function during childhood: a prospective study. *Pediatrics* 2001;107:512–18.
50. Rakes GP, Arruda E, Ingram JM, Hoover GE, Zambrano JC, Hayden FG, et al. Rhinovirus and respiratory syncytial virus in wheezing children requiring emergency care: IgE and eosinophil analyses. *Am J Respir Crit Care Med* 1999;159:785–90.
51. Johnston NW, Johnston SL, Duncan JM, Greene JM, Kebabdzic T, Keith PK, et al. The September epidemic of asthma exacerbations in children: a search for etiology. *J Allergy Clin Immunol* 2005;115:132–8.
52. Lemanske RF Jr, Jackson DJ, Gangnon RE, Evans MD, Li Z, Shult PA, et al. Rhinovirus illnesses during infancy predict subsequent childhood wheezing. *J Allergy Clin Immunol* 2005;116:571–7.
53. Corne JM, Marshall C, Smith S, Schreiber J, Sanderson G, Holgate ST, et al. Frequency, severity, and duration of rhinovirus infections in asthmatic and non-asthmatic individuals: a longitudinal cohort study. *Lancet* 2002;359:831–4.
54. Jackson DJ, Gangnon RE, Evans MD, Roberg KA, Anderson EL, Pappas TE, et al. Wheezing rhinovirus illnesses in early life predict asthma development in high-risk children. *Am J Respir Crit Care Med* 2008;178:667–72.
55. Stein RT, Holberg CJ, Sherrill D, Wright AL, Morgan WJ, Taussig L, et al. Influence of parental smoking on respiratory symptoms during the first decade of life: the Tucson Children's Respiratory Study. *Am J Epidemiol* 1999;149:1030–7.
56. Hanrahan JP, Tager IB, Segal MR, Tosteson TD, Castile RG, Van Vunakis H, et al. The effect of maternal smoking during pregnancy on early infant lung function. *Am Rev Respir Dis* 1992;145:1129–35.
57. Kulig M, Luck W, Lau S, Niggemann B, Bergmann R, Klettke U, et al. Effect of pre- and postnatal tobacco smoke exposure on specific sensitization to food and inhalant allergens during the first 3 years of life. Multi-center Allergy Study Group, Germany. *Allergy* 1999;54:220–8.
58. Barbee RA, Halonen M, Kaltenborn W, Lebowitz M, Burrows B. A longitudinal study of serum IgE in a community cohort: correlations with age, sex, smoking, and atopic status. *J Allergy Clin Immunol* 1987;79:919–27.
59. Sherrill DL, Halonen M, Burrows B. Relationships between total serum IgE, atopy, and smoking: a twenty-year follow-up analysis. *J Allergy Clin Immunol* 1994;94:954–62.
60. Gdalevich M, Mimouni D, David M, Mimouni M. Breast-feeding and the onset of atopic dermatitis in childhood: a systematic review and meta-analysis of prospective studies. *J Am Acad Dermatol* 2001;45:520–7.
61. Gdalevich M, Mimouni D, Mimouni M. Breast-feeding and the risk of bronchial asthma in childhood: a systematic review with meta-analysis of prospective studies. *J Pediatr* 2001;139:261–6.
62. Liu AH. Hygiene hypothesis for allergy and asthma. In: Martin RJ, Sutherland ER, editors. *Lung biology in health and disease (series)*. New York: Informa Healthcare USA Inc; 2010. p. 32–59.
63. Ball TM, Castro-Rodriguez JA, Griffith KA, Holberg CJ, Martinez FD, Wright AL. Siblings, day-care attendance, and the risk of asthma and wheezing during childhood. *N Engl J Med* 2000;343:538–43.
64. Illi S, von Mutius E, Lau S, Bergmann R, Niggemann B, Sommerfeld C, et al. Early childhood infectious diseases and the development of asthma up to school age: a birth cohort study. *BMJ* 2001;322:390–5.
65. Gehring U, Bolte G, Borte M, Bischof W, Fahlbusch B, Wichmann HE, et al. Exposure to endotoxin decreases the risk of atopic eczema in infancy: a cohort study. *J Allergy Clin Immunol* 2001;108:847–54.
66. Phipatanakul W, Celedon JC, Raby BA, Litonjua AA, Milton DK, Sredl D, et al. Endotoxin exposure and eczema in the first year of life. *Pediatrics* 2004;114:13–18.
67. Perzanowski MS, Miller RL, Thorne PS, Barr RG, Divjan A, Sheares BJ, et al. Endotoxin in inner-city homes: associations with wheeze and eczema in early childhood. *J Allergy Clin Immunol* 2006;117:1082–9.
68. Gereda JE, Leung DYM, Thatayatikom A, Streib JE, Price MR, Klinnert MD, et al. Relation between house-dust endotoxin exposure, type 1 T cell development, and allergen sensitization in infants at high risk of asthma. *Lancet* 2000;355:1680–3.
69. Celedon JC, Milton DK, Ramsey CD, Litonjua AA, Ryan L, Platts-Mills TA, et al. Exposure to dust mite allergen and endotoxin in early life and asthma and atopy in childhood. *J Allergy Clin Immunol* 2007;120:144–9.
70. Gehring U, Bischof W, Fahlbusch B, Wichmann HE, Heinrich J. House dust endotoxin and allergic sensitization in children. *Am J Respir Crit Care Med* 2002;166:939–44.
71. Gehring U, Heinrich J, Hoek G, Giovannangelo M, Nordling E, Bellander T, et al. Bacteria and mould components in house dust and children's allergic sensitisation. *Eur Respir J* 2007;29:1144–53.
72. Braun-Fahrlander C, Riedler J, Herz U, Eder W, Waser M, Grize L, et al. Environmental exposure to endotoxin and its relation to asthma in school-age children. *N Engl J Med* 2002;347:869–77.
73. Douwes J, Siebers R, Wouters I, Doekes G, Fitzharris P, Crane J. Endotoxin, (1 → 3)-beta-D-glucans and fungal extra-cellular polysaccharides in New Zealand homes: a pilot study. *Ann Agric Environ Med* 2006;13:361–5.
74. Roponen M, Hyvarinen A, Hirvonen M-R, Keski-Nisula L, Pekkanen J. Change in IFN- $\gamma$ -producing capacity in early life and exposure of environmental microbes. *J Allergy Clin Immunol* 2005;116:1048–52.
75. Bufford JD, Reardon CL, Li Z, Roberg KA, DaSilva D, Eggleston PA, et al. Effects of dog ownership in early childhood on immune development and atopic diseases. *Clin Exp Allergy* 2008;38:1635–43.
76. Park JH, Gold DR, Spiegelman DL, Burge HA, Milton DK. House dust endotoxin and wheeze in the first year of life. *Am J Respir Crit Care Med* 2001;163:322–8.
77. Bjorksten B, Sepp E, Julge K, Voor T, Mikelsaar M. Allergy development and the intestinal microflora during the first year of life. *J Allergy Clin Immunol* 2001;108:516–20.
78. Kalliomaki M, Kirjavainen P, Eerola E, Kero P, Salminen S, Isolauri E. Distinct patterns of neonatal gut microflora in infants in whom atopy was and was not developing. *J Allergy Clin Immunol* 2001;107:129–34.
79. Bjorksten B, Naaber P, Sepp E, Mikelsaar M. The intestinal microflora in allergic Estonian and Swedish 2-year old children. *Clin Exp Allergy* 1999;29:342–6.
80. Sjogren YM, Jenmalm MC, Bottcher MF, Bjorksten B, Sverremark-Ekstrom E. Altered early infant gut microbiota in children developing allergy up to 5 years of age. *Clin Exp Allergy* 2009;39:518–26.
81. Wang M, Karlsson C, Olsson C, Adlerberth I, Wold AE, Strachan DP, et al. Reduced diversity in the early fecal microbiota of infants with atopic eczema. *J Allergy Clin Immunol* 2008;121:129–34.
82. Ege MJ, Mayer M, Normand AC, Genuneit J, Cookson WO, Braun-Fahrlander C, et al. Exposure to environmental microorganisms and childhood asthma. *N Engl J Med* 2011;364:701–9.
83. Lynch SV, Wood RA, Boushey H, Bacharier LB, Bloomberg GR, Kattan M, et al. Effects of early-life exposure to allergens and bacteria on recurrent wheeze and atopy in urban children. *J Allergy Clin Immunol* 2014;134:593–601.e12.
84. Bisgaard H, Hermansen MN, Buchvald F, Loland L, Halkjaer LB, Bonnelykke K, et al. Childhood asthma after bacterial colonization of the airway in neonates. *N Engl J Med* 2007;357:1487–95.
85. Kloefer KM, Lee WM, Pappas TE, Kang TJ, Vrtis RF, Evans MD, et al. Detection of pathogenic bacteria during rhinovirus infection is associated with increased respiratory symptoms and asthma exacerbations. *J Allergy Clin Immunol* 2014;133:1301–7, 1307.e1–3.
86. Remes ST, Castro-Rodriguez JA, Holberg CJ, Martinez FD, Wright AL. Dog exposure in infancy decreases the subsequent risk of frequent wheeze but not of atopy. *J Allergy Clin Immunol* 2001;108:509–15.
87. Ownby DR, Johnson CC, Peterson EL. Exposure to dogs and cats in the first year of life and risk of allergic sensitization at 6 to 7 years of age. *JAMA* 2002;288:963–72.
88. Gern JE, Reardon CL, Hoffman S, Nicolae D, Li Z, Roberg KA, et al. Effects of dog ownership and genotype on immune development and atopy in infancy. *J Allergy Clin Immunol* 2004;113:307–14.

89. Liu AH. Endotoxin exposure in allergy and asthma: reconciling a paradox. *J Allergy Clin Immunol* 2002;109:379–92.
90. Tse K, Horner AA. Defining a role for ambient TLR ligand exposures in the genesis and prevention of allergic disease. *Semin Immunopathol* 2008;30:53–62.
91. Takkouche B, Gonz ales-Barcala F-J, Etminan M, Fitzgerald M. Exposure to furry pets and the risk of asthma and allergic rhinitis: a meta-analysis. *Allergy* 2008;63:857–64.
92. Fujimura KE, Johnson CC, Ownby DR, Cox MJ, Brodie EL, Havstad SL, et al. Man's best friend? The effect of pet ownership on house dust microbial communities. *J Allergy Clin Immunol* 2010;126:410–12, 412.e1–3.
93. Litonjua AA. Childhood asthma may be a consequence of vitamin D deficiency. *Curr Opin Allergy Clin Immunol* 2009;9:202–7.
94. Litonjua AA, Weiss ST. Is vitamin D deficiency to blame for the asthma epidemic? *J Allergy Clin Immunol* 2007;120:1031–5.
95. Camargo CA Jr, Rifas-Shiman SL, Litonjua AA, Rich-Edwards JW, Weiss ST, Gold DR, et al. Maternal intake of vitamin D during pregnancy and risk of recurrent wheeze in children at 3 y of age. *Am J Clin Nutr* 2007;85:788–95.
96. Devereux G, Litonjua AA, Turner SW, Craig LC, McNeill G, Martindale S, et al. Maternal vitamin D intake during pregnancy and early childhood wheezing. *Am J Clin Nutr* 2007;85:853–9.
97. Erkkola M, Kaila M, Nwaru BI, Kronberg-Kippil a C, Ahonen S, Nevalainen J, et al. Maternal vitamin D intake during pregnancy is inversely associated with asthma and allergic rhinitis in 5-year-old children. *Clin Exp Allergy* 2009;39:875–82.
98. Howrylak JA, Fuhlbrigge AL, Strunk RC, Zeiger RS, Weiss ST, Raby BA. Classification of childhood asthma phenotypes and long-term clinical responses to inhaled anti-inflammatory medications. *J Allergy Clin Immunol* 2014;133:1289–300, 1300.e1–12.
99. Fitzpatrick AM, Teague WG, Meyers DA, Peters SP, Li X, Li H, et al. Heterogeneity of severe asthma in childhood: confirmation by cluster analysis of children in the National Institutes of Health/National Heart, Lung, and Blood Institute Severe Asthma Research Program. *J Allergy Clin Immunol* 2011;127:382–9, e1–13.
100. Woodruff PG, Modrek B, Choy DF, Jia G, Abbas AR, Ellwanger A, et al. T-helper type 2-driven inflammation defines major subphenotypes of asthma. *Am J Respir Crit Care Med* 2009;180:388–95.
101. Bergmann RL, Bergmann KE, Lau-Schadendorf S, Luck W, Dannemann A, Bauer CP, et al. Atopic diseases in infancy: the German multicenter atopy study (MAS-90). *Pediatr Allergy Immunol* 1994;5:19–25.
102. Hanifin JM, Rajka G. Diagnostic features of atopic dermatitis. *Acta Dermatol Venereol (suppl)* 1980;92:44–7.
103. Williams HC, Strachan DP. The natural history of childhood eczema: observations from the British 1958 cohort study. *Br J Dermatol* 1998;139:834–9.
104. Linna O. Ten-year prognosis for generalized infantile eczema. *Acta Paediatr* 1992;81:1013.
105. Vickers CFH. The natural history of atopic eczema. *Acta Dermatol Venereol* 1980;92:113–15.
106. Schultz Larsen F. Atopic dermatitis: a genetic-epidemiologic study in a population-based twin sample. *J Am Acad Dermatol* 1993;28:719–23.
107. Harris JM, Cullinan P, Williams HC, Mills P, Moffat S, White C, et al. Environmental associations with eczema in early life. *Br J Dermatol* 2001;144:795–802.
108. Lammintausta K. Prognosis of atopic dermatitis: a prospective study in early adulthood. *Int J Dermatol* 1991;30:563–8.
109. Guillet G, Guillet MH. Natural history of sensitizations in atopic dermatitis. *Arch Dermatol* 1992;128:187–92.
110. Patrizi A, Guerrini V, Ricci G, Neri I, Specchia F, Masi M. The natural history of sensitizations to food and aeroallergens in atopic dermatitis: a 4-year follow-up. *Pediatr Dermatol* 2000;17:261–5.
111. Bergmann RL, Edenharter G, Bergmann KE, Forster J, Bauer CP, Wahn V, et al. Atopic dermatitis in early infancy predicts allergic airway disease at 5 years. *Clin Exp Allergy* 1998;28:965–70.
112. Kulig M, Klettke U, Wahn V, Forster J, Bauer CP, Wahn U. Development of seasonal allergic rhinitis during the first 7 years of life. *J Allergy Clin Immunol* 2000;106:832–9.
113. Broder I. Epidemiology of asthma and allergic rhinitis in a total community, Tecumseh, Michigan. IV. Natural history. *J Allergy Clin Immunol* 1974;54:100.
114. Bock SA. Prospective appraisal of complaints of adverse reactions to foods in children during the first 3 years of life. *Pediatrics* 1987;79:683–8.
115. Zeiger RS, Heller S, Mellon MH, Forsythe AB, O'Connor RD, Hamburger RN, et al. Effect of combined maternal and infant food-allergen avoidance on development of atopy in early infancy: a randomized study. *J Allergy Clin Immunol* 1989;84:72–89.
116. Host A. Cow's milk protein allergy and intolerance in infancy: some clinical, epidemiological and immunological aspects. *Pediatr Allergy Immunol* 1994;5:1–36.
117. Bock SA. The natural history of food sensitivity. *J Allergy Clin Immunol* 1982;69:173–7.
118. Sampson HA, Scanlon SM. Natural history of food hypersensitivity in children with atopic dermatitis. *J Pediatr* 1989;115:23–7.
119. Spergel JM, Beausoleil JL, Pawlowski NA. Resolution of childhood peanut allergy. *Ann Allergy Asthma Immunol* 2000;85:435–7.
120. Vander Leek TK, Liu AH, Stefanski K, Blacker B, Bock SA. The natural history of peanut allergy in young children and its association with serum peanut-specific IgE. *J Pediatr* 2000;137:749–55.
121. Hill DJ, Bannister DG, Hosking CS, Kemp AS. Cow milk allergy within the spectrum of atopic disorders. *Clin Exp Allergy* 1994;24:1137–43.
122. Host A, Halken S. A prospective study of cow milk allergy in Danish infants during the first 3 years of life: clinical course in relation to clinical and immunological type of hypersensitivity reaction. *Allergy* 1990;45:587–96.
123. Cogswell JJ, Halliday DE, Alexander JR. Respiratory infections in the first year of life in children at risk of developing atopy. *Br Med J* 1982;284:1011–13.
124. Van Asperen PP, Kemp AS, Mellis CM. Skin test reactivity and clinical allergen sensitivity in infancy. *J Allergy Clin Immunol* 1984;73:381–6.
125. Webb LM, Lieberman P. Anaphylaxis: a review of 601 cases. *Ann Allergy Asthma Immunol* 2006;97:39–43.
126. Fernandez de Corres L, Moneo I, Munoz D, Bernaola G, Fern andez E, Audicana M, et al. Sensitization from chestnuts and bananas in patients with urticaria and anaphylaxis from contact with latex. *Ann Allergy* 1993;70:35–9.
127. Katayama H, Yamaguchi K, Kozuka T, Takashima T, Seez P, Matsuura K. Adverse reactions to ionic and nonionic contrast media: a report from the Japanese Committee on the Safety of Contrast Media. *Radiology* 1990;175:621–8.
128. Lieberman P, Patterson R, Metz R, Ukena G. Allergic reactions to insulin. *JAMA* 1971;215:1106–12.
129. Green GR, Rosenblum A. Report of the Penicillin Study Group – American Academy of Allergy. *J Allergy Clin Immunol* 1971;48:331–43.
130. Settapani GA, Klein DE, Boyd GK. Relationship of atopy and anaphylactic sensitization: a bee sting allergy model. *Clin Allergy* 1978;8:259–65.
131. Valentine MD, Schubert KC, Kagey-Sobotka A, Graft DF, Kwitrovich KA, Szlok M, et al. The value of immunotherapy with venom in children with allergy to insect stings. *N Engl J Med* 1990;323:1601–3.
132. Savliwala MN, Reisman RE. Studies of the natural history of stinging-insect allergy: long-term follow-up of patients without immunotherapy. *J Allergy Clin Immunol* 1987;80:741–5.
133. Franken HH, Dubois AE, Minkema HJ, van der Heide S, de Monchy JG. Lack of reproducibility of a single negative sting challenge response in the assessment of anaphylactic risk in patients with suspected yellow jacket hypersensitivity. *J Allergy Clin Immunol* 1994;93:431–6.
134. LeVan TD, Bloom JW, Bailey TJ, Karp CL, Halonen M, Martinez FD, et al. A common single nucleotide polymorphism in the CD14 promoter decreases the affinity of Sp protein binding and enhances transcriptional activity. *J Immunol* 2001;167:5838–44.
135. Baldini M, Lohman IC, Halonen M, Erickson RP, Holt PG, Martinez FD. A polymorphism\* in the 5' flanking region of the CD14 gene is associated with circulating soluble CD14 levels and with total serum immunoglobulin E. *Am J Respir Cell Mol Biol* 1999;20:976–83.
136. Koppelman GH, Reijmerink NE, Colin Stine O, Howard TD, Whittaker PA, Meyers DA, et al. Association of a promoter polymorphism of the CD14 gene and atopy. *Am J Respir Crit Care Med* 2001;163:965–9.
137. Litonjua AA, Belanger K, Celedon JC, Milton DK, Bracken MB, Kraft P, et al. Polymorphisms in the 5' region of the CD14 gene are associated with eczema in young children. *J Allergy Clin Immunol* 2005;115:1056–62.
138. Ober C, Tsalenko A, Parry R, Cox NJ. A second-generation genomewide screen for asthma-susceptibility alleles in a founder population. *Am J Hum Genet* 2000;67:1154–62.
139. Simpson A, John SL, Jury F, Niven R, Woodcock A, Ollier WE, et al. Endotoxin exposure, CD14, and allergic disease: an interaction between genes and the environment. *Am J Respir Crit Care Med* 2006;174:386–92.
140. Eder W, Klimecki W, Yu L, von Mutius E, Riedler J, Braun-Fahrlander C, et al. Opposite effects of CD 14/260 on serum IgE levels in

- children raised in different environments. *J Allergy Clin Immunol* 2005;116:601–7.
141. Gilliland FD, Li YF, Dubeau L, Berhane K, Avol E, McConnell R, et al. Effects of glutathione S-transferase M1, maternal smoking during pregnancy, and environmental tobacco smoke on asthma and wheezing in children. *Am J Respir Crit Care Med* 2002;166:457–63.
  142. Kabesch M, Hoefler C, Carr D, Leupold W, Weiland SK, von Mutius E. Glutathione S transferase deficiency and passive smoking increase childhood asthma. *Thorax* 2004;59:569–73.
  143. Breton CV, Vora H, Salam MT, Islam T, Wenten M, Gauderman WJ, et al. Variation in the GST mu locus and tobacco smoke exposure as determinants of childhood lung function. *Am J Respir Crit Care Med* 2009;179:601–7.
  144. Schroer KT, Biagini Myers JM, Ryan PH, LeMasters GK, Bernstein DI, Villareal M, et al. Associations between multiple environmental exposures and glutathione S-transferase P1 on persistent wheezing in a birth cohort. *J Pediatr* 2009;154:401–8.
  145. Bouzigon E, Corda E, Aschard H, Dizier MH, Boland A, Bousquet J, et al. Effect of 17q21 variants and smoking exposure in early-onset asthma. *N Engl J Med* 2008;359:1985–94.
  146. Koplin JJ, Osborne NJ, Wake M, Martin PE, Gurrin LC, Robinson MN, et al. Can early introduction of egg prevent egg allergy in infants? A population-based study. *J Allergy Clin Immunol* 2010;126:807–13.
  147. Du Toit G, Katz Y, Sasieni P, Mesher D, Maleki SJ, Fisher HR, et al. Early consumption of peanuts in infancy is associated with a low prevalence of peanut allergy. *J Allergy Clin Immunol* 2008;122:984–91.
  148. Du Toit G, Roberts G, Sayre PH, Plaut M, Bahnson HT, Mitchell H, et al. Identifying infants at high risk of peanut allergy: the Learning Early About Peanut Allergy (LEAP) screening study. *J Allergy Clin Immunol* 2013;131:135–43, e1–12.
  149. Woodcock A, Lowe LA, Murray CS, Simpson BM, Pipis SD, Kissen P, et al. Early life environmental control: effect on symptoms, sensitization, and lung function at age 3 years. *Am J Respir Crit Care Med* 2004;170:433–9.
  150. Arshad SH, Matthews S, Gant C, Hide DW. Effect of allergen avoidance on development of allergic disorders in infancy. *Lancet* 1992;339:1493–7.
  151. Hide DW, Matthews S, Matthews L, Stevens M, Ridout S, Twiselton R, et al. Effect of allergen avoidance in infancy on allergic manifestations at age two years. *J Allergy Clin Immunol* 1994;93:842–6.
  152. Hide DW, Matthews S, Tariq S, Arshad SH. Allergen avoidance in infancy and allergy at 4 years of age. *Allergy* 1996;51:89–93.
  153. Chan-Yeung M, Ferguson A, Watson W, Dimich-Ward H, Rousseau R, Lilley M, et al. The Canadian Childhood Asthma Primary Prevention Study: outcomes at 7 years of age. *J Allergy Clin Immunol* 2005;116:49–55.
  154. Maas T, Kaper J, Sheikh A, Knottnerus JA, Wesseling G, Dompeling E, et al. Mono and multifaceted inhalant and/or food allergen reduction interventions for preventing asthma in children at high risk of developing asthma. *Cochrane Database Syst Rev* 2009;3:CD006480.
  155. Arlian LG, Neal JS, Morgan MS, Vyszynski-Moher DL, Rapp CM, Alexander AK. Reducing relative humidity is a practical way to control dust mites and their allergens in homes in temperate climates. *J Allergy Clin Immunol* 2001;107:99–104.
  156. Boner AL, Niero E, Antolini I, Valletta EA, Gaburro D. Pulmonary function and bronchial hyperreactivity in asthmatic children with house dust mite allergy during prolonged stay in the Italian Alps (Misurina, 1756 m). *Ann Allergy* 1985;54:42–5.
  157. Grootendorst DC, Dahlen SE, Van Den Bos JW, Duiverman EJ, Veselic-Charvat M, Vrijlandt EJ, et al. Benefits of high-altitude allergen avoidance in atopic adolescents with moderate to severe asthma, over and above treatment with high-dose inhaled steroids. *Clin Exp Allergy* 2001;31:400–8.
  158. Murray AB, Ferguson AC. Dust-free bedrooms in the treatment of asthmatic children with house dust or house dust mite allergy: a controlled trial. *Pediatrics* 1983;71:418–22.
  159. ETAC Study Group. Allergic factors associated with the development of asthma and the influence of cetirizine in a double-blind, randomized, placebo-controlled trial: first results of ETAC. Early treatment of the atopic child. *Pediatr Allergy Immunol* 1998;9:116–24.
  160. Warner JO. A double-blinded, randomized, placebo-controlled trial of cetirizine in preventing the onset of asthma in children with atopic dermatitis: 18 months' treatment and 18 months' posttreatment follow-up. *J Allergy Clin Immunol* 2001;108:929–37.
  161. Bisgaard H, Hermansen MN, Loland L, Halkjaer LB, Buchvald F. Intermittent inhaled corticosteroids in infants with episodic wheezing. *N Engl J Med* 2006;354:1998–2005.
  162. Murray CS, Woodcock A, Langley SJ, Morris J, Custovic A, IFWIN Study Team. Secondary prevention of asthma by the use of Inhaled Fluticasone propionate in Wheezy Infants (IFWIN): double-blind, randomised, controlled study. *Lancet* 2006;368:754–62.
  163. Guilbert TW, Morgan WJ, Zeiger RS, Mauger DT, Boehmer SJ, Szefer SJ, et al. Long-term inhaled corticosteroids in preschool children at high risk for asthma. *N Engl J Med* 2006;354:1985–97.
  164. Castro-Rodriguez JA, Rodrigo GJ. Efficacy of inhaled corticosteroids in infants and preschoolers with recurrent wheezing and asthma: a systematic review with meta-analysis. *Pediatrics* 2009;123:e519–25.
  165. Moller C, Dreborg S, Ferdousi HA, Halken S, Høst A, Jacobsen L, et al. Pollen immunotherapy reduces the development of asthma in children with seasonal rhinoconjunctivitis (the PAT-study). *J Allergy Clin Immunol* 2002;109:251–6.
  166. Jacobsen L, Niggemann B, Dreborg S, Ferdousi HA, Halken S, Høst A, et al. Specific immunotherapy has long-term preventive effect of seasonal and perennial asthma: 10-year follow-up on the PAT study. *Allergy* 2007;62:943–8.
  167. Purello-D'Ambrosio F, Gangemi S, Merendino RA, Isola S, Puccinelli P, Parmiani S, et al. Prevention of new sensitizations in monosensitized subjects submitted to specific immunotherapy or not: a retrospective study. *Clin Exp Allergy* 2001;31:1295–302.
  168. Des Roches A, Paradis L, Menardo JL, Bouges S, Daurés JP, Bousquet J. Immunotherapy with a standardized Dermatophagoides pteronyssinus extract. VI. Specific immunotherapy prevents the onset of new sensitizations in children. *J Allergy Clin Immunol* 1997;99:450–3.
  169. Rautava S, Kalliomaki M, Isolauri E. Probiotics during pregnancy and breast-feeding might confer immunomodulatory protection against atopic disease in the infant. *J Allergy Clin Immunol* 2002;109:119–21.
  170. Pessi T, Sutas Y, Hurme M, Isolauri E. Interleukin-10 generation in atopic children following oral *Lactobacillus rhamnosus* GG. *Clin Exp Allergy* 2000;30:1804–8.
  171. Lee J, Seto D, Bielory L. Meta-analysis of clinical trials of probiotics for prevention and treatment of pediatric atopic dermatitis. *J Allergy Clin Immunol* 2008;121:116–121.e11.
  172. Hatakka K, Savilahti E, Ponka A, Meurman JH, Poussa T, Näse L, et al. Effect of long term consumption of probiotic milk on infections in children attending day care centers: double blind, randomized trial. *Br Med J* 2001;322:1–5.
  173. Kukkonen K, Savilahti E, Hahtela T, Juntunen-Backman K, Korpela R, Poussa T, et al. Long-term safety and impact on infection rates of postnatal probiotic and prebiotic (synbiotic) treatment: randomized, double-blind, placebo-controlled trial. *Pediatrics* 2008;122:8–12.
  174. Rautava S, Salminen S, Isolauri E. Specific probiotics in reducing the risk of acute infections in infancy: a randomised, double-blind, placebo-controlled study. *Br J Nutr* 2009;101:1722–6.
  175. Kuitunen M, Kukkonen K, Juntunen-Backman K, Korpela R, Poussa T, Tuure T, et al. Probiotics prevent IgE-associated allergy until age 5 years in cesarean-delivered children but not in the total cohort. *J Allergy Clin Immunol* 2009;123:335–41.



# The Genetics of Allergic Disease and Asthma

SAMUEL A. COLLINS | GABRIELLE A. LOCKETT | JOHN W. HOLLOWAY

## KEY POINTS

- Asthma and atopy are examples of complex genetic diseases that, despite a strong genetic component, do not exhibit simple Mendelian inheritance.
- The many genes involved have 'mild' mutations with small phenotypic effects that combine to influence disease phenotype.
- Numerous genes have been identified that are associated with asthma, atopy, atopic dermatitis and allergic rhinitis. Recent advances have largely been due to improvements in whole genome approaches.
- Research has now moved on to the modifying effects of environment on these genetic susceptibilities including the role of epigenetic changes.
- The hope is that we are now moving into an era of clinical application of these genetic findings such as the use of pharmacogenetics to tailor asthma treatment.

Since the first report of linkage between chromosome 11q13 and atopy in 1989,<sup>1</sup> there have been thousands of published studies of the genetics of asthma and other allergic diseases. Their aim is to identify the genetic factors that modify susceptibility to allergic diseases, determine severity of disease in affected individuals and affect the response to treatment. This recent expansion in our knowledge has provided intriguing insights into the pathophysiology of these complex disorders. In this chapter, we outline the approaches used to undertake genetic studies of common diseases such as atopic dermatitis and asthma and provide examples of how these approaches are beginning to reveal new insights into the pathophysiology of allergic diseases.

## Why Undertake Genetic Studies of Allergic Disease?

Susceptibility to allergic disease is likely to result from the inheritance of many gene variants but the underlying cellular defects are unknown. By undertaking research into the genetic basis of these conditions, these gene variants and their gene products can be identified solely by the anomalous phenotypes they produce. Identifying the genes that produce these disease phenotypes provides a greater understanding of the fundamental mechanisms of these disorders, stimulating the development of specific new drugs or biologics to both relieve and prevent

symptoms. In addition, genetic variants may also influence the response to therapy and the identification of individuals with altered response to current drug therapies will allow optimization of current therapeutic measures (i.e. disease stratification and pharmacogenetics). The study of genetic factors in large longitudinal cohorts with extensive phenotype and environmental information allows the identification of external factors that initiate and sustain allergic diseases in susceptible individuals and the periods of life in which this occurs, with a view to identifying those environmental factors that could be modified for disease prevention or for changing the natural history of the disorder. For example, early identification of vulnerable children would allow targeting of preventative therapy or environmental intervention, such as avoidance of allergen exposure. Genetic screening in early life may eventually become a practical and cost-effective option for allergic disease prevention.

## Approaches to Genetic Studies of Complex Genetic Diseases

### WHAT IS A COMPLEX GENETIC DISEASE?

The use of genetic analysis to identify genes responsible for simple Mendelian traits such as cystic fibrosis<sup>2</sup> has become almost routine in the 30 years since it was recognized that genetic inheritance can be traced with naturally occurring DNA sequence variation.<sup>3</sup> However, many of the most common medical conditions known to have a genetic component to their etiology, including diabetes, hypertension, heart disease, schizophrenia and asthma, have much more complex inheritance patterns.

Complex disorders show a clear hereditary component, however the mode of inheritance does not follow any simple Mendelian pattern. Furthermore, unlike single-gene disorders, they tend to have an extremely high prevalence. Asthma occurs in at least 10% of children in the UK, and atopy is as high as 40% in some population groups<sup>4</sup> as compared to cystic fibrosis at 1 in 2,000 live white births. Characteristic features of Mendelian diseases are that they are rare and involve mutations in a single gene that are 'severe', resulting in large phenotypic effects that may be independent of environmental influences. In contrast, complex disease traits are common and involve many genes, with 'mild' mutations leading to small phenotypic effects with strong environmental interactions.

### HOW TO IDENTIFY GENES UNDERLYING COMPLEX DISEASE

Before any genetic study of a complex disease can be initiated, there are a number of different factors that need to be



considered. These include: (1) assessing the heritability of a disease of interest to establish whether there is indeed a genetic component to the disease in question; (2) defining the phenotype (or physical characteristics) to be measured in a population; (3) the size and nature of the population to be studied; (4) determining which genetic markers are going to be typed in the DNA samples obtained from the population; (5) how the relationships between the genetic data and the phenotype measures in individuals are to be analyzed and (6) how the resulting data can be used to identify the genes underlying the disease.

One of the most important considerations in genetic studies of complex disease susceptibility is the choice of the methods of genetic analysis to be used. This choice will both reflect and be reflected in the design of the study. Will the study be a population study or a family-based study? What numbers of subjects will be needed?

### Inheritance

The first step in any genetic analysis of a complex disease is to determine whether genetic factors contribute at all to an individual's susceptibility to disease. The fact that a disease has been observed to 'run in families' may reflect common environmental exposures and biased ascertainment, as well as a potential true genetic component. There are a number of approaches that can be taken to determine if genetics contributes to a disease or disease phenotype of interest including family studies, segregation analysis, twin and adoption studies, heritability studies and population-based relative risk to relatives of probands.

There are three main steps involved in the identification of genetic mechanisms for a disease.<sup>5,6</sup>

1. Determine whether there is familial aggregation of the disease – does the disease occur more frequently in relatives of cases than of controls?
2. If there is evidence for familial aggregation, is this because of genetic effects or other factors such as environmental or cultural effects?
3. If there are genetic factors, which specific genetic mechanisms are operating?

The exact methods used in this process will vary depending on a number of disease-specific factors. For example, is the disease of early or late onset, and is the phenotype in question discrete or continuous (e.g. insulin resistance or blood pressure)?

Family studies involve the estimation of the frequency of the disease in relatives of affected, compared with unaffected, individuals. The strength of the genetic effect can be measured as  $\lambda_R$ , where  $\lambda_R$  is the ratio of risk to relatives of type R (sibs, parents, offspring, etc.) compared with the population risk ( $\lambda_R = \kappa_R/\kappa$ , where  $\kappa_R$  is the risk to relatives of type R and  $\kappa$  is the population risk). The stronger the genetic effect, the higher the value of  $\lambda$ . For example, for a recessive single-gene Mendelian disorder such as cystic fibrosis, the value of  $\lambda$  is about 500; for a dominant disorder such as Huntington's disease, it is about 5,000. For complex disorders the values of  $\lambda$  are much lower, e.g. 20–30 for multiple sclerosis, 15 for insulin-dependent diabetes mellitus (IDDM), and 4 to 5 for Alzheimer's disease. It is important to note, though, that  $\lambda$  is a function of both the strength of the genetic effect and the frequency of the disease in the population. Therefore, if a disease has a  $\lambda$  value of 3 to 4 it does not mean that genes are less important in that trait than in a trait with a  $\lambda$  of 30 to 40. A strong effect in a very common disease will have a smaller  $\lambda$  than the same strength of effect in a rare disease.

Determining the relative contribution of common genes versus common environment to clustering of disease within families can be undertaken using twin studies where the concordance of a trait in monozygotic and dizygotic twins is assessed. Monozygotic twins have identical genotypes, whereas dizygotic twins share, on average, only one half of their genes. In both cases, they share the same childhood environment. Therefore, a disease that has a genetic component is expected to show a higher rate of concordance in monozygotic than in dizygotic twins. Another approach used to disentangle the effects of nature versus nurture in a disease is in adoption studies, where, if the disease has a genetic basis, the frequency of the disease should be higher in biologic relatives of probands than in their adopted family.

Once familial aggregation with a probable genetic etiology for a disease has been established, the mode of inheritance can be determined by observing the pattern of inheritance of a disease or trait and how it is distributed within families. For example, is there evidence of a single major gene and is it dominantly or recessively inherited? Segregation analysis is the most established method for this purpose. The observed frequency of a trait in offspring and siblings is compared with the distribution expected with various modes of inheritance. If the distribution is significantly different than predicted, that model is rejected. The model that cannot be rejected is therefore considered the most likely. However, for complex disease, it is often difficult to undertake segregation analysis, because of the multiple genetic and environmental effects making any one model hard to determine. This has implications for the methods of analysis of genetic data in studies, because some methods, such as the parametric logarithm (base 10) of odds (LOD) score approach, require a model to be defined to obtain estimates of parameters such as gene frequency and penetrance (see Approaches to analysis).

### Phenotype

Studies of a genetic disorder require that a phenotype be defined, to which genetic data are compared. Phenotypes can be classified in two ways. They may be complex, such as asthma or atopy, and are likely to involve the interaction of a number of genes. Alternatively, intermediate phenotypes may be used, such as bronchial hyperresponsiveness (BHR) and eosinophilia for asthma and serum immunoglobulin E (IgE) levels and specific IgE responsiveness or positive skin prick tests to particular allergens for atopy. Together, these phenotypes contribute to an individual's expression of the overall complex disease phenotype but are likely to involve the interaction of fewer genetic influences, thus increasing the chances of identifying specific genetic factors predisposing toward the disease. Phenotypes may also be discrete or qualitative, such as the presence or absence of wheeze, atopy and asthma, or quantitative. Quantitative phenotypes, such as blood pressure (mm Hg), lung function measures (e.g. FEV<sub>1</sub>) and serum IgE levels, are phenotypes that can be measured as a continuous variable. With quantitative traits, no arbitrary cut-off point has to be assigned (making quantitative trait analysis important), because clinical criteria used to define an affected or an unaffected phenotype may not reflect whether an individual is a gene carrier or not. In addition, the use of quantitative phenotypes allows the use of alternative methods of genetic analysis that, in some situations, can be more powerful. Cluster analysis has been used to identify individual phenotypic expressions of asthma in a population sample.<sup>7,8</sup>

## Population

Having established that the disease or phenotype of interest does have a genetic component to its etiology, the next step is to recruit a study population in which to undertake genetic analyses to identify the gene(s) responsible. The type and size of study population recruited depend heavily on a number of interrelated factors, including the epidemiology of the disease, the method of genetic epidemiologic analysis being used, and the class of genetic markers genotyped. For example, the recruitment of families is necessary to undertake linkage analysis, whereas association studies are better suited to either a randomly selected or case-control cohort. In family-based linkage studies, the age of onset of a disease will determine whether it is practical to collect multigenerational families or affected sib pairs for analysis. Equally, if a disease is rare, then actively recruiting cases and matched controls will be a more practical approach compared to recruiting a random population that would need to be very large to have sufficient power.

## Genetic Markers

Genetic markers used can be any identifiable site within the genome (locus), where the DNA sequence is variable (polymorphic between individuals). The most common genetic markers used for linkage analysis are microsatellite markers comprising short lengths of DNA consisting of repeats of a specific sequence (e.g. CA<sub>n</sub>). The number of repeats varies between individuals, thus providing polymorphic markers that can be used in genetic analysis to follow the transmission of a chromosomal region from one generation to the next. Single-nucleotide polymorphisms (SNPs) are the simplest class of polymorphism in the genome resulting from a single base substitution: for example cytosine substituted for thymidine. SNPs are much more frequent than microsatellites in the human genome, occurring in introns, exons, promoters and intergenic regions, with several million SNPs now having been identified and mapped.<sup>9</sup> Another source of variation in the human genome that has recently been recognized to be present to a much greater extent than was previously thought is copy number variations (CNVs). CNVs are either a deletion or insertion of a large piece of DNA sequence; CNVs can contain whole genes and therefore are correlated with gene expression in a dose-dependent manner.<sup>10</sup> Sequencing of an individual human genome revealed that non-SNP variation (which includes CNVs) made up 22% of all variation in that individual but involved 74% of all variant DNA bases in that genome.<sup>11</sup>

## Approaches to Analysis

Linkage analysis involves proposing a model to explain the inheritance pattern of phenotypes and genotypes observed in a pedigree.<sup>12</sup> Linkage is evident when a gene that produces a phenotypic trait and its surrounding markers are co-inherited. In contrast, those markers not associated with the anomalous phenotype of interest will be randomly distributed among affected family members as a result of the independent assortment of chromosomes and crossing over during meiosis. In complex disease, non-parametric linkage approaches, such as allele sharing, are usually used. Allele-sharing methods test whether the inheritance pattern of a particular chromosomal region is not consistent with random Mendelian segregation by showing that pairs of affected relatives inherit identical copies

of the region more often than would be expected by chance.<sup>13</sup> While family-based analysis utilizing linkage analysis or allele-sharing methods was the mainstay of gene identification for monogenic diseases in the past, it has been largely superseded for analysis of common disease by the use of genome-wide association studies (for common variants) and next-generation sequencing of whole or partial (e.g. protein-coding fraction or exome) individual genomes.

Association studies do not examine inheritance patterns of alleles; rather, they are case-control studies based on a comparison of allele frequencies between groups of affected and unaffected individuals from a population. The odds ratio of the trait in individuals is then assessed as the ratio of the frequency of the allele in the affected population compared with the unaffected population. The greatest problem in association studies is the selection of a suitable control group to compare with the affected population group. Although association studies can be performed with any random DNA polymorphism, they have the most significance when applied to polymorphisms that have functional consequences in genes relevant to the trait (candidate genes).

It is important to remember with association studies that there are a number of reasons leading to an association between a phenotype and a particular allele:

- A positive association between the phenotype and the allele will occur if the allele is the cause of, or contributes to, the phenotype. This association would be expected to be replicated in other populations with the same phenotype, unless there are several different alleles at the same locus contributing to the same phenotype, in which case association would be difficult to detect, or if the trait was predominantly the result of different genes in the other population (genetic heterogeneity).
- Positive associations may also occur between an allele and a phenotype if that particular allele is in linkage disequilibrium (LD) with the phenotype-causing allele. That is, the allele tends to occur on the same parental chromosome that also carries the trait-causing mutation more often than would be expected by chance. Linkage disequilibrium will occur when most causes of the trait are the result of relatively few ancestral mutations at a trait-causing locus and the allele is present on one of those ancestral chromosomes and lies close enough to the trait-causing locus that the association between them has not been eroded away through recombination between chromosomes during meiosis. LD is the non-random association of adjacent polymorphisms on a single strand of DNA in a population; the allele of one polymorphism in an LD block (haplotype) can predict the allele of adjacent polymorphisms (one of which could be the causal variant).
- Positive association between an allele and a trait can also be artefactual as a result of recent population admixture. In a mixed population, any trait present in a higher frequency in a subgroup of the population (e.g. an ethnic group) will show positive association with an allele that also happens to be more common in that population subgroup.<sup>14</sup> Thus, to avoid spurious association arising through admixture, studies should be performed in large, relatively homogeneous populations. An alternative method to test for association in the presence of linkage is the 'transmission test for linkage disequilibrium'

(transmission/disequilibrium test [TDT]).<sup>15,16</sup> The TDT uses families with at least one affected child, and the transmission of the associated marker allele from a heterozygous parent to an affected offspring is evaluated. If a parent is heterozygous for an associated allele *A1* and a non-associated allele *A2*, then *A1* should be passed on to the affected child more often than *A2*.

Historically, association studies were not well suited to whole genome searches in large mixed populations. Because linkage disequilibrium extends over very short genetic distances in an old population, many more markers would need to be typed to 'cover' the whole genome. Therefore, genome-wide searches for association were more favorable in young, genetically isolated populations, because linkage disequilibrium extends over greater distances and the number of disease-causing alleles is likely to be fewer.

However, advances in array-based SNP genotyping technologies and haplotype mapping of the human genome<sup>17</sup> mean genome-wide association studies (GWAS) have revolutionized the study of genetic factors in complex common disease over the last decade.<sup>18,19</sup> For more than 150 phenotypes – from common diseases to physiological measurements such as height and BMI and biological measurements such as circulating lipid levels and blood eosinophil levels – GWAS have provided compelling statistical associations for thousands of different loci in the human genome<sup>20</sup> and are now the method of choice for identification of genetic variants influencing physiological or disease phenotypes.

### Identify Gene

If, as in most complex disorders, the exact biochemical or physiologic basis of the disease is unknown, there are three main approaches to finding the disease gene(s). One method is to test markers randomly spaced throughout the entire genome for linkage with the disease phenotype. If linkage is found between a particular marker and the phenotype, then further typing of genetic markers including SNPs and association analysis will enable the critical region to be further narrowed. The genes positioned in this region can be examined for possible involvement in the disease process and the presence of disease-causing mutations in affected individuals. This approach is often termed *positional cloning*, or *genome scanning* if the whole genome is examined in this manner. Although this approach requires no assumptions to be made as to the particular gene involved in genetic susceptibility to the disease in question, it does require considerable molecular genetic analysis to be undertaken in large family cohorts, involving considerable time, resource and expense.

As noted above, this approach has now been superseded by genome-wide association studies using SNPs evenly spaced throughout the genome as an assumption-free approach to locate disease-associated genes involved in disease pathogenesis. As GWAS utilize large data sets, up to one million SNPs to test for association, stringent genotype calling, quality control, population stratification (genomic controls) and statistical techniques have been developed to handle the analysis of such data.<sup>21</sup> Studies start by reporting single marker analyses of primary outcome; SNPs are considered to be strongly associated if the P-values are below the 1% false discovery rate (FDR) or showing weak association above 1% but below the 5% FDR. A cluster of P-values below the 1% FDR from SNPs in one chromosomal location is defined as the region of 'maximal

association' and is the first candidate gene region to examine further, with analysis of secondary outcome measures, gene database searches, fine mapping to find the causal locus and replication in other cohorts/populations. It is unlikely that the SNP showing the strongest association will be the causal locus, as SNPs are chosen to provide maximal coverage of variation in that region of the genome and not on biological function. Therefore, GWAS will often include fine mapping/haplotype analysis of the region with the aim of identifying the causal locus. If linkage disequilibrium prevents the identification of a specific gene in a haplotype block, then it may be necessary to utilize different racial and ethnic populations to hone in on the causative candidate gene that accounts for the genetic signal in GWAS.<sup>22</sup>

Finally, candidate genes can be selected for analysis because of a known role for the encoded product of the gene in the disease process. The gene is then screened for polymorphisms, which are tested for association with the disease or phenotype in question. A hybrid approach is the selection of candidate genes based not only on their function but also on their position within a genetic region previously linked to the disease (positional candidate). This approach may help to reduce the considerable work required to narrow a large genetic region of several megabases of DNA identified through linkage containing tens to hundreds of genes to one single gene to test for association with the disease.

Once a gene has been identified, further work is required to understand its role in the disease pathogenesis. Further molecular genetic studies may help to identify the precise genetic polymorphism that is having functional consequences for the gene's expression or function as opposed to those that are merely in linkage disequilibrium with the causal SNP. Often the gene identified may be completely novel and cell and molecular biology studies will be needed to understand the gene product's role in the disease and to define genotype/phenotype correlations. Furthermore, by using cohorts with information available on environmental exposures, it may be possible to define how the gene product may interact with the environment to cause disease. Ultimately, knowledge of the gene's role in disease pathogenesis may lead to the development of novel therapeutics.

## ALLERGY AND ASTHMA AS COMPLEX GENETIC DISEASES

From studies of the epidemiology and heritability of allergic diseases, it is clear that these are complex diseases in which the interaction between genetic and environmental factors plays a fundamental role in the development of IgE-mediated sensitivity and the subsequent development of clinical symptoms. The development of IgE responses by an individual, and therefore allergies, is the function of several genetic factors. These include the regulation of basal serum immunoglobulin production, the regulation of the switching of Ig-producing B cells to IgE, and the control of the specificity of responses to antigens. Furthermore, the genetic influences on allergic diseases such as asthma are more complex than those on atopy alone, involving not only genes controlling the induction and level of an IgE-mediated response to allergen but also 'lung-' or 'asthma'-specific genetic factors that result in the development of asthma. This also applies equally to other clinical manifestations of atopy such as rhinitis and atopic dermatitis.



## Phenotypes for Allergy and Allergic Disease: What Should We Measure?

The term *atopy* (from the Greek word for ‘strangeness’) was originally used by Coca and Cooke<sup>23</sup> in 1923 to describe a particular predisposition to develop hypersensitivity to common allergens associated with an increase of circulating reaginic antibody, now defined as IgE, and with clinical manifestations such as whealing-type reactions, asthma and hay fever. Today, even if the definition of *atopy* is not yet precise, the term is commonly used to define a disorder involving IgE antibody responses to ubiquitous allergens that is associated with a number of clinical disorders such as asthma, allergic dermatitis, allergic conjunctivitis and allergic rhinitis.

Atopy can be defined in several ways, including raised total serum IgE levels, the presence of antigen-specific IgE antibodies, and/or a positive skin test to common allergens. Furthermore, because of their complex clinical phenotype, atopic diseases can be studied using intermediate or surrogate disease-specific measurements such as BHR or lung function for asthma. As discussed earlier, phenotypes can be defined in several ways: subjective measures (e.g. symptoms), objective measures (e.g. BHR, blood eosinophils or serum IgE levels), or both. In addition, some studies have used quantitative scores that are derived from both physical measures such as serum IgE and BHR and questionnaire data.<sup>24,25</sup> It is a lack of a clear definition of atopic phenotypes that presents the greatest problem when reviewing studies of the genetic basis of atopy, with multiple definitions of the same intermediate phenotype often being used in different studies. Likewise, the definition of asthma can be problematic as this can be clinical (symptoms, parental reports), pharmacological (bronchodilator reversibility, steroid responsiveness) or derived from intermediate measures (BHR, lung function).

## The Heritability of Atopic Disease: Are Atopy and Atopic Disease Heritable Conditions?

In 1916, the first comprehensive study of the heritability of atopy was undertaken by Robert Cooke and Albert Vander Veer<sup>26</sup> at the Department of Medicine of the Postgraduate Hospital and Medical School of New York. Although the atopic conditions they included, as well as those excluded (e.g. eczema), may be open for debate today, the conclusions nonetheless remain the same: that there is a high heritable component to the development of atopy and atopic disease, and as is now more clearly understood biologically, this is owing to the inheritance of a tendency to generate specific IgE responses to common proteins.

Subsequent to the work of Cooke and Vander Veer, the results of many studies have established that atopy and atopic disease such as asthma, rhinitis and eczema have strong genetic components. Family studies have shown an increased prevalence of atopy, and phenotypes associated with atopy, among the relatives of atopic compared with non-atopic subjects.<sup>27–29</sup> In a study of 176 normal families, Gerrard and colleagues<sup>30</sup> found a striking association between asthma in the parent and asthma in the child, between hay fever in the parent and hay fever in the child, and between eczema in the parent and eczema in the child. These studies suggest that ‘end-organ sensitivity’,

or which allergic disease an allergic individual will develop, is controlled by specific genetic factors, differing from those that determine susceptibility to atopy per se. This hypothesis is borne out by a questionnaire study involving 6,665 families in southern Bavaria. Children with atopic diseases had a positive family history in 55% of cases compared with 35% in children without atopic disease ( $P < .001$ ).<sup>31</sup> Subsequent researchers used the same population to investigate familial influences unique to the expression of asthma and found that the prevalence of asthma alone (i.e. without hay fever or eczema) increased significantly if the nearest of kin had asthma alone (11.7% vs 4.7%,  $P < .0001$ ). A family history of eczema or hay fever (without asthma) was unrelated to asthma in the offspring.<sup>32</sup>

Numerous twin studies<sup>33–39</sup> have shown a significant increase in concordance for atopy among monozygotic twins compared with dizygotic twins, and both twin and family studies have shown a strong heritable component to atopic asthma.<sup>37,38,40–42</sup> Using a twin-family model, Laitinen and colleagues<sup>43</sup> reported that in families with asthma in successive generations, genetic factors alone accounted for as much as 87% of the development of asthma in offspring, and the incidence of the disease in twins with affected parents is 4-fold compared with the incidence in twins without affected parents. This indicates that asthma is recurring in families as a result of shared genes rather than shared environmental risk factors. This has been further substantiated in a study of 11,688 Danish twin pairs suggesting that 73% of susceptibility to asthma was the result of the genetic component. However, a substantial part of the variation in liability of asthma was the result of environmental factors; there also was no evidence for genetic dominance or shared environmental effects.<sup>44</sup>

## Molecular Regulation of Atopy and Atopic Disease, I: Susceptibility Genes

### POSITIONAL CLONING BY GENOME-WIDE SCREENS

Many genome-wide screens for atopy and atopic disorder susceptibility genes have been undertaken.<sup>45,46</sup> Multiple regions of the genome have been observed to be linked to varying phenotypes with differences between cohorts recruited from both similar and different populations. This illustrates the difficulty of identifying susceptibility genes for complex genetic diseases. Different genetic loci will show linkage in populations of different ethnicities and different environmental exposures. As mentioned earlier, in studies of complex disease, the real challenge has not been identification of regions of linkage, but rather identification of the precise gene and genetic variant underlying the observed linkage. To date, several genes have been identified as the result of positional cloning using a genome-wide scan for allergic disease phenotypes, including for example *ADAM33*, *GPRA*, *DPP10*, *PHF11* and *UPAR* for asthma, *COL29A1* for atopic dermatitis and *PCDH1* for bronchial hyperresponsiveness.

### GENES IDENTIFIED BY GENOME-WIDE ASSOCIATION STUDIES

Subsequent to positional cloning studies, improvements in technology have now enabled genome-wide association studies



to be performed with great success in allergic diseases such as asthma, eczema and allergic sensitization. Figure 3-1 illustrates allergy-associated genes reported in GWAS for asthma, rhinitis, serum IgE, atopy and atopic dermatitis, and the overlap between genes associated with different allergic diseases.

The first novel asthma susceptibility locus to be identified by a GWAS approach contains the *ORMDL3* and *GSDML* genes on chromosome 17q12-21.1.<sup>47</sup> 317,000 SNPs (in genes or surrounding sequences) were characterized in 994 subjects with childhood-onset asthma and 1,243 non-asthmatics followed by

replication in a further 2,320 subjects that revealed five significantly associated SNPs. Following gene expression studies, *ORMDL3* was found to be strongly associated with disease-associated markers ( $P < 10^{-22}$  for rs7216389) identified by the GWAS.

Importantly, a number of subsequent studies have replicated the association between variation in the chromosome 17q21 region (mainly rs7216389) and childhood asthma in ethnically diverse populations.<sup>48-51</sup> A GWAS by the GABRIEL consortium<sup>52</sup> of 26,475 people confirmed the association between

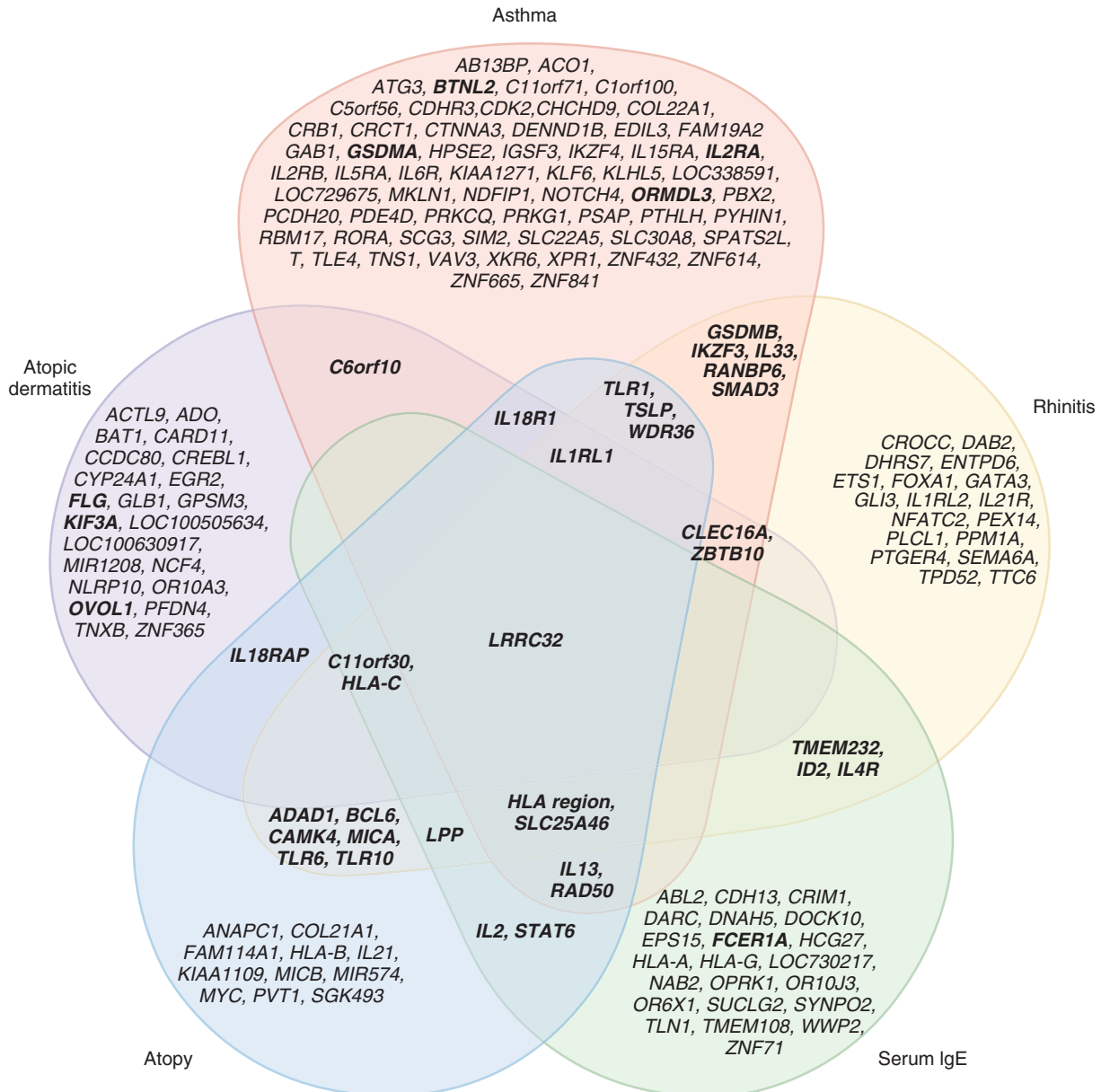

**Figure 3-1** Overlapping sets of genes have been reported in genome-wide association studies for asthma, rhinitis, serum IgE levels, atopy and atopic dermatitis, supporting a common genetic element within the mechanisms predisposing individuals toward different allergic disease phenotypes. GWAS have also identified many genes in association with only one allergic disease phenotype – these most likely represent the tissue-specific component of each allergic disease (e.g. *FLG* in the epidermal barrier in atopic dermatitis). To date, more GWAS have been conducted analyzing genetic variants associated with asthma than with other allergic diseases. In the future it is likely that more risk variants for other allergic diseases will be identified.

Genes reported in more than one GWAS are shown in bold font. The gene/s reported for SNPs detected to be significantly associated ( $P \leq 1 \times 10^{-5}$ ) with each allergic disease phenotype were obtained by searching the NHGRI GWAS catalog (<http://www.genome.gov/gwastudies>, accessed 4 August 2014).

*GSDML-ORMDL3* and childhood-onset asthma as well as implicating a number of genes involved in Th2 activation including *IL33*, *IL1RL1* and *SMAD*. The loci associated with asthma were not associated with serum IgE levels.

However, a study of association between SNPs and gene expression levels found that a distant SNP rs1051740 (greater than 4 megabases away and on a different chromosome) in the *EPHX1* gene associates with *ORMDL3* gene expression at a more significant level than rs7216389.<sup>53</sup> Long-distance genomic interactions can mean that the gene within which the SNP is located is not necessarily the causal gene.<sup>54,55</sup> Therefore, it is important to remember that considerable work is still required to fully characterize this region of the genome before accepting *ORMDL3* as the causal gene through 'guilt by association' because many genes in a region of linkage disequilibrium will be associated with disease in a GWAS without, necessarily, being the causative gene. GWAS have also identified novel genes underlying blood eosinophil levels (and also associated with asthma),<sup>56</sup> occupational asthma,<sup>57</sup> total serum IgE levels<sup>58</sup> and eczema.<sup>59</sup>

Studies of other atopic diseases have focussed on serum IgE levels and/or allergic sensitization. Weidinger et al identified a locus associated with the high-affinity IgE receptor (*FCERIA*) as strongly associated with both serum IgE and sensitization as well as confirming candidate gene findings of *STAT6* and the 5q31 region related to Th2 cytokines.<sup>58</sup> An Icelandic study showed an association between *IL1RL1* (the IL-33 receptor coding gene) and blood IgE levels.<sup>56</sup> This region was also identified in the asthma GWAS by Moffatt et al<sup>52</sup>; however that study did not find an association between asthma and loci associated with serum IgE levels. A meta-analysis of GWAS studies into allergic sensitization that included a total of 16,170 sensitized individuals, identified a total of 10 loci that are estimated to account for 25% of allergic sensitization and allergic rhinitis. Nine of the 10 SNPs identified also showed a directionally consistent association with asthma. Associations were also identified with atopic dermatitis, albeit weaker than with asthma. The authors also investigated known susceptibility loci and found only weak associations with total IgE levels (*FCERIA* and *HLA-A*) and asthma (17q12-21 and *IL33*). This suggests that these loci do not increase asthma risk through allergic sensitization.<sup>60</sup>

Until recently, very little was known of the genetic causes of atopic dermatitis (AD), aside from *filaggrin*, which is described in more detail below. However, recent studies have expanded this knowledge: a recent meta-analysis of atopic dermatitis studies by Paternoster et al on 11,025 cases and 40,398 controls revealed loci at *OVOL1* and *ACTL9* associated with epidermal proliferation and *KIF3A* in the 5q31 Th2 cytokine cluster. The study also confirmed the *filaggrin* (*FLG*) locus association.<sup>61</sup> Meanwhile, Weidinger et al studied childhood-onset AD and again identified the *FLG* association as well as the *KIF3A* locus mentioned above and the previously identified 11q13.5 and 5q31 regions. They also noted some overlap with asthma and psoriasis, strengthening the view that AD arises from both epithelial and immune dysfunction.<sup>62</sup> This theory is backed up by the discovery of an AD-associated SNP adjacent to *C11orf30*, which was previously identified as a Crohn's disease susceptibility locus, another disease of immune and epithelial dysfunction.<sup>59</sup> Sun et al identified *TMEM232* and *SLC25A46* at 5q22 and *TNFRSF6B* and *ZGPAT* at 20q13 in association with AD in Chinese populations.<sup>63</sup>

Atopic rhinitis is poorly understood but GWAS have identified loci in *C11orf30*,<sup>64</sup> mentioned above, as well as the HLA region, *MRPL4* and *BCAP*.<sup>65</sup> Candidate gene studies found an association with *IL13* loci,<sup>66</sup> and GWAS have identified several rhinitis-associated loci<sup>64</sup> and loci associated with the phenotype 'asthma and hay fever'.<sup>67</sup> Likewise, there is much overlap between food allergy and atopy with candidate gene studies showing associations with *CD14*, *STAT6*, *SPINK5* and *IL10*<sup>68</sup> but, to date, there have been no GWAS in food allergy.

These studies show the power of the GWAS approach for identifying complex disease susceptibility variants and current research is both expanding these known variants and confirming their associations with clinical phenotypes.<sup>69</sup> GWAS has now moved on from simple loci of association with a broad disease definition, such as asthma, and studies are now identifying particular regions associated with phenotypes of disease or subgroups. For example, Du et al identified *CRTAM* as associated only with asthma exacerbations in those with low vitamin D, and another recent GWAS has identified *CDHR3* as being associated with severe asthma.<sup>70</sup> We are also gaining a better understanding of how atopic and non-atopic asthma overlap with other atopic diseases such as atopic dermatitis<sup>61</sup> and rhinitis.<sup>71</sup> We may also be able to integrate epigenetic information into the expression patterns of known and novel SNPs, for example, asthma risk resulting from the *IL4R* polymorphism rs3024685 is dramatically increased by higher levels of *IL4R* DNA methylation.<sup>72</sup> Although GWAS has not fully explained the heritability of asthma and atopic disease, geneticists remain optimistic, as it is believed that this 'missing heritability' can be accounted for.<sup>73</sup> It is thought that the inability to find genes could be explained by limitations of GWAS, such as other variants not screened for, analyses not adjusted for gene-environment and gene-gene interactions or epigenetic changes in gene expression. One explanation for missing heritability, after assessing common genetic variation in the genome, is that rare variants (below the frequency of SNPs included in GWAS studies) of high genetic effect, or common copy number variants may be responsible for some of the genetic heritability of common complex diseases.<sup>9</sup>

## CANDIDATE GENE/GENE REGION STUDIES

A large number of candidate regions have been studied for both linkage to and association with a range of atopy-related phenotypes. In addition, SNPs in the promoter and coding regions of a wide range of candidate genes have been examined. Candidate genes are selected for analysis based on a wide range of evidence, for example biological function, differential expression in disease, involvement in other diseases with phenotypic overlap, affected tissues, cell type(s) involved and findings from animal models. There are now more than 500 studies that have examined polymorphism in more than 200 genes for association with asthma and allergy phenotypes.<sup>45,74</sup> When assessing the significance of association studies, it is important to consider several things. For example, was the size of the study adequately powered if negative results are reported? Were the cases and controls appropriately matched? Could population stratification account for the associations observed? In the definitions of the phenotypes, which phenotypes have been measured (and which have not)? How were they measured? Regarding correction for multiple testing, have the authors taken multiple testing into account when assessing the

significance of association? Publications by Weiss,<sup>75</sup> Hall,<sup>76</sup> and Tabor and colleagues<sup>77</sup> review these issues in depth.

Genetic variants showing association with a disease are not necessarily causal, because of the phenomenon of linkage disequilibrium (LD), whereby polymorphism A is not affecting gene function but rather it is merely in LD with polymorphism B that is exerting an effect on gene function or expression. Positive association may also represent a Type I error; candidate gene studies have suffered from non-replication of findings between studies, which may be due to poor study design, population stratification, different LD patterns between individuals of different ethnicity and differing environmental exposures between study cohorts. The genetic association approach can also be limited by under-powered studies and loose phenotype definitions.<sup>78</sup>

### An Example of a Candidate Gene: Interleukin-13

Given the importance of Th2-mediated inflammation in allergic disease, and the biological roles of *IL13*, including switching B cells to produce IgE, wide-ranging effects on epithelial cells, fibroblasts, and smooth muscle promoting airway remodeling and mucus production, *IL13* is a strong biological candidate gene. Furthermore, *IL13* is also a strong positional candidate. The gene encoding *IL13*, like *IL4*, is located in the Th2 cytokine gene cluster on chromosome 5q31 within 12 kb of *IL4*,<sup>79</sup> with which it shares 40% homology. This genomic location has been extensively linked with a number of phenotypes relevant to allergic disease including asthma, atopy, specific and total IgE responses, blood eosinophils and BHR.<sup>80</sup>

Asthma-associated polymorphisms have been identified in the *IL13* gene, including a single-base pair substitution in the promoter of *IL13* adjacent to a consensus nuclear factor of activated T cell binding sites. Asthmatics are significantly more likely to be homozygous for this polymorphism ( $P = .002$ , odds ratio = 8.3)<sup>81</sup> and the polymorphism is associated, in vitro, with reduced inhibition of *IL13* production by cyclosporine and increased transcription factor binding. Hypotheses proposed to explain the association of this *IL13* polymorphism and development of atopic disease include decreased affinity for the decoy receptor *IL13R $\alpha$ 2*, increased functional activity through *IL13R $\alpha$ 1* and enhanced stability of the molecule in plasma (reviewed in Kasaian and Miller<sup>82</sup>).

An amino acid polymorphism of *IL13* has also been described: R110Q (rs20541).<sup>83–85</sup> The 110Q variant enhances allergic inflammation compared to the 110R wild-type *IL-13*<sup>86</sup> by inducing STAT6 phosphorylation, CD23 expression in monocytes and hydrocortisone-dependent IgE switching in B cells. It also has a lower affinity for the *IL-13R $\alpha$ 2* decoy receptor and produced a more sustained eotaxin response in primary human fibroblasts expressing low levels of *IL-13R $\alpha$ 2*.<sup>87</sup>

*IL-13* polymorphism associations have been inconsistent with some studies showing association with atopy in children<sup>85,88</sup> while others show associations with asthma and not atopy.<sup>86</sup> Howard and colleagues<sup>89</sup> also showed that the –1112 C/T variant of *IL13* contributes significantly to BHR susceptibility ( $P = .003$ ) but not to total serum IgE levels. Thus, it is possible that polymorphisms in *IL13* may confer susceptibility to airway remodeling in persistent asthma, as well as to allergic inflammation in early life.

As discussed previously, positive association observed between an SNP and a phenotype does not imply that the SNP is causal. *IL13* lies adjacent to *IL4*, an equally strong biological

candidate in which SNPs have shown association with relevant phenotypes,<sup>90</sup> and within the chromosome 5q31 gene cluster that is known to contain an asthma susceptibility gene. Therefore association observed with *IL13* SNPs may simply represent a proxy measure of the effect of polymorphisms in *IL4* or another gene in the region. For example, a recent genome-wide association study of total IgE levels reported significant associations between polymorphisms in an adjacent gene, *RAD50*, and total serum IgE levels,<sup>62</sup> in a region containing a number of evolutionary conserved non-coding sequences that may play a role in regulating *IL4* and *IL13* transcription.<sup>91</sup> However, given the extensive biologic evidence for functionality and recent studies examining polymorphisms across the gene region showing independent effects of the *IL13* R110Q SNP, it is likely that the reported *IL13* associations are real.

Many studies have observed positive associations of specific genetic polymorphisms with differential response to environmental factors in asthma and other respiratory phenotypes.<sup>92,93</sup> *IL13* levels have been shown to be increased in children whose parents smoke<sup>94</sup> and interaction between *IL13* –1112 C/T and smoking with childhood asthma as an outcome has been reported,<sup>95</sup> as well as evidence for this same SNP modulating the adverse effect of smoking on lung function in adults.<sup>96</sup> Thus, differences in smoking exposure between studies may account for some of the differences in findings between studies. DNA methylation is affected by both genetic variants and environment, which may later determine disease risk. For example, Patil et al demonstrated that while rs20541 polymorphisms interacted with maternal smoking to determine methylation at the cg13566430 *IL13* promoter region methylation site, a relationship between the rs1800925 SNP in the *IL13* locus and the same cg13566430 methylation site affected lung function. This demonstrates the ‘two-step’ model of environment and genetic variance affecting disease state, as shown in Figure 3-2.<sup>97</sup>

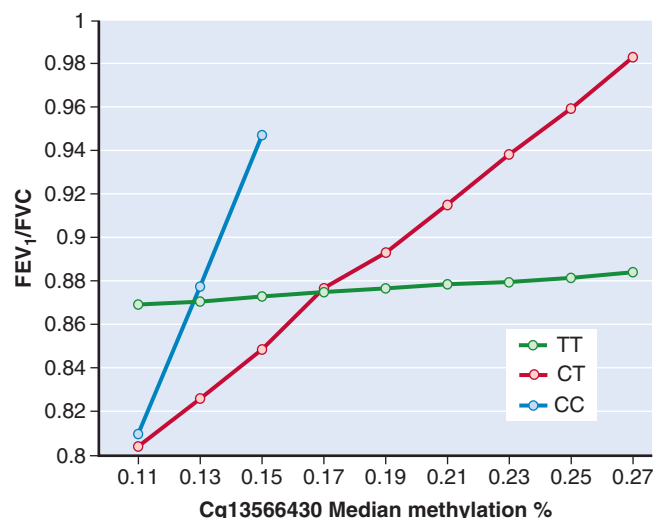

**Figure 3-2** Graph showing effect of interaction between single nucleotide polymorphism (SNP) at rs1800925 (red, blue and green lines show different genotypes) and percentage methylation at cg13566430 on lung function (FEV<sub>1</sub>/FVC). The modifying effect of genotype on the relationship between methylation and lung function demonstrates the interaction of early environment (methylation) and genetics (SNP).<sup>98</sup> FEV<sub>1</sub> – forced expiratory volume in 1 second, FVC – forced vital capacity.

### An Example of a Candidate Gene: Interleukin-33

Since its identification in 2005, *IL-33* has emerged as one of the most important cytokines in Th2 differentiation, and its receptor, ST2, is an excellent marker of Th2 cells.<sup>99</sup> *IL-33* is a member of the *IL-1* family and is located on chromosome 9, therefore separate from the chromosome 5q31 cluster of *IL13* and *IL4*, and not in LD with these genes. Its receptor is encoded by *IL1RL1* on chromosome 2, associated with the *IL1* cluster. *IL33* polymorphisms within two LD blocks have been identified in GWAS as associated with asthma,<sup>56,98,100,101</sup> but these findings have not always been replicated.<sup>70</sup> A number of polymorphisms have also been identified by candidate gene approaches and by both candidate gene and GWAS in the *IL1RL1* gene (*IL-33* receptor).<sup>102</sup> The *IL-33/IL1RL1* pathway has been implicated in the stimulation of type 2 innate lymphoid cells (ILC2s) that produce *IL-4*, *IL-5* and *IL-13*<sup>103</sup> and thus may have a pivotal role in initiating the Th2 phenotype in atopy/asthma. Indeed *IL1RL1* polymorphisms have been shown to be associated with lower levels of *IL1RL1* transcription.<sup>104</sup>

Any observed association of *IL13* or *IL33/IL1RL1* polymorphisms should have its effect reported in context by considering other variation in other relevant genes, whose products may modulate its effects. For example, there are a number of other functional polymorphisms in genes encoding other components of the *IL4/IL13* signaling pathway (*IL4*, *IL13*, *IL4RA*, *IL13R $\alpha$ 1*, *IL13R $\alpha$ 2* and *STAT6*) with synergistic effects.<sup>105</sup> Likewise, the *IL1RL1* locus is closely related to the *IL-18* receptor gene (*IL18R1*), which has a complex LD structure. *IL-18* is associated with Th1 responses and cell adhesion. This difficulty has been reviewed by Grotenboer et al who describe the multiple genetic signals in the *IL33* and *IL1RL1* loci that contribute to asthma pathogenesis. Their suggestion is that the complex LD may be overcome by performing further association studies in other populations with less LD or using meta-analysis with a number of conditional sub-analyses. Further functional and mechanistic studies are also needed.<sup>102</sup>

The *IL13/IL33* polymorphism studies illustrate many of the difficulties of genetic analysis in complex disease. Replication is often not found between studies and this may be accounted for by the lack of power to detect the small increases in disease risk that are typical for susceptibility variants in complex disease. Differences in genetic make-up,<sup>106,107</sup> in environmental exposure between study populations, and failure to 'strictly replicate'<sup>77</sup> in either phenotype (IgE and atopy vs asthma and BHR) or genotype (different polymorphisms in the same gene) can all contribute to the lack of replication between studies. Furthermore, studies of a single polymorphism, or even a single gene in isolation can over-simplify the complex genetic variants in asthma pathogenesis and the cross-talk between implicated cytokines, as shown by the roles of *IL-13*, *IL-33*, *IL1RL1* and Th2/ILC2 cells in asthma pathogenesis.

### ANALYSIS OF CLINICALLY DEFINED SUBGROUPS

One approach is to identify genes in a rare, severely affected subgroup of patients, in whom disease appears to follow a pattern of inheritance that indicates the effect of a single major gene. The assumption is that mutations (polymorphisms) of milder functional effect in the same gene in the general population may play a role in susceptibility to the complex genetic disorder. One example of this has been the identification of the

gene encoding the protein filaggrin as a susceptibility gene for atopic dermatitis.

### Filaggrin

Filaggrin (filament-aggregating protein) has a key role in epidermal barrier function. The protein is a major component of the protein-lipid cornified envelope of the epidermis important for water permeability and blocking the entry of microbes and allergens.<sup>108</sup> In 2002, the condition ichthyosis vulgaris, a severe skin disorder characterized by dry flaky skin and a predisposition to atopic dermatitis and associated asthma, was mapped to the epidermal differentiation complex on chromosome 1q21; this gene complex includes the *filaggrin* gene (*FLG*).<sup>109</sup> In 2006, Smith and colleagues<sup>110</sup> reported that loss of function mutations in the *filaggrin* gene caused ichthyosis vulgaris.

Noting the common occurrence of atopic dermatitis in individuals with ichthyosis vulgaris, these researchers subsequently showed that common loss of function variants (combined carrier frequencies of 9% in the European population<sup>111</sup>) were associated with atopic dermatitis in the general population.<sup>112</sup> Subsequent studies have confirmed an association with atopic dermatitis,<sup>113–115</sup> and also with asthma<sup>116</sup> and allergy<sup>117</sup> but only in the presence of atopic dermatitis. Atopic dermatitis in children is often the first sign of atopic disease and these studies of *filaggrin* mutation have provided a molecular mechanism for the co-existence of asthma and dermatitis. It is thought that deficits in epidermal barrier function could initiate systemic allergy by allergen exposure through the skin and start the 'atopic march' in susceptible individuals.<sup>118,119</sup>

## Molecular Regulation of Atopy and Atopic Disease, II: Disease-Modifying Genes

The concept of genes interacting to alter the effects of mutations in susceptibility genes is not unknown. A proportion of inter-familial variability can be explained by differences in environmental factors and differences in the effect of different mutations in the same gene. Intra-familial variability, especially in siblings, cannot be so readily accredited to these types of mechanisms. Many genetic disorders are influenced by 'modifier' genes that are distinct from the disease susceptibility loci.

### GENETIC INFLUENCES ON DISEASE SEVERITY

Very few studies of the heritability of IgE-mediated disease have examined phenotypes relating to severity. Sarafino and Goldfedder<sup>35</sup> studied 39 monozygotic twin pairs and 55 same-sex dizygotic twin pairs for the heritability of asthma and asthma severity. Asthma severity (as measured by frequency and intensity of asthmatic episodes) was examined in twin pairs concordant for asthma. Severity was significantly correlated for monozygotic pairs but not for dizygotic pairs, suggesting there are distinct genetic factors that determine asthma severity as opposed to susceptibility.

A number of studies have examined associations between asthma severity and polymorphisms in candidate genes but were initially hampered by the lack of clear, easily applied, accurate phenotype definitions for asthma severity that distinguish between the underlying severity and level of therapeutic control. For example, it has been suggested that



$\beta_2$ -adrenergic receptor polymorphisms could influence asthma severity, and the Arg16Gly polymorphism has been associated with measures of asthma severity.<sup>120</sup> However, it is not clear whether  $\beta_2$ -adrenergic receptor polymorphisms affect patients' responses to  $\beta_2$  agonists or, regardless of their effects on treatment, these polymorphisms lead to more severe chronic asthma.<sup>121</sup> GWAS has identified *CDHR3* as being associated with severe asthma<sup>122</sup> and a retrospective study of the Childhood Asthma Management Program (CAMP) cohort showed that variation in the gene encoding the low-affinity IgE receptor, *FCER2*, is associated with high IgE levels and increased frequency of severe exacerbations despite inhaled corticosteroid treatment.<sup>123</sup>

### GENETIC REGULATION OF RESPONSE TO THERAPY: PHARMACOGENETICS

Genetic variability may not only play a role in influencing susceptibility to allergy but may also modify its severity or influence the effectiveness of therapy.<sup>70</sup> In asthma, patient response to drugs such as bronchodilators, corticosteroids and anti-leukotrienes is heterogeneous.<sup>124,125</sup> In the future, identification of such pharmacogenetic factors has the potential to allow individualized treatment plans based on an individual's genetic background.<sup>126</sup> One of the most investigated pharmacogenetic effects has been the effect of polymorphisms at the gene encoding the  $\beta_2$ -adrenergic receptor, *ADRB2*, on the bronchodilator response to inhaled short- and long-acting  $\beta$  agonists.

Clinical studies have shown that  $\beta_2$ -adrenergic receptor polymorphisms may influence the response to bronchodilator treatment. The two most common polymorphisms of the receptor are at amino acid 16 (Arg16Gly) and at amino acid 27 (Gln27Glu).<sup>127</sup> Asthmatic patients carrying the Gly16 polymorphism have been shown to be more prone to develop bronchodilator desensitization,<sup>128</sup> whereas children who are homozygous or heterozygous for Arg16 are more likely to show positive responses to bronchodilators.<sup>129</sup> Studies in vitro have shown that the Gly16 polymorphism increases down-regulation of the  $\beta_2$ -adrenergic receptor after exposure to a  $\beta_2$  agonist. In contrast, the Glu27 polymorphism appears to protect against agonist-induced down-regulation and desensitization of the  $\beta_2$ -adrenergic receptor.<sup>130,131</sup>

However, a study of 190 asthmatics examined whether  $\beta_2$ -adrenergic receptor genotype affects the response to regular versus as-needed albuterol use.<sup>132</sup> During a 16-week treatment period, there was a small but significant decline in morning peak flow in patients homozygous for the Arg16 polymorphism who used albuterol regularly. The effect was magnified during the 4-week run-out period when all patients returned to albuterol as needed. However, other studies have suggested that response to bronchodilator treatment is genotype independent.<sup>133,134</sup>

In contrast to the possible effects on short-acting bronchodilators, pharmacogenetic analysis of  $\beta_2$ -adrenergic receptor polymorphisms has found no effect on response to long-acting  $\beta_2$  agonist therapy in combination with corticosteroids.<sup>135,136</sup> These findings are difficult to explain in the light of the studies discussed linking the Gly16 allele with BHR,  $\beta_2$  agonist effectiveness, and asthma severity but may indicate that the co-administration of corticosteroids abrogates the effect of variation of *ADRB2*. The complexity of the genotype by response effects observed for variation in *ADRB2* makes clinical application limited at this time and may require the use of

detailed haplotypic variation to fully understand the role that variation at this locus plays in regulating  $\beta_2$  agonist response.<sup>137</sup> *ARG1* encoding for arginase 1 is also associated with response to albuterol.<sup>138</sup>

While glucocorticoid therapy is a potent anti-inflammatory treatment for asthma, there is a subset of asthmatics who are poor responders and clinical studies have shown that those with severe disease are more likely to have glucocorticoid resistance.<sup>139</sup> Numerous mutations in the glucocorticoid receptor gene that alter expression, ligand binding and signal transactivation have been identified; however, these are rare and studies in asthma have not revealed an obvious correlation between any specific polymorphism in the glucocorticoid receptor gene and a response to corticosteroid treatment. However, a number of studies have examined variations in components of downstream signaling pathways or other related genes. For example, Tantisirra and colleagues<sup>140</sup> have shown that variation in the *Adenylcyclase 9* gene predicts improved bronchodilator response following corticosteroid treatment, and also identified variation in the *CRHR1* locus<sup>141,142</sup> and the gene encoding *TBX21*<sup>143</sup> as potential markers for steroid responsiveness. Other genes implicated in steroid responsiveness are *STIP*,<sup>144</sup> *GLCCII*<sup>145</sup> and *T*.<sup>146</sup> These discoveries have contributed to the growing recognition of steroid-resistant asthma as a separate phenotype that may be neutrophil-driven rather than eosinophilic.<sup>147</sup>

Genetic polymorphism may also play a role in regulating responses to anti-leukotrienes.<sup>148</sup> In part, this is mediated by polymorphism in both *ALOX5* and other components of the leukotriene biosynthetic pathway such as *GPR99*.<sup>149–151</sup> There is also a substantial overlap in the genetic modulation of response to the two classes of leukotriene modifier drugs (5-LO inhibitor and Cysteinyl LT1 receptor antagonists).<sup>152</sup> Genetic variation in the leukotriene biosynthetic pathway has also been shown to be associated with increased susceptibility to several chronic disease phenotypes including myocardial infarction,<sup>153,154</sup> stroke,<sup>154,155</sup> atherosclerosis<sup>156</sup> and asthma,<sup>157</sup> suggesting variation in leukotriene production increases risk and severity of inflammation in many conditions. *ALOX5* polymorphisms have also been linked to asthma severity.<sup>158</sup>

Increasingly, there is a focus on developing immune response modifier biologicals of asthma cytokines such as IL-4, IL-13, IL-5 and IL-33. Pikantra is a biological developed as an IL-4 variant that inhibits the IL-4/13 pathway, but response is dependent on *IL4R* genotype.<sup>159</sup>

The aim of pharmacogenetic approaches is to maximize the therapeutic response and minimize any side-effects and although there is no direct pharmacogenetic test for asthma treatment, there is a growing body of research suggesting that development of these tests would be of great benefit to develop new drugs, tailor treatment to those who will most benefit (improving cost-effectiveness) and provide better control of asthma.

## Epigenetics and Allergic Disease

The important role of epigenetics as a mechanism by which the environment can alter disease risk in an individual is being increasingly recognized. The term *epigenetics* refers to biological processes that regulate gene activity but do not involve changes in the DNA sequence. Epigenetic processes include post-translational modification of histones by acetylation and methylation, and DNA methylation. Modification of histones,

around which the DNA is coiled, alters the tightness with which the chromatin fiber is packed and affects rate of transcription. DNA methylation involves the addition of a methyl group to specific cytosine bases, altering gene expression. Increased DNA methylation in the promoter is typically associated with decreased gene expression, whereas within the body of the gene it is associated with increased gene expression, and around exon boundaries it can affect alternative splicing. DNA methylation patterns can be heritable across both cellular divisions and organismal generations. Epigenetic marks are altered by environmental exposures experienced by the individual, and these changes can last decades.

There is evidence that epigenetic factors are important in allergic disease. Epigenetic profiles differ between individuals with and without allergic disease,<sup>160,161</sup> though it is important to note that in most cases these epigenetic changes can be both causes and consequences of allergic disease. Importantly, changes to histone modifications and DNA methylation can be induced by risk factors for allergy such as tobacco smoke, caesarean birth and maternal nutrition in early life.<sup>162</sup> This evidence strongly supports epigenetics as a mechanism by which the environment affects allergic disease risk and a mechanism by which gene-environment interaction can occur. Indeed, interactions between genetic variants and DNA methylation have been observed in asthma,<sup>72</sup> lung function<sup>97</sup> (Figure 3-2) and eczema.<sup>163</sup>

However, in itself, environmentally induced epigenetic change to an individual's epigenome cannot explain the observed heritability of allergic disease – this would require the epigenetic change to be inherited through meiosis and the effect of exposure in one generation to lead to increased risk in subsequent generations. In humans, trans-generational effects have been observed where the initial environmental exposure occurred in F0 generation and changes in disease susceptibility were still evident in F2 (grandchildren). Pembrey and colleagues<sup>164</sup> showed that exposures such as poor nutrition or smoking during the slow growth period of the F0 generation resulted in effects on life expectancy and growth through the male line and female line in the F2 generation, although there had been no further exposure. In mouse models, ancestral folate deprivation causes congenital malformations that persist for five generations, most likely via epigenetics.<sup>165</sup> Observations such as grandmaternal smoking increasing the risk of childhood asthma in their grandchildren<sup>166</sup> support the concept that trans-generational epigenetic effects may be operating in allergic disease. This is further supported by the study of animal models, for example in one model where mice were exposed to in utero supplementation with methyl donors and exhibited enhanced airway inflammation following allergen challenge.<sup>167</sup> It is probable in the near future that the study of large prospective birth cohorts with information on maternal environmental exposures during pregnancy will provide important insights into the role of epigenetic factors in the heritability of allergic disease.<sup>168</sup>

## Conclusions

The varying and sometimes conflicting results of studies to identify allergic disease susceptibility genes reflect the genetic and environmental heterogeneity seen in allergic disorders and illustrate the difficulty of identifying susceptibility genes for complex genetic diseases. This is the result of a number of factors, including difficulties in defining phenotypes and population heterogeneity with different genetic loci showing

association in populations of differing ethnicity and differing environmental exposure. However, despite this, there is now a rapidly expanding list of genes robustly associated with a wide range of allergic disease phenotypes.

This leads to the question, is it possible to predict the likelihood that an individual will develop allergic disease? To an extent, clinicians already make some predictions of the risk of developing allergic disease through the use of family history and this has been shown to have some validity.<sup>169</sup> However, at present, we are not in a position to utilize the rapidly accumulating knowledge of genetic variants that influence allergic disease progression in clinical practice. This simply reflects the complex interactions between different genetic and environmental factors required both to initiate disease and determine progression to a more severe phenotype in an individual, meaning that the predictive value of variation in any one gene is low, with a typical genotype relative risk of 1.1–1.5.<sup>170</sup>

However, it is possible that, as our knowledge of the genetic factors underlying disease increases, the predictive power of genetic testing will increase sufficiently to enable its use in clinical decision making (Box 3-1). For example, simulation studies based on the use of 50 genes relevant for disease development demonstrated that an area under a curve (AUC) of 0.8 can be reached if the genotype relative risk is 1.5 and the risk allele frequency is 10%.<sup>170,171</sup> Whether this is likely to improve on diagnostics using traditional risk factor assessment is a separate issue. Analyses of the power of genetic testing to predict risk of non-insulin-dependent diabetes (for which many more genetic risk factors have been identified through genome-wide approaches than for allergic disease at this stage) demonstrate that, currently, the inclusion of common genetic variants has only a small effect on the ability to predict the future development of the condition.<sup>172,173</sup> This has led some to question the 'disproportionate attention and resources' given to genetic studies in the prevention of common disease.<sup>174</sup> However, the identification of further risk factors and the development of better methods for incorporating genetic factors into risk models are likely to substantially increase the value of genotypic risk factors and may also provide a means for predicting progression to severe disease and targeting of preventative treatment in the future.<sup>175</sup>

### BOX 3-1 KEY CONCEPTS

#### What Can Genetics Studies of Allergic Disease Tell Us?

##### Greater Understanding of Disease Pathogenesis

- Identification of novel genes and pathways leading to new pharmacologic targets for developing therapeutics

##### Identification of Environmental Factors that Interact with an Individual's Genetic Make-up to Initiate Disease

- Prevention of disease by environmental modification

##### Identification of Susceptible Individuals

- Early-in-life screening and targeting of preventative therapies to at-risk individuals to prevent disease

##### Targeting of Therapies

- Subclassification of disease on the basis of genetics and targeting of specific therapies based on this classification
- Determination of the likelihood of an individual responding to a particular therapy (pharmacogenetics) and individualized treatment plans

Whatever the future value of genetic studies of allergic disease in predicting risk, it is unlikely that this will be the area of largest impact of genetics studies on the treatment and prevention of these conditions. Rather, it is the insight the genetic studies have provided, and undoubtedly will continue to provide, into disease pathogenesis. It is clear from genetic studies of allergic disease that the propensity to develop atopy is influenced by factors different than those that influence atopic disease. However, these disease factors require interaction with atopy (or something else) to trigger disease. For

example, in asthma, bronchoconstriction is triggered mostly by an allergic response to inhaled allergen accompanied by eosinophilic inflammation in the lungs, but in some people who may have ‘asthma susceptibility genes’ but not atopy, asthma is triggered by other exposures, such as toluene di-isocyanate.<sup>57</sup> It is possible to group the genes identified into four broad groups (Figure 3-3). Firstly, there is a group of genes that are involved in directly modulating response to environmental exposures. These include genes encoding components of the innate immune system that interact with levels of microbial exposure

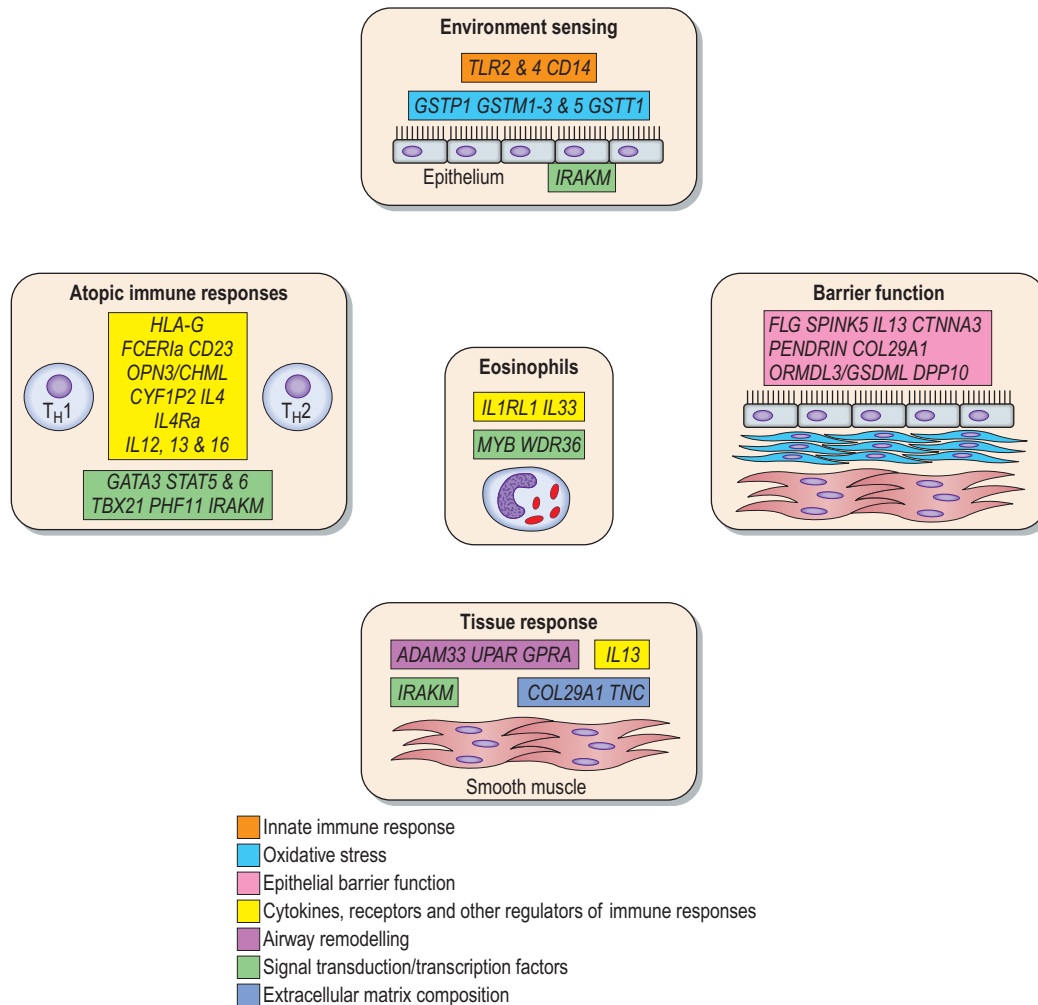

**Figure 3-3** Susceptibility genes for allergic disease: a large number of robustly associated genes have been identified that predispose to allergic disease. These can be broadly divided into four main groups. **Group 1 – sensing the environment.** This group of genes encodes molecules that directly modulate the effect of environmental risk factors for allergic disease. For example, genes such as *TLR2*, *TLR4* and *CD14* encoding components of the innate immune system interact with levels of microbial exposure to alter risk of developing allergic immune responses. Polymorphism of glutathione-S-transferase genes (*GSTM1*, -2, -3, and -5, *GSTT1* and *GSTP1*) has been shown to modulate the effect of exposures involving oxidant stress such as tobacco smoke and air pollution on asthma susceptibility. **Group 2 – barrier function.** The body is also protected from environmental exposure through the direct action of the epithelial barrier both in the airways and in the dermal barrier of the skin. A high proportion of the novel genes identified for susceptibility to allergic disease through genome-wide linkage and association approaches has been shown to be expressed in the epithelium. This includes genes such as *FLG* that directly affect dermal barrier function and are associated not only with increased risk of atopic dermatitis but also with increased atopic sensitization and inflammatory products produced directly by the epithelium such as chemokines and defensins. Other novel genes such as *ORMDL3/GSDML* are also expressed in the epithelium and may have a role in possibly regulating epithelial barrier function. **Group 3 – regulation of (atopic) inflammation.** This group of genes includes genes that regulate Th1/Th2 differentiation and effector function such as *IL13*, *IL4RA*, *STAT6*, *TBX21* (encoding T-bet) and *GATA3*, as well as genes such as *IRAKM* and *PHF11* that potentially regulate both atopic sensitization and the level of inflammation that occurs at the end organ location for allergic disease (airway, skin, nose, etc.). This also includes the genes recently identified as regulating the level of blood eosinophilia using a GWAS approach (*IL1RL1*, *IL33*, *MYB* and *WDR36*). **Group 4 – tissue response genes.** This group of genes appears to modulate the consequences of chronic inflammation such as airway remodeling. They include genes such as *ADAM33* expressed in fibroblasts and smooth muscle and *COL29A1*, encoding a novel collagen expressed in the skin and linked to atopic dermatitis. It is important to recognize that some genes may affect more than one component, for example *IL13* may regulate atopic sensitization through switching B cells to produce IgE but also has direct effects on the airway epithelium and mesenchyme promoting goblet cell metaplasia and fibroblast proliferation.

to alter risk of developing allergic immune responses as well as detoxifying enzymes such as the Glutathione S-transferase genes that modulate the effect of exposures involving oxidant stress, such as tobacco smoke and air pollution. The second major group that includes many of the genes identified through hypothesis independent genome-wide approaches is a group of genes involved in maintaining the integrity of the epithelial barrier at the mucosal surface and signaling of the epithelium to the immune system following environmental exposure. For example, polymorphisms in *FLG* that directly affect dermal barrier function are associated, not only with increased risk of atopic dermatitis, but also with increased atopic sensitization. The third group of genes are those that regulate the immune response, including those such as *IL13*, *RAD50*, *IL4RA*, *STAT6*, *TBX21* (encoding Tbet), *FCER1A*, *HLA* and *GATA3* that regulate Th1/Th2 differentiation and effector function, but also others such as *IRAKM* and *PHF11* that may regulate the level of inflammation that occurs at the end organ for allergic disease (i.e. airway, skin, nose, etc.). Finally, but not least, a number of genes appear to be involved in determining the tissue response to chronic inflammation, such as airway remodeling. They include genes such as *ADAM33* expressed in fibroblasts and smooth muscle and *COL29A1* encoding a novel collagen expressed in the skin and linked to atopic dermatitis.

Thus, the insights provided by the realization that genetic variation in genes regulating atopic immune responses is not the only, or even the major, factor in determining susceptibility to allergic disease, have highlighted the importance of local tissue response factors and epithelial susceptibility factors in the pathogenesis of allergic disease.<sup>176</sup> This is possibly the greatest contribution that genetic studies have made to the study of allergic disease and where the most impact in the form of new therapeutics targeting novel pathways of disease pathogenesis is likely to occur.

In conclusion, over the past 15 years, there have been many linkage and association studies examining genetic susceptibility to atopy and allergic disease resulting in the unequivocal identification of a number of loci that alter the susceptibility of an individual to allergic disease. While further research is needed to confirm previous studies and to understand how these genetic variants alter gene expression and/or protein function, and therefore contribute to the pathogenesis of disease, genetic studies have already helped to change our understanding of these conditions. In the future, the study of larger cohorts and the pooling of data across studies will be needed to allow the determination of the contribution of identified polymorphisms

### BOX 3-2 KEY CONCEPTS

#### GENETIC EFFECTS ON ALLERGY AND ALLERGIC DISEASE

##### Determine Susceptibility Atopy

- 'Th2' or 'IgE switch' genes  
Determine specific target-organ disease in atopic individuals
- Asthma susceptibility genes  
'Lung-specific factors' that regulate susceptibility of lung epithelium/fibroblasts to remodeling in response to allergic inflammation, such as *ADAM33*
- Atopic dermatitis susceptibility genes  
Genes that regulate dermal barrier function, such as *FLG*

##### Influence the Interaction of Environmental Factors with Atopy and Allergic Disease

- Determining immune responses to factors that drive Th1/Th2 skewing of the immune response, such as *CD14* and *TLR4* polymorphism and early childhood infection
- Modulating the effect of exposures involving oxidant stress such as tobacco smoke and air pollution on asthma susceptibility
- Altering interaction between environmental factors and established disease, such as genetic polymorphism regulating responses to respiratory syncytial virus infection and asthma symptoms

##### Modify Severity of Disease

- Examples are tumor necrosis factor  $\alpha$  and *CDHR3* polymorphisms

##### Regulate Response to Therapy

- Pharmacogenetics
- Examples are  $\beta_2$ -adrenergic receptor polymorphism and response to  $\beta_2$  agonists

to susceptibility and how these polymorphisms interact with each other and the environment to initiate allergic disease. Furthermore it is now apparent that the added complexity of epigenetic influences on allergic disease needs to be considered. Despite these challenges for the future, genetic approaches to the study of allergic disease have clearly shown that they can lead to identification of new biologic pathways involved in the pathogenesis of allergic disease, the development of new therapeutic approaches and the identification of at-risk individuals (Box 3-2).

The complete reference list can be found on the companion Expert Consult website at <http://www.expertconsult.inkling.com>.

### KEY REFERENCES

- Frazer KA, Murray SS, Schork NJ, Topol EJ. Human genetic variation and its contribution to complex traits. *Nat Rev Genet* 2009;10:241–51.
- McCarthy MI, Abecasis GR, Cardon LR, Goldstein DB, Little J, Ioannidis JP, et al. Genome-wide association studies for complex traits: consensus, uncertainty and challenges. *Nat Rev Genet* 2008;9:356–69.
- Moffatt MF, Kabisch M, Liang L, Dixon AL, Strachan D, Heath S, et al. Genetic variants regulating *ORMDL3* expression contribute to the risk of childhood asthma. *Nature* 2007;448:470–3.
- Moffatt MF, Gut IG, Demenais F, Strachan DP, Bouzigon E, Heath S, et al. A large-scale, consortium-based genome-wide association study of asthma. *N Engl J Med* 2010;363:1211–21.
- Bønnelykke K, Matheson MC, Pers TH, Granell R, Strachan DP, Alves AC, et al. Meta-analysis of genome-wide association studies identifies ten loci influencing allergic sensitization. *Nat Genet* 2013;45:902–6.
- Weidinger S, Willis-Owen SA, Kamatani Y, Baurecht H, Morar N, Liang L, et al. A genome-wide association study of atopic dermatitis identifies loci with overlapping effects on asthma and psoriasis. *Hum Mol Genet* 2013;22:4841–56.
- Patil VK, Holloway JW, Zhang H, Soto-Ramirez N, Ewart S, Arshad SH, et al. Interaction of prenatal maternal smoking, interleukin 13 genetic variants and DNA methylation influencing airflow and airway reactivity. *Clin Epigenetics* 2013;5:22.
- Palmer CN, Irvine AD, Terron-Kwiatkowski A, Zhao Y, Liao H, Lee SP, et al. Common loss-of-function variants of the epidermal barrier protein filaggrin are a major predisposing factor for atopic dermatitis. *Nat Genet* 2006;38:441–6.
- Martino D, Joo JE, Sexton-Oates A, Dang T, Allen K, Saffery R, et al. Epigenome-wide association study reveals longitudinally stable DNA methylation differences in CD4+ T cells from children with IgE-mediated food allergy. *Epigenetics* 2014;9:998–1006.
- Holgate ST, Davies DE, Powell RM, Howarth PH, Haitchi HM, Holloway JW. Local genetic and environmental factors in asthma disease pathogenesis: chronicity and persistence mechanisms. *Eur Respir J* 2007;29:793–803.



## REFERENCES

- Cookson WO, Sharp PA, Faux JA, Hopkin JM. Linkage between immunoglobulin E responses underlying asthma and rhinitis and chromosome 11q. *Lancet* 1989;1:1292–5.
- Kerem B, Rommens JM, Buchanan JA, Markiewicz D, Cox TK, Chakravarti A, et al. Identification of the cystic fibrosis gene: genetic analysis. *Science* 1989;245:1073–80.
- Botstein D, White RL, Skolnick M, Davis RW. Construction of a genetic linkage map in man using restriction fragment length polymorphisms. *Am J Hum Genet* 1980;32:314–31.
- Pearce N, Weiland S, Keil U, Langridge P, Anderson HR, Strachan D, et al. Self-reported prevalence of asthma symptoms in children in Australia, England, Germany and New Zealand: an international comparison using the ISAAC protocol. *Eur Respir J* 1993;6:1455–61.
- King MC, Lee GM, Spinner NB, Thomson G, Wensch MR. Genetic epidemiology. *Annu Rev Public Health* 1984;5:1–52.
- Farrer LA, Cupples LA. Determining the genetic component of a disease. In: Haines JL, Pericak-Vance MA, editors. Approaches to gene mapping in complex human diseases. New York, USA: Wiley-Liss, Inc.; 1998.
- Haldar P, Pavord ID, Shaw DE, Berry MA, Thomas M, Brightling CE, et al. Cluster analysis and clinical asthma phenotypes. *Am J Respir Crit Care Med* 2008;178:218–24.
- Weatherall M, Travers J, Shirtcliffe PM, Marsh SE, Williams MV, Nowitz MR, et al. Distinct clinical phenotypes of airways disease defined by cluster analysis. *Eur Respir J* 2009;34:812–18.
- Frazer KA, Murray SS, Schork NJ, Topol EJ. Human genetic variation and its contribution to complex traits. *Nat Rev Genet* 2009;10:241–51.
- Feuk L, Marshall CR, Wintle RF, Scherer SW. Structural variants: changing the landscape of chromosomes and design of disease studies. *Hum Mol Genet* 2006;15(Spec1):R57–66.
- Levy S, Sutton G, Ng PC, Feuk L, Halpern AL, Walenz BP, et al. The diploid genome sequence of an individual human. *PLoS Biol* 2007;5:e254.
- Peddle L, Rahman P. Genetic epidemiology of complex phenotypes. *Methods Mol Biol* 2009;473:187–201.
- Almasy L, Blangero J. Contemporary model-free methods for linkage analysis. *Adv Genet* 2008;60:175–93.
- Cooper RS, Tayo B, Zhu X. Genome-wide association studies: implications for multiethnic samples. *Hum Mol Genet* 2008;17:R151–5.
- Spielman RS, McGinnis RE, Ewens WJ. Transmission test for linkage disequilibrium: the insulin gene region and insulin-dependent diabetes mellitus (IDDM). *Am J Hum Genet* 1993;52:506–16.
- Spielman RS, Ewens WJ. The TDT and other family-based tests for linkage disequilibrium and association. *Am J Hum Genet* 1996;59:983–9.
- International HapMap Consortium. A haplotype map of the human genome. *Nature* 2005;437:1299–320.
- Altshuler D, Daly MJ, Lander ES. Genetic mapping in human disease. *Science* 2008;322:881–8.
- McCarthy MI, Abecasis GR, Cardon LR, Goldstein DB, Little J, Ioannidis JP, et al. Genome-wide association studies for complex traits: consensus, uncertainty and challenges. *Nat Rev Genet* 2008;9:356–69.
- Hindorf LA, MacArthur J, Morales J, Junkins HA, Hall PN, Klemm AK, et al. A catalog of published genome-wide association studies. Available at: <[www.genome.gov/26525384](http://www.genome.gov/26525384)>. Accessed 24 March 2014.
- Amos CI. Successful design and conduct of genome-wide association studies. *Hum Mol Genet* 2007;16(Spec2):R220–5.
- Lam AC, Powell J, Wei WH, de Koning DJ, Haley CS. A combined strategy for quantitative trait loci detection by genome-wide association. *BMC Proc* 2009;3(Suppl. 1):S6.
- Coca A, Cooke R. On the classification of the phenomena of hypersensitiveness. *J Immunol* 1923;8:163–80.
- Lawrence S, Beasley R, Doull I, Begishvili B, Lampe F, Holgate ST, et al. Genetic analysis of atopy and asthma as quantitative traits and ordered polychotomies. *Ann Human Genet* 1994;58:359–68.
- Wilkinson J, Grimley S, Collins A, Thomas NS, Holgate ST, Morton N. Linkage of asthma to markers on chromosome 12 in a sample of 240 families using quantitative phenotype scores. *Genomics* 1998;53:251–9.
- Cooke RA, Vander Veer A. Human sensitisation. *J Immunol* 1916;16:201–305.
- Hayashi T, Kawakami N, Kondo N, Agata H, Fukutomi O, Shimizu H, et al. Prevalence of and risk factors for allergic diseases: comparison of two cities in Japan. *Ann Allergy Asthma Immunol* 1995;75:525.
- Jenkins MA, Hopper JL, Giles GG. Regressive logistic modeling of familial aggregation for asthma in 7,394 population-based nuclear families. *Genet Epidemiol* 1997;14:317–32.
- Bazaraal M, Orgel HA, Hamburger RN. IgE levels in normal infants and mothers and an inheritance hypothesis. *J Immunol* 1971;107:794–801.
- Gerrard JW, Vickers P, Gerrard CD. The familial incidence of allergic disease. *Ann Allergy* 1976;36:10–15.
- Dold S, Wjst M, von Mutius E, Reitmeir P, Stiepel E. Genetic risk for asthma, allergic rhinitis, and atopic dermatitis. *Arch Dis Child* 1992;67:1018–22.
- von Mutius E, Nicolai T. Familial aggregation of asthma in a South Bavarian population. *Am J Respir Crit Care Med* 1996;153:1266–72.
- Duffy DL, Martin NG, Battistutta D, Hopper JL, Matthews JD. Genetics of asthma and hay fever in Australian twins. *Am Rev Respir Dis* 1990;142:1351–8.
- Wuthrich B, Baumann E, Fries RA, Schnyder UW. Total and specific IgE (RAST) in atopic twins. *Clin Allergy* 1981;11:147–54.
- Sarafino EP, Goldfeder J. Genetic factors in the presence, severity, and triggers of asthma. *Arch Dis Child* 1995;73:112–16.
- Husby S, Holm NV, Christensen K, Skov R, Morling N, Petersen PH. Cord blood immunoglobulin E in like-sexed monozygotic and dizygotic twins. *Clin Genet* 1996;50:332–8.
- Hopp RJ, Bewtra AK, Watt GD, Nair NM, Townley RG. Genetic analysis of allergic disease in twins. *J Allergy Clin Immunol* 1984;73:265–70.
- Harris JR, Magnus P, Samuelson SO, Tambs K. No evidence for effects of family environment on asthma: a retrospective study of Norwegian twins. *Am J Respir Crit Care Med* 1997;156:43–9.
- Hanson B, McGue M, Roitman-Johnson B, Segal NL, Bouchard TJ Jr, Blumenthal MN. Atopic disease and immunoglobulin E in twins reared apart and together. *Am J Hum Genet* 1991;48:873–9.
- Sibbald B, Horn ME, Gregg I. A family study of the genetic basis of asthma and wheezy bronchitis. *Arch Dis Child* 1980;55:354–7.
- Sibbald B, Turner-Warwick M. Factors influencing the prevalence of asthma among first degree relatives of extrinsic and intrinsic asthmatics. *Thorax* 1979;34:332–7.
- Longo G, Strinati R, Poli F, Fumi F. Genetic factors in nonspecific bronchial hyperreactivity: an epidemiologic study. *Am J Dis Child* 1987;141:331–4.
- Laitinen T, Rasanen M, Kaprio J, Koskenvuo M, Laitinen LA. Importance of genetic factors in adolescent asthma: a population-based twin-family study. *Am J Respir Crit Care Med* 1998;157:1073–8.
- Skadhauge LR, Christensen K, Kyvik KO, Sigsgaard T. Genetic and environmental influence on asthma: a population-based study of 11,688 Danish twin pairs. *Eur Respir J* 1999;13:8–14.
- Ober C. Susceptibility genes in asthma and allergy. *Curr Allergy Asthma Rep* 2001;1:174–9.
- Ober C, Hoffjan S. Asthma genetics 2006: the long and winding road to gene discovery. *Genes Immun* 2006;7:95–100.
- Moffatt MF, Kabisch M, Liang L, Dixon AL, Strachan D, Heath S, et al. Genetic variants regulating ORMDL3 expression contribute to the risk of childhood asthma. *Nature* 2007;448:470–3.
- Galanter J, Choudhry S, Eng C, Nazario S, Rodriguez-Santana JR, Casal J, et al. ORMDL3 gene is associated with asthma in three ethnically diverse populations. *Am J Respir Crit Care Med* 2008;177:1194–200.
- Leung TF, Sy HY, Ng MC, Chan IH, Wong GW, Tang NL, et al. Asthma and atopy are associated with chromosome 17q21 markers in Chinese children. *Allergy* 2009;64:621–8.
- Tavendale R, Macgregor DF, Mukhopadhyay S, Palmer CN. A polymorphism controlling ORMDL3 expression is associated with asthma that is poorly controlled by current medications. *J Allergy Clin Immunol* 2008;121:860–3.
- Wu H, Romieu J, Sienna-Monge JJ, Li H, del Rio-Navarro BE, London SJ. Genetic variation in ORM1-like 3 (ORMDL3) and gasdermin-like (GSDML) and childhood asthma. *Allergy* 2009;64:629–35.
- Moffatt MF, Gut IG, Demenais F, Strachan DP, Bouzigon E, Heath S, et al. A large-scale, consortium-based genomewide association study of asthma. *N Engl J Med* 2010;363:1211–21.
- Bouzigon E, Corda E, Aschard H, Dizier MH, Boland A, Bousquet J, et al. Effect of 17q21 variants and smoking exposure in early-onset asthma. *N Engl J Med* 2008;359:1985–94.
- Smemo S, Tena JJ, Kim K-H, Gamazon ER, Sakabe NJ, Gomez-Marín C, et al. Obesity-associated variants within FTO form long-range functional connections with IRX3. *Nature* 2014;507:371–5.

55. Duan S, Huang RS, Zhang W, Bleibel WK, Roe CA, Clark TA, et al. Genetic architecture of transcript-level variation in humans. *Am J Hum Genet* 2008;82:1101–13.
56. Gudbjartsson DF, Bjornsdottir US, Halapi E, Helgadóttir A, Sulem P, Jonsdóttir GM, et al. Sequence variants affecting eosinophil numbers associate with asthma and myocardial infarction. *Nat Genet* 2009;41:342–7.
57. Kim SH, Cho BY, Park CS, Shin ES, Cho EY, Yang EM, et al. Alpha-T-catenin (CTNNA3) gene was identified as a risk variant for toluene diisocyanate-induced asthma by genome-wide association analysis. *Clin Exp Allergy* 2009;39:203–12.
58. Weidinger S, Gieger C, Rodriguez E, Baurecht H, Mempel M, Klopp N, et al. Genome-wide scan on total serum IgE levels identifies FCER1A as novel susceptibility locus. *PLoS Genet* 2008;4:e1000166.
59. Esparza-Gordillo J, Weidinger S, Folster-Holst R, Bauerfeind F, Ruschendorf F, Patone G, et al. A common variant on chromosome 11q13 is associated with atopic dermatitis. *Nat Genet* 2009;41:596–601.
60. Bønnelykke K, Matheson MC, Pers TH, Granell R, Strachan DP, Alves AC, et al. Meta-analysis of genome-wide association studies identifies ten loci influencing allergic sensitization. *Nat Genet* 2013;45:902–6.
61. Paternoster L, Standl M, Chen C-M, Ramasamy A, Bønnelykke K, Duijts L, et al. Meta-analysis of genome-wide association studies identifies three new risk loci for atopic dermatitis. *Nat Genet* 2012;44:187–92.
62. Weidinger S, Willis-Owen SA, Kamatani Y, Baurecht H, Morar N, Liang L, et al. A genome-wide association study of atopic dermatitis identifies loci with overlapping effects on asthma and psoriasis. *Hum Mol Genet* 2013;22:4841–56.
63. Sun L-D, Xiao F-L, Li Y, Zhou WM, Tang HY, Tang XF, et al. Genome-wide association study identifies two new susceptibility loci for atopic dermatitis in the Chinese Han population. *Nat Genet* 2011;43:690–4.
64. Ramasamy A, Curjuric I, Coin LJ, Kumar A, McArdle WL, Imboden M, et al. A genome-wide meta-analysis of genetic variants associated with allergic rhinitis and grass sensitization and their interaction with birth order. *J Allergy Clin Immunol* 2011;128:996–1005.
65. Andiappan AK, Wang DY, Anantharaman R, Parate PN, Suri BK, Low HQ, et al. Genome-wide association study for atopy and allergic rhinitis in a Singapore Chinese population. *PLoS ONE* 2011;6:e19719.
66. Bunyavanich S, Shargorodsky J, Celedón JC. A meta-analysis of Th2 pathway genetic variants and risk for allergic rhinitis. *Pediatr Allergy Immunol* 2011;22:378–87.
67. Ferreira MAR, Matheson MC, Tang CS, Granell R, Ang W, Hui J, et al. Genome-wide association analysis identifies 11 risk variants associated with the asthma with hay fever phenotype. *J Allergy Clin Immunol* 2014;133:1564–71.
68. Tan TH-T, Ellis JA, Saffery R, Allen KJ. The role of genetics and environment in the rise of childhood food allergy. *Clin Exp Allergy* 2012;42:20–9.
69. Tulah AS, Holloway JW, Sayers I. Defining the contribution of SNPs identified in asthma GWAS to clinical variables in asthmatic children. *BMC Med Genet* 2013;14:100.
70. Bønnelykke K, Sleiman P, Nielsen K, Kreiner-Møller E, Mercader JM, Belgrave D, et al. A genome-wide association study identifies CDHR3 as a susceptibility locus for early childhood asthma with severe exacerbations. *Nat Genet* 2014;46:51–5.
71. Tomita K, Sakashita M, Hirota T, Tanaka S, Masuyama K, Yamada T, et al. Variants in the 17q21 asthma susceptibility locus are associated with allergic rhinitis in the Japanese population. *Allergy* 2013;68:92–100.
72. Soto-Ramírez N, Arshad SH, Holloway JW, Zhang H, Schaubberger E, Ewart S, et al. The interaction of genetic variants and DNA methylation of the interleukin-4 receptor gene increase the risk of asthma at age 18 years. *Clin Epigenetics* 2013;5:1.
73. Maher B. Personal genomes: the case of the missing heritability. *Nature* 2008;456:18–21.
74. Vercelli D. Discovering susceptibility genes for asthma and allergy. *Nat Rev Immunol* 2008;8:169–82.
75. Weiss ST. Association studies in asthma genetics. *Am J Respir Crit Care Med* 2001;164:2014–15.
76. Hall I. Candidate gene studies in respiratory disease: avoiding the pitfalls. *Thorax* 2002;57:377–8.
77. Tabor HK, Risch NJ, Myers RM. Candidate gene approaches for studying complex genetic traits: practical considerations. *Nat Rev Genet* 2002;3:391–7.
78. Holloway JW, Koppelman GH. Identifying novel genes contributing to asthma pathogenesis. *Curr Opin Allergy Clin Immunol* 2007;7:69–74.
79. Frazer KA, Ueda Y, Zhu Y, Gifford VR, Garofalo MR, Mohandas N, et al. Computational and biological analysis of 680 kb of DNA sequence from the human 5q31 cytokine gene cluster region. *Genome Res* 1997;7:495–512.
80. Hoffjan S, Nicolae D, Ober C. Association studies for asthma and atopic diseases: a comprehensive review of the literature. *Respir Res* 2003;4:14.
81. van der Pouw Kraan T, van Veen A, Boeijs L, van Tuyl SA, de Groot ER, Stapel SO, et al. An IL-13 promoter polymorphism associated with increased risk of allergic asthma. *Genes Immun* 1999;1:61–5.
82. Kasaian MT, Miller DK. IL-13 as a therapeutic target for respiratory disease. *Biochem Pharmacol* 2008;76:147–55.
83. Graves PE, Kabcsh M, Halonen M, Holberg CJ, Baldini M, Fritsch C, et al. A cluster of seven tightly linked polymorphisms in the IL-13 gene is associated with total serum IgE levels in three populations of white children. *J Allergy Clin Immunol* 2000;105:506–13.
84. Heinzmann A, Mao XQ, Akaiwa M, Kreomer RT, Gao PS, Ohshima K, et al. Genetic variants of IL-13 signalling and human asthma and atopy. *Hum Mol Genet* 2000;9:549–59.
85. Pantelidis P, Jones MG, Welsh KI, Taylor AN, du Bois RM. Identification of four novel interleukin-13 gene polymorphisms. *Genes Immun* 2000;1:341–5.
86. Vladich FD, Brazille SM, Stern D, Peck ML, Ghittoni R, Vercelli D. IL-13 R130Q, a common variant associated with allergy and asthma, enhances effector mechanisms essential for human allergic inflammation. *J Clin Invest* 2005;115:747–54.
87. Andrews AL, Bucchieri F, Arima K, Izuhara K, Holgate ST, Davies DE, et al. Effect of IL-13 receptor alpha2 levels on the biological activity of IL-13 variant R110Q. *J Allergy Clin Immunol* 2007;120:91–7.
88. Liu X, Nickel R, Beyer K, Wahn U, Ehrlich E, Freidhoff LR, et al. An IL13 coding region variant is associated with a high total serum IgE level and atopic dermatitis in the German multicenter atopy study (MAS-90). *J Allergy Clin Immunol* 2000;106:167–70.
89. Howard TD, Whittaker PA, Zaiman AL, Koppelman GH, Xu J, Hanley MT, et al. Identification and association of polymorphisms in the interleukin-13 gene with asthma and atopy in a Dutch population. *Am J Respir Cell Mol Biol* 2001;25:377–84.
90. Li Y, Guo B, Zhang L, Han J, Wu B, Xiong H. Association between C-589T polymorphisms of interleukin-4 gene promoter and asthma: a meta-analysis. *Respir Med* 2008;102:984–92.
91. Loots GG, Locksley RM, Blankespoor CM, Wang ZE, Miller W, Rubin EM, et al. Identification of a coordinate regulator of interleukins 4, 13, and 5 by cross-species sequence comparisons. *Science* 2000;288:136–40.
92. Le Souef PN. Gene-environmental interaction in the development of atopic asthma: new developments. *Curr Opin Allergy Clin Immunol* 2009;9:123–7.
93. von Mutius E. Gene-environment interactions in asthma. *J Allergy Clin Immunol* 2009;123:3–11, quiz 2–3.
94. Feleszko W, Zawadzka-Krajewska A, Matysiak K, Lewandowska D, Peradzynska J, Dinh QT, et al. Parental tobacco smoking is associated with augmented IL-13 secretion in children with allergic asthma. *J Allergy Clin Immunol* 2006;117:97–102.
95. Sadeghnejad A, Karmaus W, Arshad SH, Kurukulaaratchy R, Huebner M, Ewart S. IL13 gene polymorphisms modify the effect of exposure to tobacco smoke on persistent wheeze and asthma in childhood: a longitudinal study. *Respir Res* 2008;9:2.
96. Sadeghnejad A, Meyers DA, Bottai M, Sterling DA, Bleeker ER, Ohar JA. IL13 promoter polymorphism 1112C/T modulates the adverse effect of tobacco smoking on lung function. *Am J Respir Crit Care Med* 2007;176:748–52.
97. Patil VK, Holloway JW, Zhang H, Soto-Ramirez N, Ewart S, Arshad SH, et al. Interaction of prenatal maternal smoking, interleukin 13 genetic variants and DNA methylation influencing airflow and airway reactivity. *Clin Epigenetics* 2013;5:22.
98. Ramasamy A, Kuokkanen M, Vedantam S, Gajdos ZK, Couto Alves A, Lyon HN, et al. Genome-wide association studies of asthma in population-based cohorts confirm known and suggested loci and identify an additional association near HLA. *PLoS ONE* 2012;7:e44008.
99. Schmitz J, Owyang A, Oldham E, Song Y, Murphy E, McClanahan TK, et al. IL-33, an interleukin-1-like cytokine that signals via the IL-1 receptor-related protein ST2 and induces T helper type 2-associated cytokines. *Immunity* 2005;23:479–90.
100. Moffatt MF, Gut IG, Demenais F, Strachan DP, Bouzigon E, Heath S, et al. A large-scale, consortium-based genomewide association study of asthma. *N Engl J Med* 2010;363:1211–21.
101. Torgerson DG, Ampleford EJ, Chiu GY, Gauderman WJ, Gignoux CR, Graves PE, et al. Meta-analysis of genome-wide association

- studies of asthma in ethnically diverse North American populations. *Nat Genet* 2011;43:887–92.
102. Grotenboer NS, Ketelaar ME, Koppelman GH, Nawjin MC. Decoding asthma: translating genetic variation in IL33 and IL1RL1 into disease pathophysiology. *J Allergy Clin Immunol* 2013;131:856–65.
  103. Spits H, Di Santo JP. The expanding family of innate lymphoid cells: regulators and effectors of immunity and tissue remodeling. *Nat Immunol* 2011;12:21–7.
  104. Murphy A, Chu J-H, Xu M, Carey VJ, Lazarus R, Liu A, et al. Mapping of numerous disease-associated expression polymorphisms in primary peripheral blood CD4+ lymphocytes. *Hum Mol Genet* 2010;19:4745–57.
  105. Kabesch M, Schedel M, Carr D, Woitsch B, Fritsch C, Weiland SK, et al. IL-4/IL-13 pathway genetics strongly influence serum IgE levels and childhood asthma. *J Allergy Clin Immunol* 2006;117:269–74.
  106. Battle NC, Choudhry S, Tsai HJ, Eng C, Kumar G, Beckman KB, et al. Ethnicity-specific gene-gene interaction between IL-13 and IL-4R alpha among African Americans with asthma. *Am J Respir Crit Care Med* 2007;175:881–7.
  107. Hunninghake GM, Soto-Quiros ME, Avila L, Su J, Murphy A, Demeo DL, et al. Polymorphisms in IL13, total IgE, eosinophilia, and asthma exacerbations in childhood. *J Allergy Clin Immunol* 2007;120:84–90.
  108. Presland RB, Coulombe PA, Eckert RL, Mao-Qiang M, Feingold KR, Elias PM. Barrier function in transgenic mice overexpressing K16, involucrin, and filaggrin in the suprabasal epidermis. *J Invest Dermatol* 2004;123:603–6.
  109. Compton JG, DiGiovanna JJ, Johnston KA, Fleckman P, Bale SJ. Mapping of the associated phenotype of an absent granular layer in ichthyosis vulgaris to the epidermal differentiation complex on chromosome 1. *Exp Dermatol* 2002;11:518–26.
  110. Smith FJ, Irvine AD, Terron-Kwiatkowski A, Sandilands A, Campbell LE, Zhao Y, et al. Loss-of-function mutations in the gene encoding filaggrin cause ichthyosis vulgaris. *Nat Genet* 2006;38:337–42.
  111. Brown SJ, McLean WH. Eczema genetics: current state of knowledge and future goals. *J Invest Dermatol* 2009;129:543–52.
  112. Palmer CN, Irvine AD, Terron-Kwiatkowski A, Zhao Y, Liao H, Lee SP, et al. Common loss-of-function variants of the epidermal barrier protein filaggrin are a major predisposing factor for atopic dermatitis. *Nat Genet* 2006;38:441–6.
  113. Sandilands A, O'Regan GM, Liao H, Zhao Y, Terron-Kwiatkowski A, Watson RM, et al. Prevalent and rare mutations in the gene encoding filaggrin cause ichthyosis vulgaris and predispose individuals to atopic dermatitis. *J Invest Dermatol* 2006;126:1770–5.
  114. Barker JN, Palmer CN, Zhao Y, Liao H, Hull PR, Lee SP, et al. Null mutations in the filaggrin gene (FLG) determine major susceptibility to early-onset atopic dermatitis that persists into adulthood. *J Invest Dermatol* 2007;127:564–7.
  115. Weidinger S, Illig T, Baurecht H, Irvine AD, Rodriguez E, Diaz-Lacava A, et al. Loss-of-function variations within the filaggrin gene predispose for atopic dermatitis with allergic sensitizations. *J Allergy Clin Immunol* 2006;118:214–19.
  116. Palmer CN, Ismail T, Lee SP, Terron-Kwiatkowski A, Zhao Y, Liao H, et al. Filaggrin null mutations are associated with increased asthma severity in children and young adults. *J Allergy Clin Immunol* 2007;120:64–8.
  117. Marenholz I, Nickel R, Ruschendorf F, Schulz F, Esparza-Gordillo J, Kerscher T, et al. Filaggrin loss-of-function mutations predispose to phenotypes involved in the atopic march. *J Allergy Clin Immunol* 2006;118:866–71.
  118. Vercelli D. Of flaky tails and itchy skin. *Nat Genet* 2009;41:512–13.
  119. Fallon PG, Sasaki T, Sandilands A, Campbell LE, Saunders SP, Mangani NE, et al. A homozygous frameshift mutation in the mouse Flg gene facilitates enhanced percutaneous allergen priming. *Nat Genet* 2009;41:602–8.
  120. Contopoulos-Ioannidis DG, Manoli EN, Ioannidis JP. Meta-analysis of the association of beta2-adrenergic receptor polymorphisms with asthma phenotypes. *J Allergy Clin Immunol* 2005;115:963–72.
  121. Holloway JW, Yang IA. Beta2-Adrenergic receptor polymorphism and asthma: true or false? *J Allergy Clin Immunol* 2005;115:960–2.
  122. Tantisira KG, Silverman ES, Mariani TJ, Xu J, Richter BG, Klanderman BJ, et al. FCER2: a pharmacogenetic basis for severe exacerbations in children with asthma. *J Allergy Clin Immunol* 2007;120:1285–91.
  123. Palmer LJ, Silverman ES, Weiss ST, Drazen JM. Pharmacogenetics of Asthma. *Am J Respir Crit Care Med* 2002;165:861–6.
  124. Malmstrom K, Rodriguez-Gomez G, Guerra J, Villaran C, Pineiro A, Wei LX, et al. Oral montelukast, inhaled beclomethasone, and placebo for chronic asthma: a randomized, controlled trial. Montelukast/Beclomethasone Study Group. *Ann Intern Med* 1999;130:487–95.
  125. Szefer SJ, Phillips BR, Martinez FD, Chinchilli VM, Lemanske RF, Strunk RC, et al. Characterization of within-subject responses to fluticasone and montelukast in childhood asthma. *J Allergy Clin Immunol* 2005;115:233–42.
  126. Hall IP, Sayers I. Pharmacogenetics and asthma: false hope or new dawn? *Eur Respir J* 2007;29:1239–45.
  127. Reihaus E, Innis M, MacIntyre N, Liggett SB. Mutations in the gene encoding for the beta-2-adrenergic receptor in normal and asthmatic subjects. *Am J Respir Cell Mol Biol* 1993;8:334–9.
  128. Tan S, Hall IP, Dewar J, Dow E, Lipworth B. Association between beta 2-adrenoceptor polymorphism and susceptibility to bronchodilator desensitisation in moderately severe stable asthmatics. *Lancet* 1997;350:995–9.
  129. Martinez FD, Graves PE, Baldini M, Solomon S, Erickson R. Association between genetic polymorphisms of the beta2-adrenoceptor and response to albuterol in children with and without a history of wheezing. *J Clin Invest* 1997;100:3184–8.
  130. Green SA, Turki J, Innis M, Liggett SB. Amino-terminal polymorphisms of the human beta 2-adrenergic receptor impart distinct agonist-promoted regulatory properties. *Biochemistry* 1994;33:9414–19.
  131. Green SA, Turki J, Bejarano P, Hall IP, Liggett SB. Influence of beta 2-adrenergic receptor genotypes on signal transduction in human airway smooth muscle cells. *Am J Respir Cell Mol Biol* 1995;13:25–33.
  132. Israel E, Drazen JM, Liggett SB, Boushey HA, Cherniack RM, Chinchilli VM, et al. The effect of polymorphisms of the beta2-adrenergic receptor on the response to regular use of albuterol in asthma. *Am J Respir Crit Care Med* 2000;162:75–80.
  133. Lipworth BJ, Hall IP, Tan S, Aziz I, Coutie W. Effects of genetic polymorphism on ex vivo and in vivo function of beta2-adrenoceptors in asthmatic patients. *Chest* 1999;115:324–8.
  134. Hancox RJ, Sears MR, Taylor DR. Polymorphism of the beta2-adrenoceptor and the response to long-term beta2-agonist therapy in asthma. *Eur Respir J* 1998;11:589–93.
  135. Bleecker ER, Postma DS, Lawrance RM, Meyers DA, Ambrose HJ, Goldman M. Effect of ADRB2 polymorphisms on response to long-acting beta2-agonist therapy: a pharmacogenetic analysis of two randomised studies. *Lancet* 2007;370:2118–25.
  136. Bleecker ER, Yancey SW, Baitinger LA, Edwards LD, Klotsman M, Anderson WH, et al. Salmeterol response is not affected by beta2-adrenergic receptor genotype in subjects with persistent asthma. *J Allergy Clin Immunol* 2006;118:809–16.
  137. Hawkins GA, Weiss ST, Bleecker ER. Clinical consequences of ADRbeta2 polymorphisms. *Pharmacogenomics* 2008;9:349–58.
  138. Litonjua AA, Lasky-Su J, Schneiter K, Tantisira KG, Lazarus R, Klanderman B, et al. ARG1 is a novel bronchodilator response gene: screening and replication in four asthma cohorts. *Am J Respir Crit Care Med* 2008;178:688–94.
  139. Chan MT, Leung DY, Szefer SJ, Spahn JD. Difficult-to-control asthma: clinical characteristics of steroid-insensitive asthma. *J Allergy Clin Immunol* 1998;101:594–601.
  140. Tantisira KG, Small KM, Litonjua AA, Weiss ST, Liggett SB. Molecular properties and pharmacogenetics of a polymorphism of adenylyl cyclase type 9 in asthma: interaction between beta-agonist and corticosteroid pathways. *Hum Mol Genet* 2005;14:1671–7.
  141. Tantisira KG, Lake S, Silverman ES, Palmer LJ, Lazarus R, Silverman EK, et al. Corticosteroid pharmacogenetics: association of sequence variants in CRHR1 with improved lung function in asthmatics treated with inhaled corticosteroids. *Hum Mol Genet* 2004;13:1353–9.
  142. Tantisira KG, Lazarus R, Litonjua AA, Klanderman B, Weiss ST. Chromosome 17: association of a large inversion polymorphism with corticosteroid response in asthma. *Pharmacogenomics* 2008;18:733–7.
  143. Tantisira KG, Hwang ES, Raby BA, Silverman ES, Lake SL, Richter BG, et al. TBX21: a functional variant predicts improvement in asthma with the use of inhaled corticosteroids. *Proc Natl Acad Sci U S A* 2004;101:18099–104.
  144. Hawkins GA, Lazarus R, Smith RS, Tantisira KG, Meyers DA, Peters SP, et al. The glucocorticoid receptor heterocomplex gene STIP1 is associated with improved lung function in asthmatic subjects treated with inhaled corticosteroids. *J Allergy Clin Immunol* 2009;123:1376–83.e7.
  145. Tantisira KG, Lasky-Su J, Harada M, Murphy A, Litonjua AA, Himes BE, et al. Genomewide association between GLCCI1 and response to glucocorticoid therapy in asthma. *N Engl J Med* 2011;365:1173–83.
  146. Tantisira KG, Damask A, Szefer SJ, Schuermann B, Markezich A, Su J, et al. Genome-wide association identifies the T gene as a novel asthma



- pharmacogenetic locus. *Am J Respir Crit Care Med* 2012;185:1286–91.
147. Yim RP, Koumbourlis AC. Steroid-resistant asthma. *Paediatr Respir Rev* 2012;13:172–7.
  148. Fowler SJ, Hall IP, Wilson AM, Wheatley AP, Lipworth BJ. 5-Lipoxygenase polymorphism and in-vivo response to leukotriene receptor antagonists. *Eur J Clin Pharmacol* 2002;58:187–90.
  149. Kanaoka Y, Maekawa A, Austen KF. Identification of GPR99 protein as a potential third cysteinyl leukotriene receptor with a preference for leukotriene E4 ligand. *J Biol Chem* 2013;288:10967–72.
  150. Klotsman M, York TP, Pillai SG, Vargas-Irwin C, Sharma SS, van den Oord EJ, et al. Pharmacogenetics of the 5-lipoxygenase biosynthetic pathway and variable clinical response to montelukast. *Pharmacogenet Genomics* 2007;17:189–96.
  151. Lima JJ, Zhang S, Grant A, Shao L, Tantisira KG, Allayee H, et al. Influence of leukotriene pathway polymorphisms on response to montelukast in asthma. *Am J Respir Crit Care Med* 2006;173:379–85.
  152. Tantisira KG, Lima J, Sylvia J, Klanderman B, Weiss ST. 5-Lipoxygenase pharmacogenetics in asthma: overlap with Cys-leukotriene receptor antagonist loci. *Pharmacogenet Genomics* 2009;19:244–7.
  153. Helgadottir A, Manolescu A, Helgason A, Thorleifsson G, Thorsteinsdottir U, Gudbjartsson DF, et al. A variant of the gene encoding leukotriene A4 hydrolase confers ethnicity-specific risk of myocardial infarction. *Nat Genet* 2006;38:68–74.
  154. Helgadottir A, Manolescu A, Thorleifsson G, Gretarsdottir S, Jonsdottir H, Thorsteinsdottir U, et al. The gene encoding 5-lipoxygenase activating protein confers risk of myocardial infarction and stroke. *Nat Genet* 2004;36:233–9.
  155. Helgadottir A, Gretarsdottir S, St Clair D, Manolescu A, Cheung J, Thorleifsson G, et al. Association between the gene encoding 5-lipoxygenase-activating protein and stroke replicated in a Scottish population. *Am J Hum Genet* 2005;76:505–9.
  156. Dwyer JH, Allayee H, Dwyer KM, Fan J, Wu H, Mar R, et al. Arachidonate 5-lipoxygenase promoter genotype, dietary arachidonic acid, and atherosclerosis. *N Engl J Med* 2004;350:29–37.
  157. Holloway JW, Barton SJ, Holgate ST, Rose-Zerilli MJ, Sayers I. The role of LTA4H and ALOX5AP polymorphism in asthma and allergy susceptibility. *Allergy* 2008;63:1046–53.
  158. Mougey E, Lang JE, Allayee H, Teague WG, Dozor AJ, Wise RA, et al. ALOX5 polymorphism associates with increased leukotriene production and reduced lung function and asthma control in children with poorly controlled asthma. *Clin Exp Allergy* 2013;43:512–20.
  159. Slager RE, Otulana BA, Hawkins GA, Yen YP, Peters SP, Wenzel SE, et al. IL-4 receptor polymorphisms predict reduction in asthma exacerbations during response to an anti-IL-4 receptor  $\alpha$  antagonist. *J Allergy Clin Immunol* 2012;130:516–22.e4.
  160. Pascual M, Suzuki M, Isidoro-Garcia M, Padron J, Turner T, Lorente F, et al. Epigenetic changes in B lymphocytes associated with house dust mite allergic asthma. *Epigenetics* 2011;6:1131–7.
  161. Martino D, Joo JE, Sexton-Oates A, Dang T, Allen K, Saffery R, et al. Epigenome-wide association study reveals longitudinally stable DNA methylation differences in CD4+ T cells from children with IgE-mediated food allergy. *Epigenetics* 2014;9:998–1006.
  162. Jirtle RL, Skinner MK. Environmental epigenomics and disease susceptibility. *Nat Rev Genet* 2007;8:253–62.
  163. Ziyab AH, Karmaus W, Holloway JW, Zhang H, Ewart S, Arshad SH. DNA methylation of the filaggrin gene adds to the risk of eczema associated with loss-of-function variants. *J Eur Acad Dermatol Venereol* 2013;27:e420–3.
  164. Pembrey ME, Bygren LO, Kaati G, Edvinsson S, Northstone K, Sjöström M, et al. The ALSPAC study team. Sex-specific, male-line transgenerational responses in humans. *Eur J Hum Genet* 2006;14:159–66.
  165. Padmanabhan N, Jia D, Geary-Joo C, Wu X, Ferguson-Smith AC, Fung E, et al. Mutation in folate metabolism causes epigenetic instability and transgenerational effects on development. *Cell* 2013;155:81–93.
  166. Li Y, Langholx B, Salam MT, Gilliland FD. Maternal and grandmaternal smoking patterns are associated with early childhood asthma. *Chest* 2005;127:1232–41.
  167. Hollingsworth JW, Maruoka S, Boon K, Garantziotis S, Li Z, Tomfohr J, et al. In utero supplementation with methyl donors enhances allergic airway disease in mice. *J Clin Invest* 2008;118:3462–9.
  168. Miller RL, Ho SM. Environmental epigenetics and asthma: current concepts and call for studies. *Am J Respir Crit Care Med* 2008;177:567–73.
  169. Burke W, Fesinmeyer M, Reed K, Hampson L, Carlsten C. Family history as a predictor of asthma risk. *Am J Prev Med* 2003;24:160–9.
  170. Koppelman GH, te Meerman GJ, Postma DS. Genetic testing for asthma. *Eur Respir J* 2008;32:775–82.
  171. Janssens AC, Aulchenko YS, Elefante S, Borsboom GJ, Steyerberg EW, van Duijn CM. Predictive testing for complex diseases using multiple genes: fact or fiction? *Genet Med* 2006;8:395–400.
  172. Lyssenko V, Jonsson A, Almgren P, Pulizzi N, Isomaa B, Tuomi T, et al. Clinical risk factors, DNA variants, and the development of type 2 diabetes. *N Engl J Med* 2008;359:2220–32.
  173. Meigs JB, Shrader P, Sullivan LM, McAteer JB, Fox CS, Dupuis J, et al. Genotype score in addition to common risk factors for prediction of type 2 diabetes. *N Engl J Med* 2008;359:2208–19.
  174. Narayan KM, Weber MB. Clinical risk factors, DNA variants, and the development of type 2 diabetes. *N Engl J Med* 2009;360:1360, author reply 1.
  175. Holloway JW, Yang IA, Holgate ST. Interpatient variability in rates of asthma progression: can genetics provide an answer? *J Allergy Clin Immunol* 2008;121:573–9.
  176. Holgate ST, Davies DE, Powell RM, Howarth PH, Haitchi HM, Holloway JW. Local genetic and environmental factors in asthma disease pathogenesis: chronicity and persistence mechanisms. *Eur Respir J* 2007;29:793–803.



# Regulation and Biology of Immunoglobulin E

HANS C. OETTGEN

## KEY POINTS

- IgE-producing B cells arise from IgM<sup>+</sup> or IgG<sup>+</sup> B cells via the process of class switch recombination (CSR). B cells undergoing CSR undergo somatic gene rearrangements in the immunoglobulin heavy chain locus leading to the assembly of a gene encoding the  $\epsilon$ -heavy chain retaining the original antigenic specificity of the B cell clone.
- IgE antibody production is regulated by Th2 cells. These provide a combination of signals including secreted cytokine (IL-4 or IL-13) and cell surface molecules (CD40L).
- IgE signaling via Fc $\epsilon$ RI, its high-affinity receptor, on mast cells and basophils by polyvalent antigen leads to the activation of a complex array of signaling pathways resulting in the release of preformed and newly synthesized mediators of immediate hypersensitivity.
- The low-affinity IgE receptor, CD23, mediates IgE-facilitated antigen uptake by antigen-presenting cells, transcellular allergen transport in gastrointestinal and airway epithelium and regulation of IgE production.
- IgE antibodies regulate numerous aspects of hypersensitivity including IgE-receptor density on mast cells and basophils and mast cell homeostasis.

Normally present at very low levels in plasma, antibodies of the immunoglobulin E (IgE) isotype were first discovered in 1967, decades after the description of IgG, IgA and IgM. IgE antibodies are produced primarily by plasma cells in mucosal-associated lymphoid tissue and their levels are uniformly elevated in patients suffering from atopic conditions like asthma, allergic rhinitis and atopic dermatitis. Production of allergen-specific IgE in atopic individuals is driven both by a genetic predisposition to the synthesis of this isotype as well as by environmental factors, including chronic allergen exposure. The lineage commitment by B cells to produce IgE involves irreversible genetic changes at the immunoglobulin heavy chain gene locus and is very tightly regulated. It requires both cytokine signals (interleukin [IL]-4 and IL-13) and interaction of TNF receptor family members on the B cell surface with their ligands.

IgE antibodies exert their biologic functions via the high-affinity IgE receptor, Fc $\epsilon$ RI, and the low-affinity receptor, CD23. In the classic immediate hypersensitivity reaction, the interaction of polyvalent allergens with IgE bound to mast cells via Fc $\epsilon$ RI triggers receptor aggregation, which initiates a series of signals that result in the release of vasoactive and chemotactic mediators of acute tissue inflammation. Clinical manifestations

of IgE-induced immediate hypersensitivity include systemic anaphylaxis (triggered by foods, drugs and insect stings), bronchial edema with smooth muscle constriction and acute airflow obstruction in asthmatic patients (following allergen inhalation), angioedema and urticaria. Although best known for their critical function in mediating antigen-specific immediate hypersensitivity reactions, IgE antibodies also exert potent immunoregulatory effects including regulation of mast cell homeostasis, stabilization of IgE receptor expression and enhancement of mast cell-mediated expansion of Th2 responses and suppression of T<sub>REG</sub> responses to allergens.

## Components of the Immune Response

### IMMUNOGLOBULIN E PROTEIN STRUCTURE AND GENE ORGANIZATION

Immunoglobulin E (IgE) antibodies are tetramers consisting of two light chains ( $\kappa$  or  $\lambda$ ) and two  $\epsilon$ -heavy chains (Figure 4-1 and Box 4-1). The heavy chains each contain a variable ( $V_H$ ) region and four constant region domains. The  $V_H$  domain, together with the V-regions of the light chains ( $V_L$ ), confers antibody specificity and the C $\epsilon$  domains confer isotype-specific functions, including interaction with Fc $\epsilon$ RI and CD23. IgE antibodies are heavily glycosylated and contain numerous intrachain and interchain disulfide bonds. The exons encoding the  $\epsilon$ -heavy chain domains are located in the C $\epsilon$  locus near the 3' end of the immunoglobulin heavy chain locus (IgH) (Figure 4-2).<sup>1</sup> Additional exons, M1 and M2, encode hydrophobic sequences present in the  $\epsilon$ -heavy chain mRNA splice isoforms encoding transmembrane IgE in IgE<sup>+</sup> B cells. In contrast to IgG antibodies, which have a half-life of about 3 weeks, IgE antibodies are very short-lived in plasma ( $T_{1/2}$  less than 1 day), but they can remain fixed to mast cells in tissues for weeks or months.

The assembly of a functional IgE gene requires two sequential processes of DNA excision and ligation.<sup>2,3</sup> In the first, which occurs in pre-B cells, individual  $V_H$ , D, and  $J_H$  exons randomly combine to generate a  $V_HDJ_H$  cassette encoding an antigen-specific  $V_H$  domain. In B cells that have undergone 'productive'  $V_HDJ_H$  rearrangements (e.g. no stop codons have been introduced during assembly), this  $V_HDJ_H$  cassette is situated just upstream of the C $\mu$  and C $\delta$  exons so that functional  $\mu$ - and  $\delta$ -heavy chain transcripts can be produced.

A second DNA excision and ligation process, called *class switch recombination* (CSR), must occur before B cells can produce antibodies of other isotypes, including IgE. These antibodies retain their original  $V_HDJ_H$  cassette and antigenic specificity but exchange C $_H$  cassettes of various isotypes to construct

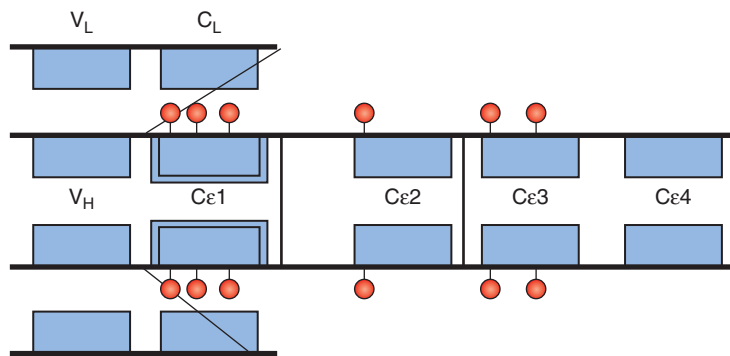

**Figure 4-1** IgE antibody structure. IgE antibodies are tetramers containing two immunoglobulin light chains and two immunoglobulin  $\epsilon$ -heavy chains connected by interchain disulfide bonds as indicated. Each light chain contains one  $V_L$  and one  $C_L$  immunoglobulin domain and each  $\epsilon$ -heavy chain contains an N-terminal  $V_H$  domain and four  $C_\epsilon$  domains. Intrachain disulfide bonds are contained within each of these immunoglobulin domains. The  $C_\epsilon$  domains contain IgE isotype-specific sequences important for interactions with IgE receptors Fc $\epsilon$ R1 and CD23. IgE antibodies are relatively heavily glycosylated; glycosylation sites are indicated with circles.

### BOX 4-1 KEY CONCEPTS

#### Components of the Immune Response

#### IgE ANTIBODIES, GENES AND RECEPTORS

- IgE structure      IgE protein  
IgE gene arrangement
- IgE class-switch recombination      Germline transcription  
Structure of the  $I\epsilon$  promoter  
Cytokine regulation of germline transcription  
CD40/CD154 signaling  
TACI/BAFF signaling  
Activation-induced cytidine deaminase  
DNA double strand breaks and repair
- IgE receptors      Fc $\epsilon$ R1  
CD23

different heavy chains that exert distinct biologic functions. In this tightly regulated and irreversible process, sometimes referred to as deletional switch recombination, a long stretch of genomic DNA spanning from the  $S\mu$  region between  $V_HDJ_H$  and  $C\mu$  to  $S\epsilon$  upstream of the  $C_\epsilon$  locus is excised (see Figure 4-2). The DNA products of this reaction include an extrachromosomal circle of intervening DNA and the contiguous  $V_HDJ_H$  and  $C_\epsilon$  sequences, joined by  $S\mu$ - $S\epsilon$  ligation, to generate a functional IgE gene. A complex series of cytokine signals and cell surface interactions collaborate to trigger deletional switch recombination in B cells destined for IgE production.

## REGULATION OF IgE ISOTYPE SWITCHING

### $\epsilon$ -Germline Transcription Precedes Isotype Switch Recombination

Before deletional isotype switch recombination is initiated, cytokine signals provided by IL-4 and/or IL-13 induce RNA transcription in the IgH locus of B cells. This occurs at the unrearranged or 'germline'  $\epsilon$ -heavy chain locus driven from a promoter 5' of the  $I\epsilon$  exon, located just upstream of the  $S\epsilon$  switch recombination region and the four  $C_\epsilon$  exons (Figure 4-3). This is referred to as  $\epsilon$ -germline RNA and the transcripts include a 140-bp  $I\epsilon$  exon as well as exons  $C_\epsilon 1$ - $C_\epsilon 4$ .<sup>4,5</sup> As  $I\epsilon$

contains several stop codons, germline transcripts do not encode functional proteins and have been referred to as 'sterile'.<sup>6</sup>

### Regulation of Germline Transcription, The $I\epsilon$ Promoter

Initiation of germline transcription is regulated by the  $I\epsilon$  promoter that contains binding sites for several known transcription factors including STAT-6, NF- $\kappa$ B, BSAP (Pax5), C/EBP and PU.1 (see Figure 4-3). Accessibility of the promoter is regulated by the non-histone chromosomal protein, HMG-I(Y).<sup>7</sup> This repression is released upon IL-4-driven phosphorylation of the protein.<sup>8,9</sup> Translocation of activated STAT-6 to the nucleus is triggered by IL-4 and IL-13 signaling. STAT-6 activation appears to be the key inducible regulator of  $\epsilon$ -germline transcription; neither BSAP nor NF- $\kappa$ B nuclear-binding activities are altered by cytokine signaling, but these promoter elements must be present for normal  $I\epsilon$  promoter function.<sup>10,11</sup> CD40 signaling also enhances cytokine-driven germline transcription by activating the NF- $\kappa$ B promoter elements.

BCL-6, a POZ/zinc-finger transcription factor expressed in B cells, is an important negative regulator of the  $I\epsilon$  promoter. BCL-6 binds to STAT-6 sites and can repress the induction of  $\epsilon$ -germline transcripts by IL-4.<sup>12,13</sup> BCL-6 is induced by the cytokine, IL-21, which is known to suppress IgE production in B cells and which has been reported to induce apoptosis of IgE<sup>+</sup> B cells.<sup>14</sup> IL-21 is important in germinal center formation and germinal centers have relatively low levels of IgE production.<sup>14,15</sup>

### Cytokines IL-4 and IL-13 Activate STAT-6

The cytokines IL-4 and IL-13 are potent inducers of  $\epsilon$ -germline transcription in B cells.<sup>5,16,17</sup> The multimeric receptors for these two cytokines share the IL-4R- $\alpha$  chain. The type I IL-4 receptor, which binds IL-4, is composed of the ligand-binding IL-4R $\alpha$  and the signal-transducing common cytokine receptor  $\gamma$ -chain  $\gamma_c$ . The type II receptor, which can bind either IL-4 or IL-13, contains the IL-4R- $\alpha$  chain along with an IL-13 binding chain, IL-13R $\alpha 1$ . IL-4 receptor signaling triggers the activation of Janus family tyrosine kinases Jak-1 (via IL-4R $\alpha$ ), Jak-3 (via  $\gamma_c$ ) and TYK2 (via IL-13R $\alpha$ ).<sup>18-21</sup> These activated Jaks then phosphorylate tyrosine residues in the intracellular domains of the receptor chain. These phosphotyrosines serve as binding sites

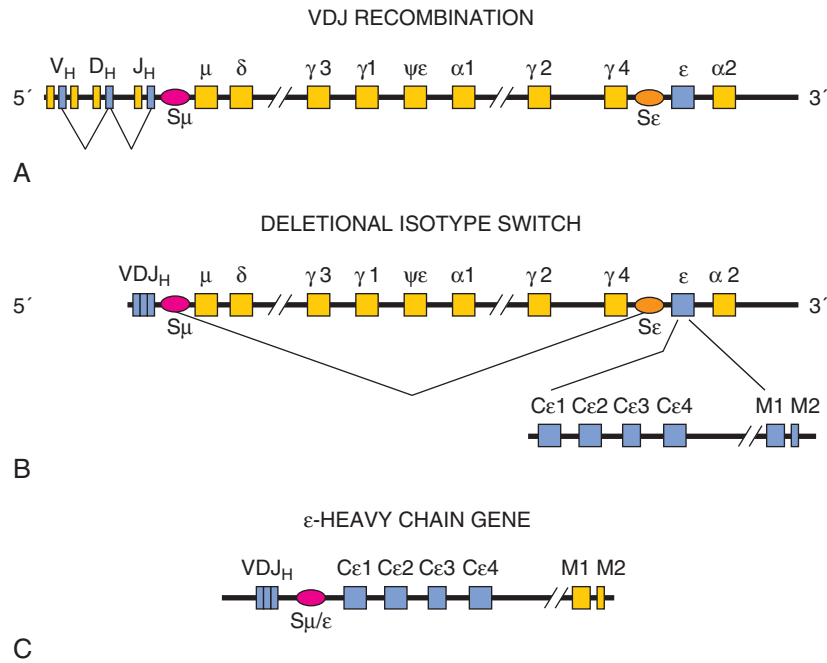

**Figure 4-2** The human immunoglobulin heavy chain gene locus; deletional class-switch recombination. (A) The human immunoglobulin heavy chain locus contains clusters of  $V_H$ ,  $D_H$  and  $J_H$  cassettes that are stochastically rearranged during B cell ontogeny. This process, which involves DNA excision and repair, results in the assembly of a complete VDJ exon encoding an antigen-binding  $V_H$  domain. Pre-B cells that have completed this rearrangement are capable of producing intact  $\mu$ -heavy chains and, following an analogous process of light chain rearrangements, can produce intact IgM antibodies. (B) Production of other antibody isotypes, bearing the original antigenic specificity, requires an additional excision and repair process, deletional 'class-switch recombination' (CSR). For IgE isotype switching, this process involves the excision of a large piece of genomic DNA spanning from  $S_\mu$  switch sequences just upstream of the  $\mu$ -heavy chain exons to the  $S_\epsilon$  sequence 5' of the  $C_\epsilon$  exons. (C) Ligation of the VDJ sequences to the  $C_\epsilon$  locus then gives rise to an intact  $\epsilon$ -heavy chain gene containing a  $V_H$ -encoding VDJ exon and exons  $C_\epsilon 1-4$  encoding the constant region domains of  $\epsilon$ -heavy chain. The M1 and M2 exons encode trans-membrane sequences that are present in RNA splice isoforms encoding the membrane IgE of IgE<sup>+</sup> B cells.

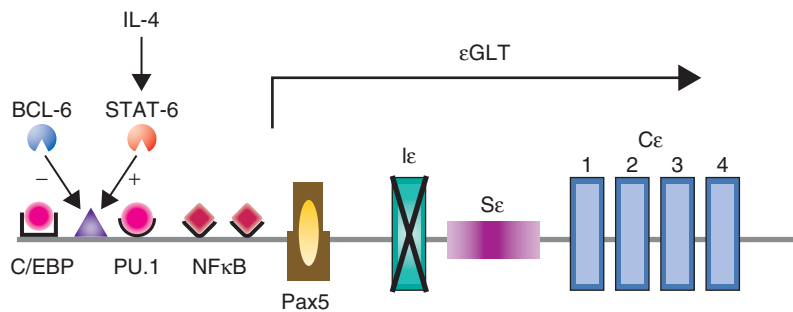

**Figure 4-3**  $\epsilon$ -Germline transcription ( $\epsilon$ GLT). Class switch recombination is invariably preceded by a process of RNA transcription at the  $C_H$  locus being targeted by specific cytokine signals.  $\epsilon$ -Germline transcripts originate at a promoter upstream of the  $I_\epsilon$  exon. This promoter contains binding sites for transcription factors C/EBP, PU.1, STAT-6, NF- $\kappa$ B (two sites), and Pax5. STAT-6 activation is triggered by IL-4 and IL-13 receptor signaling and is the critical regulatory factor in  $\epsilon$ -germline transcription. BCL-6 is a transcriptional repressor that binds to the STAT-6 target site and inhibits  $\epsilon$ GLT. Germline transcripts contain  $I_\epsilon$  and  $C_\epsilon 1-4$  exons but, because the  $I_\epsilon$  exon contains stop codons ('X'), these RNAs do not encode a functional protein.

for STAT-6, which is, in turn, phosphorylated and then dimerizes and translocates to the nucleus.<sup>22,23</sup>

#### CD40/CD154 Provides Second Signal for Isotype Switch Recombination

The cytokines IL-4 and IL-13 are very efficient inducers of  $\epsilon$ -germline transcription, and this transcription is an absolute prerequisite for isotype switching. However, cytokine-induced germline transcription alone is not sufficient to drive B cells to complete the genomic deletional switch recombination reaction that gives rise to a functional IgE gene. A second signal, provided by the interaction of the TNF receptor family member

CD40 on B cells with its ligand, CD154, on activated T cells, is required to bring the process to completion.

CD154 is transiently expressed on antigen/MCH-stimulated T cells.<sup>24</sup> T cell CD154 induces CD40 aggregation on B cells, triggering signal transduction via four intracellular proteins belonging to the TRAF family of TNF-receptor associated factors.<sup>25,26</sup> TRAF-2, -5, and -6 promote the dissociation of NF- $\kappa$ B from its inhibitor, I $\kappa$ B, allowing NF- $\kappa$ B to translocate to the nucleus and synergize with STAT-6 to activate the  $I_\epsilon$  promoter as described above.<sup>27,28</sup> In addition to inducing TRAF association and signaling, aggregation of CD40 activates protein tyrosine kinases (PTKs) including Jak-3, which play an

important role in immunoglobulin class switching.<sup>29,30</sup> CD154 is encoded on the X chromosome. Boys with X-linked immunodeficiency with hyper-IgM (XHIM) are deficient in CD154. Consequently, their B cells are unable to produce IgG, IgA or IgE.<sup>31-35</sup>

**Alternative Second Signals for Isotype Switch Recombination**

Recently, alternative switching pathways have been defined in which the second ‘switch’ signal is provided not by CD40/CD154 ligation but rather by interaction of other TNF-like molecules with their receptors. One such TNF family member, BAFF, binds to its receptor TACI on cytokine-stimulated B cells, inducing isotype switching even in the absence of CD40.<sup>36,37</sup> BAFF/TACI-driven switching may be of particular importance at mucosal sites, especially IgA production in the gastrointestinal tract. Defects in this pathway underlie some cases of IgA deficiency.<sup>38,39</sup> Although BAFF can drive IgE switching, its physiologic relevance in IgE regulation remains to be clarified. It has been reported that respiratory epithelium produces BAFF, with elevations of the factor in bronchoalveolar lavage fluid (BAL) of segmental allergen-challenged subjects.<sup>40,41</sup> In addition, it has

been demonstrated that IgE class switch recombination occurs not only in central lymphoid organs but also in the respiratory mucosa of patients with allergic rhinitis and asthma.<sup>42</sup>

**Cytokine-Stimulated Germline Transcripts and CD40-Induced AID Collaborate to Execute Switch Recombination**

Deletional class switch recombination stimulated by cytokines and CD40/CD154 requires the synthesis of a new intracellular protein, activation-induced cytidine deaminase (AID), which is expressed in activated splenic B cells and in the germinal centers of lymph nodes.<sup>43,44</sup> AID-deficient mice have elevated IgM levels and a major defect in isotype switching with absent IgG, IgE and IgA. A rare autosomal form of hyper-IgM syndrome (HIGM2), which is associated with striking lymphoid hypertrophy, has now been attributed to mutations in the AID gene.<sup>45</sup>

AID is recruited to sites of active germline transcription where it deaminates deoxy-cytidine residues within the C-rich S $\mu$  and S $\epsilon$  sequences, generating uracils and consequent U:G mismatches (see Figure 4-4).<sup>46,47</sup> Subsequent removal of these uracils by the enzyme uracil glycosylase (UNG) results in the introduction of abasic sites. The enzyme apurinic/apyrimidinic

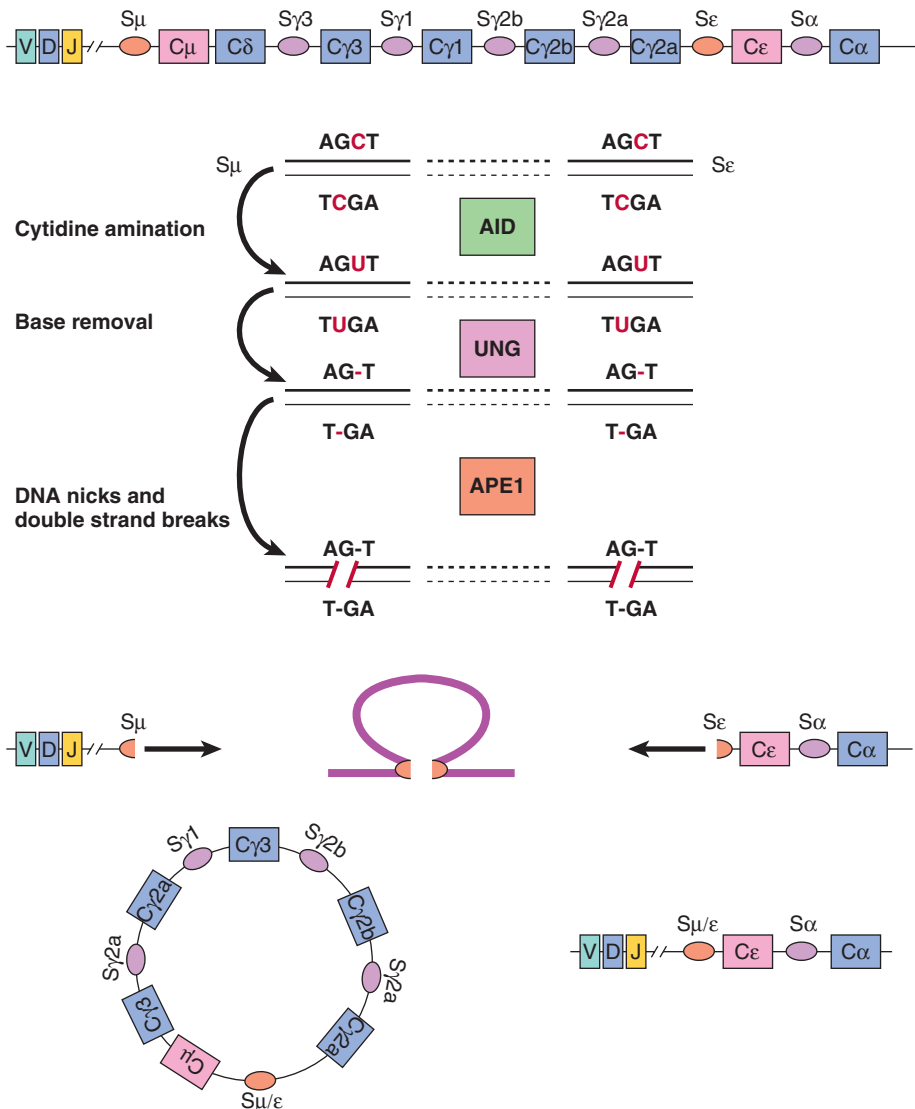

**Figure 4-4** Activation-induced cytidine deaminase (AID) is recruited to sites of cytokine-driven germline transcription (S $\mu$  and S $\epsilon$ ) in the IgH locus where it catalyzes cytidine deamination to uracil. Uracil glycosylase (UNG) introduces abasic sites which are then converted to nicks by apurinic/apyrimidinic endonuclease 1 (APE1). Subsequent double strand DNA breaks followed by end joining of the S $\mu$  and S $\epsilon$  sequences leads to the generation of an intact VDJ-C $\epsilon$ -1-4  $\epsilon$ -heavy chain gene along with an excised episomal DNA circle containing the intervening sequences.



endonuclease 1, APE1, generates nicks at these sites which ultimately lead to double-stranded DNA breaks. In subsequent steps of the process, analogous breaks, located at  $S\mu$  between  $V_HDJ_H$  and the  $C\mu$  exons, are annealed to generate a functional IgE gene. The heterogeneous nature of the  $S\mu$ - $S\epsilon$  junctions suggests a nonhomologous end-joining mechanism such as would be generated by the DNA repair enzymes, Ku70, Ku80 and DNA-PKcs. Consistent with this possibility, B cells lacking Ku70, Ku80 and DNA-PKcs, all of which are involved in non-homologous end joining, cannot execute isotype switching normally.<sup>48,49</sup>

## REGULATION OF ALLERGEN-SPECIFIC T CELL RESPONSES

The execution of IgE isotype switch recombination in B cells, as detailed previously, requires that cytokine (IL-4 and IL-13) signals and the CD40 ligand, CD154 signal, be delivered in a coordinated fashion. Both these stimuli are provided by Th2-type allergen-specific T-helper cells. Thus, the mechanisms that regulate expansion and survival of Th2 cells are crucial in regulating IgE responses.

### Th2 Helper T Cell Development

Naïve  $CD4^+$  Th cells have the capacity to differentiate into a number of distinct types of effector helper, each with distinct capacities for induction of cellular immune responses (Th1), antibody production and allergic responses (Th2), inflammatory responses (Th17) and regulation ( $T_{REG}$ , see Figure 4-5). These Th types are further characterized by the expression of specific transcription factors that maintain their specific lineage commitments and direct their respective cytokine transcription

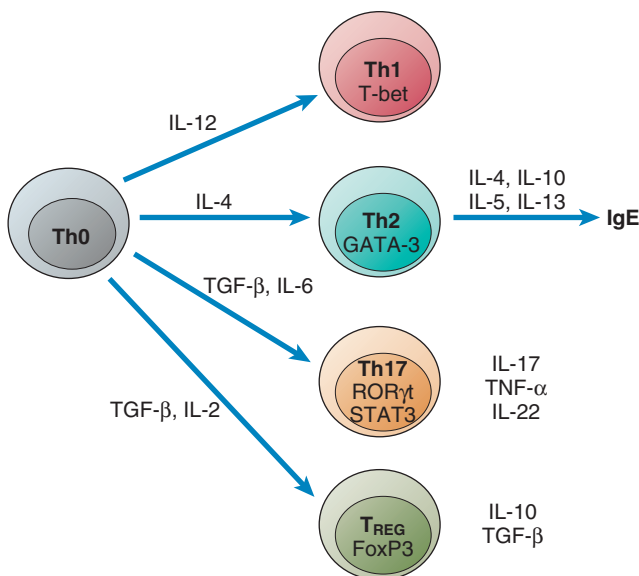

**Figure 4-5**  $CD4^+$  T-helper cell differentiation.  $CD4^+$  T-helper cells undergo a process of differentiation to Th1 (producing IL-2, IFN- $\gamma$  and TNF- $\alpha$ ), Th2 (producing IL-4, IL-5, IL-6, IL-9, IL-10, IL-13 and GM-CSF), Th17 (producing IL-17, TNF- $\alpha$  and IL-22) and  $T_{REG}$  (producing IL-10 and TGF- $\beta$ ) phenotypes. Each lineage is further characterized by the presence of specific transcription factors (as indicated in the nuclei). The critical regulator of IgE production is the Th2 lineage which uniquely produces IL-4.

profiles (Chapter 5). Some of the Th lineages can be identified by specific cell surface markers. Th1 cells, which arise under the direction of IL-12 or IL-18, express abundant IFN- $\gamma$  and IL-2 and are important in immunity to intracellular pathogens. Th1 cells are further characterized by the presence of the transcription factor, T-bet. The Th17 subset is induced in the presence of TGF- $\beta$  and IL-6 and produces IL-17, TNF- $\alpha$  and IL-1. Th17 cells harbor the transcription factors ROR $\gamma$ t and STAT3 and are important in driving neutrophil recruitment and inflammatory responses. As their name implies,  $T_{REG}$ , which are generated in the presence of TGF- $\beta$  and IL-2 (absent IL-6), are important in controlling immune responses via immunosuppressive cytokines including TGF- $\beta$  and IL-10. The transcription factor associated with this lineage is FoxP3.

The critical Th cells promoting IgE production are Th2, which are induced by IL-4, express the transcription factor GATA-3 and produce IL-4, IL-5, IL-6, IL-9, IL-10, IL-13 and GM-CSF. Th2 cells express cell surface receptors, which target their trafficking to allergic sites and trigger activation in settings of allergic inflammation, including the chemokine receptors CCR3, CCR4, CRTh2 and CCR8 and the IL-33 receptor, T1/ST2.<sup>50-53</sup>

### Genetic Influences on Th2 Development

Both host and environmental factors promote the Th2 shift observed in allergic individuals. Genetic predispositions toward Th1 or Th2 are partly accounted for by T cell autonomous tendencies to transcribe Th1 versus Th2 cytokines, but are also the result of a wide range of influences external to T cells.<sup>54</sup> Perhaps the most potent Th1/Th2-polarizing effect is exerted by the cytokine milieu, particularly tissue levels of IL-4, IL-12 and IFN- $\gamma$ . IL-4 promotes Th2 responses and suppresses Th1 development. IL-12 drives Th1 differentiation (an effect that is greatly potentiated by the presence of IFN- $\gamma$ ) and can inhibit and even reverse Th2 development. In ongoing immune responses these cytokines can be provided by existing T cells already committed to a particular Th phenotype. In de novo allergen encounters, cytokines produced by cells of the 'innate' immune response may tip the balance.

### Antigen-Presenting Cell Function in Th Differentiation

Naïve T cells initially encounter antigens as MHC-bound processed peptides on the surface of antigen-presenting cells (APCs). The most potent APCs are dendritic cells (DCs), which reside in tissues as immature sentinels and sample antigens in their milieu. Upon activation, these cells acquire mature APC function and migrate to regional lymphoid tissues, where they efficiently activate antigen-specific T helper cells via MHC-peptide complexes. Dendritic cells obtained from various lymphoid tissues in vivo or cultured ex vivo under a range of conditions all express MHC II and, following activation, express costimulatory molecules, including CD80/86. However, there is some functional heterogeneity among DCs, especially with respect to the ability to induce Th1 versus Th2 T helper responses.<sup>55</sup> DC-derived IL-12 drives Th1 responses; IL-23, TGF- $\beta$  and IL-6 support Th17 induction; and IL-10 drives both  $T_{REG}$  and Th2.<sup>56</sup>

### Microbial Products and Dendritic Cell Phenotype

The recent understanding that Th polarity may be determined by DC polarity obviously begs the following question: what

determines DC polarity? IFN- $\gamma$  favors DC1 development, whereas histamine and PGE<sub>2</sub> promote the development of DC2.<sup>57-59</sup> IL-10 may negatively regulate DC production of IL-12.<sup>60</sup> Conserved microbial structures, which signal via the Toll-like receptor (TLR) family of receptors, can shift DC polarity. Dendritic cells express a range of TLR and the specific effects of ligand binding by each of these receptors on DC phenotype remain to be fully elucidated. The default state of mucosal DC appears to be skewed toward Th2 induction with relatively low basal IL-12 and constitutive production of IL-10.<sup>61</sup>

#### **Non-T Cell Sources of IL-4: Mast Cells, Basophils, NKT Cells and NK Cells**

Although allergen-specific T-helper cells committed to the Th2 lineage are a major source of IL-4 in allergic tissues and may predominate during chronic or memory responses to allergen, several other cell types can provide IL-4 and IL-13 and may be more important in initial allergen encounters. Mast cells, which are abundant in the respiratory and gastrointestinal mucosa, are excellent producers of both IL-4 and IL-13 following activation via IgE/Fc $\epsilon$ RI.<sup>62,63</sup> IgE-stimulated mast cells appear to be a key early source of IL-4 in Th2-dominant immune responses to food allergens.<sup>64</sup> Basophils are rapidly induced in response to allergens or parasites and constitutively produce large quantities of IL-4. NK1.1<sup>+</sup> CD4<sup>+</sup> T (NKT) cells are another source of IL-4. These cells express a very restricted repertoire of  $\alpha\beta$  T cell receptors and interact with the non-classical MHC class I molecule, CD1.<sup>65</sup> The intravenous injection of anti-CD3 in mice induces large amounts of IL-4, derived primarily from these NKT cells. Another recently identified cytokine-producing cell of the innate immune system, the innate lymphoid cell type-2 (ILC2), is commonly found at mucosal sites where its expansion is stimulated by the epithelial cell cytokines, IL-25 and IL-33.<sup>66</sup> The ILC2 lineage is stabilized by the transcription factor ROR $\alpha$ , and secretes IL-4, IL-13 and IL-5.

#### **Sites of IgE Class Switch Recombination and Mechanisms of IgE Memory**

Studies of IgG production in mice have revealed that high-affinity antibody responses arise in germinal centers of secondary lymphoid tissues in which IgM<sup>+</sup> B cells are driven by cytokine signals and costimulatory molecules from T follicular helper cells (T<sub>FH</sub>) to switch to IgG ( $\mu$ - $\gamma$  switch), followed by affinity maturation and generation of long-lived memory B cells. IgE responses may also be induced in germinal centers via direct IgM-IgE switching ( $\mu$ - $\epsilon$ ), but several lines of evidence suggest that affinity maturation is optimized in B cells that have sequentially undergone  $\mu$ - $\gamma$ , and then  $\gamma$ - $\epsilon$  switches and that memory resides in the intermediate IgG<sup>+</sup> B cell compartment. IgE<sup>+</sup> B cells are short-lived in germinal centers, possibly because of rapid transition to plasma cells. Early, low-affinity IgE responses may arise at extrafollicular sites including in the respiratory and gastrointestinal mucosa where the presence of  $\epsilon$  germline transcripts and switch excision circles (Figure 4-4) is readily detected, especially following allergen exposure. Mice unable to generate germinal centers (including BCL-6<sup>-/-</sup> and MHC II-deficient mice) are capable of producing abundant IgE. The current understanding of IgE synthesis gleaned from these observations is that early low-affinity IgE responses arise in mucosal sites, but that affinity maturation and memory are optimized in germinal centers.<sup>67,68</sup>

## **IgE RECEPTORS**

### **Fc $\epsilon$ RI Structure**

The high-affinity IgE receptor Fc $\epsilon$ RI is a multimeric complex expressed in two isoforms, a tetrameric  $\alpha\beta\gamma_2$  receptor present on mast cells and basophils and a trimeric  $\alpha\gamma_2$  receptor expressed, albeit at levels 10-fold to 100-fold lower, by several cell lineages including eosinophils, platelets, monocytes, dendritic cells and cutaneous Langerhans cells<sup>69</sup> (Figure 4-6). The  $\alpha$  chain contains two extracellular immunoglobulin-related domains and is responsible for binding IgE. The  $\beta$  subunit of the receptor contains four transmembrane-spanning domains with both N- and C-terminal ends on the cytosolic side of the plasma membrane. Fc $\epsilon$ RI- $\beta$  appears to have two functions that result in enhanced receptor activity.  $\beta$ -chain expression both enhances cell surface density of Fc $\epsilon$ RI and amplifies the signal transduced following activation of the receptor by IgE aggregation.<sup>69-72</sup> The  $\gamma$  chains (which have homology to the  $\zeta$  and  $\eta$  chains important in T cell receptor signaling) exist as disulfide-linked dimers with trans-membrane domains and cytoplasmic tails. The  $\beta$  and  $\gamma$  chains perform critical signal transduction functions and their intracellular domains contain immunoreceptor tyrosine-based activation motifs (ITAMs), 18 amino acid long tyrosine-containing sequences that constitute docking sites for SH2 domain-containing signaling proteins.

### **CD23 Expression and Structure**

Although its common designation as the 'low-affinity' IgE receptor implies differently, CD23 actually has a fairly high affinity for IgE with a K<sub>A</sub> of about 10<sup>8</sup>.<sup>73,74</sup> A wide variety of cell types express CD23 in humans, including B cells, Langerhans cells, follicular dendritic cells, T cells and eosinophils.<sup>75</sup> It is a type II transmembrane protein with a C-type lectin domain, making it the only immunoglobulin receptor that is not in the Ig superfamily.<sup>76-78</sup> Adjacent to its lectin domain, CD23 has sequences that are predicted to give rise to  $\alpha$ -helical coiled-coil stalks (Figure 4-7). As a result, CD23 is known to have a tendency to multimerize and only oligomeric CD23 will bind IgE.<sup>79</sup> CD23 has homology to the asialoglycoprotein receptor, suggesting a role for CD23 in endocytosis. In addition to binding IgE, CD23 binds to a second ligand, the B cell surface molecule, CD21.<sup>80,81</sup>

## **Principles of IgE-Mediated Disease Mechanisms**

Once produced, allergen-specific IgE antibodies engage their receptors and trigger a wide variety of tissue-specific responses. The cellular and molecular mechanisms of pathogenesis giving rise to specific allergic disorders are presented in great detail in Chapters 24–58. This section will provide a general overview of the consequences of IgE interaction with its receptors, including immediate hypersensitivity, late-phase reactions, regulation of IgE receptor expression and immune modulation (Box 4-2).

## **MAST CELL ACTIVATION AND HOMEOSTASIS**

### **Fc $\epsilon$ RI Signaling**

Fc $\epsilon$ RI has high affinity for IgE (K<sub>d</sub> 10<sup>-8</sup> M) and under physiologic conditions mast cell and basophil Fc $\epsilon$ RI is fully occupied by IgE antibodies. Aggregation of this receptor-bound IgE by

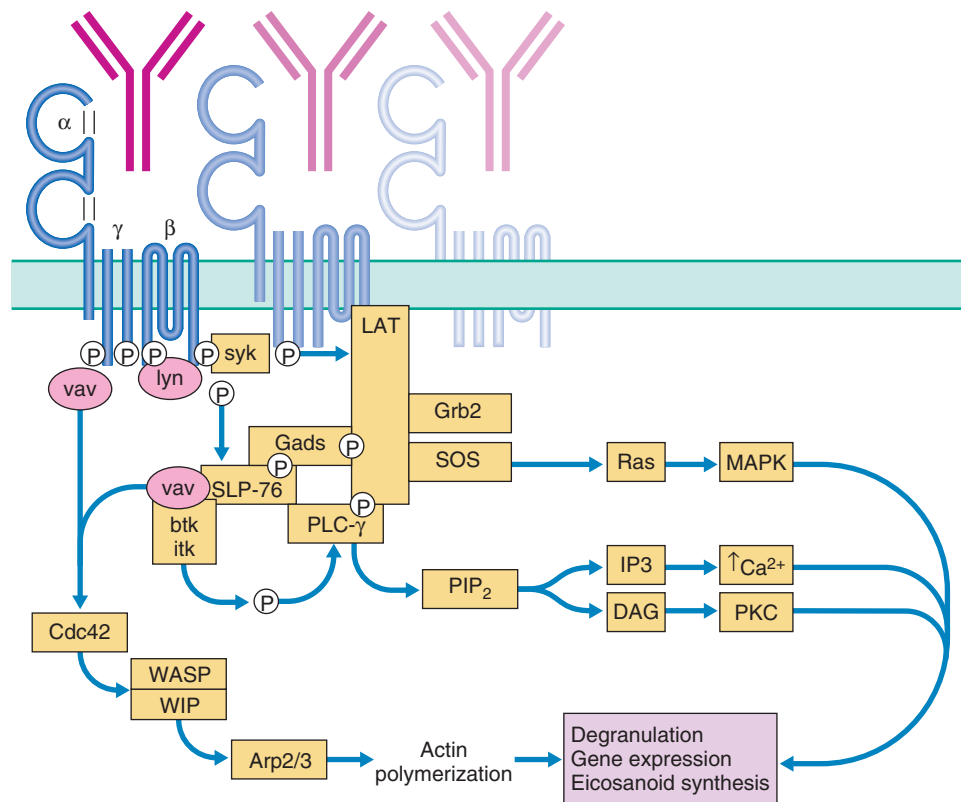

**Figure 4-6** FcεRI structure and signal transduction. FcεRI is a tetramer containing an IgE-binding α-chain (with two extracellular immunoglobulin-type domains), a disulfide-linked, signal-transducing dimer of γ-chains, each of which contains an intracellular immunoreceptor tyrosine-based activation motif (ITAM) and a tetramembrane spanner β-chain that also contains a cytosolic ITAM and serves to augment FcεRI surface expression and signal transduction intensity. Trimeric forms of the receptor, lacking the β-chain, can be expressed on some cell types.

Aggregation of the receptor by the interaction of its ligand, IgE, with polymeric antigens induces signal transduction. The β-chain associated protein tyrosine kinase, lyn, in aggregated receptor complexes phosphorylates (P) the β- and γ-chain ITAMs, generating docking sites for the SH2-domain containing kinase, syk. Activated syk phosphorylates the membrane-associated scaffolding protein LAT as well as the adapter, SLP-76 (which is also bound to LAT via the Grb-2 homolog, Gads). These proteins have no inherent enzymatic activity but serve to assemble a membrane-associated supramolecular complex of proteins that brings together a number of signaling molecules. LAT and SLP-76 both recruit PLC-γ, whose activity is enhanced by the SLP-76 associated kinases btk and itk. PLC-γ activation results in the conversion of PIP<sub>2</sub> (phosphatidylinositol 4,5-bisphosphate) into inositol trisphosphate (IP<sub>3</sub>) and diacyl glycerol (DAG) with resultant increases in intracellular Ca<sup>2+</sup> and activation of protein kinase C (PKC).

Alongside this protein tyrosine kinase pathway, FcεRI aggregation triggers a vav/cytoskeletal signaling cascade. The guanine nucleotide exchange factor, vav, which is directly associated with FcεRI-γ as well as with SLP-76, activates the GTPase Cdc42 which, in turn, induces a conformational change in a complex of proteins, WASP and WIP, associated with the cytoskeleton. This exposes binding sites for Arp2/3, a complex of proteins that mediates actin polymerization. Vav activation also drives the stress-activated protein kinase (SAPK) pathway. Vav and Sos, another guanine nucleotide exchange factor, also result in the activation of the Ras/MAPK pathway. The combined effects of elevated Ca<sup>2+</sup>, PKC activation, actin polymerization and SAPK activation drive mast cell degranulation, eicosanoid formation and induction of gene expression.

#### BOX 4-2 KEY CONCEPTS

##### Principles of Disease Mechanism

##### EFFECTOR FUNCTIONS OF IgE

- |   |  |
|---|--|
| • Mast cell activation/<br>FcεRI          | FcεRI signaling – antigen dependent<br>Immediate hypersensitivity reactions<br>Late-phase reactions<br>FcεRI signaling – antigen independent |
| • IgE regulation of IgE receptors         | FcεRI<br>CD23  |
| • IgE regulation of mast cell homeostasis | Enhanced mast cell survival  |
| • CD23 functions                          | IgE antigen capture<br>Regulation of IgE synthesis by CD23 and sCD23   |

an encounter with polyvalent allergen triggers a cascade of signaling events<sup>82,83</sup> (see Figure 4-6). Receptor aggregation induces transphosphorylation of intracellular ITAMs on FcεRI-β and FcεRI-γ by receptor-associated lyn tyrosine kinase, providing docking sites to recruit the SH2-containing syk protein tyrosine kinase. Syk levels are decreased during chronic IgE-mediated stimulation of FcεRI, suggesting a possible mechanism whereby drug desensitization might attenuate mast cell activation at this early step in the signaling cascade.<sup>84</sup> Receptor-associated syk phosphorylates a series of scaffolding and adapter molecules leading to the assembly of a supramolecular plasma membrane-localized signaling complex, focused around the scaffolding molecules LAT1/2, SLP-76 and Grb2. This complex recruits and activates PLCγ with resultant changes in cytosolic calcium, degranulation, activation of gene transcription and induction of PLA<sub>2</sub> activity with eicosanoid formation. Mast cells from animals with mutations in several key components of this

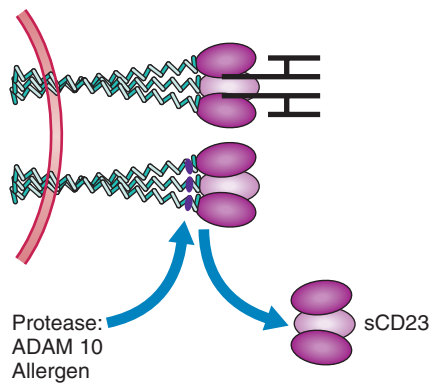

**Figure 4-7** CD23 structure. CD23 is a type II transmembrane protein (with intracellular N-terminus) that contains  $\alpha$ -helical coiled stalks and oligomerizes at the cell surface. Occupancy of the receptor by IgE stabilizes the receptor. In the absence of the IgE ligand, protease-sensitive sites appear (ovals) and endogenous proteases (ADAM10) as well as proteases present in allergens such as Der p 1 cleave CD23, shedding soluble sCD23 into the milieu.

signaling complex, including LAT and SLP-76, have markedly inhibited Fc $\epsilon$ RI-mediated mast cell activation following receptor cross-linking.<sup>85,86</sup> Cytoskeletal reorganization provides a critical parallel signaling pathway driven by Fc $\epsilon$ RI aggregation in mast cells and basophils. This cytoskeletal signaling is driven by the guanine nucleoside exchange factor 'vav'.<sup>87</sup> Vav is encoded a proto-oncogene, important in hematopoiesis, playing a role in T cell and B cell development and activation. Vav associates both with the SLP-76/LAT complex and directly with Fc $\epsilon$ RI.<sup>88</sup> Vav activates Cdc42, a GTPase, which binds to Wiskott-Aldrich syndrome protein (WASP) and induces a conformational change in the cytoskeletal WASP/WASP-interacting protein (WIP) protein complex, allowing interaction with the actin-polymerizing Arp2/3 complex.<sup>89</sup> Vav (as well as Sos, another GTP exchanger) also activates the Ras pathway with resultant transcriptional activation. It has recently been shown that the affinity of antigen:IgE interaction can affect which signaling pathways are preferentially activated, with low-affinity binding favoring Syk phosphorylation of LAT1 and cytokine production and high-affinity binding leading to LAT2 phosphorylation and chemokine production.<sup>90</sup> The activating signaling pathways initiated in mast cells by Fc $\epsilon$ RI cross-linking can be countered by IgG antibodies interacting with the inhibitory receptor, Fc $\gamma$ RIIb. This mechanism may account in part for the ability of patients undergoing allergen immunotherapy, who generate strong IgG responses, to tolerate allergen challenge despite persistently elevated specific IgE.<sup>91,92</sup>

In the classic immediate hypersensitivity reaction, cross-linking of IgE induces the complex signaling cascade described above, resulting in the release of preformed mediators including histamine, proteoglycans and proteases; transcription of cytokines (IL-4, TNF, IL-6); and de novo synthesis of prostaglandins (PGD<sub>2</sub>) and leukotrienes (LTD<sub>4</sub>). In the airways of asthmatic patients, these mediators rapidly elicit bronchial mucosal edema, mucus production and smooth muscle constriction and, eventually, recruit an inflammatory infiltrate. In asthmatic patients subjected to allergen inhalation, these cellular and molecular events result in an acute obstruction of airflow with

a drop in FEV<sub>1</sub>, an effect that can be blocked by inhibition of IgE with a monoclonal anti-IgE antibody.<sup>93–95</sup>

In many subjects exposed to allergens by inhalation, ingestion, cutaneous exposure or injection, immediate responses are followed 8 to 24 hours later by a second, delayed-phase reaction, designated the late-phase response (LPR). LPR can manifest as delayed or repeated onset of airflow obstruction, gastrointestinal symptoms, skin inflammation or anaphylaxis hours after initial allergen exposure and after the acute response has completely subsided. In animal models, IgE antibodies can transfer both acute and LPR sensitivity to allergen challenge.<sup>96</sup> Interference with mast cell activation or inhibition of mast cell mediators blocks the onset of both acute-phase and late-phase responses.<sup>97</sup> It has been proposed that chronic obstructive symptoms in asthma patients subjected to recurrent environmental allergen exposure result from persistent late-phase responses.<sup>98,99</sup>

### Antigen-Independent IgE Signaling via Fc $\epsilon$ RI and IgE Effects on Mast Cell Homeostasis

Although IgE-mediated signaling via Fc $\epsilon$ RI has long been believed to be dependent on antigen-mediated receptor aggregation, some recent evidence suggests that the binding of IgE per se, in the absence of antigen, provides a signal to mast cells and basophils. Experiments using cultured bone marrow mast cells have revealed that monomeric IgE has an Fc $\epsilon$ RI-mediated survival-enhancing effect, protecting these cells from apoptosis following the withdrawal of growth factor.<sup>100,101</sup> A number of other mast cell functions have been reported to be induced by IgE alone, in the absence of antigen, including cytokine production, histamine release, leukotriene synthesis and calcium flux.<sup>102–105</sup>

The observation that IgE antibodies promote the viability of cultured mast cells suggests that IgE might similarly regulate mast cell survival in vivo. Indeed, there is evidence that mast cell induction in parasitized mice or animals exposed to allergens depends upon the presence of IgE antibodies.<sup>106,107</sup> Thus, in addition to their role in allergen-triggered mast cell activation, IgE antibodies are key regulators of mast cell homeostasis.

### Regulation of IgE Receptors by IgE

The expression of both Fc $\epsilon$ RI and CD23 is positively regulated by their mutual ligand, IgE. Fc $\epsilon$ RI expression is markedly diminished on peritoneal mast cells from IgE-deficient mice and this defect can be reversed in vivo by injection of IgE antibodies.<sup>108–110</sup> Low Fc $\epsilon$ RI expression in IgE<sup>-/-</sup> mice is associated with diminished mast cell activation following IgE sensitization and allergen exposure. Treatment of allergic subjects with anti-IgE has been shown to induce a decrease in IgE receptor expression on mast cells, basophils and dendritic cells.<sup>88,111,112</sup>

CD23 expression on cultured B cells is enhanced in the presence of IgE, which, by occupancy of its receptor, prevents proteolytic degradation of CD23 and shedding into the medium.<sup>73,113</sup> This shedding is mediated by the endogenous protease, ADAM10, but can also be triggered by allergens with protease activity, including Der p 1.<sup>114,115</sup> This regulatory interaction between IgE and CD23 is operative in vivo as well: B cells from IgE<sup>-/-</sup> animals have markedly diminished CD23 levels and intravenous injection of IgE induces normal CD23 expression.<sup>116</sup> Restoration of CD23 expression can be induced using



monomeric IgE and is antigen independent. Exposure to IgE does not alter transcription of mRNA encoding CD23 or the FcεRI subunits but rather modulates receptor turnover and proteolytic shedding.<sup>117</sup> The positive feedback interaction between IgE and its receptors may have implications in terms of augmenting allergic responses in atopic individuals with high IgE levels.

### CD23 Function: Antigen Capture

Several investigators have now shown that the binding of allergen by specific IgE facilitates allergen uptake by CD23-bearing cells for processing and presentation to T cells.<sup>118–120</sup> Mice immunized intravenously with antigen produce stronger IgG responses when antigen-specific IgE is provided at the time of immunization.<sup>121,122</sup> As expected, CD23<sup>-/-</sup> mice cannot display augmentation of immune responses by IgE but acquire responsiveness to IgE following reconstitution with cells from CD23<sup>+</sup> donors.<sup>123,124</sup> These findings suggest a scenario in which preformed allergen-specific IgE present in the bronchial and gut mucosa of patients with recurrent allergen exposure would enhance immune responses upon repeated allergen inhalation or ingestion.

### CD23 Function: IgE Regulation

In addition to its role in allergen uptake, CD23 appears to have regulatory influences on IgE synthesis and allergic inflammation. Although the data in this area have seemed to be conflicting at times, the emerging consensus from human and animal studies is that ligation of membrane-bound CD23 on B cells suppresses IgE production. Ligation of CD23 on human B cells by activating antibodies inhibits IgE synthesis<sup>125</sup> and transgenic mice overexpressing CD23 have suppressed IgE responses.<sup>126,127</sup> Conversely, mice rendered CD23-deficient by targeted gene disruption have increased and sustained specific IgE titers following immunization, also consistent with a suppressive effect of membrane-bound CD23.<sup>128</sup> This enhanced tendency toward IgE synthesis in CD23<sup>-/-</sup> mice is also observed following allergen inhalation and is accompanied by increased eosinophilic inflammation of the airways.<sup>129–132</sup>

In contrast, there have been reports that soluble CD23 (sCD23) fragments, which are generated by proteolytic cleavage, may enhance IgE production, either by direct interaction with B cells (via CD21) or by binding to IgE, thereby blocking its interaction with membrane-bound CD23.<sup>133</sup> The IgE-enhancing effects of crude sCD23 have not yet been reproduced with recombinant sCD23<sup>134</sup> and it is unclear whether this discrepancy arises from IgE-inducing activity attributable to other components of sCD23-containing culture supernatants or whether the lack of activity of recombinant sCD23 is the consequence of a nonphysiologic structure. Recent data implicate a role for allergens, some of which are proteases, as effectors of CD23 cleavage and for IgE itself as a stabilizer of membrane CD23 and inhibitor of proteolytic shedding.<sup>135</sup> Two possible consequences of such allergen-mediated cleavage would be decreased suppressive signaling to the B cell via CD23, along with increased production of activating sCD23 fragments, both promoting IgE production. Inhibition of proteolytic activity of Der p 1 blocks its ability to induce IgE responses *in vivo* both in normal and humanized scid mice.<sup>136,137</sup> Similar effects are observed in culture systems. Metalloproteinase inhibitors block sCD23 shedding in cultures of tonsillar B cells or peripheral

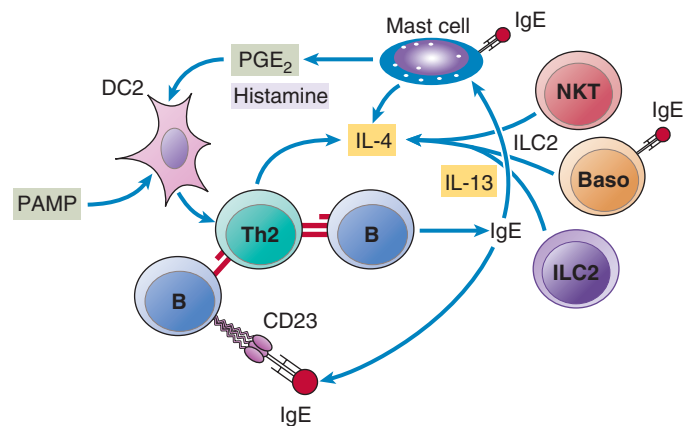

**Figure 4-8** The IgE network: cellular and cytokine control of IgE production in allergic tissues and amplification of allergic responses by preformed IgE. A confluence of cellular and molecular stimuli supports IgE synthesis in the tissues of asthmatic patients. Tissue DCs are driven toward a Th2-promoting DC2 phenotype by a variety of environmental influences, including exposure to microbial 'pathogen-associated molecular patterns' (PAMPs) and histamine and PGE<sub>2</sub> (both of which can be provided by mast cells). Activated DC2s translocate to mucosal- or skin-associated lymphoid tissues where they attain competence as antigen-presenting cells (APCs) and drive the generation of Th2 cells. B cells also serve as APCs, a function that is augmented when preformed IgE (generated during previous allergen encounter) is present and can facilitate B cell antigen uptake via CD23.

IL-4 and IL-13 are derived from numerous cellular sources. In the setting of recurrent allergen challenge, preexisting, allergen-specific Th2 T cells are likely to provide a major source of IL-4. Additional producers of IL-4 include NKT cells and mast cells. Mast cell IL-4 synthesis can be triggered via FcεRI in the presence of preformed IgE. IL-4 and IL-13 along with cognate T-B interactions involving antigen presentation and CD40 signaling then support IgE isotype switching in B cells.

blood mononuclear cells, and this is accompanied by decreased IgE production following stimulation with IL-4.<sup>138</sup>

## Conclusions

To summarize, IgE antibodies are typically elevated in individuals affected by the atopic conditions of asthma, allergic rhinitis and atopic dermatitis. The production of IgE follows a series of complex genomic rearrangements in B cells, called deletional class switch recombination, a process that is tightly regulated by the cytokines IL-4 and IL-13 along with T-B cell interaction and CD40/CD154 signaling. IgE antibodies exert their biologic effects via receptors FcεRI and CD23. It is now clear that, in addition to mediating the classic immediate hypersensitivity reactions by inducing acute mediator release by mast cells, IgE antibodies have a number of immunomodulatory functions (Figure 4-8). These include up-regulation of IgE receptors, promotion of mast cell survival, enhancement of allergen uptake by B cells for antigen presentation, and induction of Th2 cytokine expression by mast cells and may all collaborate to amplify and perpetuate allergic responses in susceptible individuals. Thus, blockade of IgE effects, using novel anti-IgE therapies, may ultimately prove to have a broad benefit.

The complete reference list can be found on the companion Expert Consult website at <http://www.expertconsult.inkling.com>.

## KEY REFERENCES

64. Burton OT, Noval-Rivas M, Zhou JS, Logsdon SL, Darling AR, Koleoglu KJ, et al. Immunoglobulin E signal inhibition during allergen ingestion leads to reversal of established food allergy and induction of regulatory T cells. *Immunity* 2014;41:141–51.
67. Akdis M, Akdis CA. IgE class switching and cellular memory. *Nat Immunol* 2012;13:312–14.
90. Suzuki R, Leach S, Liu W, Ralston E, Scheffel J, Zhang W, et al. Molecular editing of cellular responses by the high-affinity receptor for IgE. *Science* 2014;343:1021–5.
92. Daeron M, Latour S, Malbec O, Espinosa E, Pina P, Pasmans S, et al. The same tyrosine-based inhibition motif, in the intracytoplasmic domain of Fc gamma RIIB, regulates negatively BCR-, TCR-, and FcR-dependent cell activation. *Immunity* 1995;3:635–46.
99. McFadden ER, Gilbert IA. Asthma. *N Engl J Med* 1992;327:1928–37.
100. Asai K, Kitaura J, Kawakami Y, Yamagata N, Tsai M, Carbone DP, et al. Regulation of mast cell survival by IgE. *Immunity* 2001;14:791–800.
108. Lantz CS, Yamaguchi M, Oettgen HC, Katona IM, Miyajima I, Kinet JP, et al. IgE regulates mouse basophil Fc epsilon RI expression in vivo. *J Immunol* 1997;158:2517–21.
110. Yamaguchi M, Sayama K, Yano K, Lantz CS, Noben-Trauth N, Ra C, et al. IgE enhances Fc epsilon receptor I expression and IgE-dependent release of histamine and lipid mediators from human umbilical cord blood-derived mast cells: synergistic effect of IL-4 and IgE on human mast cell Fc epsilon receptor I expression and mediator release. *J Immunol* 1999;162:5455–65.
111. Beck LA, Marcotte GV, MacGlashan D, Togias A, Saini S. Omalizumab-induced reductions in mast cell Fc epsilon RI expression and function. *J Allergy Clin Immunol* 2004;114:527–30.
112. Saini SS, MacGlashan DW Jr, Sterbinsky SA, Togias A, Adelman DC, Lichtenstein LM, et al. Down-regulation of human basophil IgE and Fc epsilon RI alpha surface densities and mediator release by anti-IgE-infusions is reversible in vitro and in vivo. *J Immunol* 1999;162:5624–30.

## REFERENCES

- Liu FT. Gene expression and structure of immunoglobulin epsilon chains. *Crit Rev Immunol* 1986;6:47-69.
- Oettgen HC. Regulation of the IgE isotype switch: new insights on cytokine signals and the functions of epsilon germline transcripts. *Curr Opin Immunol* 2000;12:618-23.
- Chaudhuri J, Alt FW. Class-switch recombination: interplay of transcription, DNA deamination and DNA repair. *Nat Rev Immunol* 2004;4:541-52.
- Del Prete G, Maggi E, Parronchi P, Chretien I, Tiri A, Macchia D, et al. IL-4 is an essential factor for the IgE synthesis induced in vitro by human T cells clones and their supernatants. *J Immunol* 1988;140:4193-8.
- Vercelli D, Jabara H, Arai K-I, Geha R. Induction of human IgE synthesis requires interleukin 4 and T/B interactions involving the T cell receptor/CD3 complex and MHC class II antigens. *J Exp Med* 1989;169:1295-307.
- Gauchat J-F, Leberman D, Coffman R, Gascan H, de Vries J. Structure and expression of germ-line e transcripts in human B cells induced by interleukin 4 to switch to IgE production. *J Exp Med* 1990;172:463-73.
- Kim J, Reeves R, Rothman P, Boothby M. The non-histone chromosomal protein HMG-I(Y) contributes to repression of the immunoglobulin heavy chain germ-line epsilon RNA promoter. *Eur J Immunol* 1995;25:798-808.
- Wang DZ, Cherrington A, Famakin-Mosuro B, Boothby M. Independent pathways for de-repression of the mouse Ig heavy chain germ-line epsilon promoter: an IL-4 NAF/NF-IL-4 site as a context-dependent negative element. *Int Immunol* 1996;8:977-89.
- Wang DZ, Ray P, Boothby M. Interleukin 4-inducible phosphorylation of HMG-I(Y) is inhibited by rapamycin. *J Biol Chem* 1995;270:22924-32.
- Monticelli S, De Monte L, Vercelli D. Molecular regulation of IgE switching: let's walk hand in hand. *Allergy* 1998;53:6-8.
- Thienes CP, De Monte L, Monticelli S, Busslinger M, Gould HJ, Vercelli D. The transcription factor B cell-specific activator protein (BSAP) enhances both IL-4- and CD40-mediated activation of the human epsilon germline promoter. *J Immunol* 1997;158:5874-82.
- Harris MB, Chang CC, Berton MT, Danial NN, Zhang J, Kuehner D, et al. Transcriptional repression of Stat6-dependent interleukin-4-induced genes by BCL-6: specific regulation of epsilon transcription and immunoglobulin E switching. *Mol Cell Biol* 1999;19:7264-75.
- Kitayama D, Sakamoto A, Arima M, Hatano M, Miyazaki M, Tokuhisa T. A role for Bcl6 in sequential class switch recombination to IgE in B cells stimulated with IL-4 and IL-21. *Mol Immunol* 2008;45:1337-45.
- Harada M, Magara-Koyanagi K, Watarai H, Nagata Y, Ishii Y, Kojo S, et al. IL-21-induced Bepsilon cell apoptosis mediated by natural killer T cells suppresses IgE responses. *J Exp Med* 2006;203:2929-37.
- Suto A, Nakajima H, Hirose K, Suzuki K, Kagami S, Seto Y, et al. Interleukin 21 prevents antigen-induced IgE production by inhibiting germ line C(epsilon) transcription of IL-4-stimulated B cells. *Blood* 2002;100:4565-73.
- Defrance T, Carayon P, Billian G, Guillemot J-C, Minty A, Caput D, et al. Interleukin 13 is a B cell stimulating factor. *J Exp Med* 1994;179:135-43.
- Punnonen J, Aversa G, Cocks B, McKenzie A, Menon S, Zurawski G, et al. Interleukin 13 induces interleukin 4-independent IgG4 and IgE synthesis and CD23 expression by human B cells. *Proc Natl Acad Sci U S A* 1993;90:3730-4.
- Palmer-Crocker P, Hughes C, Pober J. IL-4 and IL-13 activate the JAK2 tyrosine kinase and STAT6 in cultured human vascular endothelial cells through a common pathway that does not involve the gc chain. *J Clin Invest* 1996;98:604-9.
- Rolling C, Treton D, Beckmann P, Galanaud P, Richard Y. JAK3 associates with the human interleukin 4 receptor and is tyrosine phosphorylated following receptor triggering. *Oncogene* 1995;10:1757-61.
- Welham M, Learmonth L, Bone H, Schrader J. Interleukin-13 signal transduction in lymphohemopoietic cells. *J Biol Chem* 1995;270:12286-96.
- Withuhn B, Silvennoinen O, Miura O, Lai K, Cwik C, Liu E, et al. Involvement of the Jak-3 Janus kinase in signalling by interleukins 2 and 4 in lymphoid and myeloid cells. *Nature* 1994;370:153-7.
- Schindler C, Kashleva H, Pernis A, Pine R, Rothman P. STF-IL-4: a novel IL-4-induced signal transducing factor. *EMBO J* 1994;13:1350-6.
- Ivashkiv L. Cytokines and STATs: how can signals achieve specificity? *Immunity* 1995;3:1-4.
- Grewal I, Flavell R. A central role of CD40 ligand in the regulation of CD4+ T-cell responses. *Immunol Today* 1996;17:410-14.
- Cheng G, Cleary AM, Ye Z, Hong DI, Lederman S, Baltimore D. Involvement of CRAF1, a relative of TRAF, in CD40 signaling. *Science* 1995;267:1494-8.
- Ishida T, Mizushima S, Azuma S, Kobayashi N, Tojo T, Suzuki K, et al. Identification of TRAF6, a novel tumor necrosis factor receptor-associated protein that mediates signaling from an amino-terminal domain of the CD40 cytoplasmic region. *J Biol Chem* 1996;271:28745-8.
- Iciek LA, Delphin SA, Stavnezer J. CD40 cross-linking induces Ig epsilon germline transcripts in B cells via activation of NF-kappaB: synergy with IL-4 induction. *J Immunol* 1997;158:4769-79.
- Messner B, Stutz A, Albrecht B, Peiritsch S, Woisetschlager M. Cooperation of binding sites for STAT6 and NF kappa B/rel in the IL-4-induced up-regulation of the human IgE germline promoter. *J Immunol* 1997;159:3330-7.
- Faris M, Gaskin F, Geha R, Fu S. Tyrosine phosphorylation defines a unique transduction pathway in human B cells mediated via CD40. *Trans Assoc Am Physicians* 1993;106:187-95.
- Ren C, Morio T, Fu S, Geha R. Signal transduction via CD40 involves activation of lyn kinase and phosphatidylinositol-3-kinase, and phosphorylation of phospholipase C gamma 2. *J Exp Med* 1994;179:673-80.
- Allen RC, Armitage RJ, Conley ME, Rosenblatt H, Jenkins NA, Copeland NG, et al. CD40 ligand gene defects responsible for X-linked hyper-IgM syndrome [see comments]. *Science* 1993;259:990-3.
- Aruffo A, Farrington M, Hollenbaugh D, Li X, Milatovich A, Nonoyama S, et al. The CD40 ligand, gp39, is defective in activated T cells from patients with X-linked hyper-IgM syndrome. *Cell* 1993;72:291-300.
- DiSanto JP, Bonnefoy JY, Gauchat JF, Fischer A, de Saint Basile G. CD40 ligand mutations in x-linked immunodeficiency with hyper-IgM [see comments]. *Nature* 1993;361:541-3.
- Fuleihan R, Ramesh N, Loh R, Jabara H, Rosen RS, Chatila T, et al. Defective expression of the CD40 ligand in X chromosome-linked immunoglobulin deficiency with normal or elevated IgM. *Proc Natl Acad Sci U S A* 1993;90:2170-3.
- Korhauer U, Graf D, Mages HW, Briere F, Padayachee M, Malcolm S, et al. Defective expression of T-cell CD40 ligand causes X-linked immunodeficiency with hyper-IgM [see comments]. *Nature* 1993;361:539-41.
- Castigli E, Geha RS. TACI, isotype switching, CVID and IgAD. *Immunol Res* 2007;38:102-11.
- Castigli E, Wilson SA, Scott S, Dedeoglu F, Xu S, Lam KP, et al. TACI and BAFF-R mediate isotype switching in B cells. *J Exp Med* 2005;201:35-9.
- Castigli E, Wilson S, Garibyan L, Rachid R, Bonilla F, Schneider L, et al. Reexamining the role of TACI coding variants in common variable immunodeficiency and selective IgA deficiency. *Nat Genet* 2007;39:430-1.
- Castigli E, Wilson SA, Garibyan L, Rachid R, Bonilla F, Schneider L, et al. TACI is mutant in common variable immunodeficiency and IgA deficiency. *Nat Genet* 2005;37:829-34.
- Kato A, Truong-Tran AQ, Scott AL, Matsumoto K, Schleimer RP. Airway epithelial cells produce B cell-activating factor of TNF family by an IFN-beta-dependent mechanism. *J Immunol* 2006;177:7164-72.
- Kato A, Xiao H, Chustz RT, Liu MC, Schleimer RP. Local release of B cell-activating factor of the TNF family after segmental allergen challenge of allergic subjects. *J Allergy Clin Immunol* 2009;123:369-75.
- Cameron L, Gounni AS, Frenkiel S, Lavigne F, Vercelli D, Hamid Q. S epsilon S mu and S epsilon S gamma switch circles in human nasal mucosa following ex vivo allergen challenge: evidence for direct as well as sequential class switch recombination. *J Immunol* 2003;171:3816-22.
- Muramatsu M, Kinoshita K, Fagarasan S, Yamada S, Shinkai Y, Honjo T. Class switch recombination and hypermutation require activation-induced cytidine deaminase (AID), a potential RNA editing enzyme [see comments]. *Cell* 2000;102:553-63.
- Muramatsu M, Sankaranand VS, Anant S, Sugai M, Kinoshita K, Davidson NO, et al. Specific expression of activation-induced cytidine deaminase (AID), a novel member of the RNA-editing deaminase family in germinal center B cells. *J Biol Chem* 1999;274:18470-6.
- Revy P, Muto T, Levy Y, Geissmann F, Plebani A, Sanal O, et al. Activation-induced cytidine deaminase (AID) deficiency causes the autosomal recessive form of the hyper-IgM syndrome (HIGM2) [see comments]. *Cell* 2000;102:565-75.
- Longerich S, Basu U, Alt F, Storb U. AID in somatic hypermutation and class switch

- recombination. *Curr Opin Immunol* 2006;18:164–74.
47. Soulas-Sprauel P, Rivera-Munoz P, Malivert L, Le Guyader G, Abramowski V, Revy P, et al. V(D)J and immunoglobulin class switch recombinations: a paradigm to study the regulation of DNA end-joining. *Oncogene* 2007;26:7780–91.
  48. Manis JP, Dudley D, Kaylor L, Alt FW. IgH class switch recombination to IgG1 in DNA-PKcs-deficient B cells. *Immunity* 2002;16:607–17.
  49. Manis JP, Gu Y, Lansford R, Sonoda E, Ferrini R, Davidson L, et al. Ku70 is required for late B cell development and immunoglobulin heavy chain class switching. *J Exp Med* 1998;187:2081–9.
  50. Annunziato F, Galli G, Cosmi L, Romagnani P, Manetti R, Maggi E, et al. Molecules associated with human Th1 or Th2 cells. *Eur Cytokine Netw* 1998;9(Suppl. 3):12–16.
  51. Coyle AJ, Lloyd C, Tian J, Nguyen T, Eriksson C, Wang L, et al. Crucial role of the interleukin 1 receptor family member T1/ST2 in T helper cell type 2-mediated lung mucosal immune responses. *J Exp Med* 1999;190:895–902.
  52. Sallusto F, Mackay CR, Lanzavecchia A. The role of chemokine receptors in primary, effector, and memory immune responses. *Annu Rev Immunol* 2000;18:593–620.
  53. Sallusto F, Schaeferli P, Loetscher P, Scharniel C, Lenig D, Mackay CR, et al. Rapid and coordinated switch in chemokine receptor expression during dendritic cell maturation. *Eur J Immunol* 1998;28:2760–9.
  54. Murphy KM, Ouyang W, Szabo SJ, Jacobson NG, Guler ML, Gorham JD, et al. T helper differentiation proceeds through Stat1-dependent, Stat4-dependent and Stat4-independent phases. *Curr Top Microbiol Immunol* 1999;238:13–26.
  55. Kalinski P, Hilkens CM, Wierenga EA, Kapsenberg ML. T-cell priming by type-1 and type-2 polarized dendritic cells: the concept of a third signal. *Immunol Today* 1999;20:561–7.
  56. Pasare C, Medzhitov R. Toll pathway-dependent blockade of CD4+CD25+ T cell-mediated suppression by dendritic cells. *Science* 2003;299:1033–6.
  57. Kalinski P, Schuitemaker JH, Hilkens CM, Kapsenberg ML. Prostaglandin E2 induces the final maturation of IL-12-deficient CD1a+CD83+ dendritic cells: the levels of IL-12 are determined during the final dendritic cell maturation and are resistant to further modulation. *J Immunol* 1998;161:2804–9.
  58. Mazzoni A, Young HA, Spitzer JH, Visintin A, Segal DM. Histamine regulates cytokine production in maturing dendritic cells, resulting in altered T cell polarization. *J Clin Invest* 2001;108:1865–73.
  59. Vieira PL, de Jong EC, Wierenga EA, Kapsenberg ML, Kalinski P. Development of Th1-inducing capacity in myeloid dendritic cells requires environmental instruction. *J Immunol* 2000;164:4507–12.
  60. Kalinski P, Hilkens CM, Snijders A, Snijdewint FG, Kapsenberg ML. IL-12-deficient dendritic cells, generated in the presence of prostaglandin E2, promote type 2 cytokine production in maturing human naive T helper cells. *J Immunol* 1997;159:28–35.
  61. Stumbles PA, Thomas JA, Pimm CL, Lee PT, Venaille TJ, Proksch S, et al. Resting respiratory tract dendritic cells preferentially stimulate T helper cell type 2 (Th2) responses and require obligatory cytokine signals for induction of Th1 immunity. *J Exp Med* 1998;188:2019–31.
  62. Galli SJ. Complexity and redundancy in the pathogenesis of asthma: reassessing the roles of mast cells and T cells. *J Exp Med* 1997;186:343–7.
  63. Toru H, Pawankar R, Ra C, Yata J, Nakahata T. Human mast cells produce IL-13 by high-affinity IgE receptor cross-linking: enhanced IL-13 production by IL-4-primed human mast cells. *J Allergy Clin Immunol* 1998;102:491–502.
  64. Burton OT, Noval-Rivas M, Zhou JS, Logsdon SL, Darling AR, Koleoglu KJ, et al. Immunoglobulin E signal inhibition during allergen ingestion leads to reversal of established food allergy and induction of regulatory T cells. *Immunity* 2014;41:141–51.
  65. Yoshimoto T, Bendelac A, Hu-Li J, Paul WE. Defective IgE production by SJL mice is linked to the absence of CD4+, NK1.1+ T cells that promptly produce interleukin 4. *Proc Natl Acad Sci U S A* 1995;92:11931–4.
  66. Spits H, Artis D, Colonna M, Diefenbach A, Di Santis JP, Eberl G, et al. Innate lymphoid cells—a proposal for uniform nomenclature. *Nat Rev Immunol* 2013;13:145–9.
  67. Akdis M, Akdis CA. IgE class switching and cellular memory. *Nat Immunol* 2012;13:312–14.
  68. Wu LC, Zarrin AA. The production and regulation of IgE by the immune system. *Nat Rev Immunol* 2014;14:247–59.
  69. Kinet JP. The high-affinity IgE receptor (Fc epsilon RI): from physiology to pathology. *Annu Rev Immunol* 1999;17:931–72.
  70. Donnadieu E, Jouvin MH, Kinet JP. A second amplifier function for the allergy-associated Fc(epsilon)RI-beta subunit. *Immunity* 2000;12:515–23.
  71. Dombrowicz D, Lin S, Flamand V, Brini AT, Koller BH, Kinet JP. Allergy-associated FcRbeta is a molecular amplifier of IgE- and IgG-mediated in vivo responses. *Immunity* 1998;8:517–29.
  72. Lin S, Cicala C, Scharenberg AM, Kinet JP. The Fc(epsilon)RIbeta subunit functions as an amplifier of Fc(epsilon)RIgamma-mediated cell activation signals. *Cell* 1996;85:985–95.
  73. Lee WT, Conrad DH. Murine B cell hybridomas bearing ligand-inducible Fc receptors for IgE. *J Immunol* 1986;136:4573–80.
  74. Vander-Mallie R, Ishizaka T, Ishizaka K. Lymphocyte bearing Fc Receptors for IgE. VIII. Affinity of Mouse IgE for FcR on Mouse B Lymphocytes. *J Immunol* 1982;128:2306–12.
  75. Delespesse G, Sarfati M, Hofstetter H, Suter U, Nakajima T, Peleman R, et al. Structure, function and clinical relevance of the low affinity receptor for IgE. *Immunol Invest* 1988;17:363–87.
  76. Gould HJ, Sutton BJ. IgE in allergy and asthma today. *Nat Rev Immunol* 2008;8:205–17.
  77. Bettler B, Hofstetter H, Rao M, Yokoyama WM, Kilcherr F, Conrad DH. Molecular structure and expression of the murine lymphocyte low-affinity receptor for IgE (Fc epsilon RII). *Proc Natl Acad Sci U S A* 1989;86:7566–70.
  78. Kikutani H, Inui S, Sato R, Barsumian EL, Owaki H, Yamasaki K, et al. Molecular structure of human lymphocyte receptor for immunoglobulin E. *Cell* 1986;47:657–65.
  79. Dierks SE, Bartlett WC, Edmeades RL, Gould HJ, Rao M, Conrad DH. The oligomeric nature of the murine Fc epsilon RII/CD23. Implications for function. *J Immunol* 1993;150:2372–82.
  80. Aubry J-P, Pochon S, Graber P, Jansen K, Bonnefoy J-Y. CD21 is a ligand for CD23 and regulates IgE production. *Nature* 1992;358:505–7.
  81. Aubry JP, Pochon S, Gauchat JF, Nueda MA, Holers VM, Graber P, et al. CD23 interacts with a new functional extracytoplasmic domain involving N-linked oligosaccharides on CD21. *J Immunol* 1994;152:5806–13.
  82. Gilfillan AM, Rivera J. The tyrosine kinase network regulating mast cell activation. *Immunol Rev* 2009;228:149–69.
  83. Rivera J, Gilfillan AM. Molecular regulation of mast cell activation. *J Allergy Clin Immunol* 2006;117:1214–25, quiz 26.
  84. Macglashan D, Miura K. Loss of syk kinase during IgE-mediated stimulation of human basophils. *J Allergy Clin Immunol* 2004;114:1317–24.
  85. Pivniouk VI, Martin TR, Lu-Kuo JM, Katz HR, Oettgen HC, Geha RS. SLP-76 deficiency impairs signaling via the high-affinity IgE receptor in mast cells. *J Clin Invest* 1999;103:1737–43.
  86. Saitoh S, Arudchandran R, Manetz TS, Zhang W, Sommers CL, Love PE, et al. LAT is essential for Fc(epsilon)RI-mediated mast cell activation. *Immunity* 2000;12:525–35.
  87. Manetz TS, Gonzalez-Espinosa C, Arudchandran R, Xirasagar S, Tybulewicz V, Rivera J. Vav1 regulates phospholipase cgamma activation and calcium responses in mast cells. *Mol Cell Biol* 2001;21:3763–74.
  88. Prussin C, Griffith DT, Boesel KM, Lin H, Foster B, Casale TB. Omalizumab treatment downregulates dendritic cell FcepsilonRI expression. *J Allergy Clin Immunol* 2003;112:1147–54.
  89. Pivniouk VI, Snapper SB, Kettner A, Alenius H, Laouini D, Falet H, et al. Impaired signaling via the high-affinity IgE receptor in Wiskott-Aldrich syndrome protein-deficient mast cells. *Int Immunol* 2003;15:1431–40.
  90. Suzuki R, Leach S, Liu W, Ralston E, Scheffel J, Zhang W, et al. Molecular editing of cellular responses by the high-affinity receptor for IgE. *Science* 2014;343:1021–5.
  91. Burton OT, Logsdon SL, Zhou JS, Medina-Tamayo J, Abdel-Gadir A, Noval-Rivas M, et al. Oral immunotherapy induces IgG antibodies that act through FcγRIIb to suppress IgE-mediated hypersensitivity. *J Allergy Clin Immunol* 2014;134:1310–17.
  92. Dæron M, Latour S, Malbec O, Espinosa E, Pina P, Pasmans S, et al. The same tyrosine-based inhibition motif, in the intracytoplasmic domain of Fc gamma RIIB, regulates negatively BCR-, TCR-, and FcR-dependent cell activation. *Immunity* 1995;3:635–46.
  93. Fahy JV, Fleming HE, Wong HH, Liu JT, Su JQ, Reimann J, et al. The effect of an anti-IgE monoclonal antibody on the early- and late-phase responses to allergen inhalation in asthmatic subjects. *Am J Respir Crit Care Med* 1997;155:1828–34.
  94. Howarth PH, Durham SR, Kay AB, Holgate ST. The relationship between mast cell-mediator release and bronchial reactivity in allergic asthma. *J Allergy Clin Immunol* 1987;80:703–11.
  95. Fahy JV, Fleming HE, Wong HH, Liu JT, Su JQ, Reimann J, et al. The effect of an anti-IgE monoclonal antibody on the early- and



- late-phase responses to allergen inhalation in asthmatic subjects [see comments]. *Am J Respir Crit Care Med* 1997;155:1828–34.
96. Shampain MP, Behrens BL, Larsen GL, Henson PM. An animal model of late pulmonary responses to *Alternaria* challenge. *Am Rev Respir Dis* 1982;126:493–8.
  97. Cockcroft DW, Murdock KY. Comparative effects of inhaled salbutamol, sodium cromoglycate and beclomethasone dipropionate on allergen-induced early asthmatic responses, late asthmatic responses and increased bronchial responsiveness to histamine. *J Allergy Clin Immunol* 1987;79:734–40.
  98. Cartier A, Thomson NC, Frith PA, Roberts R, Hargreave FE. Allergen-induced increase in bronchial responsiveness to histamine: relationship to the late asthmatic response and change in airway caliber. *J Allergy Clin Immunol* 1982;70:170–7.
  99. McFadden ER, Gilbert IA. Asthma. *N Engl J Med* 1992;327:1928–37.
  100. Asai K, Kitaura J, Kawakami Y, Yamagata N, Tsai M, Carbone DP, et al. Regulation of mast cell survival by IgE. *Immunity* 2001;14:791–800.
  101. Kalesnikoff J, Huber M, Lam V, Damen JE, Zhang J, Siraganian RP, et al. Monomeric IgE stimulates signaling pathways in mast cells that lead to cytokine production and cell survival. *Immunity* 2001;14:801–11.
  102. Kawakami T, Kitaura J. Mast cell survival and activation by IgE in the absence of antigen: a consideration of the biologic mechanisms and relevance. *J Immunol* 2005;175:4167–73.
  103. Kitaura J, Song J, Tsai M, Asai K, Maeda-Yamamoto M, Mocsai A, et al. Evidence that IgE molecules mediate a spectrum of effects on mast cell survival and activation via aggregation of the FcεRI. *Proc Natl Acad Sci U S A* 2003;100:12911–16.
  104. Tanaka S, Takasu Y, Mikura S, Satoh N, Ichikawa A. Antigen-independent induction of histamine synthesis by immunoglobulin E in mouse bone marrow-derived mast cells. *J Exp Med* 2002;196:229–35.
  105. Pandey V, Mihara S, Fensome-Green A, Bolsover S, Cockcroft S. Monomeric IgE stimulates NFAT translocation into the nucleus, a rise in cytosol Ca<sup>2+</sup>, degranulation, and membrane ruffling in the cultured rat basophilic leukemia-2H3 mast cell line. *J Immunol* 2004;172:4048–58.
  106. Gurish MF, Bryce PJ, Tao H, Kisselgof AB, Thornton EM, Miller HR, et al. IgE enhances parasite clearance and regulates mast cell responses in mice infected with *Trichinella spiralis*. *J Immunol* 2004;172:1139–45.
  107. Mathias CB, Freyschmidt EJ, Caplan B, Jones T, Poddighe D, Xing W, et al. IgE influences the number and function of mature mast cells, but not progenitor recruitment in allergic pulmonary inflammation. *J Immunol* 2009;182:2416–24.
  108. Lantz CS, Yamaguchi M, Oettgen HC, Katona IM, Miyajima I, Kinet JP, et al. IgE regulates mouse basophil FcεRI expression in vivo. *J Immunol* 1997;158:2517–21.
  109. Yamaguchi M, Lantz CS, Oettgen HC, Katona IM, Fleming T, Miyajima I, et al. IgE enhances mouse mast cell Fc(ε)RI expression in vitro and in vivo: evidence for a novel amplification mechanism in IgE-dependent reactions. *J Exp Med* 1997;185:663–72.
  110. Yamaguchi M, Sayama K, Yano K, Lantz CS, Noben-Trauth N, Ra C, et al. IgE enhances FcεRI expression and IgE-dependent release of histamine and lipid mediators from human umbilical cord blood-derived mast cells: synergistic effect of IL-4 and IgE on human mast cell FcεRI expression and mediator release. *J Immunol* 1999;162:5455–65.
  111. Beck LA, Marcotte GV, MacGlashan D, Togias A, Saini S. Omalizumab-induced reductions in mast cell FcεRI expression and function. *J Allergy Clin Immunol* 2004;114:527–30.
  112. Saini SS, MacGlashan DW Jr, Sterbinsky SA, Togias A, Adelman DC, Lichtenstein LM, et al. Down-regulation of human basophil IgE and FcεRI α surface densities and mediator release by anti-IgE-infusions is reversible in vitro and in vivo. *J Immunol* 1999;162:5624–30.
  113. Lee WT, Rao M, Conrad DH. The murine lymphocyte receptor for IgE. IV. The mechanism of ligand-specific receptor upregulation on B cells. *J Immunol* 1987;139:1191–8.
  114. Lemieux GA, Blumenkron F, Yeung N, Zhou P, Williams J, Grammer AC, et al. The low affinity IgE receptor (CD23) is cleaved by the metalloproteinase ADAM10. *J Biol Chem* 2007;282:14836–44.
  115. Weskamp G, Ford JW, Sturgill J, Martin S, Docherty AJ, Swendeman S, et al. ADAM10 is a principal ‘shedase’ of the low-affinity immunoglobulin E receptor CD23. *Nat Immunol* 2006;7:1293–8.
  116. Kisselgof AB, Oettgen HC. The expression of murine B cell CD23, in vivo, is regulated by its ligand, IgE. *Int Immunol* 1998;10:1377–84.
  117. Borkowski TA, Jouvin MH, Lin SY, Kinet JP. Minimal requirements for IgE-mediated regulation of surface FcεRI. *J Immunol* 2001;167:1290–6.
  118. Kehry MR, Hudak SA. Characterization of B-cell populations bearing FcεRII. *Cell Immunol* 1989;118:504–15.
  119. Pirron U, Schlunck T, Prinz JC, Rieber EP. IgE-dependent antigen focusing by human B lymphocytes is mediated by the low-affinity receptor for IgE. *Eur J Immunol* 1990;20:1547–51.
  120. van der Heijden FL, Joost van Neerven RJ, van Katwijk M, Bos JD, Kapsenberg ML. Serum-IgE-facilitated allergen presentation in atopic disease. *J Immunol* 1993;150:3643–50.
  121. Gustavsson S, Hjulstrom S, Liu T, Heyman B. CD23/IgE-mediated regulation of the specific antibody response in vivo. *J Immunol* 1994;152:4793–800.
  122. Heyman B, Liu T, Gustavsson S. In vivo enhancement of the specific antibody response via the low-affinity receptor for IgE. *Eur J Immunol* 1993;23:1739–42.
  123. Fujiwara H, Kikutani H, Suematsu S, Naka T, Yoshida K, Yoshida K, et al. The absence of IgE antibody-mediated augmentation of immune responses in CD23-deficient mice. *Proc Natl Acad Sci U S A* 1994;91:6835–9.
  124. Gustavsson S, Wernersson S, Heyman B. Restoration of the antibody response to IgE/antigen complexes in CD23-deficient mice by CD23+ spleen or bone marrow cells. *J Immunol* 2000;164:3990–5.
  125. Sherr E, Macy E, Kimata H, Gilly M, Saxon A. Binding the low affinity FcεRI on B cells suppresses ongoing human IgE synthesis. *J Immunol* 1989;142:481–9.
  126. Payet ME, Woodward EC, Conrad DH. Humoral response suppression observed with CD23 transgenics. *J Immunol* 1999;163:217–23.
  127. Payet-Jamroz M, Helm SL, Wu J, Kilmon M, Fakhri M, Basalp A, et al. Suppression of IgE responses in CD23-transgenic animals is due to expression of CD23 on nonlymphoid cells. *J Immunol* 2001;166:4863–9.
  128. Yu P, Kosco-Vilbois M, Richards M, Kohler G, Lamers MC. Negative feedback regulation of IgE synthesis by murine CD23. *Nature* 1994;369:753–6.
  129. Cernadas M, De Sanctis GT, Krinzman SJ, Mark DA, Donovan CE, Listman JA, et al. CD23 and allergic pulmonary inflammation: potential role as an inhibitor. *Am J Respir Cell Mol Biol* 1999;20:1–8.
  130. Haczk A, Takeda K, Hamelmann E, Loader J, Joetham A, Redai I, et al. CD23 exhibits negative regulatory effects on allergic sensitization and airway hyperresponsiveness. *Am J Respir Crit Care Med* 2000;161(3 Pt 1):952–60.
  131. Haczk A, Takeda K, Hamelmann E, Oshiba A, Loader J, Joetham A, et al. CD23 deficient mice develop allergic airway hyperresponsiveness following sensitization with ovalbumin. *Am J Respir Crit Care Med* 1997;156:1945–55.
  132. Riffo-Vasquez Y, Spina D, Thomas M, Gilbey T, Kemeny DM, Page CP. The role of CD23 on allergen-induced IgE levels, pulmonary eosinophilia and bronchial hyperresponsiveness in mice. *Clin Exp Allergy* 2000;30:728–38.
  133. Saxon A, Kurbe LM, Behle K, Max EE, Zhang K. Inhibition of human IgE production via FcεRII stimulation results from a decrease in the mRNA for secreted but not membrane εH chains. *J Immunol* 1991;147:4000–6.
  134. Uchibayashi N, Kikutani H, Barsumian EL, Hauptmann R, Schneider FJ, Schwendenwein R, et al. Recombinant soluble FcεRII (FcεRII/CD23) has IgE binding activity but no B cell growth promoting activity. *J Immunol* 1989;142:3901–8.
  135. Schulz O, Sutton BJ, Beavil RL, Shi J, Sewell HF, Gould HJ, et al. Cleavage of the low-affinity receptor for human IgE (CD23) by a mite cysteine protease: nature of the cleaved fragment in relation to the structure and function of CD23. *Eur J Immunol* 1997;27:584–8.
  136. Gough L, Schulz O, Sewell HF, Shakib F. The cysteine protease activity of the major dust mite allergen Der p 1 selectively enhances the immunoglobulin E antibody response. *J Exp Med* 1999;190:1897–902.
  137. Mayer RJ, Bolognese BJ, Al-Mahdi N, Cook RM, Flamberg PL, Hansbury MJ, et al. Inhibition of CD23 processing correlates with inhibition of IL-4-stimulated IgE production in human PBL and hu-PBL-reconstituted SCID mice [see comments]. *Clin Exp Allergy* 2000;30:719–27.
  138. Christie G, Barton A, Bolognese B, Buckle DR, Cook RM, Hansbury MJ, et al. IgE secretion is attenuated by an inhibitor of proteolytic processing of CD23 (FcεRII). *Eur J Immunol* 1997;27:3228–35.

# Inflammatory and Effector Cells/Cell Migration

BENJAMIN P. DAVIS | MARC E. ROTHENBERG

## KEY POINTS

- A hallmark of allergic inflammation is the accumulation of a large number of leukocytes, including eosinophils, neutrophils, lymphocytes, basophils and macrophages, in the inflammatory tissues.
- Leukocyte migration into tissues is regulated by chemokines, chemoattractive cytokines.
- Th2 cytokines (e.g. interleukin [IL]-4 and IL-13) are potent inducers of allergy-associated chemokines (e.g. eotaxin).
- Chemokines are potent cellular activating factors.
- Leukocytes bind to the endothelium via low-affinity reversible interactions mediated by selectins, and tight adhesion of leukocytes to endothelium is mediated by specific adhesion molecules such as integrins.
- Animal and human experimental systems have demonstrated that allergic inflammatory responses are often biphasic.

## Introduction

One of the hallmarks of allergic inflammation is the accumulation of an abnormally large number of leukocytes, including eosinophils, neutrophils, lymphocytes, basophils and macrophages, in the inflammatory tissue. There is substantial evidence that inflammatory cells are major effector cells in the pathogenesis of allergic disorders. Therefore, understanding the mechanisms by which leukocytes accumulate and are activated in tissues is very relevant to allergic diseases. Substantial progress has been made in understanding the specific molecules involved in leukocyte migration and the specific mechanisms by which effector cells participate in disease pathogenesis. In particular, cellular adhesion proteins, integrins and chemoattractant cytokines (chemokines) have emerged as critical molecules in these processes. Chemokines are potent leukocyte chemoattractants and cellular activating factors, making them attractive new therapeutic targets for the treatment of allergic disease. This chapter focusses on recently emerging data on the mechanisms by which specific leukocyte subsets are recruited into allergic tissues and how leukocytes participate in disease pathogenesis.

Animal and human experimental systems have demonstrated that allergic inflammatory responses are often biphasic. For example, asthma is characterized by a biphasic bronchospasm response, consisting of an early-phase asthmatic response (EAR) and a late-phase asthmatic response (LAR)<sup>1</sup> (Figure 5-1).

The EAR is characterized by immediate bronchoconstriction in the absence of pronounced airway inflammation or morphologic changes in the airway tissue.<sup>1,2</sup> The EAR has been shown to directly involve immunoglobulin (Ig) E/mast cell-mediated release of histamine, prostaglandin D<sub>2</sub> and cysteinyl-peptide leukotrienes (CysLTs), which are potent mediators of bronchoconstriction. After the immediate response, individuals with asthma often experience an LAR, which is characterized by persistent bronchoconstriction associated with extensive airway inflammation and morphologic changes to the airways.<sup>1,3-5</sup> Clinical investigations have demonstrated that the LAR is associated with increased levels of inflammatory cells, in particular activated T lymphocytes and eosinophils (Figure 5-1). The elevated levels of T lymphocytes and eosinophils correlate with increased levels of eosinophilic constituents in the bronchoalveolar lavage fluid (BALF), the degree of airway epithelial cell damage, enhanced bronchial responsiveness to inhaled spasmogens and disease severity.<sup>1,4-8</sup> In this chapter, we concentrate on understanding the inflammatory cells that participate in allergic responses, the mechanisms involved in their accumulation in natural human allergic responses and in experimental models, such as the biphasic response described above (Figure 5-1), and the complex interplay of these diverse cells with resident cells including endothelial, epithelial, smooth muscle cells and fibroblasts.<sup>9-11</sup>

## Myelocytes

### EOSINOPHILS

Eosinophils are multifunctional leukocytes implicated in the pathogenesis of numerous inflammatory processes, especially allergic disorders.<sup>12</sup> In addition, eosinophils play a role in homeostasis and may have a physiologic role in organ morphogenesis (e.g. postgestational mammary gland development) and the development of immune architecture, particularly the formation and function of IgA-secreting B cells.<sup>13,14</sup> The gastrointestinal (GI) tract, spleen, lymph nodes, thymus, mammary glands and uterus are rich in eosinophils.<sup>15,16</sup> In adipose tissue, eosinophils are important for the maintenance of glucose metabolic homeostasis.<sup>17</sup> Additionally, experimental eosinophil accumulation in the GI tract is associated with the development of weight loss, which is attenuated in eotaxin-deficient mice that have a deficiency in GI eosinophils.<sup>18</sup> It is important to note that recent attention has focussed on the key role of innate helper lymphoid cells (ILC), particularly ILC2, in regulating eosinophils via production of interleukin (IL)-5 and IL-13, and this regulation is related to nutritional intake in the GI tract.<sup>19</sup>

Eosinophils express numerous receptors for chemokines (e.g. eotaxin, an eosinophil-selective chemoattractant) that,

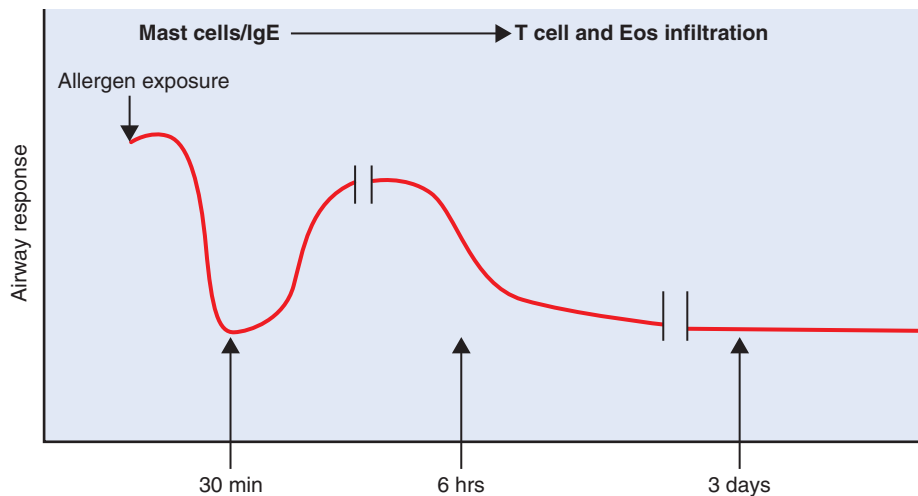

**Figure 5-1** Early-phase and late-phase allergic responses. The airway response (e.g. forced expiratory volume in the first second [FEV<sub>1</sub>]) is illustrated for when an allergen-sensitized individual is experimentally exposed to an allergen. A biphasic bronchospasm response, consisting of an early-phase asthmatic response (EAR) and a late-phase asthmatic response (LAR), is shown. The EAR phase is characterized by immediate bronchoconstriction in the absence of pronounced airway inflammation or morphologic changes in the airways tissue. The EAR phase has been shown to directly involve IgE/mast cell-mediated release of histamine, prostaglandin D<sub>2</sub> and cysteinyl-peptide leukotrienes, which are potent mediators of bronchoconstriction. After the immediate response, the airway recovers but later undergoes marked decline in function, which is characterized by more persistent bronchoconstriction associated with extensive airway inflammation (involving T cells and eosinophils [Eos]).

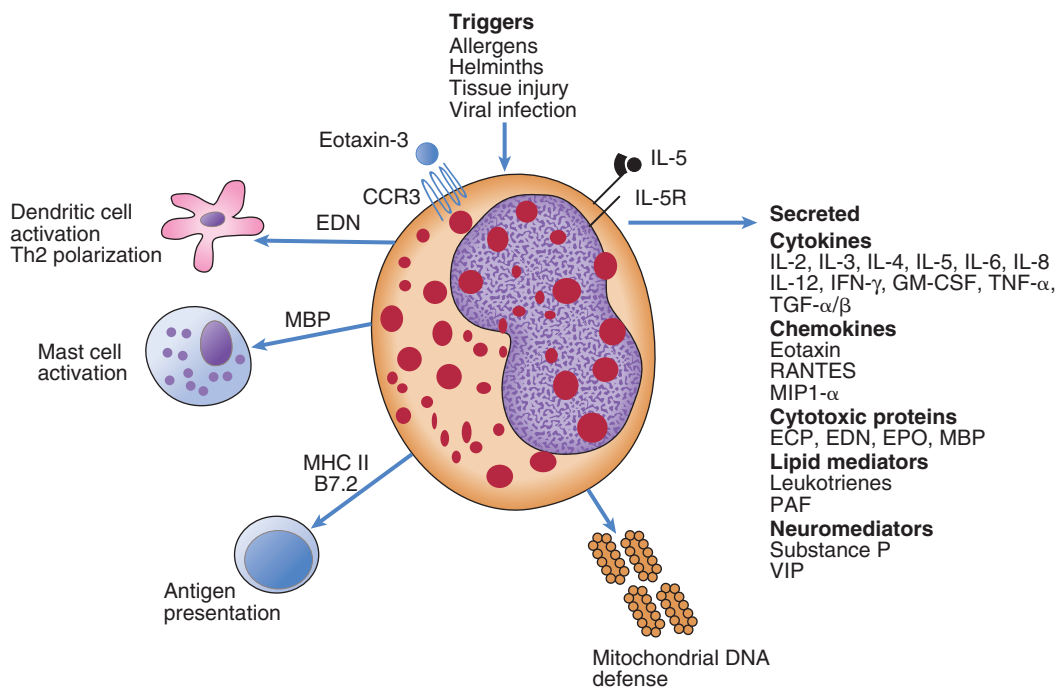

**Figure 5-2** Schematic diagram of an eosinophil and its diverse properties. Eosinophils are bilobed granulocytes that respond to diverse stimuli including allergens, helminths, viral infections, allografts and nonspecific tissue injury. Eosinophils express the receptor for IL-5, a critical eosinophil growth and differentiation factor, as well as the receptor for eotaxin and related chemokines (CCR3). The secondary granules contain four primary cationic proteins designated eosinophil peroxidase (EPO), major basic protein (MBP), eosinophil cationic protein (ECP) and eosinophil-derived neurotoxin (EDN). All four proteins are cytotoxic molecules; also, ECP and EDN are ribonucleases. In addition to releasing their preformed cationic proteins, eosinophils can release a variety of cytokines, chemokines and neuromediators and generate large amounts of LTC<sub>4</sub>. Lastly, eosinophils can be induced to express MHC class II and costimulatory molecules and may be involved in propagating immune responses by presenting antigen to T cells.

when engaged, lead to eosinophil activation, resulting in several processes, including the release of toxic secondary granule proteins<sup>20</sup> (Figure 5-2). The secondary granule contains a crystalloid core composed of major basic protein (MBP) and a granule matrix that is mainly composed of eosinophil cationic protein (ECP), eosinophil-derived neurotoxin (EDN) and eosinophil

peroxidase (EPO). These granule proteins have been shown to be cytotoxic, helminthotoxic and virotoxic.<sup>15,16,21</sup> Importantly, an anti-eotaxin antibody (berilimumab) has been shown to decrease nasal congestion with a trend of decreased eosinophils in allergic rhinitis and is being studied currently for another eosinophil-related condition, ulcerative colitis.<sup>22</sup>

Activation of eosinophils also leads to the generation of large amounts of LTC<sub>4</sub>, which induces increased vascular permeability, mucus secretion and smooth muscle constriction.<sup>23</sup> Also, activated eosinophils generate a wide range of cytokines including IL-1, IL-3, IL-4, IL-5 and IL-13; GM-CSF; transforming growth factor (TGF)- $\alpha/\beta$ ; tumor necrosis factor (TNF)- $\alpha$ ; RANTES (regulated on activation, normal T cells expressed and secreted); macrophage inflammatory protein (MIP)-1 $\alpha$ ; and eotaxin. This indicates that they have the potential to sustain or augment multiple aspects of the immune response, inflammatory reaction and tissue repair processes.<sup>24</sup> Eosinophils also have the capacity to initiate antigen-specific immune responses by acting as antigen-presenting cells. Consistent with this role, eosinophils express relevant costimulatory molecules (CD40, CD28, CD86, B7),<sup>25,26</sup> secrete cytokines capable of inducing T cell proliferation and maturation (IL-2, IL-4, IL-6, IL-10, IL-12)<sup>24,27,28</sup> and can be induced to express MHC class II molecules.<sup>27</sup> Interestingly, experimental adoptive transfer of antigen-pulsed eosinophils induces antigen-specific T cell responses *in vivo*<sup>29</sup> (Box 5-1). Finally, it has been shown that the GI eosinophils have a unique and fascinating innate effector response. It appears that eosinophils may eliminate invading bacteria by ejecting their mitochondrial DNA, which is encased in highly cationic proteins.<sup>30</sup> Evidence continues to emerge suggesting that eosinophils have an important role in innate immune responses, in addition to their well-established role in allergic disease.

Eosinophils are important for the development of asthma-associated airway hyperresponsiveness (AHR).<sup>15,16,31</sup> Eosinophils are the principal source of CysLTs and have been identified as the dominant source of leukotriene LTC<sub>4</sub> in asthmatic bronchial airway.<sup>32</sup> These leukotrienes can initiate mucus hypersecretion, AHR and edema. MBP is cytotoxic to airway epithelial cells and may be at least partly responsible for the tissue damage that is associated with eosinophil infiltration in bronchial mucosa in asthma and has been associated with fatal asthma.<sup>33</sup> Importantly, eosinophils have been implicated in the regulation of pulmonary T cell responses<sup>34</sup> and appear to be required for complete Type 2 T helper cell (Th2) cytokine production and allergen-induced mucus production in the lung.<sup>35</sup> Within the last few years, attempts have been made to further classify asthma phenotypes; one subtype is eosinophilic asthma, which is often a severe, steroid-refractory disease.<sup>36</sup> Eosinophils selectively express the receptor for IL-5, a cytokine that regulates eosinophil expansion and eosinophil survival and primes eosinophils to respond to appropriate activating signals. Multiple studies have supported the beneficial usage of anti-IL-5 therapy for patients with asthma<sup>16,37,38</sup> and nasal polyposis.<sup>39</sup> Moreover,

peripheral blood eosinophils and eosinophil granule protein levels are increased and correspond with disease activity in most patients with atopic dermatitis, and eosinophil granule proteins have been shown to be deposited in lesional skin.<sup>40</sup> Eosinophil accumulation in the GI tract is a common characteristic of numerous disorders, including gastroesophageal reflux disease (GERD), inflammatory bowel disease (IBD), drug reactions, helminthic infections, hypereosinophilic syndrome (HES), eosinophilic GI disorders (EGIDs) and allergic colitis.<sup>15,16,38</sup> EGIDs, including eosinophilic esophagitis (EoE), eosinophilic gastritis (EG) and eosinophilic gastroenteritis (EGE), often occur without peripheral blood eosinophilia, indicating the significance of GI-specific mechanisms for regulating local eosinophil levels. Although absent in the normal esophagus, eosinophils markedly accumulate in the esophagus of patients with EoE. A number of experimental models have provided evidence that eosinophils are key effector cells in EGIDs and contribute to the disease pathology.<sup>41</sup> In allergic rhinitis during allergy season, there is an increase in eosinophils and their granule proteins.<sup>42</sup> The above data collectively demonstrate the importance of eosinophils in allergic disease.

## MAST CELLS

Mast cells are normally present particularly in tissues in contact with the external environment (i.e. skin, respiratory mucosa, conjunctiva and GI mucosa). Mast cells contribute to immune responses to bacteria<sup>43</sup> and venom<sup>44</sup> and are important in homeostasis and wound repair.<sup>45</sup> Mast cells are major effector cells involved in allergic responses; in addition, they are important cytokine-producing cells that are involved in nonallergic processes such as the innate immune response (Figure 5-3). In contrast to other hematopoietic cells that complete their differentiation in the bone marrow, mast cell progenitors leave the bone marrow and complete their differentiation in tissues. Elegant studies in mice have demonstrated that development of mast cells from bone marrow cells is dependent on IL-3 and that their tissue differentiation is primarily dependent on stem cell factor (SCF).<sup>46-48</sup> In contrast to the mast cell culture

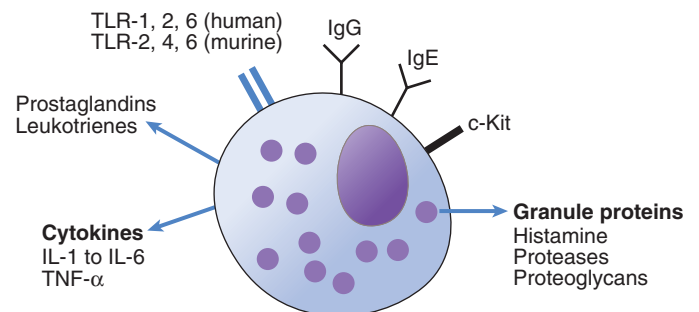

**Figure 5-3** Schematic diagram of a mast cell and its products. Mast cells are mononuclear cells that express high-affinity IgE receptors and contain a large number of metachromatic granules. Mast cells express c-Kit, the receptor for stem cell factor (SCF), a critical mast cell growth and differentiation factor. The secondary granule of a mast cell also contains abundant levels of proteases, proteoglycans and histamine. In addition to releasing their preformed proteins, mast cells can also release a variety of cytokines and generate large amounts of prostaglandins (PGD<sub>2</sub>) and leukotrienes (LTC<sub>4</sub>). Mast cells also express Toll-like receptors (TLR), indicating that mast cells participate during innate immune responses.

### BOX 5-1 KEY CONCEPTS

#### Eosinophils

- Eosinophils are multifunctional leukocytes that normally account for 1% to 3% of circulating leukocytes.
- Eosinophils normally reside in mucosal tissues such as the gastrointestinal tract.
- Eosinophil granules contain cationic (basic) proteins that are cytotoxic to a variety of host tissues (e.g. respiratory epithelium).
- Eosinophil expansion is regulated by the growth factor IL-5.
- Eosinophil tissue mobilization is regulated by the eotaxin subfamily of chemokines.



conditions in the murine system (which depend on IL-3), mature human mast cells are obtained by culturing progenitor cells with SCF, IL-6 and IL-10. Furthermore, treatment of mature human mast cells with IL-4 induces further maturation, including enhancing their capacity for IgE-dependent activation and their enzymatic machinery for synthesizing PGD<sub>2</sub> and CysLTs.<sup>49</sup>

Mast cells exist as heterogeneous populations depending on the tissue microenvironment in which they reside and on the immunologic status of the individual. In work with rodents, the terms *mucosal mast cell* (MMC) and *connective tissue mast cell* (CTMC) have emerged, but designating these two populations of mast cells by tissue location alone is an oversimplification. In general, MMCs express less sulfated proteoglycans (chondroitin sulfate) in their granules than CTMCs and hence have different staining characteristics with metachromatic stains. In addition, mast cell populations express distinct granule proteases; in humans, the mast cell nomenclature is based on neutral protease expression. Human cells that express only tryptase (MC<sub>T</sub>) are distinguished from mast cells that express tryptase, chymase, carboxypeptidase and cathepsin G (MC<sub>TC</sub>). In normal tissues, MC<sub>T</sub> cells are the predominant cells in the lung and small intestinal mucosa, whereas MC<sub>TC</sub> cells are the predominant types found in the skin and GI submucosa.

Mast cell activation occurs through several pathways. Classically, a multivalent allergen cross-links IgE molecules bound to the high-affinity IgE receptor (FcεRI). Mast cells undergo regulated exocytosis of their granules, resulting in the release of preformed mediators; in addition, activated mast cells undergo de novo synthesis and release of a variety of potent mediators (such as prostaglandin D<sub>2</sub> and LTC<sub>4</sub>). Preformed mediators in mast cells include biogenic amines such as histamine (a vasodilator), various neutral proteases, a variety of cytokines, acid hydrolases (e.g. β-hexosaminidase) and proteoglycans. Notably, nearly 20% of the protein of human mast cells is composed of tryptase, a proinflammatory protease with a wide range of activities (e.g. cleavage of complement proteins).<sup>50</sup> Mast cells store a variety of cytokines in their granules (e.g. TNF-α, IL-1, IL-4, IL-5 and IL-6 and chemokines including IL-8) and, after activation with allergens or cytokines, mast cells can increase their synthesis and secretion of these cytokines.<sup>51</sup>

It is well established that mast cell products contribute to the immediate allergic responses in asthma,<sup>52</sup> anaphylaxis,<sup>52</sup> allergic rhinoconjunctivitis<sup>53</sup> and urticaria.<sup>54</sup> There is also evidence that mast cells can contribute to allergic sensitization via IL-4-mediated skewing of T cells toward the Th2 phenotype<sup>55</sup> via a mechanism involving dendritic cell activation of T cells.<sup>56–59</sup>

The contribution of mast cell products such as cytokines has been less clear, though mast cells appear to be a chief source of TNF-α in asthmatic lung (Box 5-2). In addition, mast cells have been shown to contribute to the chronic inflammation associated with the LAR in experimental asthma.<sup>52</sup> The LAR also responds dramatically to omalizumab therapy,<sup>60</sup> suggesting that LAR is initiated by mast cell activation during the EAR. Additionally, mast cells have been linked to more chronic, T cell-mediated allergic diseases such as atopic dermatitis<sup>61</sup> and EoE.<sup>62</sup>

## BASOPHILS

Basophils are hematopoietic cells that arise from a granulocyte-monocyte progenitor (GMP) that shares its lineage with mast cells and eosinophils.<sup>63</sup> Basophils complete their development in

### BOX 5-2 KEY CONCEPTS

#### Mast Cells

- Mast cells are bone marrow-derived, tissue-dwelling cells.
- Mast cells do not normally exist in the circulation.
- Mast cell development is critically dependent on the cytokine stem cell factor and its receptor c-Kit.
- Mast cells express a high-affinity IgE receptor (FcεR) that is normally occupied with IgE.
- Mast cell activation results in the release of preformed mediators (e.g. histamine and proteases) and newly synthesized mediators such as prostaglandins and leukotrienes.
- Mast cells also produce cytokines such as tumor necrosis factor (TNF)-α and have an important role in innate immune responses (e.g. by attracting neutrophils).

### BOX 5-3 KEY CONCEPTS

#### Basophils

- Basophils are bone marrow leukocytes that normally account for less than 2% of circulating leukocytes.
- Basophils express the high-affinity IgE receptor FcεR.
- Basophils are distinguished from mast cells by their separate lineage, bilobed nuclei and distinct granule proteins.
- Basophils accumulate in tissues during late-phase responses.

the bone marrow and circulate as mature cells, representing less than 2% of blood leukocytes (Box 5-3). Similar to mast cells, basophils express substantial levels of FcεRI and store histamine in their granules. They are distinguished from mast cells by their segmented nuclei, ultrastructural features, growth factor requirements, granule constituents and surface marker expression (c-Kit<sup>+</sup>, FcεRI<sup>+</sup>).<sup>64</sup> Basophils are more readily distinguished from eosinophils microscopically due to differences in their nuclei, cytoplasmic granules and appearance on hematoxylin- and eosin-stained tissues. In the human system, they develop largely in response to IL-3 in a process augmented by TGF-β. Mature basophils maintain expression of the IL-3 receptor, and IL-3 is a potent basophil-priming and -activating cytokine.<sup>65</sup>

Several processes activate basophils; upon cross-linking of their surface-bound IgE, basophils release preformed mediators including histamine and proteases and synthesize LTC<sub>4</sub>. In addition, they secrete cytokines such as IL-4 and IL-13; notably, the amount of IL-4 secreted by basophils compared with that by Th2 cells appears to be substantial.<sup>66</sup> Similar to eosinophils, basophils are also activated by IgA (via FcαR) and by CCR3 ligands. Basophils also express several other chemokine receptors, including CCR2, whose ligands are potent histamine-releasing factors. Basophils also express major histocompatibility complex (MHC) class II and costimulatory molecules CD80 and CD86 and may be an antigen-presenting cell that can induce Th2 cell differentiation in the lymph node via IL-4.<sup>67–69</sup>

Recent murine studies suggest that basophils help to expel helminths.<sup>70</sup> Additionally, other animal models have suggested that basophils participate in the resistance of ectoparasitic ticks.<sup>71</sup> Studies have linked basophils to the sensitization phase in EoE<sup>72</sup> and the late-phase response in allergic rhinitis, asthma and allergic contact dermatitis.<sup>73–76</sup> Basophils have also been implicated in a unique IgG-mediated mechanism of anaphylaxis in mice. It appears that this mechanism of anaphylaxis is dependent upon IgG, macrophages and platelet-activating factor (PAF). Elegant mouse studies have demonstrated that

mice deficient in IgE, FcεRI and mast cells still experience anaphylaxis via an IgG-mediated process.<sup>77</sup> However, IgG-mediated anaphylaxis is abolished in basophil-deficient mice.<sup>78</sup> Further investigations are needed to define the role of basophils in this newly described anaphylactic pathway.

## MACROPHAGES

Macrophages are tissue-dwelling cells that originate from hematopoietic stem cells in the bone marrow and are subsequently derived from circulating blood monocytes.<sup>79</sup> Under healthy conditions, bone marrow colony-forming cells rapidly progress through monoblast and promonocyte stages to monocytes, which subsequently enter the bloodstream for about 3 days, where they account for about 5% of circulating leukocytes in most species. On entering various tissues, monocytes terminally differentiate into morphologically, histochemically and functionally distinct tissue macrophage populations that have the capacity to survive for several months.<sup>80</sup> Tissue-specific populations of macrophages include dendritic cells (skin, gut), Kupffer cells (liver) and alveolar macrophages (lung). Macrophage colony-stimulating factor (M-CSF) 1 promotes monocyte differentiation into macrophages, and mice with a genetic mutation in *Csf1* have a deficiency of tissue macrophages.<sup>81</sup> In addition, GM-CSF promotes the survival, differentiation, proliferation and function of myeloid progenitors, as well as the proliferation and function of macrophages.<sup>82</sup>

Tissue macrophages contribute to innate immunity by virtue of their ability to migrate, phagocytose and kill microorganisms and to recruit and activate other inflammatory cells. By expressing Toll-like receptor mediated pathogen-recognition molecules that induce the release of cytokines capable of programming adaptive immune responses, macrophages provide important links between innate and adaptive immunity.<sup>83</sup> Macrophages also express high- and low-affinity receptors for IgG (FcγRI/II) and complement receptors (CR1) that promote their activation. Activated macrophages produce a variety of pleiotropic proinflammatory cytokines such as IL-1, TNF-α and IL-8, as well as lipid mediators (e.g. leukotrienes and prostaglandins). Notably, macrophages express costimulatory molecules (e.g. CD86) and are potent antigen-presenting cells capable of efficiently activating antigen-specific T cells.

A substantial body of evidence has revealed that macrophages are critical effector cells in allergic responses. For example, peripheral blood monocytes from asthmatic individuals secrete elevated levels of superoxide anion and GM-CSF.<sup>84</sup> In addition, the lung tissue and BALF from asthmatic individuals have elevated levels of macrophages.<sup>85</sup> Consistent with this finding, the asthmatic lung overexpresses macrophage-attracting chemokines (e.g. mast cell protease [MCP]-1).<sup>86</sup> Additionally, there appear to be different types of lung macrophages based on tissue location. Alveolar macrophages promote an inflammatory response, whereas interstitial macrophages have decreased phagocytosis and increased antiinflammatory effect.<sup>87</sup> Alveolar macrophages have no antiinflammatory effect during the sensitization phase of lung immune responses,<sup>88</sup> whereas interstitial macrophages suppress responses against inhaled allergens.<sup>89</sup> Interstitial macrophages prevent Th2 polarization in response to inhaled antigens via an IL-10/dendritic cell mechanism.

We now recognize that there are at least two distinct subsets of macrophages, classically and alternatively activated

macrophages. Classically activated macrophages (M1) are associated with a proinflammatory response and are activated by Th1 cytokines, whereas alternatively activated macrophages, so named because they are activated in the presence of Th2 cytokines, are associated with the resolution of inflammation and tissue repair. Alternatively activated macrophages (M2) may serve as a link between the innate and adaptive immune system, and further investigation into their function in allergic disorders is needed. A central mechanism for the differentiation of these macrophage subsets is the metabolism of arginine via two competing pathways, depending on their cytokine polarization.<sup>90</sup> For example, interferon (IFN)-γ and lipopolysaccharide (LPS) augment the expression of inducible nitric oxide synthase (iNOS), which results in the production of NO as a product of arginine metabolism. NO is a potent smooth muscle relaxer and endothelial cell regulator. Alternatively, the treatment of macrophages with IL-4 or IL-13 induces the expression of arginase, which preferentially shunts arginine away from NO and thus promotes bronchoconstriction. Arginase metabolizes arginine into ornithine, a precursor for polyamines and proline, critical regulators of cell growth and collagen deposition, respectively. Both M1 and M2 macrophages have been reported in asthmatics.<sup>91–93</sup>

## NEUTROPHILS

Neutrophils are bone marrow-derived granulocytes and account for the largest proportion of cells in most inflammatory sites. Neutrophils develop in the bone marrow by the sequential differentiation of progenitor cells into myeloblasts, promyelocytes and then myelocytes, an ordered process regulated by growth factors such as GM-CSF. Granulocyte-CSF promotes the terminal differentiation of neutrophils, which normally reside in the bloodstream for only 6 to 8 hours. A significant pool of marginated neutrophils exists in select tissues,<sup>94</sup> allowing rapid mobilization of neutrophils in response to a variety of triggers (e.g. IL-8, LTB<sub>4</sub>, PAF).

Activated neutrophils have the capacity to release a variety of products at inflammatory sites, which may induce tissue damage. These products include those of primary (azurophilic), secondary (or specific) and tertiary granules, including proteolytic enzymes, oxygen radicals and lipid mediators (LTB<sub>4</sub>, PAF and thromboxane A<sub>2</sub>). Neutrophil granules contain more than 20 enzymes; of these, elastase, collagenase and gelatinase have the greatest potential for inducing tissue damage. Neutrophil-derived defensins, lysozyme and cathepsin G have well-defined roles in antibacterial defense. In fact, studies have suggested that the major function of superoxide release into the phagocytic vesicle is increasing the intravesicular concentration of H<sup>+</sup> and K<sup>+</sup>, permitting conditions for optimal protease-mediated bacterial killing.<sup>95</sup>

Although neutrophils are not the predominant cell type associated with allergic disorders, several studies have demonstrated a correlation and possible role for neutrophils in the pathogenesis of allergic disease.<sup>96</sup> Individuals who die within 1 hour of the onset of an acute asthma attack have neutrophil-dominant airway inflammation,<sup>97</sup> suggesting that neutrophils may have a pathogenic role in some clinical situations. Neutrophils in bronchial biopsy and induced sputum are more likely seen with severe asthma.

Patients with neutrophilic asthma appear to be less responsive to corticosteroids, and high doses of corticosteroids may

increase neutrophils by reducing apoptosis.<sup>98</sup> Another lung disease associated with asthma, allergic bronchopulmonary aspergillosis (ABPA), features neutrophilic inflammation and activation.<sup>99</sup> Numerous risk exposures are linked to neutrophilic inflammation, including environmental exposures such as air pollution, smoking, infection and endotoxin, and health-related exposures such as high-fat, low-antioxidant diets, obesity and inflammatory states. Two fairly specific neutrophil therapies (anti-CXCL8 and anti-CXCR2) have begun to show promise in treating neutrophilic airway inflammation.<sup>100,101</sup> Collectively, these data suggest an important role for neutrophils in the acute and chronic manifestations of allergen-induced asthma.

## DENDRITIC CELLS

Dendritic cells are unique antigen-presenting cells that have a pivotal role in innate and acquired immune responses. They are considered the quintessential antigen-presenting cells and are known for their ability to effect a primary immune response including allergen sensitization. These cells are also important in maintenance of allergic inflammation via propagation of effector responses. Dendritic cells originate in the bone marrow and subsequently migrate into the circulation before they assume tissue locations as immature dendritic cells, incidentally at locations where maximum allergen encounter occurs (e.g. skin, GI tract and airways). Immature dendritic cells are potent in antigen uptake, efficient in capturing pathogens and producers of potent cytokines (e.g. IFN- $\alpha$  and IL-12). By expressing pattern-recognition receptors, dendritic cells directly recognize a variety of pathogens. Immature dendritic cells express the CC chemokine receptor (CCR) 6 that binds to MIP-3 $\alpha$  and  $\beta$ -defensin, which are produced locally in tissues such as those in the lung.<sup>102</sup> After antigen uptake, dendritic cells rapidly cross into the lymphatic vessels and migrate into draining secondary lymphoid tissue. During this migration, the dendritic cells undergo maturation, which is characterized by down-regulation of their antigen-capturing capacity, up-regulation of their antigen-processing and -presenting capabilities, and up-regulation of CCR7, which likely promotes dendritic cell recruitment to secondary lymphoid organs (which express CCR7 ligands).<sup>103</sup> After presentation of antigen to antigen-specific T cells in the T cell-rich areas of secondary lymphoid organs, dendritic cells mainly undergo apoptosis.

Dendritic cells are composed of heterogeneous populations based on ultrastructural features, surface molecule expression and function. In human blood, dendritic cells are divided into three types comprising two myeloid-derived subpopulations and one lymphoid-derived population (plasmacytoid dendritic cells).<sup>104</sup> The myeloid populations can be divided into CD1<sup>+</sup> and CD1<sup>-</sup>. CD1 is a molecule involved in the presentation of glycolipids to T cells. CD1<sup>+</sup> myeloid dendritic cells also express high levels of CD11c (complement receptor 4 [iC3b receptor]) and include interstitial and Langerhans dendritic cells; a skin-specific, self-renewing specialized dendritic cell; and inflammatory dendritic cells. CD1<sup>-</sup> myeloid dendritic cells are identified by CD141 expression and are cross-presenting dendritic cells.<sup>105</sup> The plasmacytoid dendritic cell population is CD1<sup>c</sup>/CD11<sup>c</sup> but is distinguished by its high levels of IL-3 receptor expression. This population of dendritic cells appears to be a primary source of IFN- $\alpha$ . Dendritic cells can be cultured from freshly isolated human cord or peripheral blood; myeloid dendritic

cells are primarily derived in response to stimulation with GM-CSF, TNF- $\alpha$  and IL-4; plasmacytoid dendritic cells develop in culture with IL-3. Monocyte-derived dendritic cells give rise to inflammatory dendritic cells that have a potent stimulatory capacity toward naive CD4<sup>+</sup> T cells and the ability to cross-present antigen to CD8<sup>+</sup> T cells and to produce key inflammatory cytokines including IL-1, IL-6, TNF- $\alpha$ , IL-12 and IL-23.<sup>105</sup>

Dendritic cells can influence Th cell differentiation (Figure 5-4). There is evidence that the same population of dendritic cells can influence Th1 and Th2 differentiation depending on several factors. For example, the ratio between dendritic cells and T cells has profound effects on influencing Th1 and Th2 differentiation.<sup>106</sup> In addition, Th1-polarized effector dendritic cells induce Th1 responses, whereas Th2-polarized dendritic cells induce Th2 responses.<sup>104</sup> Also, plasmacytoid dendritic cells stimulated first with IL-3 and then with CD40 ligand (before adding naive T cells) induce strong Th1 responses but no Th2 cytokine production. MicroRNA (miR)-21 expression in dendritic cells targets IL-12p23; hence, up-regulation of miR-21 by Th2 cytokines introduces a Th2-generating propagation loop. Finally, dendritic cells that express specific costimulatory molecules may promote distinct Th differentiation; for example, expression of B7-related protein (ICOS ligand) promotes Th2 development.<sup>107</sup>

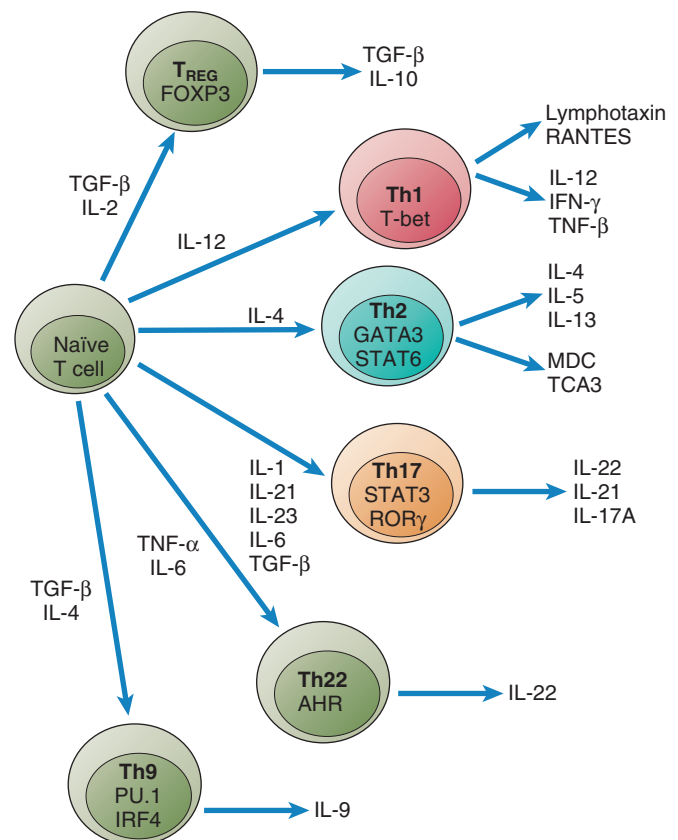

**Figure 5-4** T helper subsets. All currently recognized T helper subsets have been implicated in allergic disease. Th0 cells differentiate into T regulatory (T<sub>REG</sub>), Th1, Th2, Th9, Th17 or Th22 cells after their activation by antigen-presenting cells in the context of their respective promoting cytokines as noted. The unique transcription factors responsible for driving cytokine development are identified. AHR – Aryl hydrocarbon receptor.



**BOX 5-4 KEY CONCEPTS****Dendritic Cells**

- Dendritic cells normally exist as tissue surveillance cells.
- On contact with antigen (e.g. invading pathogen), dendritic cells migrate via lymphatics to secondary lymphoid organs.
- Immature dendritic cells are chief sources of innate cytokines (e.g. interferon [IFN]- $\alpha$ ).
- Mature dendritic cells are potent antigen-presenting cells.
- Dendritic cells can preferentially activate T subset responses.

Dendritic cells likely have critical roles in the development of allergic responses. Current evidence and theory suggest that allergen can induce a Th2-mediated response, either alone (with a self-adjuvant effect) or in combination with other environmental adjuvants (viral or bacterial infections or air pollution),<sup>108</sup> and that this effect likely occurs via communication of resident stromal cells and dendritic cells.<sup>109,110</sup> Pollen allergens *in vitro* have been shown to induce a Th2-polarizing dendritic cell,<sup>111</sup> whereas house dust mite-mediated dendritic cell polarization is dependent on the allergy background of the patient.<sup>112,113</sup> Dendritic cells are required for the development of eosinophilic airway inflammation in response to inhaled antigen.<sup>114</sup> Importantly, adoptive transfer of antigen-pulsed dendritic cells has been shown to be sufficient for the induction of Th2 responses and eosinophilic airway inflammation to inhaled antigen.<sup>103,115</sup> Elevated levels of CD1a<sup>+</sup>/MHC class II<sup>+</sup> dendritic cells are found in the lung of atopic asthmatics compared with nonasthmatics<sup>103</sup> (Box 5-4).

In addition to the importance of dendritic cells in sensitization, selective depletion of dendritic cells during allergen challenge in both asthma and allergic rhinitis murine models has demonstrated the importance of dendritic cells in the effector phase of these diseases.<sup>116,117</sup> Fc $\epsilon$ RI expression on dendritic cells in humans and mice in asthma and atopic dermatitis is correlated with increased Th2 effector response.<sup>118–120</sup>

**LYMPHOCYTES**

Lymphocytes are integral to the development of a complete innate and adaptive immune response. One important function of lymphocytes is to generate adaptive immune responses and to develop a memory compartment for future responses. Innate lymphocytes serve as sentinel cells in epithelial-associated tissues, providing prompt release of cytokines that help to form the adaptive response. Lymphocytes both aid in pathogen defense and facilitate allergic disease. In addition to Th2 cells, many lymphocytes can participate in allergic inflammation including Th1 cells, Th17 cells, CD8<sup>+</sup> T cells, B cells,  $\gamma/\delta$  T cells, natural killer (NK) cells and natural killer T (NKT) cells.

**T CELLS**

T cells are specialized leukocytes distinguished by their expression of antigen-specific receptors that arise from somatic gene rearrangement. Two major subpopulations were originally defined on the basis of the expression of the CD4 and CD8 antigens and their associated function. CD4<sup>+</sup> T cells recognize antigen in association with MHC class II molecules on antigen-presenting cells, including dendritic cells, B cells and macrophages, and are primarily involved in orchestrating immune

responses, whereas CD8<sup>+</sup> T cells recognize antigen in association with MHC class I molecules and are primarily involved in cytotoxicity. Class I MHC molecules are present on the surface of all nucleated cells, and their antigens are typically intracellularly derived. More recently, populations of regulatory T cells have been characterized. Regulatory T cells are commonly identified as CD4<sup>+</sup>/CD25<sup>+</sup>/FOXP3<sup>+</sup> T cells; these cells are chief sources of regulatory cytokines, including IL-4 and IL-10, and are thought to participate in tolerance induction after allergen immunotherapy.<sup>121</sup> The absence of or decrease in the function of T regulatory cells leads to an increase in activity of effector T lymphocytes and is associated with the development of autoimmunity.<sup>122</sup> CD4<sup>+</sup> T lymphocytes have central roles in allergic responses by regulating the production of IgE and the effector function of mast cells and eosinophils.<sup>123</sup>

CD4<sup>+</sup> Th1-type T lymphocytes produce IL-2, TNF- $\beta$  (lymphotoxin) and IFN- $\gamma$  and are involved in delayed-type hypersensitivity responses. Th2 lymphocytes secrete IL-4, IL-5, IL-9, IL-10 and IL-13 and promote antibody responses and allergic inflammation (Figure 5-4). Notably, there is a strong correlation between the presence of CD4<sup>+</sup> Th2 lymphocytes and disease severity, suggesting an integral role for these cells in the pathophysiology of allergic diseases.<sup>124,125</sup> Th2 cells are thought to induce asthma through the secretion of cytokines that activate inflammatory and residential effector pathways both directly and indirectly.<sup>126</sup> The major T cell subset in allergic disease is Th2, but other subsets, such as Th1, CD8<sup>+</sup>, Th9, Th17 and Th22, also participate, especially in severe disease.<sup>127–129</sup> In fact, Th17 cells appear to be a critical component of the neutrophilic inflammation associated with severe asthma.<sup>130</sup>

Th2-associated cytokines, IL-4 and IL-13, are produced at elevated levels in the allergic tissue and are thought to be central regulators of many of the hallmark features of the disease.<sup>131</sup> However, in addition to Th2 cells, inflammatory cells within the allergic tissue also produce IL-4, IL-13 and a variety of other cytokines.<sup>20,24</sup> IL-4 promotes Th2 cell differentiation, IgE production, tissue eosinophilia and, in the case of asthma, morphologic changes to the respiratory epithelium and AHR.<sup>132</sup> IL-13 induces IgE production, mucus hypersecretion, eosinophil recruitment and survival, AHR and the expression of CD23, adhesion systems and chemokines.<sup>131,133,134</sup> A critical role for IL-13 in orchestrating experimental asthma has been suggested by the finding that a soluble IL-13 receptor homolog blocks many of the essential features of experimental asthma.<sup>135,136</sup> Furthermore, mice deficient in the IL-4R $\alpha$  chain have impaired eosinophil recruitment and mucus production but still develop AHR.<sup>137</sup>

Collectively, these studies have provided the rationale for the development of multiple therapeutic agents that interfere with specific inflammatory pathways. Additionally, as noted above, another important Th2-produced cytokine, IL-5, is important for eosinophil proliferation, survival and activation, and its inhibition has been linked to improved asthma and nasal polypoidosis (Box 5-5).

**B CELLS**

B cells play a key role in humoral allergic response through IgE production. Lymph nodes are the major anatomic structure of antigenic B cell education or affinity maturation. After these processes, B cells then become either memory B cells or antibody-producing plasma cells. IgE synthesis is regulated by



**BOX 5-5 KEY CONCEPTS****T Cells**

- Mature T cells are primarily divided into CD4<sup>+</sup> and CD8<sup>+</sup> cells.
- T cells express antigen-specific T cell receptors (TCR) that recognize antigen in the context of major histocompatibility molecules (MHC).
- CD4<sup>+</sup> T cells are engaged by antigen in the context of class II molecules.
- CD4<sup>+</sup> T cells subsets include Th1, Th2, Th9, Th17, Th22 and T<sub>REG</sub> cells.
- Th1 cells are major producers of Th1 cytokines (e.g. interferon [IFN]- $\gamma$ ), and Th2 cells are major producers of Th2 cytokines (e.g. IL-4, IL-5, IL-13). Newly discovered subsets include Th9, Th17 and Th22, which are major producers of IL-9, IL-17A and IL-22, respectively.

IL-4 and IL-13 and may be augmented by IL-9. B cells also are found in gut lymphoid tissue and localized in diseased epithelial tissue.<sup>138</sup> In allergic rhinitis, asthma and EoE, localized epithelial B cells produce C $\epsilon$  germ-line transcripts, as well as IL-4 and IL-13.<sup>139,140</sup> Additionally, MHC class II-expressing B cells can function as antigen-presenting cells and drive Th2 cells.<sup>141</sup>

**NATURAL KILLER CELLS**

NK cells lack rearranged antigen receptors and are considered part of the innate immune system. They produce high levels of IFN- $\gamma$  early during infection and directly kill virally infected cells by release of cytotoxic granules and Fas ligand-induced cell death. Additionally, NK cells suppress Th2 allergic airway inflammation post respiratory syncytial virus.<sup>142</sup> However, NK cells have also been shown to produce IL-5 and have been associated with eosinophilic inflammation.<sup>143</sup>

**NATURAL KILLER T CELLS**

NKT cells are a population of CD1d-restricted T cells that express  $\alpha/\beta$  T cell receptor (TCR), have some NK cell receptors, and share similar cytotoxic mechanisms to NK cells. Invariant NKT (iNKT) cells have a narrow repertoire of TCRs and respond to glycolipid antigen. iNKT cells can promote IgE production and, via cytokine production, may impact Th2 differentiation in the respiratory tract; they accumulate in the airways of asthmatics and increase with antigen challenge or exacerbation.<sup>144</sup>

 **$\gamma/\delta$  T CELLS**

The  $\gamma/\delta$  T cells are a subset of T cells that have a TCR formed from  $\gamma$  and  $\delta$  chains rather than  $\alpha/\beta$  chains. The  $\gamma/\delta$  T cells reside in intraepithelial regions in the skin and mucosa and in lymphoid tissue. Intraepithelial  $\gamma/\delta$  T cells do not recognize antigen in the context of MHC but rather respond to nonprocessed antigens, including lipids and heat shock proteins.<sup>145</sup> They produce IFN- $\gamma$  and IL-4 in vivo in response to Th1- or Th2-stimulating pathogens, respectively.<sup>146</sup>  $\gamma/\delta$  T cells that produce IL-4, IL-5 and IL-13 have been isolated from asthmatic airways and increase in number after antigen challenge.<sup>147</sup> Interestingly, murine  $\gamma/\delta$  T cells appear to be important both in the generation of Th2 immunity and protection from Th2-mediated disease.<sup>147</sup>

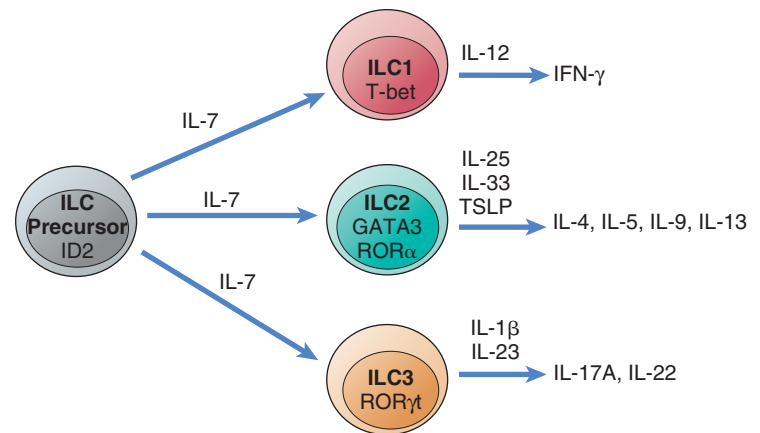

**Figure 5-5** Innate lymphoid cell subsets. Three main subtypes of innate lymphoid cells have been identified: ILC1, ILC2 and ILC3. They arise from a common precursor cell that expresses a transcription factor called inhibitor of DNA binding-2 (ID2). The unique cytokine profile and transcription factors responsible for driving cytokine development for the respective subsets are identified.

**INNATE LYMPHOID CELLS**

Populations of resident tissue lymphoid cells that lack B and T cell antigen receptors (BCR and TCR) and promote T helper cell development have been identified. These cells are lineage negative, meaning that they fail to express mature lymphocyte markers such as CD3, CD14, CD16, CD19, CD20 and CD56, but express high levels of stem cell markers such as CD117 (c-Kit). These cells are a small fraction of the total cell population in a given tissue but appear to be a major reservoir of T cell-skewing cytokines. Recently, it has been appreciated that these cells, like T helper cells, divide into subsets, and their nomenclature has been defined to reflect the cytokine and transcription factor similarity to their respective CD4<sup>+</sup> T cell subsets Th1, Th2 and Th17. The proposed subsets include ILC1, ILC2 and ILC3.<sup>148</sup>

ILC1s, like NK cells, are triggered by IL-12 to secrete high levels of IFN- $\gamma$  and are dependent on T-bet,<sup>149</sup> but unlike NK cells, they lack perforin and granzyme expression.<sup>150</sup> ILC2 cells were identified in lung, intestine and blood. They produce IL-4, IL-5 and IL-13 in response to stimulation with IL-25, IL-33 and thymic stromal lymphopoietin (TSLP) and are dependent on GATA3.<sup>151</sup> They are the first producers of IL-13 in the gut after helminth infection.<sup>152</sup> ILC2s have been shown to be important in multiple Th2-mediated allergic diseases, including asthma and atopic dermatitis.<sup>153,154</sup> As mentioned above, ILC2s are also important regulators of eosinophil homeostasis in the gut in a nutritionally dependent fashion.<sup>19</sup> ILC3s secrete IL-17A and IL-22 upon IL-23 stimulation and are dependent on ROR $\gamma$ t.<sup>155</sup> The role of these cells in relation to specific disease phenotypes is being actively investigated (Figure 5-5).

**Leukocyte Recruitment**

The trafficking of leukocytes into various tissues is regulated by a complex network of signaling events between leukocytes in the circulation and endothelial cells lining blood vessels. After injury or infection, resident cells at the site of injury or infection release chemokines, which interact via a gradient with the corresponding chemokine receptors on inflammatory cells. This

chemokine : chemokine receptor interaction is critical for both leukocyte extravasation from the bloodstream into the tissue and leukocyte navigation within tissue to the site of injury or infection. Because each type of leukocyte expresses a different array of chemokine receptors, the type of inflammation that develops in a given situation is highly dependent on the chemokines secreted by resident cells. These interactions involve a multistep process: (1) leukocyte rolling (mediated by endothelial selectin and specific leukocyte carbohydrate ligands), which exposes chemokine receptors on leukocytes to chemokines displayed on endothelial cells; (2) rapid activation of leukocyte integrins, in which chemokine receptor signaling induces an *inside-out* signaling in the leukocyte leading to integrin clustering on the cell surface and an increase in the integrin's affinity for its ligand; (3) firm adhesion between endothelial molecules and counterligands on leukocytes (via integrins); and (4) transmigration of leukocytes through the endothelial layer via junctional adhesion molecules (JAMs), platelet endothelial cell adhesion molecule (PECAM), CD99 and endothelial cell-selective adhesion molecule (ESAM) (Figure 5-6). This multistep signaling cascade must occur rapidly to allow for the leukocytes to reduce rolling velocity, mediate adherence and extravasate into tissues in response to a chemokine gradient. In addition to mediating leukocyte movement from the bloodstream into tissues, chemokines use similar steps to mediate leukocyte-directed motion across other tissue barriers, such as respiratory epithelium and the extracellular matrix (Box 5-6). Leukocyte adhesion deficiency (LAD) is a human disease associated with recurrent bacterial infections. The defect is in CD18, or  $\beta 2$  integrin, and results in the inability of neutrophils to be recruited from the blood to the site of infection.

### BOX 5-6 KEY CONCEPTS

#### Leukocyte Trafficking

- Leukocytes bind to the endothelium via low-affinity reversible interactions mediated by selectins.
- Tight adhesion of leukocytes to endothelium is mediated by specific adhesion molecules such as integrins (e.g.  $\beta 2$  integrins).
- Transmigration is mediated by PECAM, CD99, JAMs, and ESAM.
- Leukocyte migration into tissues is regulated by chemoattractants.

**Figure 5-6** Overview of leukocyte migration. The trafficking of leukocytes into various tissues is regulated by a complex network of signaling events between leukocytes in the circulation and endothelial cells lining blood vessels. These interactions involve a multistep process including (1) leukocyte rolling (mediated by endothelial selectin and specific leukocyte ligands), (2) rapid activation of leukocyte integrins by chemokines, (3) firm adhesion between endothelial molecules and activated integrins on leukocytes, and (4) transmigration of leukocytes through the endothelial layer via junctional adhesion molecules (JAMs), platelet endothelial cell adhesion molecule (PECAM), CD99 and endothelial cell-selective adhesion molecule (ESAM).

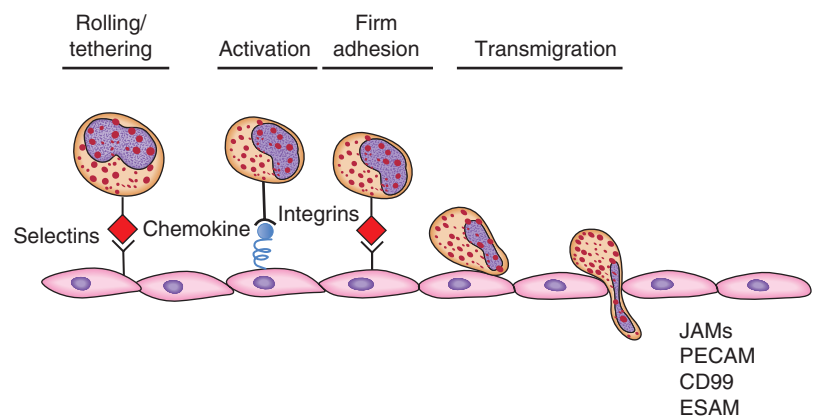

## CHEMOKINE AND CHEMOKINE RECEPTOR FAMILIES

Chemokines are the guiding signals that direct leukocytes to the site of injury or infection. Chemokines represent a large family of chemotactic cytokines that have been divided into four groups, designated CXC, CC, C and CX3C, on the basis of the spacing of conserved cysteines (Figure 5-7). These four families of chemokines are grouped into distinct chromosomal loci (Figure 5-7). The CXC and CC groups, in contrast to the C and CX3C groups, contain many members and have been studied in great detail. The CXC chemokines mainly target neutrophils, whereas the CC chemokines target a variety of cell types including macrophages, eosinophils and basophils. The current chemokine receptor nomenclature uses C, CXC, XC or CX3C (to designate chemokine group) followed by R (for receptor) and then a number. The new chemokine nomenclature substitutes the R for L (for ligand), and the number is derived from the one already assigned to the gene encoding the chemokine from the SCY (small secreted cytokine) nomenclature. Thus, a given gene has the same number as its protein ligand (e.g. the gene encoding eotaxin-1 is *SCYA11*, and the chemokine is referred to as CCL11). Table 5-1 summarizes the chemokine family using this nomenclature.<sup>156,157</sup> There have been seven CXC receptors identified, which are referred to as CXCR1 through CXCR7, and 11 human CC receptor genes cloned, which are known as CCR1 through CCR11 (Figure 5-8). The chemokine and leukocyte selectivities of chemokine receptors overlap extensively; a given leukocyte often expresses multiple chemokine receptors, and more than one chemokine typically binds to the same receptor (Figure 5-8), creating a scheme of redundancy and pleiotropy that ensures adequate leukocyte recruitment.

## CHEMOKINE RECEPTOR SIGNAL TRANSDUCTION

With nearly 1,000 members, the seven-transmembrane, G protein-coupled receptors (GPCRs) are universally employed to sense small changes in concentrations of molecules. The chemokine receptors are a subfamily of this GPCR superfamily. Chemokines induce leukocyte migration and activation by binding to specific GPCRs.<sup>156</sup> Although chemokine receptors are similar to many GPCRs, they have unique structural motifs such as the amino acid sequence DRYLAIV in the second intracellular domain.

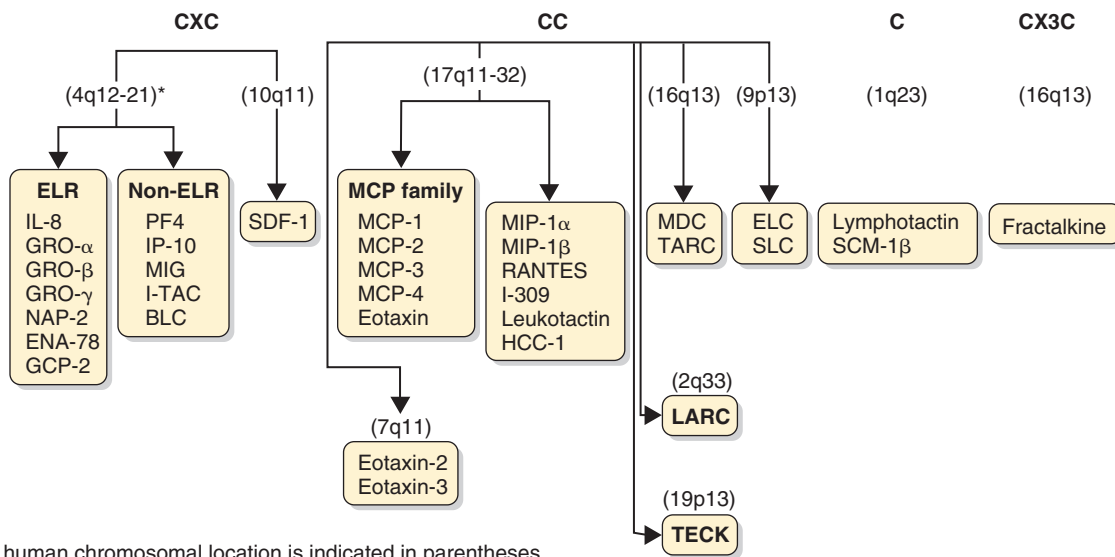

\*Position of human chromosomal location is indicated in parentheses.

**Figure 5-7** The human chemokine family.

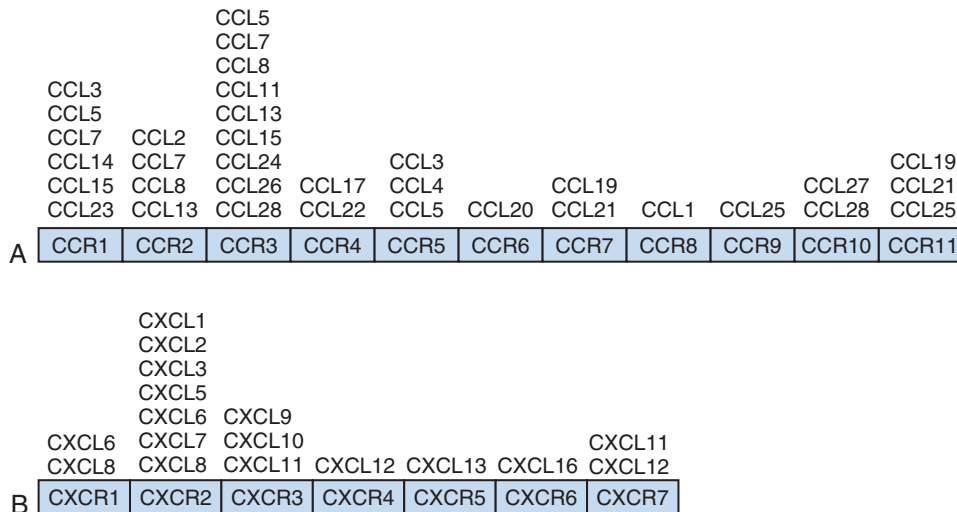

**Figure 5-8** Ligands for CC (A) and CXC (B) receptor families.

Receptor activation leads to a cascade of intracellular signaling events. In addition to triggering intracellular events, engagement with ligand induces rapid chemokine receptor internalization. Ligand-induced internalization of most chemokine receptors occurs independent of calcium transients, G protein coupling and protein kinase C, indicating a mechanism different from the one induced by chemotaxis. Thus, chemokine receptor internalization may provide a mechanism for chemokines also to halt leukocyte trafficking in vivo. There are many signaling pathways downstream of chemokine receptor binding. This heterogeneity of signaling pathways allows for different chemokine receptors, expressed on the same cell, to signal through distinct pathways and for the same chemokine receptor to induce a variety of effects.

**REGULATION OF CHEMOKINE AND CHEMOKINE RECEPTOR EXPRESSION**

The main stimuli for the secretion of chemokines are the early proinflammatory cytokines such as IL-1 and TNF- $\alpha$ , bacterial

products such as LPS and viral infection<sup>158-160</sup> (Figure 5-9). In addition, products of the adaptive arm of the immune system, including from both Th1 and Th2 cells, IFN- $\gamma$  and IL-4, respectively, also induce the production of chemokines independently and in synergy with IL-1 and TNF- $\alpha$ . Recently, it has been demonstrated that miRs also regulate chemokines. miR-21 regulates polarization of the adaptive immune response in asthma and is one of the most up-regulated in EoE.<sup>161</sup> It has also been correlated with increased CCL26 (eotaxin-3) and tissue eosinophilia in EoE.<sup>162</sup> Additionally, miR-21 has been shown to regulate keratinocyte-derived chemokine (KC),<sup>163</sup> CXCL10<sup>164</sup> and CCL20.<sup>165,166</sup> miR-155 is the most up-regulated miR in atopic dermatitis and regulates MCP-1,<sup>167</sup> CXCL8<sup>168</sup> and CCL2.<sup>169</sup>

Although there are many similarities in the regulation of chemokines, important differences that may have implications for asthma are beginning to be appreciated. For example, in the healthy lung, epithelial cells are the primary source of chemokines; however, in the inflamed lung, infiltrating cells within the submucosa are a major cellular source of chemokines.<sup>170</sup>

TABLE  
5-1

## Systematic Names for Human and Mouse Ligands

Systematic Name	Human Ligand	Mouse Ligand
<b>CXC FAMILY</b>		
CXCL1	GRO- $\alpha$ /MGSA- $\alpha$	GRO1/KC*
CXCL2	GRO- $\beta$ /MGSA- $\beta$	GRO- $\beta$ /MIP-2 $\alpha$
CXCL3	GRO- $\gamma$ /MGSA- $\gamma$	Dcip1/Gm1960
CXCL4	PF4	PF4
CXCL5	ENA-78	LIX
CXCL6	GCP-2	Ck $\alpha$ -3
CXCL7	NAP-2	CTAP3/LA-PF4/NAP-2
CXCL8	IL-8	?
CXCL9	Mig	Mig
CXCL10	IP-10	IP-10
CXCL11	I-TAC	I-TAC/Ip9
CXCL12	SDF-1 $\alpha$ / $\beta$	SDF-1
CXCL13	BLC/BCA-1	BLC/BCA-1
CXCL14	BRAK/bolekine	BRAK
CXCL15	?	Lungkine/Il-8
CXCL16	SCYB16/SRPSOX	SR-PSOX
CXCL17	VCC-1/DMC/SCYB17	VCC-1
<b>CC FAMILY</b>		
CCL1	I-309	TCA-3, P500
CCL2	MCP-1/MCAF	JE/MCAF/MCP-1
CCL3	MIP-1 $\alpha$ /LD78 $\alpha$	MIP-1 $\alpha$
CCL4	MIP-1 $\beta$	MIP-1 $\beta$
CCL5	RANTES	RANTES
CCL6	?	C10, MRP-1
CCL7	MCP-3	MARC/MCP-3
CCL8	MCP-2	MCP-2/HC14
CCL9/10	?	MRP-2/CCF18
CCL11	Eotaxin-1	Eotaxin-1
CCL12	?	MCP-5
CCL13	MCP-4	?
CCL14	HCC-1	?
CCL15	HCC-2/Lkn-1/MIP-1	?
CCL16	HCC-4/LEC	LEC/HCC-4/LMC
CCL17	TARC	TARC
CCL18	DC-CK1/PARC/AMAC-1	Madh3
CCL19	MIP-3 $\beta$ /ELC/exodus-3	MIP-3 $\beta$ /ELC/exodus-3
CCL20	MIP-3 $\alpha$ /LARC/exodus-1	MIP-3 $\alpha$ /LARC/exodus-1
CCL21	6Ckine/SLC/exodus-2	6Ckine/SLC/exodus-2/ TCA-4
CCL22	MDC/STCP-1	ABCD-1
CCL23	MPIF-1	?
CCL24	MPIF-2/Eotaxin-2	Eotaxin-2
CCL25	TECK	TECK
CCL26	Eotaxin-3	?
CCL27	CTACK/ILC	ALP/CTACK/ILC/ESkine
CCL28	MEC	MEC
<b>C FAMILY</b>		
XCL1	Lymphotactin/SCM-1 $\alpha$ / ATAC	Lymphotactin
XCL2	SCM-1 $\beta$	?
<b>CX3C FAMILY</b>		
CX3CL1	Fractalkine	Neurotactin

\*A question mark indicates that the mouse and human homologs are ambiguous.

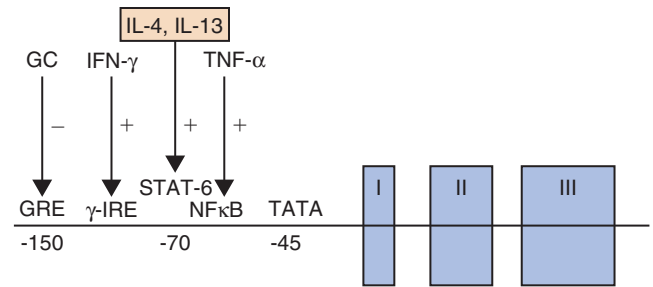

**Figure 5-9** Regulatory elements in chemokine promoter. Depicted are the positions of the transcription factor motifs and the regulatory cytokines of the eotaxin-1 promoter. The three exons of the gene are depicted with rectangles. Positive signals are indicated with (+), whereas inhibitory signals are indicated with (-). Notably, IL-4/IL-13 via STAT-6 induces transcription; IFN- $\gamma$  induces transcription through an IFN response element ( $\gamma$ -IRE); and TNF- $\alpha$  induces transcription through NF $\kappa$ B. Glucocorticoids (GC) inhibit transcription via the glucocorticoid response element (GRE).

## BOX 5-7 KEY CONCEPTS

## Chemokines

- Chemokines are chemoattractive cytokines.
- Chemokines are functionally divided into molecules that are constitutively expressed and those that are inducible.
- Chemokines are divided into several families depending on the spacing of the first two cysteines (e.g. CC and CXC families).
- Chemokines bind to seven-transmembrane, G protein-linked receptors.
- Chemokine receptors are genetically polymorphic.
- Chemokine receptors often bind to more than one chemokine ligand (i.e. they are promiscuous).

## CELLULAR RECEPTOR EXPRESSION

Chemokine receptors are constitutively expressed on some cells, whereas they are inducible on others. For example, CCR1 and CCR2 are constitutively expressed on monocytes but are expressed on lymphocytes only after IL-2 stimulation.<sup>171,172</sup> Activated lymphocytes are then responsive to multiple CC chemokines that use these receptors, including the MCPs. In addition, some constitutive receptors can be down-modulated by biologic response modifiers. For example, IL-10 was shown to modify the activity of CCR1, CCR2 and CCR5 on dendritic cells and monocytes.<sup>173</sup> Normally, dendritic cells mature in response to inflammatory stimuli and shift from expressing CCR1, CCR2, CCR5 and CCR6 to expressing CCR7. However, IL-10 blocks the chemokine receptor switch. Importantly, although CCR1, CCR2 and CCR5 remain detectable on the cell surface and bind appropriate ligands, they do not signal in calcium mobilization or chemotaxis assays. Thus, IL-10 converts chemokine receptors to functional decoy receptors, thereby serving a down-regulatory function (Box 5-7).

## Chemokine Regulation of Leukocyte Effector Function

## CHEMOATTRACTION

Structural motifs in the primary amino acid sequence of chemokines have an important impact on their chemoattractive



ability. For example, CXC chemokines are mainly chemoattractants for neutrophils and lymphocytes. Furthermore, ELR (Glu-Leu-Arg)-containing CXC chemokines (e.g. IL-8) are mainly chemoattractive on neutrophils, whereas non-ELR CXC chemokines (e.g. IP-10) chemoattract selected populations of lymphocytes (Figure 5-7). In contrast to cellular specificity of CXC chemokines, CC chemokines are active on a variety of leukocytes, including dendritic cells, monocytes, basophils, lymphocytes and eosinophils. For example, as their names imply, all MCPs have strong chemoattractive activity for monocytes. However, they display partially overlapping chemoattractant activity on basophils and eosinophils. In particular, MCP-2, MCP-3 and MCP-4 have basophil and eosinophil chemoattractive activity, but MCP-1 is only active on basophils. In contrast to the MCPs, the members of the eotaxin subfamily of chemokines (i.e. eotaxin-1, -2 and -3) have limited activity on macrophages but are potent eosinophil and basophil chemoattractants.<sup>174,175</sup> Chemokines also work in concert with other cytokines to promote leukocyte trafficking. IL-5 collaborates with eotaxin in promoting tissue eosinophilia by (1) increasing the pool of circulating eosinophils (by stimulating eosinophilopoiesis and bone marrow release) and (2) priming eosinophils to have enhanced responsiveness to eotaxin. The ability of two cytokines (IL-5 and eotaxin) that are relatively eosinophil selective to cooperate in promoting tissue eosinophilia offers a molecular explanation for the occurrence of selective tissue eosinophilia in human allergic diseases (Box 5-8).

## CELLULAR ACTIVATION

In addition to promoting leukocyte accumulation, chemokines are potent cell activators. After binding to the appropriate GPCR, chemokines elicit transient intracellular calcium flux, localized actin reorganization, oxidative burst with release of superoxide free radicals, the exocytosis of secondary granule constituents and increased avidity of integrins for their adhesion molecules. For example, in basophils, chemokine-induced cellular activation results in degranulation with the release of histamine and the de novo generation of LTC<sub>4</sub>.<sup>158,176,177</sup> Basophil activation by chemokines requires cellular priming with IL-3, IL-5 or GM-CSF for the maximal effect of each chemokine, highlighting the capacity for cooperation between cytokines and chemokines.

## HEMATOPOIESIS

In addition to being involved in leukocyte accumulation, chemokines also have a role in regulating hematopoiesis. These

functions include (1) chemotaxis of hematopoietic progenitor cells (HPC), (2) suppressing or enhancing HPC proliferation and differentiation and (3) mobilizing HPCs to the peripheral blood.<sup>178</sup> For example, stromal cell-derived factor (SDF)-1, a CXC chemokine, is critical for B cell lymphopoiesis and bone marrow myelopoiesis as demonstrated by gene targeting.<sup>179</sup> Furthermore, eotaxin has been shown to directly stimulate the release of eosinophilic progenitor cells and mature eosinophils from the bone marrow.<sup>180</sup> Eotaxin synergizes with SCF in stimulating yolk sac development into mast cells in vitro<sup>181</sup> and has been shown to function as a GM-CSF after allergic challenge in the lungs.<sup>182</sup>

## MODULATION OF T CELL IMMUNE RESPONSES

T lymphocytes have been shown to express receptors for most chemokines, thus making them potentially responsive to a large number of different chemokines. Characterization of chemokine receptor expression has shown that T lymphocytes display a dynamic expression pattern of chemokine receptors and that it is the differential expression of receptors during T lymphocyte maturation and differentiation that is thought to allow for individual chemokine-specific functionality on T lymphocytes.<sup>183</sup> As with dendritic cells, CCR7 also plays an important role in trafficking of naïve T cells into lymph nodes.<sup>184</sup> Upon activation, T cells may express an array of chemokine receptors. Thus, they become sensitive to inflammatory chemokines, including MIP-1 $\alpha$ , MIP-1 $\beta$ , MCP-3 and RANTES, which are thought to mediate T cell trafficking to sites of inflammation.<sup>185</sup>

Chemokines have an important role in the induction of inflammatory responses and are central in selecting the type of T helper response. During bacterial or viral infections, IP-10, MIG, IL-8 and I-TAC production correlates with the presence of CD4<sup>+</sup> Th1-type T cells. In contrast, during allergic inflammatory responses, eotaxin, RANTES, MCP-2, MCP-3 and MCP-4 are induced, and the majority of the CD4<sup>+</sup> T lymphocytes are of the Th2-type phenotype. The characterization of chemokine receptor expression on T lymphocytes suggests that these findings may be explained by CXCR3 and CCR5 being predominantly expressed on Th1-type T cells, whereas CCR3, CCR4 and CCR8 have been associated with Th2-type T cells and CCR6 on Th17 cells (Figure 5-5). In addition, Th1 and Th2 cells secrete distinct chemokines<sup>186</sup> (Figure 5-5). In mice, Th1 cells preferentially secrete RANTES and lymphotactin, whereas Th2 cells secrete MDC and TCA3. Interestingly, supernatants from Th2 cells preferentially attract Th2 cells. Alternatively, chemokines may directly influence the differentiation of naïve T cells to the Th1 or Th2 phenotype. MIP-1 $\alpha$  and MCP-1 have been described as capable of inducing the differentiation of Th1 and Th2 cells,<sup>187</sup> and MCP-1-deficient mice have defective Th2 responses.<sup>188</sup> Consistent with this possibility, BCL-6-deficient animals express high levels of chemokines, including MCP-1, and have systemic Th2-type inflammation.<sup>189</sup>

The interaction of tissue-specific dendritic cells with T cells triggers expression of tissue-specific homing molecules on T cells. For example, intestinal dendritic cells induce direct T cell expression of the intestinal homing molecules  $\alpha_4\beta_7$  and CCR9,<sup>190</sup> which recognize intestinal vascular mucosal addressin cell adhesion molecule 1 (MAdCAM-1) and intestinal epithelial CCL25.<sup>190</sup>

### BOX 5-8 KEY CONCEPTS

#### Chemokines in Allergic Responses

- Chemokines regulate leukocyte recruitment.
- Chemokines are potent cellular activating factors.
- Chemokines are potent histamine-releasing factors.
- Th2 cytokines (e.g. IL-4 and IL-13) are potent inducers of allergy-associated chemokines (e.g. eotaxin).
- In allergic tissue, chemokines are frequently produced by epithelial cells.

## Conclusion

Allergic disorders involve the complex interplay of a large number of leukocytes (especially mast cells, eosinophils, neutrophils, lymphocytes, basophils, dendritic cells, innate lymphocytes and lymphoid cells) and structural tissue cells (especially epithelial cells, smooth muscle cells and fibroblasts). A combination of murine and human studies has been used to define the specific mechanisms involved in leukocyte activation, migration and effector function. In particular, cellular adhesion proteins, integrins and chemokines have emerged as critical molecules involved in leukocyte accumulation and activation. Also, combinations of innate activation pathways (involving mast

cells, dendritic cells, eosinophils and innate lymphocytes and lymphoid cells) that induce proinflammatory pathways and adaptive immune pathways have been elucidated. Although we are in the early phases of analysis of disease pathogenesis, we have already identified critical pathways that are currently being therapeutically targeted in patients. It is the authors' hope that this chapter has provided the appropriate framework for the reader to understand (and contribute to) the next generation of clinical intervention strategies for the treatment of allergic disorders.

The complete reference list can be found on the companion Expert Consult website at <http://www.expertconsult.inkling.com>.

## KEY REFERENCES

19. Nussbaum JC, Van Dyken SJ, Moltke von J, Cheng LE, Mohapatra A, Molofsky AB, et al. Type 2 innate lymphoid cells control eosinophil homeostasis. *Nature* 2013;502:245–8.
60. Fahy JV, Fleming HE, Wong HH, Liu JT, Su JQ, Reimann J, et al. The effect of an anti-IgE monoclonal antibody on the early- and late-phase responses to allergen inhalation in asthmatic subjects. *Am J Respir Crit Care Med* 1997;155:1828–34.
78. Tsujimura Y, Obata K, Mukai K, Shindou H, Yoshida M, Nishikado H, et al. Basophils play a pivotal role in immunoglobulin-G-mediated but not immunoglobulin-E-mediated systemic anaphylaxis. *Immunity* 2008;28:581–9.
83. Aderem A, Ulevitch RJ. Toll-like receptors in the induction of the innate immune response. *Nature* 2000;406:782–7.
124. Robinson DS, Hamid Q, Ying S, Tsicopoulos A, Barkans J, Bentley AM, et al. Predominant TH2-like bronchoalveolar T-lymphocyte population in atopic asthma. *N Engl J Med* 1992;326:298–304.
132. Brusselle GG, Kips JC, Tavernier JH, van der Heyden JG, Cuvelier CA, Pauwels RA, et al. Attenuation of allergic airway inflammation in IL-4 deficient mice. *Clin Exp Allergy* 1994;24:73–80.
136. Wills-Karp M, Luyimbazi J, Xu X, Schofield B, Neben TY, Karp CL, et al. Interleukin-13: central mediator of allergic asthma. *Science* 1998;282:2258–61.
152. Fallon PG. Identification of an interleukin (IL)-25-dependent cell population that provides IL-4, IL-5, and IL-13 at the onset of helminth expulsion. *J Exp Med* 2006;203:1105–16.
159. Garcia-Zepeda EA, Rothenberg ME, Ownbey RT, Celestin J, Leder P, Luster AD. Human eotaxin is a specific chemoattractant for eosinophil cells and provides a new mechanism to explain tissue eosinophilia. *Nat Med* 1996;2:449–56.
173. D'Amico G, Frascaroli G, Bianchi G, Transidico P, Doni A, Vecchi A, et al. Uncoupling of inflammatory chemokine receptors by IL-10: generation of functional decoys. *Nat Immunol* 2000;1:387–91.

## REFERENCES

- Wardlaw AJ, Dunnette S, Gleich GJ, Collins JV, Kay AB. Eosinophils and mast cells in bronchoalveolar lavage in subjects with mild asthma. Relationship to bronchial hyperreactivity. *Am Rev Respir Dis* 1988;137:62–9.
- Broide DH, Firestein GS. Endobronchial allergen challenge in asthma. Demonstration of cellular source of granulocyte macrophage colony-stimulating factor by in situ hybridization. *J Clin Invest* 1991;88:1048–53.
- Lam S, LeRiche J, Phillips D, Chan-Yeung M. Cellular and protein changes in bronchial lavage fluid after late asthmatic reaction in patients with red cedar asthma. *J Allergy Clin Immunol* 1987;80:44–50.
- Beasley R, Roche WR, Roberts JA, Holgate ST. Cellular events in the bronchi in mild asthma and after bronchial provocation. *Am Rev Respir Dis* 1989;139:806–17.
- De Monchy JG, Kauffman HF, Venge P, Koeter GH, Jansen HM, Sleuter HJ, et al. Bronchoalveolar eosinophilia during allergen-induced late asthmatic reactions. *Am Rev Respir Dis* 1985;131:373–6.
- Gleich GJ, Flavahan NA, Fujisawa T, Vanhoutte PM. The eosinophil as a mediator of damage to respiratory epithelium: a model for bronchial hyperreactivity. *J Allergy Clin Immunol* 1988;81:776–81.
- Walker C, Kaegi MK, Braun P, Blaser K. Activated T cells and eosinophilia in bronchoalveolar lavages from subjects with asthma correlated with disease severity. *J Allergy Clin Immunol* 1991;88:935–42.
- Fukuda T, Dunnette SL, Reed CE, Ackerman SJ, Peters MS, Gleich GJ. Increased numbers of hypodense eosinophils in the blood of patients with bronchial asthma. *Am Rev Respir Dis* 1985;132:981–5.
- Wills-Karp M. Immunologic basis of antigen-induced airway hyperresponsiveness. *Annu Rev Immunol* 1999;17:255–81.
- Bochner BS, Udem BJ, Lichtenstein LM. Immunological aspects of allergic asthma. *Annu Rev Immunol* 1994;12:295–335.
- Barnes PJ. New directions in allergic diseases: mechanism-based anti-inflammatory therapies. *J Allergy Clin Immunol* 2000;106:5–16.
- Weller PF. The immunobiology of eosinophils. *N Engl J Med* 1991;324:1110–18.
- Gouon-Evans V, Rothenberg ME, Pollard JW. Postnatal mammary gland development requires macrophages and eosinophils. *Development* 2000;127:2269–82.
- Jung Y, Rothenberg ME. Roles and regulation of gastrointestinal eosinophils in immunity and disease. *J Immunol* 2014;193:999–1005.
- Rothenberg ME, Hogan SP. The eosinophil. *Annu Rev Immunol* 2006;24:147–74.
- Rosenberg HF, Dyer KD, Foster PS. Eosinophils: changing perspectives in health and disease. *Nat Rev Immunol* 2012;13:9–22.
- Wu D, Molofsky AB, Liang H-E, Ricardo-Gonzalez RR, Jouihan HA, Bando JK, et al. Eosinophils sustain adipose alternatively activated macrophages associated with glucose homeostasis. *Science* 2011;332:243–7.
- Hogan SP, Brandt EB, Mishra A, Foster PS, Rothenberg ME. The chemokine eotaxin is a central mediator of experimental eosinophilic gastrointestinal allergy. *J Allergy Clin Immunol* 1999;105:s379.
- Nussbaum JC, Van Dyken SJ, Moltke von J, Cheng LE, Mohapatra A, Molofsky AB, et al. Type 2 innate lymphoid cells control eosinophil homeostasis. *Nature* 2013;502:245–8.
- Rothenberg ME. Eosinophilia. *N Engl J Med* 1998;338:1592–600.
- Yang D, Chen Q, Su SB, Zhang P, Kurosaka K, Caspi RR, et al. Eosinophil-derived neurotoxin acts as an alarmin to activate the TLR2-MyD88 signal pathway in dendritic cells and enhances Th2 immune responses. *J Exp Med* 2008;205:79–90.
- Fulkerson PC, Rothenberg ME. Targeting eosinophils in allergy, inflammation and beyond. *Nat Rev Drug Discov* 2013;12:117–29.
- Lewis RA, Austen KE, Soberman RJ. Leukotrienes and other products of the 5-lipoxygenase pathway. Biochemistry and relation to pathobiology in human diseases. *N Engl J Med* 1990;323:645–55.
- Kita H. The eosinophil: a cytokine-producing cell? *J Allergy Clin Immunol* 1996;97:889–92.
- Ohkawara Y, Lim KG, Xing Z, Glibetic M, Nakano K, Dolovich J, et al. CD40 expression by human peripheral blood eosinophils. *J Clin Invest* 1996;97:1761–6.
- Woerly G, Roger N, Loiseau S, Dombrowicz D, Capron A, Capron M. Expression of CD28 and CD86 by human eosinophils and role in the secretion of type 1 cytokines (interleukin 2 and interferon gamma): inhibition by immunoglobulin a complexes. *J Exp Med* 1999;190:487–95.
- Lucey DR, Nicholson-Weller A, Weller PF. Mature human eosinophils have the capacity to express HLA-DR. *Proc Natl Acad Sci U S A* 1989;86:1348–51.
- Lacy P, Levi-Schaffer F, Mahmudi-Azer S, Bablitz B, Hagen SC, Velazquez J, et al. Intracellular localization of interleukin-6 in eosinophils from atopic asthmatics and effects of interferon gamma. *Blood* 1998;91:2508–16.
- Shi HZ, Humbles A, Gerard C, Jin Z, Weller PF. Lymph node trafficking and antigen presentation by endobronchial eosinophils. *J Clin Invest* 2000;105:945–53.
- Yousefi S, Gold JA, Andina N, Lee JJ, Kelly AM, Kozlowski E, et al. Catapult-like release of mitochondrial DNA by eosinophils contributes to antibacterial defense. *Nat Med* 2008;14:949–53.
- Justice JB, Borchers MT, Crosby JR, Hines EM, Shen HH, Ochku SI, et al. Ablation of eosinophils leads to a reduction of allergen-induced pulmonary pathology. *Am J Physiol Lung Cell Mol Physiol* 2003;284:169–78.
- Cowburn AS, Sladek K, Soja J, Adamek L, Nizankowska E, Szczeklik A, et al. Overexpression of leukotriene C4 synthase in bronchial biopsies from patients with aspirin-intolerant asthma. *J Clin Invest* 1998;101:834–46.
- Jacoby DB, Costello RM, Fryer AD. Eosinophil recruitment to the airway nerves. *J Allergy Clin Immunol* 2001;107:211–18.
- Jacobsen EA, Ochku SI, Pero RS, Taranova AG, Protheroe CA, Colbert DC, et al. Allergic pulmonary inflammation in mice is dependent on eosinophil-induced recruitment of effector T cells. *J Exp Med* 2008;205:699–710.
- Fulkerson PC, Fischetti CA, McBride ML, Hassman LM, Hogan SP, Rothenberg ME. A central regulatory role for eosinophils and the eotaxin/CCR3 axis in chronic experimental allergic airway inflammation. *Proc Natl Acad Sci U S A* 2006;103:16418–23.
- Moore WC, Meyers DA, Wenzel SE, Teague WG, Li H, Li X, et al. Identification of asthma phenotypes using cluster analysis in the Severe Asthma Research Program. *Am J Respir Crit Care Med* 2010;181:315–23.
- Akuthota P, Weller PF. Eosinophils and disease pathogenesis. *Semin Hematol* 2012;49:113–19.
- Valent P, Gleich GJ, Reiter A, Roufosse F, Weller PF, Hellmann A, et al. Pathogenesis and classification of eosinophil disorders: a review of recent developments in the field. *Expert Rev Hematol* 2012;5:157–76.
- Gevaert P, Van Bruaene N, Cattaert T. Mepolizumab, a humanized anti-IL-5 mAb, as a treatment option for severe nasal polyposis. *J Allergy Clin Immunol* 2011;128:989–95.
- Davis MDP, Plager DA, George TJ, Weiss EA, Gleich GJ, Leiferman KM. Interactions of eosinophil granule proteins with skin: limits of detection, persistence, and vasopermeabilization. *J Allergy Clin Immunol* 2003;112:988–94.
- Rothenberg ME. Eosinophilic gastrointestinal disorders (EGID). *J Allergy Clin Immunol* 2004;113:11–28.
- Bascom R, Pipkorn U, Proud D, Dunnette S. Major basic protein and eosinophil-derived neurotoxin concentrations in nasal-lavage fluid after antigen challenge: effect of systemic corticosteroids and relationship to eosinophil influx. *J Allergy Clin Immunol* 1989;84:338–46.
- Echtenacher B, Männel DN, Hültner L. Critical protective role of mast cells in a model of acute septic peritonitis. *Nature* 1996;381:75–7.
- Akahoshi M, Song CH, Piliipovsky AM, Metz M, Guzzetta A, Abrink M, et al. Mast cell chymase reduces the toxicity of Gila monster venom, scorpion venom, and vasoactive intestinal polypeptide in mice. *J Clin Invest* 2011;121:4180–91.
- Weller K, Foitzik K, Paus R, Syska W, Maurer M. Mast cells are required for normal healing of skin wounds in mice. *FASEB J* 2006;20:2366–8.
- Kitamura Y, Go S, Hatanaka K. Decrease of mast cells in W/W<sup>v</sup> mice and their increase by bone marrow transplantation. *Blood* 1978;52:447–52.
- Geissler EN, Ryan MA, Housman DE. The dominant-white spotting (W) locus of the mouse encodes the c-kit proto-oncogene. *Cell* 1988;55:185–92.
- Flanagan JG, Leder P. The kit ligand: a cell surface molecule altered in steel mutant fibroblasts. *Cell* 1990;63:185–94.
- Hsieh FH, Lam BK, Penrose JF, Austen KE, Boyce JA. T helper cell type 2 cytokines coordinately regulate immunoglobulin E-dependent cysteinyl leukotriene production by human cord blood-derived mast cells: profound induction of leukotriene C(4) synthase expression by interleukin 4. *J Exp Med* 2001;193:123–33.
- Oh S-W, Pae CI, Lee D-K, Jones F, Chiang GKS, Kim H-O, et al. Tryptase inhibition blocks airway inflammation in a mouse asthma model. *J Immunol* 2002;168:1992–2000.
- Bradding P, Roberts JA, Britten KM, Montefort S, Djukanovic R, Mueller R, et al. Interleukin-4, -5, and -6 and tumor necrosis factor-alpha in normal and asthmatic airways: evidence for the human mast cell as a source

- of these cytokines. *Am J Respir Cell Mol Biol* 1994;10:471–80.
52. Williams CM, Galli SJ. The diverse potential effector and immunoregulatory roles of mast cells in allergic disease. *J Allergy Clin Immunol* 2000;105:847–59.
  53. Leonardi A. The central role of conjunctival mast cells in the pathogenesis of ocular allergy. *Curr Allergy Asthma Rep* 2002;2:325–31.
  54. Saini SS, Paterniti M, Vasagar K, Gibbons SP, Sterba PM, Vonakis BM. Cultured peripheral blood mast cells from chronic idiopathic urticaria patients spontaneously degranulate upon IgE sensitization: relationship to expression of Syk and SHIP-2. *Clin Immunol* 2009;132:342–8.
  55. Huels C, Germann T, Goedert S, Hoehn P, Koelsch S, Hültner L, et al. Co-activation of naive CD4+ T cells and bone marrow-derived mast cells results in the development of Th2 cells. *Int Immunol* 1995;7:525–32.
  56. Theiner G, Gessner A, Lutz MB. The mast cell mediator PGD2 suppresses IL-12 release by dendritic cells leading to Th2 polarized immune responses in vivo. *Immunobiology* 2006;211:463–72.
  57. Mazzoni A, Siraganian RP, Leifer CA, Segal DM. Dendritic cell modulation by mast cells controls the Th1/Th2 balance in responding T cells. *J Immunol* 2006;177:3577–81.
  58. Skokos D, Botros HG, Demeure C, Morin J, Peronet R, Birkenmeier G, et al. Mast cell-derived exosomes induce phenotypic and functional maturation of dendritic cells and elicit specific immune responses in vivo. *J Immunol* 2003;170:3037–45.
  59. Suto H, Nakae S, Kakurai M, Sedgwick JD, Tsai M, Galli SJ. Mast cell-associated TNF promotes dendritic cell migration. *J Immunol* 2006;176:4102–12.
  60. Fahy JV, Fleming HE, Wong HH, Liu JT, Su JQ, Reimann J, et al. The effect of an anti-IgE monoclonal antibody on the early- and late-phase responses to allergen inhalation in asthmatic subjects. *Am J Respir Crit Care Med* 1997;155:1828–34.
  61. Horsmanheimo L, Harvima IT, Järvikallio A, Harvima RJ, Naukkarinen A, Horsmanheimo M. Mast cells are one major source of interleukin-4 in atopic dermatitis. *Br J Dermatol* 1994;131:348–53.
  62. Abonia JP, Blanchard C, Butz BB, Rainey HF, Collins MH, Stringer K, et al. Involvement of mast cells in eosinophilic esophagitis. *J Allergy Clin Immunol* 2010;126:140–9.
  63. Boyce JA, Friend D, Matsumoto R, Austen KF, Owen WF. Differentiation in vitro of hybrid eosinophil/basophil granulocytes: autocrine function of an eosinophil developmental intermediate. *J Exp Med* 1995;182:49–57.
  64. Schwartz LB. Mast cells and basophils. *Clin Allergy Immunol* 2002;16:3–42.
  65. Miura K, Saini SS, Gauvreau G, MacGlashan DW. Differences in functional consequences and signal transduction induced by IL-3, IL-5, and nerve growth factor in human basophils. *J Immunol* 2001;167:2282–91.
  66. Devouassoux G, Foster B, Scott LM, Metcalfe DD, Prussin C. Frequency and characterization of antigen-specific IL-4- and IL-13- producing basophils and T cells in peripheral blood of healthy and asthmatic subjects. *J Allergy Clin Immunol* 1999;104:811–19.
  67. Yoshimoto T, Yasuda K, Tanaka H, Nakahira M, Imai Y, Fujimori Y, et al. Basophils contribute to TH2-IgE responses in vivo via IL-4 production and presentation of peptide–MHC class II complexes to CD4+ T cells. *Nat Immunol* 2009;10:706–12.
  68. Perrigoue JG, Saenz SA, Siracusa MC, Allenspach EJ, Taylor BC, Giacomini PR, et al. MHC class II–dependent basophil–CD4+ T cell interactions promote TH2 cytokine-dependent immunity. *Nat Immunol* 2009;10:697–705.
  69. Sokol CL, Chu N-Q, Yu S, Nish SA, Laufer TM, Medzhitov R. Basophils function as antigen-presenting cells for an allergen-induced T helper type 2 response. *Nat Immunol* 2009;10:713–20.
  70. Voehringer D. The role of basophils in helminth infection. *Trends Parasitol* 2009;25:551–6.
  71. Wada T, Ishiwata K, Koseki H, Ishikura T, Ugajin T, Ohnuma N, et al. Selective ablation of basophils in mice reveals their nonredundant role in acquired immunity against ticks. *J Clin Invest* 2010;120:2867–75.
  72. Noti M, Wojno EDT, Kim BS, Siracusa MC, Giacomini PR, Nair MG, et al. Thymic stromal lymphopoietin–elicited basophil responses promote eosinophilic esophagitis. *Nat Med* 2013;19:1005–13.
  73. Naclerio RM, Proud D, Togias AG, Adkinson NF, Meyers DA, Kagey-Sobotka A, et al. Inflammatory mediators in late antigen-induced rhinitis. *N Engl J Med* 1985;313:65–70.
  74. Guo CB, Liu MC, Galli SJ, Bochner BS, Kagey-Sobotka A, Lichtenstein LM. Identification of IgE-bearing cells in the late-phase response to antigen in the lung as basophils. *Am J Respir Cell Mol Biol* 1994;10:384–90.
  75. Richerson HB, Dvorak HF, Leskowitz S. Cutaneous basophilic hypersensitivity: a new interpretation of the Jones-Mote reaction. *J Immunol* 1969;103:1431–4.
  76. Uguccioni M, Mackay CR, Ochensberger B, Loetscher P, Rhis S, LaRosa GJ, et al. High expression of the chemokine receptor CCR3 in human blood basophils. Role in activation by eotaxin, MCP-4, and other chemokines. *J Clin Invest* 1997;100:1137–43.
  77. Khodoun M, Strait R, Orekov T, Hogan S, Karasuyama H, Herbert DR, et al. Peanuts can contribute to anaphylactic shock by activating complement. *J Allergy Clin Immunol* 2009;123:342–51.
  78. Tsubimura Y, Obata K, Mukai K, Shindou H, Yoshida M, Nishikado H, et al. Basophils play a pivotal role in immunoglobulin-G-mediated but not immunoglobulin-E-mediated systemic anaphylaxis. *Immunity* 2008;28:581–9.
  79. Thomas ED, Ramberg RE, Sale GE, Sparkes RS, Golde DW. Direct evidence for a bone marrow origin of the alveolar macrophage in man. *Science* 1976;192:1016–18.
  80. Hume DA, Robinson AP, MacPherson GG, Gordon S. The mononuclear phagocyte system of the mouse defined by immunohistochemical localization of antigen F4/80. Relationship between macrophages, Langerhans cells, reticular cells, and dendritic cells in lymphoid and hematopoietic organs. *J Exp Med* 1983;158:1522–36.
  81. Begg SK, Radley JM, Pollard JW, Chisholm OT, Stanley ER, Bertoncello I. Delayed hematopoietic development in osteopetrotic (op/op) mice. *J Exp Med* 1993;177:237–42.
  82. Trapnell BC, Whitsett JA. Gm-CSF regulates pulmonary surfactant homeostasis and alveolar macrophage-mediated innate host defense. *Annu Rev Physiol* 2002;64:775–802.
  83. Aderem A, Ulevitch RJ. Toll-like receptors in the induction of the innate immune response. *Nature* 2000;406:782–7.
  84. Rivier A, Pene J, Rabesandratana H, Chanez P, Bousquet J, Campbell AM. Blood monocytes of untreated asthmatics exhibit some features of tissue macrophages. *Clin Exp Immunol* 1995;100:314–18.
  85. Poston RN, Chanez P, Lacoste JY, Litchfield T, Lee TH, Bousquet J. Immunohistochemical characterization of the cellular infiltration in asthmatic bronchi. *Am Rev Respir Dis* 1992;145:918–21.
  86. Sousa AR, Lane SJ, Nakhosteen JA, Yoshimura T, Lee TH, Poston RN. Increased expression of the monocyte chemoattractant protein-1 in bronchial tissue from asthmatic subjects. *Am J Respir Cell Mol Biol* 1994;10:142–7.
  87. Gea-Sorli S, Guillamat R, Serrano-Mollar A, Closa D. Activation of lung macrophage subpopulations in experimental acute pancreatitis. *J Pathol* 2011;223:417–24.
  88. Thepen T, McMenamin C, Oliver J, Kraal G, Holt PG. Regulation of immune response to inhaled antigen by alveolar macrophages: differential effects of in vivo alveolar macrophage elimination on the induction of tolerance vs. immunity. *Eur J Immunol* 1991;21:2845–50.
  89. Bedoret D, Wallemacq H, Marichal T, Desmet C, Quesada Calvo F, Henry E, et al. Lung interstitial macrophages alter dendritic cell functions to prevent airway allergy in mice. *J Clin Invest* 2009;119:3723–38.
  90. Mills CD. Macrophage arginine metabolism to ornithine/urea or nitric oxide/citrulline: a life or death issue. *Crit Rev Immunol* 2001;21:399–425.
  91. Goleva E, Hauk PJ, Hall CF, Liu AH, Riches DWH, Martin RJ, et al. Corticosteroid-resistant asthma is associated with classical antimicrobial activation of airway macrophages. *J Allergy Clin Immunol* 2008;122:550–9, e3.
  92. Kim EY, Battaile JT, Patel AC, You Y, Agapov E, Grayson MH, et al. Persistent activation of an innate immune response translates respiratory viral infection into chronic lung disease. *Nat Med* 2008;14:633–40.
  93. Melgert BN, Hacken ten NH, Rutgers B, Timens W, Postma DS, Hylkema MN. More alternative activation of macrophages in lungs of asthmatic patients. *J Allergy Clin Immunol* 2011;127:831–3.
  94. Cartwright GE, Athens JW, Wintrobe MM. The kinetics of granulopoiesis in normal man. *Blood* 1964;24:780–803.
  95. Reeves EP, Lu H, Jacobs HL, Messina CGM, Bolsover S, Gabella G, et al. Killing activity of neutrophils is mediated through activation of proteases by K+ flux. *Nature* 2002;416:291–7.
  96. Kelly C, Ward C, Stenton CS, Bird G, Hendrick DJ, Walters EH. Number and activity of inflammatory cells in bronchoalveolar lavage fluid in asthma and their relation to airway responsiveness. *Thorax* 1988;43:684–92.
  97. Sur S, Crotty TB, Kephart GM, Hyma BA, Colby TV, Reed CE, et al. Sudden-onset fatal asthma. A distinct entity with few eosinophils and relatively more neutrophils in the airway submucosa? *Am Rev Respir Dis* 1993;148:713–19.



98. Simpson JL, Scott R, Boyle MJ, Gibson PG. Inflammatory subtypes in asthma: assessment and identification using induced sputum. *Respirology* 2006;11:54–61.
99. Gibson PG, Wark PAB, Simpson JL, Meldrum C, Meldrum S, Salto N, et al. Induced sputum IL-8 gene expression, neutrophil influx and MMP-9 in allergic bronchopulmonary aspergillosis. *Eur Respir J* 2003;21:582–8.
100. Mahler DA, Huang S, Tabrizi M, Bell GM. Efficacy and safety of a monoclonal antibody recognizing interleukin-8 in COPD: a pilot study. *Chest* 2004;126:926–34.
101. Lazaar AL, Sweeney LE, MacDonald AJ, Alexis NE, Chen C, Tal-Singer R. SB-656933, a novel CXCR2 selective antagonist, inhibits ex vivo neutrophil activation and ozone-induced airway inflammation in humans. *Br J Clin Pharmacol* 2011;72:282–93.
102. Randolph GJ. Dendritic cell migration to lymph nodes: cytokines, chemokines, and lipid mediators. *Semin Immunol* 2001;13:267–74.
103. Lambrecht BN. The dendritic cell in allergic airway diseases: a new player to the game. *Clin Exp Allergy* 2001;31:206–18.
104. Keller R. Dendritic cells: their significance in health and disease. *Immunol Lett* 2001;78:113–22.
105. Collin M, McGovern N, Haniffa M. Human dendritic cell subsets. *Immunology* 2013;140:22–30.
106. Tanaka H, Demeure CE, Rubio M, Delespesse G, Sarfati M. Human monocyte-derived dendritic cells induce naive T cell differentiation into T helper cell type 2 (Th2) or Th1/Th2 effectors. Role of stimulator/responder ratio. *J Exp Med* 2000;192:405–12.
107. Hutloff A, Dittrich AM, Beier KC, Eljaschewitsch B, Kraft R, Anagnostopoulos I, et al. ICOS is an inducible T-cell co-stimulator structurally and functionally related to CD28. *Nature* 1999;397:263–6.
108. Kool M, Willart MAM, van Nimwegen M, Bergen I, Pouliot P, Virchow JC, et al. An unexpected role for uric acid as an inducer of T helper 2 cell immunity to inhaled antigens and inflammatory mediator of allergic asthma. *Immunity* 2011;34:527–40.
109. Hammad H, Chieppa M, Perros F, Willart MA, Germain RN, Lambrecht BN. House dust mite allergen induces asthma via Toll-like receptor 4 triggering of airway structural cells. *Nat Med* 2009;15:410–16.
110. Eiwegger T, Akdis CA. IL-33 links tissue cells, dendritic cells and Th2 cell development in a mouse model of asthma. *Eur J Immunol* 2011;41:1535–8.
111. Traidl-Hoffmann C, Mariani V, Hochrein H, Karg K, Wagner H, Ring J, et al. Pollen-associated phytoosteranes inhibit dendritic cell interleukin-12 production and augment T helper type 2 cell polarization. *J Exp Med* 2005;201:627–36.
112. Smole U, Balazs N, Hoffmann-Sommergruber K, Radauer C, Hafner C, Wallner M, et al. Differential T-cell responses and allergen uptake after exposure of dendritic cells to the birch pollen allergens Bet v 1.0101, Bet v 1.0401 and Bet v 1.1001. *Immunobiology* 2010;215:903–9.
113. Hammad H, Lambrecht BN, Pochard P, Gosset P, Marquillies P, Tonnel A-B, et al. Monocyte-derived dendritic cells induce a house dust mite-specific Th2 allergic inflammation in the lung of humanized SCID mice: involvement of CCR7. *J Immunol* 2002;169:1524–34.
114. Lambrecht BN, Salomon B, Klatzmann D, Pauwels RA. Dendritic cells are required for the development of chronic eosinophilic airway inflammation in response to inhaled antigen in sensitized mice. *J Immunol* 1998;160:4090–7.
115. Lambrecht BN, De Veerman M, Coyle AJ, Gutierrez-Ramos JC, Thielemans K, Pauwels RA. Myeloid dendritic cells induce Th2 responses to inhaled antigen, leading to eosinophilic airway inflammation. *J Clin Invest* 2000;106:551–9.
116. Beaty SR, Rose CE, Sung S-SJ. Diverse and potent chemokine production by lung CD11b-high dendritic cells in homeostasis and in allergic lung inflammation. *J Immunol* 2007;178:1882–95.
117. Medoff BD, Seung E, Hong S, Thomas SY, Sandall BP, Duffield JS, et al. CD11b+ myeloid cells are the key mediators of Th2 cell homing into the airway in allergic inflammation. *J Immunol* 2009;182:623–35.
118. Hammad H, Plantinga M, Deswarte K, Pouliot P, Willart MAM, Kool M, et al. Inflammatory dendritic cells – not basophils – are necessary and sufficient for induction of Th2 immunity to inhaled house dust mite allergen. *J Exp Med* 2010;207:2097–111.
119. Sallmann E, Reininger B, Brandt S, Duschek N, Hoflehner E, Garner-Spitzer E, et al. High-affinity IgE receptors on dendritic cells exacerbate Th2-dependent inflammation. *J Immunol* 2011;187:164–71.
120. Wollenberg A, Kraft S, Hanau D, Bieber T. Immunomorphological and ultrastructural characterization of Langerhans cells and a novel, inflammatory dendritic epidermal cell (IDEC) population in lesional skin of atopic eczema. *J Invest Dermatol* 1996;106:446–53.
121. Annacker O, Pimenta-Araujo R, Burlen-Defranoux O, Bandeira A. On the ontogeny and physiology of regulatory T cells. *Immunol Rev* 2001;182:5–17.
122. Viglietta V, Baecher-Allan C, Weiner HL, Hafler DA. Loss of functional suppression by CD4+CD25+ regulatory T cells in patients with multiple sclerosis. *J Exp Med* 2004;199:971–9.
123. Hogan SP, Foster PS. Cytokines as targets for the inhibition of eosinophilic inflammation. *Pharmacol Ther* 1997;74:259–83.
124. Robinson DS, Hamid Q, Ying S, Tsicopoulos A, Barkans J, Bentley AM, et al. Predominant Th2-like bronchoalveolar T-lymphocyte population in atopic asthma. *N Engl J Med* 1992;326:298–304.
125. Hogan SP, Koskinen A, Matthaei KI, Young IG, Foster PS. Interleukin-5-producing CD4+ T cells play a pivotal role in aeroallergen-induced eosinophilia, bronchial hyperactivity, and lung damage in mice. *Am J Respir Crit Care Med* 1998;157:210–18.
126. Ray A, Cohn L. Th2 cells and GATA-3 in asthma: new insights into the regulation of airway inflammation. *J Clin Invest* 1999;104:985–93.
127. Lloyd CM, Hessel EM. Functions of T cells in asthma: more than just T(H)2 cells. *Nat Rev Immunol* 2010;10:838–48.
128. Soroosh P, Doherty TA. Th9 and allergic disease. *Immunology* 2009;127:450–8.
129. Souwer Y, Szegedi K, Kapsenberg ML, de Jong EC. IL-17 and IL-22 in atopic allergic disease. *Curr Opin Immunol* 2010;22:821–6.
130. Alcorn JF, Crowe CR, Kolls JK. TH17 cells in asthma and COPD. *Annu Rev Physiol* 2010;72:495–516.
131. Wills-Karp M. IL-12/IL-13 axis in allergic asthma. *J Allergy Clin Immunol* 2001;107:9–18.
132. Brusselle GG, Kips JC, Tavernier JH, van der Heyden JG, Cuvelier CA, Pauwels RA, et al. Attenuation of allergic airway inflammation in IL-4 deficient mice. *Clin Exp Allergy* 1994;24:73–80.
133. Zhu Z, Homer RJ, Wang Z, Chen Q, Geba GP, Wang J, et al. Pulmonary expression of interleukin-13 causes inflammation, mucus hypersecretion, subepithelial fibrosis, physiologic abnormalities, and eotaxin production. *J Clin Invest* 1999;103:779–88.
134. Bochner BS, Klunk DA, Sterbinsky SA, Coffman RL, Schleimer RP. IL-13 selectively induces vascular cell adhesion molecule-1 expression in human endothelial cells. *J Immunol* 1995;154:799–803.
135. Grunig G, Warnock M, Wakil AE, Venkayya R, Brombacher F, Rennick DM, et al. Requirement for IL-13 independently of IL-4 in experimental asthma. *Science* 1998;282:2261–3.
136. Wills-Karp M, Luyimbazi J, Xu X, Schofield B, Neben TY, Karp CL, et al. Interleukin-13: central mediator of allergic asthma. *Science* 1998;282:2258–61.
137. Mattes J, Yang M, Siqueira A, Clark K, MacKenzie J, McKenzie AN, et al. IL-13 induces airways hyperreactivity independently of the IL-4R $\alpha$  chain in the allergic lung. *J Immunol* 2001;167:1683–92.
138. Drolet J-P, Frangie H, Guay J, Hajoui O, Hamid Q, Mazer BD. B lymphocytes in inflammatory airway diseases. *Clin Exp Allergy* 2010;40:841–9.
139. Takhar P, Corrigan CJ, Smurthwaite L, O'Connor BJ, Durham SR, Lee TH, et al. Class switch recombination to IgE in the bronchial mucosa of atopic and nonatopic patients with asthma. *J Allergy Clin Immunol* 2007;119:213–18.
140. Vicario M, Blanchard C, Stringer KF, Collins MH, Mingler MK, Ahrens A, et al. Local B cells and IgE production in the oesophageal mucosa in eosinophilic oesophagitis. *Gut* 2010;59:12–20.
141. Singh V, Agrewala JN. Regulatory role of pro-Th1 and pro-Th2 cytokines in modulating the activity of Th1 and Th2 cells when B cell and macrophages are used as antigen presenting cells. *BMC Immunol* 2006;7:17.
142. Kaiko GE, Phipps S, Angkasekwinai P, Dong C, Foster PS. NK cell deficiency predisposes to viral-induced Th2-type allergic inflammation via epithelial-derived IL-25. *J Immunol* 2010;185:4681–90.
143. Hayakawa Y, Huntington ND, Nutt SL, Smyth MJ. Functional subsets of mouse natural killer cells. *Immunol Rev* 2006;214:47–55.
144. Thomas SY, Chyung YH, Luster AD. Natural killer T cells are not the predominant T cell in asthma and likely modulate, not cause, asthma. *J Allergy Clin Immunol* 2010;125:980–4.
145. Hayday AC.  $\gamma$  $\delta$  cells: a right time and a right place for a conserved third way of protection. *Annu Rev Immunol* 2000;18:975–1026.
146. Ferrick DA, Schrenzel MD, Mulvania T, Hsieh B, Ferlin WG, Lepper H. Differential production of interferon-gamma and interleukin-4 in response to Th1- and Th2-stimulating

- pathogens by gamma delta T cells in vivo. *Nature* 1995;373:255–7.
147. Born WK, Huang Y, Jin N, Huang H, O'Brien RL. Balanced approach of gammadelta T cells to type 2 immunity. *Immunol Cell Biol* 2010; 88:269–74.
  148. Spits H, Artis D, Colonna M, Diefenbach A, Di Santo JP, Eberl G, et al. Innate lymphoid cells – a proposal for uniform nomenclature. *Nat Rev Immunol* 2013;13:145–9.
  149. Fuchs A, Vermi W, Lee JS, Lonardi S, Gilfillan S, Newberry RD, et al. Intraepithelial type 1 innate lymphoid cells are a unique subset of IL-12- and IL-15-responsive IFN- $\gamma$ -producing cells. *Immunity* 2013;38:769–81.
  150. Bernink JH, Peters CP, Munneke M, Velde te AA, Meijer SL, Weijer K, et al. Human type 1 innate lymphoid cells accumulate in inflamed mucosal tissues. *Nat Immunol* 2013; 14:221–9.
  151. Spits H, Cupedo T. Innate lymphoid cells: emerging insights in development, lineage relationships, and function. *Annu Rev Immunol* 2012;30:647–75.
  152. Fallon PG. Identification of an interleukin (IL)-25-dependent cell population that provides IL-4, IL-5, and IL-13 at the onset of helminth expulsion. *J Exp Med* 2006;203: 1105–16.
  153. Klein Wolterink RG, Kleinjan A, van Nimwegen M, Bergen I, de Bruijn M, Levani Y, et al. Pulmonary innate lymphoid cells are major producers of IL-5 and IL-13 in murine models of allergic asthma. *Eur J Immunol* 2012;42: 1106–16.
  154. Imai Y, Yasuda K, Sakaguchi Y, Haneda T, Mizutani H, Yoshimoto T, et al. Skin-specific expression of IL-33 activates group 2 innate lymphoid cells and elicits atopic dermatitis-like inflammation in mice. *Proc Natl Acad Sci U S A* 2013;110:13921–6.
  155. Luci C, Reynders A, Ivanov II, Cognet C, Chiche L, Chasson L, et al. Influence of the transcription factor ROR $\gamma$ t on the development of NKp46+ cell populations in gut and skin. *Nat Immunol* 2008;10:75–82.
  156. Murphy PM. The molecular biology of leukocyte chemoattractant receptors. *Annu Rev Immunol* 1994;12:593–633.
  157. Gerard C, Gerard NP. The pro-inflammatory seven-transmembrane segment receptors of the leukocyte. *Curr Opin Immunol* 1994;6 140–5.
  158. Proost P, Wuyts A, Van Damme J. Human monocyte chemotactic proteins-2 and -3: structural and functional comparison with MCP-1. *J Leukoc Biol* 1996;59:67–74.
  159. Garcia-Zepeda EA, Rothenberg ME, Ownbey RT, Celestin J, Leder P, Luster AD. Human eotaxin is a specific chemoattractant for eosinophil cells and provides a new mechanism to explain tissue eosinophilia. *Nat Med* 1996;2: 449–56.
  160. Stellato C, Collins P, Ponath PD, Soler D, Newman W, La Rosa G, et al. Production of the novel C-C chemokine MCP-4 by airway cells and comparison of its biological activity to other C-C chemokines. *J Clin Invest* 1997;99: 926–36.
  161. Lu TX, Rothenberg ME. Diagnostic, functional, and therapeutic roles of microRNA in allergic diseases. *J Allergy Clin Immunol* 2013;132:3–13.
  162. Lu TX, Sherrill JD, Wen T, Plassard AJ, Besse JA, Abonia JP, et al. MicroRNA signature in patients with eosinophilic esophagitis, reversibility with glucocorticoids, and assessment as disease biomarkers. *J Allergy Clin Immunol* 2012;129:1064–75, e9.
  163. Case SR, Martin RJ, Jiang D, Minor MN, Chu HW. MicroRNA-21 inhibits toll-like receptor 2 agonist-induced lung inflammation in mice. *Exp Lung Res* 2011;37:500–8.
  164. Tsuchiya M, Kumar P, Bhattacharyya S, Chatteraj S, Srivastava M, Pollard HB, et al. Differential regulation of inflammation by inflammatory mediators in cystic fibrosis lung epithelial cells. *J Interferon Cytokine Res* 2013; 33:1211–9.
  165. Vicinus B, Rubie C, Faust SK, Frick VO, Ghadjar P, Wagner M, et al. miR-21 functionally interacts with the 3'UTR of chemokine CCL20 and down-regulates CCL20 expression in miR-21 transfected colorectal cancer cells. *Cancer Lett* 2012;316:105–12.
  166. Yao T, Lin Z. MiR-21 is involved in cervical squamous cell tumorigenesis and regulates CCL20. *Biochim Biophys Acta* 2012;1822: 248–60.
  167. Lippai D, Bala S, Csak T, Kurt-Jones EA, Szabo G. Chronic alcohol-induced microRNA-155 contributes to neuroinflammation in a TLR4-dependent manner in mice. *PLoS ONE* 2013; 8:e70945.
  168. Bhattacharyya S, Balakathiresan NS, Dalgard C, Gutti U, Armistead D, Jozwik C, et al. Elevated miR-155 promotes inflammation in cystic fibrosis by driving hyperexpression of interleukin-8. *J Biol Chem* 2011;286: 11604–15.
  169. Nazari-Jahantigh M, Wei Y, Noels H, Akhtar S, Zhou Z, Koenen RR, et al. MicroRNA-155 promotes atherosclerosis by repressing Bcl6 in macrophages. *J Clin Invest* 2012;122: 4190–202.
  170. Minshall EM, Cameron L, Lavigne F, Leung DY, Hamilos D, Garcia-Zepeda EA, et al. Eotaxin mRNA and protein expression in chronic sinusitis and allergen-induced nasal inflammation in seasonal allergic rhinitis. *Am J Respir Cell Mol Biol* 1997;17:683–90.
  171. Loetscher P, Seitz M, Baggiolini M, Moser B. Interleukin-2 regulates CC chemokine receptor expression and chemotactic responsiveness in T lymphocytes. *J Exp Med* 1996;184: 569–77.
  172. Loetscher M, Gerber B, Loetscher P, Jones SA, Piali L, Clark-Lewis I, et al. Chemokine receptor specific for IP10 and mig: structure, function, and expression in activated T-lymphocytes. *J Exp Med* 1996;184:963–9.
  173. D'Amico G, Frascaroli G, Bianchi G, Trandico P, Doni A, Vecchi A, et al. Uncoupling of inflammatory chemokine receptors by IL-10: generation of functional decoys. *Nat Immunol* 2000;1:387–91.
  174. Yamada H, Hirai K, Miyamasu M, Iikura M, Misaki Y, Shoji S, et al. Eotaxin is a potent chemotaxin for human basophils. *Biochem Biophys Res Commun* 1997;231:365–8.
  175. Luster AD, Rothenberg ME. Role of the monocyte chemoattractant protein and eotaxin subfamily of chemokines in allergic inflammation. *J Leukoc Biol* 1997;62:620–33.
  176. Alam R, Lett-Brown MA, Forsythe PA, Anderson-Walters DJ, Kenamore C, Kormos C, et al. Monocyte chemotactic and activating factor is a potent histamine-releasing factor for basophils. *J Clin Invest* 1992;89:723–8.
  177. Alam R, Forsythe P, Stafford S, Heinrich J, Bravo R, Proost P, et al. Monocyte chemotactic protein-2, monocyte chemotactic protein-3, and fibroblast-induced cytokine. Three new chemokines induce chemotaxis and activation of basophils. *J Immunol* 1994;153:3155–9.
  178. Kim CH, Broxmeyer HE. Chemokines for immature blood cells: effects on migration, proliferation and differentiation. In: Rothenberg ME, editor. *Chemokines in allergic diseases*. New York: Marcel Dekker; 2000. p. 227–61.
  179. Nagasawa T, Hirota S, Tachibana K, Takakura N, Nishikawa S, Kitamura Y, et al. Defects of B-cell lymphopoiesis and bone-marrow myelopoiesis in mice lacking the CXC chemokine PBSF/SDF-1. *Nature* 1996;382:635–8.
  180. Palframan RT, Collins PD, Williams TJ, Rankin SM. Eotaxin induces a rapid release of eosinophils and their progenitors from the bone marrow. *Blood* 1998;91:2240–8.
  181. Quackenbush EJ, Aguirre V, Wershil BK, Gutierrez-Ramos JC. Eotaxin influences the development of embryonic hematopoietic progenitors in the mouse. *J Leukoc Biol* 1997; 62:661–6.
  182. Peled A, Gonzalo JA, Lloyd C, Gutierrez-Ramos JC. The chemotactic cytokine eotaxin acts as a granulocyte-macrophage colony-stimulating factor during lung inflammation. *Blood* 1998;91:1909–16.
  183. Rollins BJ. Chemokines. *Blood* 1997;90: 909–28.
  184. Gunn MD, Tangemann K, Tam C, Cyster JG, Rosen SD, Williams LT. A chemokine expressed in lymphoid high endothelial venules promotes the adhesion and chemotaxis of naive T lymphocytes. *Proc Natl Acad Sci U S A* 1998; 95:258–63.
  185. Ward SG, Bacon K, Westwick J. Chemokines and T lymphocytes: more than an attraction. *Immunity* 1998;9:1–11.
  186. Zhang S, Lukacs NW, Lawless VA, Kunkel SL, Kaplan MH. Cutting edge: differential expression of chemokines in Th1 and Th2 cells is dependent on Stat6 but not Stat4. *J Immunol* 2000;165:10–14.
  187. Karpus WJ, Kennedy KJ. MIP-1 $\alpha$  and MCP-1 differentially regulate acute and relapsing autoimmune encephalomyelitis as well as Th1/Th2 lymphocyte differentiation. *J Leukoc Biol* 1997;62:681–7.
  188. Gu L, Tseng S, Horner RM, Tam C, Loda M, Rollins BJ. Control of TH2 polarization by the chemokine monocyte chemoattractant protein-1. *Nature* 2000;404:407–11.
  189. Toney LM, Cattoretto G, Graf JA, Merghoub T, Pandolfi PP, Dalla-Favera R, et al. BCL-6 regulates chemokine gene transcription in macrophages. *Nat Immunol* 2000;1:214–20.
  190. Mora JR, Iwata M, von Andrian UH. Vitamin effects on the immune system: vitamins A and D take centre stage. *Nat Rev Immunol* 2008; 8:685–98.

# The Developing Immune System and Allergy

ELYSIA M. HOLLAMS | PATRICK G. HOLT

## KEY POINTS

- The fetal immune system develops at least partial functional competence prior to birth, but whether this includes capacity to prime for subsequent postnatal production of the allergen-specific IgE antibody associated with persistent atopy remains contentious.
- Production of Th1 cytokines such as IFN- $\gamma$  is restricted during fetal development, presumably to prevent rejection of the fetus by the mother's immune system; relevant mechanisms include reversible promoter methylation.
- T cell populations in neonates are dominated by recent thymic emigrants, which respond to antigen with reduced specificity and have a reduced capacity to promote lasting T cell memory.
- Capacity for innate immune function in the neonatal period is a major determinant for risk of infection. Preterm babies, who are particularly susceptible to severe bacterial infections, have been shown to exhibit reduced Toll-like receptor function, a phenomenon also observed in infants with atopic mothers.
- Benign microbial stimulation, both postnatally and during intrauterine growth, promotes maturation of balanced innate and adaptive immune functions; delayed immune maturation in children is associated with heightened risk for allergy.

The prevalence of allergic diseases has risen markedly since the 1960s, particularly in the western world, and similar trends are emerging in developing countries transiting toward more affluent 'western' lifestyles. The diseases manifest initially during childhood, and have become more prevalent and persistent in successive birth cohorts, although there is evidence that prevalence may have peaked in several western countries. The importance of genetic susceptibility in the disease process is widely recognized, and it is further recognized that the ultimate expression of the disease is the result of complex interactions between genetic and environmental factors, neither of which have yet been comprehensively characterized. There is increasing evidence that the level of complexity inherent in the pathogenesis of allergic diseases may be even greater than is currently contemplated, as an additional set of crucial factors appear to be involved. Notably, it appears likely that the ultimate effect(s) of these 'gene  $\times$  environment' interactions within individuals may also be related to the developmental status of the relevant target tissues at the time the interactions occur. Examples of the latter,

discussed below, are elements of innate and adaptive immune function and aspects of airways function relevant to atopic asthma.

## Immune Function during Fetal Life

The initial stage of hematopoiesis in the human fetus occurs in extraembryonic mesenchymal tissue and in the mesoderm of the yolk sac. Pluripotent erythroid and granulo-macrophage progenitors are detectable in the latter at around the fourth week of gestation (Box 6-1). These cells appear subsequently in the fetal circulation and by weeks 5 to 6 in the liver, which at that stage of development is the major site of hematopoiesis. Within the liver, the interactions between stromal cells and hematopoietic cells play an important role in regulation. Expression of fibronectin by stromal cells is increased during the second trimester and is believed to result in enhanced proliferation and differentiation of hematopoietic cells.<sup>1</sup> The spleen and thymus are seeded from the liver, and by the eighth week of development CD7<sup>+</sup> precursor cells are found in the thymus,<sup>2-4</sup> whereas stem cells do not appear in bone marrow until around the 12th week of gestation.<sup>5</sup> T cells recognizable by expression of characteristic TcR/CD3 are found in peripheral lymphoid organs from weeks 13 to 15 of gestation onwards,<sup>6-8</sup> despite the lack of well-defined thymic cortical and medullary regions and mature epithelial components.<sup>3</sup> These early T cells also express CD2 and CD5.<sup>4</sup> The maturation of nonlymphoid components within peripheral lymphoid tissues progresses even more slowly and takes up to 20 weeks.<sup>8-11</sup>

It is feasible that the fetal gastrointestinal tract may be an additional site for extrathymic T cell differentiation in the human fetus, as has been reported in the mouse.<sup>12</sup> T cells are detectable in the intestinal mucosa by 12 weeks of gestation,<sup>13</sup> and many of these express the CD8 $\alpha\alpha$  phenotype, in particular within Peyer's patches.<sup>14</sup> In the mouse, CD8 $\alpha\alpha$  cells appear to be thymus independent and are believed to develop in the gut. Although there is no direct evidence for this in humans, it is noteworthy that fetal gut lamina propria lymphocytes are initially an actively proliferating population as indicated by constitutive expression of Ki67, and there is little or no overlap between gut-derived and blood-derived TcR $\beta$  transcripts.<sup>15</sup>

The gut mucosa may also be a major site for differentiation of TcR $\gamma/\delta$  cells during fetal life. Rearranged TcR $\delta$  genes are first detectable in the gut at 6 to 9 weeks of gestation,<sup>16</sup> which is earlier than is observed in the thymus. The liver is another significant extrathymic site for TcR $\gamma/\delta$  differentiation in humans, including a unique subset expressing CD4.<sup>17</sup>

The capacity to respond to polyclonal stimuli such as phytohemagglutinin (PHA) is first seen at 15 to 16 weeks of gestation.<sup>18</sup> The degree to which the fetal immune system can respond



**BOX 6-1 KEY CONCEPTS****MATURATION OF THE IMMUNE SYSTEM**

- Weeks 5–6 of gestation: pluripotent erythroid and granulocyte-macrophage progenitors are detected in the liver
- Week 8 of gestation: CD7<sup>+</sup> precursor cells found in the thymus
- Week 12 of gestation: stem cells appear in bone marrow
- Weeks 13–15 of gestation: T cells found in peripheral lymphoid organs
- Weeks 15–16 of gestation: fetal T cells respond to mitogen
- IgM responses develop in fetus following maternal vaccination
- Infant T cells express CD1, PNA and CD38, indicative of mature thymocytes
- Proportion of CD45RO<sup>+</sup> CD4<sup>+</sup> T cells increases from <10% at birth to >65% in adulthood, reflecting progressive antigenic exposure
- Adult peripheral blood T cells express CCR-1, -2, -5, and -6 and CXCR-3 and CXCR-4, whereas cord blood expresses only CXCR-4, reflecting decreased capacity to respond to proinflammatory signals at birth
- At infancy, cytotoxic effector functions and capacity to drive B cell immunoglobulin production are attenuated

to foreign antigens has not been clearly established. On the one hand, the offspring of mothers infected during pregnancy with a range of pathogens including mumps,<sup>19</sup> ascariis,<sup>20</sup> malaria,<sup>21</sup> schistosomes<sup>22</sup> and helminths<sup>23</sup> display evidence of pathogen-specific T cell reactivity at birth, whereas infection with other organisms such as toxoplasma<sup>24</sup> may induce tolerance. However, more recent studies have detected significant populations of T cells in cord blood that express the effector memory phenotype, even in the absence of any evidence of previous maternal infection.<sup>25</sup> Additionally, vaccination of pregnant women with tetanus toxoid results in the appearance of IgM in the fetal circulation that is indicative of fetal T cell sensitization.<sup>26</sup> Similarly, vaccination of pregnant women against influenza results in the presence of influenza-specific IgM in cord blood, and virus-specific CD8<sup>+</sup> T cells detected by the use of MHC tetramers.<sup>27</sup> There is also a variety of evidence based on *in vitro* lymphoproliferation of cord blood mononuclear cells<sup>28</sup> and recently the presence of low levels of IgE in cord blood<sup>29,30</sup> which suggests that environmental antigens (including dietary and inhalant allergens) to which pregnant women are exposed may in some circumstances prime T cell responses transplacentally. However these conclusions have been challenged on the basis of a variety of evidence of low specificity of cord blood responses to allergen (further discussion below) and on the kinetics of postnatal development of allergen-specific Th memory,<sup>31</sup> and the issue remains contentious.<sup>32</sup> The recent discovery that the placenta is not sterile, but rather hosts a distinct microbiome in healthy pregnancy, is sure to stimulate much additional research into fetal immune function.<sup>33</sup>

Studies examining lymphocyte subsets in cord blood from babies born at gestational ages between 20 and 42 weeks found that the proportion of cord natural killer (NK) cells increased with gestational age, while the proportion of CD4<sup>+</sup> cells and the ratio of CD4<sup>+</sup> : CD8<sup>+</sup> cells decreased.<sup>34,35</sup> Despite the lack of significant numbers of CD4<sup>+</sup> and CD8<sup>+</sup> CD45RO<sup>+</sup> T cells in cord blood, fetal spleen and cord blood samples from premature infants contain these cells in relatively high frequency.<sup>36</sup> These 'postactivated' or 'memory' T cells were unresponsive to recombinant IL-2, suggesting they may have been anergized by

earlier contact with self or environmental antigens.<sup>36</sup> CD4<sup>+</sup> CD25<sup>+</sup> T regulatory cells are detected in fetal lymphoid tissue, and they have been shown to have a suppressive effect on fetal CD4<sup>+</sup> and CD8<sup>+</sup> T cells expressing the activation antigen CD69.<sup>37</sup> Fetal thymic exposure to high-avidity TcR ligand has been shown to promote development of T regulatory cells in mice, while exposure to low-affinity TcR ligand did not; it appears that T regulatory cells require a higher ligand avidity for positive selection than conventional T cells.<sup>38</sup> Interestingly, expression and function of T regulatory cells has been found to be impaired at birth in the offspring of atopic mothers.<sup>39</sup>

These findings collectively suggest that the fetal immune system develops at least partial functional competence before birth but lacks the full capacity to generate sustained immune responses; although IgM responses develop in the fetus following maternal tetanus vaccination, there is no evidence of class-switching in the offspring until they are actively vaccinated.<sup>26</sup> Given the fact that the fetal immune system can generate at least primary immune responses against external stimuli, the question arises as to how immune responses within or in close contact with the fetal compartment are regulated. The necessity for tight control of these responses becomes obvious in light of findings that a variety of T cell cytokines are exquisitely toxic to the placenta.<sup>40</sup> Part of this control may be at the level of transcription factor expression.

It is also pertinent to question how potential immunostimulatory interactions between cells derived from fetal and maternal bone marrow are regulated at the fetomaternal interface. It has been clearly demonstrated that fetal cells readily traffic into the maternal circulation,<sup>41–45</sup> potentially sensitizing the maternal immune system against paternal HLA antigens present on the fetal cells. However, it is clear that the maternal immune system in the vast majority of circumstances successfully eradicates fetal cells from the peripheral circulation while remaining functionally tolerant of the fetus.<sup>46</sup> This suggests that tolerance of the fetal allograft is a regionally controlled process that is localized to the fetomaternal interface.

The mechanisms that regulate the induction and expression of immune responses in this milieu are complex and multilayered. The first line of defense appears to involve tolerogenic HLA-G-expressing, IL-10-producing dendritic cells detectable in the maternal circulation and in the decidua,<sup>47</sup> and the activity of these is complemented by decidual macrophage populations.<sup>48</sup> The tolerogenic activity of these cell populations is supported via an immunosuppressive 'blanket' maintained through the local production within the placenta by trophoblasts and macrophages of metabolites of tryptophan generated via indoleamine 2,3-dioxygenase, which are markedly inhibitory against T cell activation and proliferation.<sup>49</sup> Constitutive production of high levels of IL-10 by placental trophoblasts provides a second broad-spectrum immunosuppressive signal to dampen local T cell responses,<sup>50</sup> as well as the homeostatic function of alternatively activated macrophages.<sup>51</sup>

An additional line of defense involves mechanisms that operate to protect against T cell activation events, which evade suppression via these pathways. These include the expression of FasL on cells within the placenta providing a potential avenue for apoptosis-mediated elimination of locally activated T cells,<sup>52,53</sup> NK cells that selectively antagonize Th-17 cell activation,<sup>54</sup> and the presence of maternally derived CD4<sup>+</sup> CD25<sup>+</sup> T regulatory cells, which are recruited to the maternofetal interface where they act to dampen fetus-specific responses.<sup>55</sup> These



mechanisms are complemented by a series of pathways that operate to selectively dampen production at the fetomaternal interface of Th1 cytokines, in particular interferon-gamma (IFN- $\gamma$ ). This cytokine plays an important role in implantation;<sup>56</sup> however, if it is produced in suprathreshold levels at later stages of pregnancy, triggered for example by local immune responses against microbial or allo-antigens, IFN- $\gamma$  (and other Th1 cytokines) can potentially cause placental detachment and fetal resorption.<sup>57,58</sup> These Th2-trophic mechanisms involve local production of a range of immunomodulators including IL-10,<sup>50</sup> which programs antigen-presenting cells (APCs) for Th2 switching;<sup>59</sup> progesterone, which directly inhibits IFN- $\gamma$  gene transcription;<sup>60–62</sup> progesterone and estradiol, which both inhibit the NF- $\kappa$ B pathway in monocytes;<sup>63</sup> and PGE<sub>2</sub>, which promotes Th2 switching via effects upon APCs, in particular dendritic cells.<sup>59</sup> Circulating myeloid and plasmacytoid dendritic cells (mDC and pDC) in late pregnancy appear to be constrained with respect to the level of activation they can achieve, and it has been suggested that this mechanism may be mediated via the glycoprotein hormone activin-A.<sup>64</sup>

## Resistance to Infection during Infancy

Infancy represents a period of high susceptibility to infection with a range of pathogens including bacteria and fungi<sup>65</sup> and, in particular, viruses.<sup>66–68</sup> The expression of cell-mediated immunity during active viral infection is attenuated in infants compared to older age groups,<sup>69–71</sup> and the subsequent generation of virus-specific immunologic memory is also inefficient.<sup>72</sup> These findings suggest that a range of developmentally related deficiencies in innate and adaptive immunologic mechanisms are operative in neonates.

## Surface Phenotype of T Cells in Early Life

Total lymphocyte counts in peripheral blood are higher in infancy than in adulthood,<sup>73</sup> and at birth T cell levels are twice those of adults. Longitudinal studies on individual infants indicate a further rapid doubling in T cell numbers in the circulation during the first 6 weeks of life, which is maintained throughout infancy.<sup>74</sup> Surface marker expression on infant T cells differs markedly from that observed in adults. The most noteworthy characteristics are frequent expression of CD1,<sup>75</sup> PNA,<sup>76</sup> CD31<sup>77</sup> and CD38.<sup>74,78,79</sup> These four antigens are considered to mark mature thymocytes as opposed to circulating 'mature' naïve T cells.

Analyses performed on CD38<sup>+</sup> cord blood cells have reinforced this view. In particular, animal model studies on thymic output have led to the development of an accurate technique for phenotypic identification of recent thymic emigrants (RTE), which are newly produced peripheral naïve T cells that retain a distinct phenotypic signature of recent thymic maturation that distinguishes them from long-lived naïve T cells produced at remote sites. This approach involves the measurement of T cell receptor excision circles (TRECs), which are stable extrachromosomal products generated during the process of variable/diverse/joining (VDJ) TcR gene rearrangement. TRECs are not replicated during mitosis, becoming diluted with each round of cell division. Hassan and Reen<sup>79</sup> have demonstrated that the majority of circulating CD4<sup>+</sup> CD45RA<sup>+</sup> human T cells at birth

are RTE, as reflected by their high level of TRECs. These researchers also demonstrated that, analogous to thymocytes, the RTE were highly susceptible to apoptosis,<sup>79</sup> and unlike mature adult-derived CD4<sup>+</sup> CD45RA<sup>+</sup> naïve T cells, they were uniquely responsive to common  $\gamma$ -chain cytokines, particularly IL-7.<sup>79,80</sup> Whereas IL-7 promotes their proliferation and survival, IL-7-exposed RTE could not reexpress recombination-activating gene-2 gene expression *in vitro*. These findings suggest that postthymic naïve peripheral T cells in early infancy are at a unique stage in ontogeny as RTE, during which they can undergo homeostatic regulation including survival and antigen-independent expansion, while maintaining their preselected TcR repertoire.<sup>79</sup>

Studies examining the patterns of postnatal change in T cell surface marker expression have identified relatively high numbers of T cells coexpressing both CD4 and CD8 during infancy, which is also a hallmark of immaturity.<sup>74,81,82</sup> In contrast, the expression of CD57 on T cells, which marks non-MHC-restricted cytotoxic cells, is infrequent, as are T cells coexpressing IL-2 and HLA-DR, which is indicative of recent activation.<sup>82</sup> The expression of other activation markers such as CD25, CD69 and CD154 is also low.<sup>74</sup>

Of particular interest in relation to the understanding of overall immune competence during postnatal life are changing patterns of surface CD45RA and CD45RO on T cells. T cells exported from the thymus express the CD45RA isoform of the leukocyte common antigen CD45, and after activation switch to CD45RO expression. Most postactivated neonatal CD4<sup>+</sup> CD45RO<sup>+</sup> T cells are short-lived and die within a matter of days, but a subset of these is believed to be programmed to enter the long-lived recirculating T cell compartment as T memory cells.<sup>83</sup> The proportion of CD45RO<sup>+</sup> cells within the CD4<sup>+</sup> T cell compartment progressively increases from a baseline of less than 10% at birth, up to 65% in adulthood, reflecting age-dependent accumulation of antigenic exposure.<sup>74,82–88</sup> The rate of increase within the TcR $\alpha/\beta$  and TcR $\gamma/\delta$  populations is approximately equivalent and is slightly more rapid for CD4<sup>+</sup> T cells relative to CD8<sup>+</sup> T cells.<sup>86</sup> The relative proportion of CD45RO<sup>+</sup> putative memory T cells attains adult-equivalent levels within the teen years,<sup>82,86</sup> although the population spread during the years of childhood is very wide.<sup>86</sup> This suggests substantial heterogeneity within the pediatric population in the efficiency of mechanisms regulating the generation of T helper memory.

## Functional Phenotype of T Cells during Infancy and Early Childhood

T cell function during infancy exhibits a variety of qualitative and quantitative differences relative to that observed in adults. It has been demonstrated when employing a limiting dilution analytic system that at least 90% of peripheral blood CD4<sup>+</sup> T cells from adults can give rise to stable T cell clones, whereas the corresponding (mean) figure for immunocompetent T cell precursors in infants was less than 35%.<sup>89</sup> Moreover, the cytokine production profile of T cell clones from infants displayed a prominent Th2 bias,<sup>89</sup> which may be related to the recently described predilection of T cells from this age group for preferential expression of the master Th2 regulator GATA3.<sup>77</sup> Cloning frequencies within the infant population were bimodally distributed, with a significant subset of ostensibly normal

healthy subjects displaying particularly low cloning frequencies of no more than 20%.<sup>89</sup>

In apparent contrast to these findings, the magnitude of initial T cell proliferation induced by polyclonal T cell mitogens such as PHA in short-term cultures is higher at birth than subsequently during infancy and adulthood.<sup>90,91</sup> However, proliferation is not sustained, which may reflect the greater susceptibility of neonatal T cells to apoptosis post activation<sup>79</sup> and/or decreased production of IL-2.<sup>92,93</sup> In contrast, activation induced by TcR stimulation<sup>94</sup> and cross-linking CD2<sup>93,95</sup> or CD28<sup>96</sup> is reduced.

In addition to these deficiencies, neonatal T cells are hyperresponsive to IL-4<sup>97</sup> and hyporesponsive to IL-12<sup>98</sup> compared to adults, the latter being associated with reduced IL-12 receptor expression.<sup>99</sup> Neonates also have reduced capacity to produce IL-12, which can last into childhood; work from our laboratory has suggested that slow maturation of IL-12 synthetic capacity can be attributed to deficiencies in the number and/or function of dendritic cells.<sup>100</sup>

Neonatal T cells exhibit heightened susceptibility to anergy induction post stimulation with bacterial superantigen, employing protocols that do not tolerize adult T cells.<sup>101,102</sup> This has been ascribed to deficient IL-2 production<sup>102</sup> but may alternatively be related to developmentally related deficiencies in the Ras signaling pathway, which have been associated with secondary unresponsiveness to alloantigen stimulation by T cells from neonates.<sup>103</sup> Additional aberrations in intracellular signaling pathways reported in neonatal T cells include phospholipase C and associated Lck expression,<sup>104</sup> protein kinase C<sup>105</sup> and CD28, which is associated with dysfunction in FasL-mediated cytotoxicity<sup>106</sup> and reduced NF $\kappa$ B production.<sup>96</sup>

Profiles of chemokine receptor expression and responsiveness in neonatal T cells have been observed to differ distinctly from those in adults. In particular, adult peripheral blood T cells expressed CCR-1, -2, -5, -6 and CXCR-3 and CXCR-4, whereas those from cord blood expressed only CXCR-4, reflecting markedly attenuated capacity to respond to signals from inflammatory foci.<sup>107</sup> Additional differences have been observed between T cells from normal and preterm infants, particularly with respect to CCR4 and  $\alpha$ 4 $\beta$ 7 expression.<sup>108</sup>

Evidence from a range of studies indicates that both cytotoxic effector functions<sup>109,110</sup> and capacity to provide help for B cell immunoglobulin production<sup>109–113</sup> are attenuated during infancy. These functional deficiencies are likely to be the result of a combination of factors that include decreased expression of CD40L,<sup>109,111,112</sup> reduced expression of cytokine receptors<sup>99,114</sup> and decreased production of a wide range of cytokines following stimulation.<sup>89,92,115–121</sup> The mechanism(s) underlying these reduced cytokine responses are unclear, but factors intrinsic to the T cells themselves,<sup>89,122</sup> as well as those involving accessory cell functions,<sup>122–124</sup> appear to be involved.

The IFN- $\gamma$  gene is under tight regulation during fetal development, presumably to prevent rejection of the fetus by the mother's immune system that may result from excessive IFN- $\gamma$  in the uterine environment.<sup>125</sup> Expression of IFN- $\gamma$  is modulated in part at the epigenetic level via gene methylation, with transcriptional activity inhibited by hypermethylation of DNA. This laboratory has demonstrated hypermethylation at multiple CpG sites in the proximal promoter region of the IFN- $\gamma$  gene in CD4<sup>+</sup> CD45RA<sup>+</sup> T cells in cord blood relative to their adult counterparts.<sup>126</sup> We subsequently demonstrated that *in vitro* differentiation of CD4(+) T cells down the Th1, but not Th2,

pathway is accompanied by progressive demethylation of CpG sites in the IFN- $\gamma$  promoter, which is most marked in neonatal cells.<sup>127</sup> While atopy development by age 2 was not associated with variations in methylation patterns in cord blood T cells, IFN- $\gamma$  promoter methylation was reduced in CD8(+) T cells from atopic children in the age range in which hyperproduction of IFN- $\gamma$  has recently been identified as a common feature of the atopic phenotype.

It has been proposed that many naïve neonatal T cells may have low-affinity TcRs and reduced affinity for T cell activation, and that expansion may take place without production of conventional memory T cells. If this is the case, cytokine responses to antigens in cord blood might have little relevance to immune responses to the same antigens later in childhood. It is possible that the relevance of cord blood responses to those in later life varies according to antigen. Findings from our laboratory have suggested that the allergen reactivity of neonatal T cells consists predominantly of a default response by recent thymic emigrants, which provide an initial burst of short-lived cellular immunity in the absence of conventional T cell memory.<sup>128</sup> This response appears to be limited by parallel activation of regulatory T cells, which arise as a result of these initial allergen encounters.<sup>128,129</sup> There is an inverse relationship between the numbers of circulating regulatory and memory CD4<sup>+</sup> T cells both during pregnancy<sup>130</sup> and postnatally.<sup>131</sup> The frequency of regulatory T cells at birth is inversely associated with gestational age<sup>130,132–135</sup> and this difference may persist for a significant period into infancy.<sup>133</sup>

Our studies in a longitudinal birth cohort comprising children at high risk (i.e. one or both parents allergic) examined how immune function in early childhood relates to infection and development of allergy. We found that priming of Th2 responses associated with persistent house dust mite (HDM)-IgE production in a high-risk cohort occurred entirely postnatally, as HDM reactivity in cord blood appeared to be nonspecific and was unrelated to subsequent development of allergen-specific Th2 memory or IgE.<sup>31</sup> However, a different picture emerged when polyclonal responses to mitogen were assessed by measuring PHA-induced cytokines from cultured cord blood mononuclear cells (CBMC) from cohort subjects, which correlated with frequency/intensity of respiratory infections up to age 5.<sup>136</sup> The ratio of PHA-induced IL-10 : IL-5 was highly predictive of subsequent severe infection, with high IL-5 responses associated with increased infection risk and the converse for high IL-10 responses. We suggest that the relevant underlying mechanisms may involve IL-10-mediated feedback inhibition of IL-5-dependent eosinophil-induced inflammation, which is a common feature of antiviral responses in early childhood.<sup>136</sup> Additionally, the same immunophenotype appears to be associated with reduced capacity to produce IL-21,<sup>136</sup> and it is significant that a series of studies point to a crucial role for this cytokine in resistance to persistent viral infection.<sup>137–139</sup> The relevance of cord blood responses to immune function in later life may depend upon environmental factors and associated exposures to infection during pregnancy. A study performed in a malaria-endemic region of Kenya examining mononuclear cell responses to malaria antigen found that the fine specificity of lymphocyte proliferation and cytokine secretion was similar in cord and adult blood mononuclear cells.<sup>140</sup> Stimulation with overlapping peptides to identify dominant malaria T cell epitopes also showed that cord blood cells from neonates whose mothers who had been malaria-infected during pregnancy were

4-fold more likely to acquire a peptide-specific immune response. It was therefore proposed that the fetal malaria response functions in a competent adaptive manner, which may help to protect neonates from severe malaria during infancy.<sup>140</sup>

Recent research has identified a new subset of T helper cells that produce IL-17. These ‘Th17’ cells appear to mediate tissue inflammation by supporting neutrophil recruitment and survival, proinflammatory cytokine production by structural cells and matrix degradation (reviewed in reference 141). Studies have shown that all IL-17-producing cells originate exclusively from CD161<sup>+</sup> naïve CD4<sup>+</sup> T cells of umbilical cord blood and the postnatal thymus in response to a combination of IL-1 $\beta$  and IL-23.<sup>142</sup> It has also been shown that human naïve CD4<sup>+</sup> T cells can give rise to either Th1 or Th17 cells in the presence of IL-1 $\beta$  and IL-23, with IL-12 presence determining Th1 development. Additionally, a subset of IL-17-producing cells possessed the ability to produce IFN- $\gamma$  even after their development from CD4<sup>+</sup> T cells, perhaps representing an intermediate Th1/Th17 phenotype.<sup>142</sup> A recent study comparing T cells from preterm and term infants with those from adults also suggests that Th17 cell capacity may be inversely related to developmental age, leading to a relative Th17 bias in early life,<sup>143</sup> and this may reflect parallel developmental kinetics for the Th17-trophic cytokines IL-6 and IL-23.<sup>144</sup> Expression of full Th17 activity in infants may require specific stimuli such as viral infection, exemplified by respiratory syncytial virus (RSV).<sup>145</sup>

## Innate Immunity in Neonates

There is a high level of interconnectivity between the innate and adaptive arms of the immune system. Competent adaptive immune function is important for switching off innate immune responses to prevent them from overshooting and causing bystander damage to host tissues, while defects in innate immunity appear to play a role in the development of a number of inflammatory diseases including allergy. Toll-like receptors (TLRs) are central to the function of the innate immune system, and there are at least 10 known human TLRs that recognize pattern motifs present in bacteria, viruses or other prokaryotes. Many aspects of TLR-associated functions are inefficient in early life,<sup>146</sup> though patterns of functional maturation across the population are complex and heterogeneous.<sup>144</sup>

The capacity of the innate immune system to recognize and rapidly respond to pathogens via TLRs is a major determinant of risk for infection during this crucial period, exemplified by recent findings linking respiratory-related hospitalization in infants and reduced capacity of their monocytes for viral-induced IFN- $\gamma$  production.<sup>147</sup> Infants, especially those born prematurely, are particularly susceptible to severe bacterial infections. A study investigating mechanisms behind this phenomenon demonstrated that TLR4 expression is dependent on gestational aging; preterm infants show decreased expression of TLR4 on monocytes compared to full-term newborns; both showed lower expression than adults.<sup>148</sup> Similarly, cytokine production following lipopolysaccharide (LPS) stimulation was significantly lower in whole blood cultures from preterm compared to full term infants; both had lower production than adults. Subsequent studies examining TLR2 expression found that although TLR2 levels did not differ between preterm and full-term neonates, levels of the proximal downstream adapter molecule myeloid differentiation factor MyD88 were

significantly reduced in preterm newborns, along with cytokine responses to TLR2 ligand.<sup>149</sup>

Studies examining the effect of breastfeeding on neonatal innate immune response have found that breast milk from days 1 to 5 postpartum negatively modulated TLR2 and TLR3 ligand responses, while enhancing those of TLR4 and 5.<sup>150</sup> Breast milk has been found to contain sCD14 and sTLR2 in addition to unidentified TLR-modulatory factors.<sup>151,152</sup> It has been suggested that the differential modulation of TLR function by breast milk may serve to promote efficient response to potentially harmful LPS-producing Gram-negative bacteria via TLR4 while allowing the establishment of Gram-positive bifidobacteria as the predominant intestinal microflora.<sup>150</sup>

Neonatal immune responses to microbial stimuli appear to be affected by maternal allergy. Children with atopic mothers have been observed to have significantly lower expression in cord blood monocytes of TLR2 and TLR4 than their mothers both before and after microbial stimulation, a disparity that was not seen between nonatopic mothers and their children.<sup>153</sup> In addition, CBMC from children with atopic mothers produced less IL-6 in response to peptidoglycan stimulation than those from children with nonatopic mothers.<sup>153</sup> In another study, CBMC stimulation with the TLR2 ligand peptidoglycan led to secretion of IL-10 and induction of FOXP3 that varied according to maternal atopy; CBMC from newborns with maternal atopy showed reduced induction of these cytokines compared to those without maternal atopy.<sup>154</sup>

A study from our laboratory focussed on the ontogeny of the innate immune system and examined the cytokine secretory capacity of mononuclear cells from subjects at various ages between birth and adulthood.<sup>155</sup> Cells were primed with IFN- $\gamma$  then stimulated with LPS; production of IL-6, IL-10, IL-12, IL-18, IL-23, TNF- $\alpha$  and myxovirus resistance protein A (MXA: a cytokine induced by type I interferon in response to virus infection) was measured and compared. The developmental pattern between 1 year and 13 years showed that levels of all cytokines increased with age, with levels of some cytokines further increasing in adulthood. However, a subset of cytokines showed hyperexpression in CBMC. There appeared to be major differences in developmental regulation between the MyD88-dependent (TNF- $\alpha$ , IFN- $\gamma$ , IL-6 and IL-10) cytokines, which were hyperexpressed by CBMC relative to infant peripheral blood mononuclear cells (PBMC), compared to the MyD88-independent cytokines (IL-12, IL-18, IL-23 and MXA) which were expressed at lower levels in both CBMC and PBMC from infants than in PBMC from older age groups,<sup>155</sup> and similar dichotomous patterns of production capacity in neonates between different classes of cytokines have been reported in several more recent studies.<sup>156–160</sup> A factor present in neonatal plasma has recently been implicated in the polarization of neonatal cells toward the low IL-12/high IL-10 producer phenotype,<sup>161</sup> but this finding has yet to be confirmed.

There appears to be a gradual maturation of phagocytic capacity by innate immune cells over time. The phagocytic activity of fetal neutrophils and monocytes has been observed to be significantly lower than that of healthy neonates and adults, and a direct relationship between gestational age and number of phagocytosing granulocytes has been demonstrated.<sup>162</sup> Similarly, the activity of NK cells in infants is correlated with gestational age<sup>40,163–165</sup> and is significantly impaired at baseline compared to children and adults.<sup>34</sup> However, following stimulation with priming agents exemplified by IL-18



and IL-12<sup>163</sup> or single-stranded RNA,<sup>166</sup> neonatal cells rapidly develop higher levels of IFN- $\gamma$  and cytolytic activity than are seen in adults, suggesting that this arm of innate immunity may play a significant role in host defense during this life period.

A series of recent studies have added a further layer of complexity to this picture, with the demonstration that developmental heterogeneity across the spectrum of innate immune functions also varies in relation to ethnic background and/or geographic location of study groups;<sup>167–170</sup> similar observations apply to innate regulatory T cell activity in early life.<sup>168</sup>

## B Cell Function in Early Life

Certain aspects of B cell function in neonates appear unique in relation to adults. In particular, large numbers of neonatal B cells express CD5,<sup>171,172</sup> together with activation markers such as IL-2R and CD23.<sup>171</sup> It has been postulated that these CD5<sup>+</sup> B cells act as a 'first line of defense' in primary antibody responses in neonates utilizing a preimmune repertoire, in contrast to CD5<sup>-</sup> B cells in which response patterns are acquired following antigen contact.<sup>173</sup> Unlike adult B cells, these neonatal B cells proliferate readily in the presence of IL-2 or IL-4 without requirement of further signals.<sup>171,174–176</sup> An additional (albeit less frequent) neonatal B cell subset expresses IgD, IgM, CD23 and CD11b, is CD5 variable, and spontaneously secretes IgM antibodies against a range of autoantigens.<sup>171</sup>

Conventional B cell function, that is, antibody production following infection or vaccination, is reduced in infants relative to adults,<sup>72</sup> and some *in vitro* studies suggest that this may be related to a defect in isotype switching.<sup>177</sup> The relative contributions of the T cell and B cell compartments to this deficiency in immunoglobulin production are widely debated, but the consensus is that both cell types play a role.

As noted previously, T cells in infants do not readily express high levels of CD40L<sup>109–113</sup> unless provided with particularly potent activating stimuli.<sup>178</sup> CD40L represents a critical signal for T helper cell-induced class switching<sup>179</sup> and the generally low expression on neonatal T cells may thus be a limiting factor in the process. Reduced T cell cytokine production<sup>89,92,115–121</sup> may further exacerbate the problem. However, although immunoglobulin production by neonatal B cells is low in the presence of neonatal T helper cells, production levels can be markedly improved if mature T helper cells or adequate soluble signals are provided.<sup>113,174,180</sup> However, the neonatal B cells still fail to reach adult-equivalent levels of production, suggesting that an intrinsic defect also exists. In this regard, it is pertinent to note that functional immaturity within the B cell compartment has recently been identified as a predictor of high risk for later development of allergic disease.<sup>181</sup>

Growing interest in the human microbiome in health and disease has reawakened interest in the role of gut flora in the development of the overall B cell repertoire,<sup>182</sup> in particular the stimulatory effect of early gut colonization on B memory cell expansion.<sup>183,184</sup> An additional area of B cell immunobiology that is set to have a major impact in the area of immune development and allergy pertains to the activity of regulatory B cell populations, which are hypothesized to play a direct role in control of allergic inflammation;<sup>185,186</sup> moreover, a related population of B cells has been identified in neonatal thymic tissue, which appears to stimulate the generation of regulatory T cells.<sup>187</sup>

## Antigen-Presenting Cell Populations

The key 'professional' antigen-presenting cell (APC) populations in this context are the mononuclear phagocytes (MPCs), dendritic cells (DCs) and B cells. The precise role of each cell type in different types of immune response is not completely clear, although it is evident that DCs represent the most potent APC for priming the naïve T cell system against antigens encountered at low concentrations (e.g. virus and environmental allergens).

Ontogenic studies on human MPCs have been essentially limited to blood monocytes. Although neonatal populations appear comparable to those of adults in number and phagocytic activity,<sup>188,189</sup> they display reduced chemotactic responses<sup>190</sup> and reduced capacity for secretion of inflammatory cytokines such as TNF- $\alpha$ .<sup>191</sup> Their capacity to present alloantigen to T cells is reportedly normal,<sup>192</sup> but they display reduced levels of MHC class II expression.<sup>193</sup> Several studies have implicated poor accessory cell function of infant blood monocytes as a co-factor in the reduced IFN- $\gamma$  responses of infant T cells to polyclonal mitogens such as PHA,<sup>122–124</sup> possibly as a result of diminished elaboration of co-stimulator signals. Macrophage populations at mucosal sites such as the lung and airways have important immunoregulatory roles in adults,<sup>194</sup> but it is not clear whether these mechanisms are operative in early life. A murine study from our group indicates lower levels of expression of immunomodulatory molecules, including IL-10 and nitric oxide, by lung macrophages during the neonatal period.<sup>195</sup>

B cells are also recognized as important APCs, in particular for secondary immune responses.<sup>196,197</sup> In murine systems, it has been demonstrated that neonatal B cells function poorly as APCs relative to their adult counterparts and do not reach adult-equivalent levels of activity until after weaning.<sup>188,198</sup>

As noted previously, DCs are the most potent APC population in adult experimental animals for initiation of primary immunity and in this regard have been designated as the 'gatekeepers' of the immune response.<sup>199</sup> The distribution and phenotypes of these cells appear comparable in murine and human tissues, and it is accordingly reasonable to speculate that the proposed role of murine DCs as the link between the innate and adaptive arms of the immune system<sup>199–202</sup> is also applicable in man. Importantly, in the context of allergic disease, comparative studies on DCs from mucosal sites in humans and experimental animals suggest very similar functional characteristics.<sup>203</sup>

DCs commence seeding into peripheral tissues relatively early in gestation,<sup>204</sup> and at birth recognizable networks of these cells can be detected in a variety of tissues including epidermis,<sup>204–206</sup> intestinal mucosa<sup>207,208</sup> and the upper and lower respiratory tract.<sup>209,210</sup> The cells within these DC networks in perinatal tissues are typically present at lower densities and express lower levels of surface MHC class II relative to adults,<sup>205,206,210</sup> hinting at developmentally related variations in function phenotype. Recent murine studies have emphasized these differences. Notably, the phenomenon of neonatal tolerance in mice has recently been ascribed to the relative inability of neonatal DCs from central lymphoid organs to present Th1-inducing signals to T cells, leading to the preferential generation of Th2-biased immune responses.<sup>211</sup> Of particular relevance to studies on susceptibility to infectious and allergic diseases in infancy, our group has demonstrated that in the rat the airway mucosal DC compartment develops very slowly postnatally, not attaining adult-equivalent levels of tissue density, MHC class II



expression or capacity to respond to local inflammatory stimuli until after biologic weaning.<sup>210,212</sup>

Data based initially on immunohistochemical studies of autopsy tissues<sup>213,214</sup> and subsequently verified by airway biopsy studies<sup>215</sup> suggest that the kinetics of postnatal maturation of airway DC networks in humans may be comparably slow.

Reports suggest that the numbers of circulating HLA-DR<sup>+</sup> plasmacytoid and myeloid DCs are reduced at birth relative to adults,<sup>216,217</sup> with mDCs showing diminished APC activity.<sup>218,219</sup> Additionally, analysis of cord blood monocyte-derived DC functions indicates diminished expression of HLA-DR, CD80 and CD40 and attenuated production of IL-12p35 in response to stimuli such as LPS, poly(I:C) and CD40 ligation.<sup>220</sup> However, studies using human CD8<sup>+</sup> T cell clones to compare the ability of neonatal and adult DCs to present and process antigen using the MHC class I pathway found that neonatal DCs were not defective in their ability to perform these functions.<sup>221</sup> Studies have shown that synergistic stimulation of neonatal DCs by ligands for multiple TLRs is required for efficient differentiation, signaling and T cell priming; membrane-associated TLR4 and intracellular TLR3 were found to act in synergy with endosomal TLR4 to induce functional maturation of neonatal DCs.<sup>222</sup> Interestingly, cord blood monocyte-derived DCs have also been shown to express higher levels of IL-27 following TLR stimulation, which may compensate for the diminished ability of neonatal DCs to produce IL-12.<sup>223</sup>

## Granulocyte Populations

Eosinophils, mast cells and basophils play key roles in the pathogenesis of allergic disease, performing important functions in relation to host resistance to certain pathogens, and are thus relevant to this discussion. In particular, hyperreactivity within this granulocyte compartment, exemplified by exaggerated airway eosinophil responses to viral infections as highlighted in recent studies on RSV,<sup>224,225</sup> is widely considered a harbinger of the early stages of asthma pathogenesis in children.

Eosinophilia in the first year of life has been linked to enhanced risk for later development of atopic diseases in a range of studies but few direct mechanistic data are available. Several earlier observations are suggestive of developmentally related problems in eosinophil trafficking in early life; inflammatory exudates in neonates frequently contain elevated numbers of eosinophils,<sup>226–228</sup> and eosinophilia is common in premature infants.<sup>229,230</sup> The mechanisms underlying these developmental variations in eosinophil function are unclear, but some evidence suggests a role for integrin expression involving Mac-1<sup>231</sup> and L-selectin.<sup>232</sup> Developmental defects in this compartment may additionally be more frequent in the offspring of atopic mothers<sup>233,234</sup> and may thus be part of the suite of mechanisms that mediate genetically determined high risk for allergic disease.

Adult mucosal tissues contain discrete populations of mucosal mast cells (MMC) and connective tissue mast cells (CTMCs), respectively, within epithelia and underlying lamina propria. No direct information is available on the ontogeny of these mast cells (MCs) in human tissues, but indirect evidence suggests that they seed into gut tissues during infancy in response to local inflammatory stimulation.<sup>235</sup> Our group has examined the kinetics of postnatal development of MCs in the rat respiratory tract, and has reported that both MMC and CTMC populations develop slowly between birth and

weaning.<sup>236</sup> MC-derived proteases appear transiently in serum around the time of weaning in the rat, suggesting that the immature MC populations may be unstable or are undergoing local stimulation at this time,<sup>237</sup> and a similar transient peak of MC tryptase is observed in human serum during infancy.<sup>238</sup>

Direct functional studies on MCs from immature subjects are lacking. However, a 2001 report employed oligonucleotide microarray technology to examine IL-4-induced gene expression in cultured MCs derived from cord blood versus adult peripheral blood; the results indicate that expression of FcεR1α is 10-fold higher in adult-derived MCs.<sup>239</sup> This suggests that during infancy the capacity to express IgE-mediated immunity may be restricted, but confirmation of this possibility must await further detailed studies.

## Postnatal Maturation of Immune Functions and Allergic Sensitization

Studies from a number of groups have highlighted the importance of the early postnatal period in relation to the development of long-lasting response patterns to environmental allergens. In particular, it is becoming clear that initial priming of the naïve immune system typically occurs before weaning and may consolidate into stable immunologic memory before the end of the preschool years. Given that the underlying immunologic processes involve coordinated operation of the full gamut of innate and adaptive immune mechanisms, issues relating to developmentally determined functional competence during this life phase may be predicted to be of major importance.

In relation to initial priming of the T cell system against allergens, reports from numerous groups indicate the presence of T cells responsive to food and inhalant allergens in cord blood.<sup>240–244</sup> Cloning of these cells and subsequent DNA genotyping indicated fetal as opposed to maternal origin,<sup>245</sup> and the array of cytokines produced *in vitro* in their responses is dominated by Th2 cytokines, although IFN-γ is also observed, suggestive of a Th0-like pattern.<sup>245</sup> The issue of how initial priming of these cells occurs remains to be resolved. It is possible that transplacental transport of allergen, perhaps conjugated with maternal IgG, may be responsible, and some indirect evidence based on *in vitro* perfusion studies has been published to support this notion.<sup>246</sup> Moreover, the use of sensitive microassays has detected the presence of low levels of allergen-specific (particularly food allergen) IgE antibodies in cord blood which are unrelated to maternal antibody profiles, arguing against cross-contamination,<sup>29,30</sup> though this has been disputed.<sup>247</sup> Furthermore, prospective tracking of the postnatal appearance of aeroallergen-specific IgE antibody, and corresponding allergen-specific Th memory, shows strong concordance between these phenomena, commencing some time (depending on the specificity) between birth and age 6 months.<sup>248</sup> Alternatively, initial priming of T helper cells that drive production of these neonatal antibody responses may be against cross-reacting antigens as opposed to native allergen, and the uncertain relationship between maternal allergen exposure and newborn T cell reactivity is consistent with this view.<sup>249,250</sup> The T cell epitope map of the typical cord blood T cell response to ovalbumin (OVA), involving multiple regions of the OVA molecule,<sup>251</sup> suggests major qualitative differences relative to conventional adult T cell responses.

Regardless of how initial T cell responses are primed, it is clear that direct exposure to environmental allergens during infancy drives the early responses down one of two alternate pathways. In the majority of (nonatopic) subjects, the Th2 cytokine component of these early responses progressively diminishes, and by age 5 years *in vitro* T cell responses to allergens comprise a combination of low-level IFN- $\gamma$  and IL-10 production.<sup>251–253</sup> In contrast, a subset of children develop positive skin prick test (SPT) reactivity to one or more allergens, and *in vitro* stimulation of PBMC with the latter elicits a mixed or Th0-like response pattern comprising IL-4, IL-5, IL-9, IL-10, IL-13 and IFN- $\gamma$ .<sup>253</sup> This latter pattern closely resembles that seen in the majority of adult atopic patients, and much more commonly develops in atopic family history positive (AFH<sup>+</sup>) children than in their AFH<sup>-</sup> counterparts.

It is increasingly debated whether it remains useful to describe these differing responses in human atopic and nonatopic patients within the framework of the murine Th1/Th2 paradigm, which was based upon the concept of reciprocal and/or antagonistic patterns of Th memory expression. In this context, studies from our group<sup>254,255</sup> indicate that reciprocal patterns of expression of the transcription factor GATA3, analogous to those that distinguish Th1 from Th2 polarized cell lines (with regard to down-regulation vs up-regulation, respectively, post stimulation), are reiterated during the allergen-specific recall responses of CD4<sup>+</sup> T cells from nonatopic versus atopic subjects. Moreover as noted above, hyperexpression of this Th2 master regulator is a feature of T cells in the infant period<sup>77</sup> during which allergen-specific Th memory priming is most commonly initiated.<sup>248</sup> This suggests that the Th1/Th2 model still provides a potentially useful framework for the study of allergic responses, despite the strong likelihood of significant interspecies differences.

The central issue in relation to understanding the initial phase of allergic sensitization in childhood concerns the molecular basis for genetic susceptibility to development of Th2-polarized memory against inhalant allergens, and the key to the resolution of this puzzle may lie in a more comprehensive understanding of the mechanisms that drive postnatal maturation of adaptive immune function. In this regard, we have reported earlier that genetic risk for atopy was associated with delayed postnatal maturation of Th cell function, in particular Th1 function, and that this may increase risk for consolidating Th2-polarized memory against allergens during childhood. The evidence originally presented was based on decreased peripheral blood T cell cloning frequency and diminished IFN- $\gamma$  production by T cell clones in AFH<sup>+</sup> infants relative to their AFH<sup>-</sup> counterparts,<sup>89</sup> and these findings have been substantiated in several independent laboratories employing bulk culture studies with neonatal PBMC.<sup>256–261</sup>

We have proposed that this phenomenon may derive from inappropriate postnatal persistence of one or more of the mechanisms responsible for selective damping of T cell function, in particular that relating to Th1 immunity, during fetal life.<sup>262</sup> A possible contributor may be reduced expression of protein kinase C (PKC)  $\zeta$  in immature T cells, which is associated with prolongation of Th2 polarization, particularly in infants of allergic mothers.<sup>263</sup> Alternatively, given that the postnatal maturation of adaptive immunity is essentially driven by microbial signals from the outside environment,<sup>262,264,265</sup> one or more deficiencies in relevant receptors or downstream signaling pathways in microbial sensing cells within the adaptive immune system<sup>266</sup>

may retard this process. Genetic variations described in CD14 may be an example,<sup>267,268</sup> and similar variants in one or more of the TLR genes constitute additional likely candidates. These possibilities are of particular interest in light of reports that environmental exposure to airborne bacterial lipopolysaccharide in childhood may be protective against Th2-mediated sensitization to inhalant allergens.<sup>269,270</sup> European 'farmer-mother' studies have demonstrated that the combination of prenatal and postnatal exposure to inhaled and ingested microbial breakdown products is associated with strong protective effects against development of allergic diseases during early childhood.<sup>271</sup> A range of immune-associated mechanisms may contribute to these effects including modulation of TLR function initially in decidual tissue at the fetomaternal interface<sup>272,273</sup> and subsequently within the developing innate immune system of the offspring.<sup>274,275</sup> These exposures appear to stimulate the postnatal development of regulatory T cell function,<sup>276,277</sup> which has previously been identified as deficient in children at high risk of development of allergic diseases.<sup>39,278,279</sup> It is pertinent to note that these exposures have also been observed to enhance postnatal maturation of IFN- $\gamma$ -producing capacity,<sup>280</sup> a lack of which has been identified as a risk factor for allergy by our group and others. Longitudinal studies have suggested that Th1 deficiency may be transient and reversible, such that by 18 months of age Th1 function in children with atopic family history is equivalent to or greater than that in children without atopic family history.<sup>281</sup> We found in studies focussing on CBMC from AFH<sup>+</sup> children that early development of sensitization within this low-IFN- $\gamma$ -producing group is maximal among those who later show the highest IFN- $\gamma$  responses, suggesting a potentially dualistic role for IFN- $\gamma$  in atopy pathogenesis.<sup>282</sup> This conclusion is reinforced by the results of other studies in older (school age) children that suggest a positive role for IFN- $\gamma$  in airway symptomatology in atopics.<sup>283,284</sup> It is also feasible that IL-17<sup>285</sup> and TNF- $\alpha$ <sup>286</sup> responses may play a similar dualistic role in disease pathogenesis.

Further research is required to elucidate the complex regulatory mechanisms that govern generation of different patterns of allergen-specific Th memory during childhood. However, it is also becoming clear that an additional, and related, set of complexities needs to be considered. It is now evident that only a subset of atopic patients progress to development of severe persistent allergic diseases, in particular atopic asthma,<sup>287</sup> and it is likely that these subjects suffer additional and/or particularly intense inflammatory insults to target tissues. In this context, epidemiologic evidence suggests that risk for development of persistent asthma is most marked in children who display early allergic sensitization to inhalants<sup>288,289</sup> and who develop severe wheezing and lower respiratory tract infections during infancy.<sup>289–291</sup> This has given rise to the suggestion that development of the airways remodeling characteristic of chronic asthma<sup>292</sup> may, in many circumstances, be the long-term result of inflammation-induced changes in lung and airway differentiation during critical stages of early growth during childhood. Resistance to respiratory infections is also mediated by the same Th1 mechanisms identified as attenuated in children at risk of atopy,<sup>293</sup> suggesting that the same set of genetic mechanisms may be responsible for airways inflammation induced via the viral infection and atopic pathways in children at high risk of asthma (Box 6-2).

In this regard, a rapidly emerging area of interest relates to the role of vitamin D and resistance to infections and allergic

**BOX 6-2 KEY CONCEPTS****ROLE OF IMMUNE DEVELOPMENTAL FACTORS ON ALLERGIC RESPONSE**

- Dendritic cells (DCs) are the most potent antigen-presenting cells for priming naïve T cells against antigens encountered at low concentrations
- Neonatal DCs present weak Th1-inducing signals to T cells, leading to preferential generation of Th2 immune responses
- Slow postnatal maturation of IFN- $\gamma$  production capacity is linked to genetic risk for atopy
- Maturation of adaptive immunity is driven by microbial signals. Microflora in the gut, nasopharynx and lower airways are likely to contribute to these signals; the demonstration of a unique placental microbiome raises the question of whether this process could begin *in utero*
- A deficiency in microbial receptors (e.g. CD14, Toll receptors) or downstream signaling pathways may prevent the development of polarized Th1 responses
- Atopy may be associated with reduced diversity of commensal bacteria in early life
- Appropriate levels of vitamin D during immune development may be important to boost innate immune defenses against infection and to promote tolerance versus sensitization to allergens. An optimal vitamin D range for immune function has not been defined and could vary between individuals due to genotype-vitamin D interactions

diseases during childhood. Vitamin D is a potent immunomodulator; the active form (1,25(OH) $_2$ -vitamin D) complexes with its receptor in most known cell types, including immune cells, to initiate transcription of many genes.<sup>294</sup> Vitamin D induces epithelial and immune cells to produce antimicrobial peptides such as cathelicidin and defensin, which mediate killing of viruses and bacteria.<sup>295</sup> This mechanism is active at birth,<sup>296</sup> and low vitamin D at birth has been associated with increased respiratory infections in early life.<sup>297</sup> Vitamin D also promotes immune tolerance to allergens by up-regulating regulatory T cells<sup>298</sup> and suppressing IgE production.<sup>299</sup> A positive correlation has been observed between vitamin D and IL-10 levels in cord blood,<sup>300</sup> though another study found no associations between vitamin D and immune cell populations in cord blood.<sup>301</sup> Supplementation of pregnant mothers with vitamin D has been associated with increased production of tolerogenic

antigen-presenting cells in cord blood, identified by expression of ILT3 and ILT4 transcripts.<sup>302</sup>

The question of whether insufficient vitamin D during immune development can predispose children to allergy and asthma is a hot topic, and one that is currently unresolved as cohort studies have yielded conflicting results.<sup>303,304</sup> While this may in part be explained by inconsistencies in vitamin D measurement, heterogeneity between cohort populations is likely to be an important factor given that some associations between vitamin D and clinical outcomes are modified by specific genotypes.

An additional variable that merits more detailed research in this context is the role of airway DC populations. In the adult, these cells regulate the Th1/Th2 balance in immune responses to airborne antigens<sup>305</sup> and also mediate primary and secondary immunity to viral pathogens.<sup>199</sup> However, airway DC networks develop very slowly postnatally, apparently 'driven' by exposure to inhaled airborne irritants<sup>162</sup> including bacterial lipopolysaccharides,<sup>306,307</sup> and also by viral infections.<sup>215</sup> Hence the rate at which this key cell population gains competence to respond to maturation-inducing stimuli and then to orchestrate appropriately balanced T cell responses against viral pathogens, allergens and also bacterial pathogens within the nasopharyngeal microbiome<sup>308</sup> may be a key determinant of overall susceptibility to allergic disease. Variations in the genes that govern the functions of these cells in early life are thus likely to be of major importance in the etiology of a variety of disease processes, in particular atopic asthma and related syndromes.

**Conclusions**

Only a subset of patients with atopy develop more severe allergic diseases, and the ability to identify these patients early, and to choose treatment strategies accordingly, could potentially improve patient outcome. A variety of independent studies suggest that prospective evaluation of blood IgE levels, particularly in early childhood, may significantly aid in early identification of at-risk subjects.<sup>309</sup>

The complete reference list can be found on the companion Expert Consult website at <http://www.expertconsult.inkling.com>.

**KEY REFERENCES**

- Rowe J, Kusel M, Holt BJ, Suriyaarachchi D, Serralha M, Hollams E, et al. Prenatal versus postnatal sensitization to environmental allergens in a high-risk birth cohort. *J Allergy Clin Immunol* 2007;119:1164–73.
- Holt PG, Clough JB, Holt BJ, Baron-Hay MJ, Rose AH, Robinson BWS, et al. Genetic 'risk' for atopy is associated with delayed postnatal maturation of T-cell competence. *Clin Exp Allergy* 1992;22:1093–9.
- Upham JW, Lee PT, Holt BJ, Heaton T, Prescott SL, Sharp MJ, et al. Development of interleukin-12-producing capacity throughout childhood. *Infect Immun* 2002;70:6583–8.
- Thornton CA, Upham JW, Wikstrom ME, Holt BJ, White GP, Sharp MJ, et al. Functional maturation of CD4<sup>+</sup>CD25<sup>+</sup>CTLA4<sup>+</sup>CD45RA<sup>+</sup> T regulatory cells in human neonatal T cell responses to environmental antigens/allergens. *J Immunol* 2004;173:3084–92.
- Zhang G, Rowe J, Kusel M, Bosco A, McKenna K, de Klerk N, et al. Interleukin-10/interleukin-5 responses at birth predict risk for respiratory infections in children with atopic family history. *Am J Respir Crit Care Med* 2009;179:205–11.
- Nelson DJ, Holt PG. Defective regional immunity in the respiratory tract of neonates is attributable to hyporesponsiveness of local dendritic cells to activation signals. *J Immunol* 1995;155:3517–24.
- Prescott SL, Macaubas C, Smallcombe T, Holt BJ, Sly PD, Holt PG. Development of allergen-specific T-cell memory in atopic and normal children. *Lancet* 1999;353:196–200.
- Tang MLK, Kemp AS, Thorburn J, Hill DJ. Reduced interferon-gamma secretion in neonates and subsequent atopy. *Lancet* 1994;344:983–6.
- Roponen M, Hyvarinen A, Hirvonen MR, Keski-Nisula L, Pekkanen J. Change in IFN-gamma-producing capacity in early life and exposure to environmental microbes. *J Allergy Clin Immunol* 2005;116:1048–52.
- Holt PG, Strickland DH, Hales BJ, Sly PD. Defective respiratory tract immune surveillance in asthma. *Chest* 2014;145:370–8.



## REFERENCES

- Lambropoulou M, Tamiolakis D, Venizelos I, Alexiadis G, Anastasopoulos G, Limberis V, et al. Induction of hepatic haematopoiesis with fibronectin expression by EMT stromal cells during the second trimester of development. *Clin Exp Med* 2007;7:115–21.
- Compana D, Janosy G, Coustan-Smith E, Amlot PL, Tian W-T, Ip S, et al. The expression of T cell receptor-associated proteins during T cell ontogeny in man. *J Immunol* 1989;142:57–66.
- Haynes BF, Martin ME, Kay HH, Kurtzberg J. Early events in human T cell ontogeny. Phenotypic characterization and immunohistologic localization of T cell precursors in early human fetal tissues. *J Exp Med* 1988;168:1061–80.
- Haynes BF, Singer KH, Denning SM, Martin ME. Analysis of expression of CD2, CD3, and T cell antigen receptor molecules during early human fetal thymic development. *J Immunol* 1988;141:3776–84.
- Migliaccio G, Migliaccio AR, Petti S, Mavilio F, Russo G, Lazzaro D, et al. Human embryonic hemopoiesis. Kinetics of progenitors and precursors underlying the yolk sac–liver transition. *J Clin Invest* 1986;78:51–60.
- Asma GEM, Van Den Bergh RL, Vossen JM. Use of monoclonal antibodies in a study of the development of T lymphocytes in the human fetus. *Clin Exp Immunol* 1983;53:429–36.
- Royo C, Touraine J-L, De Bouteiller O. Ontogeny of T lymphocyte differentiation in the human fetus: acquisition of phenotype and functions. *Thymus* 1987;10:57–73.
- Timens W, Rozeboom T, Poppema S. Fetal and neonatal development of human spleen: an immunohistological study. *Immunology* 1987;60:603–9.
- Markgraf R, von Gaudecker B, Muller-Hermelink H-K. The development of the human lymph node. *Cell Tissue Res* 1982;225:387–413.
- Namikawa R, Mizuno T, Matsuoka H, Fukami H, Ueda R, Itoh G, et al. Ontogenic development of T and B cells and non-lymphoid cells in the white pulp of human spleen. *Immunology* 1986;57:61–9.
- Vellguth S, von Gaudecker B, Muller-Hermelink H-K. The development of the human spleen. Ultrastructural studies in fetuses from the 14th to 24th week of gestation. *Cell Tissue Res* 1985;242:579–92.
- Fichtelius KE. The gut epithelium – a first level lymphoid organ? *Exp Cell Res* 1968;49:87–104.
- Spencer J, MacDonald TT, Finn T, Isaacson PG. The development of gut associated lymphoid tissue in the terminal ileum of fetal human intestine. *Clin Exp Immunol* 1986;3:536–43.
- Latthe M, Terry L, MacDonald TT. High frequency of CD8 alpha alpha homodimer-bearing T cells in human fetal intestine. *Eur J Immunol* 1994;24:1703–5.
- Howie D, Spencer J, DeLord D, Pitzalis C, Wathen NC, Dogan A, et al. Extrathymic T cell differentiation in the human intestine early in life. *J Immunol* 1998;161:5862–72.
- McVay LD, Jaswal SS, Kennedy C, Hayday A, Carding SR. The generation of human gamma delta T cell repertoires during fetal development. *J Immunol* 1998;160:5851–60.
- Wucherpfennig KW, Liao YJ, Prendergast M, Hafler DA, Strominger JL. Human fetal liver gamma/delta T cells predominantly use unusual rearrangements of the T cell receptor delta and gamma loci expressed on both CD4+ CD8– and CD4– CD8– gamma/delta T cells. *J Exp Med* 1993;177:425–32.
- Stites DP, Carr MC, Fudenberg HH. Ontogeny of cellular immunity in the human fetus. Development of responses to phytohaemagglutinin and to allogeneic cells. *Cell Immunol* 1974;11:257–71.
- Aase JM, Noren GR, Reddy DV, St Geme JW. Mumps-virus infection in pregnant women and the immunologic response of their offspring. *N Engl J Med* 1972;286:1379–82.
- Sanjeevi CB, Vivekanandan S, Narayanan PR. Fetal response to maternal ascariasis as evidenced by anti-*Ascaris lumbricoides* IgM antibodies in the cord blood. *Acta Paediatr Scand* 1991;80:1134–8.
- Fievet N, Ringwald P, Bickii J. Malaria cellular immune responses in neonates from Cameroon. *Parasite Immunol* 1996;18:483–90.
- Novato-Silva E, Gazzinelli G, Colley DG. Immune responses during human schistosomiasis mansoni. XVIII. Immunologic status of pregnant women and their neonates. *Scand J Immunol* 1992;35:429–37.
- King CL, Malhotra I, Mungai P, Wamachi A, Kioko J, Ouma JH, et al. B cell sensitization to helminthic infection develops in utero in humans. *J Immunol* 1998;160:3578–84.
- McLeod R, Mack DG, Boyer K, Mets M, Roizen N, Swisher C, et al. Phenotypes and functions of lymphocytes in congenital toxoplasmosis. *J Lab Clin Med* 1990;116:623–35.
- Zhang X, Mozeleski B, Lemoine S, Deriaud E, Lim A, Zhivaki D, et al. CD4 T cells with effector memory phenotype and function develop in the sterile environment of the fetus. *Sci Transl Med* 2014;6:238ra272.
- Gill TJ, Repetti CE, Metlay LA. Transplacental immunisation of the human fetus to tetanus by immunisation of the mother. *J Clin Invest* 1983;72:987–96.
- Rastogi D, Wang C, Mao X, Lendor C, Rothman PB, Miller RL. Antigen-specific immune responses to influenza vaccine in utero. *J Clin Invest* 2007;117:1637–46.
- Holt PG. Primary allergic sensitization to environmental antigens: perinatal T-cell priming as a determinant of responder phenotype in adulthood. *J Exp Med* 1996;183:1297–301.
- Pfefferle PI, Sel S, Ege MJ, Buchele G, Blumer N, Krauss-Etschmann S, et al. Cord blood allergen-specific IgE is associated with reduced IFN-gamma production by cord blood cells: the Protection against Allergy-Study in Rural Environments (PASTURE) Study. *J Allergy Clin Immunol* 2008;122:711–16.
- Kamemura N, Tada H, Shimojo N, Morita Y, Kohno Y, Ichioka T, et al. Intrauterine sensitization of allergen-specific IgE analyzed by a highly sensitive new allergen microarray. *J Allergy Clin Immunol* 2012;130:113–21 e112.
- Rowe J, Kusel M, Holt BJ, Suriyaarachchi D, Serralha M, Hollams E, et al. Prenatal versus postnatal sensitization to environmental allergens in a high-risk birth cohort. *J Allergy Clin Immunol* 2007;119:1164–73.
- Holt PG. Prenatal versus postnatal priming of allergen specific immunologic memory: The debate continues. *J Allergy Clin Immunol* 2008;122:717–18.
- Aagaard K, Ma J, Antony KM, Ganu R, Petrosino J, Versalovic J. The placenta harbors a unique microbiome. *Sci Transl Med* 2014;6:237ra265.
- Gasparoni A, Ciardelli L, Avanzini A, Castellazzi AM, Carini R, Rondini G, et al. Age-related changes in intracellular TH1/TH2 cytokine production, immunoproliferative T lymphocyte response and natural killer cell activity in newborns, children and adults. *Biol Neonate* 2003;84:297–303.
- Perez A, Gurbindo MD, Resino S, Aguaron A, Munoz-Fernandez MA. NK cell increase in neonates from the preterm to the full-term period of gestation. *Neonatology* 2007;92:158–63.
- Byrne JA, Stankovic AK, Cooper MD. A novel subpopulation of primed T cells in the human fetus. *J Immunol* 1994;152:3098–106.
- Michaelsson J, Mold JE, McCune JM, Nixon DF. Regulation of T cell responses in the developing human fetus. *J Immunol* 2006;176:5741–8.
- Yu P, Haymaker CL, Divekar RD, Ellis JS, Hardaway J, Jain R, et al. Fetal exposure to high-avidity TCR ligand enhances expansion of peripheral T regulatory cells. *J Immunol* 2008;181:73–80.
- Schaub B, Liu J, Hoppler S, Haug S, Sattler C, Lluís A, et al. Impairment of T-regulatory cells in cord blood of atopic mothers. *J Allergy Clin Immunol* 2008;121:1491–9, 1499 e1–13.
- Wegmann TG, Lin H, Guilbert L, Mosmann TR. Bidirectional cytokine interactions in the maternal-fetal relationship: is successful pregnancy a Th2 phenomenon? *Immunol Today* 1993;14:353–6.
- Price JO, Elias S, Wachtel SS, Klinger K, Dockter M, Tharapel A, et al. Prenatal diagnosis with fetal cells isolated from maternal blood by multiparameter flow cytometry. *Am J Obstet Gynecol* 1991;165(6 Pt 1):1731–7.
- Bianchi DW, Zickwolf GK, Yih MC, Flint A, Geifman OH, Erikson MS, et al. Erythroid specific antibodies enhance detection of fetal nucleated erythrocytes in maternal blood. *Prenat Diagn* 1993;13:293.
- Herzenberg LA, Bianchi DW, Schroder J, Cann HM, Iverson MG. Fetal cells in the blood of pregnant women: detection and enrichment by fluorescence-activated cell sorting. *Proc Natl Acad Sci U S A* 1979;76:1453.
- Lo Y-MD, Wainscoat JS, Gillmer MDG, Patel P, Sampietro M, Fleming KA. Prenatal sex determination by DNA amplification from maternal peripheral blood. *Lancet* 1989;2:1363.
- Wachtel S, Elias S, Price J, Wachtel G, Phillips O, Shulman L, et al. Fetal cells in the maternal circulation: isolation by multiparameter flow cytometry and confirmation by polymerase chain reaction. *Hum Reprod* 1991;6:1466.
- Bonney EA, Matzinger P. The maternal immune system's interaction with circulating fetal cells. *J Immunol* 1997;158:40–7.
- Amodio G, Mugione A, Sanchez AM, Vigano P, Candiani M, Somigliana E, et al. HLA-G expressing DC-10 and CD4(+) T cells accumulate in human decidua during pregnancy. *Hum Immunol* 2013;74:406–11.
- Houser BL. Decidual macrophages and their roles at the maternal-fetal interface. *Yale J Biol Med* 2012;85:105–18.
- Munn DH, Zhou M, Attwood JT, Bondarev I, Conway SJ, Marshall B, et al. Prevention of allogeneic fetal rejection by tryptophan catabolism. *Science* 1998;281:1191–3.



50. Roth I, Corry DB, Locksley RM, Abrams JS, Litton MJ, Fisher SJ. Human placental cytotrophoblasts produce the immunosuppressive cytokine interleukin 10. *J Exp Med* 1996;184:539–48.
51. Kzhyshkowska J, Gratchev A, Schmuttmaier C, Brundiers H, Krusel L, Mamidi S, et al. Alternatively activated macrophages regulate extracellular levels of the hormone placental lactogen via receptor-mediated uptake and transcytosis. *J Immunol* 2008;180:3028–37.
52. Guller S, LaChapelle L. The role of placental Fas ligand in maintaining immune privilege at maternal-fetal interface. *Semin Reprod Endocrinol* 1999;17:39–44.
53. Hammer A, Blaschitz A, Daxbock C, Walcher W, Dohr G. Gas and Fas-ligand are expressed in the uteroplacental unit of first-trimester pregnancy. *Am J Reprod Immunol* 1999;41:41–51.
54. Fu B, Li X, Sun R, Tong X, Ling B, Tian Z, et al. Natural killer cells promote immune tolerance by regulating inflammatory TH17 cells at the human maternal-fetal interface. *Proc Natl Acad Sci U S A* 2013;110:E231–40.
55. Tilburgs T, Roelen DL, van der Mast BJ, de Groot-Swings GM, Kleijburg C, Scherjon SA, et al. Evidence for a selective migration of fetus-specific CD4<sup>+</sup>CD25<sup>+</sup> regulatory T cells from the peripheral blood to the decidua in human pregnancy. *J Immunol* 2008;180:5737–45.
56. Ashkar AA, Di Santo JP, Croy BA. Interferon gamma contributes to initiation of uterine vascular modification, decidual integrity, and uterine natural killer cell maturation during normal murine pregnancy. *J Exp Med* 2000;192:259–69.
57. Krishnan L, Guilbert LJ, Russell AS, Wegmann TG, Mosmann TR, Belosevic M. Pregnancy impairs resistance of C57BL/6 mice to *Leishmania major* infection and causes decreased antigen-specific IFN- $\gamma$  responses and increased production of T helper 2 cytokines. *J Immunol* 1996;156:644–52.
58. Krishnan L, Guilbert LJ, Wegmann TG, Belosevic M, Mosmann TR. T helper 1 response against *Leishmania major* in pregnant C57BL/6 mice increases implantation failure and fetal resorptions. *J Immunol* 1996;156:653–62.
59. Hilkens CM, Vermeulen H, Joost van Neerven RJ, Snijdwint FGM, Wierenga EA, Kapsenberg ML. Differential modulation of T helper type 1 (Th1) and T helper type 2 (Th2) cytokine secretion by prostaglandin E<sub>2</sub> critically depends on interleukin-2. *Eur J Immunol* 1995;25:59–63.
60. Piccinni M-P, Giudizi M-G, Biagiotti R, Beloni L, Giannarini L, Sampognaro S, et al. Progesterone favours the development of human T helper cells producing Th2-type cytokines and promotes both IL-4 production and membrane CD30 expression in established Th1 cell clones. *J Immunol* 1995;155:128–33.
61. Szekeres-Bartho J, Faust Z, Varga P, Szereday L, Kelemen K. The immunological pregnancy protective effect of progesterone is manifested via controlling cytokine production. *Am J Reprod Immunol* 1996;35:348–51.
62. Szekeres-Bartho J, Wegmann TG. A progesterone-dependent immunomodulatory protein alters the Th1/Th2 balance. *J Reprod Immunol* 1996;31:81–95.
63. Giannoni E, Guignard L, Knaup Reymond M, Perreau M, Roth-Kleiner M, Calandra T, et al. Estradiol and progesterone strongly inhibit the innate immune response of mononuclear cells in newborns. *Infect Immun* 2011;79:2690–8.
64. Della Bella S, Giannelli S, Cozzi V, Signorelli V, Cappelletti M, Cetin I, et al. Incomplete activation of peripheral blood dendritic cells during healthy human pregnancy. *Clin Exp Immunol* 2011;164:180–92.
65. Miller ME. Phagocyte function in the neonate: selected aspects. *Pediatrics* 1979;64(5 Pt 2 Suppl):709–12.
66. Burchett SK, Corey L, Mohan KM, Westall J, Ashley R, Wilson CB. Diminished interferon- $\gamma$  and lymphocyte proliferation in neonatal and postpartum primary herpes simplex virus infection. *J Infect Dis* 1992;165:813–18.
67. Siegrist CA. Vaccination in the neonatal period and early infancy. *Int Rev Immunol* 2000;19:195–219.
68. Wilson CB. Immunologic basis for increased susceptibility of the neonate to infection. *J Pediatr* 1986;108:1–12.
69. Friedmann PS. Cell-mediated immunological reactivity in neonates and infants with congenital syphilis. *Clin Exp Immunol* 1977;30:271–6.
70. Hayward AR, Herberger M, Saunders D. Herpes simplex virus-stimulated  $\gamma$ -interferon production by newborn mononuclear cells. *Pediatr Res* 1986;20:398–400.
71. Starr SE, Tolpin MD, Friedman HM, Paucker K, Plotkin SA. Impaired cellular immunity to cytomegalovirus in congenitally infected children and their mothers. *J Infect Dis* 1979;140:500–5.
72. Hayward AR, Groothuis J. Development of T cells with memory phenotype in infancy. *Adv Exp Med Biol* 1991;310:71–6.
73. Comans-Bitter WM, de Groot R, van den Beemd R, Neijens HJ, Hop WCJ, Groeneveld K, et al. Immunophenotyping of blood lymphocytes in childhood. Reference values for lymphocyte subpopulations. *J Pediatr* 1997;130:388–93.
74. de Vries E, de Bruin-Versteeg S, Comans-Bitter WM, de Groot R, Hop WCJ, Boerma GJM, et al. Longitudinal survey of lymphocyte subpopulations in the first year of life. *Pediatr Res* 2000;47(4 Pt 1):528–37.
75. Griffiths-Chu S, Patterson JAK, Berger CL, Edelson RL, Chu AC. Characterization of immature T cell subpopulations in neonatal blood. *Blood* 1984;64:296–300.
76. Maccario R, Nespoli L, Mingrat G, Vitiello A, Ugazio AG, Burgio GR. Lymphocyte subpopulations in the neonate: identification of an immature subset of OKT8-positive, OKT3-negative cells. *J Immunol* 1983;130:1129–31.
77. Hebel K, Weinert S, Kuroпка B, Knolle J, Kosak B, Jorch G, et al. CD4<sup>+</sup> T cells from human neonates and infants are poised spontaneously to run a nonclassical IL-4 program. *J Immunol* 2014;192:5160–70.
78. Clement LT, Vink PE, Bradley GE. Novel immunoregulatory functions of phenotypically distinct subpopulations of CD4<sup>+</sup> cells in the human neonate. *J Immunol* 1990;145:102–8.
79. Hassan J, Reen DJ. Human recent thymic emigrants – identification, expansion and survival characteristics. *J Immunol* 2001;167:1970–6.
80. Hassan J, Reen DJ. IL-7 promotes the survival and maturation but not differentiation of human post-thymic CD4<sup>+</sup> T-cells. *Eur J Immunol* 1998;28:3057–65.
81. Calado RT, Garcia AB, Falcao RP. Age-related changes of immunophenotypically immature lymphocytes in normal human peripheral blood. *Cytometry* 1999;38:133–7.
82. Hannel T, Erkeller-Yuksel F, Lydyard P, Deney V, De Bruyere M. Developmental and maturational changes in human blood lymphocyte subpopulations. *Immunol Today* 1992;13:215–18.
83. Hassan J, Reen DJ. Neonatal CD4<sup>+</sup> CD45RA<sup>+</sup> T cells: precursors of adult CD4<sup>+</sup> CD45RA<sup>+</sup> T cells? *Res Immunol* 1993;144:87–92.
84. Bradley L, Bradley J, Ching D, Shiigi SM. Predominance of T cells that express CD45R in the CD4<sup>+</sup> helper/inducer lymphocyte subset of neonates. *Clin Immunol Immunopathol* 1989;51:426–35.
85. Gerli R, Bertotto A, Spinozzi F, Cernetti C, Grignani F, Rambotti P. Phenotypic dissection of cord blood immunoregulatory T-cell subsets by using a two-color immunofluorescence study. *Clin Immunol Immunopathol* 1986;40:429–35.
86. Hayward A, Lee J, Beverley PCL. Ontogeny of expression of UCHL1 antigen on TcR-1+ (CD4/8) and TcR delta+ T cells. *Eur J Immunol* 1989;19:771–3.
87. Kingsley G, Pitzalis C, Waugh A, Panayi G. Correlation of immunoregulatory function with cell phenotype in cord blood lymphocytes. *Clin Exp Immunol* 1988;73:40–5.
88. Sanders ME, Makgoba MW, Shaw S. Human naive and memory T cells; reinterpretation of helper-inducer and suppressor-inducer subsets. *Immunol Today* 1988;9:195–9.
89. Holt PG, Clough JB, Holt BJ, Baron-Hay MJ, Rose AH, Robinson BWS, et al. Genetic 'risk' for atopy is associated with delayed postnatal maturation of T-cell competence. *Clin Exp Allergy* 1992;22:1093–9.
90. Pirenne H, Aujard Y, Eljaafari A, Bourillon A, Oury JF, Le GS, et al. Comparison of T cell functional changes during childhood with the ontogeny of CDw29 and CD45RA expression on CD4<sup>+</sup> T cells. *Pediatr Res* 1992;32:1–6.
91. Stern DA, Hicks MJ, Martinez FD, Holberg CJ, Wright AL, Pinnas J, et al. Lymphocyte subpopulation number and function in infancy. *Dev Immunol* 1992;2:175–9.
92. Hassan J, Reen DJ. Reduced primary antigen-specific T-cell precursor frequencies in neonates is associated with deficient interleukin-2 production. *Immunology* 1996;87:604–8.
93. Hassan J, Reen DJ. Cord blood CD4<sup>+</sup> CD45RA<sup>+</sup> T cells achieve a lower magnitude of activation when compared with their adult counterparts. *Immunology* 1997;90:397–401.
94. Bertotto A, Gerli R, Lanfrancone L, Crupi S, Arcangeli C, Cernetti C, et al. Activation of cord T lymphocytes. II. Cellular and molecular analysis of the defective response induced by anti-CD3 monoclonal antibody. *Cell Immunol* 1990;127:247–59.
95. Gerli R, Agea E, Muscat C, Tognellini R, Fiorucci G, Spinozzi F, et al. Activation of cord T lymphocytes. III. Role of LFA-1/ICAM-1 and CD2/LFA-3 adhesion molecules in CD3-induced proliferative response. *Cell Immunol* 1993;148:32–47.
96. Hassan J, O'Neill S, O'Neill LAJ, Pattison U, Reen DJ. Signalling via CD28 of human naive neonatal T lymphocytes. *Clin Exp Immunol* 1995;102:192–8.
97. Early EM, Reen DJ. Antigen-independent responsiveness to interleukin-4 demonstrates

- differential regulation of newborn human T cells. *Eur J Immunol* 1996;26:2885–9.
98. Shu U, Demeure CE, Byun D-G, Podlaski F, Stern AS, Delespesse G. Interleukin 12 exerts a differential effect on the maturation of neonatal and adult human CD45RO<sup>+</sup> CD4 T cells. *J Clin Invest* 1994;94:1352–8.
  99. Zola H, Fusco M, Weedon H, MacArdle PJ, Ridings J, Robertson DM. Reduced expression of the interleukin-2-receptor  $\gamma$  chain on cord blood lymphocytes: relationship to functional immaturity of the neonatal immune response. *Immunology* 1996;87:86–91.
  100. Upham JW, Lee PT, Holt BJ, Heaton T, Prescott SL, Sharp MJ, et al. Development of interleukin-12-producing capacity throughout childhood. *Infect Immun* 2002;70:6583–8.
  101. Macardle PJ, Wheatland L, Zola H. Analysis of the cord blood T lymphocyte response to superantigen. *Hum Immunol* 1999;60:127–39.
  102. Takahashi N, Imanishi K, Nishida H, Uchiyama T. Evidence for immunologic immaturity of cord blood T cells. *J Immunol* 1995;155:5213–19.
  103. Porcu P, Gaddy J, Broxmeyer HE. Alloantigen-induced unresponsiveness in cord blood T lymphocytes is associated with defective activation of Ras. *Proc Natl Acad Sci U S A* 1998;95:4538–43.
  104. Miscia S, Di Baldassarre A, Sabatino G, Bonvini E, Rana RA, Vitale M, et al. Inefficient phospholipase C activation and reduced Lck expression characterize the signaling defect of umbilical cord T lymphocytes. *J Immunol* 1999;163:2416–24.
  105. Whisler RL, Newhouse YG, Grants IS, Hackshaw KV. Differential expression of the  $\alpha$ - and  $\beta$ - isoforms of protein kinase C in peripheral blood T and B cells from young and elderly adults. *Mech Ageing Dev* 1995;77:197–211.
  106. Sato K, Nagayama H, Takahasji TA. Aberrant CD3- and CD28-mediated signaling events in cord blood T cells are associated with dysfunctional regulation of Fas ligand-mediated cytotoxicity. *J Immunol* 1999;162:4464–71.
  107. Sato K, Kawasaki H, Nagayama H, Enomoto M, Morimoto C, Tadokoro K, et al. Chemokine receptor expressions and responsiveness of cord blood T cells. *J Immunol* 2001;166:1659–66.
  108. Crespo M, Martinez DG, Cerissi A, Rivera-Reyes B, Bernstein HB, Lederman MM, et al. Neonatal T-cell maturation and homing receptor responses to Toll-like receptor ligands differ from those of adult naive T cells: relationship to prematurity. *Pediatr Res* 2012;71:136–43.
  109. Andersson U, Bird AG, Britten S, Palacios R. Human and cellular immunity in humans studied at the cellular level from birth to two years. *Immunol Rev* 1981;57:5–19.
  110. Hayward AR. Development of lymphocyte responses in humans, the fetus and newborn. *Immunol Rev* 1981;57:43–61.
  111. Durandy A, De Saint Basile G, Lisowska-Grospierre B, Gauchat J-F, Forveille M, Kroczyk RA, et al. Undetectable CD40 ligand expression on T cells and low B cell responses to CD40 binding antagonists in human newborns. *J Immunol* 1995;154:1560–8.
  112. Fuleihan R, Ahern D, Geha RS. Decreased expression of the ligand for CD40 in newborn lymphocytes. *Eur J Immunol* 1994;24:1925–8.
  113. Splawski JB, Lipsky PE. Cytokine regulation of immunoglobulin secretion by neonatal lymphocytes. *J Clin Invest* 1991;88:967–77.
  114. Zola H, Fusco M, MacArdle PJ, Flego L, Robertson D. Expression of cytokine receptors by human cord blood lymphocytes: comparison with adult blood lymphocytes. *Pediatr Res* 1995;38:397–403.
  115. Lee SM, Suen Y, Chang L, Bruner V, Qian J, Indes J, et al. Decreased interleukin-12 (IL-12) from activated cord versus adult peripheral blood mononuclear cells and upregulation of interferon- $\gamma$ , natural killer, and lymphokine-activated killer activity by IL-12 in cord blood mononuclear cells. *Blood* 1996;88:945–54.
  116. Chheda S, Palkowetz KH, Garofalo R, Rassin DK, Goldman AS. Decreased interleukin-10 production by neonatal monocytes and T cells: relationship to decreased production and expression of tumor necrosis factor- $\alpha$  and its receptors. *Pediatr Res* 1996;40:475–83.
  117. Qian JX, Lee SM, Suen Y, Knoppel E, van de Ven C, Cairo MS. Decreased interleukin-15 from activated cord versus adult peripheral blood mononuclear cells and the effect of interleukin-15 in upregulating antitumor immune activity and cytokine production in cord blood. *Blood* 1997;90:3106–17.
  118. Scott ME, Kubin M, Kohl S. High level interleukin-12 production, but diminished interferon- $\gamma$  production, by cord blood mononuclear cells. *Pediatr Res* 1997;41(4 Pt 1):547–53.
  119. Kotiranta-Ainamo A, Rautonen J, Rautonen N. Interleukin-10 production by cord blood mononuclear cells. *Pediatr Res* 1997;41:110–13.
  120. Chalmers IMH, Janossy G, Contreras M, Navarrete C. Intracellular cytokine profile of cord and adult blood lymphocytes. *Blood* 1998;92:11–18.
  121. Adkins B. T-cell function in newborn mice and humans. *Immunol Today* 1999;20:330–5.
  122. Wilson CB, Westall J, Johnston L, Lewis DB, Dover SK, Apert AR. Decreased production of interferon gamma by human neonatal cells. Intrinsic and regulatory deficiencies. *J Clin Invest* 1986;77:860–7.
  123. Taylor S, Bryson YJ. Impaired production of gamma-interferon by newborn cells is due to a functionally immature macrophage. *J Immunol* 1985;134:1493–8.
  124. Lewis DB, Yu CC, Meyer J, English BK, Kahn SJ, Wilson CB. Cellular and molecular mechanisms for reduced interleukin 4 and interferon-gamma production by neonatal T cells. *J Clin Invest* 1991;87:194–202.
  125. Murphy SP, Tayade C, Ashkar AA, Hatta K, Zhang J, Croy BA. Interferon gamma in successful pregnancies. *Biol Reprod* 2009;80:848–59.
  126. White GP, Watt PM, Holt BJ, Holt PG. Differential patterns of methylation of the IFN- $\gamma$  promoter at CpG and non-CpG sites underlie differences in IFN- $\gamma$  gene expression between human neonatal and adult CD45RO<sup>+</sup> T-cells. *J Immunol* 2002;168:2820–7.
  127. White GP, Hollams EM, Yerkovich ST, Bosco A, Holt BJ, Bassami MR, et al. CpG methylation patterns in the IFN gamma promoter in naive T cells: Variations during Th1 and Th2 differentiation and between atopics and non-atopics. *Pediatr Allergy Immunol* 2006;17:557–64.
  128. Thornton CA, Upham JW, Wikstrom ME, Holt BJ, White GP, Sharp MJ, et al. Functional maturation of CD4<sup>+</sup>CD25<sup>+</sup>CTLA4<sup>+</sup>CD45RA<sup>+</sup> T regulatory cells in human neonatal T cell responses to environmental antigens/allergens. *J Immunol* 2004;173:3084–92.
  129. Mayer E, Bannert C, Gruber S, Klunker S, Spittler A, Akdis CA, et al. Cord blood derived CD4<sup>+</sup> CD25(high) T cells become functional regulatory T cells upon antigen encounter. *PLoS ONE* 2012;7:e29355.
  130. Schober L, Radnai D, Schmitt E, Mahnke K, Sohn C, Steinborn A. Term and preterm labor: decreased suppressive activity and changes in composition of the regulatory T-cell pool. *Immunol Cell Biol* 2012;90:935–44.
  131. Rabe H, Lundell AC, Andersson K, Adlerberth I, Wold AE, Rudin A. Higher proportions of circulating FOXP3<sup>+</sup> and CTLA-4<sup>+</sup> regulatory T cells are associated with lower fractions of memory CD4<sup>+</sup> T cells in infants. *J Leukoc Biol* 2011;90:1133–40.
  132. Correa-Rocha R, Perez A, Lorente R, Ferrando-Martinez S, Leal M, Gurbindo D, et al. Preterm neonates show marked leukopenia and lymphopenia that are associated with increased regulatory T-cell values and diminished IL-7. *Pediatr Res* 2012;71:590–7.
  133. Dirix V, Vermeulen F, Mascart F. Maturation of CD4<sup>+</sup> regulatory T lymphocytes and of cytokine secretions in infants born prematurely. *J Clin Immunol* 2013;33:1126–33.
  134. Luciano AA, Arbona-Ramirez IM, Ruiz R, Llorens-Bonilla BJ, Martinez-Lopez DG, Funderburg N, et al. Alterations in regulatory T cell subpopulations seen in preterm infants. *PLoS ONE* 2014;9:e95867.
  135. Mukhopadhyay D, Weaver L, Tobin R, Henderson S, Beeram M, Newell-Rogers MK, et al. Intrauterine growth restriction and prematurity influence regulatory T cell development in newborns. *J Pediatr Surg* 2014;49:727–32.
  136. Zhang G, Rowe J, Kusel M, Bosco A, McKenna K, de Klerk N, et al. Interleukin-10/interleukin-5 responses at birth predict risk for respiratory infections in children with atopic family history. *Am J Respir Crit Care Med* 2009;179:205–11.
  137. Frohlich A, Kisielow J, Schmitz I, Freigang S, Shamshiev AT, Weber J, et al. IL-21R on T cells is critical for sustained functionality and control of chronic viral infection. *Science* 2009;324:1576–80.
  138. Elsaesser H, Sauer K, Brooks DG. IL-21 is required to control chronic viral infection. *Science* 2009;324:1569–72.
  139. Yi JS, Du M, Zajac AJ. A vital role for interleukin-21 in the control of a chronic viral infection. *Science* 2009;324:1572–6.
  140. Malhotra I, Wamachi AN, Mungai PL, Mzungu E, Koech D, Muchiri E, et al. Fine specificity of neonatal lymphocytes to an abundant malaria blood-stage antigen: epitope mapping of Plasmodium falciparum MSP1(33). *J Immunol* 2008;180:3383–90.
  141. Schmidt-Weber CB, Akdis M, Akdis CA. TH17 cells in the big picture of immunology. *J Allergy Clin Immunol* 2007;120:247–54.
  142. Cosmi L, De Palma R, Santarlasci V, Maggi L, Capone M, Frosali F, et al. Human interleukin 17-producing cells originate from a CD161<sup>+</sup> CD4<sup>+</sup> T cell precursor. *J Exp Med* 2008;205:1903–16.
  143. Black A, Bhaumik S, Kirkman RL, Weaver CT, Randolph DA. Developmental regulation of Th17-cell capacity in human neonates. *Eur J Immunol* 2012;42:311–19.

144. Corbett NP, Blimkie D, Ho KC, Cai B, Sutherland DP, Kallos A, et al. Ontogeny of Toll-like receptor mediated cytokine responses of human blood mononuclear cells. *PLoS ONE* 2010;5:e15041.
145. Stoppelenburg AJ, de Roock S, Hennis MP, Bont L, Boes M. Elevated Th17 response in infants undergoing respiratory viral infection. *Am J Pathol* 2014;184:1274–9.
146. Levy O. Innate immunity of the newborn: basic mechanisms and clinical correlates. *Nat Rev Immunol* 2007;7:379–90.
147. Sumino K, Tucker J, Shahab M, Jaffee KF, Visness CM, Gern JE, et al. Antiviral IFN-gamma responses of monocytes at birth predict respiratory tract illness in the first year of life. *J Allergy Clin Immunol* 2012;129:1267–73, e1261.
148. Forster-Waldl E, Sadeghi K, Tamandl D, Gerhold B, Hallwirth U, Rohrmeister K, et al. Monocyte toll-like receptor 4 expression and LPS-induced cytokine production increase during gestational aging. *Pediatr Res* 2005;58:121–4.
149. Sadeghi K, Berger A, Langgartner M, Prusa AR, Hayde M, Herkner K, et al. Immaturity of infection control in preterm and term newborns is associated with impaired toll-like receptor signaling. *J Infect Dis* 2007;195:296–302.
150. LeBouder E, Rey-Nores JE, Raby AC, Affolter M, Vidal K, Thornton CA, et al. Modulation of neonatal microbial recognition: TLR-mediated innate immune responses are specifically and differentially modulated by human milk. *J Immunol* 2006;176:3742–52.
151. Labeta MO, Vidal K, Nores JE, Arias M, Vita N, Morgan BP, et al. Innate recognition of bacteria in human milk is mediated by a milk-derived highly expressed pattern recognition receptor, soluble CD14. *J Exp Med* 2000;191:1807–12.
152. LeBouder E, Rey-Nores JE, Rushmere NK, Grigorov M, Lawn SD, Affolter M, et al. Soluble forms of Toll-like receptor (TLR)2 capable of modulating TLR2 signaling are present in human plasma and breast milk. *J Immunol* 2003;12:6680–9.
153. Amoudruz P, Holmlund U, Malmstrom V, Trollmo C, Bremme K, Scheynius A, et al. Neonatal immune responses to microbial stimuli: is there an influence of maternal allergy? *J Allergy Clin Immunol* 2005;115:1304–10.
154. Schaub B, Campo M, He H, Perkins D, Gillman MW, Gold DR, et al. Neonatal immune responses to TLR2 stimulation: influence of maternal atopy on Foxp3 and IL-10 expression. *Respir Res* 2006;7:40.
155. Yerkovich ST, Wikstrom ME, Suriyaarachchi D, Prescott SL, Upham JW, Holt PG. Postnatal development of monocyte cytokine responses to bacterial lipopolysaccharide. *Pediatr Res* 2007;62:547–52.
156. Caron JE, La Pine TR, Augustine NH, Martins TB, Hill HR. Multiplex analysis of toll-like receptor-stimulated neonatal cytokine response. *Neonatology* 2010;97:266–73.
157. Libraty DH, Zhang L, Woda M, Acosta LP, Obcena A, Brion JD, et al. Toll-like receptor induced pro-interleukin-1beta and interleukin-6 in monocytes are lower in healthy infants compared to adults. *PLoS ONE* 2013;8:e78018.
158. Martino D, Holt P, Prescott S. A novel role for interleukin-1 receptor signaling in the developmental regulation of immune responses to endotoxin. *Pediatr Allergy Immunol* 2012;23:567–72.
159. Nupponen I, Kuuliala A, Siitonen S, Repo H, Kuuliala K. Cord blood monocytes, neutrophils and lymphocytes from preterm and full-term neonates show multiple aberrations in signalling profiles measured using phospho-specific whole-blood flow cytometry. *Scand J Immunol* 2013;78:426–38.
160. Thornton NL, Cody MJ, Yost CC. Toll-like receptor 1/2 stimulation induces elevated interleukin-8 secretion in polymorphonuclear leukocytes isolated from preterm and term newborn infants. *Neonatology* 2012;101:140–6.
161. Belderbos ME, Levy O, Stalpers F, Kimpen JL, Meyaard L, Bont L. Neonatal plasma polarizes TLR4-mediated cytokine responses towards low IL-12p70 and high IL-10 production via distinct factors. *PLoS ONE* 2012;7:e33419.
162. Strunk T, Temming P, Gembruch U, Reiss I, Bucky P, Schultz C. Differential maturation of the innate immune response in human fetuses. *Pediatr Res* 2004;56:219–26.
163. Nomura A, Takada H, Jin CH, Tanaka T, Ohga S, Hara T. Functional analyses of cord blood natural killer cells and T cells: a distinctive interleukin-18 response. *Exp Hematol* 2001;29:1169–76.
164. Peoples JD, Cheung S, Nesin M, Lin H, Tatad AM, Hoang D, et al. Neonatal cord blood subsets and cytokine response to bacterial antigens. *Am J Perinatol* 2009;26:647–57.
165. Li J, Li H, Mao H, Yu M, Yang F, Feng T, et al. Impaired NK cell antiviral cytokine response against influenza virus in small-for-gestational-age neonates. *Cell Mol Immunol* 2013;10:437–43.
166. Eljaafari FM, Takada H, Tanaka T, Doi T, Ohga S, Hara T. Potent induction of IFN-gamma production from cord blood NK cells by the stimulation with single-stranded RNA. *J Clin Immunol* 2011;31:728–35.
167. Lisciandro JG, Prescott S, Nadal-Sims M, Devitt C, Pomat W, Siba P, et al. Ontogeny of toll-like and NOD-like receptor-mediated innate immune responses in Papua New Guinean infants. *PLoS ONE* 2012;7:e36793.
168. Lisciandro JG, Prescott SL, Nadal-Sims MG, Devitt CJ, Pomat W, Siba PM, et al. Comparison of neonatal T regulatory cell function in Papua New Guinean and Australian newborns. *Pediatr Allergy Immunol* 2012;23:173–80.
169. Lisciandro JG, Prescott SL, Nadal-Sims MG, Devitt CJ, Richmond PC, Pomat W, et al. Neonatal antigen-presenting cells are functionally more quiescent in children born under traditional compared with modern environmental conditions. *J Allergy Clin Immunol* 2012;130:1167–74, e1110.
170. Smolen KK, Ruck CE, Fortuno ES 3rd, Ho K, Dimitriu P, Mohn WW, et al. Pattern recognition receptor-mediated cytokine response in infants across 4 continents. *J Allergy Clin Immunol* 2014;133:818–26, e814.
171. Barbouche R, Forveille M, Fischer A, Avrameas S, Durandy A. Spontaneous IgM autoantibody production in vitro by B lymphocytes of normal human neonates. *Scand J Immunol* 1992;35:659–67.
172. Durandy A, Thuillier L, Forveille M, Fischer A. Phenotypic and functional characteristics of human newborns' B lymphocytes. *J Immunol* 1990;144:60–5.
173. Casali P, Notkins AL. CD5<sup>+</sup> B lymphocytes polyreactive antibodies and the human B-cell repertoire. *Immunol Today* 1989;10:364–7.
174. Watson W, Oen K, Ramdahin R, Harman C. Immunglobulin and cytokine production by neonatal lymphocytes. *Clin Exp Immunol* 1991;83:169–74.
175. Caligaris-Cappio F, Riva M, Tesio L, Schena M, Gaidano G, Bergui L. Human normal CD5<sup>+</sup> B lymphocytes can be induced to differentiate to CD5<sup>-</sup> B lymphocytes with germinal center cell features. *Blood* 1989;73:1259–64.
176. Punnonen J. The role of interleukin-2 in the regulation of proliferation and IgM synthesis of human newborn mononuclear cells. *Clin Exp Immunol* 1989;75:421–5.
177. Lewis DB, Wilson CB. Developmental immunology and role of host defenses in fetal and neonatal susceptibility to infection. In: Remington JS, Klein JO, editors. *Infectious diseases of the fetus and newborn infant*. Philadelphia: W.B. Saunders; 2001.
178. Splawski JB, Nishioka J, Nishioka Y, Lipsky PE. CD40 ligand is expressed and functional on activated T cells. *J Immunol* 1996;156:119–27.
179. Stavnezer J. Antibody class switching. *Adv Immunol* 1996;61:79–146.
180. Gauchat J-F, Gauchat D, De Weck AL, Stadler BM. Cytokine mRNA levels in antigen-stimulated peripheral blood mononuclear cells. *Eur J Immunol* 1989;19:804–10.
181. Lundell AC, Johansen S, Adlerberth I, Wold AE, Hesselmar B, Rudin A. High proportion of CD5<sup>+</sup> B cells in infants predicts development of allergic disease. *J Immunol* 2014;193:510–18.
182. Lanning DK, Rhee KJ, Knight KL. Intestinal bacteria and development of the B-lymphocyte repertoire. *Trends Immunol* 2005;26:419–25.
183. Lundell AC, Bjornsson V, Ljung A, Ceder M, Johansen S, Lindhagen G, et al. Infant B cell memory differentiation and early gut bacterial colonization. *J Immunol* 2012;188:4315–22.
184. Rudin A, Lundell AC. Infant B cell memory and gut bacterial colonization. *Gut Microbes* 2012;3:474–5.
185. Bouaziz JD, Yanaba K, Tedder TF. Regulatory B cells as inhibitors of immune responses and inflammation. *Immunol Rev* 2008;224:201–14.
186. van de Veen W, Stanic B, Yaman G, Wawrzyniak M, Sollner S, Akdis DG, et al. IgG4 production is confined to human IL-10-producing regulatory B cells that suppress antigen-specific immune responses. *J Allergy Clin Immunol* 2013;131:1204–12.
187. Walters SN, Webster KE, Daley S, Grey ST. A role for intrathymic B cells in the generation of natural regulatory T cells. *J Immunol* 2014;193:170–6.
188. Morris JF, Hoyer JT, Pierce SK. Antigen presentation for T cell interleukin-2 secretion is a late acquisition of neonatal B cells. *Eur J Immunol* 1992;22:2923–8.
189. Van Tol MJD, Zijlstra J, Thomas CMG, Zegers BJM, Ballieux RE. Distinct role of neonatal and adult monocytes in the regulation of the *in vitro* antigen-induced plaque-forming cell response in man. *J Immunol* 1984;133:1902–8.
190. Serushago B, Issekutz AC, Lee SH, Rajaraman K, Bortolussi R. Deficient tumor necrosis



- factor secretion by cord blood mononuclear cells upon *in vitro* stimulation with *Listeria monocytogenes*. *J Interferon Cytokine Res* 1996;16:381–7.
191. Weston WL, Carson BS, Barkin RM, Slater GD, Dustin RD, Hecht SK. Monocyte-macrophage function in the newborn. *Am J Dis Child* 1977; 131:1241–2.
  192. Clerici M, DePalma L, Roilides E, Baker R, Shearer GM. Analysis of T helper and antigen-presenting cell functions in cord blood and peripheral blood leukocytes from healthy children of different ages. *J Clin Invest* 1993; 91:2829–36.
  193. Stiehm ER, Szein MB, Oppenheim JJ. Deficient DR antigen expression on human cord blood monocytes: reversal with lymphokines. *Clin Immunol Immunopathol* 1984;30: 430–6.
  194. Holt PG. Regulation of antigen-presenting cell function(s) in lung and airway tissues. *Eur Respir J* 1993;6:120–9.
  195. Lee PT, Holt PG, McWilliam AS. Ontogeny of rat pulmonary alveolar function: Evidence for a selective deficiency in IL-10 and nitric oxide production by newborn alveolar macrophages. *Cytokine* 2001;15:53–7.
  196. Chesnut RW, Grey HM. Antigen presentation by B cells and its significance in T-B interactions. *Adv Immunol* 1986;39:51–82.
  197. Pierce SK, Morris JF, Grusby MJ, Kaumaya P, van Buskirk A, Srinivasan M, et al. Antigen-presenting function of B lymphocytes. *Immunol Rev* 1988;106:149–56.
  198. Muthukkumar S, Goldstein J, Stein KE. The ability of B cells and dendritic cells to present antigen increases ontogeny. *J Immunol* 2000; 165:4803–13.
  199. Steinman RM. The dendritic cell system and its role in immunogenicity. *Annu Rev Immunol* 1991;9:271–96.
  200. Janeway CA. The immune response evolved to discriminate infectious nonself from noninfectious self. *Immunol Today* 1992;13:11–16.
  201. McWilliam AS, Napoli S, Marsh AM, Pemper FL, Nelson DJ, Pimm CL, et al. Dendritic cells are recruited into the airway epithelium during the inflammatory response to a broad spectrum of stimuli. *J Exp Med* 1996;184: 2429–32.
  202. Matzinger P. Tolerance, danger, and the extended family. *Annu Rev Immunol* 1994;12: 991–1045.
  203. Holt PG, Stumbles PA. Regulation of immunologic homeostasis in peripheral tissues by dendritic cells: The respiratory tract as a paradigm. *J Allergy Clin Immunol* 2000;105:421–9.
  204. Foster CA, Holbrook KA. Ontogeny of Langerhans cells in human embryonic and fetal skin: cell densities and phenotypic expression relative to epidermal growth. *Am J Anat* 1989; 184:157–64.
  205. Mizoguchi S, Takahashi K, Takeya M, Naito M, Morioka T. Development, differentiation and proliferation of epidermal Langerhans cells in rat ontogeny studied by a novel monoclonal antibody against epidermal Langerhans cells, RED-1. *J Leukoc Biol* 1992;52:52–61.
  206. Romani N, Schuler G, Fritsch P. Ontogeny of Ia-positive and Thy-1-positive leukocytes of murine epidermis. *J Invest Dermatol* 1986; 86:129–33.
  207. Mayrhofer G, Pugh CW, Barclay AN. The distribution, ontogeny and origin in the rat of Ia-positive cells with dendritic morphology and of Ia antigen in epithelia, with special reference to the intestine. *Eur J Immunol* 1983; 13:112–22.
  208. Brandtzaeg P, Halstensen TS, Huitfeldt HS, Krajci P, Kvale D, Scott H, et al. Epithelial expression of HLA, secretory component (poly-Ig receptor), and adhesion molecules in the human alimentary tract. *Ann N Y Acad Sci* 1992;664:157–79.
  209. McCarthy KM, Gong JL, Telford JR, Schneeberger EE. Ontogeny of Ia+ accessory cells in fetal and newborn rat lung. *Am J Respir Cell Mol Biol* 1992;6:349–56.
  210. Nelson DJ, McMenamin C, McWilliam AS, Brenan M, Holt PG. Development of the airway intraepithelial dendritic cell network in the rat from class II major histocompatibility (Ia)-negative precursors: differential regulation of Ia expression at different levels of the respiratory tract. *J Exp Med* 1994;179:203–12.
  211. Ridge JP, Fuchs EJ, Matzinger P. Neonatal tolerance revisited: turning on newborn T cells with dendritic cells. *Science* 1996;271:1723–6.
  212. Nelson DJ, Holt PG. Defective regional immunity in the respiratory tract of neonates is attributable to hyporesponsiveness of local dendritic cells to activation signals. *J Immunol* 1995;155:3517–24.
  213. Stoltenberg L, Thrane PS, Rognum TO. Development of immune response markers in the trachea in the fetal period and the first year of life. *Pediatr Allergy Immunol* 1993;4: 13–19.
  214. Holt PG. Dendritic cell ontogeny as an aetiological factor in respiratory tract diseases in early life. *Thorax* 2001;56:419–20.
  215. Heier I, Malmstrom K, Pelkonen AS, Malmberg LP, Kajosaari M, Turpeinen M, et al. Bronchial response pattern of antigen presenting cells and regulatory T cells in children less than 2 years of age. *Thorax* 2008;63:703–9.
  216. Sorg RV, Kogler G, Wernet P. Identification of cord blood dendritic cells as an immature CD11c-population. *Blood* 1999;93:2302–7.
  217. Upham JW, Zhang G, Rate A, Yerkovich ST, Kusel M, Sly PD, et al. Plasmacytoid dendritic cells during infancy are inversely associated with childhood respiratory tract infections and wheezing. *J Allergy Clin Immunol* 2009;124: 707–13, e702.
  218. Hunt DW, Huppertz HI, Jiang HJ, Petty RE. Studies of human cord blood dendritic cells: evidence for functional immaturity. *Blood* 1994;84:4333–43.
  219. Prescott SL, Taylor A, King B, Dunstan J, Upham JW, Thornton CA, et al. Neonatal interleukin-12 capacity is associated with variations in allergen-specific immune responses in the neonatal and postnatal periods. *Clin Exp Allergy* 2003;33:566–72.
  220. Goriely S, Vincart B, Stordeur P, Vekemans J, Willems F, Goldman M, et al. Deficient IL-12(p35) gene expression by dendritic cells derived from neonatal monocytes. *J Immunol* 2001;166:2141–6.
  221. Gold MC, Robinson TL, Cook MS, Byrd LK, Ehlinger HD, Lewinsohn DM, et al. Human neonatal dendritic cells are competent in MHC class I antigen processing and presentation. *PLoS ONE* 2007;2:e957.
  222. Krumbiegel D, Zepp F, Meyer CU. Combined Toll-like receptor agonists synergistically increase production of inflammatory cytokines in human neonatal dendritic cells. *Hum Immunol* 2007;68:813–22.
  223. Krumbiegel D, Anthogalidis-Voss C, Markus H, Zepp F, Meyer CU. Enhanced expression of IL-27 mRNA in human newborns. *Pediatr Allergy Immunol* 2008;19:513–16.
  224. Kim CK, Choi J, Kim HB, Callaway Z, Shin BM, Kim JT, et al. A randomized intervention of montelukast for post-bronchiolitis: effect on eosinophil degranulation. *J Pediatr* 2010; 156:749–54.
  225. Kim CK, Callaway Z, Koh YY, Kim SH, Fujisawa T. Airway IFN-gamma production during RSV bronchiolitis is associated with eosinophilic inflammation. *Lung* 2012;190: 183–8.
  226. Bullock JD, Robertson AF, Bodenbender JG, Kontras SB, Miller CE. Inflammatory response in the neonate re-examined. *Pediatrics* 1969; 44:58–61.
  227. Eitzman DV, Smith RT. The nonspecific inflammatory cycle in the neonatal infant. *Am J Dis Child* 1959;97:326–34.
  228. Roberts RL, Ank BJ, Salusky IB, Stiehm ER. Purification and properties of peritoneal eosinophils from pediatric dialysis patients. *J Immunol Methods* 1990;126:205–11.
  229. Gibson EL, Vaucher Y, Corrigan JJ. Eosinophilia in premature infants: relationship to weight gain. *J Pediatr* 1979;95:99–101.
  230. Bhat AM, Scanlon JW. The pattern of eosinophilia in premature infants. *J Pediatr* 1981; 98:612–16.
  231. Smith JB, Kunjummen RD, Raghavender BH. Eosinophils and neutrophils of human neonates have similar impairments of quantitative up-regulation of Mac-1 (CD11b/CD18) expression *in vitro*. *Pediatr Res* 1991;30: 355–61.
  232. Smith JB, Kunjummen RD, Kishimoto TK, Anderson DC. Expression and regulation of L-selectin on eosinophils from human adults and neonates. *Pediatr Res* 1992;32: 465–71.
  233. Reece P, Thanendran A, Crawford L, Tulic MK, Thabane L, Prescott SL, et al. Maternal allergy modulates cord blood hematopoietic progenitor Toll-like receptor expression and function. *J Allergy Clin Immunol* 2011;127:447–53.
  234. Yang L, Xu WG, Xu YP, Guo YS, Xiong Y, Shi GY. The effect of peptidoglycan stimulation on basophil-mediated atopic responses during pregnancy and in newborns. *J Asthma* 2011;48:374–9.
  235. Spencer J, Isaacson PG, Walker-Smith JA, MacDonald TT. Heterogeneity in intraepithelial lymphocyte subpopulations in fetal and postnatal human small intestine. *J Pediatr Gastroenterol Nutr* 1989;9:173–7.
  236. Wilkes LK, McMenamin C, Holt PG. Postnatal maturation of mast cell subpopulations in the rat respiratory tract. *Immunology* 1992;75: 535–41.
  237. Cummins AG, Munro GH, Miller HRP, Ferguson A. Association of maturation of the small intestine at weaning with mucosal mast cell activation in the rat. *J Cell Biol* 1988;66 (Pt 5-6):417–23.
  238. Cummins AG, Eglinton BA, Gonzalez A, Robertson DM. Immune activation during infancy in healthy humans. *J Clin Immunol* 1994;14:107–15.
  239. Iida M, Matsumoto K, Tomita H, Nakajima T, Akasawa A, Ohtani NY, et al. Selective down-regulation of high-affinity IgE receptor (FcεRI) a-chain messenger RNA among transcriptome in cord blood-derived versus adult peripheral



- blood-derived cultured human mast cells. *Blood* 2001;97:1016–22.
240. Kondo N, Kobayashi Y, Shinoda S, Kasahara K, Kameyama T, Iwasa S, et al. Cord blood lymphocyte responses to food antigens for the prediction of allergic disorders. *Arch Dis Child* 1992;67:1003–7.
  241. Piccinni MP, Mecacci F, Sampognaro S, Manetti R, Parronchi P, Maggi E, et al. Aeroallergen sensitization can occur during fetal life. *Int Arch Allergy Immunol* 1993;102:301–3.
  242. Piastra M, Stabile A, Fioravanti G, Castagnola M, Pani G, Ria F. Cord blood mononuclear cell responsiveness to beta-lactoglobulin: T-cell activity in 'atopy-prone' and 'non-atopy-prone' newborns. *Int Arch Allergy Immunol* 1994;104:358–65.
  243. Holt PG, O'Keefe PO, Holt BJ, Upham JW, Baron-Hay MJ, Suphioglu C, et al. T-cell 'priming' against environmental allergens in human neonates: sequential deletion of food antigen specificities during infancy with concomitant expansion of responses to ubiquitous inhalant allergens. *Pediatr Allergy Immunol* 1995;6:85–90.
  244. Miles EA, Warner JA, Jones AC, Colwell BM, Bryant TN, Warner JO. Peripheral blood mononuclear cell proliferative responses in the first year of life in babies born to allergic parents. *Clin Exp Allergy* 1996;26:780–8.
  245. Prescott SL, Macaubas C, Holt BJ, Smallacombe T, Loh R, Sly PD, et al. Transplacental priming of the human immune system to environmental allergens: universal skewing of initial T-cell responses towards the Th-2 cytokine profile. *J Immunol* 1998;160:4730–7.
  246. Szeplafusi Z, Loibichler C, Pichler J, Reisenberger K, Ebner C, Urbanek R. Direct evidence for transplacental allergen transfer. *Pediatr Res* 2000;48:404–7.
  247. Bonnelykke K, Pipper CB, Bisgaard H. Sensitization does not develop in utero. *J Allergy Clin Immunol* 2008;121:646–51.
  248. Holt P, Rowe J, Kusel M, Parsons F, Hollams E, Bosco A, et al. Towards improved prediction of risk for atopy and asthma amongst preschoolers: a prospective birth cohort. *J Allergy Clin Immunol* 2010;125:645–51.
  249. Björkstén B, Holt BJ, Baron-Hay MJ, Munir AKM, Holt PG. Low-level exposure to house dust mites stimulates T-cell responses during early childhood independent of atopy. *Clin Exp Allergy* 1996;26:775–9.
  250. Smillie FI, Elderfield AJ, Patel F, Cain G, Tavenier G, Brutsche M, et al. Lymphoproliferative responses in cord blood and at one year: no evidence for the effect of *in utero* exposure to dust mite allergens. *Clin Exp Allergy* 2001;31:1194–204.
  251. Yabuhara A, Macaubas C, Prescott SL, Venaille T, Holt BJ, Habre W, et al. Th-2-polarised immunological memory to inhalant allergens in atopics is established during infancy and early childhood. *Clin Exp Allergy* 1997;27:1261–9.
  252. Prescott SL, Macaubas C, Smallacombe T, Holt BJ, Sly PD, Holt PG. Development of allergen-specific T-cell memory in atopic and normal children. *Lancet* 1999;353:196–200.
  253. Macaubas C, Sly PD, Burton P, Tiller K, Yabuhara A, Holt BJ, et al. Regulation of T-helper cell responses to inhalant allergen during early childhood. *Clin Exp Allergy* 1999;29:1223–31.
  254. Macaubas C, Holt PG. Regulation of cytokine production in T-cell responses to inhalant allergen: GATA-3 expression distinguishes between Th1 and Th2-polarised immunity. *Int Arch Allergy Immunol* 2001;124:176–9.
  255. Macaubas C, Lee PT, Smallacombe TB, Holt BJ, Wee C, Sly PD, et al. Reciprocal patterns of allergen-induced GATA-3 expression in peripheral blood mononuclear cells from atopics versus non-atopics. *Clin Exp Allergy* 2002;32:97–106.
  256. Rinas U, Horneff G, Wahn V. Interferon-gamma production by cord-blood mononuclear cells is reduced in newborns with a family history of atopic disease and is independent from cord blood IgE-levels. *Pediatr Allergy Immunol* 1993;4:60–4.
  257. Tang MLK, Kemp AS, Thorburn J, Hill DJ. Reduced interferon-gamma secretion in neonates and subsequent atopy. *Lancet* 1994;344:983–6.
  258. Liao SY, Liao TN, Chiang BL, Huang MS, Chen CC, Chou CC, et al. Decreased production of IFN $\gamma$  and increased production of IL-6 by cord blood mononuclear cells of newborns with a high risk of allergy. *Clin Exp Allergy* 1996;26:397–405.
  259. Martinez FD, Stern DA, Wright AL, Holberg CJ, Taussig LM, Halonen M. Association of interleukin-2 and interferon- $\gamma$  production by blood mononuclear cells in infancy with parental allergy skin tests and with subsequent development of atopy. *J Allergy Clin Immunol* 1995;96(5 Pt 1):652–60.
  260. Warner JA, Miles EA, Jones AC, Quint DJ, Colwell BM, Warner JO. Is deficiency of interferon gamma production by allergen triggered cord blood cells a predictor of atopic eczema? *Clin Exp Allergy* 1994;24:423–30.
  261. Williams TJ, Jones CA, Miles EA, Warner JO, Warner JA. Fetal and neonatal IL-13 production during pregnancy and at birth and subsequent development of atopic symptoms. *J Allergy Clin Immunol* 2000;105:951–9.
  262. Holt PG, Macaubas C. Development of long term tolerance versus sensitisation to environmental allergens during the perinatal period. *Curr Opin Immunol* 1997;9:782–7.
  263. D'Vaz N, Ma Y, Dunstan JA, Lee-Pullen TF, Hii C, Meldrum S, et al. Neonatal protein kinase C zeta expression determines the neonatal T-cell cytokine phenotype and predicts the development and severity of infant allergic disease. *Allergy* 2012;67:1511–18.
  264. Holt PG. Environmental factors and primary T-cell sensitisation to inhalant allergens in infancy: reappraisal of the role of infections and air pollution. *Pediatr Allergy Immunol* 1995;6:1–10.
  265. Martinez FD, Holt PG. The role of microbial burden in the aetiology of allergy and asthma. *Lancet* 1999;354(Suppl. 2):12–15.
  266. Tulic MK, Hodder M, Forsberg A, McCarthy S, Richman T, D'Vaz N, et al. Differences in innate immune function between allergic and nonallergic children: new insights into immune ontogeny. *J Allergy Clin Immunol* 2011;2:470–8 e471.
  267. Baldini M, Lohman IC, Halonen M, Erickson RP, Holt PG, Martinez FD. A polymorphism in the 5'-flanking region of the CD14 gene is associated with circulating soluble CD14 levels with total serum IgE. *Am J Respir Cell Mol Biol* 1999;20:976–83.
  268. Hartel C, Rupp J, Hoegemann A, Bohler A, Spiegler J, von Otte S, et al. 159C>T CD14 genotype – functional effects on innate immune responses in term neonates. *Hum Immunol* 2008;69:338–43.
  269. Von Ehrenstein OS, Von Mutius E, Illi S, Baumann L, Von Kries R. Reduced risk of hay fever and asthma amongst children of farmers. *Clin Exp Allergy* 2000;62:187–93.
  270. Gereda JE, Leung DYM, Thatayatikom A, Streib JE, Price MR, Klinnert MD, et al. Relation between house-dust endotoxin exposure, type 1 T-cell development, and allergen sensitisation in infants at high risk of asthma. *Lancet* 2000;355:1680–3.
  271. von Mutius E, Radon K. Living on a farm: impact on asthma induction and clinical course. *Immunol Allergy Clin North Am* 2008;28:631–47, ix–x.
  272. Conrad ML, Ferstl R, Teich R, Brand S, Blumer N, Yildirim AO, et al. Maternal TLR signaling is required for prenatal asthma protection by the nonpathogenic microbe *Acinetobacter lwoffii* F78. *J Exp Med* 2009;206:2869–77.
  273. Holt PG, Strickland DH. Soothing signals: transplacental transmission of resistance to asthma and allergy. *J Exp Med* 2009;206:2861–4.
  274. Loss G, Bitter S, Wohlgensinger J, Frei R, Roduit C, Genuneit J, et al. Prenatal and early-life exposures alter expression of innate immunity genes: the PASTURE cohort study. *J Allergy Clin Immunol* 2012;130:523–30 e529.
  275. Roduit C, Wohlgensinger J, Frei R, Bitter S, Bieli C, Loeliger S, et al. Prenatal animal contact and gene expression of innate immunity receptors at birth are associated with atopic dermatitis. *J Allergy Clin Immunol* 2011;127:179–85, 185 e171.
  276. Lluís A, Depner M, Gaugler B, Saas P, Casaca VI, Raedler D, et al. Increased regulatory T-cell numbers are associated with farm milk exposure and lower atopic sensitization and asthma in childhood. *J Allergy Clin Immunol* 2014;133:551–9.
  277. Schaub B, Liu J, Hoppler S, Schleich I, Huehn J, Olek S, et al. Maternal farm exposure modulates neonatal immune mechanisms through regulatory T cells. *J Allergy Clin Immunol* 2009;123:774–82, e775.
  278. Yamamoto Y, Negoro T, Hoshi A, Wakagi A, Shimizu S, Banham AH, et al. Impaired Ca(2+)-regulation of CD4(+)CD25(+) regulatory T cells from pediatric asthma. *Int Arch Allergy Immunol* 2011;156:148–58.
  279. Hrdy J, Kocourkova I, Prokesova L. Impaired function of regulatory T cells in cord blood of children of allergic mothers. *Clin Exp Immunol* 2012;170:10–17.
  280. Roponen M, Hyvarinen A, Hirvonen MR, Keski-Nisula L, Pekkanen J. Change in IFN-gamma-producing capacity in early life and exposure to environmental microbes. *J Allergy Clin Immunol* 2005;116:1048–52.
  281. Rowe J, Macaubas C, Monger T, Holt BJ, Harvey J, Poolman JT, et al. Heterogeneity in diphtheria-tetanus-acellular pertussis vaccine-specific cellular immunity during infancy: relationship to variations in the kinetics of postnatal maturation of systemic Th1 function. *J Infect Dis* 2001;184:80–8.
  282. Rowe J, Heaton T, Kusel M, Suriyaarachchi D, Serralha M, Holt BJ, et al. High IFN-gamma production by CD8+ T cells and early sensitization among infants at high risk of atopy. *J Allergy Clin Immunol* 2004;113:710–16.
  283. Heaton T, Rowe J, Turner S, Aalberse RC, de Klerk N, Suriyaarachchi D, et al. An

- immunoepidemiological approach to asthma: identification of in-vitro T-cell response patterns associated with different wheezing phenotypes in children. *Lancet* 2005;365:142–9.
284. Hollams EM, Deverell M, Serralha M, Suriyaarachchi D, Parsons F, Zhang G, et al. Elucidation of asthma phenotypes in atopic teenagers through parallel immunophenotypic and clinical profiling. *J Allergy Clin Immunol* 2009;124:463–70, 470, e461–416.
  285. Kerzel S, Dehne J, Rogosch T, Schaub B, Maier RF, Zemlin M. Th17 cell frequency in peripheral blood from children with allergic asthma correlates with the level of asthma control. *J Pediatr* 2012;161:1172–4.
  286. Halonen M, Lohman IC, Stern DA, Ellis WL, Rothers J, Wright AL. Perinatal tumor necrosis factor-alpha production, influenced by maternal pregnancy weight gain, predicts childhood asthma. *Am J Respir Crit Care Med* 2013;188:35–41.
  287. Woolcock AJ, Peat JK, Trevillion LM. Is the increase in asthma prevalence linked to increase in allergen load? *Allergy* 1995;50:935–40.
  288. Peat JK, Salome CM, Woolcock AJ. Longitudinal changes in atopy during a 4-year period: Relation to bronchial hyperresponsiveness and respiratory symptoms in a population sample of Australian schoolchildren. *J Allergy Clin Immunol* 1990;85(1 Pt 1):65–74.
  289. Martinez FD, Wright AL, Taussig LM, Holberg CJ, Halonen M, Morgan WJ. Asthma and wheezing in the first six years of life. The Group Health Medical Associates. *N Engl J Med* 1995;332:133–8.
  290. Welliver RC, Duffy L. The relationship of RSV-specific immunoglobulin E antibody responses in infancy, recurrent wheezing, and pulmonary function at age 7–8 years. *Pediatr Pulmonol* 1993;15:19–27.
  291. Oddy WH, de Klerk NH, Sly PD, Holt PG. The effects of respiratory infections, atopy, and breastfeeding on childhood asthma. *Eur Respir J* 2002;19:899–905.
  292. Holgate S. The inflammation-repair cycle in asthma: the pivotal role of the airway epithelium. *Clin Exp Allergy* 1998;28(Suppl. 5):97–103.
  293. Holt PG, Sly PD. Viral infections and atopy in asthma pathogenesis: new rationales for asthma prevention and treatment. *Nat Med* 2012;18:726–35.
  294. Hossein-Nezhad A, Spira A, Holick MF. Influence of vitamin D status and vitamin D3 supplementation on genome wide expression of white blood cells: a randomized double-blind clinical trial. *PLoS ONE* 2013;8:e58725.
  295. Pinheiro da Silva F, Machado MC. Antimicrobial peptides: clinical relevance and therapeutic implications. *Peptides* 2012;36:308–14.
  296. Walker VP, Zhang X, Rastegar I, Liu PT, Hollis BW, Adams JS, et al. Cord blood vitamin D status impacts innate immune responses. *J Clin Endocrinol Metab* 2011;96:1835–43.
  297. Mohamed WA, Al-Shehri MA, Mohamed WAW. Cord blood 25-hydroxyvitamin D levels and the risk of acute lower respiratory tract infection in early childhood. *J Trop Pediatr* 2013;59:29–35.
  298. Urry Z, Chambers ES, Xystrakis E, Dimeloe S, Richards DE, Gabrysova L, et al. The role of 1,25-dihydroxyvitamin D3 and cytokines in the promotion of distinct Foxp3+ and IL-10+ CD4+ T cells. *Eur J Immunol* 2012;42:2697–708.
  299. Milovanovic M, Heine G, Hallatschek W, Opitz B, Radbruch A, Worm M, et al. Vitamin D receptor binds to the epsilon germline gene promoter and exhibits transrepressive activity. *J Allergy Clin Immunol* 2010;126:1016–23.
  300. Zittermann A, Dembinski J, Stehle P. Low vitamin D status is associated with low cord blood levels of the immunosuppressive cytokine interleukin-10. *Pediatr Allergy Immunol* 2004;15:242–6.
  301. Guven A, Ecevit A, Sozer O, Tarcan A, Ozbek N. Correlation between the cord vitamin D levels and regulatory T cells in newborn infants. *Eur J Pediatr* 2012;171:1161–6.
  302. Rochat MK, Ege MJ, Plabst D, Steinle J, Bitter S, Braun-Fahrlander C, et al. Maternal vitamin D intake during pregnancy increases gene expression of ILT3 and ILT4 in cord blood. *Clin Exp Allergy* 2010;40:786–94.
  303. Hewison M. Vitamin D, immunity and human disease. *Clin Rev Bone Miner Metab* 2010;1:32–9.
  304. Hollams EM. Vitamin D and atopy and asthma phenotypes in children. *Curr Opin Allergy Clin Immunol* 2012;12:228–34.
  305. Stumbles PA, Thomas JA, Pimm CL, Lee PT, Venaille TJ, Proksch S, et al. Resting respiratory tract dendritic cells preferentially stimulate Th2 responses and require obligatory cytokine signals for induction of Th1 immunity. *J Exp Med* 1998;188:2019–31.
  306. Schon-Hegrad MA, Oliver J, McMenamin PG, Holt PG. Studies on the density, distribution, and surface phenotype of intraepithelial class II major histocompatibility complex antigen (Ia)-bearing dendritic cells (DC) in the conducting airways. *J Exp Med* 1991;173:1345–56.
  307. McWilliam AS, Nelson D, Thomas JA, Holt PG. Rapid dendritic cell recruitment is a hallmark of the acute inflammatory response at mucosal surfaces. *J Exp Med* 1994;179:1331–6.
  308. Holt PG, Strickland DH, Hales BJ, Sly PD. Defective respiratory tract immune surveillance in asthma. *Chest* 2014;145:370–8.
  309. Sly PD, Boner AL, Bjorksten B, Bush A, Custovic A, Eigenmann PA, et al. Early identification of atopy in the prediction of the development of persistent asthma in children. *Lancet* 2008;372:1100–6.

# Approach to the Child with Recurrent Infections Including Molecular Diagnostics

HOWARD M. LEDERMAN

## KEY POINTS

- Chronic/recurrent respiratory tract infections are common problems for children with allergy but may also be the presenting symptoms of an underlying defect in host defense such as primary and secondary immunodeficiency, cystic fibrosis, ciliary dyskinesia and dysfunctional swallowing.
- Diagnosis of an underlying disorder is essential for optimal clinical management.
- Presenting features of immunodeficiency include increased susceptibility to infection (chronic or recurrent infections, infections of unusual severity, infections caused by opportunistic pathogens), autoimmune/inflammatory disorders and syndrome complexes.
- The types of infections and other symptoms should guide the choice of screening laboratory tests.
- Mutation analysis can confirm the diagnosis and facilitate genetic counseling and screening of other family members who may be asymptomatic.

Many children who present for allergy evaluation have chronic/recurrent respiratory tract infections. Allergy may predispose the patient to such symptoms because swelling of the nasal mucosa causes obstruction of the sinus ostia and eustachian tubes. However, one must be alert to the possibility of other underlying problems, including primary immunodeficiency diseases, secondary immunodeficiency caused by other illnesses or medications, cystic fibrosis, ciliary disorders and pulmonary aspiration. Environmental factors such as exposure to cigarette smoke, day care and the number of household members must also be considered. This chapter provides an approach to evaluating children for these disorders.

## Definition of Recurrent Infections

It is difficult to define increased susceptibility to infection with precision (Box 7-1).<sup>1</sup> For example, chronic/recurrent otitis media is very common in the first two years of life but thereafter decreases in frequency. Rather than defining an arbitrary number of ear infections that is 'too many', the nature and pattern of those infections provide a more reliable guide to identify the child who deserves further evaluation. Ear infections that increase in frequency after the age of 2 years, are associated with infections at other sites or occur in the context of failure to thrive should raise the suspicion of an underlying

disorder. Similarly, it is unusual for a child to have more than one episode of pneumonia per decade of life, chronic or recurrent sinusitis or bronchitis.

Other clues to an abnormal susceptibility to infection include a history of infections at multiple anatomic locations or relatively unusual infections such as sepsis, septic arthritis, osteomyelitis and meningitis. In some instances, patients may present with one or more infections that are unusually severe, lead to an unexpected complication (e.g. pneumonia with empyema or otitis media with mastoiditis) or are caused by an organism of relatively low virulence (e.g. *Aspergillus* or *Pneumocystis jirovecii*).

Sometimes, the most challenging aspect of evaluating the past medical history is assessing the reliability of the data. It may be difficult to distinguish pneumonia from atelectasis with fever in children with reactive airway disease. Sinusitis is easily mistaken for purulent rhinitis, unless a computed tomography scan documents sinus involvement. Diarrhea may be the result of infection or an adverse effect of antibiotic therapy. Finally, the infections in a patient with an immunodeficiency may not be severe or progressive because of rapid institution of antibiotic therapy. Indeed, many patients ultimately diagnosed with a primary immunodeficiency present with an infection history that is not distinguishable from normal children.

It is also important to account for environmental exposure. There is an obvious explanation for frequent infections in an infant attending a large daycare center during the winter months, whereas the same number of infections might raise concern in an only child cared for in the home. Similarly, exposure to cigarette smoke and drinking from a bottle in a supine position are known risk factors for a variety of respiratory tract symptoms including infections. A sometimes useful clue is whether the child has had distinctly more infections than his/her siblings by a comparable age.

Early diagnosis of an underlying disorder is critical because it may lead to more effective approaches to therapy and appropriate anticipatory guidance. Furthermore, because some underlying disorders are inherited in Mendelian fashion, early diagnosis is essential for making genetic information available to the families of affected individuals.

## The Clinical Presentation of Underlying Disorders

### ALLERGY

Patients with allergic disease, rhinitis and/or asthma often have symptoms of both acute and chronic sinusitis.<sup>2</sup> There is little to

**BOX 7-1 GUIDELINES FOR IDENTIFYING CHILDREN WITH INCREASED SUSCEPTIBILITY TO INFECTION****Frequency**

- More than one episode of pneumonia per decade of life
- Increasing frequency of otitis media in children older than 2 years
- Persistent otitis media and drainage despite patent tympanostomy tubes
- Persistent sinusitis despite medical and, when appropriate, surgical treatment

**Severity**

- Pneumonia with empyema
- Bacterial meningitis, arthritis or osteomyelitis
- Sepsis
- Mastoiditis

**Infection with opportunistic pathogens**

- Pneumocystis jirovecii* pneumonia
- Mucocutaneous candidiasis
- Invasive fungal infection
- Vaccine-acquired poliomyelitis
- Bacille Calmette-Guérin infection after vaccination

**Infections at multiple anatomic locations****Lack of other epidemiologic explanations (e.g. daycare center, exposure to cigarette smoke, environmental allergies)****Anatomic or physiologic features suggestive of a syndrome complex****Failure to thrive**

distinguish the symptoms or mucopurulent discharge in patients with immunodeficiency compared with those with allergic disease. Similarly, radiographic studies do not discriminate between the two. History is important because flare-ups of sinusitis often accompany exacerbations of the underlying allergic symptoms, and patients may report more symptomatic improvement when treated with corticosteroids than when treated with antibiotics. In general, a history of atopy makes a diagnosis of immunodeficiency less likely because the ability to produce specific IgE antibodies usually indicates normal B and T cell function. However, there are several exceptions to this generality. These include Wiskott-Aldrich syndrome (thrombocytopenia, eczema, immunodeficiency), hyper-IgE syndromes (severe atopic dermatitis and a history of retained primary teeth, bone fractures, pneumonia sometimes with empyema, or chronic/recurrent cutaneous viral infections such as warts and molluscum contagiosum) and the syndrome of X-linked immunodeficiency/dysregulation with polyendocrinopathy and enteropathy or IPEX<sup>3</sup> (males who present early in life with severe atopic dermatitis, food and environmental allergies in association with endocrinopathy, especially insulin-dependent diabetes, and chronic diarrhea).

Recurrent sinopulmonary infections are also the most frequent illnesses associated with selective IgA deficiency, and IgA deficiency and allergy may be associated with each other. Even in blood bank donors in whom IgA deficiency was accidentally discovered, allergy may be twice as common as in healthy donors.<sup>4</sup> The most common allergic disorders in IgA-deficient individuals are rhinosinusitis, eczema, conjunctivitis and asthma.<sup>5</sup>

Because of the association between allergy and sinusitis, a careful history may often be sufficient, obviating the need for extensive testing for immunodeficiency. Screening for IgA deficiency may be of some help in understanding the association

**BOX 7-2 CLINICAL FEATURES OF IMMUNODEFICIENCY****Increased susceptibility to infection**

- Chronic/recurrent infections without other explanations
- Infection with organism of low virulence
- Infection of unusual severity

**Autoimmune or inflammatory disease**

- Target cells (e.g. hemolytic anemia, immune thrombocytopenia, thyroiditis)
- Target tissues (e.g. rheumatoid arthritis, vasculitis, systemic lupus erythematosus)

**Syndrome complexes**

between the two in IgA-deficient individuals. Management of sinusitis should be medical with avoidance of surgery, unless all else fails.

**IMMUNODEFICIENCY**

The primary immunodeficiency diseases were originally viewed as rare disorders, characterized by severe clinical expression early in life. However, it has become clear that these diseases are not as uncommon as originally suspected, that their clinical expression can sometimes be relatively mild, and that they are seen nearly as often in adolescents and adults as they are in infants and children.<sup>6-8</sup> In fact, the presentation of immunodeficiency may be so subtle that the diagnosis will be made only if the physician is alert to that possibility.

Patients with primary immunodeficiency diseases most often are recognized because of their increased susceptibility to infection, but they may also present with a variety of other clinical manifestations (Box 7-2). In fact, noninfectious manifestations, such as autoimmune disease, may be the first or the predominant clinical symptom of underlying immunodeficiency. Other immunodeficiency diseases may be diagnosed because of their known association with syndrome complexes.

**INFECTION**

An increased susceptibility to infection is the hallmark of the primary immunodeficiency diseases. In most patients, the striking clinical feature is the chronic or recurring nature of the infections rather than the fact that individual infections are unusually severe.<sup>1</sup> However, not all immunodeficient patients are diagnosed after recurrent infections. In some, the first infection may be sufficiently unusual to raise the question of immunodeficiency. For example, an infant who presents with infection caused by *P. jirovecii* or another opportunistic pathogen is likely to be immunodeficient even if it is his or her first recognized infection.

**AUTOIMMUNE/CHRONIC INFLAMMATORY DISEASE**

Immunodeficient patients can present with autoimmune or chronic inflammatory diseases. It is thought that the basic abnormality leading to immunodeficiency may also lead to faulty discrimination between self and non-self and, thus, susceptibility to develop an autoimmune disease. The manifestations of these disorders may be limited to a single target cell or organ (e.g. autoimmune hemolytic anemia, immune thrombocytopenia, autoimmune thyroiditis, inflammatory bowel



disease) or may involve a number of different target organs (e.g. vasculitis or systemic lupus erythematosus). The autoimmune and inflammatory diseases are more commonly seen in particular primary immunodeficiency diseases, most notably common variable immunodeficiency,<sup>9</sup> selective IgA deficiency, chronic mucocutaneous candidiasis<sup>10</sup> and deficiencies of early components (C1 through C4) of the classical complement pathway.<sup>11</sup>

Occasionally, a disorder that appears to be autoimmune in nature may in fact be due to an infectious agent. For example, the dermatomyositis that sometimes occurs in patients with X-linked agammaglobulinemia (XLA) is actually a manifestation of chronic enterovirus infection and not an autoimmune disease.

## SYNDROME COMPLEXES

Immunodeficiency can be seen as part of a constellation of signs and symptoms in a syndrome complex.<sup>12</sup> In fact, the recognition that a patient has a syndrome in which immunodeficiency occurs may allow a diagnosis of immunodeficiency to be made before there are any clinical manifestations of that deficiency (Table 7-1). For example, children with the DiGeorge syndrome are usually identified because of the neonatal presentation of congenital heart disease, hypocalcemia, or both. This should lead to T lymphocyte evaluation before the onset of infections. Similarly, a diagnosis of Wiskott-Aldrich syndrome can be made in young boys with eczema and thrombocytopenia even before the onset of infections.

### Cystic Fibrosis

Cystic fibrosis (CF) is one of the most common autosomal recessive disorders among white populations, occurring with an incidence of almost 1 in 3,000 live newborns.<sup>13</sup> The classic presentation of CF with chronic/recurrent sinopulmonary infections caused by *Pseudomonas* and *Staphylococcus*, diarrhea with malabsorption and failure to thrive, is easy to recognize. Newborn screening and new methods for diagnosis have led to the recognition of a broader clinical phenotype, including patients whose first or only manifestation is chronic/recurrent sinusitis.<sup>14,15</sup> The diagnosis of CF should be considered in any

patient with chronic/recurrent sinopulmonary infections, especially if *Pseudomonas*, *Staphylococcus* or *Burkholderia cepacia* is identified as a pathogen.

### Abnormalities of Airway Anatomy and Physiology

A variety of anatomic abnormalities may increase a child's susceptibility to upper and lower respiratory tract infections. Some, such as craniofacial anomalies involving the palate and the nose, may be readily apparent on physical examination. Others, such as bronchogenic cysts and extralobar pulmonary sequestrations, may be suspected when recurrent infections occur at a single anatomic site.<sup>16</sup> Unilateral otitis media and sinusitis in a young child should prompt an investigation for a nasal foreign body.

Abnormalities of airway muscle function may cause similar symptoms. Swallowing dysfunction with aspiration may be obvious in a child with cerebral palsy who coughs and gags when eating. More subtle clues are a history of drooling or dysarthria.

### Disorders of Ciliary Structure and Function

Primary ciliary dyskinesia (PCD) is a rare problem, estimated to occur with an incidence of less than 1 in 10,000 in the general population.<sup>17</sup> In most cases it is inherited as an autosomal recessive trait, but PCD is genetically and clinically heterogeneous. Affected individuals have chronic/recurrent rhinitis, otitis media, sinusitis, pneumonia and bronchiectasis that begin at an early age. In approximately half of the cases there are accompanying abnormalities of laterality such as situs inversus or heterotaxy, and complex congenital heart disease has been reported in approximately 10% of cases. Abnormal ciliary function of spermatozoa can cause infertility in males, and abnormal ciliary function in the fallopian tubes can cause ectopic pregnancy.

PCD can be caused by abnormalities of any of the ciliary structural proteins (inner or outer dynein arms, radial spokes or microtubules) or by disordered orientation of cilia on mucosal surfaces, preventing them from beating in a synchronized wave that clears mucus from the airways. Identification of genetic mutations may diagnose PCD despite normal ultrastructural findings by electron microscopy.<sup>17</sup>

TABLE  
7-1

Examples of Immunodeficiency Syndromes that May Increase Susceptibility to Sinopulmonary Infections

Syndrome	Clinical Presentation	Immunologic Abnormality	Other Contributing Factors	Genes
Ataxia telangiectasia	Ataxia, telangiectasia	Variable B and T lymphocyte dysfunction	Dysfunctional swallow with pulmonary aspiration	ATM
DiGeorge syndrome	Congenital heart disease, hypoparathyroidism, abnormal facies	Thymic hypoplasia or aplasia	Craniofacial anomalies including cleft palate; physiologic abnormalities including dysfunction of soft palate	22q11 deletion, 10p14 deletion, and others
Dysmotile cilia syndromes	Situs inversus, male infertility, ectopic pregnancy, upper and lower respiratory tract infections	None		30 different genes
Hyper-IgE syndromes	Coarse facies, eczematoid rash, retained primary teeth, bone fractures, pneumonia, chronic or recurrent cutaneous viral infections	Elevated serum IgE, eosinophilia		STAT3 (autosomal dominant) DOCK8 (autosomal recessive)
Wiskott-Aldrich syndrome	Thrombocytopenia, eczema	Variable B and T lymphocyte dysfunction		WAS

## Secondary Immunodeficiency

Immunodeficiency may occur secondary to other illnesses<sup>18</sup> or medications.<sup>19</sup> A variety of infections (including HIV, measles and Epstein-Barr virus [EBV]) may cause either temporary or long-lived abnormalities of humoral and/or cell-mediated immunity. Malnutrition or malabsorption can cause hypogammaglobulinemia and impaired cell-mediated immunity. A number of medications, most notably corticosteroids and chemotherapeutic agents, are immunosuppressive; phenytoin and other anticonvulsants can cause IgA deficiency and rarely panhypogammaglobulinemia. Posttraumatic splenectomy, or the ‘autosplenectomy’ that occurs at an early age in sickle cell anemia, leads to an increased risk of sepsis. Susceptibility to specific infections is determined by the cause of the secondary immunodeficiency; that is, patients with acquired deficiency of humoral immunity are at highest risk for infections with encapsulated bacteria and enteroviruses, whereas patients with acquired deficiency of cell-mediated immunity are at risk for infection by a wide variety of bacterial, fungal and viral pathogens.

## Laboratory Tests for Underlying Disorders

### IMMUNODEFICIENCY

Although the clinician can suspect immunodeficiency after a careful review of the history and physical examination, specific diagnoses are rarely evident without use of the laboratory. However, the types of infections and other symptoms should help to focus the laboratory work-up on specific parts of the immune system (Table 7-2). For example, patients with antibody deficiency typically have sinopulmonary infections as a prominent presenting feature.<sup>20</sup> Deficiency of cell-mediated immunity predisposes individuals to develop infections caused by *P. jirovecii*, other fungi and a variety of viruses.<sup>21</sup> Abnormalities of phagocytic function should be suspected when patients have recurrent skin infections or visceral abscesses.<sup>22</sup> Patients with complement deficiency most often present with bacterial sepsis or immune complex-mediated diseases.<sup>23</sup> Patients who are deficient in mannose binding lectin may have recurrent respiratory tract infections, but only in the first several years of life.<sup>24</sup>

Screening tests that should be performed in almost all patients include a complete blood count with differential,

and measurement of serum immunoglobulins. Other tests should be guided by the clinical features of the patient (Table 7-3). Finally, whenever primary immunodeficiency is suspected, consideration must also be given to secondary causes of immunodeficiency, including infection with HIV or EBV, therapy with antiinflammatory medications (e.g. corticosteroids) and other underlying illnesses (e.g. lymphoreticular neoplasms).

For individuals who have a syndrome complex that includes increased susceptibility to infection as well as atopic disease (e.g. Wiskott-Aldrich syndrome, IPEX, hyper-IgE syndromes<sup>25</sup>), measurement of mean platelet volume and *FOXP3* expression, and mutation analysis for the relevant genes (*WAS* for Wiskott-Aldrich syndrome; *FOXP3* for IPEX; *STAT3* and *DOCK8* for hyper-IgE syndrome) should be considered.

### EXAMINATION OF THE PERIPHERAL BLOOD SMEAR

The complete blood count with examination of the blood smear is an inexpensive and readily available test that provides important diagnostic information relating to a number of immunodeficiency diseases. Neutropenia most often occurs secondary to immunosuppressive drugs, infection, malnutrition or autoimmunity but may be a primary problem (congenital or cyclic neutropenia). In contrast, persistent neutrophilia is characteristic of leukocyte adhesion molecule deficiency,<sup>26</sup> and abnormal cytoplasmic granules may be seen in the peripheral blood smear of patients with Chediak-Higashi syndrome.<sup>27</sup>

The blood is predominantly a ‘T cell organ’; that is, the majority (50–70%) of peripheral blood lymphocytes are T cells, whereas only 5% to 15% are B cells. Therefore lymphopenia is usually a feature of T cell or combined immunodeficiency disorders such as DiGeorge syndrome or severe combined immunodeficiency disease.

Thrombocytopenia may occur as a secondary (usually autoimmune) manifestation of immunodeficiency but is often a presenting manifestation of the Wiskott-Aldrich syndrome. A unique finding in the latter group of patients is an abnormally small platelet (and lymphocyte) volume,<sup>28</sup> a measurement that is easily made with automated blood counters. Confirmation of the diagnosis should be made by mutation analysis.

Examination of red blood cell morphology can yield clues about splenic function. Howell-Jolly bodies may be visible in peripheral blood in cases of splenic dysfunction or asplenia.<sup>29</sup> However, the converse is not always true, and the absence of

TABLE 7-2 Patterns of Illness Associated with Primary Immunodeficiency

Disorder	ILLNESSES	
	Infection	Other
Antibody	Sinopulmonary (pyogenic, encapsulated bacteria) Gastrointestinal (enteroviruses, <i>Giardia</i> )	Autoimmune disease (autoantibodies, inflammatory bowel disease)
Cell-mediated immunity	Pneumonia (pyogenic bacteria, <i>Pneumocystis jirovecii</i> , viruses) Gastrointestinal (viruses) Skin, mucous membranes (fungi)	
Phagocytosis	Skin, reticuloendothelial system, abscesses ( <i>Staphylococcus</i> , enteric bacteria, fungi, mycobacteria)	
Complement	Sepsis and other blood-borne encapsulated bacteria ( <i>Streptococcus</i> , <i>Pneumococcus</i> , <i>Neisseria</i> )	Autoimmune disease (systemic lupus erythematosus, glomerulonephritis)

**TABLE 7-3** Screening Tests for Underlying Disorders

Suspected Abnormality	Diagnostic Tests
Antibody	Quantitative immunoglobulins (IgG, IgA, IgM) Antibody response to immunization
Cell-mediated immunity	Lymphocyte count T lymphocyte enumeration (CD3, CD4, CD8) T lymphocyte function in vitro: proliferation to mitogens and antigens Human immunodeficiency virus serology and viral load
Complement	Total hemolytic complement (CH <sub>50</sub> )
Phagocytosis	Neutrophil count

Howell-Jolly bodies does not ensure that splenic function is normal.

### EVALUATION OF HUMORAL IMMUNITY

Measurement of serum immunoglobulins is an important screening test to detect immunodeficiency for three reasons: (1) more than 80% of patients diagnosed with a primary disorder of immunity will have abnormalities of serum immunoglobulins; (2) immunoglobulin measurements yield indirect information about several aspects of the immune system because immunoglobulin synthesis requires the coordinated function of B and T lymphocytes and antigen-presenting cells; and (3) the measurement of serum immunoglobulin levels is readily available, reliable and inexpensive. Neither serum protein electrophoresis nor immunoelectrophoresis is sufficiently sensitive or quantitative to substitute for quantitative measurements of serum IgG, IgA and IgM levels. This will identify patients with panhypogammaglobulinemia as well as those with deficiencies of an individual immunoglobulin class, such as selective IgA deficiency. Interpretation of results must be made in view of the marked variations in normal immunoglobulin levels with age,<sup>30</sup> therefore age-related normal values must always be used for comparison. Different reference ranges are necessary in the first year of life for very low birth-weight, premature infants.<sup>31</sup>

It is almost always important to assess the ability to make antibody to vaccines in addition to measuring immunoglobulin levels. Live viral (e.g. oral polio, measles, mumps, rubella, varicella) and bacterial (e.g. bacille Calmette-Guérin) vaccines should never be used for the evaluation of suspected immunodeficiency because they may cause disseminated infection in an immunocompromised host. Antibody levels generated in response to childhood immunization with tetanus toxoid, pneumococcal or *Hemophilus influenzae* polysaccharide/protein conjugate vaccines are usually the most convenient to measure. In children over the age of 18 to 24 months it is also important to assess antibody responses to polysaccharide antigens, because these responses may be deficient in some patients who can respond normally to protein and polysaccharide/protein conjugate antigens.<sup>32</sup> For this purpose, antibody can be measured in response to immunization with the 23-valent pneumococcal capsular polysaccharide vaccine. Alternatively, because the ABO blood group antigens are polysaccharides, quantifying isoagglutinin titers (usually of the IgM class) can

assess antipolysaccharide antibody. However, the value of the latter test in the young child is limited because many normal children do not have significant isoagglutinin titers.<sup>33</sup> There are a few patients who make normal antibody responses to vaccines but do not have long-term immunologic memory. These individuals can be identified only by re-checking antibody levels 6 to 12 months after immunization. Most patients with hypogammaglobulinemia and impaired antibody responses will have common variable immunodeficiency,<sup>9</sup> a syndrome for which no genetic etiology can be established in the vast majority of cases. The diagnosis can be made only after excluding other primary (e.g. transient hypogammaglobulinemia of infancy<sup>34</sup> in children less than 3 years old, and X-linked agammaglobulinemia in males) and secondary (e.g. protein-losing enteropathy) causes. Males with panhypogammaglobulinemia and absent B lymphocytes on flow cytometry should be tested for mutations in the *BTK* gene, which if present would confirm the diagnosis of X-linked agammaglobulinemia.

Selective deficiencies of IgG subclasses have been described. However, the clinical significance of an IgG subclass deficiency in the presence of normal antibody responses to protein and polysaccharide antigens is unclear, and therefore IgG subclass measurements are rarely useful.<sup>35</sup>

### EVALUATION OF CELL-MEDIATED IMMUNITY

Testing for defects of cell-mediated immunity is relatively difficult because of the lack of good screening tests. Lymphopenia is suggestive of T lymphocyte deficiency because T lymphocytes constitute the majority (50–70%) of peripheral blood mononuclear cells. However, lymphopenia is not always present in patients with T lymphocyte functional defects. Similarly, the lack of a thymus silhouette on chest radiography is rarely helpful in the evaluation of T lymphocyte disorders because the thymus of normal children may rapidly involute after stress and provide the appearance of thymic hypoplasia.

Information about the T cell compartment may be obtained by subset analysis of peripheral blood T lymphocytes by flow cytometry.<sup>36</sup> Patients with severe combined immunodeficiency and DiGeorge syndrome generally have decreased numbers of CD3, CD4 and CD8 T lymphocytes, whereas patients infected with HIV have a selective loss of CD4 lymphocytes. Further analysis of T cell numbers can evaluate expression of the  $\alpha/\beta$  or  $\gamma/\delta$  T cell receptor, and the distribution of CD45RA (naïve) and CD45RO (memory) subsets. With increasing availability of antibodies specific to cell surface proteins, subtle defects associated with deficiencies of specific subsets of T cells are being described, such as deficiencies of regulatory T cells in IPEX.<sup>3</sup>

Because enumeration does not indicate function, assessment of the in vitro proliferative response of T cells to mitogens (phytohemagglutinin A, concanavalin A) or antigens (tetanus toxoid, candida) or other stimuli is essential.<sup>37</sup> Delayed-type hypersensitivity (DTH) skin testing with a panel of antigens can be used to screen for cell-mediated immune function but there are significant limitations to its use, including the lack of standardized reagents, and false-negative results due to lack of prior exposure to antigen, young age and difficulties with intradermal injection.<sup>38–40</sup>

Individuals who have low numbers of T lymphocytes and/or impaired function should be evaluated for a combined immunodeficiency disorder. Flow cytometry is used to assess the number and percentage of T, B and NK cells in peripheral

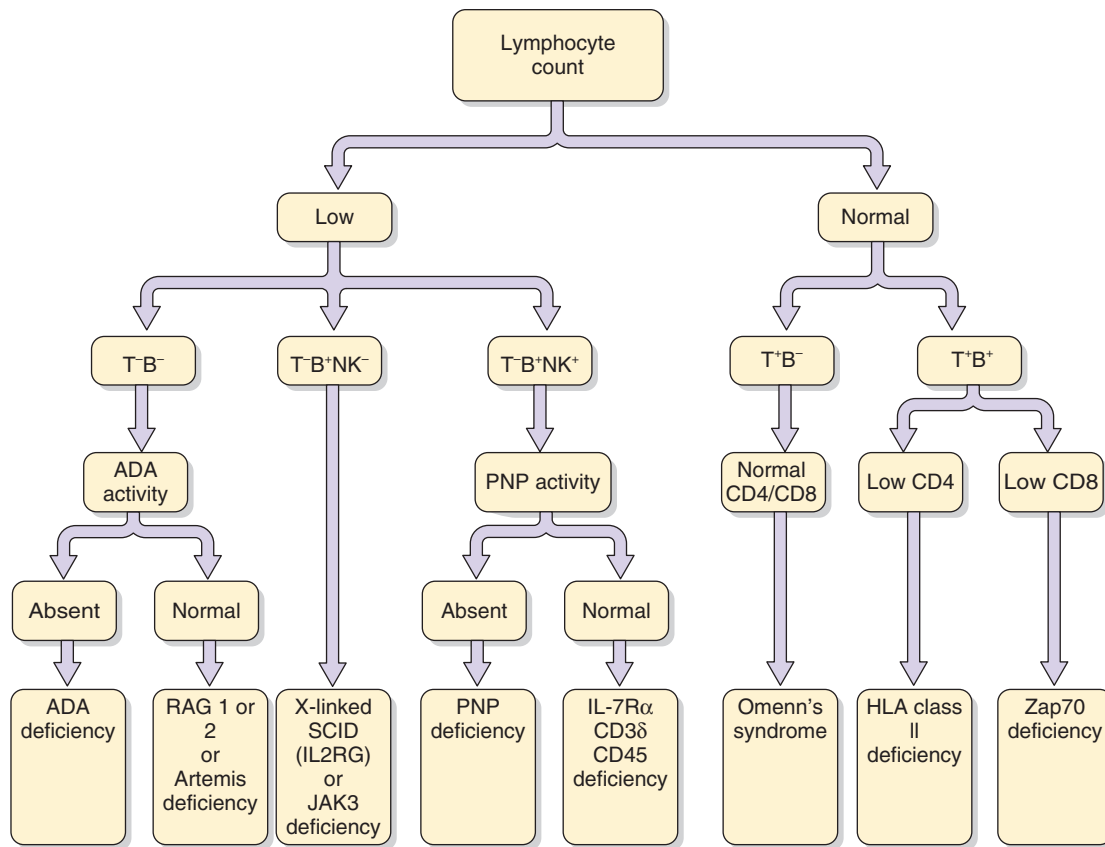

**Figure 7-1** Algorithm for evaluating the most common deficiencies of cell-mediated immunity. ADA – Adenosine deaminase; PNP – purine nucleoside phosphorylase.

blood, and those results can guide the selection of molecular diagnostics (Figure 7-1). Individuals with low T lymphocyte counts but normal numbers of B and NK cells, especially in the presence of congenital heart disease, facial dysmorphism, hypocalcemia, abnormal speech or learning disorders should be tested with fluorescent in situ hybridization to detect a 22q11 deletion associated with DiGeorge syndrome.<sup>41</sup> This will identify the majority of such cases, but a comparative genomic hybridization microarray may be needed to detect very small deletions at that locus or deletions at other sites, and should be pursued if the clinical suspicion is high.

### EVALUATION OF THE COMPLEMENT SYSTEM

Most of the genetically determined deficiencies of complement can be detected with the total serum hemolytic complement (CH<sub>50</sub>) assay.<sup>42</sup> Because this assay depends on the functional integrity of all of the components of the classical complement pathway (C1 through C9), a genetic deficiency of any of these components leads to a marked reduction of the CH<sub>50</sub>. Consumption of components (e.g. in autoimmune disease) generally reduces, but does not eliminate, complement activity. Mannose binding lectin can be measured by ELISA. Alternative pathway deficiencies (e.g. factor H, factor I and properdin) are extremely rare; they may be suspected if the CH<sub>50</sub> is in the low range of normal and the serum C3 level is low. AH<sub>50</sub> is an assay of alternative pathway complement activity that is helpful. The final identification of the specific complement component that

is deficient usually rests on both functional and immunochemical tests, and specific assays have been developed for each of the individual components.

### EVALUATION OF PHAGOCYtic CELLS

Evaluation of phagocytic cells usually entails assessment of both their number and function. Disorders such as congenital agranulocytosis or cyclic neutropenia that are characterized by a deficiency in phagocytic cell number can be easily detected by evaluating a white blood cell count and differential. Beyond that, assessment of phagocytic cell function is relatively specialized because it depends on a variety of in vitro assays, including measurement of directed cell motility (chemotaxis), ingestion (phagocytosis) and intracellular killing (bactericidal activity).<sup>43</sup> The most common of the phagocyte function disorders, chronic granulomatous disease, can be diagnosed by the nitroblue tetrazolium (NBT) dye test<sup>44</sup> or by using the flow cytometric dihydrorhodamine (DHR)<sup>45</sup> test, both of which measure the oxidative metabolic response of neutrophils and monocytes. A western blot or molecular analysis can confirm the diagnosis and identify the pathogenic mutation in the NADPH oxidase pathway (gp91, p22, p47 or p67). Patients with gp91 deficiency generally have a more severe course.

#### Evaluation of Cilia

For suspected ciliary dyskinesia, ciliary structure and function must be assessed. Structure is assessed by electron microscopy



of tissue obtained from the nasal mucosa, tonsils, adenoids or bronchial mucosa. Because tobacco smoke, other pollutants and infection may cause secondary abnormalities of cilia, it is sometimes difficult to find an appropriate tissue to sample. The microscopic examination should look for the presence of an anatomic defect that is consistent from cilia to cilia, such as the absence of dynein arms, and assess the orientation of cilia on the epithelium. With secondary causes, the structural abnormalities vary from cilia to cilia.<sup>46</sup> At the same time that tissue is obtained for electron microscopy, epithelial cell brushings from the nasal turbinates or bronchi can be examined for ciliary waveform and beat frequency. Assessments of mucociliary clearance can be made by placing a small particle of saccharin on the anterior portion of the middle turbinate and measuring the time until the patient tastes the saccharin.<sup>47</sup> For this test, the subject must sit quietly without sniffing or sneezing, and it is therefore difficult to perform in young children. A sweet taste should be evident within 1 hour in normal subjects, but the test has a very high rate of false-positive results. In individuals with a high suspicion for one of the ciliary defects, genetic screening for one of the mutations may be necessary.

### Cystic Fibrosis

In most cases, the diagnosis of CF can be made by measuring the chloride concentration in sweat after iontophoresis of pilocarpine.<sup>48</sup> A minimum acceptable volume or weight of sweat must be collected to ensure an average sweat rate of greater than 1 g/m<sup>2</sup>/min, and the diagnosis can be made with certainty if the sweat chloride concentration is greater than 60 mmol/L. However, this test may be falsely negative, especially among those patients who have an atypical clinical presentation. If the clinical suspicion of CF is high, especially in the absence of some of the more common CF symptoms, other useful diagnostic tests include mutation analysis of the CF transmembrane conductance regulator (CFTR) gene and/or measurement of potential differences across the nasal epithelium (nasal PD). The genetic test is commercially available; the measurement of nasal PD is not widely available and should still be considered a research tool.

### Evaluation for Human Immunodeficiency Virus and Other Immunosuppressive Virus Infections

Many techniques for the diagnosis of viral infection focus on the serologic detection of antibodies to viral proteins. There are, however, several problems with sole reliance on antibody detection techniques. First, antibody tests will not detect infection in patients during the interval between the time of infection and seroconversion. For HIV infections, 95% of individuals will seroconvert within 6 months of infection, although a so-called 'window period' of as long as 35 months has been reported.<sup>49,50</sup> Second, if a virus induces immunodeficiency, it may inhibit the production of antiviral antibodies.<sup>51</sup> Thus, in a patient with known or suspected immunodeficiency, viral cultures as well as tests to detect viral antigens and nucleic acids should be performed in addition to serologic tests.<sup>52</sup>

## Molecular Diagnostics

The molecular basis is known for the majority of recognized primary immunodeficiency diseases. Multiple gene defects underlying certain diseases (e.g. severe combined immunodeficiency disease, chronic granulomatous disease, and hyper-IgE

### BOX 7-3 KEY CONCEPTS

#### Identification of Underlying Disorders in Children with Recurrent Infections

**Children with chronic/recurrent infections may have one of the following underlying defects**

- Allergy
- Immunodeficiency (primary or secondary)
- Cystic fibrosis
- Ciliary dysmotility
- Localized abnormalities of anatomy or physiology

**Immunodeficient patients present with a variety of symptoms**

- Increased susceptibility to infection
- Autoimmune or inflammatory disorders
- Syndrome complexes

**Recurrent infections at a single anatomic site should prompt investigation of the anatomy and physiology of that site**

syndromes) have been identified. Determination of the genotype should be sought whenever possible to confirm the clinical diagnosis. In some cases it may provide critical prognostic information (e.g. the significant risk of malignancy when *DOCK8*, but not *STAT3*, is the cause of hyper-IgE). In other cases, it may lead to a specific therapy (e.g. enzyme replacement therapy, bone marrow transplantation or gene therapy). In all cases, knowing the genotype allows for genetic counseling and carrier testing, as well as prenatal or early post-natal diagnosis.

There are two general approaches to molecular diagnosis. A specific combination of clinical and laboratory features will lead to an almost certain diagnosis (e.g. severe hypogammaglobulinemia and absent B cells in a male infant is X-linked agammaglobulinemia until proven otherwise) or a paradigm exists to guide molecular diagnostic testing (e.g. the pattern of T, B and NK cell deficiency guides the evaluation for SCID, see [Figure 7-1](#)). Sometimes, an unusual phenotype or a usual phenotype whose suspected gene defect cannot be identified will lead to an unbiased genomic analysis (whole genome single nucleotide polymorphism or whole exome sequence) and identification of a disease-causing mutation.

## Conclusions

The majority of children with recurrent respiratory tract infections will have environmental risk factors such as exposure to daycare or cigarette smoke, or are atopic with associated problems with allergies. It is the task of the allergist to identify individuals who are most likely to have an underlying deficiency of host defense and to perform appropriate screening tests for such disorders. Early identification is critical for optimal clinical management and genetic counseling ([Box 7-3](#)).

## Helpful Website

Immune Deficiency Foundation website ([www.primaryimmune.org](http://www.primaryimmune.org))

The complete reference list can be found on the companion Expert Consult website at <http://www.expertconsult.inkling.com>.

## KEY REFERENCES

1. Bonilla FA, Khan DA, Ballas ZK, Chinen J, Frank MM, Hsu JT, et al. Practice parameter for the diagnosis and management of primary immunodeficiency. *J Allergy Clin Immunol* 2015 (in press).
6. Al-Herz W, Bousfiha A, Casanova JL, Chatila T, Conley ME, Cunningham-Rundles C, et al. Primary immunodeficiency diseases: an update on the classification from the international union of immunological societies expert committee for primary immunodeficiency. *Front Immunol* 2014;5:162.
7. Ochs HD, Hagin D. Primary immunodeficiency disorders: general classification, new molecular insights, and practical approach to diagnosis and treatment. *Ann Allergy Asthma Immunol* 2014;112:489–95.
9. Resnick ES, Cunningham-Rundles C. The many faces of the clinical picture of common variable immune deficiency. *Curr Opin Allergy Clin Immunol* 2012;12:595–601.
15. Wang X-J, Maylan B, Leopold DA, Kim J, Rubenstein R, Togias A, et al. Mutation in the gene responsible for cystic fibrosis and predisposition to chronic rhinosinusitis in the general population. *JAMA* 2000;284:1814–19.
25. Freeman AF, Holland SM. Clinical manifestations of hyper IgE syndromes. *Dis Markers* 2010;29:123–30.
34. Van Winkle RC, Hauck WW, McGeady SJ. Phenotypic parameters predict time to normalization in infants with hypogammaglobulinemia. *J Clin Immunol* 2013;33:1336–40.
36. Shearer WT, Rosenblatt HM, Gelman RS, Oyomopito R, Plaeger S, Stiehm ER, et al. Lymphocyte subsets in healthy children from birth through 18 years of age: the Pediatric AIDS Clinical Trials Group P1009 study. *J Allergy Clin Immunol* 2003;112:973–80.
41. McDonald-McGinn DM, Sullivan KE. Chromosome 22q11.2 deletion syndrome (DiGeorge syndrome/velocardiofacial syndrome). *Medicine (Baltimore)* 2011;90:1–18.
43. Elloumi HZ, Holland SM. Diagnostic assays for chronic granulomatous disease and other neutrophil disorders. *Methods Mol Biol* 2007;412:505–23.

## REFERENCES

- Bonilla FA, Khan DA, Ballas ZK, Chinen J, Frank MM, Hsu JT, et al. Practice parameter for the diagnosis and management of primary immunodeficiency. *J Allergy Clin Immunol* 2015 (in press).
- Rachelefsky GS, Katz RM, Siegel SC. Chronic sinus disease with associated reactive airway disease in children. *Pediatrics* 1984;73:526–9.
- Verbsky JW, Chatila TA. Immune dysregulation, polyendocrinopathy, enteropathy, X-linked (IPEX) and IPEX-related disorders: an evolving web of heritable autoimmune diseases. *Curr Opin Pediatr* 2013;25:708–14.
- Kaufman HS, Hobbs JR. Immunologic deficiencies in an atopic population. *Lancet* 1970;2:1061–3.
- Plebani A, Monafò V, Ugazio AG, Monti C, Avanzini MA, Massinn P, et al. Comparison of the frequency of atopic diseases in children with severe and partial IgA deficiency. *Int Arch Allergy Appl Immunol* 1987;82:485–6.
- Al-Herz W, Bousifha A, Casanova JL, Chatila T, Conley ME, Cunningham-Rundles C, et al. Primary immunodeficiency diseases: an update on the classification from the international union of immunological societies expert committee for primary immunodeficiency. *Front Immunol* 2014;5:162.
- Ochs HD, Hagin D. Primary immunodeficiency disorders: general classification, new molecular insights, and practical approach to diagnosis and treatment. *Ann Allergy Asthma Immunol* 2014;112:489–95.
- Nelson KS, Lewis DB. Adult-onset presentations of genetic immunodeficiencies: genes can throw slow curves. *Curr Opin Infect Dis* 2010;23:359–64.
- Resnick ES, Cunningham-Rundles C. The many faces of the clinical picture of common variable immune deficiency. *Curr Opin Allergy Clin Immunol* 2012;12:595–601.
- Lanternier F, Cypowij S, Picard C, Bustamante J, Lortholary O, Casanova JL, et al. Primary immunodeficiencies underlying fungal infections. *Curr Opin Pediatr* 2013;25:736–47.
- Barilla-LaBarca ML, Atkinson JP. Rheumatic syndromes associated with complement deficiency. *Curr Opin Rheumatol* 2003;15:55–60.
- Ming JE, Stiehm ER, Graham JM Jr. Syndromic immunodeficiencies: genetic syndromes associated with immune abnormalities. *Crit Rev Clin Lab Sci* 2003;40:587–642.
- Davies JC, Alton EW, Bush A. Cystic fibrosis. *Br Med J* 2007;335:1255–9.
- Wiatrak BJ, Meyer CM III, Cottin RT. Cystic fibrosis presenting with sinus disease in children. *Am J Dis Child* 1993;147:258–60.
- Wang X-J, Maylan B, Leopold DA, Kim J, Rubenstein R, Trogias A, et al. Mutation in the gene responsible for cystic fibrosis and predisposition to chronic rhinosinusitis in the general population. *JAMA* 2000;284:1814–19.
- Winters WD, Effmann EL. Congenital masses of the lung: prenatal and postnatal imaging evaluation. *J Thorac Imaging* 2001;16:196–206.
- Lucas JS, Burgess A, Mitchison HM, Moya E, Williamson M, Hogg C, on behalf of the National PCD Service, UK. Diagnosis and management of primary ciliary dyskinesia. *Arch Dis Child* 2014;99:850–6.
- Bonilla FA. Secondary immunodeficiency due to underlying disease states, environmental exposures, and miscellaneous causes. In: UpToDate, Stiehm ER, editor. UpToDate, Waltham, MA. Accessed on 18 February 2015.
- Ballow M, Fleisher TA. Secondary immunodeficiency induced by drugs and biologic therapies. In: UpToDate, Stiehm ER, editor. UpToDate, Waltham, MA. Accessed on 18 February 2015.
- Ochs HD, Smith CI. X-linked agammaglobulinemia: a clinical and molecular analysis. *Medicine* 1996;75:287–99.
- Buckley RH. Primary cellular immunodeficiencies. *J Allergy Clin Immunol* 2002;109:747–57.
- Rosenzweig SD, Holland S. Phagocyte immunodeficiencies and their infections. *J Allergy Clin Immunol* 2004;113:620–6.
- Walport MJ. Complement. *N Engl J Med* 2001;344:1058–66.
- Koch A, Melbye M, Sorensen P, Homoe P, Madsen HO, Molbak K, et al. Acute respiratory tract infections and mannose-binding lectin insufficiency during early childhood. *JAMA* 2001;285:1316–21.
- Freeman AF, Holland SM. Clinical manifestations of hyper IgE syndromes. *Dis Markers* 2010;29:123–30.
- Etzioni A. Defects in the leukocyte adhesion cascade. *Clin Rev Allergy Immunol* 2010;38:54–60.
- Introne W, Boissy RE, Gahl WA. Clinical, molecular, and cell biological aspects of Chediak-Higashi syndrome. *Mol Genet Metab* 1999;68:283–303.
- Corash L, Shafer B, Blaese RM. Platelet-associated immunoglobulin, platelet size, and the effect of splenectomy in the Wiskott-Aldrich syndrome. *Blood* 1985;65:1439–43.
- Lammers AJ, de Porto AP, Bennink RJ, van Leeuwen EM, Biemond BJ, Goslings JC, et al. Hyposplenism: comparison of different methods for determining splenic function. *Am J Hematol* 2012;87:484–9.
- Jolliff CR, Cost KM, Stivri PC, Grossman PP, Nolte CR, Franco SM, et al. Reference intervals for serum IgG, IgA, IgM, C3 and C4 as determined by rate nephelometry. *Clin Chem* 1982;28:126–8.
- Ballow M, Cates KL, Rowe JC, Goetz C, Desbonnet C. Development of the immune system in very low birth weight (less than 1500 g) premature infants: concentrations of plasma immunoglobulins and patterns of infections. *Pediatr Res* 1986;20:899–904.
- Ruuskanen O, Nurkka A, Helminen M, Viljanen MK, Käyhty H, Kainulainen L. Specific antibody deficiency in children with recurrent respiratory infections: a controlled study with follow-up. *Clin Exp Immunol* 2013;172:238–44.
- Auf de Maur C, Hodel M, Nydegger UE, Rieben R. Age dependency of ABO histo-blood group antibodies: reexamination of an old transfusion dogma. *Transfusion* 1993;33:915–18.
- Van Winkle RC, Hauck WW, McGeedy SJ. Phenotypic parameters predict time to normalization in infants with hypogammaglobulinemia. *J Clin Immunol* 2013;33:1336–40.
- Buckley RH. Immunoglobulin G subclass deficiency: fact or fancy? *Curr Allergy Asthma Rep* 2002;2:356–60.
- Shearer WT, Rosenblatt HM, Gelman RS, Oyo-mopito R, Plaeger S, Stiehm ER, et al. Lymphocyte subsets in healthy children from birth through 18 years of age: the Pediatric AIDS Clinical Trials Group P1009 study. *J Allergy Clin Immunol* 2003;112:973–80.
- Folds JD, Schmitz JL. Clinical and laboratory assessment of immunity. *J Allergy Clin Immunol* 2003;111(Suppl. 2):S702–11.
- Centers for Disease Control and Prevention. Anergy skin testing and preventive therapy for HIV-infected persons: revised recommendations. *MMWR Morb Mortal Wkly Rep* 1997;46(RR-15):1–19.
- Gordon EH, Krouse HA, Kinney JL, Stiehm ER, Klaustermeyer WB. Delayed cutaneous hypersensitivity in normals: choice of antigens and comparison to in vitro assays of cell-mediated immunity. *J Allergy Clin Immunol* 1983;72:487–94.
- Rosenstreich DL. Evaluation of delayed hypersensitivity: from PPD to poison ivy. *Allergy Proc* 1993;14:395–400.
- McDonald-McGinn DM, Sullivan KE. Chromosome 22q11.2 deletion syndrome (DiGeorge syndrome/velocardiofacial syndrome). *Medicine (Baltimore)* 2011;90:1–18.
- Frank MM. Complement disorders and hereditary angioedema. *J Allergy Clin Immunol* 2010;125(2 Suppl. 2):S262–71.
- Elloumi HZ, Holland SM. Diagnostic assays for chronic granulomatous disease and other neutrophil disorders. *Methods Mol Biol* 2007;412:505–23.
- Baehner RL, Nathan DG. Quantitative nitroblue tetrazolium test in chronic granulomatous disease. *N Engl J Med* 1968;278:971–6.
- Roesler J, Emmendorffer A. Diagnosis of chronic granulomatous disease. *Blood* 1991;78:1387–9.
- Carson JL, Collier AM, Hu SS. Acquired ciliary defects in nasal epithelium of children with acute viral upper respiratory infections. *N Engl J Med* 1985;312:463–8.
- Stanley P, MacWilliam L, Greenstone M, Mackay I, Cole P. Efficacy of a saccharin test for screening to detect abnormal mucociliary clearance. *Br J Dis Chest* 1984;78:62–5.
- Rosenstein BJ, Cutting GR, for the Cystic Fibrosis Foundation Consensus Panel. The diagnosis of cystic fibrosis: a consensus statement. *J Pediatr* 1998;132:589–95.
- Horsburgh CH Jr, Jason J, Longini IM Jr, Mayer KH, Schochetman G, Rutherford GW, et al. Duration of human immunodeficiency virus infection before detection of antibody. *Lancet* 1989;2:637–40.
- Imagawa DT, Lee MH, Wolinsky SM, Sano K, Morales F, Kwok S, et al. Human immunodeficiency virus type 1 infection in homosexual men who remain seronegative for prolonged periods. *N Engl J Med* 1989;320:1458–62.
- Saulsbury FT, Wykoff RE, Boyle RJ. Transfusion-acquired human immunodeficiency virus infection in twelve neonates: epidemiologic, clinical and immunologic features. *Pediatr Infect Dis J* 1987;6:544–9.
- Cornett JK, Kirn TJ. Laboratory diagnosis of HIV in adults: a review of current methods. *Clin Infect Dis* 2013;57:712–18.

# Antibody Deficiency

FRANCISCO A. BONILLA

## KEY POINTS

- A clinician must maintain an index of suspicion for immunodeficiency when confronted with patients with infections considered unusual with respect to frequency, severity, response to treatment, or organism.
- The possibility of antibody deficiency in particular should be considered when the history includes pyogenic upper and lower respiratory tract infections.
- Early diagnosis is critical for reducing morbidity and mortality rates for immunodeficiency diseases.
- To provide the most efficient and complete approach to diagnosis and management, referral to a clinical immunology specialist is indicated where there is clear evidence for, or suspicion of, antibody or other immunodeficiency syndrome.
- Intravenous or subcutaneous immunoglobulin replacement therapy and antibiotic prophylaxis are the main modalities for management of antibody deficiency disorders.
- With intravenous immunoglobulin (IVIG) and antibiotics, many patients with agammaglobulinemia or hypogammaglobulinemia may lead normal or near-normal lives.

Primary immunodeficiency diseases arise from inherited or spontaneous genetic lesions affecting immune system function. These may be subdivided into defects of adaptive and innate immunity. Defects of adaptive immunity are further subdivided into humoral, cellular and combined (humoral and cellular) immunodeficiencies resulting mainly from lymphocyte dysfunction. Disorders of innate immunity result from defects of phagocytes, the complement system or signaling systems such as Toll-like receptors.<sup>1,2</sup> Humoral immunodeficiencies, also called antibody deficiencies, are characterized by low serum levels of one or more immunoglobulin classes and/or relative impairment of antibody responses to antigen challenge. This may arise as the result of a defect intrinsic to the antibody-producing cells (B cells) or of a failure of communication between T cells and B cells (T cell help for antibody production). Cell-mediated immunity is intact.

The most common complications of humoral immunodeficiency are recurrent bacterial infections of the upper and lower respiratory tract.<sup>3,4</sup> In severe forms of antibody deficiency, repeated lung infections lead to bronchiectasis.<sup>5</sup> In these patients, airway and systemic inflammation are exaggerated in comparison to patients having bronchiectasis associated with other (non-immune deficient) processes. Chronic lung disease and diminished pulmonary function and reserve account for a large proportion of the morbidity and impaired quality of life.<sup>5</sup>

Other than the respiratory tract, organ systems frequently infected include the gastrointestinal tract, skin, and the central nervous and musculoskeletal systems. These infections are generally caused by the same organisms virulent in immunocompetent hosts, predominantly encapsulated bacteria such as *S. pneumoniae*, *H. influenzae*, *S. aureus* and *N. meningitidis*. Viral infections are usually cleared normally by these patients, although some enteric viruses (particularly echoviruses) may cause severe disease. Antibody deficient individuals have a higher frequency of recurrence with the same agents, since they do not produce neutralizing antibodies or B cell memory. Additional infectious diseases may be associated with particular syndromes.<sup>1,2</sup>

The most severely affected patients have frequent pneumonias and other invasive bacterial infections and frequent severe viral infections. Treatment-resistant recurrent otitis media and sinusitis are also frequently seen. There are no validated clinical criteria for predicting which children with recurrent otitis media or sinusitis or pneumonias will have an identifiable immunologic defect. A high index of suspicion for antibody deficiency should be maintained in cases of recurrent, refractory or severe respiratory and other infections.

Estimates of the incidence and prevalence of immunodeficiency overall range from about 1:10 000–1:2000.<sup>6</sup> These estimates are based on survey and registry data; there are no prospective studies to measure incidence formally. Table 8-1 contains a classification of humoral immunodeficiencies according to known gene defects, as well as clinically defined entities.

## X-LINKED AGAMMAGLOBULINEMIA

Ogden Bruton published the classic description of this disorder in 1952; therefore this condition is often called 'Bruton's agammaglobulinemia'.<sup>7</sup> It is caused by a defect in a signal transducing protein known as Bruton's tyrosine kinase (BTK).<sup>8</sup> BTK is expressed in B cells, monocytes, macrophages, mast cells, erythroid cells and platelets; it transduces signals from the B cell immunoglobulin receptor. Without BTK, B cell development is impeded at an early stage.

Only males are affected, and they are often asymptomatic during infancy. In this period, they are protected by maternal antibodies acquired during gestation. After birth, maternal IgG gradually disappears, and infectious complications usually begin by the age of 9 to 18 months. The absence of tonsils or palpable lymph nodes is notable on examination. Laboratory investigation reveals absent or very low serum levels of immunoglobulins and B cells.

Despite normal cellular immunity, patients with X-linked agammaglobulinemia (XLA) are prone to certain viral infections, including chronic enteroviral meningoencephalitis and vaccine-associated paralytic poliomyelitis. Additional infections described in these patients include mycoplasma or ureaplasma



**TABLE 8-1**  
**Classification of Humoral Immunodeficiencies**

Disease	Gene
<b>KNOWN GENETIC BASIS</b>	
X-linked (Bruton's) agammaglobulinemia (XLA), Bruton's tyrosine kinase	<i>BTK</i>
Autosomal agammaglobulinemia:	
Immunoglobulin M constant region (C $\mu$ )	<i>IGHM</i>
Signal transducing molecule Ig $\alpha$	<i>CD79A</i>
Signal transducing molecule Ig $\beta$	<i>CD79B</i>
Surrogate light chain component $\lambda$ 5	<i>IGLL1</i>
B cell linker protein	<i>BLNK</i>
PI3 kinase regulatory subunit 1	<i>PIK3R1</i>
Transcription factor 3	<i>TCR3</i>
Translocation of LRRC8	<i>LRRC8</i>
Hyper-IgM syndrome (HIM)	
X-linked (XHIM, HIM1), tumor necrosis factor superfamily member 5 (CD154, CD40 ligand)	<i>TNFSF5</i>
Autosomal recessive:	
Activation-induced cytidine deaminase (HIM2)	<i>AICDA</i>
Tumor necrosis factor receptor superfamily member 5 (CD40) (HIM3)	<i>TNFRSF5</i>
Uracil nucleoside glycosylase (HIM5)	<i>UNG</i>
Common variable immunodeficiency-like disorders	
Inducible T cell co-stimulator	<i>ICOS</i>
CD19	<i>CD19</i>
CD20	<i>CD20</i>
CD21	<i>CD21</i>
CD81	<i>CD81</i>
NF- $\kappa$ B2	<i>NFKB2</i>
Transmembrane activator and calcium mobilizing ligand interactor (TACI, also tumor necrosis factor receptor superfamily 13B)	<i>TNFRSF13B</i>
B cell activating factor (BAFF) receptor	<i>TNFRSF13C</i>
TNF-related weak inducer of apoptosis (TWEAK)	<i>TNFSF12</i>
Lipopolysaccharide responsive beige-like anchor protein	<i>LRBA</i>
Other	
Protein kinase C- $\delta$	<i>PRKCD</i>
PI3 kinase catalytic subunit $\delta$	<i>PIK3CD</i>
<b>UNKNOWN GENETIC BASIS</b>	
Common variable immunodeficiency	
IgA deficiency	
IgG subclass deficiency	
Specific antibody deficiency with normal immunoglobulins	
Transient hypogammaglobulinemia of infancy	
Hypogammaglobulinemia, unspecified	

arthritis.<sup>9</sup> Opportunistic infections such as *Pneumocystis jiroveci* pneumonia are rare.<sup>10</sup>

About half of XLA patients have a family history of affected male relatives on the maternal side.<sup>11</sup> Autosomal forms of agammaglobulinemia must be distinguished in males without such a history. It is desirable to confirm the diagnosis at the molecular level whenever possible. *BTK* is expressed in platelets and monocytes and may be detected by flow cytometry.<sup>12</sup> These tests are useful for screening males and detecting carrier females who have two populations (*BTK*<sup>+</sup> and *BTK*<sup>-</sup>) of monocytes or platelets as a result of random X chromosome inactivation. Female carriers of XLA show nonrandom X chromosome inactivation in their B cells, and this can also be used for carrier detection.

Some patients with *BTK* mutations have an 'atypical' phenotype with low numbers of B cells and low-level antibody production.<sup>12</sup> In general, mutations that permit low-level function

of *BTK* are more often associated with higher B cell numbers, immunoglobulin levels and antibody formation. Some of these atypical XLA cases may be misdiagnosed as having common variable immunodeficiency (see below). However, even siblings with identical mutations may show divergent clinical features.

### AUTOSOMAL AGAMMAGLOBULINEMIA

A few patients have agammaglobulinemia (AGAM) with autosomal (mostly recessive) patterns of inheritance. Mutations of the immunoglobulin (Ig) $\mu$  heavy chain locus (*IGHM*),<sup>13,14</sup> and defects of  $\lambda$ 5 (surrogate light chain),<sup>14</sup> Ig $\alpha$  (CD79a) and Ig $\beta$  (CD79b), all prevent formation of the pre-B cell Ig receptor. Mutations in *BLNK* (encoding B cell linker protein)<sup>14</sup> and in *PIK3R1* (encoding regulatory subunit 1 of phosphoinositol-3' kinase) disrupt B cell signaling and lead to agammaglobulinemia.<sup>15</sup> All of these disorders have recessive inheritance. The only defined autosomal dominant monogenic agammaglobulinemia is due to defects of transcription factor 3 (*TCF3*).<sup>16</sup> Finally, a single female patient has been described with a translocation interrupting the gene encoding leucine rich repeat containing 8 (*LRRC8*).<sup>17</sup> All of these autosomal defects arrest B cell development at early stages within the bone marrow.

### COMMON VARIABLE IMMUNODEFICIENCY

The diagnosis of common variable immunodeficiency (CVID) encompasses an unknown number of genetically and etiologically distinct conditions having in common a (relatively) late-onset humoral immunodeficiency, most often in the first or third decade of life.<sup>18</sup> Due to rapid development of the immune system in childhood, and frequent resolution of hypogammaglobulinemia in young children,<sup>19</sup> it is not considered appropriate to confer a diagnosis of CVID under 4 years of age.<sup>20</sup>

CVID is defined by laboratory and clinical criteria; there is no universal consensus on the necessary elements establishing the diagnosis.<sup>20</sup> All patients have low IgG and impaired antibody response. Some authorities require that IgA also be low to establish the diagnosis, while others accept that IgA and/or IgM may be normal or low. Not all patients with CVID have infections, nor are symptoms a component of the definition (i.e. one may have 'asymptomatic' CVID).

Many CVID patients have recurrent sinopulmonary bacterial infections. Additional manifestations include asthma, chronic rhinosinusitis, inflammatory bowel disease, and recurrent or chronic arthropathy. The apparent 'atopic' symptoms mimicking asthma and chronic rhinosinusitis found in about 10% of patients do not involve allergen-specific IgE. Autoimmune cytopenias also occur with increased frequency. In addition, noncaseating granulomatous disease resembling sarcoidosis may involve the skin or viscera, even in children.

Lymphoproliferation may cause splenomegaly, adenopathy and intestinal lymphonodular hyperplasia, and CVID patients also have a higher incidence of lymphoid and gastrointestinal malignancy. The relative risk of lymphoma is estimated to be 10–20-fold greater than in the general population.<sup>21</sup> Most of these are B cell non-Hodgkin's lymphomas not associated with Epstein-Barr virus (EBV).<sup>22</sup>

Numbers of peripheral B and T cells are variable in CVID; particular abnormalities may correlate with phenotype. After activation, B cells may 'switch' isotype production from IgM and IgD to IgG, IgA or IgE (see section on [hyper-IgM](#)

syndromes). Memory B cells express the surface marker CD27. Levels of 'switched' (IgM<sup>-</sup>IgD<sup>+</sup>) memory (CD27<sup>+</sup>) cells correlate with disease phenotype. Levels below 1–2% of B cells are associated with a higher rate of severe infection, autoimmune disease, lymphoproliferation and lymphoma.<sup>23,24</sup> The T cell phenotype is also variable. Low levels of naïve (CD45RA<sup>+</sup>) CD4 T cells correlate with these complications.<sup>25</sup>

Causative genetic lesions have been identified in about 1% of patients with CVID or CVID-like syndromes. These include defects of inducible T cell co-stimulator (ICOS)<sup>26</sup> and several surface glycoproteins important for B cell activation including CD19,<sup>27</sup> CD20,<sup>28</sup> CD21<sup>29</sup> and CD81.<sup>30</sup> Other monogenic forms of CVID-like hypogammaglobulinemia include defects of protein kinase C  $\delta$ ,<sup>31</sup> NF- $\kappa$ B2<sup>32</sup> and the lipopolysaccharide responsive beige like anchor protein (LRBA).<sup>33</sup>

Additional genetic associations occur in subgroups of CVID patients. Some functionally important polymorphisms of the transmembrane activator and calcium mobilizing ligand interactor (TACI) are found in a higher proportion of CVID patients (5–10%) in comparison to the general population (1%).<sup>34</sup> This molecule, also called tumor necrosis factor receptor superfamily member 5 (TNFRSF5), is expressed on activated B cells. Patients with CVID may be homozygous or heterozygous for polymorphisms in TACI. However, these alterations in TACI are not disease-causing; some healthy individuals harbor the same genetic changes.<sup>35</sup>

X-linked lymphoproliferative disease (XLP) arises from defects in the SLAM (signaling lymphocytic activation molecule)-associated protein (SAP) signal transducing molecule. Some of these patients have dysgammaglobulinemias of various types, and a few had been classified as having CVID before the discovery of the genetic basis of XLP.<sup>36</sup> It is important to rule out XLP in males with a CVID phenotype because prognosis and therapy are distinct for these disorders. Rarely, patients with XLA may be misdiagnosed as having CVID.<sup>37</sup>

The occurrence of thymoma and hypogammaglobulinemia with low B cell numbers has been designated Good's syndrome.<sup>38</sup> It is unknown if these patients have genetic or immunologic distinctions from CVID. Disseminated and opportunistic infections (such as *P. jiroveci* pneumonia) occur more frequently in Good's syndrome and prognosis is worse than that for most CVID patients. Approximately 10% of CVID patients have severe CD4 lymphocytopenia (<200 cells/ $\mu$ L) and/or an opportunistic infection. Several complications (intestinal disease, splenomegaly, lymphomas and granulomas) are more frequent in this subset.<sup>39</sup> This has been called 'late onset combined immunodeficiency' (LOCID) and is similar to Good's syndrome, with the exception of thymoma.

## IgA DEFICIENCY

Human IgA is divided into two subclasses – IgA1 and IgA2 – encoded by separate genes. IgA1 constitutes 80% to 90% of serum IgA; both contribute equally to secretory IgA. Both subclasses are affected in IgA deficiency (IGAD). Very low levels of IgA (<7 mg/dL) are found in about 1:500–700 Caucasians.<sup>40</sup> This is called selective IgA deficiency (IGAD). Clinical associations with levels of IgA above this threshold but below the normal range ('low' IgA) are not well established. As with CVID, due to rapid immune system development in children and wider normal ranges of immunoglobulin levels in early childhood, it is not appropriate to confer a diagnosis of IGAD below

the age of 4 years.<sup>2</sup> Many individuals with IGAD are asymptomatic. However, more than 80% have clinical manifestations similar to CVID or IgG subclass deficiency including viral and bacterial upper and lower respiratory tract infections, atopic disease and autoimmunity.<sup>41</sup>

Autoimmune syndromes in IGAD include rheumatoid arthritis, systemic lupus erythematosus, Sjögren syndrome, insulin-dependent diabetes mellitus and other endocrinopathies, pernicious anemia, hemolytic anemia, Crohn's disease and autoimmune hepatitis.<sup>41–43</sup> The forms of malignancy associated with CVID do not appear to occur with greater frequency in IGAD in comparison to the general population.<sup>44</sup> Rare cases of IGAD may evolve into CVID or improve over time.<sup>45</sup> About one third of IGAD patients have a concomitant IgG subclass deficiency (see below). This association is more frequently accompanied by deficits in specific antibody production and significant infectious complications in comparison to the absence of IgA alone.<sup>46,47</sup> The same T and B cell abnormalities found in CVID patients are observed in those with IGAD, albeit in a smaller proportion in comparison to controls.<sup>48</sup>

No disease-causing single gene defects underlying IGAD have been defined. The polymorphisms of *MSH5* described above are associated with the A1-B8-DR3 extended HLA haplotype and have also been found in individuals with IGAD. IGAD has been reported in patients after chemotherapy<sup>49</sup> or treatment with anticonvulsants such as phenytoin.<sup>50</sup> In the latter case, the effect was reversible with drug discontinuation.

## IgG SUBCLASS DEFICIENCY

Human IgG is divided into four subclasses designated IgG1, IgG2, IgG3 and IgG4, each encoded by different Ig constant region genes. Each represents approximately 67%, 23%, 7% and 3% of the total, respectively.<sup>51</sup> IgG subclasses are produced in different relative amounts depending on the antigenic stimulus. For example, IgG1 predominates in responses to soluble protein antigens, and responses to pneumococcal capsular polysaccharides consist almost entirely of the IgG2 subclass.

A consensus definition of IgG subclass deficiency does not exist. In contrast to CVID or IGAD, a clinical significance of abnormal IgG subclass levels has not been established outside the context of recurrent infections. Thus, this should be considered an element of the definition. In a patient with recurrent infections, a disproportionately low level (<2 SD below the mean or <5th percentile) of one or more IgG subclasses with a normal total serum IgG may constitute an IgG subclass deficiency (IGGSD). Levels should be abnormal on at least two measurements more than 1 month apart. Many authorities insist that impaired vaccine response (usually to polysaccharide antigens) also be included in the definition. In one recent case-control study of patients with recurrent respiratory infections, pneumococcal polysaccharide responses did not correlate with IgG2 or IgG3 serum levels.<sup>52</sup> This emphasizes the importance of direct assessment of vaccine response in patient evaluation, rather than relying on subclass measurement alone.

Diagnostic controversy arises due to interlaboratory variation in immunoglobulin subclass determinations and differences in normal ranges depending on age and ethnicity. As with CVID and IGAD, caution should be exercised when conferring this diagnosis in patients less than 4 years of age. Furthermore, since low subclass levels are defined based on population statistics, most individuals with isolated low IgG subclass levels are

asymptomatic, rendering its significance questionable in patients with recurrent infections. However, some studies show a higher prevalence of subclass deficiency in groups of patients with chronic or recurrent sinopulmonary bacterial infections.<sup>53,54</sup> Not all of these patients have impaired specific antibody responses. Thus, the connection between IgG subclass deficiency and susceptibility to infection or other disease may be difficult to demonstrate.

Individuals with IGGSD most often present with recurrent sinopulmonary infections of varying severity caused by common respiratory bacterial pathogens.<sup>55</sup> Additional manifestations include frequent viral infections, recurrent diarrhea (infectious or allergic) and atopic diseases such as asthma and allergic rhinitis, and autoimmunity.<sup>56</sup> Lymphoproliferative disease has been reported in association with IGGSD, although its significance is unknown.<sup>22</sup>

IgG subclass deficiencies occur in various patterns. Low IgG2 is most common in children (male > female). It may occur in isolation but is also frequently associated with IgG4 and/or IgA deficiency.<sup>57</sup> Selective IgG3 deficiency is found more commonly in women and may be associated with low levels of IgG1.<sup>58</sup> Recurrent infections have also been reported in association with only low IgG4.<sup>59</sup> Young children with IGGSD often improve with time: 50% to 70% (depending on the pattern of Ig abnormalities) achieve normal serum levels by age 6.<sup>47</sup>

Abnormalities of lymphocyte populations have not been established in IGGSD. Some have found low levels of switched memory B cells (as in CVID) in some individuals with IGGSD.<sup>60</sup> IGGSD is not commonly the result of genetic lesions in the human Ig heavy-chain locus. In fact, most individuals with deletions in this locus with restricted IgG subclass expression are asymptomatic.<sup>61</sup> Mutations preventing expression of cell surface IgG2 have been found in a few reported cases of IgG2 deficiency.<sup>62</sup>

### SPECIFIC ANTIBODY DEFICIENCY WITH NORMAL IMMUNOGLOBULINS

Some patients with recurrent infections and poor antibody responses (mainly to polysaccharide antigens) have normal levels of antibody classes and subclasses. This is called 'specific antibody deficiency with normal immunoglobulins' (SADNI) or 'functional antibody deficiency'.<sup>63</sup> In one tertiary care center, SADNI was the most frequent diagnosis among patients evaluated for immunodeficiency (23%).<sup>64</sup> In another recent study, poor response to pneumococcal polysaccharides was found in 58% of 24 children evaluated for chronic productive cough.<sup>63</sup> In a larger cohort of 129 adult patients with chronic rhinosinusitis, more than 11% had a diagnosis of SADNI.<sup>65</sup> In one retrospective study of 72 patients, approximately 8% exhibited autoimmunity and 5% had chronic enteropathy.<sup>66</sup> Abnormalities of lymphocyte populations are not well described, though low levels of switched memory B cells are found in some patients.<sup>67</sup>

### TRANSIENT HYPOGAMMAGLOBULINEMIA OF INFANCY

In humans, IgG is transported from the mother to the fetus during gestation. Maternal antibody has a half-life in the infant between 20 and 30 days. A nadir of IgG occurs at 3 to 9 months of age as maternal IgG is cleared and newborn production

begins. Transient hypogammaglobulinemia of infancy (THI) is an IgG deficiency that begins in infancy and resolves spontaneously by 5 years of age.<sup>68</sup> Thus, the diagnosis can be confirmed only after IgG levels normalize. By definition, IgG is lower than normal for age. Many of these children are asymptomatic. Beginning at about 6 months of age, many (>90%) of these IgG-deficient children manifest the types of recurrent infections associated with hypogammaglobulinemia.<sup>69</sup> Severe infections are not often seen, but vaccine strain polio meningoencephalitis has been reported in one case of THI.<sup>70</sup> Fifty to eighty per cent of patients are atopic and autoimmunity may be seen in a small fraction (4%).<sup>69,71</sup>

Patients with higher initial IgG levels and males normalize more rapidly.<sup>68,71</sup> High total B cells, low memory B cells and reduced CD19 on B cells have been described in patients with THI.<sup>69,71-73</sup>

Many studies indicate mainly normal vaccine responses in THI, but one study documented poor responses to Hib vaccine in a majority and to tetanus in one third of patients.<sup>71</sup> Those with low levels of IgA and IgM and poor vaccine responses had longer time to resolution and a higher rate of persistent hypogammaglobulinemia.<sup>19,68,69,71</sup>

### HYPER-IgM SYNDROMES

The eponym 'hyper-IgM syndrome' is applied to immunodeficiency with defective Ig class switching. In primary antibody responses, IgM is produced initially; IgG and other isotypes are produced later. This is called *class switching* and requires genetic rearrangement to juxtapose the Ig variable region gene with a new heavy-chain gene. If this process fails, IgM predominates in antibody responses without other isotypes being produced. The X-linked hyper-IgM syndrome (abbreviated XHIM or HIM1) is an immunodeficiency resulting from defects in TNFSF5 (tumor necrosis factor superfamily member 5).<sup>74</sup> This is also called CD154 or CD40 ligand (CD40L). This is truly a combined immunodeficiency because the interactions of T cells with antigen-presenting cells and mononuclear cells are impaired. However, HIM1 is often classified with antibody deficiencies because hypogammaglobulinemia is such a prominent feature.

Usually within the first 2 years of life, patients with HIM1 develop recurrent bacterial infections generally seen in hypogammaglobulinemia.<sup>74</sup> They also have opportunistic infections from fungal pathogens such as *Pneumocystis*, *Histoplasma* and others.<sup>75</sup> Additional infections include erythrovirus and sclerosing cholangitis due to *Cryptosporidium*. Noninfectious complications include neutropenia and hepatic and hematologic malignancies.

In HIM1, IgG is low and IgM is normal or high; more than half of patients lack IgA.<sup>74</sup> Specific antibody formation is often impaired. Patients make IgM antibody in response to immunization or infection but little IgG. Antibody levels wane rapidly, and there are no memory responses. Secondary lymphoid tissues are poorly developed and do not contain germinal centers. The diagnosis is established by demonstrating a failure of T cells to express CD40L after stimulation. The diagnosis should be confirmed with molecular genetic study.

Forms of hyper-IgM syndrome with autosomal (mostly recessive) inheritance have also been described. 'Hyper-IgM syndrome type 3' (HIM3) results from mutations in the gene encoding tumor necrosis factor receptor superfamily member



5 (TNFRSF5), also known as CD40.<sup>76</sup> Because this is the ligand for TNFSF5 (HIM1), the same cellular interactions are affected.

Two additional forms of autosomal hyper-IgM syndrome are due to mutations of the genes encoding activation-induced cytidine deaminase (AID) and uracil nucleoside glycosylase (UNG).<sup>76,77</sup> These are called HIM2 and HIM5, respectively. Bacterial sinopulmonary infections occur in these patients along with diarrhea, failure to thrive and lymphadenopathy. These defects affect only class-switch machinery in B cells; T cell function is completely intact and opportunistic infections are not observed.

Another form of hyper-IgM syndrome (unknown defect) has been designated 'hyper-IgM syndrome type 4'.<sup>78,79</sup> This is a milder antibody deficiency with residual IgG production and an intrinsic B cell class-switch defect with normal T cell function. Immune function may normalize over time in some patients.<sup>78</sup>

A few patients have been described with a hyper-IgM phenotype and defects of PI3 kinase catalytic subunit  $\delta$  (PI3KCD).<sup>80</sup>

## Differential Diagnosis

Clinical entities that mimic antibody deficiency are listed in [Box 8-1](#). The most frequent presentation of antibody deficiency includes recurrent, frequent and severe respiratory tract infections with encapsulated bacteria.<sup>3,4</sup> Additional bacterial infections may occur in other sites, along with frequent viral infections and noninfectious complications. Of course, antibody deficiency may accompany cellular immunodeficiency (i.e. combined immunodeficiency). Normal cellular immune function should be confirmed in all cases of abnormal humoral immunity ([Figure 8-1](#)).

Secondary or acquired antibody deficiency is more prevalent than primary humoral deficiency in adults; the opposite is true for children. Secondary antibody deficiency can occur with abnormal loss of lymph or plasma (lymphangiectasia, nephrosis, protein-losing enteropathy).<sup>81</sup> Hypogammaglobulinemia also occurs with malignancy (e.g. chronic lymphocytic

leukemia) or following chemotherapy or immunomodulation (e.g. rituximab) for cancer or autoimmune disease, or immunosuppressive therapy following solid organ transplantation. With abnormal protein loss, vaccine antibody levels are preserved, unless hypogammaglobulinemia is profound. The opposite is true for other causes of secondary hypogammaglobulinemia.

Complement deficiency presents with infections characteristic of antibody deficiency.<sup>82</sup> Patients with phagocyte defects may also present with respiratory bacterial infections.<sup>83</sup> However, they frequently present with distinct infectious complications such as deep-seated abscesses or cellulitis, which are not as often seen in antibody deficiencies (although they do occur occasionally).

Some nonimmune disorders such as cystic fibrosis and ciliary dysfunction mimic antibody deficiencies.<sup>84,85</sup> Nasopharyngeal anatomic defects, hyperplasia of lymphoid tissue or allergic rhinosinusitis may cause Eustachian tube or ostiomeatal obstruction and lead to recurrent or chronic otitis media and/or sinusitis. Depending on clinical features, some or all of these disorders should be investigated in patients with normal humoral immunity with infections characteristic of antibody deficiency.

## Evaluation

[Figure 8-1](#) shows an algorithm for evaluation of patients with suspected humoral immunodeficiency. Some combined immunodeficiencies have clinical features that should prompt investigation of cellular immune function.<sup>2</sup> This algorithm assumes that there are no such features because evaluation of cellular immunity would be undertaken immediately in such cases. The following annotations correspond to the numbered elements in [Figure 8-1](#).

1. The descriptions of the diseases mentioned point out the elements of a history that should arouse suspicion of antibody deficiency, the main element being recurrent respiratory tract bacterial and viral infections. Physical examination is nonspecific, showing only the presence or sequelae of infections. Visible or palpable lymphoid tissue may be scarce or absent in some cases, especially in areas rich in B cells (e.g. tonsils). This is most often seen in agammaglobulinemia. Specific diagnosis rests on the laboratory evaluation.
2. The laboratory examination of humoral immunity consists of measuring the levels of various Ig isotypes (IgG, IgA, IgM and IgG subclasses) in serum, as well as a measure of specific antibody production with both protein and polysaccharide antigens. Significant disease may result from selective inability to respond to polysaccharide antigens ([Table 8-2](#)). Antibodies to protein vaccine antigens such as tetanus and diphtheria toxoids are often determined. Antibodies against the capsular polysaccharide (polyribose phosphate [PRP]) of *H. influenzae* type B (Hib) may also be measured. Note that Hib vaccines couple the PRP to a protein carrier, and PRP titers, although specific for a polysaccharide, are indicative of immune response to a protein. Similar considerations apply to measurement of antibodies against conjugated pneumococcal capsular polysaccharides (as in Prevnar vaccines). Antibody levels measured after immunization with unconjugated pneumococcal

### BOX 8-1 DIFFERENTIAL DIAGNOSIS OF RECURRENT RESPIRATORY TRACT BACTERIAL INFECTIONS

Primary humoral immunodeficiency  
 Secondary or acquired humoral immunodeficiency  
 Primary combined immunodeficiency  
   Severe combined immunodeficiency  
   Wiskott-Aldrich syndrome  
   DiGeorge syndrome  
   Ataxia-telangiectasia  
   Many others  
 Secondary or acquired combined immunodeficiency  
 Complement deficiency  
 Phagocytic cell defect  
   Chronic granulomatous disease  
   Leukocyte adhesion defect  
   Chédiak-Higashi syndrome  
   Neutropenia  
 Allergic rhinosinusitis  
 Anatomic obstruction of Eustachian tube or sinus ostia (tumor, foreign body, lymphoid hyperplasia)  
 Cystic fibrosis  
 Ciliary dysfunction



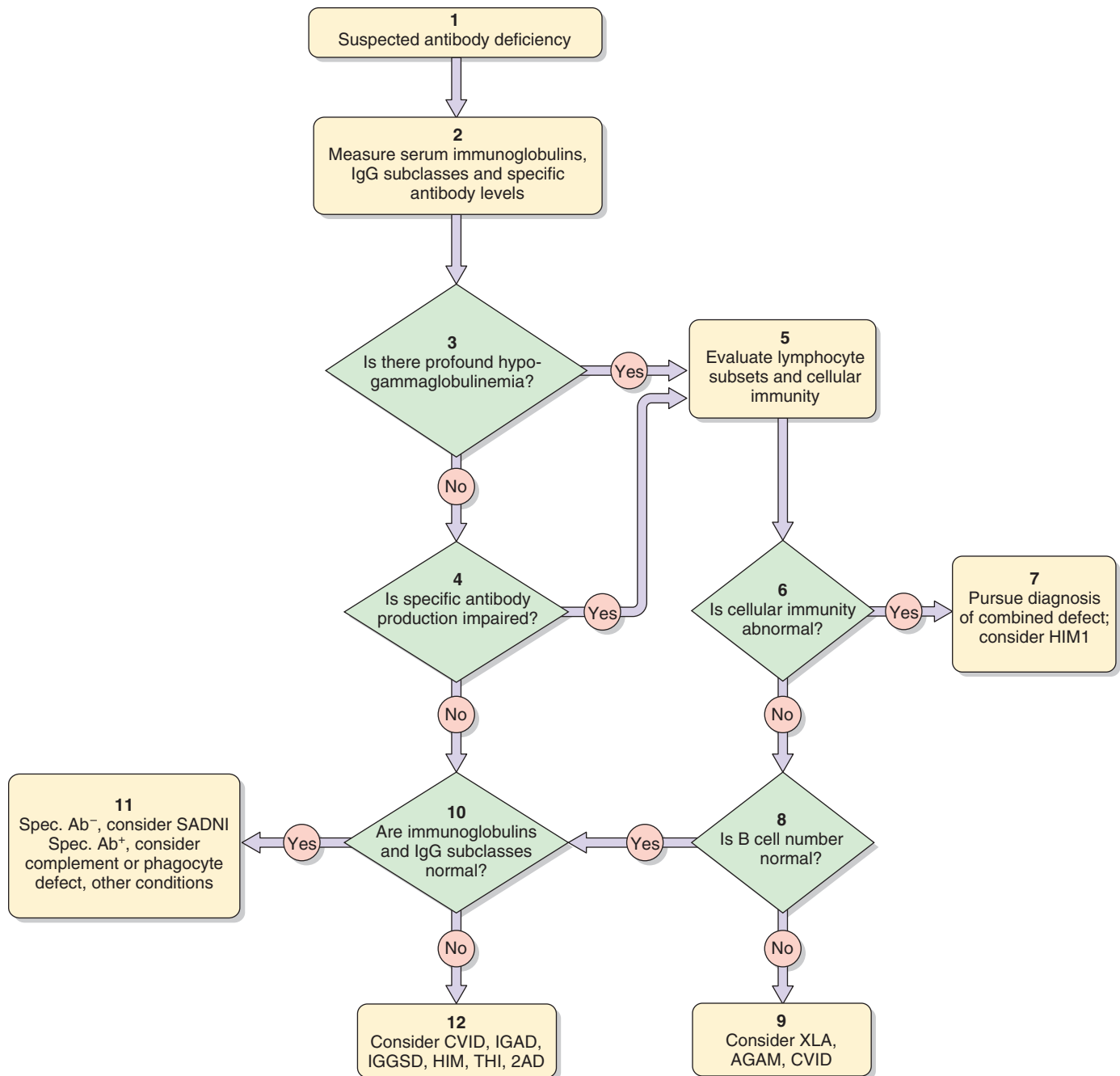

**Figure 8-1** Algorithm for evaluation of the patient with suspected antibody deficiency (see text for annotations and abbreviations).

vaccines are indicative of polysaccharide responses. If initial measurements of antibodies are low, response to booster immunization should be assessed. Post vaccination levels may be determined after 3 to 6 weeks. Polysaccharide antibody responses are reliable in normal children beyond the age of 1 year.<sup>86</sup> Serum isohemagglutinins are naturally occurring antibodies against ABO blood group antigens. They are produced in response to polysaccharide antigens of gut flora, and measurement is sometimes a useful indicator of polysaccharide immunity.<sup>87</sup>

Following immunization with a conjugate pneumococcal vaccine (e.g. Prevnar 13), 0.35  $\mu\text{g}/\text{mL}$  is considered protective for invasive disease with respect to

a single serotype.<sup>88</sup> Seroconversion rates in a healthy population depend on serotype and many healthy children do not respond to all types. Criteria of normal response with respect to the proportion of serotypes have not been established. Following immunization with a polysaccharide pneumococcal vaccine (e.g. Pneumovax), 1.3  $\mu\text{g}/\text{mL}$  is considered protective for invasive disease with respect to a single serotype.<sup>89</sup> The most recent guidelines for assessing response to pneumococcal polysaccharide vaccine<sup>90</sup> indicate:

- Mildly deficient response is concentration  $>1.3 \mu\text{g}/\text{mL}$  for  $>50\%$  of serotypes with a 2-fold rise in level for  $<50\%$  of types under age 6 (70% over age 6).

TABLE  
8-2

Reference Ranges for Serum Immunoglobulins and Specific Antibody Levels

Age	IgG (mg/dL)	IgA (mg/dL)	IgM (mg/dL)
0–1 mo	700–1300	0–11	5–30
1–4 mo	280–750	6–50	15–70
4–7 mo	200–1200	8–90	10–90
7–13 mo	300–1500	16–100	25–115
13 mo–3 yr	400–1300	20–230	30–120
3–6 yr	600–1500	50–150	22–100
6 yr–adult	639–1344	70–312	56–352

Age	IgG1 (mg/dL)	IgG2 (mg/dL)	IgG3 (g/dL)	IgG4 (mg/dL)
Cord	435–1084	143–453	27–146	1–47
0–3 mo	218–496	40–167	4–23	1–120
3–6 mo	143–394	23–147	4–100	1–120
6–9 mo	190–388	37–60	12–62	1–120
9 mo–2 yr	286–680	30–327	13–82	1–120
2–4 yr	381–884	70–443	17–90	1–120
4–6 yr	292–816	83–513	8–111	2–112
6–8 yr	422–802	113–480	15–133	1–138
8–10 yr	456–938	163–513	26–113	1–95
10–12 yr	456–952	147–493	12–179	1–153
12–14 yr	347–993	140–440	23–117	1–143
Adult	422–1292	117–747	41–129	10–67

	Tetanus toxoid (IU/mL)	PRP (Hib) (ng/mL)	Pneumococcus
Protective level	0.15	1000	See notes for <a href="#">Figure 8-1</a>

Age	ISOHEMAGGLUTININ TITER	
	Anti-A	Anti-B
0–6 mo	Unpredictable	Unpredictable
6 mo–2 yr	≥1:4–8	≥1:4–8
2–10 yr	1:4–256	1:16–256
10 yr–adult	≥1:4–8	≥1:4–8

\*These are normal ranges from the laboratories of Children's Hospital, Boston, MA (except isohemagglutinins, see Fong SW, Qaundah BY, Taylor WF: *Transfusion* 1974;14:551.) Normal ranges are method dependent and should be validated for each laboratory. These reference ranges are intended for educational purposes only.

- Moderately deficient response is concentration >1.3 µg/mL for <50% of types under age 6 (70% over age 6).
  - Severely deficient response is concentration >1.3 µg/mL for fewer than 3 serotypes at any age.
  - Poor memory response is an initial 'normal' response which falls below criteria after 6 months.
3. Hypogammaglobulinemia with IgG <100 mg/dL in an infant or <200–300 mg/dL in an older child or adult should prompt additional evaluation of lymphocyte populations and cellular immune function to investigate combined immunodeficiency and B cell number.
  4. Specific antibody responses may be impaired as a result of the failure of T cell help for antibody production, even if serum Ig levels are normal or near normal. This situation should also prompt an evaluation of cellular immunity.
  5. Cellular immunity is evaluated because of either severe hypogammaglobulinemia or impaired specific antibody production.
  6. and 7. If cellular immunity is abnormal, then the eventual diagnosis will be a form of combined immunodeficiency. Recall that HIM1 and HIM3 are combined immunodeficiencies.
  8. Cellular immunity is normal; it is important to determine if there is impaired B cell development.
  9. B cells are absent or severely reduced in XLA or autosomal agammaglobulinemia. A history of affected male relatives on the mother's side establishes the diagnosis of XLA.<sup>11</sup> Demonstration of maternal carrier status is also presumptive evidence. This can be shown by non-random X chromosome inactivation in B cells, or the presence of two populations (BTK<sup>+</sup> and BTK<sup>-</sup>) in monocytes or platelets by flow cytometry.<sup>12,91,92</sup> The diagnosis should be confirmed by molecular analysis. B cells may be low in some cases of CVID.<sup>20</sup>
  10. At this point, either there is not severe hypogammaglobulinemia and antibody formation is not impaired, or antibody is reduced, a cellular immunologic evaluation is normal, and the B cell number is normal. Most

of the remaining diagnoses are clinically defined, in part, by the serum Ig profile.

11. If antibody formation is impaired (Spec.Ab<sup>-</sup>) and serum immunoglobulins are normal, then the diagnosis is SADNI. Otherwise, all measurements are normal (Spec.Ab<sup>+</sup>), and alternative explanations for recurrent infections should be sought. See the discussion on differential diagnosis.
12. There is an immunoglobulin abnormality, with or without demonstrable impairment of specific antibody production. Possible diagnoses include CVID, a form of HIM, IGAD, IGGSD, THI and secondary antibody deficiency.

## Treatment

Therapeutic considerations for antibody deficiency are summarized in Box 8-2. There are two principal modalities to treat patients with antibody deficiencies: antimicrobial therapy (and prophylaxis)<sup>93</sup> and IgG replacement.<sup>94,95</sup> Human polyclonal IgG for therapeutic use has been available for decades and is administered every 2 to 4 weeks via an intravenous infusion, or every 1 to 14 days via subcutaneous infusion. The principal mechanism of benefit of IgG replacement is via passive immunity, i.e. providing protective antibody that patients are incapable of producing themselves. IgG therapy is the subject of Chapter 15.

Antibiotics are used to treat infectious complications before or during IgG replacement. The choice of antibiotic depends on the site of infection, severity, past history of infections and antibiotic use, hypersensitivity and microbiologic sensitivity data, where available. Doses do not need to be adjusted for immunodeficiency, however resolution may be slower in comparison to immunocompetent patients, and treatment may need to be prolonged. In general, one should consider doubling the usual duration of therapy for respiratory tract infections, especially sinusitis, as relapse is likely with shorter courses of antibiotics.

### BOX 8-2 THERAPEUTIC PRINCIPLES FOR ANTIBODY DEFICIENCY

#### AVOID INFECTION

Isolate from obviously contagious individuals  
Avoid large institutional settings for child or elder care  
Practice appropriate public and personal hygiene

#### THERAPY FOR EXISTING INFECTIONS

Antibiotics, standard dose regimens are appropriate, consider extended (double length) course

#### PREVENTION OF INFECTIONS

Immunoglobulin replacement (see Chapter 15)  
Antibiotic prophylaxis

Antibiotic	Children	Adults
Amoxicillin (consider with clavulanate, if necessary)	10–20 mg/kg daily or bid	500 mg daily or bid
Trimethoprim (TMP)/sulfamethoxazole (dosing for TMP)	5 mg/kg daily	160 mg daily
Azithromycin	10 mg/kg weekly or 5 mg/kg every other day	500 mg weekly or 250 mg every other day
Clarithromycin	7.5 mg/kg daily or bid	500 mg daily or bid

Agammaglobulinemia, CVID and HIM are indications for replacement therapy with IgG.<sup>2</sup> The value of IgG replacement for therapy of IGAD, IGGSD, SADNI and THI is not as clear. With some exceptions (mainly in the case of IgG subclass deficiency) IgG replacement is not considered appropriate in IGAD as there is little benefit. These patients and those with IGGSD, SADNI and THI are best managed initially with therapeutic and prophylactic antibiotics<sup>93</sup> and evaluation to rule out other predisposing factors. In the case of patients with IGGSD, SADNI or THI treated with antibiotic prophylaxis, if infections continue to occur with unacceptable frequency or severity, if antibiotics are not tolerated, or especially if antibody responses to immunization are poor, IgG replacement is indicated.

Even with IgG replacement at appropriate doses, sinopulmonary infections may continue at an unacceptable rate, especially in those with more severe disease such as agammaglobulinemia, or CVID or HIM, or with lung damage such as bronchiectasis.<sup>93,95</sup> In these circumstances, antibiotic prophylaxis may be used in addition to IgG. In some patients, this may be required as a permanent adjunct to IgG replacement. For others, it may be possible to administer prophylaxis for several months at a time (e.g. during the winter), or for a few years, after which a patient may tolerate discontinuation. It is always important to consider other potential predisposing factors to chronic rhinosinusitis or bronchitis and to consider additional therapies such as topical nasal or inhaled corticosteroids.<sup>2,20</sup>

Autoimmune, inflammatory or malignant complications of antibody deficiency are generally treated as they would be in other (non-immunodeficiency) contexts. For these types of complications no standardized regimen has been developed specifically for antibody deficient patients. Granulomatous disease in CVID often responds well to immunosuppressive therapy such as steroids, cyclosporine A, thioguanines and rituximab.<sup>96,97</sup> Individuals with preexisting immunodeficiency are at greater risk for infectious or malignant complications of immunomodulatory therapies and they should be monitored very carefully in this regard.

Stem cell therapy is generally not considered for patients with antibody deficiency.<sup>2</sup> One exception may be CVID. Some patients with severe complications of CVID (refractory autoimmune disease or marrow aplasia) have received stem cell therapy.<sup>98</sup> Results have been mixed, but some successful outcomes have been achieved. Stem cell replacement is not yet a standard therapy for CVID; it should be considered on a case-by-case basis.

Immunoglobulin replacement and anti-infective therapy and chemoprophylaxis are the mainstays of therapy for the majority of patients with all forms of HIM.<sup>74,76,77</sup> Recall that HIM due to defects of CD40L or CD40 are combined immunodeficiencies and require prophylaxis against *Pneumocystis jiroveci* pneumonia. Neutropenia in these patients sometimes responds to granulocyte colony-stimulating factor (G-CSF, or filgrastim). Due to the importance of the T cell defect in these patients, stem cell therapy should be considered for any who have suitable donors.<sup>74</sup> Stem cell therapy is not indicated for HIM due to defects of AID and UNG.

## Conclusions

There are no prospective studies that define the incidence of antibody deficiency. Diagnostic controversy exists with respect to what constitutes clinically significant rates or severity of

infection, and there are no criteria regarding such histories with proven sensitivity or specificity leading toward diagnosis of antibody deficiency. Thus, it is important to maintain an index of suspicion in cases where an infectious predisposition appears to exist.

Antibody deficiency is the most prevalent form of primary immunodeficiency and will be encountered by every practicing allergist/immunologist. Simple tools (measurement of serum immunoglobulins and vaccine responses) serve to classify many patients; some may require more specialized evaluation (e.g. flow cytometry and/or functional testing). Nevertheless, screening tests differentiate those requiring more urgent evaluation from those who may be followed over time and managed conservatively, at least initially.

Many infants and young children with antibody deficiency improve over time and may no longer suffer from recurrent infections after several years. No large long-term prospective studies have been undertaken to determine whether or not these individuals go on to suffer excessive immunologic disorders or malignancies in comparison to the general population. It is unlikely that a primary antibody deficiency diagnosed in

an older child or adult will improve over time. Although it may be reassuring that a large proportion of younger patients appear to improve with time, this will certainly not be the case for all. Even for patients who are destined to 'recover', early diagnosis is critical for preventing significant morbidity and mortality.

The complete reference list can be found on the companion Expert Consult website at <http://www.expertconsult.inkling.com>.

### HELPFUL WEBSITES

The American Academy of Allergy, Asthma and Immunology ([www.aaaai.org](http://www.aaaai.org))

The Clinical Immunology Society ([www.clinimmsoc.org/](http://www.clinimmsoc.org/))

The Immune Deficiency Foundation ([www.primaryimmune.org](http://www.primaryimmune.org))

The Immunodeficiency Resource ([www.uta.fi/imt/bioinfo/idr](http://www.uta.fi/imt/bioinfo/idr))

The Primary Immunodeficiency Resource Center ([www.info4pi.org](http://www.info4pi.org))

### KEY REFERENCES

- Al-Herz W, Bousfiha A, Casanova JL, Chatila T, Conley ME, Cunningham-Rundles C, et al. Primary immunodeficiency diseases: an update on the classification from the international union of immunological societies expert committee for primary immunodeficiency. *Front Immunol* 2014;5:162.
- Bonilla FA, Khan DA, Ballas ZK, Chinen J, Frank MM, Hsu JT, et al. Practice parameter for the diagnosis and management of primary immunodeficiency. *J Allergy Clin Immunol* 2015 (in press).
- Durandy A, Kracker S, Fischer A. Primary antibody deficiencies. *Nat Rev Immunol* 2013;13:519–33.
- Gathmann B, Mahlaoui N, Gerard L, Oksenhendler E, Warnatz K, Schulze I, et al. Clinical picture and treatment of 2212 patients with common variable immunodeficiency. *J Allergy Clin Immunol* 2014.
- Bonilla FA, Barlan I, Chapel H, Costa-Carvalho BT, Cunningham-Rundles C, de la Morena MT, et al. ICON: international consensus document for common variable immunodeficiency (CVID). (Submitted). 2014.
- Rachid R, Bonilla FA. The role of anti-IgA antibodies in causing adverse reactions to gamma globulin infusion in immunodeficient patients: a comprehensive review of the literature. *J Allergy Clin Immunol* 2012;129:628–34.
- Qamar N, Fuleihan RL. The hyper IgM syndromes. *Clin Rev Allergy Immunol* 2014;46:120–30.
- Duraisingham SS, Buckland MS, Grigoriadou S, Longhurst HJ. Secondary antibody deficiency. *Exp Rev Clin Immunol* 2014;10:583–91.
- Orange JS, Ballou M, Stiehm ER, Ballas ZK, Chinen J, De La Morena M, et al. Use and interpretation of diagnostic vaccination in primary immunodeficiency: a working group report of the Basic and Clinical Immunology Interest Section of the American Academy of Allergy, Asthma & Immunology. *J Allergy Clin Immunol* 2012;130(Suppl. 3):S1–24.
- Kuruville M, de la Morena MT. Antibiotic prophylaxis in primary immune deficiency disorders. *J Allergy Clin Immunol Pract* 2013;1:573–82.



## REFERENCES

- Al-Herz W, Bousfiha A, Casanova JL, Chatila T, Conley ME, Cunningham-Rundles C, et al. Primary immunodeficiency diseases: an update on the classification from the international union of immunological societies expert committee for primary immunodeficiency. *Front Immunol* 2014;5:162.
- Bonilla FA, Khan DA, Ballas ZK, Chinen J, Frank MM, Hsu JT, et al. Practice parameter for the diagnosis and management of primary immunodeficiency. *J Allergy Clin Immunol* 2015 (in press).
- Durandy A, Kracker S, Fischer A. Primary antibody deficiencies. *Nat Rev Immunol* 2013;13:519–33.
- Costa-Carvalho BT, Wandalsen GF, Pulici G, Aranda CS, Sole D. Pulmonary complications in patients with antibody deficiency. *Allergol Immunopathol* 2011;39:128–32.
- Hurst JR, Workman S, Garcha DS, Seneviratne SL, Haddock JA, Grimbacher B. Activity, severity and impact of respiratory disease in primary antibody deficiency syndromes. *J Clin Immunol* 2014;34:68–75.
- Rezaei N, Bonilla FA, Sullivan KE, de Vries E, Orange JS. An introduction to primary immunodeficiency diseases. In: Rezaei N, Aghamohammadi A, Notarangelo L, editors. *Primary Immunodeficiency diseases: definition, diagnosis, management*. Berlin: Springer-Verlag; 2008. p. 1–38.
- Khan WN. Colonel Bruton's kinase defined the molecular basis of X-linked agammaglobulinemia, the first primary immunodeficiency. *J Immunol* 2012;188:2933–5.
- Mohamed AJ, Yu L, Backesjo CM, Vargas L, Faryal R, Aints A, et al. Bruton's tyrosine kinase (Btk): function, regulation, and transformation with special emphasis on the PH domain. *Immunol Rev* 2009;228:58–73.
- Bloom KA, Chung D, Cunningham-Rundles C. Osteoarticular infectious complications in patients with primary immunodeficiencies. *Curr Opin Rheumatol* 2008;20:480–5.
- Sirianni MC, Atzori C, De Santis W, Milito C, Esposito A, Marziali M, et al. A case of Pneumocystis jiroveci pneumonia in X-linked agammaglobulinemia treated with immunosuppressive therapy: a lesson for immunologists. *Int Arch Allergy Immunol* 2006;140:82–8.
- Conley ME, Rohrer J, Minegishi Y. X-linked agammaglobulinemia. *Clin Rev Allergy Immunol* 2000;19:183–204.
- Lee PP, Chen TX, Jiang LP, Chan KW, Yang W, Lee BW, et al. Clinical characteristics and genotype-phenotype correlation in 62 patients with X-linked agammaglobulinemia. *J Clin Immunol* 2010;30:121–31.
- Ferrari S, Zuntini R, Lougaris V, Soresina A, Sourkova V, Fiorini M, et al. Molecular analysis of the pre-BCR complex in a large cohort of patients affected by autosomal-recessive agammaglobulinemia. *Genes Immun* 2007;8:325–33.
- Conley ME, Broides A, Hernandez-Trujillo V, Howard V, Kanegane H, Miyawaki T, et al. Genetic analysis of patients with defects in early B-cell development. *Immunol Rev* 2005;203:216–34.
- Conley ME, Dobbs AK, Quintana AM, Bosompem A, Wang YD, Coustan-Smith E, et al. Agammaglobulinemia and absent B lineage cells in a patient lacking the p85alpha subunit of PI3K. *J Exp Med* 2012;209:463–70.
- Boisson B, Wang YD, Bosompem A, Ma CS, Lim A, Kochetkov T, et al. A recurrent dominant negative E47 mutation causes agammaglobulinemia and BCR(-) B cells. *J Clin Invest* 2013;123:4781–5.
- Sawada A, Takihara Y, Kim JY, Matsuda-Hashii Y, Tokimasa S, Fujisaki H, et al. A congenital mutation of the novel gene LRRC8 causes agammaglobulinemia in humans. *J Clin Invest* 2003;112:1707–13.
- Gathmann B, Mahlaoui N, Gerard L, Oksenhendler E, Warnatz K, Schulze I, et al. Clinical picture and treatment of 2212 patients with common variable immunodeficiency. *J Allergy Clin Immunol* 2014.
- Ozen A, Baris S, Karakoc-Aydiner E, Ozdemir C, Bahceciler NN, Barlan IB. Outcome of hypogammaglobulinemia in children: immunoglobulin levels as predictors. *Clin Immunol* 2010;137:374–83.
- Bonilla FA, Barlan I, Chapel H, Costa-Carvalho BT, Cunningham-Rundles C, de la Morena MT, et al. ICON: international consensus document for common variable immunodeficiency (CVID). Submitted, 2014.
- Salavoura K, Kolialexi A, Tsangaris G, Mavrou A. Development of cancer in patients with primary immunodeficiencies. *Anticancer Res* 2008;28:1263–9.
- Gompels MM, Hodges E, Lock RJ, Angus B, White H, Larkin A, et al. Lymphoproliferative disease in antibody deficiency: a multi-centre study. *Clin Exp Immunol* 2003;134:314–20.
- Piatosa B, Pac M, Siewiera K, Pietrucha B, Klau-del-Dreszler M, Heropolitanska-Pliszka E, et al. Common variable immune deficiency in children—clinical characteristics varies depending on defect in peripheral B cell maturation. *J Clin Immunol* 2013;33:731–41.
- Al Kindi M, Mundy J, Sullivan T, Smith W, Kette F, Smith A, et al. Utility of peripheral blood B cell subsets analysis in common variable immunodeficiency. *Clin Exp Immunol* 2012;167:275–81.
- Bateman EA, Ayers L, Sadler R, Lucas M, Roberts C, Woods A, et al. T cell phenotypes in patients with common variable immunodeficiency disorders: associations with clinical phenotypes in comparison with other groups with recurrent infections. *Clin Exp Immunol* 2012;170:202–11.
- Yong PE, Salzer U, Grimbacher B. The role of costimulation in antibody deficiencies: ICOS and common variable immunodeficiency. *Immunol Rev* 2009;229:101–13.
- van Zelm MC, Bartol SJ, Driessen GJ, Mascart F, Reisli I, Franco JL, et al. Human CD19 and CD40L deficiencies impair antibody selection and differentially affect somatic hypermutation. *J Allergy Clin Immunol* 2014.
- Kuijpers TW, Bende RJ, Baars PA, Grummels A, Derks IA, Dolman KM, et al. CD20 deficiency in humans results in impaired T cell-independent antibody responses. *J Clin Invest* 2010;120:214–22.
- Thiel J, Kimmig L, Salzer U, Grudzien M, Lebrecht D, Hagen T, et al. Genetic CD21 deficiency is associated with hypogammaglobulinemia. *J Allergy Clin Immunol* 2012;129:801–10.e6.
- van Zelm MC, Smet J, Adams B, Mascart F, Schandene L, Janssen F, et al. CD81 gene defect in humans disrupts CD19 complex formation and leads to antibody deficiency. *J Clin Invest* 2010;120:1265–74.
- Salzer E, Santos-Valente E, Klaver S, Ban SA, Emminger W, Prengemann NK, et al. B-cell deficiency and severe autoimmunity caused by deficiency of protein kinase C delta. *Blood* 2013;121:3112–16.
- Chen K, Coonrod EM, Kumanovics A, Franks ZF, Durtschi JD, Margraf RL, et al. Germline mutations in NFKB2 implicate the noncanonical NF-kappaB pathway in the pathogenesis of common variable immunodeficiency. *Am J Hum Genet* 2013;93:812–24.
- Alangari A, Alsultan A, Adly N, Massaad MJ, Kiani IS, Aljebreen A, et al. LPS-responsive beige-like anchor (LRBA) gene mutation in a family with inflammatory bowel disease and combined immunodeficiency. *J Allergy Clin Immunol* 2012;130:481–8.e2.
- Romberg N, Chamberlain N, Saadoun D, Gentile M, Kinnunen T, Ng YS, et al. CVID-associated TACI mutations affect autoreactive B cell selection and activation. *J Clin Invest* 2013;123:4283–93.
- Pan-Hammarstrom Q, Salzer U, Du L, Bjorkander J, Cunningham-Rundles C, Nelson DL, et al. Reexamining the role of TACI coding variants in common variable immunodeficiency and selective IgA deficiency. *Nat Genet* 2007;39:429–30.
- Morra M, Howie D, Grande MS, Sayos J, Wang N, Wu C, et al. X-linked lymphoproliferative disease: a progressive immunodeficiency. *Annu Rev Immunol* 2001;19:657–82.
- Weston SA, Prasad ML, Mullighan CG, Chapel H, Benson EM. Assessment of male CVID patients for mutations in the Btk gene: how many have been misdiagnosed? *Clin Exp Immunol* 2001;124:465–9.
- Frieri M. Good's syndrome, CVID, and selective antibody deficiency in patients with chronic rhinosinusitis. *Curr Allergy Asthma Rep* 2014;14:438.
- Malphettes M, Gerard L, Carmagnat M, Mouillot G, Vince N, Boutboul D, et al. Late-onset combined immune deficiency: a subset of common variable immunodeficiency with severe T cell defect. *Clin Infect Dis* 2009;49:1329–38.
- Rachid R, Bonilla FA. The role of anti-IgA antibodies in causing adverse reactions to gamma globulin infusion in immunodeficient patients: a comprehensive review of the literature. *J Allergy Clin Immunol* 2012;129:628–34.
- Jorgensen GH, Gardulf A, Sigurdsson MI, Sigurdardottir ST, Thorsteinsdottir I, Gudmundsson S, et al. Clinical symptoms in adults with selective IgA deficiency: a case-control study. *J Clin Immunol* 2013.
- Singh K, Chang C, Gershwin ME. IgA deficiency and autoimmunity. *Autoimmun Rev* 2014;13:163–77.
- Wang N, Shen N, Vyse TJ, Anand V, Gunnarson I, Sturfelt G, et al. Selective IgA deficiency in autoimmune diseases. *Mol Med* 2011;17:1383–96.
- Mellemkjaer L, Hammarstrom L, Andersen V, Yuen J, Heilmann C, Barington T, et al. Cancer risk among patients with IgA deficiency or common variable immunodeficiency and their relatives: a combined Danish and Swedish study. *Clin Exp Immunol* 2002;130:495–500.

45. Aghamohammadi A, Mohammadi J, Parvaneh N, Rezaei N, Moin M, Espanol T, et al. Progression of selective IgA deficiency to common variable immunodeficiency. *Int Arch Allergy Immunol* 2008;147:87–92.
46. Edwards E, Razvi S, Cunningham-Rundles C. IgA deficiency: clinical correlates and responses to pneumococcal vaccine. *Clin Immunol* 2004;111:93–7.
47. Kutukculer N, Karaca NE, Demircioglu O, Aksu G. Increases in serum immunoglobulins to age-related normal levels in children with IgA and/or IgG subclass deficiency. *Pediatr Allergy Immunol* 2007;18:167–73.
48. Nechvatalova J, Pikulova Z, Stikarovska D, Pesak S, Vlkova M, Litzman J. B-lymphocyte subpopulations in patients with selective IgA deficiency. *J Clin Immunol* 2012;32:441–8.
49. Uram R, Rosoff PM. Isolated IgA deficiency after chemotherapy for acute myelogenous leukemia in an infant. *Pediatr Hematol Oncol* 2003;20:487–92.
50. Braconier JH. Reversible total IgA deficiency associated with phenytoin treatment. *Scand J Infect Dis* 1999;31:515–16.
51. Ferrante A, Beard LJ, Feldman RG. IgG subclass distribution of antibodies to bacterial and viral antigens. *Pediatr Infect Dis J* 1990;9(Suppl. 3):S16–24.
52. Sherkat R, Shoaie P, Parvaneh N, Babak A, Kassaian N. Selective antibody deficiency and its relation to the IgG2 and IgG3 subclass titers in recurrent respiratory infections. *Iran J Immunol* 2013;10:55–60.
53. De Gracia J, Rodrigo MJ, Morell F, Vendrell M, Miravittles M, Cruz MJ, et al. IgG subclass deficiencies associated with bronchiectasis. *Am J Respir Crit Care Med* 1996;153:650–5.
54. Olander-Nielsen AM, Granert C, Forsberg P, Friman V, Victorisz A, Bjorkander J. Immunoglobulin prophylaxis in 350 adults with IgG subclass deficiency and recurrent respiratory tract infections: a long-term follow-up. *Scand J Infect Dis* 2007;39:44–50.
55. Maarschalk-Ellebroek LJ, Hoepelman AI, van Montfrans JM, Ellebroek PM. The spectrum of disease manifestations in patients with common variable immunodeficiency disorders and partial antibody deficiency in a university hospital. *J Clin Immunol* 2012;32:907–21.
56. Ozcan C, Metin A, Erkocoglu M, Kocabas CN. Allergic diseases in children with primary immunodeficiencies. *Turk J Pediatr* 2014;56:41–7.
57. French MA, Denis KA, Dawkins R, Peter JB. Severity of infections in IgA deficiency: correlation with decreased serum antibodies to pneumococcal polysaccharides and decreased serum IgG2 and/or IgG4. *Clin Exp Immunol* 1995;100:47–53.
58. Barlan IB, Geha RS, Schneider LC. Therapy for patients with recurrent infections and low serum IgG3 levels. *J Allergy Clin Immunol* 1993;92:353–5.
59. Etzioni A. IgG4 deficiency and recurrent respiratory infections. *J Pediatr* 1992;121:332.
60. van de Ven AA, van de Corput L, van Tilburg CM, Tesselaar K, van Gent R, Sanders EA, et al. Lymphocyte characteristics in children with common variable immunodeficiency. *Clin Immunol* 2010;135:63–71.
61. Plebani A, Ugazio AG, Meini A, Ruggeri L, Negrini A, Albertini A, et al. Extensive deletion of immunoglobulin heavy chain constant region genes in the absence of recurrent infections: when is IgG subclass deficiency clinically relevant? *Clin Immunol Immunopathol* 1993;68:46–50.
62. Zhao Y, Pan-Hammarstrom Q, Zhao Z, Wen S, Hammarstrom L. Selective IgG2 deficiency due to a point mutation causing abnormal splicing of the Cgamma2 gene. *Int Immunol* 2005;17:95–101.
63. Lim MT, Jeyarajah K, Jones P, Pandya H, Doffinger R, Kumararatne D, et al. Specific antibody deficiency in children with chronic wet cough. *Arch Dis Child* 2012;97:478–80.
64. Javier FC 3rd, Moore CM, Sorensen RU. Distribution of primary immunodeficiency diseases diagnosed in a pediatric tertiary hospital. *Ann Allergy Asthma Immunol* 2000;84:25–30.
65. Carr TF, Koterba AP, Chandra R, Grammer LC, Conley DB, Harris KE, et al. Characterization of specific antibody deficiency in adults with medically refractory chronic rhinosinusitis. *Am J Rhinol Allergy* 2011;25:241–4.
66. Cheng YK, Decker PA, O'Byrne MM, Weiler CR. Clinical and laboratory characteristics of 75 patients with specific polysaccharide antibody deficiency syndrome. *Ann Allergy Asthma Immunol* 2006;97:306–11.
67. Alachkar H, Taubenheim N, Haeney MR, Durandy A, Arkwright PD. Memory switched B cell percentage and not serum immunoglobulin concentration is associated with clinical complications in children and adults with specific antibody deficiency and common variable immunodeficiency. *Clin Immunol* 2006;120:310–18.
68. Van Winkle RC, Hauck WW, McGeady SJ. Phenotypic parameters predict time to normalization in infants with hypogammaglobulinemia. *J Clin Immunol* 2013;33:1336–40.
69. Moschese V, Graziani S, Avanzini MA, Carsetti R, Marconi M, La Rocca M, et al. A prospective study on children with initial diagnosis of transient hypogammaglobulinemia of infancy: results from the Italian Primary Immunodeficiency Network. *Int J Immunopathol Pharmacol* 2008;21:343–52.
70. Inaba H, Hori H, Ito M, Kuze M, Ishiko H, Asmar BI, et al. Polio vaccine virus-associated meningoencephalitis in an infant with transient hypogammaglobulinemia. *Scand J Infect Dis* 2001;33:630–1.
71. Dorsey MJ, Orange JS. Impaired specific antibody response and increased B-cell population in transient hypogammaglobulinemia of infancy. *Ann Allergy Asthma Immunol* 2006;97:590–5.
72. Cipe FE, Dogu F, Guloglu D, Aytakin C, Polat M, Biyikli Z, et al. B-cell subsets in patients with transient hypogammaglobulinemia of infancy, partial IgA deficiency, and selective IgM deficiency. *J Investig Allergol Clin Immunol* 2013;23:94–100.
73. Artac H, Kara R, Gokturk B, Reisli I. Reduced CD19 expression and decreased memory B cell numbers in transient hypogammaglobulinemia of infancy. *Clin Exp Med* 2013;13:257–263.
74. Hirbod-Mobarakeh A, Aghamohammadi A, Rezaei N. Immunoglobulin class switch recombination deficiency type 1 or CD40 ligand deficiency: from bedside to bench and back again. *Exp Rev Clin Immunol* 2014;10:91–105.
75. Cabral-Marques O, Schimke LF, Pereira PV, Falcai A, de Oliveira JB, Hackett MJ, et al. Expanding the clinical and genetic spectrum of human CD40L deficiency: the occurrence of paracoccidioidomycosis and other unusual infections in Brazilian patients. *J Clin Immunol* 2012;32:212–20.
76. Qamar N, Fuleihan RL. The hyper IgM syndromes. *Clin Rev Allergy Immunol* 2014;46:120–30.
77. Durandy A, Kracker S. Immunoglobulin class-switch recombination deficiencies. *Arthritis Res Ther* 2012;14:218.
78. Karaca NE, Durandy A, Gulez N, Aksu G, Kutukculer N. Study of patients with hyper-IgM type IV phenotype who recovered spontaneously during late childhood and review of the literature. *Eur J Pediatr* 2011;170:1039–47.
79. Imai K, Catalan N, Plebani A, Marodi L, Sanal O, Kumaki S, et al. Hyper-IgM syndrome type 4 with a B lymphocyte-intrinsic selective deficiency in Ig class-switch recombination. *J Clin Invest* 2003;112:136–42.
80. Crank MC, Grossman JK, Moir S, Pittaluga S, Buckner CM, Kardava L, et al. Mutations in PIK3CD can cause hyper IgM syndrome (HIGM) associated with increased cancer susceptibility. *J Clin Immunol* 2014;34:272–6.
81. Duraisingham SS, Buckland MS, Grigoriadou S, Longhurst HJ. Secondary antibody deficiency. *Exp Rev Clin Immunol* 2014;10:583–91.
82. Mayilyan KR. Complement genetics, deficiencies, and disease associations. *Protein Cell* 2012;3:487–96.
83. Klein C. Congenital neutropenia. *Hematology* 2009;344–50.
84. Brand PL, Hoving MF, de Groot EP. Evaluating the child with recurrent lower respiratory tract infections. *Paediatr Respir Rev* 2012;13:135–8.
85. Ocampo CJ, Peters AT. Antibody deficiency in chronic rhinosinusitis: epidemiology and burden of illness. *Am J Rhinol Allergy* 2013;27:34–8.
86. Licciardi PV, Balloch A, Russell FM, Burton RL, Lin J, Nahm MH, et al. Pneumococcal polysaccharide vaccine at 12 months of age produces functional immune responses. *J Allergy Clin Immunol* 2012;129:794–800.e2.
87. Carneiro-Sampaio MM, Grumach AS, Manissadjian A. Laboratory screening for the diagnosis of children with primary immunodeficiencies. *J Investig Allergol Clin Immunol* 1991;1:195–200.
88. Centers for Disease C. Prevention. Licensure of a 13-valent pneumococcal conjugate vaccine (PCV13) and recommendations for use among children – Advisory Committee on Immunization Practices (ACIP), 2010. *MMWR Morb Mortal Wkly Rep* 2010;59:258–61.
89. Paris K, Sorensen RU. Assessment and clinical interpretation of polysaccharide antibody responses. *Ann Allergy Asthma Immunol* 2007;99:462–4.
90. Orange JS, Ballow M, Stiehm ER, Ballas ZK, Chinen J, De La Morena M, et al. Use and interpretation of diagnostic vaccination in primary immunodeficiency: a working group report of the Basic and Clinical Immunology Interest Section of the American Academy of Allergy, Asthma & Immunology. *J Allergy Clin Immunol* 2012;130(Suppl. 3):S1–24.
91. Broides A, Yang W, Conley ME. Genotype/phenotype correlations in X-linked agammaglobulinemia. *Clin Immunol* 2006;118:195–200.
92. Lopez-Granados E, Perez de Diego R, Ferreira Cerdan A, Fontan Casariego G, Garcia Rodriguez MC. A genotype-phenotype correlation study in a group of 54 patients with X-linked agammaglobulinemia. *J Allergy Clin Immunol* 2005;116:690–7.

93. Kuruvilla M, de la Morena MT Antibiotic prophylaxis in primary immune deficiency disorders. *J Allergy Clin Immunol Pract* 2013; 1:573–82.
94. Ballou M. Optimizing immunoglobulin treatment for patients with primary immunodeficiency disease to prevent pneumonia and infection incidence: review of the current data. *Ann Allergy Asthma Immunol* 2013;111(Suppl. 6):S2–5.
95. Papadopoulou-Alataki E, Hassan A, Davies EG. Prevention of infection in children and adolescents with primary immunodeficiency disorders. *Asian Pac J Allergy Immunol* 2012;30: 249–58.
96. Prasse A, Kayser G, Warnatz K. Common variable immunodeficiency-associated granulomatous and interstitial lung disease. *Curr Opin Pulm Med* 2013;19:503–9.
97. Chase NM, Verbsky JW, Hintermeyer MK, Waukau JK, Tomita-Mitchell A, Casper JT, et al. Use of combination chemotherapy for treatment of granulomatous and lymphocytic interstitial lung disease (GLILD) in patients with common variable immunodeficiency (CVID). *J Clin Immunol* 2013;33:30–9.
98. Rizzi M, Neumann C, Fielding AK, Marks R, Goldacker S, Thaventhiran J, et al. Outcome of allogeneic stem cell transplantation in adults with common variable immunodeficiency. *J Allergy Clin Immunol* 2011;128:1371–4.e2.

# T Cell Immunodeficiencies

LUIGI D. NOTARANGELO

## KEY POINTS

- Defects of T cell development and/or function cause increased susceptibility to infections of bacterial, viral and fungal origin, and are often associated with autoimmune manifestations and malignancies.
- The most severe forms of these disorders, severe combined immunodeficiency (SCID), are fatal unless immune reconstitution is attained, typically with hematopoietic stem cell transplantation (HSCT) or in selected cases with gene therapy or enzyme replacement therapy.
- Newborn screening based on enumeration of T cell receptor excision circles (TRECs) permits early identification of SCID and thereby allows adoption of therapeutic interventions aimed to reduce the risk of infection while preparing for HSCT, resulting in improved overall survival.
- Several forms of T cell immunodeficiency are associated with other hematopoietic and non-hematopoietic defects, whose severity may have a significant impact on prognosis and outcome.
- Hygiene measures, antimicrobial prophylaxis, regular immunoglobulin replacement therapy and nutritional support are cardinal aspects of treatment for patients with T cell deficiencies, along with HSCT.

T lymphocytes are an essential component of adaptive immunity. Through cytolytic activity and secretion of  $T_H1$  (interferon [IFN]- $\gamma$ ) and  $T_H17$  (interleukin [IL]-17, -22) cytokines they mediate resistance to viruses, mycobacteria and fungi. In addition, interaction of  $T_H2$  cells with B lymphocytes and antigen-presenting cells, and release of soluble mediators such as IL-4 and IL-10 promote T-dependent antibody responses and contribute to defense against extracellular pathogens. Consequently, defects in T cell development and/or function result in severe combined immunodeficiency (SCID), with increased susceptibility to severe infections from early in life.<sup>1</sup>

In addition, impaired development and/or function of regulatory T ( $T_{REG}$ ) lymphocytes, which play a crucial role in immune homeostasis, causes autoimmunity. This chapter will discuss the etiology, clinical presentation, diagnostic approach and main principles of treatment for congenital T cell disorders. For a more detailed discussion of hematopoietic stem cell transplantation (HSCT) and gene therapy the reader is referred to Chapter 16.

## Severe Combined Immunodeficiency

### ETIOLOGY

SCID is a heterogeneous group of disorders that present with a distinct immunologic phenotype (Table 9-1). Molecular and cellular mechanisms responsible for SCID include:

- *Defects of lymphocyte survival:* adenosine deaminase (ADA) deficiency, reticular dysgenesis
- *Signaling defects:* X-linked SCID, JAK3 deficiency, IL-7R deficiency, CD45 deficiency
- *Defects of expression and signaling through the pre-T cell receptor (pre-TCR) and the TCR:* defects of RAG1, RAG2, Artemis, Cernunnos, DNA ligase IV (LIG4), DNA protein kinase catalytic subunit (DNA-PKcs), defects of CD3 chains (CD3 $\delta$ , CD3 $\epsilon$ , CD3 $\zeta$ ), defect of TCR  $\alpha$  constant (TRAC) chain, CD45 deficiency.

Hypomorphic mutations in these genes may allow for residual T cell development, with or without immune dysregulation. These conditions, and other defects at later stages in T cell development, will be discussed separately in this chapter (see ‘Other Combined Immunodeficiencies’).

### SCID Caused by Adenosine Deaminase Deficiency

Adenosine deaminase (ADA) mediates conversion of adenosine into inosine, and of deoxyadenosine into deoxyinosine. Deficiency of ADA, inherited as an autosomal recessive trait, accounts for 5% to 10% of all cases of SCID. Lack of ADA results in intracellular accumulation of deoxyadenosine and of its phosphorylated metabolites, among which dATP is particularly toxic to lymphoid precursors.<sup>2</sup> Consequently, complete ADA deficiency is characterized by extreme lymphopenia ( $T^+ B^- NK^-$  SCID) and extra-immune manifestations (reflecting the housekeeping nature of the ADA gene) from early in life. However, partial defects of the enzyme may result in less severe clinical presentation (delayed or late-onset forms) that may even present in adulthood.<sup>3</sup>

### Reticular Dysgenesis

This rare form of autosomal recessive SCID is characterized by severe lymphopenia and agranulocytosis, associated with sensorineural deafness.<sup>4</sup> The disease is caused by mutations of the AK2 gene, encoding for adenylate kinase 2 that controls intramitochondrial levels of ADP. AK2 deficiency results in increased cell death in lymphoid progenitors and in myeloid precursors committed to neutrophil differentiation.<sup>5,6</sup>

### X-Linked Severe Combined Immunodeficiency (SCIDX1, $\gamma C$ Deficiency)

SCIDX1 is the most common form of SCID in humans, with an estimated incidence of 1 : 100,000 to 1 : 150,000 live births. Inherited as an X-linked trait, it is characterized by complete absence



TABLE  
9-1

## Genetic and Immunologic Features of Combined Immune Deficiency

Disease	Gene	Inheritance	CIRCULATING LYMPHOCYTES		
			T	B	NK
B <sup>-</sup> SCID					
Reticular dysgenesis	<i>AK2</i>	AR	↓↓	↓	↓↓
RAG deficiency	<i>RAG1, RAG2</i>	AR	↓↓	↓↓	N
Radiation-sensitive SCID	<i>DCLRE1C (Artemis)</i>	AR	↓↓	↓↓	N
	<i>PRKDC</i>	AR	↓↓	↓↓	N
	<i>LIG4</i>	AR	↓↓	↓↓	N
	<i>NHEJ1</i>	AR	↓↓	↓	N
T <sup>-</sup> B <sup>+</sup> SCID					
X-linked SCID	<i>IL2RG</i>	XL	↓↓	N	↓↓
JAK-3 deficiency	<i>Jak-3</i>	AR	↓↓	N	↓↓
IL-7R $\alpha$ deficiency	<i>IL7RA</i>	AR	↓↓	N	N
CD45 deficiency	<i>CD45</i>	AR	↓↓	N/↓	↓
CD3 $\delta$ , CD3 $\epsilon$ , or CD3 $\zeta$ deficiency	<i>CD3D, CD3E, CD3Z</i>	AR	↓↓	N	N
Coronin-1A deficiency	<i>CORO1A</i>	AR	↓naive	N	N
Purine metabolism deficiency					
Adenosine deaminase deficiency	<i>ADA</i>	AR	↓↓	↓	↓
Nucleoside phosphorylase deficiency	<i>PNP</i>	AR	↓↓	↓/N	↓/N
Omenn syndrome					
	<i>RAG1, RAG2, DCLRE1C, LIG4, ADA, AK2</i>	AR	↓/N	↓↓	N
	<i>IL7R, RMRP</i>	AR	↓/N	N	N
	<i>IL2RG</i>	XL	↓/N	N	↓↓
	<i>ZAP70</i>	AR	↓ (↓↓ CD8)	N	N
TCR $\alpha$ constant chain deficiency	<i>TRAC</i>	AR	↓ (almost all T cells are TCR $\gamma\delta$ <sup>+</sup> )	N	N
ZAP-70 deficiency	<i>ZAP70</i>	AR	↓ (↓↓ CD8)	N	N
LCK deficiency	<i>LCK</i>	AR	N (↓↓ CD4 naive)	N	N
RHOH deficiency	<i>RHOH</i>	AR	↓↓ naive T cells	N	N
MST1 deficiency	<i>STK4</i>	AR	↓↓ naive T cells, ↑ T <sub>EMRA</sub> and Teff	N	N
ITK deficiency	<i>ITK</i>	AR	Progressive ↓	N	N
DOCK8 deficiency	<i>DOCK8</i>	AR	↓	N, ↓memory B cells	N
Calcium flux defects					
Stim1 deficiency	<i>STIM1</i>	AR	N	N	N
Orai1 deficiency	<i>ORAI1</i>	AR	N	N	N
Mg <sup>2+</sup> flux deficiency	<i>MAGT1</i>	XL	↓CD4	N	N (impaired function)
CD25 deficiency	<i>IL2RA</i>	AR	↓	N	N
STAT5b deficiency	<i>STAT5B</i>	AR	↓	N	N
Human 'nude' phenotype	<i>FOXN1</i>	AR	↓↓	N	N
MALT1 deficiency	<i>MALT1</i>	AR	N	N	N
CARD11 deficiency	<i>CARD11</i>	AR	N(↓memory T)	N (mostly transitional)	N
IKBKB deficiency	<i>IKBKB</i>	AR	N(↓memory T)	N (↓↓memory B)	N
Activated PI3K- $\delta$	<i>PI3KCD</i>	AD	↓CD4, ↑ T <sub>EMRA</sub>	↓	N
IL-21R deficiency	<i>IL21R</i>	AR	N	N (↓memory B)	N
CD27 deficiency	<i>CD27</i>	AR	N	N (↓↓memory B)	N
MHC class I deficiency	<i>TAP1, TAP2, TAPBP</i>	AR	↓ (↓↓CD8)	N	N
MHC class II deficiency	<i>CIITA, RFXANK, RFX5, RFXAP</i>	AR	↓ (↓↓CD4)	N	N
CTPS1 deficiency	<i>CTPS1</i>	AR	↓CD4	N (↓memory B)	N
X-linked hyper-IgM syndrome	<i>CD40LG</i>	XL	N	N	N
ID with multiple intestinal atresia	<i>TTC7A</i>	AR	↓	↓	N
Cartilage hair hypoplasia	<i>RMRP</i>	AR	↓/N	N	N
Schimke syndrome	<i>SMARCAL1</i>	AR	↓	N	N

T – T lymphocytes, B – B lymphocytes, NK – natural killer lymphocytes, AR – autosomal recessive, XL – X-linked, N – normal.

of both T and NK lymphocytes, with preserved number of B lymphocytes ( $T^- B^+ NK^-$  SCID). The disease is caused by mutations in the *IL2RG* gene that encodes for the IL2 receptor common gamma chain ( $IL-2R\gamma_c$ ,  $\gamma_c$ ).<sup>7</sup> The  $\gamma_c$  chain is constitutively expressed by T, B and NK cells, as well as myeloid cells and other cell types, including keratinocytes. The  $\gamma_c$  protein is an integral component of various cytokine receptors, namely IL-2R, IL-4R, IL-7R, IL-9R, IL-15R and IL-21R. In all of these receptors, the  $\gamma_c$  is coupled with the intracellular tyrosine kinase Janus-associated kinase (JAK)-3, that mediates signal transduction.<sup>8</sup> Lack of circulating T and NK cells in SCIDX1 males reflects defective signaling through IL-7R and IL-15R, respectively.

#### JAK-3 Deficiency

JAK-3 is a cytoplasmic tyrosine kinase that is physically and functionally associated with the  $\gamma_c$  in all of the  $\gamma_c$ -containing cytokine receptors.<sup>9</sup> Mutations of the *JAK3* gene result in a clinical and immunologic phenotype (i.e.  $T^- B^+ NK^-$  SCID) that is undistinguishable from SCIDX1,<sup>10,11</sup> but has an autosomal pattern of inheritance.

#### IL-7R $\alpha$ Deficiency

IL-7R $\alpha$  deficiency results in an autosomal recessive form of SCID characterized by lack of circulating T lymphocytes, with preserved number of B and NK cells ( $T^- B^+ NK^+$  SCID).<sup>12</sup> IL-7 is produced by stromal cells in bone marrow and in the thymus, and provides survival and proliferative signals to IL-7R $^+$  lymphoid progenitor cells.

#### $T^- B^-$ SCID Caused by Defective VDJ Recombination

B and T lymphocytes recognize foreign antigen through specialized receptors, the immunoglobulin (Ig) and the T cell receptor (TCR), respectively. These receptors are encoded by variable/diversity/joining (VDJ) gene segments that undergo somatic rearrangement through a mechanism known as VDJ recombination.<sup>13</sup> This process is initiated when the lymphoid-specific recombinase activating gene 1 (*RAG1*) and *RAG2* proteins recognize specific recombination signal sequences (RSS) that flank each of the V, D and J gene elements and introduce a DNA double-strand break in this region.<sup>14</sup> Subsequently, a series of ubiquitously expressed proteins (including Ku70, Ku80, DNA-PKcs, XRCC4, DNA ligase IV, Artemis and Cernunnos/XLF) involved in recognition and repair of DNA damage mediate the final steps of the VDJ recombination process.

Defects of V(D)J recombination cause complete absence of both T and B lymphocytes, with preserved presence of NK cells ( $T^- B^- NK^+$  SCID). *RAG1* and *RAG2* mutations do not affect mechanisms of DNA double-strand break (dsb) repair and hence are not associated with increased cellular radiosensitivity.<sup>15</sup> By contrast, defects of Artemis, *LIG4*, Cernunnos/XLF or DNA-PKcs cause increased radiosensitivity, reflecting impaired dsb repair.<sup>16-20</sup> Of note, hypomorphic mutations in the *RAG1/2* genes and in the Artemis-encoding *DCLRE1C* gene have been associated with variable clinical and immunologic phenotypes, ranging from Omenn syndrome to expansion of TCR $\gamma\delta^+$  T cells to delayed onset immunodeficiency with granuloma and/or autoimmunity.<sup>21,22</sup>

#### CD3/TCR Deficiencies

The CD3 complex consists of CD3 $\gamma$ ,  $\delta$ ,  $\epsilon$  and  $\zeta$  chains and is required to mediate signaling through the pre-TCR and the

TCR. In humans, defects of the CD3  $\delta$ ,  $\epsilon$  or  $\zeta$  chains cause autosomal recessive  $T^- B^+ NK^+$  SCID.<sup>23-25</sup> In contrast, CD3 $\gamma$  deficiency is associated with a partial T cell lymphopenia and a variable clinical phenotype.<sup>26,27</sup>

#### CD45 Deficiency

Two unrelated patients have been reported in whom SCID was caused by the complete absence of the CD45 protein, a phosphatase that modulates signaling through the TCR/CD3 complex.<sup>28,29</sup> The immunologic phenotype is characterized by complete lack of T cells, with normal to increased B cell counts.

### OTHER COMBINED IMMUNODEFICIENCIES

#### Omenn Syndrome and Other Conditions Associated with Hypomorphic RAG Mutations

Omenn syndrome (OS) is a combined immunodeficiency characterized by generalized erythroderma, lymphadenopathy, hepatosplenomegaly, respiratory infections, diarrhea, failure to thrive, hypoproteinemia with edema, and eosinophilia<sup>30</sup> (Figure 9-1). IgE serum levels are often elevated, and T lymphocytes have an oligoclonal repertoire.

In most cases, OS is due to hypomorphic mutations in *RAG1* and *RAG2* genes,<sup>31</sup> however it may be caused also by hypomorphic defects in other genes, including *DCLRE1C*,<sup>32</sup> *IL7R*,<sup>33</sup> *LIG4*,<sup>34</sup> *RMRP*,<sup>35</sup> *IL2RG*,<sup>36</sup> *ADA*,<sup>37</sup> *ZAP70*<sup>38</sup> and *AK2*.<sup>39</sup> Impaired thymic expression of AIRE, a transcription factor involved in expression and presentation of self-antigens, has been reported in patients with OS, and may favor survival of autoreactive T cell clones.<sup>40</sup>



**Figure 9-1** Typical clinical features in an infant with Omenn syndrome. Note generalized erythroderma with scaly skin, alopecia and edema.

Patients with hypomorphic mutations in the *RAG1/2* genes may also present with other clinical and immunologic phenotypes. Expansion of TCR $\gamma\delta^+$  T cells has been frequently reported after cytomegalovirus (CMV) infection and may associate with autoimmunity (especially cytopenias).<sup>41,42</sup> In other cases, RAG deficiency may present with granulomatous lesions and/or autoimmunity.<sup>21,22,43</sup> The severity of the clinical phenotype of RAG deficiency correlates, at least in part, with the residual levels of recombination activity of the mutant protein.<sup>44</sup> However, environmental factors are also important, because patients with similarly severe mutations may present with distinct phenotypes.<sup>45</sup>

### Nucleoside Phosphorylase Deficiency

Purine nucleoside phosphorylase (PNP) converts guanosine into guanine and deoxyguanosine to deoxyguanine. Autosomal recessive PNP deficiency causes accumulation of phosphorylated deoxyguanosine metabolites (and of dGTP in particular) that inhibit ribonucleotide reductase, whose activity is essential to DNA synthesis. PNP deficiency is particularly deleterious to developing T lymphocytes and to central nervous system cells, causing severe T cell lymphopenia and neurologic deterioration.<sup>46</sup>

### TCR $\alpha$ Constant Chain (TRAC) Gene Defect

A homozygous splice-site mutation of the TCR $\alpha$  constant (*TRAC*) gene, causing loss of the transmembrane and intracytoplasmic domain, has been reported in two patients.<sup>47</sup> All T cells expressing CD3 at normal density coexpressed TCR $\gamma\delta$ ; an unusual population of CD3<sup>low</sup> T cells expressed TCR $\alpha\beta$ . In vitro lymphocyte proliferation to mitogens and antigens was decreased.

### Defects of TCR Signaling

Stimulation of T cells through TCR results in activation of the p56lck kinase, which mediates tyrosine phosphorylation of immunoreceptor tyrosine-based activation motifs (ITAMs) in the CD3- $\gamma$ , - $\delta$ , - $\epsilon$  and - $\zeta$  chains. The Zeta-associated protein of 70 kDa (ZAP-70) is then recruited to the CD3/TCR complex,<sup>47</sup> allowing activation of downstream signaling molecules such as linker for activation of T cells (LATs) and SLP-76.<sup>48</sup> Autosomal recessive ZAP-70 deficiency is characterized by lack of CD8<sup>+</sup> T cells; CD4<sup>+</sup> T lymphocytes are present but nonfunctional.<sup>49-51</sup>

Deficiency of p56lck has been demonstrated in a child with recurrent infections and autoimmunity, associated with CD4<sup>+</sup> T cell lymphopenia, oligoclonal T cell repertoire and impaired T cell proliferation.<sup>52</sup>

The Ras homolog family member H (*RHOH*) is a small GTPase that plays an important role in T cell activation. A homozygous nonsense mutation of the *RHOH* gene in two young adult siblings was associated with marked reduction of naïve CD4<sup>+</sup> T cells, restricted T cell repertoire, expansion of memory T cells, including T<sub>EMRA</sub> (CD8<sup>+</sup> CD45RA<sup>+</sup> CCR7<sup>-</sup> CD244<sup>+</sup>) cells, and impaired in vitro T cell proliferation.<sup>53</sup> The clinical phenotype was characterized by warts, Burkitt's lymphoma, psoriatic-like skin rash and lung granulomatous disease.

The macrophage stimulating 1 (MST1) molecule is involved in intracellular signaling. Patients with MST1 deficiency show increased susceptibility to recurrent bacterial and viral infections (including warts and molluscum contagiosum), as well as autoimmunity, associated with severe reduction of naïve T cells, increased proportion of CD8<sup>+</sup> T<sub>EMRA</sub> cells, restricted T

cell repertoire, impaired proliferation to mitogens, increased apoptosis of T lymphocytes and reduced number of memory B cells.<sup>54-56</sup>

The interleukin-2-inducible T cell kinase (ITK) is activated in response to TCR stimulation and participates in intracellular signaling. ITK deficiency is characterized by increased risk of infections (especially due to herpesviruses) and prominent immune dysregulation, associated with a reduced number of naïve CD4<sup>+</sup> cells, defective T cell proliferation and progressive hypogammaglobulinemia. There is an increased risk of Epstein-Barr virus (EBV)-driven lymphoproliferative disease, with frequent pulmonary involvement.<sup>57-60</sup>

### DOCK8 Deficiency

The dedicator of cytokinesis 8 (*DOCK8*) protein plays an important role in intracellular signaling and cytoskeleton reorganization. Mutations of the *DOCK8* gene cause a severe autosomal recessive immunodeficiency, with increased incidence of skin abscesses, mucocutaneous candidiasis and especially cutaneous viral infections, eczema, severe food allergy and markedly elevated IgE levels and eosinophilia.<sup>61,62</sup> There is a high risk of human papillomavirus (HPV)-associated squamous cell carcinoma. Vascular thrombosis in the central nervous system, autoimmune cytopenias and other autoimmune manifestations have been also reported. The immunologic phenotype is characterized by multiple abnormalities,<sup>61-68</sup> with reduced number of naïve T cells, increased proportion of CD8<sup>+</sup> T<sub>EMRA</sub> cells, and defective in vitro T cell proliferation to CD3/CD28 stimulation. Deficiency of T<sub>H</sub>17 cells accounts for the increased risk of candidiasis. Migration of T cells and dendritic cells to inflamed/infected tissues is defective. NK and NKT cell function is also compromised. Immunoglobulin levels are variable, although low serum IgM levels are frequently seen. B cell response to TLR9 activation is severely compromised. Antibody responses to T-dependent antigens may be initially normal, but are not sustained over time. The disease has a dismal prognosis, but can be treated by HSCT.<sup>69</sup>

### Human 'Nude' Phenotype (*FOXP1* Defect)

FOXP1 is a transcription factor that controls development of thymic epithelial cells. Mutations of the *FOXP1* gene cause a severe T cell immunodeficiency with complete lack of CD8<sup>+</sup> T cells, associated with alopecia.<sup>70</sup> Treatment is based on thymus transplantation.<sup>71</sup>

### Coronin-1A Deficiency

Coronin-1A is an actin regulator that regulates T cell survival and migration. Mutations of the *CORO1A* gene cause immunodeficiency with increased risk of EBV lymphoproliferative disease, associated with profound naïve T cell lymphopenia, oligoclonal T cell repertoire and severe reduction of iNKT cells and mucosa-associated invariant T (MAIT) cells.<sup>72,73</sup>

### Major Histocompatibility Complex (MHC) Class II Deficiency

Lack of MHC class II molecules expression on the surface of thymic epithelial cells results in an inability to positively select CD4<sup>+</sup> thymocytes and, hence, in the very low number of circulating CD4<sup>+</sup> lymphocytes. In addition, the ability to mount antibody responses is also impaired.

MHC class II deficiency has an autosomal recessive pattern of inheritance and may be caused by mutations in



the *CIITA*, *RFXANK*, *RFX5* and *RFXAP* genes, which encode for transcription factors that govern MHC class II antigen expression.<sup>74–77</sup>

### MHC Class I Deficiency

Human leukocyte antigen (HLA) class I molecules play an essential role in presenting antigenic peptides to cytotoxic T lymphocytes and in modulating the activity of natural killer (NK) cells. HLA class I molecules are composed of a polymorphic heavy chain, associated with  $\beta$ 2-microglobulin ( $\beta$ 2M). The assembly of HLA class I molecules occurs in the lumen of the endoplasmic reticulum (ER), where they are loaded with peptides derived from the degradation of intracellular organisms. These peptides are transported into the ER via transporter associated with antigen presentation (TAP) proteins.<sup>78</sup> TAP consists of two structurally related subunits (TAP1 and TAP2). In addition, the tapasin protein plays an important role in the loading process. Defects in TAP1, TAP2 or tapasin result in impaired peptide-HLA class I/ $\beta$ 2M complex formation with reduced surface expression of HLA class I molecules. Patients with MHC class I deficiency have recurrent sinopulmonary infections and deep skin ulcers, associated with a reduced number of circulating CD8<sup>+</sup> T cells.<sup>79–81</sup>

### Deficiency of Calcium-Release Activated Channels (CRAC) and of Magnesium Flux

Lymphocyte activation depends on calcium mobilization. In particular, TCR-induced activation results in release of Ca<sup>2+</sup> from the ER stores. Depletion of these Ca<sup>2+</sup> stores is sensed by the STIM proteins, which oligomerize and bind to the ORAI proteins that form the pore of the Ca<sup>2+</sup>-release activated channels (CRAC) located in the cell membrane, allowing Ca<sup>2+</sup> entry. Mutations of the *STIM1* and *ORAI1* genes cause an autosomal recessive immunodeficiency with increased risk of infections, hypogammaglobulinemia, impaired antibody responses and profoundly reduced in vitro T cell proliferation.<sup>82–84</sup> Autoimmune manifestations (especially cytopenias) are common, in particular in patients with *STIM1* deficiency. Extra-immune manifestations include nonprogressive myopathy and ectodermal dysplasia.

The magnesium transporter 1 (*MAGT1*) protein conducts Mg<sup>2+</sup> across the cell membrane, allowing downstream signaling. Mutations of the X-linked *MAGT1* gene in humans cause immunodeficiency with increased susceptibility to viral and bacterial infections, and to EBV-driven lymphoproliferative disease.<sup>85,86</sup> CD4<sup>+</sup> T cell lymphopenia has been frequently observed. NK cytolytic activity in response to NKG2D engagement is reduced.<sup>87</sup>

### Immunodeficiency with Immune Dysregulation due to Impaired IL-2 Signaling

IL-2 signaling maintains peripheral immune homeostasis. Deficiency of the  $\alpha$  chain of the IL-2 receptor (IL-2R $\alpha$ , CD25) causes immune dysregulation and lymphoproliferation, often associated with early-onset viral and bacterial infections, oral thrush and chronic diarrhea, associated with lymphadenopathy and hepatosplenomegaly.<sup>88,89</sup>

STAT5b is a transcription factor that is activated in response to growth hormone (GH) and cytokines, including IL-2. STAT5b deficiency is characterized by short stature with GH insensitivity, and a variable degree of immune deficiency and immune dysregulation.<sup>90</sup>

### IL-21 Receptor (IL-21R) Deficiency

Loss-of-function mutations of IL-21R have been reported in four patients with sclerosing cholangitis due to *Cryptosporidium*, recurrent pneumonia, chronic diarrhea and failure to thrive.<sup>91</sup> The proportion of switched memory B cells was reduced. T cell proliferation to mitogens was preserved, but proliferation to antigens was impaired.

### CD27 Deficiency

CD27 is a costimulatory molecule. *CD27* mutations are responsible for an autosomal recessive combined immunodeficiency with EBV lymphoproliferative disease, reduced T cell proliferation to mitogens and antigens, and progressive hypogammaglobulinemia.<sup>92,93</sup>

### T cell Defects with Impaired NF- $\kappa$ B Activation

The MALT1, BCL-10, and CARD11 proteins form a complex that is activated in response to TCR stimulation, allowing nuclear translocation of NF- $\kappa$ B. Autosomal recessive *MALT1* deficiency causes recurrent bacterial, viral and fungal infections.<sup>94</sup> In spite of normal T and B lymphocyte count, proliferative responses to CD3 stimulation and antigens are decreased, and specific antibody responses are also impaired.

*CARD11* deficiency causes increased susceptibility to opportunistic infections.<sup>95,96</sup> A reduced number of memory T cells, and hypogammaglobulinemia with increased proportion of transitional B cells are present.

Mutations of the *IKKBK* gene, encoding for the IKK $\beta$  component of the IKK complex, have been reported in four unrelated infants with early-onset infections and hypogammaglobulinemia.<sup>97</sup> Immunologic abnormalities included lack of memory T and B cells and of T<sub>REG</sub> lymphocytes, and defective in vitro T cell proliferation to CD3 stimulation.

### Immunodeficiency due to Activating PI3K- $\delta$ Mutations

Phosphatidylinositol-3-OH kinases (PI3K) include a series of molecules that participate in cell signaling, enabling generation of PIP<sub>3</sub> from PIP<sub>2</sub>, and activation of mTOR and AKT. Heterozygous, gain-of-function mutations of the *PI3KCD* gene, encoding for the p110 $\delta$  subunit of phosphatidylinositol-3-OH kinase (PI3K), cause increased susceptibility to recurrent respiratory tract infections, EBV lymphoproliferative disease (frequently associated with hepatosplenomegaly and lymphadenopathy) and CMV viremia.<sup>98–100</sup> Reduction of naïve CD4<sup>+</sup> cells, expansion of memory and T<sub>EMRA</sub> CD8<sup>+</sup> cells, and decreased number of switched memory B cells have been reported. IgM serum levels are increased. Constitutive activation of AKT is associated with increased activation-induced cell death of patients' lymphocytes. Treatment with rapamycin, an mTOR inhibitor, may reduce lymphoproliferation and organomegaly.

### Cytidine 5' Triphosphate Synthase 1 (CTPS1) Deficiency

Autosomal recessive mutations of the *CTPS1* gene, involved in the synthesis of cytidine 5' triphosphate (CTP), cause early-onset viral and bacterial infections and an increased risk of EBV-driven non-Hodgkin B cell lymphoma, associated with CD4 lymphopenia, increased proportion of effector memory T cells, absence of iNKT and MAIT lymphocytes, impaired



**BOX 9-1 KEY CONCEPTS****Clinical and Laboratory Elements in the Diagnosis of SCID****CLINICAL FEATURES**

- Positive family history (X-linked, other siblings affected, parental consanguinity)
- Presentation early in life (within the first 4 to 6 months of age)
- Severe respiratory infections (interstitial pneumonia)
- Protracted diarrhea
- Failure to thrive
- Persistent candidiasis
- Skin rash, erythroderma may be present

**DIAGNOSTIC CRITERIA (ELABORATED BY THE PIDTC)<sup>102</sup>****Typical SCID**

- Absence or very low number of T cells (CD3<sup>+</sup> cells <300/μL) and
- Absent or very low T cell function (PHA response <10% of lower limit of normal)

OR

- T cells of maternal origin present

**Omenn Syndrome**

- Generalized skin rash
- Absence of maternal engraftment
- Autologous T cells detectable, ≥300/μL
- Absent or low (≤30% of normal) T cell proliferation to recall antigens<sup>a</sup>

**Leaky SCID**

- Reduced number of autologous T cells (<1,000/μL for up to 2 years; <800/μL for age >2 up to 4 years; <600/μL for age >4 years)
- Absence of maternal engraftment
- Low T cell function (PHA response <30% of lower limit of normal)

**Reticular Dysgenesis**

- Absence or very low number of T cells (CD3<sup>+</sup> cells <300/μL)
- No or very low T cell function (PHA response <10% of lower limit of normal)
- Severe neutropenia (absolute neutrophil count <200 cells/μL)
- Sensorineural deafness and/or absence of granulopoiesis at bone marrow examination and/or a deleterious *AK2* mutation

<sup>a</sup>If proliferation to antigens was not tested, the diagnosis of Omenn syndrome can be supported by the presence of at least four of the following criteria, at least one of which must be among those marked by an asterisk: hepatomegaly; splenomegaly; increased IgE level; increased absolute eosinophil count; \*oligoclonal T cells; \*>80% of the CD3<sup>+</sup> or CD4<sup>+</sup> T cells are CD45R0<sup>+</sup>; \*PHA response <30% of lower limit of normal; \*proliferative response in mixed leukocyte reaction is <30% of lower limit of normal; \*mutation in SCID-causing gene.

proliferation to mitogens and antigens, and reduced number of memory B cells.<sup>101</sup>

**DIFFERENTIAL DIAGNOSIS OF SCID AND OTHER COMBINED IMMUNODEFICIENCIES**

SCID and other combined immunodeficiencies are characterized by typical clinical signs (Box 9-1), with early-onset severe infections sustained by bacteria, viruses and fungi, including opportunistic pathogens (such as *Pneumocystis jirovecii*, CMV), and growth failure<sup>103</sup> (Figure 9-2). Skin manifestations (rash,



**Figure 9-2** Typical appearance of an infant with severe combined immunodeficiency (SCID). Note severe growth failure and respiratory distress.

generalized erythroderma, alopecia) are also common and may reflect the presence of autoreactive T cell clones (such as in OS) or true graft-versus-host disease (GvHD) caused by transplacental passage of alloreactive maternal T lymphocytes.<sup>104</sup> Other manifestations of maternal T cell engraftment include liver dysfunction, cytopenia (as a result of bone marrow aggression) and eosinophilia.<sup>104</sup>

Typical clinical and laboratory features are present in some forms of SCID. Cupping and flaring of the ribs and liver dysfunction are often present in ADA deficiency.<sup>105</sup> Autoimmune hemolytic anemia and regression of psychomotor skills are observed in PNP deficiency.<sup>106</sup> Sensorineural deafness is part of reticular dysgenesis,<sup>4</sup> whereas microcephaly and growth abnormalities are seen in patients with defects of DNA repair.<sup>16,18,19</sup> Alopecia is observed in patients with FOXN1 deficiency.<sup>69</sup> Non-progressive myopathy is a characteristic feature of CRAC channel defects. Severe food allergy is common in DOCK8 deficiency. Autoimmunity is a hallmark of CD25 or STAT5B deficiencies, as well as of defects of Ca<sup>2+</sup> signaling (especially STIM1), but is frequently seen also in patients with RAG mutations.

SCID is a medical emergency. Therefore, all infants with a possible diagnosis of SCID need to be carefully and rapidly evaluated by means of appropriate laboratory assays (see Box 9-1 and below) and careful family history. The differential diagnosis includes other conditions with increased risk of infections (congenital heart disease, pulmonary defects, cystic fibrosis, HIV infection and other secondary immune deficiencies). For patients with generalized erythroderma due to Omenn syndrome or to maternal T cell engraftment, the differential diagnosis includes severe allergy, ichthyosis, IPEX (immune dysregulation, polyendocrinopathy, enteropathy, X-linked)<sup>107</sup> and Netherton's syndrome.

**EVALUATION AND MANAGEMENT**

A correct diagnosis of SCID should be established as soon as possible in order to offer an optimal perspective on treatment. TRECs are a by-product of V(D)J recombination and are present in newly generated T lymphocytes. No or low levels of TRECs are detected in infants with SCID, and newborn screening for SCID based on enumeration of TRECs in dried blood spots collected at birth is currently widely used in the USA.<sup>108</sup> However, confirmation of SCID requires additional tests. Severe lymphopenia is observed in most SCID infants.<sup>109</sup> However, a

normal (or nearly normal) number of lymphocytes may be seen in some forms of combined immunodeficiency (OS, MHC class II deficiency, ZAP-70 deficiency) or in infants with maternal T cell engraftment. In most cases, enumeration of total (CD3<sup>+</sup>) T lymphocytes, CD4<sup>+</sup> and CD8<sup>+</sup> T cell subsets (including analysis of naïve T cells), B (CD19<sup>+</sup>) lymphocytes and NK (CD16<sup>+</sup>) cells will reveal the diagnosis of SCID and also orient toward specific gene defects. Early in life the vast majority of T lymphocytes are naïve T cells (CD45RA<sup>+</sup>); by contrast, patients with OS or with maternal T cell engraftment show an increased proportion of activated/memory (CD45RO<sup>+</sup>) T cells. Moreover, in vitro lymphocyte proliferation to mitogens is markedly reduced in patients with SCID, including those with maternal T cells. Selective deficiency of CD4<sup>+</sup> lymphocytes may suggest MHC class II deficiency, whereas deficiency of CD8<sup>+</sup> T cells is observed in ZAP-70 deficiency and in MHC class I deficiency.

Measurement of enzymatic ADA and PNP activity, and of dATP and dGTP levels in red blood cells, is important to reach a final diagnosis of ADA or PNP deficiency.

Distinguishing typical SCID from leaky forms of the disease has important implications. Patients with persistence of autologous, partially functioning, T cells typically require use of chemotherapy in preparation for HSCT, whereas no conditioning is strictly required in babies with SCID. The Primary Immune Deficiency Treatment Consortium (PIDTC) has identified criteria to distinguish SCID from atypical forms of the disease.<sup>102</sup>

Ultimately, mutation analysis represents an important diagnostic tool to confirm the diagnosis of SCID and related disorders (Table 9-1).

## TREATMENT

Optimal treatment of SCID is based on HSCT, as discussed in greater detail in Chapter 16. Prior to HSCT, SCID infants need to be protected from infections (Box 9-2). Prophylactic trimethoprim-sulfamethoxazole is effective in preventing *P. jirovecii* pneumonia (PJP). Regular administration of intravenous immunoglobulins, reinforcement of hygiene measures,

### BOX 9-2 THERAPEUTIC PRINCIPLES

#### Treatment of Infants with SCID

- Always consider an infant with putative SCID as a medical emergency.
- Treat any infections promptly and aggressively.
- Take into account the high frequency of *Pneumocystis jirovecii* pneumonia (PJP). Take appropriate measures to evaluate this possibility (chest X-ray, bronchoalveolar lavage). If PJP is suspected or proven, use trimethoprim-sulfamethoxazole (20 mg/kg/d IV).
- If growth failure is present, start parenteral nutrition.
- Start prophylaxis of PJP with trimethoprim-sulfamethoxazole (5 mg/kg/d).
- Start prophylaxis of fungal infections with fluconazole (5 mg/kg/d).
- Give intravenous immunoglobulins regularly (400 mg/kg/21 days).
- Isolate the infant in a protected environment (laminar flow unit).
- Always irradiate blood products, if transfusions are necessary.
- Avoid administration of live-attenuated vaccines.
- Immediately plan for hematopoietic cell transplantation once the diagnosis of SCID has been established.

and nutritional support may help improve the health status of SCID infants while waiting for HSCT. Blood products need to be irradiated because alloreactive T cells contained in the transfusion would invariably cause rapidly fatal GvHD.

Alternative therapeutic approaches are available in selected cases. Patients affected with ADA deficiency who do not have an HLA-identical donor may be treated with weekly intramuscular injections of polyethylene glycol-conjugated ADA (PEG-ADA).<sup>110</sup>

Successful immune reconstitution has been achieved after gene therapy in 17 of 20 infants with X-linked SCID,<sup>111,112</sup> however, 5 of these 20 patients have developed leukemic proliferation due to insertional mutagenesis.<sup>113,114</sup> New trials with self-inactivating vectors are currently under way. In contrast, no case of leukemia has been observed in approximately 40 patients who have received gene therapy for ADA deficiency at multiple centers.<sup>115-117</sup>

## DiGeorge Syndrome

DiGeorge syndrome (DGS) is characterized by thymic hypoplasia, hypoparathyroidism with consequent hypocalcemia, congenital heart disease (especially interrupted aortic arch type B or truncus arteriosus) and facial dysmorphism (micrognathia, hypertelorism, antimongoloid slant of the eyes, and ear malformations) (Figure 9-3).<sup>118</sup> Feeding problems, microcephaly, speech delay and neurobehavioral problems (including bipolar disorders, autistic spectrum disorders and schizophrenia) are frequently observed.<sup>118</sup> The majority of patients have a partial monosomy of the 22q11 region of chromosome 22. Most patients have residual thymus and a milder immunodeficiency (partial DGS),<sup>118</sup> whereas approximately 1% of the patients



**Figure 9-3** Facial dysmorphic features in an infant with DiGeorge syndrome. Note hypertelorism, enlarged nasal root, anteroverted nostrils, low-set ears and micrognathia.

show complete absence of the thymus and extreme T cell lymphopenia (complete DGS).<sup>119</sup> In some cases, patients with complete DGS may develop a variable number of oligoclonal, activated and functionally anergic T lymphocytes. This phenotype is also referred to as ‘complete atypical DGS’ and may clinically manifest with skin erythroderma and lymphadenopathy, resembling OS.<sup>119</sup> DGS patients with low TRECs at birth may be more prone to viral infections.<sup>120</sup>

Heart defects should be treated aggressively. Hypocalcemia requires supplementation with calcium and vitamin D. If a significant immune defect is present, prophylaxis of *P. jirovecii* pneumonia with trimethoprim-sulfamethoxazole is indicated. Live attenuated vaccines can be safely administered to patients with partial DGS who have good cellular immunity; however, these vaccines are contraindicated in patients with complete DGS. Thymic transplantation is the treatment of choice for patients with complete (typical or atypical) DGS, and results in good (75%) long-term survival and immune reconstitution.<sup>119</sup> Unmanipulated bone marrow transplantation from HLA-identical donors can also lead to immune reconstitution in patients with complete DGS, through a mechanism that involves peripheral expansion of T lymphocytes contained in the graft.<sup>121</sup>

## Syndromes with Significant T Cell Deficiency

### IMMUNO-OSSEOUS SYNDROMES

#### *Cartilage Hair Hypoplasia*

Cartilage hair hypoplasia (CHH) is an autosomal recessive disease characterized by short-limbed dwarfism, light-colored hypoplastic hair and a variable degree of immunodeficiency, associated with an increased occurrence of bone marrow dysplasia, malignancies and Hirschsprung’s disease. The disease is caused by mutations of the gene encoding for the untranslated RNA component of the ribonuclease mitochondrial RNA processing (*RMRP*) complex.<sup>122,123</sup>

The majority of CHH patients have a limited susceptibility to bacterial and viral infections; however, some may present with severe infections early in life and show an immunologic phenotype of SCID, OS or selective CD8<sup>+</sup> lymphocytopenia,<sup>124,125</sup> which may require HSCT.

#### *Schimke Syndrome*

Schimke syndrome is an autosomal recessive disease characterized by dwarfism with progressive renal failure, facial dysmorphisms, lentigines, immunodeficiency and increased occurrence of bone marrow failure and of early-onset atherosclerosis.<sup>126</sup> The syndrome is caused by mutations of the *SMARCAL1* gene that encodes for a chromatin remodeling protein.<sup>126</sup> T cell lymphopenia is common and may occasionally be severe enough to cause SCID. Recurrent bacterial, viral or fungal infections are seen in almost half of the patients.

### COMBINED IMMUNODEFICIENCY WITH MULTIPLE INTESTINAL ATRESIAS

This autosomal recessive disease is caused by mutations of the tetratricopeptide repeat domain 7A (*TTC7A*) gene,<sup>127</sup> resulting in increased Ras homolog family member A (RHOA) signaling and disruption of intestinal epithelial apicobasal polarity.<sup>128</sup>

Numerical and functional defects of T and B lymphocytes and abnormalities of thymic architecture are present.<sup>129</sup>

### IMMUNODEFICIENCY SYNDROMES WITH DEFECTIVE DNA REPAIR

*Ataxia-telangiectasia* (AT) is an autosomal recessive disorder characterized by telangiectasia, progressive ataxia, recurrent respiratory tract infections and increased susceptibility to tumors.<sup>130</sup> The disease is caused by mutations of the *ATM* gene, which encodes for a large protein that participates in the repair of DNA breakage and controls cell cycle and cellular apoptosis.<sup>131</sup>

*Nijmegen breakage syndrome* (NBS) is another cellular radiosensitivity syndrome, characterized by microcephaly, growth retardation, bird-like facies and increased susceptibility to infections and tumors. The disease is caused by mutations of the *NBS1* gene, which encodes for nibrin.<sup>132</sup>

A subgroup of patients with an *AT-like disorder* have been identified in whom the defect was in the *hMRE11* gene, which encodes for another component of the DNA repair machinery that associates with nibrin.<sup>133</sup>

DNA ligase IV (LIG4) is an enzyme involved in nonhomologous DNA end-joining and V(D)J recombination. Deficiency of LIG4 is characterized by microcephaly, growth abnormalities, increased susceptibility to malignancies and pancytopenia.<sup>134</sup> Some patients may present with T<sup>-</sup> B<sup>-</sup> SCID or OS.<sup>19,34</sup>

Patients with AT have increased serum levels of alpha-fetoprotein (AFP), and development of reciprocal chromosomal translocations (mostly involving chromosomes 7 and 14) in a fraction of T lymphocytes is common. Laboratory investigations in patients with AT, AT-like disease or NBS show progressive reduction of the T cell number (particularly the CD4<sup>+</sup> subset) with impaired in vitro proliferative response to mitogens. Low TREC levels at birth may be seen in patients with AT,<sup>135</sup> therefore this condition must be included in the differential diagnosis of disorders that may be identified through newborn screening for SCID.

At present, there is no definitive cure for AT and NBS. Use of prophylactic antibiotics, chest physiotherapy and administration of intravenous immunoglobulins may decrease the risk of infections, but the prognosis remains poor, and infections and tumors are the main causes of death.<sup>130</sup> Exposure to ionizing radiation should be avoided, if possible.

### Wiskott-Aldrich Syndrome

Wiskott-Aldrich syndrome (WAS) is an X-linked disorder characterized by eczema, congenital thrombocytopenia with small-sized platelets, and immune deficiency. The *WAS* gene is located on the X chromosome and encodes for a protein involved in cytoskeleton reorganization in hematopoietic cells.<sup>136</sup> Most patients with typical WAS have mutations that impair expression and/or function of the WAS protein (WASP). However, some missense mutations are associated with a milder phenotype (isolated X-linked thrombocytopenia, XLT) (Figure 9-4).<sup>137</sup>

The immune deficiency of WAS may manifest as recurrent bacterial and viral infections, autoimmune manifestations and increased occurrence of tumors (leukemia, lymphoma). Immunologic laboratory abnormalities include lymphopenia (particularly among CD8<sup>+</sup> lymphocytes), impaired in vitro proliferation to immobilized anti-CD3, reduced serum IgM with





**Figure 9-4** Severe vasculitis and petechiae in a child with Wiskott-Aldrich syndrome.

increased levels of IgA and IgE, and inability to mount effective antibody responses, especially to T-independent antigens.<sup>136</sup> Analysis of intracellular WASP expression by flow cytometry may assist in the diagnosis; absence of the protein is most often associated with a severe clinical phenotype, whereas XLT patients tend to show residual protein expression that is usually associated with missense mutations in exons 1 and 2 of the gene.<sup>137</sup> Somatic reversion, leading to WASP expression in a proportion of cells (mostly in T lymphocytes), has been observed in several patients, but its implications on the evolution of the clinical phenotype are unclear.<sup>138</sup>

The mainstay of treatment of WAS is HSCT, but promising results have been recently reported with gene therapy using a lentiviral vector (see Chapter 16). Administration of intravenous immunoglobulins, regular antibiotic prophylaxis, topical steroids to control eczema, and use of vigorous immune suppression for autoimmunity are the hallmarks of conservative treatment. Splenectomy may be indicated in case of severe and refractory thrombocytopenia; however, it carries the risk of overwhelming sepsis.

### Hyper-IgM Syndromes due to CD40 Ligand (CD40L) or to CD40 Deficiency

CD40 ligand (CD40L, CD154) is a cell surface molecule predominantly expressed by activated CD4<sup>+</sup> T lymphocytes. Interaction of CD40L with its counter-receptor CD40 (expressed by B and dendritic cells, macrophages, endothelial cells and some

epithelial cells) is essential for germinal center formation, terminal differentiation of B lymphocytes and effective defense against intracellular pathogens. Mutations in the *CD40LG* (*TNFSF5*) gene, mapping at Xq26, result in X-linked hyper-IgM syndrome (HIGM1), characterized by an increased occurrence of bacterial and opportunistic infections, chronic diarrhea (often sustained by *Cryptosporidium*), liver/biliary tract disease and susceptibility to liver and gut tumors.<sup>139,140</sup>

Presentation early in life with opportunistic infections (PJP) requires differential diagnosis with SCID and other forms of severe T cell defects. The typical immunoglobulin profile (undetectable or very low serum IgG and IgA, with normal to increased IgM) may also be observed in common variable immunodeficiency or in autosomal recessive hyper-IgM caused by defects in the *AID*, *UNG* or *CD40* genes. Neutropenia is a common finding. The diagnosis of HIGM1 is made based on the demonstration of defective expression of CD40L (but not of other activation markers) on the surface of T cells following *in vitro* activation, and is eventually confirmed by mutation analysis.<sup>139</sup>

Treatment is based on regular use of intravenous immunoglobulins, prophylactic trimethoprim-sulfamethoxazole and use of sterile/filtered water to prevent *Cryptosporidium* infection. Monitoring of liver/biliary tract morphology and function by ultrasound scanning, measurement of appropriate laboratory parameters of liver and biliary tract function, and, when indicated, liver biopsy are also advised. Severe neutropenia may be treated with recombinant granulocyte colony-stimulating factor (G-CSF). In spite of these measures, the long-term prognosis is poor because of severe infections and liver disease. The only curative approach is HSCT, and better results are achieved when transplantation is performed prior to development of lung problems or *Cryptosporidium* infection.<sup>141</sup>

### Conclusions

Irrespective of the specific definitive diagnosis, all forms of T cell immunodeficiencies are characterized by significant morbidity and some of them also by high early-onset mortality rates, emphasizing the critical role played by T lymphocytes in ensuring effective immune defense mechanisms and in maintaining homeostasis. Consequently, it is a primary physician's responsibility to perform accurate clinical and laboratory evaluation of patients with a putative T cell immunodeficiency. Whereas clinical history and physical examination may disclose the diagnosis in some forms of T cell immunodeficiency (e.g. WAS, AT and CHH), laboratory evaluation is most often required to provide a definitive diagnosis. In spite of the heterogeneity of this group of disorders, simple laboratory assays (total lymphocyte count and subsets distribution, *in vitro* proliferative responses) are usually sufficient to confirm the suspicion. It is noteworthy that some forms of T cell immunodeficiencies (SCID in particular) represent true medical emergencies and warrant prompt and accurate evaluation and treatment by HSCT. Based on recent experience, it is likely that gene therapy may be successfully applied in a broader group of disorders in the near future.

### Helpful Websites

Online Mendelian Inheritance in Man (OMIM); website ([www.ncbi.nlm.nih.gov/omim/](http://www.ncbi.nlm.nih.gov/omim/))



European Society for Immune Deficiencies (ESID); website ([www.esid.org/](http://www.esid.org/))

Jeffrey Modell Foundation; website ([www.jmfworld.com/](http://www.jmfworld.com/))

Immune Deficiency Foundation; website ([www.primaryimmune.org](http://www.primaryimmune.org))

Primary Immune Deficiency Treatment Consortium (PIDTC); website ([www.rarediseasesnetwork.org/pidtc/index.htm](http://www.rarediseasesnetwork.org/pidtc/index.htm))

United States Immunodeficiency Network (USIDNET); website ([usidnet.org](http://usidnet.org))

The complete reference list can be found on the companion Expert Consult website at <http://www.expertconsult.inkling.com>.

## KEY REFERENCES

1. Fischer A. Severe combined immunodeficiencies (SCID). *Clin Exp Immunol* 2000;122:143–9.
22. Felgentreff K, Perez-Becker R, Speckmann C, Schwarz K, Kalwak K, Markelj G, et al. Clinical and immunological manifestations of patients with atypical severe combined immunodeficiency. *Clin Immunol* 2011;141:73–82.
102. Shearer WT, Dunn E, Notarangelo LD, Dvorak CC, Puck JM, Logan BR, et al. Establishing diagnostic criteria for severe combined immunodeficiency disease (SCID), leaky SCID, and Omenn syndrome: the Primary Immune Deficiency Treatment Consortium experience. *J Allergy Clin Immunol* 2014;133:1092–8.
103. Buckley RH, Schiff RI, Schiff SE, Markert ML, Williams LW, Harville TO, et al. Human severe combined immunodeficiency: genetic, phenotypic, and functional diversity in one hundred eight infants. *J Pediatr* 1997;130:378–87.
108. Kwan A, Abraham RS, Currier R, Brower A, Andruszewski K, Abbott JK, et al. Newborn screening for severe combined immunodeficiency in 11 screening programs in the United States. *J Am Med Assoc* 2014;312:729–38.
111. Hacein-Bey-Abina S, Le Deist F, Carlier F, Bouneaud C, Hue C, de Villartay JP, et al. Sustained correction of X-linked severe combined immunodeficiency by ex vivo gene therapy. *N Engl J Med* 2002;346:1185–93.
115. Aiuti A, Cattaneo F, Galimberti S, Benninghoff U, Cassani B, Callegaro L, et al. Gene therapy for immunodeficiency due to adenosine deaminase deficiency. *N Engl J Med* 2009;360:447–58.
118. Kobrynski LJ, Sullivan KE. Velocardiofacial syndrome, DiGeorge syndrome: the chromosome 22q11.2 deletion syndromes. *Lancet* 2007;370:1443–52.
130. Gennery AR, Cant AC, Jeggo PA. Immunodeficiency associated with DNA repair defect. *Clin Exp Immunol* 2000;121:1–7.
136. Massaad MJ, Ramesh N, Geha RS. Wiskott-Aldrich syndrome: a comprehensive review. *Ann N Y Acad Sci* 2013;1285:26–43.

## REFERENCES

- Fischer A. Severe combined immunodeficiencies (SCID). *Clin Exp Immunol* 2000;122:143–9.
- Cassani B, Mirolo M, Cattaneo F, Benninghoff U, Hershfield M, Carlucci F, et al. Altered intracellular and extracellular signaling leads to impaired T cell functions in ADA-SCID patients. *Blood* 2008;111:4209–19.
- Ozsahin H, Arredondo-Vega FX, Santisteban I, Fuhrer H, Tuchschnid P, Jochum W, et al. Adenosine deaminase deficiency in adults. *Blood* 1997;89:2849–55.
- de Vaal OM, Seynhaeve V. Reticular dysgenesis. *Lancet* 1959;ii:1123–4.
- Pannicke U, Honig M, Hess I, Friesen C, Holzmann K, Rump EM, et al. Reticular dysgenesis (aleukocytosis) is caused by mutations in the gene encoding mitochondrial adenylate kinase 2. *Nat Genet* 2009;41:101–5.
- Lagresle-Peyrou C, Six EM, Picard C, Rieux-Laucat F, Michel V, Ditadi A, et al. Human adenylate kinase 2 deficiency causes a profound hematopoietic defect associated with sensorineural deafness. *Nat Genet* 2009;41:106–11.
- Noguchi M, Yi H, Rosenblatt HM, Filipovich AH, Adelstein S, Modi WS, et al. Interleukin-2 receptor gamma chain mutation results in X-linked severe combined immunodeficiency in humans. *Cell* 1993;73:147–57.
- Leonard WJ, Noguchi M, Russell SM, McBride OW. The molecular basis of X-linked severe combined immunodeficiency: the role of the interleukin-2 receptor gamma chain as a common gamma chain, gamma c. *Immunol Rev* 1994;138:61–86.
- O'Shea JJ, Notarangelo LD, Johnston JA, Candotti F. Advances in the understanding of cytokine signal transduction: the role of Jaks and STATs in immunoregulation and the pathogenesis of immunodeficiency. *J Clin Immunol* 1997;17:431–47.
- Macchi P, Villa A, Giliani S, Sacco MG, Frattini A, Porta F, et al. Mutations of Jak-3 gene in patients with autosomal severe combined immune deficiency (SCID). *Nature* 1995;377:65–8.
- Russell SM, Tayebi N, Nakajima H, Riedy MC, Roberts JL, Aman MJ, et al. Mutation of Jak3 in a patient with SCID: essential role of Jak3 in lymphoid development. *Science* 1995;270:797–800.
- Puel A, Ziegler S, Buckley RH, Leonard WJ. Defective IL7R expression in TB+ NK+ severe combined immunodeficiency. *Nat Genet* 1998;20:394–7.
- Sekiguchi J, Frank K. V(D)J recombination. *Curr Biol* 1999;22:835.
- Oettinger MA, Schatz DG, Gorka C, Baltimore D. RAG-1 and RAG-2, adjacent genes that synergistically activate V(D)J recombination. *Science* 1990;248:1517–23.
- Schwarz K, Gauss GH, Ludwig L, Pannicke U, Li Z, Lindner D, et al. RAG mutations in human B cell-negative SCID. *Science* 1996;274:97–9.
- Moshous D, Callebaut I, de Chasseval R, Corneo B, Cavazzana-Calvo M, Le Deist F, et al. Artemis, a novel DNA double-strand break repair/V(D)J recombination protein, is mutated in human severe combined immune deficiency. *Cell* 2001;105:177–86.
- van der Burg M, Ijspeert H, Verkaik NS, Turul T, Wiegant WW, Morotomi-Yano K, et al. A DNA-PKcs mutation in a radiosensitive T-B-SCID patient inhibits Artemis activation and nonhomologous end-joining. *J Clin Invest* 2009;119:91–8.
- Buck D, Moshous D, de Chasseval R, Ma Y, le Deist F, Cavazzana-Calvo M, et al. Severe combined immunodeficiency and microcephaly in siblings with hypomorphic mutations in DNA ligase IV. *Eur J Immunol* 2006;36:224–35.
- van der Burg M, van Veelen LR, Verkaik NS, Wiegant WW, Hartwig NG, Barendregt BH, et al. A new type of radiosensitive T-B-NK+ severe combined immunodeficiency caused by a LIG4 mutation. *J Clin Invest* 2006;116:137–45.
- Buck D, Malivert L, de Chasseval R, Barraud A, Fondaneche MC, Sanal O, et al. Cernunnos, a novel nonhomologous end-joining factor, is mutated in human immunodeficiency with microcephaly. *Cell* 2006;124:287–99.
- Schuetz C, Huck K, Gudowius S, Megahed M, Feyen O, Hubner B, et al. An immunodeficiency disease with RAG mutations and granulomas. *N Engl J Med* 2008;358:2030–8.
- Felgentreff K, Perez-Becker R, Speckmann C, Schwarz K, Kalwak K, Markelj G, et al. Clinical and immunological manifestations of patients with atypical severe combined immunodeficiency. *Clin Immunol* 2011;141:73–82.
- Dadi HK, Simon AJ, Roifman CM. Effect of CD3delta deficiency on maturation of alpha/beta and gamma/delta T cell lineages in severe combined immunodeficiency. *N Engl J Med* 2003;349:1821–8.
- de Saint Basile G, Geissmann F, Flori E, Uring-Lambert B, Soudais C, Cavazzana-Calvo M, et al. Severe combined immunodeficiency caused by deficiency in either the delta or the epsilon subunit of CD3. *J Clin Invest* 2004;114:1512–17.
- Rieux-Laucat F, Hivroz C, Lim A, Mateo V, Peller I, Selz F, et al. Inherited and somatic CD3zeta mutations in a patient with T cell deficiency. *N Engl J Med* 2006;354:1913–21.
- Arnaiz-Villena A, Timon M, Corell A, Perez-Aciego P, Martin-Villa JM, Regueiro JR. Primary immunodeficiency caused by mutations in the gene encoding the CD3-gamma subunit of the T lymphocyte receptor. *N Engl J Med* 1992;327:529–33.
- Recio MJ, Moreno-Pelayo MA, Kilic SS, Guardo AC, Sanal O, Allende LM, et al. Differential biological role of CD3 chains revealed by human immunodeficiencies. *J Immunol* 2007;178:2556–64.
- Kung C, Pingel JT, Heikinheimo M, Klemola T, Varkila K, Yoo LI, et al. Mutations in the tyrosine phosphatase CD45 gene in a child with severe combined immunodeficiency disease. *Nat Med* 2000;6:343–5.
- Tchilian EZ, Wallace DL, Wells RS, Flower DR, Morgan G, Beverley PC. A deletion in the gene encoding the CD45 antigen in a patient with SCID. *J Immunol* 2001;166:1308–13.
- Omenn GS. Familial reticuloendotheliosis with eosinophilia. *N Engl J Med* 1965;273:427–32.
- Villa A, Santagata S, Bozzi F, Giliani S, Frattini A, Imberti L, et al. Partial V(D)J recombination activity leads to Omenn syndrome. *Cell* 1998;93:885–96.
- Ege M, Ma Y, Manfras B, Kalwak K, Lu H, Lieber MR, et al. Omenn syndrome due to ARTEMIS mutations. *Blood* 2005;105:4179–86.
- Giliani S, Bonfim C, de Saint Basile G, Lanzi G, Brousse N, Koliski A, et al. Omenn syndrome in an infant with IL7RA gene mutation. *J Pediatr* 2006;148:272–4.
- Grunebaum E, Bates A, Roifman CM. Omenn syndrome is associated with mutations in DNA ligase IV. *J Allergy Clin Immunol* 2008;122:1219–20.
- Roifman CM, Gu Y, Cohen A. Mutations in the RNA component of RNase mitochondrial RNA processing might cause Omenn syndrome. *J Allergy Clin Immunol* 2006;117:897–903.
- Wada T, Yasui M, Toma T, Nakayama Y, Nishida M, Shimizu M, et al. Detection of T lymphocytes with a second-site mutation in skin lesions of atypical X-linked severe combined immunodeficiency mimicking Omenn syndrome. *Blood* 2008;112:1872–5.
- Roifman CM, Zhang J, Atkinson A, Grunebaum E, Mandel K. Adenosine deaminase deficiency can present with features of Omenn syndrome. *J Allergy Clin Immunol* 2008;121:1056–8.
- Turul T, Tezcan I, Artac H, de Bruin-Versteeg S, Barendregt BH, Reisli I, et al. Clinical heterogeneity can hamper the diagnosis of patients with ZAP70 deficiency. *Eur J Pediatr* 2009;168:87–93.
- Henderson LA, Frugoni F, Hopkins G, Al-Herz W, Weinacht K, Comeau AM, et al. First reported case of Omenn syndrome in a patient with reticular dysgenesis. *J Allergy Clin Immunol* 2013;131:1227–30.
- Cavadini P, Vermi W, Facchetti F, Fontana S, Nagafuchi S, Mazzolari E, et al. AIRE deficiency in thymus of 2 patients with Omenn syndrome. *J Clin Invest* 2005;115:728–32.
- de Villartay JP, Lim A, Al-Mousa H, Dupont S, Dechanet-Merville J, Coumou-Gatbois E, et al. A novel immunodeficiency associated with hypomorphic RAG1 mutations and CMV infection. *J Clin Invest* 2005;115:3291–9.
- Ehl S, Schwarz K, Enders A, Duffner U, Pannicke U, Kuhr J, et al. A variant of SCID with specific immune responses and predominance of gamma delta T cells. *J Clin Invest* 2005;115:3140–8.
- De Ravin SS, Cowen EW, Zarembek KA, Whiting-Theobald NL, Kuhns DB, Sandler NG, et al. Hypomorphic Rag mutations can cause destructive midline granulomatous disease. *Blood* 2010;116:1263–71.
- Lee YN, Frugoni F, Dobbs K, Walter JE, Giliani S, Gennery AR, et al. A systematic analysis of recombination activity and genotype-phenotype correlation in human recombination-activating gene 1 deficiency. *J Allergy Clin Immunol* 2014;133:1099–108.
- Ijspeert H, Driessen GJ, Moorhouse MJ, Hartwig NG, Wolska-Kusnierz B, Kalwak K, et al. Similar recombination-activating gene (RAG) mutations result in similar immunobiological effects but in different clinical phenotypes. *J Allergy Clin Immunol* 2014;133:1124–33.
- Markert ML, Finkel BD, McLaughlin TM, Watson TJ, Collard HR, McMahon CP, et al. Mutations in purine nucleoside phosphorylase deficiency. *Hum Mutat* 1997;9:118–21.
- Morgan NV, Goddard S, Cardno TS, McDonald D, Rahman F, Barge D, et al. Mutation in

- the TCR $\alpha$  subunit constant gene (TRAC) leads to a human immunodeficiency disorder characterized by a lack of TCR $\alpha\beta^+$  T cells. *J Clin Invest* 2011;121:695–702.
48. van Leeuwen JEM, Samelson LE. T cell antigen-receptor signal transduction. *Curr Opin Immunol* 1999;11:242–8.
  49. Chan AC, Kadlecik TA, Elder ME, Filipovich AH, Kuo WL, Iwashima M, et al. ZAP-70 deficiency in an autosomal recessive form of severe combined immunodeficiency. *Science* 1994;264:1599–601.
  50. Arpaia E, Shahar M, Dadi H, Cohen A, Roifman CM. Defective T cell receptor signaling and CD8+ thymic selection in humans lacking Zap-70 kinase. *Cell* 1994;76:947–58.
  51. Elder ME, Lin D, Clever J, Chan AC, Hope TJ, Weiss A, et al. Human severe combined immunodeficiency due to a defect in ZAP-70, a T cell tyrosine kinase. *Science* 1994;264:1596–9.
  52. Hauck F, Randriamampita C, Martin E, Gerart S, Lambert N, Lim A, et al. Primary T-cell immunodeficiency with immunodysregulation caused by autosomal recessive LCK deficiency. *J Allergy Clin Immunol* 2012;130:1144–52.
  53. Crequer A, Troeger A, Patin E, Ma CS, Picard C, Pedergnana V, et al. Human RHOH deficiency causes T cell defects and susceptibility to EV-HPV infections. *J Clin Invest* 2012;122:3239–47.
  54. Nehme NT, Pachlopnik Schmid J, Debeurme F, Lim A, Nitschke P, Rieux-Laucat F, et al. MST1 mutations in autosomal recessive primary immunodeficiency characterized by defective naive T-cell survival. *Blood* 2012;119:3458–68.
  55. Abdollahpour H, Appaswamy G, Kotlarz D, Diestelhorst J, Beier R, Schaffer AA, et al. The phenotype of human STK4 deficiency. *Blood* 2012;119:3450–7.
  56. Crequer A, Picard C, Patin E, D'Amico A, Abhyankar A, Munzer M, et al. Inherited MST1 deficiency underlies susceptibility to EV-HPV infections. *PLoS ONE* 2012;7:e44010.
  57. Huck K, Feyen O, Niehues T, Ruschendorf F, Hubner N, Laws HJ, et al. Girls homozygous for an IL-2-inducible T cell kinase mutation that leads to protein deficiency develop fatal EBV-associated lymphoproliferation. *J Clin Invest* 2009;119:1350–8.
  58. Stepsensky P, Weintraub M, Yanir A, Revel-Vilk S, Krux F, Huck K, et al. IL-2-inducible T-cell kinase deficiency: clinical presentation and therapeutic approach. *Haematologica* 2011;96:472–6.
  59. Linka RM, Risse SL, Bienemann K, Werner M, Linka Y, Krux F, et al. Loss-of-function mutations within the IL-2 inducible kinase ITK in patients with EBV-associated lymphoproliferative diseases. *Leukemia* 2012;26:963–71.
  60. Mansouri D, Mahdavian SA, Khalilzadeh S, Mohajerani SA, Hasanzad M, Sadr S, et al. IL-2-inducible T-cell kinase deficiency with pulmonary manifestations due to disseminated Epstein-Barr virus infection. *Int Arch Allergy Immunol* 2012;158:418–22.
  61. Zhang Q, Davis JC, Lamborn IT, Freeman AF, Jing H, Favreau AJ, et al. Combined immunodeficiency associated with DOCK8 mutations. *N Engl J Med* 2009;361:2046–55.
  62. Engelhardt KR, McGhee S, Winkler S, Sassi A, Woellner C, Lopez-Herrera G, et al. Large deletions and point mutations involving the dedicator of cytokinesis 8 (DOCK8) in the autosomal-recessive form of hyper-IgE syndrome. *J Allergy Clin Immunol* 2009;124:1289–302.
  63. Randall KL, Chan SS, Ma CS, Fung I, Mei Y, Yabas M, et al. DOCK8 deficiency impairs CD8 T cell survival and function in humans and mice. *J Exp Med* 2011;208:2305–20.
  64. Crawford G, Enders A, Gileadi U, Stankovic S, Zhang Q, Lambe T, et al. DOCK8 is critical for the survival and function of NKT cells. *Blood* 2013;122:2052–61.
  65. Mizesko MC, Banerjee PP, Monaco-Shawver L, Mace EM, Bernal WE, Sawalle-Belohradsky J, et al. Defective actin accumulation impairs human natural killer cell function in patients with dedicator of cytokinesis 8 deficiency. *J Allergy Clin Immunol* 2013;131:840–8.
  66. Keles S, Jabara HH, Reisli I, McDonald DR, Barlan I, Hanna-Wakim R, et al. Plasmacytoid dendritic cell depletion in DOCK8 deficiency: rescue of severe herpetic infections with IFN- $\alpha$  2b therapy. *J Allergy Clin Immunol* 2014;133:1753–5.
  67. Randall KL, Lambe T, Johnson AL, Treanor B, Kucharska E, Domaschenz H, et al. Dock8 mutations cripple B cell immunological synapses, germinal centers and long-lived antibody production. *Nat Immunol* 2009;10:1283–91.
  68. Jabara HH, McDonald DR, Janssen E, Massaad MJ, Ramesh N, Borzutzky A, et al. DOCK8 functions as an adaptor that links TLR-MyD88 signaling to B cell activation. *Nat Immunol* 2012;13:612–20.
  69. Barlogis V, Galambrun C, Chambost H, Lamoreux-Toth S, Petit P, Stephan JL, et al. Successful allogeneic hematopoietic stem cell transplantation for DOCK8 deficiency. *J Allergy Clin Immunol* 2011;128:420–2.
  70. Frank J, Pignata C, Panteleyev AA, Prowse DM, Baden H, Weiner L, et al. Exposing the human nude phenotype. *Nature* 1999;398:473–4.
  71. Markert ML, Marques JG, Neven B, Devlin BH, McCarthy EA, Chinn IK, et al. First use of thymus transplantation therapy for FOXP1 deficiency (nude/SCID): a report of 2 cases. *Blood* 2011;117:688–96.
  72. Shioh LR, Roadcap DW, Paris K, Watson SR, GrigoroVA IL, Lebet T, et al. The actin regulator coronin 1A is mutant in a thymic egress-deficient mouse strain and in a patient with severe combined immunodeficiency. *Nat Immunol* 2008;9:1307–15.
  73. Moshous D, Martin E, Carpentier W, Lim A, Callebaut I, Canioni D, et al. Whole-exome sequencing identifies Coronin-1A deficiency in 3 siblings with immunodeficiency and EBV-associated B-cell lymphoproliferation. *J Allergy Clin Immunol* 2013;131:1594–603.
  74. Steimle V, Otten LA, Zufferey M, Mach B. Complementation cloning of an MHC class II transactivator mutated in hereditary MHC class II deficiency (or bare lymphocyte syndrome). *Cell* 1993;75:135–46.
  75. Masternak K, Barras E, Zufferey M, Conrad B, Corthais G, Aebersold R, et al. A gene encoding a novel RFX-associated transactivator is mutated in the majority of MHC class II deficiency patients. *Nat Genet* 1998;20:273–7.
  76. Steimle V, Durand B, Barras E, Zufferey M, Hadam MR, Mach B, et al. A novel DNA-binding regulatory factor is mutated in primary MHC class II deficiency (bare lymphocyte syndrome). *Genes Dev* 1995;9:1021–32.
  77. Durand B, Sperisen P, Emery P, Barras E, Zufferey M, Mach B, et al. RFXAP, a novel subunit of the RFX DNA binding complex is mutated in MHC class II deficiency. *EMBO J* 1997;16:1045–55.
  78. Gadola SD, Moins-Teisserenc HT, Trowsdale J, Gross WL, Cerundolo V. TAP deficiency syndrome. *Clin Exp Immunol* 2000;121:173–8.
  79. de la Salle H, Zimmer J, Fricker D, Angenieux C, Cazenave JP, Okubo M, et al. HLA class I deficiencies due to mutations in subunit 1 of the peptide transporter TAP1. *J Clin Invest* 1999;103:9–13.
  80. de la Salle H, Hanau D, Fricker D, Urlacher A, Kelly A, Salamero J, et al. Homozygous human TAP peptide transporter mutation in HLA class I deficiency. *Science* 1994;265:237–41.
  81. Yabe T, Kawamura S, Sato M, Kashiwase K, Tanaka H, Ishikawa Y, et al. A subject with a novel type I bare lymphocyte syndrome has tapasin deficiency due to deletion of 4 exons by Alu-mediated recombination. *Blood* 2002;100:1496–8.
  82. Feske S, Gwack Y, Prakriya M, Srikanth S, Puppel SH, Tanasa B, et al. A mutation in Orail causes immune deficiency by abrogating CRAC channel function. *Nature* 2006;441:179–85.
  83. Picard C, McCarl CA, Papolos A, Khalil S, Luthy K, Hivroz C, et al. STIM1 mutation associated with a syndrome of immunodeficiency and autoimmunity. *N Engl J Med* 2009;360:1971–80.
  84. Byun M, Abhyankar A, Lelarge V, Plancoulaine S, Palanduz A, Telhan L, et al. Whole-exome sequencing-based discovery of STIM1 deficiency in a child with fatal classic Kaposi sarcoma. *J Exp Med* 2010;207:2307–12.
  85. Li FY, Chaigne-Delalande B, Kanellopoulou C, David JC, Matthews HF, Douek DC, et al. Second messenger role for Mg<sup>2+</sup> revealed by human T-cell immunodeficiency. *Nature* 2011;475:471–6.
  86. Li FY, Chaigne-Delalande B, Su H, Uzel G, Matthews H, Lenardo MJ. XMEN disease: a new primary immunodeficiency affecting Mg<sup>2+</sup> regulation of immunity against Epstein-Barr virus. *Blood* 2014;123:2148–52.
  87. Chaigne-Delalande B, Li FY, O'Connor GM, Lukacs MJ, Jiang P, Zheng L, et al. Mg<sup>2+</sup> regulates cytotoxic functions of NK and CD8 T cells in chronic EBV infection through NKG2D. *Science* 2013;341:186–91.
  88. Caudy AA, Reddy ST, Chatila T, Atkinson JP, Verbsky JW. CD25 deficiency causes an immune dysregulation, polyendocrinopathy, enteropathy, X-linked-like syndrome, and defective IL-10 expression from CD4 lymphocytes. *J Allergy Clin Immunol* 2007;119:482–7.
  89. Sharfe N, Dadi HK, Shahar M, Roifman CM. Human immune disorder arising from mutation of the chain of the interleukin-2 receptor. *Proc Natl Acad Sci U S A* 1997;94:3168–71.
  90. Nadeau K, Hwa V, Rosenfeld RG. STAT5b deficiency: an unsuspected cause of growth failure, immunodeficiency, and severe pulmonary disease. *J Pediatr* 2011;158:701–8.
  91. Kotlarz D, Zięta N, Uzel G, Weidemann T, Braun CJ, Diestelhorst J, et al. Loss-of-function mutations in the IL-21 receptor gene cause a primary immunodeficiency syndrome. *J Exp Med* 2013;210:433–43.
  92. Salzer E, Daschkey S, Choo S, Gombert M, Santos-Valente E, Ginzel S, et al. Combined

- immunodeficiency with life-threatening EBV-associated lymphoproliferative disorder in patients lacking functional CD27. *Haematologica* 2013;98:473–8.
93. van Montfrans JM, Hoepelman AI, Otto S, van Gijn M, van de Corput L, de Weger RA, et al. CD27 deficiency is associated with combined immunodeficiency and persistent symptomatic EBV viremia. *J Allergy Clin Immunol* 2012;129:787–93.
  94. Jabara HH, Ohsumi T, Chou J, Massaad MJ, Benson H, Megarbane A, et al. A homozygous mucosa-associated lymphoid tissue 1 (MALT1) mutation in a family with combined immunodeficiency. *J Allergy Clin Immunol* 2013;132:151–8. Erratum in: *J Allergy Clin Immunol* 2013;132:773.
  95. Stepensky P, Keller B, Buchta M, Kienzler AK, Elpeleg O, Somech R, et al. Deficiency of caspase recruitment domain family, member 11 (CARD11), causes profound combined immunodeficiency in human subjects. *J Allergy Clin Immunol* 2013;131:477–85.
  96. Greil J, Rausch T, Giese T, Bandapalli OR, Daniel V, Bekerdjian-Ding I, et al. Whole-exome sequencing links caspase recruitment domain 11 (CARD11) inactivation to severe combined immunodeficiency. *J Allergy Clin Immunol* 2013;131:1376–83.
  97. Pannicke U, Baumann B, Fuchs S, Henneke P, Rensing-Ehl A, Rizzi M, et al. Deficiency of innate and acquired immunity caused by an IKKB mutation. *N Engl J Med* 2013;369:2504–14.
  98. Lucas CL, Kuehn HS, Zhao F, Niemela JE, Deenick EK, Palendira U, et al. Dominant-activating germline mutations in the gene encoding the PI(3)K catalytic subunit p110 $\delta$  result in T cell senescence and human immunodeficiency. *Nat Immunol* 2014;15:88–97.
  99. Angulo I, Vadas O, Garçon F, Banham-Hall E, Plagnol V, Leathy TR, et al. Phosphoinositide 3-kinase  $\delta$  gene mutation predisposes to respiratory infection and airway damage. *Science* 2013;342:866–71.
  100. Crank MC, Grossman JK, Moir S, Pittaluga S, Buckner CM, Kardava L, et al. Mutations in *PIK3CD* can cause hyper IgM syndrome (HIGM) associated with increased cancer susceptibility. *J Clin Immunol* 2014;34:272–6.
  101. Martin E, Palmic N, Sanquer S, Lenoir C, Hauck F, Mongellaz C, et al. CTP synthase 1 deficiency in humans reveals its central role in lymphocyte proliferation. *Nature* 2014;510:288–92.
  102. Shearer WT, Dunn E, Notarangelo LD, Dvorak CC, Puck JM, Logan BR, et al. Establishing diagnostic criteria for severe combined immunodeficiency disease (SCID), leaky SCID, and Omenn syndrome: the Primary Immune Deficiency Treatment Consortium experience. *J Allergy Clin Immunol* 2014;133:1092–8.
  103. Buckley RH, Schiff RI, Schiff SE, Markert ML, Williams LW, Harville TO, et al. Human severe combined immunodeficiency: genetic, phenotypic, and functional diversity in one hundred eight infants. *J Pediatr* 1997;130:378–87.
  104. Muller SM, Ege M, Pottharst A, Schulz AS, Schwarz K, Friedrich W. Transplacentally acquired maternal T lymphocytes in severe combined immunodeficiency: a study of 121 patients. *Blood* 2001;98:1847–51.
  105. Bollinger ME, Arredondo-Vega FX, Santisteban I, Schwarz K, Hershfield MS, Lederman HM. Hepatic dysfunction as a complication of adenosine deaminase deficiency. *N Engl J Med* 1996;334:1367–71.
  106. Carson DA, Carrera CJ. Immunodeficiency secondary to adenosine deaminase deficiency and purine nucleoside phosphorylation deficiency. *Semin Hematol* 1990;27:260–9.
  107. Bennett CL, Ochs HD. IPEX is a unique X-linked syndrome characterized by immune dysfunction, polyendocrinopathy, enteropathy, and a variety of autoimmune phenomena. *Curr Opin Pediatr* 2001;13:533–8.
  108. Kwan A, Abraham RS, Currier R, Brower A, Andruszewski K, Abbott JK, et al. Newborn screening for severe combined immunodeficiency in 11 screening programs in the United States. *J Am Med Assoc* 2014;312:729–38.
  109. Buckley RH. Molecular defects in human severe combined immunodeficiency and approaches to immune reconstitution. *Annu Rev Immunol* 2004;22:625–55.
  110. Booth C, Hershfield M, Notarangelo L, Buckley R, Hoening M, Mahlaoui N, et al. Management options for adenosine deaminase deficiency; proceedings of the EBMT satellite workshop (Hamburg, March 2006). *Clin Immunol* 2007;123:139–47.
  111. Hacein-Bey-Abina S, Le Deist F, Carlier F, Bouneaud C, Hue C, de Villartay JP, et al. Sustained correction of X-linked severe combined immunodeficiency by ex vivo gene therapy. *N Engl J Med* 2002;346:1185–93.
  112. Gaspar HB, Parsley KL, Howe S, King D, Gilmour KC, Sinclair J, et al. Gene therapy of X-linked severe combined immunodeficiency by use of a pseudotyped gammaretroviral vector. *Lancet* 2004;364:2181–7.
  113. Hacein-Bey-Abina S, Garrigue A, Wang GP, Soulier J, Lim A, Morillon E, et al. Insertional oncogenesis in 4 patients after retrovirus-mediated gene therapy of SCID-X1. *J Clin Invest* 2008;118:3132–42.
  114. Howe SJ, Mansour MR, Schwarzwaelder K, Bartholomae C, Hubank M, Kempinski H, et al. Insertional mutagenesis combined with acquired somatic mutations causes leukemogenesis following gene therapy of SCID-X1 patients. *J Clin Invest* 2008;118:3143–50.
  115. Aiuti A, Cattaneo F, Galimberti S, Benninghoff U, Cassani B, Callegaro L, et al. Gene therapy for immunodeficiency due to adenosine deaminase deficiency. *N Engl J Med* 2009;360:447–58.
  116. Gaspar HB, Cooray S, Gilmour KC, Parsley KL, Zhang F, Adams S, et al. Hematopoietic stem cell gene therapy for adenosine deaminase-deficient severe combined immunodeficiency leads to long-term immunological recovery and metabolic correction. *Sci Transl Med* 2011;3:97ra80.
  117. Candotti F, Shaw KL, Muul L, Carbonaro D, Sokolic R, Choi C, et al. Gene therapy for adenosine deaminase-deficient severe combined immune deficiency: clinical comparison of retroviral vectors and treatment plans. *Blood* 2012;120:3635–46.
  118. Kobrynski LJ, Sullivan KE. Velocardiofacial syndrome, DiGeorge syndrome: the chromosome 22q11.2 deletion syndromes. *Lancet* 2007;370:1443–52.
  119. Lingman Framme J, Borte S, von Döbeln U, Hammarström L, Oskarsdóttir S. Retrospective analysis of TREC based newborn screening results and clinical phenotypes in infants with the 22q11 deletion syndrome. *J Clin Immunol* 2014;34:514–19.
  120. Markert ML, Devlin BH, Alexieff MJ, Li J, McCarthy EA, Gupton SE, et al. Review of 54 patients with complete DiGeorge anomaly enrolled in protocols for thymus transplantation: outcome of 44 consecutive transplants. *Blood* 2007;109:4539–47.
  121. Land MH, Garcia-Lloret MI, Borzy MS, Rao PN, Aziz N, McGhee SA, et al. Long-term results of bone marrow transplantation in complete DiGeorge syndrome. *J Allergy Clin Immunol* 2007;120:908–15.
  122. Ridanpaa M, van Eenennaam H, Pelin K, Chadwick R, Johnson C, Yuan B, et al. Mutations in the RNA component of RNase MRP cause a pleiotropic human disease, cartilage-hair hypoplasia. *Cell* 2001;104:195–203.
  123. Rogler LE, Kosmyna B, Moskowitz D, Bewawee R, Rahimzadeh J, Kutchko K, et al. Small RNAs derived from lncRNA RNase MRP have gene-silencing activity relevant to human cartilage-hair hypoplasia. *Hum Mol Genet* 2014;23:368–82.
  124. Roifman CM, Gu Y, Cohen A. Mutations in the RNA component of RNase mitochondrial RNA processing might cause Omenn syndrome. *J Allergy Clin Immunol* 2006;117:897–903.
  125. Kavadas FD, Giliani S, Gu Y, Mazzolari E, Bates A, Pegolani E, et al. Variability of clinical and laboratory features among patients with ribonuclease mitochondrial RNA processing endoribonuclease gene mutations. *J Allergy Clin Immunol* 2008;122:1178–84.
  126. Boerkoel CF, O'Neill S, Andre JL, Benke PJ, Bogdanovic R, Bulla M, et al. Manifestations and treatment of Schimke immuno-osseous dysplasia: 14 new cases and a review of the literature. *Eur J Pediatr* 2000;159:1–7.
  127. Samuels ME, Majewski J, Alirezaie N, Fernandez I, Casals F, Patey N, et al. Exome sequencing identifies mutations in the gene *TTC7A* in French-Canadian cases with hereditary multiple intestinal atresia. *J Med Genet* 2013;50:324–9.
  128. Bigorgne AE, Farin HF, Lemoine R, Mahaloui N, Lambert N, Gil M, et al. *TTC7A* mutations disrupt intestinal epithelial apical-basal polarity. *J Clin Invest* 2014;124:328–37.
  129. Chen R, Giliani S, Lanzi G, Mias GI, Lonardi S, Dobbs K, et al. Whole-exome sequencing identifies tetratricopeptide repeat domain 7A (*TTC7A*) mutations for combined immunodeficiency with intestinal atresias. *J Allergy Clin Immunol* 2013;132:656–64.
  130. Gennery AR, Cant AC, Jeggo PA. Immunodeficiency associated with DNA repair defect. *Clin Exp Immunol* 2000;121:1–7.
  131. Savitsky K, Bar-Shira A, Gilad S, Rotman G, Ziv Y, Vanagaite L, et al. A single ataxia-telangiectasia gene with a product similar to PI-3 kinase. *Science* 1995;268:1749–53.
  132. Varon R, Vissinga C, Platzer M, Cerosaletti KM, Chrzanowska KH, Saar K, et al. Nibrin, a novel DNA double-strand break repair protein, is mutated in Nijmegen breakage syndrome. *Cell* 1998;93:467–76.
  133. Stewart GS, Maser RS, Stankovic T, Bressan DA, Kaplan MI, Jaspers NG, et al. The DNA double-strand break repair gene hMRE11 is mutated in individuals with an ataxia-telangiectasia-like disorder. *Cell* 1999;99:577–87.



134. O'Driscoll M, Cerosaletti KM, Girard PM, Dai Y, Stumm M, Kysela B, et al. DNA ligase IV mutations identified in patients exhibiting developmental delay and immunodeficiency. *Mol Cell* 2001;8:1175–85.
135. Borte S, von Döbeln U, Fasth A, Wang N, von Döbeln U, Fasth A, et al. Neonatal screening for severe primary immunodeficiency diseases using high-throughput triplex real-time PCR. *Blood* 2012;119:2552–5.
136. Massaad MJ, Ramesh N, Geha RS. Wiskott-Aldrich syndrome: a comprehensive review. *Ann N Y Acad Sci* 2013;1285:26–43.
137. Jin Y, Mazza C, Christie JR, Giliani S, Fiorini M, Mella P, et al. Mutations of the Wiskott-Aldrich Syndrome Protein (WASP): hotspots, effect on transcription, and translation and phenotype/genotype correlation. *Blood* 2004;104:4010–19.
138. Davis BR, Candotti F. Revertant somatic mosaicism in the Wiskott-Aldrich syndrome. *Immunol Res* 2009;44:127–31.
139. Notarangelo LD, Hayward AR. X-linked immunodeficiency with hyper IgM (X-HIM). *Clin Exp Immunol* 2000;120:349–405.
140. Winkelstein JA, Marino MC, Ochs H, Fuleihan R, Scholl PR, Geha R, et al. The X-linked hyper-IgM syndrome: clinical and immunologic features of 79 patients. *Medicine (Baltimore)* 2003;82:373–84.
141. Gennery AR, Khawaja K, Veys P, Bredius RG, Notarangelo LD, Mazzolari E, et al. Treatment of CD40 ligand deficiency by hematopoietic stem cell transplantation: a survey of the European experience 1993–2002. *Blood* 2004;103:1152–7.

# Complement Deficiencies

KATHLEEN E. SULLIVAN

## KEY POINTS

- SLE and neisserial infections are the common complement deficiency phenotypes seen in Allergy Immunology practices.
- CH50 and AH50 assays represent logical initial studies to diagnose many complement deficiencies.
- Management of infection risk and autoimmunity are evolving but are critically important.

The complement system was first identified at the end of the 19th century as a serum activity that ‘complemented’ the action of antibody in the lysis of Gram-negative bacteria. During the next 100 years there was a growing appreciation that complement not only played an important role in host defense against infection but also was important in the generation of inflammation, the clearance of immune complexes and apoptotic cells, and the production of a normal humoral immune response.

## Pathophysiology of Increased Susceptibility to Infection

An increased susceptibility to infection is a prominent clinical expression of most of the complement deficiency diseases. The activation of the complement system by microorganisms results in the generation of cleavage products and macromolecular complexes that possess opsonic activity (C3b), anaphylatoxic activity (C4a, C3a, and C5a), chemotactic activity (C5a) or bactericidal/bacteriolytic activity (C5b, C6, C7, C8 and C9) (Table 10-1). All play a role in the host’s defense against infection. Its protective effects are critical in the generation of the initial inflammatory response to infection, prevention of spread of the infection from the initial site of infection to other areas of the body and clearance of the microorganism from the bloodstream. Furthermore, it appears to play its most important role in the early stages of infection, and the generation of opsonic activity is among its most critical functions. The opsonic function of C3b renders the pathogen more easily phagocytosed.

The nature of the infections in complement-deficient individuals generally reflects the specific roles of the deficient component in host defense. For example, C3 is responsible for generating complement-mediated opsonic activity. Thus, patients with C3 deficiency are unduly susceptible to infection from encapsulated bacteria (e.g. *Streptococcus pneumoniae*,

*Haemophilus influenzae* and *Neisseria meningitidis*), organisms for which opsonization is a critical host defense mechanism.<sup>1-3</sup> In contrast, patients with deficiencies of C5, C6, C7, C8 or C9 possess C3 and their susceptibility is limited to *Neisseria*. Bactericidal activity, mediated by C5b through C9, is critical to defense against this genus. Interestingly, although a number of Gram-negative bacteria are susceptible to the bactericidal activity of complement, the susceptibility of patients with deficiencies of C5 through C9 appears to be limited to *Neisseria* spp.<sup>1,2</sup> The infections seen in complement-deficient individuals can be localized (e.g. pneumonia or sinusitis), although systemic infections (e.g. bacteremia/sepsis, meningitis or osteomyelitis) are common and often are recurrent.<sup>4</sup>

A number of studies have examined the prevalence of complement deficiencies among patients with characteristic infections. Although complement-deficient patients do not appear to be sufficiently common among patients with single episodes of pneumococcal, streptococcal or *H. influenzae* sepsis and/or meningitis to justify routine screening of patients with these infections, complement deficiencies are sufficiently common among patients with systemic neisserial infections to make routine screening worthwhile.<sup>5-7</sup> For example, estimates of the prevalence of complement deficiencies among patients with a single episode of meningococcal sepsis have varied from 5% to 15%. A study from South Africa demonstrated that 13% of patients with meningococcal disease had either C5 or C6 deficiency.<sup>8</sup> Not unexpectedly, the prevalence is as high as 40% if the patient has had recurrent meningococcal sepsis, has an infection with an uncommon serotype or has a positive family history of meningococcal systemic infections.<sup>9-12</sup>

## Pathophysiology of Systemic Autoimmune Disorders

Systemic lupus erythematosus (SLE) is common in patients with deficiencies of C1, C4, C2 and C3. A variety of pathophysiologic mechanisms exist by which complement deficiencies can lead to the development of systemic autoimmune disorders. The two most attractive relate to the role of the complement system in the processing and clearance of immune complexes and apoptotic cells.

The complement system is a major factor in the processing and clearance of immune complexes via a variety of mechanisms. First, immune complexes carrying C3b can be ingested by phagocytic cells.<sup>13,14</sup> Second, the activation of C3 by immune complexes maintains them as soluble complexes.<sup>15</sup> Third, humans possess receptors (CR1) for cleavage products of C3 on their erythrocytes, and circulating immune complexes containing C3b can reversibly bind to those receptors.<sup>16</sup> As erythrocytes

**TABLE 10-1** Functions of Complement Components

Components	Functions
C4a, C2a, C3a	Anaphylatoxins, histamine release
C3b	Opsonin, costimulation of B cells
C5a	Chemotaxis
C5, C6, C7, C8, C9	Membrane attack complex, lysis

carrying immune complexes pass through the liver, the immune complexes are picked off the surface by Kupffer cells, ingested and processed, thus effectively removing them from the circulation and preventing their deposition in other organs such as the kidney.<sup>17</sup>

The most important mechanism driving the susceptibility to systemic autoimmune disorders is the failure to clear apoptotic cells. The early components of the classical pathway, especially C1q, participate in the clearance of apoptotic cells.<sup>18,19</sup> As cells undergo apoptosis, intracellular constituents are reorganized and appear on the surface of the cell in blebs. Autoantigens targeted in patients with SLE are often found on the surface in these blebs, rendering a normally ‘invisible’ antigen ‘visible’.<sup>20</sup> Thus patients deficient in these components may develop SLE because they lack an important mechanism of clearance of apoptotic cells. Also contributing to the development of autoantibodies directed to nuclear antigens is the potential role of complement mediating B cell tolerance in the bone marrow.<sup>21</sup>

There are some clinical and laboratory features that are characteristic of SLE seen in complement-deficient individuals. For example, the SLE seen in C2-deficient patients is frequently associated with photosensitive dermatitis. It is not uncommon for C2-deficient patients to have low (or absent) titers of anti-nuclear antibody (ANA) or antibodies to double-stranded DNA (dsDNA), whereas the prevalence of anti-Ro antibodies in C2-deficient patients with lupus is greater than in non-C2-deficient patients.<sup>22,23</sup> Patients deficient in C1 or C4 usually have an early onset of clinical symptoms with prominent cutaneous manifestations.<sup>24,25</sup> SLE in C1- or C4-deficient individuals can be severe.

## Pathophysiology of Atypical Hemolytic Uremic Syndrome (HUS)

Factor H deficiency has been found to be the underlying basis for 15% to 30% of patients with atypical HUS.<sup>26,27</sup> The term atypical HUS refers to the fact that there is no antecedent diarrheal illness, which is seen in most sporadic forms of HUS.<sup>28</sup> The basis for the HUS in factor H deficiency is thought to be an inability to protect fenestrated endothelium in the glomerulus from complement-mediated damage.<sup>29</sup> Microtrauma arises frequently due to the high oncotic pressure and the damaged basement membrane is able to support complement activation if not protected by factor H. Interestingly, recurrent atypical HUS has been seen in patients with antibodies to factor H. Also supporting a role for factor H in the protection of basement membranes is the finding of a common polymorphism associated with macular degeneration.<sup>30</sup> The central region of the retina is gradually destroyed by a process that leaves a deposit of protein, termed drusen. These deposits contain complement components. It has been hypothesized that the abnormal factor

**TABLE 10-2** Clinical Characteristics of Inherited Complement Deficiency Diseases

Component	Inheritance	Major Clinical Expression
<b>CLASSICAL PATHWAY</b>		
C1q, C1r, C1s, C4, C2	Autosomal recessive	SLE and bacterial infections with encapsulated organisms
C3	Autosomal recessive	Glomerulonephritis, severe bacterial infections HUS can be due to gain-of-function mutations
<b>TERMINAL COMPONENTS</b>		
C5, C6, C7, C8, C9	Autosomal recessive	Neisseria
<b>REGULATORY PROTEINS</b>		
C1 inhibitor	Autosomal dominant	Angioedema
Factor B	Autosomal dominant Gain-of-function	HUS
Factor H	Variable	Infections and HUS
Factor I	Variable	Infections and HUS
MCP	Variable	Atypical HUS
Properdin	X-linked recessive	Neisseria
Factor D	Autosomal recessive	Neisseria

H provides less protection to the choroidal vessels, allowing smoldering complement activation and gradual damage to the endothelium. Additional complement regulatory protein deficiencies associated with atypical HUS alter the deposition of factor H or the function of the assembled complex. This activation of complement on endothelial cells is associated with microthrombi, and polymorphisms and mutations in plasminogen (which degrades thrombi) have also been found in atypical HUS.<sup>31</sup>

## Inherited Complement Deficiencies

Genetically determined deficiencies have been identified for most of the individual components of complement. Most are inherited as autosomal recessive traits, although one is inherited as an X-linked recessive trait (properdin deficiency), one is inherited as an autosomal dominant trait (C1 esterase deficiency), and the defects associated with HUS have variable patterns of inheritance (Table 10-2). Except where noted, the mutations are diverse and can lead to either absence of protein or production of a dysfunctional protein.

### C1q DEFICIENCY

C1q is one of the three subcomponents of C1; the other two are C1r and C1s. C1q is composed of six identical subunits, each of which is composed of three different polypeptide chains, C1qA, C1qB and C1qC.<sup>32</sup> IgG or IgM, after engaging antigen and forming an immune complex, binds C1q, which then activates C1r, in turn activating C1s. Activated C1s then cleaves both C4 and C2, creating the bimolecular enzyme C4b2a, which

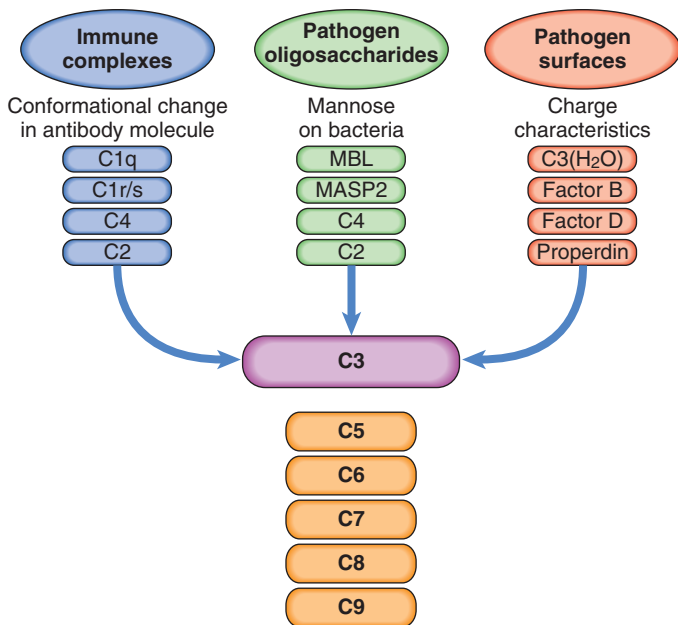

**Figure 10-1** The complement cascade. The classical pathway is activated primarily by antibody while the mannan binding lectin (MBL) and alternative pathways are activated directly by pathogens. In each case, the activation arm leads to cleavage of C3 and deposition of C3b onto the surface of the pathogen where it can act as an opsonin and costimulate B cells.

activates C3 and ultimately the terminal components (C5 through C9) via the classical pathway (Figure 10-1). Thus, C1q plays a critical role in activation of the classical pathway and the generation of the biologic activities of C3 and C5 through C9. In addition, recent studies have shown that C1q recognizes apoptotic cells and targets them for clearance.<sup>18,33</sup>

C1q-deficient individuals have markedly reduced serum total hemolytic activity and C1 functional activity. In most affected individuals, C1q protein level is also markedly reduced, but in some patients a dysfunctional immunoreactive protein is produced. There is a founder mutation in Turkey.<sup>34-37</sup>

The most prominent clinical manifestation of C1q deficiency is SLE. C1q-deficient patients carry the highest risk (>90% prevalence) of SLE among the complement deficiencies.<sup>1,2,38</sup> C1q-deficient patients have impaired clearance of the immune complexes and apoptotic cells and fail to tolerate B cells properly. The age of onset of SLE tends to be earlier, usually prepubertal, and the disease tends to be more severe.<sup>39</sup> Anti-dsDNA antibodies may be negative.

C1q-deficient individuals also have an increased susceptibility to encapsulated bacteria, reflecting their inability to activate the classical pathway and efficiently generate opsonically active C3b. In fact, nearly one third of C1q-deficient patients have significant bacterial infections and 10% have died of infections.<sup>1,2,38</sup> C1q, almost uniquely among complement components, is produced in substantial amounts by hematopoietic cells and a recent report documented a cure of SLE in a C1q-deficient patient who received a hematopoietic stem cell transplant.<sup>40</sup>

### C1r/C1s DEFICIENCY

The C1 complex is composed of six C1q subunits and two subunits each of C1r and C1s. The genes for C1r and C1s are

closely linked on chromosome 12 and encode highly homologous serine proteases. C1q, after it binds to an immune complex, activates C1r, which in turn activates C1s. It is C1s that cleaves C4 and C2, resulting in the assembly of the C3 cleaving enzyme C4b2a.

Patients with C1r deficiency have markedly reduced levels of total hemolytic complement activity and C1 functional activity.<sup>38</sup> Deficiency of C1r or C1s leads to reduced levels of the other, suggesting that neither is stable if not in the heterodimer.

The most common clinical expression of C1r/s deficiency has been SLE.<sup>1,2,38</sup> Some patients have also presented with glomerulonephritis or bacterial infections.

### C4 DEFICIENCY

The fourth component of complement (C4) is encoded by two closely linked genes (*C4A* and *C4B*) located within the major histocompatibility complex (MHC) on chromosome 6. Although the protein products of the two loci share most of their structure and function, there are four amino acid differences between them. The larger cleavage product of C4 is C4b which forms part of the bimolecular enzyme C4b2a that is responsible for activation of C3 and C5 through C9 via the classical pathway. It therefore plays an important role in the generation of the biologic activities of C3 and C5 through C9.

Because C4 is encoded by two distinct genes, patients with complete C4 deficiency are homozygous deficient at both loci (*C4A\*Q0*, *C4B\*Q0/C4A\*Q0*, *C4B\*Q0*).<sup>24,41</sup> In contrast to the rarity of patients with complete C4 deficiency, individuals who are heterozygous for either C4A or C4B deficiency are relatively common. Approximately 13% to 14% of the population is heterozygous for C4A deficiency and 15% to 16% is heterozygous for C4B deficiency, with the corresponding frequencies for homozygous-deficient individuals being 1% and 3%. Individuals who have complete C4 deficiency (i.e. are homozygous deficient for *both* C4A and C4B) have little, if any, total hemolytic activity in their sera and markedly reduced levels of C4 protein and functional activity. As a result of the absence of C4, these individuals have a markedly decreased ability to generate serum opsonic, chemotactic, tolerogenic and bactericidal activities via activation of the classical pathway.<sup>42</sup>

C4A deficiency is often the result of a large gene deletion<sup>43</sup> or a 2-base pair (bp) insertion in exon 29.<sup>44</sup> Some instances of C4B deficiency are the result of gene deletions. Finally, gene conversions can cause either C4A or C4B deficiency.<sup>45</sup>

Patients with complete C4 deficiency may present with SLE and/or an increased susceptibility to infection. The onset of SLE is usually early in life and is characterized by prominent cutaneous features such as photosensitive skin rash, vasculitic skin ulcers and Raynaud's phenomenon. Anti-dsDNA antibody may be absent.<sup>39</sup> Patients with complete C4 deficiency also have an increased susceptibility to bacterial infections and most deaths in C4-deficient patients are the result of infection.

Individuals who are homozygous deficient for C4A lack the isotype that is most efficient in interacting with proteins. The prevalence of homozygous C4A deficiency in patients with SLE is thought to be increased.<sup>46-49</sup> Interestingly, patients with SLE who have C4A deficiency have less neurologic and renal disease but more photosensitivity than other patients with SLE, and they have a lower prevalence of anticardiolipin, anti-Ro, anti-dsDNA and anti-Sm antibodies.<sup>50,51</sup>



In contrast to individuals with homozygous C4A deficiency, homozygous C4B-deficient individuals lack the C4 isotype that interacts most efficiently with polysaccharides. There is an increased prevalence of homozygous C4B deficiency in children with bacteremia and/or bacterial meningitis.<sup>52,53</sup>

## C2 DEFICIENCY

The second component of complement (C2) is encoded by a gene within the MHC on chromosome 6. Like C4, C2 is cleaved by C1s into two fragments, the larger of which (C2a) forms part of the C3-cleaving enzyme of the classical pathway, C4b2a. Thus C2, like C4, plays a critical role in generating the biologic activities of C3 and the terminal components C5 through C9.

C2-deficient patients usually have absent total hemolytic activity and less than 1% of the normal levels of C2 protein and function.<sup>54</sup> Serum opsonic, chemotactic and bactericidal activities are usually present but not generated as quickly or to the same degree as those in individuals who possess C2.

The majority of C2-deficient individuals (>95%) have the same molecular genetic defect, a 28-bp deletion at the 3' end of exon 6, which causes premature termination of transcription.<sup>55,56</sup> The deletion is associated with a conserved MHC haplotype consisting of *HLA-B18*, *C2\*Q0*, *Bf\*S*, *C4A\*4*, *C4B\*2*, and *DR\*2*.<sup>45-47</sup> This haplotype has a strong association with autoimmunity. C2 deficiency is the most common of the genetically determined complete complement deficiencies in Caucasians and the gene frequency of this deletion is between 0.05 and 0.007 in individuals of European descent, which translates into a prevalence of homozygotes of approximately 1 : 10,000.<sup>56,57</sup>

The most common clinical manifestation of C2 deficiency is SLE. Patients with C2 deficiency manifest many of the typical clinical features of SLE, although photosensitive cutaneous lesions are more common.<sup>58,59</sup> They also have a lower prevalence of anti-DNA antibodies than other patients with SLE, but the prevalence of anti-Ro and -La antibodies is higher.<sup>39</sup> Unlike C1 and C4 deficiencies, the SLE is not necessarily more severe than typical SLE.

An increased susceptibility to infection is also a prominent clinical presentation of C2 deficiency. The infections are usually caused by encapsulated pyogenic organisms such as *Pneumococcus*, *Streptococcus* and *H. influenzae* and are blood-borne, such as sepsis, meningitis, arthritis and/or osteomyelitis. Infection is the leading cause of death.<sup>58,59</sup> A recently described phenomenon in C2 deficiency that is likely common to other early component deficiencies is the accelerated atherosclerosis which significantly contributes to mortality.<sup>59</sup>

## C3 DEFICIENCY

The majority of serum C3 is derived from hepatic synthesis, although synthesis by monocytes, fibroblasts, endothelial cells and epithelial cells may contribute to local tissue content of C3. Whether activated by the classical or alternative pathways, C3 is cleaved into two fragments of unequal sizes. The smaller, C3a, is an anaphylatoxin, whereas the larger, C3b, is an opsonin and also forms part of the classical and alternative pathway enzyme (C4b2a3b) that activates C5 and the membrane attack complex. Thus, C3 is not only critical in generating C3-mediated serum opsonizing and anaphylatoxic activities, but also in generating the chemotactic and bactericidal activities of C5 through C9.

Patients with C3 deficiency usually have less than 1% of the normal level of C3 in their sera. Similarly, serum opsonic, chemotactic and bactericidal activities are also markedly reduced. The mutations responsible for C3 deficiency in humans have been diverse. However, there is a relatively common 800-bp deletion found among Afrikaans-speaking South Africans (gene frequency of 0.0057).<sup>60,61</sup>

C3-deficient patients have very severe infections.<sup>62</sup> Patients tend to present in very early childhood. Although the most common infections are blood-borne infections caused by pyogenic bacteria such as *Pneumococcus*, *H. influenzae* and *Meningococcus*, localized infections such as pneumonia and sinusitis have also been reported.

Autoimmune diseases are also relatively common in patients with C3 deficiency. Some patients have arthralgias and vasculitic skin rashes (similar to serum sickness), associated with active infection. Most patients have membranoproliferative glomerulonephritis. True SLE is less common in C3 deficiency than in the other early component deficiencies.

The membranoproliferative glomerulonephritis in C3 deficiency<sup>62</sup> is characterized by proliferation, an increase in the mesangial matrix, and electron-dense deposits in both the mesangium and subendothelium of the capillary loops. Immunofluorescent studies have revealed the presence of immunoglobulins in the kidney, and circulating immune complexes may be present in the serum, suggesting that membranoproliferative glomerulonephritis in these patients is the result of immune complex deposition.

## C5 DEFICIENCY

The gene encoding the fifth component of complement (C5) is on the short arm of chromosome 9. When C5 is activated, it is cleaved into two fragments of unequal size. The smaller fragment, C5a, is a potent chemotactic fragment, and the larger, C5b, initiates assembly of the membrane attack complex, C5b through C9, and is critical for bactericidal activity (Figure 10-1).

The most common clinical expression of C5 deficiency is an increased susceptibility to systemic neisserial infections.<sup>1,2</sup>

## C6 DEFICIENCY

The genes for C6 and C7 are located near each other on the long arm of chromosome 5. C6 participates in the formation of the membrane attack complex and therefore plays a critical role in the generation of bactericidal activity. The usual form of C6 deficiency is characterized by absent total serum hemolytic activity and very low levels (<1%) of serum C6. Another form of C6 deficiency, subtotal C6 deficiency (C6SD), is characterized by 1% to 2% of the normal levels of C6 and levels of total hemolytic activity that are reduced but present.<sup>63</sup>

The most common mutation causing C6 deficiency is a single base pair deletion at position 879.<sup>64,65</sup> Interestingly, the mutations among African Americans are different from those in the African population.<sup>66,67</sup> C6SD is the result of a loss of the splice donor site of intron 15 and results in a truncated C6 that can support some lytic activity.<sup>63</sup>

C6 deficiency is one of the most common complement deficiencies. Among African Americans in the USA, it is reported to be as common as 1 : 1,600 individuals (0.062%).<sup>67</sup> It is thought to be uncommon among individuals of European

descent. Like other terminal components, C6 deficiency is associated with systemic neisserial infections.

### C7 DEFICIENCY

C7 participates in the formation of the membrane attack complex and therefore is critical to the generation of serum bactericidal activity. Patients who are deficient in C7 have markedly reduced serum total hemolytic activity and C7 levels. As expected, their serum bactericidal activity is similarly reduced.<sup>68</sup>

Like other patients with deficiencies of the terminal components (C5, C6, C7, C8 and C9), the most prominent clinical manifestation of C7 deficiency is an increased susceptibility to systemic neisserial infections. A few patients have presented with SLE, rheumatoid arthritis, pyoderma gangrenosum and scleroderma, but it is unclear whether these are pathophysiologically related to the C7 deficiency.

### C8 DEFICIENCY

C8 is comprised of three different polypeptide chains ( $\alpha$ ,  $\beta$  and  $\gamma$ ), which are encoded by separate genes (*C8A*, *C8B* and *C8G*). The genes *C8A* and *C8B* map to the short arm of chromosome 1, and the gene *C8G* maps to the long arm of chromosome 9. The alpha and gamma chains are covalently linked to form one chain (C8  $\alpha$ - $\gamma$ ), which is joined to the C8  $\beta$  chain by noncovalent bonds. C8 is an integral part of the pore-forming membrane attack complex C5b-9 and, as such, plays a critical role in the generation of complement-mediated bactericidal activity.

There are two forms of C8 deficiency and each is inherited as an autosomal recessive trait. In one form, patients lack the C8  $\beta$  subunit, whereas in the other form the  $\alpha$ - $\gamma$  subunit is deficient.<sup>69,70</sup> In either form, total hemolytic activity is absent from the serum, as is functional C8 activity. However, some C8 antigen can usually be detected in C8  $\beta$  deficiency because patients possess the C8  $\alpha$ - $\gamma$  subunit. In contrast, patients with C8  $\alpha$ - $\gamma$  deficiency usually have undetectable C8 antigen with standard immunochemical techniques. As expected, patients with either form of the deficiency have a marked reduction in serum bactericidal activity.

C8  $\beta$  deficiency is more common among individuals of European descent and C8  $\alpha$ - $\gamma$  deficiency is more common among individuals of African descent. Approximately 86% of C8  $\beta$ -null alleles are the result of C-to-T transition in exon 9, which results in the generation of a premature stop codon.<sup>70,71</sup> Only a limited number of patients with C8  $\alpha$ - $\gamma$  deficiency have been examined, and in most instances an intronic mutation alters the splicing of exons 6 and 7 of the C8A chain and creates an insertion that generates a premature stop codon.<sup>72</sup>

As in deficiencies of other components of the membrane attack complex, systemic neisserial infections have been the predominant clinical presentation of C8 deficiency.<sup>72</sup>

### C9 DEFICIENCY

The gene for C9 is located on the short arm of chromosome 5. The protein product has sequence homology to other members of the membrane attack complex. Affected individuals have markedly reduced levels of both C9 antigen and functional activity. However, the hemolysis of antibody-sensitized erythrocytes can occur with the insertion of a membrane attack

complex lacking C9 (i.e. C5b-8) and thus is not strictly dependent on C9. Therefore, patients with C9 deficiency have some total hemolytic activity, although it is reduced to between one third and one half of the lower limit of normal.<sup>73-76</sup> Similarly, their sera possess some bactericidal activity, although the rate of killing is significantly reduced.

Genetically determined C9 deficiency is uncommon in general, but is relatively common among individuals of Japanese and Korean descent.<sup>74,77</sup> A nonsense mutation in exon 4 has a gene frequency of 1 : 1,000 in Japanese populations.<sup>74,78</sup> Individuals with C9 deficiency have an increased susceptibility to systemic neisserial infections, although the susceptibility appears to be mitigated by the residual bactericidal activity in these individuals.<sup>79,80</sup>

### MANNAN BINDING LECTIN DEFICIENCY

Mannan binding lectin (MBL) deficiency was initially identified in a cohort of hospitalized patients with infectious diseases. It is now known that it is quite common, with 2% to 7% of people having MBL deficiency.<sup>81</sup> There are structural polymorphisms that destabilize the higher order complexes and several promoter mutations that compromise production. The mutations/polymorphisms exist in haplotypes of varying severity.

MBL deficiency has, at most, a modest effect on infection susceptibility. Similarly, it represents a modest risk factor or disease modifier in autoimmune diseases such as SLE or rheumatoid arthritis.

### MANNAN BINDING LECTIN ASSOCIATED SERINE PROTEASE 2 (MASP2) DEFICIENCY

Mutations and polymorphisms in MASP2 are common and have variable effects on function.<sup>82</sup> MASP2 cleaves C4 and C2 to form the same C3 convertase as the classical pathway. The Asp105Gly variant in MASP2 leads to impaired binding to MBL. Although it was originally described in a patient with recurrent pneumonia and ulcerative colitis, subsequent studies have not identified an increased susceptibility to infection.<sup>83-85</sup>

### C1 ESTERASE INHIBITOR DEFICIENCY

C1 esterase inhibitor (C1-INH) is encoded by a gene on the long arm of chromosome 11. C1-INH binds covalently to C1r and C1s, leading to dissociation of the C1 macromolecular complex and inhibition of the enzymatic actions of C1r and C1s. Genetically determined C1 esterase inhibitor deficiency is inherited as an autosomal dominant trait. In the most common form (type I), accounting for approximately 85% of the patients, the sera of affected individuals are deficient in both C1-INH protein (5-30% of normal) and C1-INH function.<sup>86,87</sup> In the other less common form (type II), a dysfunctional protein is present in normal or elevated concentrations, but the functional activity of C1-INH is markedly reduced.<sup>88,89</sup> In either case, C4 levels are usually reduced below the lower limit of normal, both during and between attacks, because of the uncontrolled cleavage by C1s.

C1-INH is the major inhibitor of kallikrein and C1, and therefore diminished levels of C1-INH lead to unregulated activation of the classical pathway and kallikrein after exposure to a mild trigger (Figure 10-2).<sup>90-92</sup> Complement anaphylatoxins are thought to play a minor role in the process and bradykinin is the major mediator of the angioedema.<sup>93</sup>

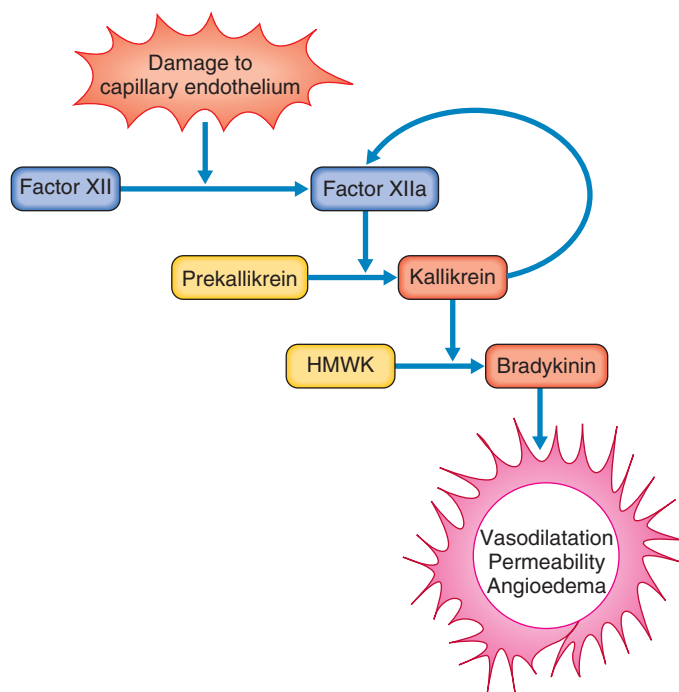

**Figure 10-2** The role of C1 inhibitor in angioedema. The edema in C1 inhibitor deficiency is due primarily to activation of bradykinin. Factor XII (Hageman factor) is activated by exposure to damaged capillary vessels. Kallikrein performs two roles: it acts to cleave bradykinin from high molecular weight kinogen (HMWK), and it acts to enhance factor XIIa activation.

C1-INH deficiency is responsible for most cases of the clinical disorder of hereditary angioedema (HAE). The clinical symptoms of HAE are the result of submucosal or subcutaneous noninflammatory edema.<sup>94</sup> The three most prominent areas of involvement are the skin, upper respiratory tract and gastrointestinal tract.<sup>95</sup>

Attacks involving the subcutaneous tissue may involve an extremity, the face, or genitalia. In some instances, there may be changes immediately preceding the edema such as subtle mottling, a transient serpiginous erythema or frank erythema marginatum. The edema usually expands outward from a single site and may vary in size from a few centimeters to the involvement of a whole extremity. The lesions are characteristically nonpruritic. However, early in the development of the lesion, there may be a feeling of tightness in the skin because of the accumulation of subcutaneous fluid. Attacks usually progress for 1 to 2 days and resolve over an additional 2 to 3 days.

Attacks involving the upper respiratory tract represent a significant cause of morbidity and occasionally death. In one series published in 1976, pharyngeal edema had occurred at least once in nearly two thirds of the patients.<sup>87</sup> Laryngeal edema, accompanied by hoarseness and stridor, occurs and progresses to respiratory obstruction. This is a life-threatening emergency. In fact, in that same series, tracheotomies had been performed in 1 of every 6 patients with HAE.<sup>87</sup> Today, with improved treatment, this is becoming less common.

Symptoms in the gastrointestinal tract are related to edema of the bowel wall and may include anorexia, dull aching of the abdomen, vomiting and, in some cases, crampy abdominal pain. Abdominal symptoms are often prominent in childhood and can occur in the absence of concurrent cutaneous or pharyngeal involvement. In some instances, abdominal symptoms

may be the only symptoms the patient has ever had, leading to difficulty in diagnosis.<sup>96</sup> The abdominal pain may be so severe that it mimics an acute abdomen and some patients have suffered unnecessary exploratory laparotomies prior to their diagnosis of HAE.

Although the onset of symptoms occurs in more than half of the patients before adolescence, some patients do not experience their first symptoms until they are well into adult life. In just over half of the patients, no specific event can be clearly identified as initiating attacks, although anxiety and stress are frequently cited. Dental extractions and tonsillectomy can initiate edema of the upper airway, and cutaneous edema may follow trauma to an extremity. Some patients report attacks after the use of tight-fitting clothing or shoes, whereas others have related cold exposure to the onset of symptoms.<sup>97</sup>

A potential source of diagnostic confusion is the association of HAE with SLE, presumably because the secondary reduction of C4 predisposes to SLE. These patients can be quite difficult to diagnose and manage.

### FACTOR H DEFICIENCY

The basis for the HUS in factor H deficiency is thought to be an inability to protect fenestrated endothelium in the glomerulus from complement-mediated damage (see 'Pathophysiology of atypical hemolytic uremic syndrome').<sup>29</sup>

Neisserial infections are also seen in patients with factor H deficiency, and the mutations in patients with HUS and neisserial infections are distinct. The infections arise due to unregulated consumption of C3.<sup>62,98,99</sup>

HUS is a microangiopathy typically associated with hemolytic anemia, thrombocytopenia and renal failure. Atypical HUS has a mortality rate of 25% and half of the patients develop renal failure.<sup>28,100</sup> Factor H deficiency is responsible for 15% to 30% of patients with atypical HUS.<sup>26</sup> Both autosomal recessive and heterozygous mutations have been seen. The age of onset is quite young in most cases and the disease is often recurrent.<sup>101</sup> Normal complement (C3, AH50 and factor H) levels are sometimes seen and the only way in which this disorder can be confidently identified is with direct mutation analysis. A common tyrosine-to-histidine polymorphism of factor H was identified as a significant risk factor for macular degeneration in a genome-wide linkage study.<sup>102</sup>

### FACTOR I DEFICIENCY

The gene for factor I is located on the long arm of chromosome 4. Factor I is a serine protease that cleaves C3b to produce iC3b, an inactive cleavage product that cannot function in the C3-cleaving enzyme of the alternative pathway. Patients with factor I deficiency have uncontrolled activation of C3 via the alternative pathway.<sup>103,104</sup> Patients with factor I deficiency therefore have a secondary consumption of C3 with markedly reduced levels of C3 in their sera and a corresponding decrease in serum opsonic, bactericidal and chemotactic activity.<sup>103,104</sup> In general, the patients with atypical HUS due to factor I deficiency have heterozygous mutations and the mutations do not localize to a specific protein domain.<sup>105</sup> The mutations associated with infection and atypical HUS are distinct.

An increased susceptibility to infection is a common presentation.<sup>103</sup> Like patients with C3 deficiency, factor I deficient patients have infections caused by encapsulated pyogenic bacteria such as *Streptococcus*, *Pneumococcus*, *Meningococcus* and *H.*

*influenzae*, organisms for which C3 is an important opsonic ligand. Also like patients with C3 deficiency, some patients have had elevated levels of circulating immune complexes. In fact, there has been one report of a transient illness resembling serum sickness characterized by fever, rash, arthralgia, hematuria and proteinuria.

A second presentation is atypical HUS. Factor I deficiency is responsible for 5% to 10% of patients with atypical HUS.<sup>26,106,107</sup> These patients have a phenotype indistinguishable from that of patients with factor H deficiency.

### MEMBRANE COFACTOR PROTEIN (CD46) DEFICIENCY

Membrane cofactor protein is a widely expressed glycoprotein that inhibits complement activation on host cells. It is a cofactor for factor I-based cleavage of C3b and C4b. Deficiencies of membrane cofactor protein (MCP) are associated with atypical HUS although the presentation is usually later and milder than in patients with factor H or factor I deficiencies.<sup>101,108–110</sup> MCP mutations account for approximately 10% of all atypical HUS. MCP is expressed on renal tissues and therefore renal transplantation can be successful. Traditional complement analyses are normal although the mechanism of disease is thought to be the same as for factor H and factor I deficiencies.

### PROPERDIN DEFICIENCY

Properdin is the only gene of the complement system that is encoded on the X chromosome. Properdin stabilizes the alternative pathway C3 and C5 convertases by extending the half-lives of the C3 and C5 converting enzymes. Properdin deficiency is inherited as an X-linked recessive trait. The protein may be absent or reduced in the serum, depending on the specific mutation. Patients with properdin deficiency have absent function of the alternative pathway. Similarly, serum bactericidal activity for some strains of meningococci is reduced in properdin-deficient serum.<sup>111</sup>

Approximately 50% of the patients described with properdin deficiency have had systemic meningococcal disease.<sup>1,2,111</sup> Isolated cases of SLE and discoid lupus have also been seen in properdin-deficient patients, but these may represent ascertainment bias.

### FACTOR D DEFICIENCY

Neisserial infections are seen in factor D deficiency.<sup>1,2,112</sup> Systemic streptococcal infections have also been seen. Other complement levels are typically normal in factor D deficiency, however there is almost no ability to activate the alternative pathway.

## Management of Genetically Determined Complement Deficiencies

### Prevention of Infectious Diseases

Two strategies have been attempted to reduce susceptibility to infections and/or modify the clinical course of infections in patients with genetically determined deficiencies of complement. One strategy is to immunize these patients against common bacterial pathogens such as *Pneumococcus*, *H. influenzae* and *Meningococcus*. Unfortunately, because the

complement system participates in the generation of a normal immune response,<sup>113</sup> complement-deficient patients may not respond as well as complement-sufficient hosts.<sup>114</sup> Another limitation to the use of immunization in complement-deficient patients is that the vaccines may not include all of the serotypes to which complement-deficient patients are susceptible. Although there are limitations, data support the use of repeated meningococcal vaccination to mitigate the risk of infection for patients with terminal complement component deficiencies.<sup>115</sup> The Centers for Disease Control recommend a two dose series of the quadrivalent conjugated meningococcal vaccine before 2 years of age for high-risk patients. A subsequent dose after 3 years and then every 5 years is the current recommendation. It seems reasonable to consider repeated vaccination for *Pneumococcus* and *H. influenzae* for patients with defects in early complement components. Guidelines should be monitored and protocols amended as necessary because nonconjugated vaccine administration can interfere with subsequent conjugated vaccine responses.<sup>115–117</sup>

A second strategy in the prevention of infection is the use of prophylactic antibiotics. Because patients with complement deficiencies have a high risk of recurrent episodes of blood-borne infections and because immunizations may not afford them complete protection, some patients have been placed on antibiotic prophylaxis. Any recommendation for antibiotic prophylaxis must be viewed in the context of the emergence of antibiotic resistance among bacteria.

### Management of Autoimmune Disorders

Regardless of the disorder, autoimmune conditions are most often treated with the same immunosuppressive agents and antiinflammatory medications as one would use in a complement-sufficient patient. Most autoimmune disorders are associated with an increased risk of atherosclerosis in their own right and the early complement component deficiencies appear to add to that risk. Therefore, aggressive management of cardiac risk factors is advisable.

### Management of Angioedema

The treatment of C1-INH deficiency is different from that of other complement deficiencies in that there are specific measures available to ameliorate symptoms and to prevent recurrence.<sup>118</sup> In some patients, episodes of angioedema may be sufficiently frequent or difficult to manage to justify long-term prophylaxis. Attenuated androgens such as oxandrolone and danazol are highly effective<sup>119,120</sup> and act by increasing transcription of the normal allele of *C1INH*.<sup>121</sup> However, because of their androgenic effects, their use has declined significantly, especially in females.

Another class of agents historically used for long-term prophylaxis is the antifibrinolytic agents.<sup>122,123</sup> Tranexamic acid and aminocaproic acid act by blocking plasmin generation. Although their efficacy is less than that of attenuated androgens, the incidence of side-effects is also less than that of attenuated androgens. For this reason, these agents may be used in childhood, although they are quite difficult to obtain in the USA. C1 inhibitor concentrate is approved both for use as prophylaxis and treatment of acute attacks.<sup>124,125</sup> Twice-weekly intravenous administration and cost for prophylaxis will be barriers for some patients.

Management of angioedema also requires education of the family and cautions against estrogen-containing birth control pills, undue exposure to trauma and use of angiotensin



converting enzyme inhibitors.<sup>118</sup> All of these are known to precipitate episodes.

In some instances, patients may require short-term prophylaxis for surgery or oral procedures. Attenuated androgens, fibrinolytic agents, fresh frozen plasma (FFP) and C1 esterase concentrate have all been used successfully for short-term prophylaxis, but most major medical centers now use C1 inhibitor concentrate. Recent guidelines can be helpful.<sup>118</sup>

Acute attacks can be emergencies and patients should have an action plan that includes contingencies for airway involvement. C1 esterase inhibitor concentrate is an effective acute treatment.<sup>96,126</sup> Ecallantide and icatibant are also approved for treatment. Ecallantide is a kallikrein inhibitor and icatibant is a bradykinin receptor antagonist. The former requires a health-care worker to administer and monitor for anaphylaxis, an uncommon adverse event. Icatibant has a slower onset of action but has the advantage of self administration. Epinephrine, antihistamines and corticosteroids are of no proven benefit in C1-INH deficient patients. FFP has some advocates, however there are limited clinical data on its use.<sup>127</sup>

### Management of HUS

As is done for thrombotic thrombocytopenic purpura (TTP), most patients with atypical HUS receive apheresis and FFP replacement for acute episodes.<sup>101,108</sup> Factor H replacement may be of benefit, and FFP may be used to replace factor H. In the case of MCP deficiency, where the affected protein is membrane bound, it is less clear that pheresis and FFP would provide benefit, but it could potentially act to clear inciting agents or complement activation products. Eculizumab, a C5 inhibitor, has been approved as treatment for atypical HUS due to complement deficiencies.<sup>128</sup> The appropriate use of eculizumab in this setting is still being defined. For patients with factor H or factor I deficiency and end-stage renal disease, renal transplantation is not recommended. In contrast, renal disease in MCP typically does not recur in the transplanted kidney.

## Secondary Complement Deficiencies

Secondary complement deficiencies are relatively common. Any pathologic process that results in activation of the complement cascade or interferes with the synthesis of complement components, such as liver disease, can result in a secondary complement deficiency.

### THE NEWBORN

In full-term infants, the levels of most components of either the classical or alternative pathways are 50% to 80% of adult levels.<sup>129</sup> However, both C8 and C9 seem to be more severely depressed, with levels in full-term newborn infants as low as 28% and 10%, respectively, of maternal levels.<sup>130,131</sup> The serum levels of individual components of complement in premature infants have also been studied. C4, C3, C7, C9, factor B, properdin and C1 esterase inhibitor have been detected in fetal serum as early as the end of the first trimester or the beginning of the second trimester.<sup>132,133</sup>

### NEPHROTIC SYNDROME

Loss of complement proteins in the urine, particularly factor B,<sup>134</sup> contributes to the increased susceptibility to infection.

## SYSTEMIC LUPUS ERYTHEMATOSUS

SLE is a systemic disorder in which immune complexes are generated and deposited in end organs, leading to the classical inflammatory pathologic changes. The immune complexes may activate the complement cascade, leading to consumption of individual components such as C3 and C4. The activation and consumption of the complement system typically precedes clinical flare, and the degree of hypocomplementemia, specifically levels of C3 and C4, generally reflects the degree of clinical activity.<sup>135–138</sup> Although complement activation as a result of the circulating immune complexes is particularly characteristic of SLE, it has also been described in juvenile rheumatoid arthritis, Sjögren's syndrome, a variety of vasculitides, and mixed connective tissue disease. Hypocomplementemia as a result of immune complex formation is seen less frequently in other autoimmune diseases.

### SERUM SICKNESS

Serum sickness is the consequence of immune complex formation in response to the administration of drugs (e.g. penicillin, cefaclor and minocycline), foreign proteins (e.g. antithymocyte globulin, therapeutic monoclonal antibodies or antivenoms) or, in some instances, infections.<sup>139,140</sup> Although rash, fever and arthralgia/arthritis are the most common clinical findings, severe cases may progress to renal involvement.<sup>141</sup> Immune complexes are present in the circulation early in the process. Most cases have significant hypocomplementemia which, when it occurs, is characterized by low CH50, C3 and C4 levels.<sup>142,143</sup>

### SEPSIS

Acute bacterial sepsis, specifically Gram-negative sepsis, may be associated with transient hypocomplementemia characterized by low levels of C3 and C4, as well as low total hemolytic activity (CH50).<sup>144</sup> The hypocomplementemia is most commonly found in patients who have some degree of cardiovascular compromise and is strongly correlated with the severity of the shock and morbidity.

### CIRRHOSIS

Patients with cirrhosis have decreased serum concentrations of C3, C4 and total hemolytic activity due to diminished synthesis.<sup>145</sup> There is a correlation between the low levels of C3 and a predisposition to spontaneous bacterial peritonitis and mortality in cirrhosis.<sup>146</sup>

### CARDIOPULMONARY BYPASS, EXTRACORPOREAL MEMBRANE OXYGENATION AND HEMODIALYSIS

These interventions bring the patient's blood in contact with artificial surfaces or membranes. As a result, there may be activation of the complement system. As a consequence of the activation of the complement system, there also is generation of biologically active cleavage products such as C3a and C5a. A number of studies have suggested that the generation of these anaphylatoxins is responsible for the generalized inflammatory response that follows cardiopulmonary bypass (post-perfusion syndrome) and hemodialysis (pulmonary neutrophil sequestration).<sup>147</sup>

**MALNUTRITION**

Malnutrition (both kwashiorkor and marasmus) is associated with decreased levels of serum total hemolytic complement activity as well as most of the individual components of complement, such as C3 and C5.<sup>148,149</sup> The degree of the decrease in complement components, such as C3, correlates strongly with serum albumin, suggesting that the decrease is the result of poor synthetic function in the liver.

**PAROXYSMAL NOCTURNAL HEMOGLOBINURIA**

Paroxysmal nocturnal hemoglobinuria (PNH) is characterized by recurrent episodes of hemoglobinuria due to intravascular hemolysis and is associated with acquired somatic mutations of *PIG-A* or *PIG-T* in a clone of bone marrow progenitor cells.<sup>150,151</sup> The protein product of *PIG-A* is required for GPI anchored proteins. C8 binding protein, DAF and CD59 are GPI anchored proteins that protect hematopoietic cells from complement-mediated lysis. The red cells are the most vulnerable because they have no ability to repair membrane damage. PNH can be associated with complement dysfunction. Inherited CD59 deficiency has been associated with a PNH-like syndrome.<sup>152</sup>

**Laboratory Assessment of Complement**

A CH50 assay consists of adding patient serum to antibody-coated sheep red cells. Complement activation of C1 to C9 leads to lysis. A CH50 result reports the dilution of serum capable of

lysing 50% of the sheep cells coated with immunoglobulin (e.g. rabbit IgM anti-sheep red blood cell [RBC] antibodies). The function of the alternative pathway is measured by RBC lysis in the absence of immunoglobulin. With the exception of C9 deficiency, genetic deficiencies of any of the classical initial pathway or terminal (C5–C8) cascade components lead to a CH50 of zero or near zero. A finding of low levels of CH50 or AH50 should be repeated and appropriate handling of the serum should be ensured. Complement components are consumed quickly once blood has been drawn. Other causes of low, but not absent, CH50 results are complement consumption due to infection or autoimmune disease. Less common, but medically more important, are the regulatory protein defects leading to consumption of C3 such as factor D, factor H and factor I deficiency. C9 deficiency also leads to a reduction in both the CH50 and AH50 (Figure 10-3). Nephritic factors (antibodies to complement components) can lead to a chronically low CH50, AH50 or both.

Once an abnormal CH50 or AH50 has been confirmed, nephelometry is used to define the serum levels of certain components (C3 and C4 primarily) and enzyme-linked immunosorbent assays (ELISAs) are available for certain other components. Individual component functional assays are not widely available but are available through reference laboratories. Once the specific diagnosis is established, the management path becomes clearer.

Patients with recurrent sinopulmonary infections are infrequently found to have complement deficiencies. For patients with recurrent sepsis/systemic infection or sepsis on the background of autoimmune disease (or a family history of autoimmune disease), the frequency of identifying a complement

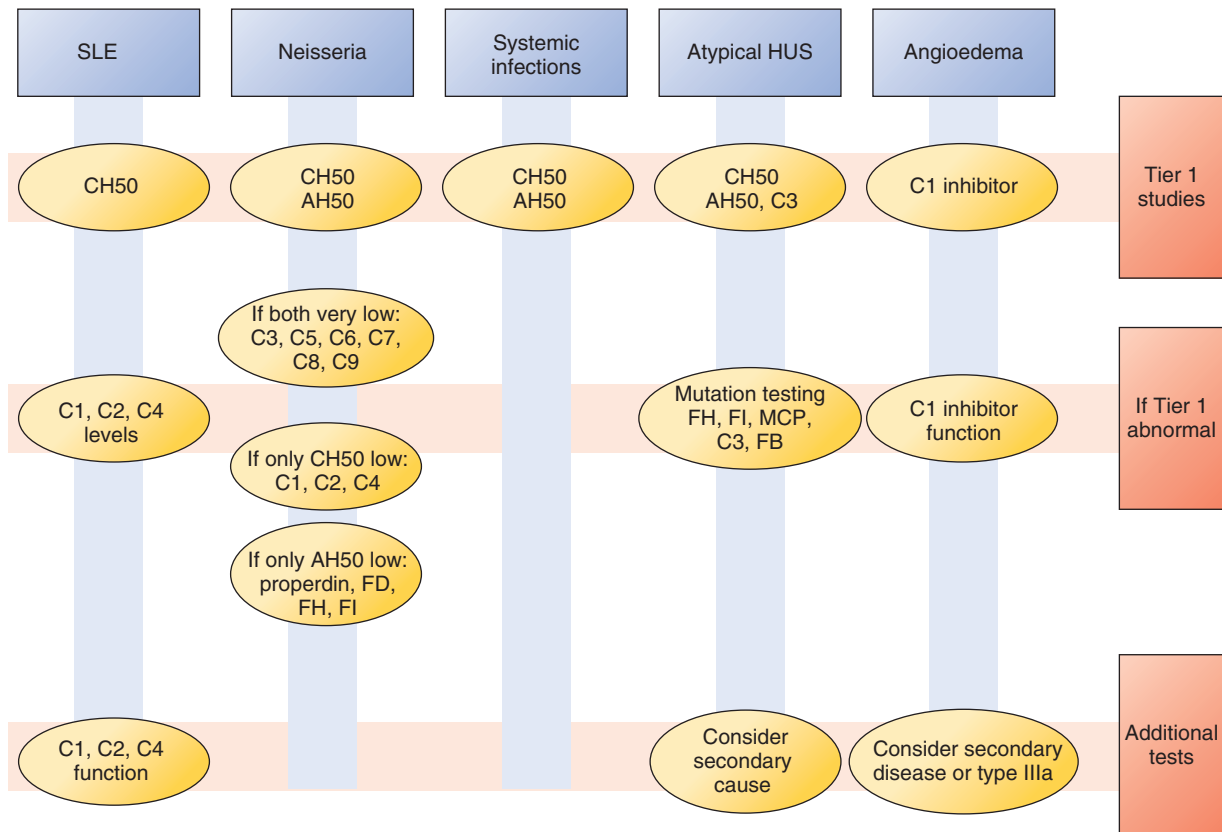

**Figure 10-3** A potential algorithm for the evaluation of patients with suspected complement deficiency.

defect is probably higher although there are no data to support this approach.<sup>153</sup> Patients with a single meningococcal infection, either meningitis or meningococemia, probably deserve an evaluation in nonendemic areas.<sup>154,155</sup> The evaluation would include a CH50 and AH50. There is general consensus that patients with meningococcal disease with an unusual serotype, with meningococcal disease on the background of a positive family history or recurrent meningococcal disease, should have an evaluation with a CH50 and AH50. In these patient groups, the frequency of complement deficiency approaches 50%.<sup>155,156</sup> Chronic meningococemia appears to be another condition with a high frequency of complement deficiency.<sup>10</sup>

Most Caucasian SLE cohorts have approximately 1% to 2% of patients with complement deficiency (generally C2 deficiency).<sup>56,138</sup> Given the high rate of infection, it is important to identify these patients. Patients with C1 and C4 deficiencies tend to have severe disease with early presentations and therefore testing pediatric-onset severe SLE might be more revealing of complement deficiencies. An additional category where a CH50 assay might be considered is in the evaluation of patients with clinical symptoms suggestive of SLE but with negative ANA and anti-dsDNA. While these autoantibodies are often thought of as important indicators of SLE, complement-deficient patients have them less frequently and it might support the diagnosis of SLE to know that the patient had a complement deficiency.

All patients with atypical HUS should have a complement evaluation. A CH50, an AH50 and a C3 level should be obtained. In many cases, these will be normal and measurement in serum and/or mutation analysis of factor H, factor I, MCP, C3 and factor B will most often be required. Patients with membranoproliferative glomerulonephritis type II should also be evaluated when the clinical suspicion of a complement deficiency or nephritic factor exists.

When angioedema occurs in the setting of a known allergic response, it is much less likely to be due to C1 inhibitor deficiency. Patients with recurrent angioedema in the absence of allergic reactions, patients with a family history of angioedema, patients with angioedema preceded by a reticular rash and patients with angioedema after trauma should all have an evaluation. Note that HAE is not associated with urticaria. Angioedema associated with urticaria is extremely unlikely to represent HAE. A simple but rather insensitive screen is to measure C4 levels. C4 is typically decreased at baseline but is diminished even more during an acute attack owing to consumption. A more specific strategy is to measure C1 inhibitor antigen and functional levels.

## Conclusions

Complement represents a bridge between innate and adaptive immunity. It is important for the phagocytosis of immune

### BOX 10-1 KEY CONCEPTS

#### Clinical Presentations of Complement Deficiencies

- Increased susceptibility to systemic or deep bacterial infection
  - Classical complement component deficiencies are associated with systemic infections with encapsulated organisms
  - Terminal component deficiencies are associated with susceptibility to infection with *Neisseria*
- Systemic lupus erythematosus, especially with early components of the classical pathway
- Hereditary angioedema is due to haploinsufficiency of C1 esterase inhibitor, a regulatory protein
- Atypical hemolytic uremic syndrome, predominantly with defects of factors H and I and membrane cofactor protein

complexes, opsonization of bacteria, lysis of bacteria, solubilizing of immune complexes and elimination of apoptotic cells. Complement deficiencies manifest themselves either as susceptibility to recurrent infections or as susceptibility to autoimmune/immune complex-mediated diseases (Box 10-1). Deficiencies of early components of the classical complement cascade (C1, C2, C4 and C3) are associated with both autoimmune/immune complex diseases and susceptibility to infections. Deficiencies of components of the alternate pathway (factor H, factor I, factor D and properdin) and of late components of the complement system C5 to C9 are associated with susceptibility to infections, primarily to neisserial infections in the case of deficiency of C5 through C9. The diagnosis of a complement component deficiency must be entertained in all patients with recurrent severe bacterial infections, particularly in the face of elevated or upper-range levels of serum immunoglobulins and adequate antibody titers. The diagnosis of a deficiency in the early components of the classical complement cascade must be entertained in cases of SLE with a history of significant infection, and defects in regulatory proteins should be sought in cases of atypical HUS. A diagnosis of C1 esterase inhibitor deficiency must be considered in cases of nonpruritic angioedema in the absence of urticaria, particularly in the presence of a similar family history and in cases precipitated by trauma. Fortunately, treatment and education regarding risk can be life saving.

#### ACKNOWLEDGMENTS

Jerry Winkelstein's wisdom and passion for complement are gratefully acknowledged. He co-authored the original version of this chapter.

The complete reference list can be found on the companion Expert Consult website at <http://www.expertconsult.inkling.com>.

## KEY REFERENCES

1. Figueroa JE, Densen P. Infectious diseases associated with complement deficiencies. *Clin Microbiol Rev* 1991;4:359–95.
2. Ross SC, Densen P. Complement deficiency states and infection: epidemiology, pathogenesis and consequences of neisserial and other infections in an immune deficiency. *Medicine* 1984;63:243–73.
21. Chatterjee P, Agyemang AF, Alimzhanov MB, Degen S, Tsiftoglou SA, Alicot E, et al. Complement C4 maintains peripheral B-cell tolerance in a myeloid cell dependent manner. *Eur J Immunol* 2013;43:2441–50.
33. Navratil JS, Ahearn JM. Apoptosis and autoimmunity: complement deficiency and systemic lupus erythematosus revisited. *Curr Rheumatol Rep* 2000;2:32–8.
108. Caprioli J, Noris M, Brioschi S, Pianetti G, Castelletti F, Bettinaglio P, et al. Genetics of HUS: the impact of MCP, CFH, and IF mutations on clinical presentation, response to treatment, and outcome. *Blood* 2006;108:1267–79.
110. Zimmerhackl LB, Besbas N, Jungraithmayr T, van de Kar N, Karch H, Karpman D, et al. Epidemiology, clinical presentation, and pathophysiology of atypical and recurrent hemolytic uremic syndrome. *Semin Thromb Hemost* 2006;32:113–20.
118. Bowen T, Cicardi M, Farkas H, Bork K, Kreuz W, Zingale L, et al. Canadian 2003

- international consensus algorithm for the diagnosis, therapy, and management of hereditary angioedema. *J Allergy Clin Immunol* 2004;114:629–37.
124. Waytes AT, Rosen FS, Frank MM. Treatment of hereditary angioedema with vapor-heated C1 inhibitor concentrate. *NEJM* 1996;334:1630–4.
128. Legendre CM, Licht C, Muus P, Greenbaum LA, Babu S, Bedrosian C, et al. Terminal complement inhibitor eculizumab in atypical hemolytic-uremic syndrome. *N Engl J Med* 2013;368:2169–81.
155. Fijen CA, Kuijper EJ, te Bulte MT, Daha MR, Dankert J. Assessment of complement deficiency in patients with meningococcal disease in The Netherlands. *Clin Infect Dis* 1999;28:98–105.



## REFERENCES

1. Figueroa JE, Densen P. Infectious diseases associated with complement deficiencies. *Clin Microbiol Rev* 1991;4:359–95.
2. Ross SC, Densen P. Complement deficiency states and infection: epidemiology, pathogenesis and consequences of neisserial and other infections in an immune deficiency. *Medicine* 1984;63:243–73.
3. Singer L, Colten HR, Wetsel RA. Complement C3 deficiency: human, animal, and experimental models. *Pathobiology* 1994;62:14–28.
4. Ram S, Lewis LA, Rice PA. Infections of people with complement deficiencies and patients who have undergone splenectomy. *Clin Microbiol Rev* 2010;23:740–80.
5. Leggiadro RJ, Winkelstein JA. Prevalence of complement deficiencies in children with systemic meningococcal infections. *Pediatr Infect Dis* 1987;6:75–9.
6. Merino J, Rodriguez-Valverde V, Lamelas JA. Prevalence of deficits of complement components in patients with recurrent meningococcal infections. *J Infect Dis* 1983;148:331–6.
7. Ellison RT, Kohler PH, Curd JG, Judson FN, Reller LB. Prevalence of congenital and acquired complement deficiency in patients with sporadic meningococcal disease. *NEJM* 1983;308:913–16.
8. Owen EP, Leisegang F, Whitelaw A, Simpson J, Baker S, Wurznner R, et al. Complement component C5 and C6 mutation screening indicated in meningococcal disease in South Africa. *S Afr Med J* 2012;102:525–7.
9. Nielsen HE, Koch C, Magnussen P, Lind I. Complement deficiencies in selected groups of patients with meningococcal disease. *Scand J Infect Dis* 1989;21:389–44.
10. Nielsen HE, Koch C, Mansa B, Magnussen P, Bergmann OJ. Complement and immunoglobulin studies in 15 cases of chronic meningococcemia: properdin deficiency and hypoinmunoglobulinemia. *Scand J Infect Dis* 1990;22:31–6.
11. Fijen CA, Juijper EJ, Hannema AJ, Sjöhom AG, Van Putten JPM. Complement deficiencies in patients over ten years old with meningococcal disease due to uncommon serogroups. *Lancet* 1989;ii:585–8.
12. Fijen CA, Kujiper EJ, Dankert J, Daha MR, Caugant DA. Characterization of *Neisseria meningitidis* strains causing disease in complement-deficient and complement-sufficient patients. *J Clin Microbiol* 1998;36:2342–5.
13. Ohkuro M, Ogura-Masaki M, Kobayashi K, Sakai M, Takahashi K, Nagasawa S. Effect of iC3b binding to immune complexes upon the phagocytic response of human neutrophils: synergistic functions between Fc gamma R and CR3. *FEBS Lett* 1995;373:189–92.
14. Mantovani B, Rabinovitch M, Nussenzweig V. Phagocytosis of immune complexes by macrophages. Different roles of the macrophage receptor sites for complement (C3) and for immunoglobulin (IgG). *J Exp Med* 1972;135:780–92.
15. Schifferli JA, Bartolotti SR, Peters DK. Inhibition of immune precipitation by complement. *Clin Exp Immunol* 1980;42:387–41.
16. Ng YC, Schifferli JA, Walport MJ. Immune complexes and erythrocyte CR1 (complement receptor type 1): effect of CR1 numbers on binding and release reactions. *Clin Exp Immunol* 1988;71:481–5.
17. Cornacoff JB, Hebert LA, Smead WL, VanAman ME, Birmingham DJ, Waxman FJ. Primate erythrocyte immune complex clearing mechanism. *J Clin Invest* 1983;71:236–40.
18. Botto M, Dell'agnola C, Bygrave AE, Thompson EM, Cook HT, Petry F, et al. Homozygous C1q deficiency causes glomerulonephritis associated with multiple apoptotic bodies. *Nat Genet* 1998;19:56–9.
19. Mevorach D, Mascarenhas JO, Gershov D, Elkou KB. Complement-dependent clearance of apoptotic cells by human macrophages. *J Exp Med* 1998;188:2313–20.
20. Casciola-Rosen LA, Anhalt G, Rosen A. Autoantigens targeted in systemic lupus erythematosus are clustered in two populations of surface structures on apoptotic keratinocytes. *J Exp Med* 1994;179:1317–30.
21. Chatterjee P, Agyemang AF, Alimzhanov MB, Degen S, Tsiftoglou SA, Alicot E, et al. Complement C4 maintains peripheral B-cell tolerance in a myeloid cell dependent manner. *Eur J Immunol* 2013;43:2441–50.
22. Meyer O, Hauptmann G, Tappeiner G, Ochs HD, Mascart-Lemone F. Genetic deficiency of C4, C2, or C1q and lupus syndromes. Association with anti-Ro (SS-A) antibodies. *Clin Exp Immunol* 1985;62:678–82.
23. Provost TT, Arnett FC, Reichlin M. Homozygous C2 deficiency, lupus erythematosus, and anti-Ro (SSA) antibodies. *Arthritis Rheum* 1983;26:1279–84.
24. Hauptmann G, Tappeiner G, Schifferli JA. Inherited deficiency of the fourth component of human complement. *Immunodef Rev* 1988;3–22.
25. Bowness P, Davies KA, Norsworthy PJ, Athanassiou P, Taylor-Wiedeman J, Borysiewicz LK, et al. Hereditary C1q deficiency and systemic lupus erythematosus. *QJM* 1994;87:455–64.
26. Kavanagh D, Goodship T. Genetics and complement in atypical HUS. *Pediatr Nephrol* 2010;25:2431–42.
27. Bresin E, Rurai E, Caprioli J, Sanchez-Corral P, Fremaux-Bacchi V, Rodriguez de Cordoba S, et al. Combined complement gene mutations in atypical hemolytic uremic syndrome influence clinical phenotype. *J Am Soc Nephrol* 2013;24:475–86.
28. Noris M, Remuzzi G. Atypical hemolytic-uremic syndrome. *N Engl J Med* 2009;361:1676–87.
29. Pangburn MK. Cutting edge: localization of the host recognition functions of complement factor H at the carboxyl-terminal: implications for hemolytic uremic syndrome. *J Immunol* 2002;169:4702–6.
30. Klein RJ, Zeiss C, Chew EY, Tsai JY, Sackler RS, Haynes C, et al. Complement factor H polymorphism in age-related macular degeneration. *Science* 2005;308:385–9.
31. Bu F, Maga T, Meyer NC, Wang K, Thomas CP, Nester CM, et al. Comprehensive genetic analysis of complement and coagulation genes in atypical hemolytic uremic syndrome. *J Am Soc Nephrol* 2014;25:55–64.
32. Sellar GC, Blake DJ, Reid KBM. Characterization and organization of the genes encoding the A-, B- and C-chains of the human complement subcomponent C1q. *Biochem J* 1991;274:481–90.
33. Navratil JS, Ahearn JM. Apoptosis and autoimmunity: complement deficiency and systemic lupus erythematosus revisited. *Curr Rheumatol Rep* 2000;2:32–8.
34. Berkel AI, Birben E, Oner C, Oner R, Loos M, Petry F. Molecular, genetic and epidemiologic studies on selective complete C1q deficiency in Turkey. *Immunobiology* 2000;201:347–55.
35. Petry F, Berkel AI, Loos M. Repeated identification of a nonsense mutation in the C1qA-gene of deficient patients in South-East Europe. *Mol Immunol* 1996;33(Suppl. 1):9.
36. Petry F, Berkel AI, Loos M. Multiple identification of a particular type of hereditary C1q deficiency in the Turkish population: review of the cases and additional and functional analysis. *Hum Genet* 1997;100:51–6.
37. Petry F, Hauptmann G, Goetz J, Grosshans E, Loos M. Molecular basis of a new type of C1q-deficiency associated with a non-functional low molecular weight (LMW) C1q: parallels and differences to other known genetic C1q defects. *Immunopharmacology* 1997;38:189–201.
38. Loos M, Colomb M. C1, the first component of complement: structure-function-relationship of C1q and collectins (MBP, SP-A, SP-D, conglutinin), C1-esterases (C1r and C1s), and C1-inhibitor in health and disease. *Behring Inst Mitt* 1993;93:1–5.
39. Ornstein BW, Atkinson JP, Densen P. The complement system in pediatric systemic lupus erythematosus, atypical hemolytic uremic syndrome, and complementic membranogluropathies. *Curr Opin Rheumatol* 2012;24:522–9.
40. Arkwright PD, Riley P, Hughes SM, Alachkar H, Wynn RF. Successful cure of C1q deficiency in human subjects treated with hematopoietic stem cell transplantation. *J Allergy Clin Immunol* 2014;133:265–7.
41. Sturfelt G, Truedsson L, Johansen P, Jonsson H, Nived O, Sjöholm AG. Homozygous C4A deficiency in systemic lupus erythematosus: analysis of patients from a defined population. *Clin Genet* 1990;38:427–33.
42. Mascart-Lemone F, Hauptmann G, Goetz J, Duchateau J, Delespesse G, Vray B, et al. Genetic deficiency of C4 presenting with recurrent infections and a SLE-like disease. Genetic and immunologic studies. *Am J Med* 1983;75:295–304.
43. Kemp ME, Atkinson JP, Skanes VM, Levine RP, Chaplin D. Deletion of C4A genes in patients with systemic lupus erythematosus. *Arthritis Rheum* 1987;30:1015–22.
44. Barba G, Rittner C, Schneider PM. Genetic basis of human complement C4A deficiency. *J Clin Invest* 1993;91:1681–6.
45. Braun L, Schneider PM, Carroll MC, Alper CA, Rittner C, Whitehead AS, et al. Null alleles of human complement C4. Evidence for pseudogenes at the C4A locus and gene conversion at the C4B locus. *J Exp Med* 1990;171:129–40.
46. Kim JH, Jung SH, Bae JS, Lee HS, Yim SH, Park SY, et al. Deletion variants of RABGAP1L, 10q21.3, and C4 are associated with the risk of systemic lupus erythematosus in Korean women. *Arthritis Rheum* 2013;65:1055–63.
47. Howard PF, Hochberg MC, Bias WB, Arnett FC, McLean RH. Relationship between C4 null genes, HLA-D region antigens, and genetic susceptibility to systemic lupus erythematosus in caucasian and black Americans. *Am J Med* 1986;81:187–93.

48. Fiedler AHL, Walport MJ, Batchelor JR, Rynes RI, Black CM, Dodi IA, et al. Family study of the major histocompatibility complex in patients with systemic lupus erythematosus: importance of null alleles of C4A and C4B in determining disease susceptibility. *Br Med J* 1983;286:425-8.
49. Christiansen FT, Zhang WJ, Griffiths M, Mallal SA, Dawkins RL. Major histocompatibility complex (MHC) complement deficiency, ancestral haplotypes and systemic lupus erythematosus (SLE): C4 deficiency explains some but not all of the influence of the MHC. *J Rheumatol* 1991;18:1350-8.
50. Welch TR, Brickman C, Bishof N, Maringhini S, Rutkowski M, Frenze M, et al. The phenotype of SLE associated with complete deficiency of complement isotype C4A. *J Clin Immunol* 1998;18:48-51.
51. Petri M, Watson R, Winkelstein JA, McLean RH. Clinical expression of systemic lupus erythematosus in patients with C4A deficiency. *Medicine* 1993;72:236-44.
52. Biskof NA, Welch TR, Beischel LS. C4B deficiency: a risk factor for bacteremia with encapsulated organisms. *J Infect Dis* 1990;162:248-54.
53. Rowe PC, McLean RH, Wood RA, Leggiadro RJ, Winkelstein JA. Association of C4B deficiency with bacterial meningitis. *J Infect Dis* 1989;160:448-51.
54. Ruddy S. Component deficiencies: the second component. *Prog Allergy* 1986;39:250-60.
55. Johnson CA, Densen P, Hurford RK Jr, Colten HR, Wetsel RA. Type I human complement C2 deficiency. *J Biol Chem* 1992;267:9347-53.
56. Sullivan KE, Petri MA, Schmeckpeper BJ, McLean RH, Winkelstein JA. The prevalence of a mutation which causes C2 deficiency in SLE. *J Rheumatol* 1994;21:1128-33.
57. Truedsson L, Alper CA, Awdeh ZL, Johansen P, Sjöholm AG, Sturfelt G. Characterization of type I complement C2 deficiency MHC haplotypes. *J Immunol* 1993;151:5856-63.
58. Jonsson G, Sjöholm AG, Truedsson L, Bengtsson AA, Braconier JH, Sturfelt G. Rheumatological manifestations, organ damage and autoimmunity in hereditary C2 deficiency. *Rheumatology (Oxford)* 2007;46:1133-9.
59. Jonsson G, Truedsson L, Sturfelt G, Oxelius VA, Braconier JH, Sjöholm AG. Hereditary C2 deficiency in Sweden: frequent occurrence of invasive infection, atherosclerosis, and rheumatic disease. *Medicine (Baltimore)* 2005;84:23-34.
60. Botto M, Fong KY, So AK, Rudge A, Walport MJ. Molecular basis of hereditary C3 deficiency. *J Clin Invest* 1990;86:1158-63.
61. Botto M, Lissandrini D, Sorio C, Walport M. Biosynthesis and secretion of complement component (C3) by activated human polymorphonuclear leukocytes. *J Immunol* 1992;149:1348-55.
62. Reie ES, Falcao DA, Isaac L. Clinical aspects and molecular basis of primary deficiencies of complement component C3 and its regulatory proteins factor I and factor H. *Scand J Immunol* 2006;63:155-68.
63. Wurzner R, Hobart MJ, Fernie BA, Mewar D, Potter PC, Orren P, et al. Molecular basis of subtotal complement C6 deficiency. *J Clin Invest* 1995;95:1877-83.
64. Nishizaka H, Horiuchi T, Zhu Z-B, Fukumori Y, Nagasawa K, Hayashi K, et al. Molecular bases for inherited human complement component C6 deficiency in two unrelated individuals. *J Immunol* 1996;156:2309-15.
65. Zhu ZB, Totemchokchyakarn K, Atkinson TP, Whiteley RJ, Volanakis JE. Molecular defects leading to human complement component C6 deficiency. *FASEB J* 1996;10:A1446.
66. Hobart MJ, Fernie BA, Fijen KA, Orren A. The molecular basis of C6 deficiency in the western Cape, South Africa. *Hum Genet* 1998;103:506-12.
67. Zhu Z, Atkinson TP, Hovanky KT, Boppana SB, Dai YL, Densen P, et al. High prevalence of complement component C6 deficiency among African-Americans in the south-eastern USA. *Clin Exp Immunol* 2000;119:305-10.
68. Rameix-Welti MA, Regnier CH, Bienaime F, Blouin J, Schifferli J, Fridman WH, et al. Hereditary complement C7 deficiency in nine families: subtotal C7 deficiency revisited. *Eur J Immunol* 2007;37:1377-85.
69. Tedesco F, Roncelli L, Petersen BH, Agnello V, Sodet JM. Two distinct abnormalities in patients with C8 alpha-gamma deficiency. Low level of C8 beta chain and presence of dysfunctional C8 alpha-gamma subunit. *J Clin Invest* 1990;86:884-8.
70. Kojima T, Horiuchi T, Nishizaka H, Fukumori Y, Amano T, Nagasawa K, et al. Genetic basis of human complement C8 alpha-gamma deficiency. *J Immunol* 1998;161:3762-6.
71. Kaufmann T, Hansch G, Rittner C, Spath P, Tedesco F, Schneider PM. Genetic basis of human complement C8 beta deficiency. *J Immunol* 1993;150:4943-7.
72. Densen P, Ackerman L, Saucedo L, Figueroa J, Si Z-H, Stoltzfus CM. The genetic basis of C8a-g deficiency. *Mol Immunol* 1996;33(Suppl. 1):68.
73. Kira R, Ihara K, Takada H, Gondo K, Hara T. Nonsense mutation in exon 4 of human complement C9 gene is the major cause of Japanese complement C9 deficiency. *Hum Genet* 1998;102:605-10.
74. Kira R, Ihara K, Watanabe K, Kanemitsu S, Ahmed SU, Gondo K, et al. Molecular epidemiology of C9 deficiency heterozygotes with an Arg95Stop mutation of the C9 gene in Japan. *J Hum Genet* 1999;44:109-11.
75. Inai S, Kitamura H, Hiramatsu S, Nagaki K. Deficiency of the ninth component of complement in man. *J Clin Lab Immunol* 1979;2:85-90.
76. Witzel-Schlomp K, Hobart MJ, Fernie BA, Orren A, Wurzner R, Rittner C, et al. Heterogeneity in the genetic basis of human complement C9 deficiency. *Immunogenetics* 1998;48:144-7.
77. Kang HJ, Kim HS, Lee YK, Cho HC. High incidence of complement C9 deficiency in Koreans. *Ann Clin Lab Sci* 2005;35:144-8.
78. Horiuchi T, Nishizaka H, Kojima T, Sawabe T, Niho Y, Schneider PM, et al. A non-sense mutation at Arg95 is predominant in complement 9 deficiency in Japanese. *J Immunol* 1998;160:1509-13.
79. Lint TF, Zeitz HJ, Gewurz H. Inherited deficiency of the ninth component of complement in man. *J Immunol* 1980;125:2252-8.
80. Nagata M, Hara T, Aoki T, Mizuno Y, Akeda H, Inaba S, et al. Inherited deficiency of the ninth component of complement: an increased risk of meningococcal meningitis. *J Pediatr* 1989;114:260-5.
81. Thiel S, Frederiksen PD, Jensenius JC. Clinical manifestations of mannan-binding lectin deficiency. *Mol Immunol* 2006;43:86-96.
82. Thiel S, Steffensen R, Christensen IJ, Ip WK, Lau YL, Reason IJ, et al. Deficiency of mannan-binding lectin associated serine protease-2 due to missense polymorphisms. *Genes Immun* 2007;8:154-63.
83. Garcia-Laorden MI, Garcia-Saavedra A, de Castro FR, Violan JS, Rajas O, Blanquer J, et al. Low clinical penetrance of mannose-binding lectin-associated serine protease 2 deficiency. *J Allergy Clin Immunol* 2006;118:1383-6.
84. Garcia-Laorden MI, Sole-Violan J, Rodriguez de Castro F, Aspa J, Briones ML, Garcia-Saavedra A, et al. Mannose-binding lectin and mannose-binding lectin-associated serine protease 2 in susceptibility, severity, and outcome of pneumonia in adults. *J Allergy Clin Immunol* 2008;122:368-74, 74 e1-e2.
85. Stengaard-Pedersen K, Thiel S, Gadjeva M, Moller-Kristensen M, Sorensen R, Jensen LT, et al. Inherited deficiency of mannan-binding lectin-associated serine protease 2. *N Engl J Med* 2003;349:554-60.
86. Cicardi M, Bergamaschini L, Cugno M, Beretta A, Zingale LC, Colombo M, et al. Pathogenetic and clinical aspects of C1 inhibitor deficiency. *Immunobiology* 1998;199:366-76.
87. Frank MM, Gelfand JA, Atkinson JP. Hereditary angioedema: the clinical syndrome and its management. *Ann Intern Med* 1976;84:580-91.
88. Cugno M, Zanichelli A, Foienni F, Caccia S, Cicardi M. C1-inhibitor deficiency and angioedema: molecular mechanisms and clinical progress. *Trends Mol Med* 2009;15:69-78.
89. Agostoni A, Aygoren-Pursun E, Binkley KE, Blanch A, Bork K, Bouillet L, et al. Hereditary and acquired angioedema: problems and progress: proceedings of the third C1 esterase inhibitor deficiency workshop and beyond. *J Allergy Clin Immunol* 2004;114(3 Suppl.):S51-131.
90. Schapira M, Silver LD, Scott CF, Schmaier AH, Prograis LJ Jr, Curd JG, et al. Prekallikrein activation and high-molecular-weight kininogen consumption in hereditary angioedema. *N Engl J Med* 1983;308:1050-3.
91. Curd JG, Prograis LJ Jr, Cochrane CG. Detection of active kallikrein in induced blister fluids of hereditary angioedema patients. *J Exp Med* 1980;152:742-8.
92. Klemperer MR, Donaldson VH, Rosen FS. Effect of C1 esterase on vascular permeability in man: studies on normal and complement deficient individuals and in patients with hereditary angioneurotic edema. *J Clin Invest* 1968;47:604-10.
93. Cugno M, Nussberger J, Cicardi M, Agostoni A. Bradykinin and the pathophysiology of angioedema. *Int Immunopharmacol* 2003;3:311-17.
94. Sheffer AL, Craig JM, Willms-Kretschmer K, Austen KE, Rosen FS. Histopathological and ultrastructural observations on tissues from patients with hereditary angioneurotic edema. *J Allergy* 1971;47:292-7.
95. Carugati A, Pappalardo E, Zingale LC, Cicardi M. C1-inhibitor deficiency and angioedema. *Mol Immunol* 2001;38:161-73.
96. Zuraw BL. Diagnosis and management of hereditary angioedema: an American approach. *Transfus Apher Sci* 2003;29:239-45.
97. Zuraw BL. Clinical practice. Hereditary angioedema. *N Engl J Med* 2008;359:1027-36.
98. Nielsen HE, Christensen KC, Koch C, Thomsen BS, Heegaard NH, Tranum-Jensen J. Hereditary, complete deficiency of complement factor

- H associated with recurrent meningococcal disease. *Scand J Immunol* 1989;30:711–18.
99. Sanchez-Corral P, Perez-Caballero D, Huarte O, Simckes AM, Goicoechea E, Lopez-Trascasa M, et al. Structural and functional characterization of factor H mutations associated with atypical hemolytic uremic syndrome. *Am J Hum Genet* 2002;71:1285–95.
  100. Bitzan M. Treatment options for HUS secondary to *Escherichia coli* O157:H7. *Kidney Int Suppl* 2009;112:S62–6.
  101. Caprioli J, Peng L, Remuzzi G. The hemolytic uremic syndromes. *Curr Opin Crit Care* 2005;11:487–92.
  102. Haines JL, Hauser MA, Schmidt S, Scott WK, Olson LM, Gallins P, et al. Complement factor H variant increases the risk of age-related macular degeneration. *Science* 2005;308:419–21.
  103. Vyse TJ, Spath PJ, Davies KA, Morley BJ, Philippe P, Athanassiou P, et al. Hereditary complement factor I deficiency. *QJM* 1994;87:385–401.
  104. Abramson N, Alper CA, Lachmann PJ, Rosen FS, Jandl JH. Deficiency of C3 inactivator in man. *J Immunol* 1971;107:19–25.
  105. Fremeaux-Bacchi V, Dragon-Durey MA, Blouin J, Vigneau C, Kuypers D, Boudailliez B, et al. Complement factor I: a susceptibility gene for atypical haemolytic uraemic syndrome. *J Med Genet* 2004;41:e84.
  106. Kavanagh D, Goodship TH. Membrane cofactor protein and factor I: mutations and transplantation. *Semin Thromb Hemost* 2006;32:155–9.
  107. Kavanagh D, Kemp EJ, Mayland E, Winney RJ, Duffield JS, Warwick G, et al. Mutations in complement factor I predispose to development of atypical hemolytic uremic syndrome. *J Am Soc Nephrol* 2005;16:2150–5.
  108. Caprioli J, Noris M, Brioschi S, Pianetti G, Castelletti F, Bettinaglio P, et al. Genetics of HUS: the impact of MCP, CFH, and IF mutations on clinical presentation, response to treatment, and outcome. *Blood* 2006;108:1267–79.
  109. Richards A, Kemp EJ, Liszewski MK, Goodship JA, Lampe AK, Decorte R, et al. Mutations in human complement regulator, membrane cofactor protein (CD46), predispose to development of familial hemolytic uremic syndrome. *Proc Natl Acad Sci U S A* 2003;100:12966–71.
  110. Zimmerhackl LB, Besbas N, Jungraithmayr T, van de Kar N, Karch H, Karpman D, et al. Epidemiology, clinical presentation, and pathophysiology of atypical and recurrent hemolytic uremic syndrome. *Semin Thromb Hemost* 2006;32:113–20.
  111. Fijen CA, van den Bogaard R, Schipper M, Mannens M, Schlesinger M, Nordin FG, et al. Properdin deficiency: molecular basis and disease association. *Mol Immunol* 1999;36:863–7.
  112. Kluin-Nelemans H, van Velzen-Blad H, van Helden HPT, Daha MR. Functional deficiency of complement factor D in a monozygous twin. *Clin Exp Immunol* 1984;58:724–30.
  113. Carroll MC. The complement system in regulation of adaptive immunity. *Nat Immunol* 2004;5:981–6.
  114. Biselli R, Casapolo I, D'Amelio R, Salvato S, Matricardi PM, Brai M. Antibody response to meningococcal polysaccharides A and C in patients with complement defects. *Scand J Immunol* 1993;37:644–50.
  115. Platonov AE, Beloborodov VB, Pavlova LI, Ver-shinina IV, Kayhty H. Vaccination of patients deficient in a late complement component with tetravalent meningococcal capsular polysaccharide vaccine. *Clin Exp Immunol* 1995;100:32–9.
  116. Borrow R, Joseph H, Andrews N, Acuna M, Longworth E, Martin S, et al. Reduced antibody response to revaccination with meningococcal serogroup A polysaccharide vaccine in adults. *Vaccine* 2000;19:1129–32.
  117. MacLennan J, Obaro S, Deeks J, Williams D, Pais L, Carlone G, et al. Immune response to revaccination with meningococcal A and C polysaccharides in Gambian children following repeated immunisation during early childhood. *Vaccine* 1999;17:3086–93.
  118. Bowen T, Cicardi M, Farkas H, Bork K, Kreuz W, Zingale L, et al. Canadian 2003 international consensus algorithm for the diagnosis, therapy, and management of hereditary angioedema. *J Allergy Clin Immunol* 2004;114:629–37.
  119. Church JA. Oxandrolone treatment of childhood hereditary angioedema. *Ann Allergy Asthma Immunol* 2004;92:377–8.
  120. Gelfand JA, Sherins RJ, Alling DW, Frank MM. Treatment of hereditary angioedema with danazol. Reversal of clinical and biochemical abnormalities. *N Engl J Med* 1976;295:1444–8.
  121. Agostoni A, Cicardi M, Cugno M, Storti E. Clinical problems in the C1-inhibitor deficient patient. *Behring Inst Mitt* 1993;93:306–12.
  122. Sheffer AL, Austen KE, Rosen FS. Tranexamic acid therapy in hereditary angioneurotic edema. *NEJM* 1972;287:452–9.
  123. Frank MM, Sergeant JS, Kane MA, Alling DW. Epsilon aminocaproic acid therapy of hereditary angioneurotic edema: a double blind study. *NEJM* 1972;286:808–12.
  124. Waytes AT, Rosen FS, Frank MM. Treatment of hereditary angioedema with vapor-heated C1 inhibitor concentrate. *NEJM* 1996;334:1630–4.
  125. Levi M, Choi G, Picavet C, Hack CE. Self-administration of C1-inhibitor concentrate in patients with hereditary or acquired angioedema caused by C1-inhibitor deficiency. *J Allergy Clin Immunol* 2006;117:904–8.
  126. Bork K, Barnstedt SE. Treatment of 193 episodes of laryngeal edema with C1 inhibitor concentrate in patients with hereditary angioedema. *Arch Intern Med* 2001;161:714–18.
  127. Prematta M, Gibbs JG, Pratt EL, Stoughton TR, Craig TJ. Fresh frozen plasma for the treatment of hereditary angioedema. *Ann Allergy Asthma Immunol* 2007;98:383–8.
  128. Legendre CM, Licht C, Muus P, Greenbaum LA, Babu S, Bedrosian C, et al. Terminal complement inhibitor eculizumab in atypical hemolytic-uremic syndrome. *N Engl J Med* 2013;368:2169–81.
  129. Johnston RB Jr, Altenburger KM, Atkinson AW Jr, Curry RH. Complement in the newborn infant. *Pediatrics* 1979;64(5 Pt 2 Suppl.):781–6.
  130. Adinolfi M, Lehner T. C9 and Factor B as acute phase proteins and their diagnostic and prognostic value in disease. *Exp Clin Immunogenet* 1988;5:123–32.
  131. Ballou M, Fang F, Good RA, Day NK. Developmental aspects of complement components in the newborn. The presence of complement components and C3 proactivator (properdin factor B) in human colostrum. *Clin Exp Immunol* 1974;18:257–66.
  132. Gitlin D, Biasucci A. Development of gamma G, gamma A, gamma M, beta IC-beta IA, C 1 esterase inhibitor, ceruloplasmin, transferrin, hemopexin, haptoglobin, fibrinogen, plasminogen, alpha 1-antitrypsin, orosomucoid, beta-lipoprotein, alpha 2-macroglobulin, and prealbumin in the human conceptus. *J Clin Invest* 1969;48:1433–46.
  133. Sawyer MK, Forman ML, Kuplic LS, Stiehm ER. Developmental aspects of the human complement system. *Biol Neonate* 1971;19:148–62.
  134. McLean RH, Forsgren A, Bjorksten B, Kim Y, Quie PG, Michael AF. Decreased serum factor B concentration associated with decreased opsonization of *Escherichia coli* in the idiopathic nephrotic syndrome. *Pediatr Res* 1977;11:910–16.
  135. Swaak AJG, Aarden LA, Statius van Eps LW, Feltkamp TEW. Anti-dsDNA and complement profiles as prognostic guides in systemic lupus erythematosus. *Arthritis Rheum* 1979;22:226–35.
  136. Buyon JP, Tamerius J, Belmont HM, Abramson SB. Assessment of disease activity and impending flare in patients with systemic lupus erythematosus. Comparison of the use of complement split products and conventional measurements of complement. *Arthritis Rheum* 1992;35:1028–36.
  137. Buyon JP, Tamerius J, Ordorica S, Young B, Abramson SB. Activation of the alternative complement pathway accompanies disease flares in systemic lupus erythematosus during pregnancy. *Arthritis Rheum* 1992;35:55–61.
  138. Sullivan KE, Wisnieski JJ, Winkelstein JA, Louie J, Sachs E, Choi R, et al. Serum complement determinations in patients with quiescent systemic lupus erythematosus. *J Rheumatol* 1996;23:2063–7.
  139. Heckbert SR, Stryker WS, Coltin KL, Manson JE, Platt R. Serum sickness in children after antibiotic exposure: estimates of occurrence and morbidity in a health maintenance organization population. *Am J Epidemiol* 1990;132:336–42.
  140. Parshuram CS, Phillips RJ. Retrospective review of antibiotic-associated serum sickness in children presenting to a paediatric emergency department. *Med J Aust* 1998;169:116.
  141. Border WA, Noble NA. From serum sickness to cytokines: advances in understanding the molecular pathogenesis of kidney disease. *Lab Invest* 1993;68:125–8.
  142. Bielory L, Gascon P, Lawley TJ, Young NS, Frank MM. Human serum sickness: a prospective analysis of 35 patients treated with equine anti-thymocyte globulin for bone marrow failure. *Medicine (Baltimore)* 1988;67:40–57.
  143. Bielory L, Gascon P, Lawley TJ, Nienhuis A, Frank MM, Young NS. Serum sickness and haematopoietic recovery with antithymocyte globulin in bone marrow failure patients. *Br J Haematol* 1986;63:729–36.
  144. Sprung CL, Schultz DR, Marcial E, Caralis PV, Gelbard MA, Arnold PI, et al. Complement activation in septic shock patients. *Crit Care Med* 1986;14:525–8.
  145. Ellison RT 3rd, Horsburgh CR Jr, Curd J. Complement levels in patients with hepatic dysfunction. *Dig Dis Sci* 1990;35:231–5.
  146. Homann C, Varming K, Hogasen K, Molines TE, Graudal N, Thomsen AC, et al. Acquired

- C3 deficiency in patients with alcoholic cirrhosis predisposes to infection and increased mortality. *Gut* 1997;40:544–9.
147. Amadori A, Candi P, Sasdelli M, Massai G, Favilla S, Passaleva A, et al. Hemodialysis leukopenia and complement function with different dialyzers. *Kidney Int* 1983;24:775–81.
  148. Sakamoto M, Fujisawa Y, Nishioka K. Physiologic role of the complement system in host defense, disease, and malnutrition. *Nutrition* 1998;14:391–8.
  149. Mishra OP, Agrawal S, Usha, Ali Z, Das BK, Singh TB. Levels of immunoglobulins and complement C3 in protein-energy malnutrition. *J Trop Pediatr* 1999;45:179–81.
  150. Shichishima T. Glycosylphosphatidylinositol (GPI)-anchored membrane proteins in clinical pathophysiology of paroxysmal nocturnal hemoglobinuria (PNH). *Fukushima J Med Sci* 1995;41:1–13.
  151. Shichishima T, Noji H. Heterogeneity in the molecular pathogenesis of paroxysmal nocturnal hemoglobinuria (PNH) syndromes and expansion mechanism of a PNH clone. *Int J Hematol* 2006;84:97–103.
  152. Yamashina M, Ueda E, Kinoshita T, Takami T, Ojima A, Ono H, et al. Inherited complete deficiency of 20-kilodalton homologous restriction factor (CD59) as a cause of paroxysmal nocturnal hemoglobinuria. *NEJM* 1990;323:1184–9.
  153. Ekdahl K, Truedsson L, Sjöholm AG, Braconier JH. Complement analysis in adult patients with a history of bacteremic pneumococcal infections or recurrent pneumonia. *Scand J Infect Dis* 1995;27:111–17.
  154. Ernst T, Spath PJ, Aebi C, Schaad UB, Bianchetti MG. Screening for complement deficiency in bacterial meningitis. *Acta Paediatr* 1997;86:1009–10.
  155. Fijen CA, Kuijper EJ, te Bulte MT, Daha MR, Dankert J. Assessment of complement deficiency in patients with meningococcal disease in The Netherlands. *Clin Infect Dis* 1999;28:98–105.
  156. Cremer R, Wahn V. Deficiency of late complement components in patients with severe and recurrent meningococcal infections. *Eur J Pediatr* 1996;155:723–4.



# Defects of Innate Immunity

SERGIO D. ROSENZWEIG | STEVEN M. HOLLAND

## KEY POINTS

- White blood cells (lymphoid or myeloid) can suffer from quantitative or functional congenital disorders.
- The type of cells or mechanisms that are mainly affected will define the spectrum of infectious diseases a particular patient will suffer.
- The pathophysiology, clinical manifestations and approaches to diagnosis of classic innate immunity defects (e.g. neutropenias, CGD, LAD and mucocutaneous candidiasis among other syndromes) are discussed.
- Recently recognized genetic diseases (e.g. IRF8, ISG15 and some forms of mucocutaneous candidiasis) are presented.

This chapter focuses on neutrophils and monocytes, and disorders that arise from their quantitative or functional defects. Mature neutrophils develop in the bone marrow from a myeloid stem cell over 14 days, during which time proliferation, differentiation and maturation occur. Mature neutrophils, with their load of primary, secondary and tertiary granules, are released into the bloodstream where they stay 6 to 10 hours before exiting by diapedesis. In tissues, these cells work in ways that are primarily phagocytic, bactericidal, fungicidal or in the removal of damaged tissue. Neutrophil disorders can be divided into quantitative (increase or decrease) and functional (failures in specific metabolic or interactive pathways). Quantitative disorders include neutrophilia (>7,000 neutrophils per microliter in adult patients) and neutropenia (mild: <1,500 neutrophils per microliter, moderate: 500–1,000 neutrophils per microliter, severe: <500 neutrophils per microliter). With very few exceptions (e.g. chronic idiopathic neutrophilia, leukocyte adhesion deficiencies, myeloproliferative diseases) neutrophilia is dependent on causes extrinsic to the neutrophils (e.g. acute or chronic infection, steroids, epinephrine). On the other hand, the causes of neutropenia are multiple and can be intrinsic or extrinsic to neutrophils or their progenitors (Box 11-1). Neutropenia usually falls into categories of decreased production or increased destruction, or a combination of the two.

Qualitative myeloid disorders include defects in motility (adhesion, chemotaxis), defects in phagocytosis, defects of granule synthesis and release, and defects in killing (see Box 11-1).

A neutrophil disorder should be suspected in patients with recurrent, severe, bacterial or fungal infections, especially those caused by unusual organisms (e.g. *Chromobacterium violaceum*)

or in uncommon locations (e.g. liver abscess; Table 11-1). Viral and parasitic infections are not increased in these patients.

Initial laboratory evaluation should take into account the clinical presentation to direct where the defect is likely to be. Some assays, such as repeated white blood cell (WBC) counts with differentials or microscopic evaluation of neutrophils, are relatively simple and can readily exclude neutropenia or some granule defects. Flow cytometry requires a careful consideration of which markers to examine. Functional assays, such as oxidative burst testing, phagocytosis or chemotaxis, are the most challenging because few laboratories perform them routinely (Table 11-2). We will consider some of the clinical, diagnostic and management aspects of a few of the best characterized myeloid disorders.

## Severe Congenital Neutropenia

Severe congenital neutropenia (SCN) comprises a heterogeneous group of disorders that share the common characteristics of bone marrow granulocytic maturation arrest at the promyelocyte or myelocyte stage, severe chronic neutropenia (fewer than 200 neutrophils per microliter) and increased susceptibility to acute myeloid leukemia.<sup>1,2</sup>

In 1956 Kostmann described a Swedish kindred with severe congenital neutropenia inherited in an autosomal recessive pattern.<sup>3</sup> Klein and colleagues identified homozygous mutations in the antiapoptotic molecule HAX1 in patients with autosomal recessive SCN, which was confirmed to be the cause in the original Kostmann pedigree as well.<sup>4</sup> Some patients with HAX1 deficiency also suffer from cognitive problems and/or epilepsy.<sup>5</sup>

Among patients with SCN, single allele mutations in the G-CSF receptor (GCSFR, 1p35-p34.3) have been associated with the development of acute myeloid leukemia.<sup>6</sup> However, not all patients with SCN develop mutations in the G-CSF receptor, indicating that these mutations are somatic mutation epiphenomena that occur in the setting of SCN but do not cause it.<sup>7</sup> Autosomal recessive mutations in the glucose-6-phosphatase catalytic subunit 3 (G6PC3) also cause congenital neutropenia along with cardiac and urogenital malformations.<sup>8</sup>

Horwitz and colleagues<sup>9</sup> and Dale and colleagues<sup>10</sup> found that 22 of 25 patients with dominant or spontaneous SCN had heterozygous mutations in the gene encoding neutrophil elastase (*ELA2*). Interestingly, mutations in this gene are also responsible for cyclic neutropenia. *ELA2* mutations are responsible for more than 50% of SCN cases in Caucasian patients.<sup>11</sup>

The clinical manifestations of SCN appear promptly after birth: 50% of affected infants are symptomatic within the first month of life, and 90% within the first 6 months; omphalitis, upper and lower respiratory tract infections, and skin and liver

**BOX 11-1 NEUTROPHIL DISORDERS: CAUSES****NEUTROPHILIA**

Usually dependent on causes *extrinsic* to the neutrophils (e.g. acute or chronic infection)

**NEUTROPENIA**

Caused by defects *intrinsic* to the neutrophils or their progenitors (severe congenital neutropenia, cyclic neutropenia, neutropenia associated with other well-defined syndromes [e.g. Schwachman syndrome, Fanconi's syndrome, dyskeratosis congenita, Chédiak-Higashi syndrome, reticular dysgenesis, WHIM syndrome])

Caused by defects *extrinsic* to the neutrophils or their progenitors (infections, drugs, immune mediated, metabolic diseases, nutritional deficiencies, bone marrow infiltration)

**MOTILITY DISORDERS**

Adhesion: Leukocyte adhesion deficiency 1, 2 or 3

Chemotaxis: Leukocyte adhesion deficiency 1, 2 or rac2; localized juvenile periodontitis, neutrophil  $\beta$ -actin deficiency, secondary to extensive burns, secondary to alcohol consumption

**PHAGOCYTOSIS DISORDERS**

Leukocyte adhesion deficiency 1 (complement-mediated only); secondary to antibody deficiencies; complement deficiencies; mannose binding protein deficiency

**DISORDERS OF GRANULE FORMATION AND CONTENT**

Chédiak-Higashi syndrome; specific granule deficiency

**MICROBICIDAL DISORDERS**

Chronic granulomatous disease; myeloperoxidase deficiency; glucose-6-phosphate dehydrogenase deficiency, glutathione pathway deficiencies

abscesses are common. Subcutaneous recombinant granulocyte-colony stimulating factor (G-CSF; 5  $\mu$ g/kg/day) has dramatically changed the prognosis of these patients.<sup>1,2</sup> Since the advent of recombinant G-CSF, reductions in the number of infections and hospitalization days and an increase in life expectancy have been described.<sup>1,2</sup>

Devriendt and colleagues<sup>12</sup> described a family with an X-linked form of severe congenital neutropenia (XLN) caused by mutations in the Wiskott-Aldrich syndrome protein (WASP). In contrast to the WASP mutations that produce classical Wiskott-Aldrich syndrome or X-linked thrombocytopenia, most of which are caused by mutations resulting in reduced WASP transcription or translation, the mutation causing XLN (Leu270Pro) creates a constitutively active mutant protein.

Two families with heterozygous mutations in *GFI1* and congenital neutropenia and monocytosis have been described.<sup>13</sup> *GFI1* mutations act in a dominant-negative way, i.e. inheritance is autosomal dominant. Reticular dysgenesis is an autosomal recessive severe combined immunodeficiency characterized by early myeloid arrest, neutropenia, lymphopenia and sensorineural loss (see Chapter 9).

## Cyclic Neutropenia/ Cyclic Hematopoiesis

Cyclic neutropenia/cyclic hematopoiesis is inherited as an autosomal dominant trait and characterized by regular cyclic fluctuations in all hematopoietic lineages. However, clinical manifestations are almost exclusively associated with variations in neutrophils. Neutrophil counts cycle on average every 21 days

(range 14 to 36 days), including periods of severe neutropenia (<200/ $\mu$ L) that last from 3 to 10 days.<sup>14,15</sup> Mutations in *ELA2* (neutrophil elastase 2, 19p13.3) have been identified in all pedigrees analyzed.<sup>10,11</sup> Most patients have manifestations of neutropenia in early childhood. Oral ulcerations, gingivitis, lymphadenopathy, pharyngitis/tonsillitis and skin lesions are the most frequent findings. Early loss of permanent teeth as a consequence of chronic gingivitis and periapical abscesses is common.<sup>16</sup> Bone marrow aspirates obtained during periods of neutropenia show maturation arrest at the myelocyte stage or bone marrow hypoplasia.<sup>17</sup>

Granulocyte-colony stimulating factor (G-CSF) improves peripheral neutrophil counts and decreases morbidity in cyclic neutropenia patients. Infections and hospitalizations appear to lessen naturally with age.<sup>16</sup>

Large granular lymphocytosis is a cause of adult onset cyclic or sustained neutropenia. This disease is caused by clonal expansion of CD8 T cells or NK cells with a tropism for neutrophils and sometimes other marrow elements. This diagnosis is suspected in an adult with new onset neutropenia and is confirmed by identification of clonal CD8 T cells infiltrating bone marrow, often in lymphoid aggregates.<sup>18</sup>

## Warts, Hypogammaglobulinemia, Infections and Myelokathexis (WHIM) Syndrome

Myelokathexis (from the Greek, meaning 'retained in the bone marrow') is a congenital disorder with severe chronic neutropenia. Unlike other forms of congenital neutropenia, bone marrow aspirates from myelokathexis patients show myeloid hypercellularity with increased numbers of granulocytes at all stages of differentiation. A significant number of patients with myelokathexis also have warts, hypogammaglobulinemia and infections of varying severity. Most WHIM patients have heterozygous deletions affecting the chemokine receptor CXCR4.<sup>19</sup> Enhanced CXCR4 activity delays release of mature neutrophils from the bone marrow, resulting in peripheral neutropenia.<sup>20,21</sup> Recurrent sinopulmonary infections are frequent. Memory B cells are also depressed in this disease, in part accounting for the humoral defects.<sup>22</sup> During episodes of infection, neutrophil counts typically increase compared to baseline levels. Steroids, subcutaneous epinephrine, intravenous endotoxin, as well as G-CSF and GM-CSF, can mobilize mature neutrophils from WHIM bone marrow. Sustained therapy with G-CSF or GM-CSF increases the number of neutrophils in the peripheral blood and decreases the number of infections. Plerixafor (Mozobil®), a small molecule that binds and blocks CXCR4 and is used for hematopoietic stem cell mobilization for transplantation, has also been shown to have a beneficial effect in WHIM patients.<sup>23,24</sup>

## Immune-Mediated Neutropenias

### ALLOIMMUNE NEONATAL NEUTROPENIA

Alloimmune neonatal neutropenia (ANN) is produced by the transplacental transfer of maternal antibodies against NA1 and NA2, two isotypes of the immunoglobulin receptor Fc $\gamma$ RIIb, causing destruction of neonatal neutrophils.<sup>25–29</sup> If the mother does not express Fc $\gamma$ RIIb on her own neutrophils, she may

TABLE 11-1

**Infections and WBC Defects: Features Highly Suspicious of Phagocyte Disorders. (A) Severe Infections, (B) Recurrent Infections, (C) Infections Due to Specific Microorganisms, (D) Unusually Located Infections**

(A) SEVERE INFECTIONS		(B) RECURRENT INFECTIONS		(C) SPECIFIC INFECTIONS		(D) UNUSUALLY LOCATED INFECTIONS	
Type of Infection	Diagnosis to Consider	Site of Infection	Diagnosis to Consider	Microorganism	Diagnosis to Consider	Site of Infection	Diagnosis to Consider
Cellulitis	Neutropenia, LAD, CGD, HIES	Cutaneous	Neutropenia, CGD, LAD, HIES	<i>Staphylococcus epidermidis</i>	Neutropenia, LAD	Umbilical cord stump	LAD
Colitis	Neutropenia, CGD	Gums	LAD, neutropenia, neutrophil motility disorders	<i>Serratia marcescens</i> , <i>C. violaceum</i> , <i>Nocardia</i> , <i>Burkholderia cepacia</i> , <i>Granulibacter bethesdaensis</i>	CGD	Liver abscess	CGD
Osteomyelitis	CGD, MSMD pathway defects	Upper and lower respiratory tract	Neutropenia, HIES, functional neutrophil disorders	<i>Aspergillus</i>	Neutropenia, CGD, HIES	Gums	LAD, neutropenia, neutrophil motility disorders
		GI tract	CGD, MSMD pathway defects (salmonella)	Nontuberculous mycobacteria, BCG	MSMD pathway defects, SCID, CGD		
		Lymph nodes	CGD, MSMD pathway defects (mycobacteria)	<i>Candida</i>	Neutropenia, CGD, MPO, CMC		
		Osteomyelitis	CGD, MSMD pathway defects				

CGD – Chronic granulomatous disease, CMC – chronic mucocutaneous candidiasis, HIES – hyper-IgE syndrome, LAD – leukocyte adhesion deficiency, MPO – myeloperoxidase deficiency, MSMD – Mendelian susceptibility to mycobacterial diseases, SCID – severe combined immunodeficiency.

TABLE 11-2

**Laboratory Evaluation of Patient with Suspected Neutrophil Disorder**

Test	If Normal, It Excludes...
WBC count and differential (repeated)	All forms of neutropenia
Neutrophil morphologic evaluation	Specific granule deficiency, Chédiak-Higashi syndrome
Flow cytometry	
CD18	LAD 1 (complete)
CD15s (sialyl-Lewis <sup>x</sup> )	LAD 2
Dihydrorhodamine (DHR) oxidation	CGD (MPO deficiency, severe G6PD deficiencies and glutathione pathway deficiencies have abnormal DHR oxidation as well)
STAT-1 phosphorylation	Complete IFNGR1, IFNGR2 deficiency
STAT-4 phosphorylation	Complete IL-12Rβ1 and Tyk2 deficiency
Bone marrow aspirate	
Neutrophil maturation	Severe congenital neutropenia, cyclic neutropenia
Neutrophil retention	WHIM syndrome
Nitroblue tetrazolium reduction	CGD (severe G6PD deficiencies and glutathione pathway deficiencies have abnormal NBT reduction as well)

\*Patients should be evaluated considering their familial history, physical examination and associated co-morbid factors.

elaborate antibodies against paternally encoded FcγRIIb expressed on fetal neutrophils. These complement-activating antineutrophil antibodies can be detected in 1 in 500 live births, making the potential incidence of ANN high. This disease should be considered in the evaluation of all infants with neutropenia, with or without infection. Antibody-coated neutrophils in ANN are phagocytosed in the reticuloendothelial system and removed from the circulation, leaving the neonate neutropenic and prone to infections. Omphalitis, cellulitis and pneumonia may be the presenting infections within the first 2 weeks of life. The diagnosis can be made by detection of neutrophil-specific alloantibodies in maternal serum. Parenteral antibiotics (even in the absence of other signs of sepsis) and G-CSF should be included in the initial management of ANN. As expected, ANN tends to improve spontaneously with the waning of maternal antibody levels, but this process may take months.<sup>29</sup>

### PRIMARY AND SECONDARY AUTOIMMUNE NEUTROPENIA

Autoimmune neutropenia (AIN) is a rare disorder, caused by peripheral destruction of neutrophils and/or their precursors by autoantibodies present in patient serum or mediated by large granular lymphocytes (CD3<sup>+</sup>/CD8<sup>+</sup>/CD57<sup>+</sup> T cells) in the bone marrow. Autoimmune neutropenia can be either primary or secondary. When the neutropenia is an isolated clinical entity it

is primary AIN, and when associated with another disease, it is secondary AIN.

### Primary Autoimmune Neutropenia

Primary AIN is the most common cause of chronic neutropenia (absolute neutrophil count  $<1500/\mu\text{L}$  lasting at least 6 months) in infancy and childhood. There is a slight female predominance and it has been reported in about 1:100,000 live births, ten times more frequently than SCN. Antibodies directed against different neutrophil antigens can be detected in almost all patients. Approximately one third of these autoantibodies are anti-NA1 and -NA2 isoforms of Fc $\gamma$ RIIIb (the same targets recognized in ANN). Almost 85% of these antibodies are IgG. Other antigens toward which autoantibodies can be found are CD11b/CD18 (Mac-1), CD32 (Fc $\gamma$ RII) and CD35 (C3b complement receptor). The average age at diagnosis for primary AIN is 8 months. The majority of patients present with either skin or upper respiratory tract infections. Infrequently, some patients may suffer from severe infections such as pneumonia, meningitis or sepsis. The diagnosis may be incidental, as patients may remain asymptomatic despite low neutrophil counts. Monocytosis is also frequent. Neutrophil counts are usually below  $1,500/\mu\text{L}$ , but the majority of patients have  $>500$  neutrophils/ $\mu\text{L}$  at the time of diagnosis. The neutrophil count may increase 2-fold to 3-fold during severe infections and return to neutropenic levels following resolution. The bone marrow may be normal or hypercellular. The cause of this disease remains unknown. Detection of granulocyte-specific antibodies is key to the diagnosis of primary AIN and may require repeated testing.<sup>30</sup>

AIN is usually a self-limited disease. The neutropenia remits spontaneously within 7 to 24 months in 95% of patients, preceded by the disappearance of autoantibodies from the circulation. Symptomatic treatment with antibiotics for infections is usually sufficient. Treatment for severe infections or in the setting of emergency surgery often now includes G-CSF.<sup>30</sup>

### Secondary Autoimmune Neutropenia

Secondary AIN can be seen at any age but is more common in adults and has a more variable clinical course. Various systemic and autoimmune diseases such as systemic lupus erythematosus, Hodgkin's disease, large granular lymphocyte proliferation or leukemia, Epstein-Barr virus infection, cytomegalovirus infection, HIV infection and Parvovirus B19 infection have been associated with secondary AIN.<sup>30</sup> These patients are predisposed to the development of other autoimmune problems as well. Antineutrophil antibodies typically have pan-Fc $\gamma$ RIII specificity, rather than specificity to the Fc $\gamma$ RIII subunits, making the resulting neutropenia more severe. Anti-CD18/11b antibodies have been detected in a subset of patients. Secondary AIN responds best to therapy directed at the underlying cause.<sup>30</sup>

## Defects of Granule Formation and Content

### CHÉDIAK-HIGASHI SYNDROME

Chédiak-Higashi syndrome (CHS) is a rare and life-threatening autosomal recessive disease, characterized by oculocutaneous albinism, pyogenic infections, neurologic abnormalities and a late-onset hemophagocytic syndrome-like 'accelerated phase'. The disease is caused by mutations in the lysosomal trafficking



**Figure 11-1** Pigment distribution in hair. Normal hair (A) shows opacity typically located in the cortex of the hair shaft. In Chédiak-Higashi syndrome (B) small aggregates of clumped melanin are haphazardly distributed all along the hair shaft. (20 × magnification).

regulator gene, *LYST* or *CHS1*.<sup>31,32</sup> Patients show hypopigmentation of the skin, iris and hair due to giant and aberrant melanosomes (macromelanosomes). Hair color is usually light brown to blonde, with a characteristic metallic silver-gray sheen. Under light microscopy, CHS hair shafts show pathognomonic small, irregular aggregates of clumped pigment spread throughout the shaft (Figure 11-1).<sup>33-35</sup>

Giant azurophilic granules formed from the fusion of multiple primary granules are seen in neutrophils, eosinophils and basophils. Mild neutropenia due to intramedullary destruction is also common. Progressive neuropathy of the legs, cranial nerve palsies, seizures, mental retardation and autonomic dysfunction are also common.

The accelerated phase, one of the main causes of death in CHS, is clinically indistinguishable from other hemophagocytic syndromes, with fever, hepatosplenomegaly, lymphadenopathy, cytopenias, hypertriglyceridemia, hypofibrinogenemia, hemophagocytosis and tissue lymphohistiocytic infiltration. Etoposide (VP16), steroids and intrathecal methotrexate (when the CNS is involved) have been effective treatments. However, without successful bone marrow transplantation, the accelerated phase usually recurs.

### NEUTROPHIL-SPECIFIC GRANULE DEFICIENCY

Neutrophil-specific granule deficiency is a rare, heterogeneous, autosomal recessive disease characterized by the profound reduction or absence of neutrophil-specific granules and their contents.<sup>36</sup> In several cases a homozygous, recessive mutation was found in *C/EBPE*.<sup>37,38</sup> However, not all cases have mutations in *C/EBPE*, suggesting genetic heterogeneity.

Bilobed neutrophils are common (pseudo-Pelger-Huët anomaly), eosinophils may be unapparent in peripheral smears, and there is increased susceptibility to pyogenic infections of



the skin, ears, lungs and lymph nodes. Neutrophils have very low specific granule contents (e.g. lactoferrin) and low to absent defensins, a primary granule product. Hemostasis abnormalities, caused by reduced levels of platelet-associated high-molecular-weight von Willebrand factor and platelet fibrinogen and fibronectin, have been reported.<sup>39</sup>

Aggressive diagnosis of infection, prolonged and intensive therapy, and early use of surgical excision and debridement are necessary. Unrelated bone marrow transplantation corrected neutrophil-specific granule deficiency (*C/EBPE* mutation negative) in a 13-month-old patient with intractable diarrhea and severe infections.<sup>40</sup>

## Defects of Oxidative Metabolism

### CHRONIC GRANULOMATOUS DISEASE

Chronic granulomatous disease (CGD) predisposes to recurrent life-threatening infections caused by catalase-positive bacteria and fungi, and exuberant granuloma formation due to defects in the NADPH oxidase.<sup>38</sup> The NADPH oxidase exists as a heterodimeric membrane-bound complex embedded in the walls of secondary granules, and four distinct cytosolic proteins. These structural components are referred to as *phox* proteins (*phagocyte oxidase*). The secondary granule membrane complex is also called cytochrome *b*<sub>558</sub>, composed of a 91-kDa glycosylated  $\beta$  chain (gp91<sup>*phox*</sup>) and a 22-kDa non-glycosylated  $\alpha$  chain (p22<sup>*phox*</sup>), which together bind heme and flavin. The cytosol contains the structural components p47<sup>*phox*</sup> and p67<sup>*phox*</sup>, and the regulatory components p40<sup>*phox*</sup> and rac. On cellular activation the cytosolic components p47<sup>*phox*</sup> and p67<sup>*phox*</sup> associate with p40<sup>*phox*</sup> and rac, and these proteins combine with the cytochrome complex (gp91<sup>*phox*</sup> and p22<sup>*phox*</sup>) to form the intact NADPH oxidase. Superoxide is formed and, in the presence of superoxide dismutase, is converted to hydrogen peroxide, which, in the presence of myeloperoxidase and chlorine, is converted to bleach. It has been postulated that production of reactive oxygen species is most critical for microbial killing through the activation of certain primary granule proteins inside the phagosome.<sup>41</sup> This hypothesis for NADPH oxidase-mediated microbial killing suggests that the reactive oxidants are most critical as intracellular signaling molecules, leading to activation of other pathways rather than exerting a microbicidal effect per se.

Mutations in five genes of the NADPH oxidase have been found to cause CGD. Mutations in the X-linked gp91<sup>*phox*</sup> account for about two thirds of cases. The remainder are autosomal recessive; there are no autosomal dominant cases of CGD.<sup>38</sup> A single case of p40<sup>*phox*</sup> deficiency has been reported.<sup>42</sup> The frequency of CGD in the USA is higher than 1:200,000. Clinically, CGD is quite variable but the majority of patients are diagnosed as toddlers and young children.<sup>43</sup> Infections and granulomatous lesions are the usual first manifestations. The lung, skin, lymph nodes and liver are the most frequent sites of infection (Table 11-3). The majority of infections in CGD in North America are caused by only five organisms: *Staphylococcus aureus*, *Burkholderia cepacia* complex, *Serratia marcescens*, *Nocardia* and *Aspergillus*.<sup>43</sup> Trimethoprim-sulfamethoxazole prophylaxis has reduced the frequency of bacterial infections, especially with staphylococcus. On prophylaxis, staphylococcal infections are essentially confined to the liver and cervical lymph nodes.<sup>43</sup> Staphylococcal liver abscesses encountered in CGD are dense,

TABLE 11-3  
Prevalence of Infection by Site in 368 Patients with Chronic Granulomatous Disease

Type of Infection (Most Frequent Microorganisms Isolated)	Total (N = 368) No. (%)
Pneumonia ( <i>Aspergillus</i> spp; <i>Staphylococcus</i> spp; <i>Burkholderia cepacia</i> ; <i>Nocardia</i> spp; <i>Mycobacteria</i> spp)	290 (79%)
Abscess ( <i>Staphylococcus</i> spp; <i>Serratia</i> spp; <i>Aspergillus</i> spp)	250 (68%)
Suppurative adenitis ( <i>Staphylococcus</i> spp; <i>Serratia</i> spp; <i>Candida</i> spp)	194 (53%)
Osteomyelitis ( <i>Serratia</i> spp; <i>Aspergillus</i> spp; <i>Paecilomyces</i> spp; <i>Staphylococcus</i> spp)	90 (25%)
Bacteremia/fungemia ( <i>Salmonella</i> spp; <i>Burkholderia cepacia</i> ; <i>Candida</i> spp; <i>Staphylococcus</i> spp; <i>Pseudomonas</i> spp)	65 (18%)
Cellulitis ( <i>Chromobacterium violaceum</i> and <i>Serratia marcescens</i> were identified in one case each)	18 (5%)
Meningitis ( <i>Candida</i> spp was identified in three cases)	15 (4%)
Other†	112 (30%)

Modified from Winkelstein JA, Marino MC, Johnston RB Jr, et al. *Medicine* (Baltimore) 2000;79:155–69.

\*These data include patients on variable prophylactic regimens, if any, and are meant to portray the natural history of disease over the last 20 years.

†Includes impetigo, sinusitis, otitis media, septic arthritis, urinary tract infection/pyelonephritis, gingivitis/periodontitis, chorioretinitis, gastroenteritis, paronychia, conjunctivitis, hepatitis, epididymitis, empyema, epiglottitis, cardiac empyema, mastoiditis and suppurative phlebitis.

caseous and difficult to drain, and previously required surgery in almost all cases.<sup>44</sup> More recently, however, focusing on the dysregulated inflammatory response in CGD, a combination of steroid and antibiotic therapy has obviated the need for surgery in almost all cases.<sup>45</sup>

The gastrointestinal (Figure 11-2A) and genitourinary (Figure 11-2B) tracts are frequently affected by inflammatory and granulomatous manifestations in CGD patients. Gastrointestinal inflammatory manifestations occur in up to 43% of X-linked and 11% of autosomal recessive cases.<sup>46</sup> Recent analysis of older p47<sup>*phox*</sup> deficient patients suggests that even in that group the rate of inflammatory bowel disease is almost 40% by later adulthood (SMH, personal observation). Abdominal pain is the most common gastrointestinal symptom; diarrhea, nausea and vomiting also occur. Colonic granulomatous lesions mimicking Crohn's-like inflammatory bowel disease (IBD), oral ulcers, esophagitis, gastric outlet obstruction, villous atrophy, intestinal strictures, fistulae and perirectal abscesses also occur. The extraintestinal manifestations of Crohn's (pyoderma, arthritis) are typically absent.

Most CGD-associated IBD manifestations are responsive to steroids. Prednisone (1 mg/kg/day for several weeks followed by progressive tapering) usually resolves the symptoms. Unfortunately, relapses occur in nearly 70% of patients.<sup>45</sup> Low-dose maintenance prednisone may control symptoms without an apparent increase in serious infections. Sulfasalazine, mesalazine, 6-mercaptopurine, azathioprine and cyclosporine are effective second-line treatment options. The use of TNF- $\alpha$

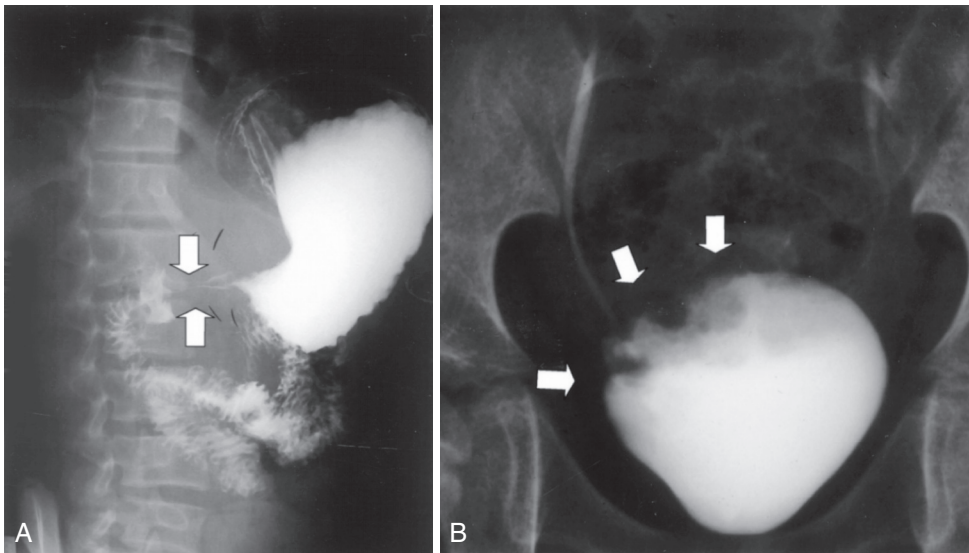

**Figure 11-2** Gastrointestinal and genitourinary obstructive lesions in chronic granulomatous disease. (A) High-grade obstruction of the gastric outlet in a 17-year-old boy with gp91<sup>phox</sup> deficient CGD (arrows). He had early satiety, weight loss and intermittent vomiting for several weeks. He improved rapidly on steroid therapy. (B) Extensive bladder granuloma formation in the superior aspect of the bladder in a 3-year-old boy with gp91<sup>phox</sup> deficient CGD (arrows). Note the mildly dilated ureter on the obstructed side. This child presented with dysuria and right hydronephrosis that responded promptly to steroids.

blocking antibodies in severe cases of IBD in CGD patients have been associated with symptom control in anecdotal reports but there were also severe infections with typical CGD pathogens.<sup>47</sup> Therefore, intensified prophylaxis and vigilance for intercurrent infections are needed in the setting of these potent immunosuppressives.

Genitourinary strictures and granulomas occur in up to 18% of CGD patients, mostly in the cytochrome b558-mutated patients.<sup>48</sup> Steroid therapy similar to that used for gastrointestinal manifestations usually controls these complications.<sup>49,50</sup>

Inflammatory retinal involvement is found in up to 24% of X-linked CGD patients. Interestingly, this has also been detected in three X-linked CGD female carriers. These lesions are typically nonprogressive and asymptomatic and need no specific treatment. However, two CGD patients needed enucleation for painful retinal detachments.<sup>51,52</sup> These retinal lesions have been found to have bacterial DNA within them, but the importance of this finding is unclear since they rarely change after discovery.<sup>53</sup>

Autoimmune disorders such as idiopathic thrombocytopenic purpura and juvenile rheumatoid arthritis are more common in CGD than in the general population.<sup>46,54,55</sup> Discoid and systemic lupus erythematosus occur in CGD patients and in X-linked CGD female carriers.

The X-linked carriers of gp91<sup>phox</sup> have one population of phagocytes that produces superoxide and one that does not, giving carriers a characteristic mosaic pattern on oxidative testing. Infections are not usually seen in these female carriers unless the normal neutrophils are below 10%, in which case these carriers are at risk for CGD type infections.<sup>43,56</sup>

The diagnosis of CGD is usually made by direct measurement of superoxide production, ferricytochrome c reduction, chemiluminescence, nitroblue tetrazolium (NBT) reduction or dihydrorhodamine oxidation (DHR). The DHR assay is preferred because of its relative ease of use, its ability to distinguish X-linked from autosomal patterns of CGD on flow cytometry, and its sensitivity to even very low numbers of functional neutrophils.<sup>57,58</sup> Of note, several other conditions, such as glucose-

6-phosphate dehydrogenase deficiency, myeloperoxidase deficiency, and synovitis, acne, pustulosis, hyperostosis and osteitis (SAPHO) can also affect the respiratory burst.<sup>54,55</sup>

Male sex, earlier age at presentation and increased severity of disease suggest X-linked disease, but the precise gene defect should be determined in all cases for the purposes of genetic counseling and prognosis. Autosomal recessive forms of CGD (mostly p47<sup>phox</sup> deficient) have a significantly better prognosis than X-linked disease.<sup>59</sup>

Prophylactic trimethoprim-sulfamethoxazole (5 mg/kg/day based on trimethoprim in two doses) reduces the frequency of major infections from about once every year to once every 3.5 years.<sup>60</sup> It reduces staphylococcal and skin infections without increasing the frequency of serious fungal infections in CGD.<sup>60</sup> Itraconazole prophylaxis prevents fungal infection in CGD (100 mg daily for patients <13 years or <50 kg; 200 mg daily for those ≥13 years or ≥50 kg).<sup>61</sup> IFN-γ also reduces the number and severity of infections in CGD by 70% compared to placebo, regardless of the inheritance pattern of CGD, sex or use of prophylactic antibiotics.<sup>62</sup> Therefore, our current recommendation is to use prophylaxis with trimethoprim-sulfamethoxazole, itraconazole and IFN-γ (50 μg/m<sup>2</sup>) in CGD. Because the differential diagnosis for a given process in these patients includes bacteria, fungi and granulomatous processes, a microbiologic diagnosis is critical. Leukocyte transfusions are often used for severe infections, but their efficacy is anecdotal.

Winkelstein and colleagues reported that mortality in the USA from the 1970s through 1990s was around 5% per year for the X-linked form of the disease and 2% per year for the autosomal recessive varieties.<sup>43</sup> The accumulated European experience from 1954 to 2003 found that autosomal recessive CGD patients had an average life expectancy of 50 years, while X-linked CGD patients had an average life expectancy of close to 38 years.<sup>63</sup> Mortality in CGD correlates with noncirrhotic portal hypertension and progressive damage of the hepatic microvasculature. Local or systemic infections, in addition to drug-induced liver injury, may be underlying conditions. A

history of liver abscess, alkaline phosphatase elevations and platelet decrease over time were individually associated with mortality in CGD patients.<sup>64</sup>

Successful hematopoietic stem cell transplantation (HSCT) provides a cure for CGD. Gungor and colleagues reported on 56 pediatric and adult European CGD patients transplanted with stem cells from matched siblings or matched unrelated donors, even in the setting of active inflammatory and infectious complications. They had an overall success rate of 93% with modest toxicity.<sup>65</sup>

Vectors providing normal *phox* genes can reconstitute NADPH oxidase activity in deficient cells, establishing the proof-of-principle for gene therapy in CGD. Several gene therapy protocols have been attempted, but they have been hampered by either retroviral-mediated myeloproliferative disease or poor persistence of transduced cells.<sup>66,67</sup> However, there are examples of at least transient benefit from gene therapy.<sup>68</sup> Newer protocols are using lentiviral vectors to avoid leukemogenesis and mild bone marrow ablation to permit more definitive engraftment.<sup>69</sup>

## MYELOPEROXIDASE DEFICIENCY

Myeloperoxidase (MPO) deficiency is the most common primary phagocyte disorder. It is an autosomal recessive disease with variable expressivity: 1:4,000 individuals have complete MPO deficiency, and 1:2,000 have a partial defect.<sup>70</sup> Myeloperoxidase catalyzes the conversion of H<sub>2</sub>O<sub>2</sub> to hypohalous acid. In those MPO-deficient patients who have had clinical findings, infections caused by different *Candida* strains were the most common: mucocutaneous, meningeal and bone infections, as well as sepsis, have been described.<sup>71-74</sup> Diabetes mellitus appears to be a critical co-factor for *Candida* infections in the context of MPO deficiency. A definitive diagnosis is established by sequencing of the MPO gene, neutrophil/monocyte peroxidase histochemical staining or specific protein detection. There is no specific treatment for MPO deficiency; diabetes should be sought and controlled, and infections should be treated.

## LEUKOCYTE ADHESION DEFICIENCY TYPE 1 (LAD1)

LAD1 is an autosomal recessive disorder produced by mutations in the common  $\beta$ 2 chain (CD18) of the  $\beta$ 2 integrin family

(*ITGB2*, 21q22.3; Table 11-4).<sup>75</sup> Each of the  $\beta$ 2 integrins is a heterodimer composed of an  $\alpha$  chain (CD11a, CD11b or CD11c), noncovalently linked to the common  $\beta$ 2 subunit (CD18). The  $\alpha$ - $\beta$  heterodimers of the  $\beta$ 2 integrin family include CD11a/CD18 (lymphocyte-function-associated antigen-1, LFA-1), CD11b/CD18 (macrophage antigen-1, Mac-1 or complement receptor-3, CR3) and CD11c/CD18 (p150,95 or complement receptor-4, CR4). CD18 is required for normal expression of the  $\alpha$ - $\beta$  heterodimers. Therefore, mutations resulting in failure to produce a functional  $\beta$ 2 subunit lead to either very low or no expression of CD11a, CD11b and/or CD11c, causing LAD1.<sup>75</sup>

The severe phenotype of LAD1 is caused by < 1% of normal expression of CD18 on neutrophils whereas the moderate phenotype shows from 1% to 30% of normal expression.<sup>76</sup> However, patients with normal  $\beta$ 2 integrin expression but without functional activity have also been described. Therefore, expression of CD18 alone is not sufficient to exclude the diagnosis of LAD1; functional assays must be performed if the clinical suspicion is high.<sup>76,77</sup>

Patients with the severe phenotype of LAD1 characteristically have delayed umbilical stump separation and omphalitis, persistent leukocytosis (>15,000/ $\mu$ L) even in the absence of infection, and severe, destructive gingivitis and periodontitis with associated loss of dentition and alveolar bone. Recurrent infections of the skin, upper and lower airways, bowel and perirectal area are common and usually caused by *S. aureus* or Gram-negative bacilli, but not by fungi. Infections tend to be necrotizing and may progress to ulceration (Figure 11-3). Typically, no pus is seen in these lesions and there is almost complete absence of neutrophil invasion. Aggressive medical management with antibiotics and neutrophil transfusions, and prompt surgery, when indicated, are required. Impaired healing of infectious, traumatic or surgical wounds is also characteristic of LAD1. Scars tend to acquire a dystrophic 'cigarette paper' appearance. Patients with the moderate phenotype tend to be diagnosed later in life, have normal umbilical cord separation, have fewer life-threatening infections and live longer. However, leukocytosis, periodontal disease and delayed wound healing are still common.<sup>76</sup>

Flow cytometry of LAD1 blood samples shows reduction (moderate phenotype) or near absence (severe phenotype) of CD18 and its associated molecules CD11a, CD11b and CD11c on neutrophils and other leukocytes. LAD1 patients show

TABLE 11-4 Leukocyte Adhesion Deficiency Syndromes

Leukocyte Adhesion Deficiency (LAD)	Type 1 (LAD1)	Type 2 (LAD2 or CDG-IIc)	Type 3 (LAD3)	Rac2 Deficiency
OMIM	116920	266265	612840	602049
Inheritance pattern	Autosomal recessive	Autosomal recessive	Autosomal recessive	Autosomal dominant
Affected protein(s)	Integrin $\beta$ 2 common chain (CD18)	Fucosylated proteins (e.g. sialyl-Lewis <sup>x</sup> , CD15s)	Kindlin 3	Rac2
Neutrophil function affected	Chemotaxis, tight adherence	Rolling, tethering	Chemotaxis, adhesion	Chemotaxis, superoxide production
Delayed umbilical cord separation	Yes (severe phenotype only)	Yes	Yes	Yes
Leukocytosis/neutrophilia	Yes	Yes	Yes	Yes

OMIM – Online Mendelian inheritance in man.





**Figure 11-3** Ulcerative perirectal lesion in an 18-year-old boy with LAD1. No pus was seen and there was poor inflammation in the surrounding tissues.

diminished neutrophil migration in vivo and in vitro.<sup>71</sup> Complement-mediated phagocytosis is severely impaired because of the absence of the complement receptor CD18/CD11b (CR3/Mac-1).

Somatic reversion of the mutation has been reported in LAD1 involving cytotoxic T lymphocytes.<sup>78</sup> However, bone marrow transplantation is the only definitive treatment.<sup>79</sup> Results on laboratory and animal gene therapy studies in LAD1 are provocative, but not yet available as a clinical indication.<sup>80</sup>

### LEUKOCYTE ADHESION DEFICIENCY TYPE 2 (LAD2) OR CONGENITAL DISORDER OF GLYCOSYLATION TYPE IIC (CDG-IIC)

LAD2, or CDG-IIC, is a very rare autosomal recessive inherited disease in which fucose metabolism is primarily affected because of mutations in the GDP-fucose transporter gene, *FUCT1*<sup>81,82</sup> (see Table 11-4).<sup>83,84</sup> Lack of the GDP-fucose transporter leads to a lack of expression of sialyl-Lewis<sup>x</sup> and other fucosylated proteins, impairing leukocyte rolling and adhesion. The phenotype is characterized by infections of the skin, lung and gums, leukocytosis and poor pus formation, as well as cognitive impairment, short stature, distinctive facies and the Bombay (hh) blood phenotype. The frequency and severity of infections tend to decline with time.<sup>85</sup> Fucose supplementation has had variable results.<sup>86,87</sup>

### LEUKOCYTE ADHESION DEFICIENCY TYPE 3 (LAD3)

LAD3 deficiency (previously known as LAD1 variant) resembles LAD1 on the one hand, but is associated with a syndrome similar to Glanzmann's thrombasthenia (a  $\beta 3$  integrin-related bleeding disorder) on the other. These patients present in infancy with severe bleeding and infections. Mortality is high, even with stem cell transplantation. LAD3 is due to mutations in *FERMT3*, the gene encoding kindlin-3, a molecule responsible for  $\beta 1$ ,  $\beta 2$  and  $\beta 3$  integrin activation in leukocytes and platelets.<sup>83,84</sup>

### RAC2 DEFICIENCY

Ambruso and colleagues<sup>88</sup> and Williams and colleagues<sup>89</sup> reported a male patient with an autosomal dominant mutation in the Rho GTPase *RAC2* gene (*RAC2*, see Table 11-4). This molecule is critical to the regulation of the actin cytoskeleton and superoxide production. The patient had delayed umbilical cord separation, perirectal abscesses, failure to heal surgical wounds and absent pus in infected areas, despite neutrophilia. Chemotaxis and superoxide production were impaired. In addition, the patient's neutrophils showed defective azurophilic granule release and impaired phagocytosis. He was cured by bone marrow transplantation. A second case was identified through newborn screening for T cell excision circles (TREC), although it is still unclear why TRECs are low in *RAC2* deficiency.<sup>90</sup>

### SYNDROMES WITH SUSCEPTIBILITY TO ENVIRONMENTAL MYCOBACTERIA

The mononuclear phagocyte is crucial for protection against intracellular infections, for antigen presentation, and for lymphocyte stimulation, lymphocyte proliferation, cytokine production and response. Transcription factors binding to the GATA sequence are critical for early hematopoiesis of myeloid and lymphoid cells as well as for normal vessel development.<sup>91</sup> Mycobacteria infect macrophages leading to the production of IL-12p70, a heterodimer of IL-12p40 and IL-12p35. IL-12 stimulates T cells and NK cells through its cognate receptor (IL-12R $\beta 1$  and IL-12R $\beta 2$ ) to phosphorylate STAT4 and produce IFN- $\gamma$ . IFN- $\gamma$  acts through its heterodimeric receptor (IFN $\gamma$ R1/IFN $\gamma$ R2) to phosphorylate STAT1 and turn on interferon-responsive genes such as interferon response factor 8 (IRF8) and interferon stimulated gene 15 (ISG15) (Figure 11-4).<sup>92,93</sup> In response to diverse signals, NF- $\kappa$ B essential modulator (NEMO) mediates the activation of the central transcription factor NF- $\kappa$ B. This transcription factor is therefore central to both immune and somatic pathways.<sup>94</sup>

Patients with defects in *GATA2*, *IL12B*, *IFNGR1*, *IFNGR2*, *IL12RB1*, *STAT1*, *NEMO*, *IRF8* and *ISG15* have been identified through their susceptibility to mycobacteria, as well as other intracellular infections including *Salmonella*.<sup>92,93,95,96</sup> There is also a role for superoxide in the killing of mycobacteria, as reflected in the higher rates of tuberculosis in CGD and BCG infection in two families with unusual mutations in the *CYBB* gene.<sup>97</sup>

Haploinsufficiency for the transcription factor *GATA2* leads to a late-onset immunodeficiency characterized by disseminated mycobacterial and viral (HPV, herpesviruses) infections often associated with diminished monocytes, B cells and NK cells in peripheral blood accompanied by myelodysplasia.<sup>98</sup>

Patients with autosomal recessive mutations leading to abolition of IFN $\gamma$ R1, IFN $\gamma$ R2 or STAT1 expression or function present early in life, especially if they receive BCG vaccination. In contrast, patients with an autosomal dominant mutation in *IFNGR1* as a result of a recurrent 4 base deletion (named 818del4) have only partial inhibition of receptor function. Patients with dominant *IFNGR1* mutations may present before the age of 7 with pulmonary nontuberculous mycobacterial infection but then characteristically go on to develop recurrent nontuberculous osteomyelitis.



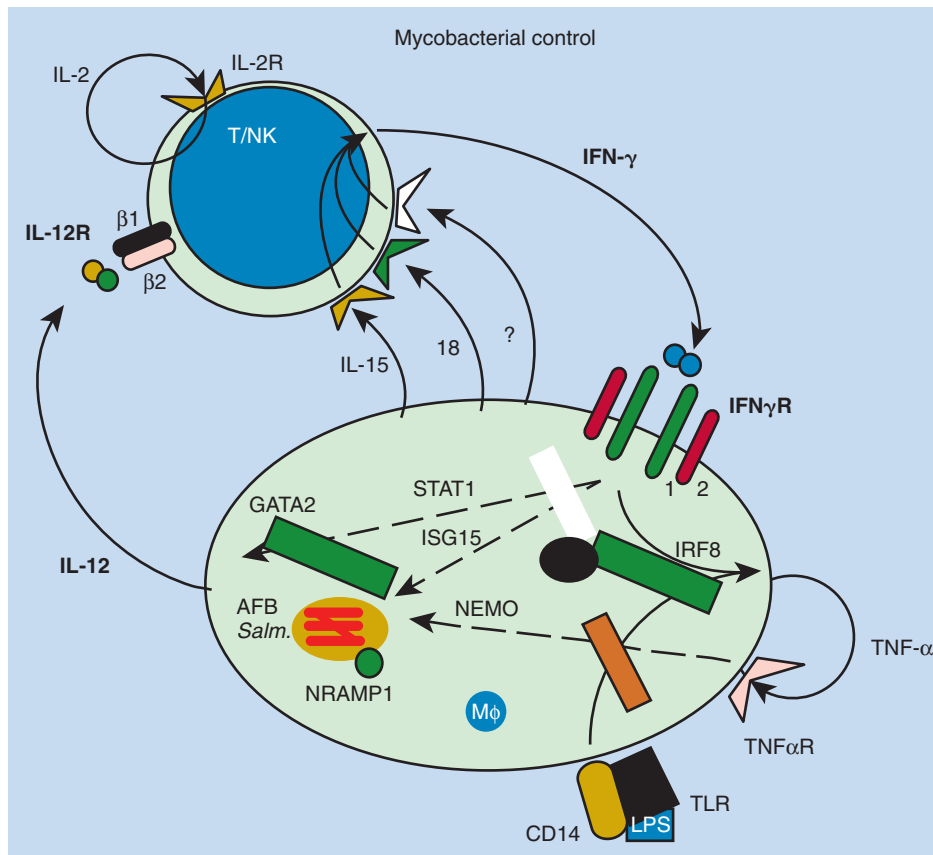

**Figure 11-4** Schematic representation of the IFN- $\gamma$ /IL-12 pathway. Ingested pathogens such as acid-fast bacilli (AFB) or salmonella (*Salm.*) stimulate IL-12 production by macrophages (M $\Phi$ ). Acting through its cognate IL-12 receptor, composed of the IL-12 receptor  $\beta$ 1 chain (IL-12R $\beta$ 1) and the IL-12 receptor  $\beta$ 2 chain (IL-12R $\beta$ 2), IL-12 stimulates T and NK cells to produce IFN- $\gamma$  and IL-2. Homodimeric IFN- $\gamma$  binds to the interferon  $\gamma$  receptor complex (IFN- $\gamma$ R). IFN- $\gamma$  receptor 1 (IFN- $\gamma$ R1) is the binding chain whereas IFN- $\gamma$  receptor 2 (IFN- $\gamma$ R2) is necessary to transmit the signal intracellularly through the signal transduction and activator of transcription 1 (STAT1). The mechanisms by which IFN- $\gamma$  stimulates intracellular microorganism killing are not fully understood, but are likely to be numerous (e.g. upregulation of MHC expression and IL-12 production, enhancing of antigen processing and reactive oxygen species production, reducing the phagosomal pH). IFN- $\gamma$  also stimulates TNF- $\alpha$  production. TNF- $\alpha$ , acting through the TNF- $\alpha$  receptor (TNF- $\alpha$ R), also shows effects against intracellular infections. Patients with mutations in the NF- $\kappa$ B essential modulator (NEMO), a protein critical in the TNF- $\alpha$  signaling pathway, have enhanced susceptibility to mycobacterial disease as well as other infections. IL-12 is not the only cytokine that stimulates IFN- $\gamma$  production: IL-15, IL-18, and probably other factors have the same effect. The lack of mycobacterium-induced ISG15 secretion by leukocytes – granulocytes in particular – reduces the production of IFN- $\gamma$  by lymphocytes, including natural killer cells, probably accounting for the enhanced susceptibility to mycobacterial disease. IRF8 is critical for the development of monocytes and dendritic cells and for antimycobacterial immunity. Lipopolysaccharide (LPS) stimulation through the CD14/Toll-like receptor 2 (TLR2) complex can also stimulate IL-12 production.

Patients with mutations in IL-12p40 or IL-12R $\beta$ 1 and those with dominant negative *STAT1* mutations usually have less severe phenotypes. In IL-12R $\beta$ 1 deficiency the risk for nontuberculous mycobacterial infection wanes after age 12.<sup>99</sup> IRF8 defects are quite rare. One homozygous child had severe BCG infection with myeloproliferation, while two others with dominant negative *IRF8* mutations developed mild but recurrent disseminated BCG.<sup>92</sup> The three patients reported with *ISG15* defects had disseminated BCG shortly after vaccination but were eventually responsive to therapy.<sup>93</sup>

NEMO is encoded by a gene (*IKBKG*) on the X chromosome, and hypomorphic NEMO mutations cause disease in hemizygous males (hypomorphic mutations are mostly asymptomatic in females). Hemizygous males may have a complex phenotype including hypohidrotic ectodermal dysplasia, immune deficiency and, rarely, lymphedema with osteopetrosis. Almost 40% of males with hypomorphic mutations in NEMO develop mycobacterial infections, mostly with environmental organisms.<sup>100</sup> In heterozygous females, amorphic NEMO mutations are associated with incontinentia pigmenti.<sup>101</sup>

Flow cytometry is very efficient in detection of IFNGR1 defects, as this protein is expressed on all nucleated cells all the time. In the case of autosomal dominant IFNGR1 deficiency, the protein is overabundant on the cell surface and therefore very easy to detect.<sup>102</sup> In contrast, detection of IFNGR2 and IL-12R $\beta$ 1 often requires cell culture and proliferation. Detection of intracellular phosphorylated STAT1 after IFN- $\gamma$  stimulation, or phosphorylated STAT4 after IL-12 stimulation, is an indirect means of demonstrating functional integrity of the IFN- $\gamma$  and IL-12 receptors, respectively.<sup>103,104</sup> Direct detection of IL-12p40 or IL-12p70 can be used for the diagnosis of patients who are deficient in IL-12p40. Demonstrating defects in *STAT1* requires research techniques.

Treatment of infection in these patients poses special problems. IFN- $\gamma$  is of no help for the patients with complete IFN $\gamma$ R defects. However, in patients with autosomal dominant IFN $\gamma$ R1 deficiency, IL-12 defects or IL-12R defects, IFN- $\gamma$  is usually effective. However, about 30% of those with IL-12R $\beta$ 1 deficiency die, suggesting complex modifying factors.<sup>105</sup> Bone marrow transplantation for IFN $\gamma$ R defects has

been disappointing overall, for reasons that are still unclear. Long-term prophylaxis against environmental mycobacterial infections with a macrolide such as azithromycin or clarithromycin seems advisable.

### HYPER-IgE SYNDROME (HIES; JOB'S SYNDROME)

Hyper-IgE (HIES or Job's) syndrome is due to heterozygous (autosomal dominant inheritance) mutations in *STAT3* and characterized by elevated serum immunoglobulin E (IgE), eczema, recurrent skin and lung infections, and somatic features including characteristic facies, scoliosis and fractures<sup>106-108</sup> (Table 11-5). Human mutations found thus far allow the production of full-length mutant *STAT3* protein, which exerts dominant negative effects.

A newborn rash is usually the first manifestation of Job's syndrome. About one fifth have the rash at birth, and one quarter develop it in the first week of life. Mucocutaneous candidiasis is common, typically as oral thrush, vaginal candidiasis or onychomycosis; systemic *Candida* infections are very rare.<sup>106</sup> Cutaneous 'cold' abscesses are common and caused by *S. aureus* infections. Antistaphylococcal antibiotics or topical antiseptics, such as bleach baths, are effective.

Recurrent pneumonias caused by *S. aureus*, *Streptococcus pneumoniae* and *Haemophilus influenzae* typically start in childhood, with a paucity of symptoms. Pneumatoceles and bronchiectasis form during the healing process and usually persist once the infection has cleared. These anatomic abnormalities predispose the patient to Gram-negative bacterial (typically *Pseudomonas*) and fungal (typically *Aspergillus* or *Scedosporium* species) infections. The large cysts often become secondarily infected and may bleed, sometimes fatally. On the other hand, thoracic surgery can be complicated by poor healing of the remaining lung, often resulting in persistent air leak.<sup>109</sup> Antimicrobial prophylaxis to prevent *S. aureus* skin and lung infection (e.g. trimethoprim-sulfamethoxazole) may be broadened if Gram-negative lung infections occur. Antifungal prophylaxis to prevent pulmonary aspergillosis remains attractive but unproven, but it is highly effective in treating and preventing mucocutaneous candidiasis.

TABLE 11-5

Clinical Characteristics of Hyper-IgE Syndrome with *STAT3* Mutations

Clinical Findings in HIES	
Eczema	100%
Peak IgE > 2,000 IU/mL	97%
Eosinophilia	93%
Recurrent pneumonias	87%
Characteristic face	83%
Mucocutaneous candidiasis	83%
Pneumatoceles	77%
Retained primary teeth	72%
Pathologic fractures	71%
Focal brain hyperintensities	70%
Scoliosis (>16 years, >10°)	63%

Scoliosis, osteopenia, minimal trauma fractures, hyperextensibility, degenerative joint disease, craniosynostosis and Chiari 1 malformations also occur frequently but seldom need surgical correction.<sup>110</sup> The general mechanism underlying bone abnormalities is unknown and the role of bisphosphonates in treating the osteoporosis and minimal trauma fractures in HIES is undefined.

In childhood and adolescence, most Job's or HIES patients develop characteristic facial features including facial asymmetry, broad nose and deep-set eyes with a prominent forehead. Most patients retain some, if not all, of their primary teeth past the age of normal primary dental exfoliation; at times, layers of both primary and secondary teeth co-exist.<sup>106,110</sup> Vascular abnormalities are common in Job's including coronary artery aneurysms,<sup>111</sup> dilatations and tortuosities, carotid artery berry aneurysms and early-onset MRI T2-weighted hyperintensities (unidentified bright objects or UBOs).<sup>112</sup> As reported in other primary immunodeficiency diseases affecting lymphocytes, both Hodgkin's and non-Hodgkin lymphomas are significantly increased in Job's syndrome.<sup>113</sup>

DOCK8 deficiency is an autosomal recessive syndrome with IgE elevation, severe eczema and recurrent skin and lung infections. However, in distinction to Job's syndrome, DOCK8 deficiency is characterized by cutaneous viral infections (molluscum contagiosum, herpes simplex, HPV) and severe allergic diathesis.<sup>114-116</sup> Severe eczematoid rashes start early in life, although not necessarily in the newborn period. Unlike Job's syndrome, pneumonias due to *S. aureus*, *H. influenzae*, *Proteus mirabilis*, *Pseudomonas aeruginosa*, and *Cryptococcus* typically heal without pneumatocele formation. DOCK8 deficiency lacks the somatic features of Job's syndrome.

Tyk2 deficiency is another autosomal recessive syndrome with IgE elevation and susceptibility to infection. The few cases identified suggest that this may present either as an IgE elevation syndrome or one of mycobacterial susceptibility.<sup>117,118</sup>

### Mucocutaneous Candidiasis

*Candida* species are commonly found on mucosal surfaces, where they are commensal. The innate response to *Candida* appears to depend heavily on the production of IL-17 by dedicated Th17 lymphocytes. Accordingly, those mutations that affect IL-17-producing T cells are strongly associated with mucocutaneous candidiasis.<sup>119</sup> *Candida* sensing at the cellular level seems to depend on the surface receptor dectin-1 and its signal transduction pathway including CARD9.<sup>120</sup> Mutations in dectin-1 have also been identified but their etiologic role in severe mucocutaneous candidiasis is hard to assign because of the common occurrence of some of these mutations.<sup>121</sup> Dominant negative mutations in *STAT3* (Job's syndrome) lead to impaired Th17 production and mucocutaneous candidiasis.<sup>107,108</sup> More surprising is the discovery that dominant gain-of-function mutations in *STAT1* also lead to Th17 deficiency and severe mucocutaneous candidiasis, apparently through the oversignaling of IFN- $\gamma$ .<sup>122,123</sup> These syndromes are critical to consider, as homozygous recessive CARD9 deficiency can be associated with severe dermatophyte infections as well as fungal brain infections.<sup>124</sup> Dominant heterozygous gain-of-function *STAT1* mutations can be associated with disseminated coccidioidomycosis, disseminated histoplasmosis and progressive multifocal leukoencephalopathy.<sup>125</sup>

**BOX 11-2 KEY CONCEPTS****White Blood Cell Defects: Evaluation and Management**

Patients with white cell defects usually present early in life with recurrent bacterial or fungal infections.

Certain infections, such as *B. cepacia*, *Nocardia*, or environmental mycobacteria should always prompt an inquiry into the possibility of an underlying immune defect.

Specific infection locations, such as omphalitis or osteomyelitis, should raise the suspicion of immune abnormalities.

Abnormal aspects of host response, such as lack of fever, local inflammation or pus, should immediately alert the clinician to the possibility of a white cell defect.

It is better to perform the right test once than the entire battery of immune defect tests several times. Careful consideration of the clinical and microbiologic presentation usually indicates the right path to pursue.

There is no substitute for the right drug, and that requires knowing the pathogen. Because the spectrum of infection in these diseases may range over several microbiologic kingdoms, empiric therapy is to be discouraged in favor of firm diagnoses.

Prophylactic antibiotics, antifungal agents and cytokines are highly successful in treating chronic granulomatous disease, and appear to be useful in some other immunodeficiencies as well.

A molecular diagnosis should be sought whenever possible. The expanding knowledge of genotype-phenotype relationships suggests that not all defects, even those within the same gene, are created equal.

**Conclusions**

Various defects of phagocytes have been elucidated over the last several decades. Despite the fact that profound neutropenia predisposes patients to most members of the bacterial and fungal kingdoms, metabolic defects in neutrophils and monocytes have relatively narrow spectra of infection. Some of these disorders have almost pathognomonic infection profiles (e.g. CGD, IFN- $\gamma$ /IL-12 pathway defects). We have now put genetic faces to some of the names of these puzzling diseases. The simple recognition of genes and pathways should not be confused with careful and complete understanding of mechanism. The latter, despite all the complex diagrams, remains elusive (Boxes 11-2 and 11-3). Although we have been very successful

**BOX 11-3 THERAPEUTIC PRINCIPLES**

- In general, attenuated or inactivated viral vaccines are not contraindicated in individuals with primary phagocyte disorders, because antiviral cell-mediated immunity is intact.
- BCG vaccination should be avoided in individuals with CGD or MSMD pathway defects, as well as in their newborn close relatives, until the defect is ruled out.
- Mulching and gardening should be avoided by individuals with increased susceptibility to *Aspergillus* infections, such as patients with CGD, HIES or neutropenia.
- Patients with white blood cell defects often fail to mount a normal inflammatory response, so clinicians and parents must keep a high index of suspicion for asymptomatic or hyposymptomatic infection.
- Standard recommendations for duration of therapy of infections are based on experience in normal people. In the patient with a white cell defect, the host contribution to resolution of infection may be relatively small, resulting in a need for longer or more intensive antibiotic or antifungal therapy.
- When infections are necrotizing or poorly responsive to antibiotic therapy, surgery may be needed, even in situations in which it would not be needed in unaffected individuals (e.g. lymphadenitis in CGD often needs operative removal).
- Obtain experienced expert advice whenever possible.

at identifying rare and flagrant defects affecting white cells that lead to severe infections, the more subtle defects that cause recurrent staphylococcal infections, hydradenitis and infections in diabetes, to name only a few of the vexing problems that frequently confront the clinical immunologist, remain to be determined. Careful study of the known pathways, assiduous following of the ramifications of those pathways to the points where they merge with new pathways, and conscientious characterization of clinical phenotypes will lead to the discovery of these remaining immune defects. In the process we will gain new insights into exactly how we remain so remarkably healthy in the face of so many daily microbial challenges.

The complete reference list can be found on the companion Expert Consult website at <http://www.expertconsult.inkling.com>.

**KEY REFERENCES**

- Klein C. Genetic defects in severe congenital neutropenia: emerging insights into life and death of human neutrophil granulocytes. *Annu Rev Immunol* 2011;29:399–413.
- Winkelstein JA, Marino MC, Johnston RB Jr, Boyle J, Curnutte J, Gallin JI, et al. Chronic granulomatous disease. Report on a national registry of 368 patients. *Medicine* 2000;79:155–69.
- Kuhns DB, Alvord WG, Heller T, Heller T, Feld JJ, Pike KM, et al. Residual NADPH oxidase and survival in chronic granulomatous disease. *N Engl J Med* 2010;363:2600–10.
- van den Berg JM, van Koppen E, Ahlin A, Belohradsky BH, Bernatowska E, Corbeel L, et al. Chronic granulomatous disease: the European experience. *PLoS ONE* 2009;4:e5234.
- Notarangelo LD, Badolato R. Leukocyte trafficking in primary immunodeficiencies. *J Leukoc Biol* 2009;85:335–43.
- Al-Muhsen S, Casanova JL. The genetic heterogeneity of Mendelian susceptibility to mycobacterial diseases. *J Allergy Clin Immunol* 2008;122:1043–51, quiz 1052–3.
- Spinner MA, Sanchez LA, Hsu AP, Shaw PA, Zerbe CS, Calvo KR, et al. GATA2 deficiency: a protean disorder of hematopoiesis, lymphatics, and immunity. *Blood* 2014;123:809–21.
- de Beaucoudrey L, Samarina A, Bustamante J, Cobat A, Boisson-Dupuis S, Feinberg J, et al. Revisiting human IL-12Rbeta1 deficiency: a survey of 141 patients from 30 countries. *Medicine* 2010;89:381–402.
- Freeman AF, Holland SM. The hyper-IgE syndromes. *Immunol Allergy Clin North Am* 2008;28:277–91, viii.
- Puel A, Cypowij S, Marodi L, Abel L, Picard C, Casanova JL. Inborn errors of human IL-17 immunity underlie chronic mucocutaneous candidiasis. *Curr Opin Allergy Clin Immunol* 2012;12:616–22.

## REFERENCES

- Dale DC, Cottle TE, Fier CJ, Bolyard AA, Bonilla MA, Boxer LA, et al. Severe chronic neutropenia: treatment and follow-up of patients in the Severe Chronic Neutropenia International Registry. *Am J Hematol* 2003;72:82–93.
- Klein C. Genetic defects in severe congenital neutropenia: emerging insights into life and death of human neutrophil granulocytes. *Annu Rev Immunol* 2011;29:399–413.
- Kostmann R. Infantile genetic agranulocytosis; agranulocytosis infantilis hereditaria. *Acta Paediatr Suppl* 1956;45(Suppl. 105):1–78.
- Klein C, Grudzien M, Appaswamy G, Germeshausen M, Sandrock I, Schäffer AA, et al. HAX1 deficiency causes autosomal recessive severe congenital neutropenia (Kostmann disease). *Nat Genet* 2007;39:86–92.
- Germeshausen M, Grudzien M, Zeidler C, Abdollahpour H, Yetgin S, Rezaei N, et al. Novel HAX1 mutations in patients with severe congenital neutropenia reveal isoform-dependent genotype-phenotype associations. *Blood* 2008;111:4954–7.
- Dong F, Brynes RK, Tidow N, Welte K, Lowenberg B, Touw IP. Mutations in the gene for the granulocyte colony-stimulating-factor receptor in patients with acute myeloid leukemia preceded by severe congenital neutropenia. *N Engl J Med* 1995;333:487–93.
- Germeshausen M, Skokowa J, Ballmaier M, Zeidler C, Welte K. G-CSF receptor mutations in patients with congenital neutropenia. *Curr Opin Hematol* 2008;15:332–7.
- Boztug K, Appaswamy G, Ashikov A, Schäffer AA, Salzer U, Diestelhorst J, et al. A syndrome with congenital neutropenia and mutations in G6PC3. *N Engl J Med* 2009;360:32–43.
- Horwitz M, Benson KF, Person RE, Aprikyan AG, Dale DC. Mutations in ELA2, encoding neutrophil elastase, define a 21-day biological clock in cyclic haematopoiesis. *Nat Genet* 1999;23:433–6.
- Dale DC, Person RE, Bolyard AA, Aprikyan AG, Bos C, Bonilla MA, et al. Mutations in the gene encoding neutrophil elastase in congenital and cyclic neutropenia. *Blood* 2000;96:2317–22.
- Horwitz MS, Duan Z, Korkmaz B, Lee HH, Mealiffe ME, Salipante SJ. Neutrophil elastase in cyclic and severe congenital neutropenia. *Blood* 2007;109:1817–24.
- Devriendt K, Kim AS, Mathijs G, Frints SG, Schwartz M, Van Den Oord JJ, et al. Constitutively activating mutation in WASP causes X-linked severe congenital neutropenia. *Nat Genet* 2001;27:313–17.
- Person RE, Li FQ, Duan Z, Benson KF, Wechsler J, Papadaki HA, et al. Mutations in proto-oncogene GFI1 cause human neutropenia and target ELA2. *Nat Genet* 2003;34:308–12.
- Wright DG, Dale DC, Fauci AS, Wolff SM. Human cyclic neutropenia: clinical review and long-term follow-up of patients. *Medicine* 1981;60:1–13.
- Dale DC, Hammond WP. Cyclic neutropenia: a clinical review. *Blood Rev* 1988;2:178–85.
- Palmer SE, Stephens K, Dale DC. Genetics, phenotype, and natural history of autosomal dominant cyclic hematopoiesis. *Am J Med Genet* 1996;66:413–22.
- Soud AK. Congenital cyclic neutropenia. *Clin Pediatr (Phila)* 1995;34:151–5.
- Prochorec-Sobieszek M. Advances in diagnosis and treatment of large granular lymphocyte syndrome. *Curr Opin Hematol* 2011;18:55–62.
- Hernandez PA, Gorlin RJ, Lukens JN, Taniuchi S, Bohinjec J, Francois F, et al. Mutations in the chemokine receptor gene CXCR4 are associated with WHIM syndrome, a combined immunodeficiency disease. *Nat Genet* 2003;34:70–4.
- Balabanian K, Lagane B, Pablos JL, Laurent L, Planchenault T, Verola O, et al. WHIM syndromes with different genetic anomalies are accounted for by impaired CXCR4 desensitization to CXCL12. *Blood* 2005;105:2449–57.
- Balabanian K, Levoe A, Klemm L, Lagane B, Hermine O, Harriague J, et al. Leukocyte analysis from WHIM syndrome patients reveals a pivotal role for GRK3 in CXCR4 signaling. *J Clin Invest* 2008;118:1074–84.
- Kawai T, Malech HL. WHIM syndrome: congenital immune deficiency disease. *Curr Opin Hematol* 2009;16:20–6.
- McDermott DH, Liu Q, Ulrick J, Kwatema N, Anaya-O'Brien S, Penzak SR, et al. The CXCR4 antagonist plerixafor corrects panleukopenia in patients with WHIM syndrome. *Blood* 2011;118:4957–62.
- McDermott DH, Liu Q, Velez D, Lopez L, Anaya-O'Brien S, Ulrick J, et al. A phase 1 clinical trial of long-term, low-dose treatment of WHIM syndrome with the CXCR4 antagonist plerixafor. *Blood* 2014;123:2308–16.
- Dale DC. Immune and idiopathic neutropenia. *Curr Opin Hematol* 1998;5:33–6.
- Huizinga TW, Kuijpers RW, Kleijer M, Schulp TW, Cuypers HT, Roos D, et al. Maternal genomic neutrophil FcRIII deficiency leading to neonatal isoimmune neutropenia. *Blood* 1990;76:1927–32.
- Stroncek DF, Skubitz KM, Plachta LB, Shankar RA, Clay ME, Herman J, et al. Alloimmune neonatal neutropenia due to an antibody to the neutrophil Fc-gamma receptor III with maternal deficiency of CD16 antigen. *Blood* 1991;77:1572–80.
- Fromont P, Bettaieb A, Skouri H, Floch C, Poulet E, Duedari N, et al. Frequency of the polymorphonuclear neutrophil Fc gamma receptor III deficiency in the French population and its involvement in the development of neonatal alloimmune neutropenia. *Blood* 1992;79:2131–4.
- Clay ME, Schuller RM, Bachowski GJ. Granulocyte serology: current concepts and clinical significance. *Immunohematology* 2010;26:11–21.
- Akhtari M, Curtis B, Waller EK. Autoimmune neutropenia in adults. *Autoimmun Rev* 2009;9:62–6.
- Barbosa MD, Nguyen QA, Tchernev VT, Ashley JA, Detter JC, Blaydes SM, et al. Identification of the homologous beige and Chediak-Higashi syndrome genes. *Nature* 1996;382:262–5.
- Nagle DL, Karim MA, Woolf EA, Holmgren L, Bork P, Misumi DJ, et al. Identification and mutation analysis of the complete gene for Chediak-Higashi syndrome. *Nat Genet* 1996;4:307–11.
- Introne W, Boissy RE, Gahl WA. Clinical, molecular, and cell biological aspects of Chediak-Higashi syndrome. *Mol Genet Metab* 1999;68:283–303.
- Huizinga M, Helip-Wooley A, Westbroek W, Gunay-Aygun M, Gahl WA. Disorders of lysosome-related organelle biogenesis: clinical and molecular genetics. *Annu Rev Genomics Hum Genet* 2008;9:359–86.
- Blume RS, Wolff SM. The Chediak-Higashi syndrome: studies in four patients and a review of the literature. *Medicine* 1972;51:247–80.
- Gallin JI, Fletcher MP, Seligmann BE, Hoffstein S, Cehrs K, Mounessa N. Human neutrophil-specific granule deficiency: a model to assess the role of neutrophil-specific granules in the evolution of the inflammatory response. *Blood* 1982;59:1317–29.
- Lekstrom-Himes JA, Dorman SE, Kopar P, Holland SM, Gallin JI. Neutrophil-specific granule deficiency results from a novel mutation with loss of function of the transcription factor CCAAT/enhancer binding protein epsilon. *J Exp Med* 1999;189:1847–52.
- Segal BH, Leto TL, Gallin JI, Malech HL, Holland SM. Genetic, biochemical, and clinical features of chronic granulomatous disease. *Medicine* 2000;79:170–200.
- Gombart AF, Koeffler HP. Neutrophil specific granule deficiency and mutations in the gene encoding transcription factor C/EBP(epsilon). *Curr Opin Hematol* 2002;9:36–42.
- Wynn RF, Sood M, Theilgaard-Monch K, Jones CJ, Gombart AF, Gharib M, et al. Intractable diarrhoea of infancy caused by neutrophil specific granule deficiency and cured by stem cell transplantation. *Gut* 2006;55:292–3.
- Reeves EP, Lu H, Jacobs HL, Messina CG, Bolsover S, Gabella G, et al. Killing activity of neutrophils is mediated through activation of proteases by K+ flux. *Nature* 2002;416:291–7.
- Matute JD, Arias AA, Wright NA, Wrobel I, Waterhouse CC, Li XJ, et al. A new genetic subgroup of chronic granulomatous disease with autosomal recessive mutations in p40 phox and selective defects in neutrophil NADPH oxidase activity. *Blood* 2009;114:3309–15.
- Winkelstein JA, Marino MC, Johnston RB Jr, Boyle J, Curnutte J, Gallin JI, et al. Chronic granulomatous disease. Report on a national registry of 368 patients. *Medicine* 2000;79:155–69.
- Lublin M, Bartlett DL, Danforth DN, Kauffman H, Gallin JI, Malech HL, et al. Hepatic abscess in patients with chronic granulomatous disease. *Ann Surg* 2002;235:383–91.
- Leiding JW, Freeman AF, Marciano BE, Anderson VL, Uzel G, Malech HL, et al. Corticosteroid therapy for liver abscess in chronic granulomatous disease. *Clin Infect Dis* 2012;54:694–700.
- Marciano BE, Rosenzweig SD, Kleiner DE, Anderson VL, Darnell DN, Anaya-O'Brien S, et al. Gastrointestinal involvement in chronic granulomatous disease. *Pediatrics* 2004;114:462–8.
- Uzel G, Orange JS, Poliak N, Marciano BE, Heller T, Holland SM. Complications of tumor necrosis factor-alpha blockade in chronic granulomatous disease-related colitis. *Clin Infect Dis* 2010;51:1429–34.
- Walther MM, Malech H, Berman A, Choyke P, Venzon DJ, Linehan WM, et al. The urological



- manifestations of chronic granulomatous disease. *J Urol* 1992;147:1314–18.
49. Chin TW, Stiehm ER, Falloon J, Gallin JI. Corticosteroids in treatment of obstructive lesions of chronic granulomatous disease. *J Pediatr* 1987;111:349–52.
  50. Quie PG, Belani KK. Corticosteroids for chronic granulomatous disease. *J Pediatr* 1987;111:393–4.
  51. Goldblatt D, Butcher J, Thrasher AJ, Russell-Eggitt I. Chorioretinal lesions in patients and carriers of chronic granulomatous disease. *J Pediatr* 1999;134:780–3.
  52. Kim SJ, Kim JG, Yu YS. Chorioretinal lesions in patients with chronic granulomatous disease. *Retina* 2003;23:360–5.
  53. Wang Y, Marciano BE, Shen D, Bishop RJ, Park S, Holland SM, et al. Molecular identification of bacterial DNA in the chorioretinal scars of chronic granulomatous disease. *J Clin Immunol* 2013;33:917–24.
  54. Mauch L, Lun A, O’Gorman MR, Harris JS, Schulze I, Zychlinsky A, et al. Chronic granulomatous disease (CGD) and complete myeloperoxidase deficiency both yield strongly reduced dihydrorhodamine 123 test signals but can be easily discerned in routine testing for CGD. *Clin Chem* 2007;53:890–6.
  55. Ferguson PJ, Lokuta MA, El-Shanti HI, Muhle L, Bing X, Huttenlocher A. Neutrophil dysfunction in a family with a SAPHO syndrome-like phenotype. *Arthritis Rheum* 2008;58:3264–9.
  56. Anderson-Cohen M, Holland SM, Kuhns DB, Fleisher TA, Ding L, Brenner S, et al. Severe phenotype of chronic granulomatous disease presenting in a female with a de novo mutation in gp91-phox and a non familial, extremely skewed X chromosome inactivation. *Clin Immunol* 2003;109:308–17.
  57. Vowells SJ, Sekhsaria S, Malech HL, Shalit M, Fleisher TA. Flow cytometric analysis of the granulocyte respiratory burst: a comparison study of fluorescent probes. *J Immunol Methods* 1995;178:89–97.
  58. Vowells SJ, Fleisher TA, Sekhsaria S, Alling DW, Maguire TE, Malech HL. Genotype-dependent variability in flow cytometric evaluation of reduced nicotinamide adenine dinucleotide phosphate oxidase function in patients with chronic granulomatous disease. *J Pediatr* 1996;128:104–7.
  59. Kuhns DB, Alvord WG, Heller T, Heller T, Feld JJ, Pike KM, et al. Residual NADPH oxidase and survival in chronic granulomatous disease. *N Engl J Med* 2010;363:2600–10.
  60. Margolis DM, Melnick DA, Alling DW, Gallin JI. Trimethoprim-sulfamethoxazole prophylaxis in the management of chronic granulomatous disease. *J Infect Dis* 1990;162:723–6.
  61. Gallin JI, Alling DW, Malech HL, Wesley R, Koziol D, Marciano B, et al. Itraconazole to prevent fungal infections in chronic granulomatous disease. *N Engl J Med* 2003;348:2416–22.
  62. A controlled trial of interferon gamma to prevent infection in chronic granulomatous disease. The International Chronic Granulomatous Disease Cooperative Study Group. *N Engl J Med* 1991;324:509–16.
  63. van den Berg JM, van Koppen E, Ahlin A, Belohradsky BH, Bernatowska E, Corbeel L, et al. Chronic granulomatous disease: the European experience. *PLoS ONE* 2009;4:e5234.
  64. Feld JJ, Hussain N, Wright EC, Kleiner DE, Hoofnagle JH, Ahlawat S, et al. Hepatic involvement and portal hypertension predict mortality in chronic granulomatous disease. *Gastroenterology* 2008;134:1917–26.
  65. Gungor T, Teira P, Slatter M, Stussi G, Stepensky P, Moshous D, et al. Reduced-intensity conditioning and HLA-matched haemopoietic stem-cell transplantation in patients with chronic granulomatous disease: a prospective multicentre study. *Lancet* 2014;383:436–48.
  66. Ott MG, Seger R, Stein S, Siler U, Hoelzer D, Grez M. Advances in the treatment of Chronic Granulomatous Disease by gene therapy. *Curr Gene Ther* 2007;7:155–61.
  67. Kang EM, Choi U, Theobald N, Linton G, Long Priel DA, Kuhns D, et al. Retrovirus gene therapy for X-linked chronic granulomatous disease can achieve stable long-term correction of oxidase activity in peripheral blood neutrophils. *Blood* 2010;115:783–91.
  68. Bianchi M, Hakkim A, Brinkmann V, Siler U, Seger RA, Zychlinsky A, et al. Restoration of NET formation by gene therapy in CGD controls aspergillosis. *Blood* 2009;114:2619–22.
  69. Kang EM, Malech HL. Gene therapy for chronic granulomatous disease. *Methods Enzymol* 2012;507:125–54.
  70. Nauseef WM. Myeloperoxidase deficiency. *Hematol Oncol Clin North Am* 1988;2:135–58.
  71. Okuda T, Yasuoka T, Oka N. Myeloperoxidase deficiency as a predisposing factor for deep mucocutaneous candidiasis: a case report. *J Oral Maxillofac Surg* 1991;49:183–6.
  72. Ludviksson BR, Thorarensen O, Gudnason T, Halldorsson S. Candida albicans meningitis in a child with myeloperoxidase deficiency. *Pediatr Infect Dis J* 1993;12:162–4.
  73. Nguyen C, Katner HP. Myeloperoxidase deficiency manifesting as pustular candidal dermatitis. *Clin Infect Dis* 1997;24:258–60.
  74. Chiang AK, Chan GC, Ma SK, Ng YK, Ha SY, Lau YL. Disseminated fungal infection associated with myeloperoxidase deficiency in a premature neonate. *Pediatr Infect Dis J* 2000;19:1027–9.
  75. Notarangelo LD, Badolato R. Leukocyte trafficking in primary immunodeficiencies. *J Leukoc Biol* 2009;85:335–43.
  76. Anderson DC, Schmalsteig FC, Finegold MJ, Hughes BJ, Rothlein R, Miller LJ, et al. The severe and moderate phenotypes of heritable Mac-1, LFA-1 deficiency: their quantitative definition and relation to leukocyte dysfunction and clinical features. *J Infect Dis* 1985;152:668–89.
  77. Kuijpers TW, Van Lier RA, Hamann D, de Boer M, Thung LY, Weening RS, et al. Leukocyte adhesion deficiency type 1 (LAD-1)/variant. A novel immunodeficiency syndrome characterized by dysfunctional beta2 integrins. *J Clin Invest* 1997;100:1725–33.
  78. Uzel G, Tng E, Rosenzweig SD, Hsu AP, Shaw JM, Horwitz ME, et al. Reversion mutations in patients with leukocyte adhesion deficiency type-1 (LAD-1). *Blood* 2008;111:209–18.
  79. Thomas C, Le Deist F, Cavazzana-Calvo M, Benkerrou M, Haddad E, Blanche S, et al. Results of allogeneic bone marrow transplantation in patients with leukocyte adhesion deficiency. *Blood* 1995;86:1629–35.
  80. Bauer TR Jr, Gu YC, Creevy KE, Tuschong LM, Embree L, Holland SM, et al. Leukocyte adhesion deficiency in children and Irish setter dogs. *Pediatr Res* 2004;55:363–7.
  81. Lubke T, Marquardt T, Etzioni A, Hartmann E, von Figura K, Korner C. Complementation cloning identifies CDG-IIc, a new type of congenital disorders of glycosylation, as a GDP-fucose transporter deficiency. *Nat Genet* 2001;28:73–6.
  82. Luhn K, Wild MK, Eckhardt M, Gerardy-Schahn R, Vestweber D. The gene defective in leukocyte adhesion deficiency II encodes a putative GDP-fucose transporter. *Nat Genet* 2001;28:69–72.
  83. Mory A, Feigelson SW, Yarali N, Kilic SS, Bayhan GI, Gershoni-Baruch R, et al. Kindlin-3: a new gene involved in the pathogenesis of LAD-III. *Blood* 2008;112:2591.
  84. Kuijpers TW, van de Vijver E, Weterman MA, de Boer M, Tool AT, van den Berg TK, et al. LAD-1/variant syndrome is caused by mutations in FERMT3. *Blood* 2009;113:4740–6.
  85. Etzioni A, Gershoni-Baruch R, Pollack S, Shehadeh N. Leukocyte adhesion deficiency type II: long-term follow-up. *J Allergy Clin Immunol* 1998;102:323–4.
  86. Marquardt T, Luhn K, Srikrishna G, Freeze HH, Harms E, Vestweber D. Correction of leukocyte adhesion deficiency type II with oral fucose. *Blood* 1999;94:3976–85.
  87. Etzioni A, Tonetti M. Fucose supplementation in leukocyte adhesion deficiency type II. *Blood* 2000;95:3641–3.
  88. Ambruso DR, Knall C, Abell AN, Panepinto J, Kurkchubasche A, Thurman G, et al. Human neutrophil immunodeficiency syndrome is associated with an inhibitory Rac2 mutation. *Proc Natl Acad Sci U S A* 2000;97:4654–9.
  89. Williams DA, Tao W, Yang F, Kim C, Gu Y, Mansfield P, et al. Dominant negative mutation of the hematopoietic-specific Rho GTPase, Rac2, is associated with a human phagocyte immunodeficiency. *Blood* 2000;96:1646–54.
  90. Accetta D, Syverson G, Bonacci B, Reddy S, Bengtson C, Surfus J, et al. Human phagocyte defect caused by a Rac2 mutation detected by means of neonatal screening for T-cell lymphopenia. *J Allergy Clin Immunol* 2011;127:535–8, e1–2.
  91. Bresnick EH, Katsumura KR, Lee HY, Johnson KD, Perkins AS. Master regulatory GATA transcription factors: mechanistic principles and emerging links to hematologic malignancies. *Nucleic Acids Res* 2012;40:5819–31.
  92. Hambleton S, Salem S, Bustamante J, Bigley V, Boisson-Dupuis S, Azevedo J, et al. IRF8 mutations and human dendritic-cell immunodeficiency. *N Engl J Med* 2011;365:127–38.
  93. Bogunovic D, Byun M, Durfee LA, Abhyankar A, Sanal O, Mansouri D, et al. Mycobacterial disease and impaired IFN-gamma immunity in humans with inherited ISG15 deficiency. *Science* 2012;337:1684–8.
  94. McDonald DR, Janssen R, Geha R. Lessons learned from molecular defects in nuclear factor kappaB dependent signaling. *Microbes infect* 2006;8:1151–6.
  95. Haverkamp MH, van Dissel JT, Holland SM. Human host genetic factors in nontuberculous mycobacterial infection: lessons from single gene disorders affecting innate and adaptive immunity and lessons from molecular defects in interferon-gamma-dependent signaling. *Microbes infect* 2006;8:1157–66.
  96. Al-Muhsen S, Casanova JL. The genetic heterogeneity of Mendelian susceptibility to

- mycobacterial diseases. *J Allergy Clin Immunol* 2008;122:1043–51, quiz 1052–3.
97. Bustamante J, Arias AA, Vogt G, Picard C, Galicia LB, Prando C, et al. Germline CYBB mutations that selectively affect macrophages in kindreds with X-linked predisposition to tuberculous mycobacterial disease. *Nat Immunol* 2011;12:213–21.
  98. Spinner MA, Sanchez LA, Hsu AP, Shaw PA, Zerbe CS, Calvo KR, et al. GATA2 deficiency: a protean disorder of hematopoiesis, lymphatics, and immunity. *Blood* 2014;123:809–21.
  99. Fieschi C, Dupuis S, Catherinot E, Feinberg J, Bustamante J, Breiman A, et al. Low penetrance, broad resistance, and favorable outcome of interleukin 12 receptor beta1 deficiency: medical and immunological implications. *J Exp Med* 2003;197:527–35.
  100. Hanson EP, Monaco-Shawver L, Solt LA, Madge LA, Banerjee PP, May MJ, et al. Hypomorphic nuclear factor-kappaB essential modulator mutation database and reconstitution system identifies phenotypic and immunologic diversity. *J Allergy Clin Immunol* 2008;122:1169–77, e1116.
  101. Smahi A, Courtois G, Vabres P, Yamaoka S, Heuertz S, Munnich A, et al. Genomic rearrangement in NEMO impairs NF-kappaB activation and is a cause of incontinentia pigmenti. The International Incontinentia Pigmenti (IP) Consortium. *Nature* 2000;405:466–72.
  102. Jouanguy E, Lamhamedi-Cherradi S, Lammas D, Dorman SE, Fondanèche MC, Dupuis S, et al. A human IFNGR1 small deletion hotspot associated with dominant susceptibility to mycobacterial infection. *Nat Genet* 1999;21:370–8.
  103. Fleisher TA, Dorman SE, Anderson JA, Vail M, Brown MR, Holland SM. Detection of intracellular phosphorylated STAT-1 by flow cytometry. *Clin Immunol* 1999;90:425–30.
  104. Uzel G, Frucht DM, Fleisher TA, Holland SM. Detection of intracellular phosphorylated STAT-4 by flow cytometry. *Clin Immunol* 2001;100:270–6.
  105. de Beaucoudrey L, Samarina A, Bustamante J, Cobat A, Boisson-Dupuis S, Feinberg J, et al. Revisiting human IL-12Rbeta1 deficiency: a survey of 141 patients from 30 countries. *Medicine* 2010;89:381–402.
  106. Grimbacher B, Holland SM, Gallin JJ, Greenberg F, Hill SC, Malech HL, et al. Hyper-IgE syndrome with recurrent infections—an autosomal dominant multisystem disorder. *N Engl J Med* 1999;340:692–702.
  107. Minegishi Y, Saito M, Tsuchiya S, Tsuge I, Takada H, Hara T, et al. Dominant-negative mutations in the DNA-binding domain of STAT3 cause hyper-IgE syndrome. *Nature* 2007;448:1058–62.
  108. Holland SM, DeLeo FR, Elloumi HZ, Hsu AP, Uzel G, Brodsky N, et al. STAT3 mutations in the hyper-IgE syndrome. *N Engl J Med* 2007;357:1608–19.
  109. Freeman AF, Renner ED, Henderson C, Langenbeck A, Olivier KN, Hsu AP, et al. Lung parenchyma surgery in autosomal dominant hyper-IgE syndrome. *J Clin Immunol* 2013;33:896–902.
  110. Freeman AF, Holland SM. The hyper-IgE syndromes. *Immunol Allergy Clin North Am* 2008;28:277–91, viii.
  111. Ling JC, Freeman AF, Gharib AM, Arai AE, Lederman RJ, Rosing DR, et al. Coronary artery aneurysms in patients with hyper IgE recurrent infection syndrome. *Clin Immunol* 2007;122:255–8.
  112. Freeman AF, Collura-Burke CJ, Patronas NJ, Ilcus LS, Darnell D, Davis J, et al. Brain abnormalities in patients with hyperimmunoglobulin E syndrome. *Pediatrics* 2007;119:e1121–5.
  113. Leonard GD, Posadas E, Herrmann PC, Anderson VL, Jaffe ES, Holland SM, et al. Non-Hodgkin's lymphoma in Job's syndrome: a case report and literature review. *Leuk Lymphoma* 2004;45:2521–5.
  114. Renner ED, Puck JM, Holland SM, Schmitt M, Weiss M, Frosch M, et al. Autosomal recessive hyperimmunoglobulin E syndrome: a distinct disease entity. *J Pediatr* 2004;144:93–9.
  115. Engelhardt KR, McGhee S, Winkler S, Sassi A, Woellner C, Lopez-Herrera G, et al. Large deletions and point mutations involving the dedicator of cytokinesis 8 (DOCK8) in the autosomal-recessive form of hyper-IgE syndrome. *J Allergy Clin Immunol* 2009;124:1289–302, e1284.
  116. Zhang Q, Davis JC, Lamborn IT, Freeman AF, Jing H, Favreau AJ, et al. Combined immunodeficiency associated with DOCK8 mutations. *N Engl J Med* 2009;361:2046–55.
  117. Minegishi Y, Saito M, Morio T, Watanabe K, Agematsu K, Tsuchiya S, et al. Human tyrosine kinase 2 deficiency reveals its requisite roles in multiple cytokine signals involved in innate and acquired immunity. *Immunity* 2006;25:745–55.
  118. Kilic SS, Hacimustafaoglu M, Boisson-Dupuis S, Kreins AY, Grant AV, Abel L, et al. A patient with tyrosine kinase 2 deficiency without hyper-IgE syndrome. *J Pediatr* 2012;160:1055–7.
  119. Puel A, Cypowyj S, Marodi L, Abel L, Picard C, Casanova JL. Inborn errors of human IL-17 immunity underlie chronic mucocutaneous candidiasis. *Curr Opin Allergy Clin Immunol* 2012;12:616–22.
  120. Netea MG, Brown GD, Kullberg BJ, Gow NA. An integrated model of the recognition of *Candida albicans* by the innate immune system. *Nat Rev Microbiol* 2008;6:67–8.
  121. Ferwerda B, Ferwerda G, Plantinga TS, Willment JA, van Spruel AB, Venselaar H, et al. Human dectin-1 deficiency and mucocutaneous fungal infections. *N Engl J Med* 2009;361:1760–7.
  122. van de Veerdonk FL, Plantinga TS, Hoischen A, Smeekens SP, Joosten LA, Gilissen C, et al. STAT1 mutations in autosomal dominant chronic mucocutaneous candidiasis. *N Engl J Med* 2011;365:54–61.
  123. Liu L, Okada S, Kong XF, Kreins AY, Cypowyj S, Abhyankar A, et al. Gain-of-function human STAT1 mutations impair IL-17 immunity and underlie chronic mucocutaneous candidiasis. *J Exp Med* 2011;208:1635–48.
  124. Lanternier F, Pathan S, Vincent QB, Liu L, Cypowyj S, Prando C, et al. Deep dermatophytosis and inherited CARD9 deficiency. *N Engl J Med* 2013;369:1704–14.
  125. Sampaio EP, Hsu AP, Pechacek J, Bax HI, Dias DL, Paulson ML, et al. Signal transducer and activator of transcription 1 (STAT1) gain-of-function mutations and disseminated coccidioidomycosis and histoplasmosis. *J Allergy Clin Immunol* 2013;131:1624–34.

# Rheumatic Diseases of Childhood: Therapeutic Principles

ROBERT P. SUNDEL

## KEY POINTS

- Rheumatologic disorders are perpetuated by ongoing immune activation resulting from failure to clear triggering antigens combined with aberrant control mechanisms.
- The resulting chronic inflammation leads to local granuloma formation, scarring and fibrosis, as well as systemic symptoms such as fever, malaise, disrupted growth and elevated acute-phase reactants.
- Rheumatologic diseases are monitored by physical and laboratory examination of specific and nonspecific effects on involved organ systems.
- Early, aggressive therapy is aimed at preventing irreversible tissue damage and minimizing immunologic evasion of medication efficacy through epitope spreading and antibody affinity maturation.
- Therapy is seldom curative, so chronic treatment must be guided by optimizing medication benefits and minimizing their risks, especially those related to immunosuppression.
- The expanding therapeutic armamentarium against rheumatologic diseases is improving outcomes by targeting of pathogenic cells and cytokines using biologic response modifiers and small molecule inhibitors.
- Specific approaches to the most common pediatric rheumatologic disorders – juvenile arthritis, systemic lupus erythematosus and dermatomyositis – include agents providing symptomatic relief as well as more potent antiinflammatory and immunosuppressive disease modifying agents.

‘Rheumatology’ derives from the Greek word *rheuma*, meaning ‘river’ or ‘flow’. It reflects the ancient belief that articular pain is caused by the settling of bad humors in the joints. In the almost two millennia since Galen introduced this term, understanding of how arthritis and related maladies develop has changed dramatically. What has not changed, however, is the broad spectrum of conditions falling within the purview of rheumatology.

Rheumatologic disorders are often equated with autoimmunity. In fact, while the former term is overly general and imprecise, the latter implies that we know more about the pathogenesis of these conditions than we really do. Most chronic inflammatory disorders are indeed marked by ongoing immune activation, but it is not clear that the process is either initiated or perpetuated by autoreactivity. Even where this may be the

case, such as diseases marked by self-reacting lymphocytes or autoantibodies, an autoantigen is seldom identified. At the very least, exogenous factors such as infection or injury are often central to disease development. Accordingly, this chapter will focus on the most common pediatric inflammatory diseases, but it will stress the inflammatory and immunologic factors relevant to their diagnosis and treatment, rather than theoretical aspects of tolerance and self-recognition. The newest family of inflammatory disorders, autoinflammatory diseases, is addressed in Chapter 14, and connective tissue diseases and pain syndromes are not addressed because their care is driven more by empirical clinical experience than by immunologic principles.

## Inflammation

Inflammation is the way the body reacts to infection, injury or irritation.<sup>1</sup> Although its cardinal signs – *dolor, calor, rubor* and *tumor* – are stereotypical and recognizable, the process itself is complex and protean. Further, the inflammatory response must operate within very tight constraints. It must have a rapid onset of action, lest an invading organism proliferate overwhelmingly before control is achieved. It must be restricted physically in order to minimize damage to distant, uninvolved tissues. And it must be limited temporally so that ongoing tissue destruction does not progress after the inciting trigger resolves. In view of the difficulty of achieving such tight regulation, it is not surprising that harmful pathology is a not-infrequent side-effect of inflammation.

Inflammation associated with rheumatologic diseases typically involves both the innate and the adaptive immune systems. Initially, cells at the point of contact with foreign antigens or disrupted tissue are activated when they recognize pathogen-associated molecular patterns (PAMPs) that are generally not present on normal host cells. Pattern recognition receptors on macrophages and dendritic cells lead to cellular activation and release of intercellular mediators, resulting in the manifestations of inflammation. Thus, complement breakdown products and bradykinin augment regional blood flow by dilating local vessels, leading to warmth and redness. These and other chemicals also cause pain and swelling and increase vascular permeability, allowing proteins to exude into local tissues. These substances, in turn, attract phagocytes and stimulate degranulation, releasing additional inflammatory mediators including chemokines and cytokines, attracting and activating lymphocytes and recruiting components of the adaptive immune system.

Among the cytokines most important to the inflammatory response are IL-1, IL-6 and TNF- $\alpha$ , which together are responsible for many of the characteristic systemic signs and

symptoms including fever, anorexia and malaise. These cytokines also elicit the hepatic acute-phase response, down-regulating so-called 'housekeeping proteins' such as albumin and up-regulating synthesis of mediators of 'fight and flight' such as C-reactive protein (CRP, an opsonin for certain organisms), fibrinogen (facilitator of blood clotting) and ferritin (which deprives bacteria of free iron) (Figure 12-1).

Another important class of inflammatory mediators is the arachidonic acid metabolites, including leukotrienes and prostaglandins. Released by inflammatory cells, these mediators contribute to acute erythema and swelling by inducing vasodilation and capillary leak. Prostaglandin  $E_2$  is of particular importance because it also sensitizes local nerve endings to pain and, with IL-1, mediates fever via effects on the hypothalamus.

As important as the initiation and augmentation of the inflammatory response may be, its timely disengagement and resolution are at least as essential for good health.<sup>2</sup> Much of this restoration of normal homeostasis is passive, a consequence of the short half-life of most inflammatory mediators. In addition, active controls are involved, such as antiinflammatory cytokines (e.g. IL-10) and antiinflammatory molecules (e.g. soluble TNF receptor, IL-1 receptor antagonist and resolvins). Finally, the disappearance of perpetuating mediators starves activated cells of essential growth factors, leading to programmed death (apoptosis) of accumulated inflammatory cells. In most situations, these controls are sufficient to allow the inflammatory

response to fade and for damage to be repaired through healing, fibrosis and scarring.

Rheumatologic disorders are typically chronic conditions in which the usual control mechanisms fail to stem the inflammatory response. Many factors may lead to such ongoing inflammation. For example, the stimulus triggering inflammation may be recurrent or impossible to eliminate (i.e. uric acid crystals in gout or a modified self-antigen in diabetes). In the majority of rheumatologic diseases, however, the cause is not clear, with neither the triggering stimulus nor potential aberrations in control mechanisms fully understood. In such cases, persistent inflammation may result in granuloma formation, scarring and/or fibrosis locally, as well as malaise, fever, anorexia, weight loss and elevation of acute-phase reactants systemically. While the specific manifestations of various rheumatologic conditions vary, these hallmarks are typical of all forms of systemic inflammation.

### Assessing Systemic Inflammation

As noted, cytokines and other mediators released by immune cells account for the clinical picture of systemic inflammation. Another clinical manifestation of inflammation is stunting of growth, apparently as a result of interference with normal anabolic hormones even in the setting of adequate dietary intake. The onset of a chronic inflammatory disease often can be pinpointed by careful review of the growth chart.

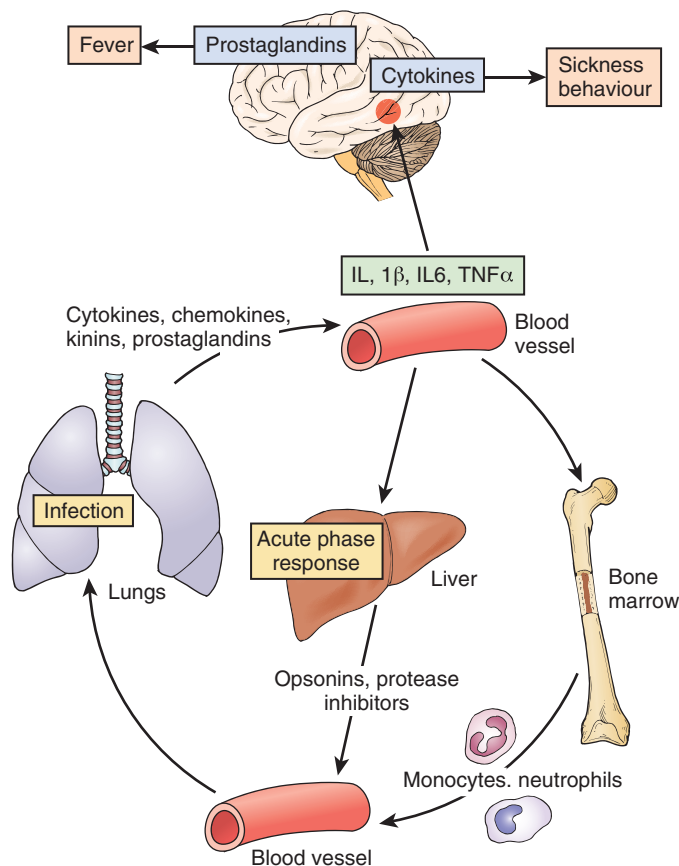

**Figure 12-1** Hepatic acute-phase response ([http://www.nature.com/nrn/journal/v4/n2/fig\\_tab/nrn1032\\_F2.html](http://www.nature.com/nrn/journal/v4/n2/fig_tab/nrn1032_F2.html)).



The blood tests most often used to assess the degree of systemic inflammation are the erythrocyte sedimentation rate (ESR) and the CRP.<sup>3</sup> CRP is a product of the hepatic acute-phase response and rises within 48 hours of an inflammatory stimulus (Figure 12-2).<sup>4</sup> An elevated ESR is a rapidly quantifiable physical manifestation of elevation of a variety of acute-phase reactants, especially fibrinogen. This and other positively charged proteins tend to intercalate between negatively charged erythrocytes, facilitating the formation of red blood cell stacks (rouleaux) that sediment more rapidly than free-floating cells. Since the levels of these proteins take days to weeks to respond to an inflammatory stimulus, the ESR rises more slowly than the CRP in acute inflammation and remains elevated longer after the inflammation resolves. Nevertheless, ready availability and extensive experience with the ESR make it a useful, if non-specific, clinical tool.

Humoral mediators are responsible for many other manifestations of acute inflammation such as leukocytosis, appearance of immature ('band') forms of white blood cells, and thrombocytosis. In addition, prolonged inflammation typically causes normocytic anemia (the anemia of chronic disease) and, in response to some inflammatory stimuli, elevated levels of serum immunoglobulins from B cell stimulation.

## Principles of Antiinflammatory Therapy (Box 12-1)

Ideal therapy would target only aberrant manifestations of the inflammatory response while preserving basic regulatory and effector functions of immunity. Unfortunately, the aberration in the immune system responsible for specific inflammatory diseases is generally unknown, available agents do not distinguish between harmful and beneficial immune activity, and many drugs also have nonimmunologic side-effects. The result is that the risks of immune suppression are often considerable,

and they must be balanced against the benefits of controlling inflammation when deciding upon therapy. Practical aspects of these considerations generally follow several basic principles:

1. *The least toxic medications should be used for the briefest period of time.* Unfortunately, most rheumatologic disorders are managed without expectation of cure. For unknown reasons, varying percentages of different conditions will remit over time, but rarely can such remissions be ascribed to the effects of treatment. At best, conditions may be stabilized as inflammation is controlled, ultimately minimizing the need for continuous immunosuppression. Thus, with antiinflammatory therapy likely to be needed indefinitely, minimizing the amount and intensity of antiinflammatory treatments is essential for avoiding complications due to effects on tumor surveillance and resistance to infections. While such risks are increased by combination immunosuppression, particularly the addition of steroids to other agents, in many cases disease activity also contributes to a patient's risk of developing opportunistic infections and malignancies. Thus, managing rheumatologic diseases remains very much an art rather than a science.

### BOX 12-1 PRINCIPLES OF ANTIINFLAMMATORY THERAPY

1. The least toxic medications should be used for the briefest period of time.
2. Early, aggressive therapy offers the greatest chance of achieving a good outcome:
  - a. Irreversible damage, which occurs early in the disease course, is avoided
  - b. Evolution of the immune response increases resistance to therapy over time.
3. The uniqueness of the individual immune response necessitates a 'treat to target' approach.

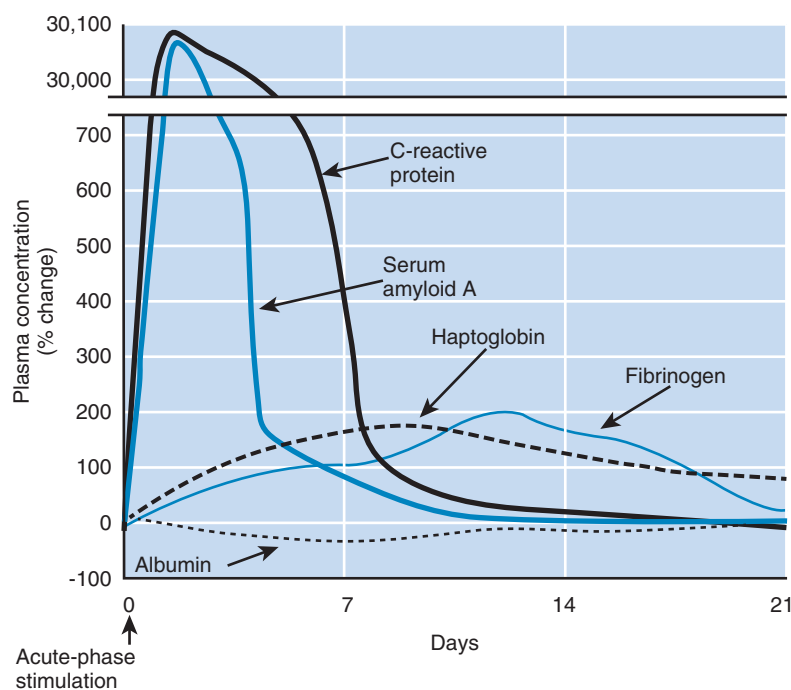

Figure 12-2 Time course of the acute-phase response.

2. *Early, aggressive therapy offers the greatest chance of achieving a good outcome:*
  - a. Rheumatologic disorders not only cause inflammation and the signs and symptoms with which it is associated, but over time they tend to cause irreversible tissue damage as well. While such damage occurs at varying rates in different conditions and different individuals, achieving disease control rapidly enough to avoid such damage is generally the best way to avoid chronic ill-effects of rheumatologic disorders. Often such damage occurs early in the disease course – for example, up to 50% of people with rheumatoid arthritis develop erosive changes within two years of disease onset.<sup>5</sup> As a result, earlier ideas of gradual intensification of therapy (the so-called ‘reverse pyramid’) have fallen out of favor. Instead, early initiation of optimally effective treatment, with subsequent tapering once disease control is achieved, is now preferred.
  - b. The centrality of involvement of the immune system in the pathogenesis of rheumatologic disorders means that disease activity is not static. Rather, as long as a tissue is being targeted, the immune system is evolving to optimize the inflammatory attack. Affinity and avidity of antibodies increase over time (affinity maturation), and target epitopes are honed and extended (epitope spreading) to minimize immune evasion due to antigenic variation. Thus, there may be a ‘window of opportunity’ early in the course of inflammatory disorders during which autoimmunity may be controlled.<sup>6</sup> Over time, however, with broadening of the inflammatory response, such restoration of regulation may become increasingly difficult and require progressively more intense immunosuppression.
3. *The complexity and unpredictability of the immune process driving inflammation in rheumatologic disorders necessitates an individualized approach to therapy.* The many factors involved in the initiation and perpetuation of rheumatologic conditions – including host genetic and epigenetic factors, co-morbid medical conditions, variations in triggering events, and pharmacogenetic idiosyncrasies affecting response to medications – do not lend themselves to standardized protocols of treatment. Rather, the concept of ‘treat to target’ is now the preferred paradigm: therapeutic response is measured on an ongoing basis, and types and doses of medications are adjusted based on a patient’s response rather than being continued for an arbitrary period of time before changes are made. No single approach is universally effective in all patients, and not all therapeutic regimens are equally beneficial. Thus careful monitoring as well as thorough familiarity with both theoretical and experimental effects of treatments are necessary to optimally treat rheumatologic conditions.

With these principles as a background, a general overview of the current panoply of antiinflammatory agents is offered below.<sup>7</sup> Following that is a discussion of the most common pediatric rheumatologic conditions, including specific information on their diagnosis and natural history, and empirical approaches to treatment.

## Therapeutic Strategies (Box 12-2)

Inadequate understanding of fundamental disease mechanisms has limited treatment options for rheumatologic diseases. Since

### BOX 12-2 ANTIINFLAMMATORY AGENTS (IN APPROXIMATE ORDER OF INCREASING POTENCY)

1. Inhibitors of arachidonic acid metabolism
  - a. Nonsteroidal antiinflammatory drugs (NSAIDs)
  - b. Cyclooxygenase (COX)-2 inhibitors
2. Immunomodulators
  - a. Disease-modifying antirheumatic drugs (DMARDs)
  - b. Calcineurin inhibitors
3. Targeted molecular therapies
  - a. Monoclonal antibodies
    - i. Cytokines
    - ii. Costimulatory molecules
  - b. Receptor antagonists
  - c. Small molecules
    - i. Protease inhibitors
    - ii. Interfering RNA
4. Immunosuppressants
  - a. Antimetabolites
  - b. Cytotoxic agents
  - c. Corticosteroids
5. Immune reconstitution
  - a. Stem cell transplant
  - b. Bone marrow transplant

the initial use of corticosteroids almost 60 years ago, clinicians could offer little more than broad immunosuppression plus supportive care (e.g. physical therapy for rheumatoid arthritis) to mitigate end-organ damage. More recently, rapid advances in molecular immunology have brought us tantalizingly near to the Holy Grail of immunomodulation – the possibility of targeting only disease-mediating cells, leaving other facets of immunity unaffected. Although this possibility remains largely theoretical, new targeted approaches for reducing long-term disability and total exposure to immunosuppressive therapy are improving quality of life and long-term outcomes faster than ever before.<sup>8</sup>

## SYSTEMIC IMMUNOSUPPRESSION

The mainstay of treatment for systemic rheumatologic diseases remains immunosuppressive medications. These ameliorate the clinical and serologic effects of disease activity by targeting effectors of the immune response. Adverse effects of immunosuppression result from interference with protective immunity as well as pathologic autoimmunity and include the ongoing risk of infection and the cumulative potential for developing a malignancy due to diminished immune surveillance.

Corticosteroids, perhaps the least discriminating tool in the armamentarium, are used in doses ranging from daily low-dose oral regimens to ‘pulsed’ high-dose intravenous therapy. Traditional disease-modifying antirheumatic drugs (DMARDs) such as methotrexate, leflunomide, hydroxychloroquine and sulfasalazine are mildly immunosuppressive and cause minimally increased risks of infection. Their benefits are likely mediated through antiinflammatory and immunomodulatory effects rather than through immunosuppression per se. More potent immunosuppressive agents such as azathioprine, cyclosporin A, mycophenolate mofetil and cyclophosphamide are often necessary for treating more severe conditions such as vasculitis and systemic lupus erythematosus (SLE).

Plasmapheresis is an important treatment utilized to remove pathogenic antibodies and other humoral factors from the

circulation.<sup>9</sup> It is employed when urgent measures are needed to stabilize a patient before longer-term interventions take effect, for example cases of acute hemorrhage from the pulmonary-renal syndromes, granulomatosis with polyangiitis (Wegener's granulomatosis) and Goodpasture syndrome. Intravenous immunoglobulin (IVIG) has immunomodulatory properties without the risks of immunosuppression, particularly useful in patients whose inflammatory condition is a result of an immunodeficiency (e.g. granulomatous common variable immunodeficiency).<sup>10</sup> Inexplicably, IVIG is superior to any other therapy in arresting acute inflammation and preventing target-organ damage in cases of Kawasaki disease, an inflammatory vasculitis of childhood.<sup>11</sup> While IVIG can also remove activated complement fragments that mediate inflammation in dermatomyositis, its role in other inflammatory disorders is far less prominent.

### TARGETED MOLECULAR THERAPIES

During the past decade, a new generation of drugs targeting cytokines and lymphocyte receptors has dramatically altered the therapeutic landscape of rheumatology.<sup>12</sup> These so-called 'biologic response modifiers' (BRMs) are recombinant monoclonal antibodies and receptor antagonists that inhibit specific targets.<sup>13</sup> The impact of BRMs is perhaps most clearly evidenced by the fact that, as of 2007, eight of the 20 best-selling biotechnology drugs in the USA were therapeutic monoclonal antibodies.<sup>14</sup> Biologic drugs are discussed further in Chapter 17.

### NOVEL THERAPEUTIC TARGETS

Novel targeted therapies for autoimmune diseases will broaden attempts to exploit cytokines and lymphocyte cell surface molecules involved in mediating inflammation and lymphocyte activation. Not only monoclonal antibodies but small molecule inhibitors and interfering RNA are being investigated.<sup>15</sup> The first such agent approved for a rheumatologic indication was tofacitinib, a Janus kinase (JAK) inhibitor, which was approved for treatment of rheumatoid arthritis in 2012. Protein kinase inhibitors interfere with phosphorylation of serine, threonine or tyrosine residues in proteins. This step is needed for proliferation or activation, so inhibitors of protein kinases may have therapeutic effects in rheumatologic and malignant disorders. Such agents are immunosuppressive and so risk of infections remains a serious concern, as with biologic agents. Their major advantage at present is the fact that they are not digested by enzymes of the gastrointestinal tract so they may be taken orally, unlike monoclonal antibodies.

Small molecule protein kinase inhibitors developed for the treatment of malignancies may have utility in autoimmune diseases. For example, patients with systemic sclerosis (SSc) demonstrate increased activity of the platelet derived growth factor receptor (PDGFR), possibly due to stimulatory autoantibodies. Studies have focused attention on imatinib (Gleevec®), a drug that inhibits multiple tyrosine kinases including PDGFR, as a possible therapy for SSc.<sup>16</sup> This kinase inhibitor has already had dramatic effects on the treatment of chronic myelogenous leukemia and gastrointestinal stromal tumors.

Proteasome inhibition and pharmacologic regulation of autophagy, a cellular recycling pathway in which cellular targets are delivered to lysosomes for degradation, represent additional autoimmune disease targets of interest. Bortezomib,

a proteasome inhibitor approved for the treatment of multiple myeloma, inhibits degradation of pro-apoptotic factors, permitting activation of programmed cell death in rapidly dividing cells. This leads to depletion of short- and long-lived plasma cells and reduces autoantibody production, a possible explanation for the ability of bortezomib to protect lupus-prone mouse strains from the development of nephritis.<sup>17</sup> Hydroxychloroquine, a drug used to treat malaria for more than half a century, also blocks acidification of phagolysosomes. It is known to prolong remissions in SLE and may exert beneficial effects in other autoimmune diseases by modulating autophagy-mediated antigen presentation.<sup>18</sup> Future work may lead to therapies that capitalize on immune cell requirements for cellular recycling and unfolded protein response pathways in order to inhibit autoreactive responses without causing significant immunosuppression.

The ultimate approach to therapy of intractable immune activation or immune dysregulation is 'resetting' of the immune system in an attempt to restore normal regulatory controls.<sup>19</sup> Treatment of severe autoimmunity with stem cell transplantation remains experimental, largely because of the significant morbidity and mortality that still accompany this approach. Nonetheless, this approach has been used in cases of severe systemic juvenile rheumatoid arthritis (JRA), SSc, and SLE resistant to conventional therapy. For example, a recent report documented sustained clinical remission in seven patients with severe refractory SLE treated with immunoablation and autologous hematopoietic stem cell transplantation. Further, after transplantation, the patients demonstrated evidence of normalization of naive lymphocyte populations and generation of thymic derived regulatory T cells.<sup>20</sup> Safer methods for reconstituting the bone marrow compartment, such as autologous stem cell reconstitution protocols, could provide a therapeutic alternative for the most difficult to treat patients.

## Approaches to Specific Conditions

The final section of this chapter addresses specific therapeutic approaches to the three most common pediatric rheumatologic disorders. This represents a snapshot of a rapidly evolving discipline. Each new biologic agent or small molecule inhibitor has the potential to disrupt the existing paradigm by introducing dramatic improvements in the therapeutic risk-benefit ratio. The rapidity of such changes cannot be overstated. For example, within the past 15 years identification of the genetic basis of familial Mediterranean fever led to the description of an entire new class of disorders, the autoinflammatory conditions. In short order, this was followed by the introduction of biologic therapy as an almost miraculous, specific approach to conditions that had previously been untreatable, debilitating and often fatal. In view of this unprecedented rate of change, clinicians caring for children with rheumatologic conditions require guidelines to help navigate the rapidly expanding and increasingly complex rheumatologic armamentarium. These are offered below.

### JUVENILE IDIOPATHIC ARTHRITIS (JIA)

Juvenile arthritis is the most common rheumatologic disorder of childhood, affecting as many as one in 1,000 children under the age of 16 years. From the first published case of arthritis developing in a child in 1864, descriptions have tended to

include a variety of patterns that likely represent numerous different subtypes of juvenile arthritis.<sup>21</sup>

Unfortunately, with the pathogenesis of juvenile arthritis poorly understood, most classification schemes have categorized patients based on the number and pattern of joints involved, the populations being studied and the interests of the committee members categorizing them. Not surprisingly, genetic and immunologic data demonstrate significant overlap and imprecision when classification is based solely on such phenotypic patterns. Current classifications thus leave much room for improvement.<sup>22</sup> Nonetheless, whether a child is said to have psoriatic arthritis (based on the 1977 criteria of the International Leagues of Associations for Rheumatology), pauciarticular juvenile rheumatoid arthritis (based on the 1986 American College of Rheumatology criteria) or enthesitis-related arthritis (according to the 1993 International League of Associations for Rheumatology proposed classification of the idiopathic arthritides of childhood), management and therapy are largely similar across classification systems and disease subtypes.

### *Pauciarthritis*

Arthritis involving fewer than five joints, known as oligoarticular or pauciarticular arthritis, is the most common form. The knee is most often affected, followed by the ankle, wrist and elbow. There are two peaks of onset: one between the ages of 1 and 5 years and the other between 12 and 16 years. Most patients present with a gradual onset of stiffness, swelling and diminished mobility, most prominent early in the day or after prolonged inactivity.

The extent to which children complain of pain varies, with younger children often limping but denying discomfort.

The degree of debility caused by arthritis is generally proportional to the number of joints involved. Pauciarthritis usually does not cause systemic symptoms such as fatigue, malaise, fevers or significant elevation of acute-phase reactants. Involved joints may grow more rapidly, however, due to increased blood flow and nutrient delivery to inflamed tissues, so asymmetric involvement persisting for more than a few months may lead to limb-length discrepancies and significant muscle atrophy.

In addition, pauciarthritis is associated with a significantly increased risk of developing chronic, asymptomatic anterior uveitis.<sup>23</sup> This occurs in up to 30% of children with pauciarthritis who are antinuclear antibody (ANA) positive, with up to one third of children diagnosed with anterior chamber inflammation before arthritis develops. About 50% of children with uveitis develop it roughly coincident with the onset of arthritis; onset more than 7 years after the diagnosis of arthritis is very rare. Early detection of the uveitis is important in preventing sequelae; 20% or more of those in whom diagnosis is delayed develop decreased visual acuity or even blindness. Unfortunately, chronic anterior uveitis is usually asymptomatic, so children with pauciarticular JIA should have slit lamp examinations by a pediatric ophthalmologist on a regular basis so that undetected inflammation does not cause irreversible ocular changes.

### *Polyarthritis*

Polyarthritis affects five or more joints, both large and small, though typically in a symmetric pattern. Diagnosis requires clear evidence of joint inflammation (decreased function, swelling, stiffness and/or warmth), not merely pain. It is thus important to

perform both a thorough history and a careful physical exam to distinguish arthritis from arthralgias. The more joints involved, the more likely the child is to have systemic features of disease, including malaise, fatigue and laboratory abnormalities.

About 10% of children with polyarthritis test positive for rheumatoid factor. This subtype of juvenile arthritis most closely resembles adult rheumatoid arthritis. In long-term follow-up studies, the presence of rheumatoid factors in serum correlates with more aggressive disease and a greater possibility of joint damage and disability. So-called 'seropositive' arthritis is also marked by antibodies to cyclic citrullinated peptide (CCP), another predictor of more aggressive and destructive arthritis.

Some cases of arthritis include prominent inflammation of the entheses (insertion sites of tendons and ligaments into bone), most often the Achilles tendon at the heel or the patellar tendon at the tibial tuberosity. Furthermore, the history frequently reveals other members of the family with ankylosing spondylitis, psoriasis, inflammatory bowel disease (IBD) or Reiter's disease. These individuals, in particular those with a strong family history, may be HLA-B27 positive. Neck, back and hip involvement is common in these so-called 'spondyloarthropathies', though sacroiliitis (often manifesting as lumbosacral pain) may not be present at disease onset.<sup>24</sup> Such axial involvement typically becomes symptomatic by mid-adolescence.

### *Systemic Onset Juvenile Idiopathic Arthritis*

The third type of JIA, systemic-onset JIA or Still's disease (SoJIA), is the least common form.<sup>25</sup> Systemic complaints, particularly fever, often precede development of arthritis, so pediatricians are most likely to consider this diagnosis in children with a fever of unknown origin (FUO). SoJIA fevers are typically prolonged, minimally responsive to antipyretics, and hectic. Temperatures may reach 104° to 105° F once or twice a day, often at the same hour of the day, while dipping below normal between fevers, especially just before sunrise. Patients may experience chills and toxicity with the fevers, while such symptoms tend to improve during afebrile intervals. Appetite is frequently decreased, often accompanied by weight loss. Family history as well as a thorough review of systems and physical exam should focus on constitutional symptoms, delayed growth, poor weight gain, rashes, nail pits, oral lesions, nailbed capillary changes, clubbing, weakness and intestinal symptoms.

A diagnostic rash occurs in 90% of patients with systemic-onset JIA (Figure 12-3). The rash consists of evanescent 3- to 5-mm erythematous macular or barely papular lesions occurring most commonly on the trunk and proximal extremities. It may be asymptomatic or occasionally pruritic and is typically most prominent during fever elevations. Uncommonly, the rash can involve the face and hands and feet, but fixed lesions persisting for more than 24 hours in a location should stimulate a search for an alternative diagnosis. The rash is more likely to be atypical for the first several weeks of illness before evolving into the classic salmon pink exanthem. Similarly, early in the course of the illness a child may complain of joint pain, with frank arthritis not becoming evident for weeks or months. Less specific findings may include lymphadenopathy, hepatosplenomegaly or serositis with pericardial effusions.

### *Laboratory Assessment*

The laboratory assessment of JIA should include a complete blood cell count (CBC), sedimentation rate and ANA, as well as





**Figure 12-3** Skin eruption in systemic juvenile idiopathic arthritis.

a rheumatoid factor and anti-CCP antibodies in children with symmetric polyarthritis. The white blood cell count is frequently elevated to  $30,000/\text{mm}^3$  or more in systemic JIA, with a marked left shift. If blood counts are unexpectedly low, evidence of myelophthisis or increased cellular turnover due to leukemia may be manifested by elevated lactic acid dehydrogenase (LDH) and/or uric acid levels. Acute-phase reactants including ESR, CRP and platelets are also strikingly elevated unless a complication leads to a consumptive process such as macrophage activation syndrome (MAS) or disseminated intravascular coagulopathy (DIC). Hematocrit and levels of housekeeping proteins such as albumin are decreased commensurate with the level of inflammation.<sup>26</sup> In cases of arthritis in which other systemic illnesses are suspected (e.g. SLE, myositis or IBD), additional studies may be necessary to assess kidney, gastrointestinal and muscle function.

In boys with onset at an older age and with axial or primarily lower-extremity joint involvement, a human leukocyte antigen (HLA-B27) test may be positive in support of the diagnosis of spondyloarthritis. Close follow-up of the axial joints is particularly important in such patients, though widespread screening is not indicated as approximately 9% of all Caucasians are HLA-B27 positive, only a minority of whom have spondyloarthritis. Conversely, some populations such as native Africans almost never carry this gene, yet they may develop ankylosing spondylitis and other forms of spondyloarthritis.

Early in the course of arthritis, radiographs of involved joints show little more than soft tissue swelling and periarticular osteopenia. Bone scans in perplexing patients usually show tracer uptake on both sides of the joint, which is consistent with arthritis and not indicative of osteomyelitis. Magnetic resonance imaging (MRI) or ultrasound scanning may be helpful in visualizing intra-articular effusions and synovitis in involved joints.

### Treatment

Treatment of juvenile arthritis is directed at two discrete but related aspects of the condition, symptoms and joint damage. Nonsteroidal antiinflammatory drugs (NSAIDs) provide analgesia and some relief of inflammation. For younger children who require liquid medications, naproxen ( $\leq 10$  mg/kg twice daily), ibuprofen (10 mg/kg up to three or four times daily) or meloxicam (0.25 mg/kg divided twice daily) are available, with a preference for medications with a longer half-life that require less frequent dosing. For older children, numerous NSAIDs formulated as tablets are available, including naproxen 250 to 375 mg twice daily, diclofenac 50 to 75 mg twice daily, tolmetin (30 mg/kg/day) and meloxicam 15 mg once a day, all approved for pediatric use. The COX2 inhibitor, celecoxib, has been approved for children over the age of 2 years. Celecoxib produces less gastric irritation than routine NSAIDs, and it does not affect platelet function. In severely symptomatic or debilitating cases of polyarthritis, a brief course of systemic steroids (usually at doses  $< 1$  mg/kg/day) may serve as a bridge until disease modifying agents become effective. Conversely, an intra-articular injection with triamcinolone hexacetonide or other steroid agents may be effective for a mono- or pauciarthritis.

Second-line therapy of JIA begins with low-dose methotrexate administered on a weekly basis.<sup>27</sup> Newer agents, including TNF inhibitors (e.g. etanercept and infliximab), are available for patients in whom methotrexate therapy fails. The newest biologic agents approved for the treatment of JIA are adalimumab and abatacept. Systemic-onset JIA is best treated with early initiation of anti-IL-1 agents such as anakinra (an IL-1 receptor antagonist) or canakinumab (anti-IL-1 monoclonal antibody), or the anti-IL-6 agent tocilizumab.<sup>28</sup>

In patients with axial involvement of the neck, lumbosacral spine, hips or sacroiliac joints, as well as prominent enthesitis, diligent physical therapy is essential for maintaining range of motion. In such cases of axial involvement, vertebral fusion may occur over time. Traditional DMARDs are significantly less effective than NSAIDs and TNF inhibitors, though the extent to which these can prevent ankylosis remains unclear.<sup>29</sup>

### Prognosis

Overall, the prognosis for patients with JIA is markedly better than it was even 10 years ago. The expectation should be that any case of arthritis can be fully or largely controlled with aggressive treatment, and disability or chronic joint damage should be a rare outcome. Optimal results are more dependent upon state-of-the-art care in certain subtypes of juvenile arthritis, including systemic-onset JIA, pauciarthritis associated with chronic anterior uveitis, and rheumatoid factor-positive polyarticular JIA. Regardless, treatment with second-line agents has drastically reduced disability and the need for total joint replacement; up to 90% of children should have a favorable course and be able to maintain a normal lifestyle.

## SYSTEMIC LUPUS ERYTHEMATOSUS

SLE is the prototype of autoantibody-mediated diseases, demonstrating diverse manifestations depending upon the specific organs targeted in a particular case.<sup>30</sup> In fact, diagnosis depends upon meeting a checklist of signs and symptoms: someone with seizures, a photosensitive skin rash and oral ulcers and someone else with renal failure and thrombocytopenia might both fulfill

criteria for SLE despite having no characteristics in common. Several different mouse models mimic the human disease, and each one is caused by immunologic aberrations involving different regulatory mechanisms. Thus, SLE appears to be a final common pathway for a variety of immunoregulatory abnormalities, such as a lowered threshold for B cell activation, spontaneous T cell activation, and disruption of normal FAS-induced apoptosis.<sup>31</sup>

In humans, genetic factors are clearly important, with relatives of patients with SLE having a 30-fold increased risk of developing lupus. Nonetheless, concordance between identical twins is only about 25%, and environmental triggers (particularly viruses such as Epstein-Barr virus and certain medications), hormonal factors (with women of childbearing age having a 9-fold increased risk of developing SLE) and epigenetic changes (such as DNA methylation) all play important roles in the development of SLE. Overall, environmental and developmental factors appear to be central to the development of SLE, as only 10% of SLE cases occur before adulthood.

SLE is not a common disease. Estimates from several different series suggest that the annual incidence is approximately 0.36 cases per 100,000 children under the age of 16 years. More cases occur in African-American and Asian populations, but development under the age of 6 years is extremely rare in all ethnic groups. The female-to-male ratio among children is about 5:1, and it gradually increases after puberty.<sup>32</sup> Interestingly, this gender bias affects primarily mild cases of lupus; the likelihood of developing severe SLE is much more closely matched in boys and girls.

### Diagnosis

Diagnosis of SLE is usually based upon demonstrating at least four of 11 criteria as developed by the American College of Rheumatology (Box 12-3). In fact, technically these are classification criteria, validated in adults and intended to ensure homogeneous populations for clinical trials. Nonetheless, they provide a useful basis for evaluating the possibility of lupus, as

well as guidance for more definitive exclusion of other conditions.

Musculoskeletal symptoms are the most common manifestation of SLE. Painful but nonerosive arthritis, typically involving the small joints of the hands, develops at presentation or during the disease course in more than 90% of patients.<sup>33</sup> Three different types of rashes are characteristic of SLE and are included in the ACR classification criteria. A malar rash across the cheeks and over the bridge of the nose (thought to be reminiscent of a wolf bite and thus giving rise to the name 'lupus') is present in up to 50% of patients. The rash is more violaceous or bright pink than other erythematous facial rashes, and it is also marked by scaling and follicular plugging. The rash worsens and may blister with sun exposure, as do other photosensitive eruptions associated with SLE (Figure 12-4). Additionally, sunlight may trigger a systemic flare of SLE by damaging cutaneous tissue and releasing nuclear antigens, which are targeted by autoantibodies to form immune complexes. Thus, all children with lupus should protect their skin from ultraviolet exposure. The final rash characteristic of SLE, discoid lesions, may lead to significant scarring and altered pigmentation. It is one of the few rashes that typically affects the auricles of the ears, but it is far less common in children than in adults with lupus.

Involvement of the kidneys and the central nervous system are the most morbid manifestation of lupus, and the extent and severity of lupus nephritis and neuropsychiatric lupus largely determine the patient's prognosis. Initially, lupus nephritis may be asymptomatic or cause only mild nocturia due to tubular involvement affecting urinary concentration. Microscopic hematuria, proteinuria and cellular casts are indications of glomerular involvement. Hypertension is generally indicative of more severe renal involvement, and high blood pressure synergistically accelerates renal injury due to glomerulonephritis. Thus, it is important that this be carefully controlled, especially when corticosteroids are being used to treat systemic manifestations of SLE.

#### BOX 12-3 AMERICAN COLLEGE OF RHEUMATOLOGY 1997 CRITERIA FOR SYSTEMIC LUPUS ERYTHEMATOSUS

- Malar (butterfly) rash
- Discoid-lupus rash
- Photosensitivity
- Oral or nasal mucocutaneous ulceration
- Nonerosive arthritis
- Nephritis
  - Proteinuria 0.5 g/day
  - Cellular casts
- Encephalopathy
  - Seizures
  - Psychosis
- Pleuritis or pericarditis
- Cytopenias
- Positive immunoserology
  - Antibodies to dsDNA
  - Antibodies to Smith nuclear antigen
  - Positive tests for antiphospholipid antibodies (lupus anticoagulant or anticardiolipin antibodies)
  - Positive antinuclear antibody

From Hochberg MC. *Arthritis Rheum* 1997;40:1725.



Figure 12-4 Rash in systemic lupus erythematosus.

Chest pain may suggest lung or heart involvement in SLE. It may be caused by pleuritis, in which case shortness of breath and pain upon inspiration are the most typical symptoms. Physical examination may reveal diminished breath sounds indicating a pleural effusion, which can be documented by a chest x-ray. Pulmonary hemorrhage, a rare but potentially lethal manifestation of SLE, should be suspected in patients with cough, hypoxia and a rapid fall in hemoglobin. Hemoptysis may not be present. Costochondritis may mimic pleuritic chest pain, but on physical examination it is distinguished by the presence of discrete tender areas at the costochondral junctions along the sternum.

Pericarditis is the most common cardiac manifestation of SLE. Patients complain of precordial chest pain that is worse when leaning forward or lying in the recumbent position. A chest x-ray may show cardiomegaly, and an echocardiogram can confirm the presence of pericardial fluid. Electrocardiograms may show diminished voltages, but in general this is a less sensitive means of diagnosing pericarditis. Rarely a noninfectious endocarditis (Libman-Sacks endocarditis) may cause inflammation of the leaflets of the cardiac valves. If not treated aggressively, it can lead to acute valvular rupture and heart failure.

Neuropsychiatric involvement in SLE is rarely a presenting symptom, though headaches occur in 80% of patients during the course of the disease. Seizures, strokes, chorea and neuropathies may be caused by direct CNS involvement, but they may also be a complication of sepsis, uremia, thrombosis or hypertension. Differentiating the potential causes of neurologic and psychiatric manifestations of SLE is often very difficult, despite MR and CT imaging, neuropsychiatric testing and laboratory analysis of cerebrospinal fluid.<sup>34</sup>

Gastrointestinal involvement in SLE is uncommon, though acute pancreatitis with severe left upper quadrant pain penetrating to the back can be an emergent situation. Liver involvement may produce mild elevation of hepatocellular enzymes but rarely causes symptoms. Patients with longstanding, poorly controlled SLE, particularly those with neurologic involvement, may develop gastrointestinal hemorrhage due to intestinal vasculitis. This requires urgent and expert management: gastritis and other causes of gastrointestinal hemorrhage must be rapidly excluded in order to improve upon the reported 50% mortality rate.

Constitutional symptoms, though not specific for lupus, may significantly compromise quality of life by causing fever, weight loss and fatigue. The organic fatigue of SLE tends to occur in the afternoon and evening. Somnolence is generally responsive to treatment with steroids, but it may recur as therapy is tapered despite use of steroid-sparing agents.

### Laboratory Assessment

Laboratory abnormalities, particularly cytopenias, are typically a prominent component of SLE. Up to 20% of adults presenting with thrombocytopenia eventually develop SLE, and adolescents presenting with new-onset idiopathic thrombocytopenic purpura, or with two or more cell lines down (Evans syndrome) should be screened with at least an ANA. A CBC will frequently show anemia, leukopenia or thrombocytopenia. Anemia is Coombs' positive in 15% of patients but more commonly it is simply a manifestation of chronic disease. Leukopenia may affect overall white cell numbers, but it most often disproportionately affects lymphocyte counts. Thus, lymphopenia below

1,000/mm<sup>3</sup> is a particularly helpful marker of possible SLE because it is seen in only a handful of other conditions including viral syndromes, immunodeficiencies, sarcoidosis and hematologic malignancies.

The sedimentation rate is elevated in 90% of patients with SLE. Although this is not a specific finding, in SLE the elevated ESR is generally caused by polyclonal hypergammaglobulinemia rather than elevated acute-phase reactants. As such, it is not a useful marker of disease activity or intercurrent infection. Because the ANA test is positive in almost 100% of children with SLE, a negative ANA dramatically decreases concern for the diagnosis. In SLE the titer of ANA is usually high (>1:160), but it may be diffuse, speckled or nucleolar, and thus the reported fluorescent pattern is seldom helpful in pinpointing the diagnosis.

False-positive ANAs are seen in 2% to 5% of children at any time, and in more than 20% at some point during childhood.<sup>35</sup> These are typically of lower titer (<1:320) than are pathologic ANAs in rheumatologic disorders, and they are most commonly caused by viral syndromes. Other causes include a 'familial ANA', as is seen in 15% of first-degree relatives of a person with SLE or mixed connective tissue disease. Less than one third of such people subsequently develop a systemic rheumatologic disorder. Repeat testing of children with low-titer positive ANAs is generally not necessary unless the clinical course suggests that an autoimmune process may be evolving.

In patients with a high-titer positive ANA, an ANA profile may provide increased disease specificity. Table 12-1 lists the elements of the ANA profile and their disease associations. Only 60% of patients fulfilling the diagnostic criteria for SLE will have specific identifiable autoantibodies on the ANA profile. Anti-dsDNA antibodies are a marker for worsening renal and cutaneous involvement, while other antibodies do not necessarily correlate with disease course.

In patients with lupus nephritis, routine urinalysis is the most sensitive indicator of both disease activity and response to therapy. Hematuria is usually microscopic. Cellular casts are helpful but depend on the freshness of the specimen. Proteinuria can be quantitated and followed with a spot protein-to-creatinine ratio. Values less than 0.2 are normal, and values greater than 2.0 are indicative of nephrotic levels of proteinuria. Timed collections of urine to quantify proteinuria are both tedious and frequently inaccurate. Similarly, serum creatinine levels provide accurate information, but the glomerular filtration rate must be below 50% of normal before it is reflected in an elevated serum creatinine. In case of doubt, timed creatinine clearances can provide additional information.

TABLE 12-1 Antinuclear Antibody Profile

Test	Disease Association
Anti-DNA	Systemic lupus erythematosus (SLE) with nephritis
Anti-SM (Smith)	SLE
Anti-SSA/anti-SSB	SLE with photosensitivity Sjögren's syndrome Neonatal SLE
Antiribonuclear protein	SLE and mixed connective tissue disease
Anticentromere or anti-SCL70	Scleroderma



The serum C3 level is useful both for supporting the diagnosis of SLE and monitoring disease activity, though hypocomplementemia is not a criterion for classification. Antiphospholipid antibodies, on the other hand, are included among the criteria for SLE, as are false-positive serologic tests for syphilis, which measure the same phenomenon. These antibodies are clinically significant as well, as they contribute to an increased risk of venous and arterial thromboses. *In vitro*, however, they lead to a prolonged partial tissue prothrombin time that does not correct when samples are mixed with fresh plasma.

### Treatment

Essentially all patients with SLE should be treated with an anti-malarial agent, which is beneficial for cutaneous manifestations, joint symptoms and fatigue. More importantly, however, hydroxychloroquine and quinacrine decrease autoantigen presentation and serve to greatly increase the duration and resilience of disease remissions.<sup>36</sup> A prolonged trial, up to 6 months or more, may be required before the benefits of hydroxychloroquine are recognized. Hydroxychloroquine should be used at a dose of <7 mg/kg/day; above this level there is an increased risk of potentially irreversible retinal toxicity. Additional potential side-effects include nausea, abdominal pain, reversible palsy of ocular muscles and persistent skin graying (especially in sun-exposed areas). Quinacrine is used less commonly, primarily because it often causes yellowing of the skin. It is a useful alternative in patients who develop ocular toxicity from hydroxychloroquine, though it is not available in North America.

More severe manifestations of SLE, particularly nephritis and cerebritis, are generally treated with corticosteroids and immunosuppression.<sup>37</sup> For seriously ill children, more rapid control of symptoms can be achieved with intravenous methylprednisolone (30 mg/kg with a maximum dose of 1,000 mg) given once a day for 3 days. This is transitioned to high-dose prednisone, 2 mg/kg/day, divided once or twice daily.

While other agents do not provide the short-term efficacy and safety of steroids, reduction or discontinuation of steroids is essential to avoid serious side-effects during long-term treatment. A variety of agents, including azathioprine (AZA, Imuran®), mycophenolate mofetil (MMF, CellCept®) and cyclophosphamide (CTX, Cytosan®), are effective steroid-sparing agents. Choice among these depends upon the extent of extrarenal involvement (for which MMF appears to be less effective) and severity (both the intensity of immunosuppression and the potential toxicity of CTX are generally greater than with the other agents). As in malignant conditions, a more potent medication may be used for 3 to 6 months to induce remission, and then be replaced by a safer agent for maintenance therapy. Azathioprine is most often the initial immunosuppressant at a dose of 2 to 3 mg/kg/day. Side-effects include bone marrow suppression, opportunistic infections, nausea and liver function abnormalities. MMF inhibits the enzyme inosine monophosphate dehydrogenase, leading to reduced synthesis of guanosine nucleosides. The dose is 600 to 800 mg/m<sup>2</sup> with a maximum of 1 to 1.5 g twice a day. Side-effects include bone marrow suppression, opportunistic infections and diarrhea. Methotrexate administered once a week may be beneficial for the arthritic manifestations of SLE, but it is seldom effective for treating major organ involvement such as kidney disease. Patients who fail management with azathioprine or MMF are candidates for treatment with cyclophosphamide, generally given as a monthly or biweekly intravenous pulse.

With control of symptoms and improvement in laboratory results (i.e. normal lymphocyte count, improved C3 levels and clearing of urinary sediment), the dose of prednisone is reduced and condensed to a single daily dose. The legion of steroid side-effects mandates a dose reduction to the lowest level that will keep the patient well. This is particularly important in children, who are prone to growth suppression and osteopenia with even very low steroid doses. In any case, ongoing treatment with an agent capable of maintaining remission is essential if toxic doses of steroids are to be avoided.

Many biologic agents are currently under study to modify aspects of the immune response in patients with SLE. Rituximab, a monoclonal antibody that depletes B lymphocytes, did not meet its endpoints in a pivotal trial for use in lupus nephritis despite initial optimism in patients with autoantibody-mediated diseases.<sup>38</sup> A newer nondepleting anti-B cell molecule, belimumab, did receive approval in 2013 as the first agent approved by the US Food and Drug Administration for treatment of SLE in 56 years.<sup>39</sup> It is an antibody targeting B cell activating factor (BAFF), also known as B lymphocyte stimulator (BLyS), a cytokine central to B cell survival, immunoglobulin class switching, and germinal center formation). A variety of novel treatments for SLE are in the pipeline.<sup>40</sup>

### Prognosis

SLE often fluctuates in severity. The first year after diagnosis is typically the most difficult as evolving organ system involvement necessitates close monitoring and frequent medication adjustments. By the end of the second year, most patients will have defined individual disease manifestations and organ system involvement. For instance, new onset of renal disease or central nervous system disease is unusual after the first 2 years.

The prognosis for survival with SLE has improved markedly since the 1980s. Most series have shown a 10-year survival of 85% to 90%. Over this same interval, the causes of death in SLE patients have changed. End-stage renal disease was previously the major cause of death, but renal deaths are now rare with modern management including dialysis and kidney transplant. Serious systemic infections now account for most of the mortality in lupus. These infections result both from immune dysregulation resulting from the underlying disease and from immunosuppressive effects of medications necessary for disease control. In order to ameliorate these risks, immunization against pneumococcus and meningococcus is indicated in all patients. Additionally, pneumocystis prophylaxis should be considered in patients on high-dose steroid and immunosuppressant therapy. A second peak in mortality, typically beginning in the fourth decade of life, is caused by accelerated arteriosclerosis resulting from dyslipoproteinemia over decades of illness.

### JUVENILE DERMATOMYOSITIS

Juvenile dermatomyositis (JDMS) is a rare idiopathic disease of childhood characterized by a pathognomonic rash and proximal muscle weakness.<sup>41</sup> It is distinguished from adult dermatomyositis by the absence of an association with malignancies, a unique vascular pathology and a more consistent response to therapy. The disease has a worldwide incidence of approximately 0.4 cases per 100,000 children under the age of 16 years; girls are more often affected than boys. The rash frequently begins before the child becomes noticeably weak.



## Diagnosis

Muscle disease in JDMS most often presents as the subacute onset of proximal muscle weakness. Neck, pelvis and core muscles are most affected. Children may first note decreased stamina when playing sports or walking in a mall. This progresses to increasing difficulty climbing stairs or rising from a chair. Shoulder girdle manifestations may include difficulty combing one's hair or reaching for items over the head. Untreated, the weakness tends to progress until children have difficulty getting off the floor or stabilizing their head while riding in a car. The weakness is usually out of proportion to soreness or tenderness of affected muscles. The distal muscles of the hands and feet are spared until very late in the course of the disease. Deep tendon reflexes and other aspects of the neurologic examination are typically normal until weakness is so severe that reflexes are difficult to elicit.

The rash in JDMS reflects the microangiopathy that mediates the disease. It is photosensitive, slightly pink or violaceous, and most commonly affects the extensor surfaces of the hands, elbows and knees. Many patients also develop a purplish discoloration of the upper eyelids known as a 'heliotrope' rash (named after the purple flower). Another characteristic cutaneous manifestation is a scaling, erythematous eruption of the knuckles known as Gottron's papules (Figure 12-5). The vascular nature of the condition is reflected in abnormalities of the nail bed capillaries, reflective of small vessel angiopathy seen only in SLE, scleroderma, dermatomyositis and mixed connective tissue disease.

In severe or poorly controlled cases of JDMS, patients may develop involvement of the muscles and vessels of the digestive tract. This is manifested as dysphagia (difficulty swallowing), dysphonia (a nasal quality to the voice) and dysmotility, leading to malabsorption, abdominal pain and diarrhea. Patients are at risk for aspiration and visceral perforation, and they require aggressive treatment to avoid severe sequelae. Children with persistent active muscle inflammation due to JDMS are also at risk of developing calcinosis. It may be limited to small, localized deposits or lead to extensive, debilitating subcutaneous calcifications involving much of the body. This is prevented by early, aggressive therapy to control the myositis;<sup>42</sup> calcinosis is very difficult to treat once established.

The cause of JDMS is unknown. Familial cases are rare, but some genes are over-represented among patients with inflammatory myopathies, especially certain HLA haplotypes.<sup>43</sup> The



**Figure 12-5** Rash in juvenile dermatomyositis.

diagnosis is established using modified Bohan and Peter's criteria including demonstration of proximal muscle weakness, myositis and a characteristic rash.<sup>44</sup> Originally, these requirements were fulfilled by documenting elevated muscle enzymes, an abnormal electromyogram and, at times, a distinctive muscle biopsy. In children with characteristic cutaneous findings, evidence of muscle inflammation on MRI as well as elevation of muscle enzymes (CK, AST, ALT, LDH and/or aldolase) is now generally sufficient for a presumptive diagnosis of JDMS. In addition, the microangiopathic findings may be reflected in elevated levels of the von Willebrand factor antigen. Autoantibodies are often present, including a positive ANA in at least 10% of cases, myositis-specific antibodies in up to 63% of children, and myositis-associated antibodies in 10% of cases.<sup>45</sup> These markers may allow classification of children with inflammatory myopathies into groups more likely to respond to specific therapeutic agents.

## Differential Diagnosis

The differential diagnosis of JDMS includes other rheumatic diseases such as SLE and mixed connective tissue disease as well as polyarteritis nodosa, which may preferentially affect muscles early in the disease course. Muscle enzymes may be as high during the acute phase of viral myositis as in JDMS, but generally such infections cause more muscle pain. Neuropathic causes of weakness generally have more prominent distal involvement, while muscular dystrophies do not manifest the rash or angiopathy of JDMS.

## Therapy

Early case series of JDMS were marked by mortality rates as high as 35%, generally due to gastrointestinal catastrophes, aspiration, respiratory failure or arrhythmias (due to involvement of the cardiac conducting system). With the introduction of pulsed-dose steroids for rapid control of muscle inflammation, followed by early substitution of steroid-sparing agents to minimize steroid side-effects, cures are now reported in up to 90% of children. Case reports document efficacy of a wide variety of immunosuppressive therapy in at least some cases, though most centers preferentially use methotrexate, calcineurin inhibitors (cyclosporine, tacrolimus) and/or IVIG. It is essential to control myositis fully to prevent development of calcinosis, so muscle enzymes and, if necessary, MRI changes in the proximal leg muscles are followed closely to detect residual muscle inflammation.

Skin involvement often is not synchronous with myositis, and agents effective in controlling muscle involvement are not necessarily beneficial for the rash of JDMS. Hydroxychloroquine and topical tacrolimus are helpful, and in resistant cases IVIG or rituximab may be useful. Sunscreens are useful for minimizing photodamage, which can lead to chronic skin changes including thinning and dyspigmentation. Physical therapy is necessary to avoid or reverse contractures, but strengthening exercises should be avoided as long as muscle inflammation persists as they may exacerbate the myositis. Once all signs of active inflammation are controlled, resistive exercises are preferred to aid in muscle strength recovery.

## Conclusions

This is a particularly exciting time to take care of children with inflammatory conditions. The rheumatologic illnesses

account for a major proportion of chronic diseases of childhood, but for the first time, it is often possible to suppress symptoms safely and allow children to enjoy normal growth and development into adulthood. Further, the expectation is that within the not-too-distant future, everything from juvenile arthritis to systemic lupus erythematosus will be curable. As the genetic, environmental and epigenetic factors affecting

inflammatory disorders are further elucidated, we may soon look back on rheumatology clinics much as we view sanatoriums and leper colonies.

The complete reference list can be found on the companion Expert Consult website at <http://www.expertconsult.inkling.com>.



## KEY REFERENCES

1. Medzhitov R. Origin and physiological roles of inflammation. *Nature* 2008;454:428–35.
3. Mehta J. Laboratory testing in pediatric rheumatology. *Pediatr Clin North Am* 2012;59:263–84.
7. Dinarello CA. Anti-inflammatory agents: present and future. *Cell* 2010;140:935–50.
11. Newburger JW, Takahashi M, Gerber MA, Gewitz MH, Tani LY, Burns JC, et al. Diagnosis, treatment, and long-term management of Kawasaki disease: a statement for health professionals from the Committee on Rheumatic Fever, Endocarditis and Kawasaki Disease, Council on Cardiovascular Disease in the Young, American Heart Association. *Circulation* 2004;110:2747–71.
12. Ramanan AV, Sen ES. New age of biological therapies in paediatric rheumatology. *Arch Dis Child* 2014;99:679–85.
13. Chan AC, Carter PJ. Therapeutic antibodies for autoimmunity and inflammation. *Nat Rev Immunol* 2010;10:301–16.
28. Martini A. Systemic juvenile idiopathic arthritis. *Autoimmun Rev* 2012;12:56–9.
40. Tsokos GC. Systemic lupus erythematosus. *N Engl J Med* 2011;365:2110–21.
42. Kim S, El-Hallak M, Dedeoglu F, Zurakowski D, Fuhlbrigge RC, Sundel RP. Complete and sustained remission of juvenile dermatomyositis resulting from aggressive treatment. *Arthritis Rheum* 2009;60:1825–30.
45. Rider LG, Shah M, Mamyrova G, Huber AM, Rice MM, Targoff IN, et al. The myositis autoantibody phenotypes of the juvenile idiopathic inflammatory myopathies. *Medicine (Baltimore)* 2013;92:223–43.

## REFERENCES

- Medzhitov R. Origin and physiological roles of inflammation. *Nature* 2008;454:428–35.
- Serhan CS, Savill J. Resolution of inflammation: the beginning programs the end. *Nat Immunol* 2005;6:1191–7.
- Mehta J. Laboratory testing in pediatric rheumatology. *Pediatr Clin North Am* 2012;59:263–84.
- Volanakis JE. Human C-reactive protein: expression, structure, and function. *Mol Immunol* 2001;38:189–97.
- van der Heijde DMFM. Joint erosions and patients with early rheumatoid arthritis. *Rheumatology* 1995;XXXIV(Suppl. 2):74–8.
- Nigrovic PA. Review: is there a window of opportunity for treatment of systemic juvenile idiopathic arthritis? *Arthritis Rheumatol* 2014;66:1405–13.
- Dinarelo CA. Anti-inflammatory agents: present and future. *Cell* 2010;140:935–50.
- Kessler EA, Becker ML. Therapeutic advancements in juvenile idiopathic arthritis. *Best Pract Res Clin Rheumatol* 2014;28:293–313.
- Braun-Moscovici Y, Furst DE. Plasmapheresis for rheumatic diseases in the twenty-first century: take it or leave it? *Curr Opin Rheumatol* 2003;15:197–204.
- Fasano MB, Sullivan KE, Sarpong SB, Wood RA, Jones SM, Johns CJ, et al. Sarcoidosis and common variable immunodeficiency. Report of 8 cases and review of the literature. *Medicine (Baltimore)* 1996;75:251–61.
- Newburger JW, Takahashi M, Gerber MA, Gewitz MH, Tani LY, Burns JC, et al. Diagnosis, treatment, and long-term management of Kawasaki disease: a statement for health professionals from the Committee on Rheumatic Fever, Endocarditis and Kawasaki Disease, Council on Cardiovascular Disease in the Young, American Heart Association. Committee on Rheumatic Fever, Endocarditis and Kawasaki Disease; Council on Cardiovascular Disease in the Young; American Heart Association; American Academy of Pediatrics. *Circulation* 2004;110:2747–71.
- Ramanan AV, Sen ES. New age of biological therapies in paediatric rheumatology. *Arch Dis Child* 2014;99:679–85.
- Chan AC, Carter PJ. Therapeutic antibodies for autoimmunity and inflammation. *Nat Rev Immunol* 2010;10:301–16.
- Scolnik PA. mAbs: a business perspective. *MAbs* 2009;1:179–84.
- Feist E, Burmester GR. Small molecules targeting JAKs – a new approach in the treatment of rheumatoid arthritis. *Rheumatology (Oxford)* 2013;52:1352–7.
- Gordon J, Spiera R. Imatinib and the treatment of fibrosis: recent trials and tribulations. *Curr Rheumatol Rep* 2011;13:51–8.
- Ichikawa HT, Conley T, Muchamuel T, Jiang J, Lee S, Owen T, et al. Beneficial effect of novel proteasome inhibitors in murine lupus via dual inhibition of type I interferon and autoantibody-secreting cells. *Arthritis Rheum* 2012;64:493–503.
- Costedoat-Chalumeau N, Dunogué B, Morel N. Hydroxychloroquine: a multifaceted treatment in lupus. *Presse Med* 2014;43(6 Pt 2):e167–80.
- Coleman MA, Steptoe RJ. Induction of antigen-specific tolerance through hematopoietic stem cell-mediated gene therapy: the future for therapy of autoimmune disease? *Autoimmun Rev* 2012;12:195–203.
- Illei GG, Cervera R, Burt RK, Doria A, Hiepe F, Jayne D, et al. Current state and future directions of autologous hematopoietic stem cell transplantation in systemic lupus erythematosus. *Ann Rheum Dis* 2011;70:2071–4.
- Kahn PJ. Juvenile idiopathic arthritis – what the clinician needs to know. *Bull Hosp Jt Dis* 2013;71:194–9.
- Eisenstein EM, Berkun Y. Diagnosis and classification of juvenile idiopathic arthritis. *J Autoimmun* 2014;48–49:31–3.
- Tugal-Tutkun I, Quartier P, Bodaghi B. Disease of the year: juvenile idiopathic arthritis-associated uveitis – classification and diagnostic approach. *Ocul Immunol Inflamm* 2014;22:56–63.
- Ramanathan A, Srinivasalu H, Colbert RA. Update on juvenile spondyloarthritis. *Rheum Dis Clin North Am* 2013;39:767–88.
- Correll CK, Binstadt BA. Advances in the pathogenesis and treatment of systemic juvenile idiopathic arthritis. *Pediatr Res* 2014;75:176–83.
- Reyhhan I, Goldberg BR, Gottlieb BS. Common presentations of pediatric rheumatologic diseases: a generalist's guide. *Curr Opin Pediatr* 2013;25:388–96.
- Hashkes PJ, Becker ML, Cabral DA, Laxer RM, Paller AS, Rabinovich CE, et al. Methotrexate: new uses for an old drug. *J Pediatr* 2014;164:231–6.
- Martini A. Systemic juvenile idiopathic arthritis. *Autoimmun Rev* 2012;12:56–9.
- van der Heijde D, Sieper J, Maksymowych WP, Dougados M, Burgos-Vargas R, Landewé R, et al. 2010 Update of the international ASAS recommendations for the use of anti-TNF agents in patients with axial spondyloarthritis. *Ann Rheum Dis* 2011;70:905–8.
- Malattia C, Martini A. Paediatric-onset systemic lupus erythematosus. *Best Pract Res Clin Rheumatol* 2013;27:351–62.
- Crompton SP, Morawski PA, Bolland S. Linking susceptibility genes and pathogenesis mechanisms using mouse models of systemic lupus erythematosus. *DMM Dis Models Mech* 2014;7:1033–46.
- Midgley A, Watson L, Beresford MW. New insights into the pathogenesis and management of lupus in children. *Arch Dis Child* 2014;99(6):563–7.
- Iqbal S, Sher MR, Good RA, Cawkwell GD. Diversity in presenting manifestations of systemic lupus erythematosus in children. *J Pediatr* 1999;135:500–5.
- Zardi EM, Taccone A, Marigliano B, Margiotta DP, Afeltra A. Neuropsychiatric systemic lupus erythematosus: tools for the diagnosis. *Autoimmun Rev* 2014;13:831–9.
- Weiss JE. Pediatric systemic lupus erythematosus: more than a positive antinuclear antibody. *Pediatr Rev* 2012;33:62–73.
- Lee SJ, Silverman E, Bargman JM. The role of antimalarial agents in the treatment of SLE and lupus nephritis. *Nat Rev Nephrol* 2011;7:718–29.
- Mina R, von Scheven E, Ardoin SP, Eberhard BA, Punaro M, Ilowite N, et al. Consensus treatment plans for induction therapy of newly diagnosed proliferative lupus nephritis in juvenile systemic lupus erythematosus. *Arthritis Care Res (Hoboken)* 2012;64:375–83.
- Merrill JT, Neuwelt CM, Wallace DJ, Shanahan JC, Latinis KM, Oates JC, et al. Efficacy and safety of rituximab in moderately-to-severely active systemic lupus erythematosus: the randomized, double-blind, phase II/III systemic lupus erythematosus evaluation of rituximab trial. *Arthritis Rheum* 2010;62:222–33.
- Furie R, Petri M, Zamani O, Cervera R, Wallace DJ, Tegzová D, et al. A phase III, randomized, placebo-controlled study of belimumab, a monoclonal antibody that inhibits B lymphocyte stimulator, in patients with systemic lupus erythematosus. *Arthritis Rheum* 2011;63:3918–30.
- Tsokos GC. Systemic lupus erythematosus. *N Engl J Med* 2011;365:2110–21.
- Feldman BM, Rider LG, Reed AM, Pachman LM. Juvenile dermatomyositis and other idiopathic inflammatory myopathies. *Lancet* 2008;371:2201–12.
- Kim S, El-Hallak M, Dedeoglu F, Zurawski D, Fuhlbrigge RC, Sundel RP. Complete and sustained remission of juvenile dermatomyositis resulting from aggressive treatment. *Arthritis Rheum* 2009;60:1825–30.
- Chinoy H, Lamb JA, Ollier WER. Recent advances in the immunogenetics of idiopathic inflammatory myopathy. *Arthritis Res Ther* 2011;13:216–24.
- Bohan A, Peter JB. Polymyositis and dermatomyositis. *N Engl J Med* 1975;292:344–7, 403–7.
- Rider LG, Shah M, Mamyrova G, Huber AM, Rice MM, Targoff IN, et al. The myositis autoantibody phenotypes of the juvenile idiopathic inflammatory myopathies. *Medicine (Baltimore)* 2013;92:223–43.

# Congenital Immune Dysregulation Disorders

THOMAS A. FLEISHER | JOAO BOSCO OLIVEIRA | TROY R. TORGERSON

## KEY POINTS

- Monogenic defects have been identified that interfere with self tolerance.
- Human defects of self tolerance can affect both central and peripheral tolerance.
- Linking specific genetic defects to resulting autoimmune patterns reveals specific self tolerance pathways.
- Additional genetic/environmental factors appear to impact monogenic autoimmune processes.
- It is likely that additional genetic defects resulting in autoimmunity will be identified.

Down-regulation of the immune response has become a subject of increased focus with this area of investigation complementing extensive work done to characterize the differentiation and activation of immune cells. Recently described prototypic human disorders that affect various immunoregulatory pathways have provided important insights into mechanisms required for tolerance and the control of immune responses. In this chapter we will discuss congenital disorders that impact central deletion of autoreactive T cells in the thymus as well as those that impact other mechanisms involved in the maintenance of tolerance in the periphery. In all of these disorders the clinical phenotype includes autoimmunity together with other manifestations.

## Autoimmune Polyendocrinopathy, Candidiasis, Ectodermal Dystrophy (APECED)

APECED (OMIM #240300) is the prototypic disorder of defective central immune tolerance. It is an autosomal recessive disorder characterized by systemic autoimmunity that primarily affects endocrine organs, particularly the parathyroid and adrenal glands.<sup>1,2</sup> Hypoparathyroidism, adrenal insufficiency and chronic mucocutaneous candidiasis typically characterize the syndrome but patients may also have type 1 diabetes, gonadal failure, pernicious anemia, autoimmune hepatitis and cutaneous manifestations (Box 13-1).<sup>1,2</sup>

## GENETICS AND IMMUNOPATHOGENESIS

APECED is caused by mutations in the gene encoding the autoimmune regulator (AIRE), a transcription factor that plays a role in ectopic expression of tissue-specific antigens by thymic

medullary epithelial cells (mTEC). In mice, AIRE-mediated self-antigen expression in the thymus has been shown to play a significant role in negative selection of autoreactive T cell clones.<sup>3,4</sup> The mechanism by which AIRE causes expression of tissue-specific gene products may be by regulating large-scale access to chromatin.

Because naturally arising T regulatory (T<sub>REG</sub>) cells are also thymically derived, AIRE may also play a role in generation of T<sub>REG</sub> cells. This is supported by a transgenic mouse model with a monospecific T cell receptor: autoimmunity seen in *Aire*<sup>-/-</sup> mice results from a combination of defective negative selection and defective generation of antigen-specific T<sub>REG</sub> cells.<sup>5</sup> The role of AIRE in generation and function of T<sub>REG</sub> cells has also been investigated in APECED where a decreased percentage of CD4<sup>+</sup>CD25<sup>high</sup> T cells was found. In addition, CD4<sup>+</sup>CD25<sup>high</sup> T cells expressed less FOXP3 than control cells.<sup>6</sup> Furthermore, isolated T<sub>REG</sub> cells from APECED patients had a decreased ability to suppress proliferation of effector T cells in vitro.<sup>6</sup> These data suggest that AIRE plays a significant role in the generation of functional T<sub>REG</sub> cells in humans.

In addition to the recognized effector and regulatory T cell abnormalities observed in APECED, patients have a propensity to develop a broad range of pathogenic, tissue-specific autoantibodies including those directed at the parathyroids, adrenals, ovaries, lungs, gut and others.<sup>7-9</sup> In addition, neutralizing autoantibodies against type I interferons ( $\alpha$  and  $\omega$ ), interleukin-17 (IL-17), and interleukin-22 (IL-22) have been identified in many APECED patients and are associated with chronic mucocutaneous candidiasis.<sup>10-12</sup>

## DIAGNOSIS AND TREATMENT

APECED is typically suspected in patients who have two of the three basic symptoms: hypoparathyroidism (usually manifested by hypocalcemia), adrenal insufficiency and mucocutaneous candidiasis. Suspicion is raised further by the presence of other autoimmune manifestations and a definitive diagnosis can be made by sequencing of the *AIRE* gene.

Despite the impressive autoimmune phenotype, most of the therapy for APECED has focused on symptomatic treatment including calcium supplementation, steroid replacement and the management of diabetes and other endocrinopathies. Particularly problematic is the mucocutaneous candidiasis, which causes significant morbidity and increases the risk of oral malignancies. In many patients, the candidal species develop reduced sensitivity to azole antifungals over time.<sup>13</sup>

Immunosuppressants are not routinely used in APECED unless patients develop autoimmune hepatitis or renal disease, in which azathioprine and cyclosporin A (cyclosporine) have shown benefit.<sup>2</sup> Recent studies in *Aire*<sup>-/-</sup> mice have



**BOX 13-1 KEY CONCEPTS****IMMUNOPATHOGENESIS OF APECED SYNDROME**

- Endocrinopathy: hypocalcemia and adrenal insufficiency caused by autoimmunity to parathyroids and adrenals
- Chronic mucocutaneous candidiasis (CMC): caused by neutralizing autoantibodies to IL-17, IL-22 and other cytokines
- Autoimmunity: thymic selection defect prevents appropriate elimination of autoreactive T cells and generation of regulatory T cells

**BOX 13-2 KEY CONCEPTS****IMMUNOPATHOGENESIS OF IPEX SYNDROME**

- Enteropathy: severe watery diarrhea caused by autoimmune enteropathy
- Endocrinopathy: type I diabetes and thyroiditis caused by autoimmunity to pancreas and thyroid
- Autoimmunity: absence of functional regulatory T cells

demonstrated a significant role for B cells and autoantibodies in pathogenesis, and one recent case report demonstrated efficacy of B cell depletion therapy in an APECED patient with autoimmune lung disease.<sup>14,15</sup>

## Immune Dysregulation, Polyendocrinopathy, Enteropathy, X-Linked (IPEX)

IPEX syndrome (OMIM #304930) is the prototype of defective peripheral immune tolerance. The basic clinical triad of IPEX includes autoimmune enteropathy, early onset endocrinopathy and dermatitis (Box 13-2).<sup>16–18</sup> The enteropathy typically presents early in life as watery diarrhea, frequently resulting in malnutrition and failure to thrive. Type 1 diabetes is the most common endocrinopathy but clinical and/or laboratory evidence of thyroiditis is also common. Eczema is the most common dermatitis in IPEX but erythroderma, psoriasiform dermatitis and pemphigus nodularis have also been observed.<sup>19–21</sup>

In addition to the 'IPEX triad', most patients with IPEX also have other associated autoimmune disorders including autoimmune cytopenias, nephropathy or hepatic disease (Torgerson & Ochs, unpublished data). These conditions contribute substantially to the morbidity of patients with IPEX and increase the risk of death from disease. Patients with the classical form of the disease typically die secondary to malnutrition, electrolyte imbalance or infection before the age of 2 if not treated with aggressive immunosuppression.<sup>21</sup>

### GENETICS AND IMMUNOPATHOGENESIS

IPEX is caused by mutations in the forkhead DNA-binding protein FOXP3, which is expressed by CD4<sup>+</sup>CD25<sup>high</sup> regulatory T cells and is required for T<sub>REG</sub> cells to develop suppressor function.<sup>22–26</sup> This has been shown most elegantly in two separate knock-in mouse models with CD4<sup>+</sup>T cells unable to express functional Foxp3. Despite this, the cells still acquired the expected cell surface phenotype of a T<sub>REG</sub> (CD25<sup>high</sup>CTLA-4<sup>high</sup>GITR<sup>high</sup>) but had no suppressive function and developed a gene expression profile suggestive of an effector/cytotoxic T cell resulting in systemic autoimmunity similar to *Foxp3*<sup>-/-</sup>mice.<sup>26</sup>

Under quiescent conditions, FOXP3 expression is restricted primarily to T<sub>REG</sub> cells, however it can also be inducibly expressed in a large percentage of human T cells upon activation.<sup>27–30</sup> Originally shown to be a transcriptional repressor acting on key cytokine genes,<sup>31–33</sup> recent genome-wide screening approaches suggest that FOXP3 functions more commonly as a transcriptional enhancer.<sup>34,35</sup>

Most pathologic mutations in FOXP3 cluster in three important functional domains of the protein: the C-terminal forkhead DNA-binding domain, the leucine zipper and the N-terminal repression domain.<sup>36</sup> Recent studies suggest that FOXP3 physically and functionally interacts with other transcription factors including NFAT, NF-κB, AML-1/RUNX1 and the retinoic acid receptor related orphan receptors RORα and RORγt to modulate gene transcription at key cytokine promoters.<sup>31,32,37</sup>

### DIAGNOSIS AND TREATMENT

IPEX is generally suspected in any patient who demonstrates at least two of the three basic clinical features of IPEX including enteropathy, endocrinopathy (type 1 diabetes mellitus or thyroiditis) and dermatitis. Flow cytometry using intracellular staining for FOXP3 protein to identify FOXP3<sup>+</sup>T<sub>REG</sub> cells is a valuable tool to rapidly screen for the absence of T<sub>REG</sub>. Approximately 5–7% of the CD4<sup>+</sup>T cell population is positive for FOXP3 expression in healthy controls and a marked decrease suggests a diagnosis of IPEX that may be confirmed by sequencing of the *FOXP3* gene (Figure 13-1). Definitive diagnosis involves identification of a mutation in *FOXP3* (Torgerson, unpublished data).

From a clinical laboratory standpoint, the most consistent abnormality among IPEX patients is markedly elevated IgE while IgA is also modestly elevated in more than 50% of patients (Torgerson, unpublished data). There are no consistent abnormalities in absolute lymphocyte numbers and T cells usually proliferate normally in vitro.

Adoptive transfer studies in mice have demonstrated that the CD4<sup>+</sup>T cells from an affected *Foxp3*<sup>-/-</sup> male are capable of recapitulating the disease phenotype in a lymphopenic recipient.<sup>38</sup> Treatment of IPEX has therefore focused primarily on suppression of unregulated, auto-aggressive T cells using cyclosporin A, tacrolimus (FK506) or sirolimus (rapamycin).<sup>15,16,39,40</sup> These are often combined with steroids and/or other immunomodulatory agents including methotrexate or azathioprine.<sup>40,41</sup> In cases where there is evidence for pathogenic autoantibodies, rituximab (anti-CD20) has proven effective.<sup>19</sup> Immunosuppression is often effective initially and there is one report of a patient with IPEX being maintained for a prolonged period; however, most patients ultimately fail therapy.<sup>42</sup> Currently, bone marrow transplantation holds the only hope for a long-term cure<sup>43–45</sup> and reduced intensity regimens seem to be associated with better survival.<sup>44,45</sup> Rapid diagnosis and transplantation early in the course of disease, before the pancreatic islet cells are destroyed, should be the goal.

### STAT1 Gain of Function (STAT1-GOF) Mutations

The signal transducer and activator of transcription (STAT) family of DNA-binding proteins are critical mediators of cytokine and growth factor signaling in cells. STAT1 is the primary

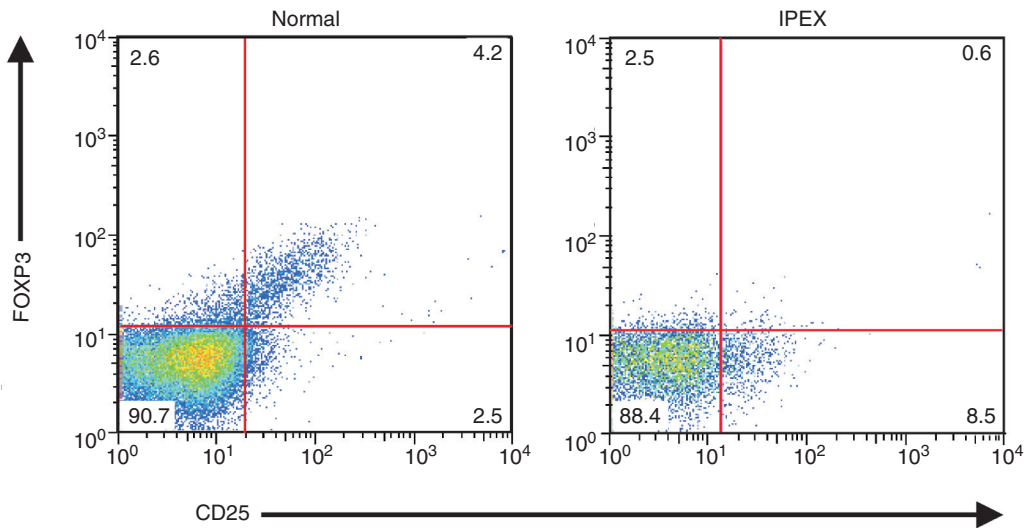

**Figure 13-1** Absence of FOXP3<sup>+</sup> regulatory T cells in IPEX. Peripheral blood mononuclear cells (PBMCs) from a normal individual and a patient with IPEX were fixed, permeabilized and stained for the presence of CD4, CD25 and FOXP3. After gating on the CD4<sup>+</sup> T cell population, two-dimensional analysis demonstrates the absence of CD25<sup>+</sup> FOXP3<sup>+</sup> regulatory T cells in the PBMCs of a patient with IPEX syndrome due to a mutation in the polyadenylation site of the *FOXP3* gene.

transcription factor activated by interferons so it plays a major role in normal immune responses, particularly to viral, mycobacterial and fungal pathogens. Recently described autosomal dominant mutations that lead to a gain of STAT1 function (STAT1-GOF; OMIM #614162) typically present with CMC but may also have disseminated infections with dimorphic yeast or mycobacteria and variable forms of autoimmunity.<sup>46,47</sup> Recently, STAT1-GOF mutations were identified in a cohort of patients with IPEX-like autoimmunity (severe early-onset enteropathy, dermatitis, thyroiditis and type 1 diabetes).<sup>48</sup> All but one of the identified patients also had a history of CMC, although in some cases the CMC was mild or only occurred after treatment with antibiotics.

In addition to IPEX-like autoimmunity and CMC, patients had recurrent respiratory infections and bronchiectasis, herpesviral infections (HSV and VZV), short stature with growth-hormone insufficiency, and arterial aneurysms (cardiac and CNS) (Box 13-3).<sup>48</sup> Unlike IPEX, patients with STAT1-GOF mutations had more evidence of humoral immune dysfunction including poor vaccine responses, with more than half of the patients requiring treatment with immunoglobulin replacement therapy, and normal (or mildly elevated) serum IgE levels.

### GENETICS AND IMMUNOPATHOGENESIS

Inheritance is autosomal dominant, caused by heterozygous missense mutations in the *STAT1* gene. All of the identified mutations that cause a gain of STAT1 function lie within the coiled-coil or DNA-binding domains of the STAT1 protein and many are associated with increased phosphorylation and delayed dephosphorylation of STAT1.<sup>47</sup> In most patients, the percentage of IL-17 secreting Th17 cells in the CD4<sup>+</sup> T cell population is markedly reduced but not absent, likely contributing to the susceptibility to CMC. The mechanism of susceptibility to autoimmunity in this disorder is, however, less clear. Regulatory T cells are present in normal to near-normal

### BOX 13-3 KEY CONCEPTS

#### IMMUNOPATHOGENESIS OF STAT1 GAIN-OF-FUNCTION SYNDROME

- Chronic mucocutaneous candidiasis (CMC): abnormal generation of functional Th17 cells
- Immunodeficiency: some patients make insufficient antibody responses to vaccination
- Autoimmunity: IPEX-like enteropathy and endocrinopathies, may be related to hyperactivation of STAT1 in response to interferons

numbers and appear to have normal function based on a limited number of evaluated patients.<sup>48</sup>

### DIAGNOSIS AND TREATMENT

Hyperphosphorylation and delayed dephosphorylation of the critical tyrosine residue at position 701 (pY701) has been observed in cytokine-stimulated cells from many patients with STAT1-GOF mutations and can be measured by flow cytometry.<sup>47</sup> Unfortunately, the utility of this assay as a screening test to identify patients with STAT1-GOF mutations is not yet clear, as it is not known whether the phosphorylation defect is consistent. As a result, sequencing of the *STAT1* gene remains the gold standard for diagnosis.

Treatment of CMC in this disorder typically requires chronic or intermittent antifungal therapy, with mixed success. Treatment of the IPEX-like autoimmunity requires aggressive immunosuppression although there has not been a regimen or class of agents that has shown consistent efficacy. Steroids, B cell depletion therapy, and T cell directed immunosuppression (tacrolimus, cyclosporine, etc.) have all been utilized with varying results. Bone marrow transplantation (BMT) using a matched sibling donor and a reduced intensity conditioning regimen has been reported in one Peruvian patient, with transient clinical improvement, but the patient ultimately died of a

presumed respiratory infection following graft rejection.<sup>49</sup> At least three other patients with STAT1-GOF mutations have undergone successful BMT but are not yet reported suggesting BMT may be a viable approach in patients with severe disease.

## Defects in IL-2 Signaling

Since the realization that mice lacking CD25 (the  $\alpha$ -chain of the IL-2 receptor) have a phenotype similar to *Foxp3*<sup>-/-</sup> mice, there has been a suspicion that defects that blunt IL-2 signaling in T cells might lead to an IPEX-like presentation in humans (Figure 13-2).

### CD25 DEFICIENCY

Three unrelated patients with CD25 deficiency (OMIM #606367) have now been described. Similar to IPEX, all three patients developed severe, chronic diarrhea and villous atrophy in infancy (1 month, 6 weeks and 8 months of age).<sup>50-52</sup> Two of the patients developed endocrinopathies including early-onset

type 1 diabetes and thyroiditis and two developed significant skin disease including eczema, pemphigus nodularis and psoriasisiform dermatitis.<sup>50-52</sup> All three patients developed autoantibodies, hepatosplenomegaly, lymphadenopathy and lymphocytic infiltrates in various organs indicative of ongoing immune dysregulation.<sup>50-54</sup> Unlike IPEX patients, serum IgE levels were either mildly elevated or normal.<sup>51,52</sup>

In addition to autoimmune features, all three CD25-deficient patients had infectious complications suggestive of a more extensive defect in cellular immunity (Box 13-4). Early-onset, recurrent CMV infections occurred in all patients although persistent thrush, candidal esophagitis, chronic gastroenteritis, *Pseudomonas*, staphylococcal and EBV infections were also seen.<sup>50-53</sup> One patient even failed to reject an allogeneic skin graft.<sup>55</sup>

### Genetics and Immunopathogenesis

Inheritance is autosomal recessive leading to a complete lack of CD25 protein expression on activated T cells. Mutations included a homozygous four base pair deletion in the coding region of *CD25*, a homozygous mutation resulting in a single amino-acid substitution (p.S166N) and a compound heterozygous mutation.<sup>50-54</sup>

Recent studies in *Cd25*<sup>-/-</sup> mice have demonstrated that T<sub>REG</sub> cell development is normal. These cells have normal suppressive function in vitro but survival, maintenance and competitive fitness of the mature T<sub>REG</sub> cells is abnormal resulting in immune dysregulation.<sup>55-57</sup> Future efforts to assess T<sub>REG</sub> cells in CD25-deficient patients should help to determine whether a similar mechanism is at play in humans.

### Diagnosis and Treatment

All patients described to date lacked CD25 expression on T cells, suggesting that flow cytometry is an effective screening tool. Sequencing of the *CD25* gene is, however, recommended to confirm the diagnosis.

Because of the 'SCID-like' features of this syndrome, one patient underwent a successful bone marrow transplant from a matched sibling donor and has done well.<sup>53,54</sup> It is possible, however, that patients may respond to IL-2 therapy via the remaining low-affinity IL-2 receptor since the T cell proliferative defect was corrected in one patient ex vivo with high dose IL-2 or IL-15.

### STAT5B DEFICIENCY

Deficiency of the STAT5B transcription factor (OMIM #245590) causes a rare autosomal recessive disorder reported in only a handful of patients.<sup>58-60</sup> STAT5B mediates signaling from the human growth factor receptors such that clinical features include dwarfism, prominent forehead, saddle nose and

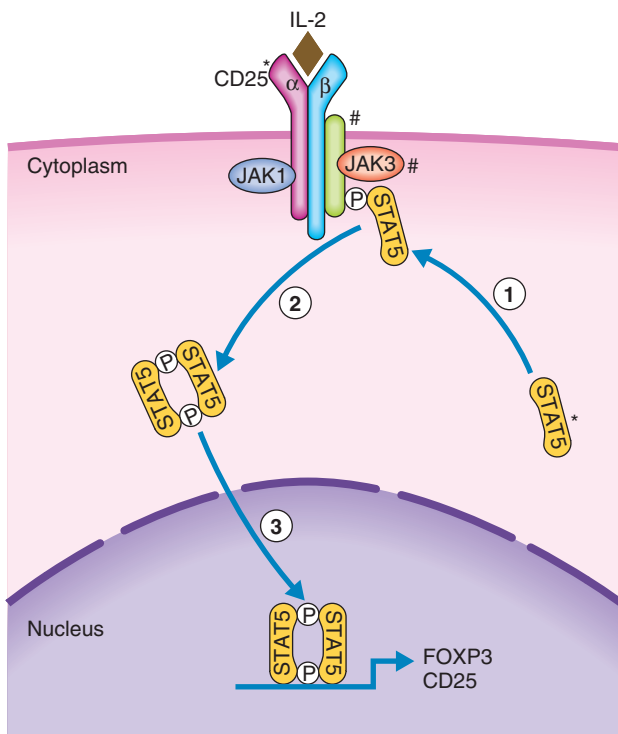

**Figure 13-2** The role of CD25 and STAT5b in the IL-2 signaling pathway. The illustration demonstrates the relative positions of CD25 and STAT5 (marked by \*) in the IL-2 signaling pathway. Binding of IL-2 to the IL-2 receptor (made up of an  $\alpha$ -chain [CD25], a  $\beta$ -chain and a  $\gamma$ -chain [ $\gamma$ ]) causes cross-phosphorylation of receptor chains on tyrosine by receptor-associated JAK1 and JAK3 kinases. Unphosphorylated STAT5 binds to phosphotyrosine residues on the activated receptor using its SH2 domain (1). STAT5 is then phosphorylated on tyrosine by the JAK kinases and released from the receptor where it dimerizes through binding of the SH2 domain on one subunit to the phosphotyrosine residue on the adjacent subunit and vice versa (2). Dimerized STAT5 accumulates in the nucleus where it directly binds to specific sites in the FOXP3 and CD25 promoters causing sustained expression of these two proteins in regulatory T cells (3). In contrast to deficiency in CD25 and STAT5b which causes an IPEX-like phenotype, mutations in the IL-2 receptor gamma chain or in JAK3 (both marked with #) cause a phenotype of severe combined immunodeficiency (SCID).

### BOX 13-4 KEY CONCEPTS

#### IMMUNOPATHOGENESIS OF CD25 DEFICIENCY

- Autoimmunity: IPEX-like enteropathy and endocrinopathies, a result of regulatory T cell dysfunction
- Immunodeficiency: mild to moderate T cell lymphopenia and poor T cell proliferative responses in vitro associated with recurrent/chronic viral infections

a high-pitched voice. Since STAT5B is also the primary transcription factor that mediates IL-2 stimulated gene transcription in T cells, most patients also have a marked immunodeficiency, with recurrent varicella virus, herpes virus and *Pneumocystis jiroveci* infections (Figure 13-2).<sup>59-61</sup>

In addition to immunodeficiency, most patients also have symptoms suggestive of immune dysregulation including chronic, early-onset diarrhea, eczema and lymphocytic interstitial pneumonitis (Box 13-5).<sup>58-60</sup> Mice lacking Stat5b have a significant reduction in the number of Foxp3<sup>+</sup> T<sub>REG</sub> cells in thymus and spleen, resulting in splenomegaly and a marked increase of activated T cells in the periphery.<sup>62-64</sup>

### Genetics and Immunopathogenesis

Two patients have been studied for the effect of STAT5B deficiency on T<sub>REG</sub> cells. One had a homozygous missense mutation (A630P) and the second had a homozygous nonsense mutation (R152X). Both mutations resulted in markedly reduced or absent STAT5B expression.<sup>63,65</sup> These patients had significantly fewer CD4<sup>+</sup>CD25<sup>high</sup> cells than normal controls, FOXP3 expression was decreased and the cells had no in vitro suppressive activity.<sup>59,65</sup> In addition, decreased CD25 expression (~20% of normal) was observed following T cell activation and is thought to synergize with the underlying STAT5B mutation to effectively abrogate IL-2 signals required for the maintenance of FOXP3 expression and T<sub>REG</sub> function. Interestingly, signaling pathways required for

IL-2 induced expression of other effector molecules, such as perforin, remained intact in STAT5B-deficient T cells.<sup>65</sup>

### Diagnosis and Treatment

Diagnosis of STAT5B deficiency is suspected in patients with the overt physical features of dwarfism combined with a significant immunodeficiency. Patients typically have normal serum growth hormone levels but very low insulin-like growth factor 1 (IGF-1) levels.<sup>63,64</sup> Immunologically, patients generally have low NK cell numbers and modest T cell lymphopenia.<sup>59,65</sup> Sequencing of the *STAT5B* gene should be done to confirm the diagnosis.

Treatment of patients with STAT5B deficiency is generally focused on symptomatic therapy and prophylaxis against infections. There are no published reports of bone marrow transplantation (BMT) for STAT5B deficiency although murine studies demonstrate that BMT is curative in mice lacking Stat5a/5b, suggesting that this would correct the immune deficiency and dysregulation but not the growth abnormalities.<sup>66</sup>

## Autoimmune Lymphoproliferative Syndrome

Initial reports of patients presenting with lymphadenopathy and hepatosplenomegaly associated with autoimmune cytopenias and increased gammaglobulins were followed 25 years later by a report that identified similar patients also noted to have a marked increase in circulating  $\alpha/\beta$ -TCR<sup>+</sup>CD3<sup>+</sup>CD4<sup>-</sup>CD8<sup>-</sup> T cells. These  $\alpha/\beta$  double negative T (DNT) cells normally constitute less than 1.5% of peripheral blood lymphocytes in adults (Figure 13-3).<sup>67,68</sup> The combination of findings led to the suggestion that this could represent the human equivalent to the *lpr* and *gld* murine models of autoimmunity.<sup>68</sup>

Following the discovery that mutations in the genes encoding FAS and FAS ligand caused disease in the murine autoimmunity models, two studies identified heterozygous *FAS* (*TNFRSF6*) mutations in these patients, yielding the term autoimmune lymphoproliferative syndrome (ALPS) to describe this disorder.<sup>69,70</sup> An increasing number of patients with mutations

### BOX 13-5 KEY CONCEPTS

#### IMMUNOPATHOGENESIS OF STAT5B DEFICIENCY

- Growth abnormalities: dwarfism due to growth hormone insensitivity (growth hormone levels normal but insulin-like growth factor 1 levels very low)
- Autoimmunity: IPEX-like enteropathy plus other autoimmunity (particularly pulmonary) as a result of low regulatory T cell numbers
- Immunodeficiency: mild to moderate T and NK cell deficiency associated with recurrent/chronic viral and fungal infections

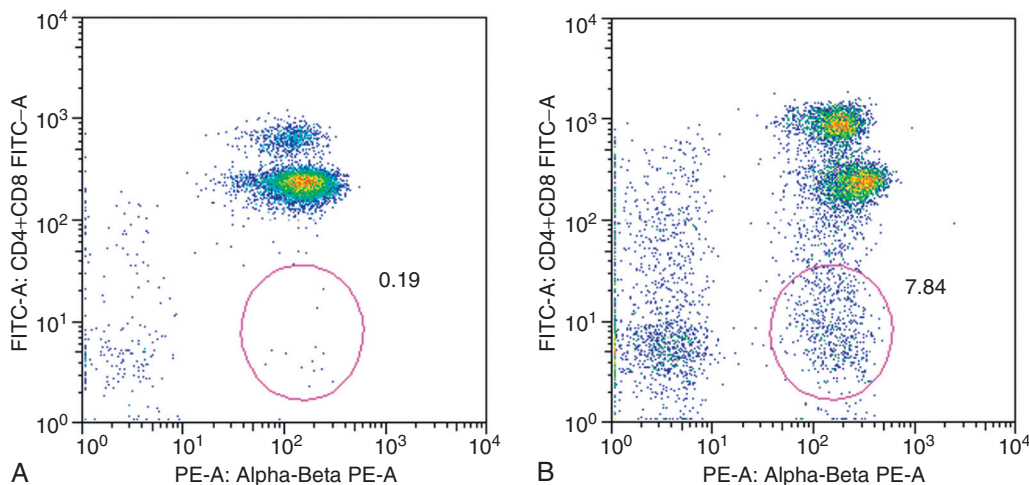

**Figure 13-3** Double negative T cells in ALPS. Flow cytometric evaluation of peripheral blood from a control patient (A) and an ALPS patient (B) demonstrating the increase of mature lymphocytes expressing the T cell receptor  $\alpha/\beta$  (X axis), that lack CD4 and CD8 co-receptor expression (Y axis) in ALPS.



in *FAS* have been identified, including some patients originally described by Canale and Smith.<sup>71</sup> However, patients with features of ALPS have been found without germline *FAS* mutations in whom defects in *FASL* (FASLG) or the intracellular apoptotic protein, caspase 10 (CASP10), were identified.<sup>72,73</sup> Additionally, somatic mutations primarily in  $\alpha/\beta$  DNT cells have been found in patients who presented with clinical ALPS without germline *FAS* mutations.<sup>74,75</sup> Additional patients who present with some ALPS features but additional distinctive features have been characterized with somatic defects in the *NRAS* and *KRAS* genes, a disorder associated with defective intrinsic, mitochondria-mediated lymphocyte apoptosis.<sup>76,77</sup> A small group of ALPS-like patients also have been identified with mutations in the gene encoding caspase 8 associated with features of immunodeficiency and now referred to as caspase eight deficiency state (CEDS).<sup>78</sup> Finally, there remain patients with an ALPS-like phenotype who have none of the defined genetic defects.

The typical clinical course in ALPS (OMIM #601859) begins within the first 5 years of life with nonmalignant, noninfectious peripheral lymphadenopathy.<sup>79–81</sup> This is often associated with splenomegaly and hypersplenism (Figure 13-4) that has been treated with splenectomy (no longer recommended due to the unusually high risk for *S. pneumoniae* related systemic infection).<sup>81</sup> Clinically apparent autoimmunity is seen in about 50% of the patients, most commonly presenting as Coombs positive



**Figure 13-4** Lymphoid accumulation in ALPS. Positron emission tomography demonstrating increasing fluorodeoxyglucose uptake on cervical, axillary and inguinal lymph nodes as well as an enlarged spleen in ALPS.

autoimmune hemolytic anemia either alone or together with autoimmune thrombocytopenia. Some ALPS patients may also develop neutropenia that is either immunologically mediated or secondary to hypersplenism. Dermatologic findings seen in ALPS most commonly include urticarial rashes. Infrequent autoimmune disorders include glomerulonephritis, polyneuropathy, autoimmune hepatitis and Guillain-Barré syndrome. A life-threatening ALPS manifestation is the dramatically increased incidence of lymphoma with germline *FAS* mutations. The increased relative risk is 149 for Hodgkin's disease and 61 for non-Hodgkin's lymphomas (Box 13-6).<sup>81</sup>

The laboratory findings in ALPS are summarized in Box 13-7. Immunophenotyping reveals expansion of  $\alpha/\beta$  DNT cells, often together with lymphocytosis. Other frequent abnormalities include an expansion of HLA-DR<sup>+</sup> and a decrease in the CD25<sup>+</sup> T cells plus very low numbers of CD20<sup>+</sup>CD27<sup>+</sup> (memory) B cells.<sup>82</sup> A polyclonal increase in serum immunoglobulins is often observed, usually involving IgG and/or IgA. Autoantibodies directed against platelets and neutrophils not linked to the degree of cytopenias, as well as anti-phospholipid antibodies, are present in 70–80% of the patients.<sup>83</sup> IL-10 is markedly elevated in the serum of ALPS patients; that is at least in part from the  $\alpha/\beta$  DNT cells and circulating monocytes.<sup>84</sup> More recently, elevated serum IL-18, soluble FASLG and vitamin B<sub>12</sub> levels have been found. In the presence of elevated  $\alpha/\beta$  DNT cells, these biomarkers strongly correlate with the presence of *FAS* mutations.<sup>85,86</sup> Histologically, the enlarged lymph nodes in ALPS show follicular hyperplasia and marked paracortical expansion with infiltrating  $\alpha/\beta$ -DNT cells, immunoblasts and plasma cells.<sup>87</sup>

#### BOX 13-6 KEY CONCEPTS

##### IMMUNOPATHOGENESIS OF AUTOIMMUNE LYMPHOPROLIFERATIVE SYNDROME

- Lymphadenopathy: persistence of lymphocytes that normally would die
- Autoimmunity: failure to eliminate autoreactive lymphocytes
- Lymphoma: inability to eliminate lymphocyte oncogenic mutations

#### BOX 13-7 LABORATORY FINDINGS IN AUTOIMMUNE LYMPHOPROLIFERATIVE SYNDROME

##### IMMUNOLOGIC

###### Lymphocytes

Increase:  $\alpha/\beta$  double negative T cells, CD8 T cells, B cells

Decrease: CD4/CD25 T cells, CD27<sup>+</sup> B cells

Immunoglobulins: increased IgG, IgA, and IgE

Cytokines: increased levels of serum IL-10, IL-18

Increased soluble FAS ligand

Autoantibodies: directed at blood cells

##### HEMATOLOGIC

Lymphocytosis

Anemia

Thrombocytopenia

Neutropenia

Eosinophilia

##### CHEMISTRY

Increased vitamin B<sub>12</sub> level

## GENETICS AND IMMUNOPATHOGENESIS

The majority of ALPS patients have germline heterozygous *FAS* mutations with the majority affecting the intracellular domains of the gene (~73%) while a smaller number impact the transmembrane domains (~6%) and the extracellular domains (~21%).<sup>79,81,88</sup> The site of the mutation has a direct impact on the development of disease manifestation with mutations in the intracellular *FAS* domains correlating with higher penetrance and more severe clinical manifestations.<sup>89</sup> The intracellular mutations typically act in a dominant negative manner while extracellular mutations not affecting the pre-ligand assembly domain usually result in haploinsufficiency.<sup>90,91</sup>

Recently, somatic *FAS* mutations, detected primarily in  $\alpha/\beta$  DNT cells, have been described in a number of patients with sporadic ALPS.<sup>74,75</sup> A minority of ALPS patients do not have germline or somatic *FAS* mutations. Evaluation of the gene encoding FASLG identified two patients with typical findings of ALPS associated with heterozygous mutations while homozygous *FASLG* mutations have been found in a limited number of patients with a severe ALPS phenotype.<sup>76,92,93</sup> Likewise, a small number of patients have been demonstrated to have a defect in the intracellular apoptotic protein, caspase 10 (Figure 13-5).<sup>72</sup> Recent work has identified somatic *NRAS* and *KRAS* mutations in patients with some ALPS features that are associated with an intrinsic pathway apoptotic abnormality. This group of patients is now classified separately as RAS-associated autoimmune leukoproliferative disease (RALD).<sup>76,77,94</sup> The current classification scheme for ALPS is:<sup>94</sup>

- ALPS-FAS: germline mutation in the gene encoding *FAS* (*TNFRSF6*)

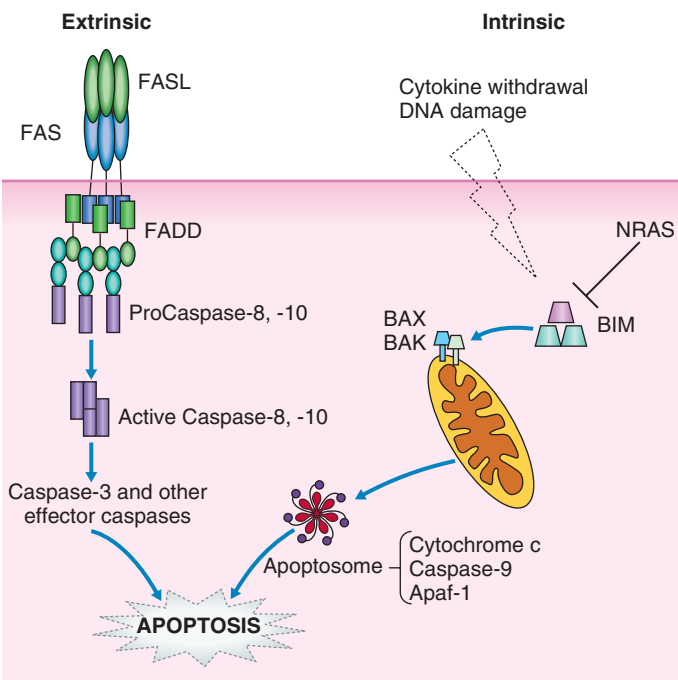

**Figure 13-5** Lymphocyte apoptosis pathways. Lymphocytes have two main pathways of apoptosis, regulated either by surface receptors of the TNF superfamily (extrinsic pathway) or proteins of the BCL-2 family (intrinsic pathway). The majority of ALPS patients have a defect in the extrinsic pathway involving *FAS* but some ALPS patients also have been reported with a defect in the intrinsic pathway.

- ALPS-sFAS: somatic mutation in the gene encoding *FAS* (*TNFRSF6*)
- ALPS-FASLG: mutation in the gene encoding *FAS* ligand (*TNFSF6*)
- ALPS-CASP: mutation in the gene encoding caspase 10 (*CASP10*)
- ALPS-U: unknown, no known mutation.

## DIAGNOSIS AND TREATMENT

The initial presentation of lymphadenopathy often raises the issue of malignancy that generally requires a biopsy to differentiate. The initial findings can also be suggestive of a chronic viral infection such as Epstein-Barr virus (Box 13-8), although there is no evidence to support a role for EBV. The autoimmunity seen in ALPS patients is most commonly directed against erythrocytes and platelets. The laboratory findings associated with the autoimmunity do not distinguish ALPS patients from those who do not have this disorder.

The diagnostic triad for ALPS is nonmalignant, noninfectious lymphoaccumulation, defective *in vitro* *FAS*-mediated lymphocyte apoptosis, and increased levels of  $\alpha/\beta$  DNT cells (Box 13-9). Flow cytometric evaluation of peripheral blood lymphocytes is necessary to evaluate for increased levels of  $\alpha/\beta$  DNT cells (Box 13-7). The assessment of *FAS*-mediated lymphocyte apoptosis or identification of a *FAS* mutation (or other ALPS associated genetic defect) is required to establish this diagnosis. Mutation analysis should begin with *FAS* as the most common finding but if these studies are unrevealing, the next step when biomarkers are positive is purification of  $\alpha/\beta$  DNT cells for *FAS* sequencing to exclude somatic mutations. If these studies also are negative, the genes encoding FASLG and caspase 10 should be sequenced. As previously noted, there remain patients who meet the criteria for diagnosis of ALPS without defined genetic abnormalities (ALPS-U).

The lymphoid expansion typically diminishes with age, thus therapy directed at this is generally not necessary. Splenomegaly is often associated with hypersplenism, but splenectomy should

### BOX 13-8 KEY CONCEPTS

#### AUTOIMMUNE LYMPHOPROLIFERATIVE SYNDROME DIFFERENTIAL DIAGNOSIS

- Lymphoid malignancy
- Chronic viral infection
- Primary autoimmune hemolytic anemia
- Primary idiopathic thrombocytopenic purpura

### BOX 13-9 KEY CONCEPTS

#### DIAGNOSTIC CRITERIA FOR AUTOIMMUNE LYMPHOPROLIFERATIVE SYNDROME

##### Required

- Nonmalignant lymphadenopathy
- Increased percentage and/or numbers of  $\alpha/\beta$  T cell receptor double negative T cells
- Defective *in vitro* lymphocyte apoptosis

##### Supportive

- Autoimmune disease
- Family history

be discouraged owing to the significant risk of infections post splenectomy.<sup>81</sup> The autoimmune cytopenias typically respond to corticosteroids, which also decrease lymphadenopathy (rapidly reappears after discontinuing therapy). Exacerbations are not uncommon in some patients who may become resistant to conventional therapy. Mycophenolate mofetil can be useful in thrombocytopenic patients unresponsive to conventional therapy<sup>95,96</sup> and rituximab has proven useful when mycophenolate mofetil is ineffective.<sup>96</sup> Finally, rapamycin has been used experimentally with improvement in lymphadenopathy as well as control of autoimmunity.<sup>97</sup> Importantly, the increased risk for the development of lymphoma appears to be lifelong and careful vigilance is required to monitor all individuals with germline *FAS* mutations.

## RAS Associated Autoimmunity Lymphoproliferative Disorder

From a clinical standpoint, there exist a number of patients with some ALPS features but without defects in the *FAS* pathway. The genetic basis in some of these patients was established with the description of a patient whose disorder was caused by a somatic *NRAS* mutation.<sup>76</sup> The patient had persistent splenomegaly, minimally increased  $\alpha/\beta$  DNTs, autoantibodies and a history of lymphoma. He also had unique features including a history of significant leukocytosis early in life, persistent monocytosis and lymph node histology without  $\alpha/\beta$  DNT cell infiltration. Later, similar patients were found to have heterozygous mutations in *KRAS*.<sup>77</sup> The disease was named RAS associated autoimmune leukoproliferative disorder (RALD).<sup>94</sup>

The age at diagnosis can vary between 1 and 47 years of life. RALD presents with a generally mild degree of peripheral lymphadenopathy, significant splenomegaly and autoimmune cytopenias. In some patients, a history of recurrent mild upper and lower respiratory tract infections can be elicited.<sup>76,77,98</sup> Unlike ALPS, patients with RALD have transient or persistent elevation in granulocytes and monocytes. Some RALD patients have a clinical and laboratory phenotype early in life similar to juvenile myelomonocytic leukemia (JMML). However, unlike patients with JMML, the clinical course is chronic and benign. Immunophenotyping reveals mild to no elevation in  $\alpha/\beta$  DNTs and an expansion of B cells with normal or modestly decreased total lymphocyte numbers. Autoantibodies are typically detected including anti-nuclear antibodies, rheumatoid factor, anti-phospholipid, anti-cardiolipin, anti-platelet, anti-neutrophil and/or anti-red cell antibodies.<sup>76,77,98</sup> ALPS biomarkers are normal, as is *in vitro* *FAS*-induced apoptosis. In contrast, RALD patients demonstrate *ex vivo* T cell resistance to IL-2 withdrawal-induced cell death, pointing to a fundamentally different apoptotic defect.<sup>76,77</sup> The histopathologic findings include nonspecific polyclonal plasmacytosis with reactive secondary follicles, but without the typical paracortical expansion with  $\alpha/\beta$  DNT cells in ALPS. It is not known if these patients are at increased risk

for hematological malignancy although there is one case report of a RALD patient developing juvenile myelomonocytic leukemia.<sup>99</sup>

All 12 patients with RALD in the NIH cohort harbor somatic, gain-of-function mutations in *KRAS* or *NRAS*, which are present only in blood cells. These mutations diminish RAS GTPase activity by over 300-fold and lock the molecule in an 'on' position.<sup>100</sup> This permanent activation state increases cell signaling through the RAS-ERK pathway, inducing apoptotic defects and increased cell proliferation.<sup>76,77,98</sup>

## Protein Kinase C Delta Deficiency

An ALPS-like patient with lymphadenopathy, splenomegaly, multiple autoantibodies and elevated IgG was found to have a homozygous loss of function mutation in the gene encoding protein kinase C delta (*PKC $\delta$* ).<sup>101</sup> The mutation resulted in *ex vivo* B cell hyperproliferation and the lymph node histology of intense follicular hyperplasia and progressive transformation of germinal centers. Both of these findings mirror the *PKC $\delta$*  knockout mouse model. The defect also altered NK cell function, causing chronic EBV infection. Flow cytometry demonstrated expansion of CD5<sup>+</sup>CD20<sup>+</sup> B cells and mild elevation of  $\alpha/\beta$  DNT cells that were not present in the lymph nodes. This patient responded to rapamycin therapy with marked decrease in splenomegaly and hyperglobulinemia. An additional report identified a second patient with a homozygous loss of function *PKC $\delta$*  mutation who presented with a somewhat different clinical phenotype.<sup>102</sup> Additionally, three children from one consanguineous family have been reported with homozygous loss of function *PKC $\delta$*  mutations linked to mendelian systemic lupus erythematosus.<sup>103</sup> Taken together, these findings suggest that *PKC $\delta$*  plays a central role in B cell tolerance and prevention of self reactivity.

## Conclusions

In recent years, identification of the genetic defects linked to patients with congenital systemic autoimmunity has led to the definition of a new class of PIDD (primary immunodeficiency disease) in which the defect impacts the regulatory compartment of the immune system. Lessons learned from these disorders have clarified aspects of thymic selection, T<sub>REG</sub> function, *FAS* mediated apoptosis and intrinsic apoptosis mediated via RAS proteins. There are a number of unresolved issues that include defining other contributing genetic and/or environmental factors and clarifying the basis for the specific patterns of autoimmunity seen in these disorders. Studying these experiments of nature will continue to be a fertile field of investigation over the coming years as we strive to uncover the basic mechanisms of immune tolerance.

The complete reference list can be found on the companion Expert Consult website at <http://www.expertconsult.inkling.com>.

## KEY REFERENCES

- Kekäläinen E, Tuovinen H, Joensuu J, Gylling M, Franssila R, Pöntynen N, et al. A defect of regulatory T cells in patients with autoimmune polyendocrinopathy-candidiasis-ectodermal dystrophy. *J Immunol* 2007;178:1208–15.
- Puel A, Döffinger R, Natividad A, Chrabieh M, Barcenás-Morales G, Picard C, et al. Autoantibodies against IL-17A, IL-17F, and IL-22 in patients with chronic mucocutaneous candidiasis and autoimmune polyendocrine syndrome type I. *J Exp Med* 2010;207:291–7.
- Torgerson TR, Ochs HD. Immune dysregulation, polyendocrinopathy, enteropathy, X-linked: forkhead box protein 3 mutations and lack of regulatory T cells. *J Allergy Clin Immunol* 2007;120:744–50.

48. Uzel G, Sampaio EP, Lawrence MG, Hsu AP, Hackett M, Dorsey MJ, et al. Dominant gain-of-function STAT1 mutations in FOXP3 wild-type immune dysregulation-polyendocrinopathy-enteropathy-X-linked-like syndrome. *J Allergy Clin Immunol* 2013;131:1611–23.
51. Caudy AA, Reddy ST, Chatila T, Atkinson JP, Verbsky JW. CD25 deficiency causes an immune dysregulation, polyendocrinopathy, enteropathy, X-linked-like syndrome, and defective IL-10 expression from CD4 lymphocytes. *J Allergy Clin Immunol* 2007;119:482–7.
59. Bernasconi A, Marino R, Ribas A, Rossi J, Ciaccio M, Oleastro M, et al. Characterization of immunodeficiency in a patient with growth hormone insensitivity secondary to a novel STAT5b gene mutation. *Pediatrics* 2006;118:e1584–92.
77. Niemela JE, Lu L, Fleisher TA, Davis J, Caminha I, Natter M, et al. Somatic KRAS mutations associated with a human nonmalignant syndrome of autoimmunity and abnormal leukocyte homeostasis. *Blood* 2010;117:2883–6.
81. Price S, Shaw PA, Seitz A, Joshi G, Davis J, Niemela JE, et al. Natural history of autoimmune lymphoproliferative syndrome associated with FAS gene mutations. *Blood* 2014;123:1989–99.
94. Oliveira JB, Bleesing JJ, Dianzani U, Fleisher TA, Jaffe ES, Lenardo MJ, et al. Revised diagnostic criteria and classification of the autoimmune lymphoproliferative syndrome (ALPS): report from the 2009 NIH International Workshop. *Blood* 2010;116:e35–40.
101. Kuehn HS, Niemela JE, Rangel-Santos A, Zhang M, Pittaluga S, Stoddard JL, et al. Loss-of-function of the protein kinase C  $\delta$  (PKC $\delta$ ) causes a B-cell lymphoproliferative syndrome in humans. *Blood* 2013;121:3117–25.



## REFERENCES

- Halonen M, Eskelin P, Myhre AG, Perheentupa J, Husebye ES, Kämpe O, et al. AIRE mutations and human leukocyte antigen genotypes as determinants of the autoimmune polyendocrinopathy-candidiasis-ectodermal dystrophy phenotype. *J Clin Endocrinol Metab* 2002;87:2568–74.
- Perheentupa J. Autoimmune polyendocrinopathy-candidiasis-ectodermal dystrophy. *J Clin Endocrinol Metab* 2006;91:2843–50.
- Liston A, Lesage S, Wilson J, Peltonen L, Goodnow CC. Aire regulates negative selection of organ-specific T cells. *Nat Immunol* 2003;4:350–4.
- Anderson MS, Venanzi ES, Klein L, Chen Z, Berzins SP, Turley SJ, et al. Projection of an immunological self shadow within the thymus by the aire protein. *Science* 2002;298:1395–401.
- Aschenbrenner K, D'Cruz LM, Vollmann EH, Hinterberger M, Emmerich J, Swee LK, et al. Selection of Foxp3(+) regulatory T cells specific for self antigen expressed and presented by Aire(+) medullary thymic epithelial cells. *Nat Immunol* 2007;8:351–8.
- Kekäläinen E, Tuovinen H, Joensuu J, Gylling M, Franssila R, Pöntynen N, et al. A defect of regulatory T cells in patients with autoimmune polyendocrinopathy-candidiasis-ectodermal dystrophy. *J Immunol* 2007;178:1208–15.
- Alimohammadi M, Björklund P, Hallgren A, Pöntynen N, Szinnai G, Shikama N, et al. Autoimmune polyendocrine syndrome type 1 and NALP5, a parathyroid autoantigen. *N Engl J Med* 2008;358:1018–28.
- Shum AK, DeVoss J, Tan CL, Hou Y, Johannes K, O'Gorman CS, et al. Identification of an autoantigen demonstrates a link between interstitial lung disease and a defect in central tolerance. *Sci Transl Med* 2009;1:9–20.
- Oliva-Hemker M, Berkenblit GV, Anhalt GJ, Yardley JH. Pernicious anemia and widespread absence of gastrointestinal endocrine cells in a patient with autoimmune polyglandular syndrome type I and malabsorption. *J Clin Endocrinol Metab* 2006;91:2833–8.
- Meloni A, Furcas M, Cetani F, Marcocci C, Falorni A, Perniola R, et al. Autoantibodies against type I interferons as an additional diagnostic criterion for autoimmune polyendocrine syndrome type I. *J Clin Endocrinol Metab* 2008;93:4389–97.
- Puel A, Döffinger R, Natividad A, Chrabieh M, Barcenas-Morales G, Picard C, et al. Autoantibodies against IL-17A, IL-17F, and IL-22 in patients with chronic mucocutaneous candidiasis and autoimmune polyendocrine syndrome type I. *J Exp Med* 2010;207:291–7.
- Kisand K, Bøe Wolff AS, Podkrajsek KT, Tserel L, Link M, Kisand KV, et al. Chronic mucocutaneous candidiasis in APECED and thymoma patients correlates with autoimmunity to Th17-associated cytokines. *J Exp Med* 2010;207:299–308.
- Rautemaa R, Richardson M, Pfaller M, Perheentupa J, Saxen H. Reduction of fluconazole susceptibility of *Candida albicans* in APECED patients due to long-term use of ketoconazole and miconazole. *Scand J Infect Dis* 2008;40:904–7.
- Gavanescu I, Benoist C, Mathis D. B cells are required for Aire-deficient mice to develop multi-organ autoinflammation: A therapeutic approach for APECED patients. *Proc Natl Acad Sci U S A* 2008;105:13009–130014.
- Popler J, Alimohammadi M, Kämpe O, Dalin F, Dishop MK, Barker JM, et al. Autoimmune polyendocrine syndrome type 1: utility of KCNRG autoantibodies as a marker of active pulmonary disease and successful treatment with rituximab. *Pediatr Pulmonol* 2012;47:84–7.
- Powell BR, Buist NR, Stenzel P. An X-linked syndrome of diarrhea, polyendocrinopathy, and fatal infection in infancy. *J Pediatr* 1982;100:731–7.
- Levy-Lahad E, Wildin RS. Neonatal diabetes mellitus, enteropathy, thrombocytopenia, and endocrinopathy: further evidence for an X-linked lethal syndrome. *J Pediatr* 2001;138:577–80.
- Wildin RS, Smyk-Pearson S, Filipovich AH. Clinical and molecular features of the immunodysregulation, polyendocrinopathy, enteropathy, X linked (IPEX) syndrome. *J Med Genet* 2002;39:537–45.
- Nieves DS, Phipps RP, Pollock SJ, Ochs HD, Zhu Q, Scott GA, et al. Dermatologic and immunologic findings in the immune dysregulation, polyendocrinopathy, enteropathy, X-linked syndrome. *Arch Dermatol* 2004;140:466–72.
- McGinness JL, Bivens MM, Greer KE, Patterson JW, Saulsbury FT. Immune dysregulation, polyendocrinopathy, enteropathy, X-linked syndrome (IPEX) associated with pemphigoid nodularis: a case report and review of the literature. *J Am Acad Dermatol* 2006;55:143–8.
- Torgerson TR, Ochs HD. Immune dysregulation, polyendocrinopathy, enteropathy, X-linked: forkhead box protein 3 mutations and lack of regulatory T cells. *J Allergy Clin Immunol* 2007;120:744–50.
- Chatila TA, Blaese R, Ho N, Lederman HM, Voulgaropoulos C, Helms C, et al. JM2, encoding a fork head-related protein, is mutated in X-linked autoimmunity-allergic dysregulation syndrome. *J Clin Invest* 2000;106:R75–81.
- Bennett CL, Christie J, Ramsdell F, Brunkow ME, Ferguson PJ, Whitesell L, et al. The immune dysregulation, polyendocrinopathy, enteropathy, X-linked syndrome (IPEX) is caused by mutations of FOXP3. *Nat Genet* 2001;27:20–1.
- Wildin RS, Ramsdell F, Peake J, Faravelli F, Casanova JL, Buist N, et al. X-linked neonatal diabetes mellitus, enteropathy and endocrinopathy syndrome is the human equivalent of mouse scurfy. *Nat Genet* 2001;27:18–20.
- Gavin MA, Rasmussen JP, Fontenot JD, Vasta V, Manganiello VC, Beavo JA, et al. Foxp3-dependent programme of regulatory T-cell differentiation. *Nature* 2007;445:771–5.
- Lin W, Haribhai D, Relland LM, Truong N, Carlson MR, Williams CB, et al. Regulatory T cell development in the absence of functional Foxp3. *Nat Immunol* 2007;8:359–68.
- Gavin MA, Torgerson TR, Houston E, DeRoos P, Ho WY, Stray-Pedersen A, et al. Single-cell analysis of normal and FOXP3-mutant human T cells: FOXP3 expression without regulatory T cell development. *Proc Natl Acad Sci U S A* 2006;103:6659–64.
- Allan SE, Crome SQ, Crellin NK, Passerini L, Steiner TS, Bacchetta R, et al. Activation-induced FOXP3 in human T effector cells does not suppress proliferation or cytokine production. *Int Immunol* 2007;19:345–54.
- Pillai V, Ortega SB, Wang CK, Karandikar NJ. Transient regulatory T-cells: a state attained by all activated human T-cells. *Clin Immunol* 2007;123:18–29.
- Wang J, Ioan-Facsinay A, van der Voort EI, Huizinga TW, Toes RE. Transient expression of FOXP3 in human activated nonregulatory CD4+ T cells. *Eur J Immunol* 2007;37:129–38.
- Schubert LA, Jeffery E, Zhang Y, Ramsdell F, Ziegler SE. Scurfin (FOXP3) acts as a repressor of transcription and regulates T cell activation. *J Biol Chem* 2001;276:37672–9.
- Bettelli E, Dastrange M, Oukka M. Foxp3 interacts with nuclear factor of activated T cells and NF-kappa B to repress cytokine gene expression and effector functions of T helper cells. *Proc Natl Acad Sci U S A* 2005;102:5138–43.
- Wu Y, Borde M, Heissmeyer V, Feuerer M, Lapan AD, Stroud JC, et al. FOXP3 controls regulatory T cell function through cooperation with NFAT. *Cell* 2006;126:375–87.
- Zheng Y, Josefowicz SZ, Kas A, Chu TT, Gavin MA, Rudensky AY. Genome-wide analysis of Foxp3 target genes in developing and mature regulatory T cells. *Nature* 2007;445:936–40.
- Marson A, Kretschmer K, Frampton GM, Jacobsen ES, Polansky JK, MacIsaac KD, et al. Foxp3 occupancy and regulation of key target genes during T-cell stimulation. *Nature* 2007;445:931–5.
- Lopes JE, Torgerson TR, Schubert LA, Anover SD, Ocheltree EL, Ochs HD, et al. Analysis of FOXP3 reveals multiple domains required for its function as a transcriptional repressor. *J Immunol* 2006;177:3133–42.
- Ono M, Yaguchi H, Ohkura N, Kitabayashi I, Nagamura Y, Nomura T, et al. Foxp3 controls regulatory T-cell function by interacting with AML1/Runx1. *Nature* 2007;446:685–9.
- Blair PJ, Bultman SJ, Haas JC, Rouse BT, Wilkinson JE, Godfrey VL. CD4+CD8- T cells are the effector cells in disease pathogenesis in the scurfy (sf) mouse. *J Immunol* 1994;153:3764–74.
- Ferguson PJ, Blanton SH, Saulsbury FT, McDuffie MJ, Lemahieu V, Gastier JM, et al. Manifestations and linkage analysis in X-linked autoimmunity-immunodeficiency syndrome. *Am J Med Genet* 2000;90:390–7.
- Bindl L, Torgerson T, Perroni L, Youssef N, Ochs HD, Goulet O, et al. Successful use of the new immune-suppressor sirolimus in IPEX (immune dysregulation, polyendocrinopathy, enteropathy, X-linked syndrome). *J Pediatr* 2005;147:256–9.
- Kobayashi I, Nakanishi M, Okano M, Sakiyama Y, Matsumoto S. Combination therapy with tacrolimus and betamethasone for a patient with X-linked auto-immune enteropathy. *Eur J Pediatr* 1995;154:594–5.
- Taddio A, Faleschini E, Valencic E, Granzotto M, Tommasini A, Lepore L, et al. Medium-term survival without haematopoietic stem cell transplantation in a case of IPEX: insights into nutritional and immunosuppressive therapy. *Eur J Pediatr* 2007;166:1195–7.
- Mazzolari E, Forino C, Fontana M, D'Ippolito C, Lanfranchi A, Gambineri E, et al. A new case of IPEX receiving bone marrow trans-

- plantation. *Bone Marrow Transplant* 2005;35:1033–4.
44. Lucas KG, Ungar D, Comito M, Bayerl M, Groh B. Submyeloablative cord blood transplantation corrects clinical defects seen in IPEX syndrome. *Bone Marrow Transplant* 2007;39:55–6.
  45. Rao A, Kamani N, Filipovich A, Lee SM, Davies SM, Dalal J, et al. Successful bone marrow transplantation for IPEX syndrome after reduced-intensity conditioning. *Blood* 2007;109:383–5.
  46. van de Veerdonk FL, Plantinga TS, Hoischen A, Smeekens SP, Joosten LA, Gilissen C, et al. STAT1 mutations in autosomal dominant chronic mucocutaneous candidiasis. *N Engl J Med* 2011;365:54–61.
  47. Liu L, Okada S, Kong XF, Kreins AY, Cypowyj S, Abhyankar A, et al. Gain-of-function human STAT1 mutations impair IL-17 immunity and underlie chronic mucocutaneous candidiasis. *J Exp Med* 2011;208:1635–48.
  48. Uzel G, Sampaio EP, Lawrence MG, Hsu AP, Hackett M, Dorsey MJ, et al. Dominant gain-of-function STAT1 mutations in FOXP3 wild-type immune dysregulation-polyendocrinopathy-enteropathy-X-linked-like syndrome. *J Allergy Clin Immunol* 2013;131:1611–23.
  49. Aldave JC, Cachay E, Núñez L, Chunga A, Murillo S, Cypowyj S, et al. A 1-year-old girl with a gain-of-function STAT1 mutation treated with hematopoietic stem cell transplantation. *J Clin Immunol* 2013;33:1273–5.
  50. Goudy K, Aydin D, Barzaghi F, Gambineri E, Vignoli M, Ciullini Mannurita S, et al. Human IL2RA null mutation mediates immunodeficiency with lymphoproliferation and autoimmunity. *Clin Immunol* 2013;146:248–61.
  51. Caudy AA, Reddy ST, Chatila T, Atkinson JP, Verbsky JW. CD25 deficiency causes an immune dysregulation, polyendocrinopathy, enteropathy, X-linked-like syndrome, and defective IL-10 expression from CD4 lymphocytes. *J Allergy Clin Immunol* 2007;119:482–7.
  52. Sharfe N, Dadi HK, Shahar M, Roifman CM. Human immune disorder arising from mutation of the alpha chain of the interleukin-2 receptor. *Proc Natl Acad Sci U S A* 1997;94:3168–71.
  53. Aoki CA, Roifman CM, Lian ZX, Bowlus CL, Norman GL, Shoenfeld Y, et al. IL-2 receptor alpha deficiency and features of primary biliary cirrhosis. *J Autoimmun* 2006;27:50–3.
  54. Roifman CM. Human IL-2 receptor alpha chain deficiency. *Pediatr Res* 2000;48:6–11.
  55. Fontenot JD, Rasmussen JP, Gavin MA, Rudensky AY. A function for interleukin 2 in Foxp3-expressing regulatory T cells. *Nat Immunol* 2005;6:1142–51.
  56. Willerford DM, Chen J, Ferry JA, Davidson L, Ma A, Alt FW. Interleukin-2 receptor alpha chain regulates the size and content of the peripheral lymphoid compartment. *Immunity* 1995;3:521–30.
  57. D'Cruz LM, Klein L. Development and function of agonist-induced CD25+Foxp3+ regulatory T cells in the absence of interleukin 2 signaling. *Nat Immunol* 2005;6:1152–9.
  58. Hwa V, Little B, Adiyaman P, Kofoed EM, Pratt KL, Ocal G, et al. Severe growth hormone insensitivity resulting from total absence of signal transducer and activator of transcription 5b. *J Clin Endocrinol Metab* 2005;90:4260–6.
  59. Bernasconi A, Marino R, Ribas A, Rossi J, Ciaccio M, Oleastro M, et al. Characterization of immunodeficiency in a patient with growth hormone insensitivity secondary to a novel STAT5b gene mutation. *Pediatrics* 2006;118:e1584–92.
  60. Kofoed EM, Hwa V, Little B, Woods KA, Buckway CK, Tsubaki J, et al. Growth hormone insensitivity associated with a STAT5b mutation. *N Engl J Med* 2003;349:1139–47.
  61. Kim HP, Imbert J, Leonard WJ. Both integrated and differential regulation of components of the IL-2/IL-2 receptor system. *Cytokine Growth Factor Rev* 2006;17:349–66.
  62. Yao Z, Kanno Y, Kerenyi M, Stephens G, Durant L, Watford WT, et al. Nonredundant roles for Stat5a/b in directly regulating Foxp3. *Blood* 2007;109:4368–75.
  63. Burchill MA, Goetz CA, Prlc M, O'Neil JJ, Harmon IR, Bensinger SJ, et al. Distinct effects of STAT5 activation on CD4+ and CD8+ T cell homeostasis: development of CD4+CD25+ regulatory T cells versus CD8+ memory T cells. *J Immunol* 2003;171:5853–64.
  64. Antov A, Yang L, Vig M, Baltimore D, Van Parijs L. Essential role for STAT5 signaling in CD25+CD4+ regulatory T cell homeostasis and the maintenance of self-tolerance. *J Immunol* 2003;171:3435–41.
  65. Cohen AC, Nadeau KC, Tu W, Hwa V, Dionis K, Bezrodnik L, et al. Cutting edge: decreased accumulation and regulatory function of CD4+ CD25(high) T cells in human STAT5b deficiency. *J Immunol* 2006;177:2770–4.
  66. Snow JW, Abraham N, Ma MC, Goldsmith MA. Bone marrow transplant completely rescues hematolymphoid defects in STAT5A/5B-deficient mice. *Exp Hematol* 2003;31:1247–52.
  67. Canale VC, Smith CH. Chronic lymphadenopathy simulating malignant lymphoma. *J Pediatr* 1967;70:891–9.
  68. Sneller MC, Straus SE, Jaffe ES, Jaffe JS, Fleisher TA, Stetler-Stevenson M, et al. A novel lymphoproliferative/autoimmune syndrome resembling murine lpr/gld disease. *J Clin Invest* 1992;90:334–41.
  69. Fisher GH, Rosenberg FJ, Straus SE, Dale JK, Middleton LA, Lin AY, et al. Dominant interfering Fas gene mutations impair apoptosis in a human autoimmune lymphoproliferative syndrome. *Cell* 1995;81:935–46.
  70. Rieux-Laucat F, Le Deist F, Hivroz C, Roberts IA, Debatin KM, Fischer A, et al. Mutations in Fas associated with human lymphoproliferative syndrome and autoimmunity. *Science* 1995;268:1347–9.
  71. Drappa J, Vaishnav AK, Sullivan KE, Chu JL, Elkon KB. Fas gene mutations in the Canale-Smith syndrome, an inherited lymphoproliferative disorder associated with autoimmunity. *N Engl J Med* 1996;335:1643–9.
  72. Wang J, Zheng L, Lobito A, Chan FK, Dale J, Sneller M, et al. Inherited human Caspase 10 mutations underlie defective lymphocyte and dendritic cell apoptosis in autoimmune lymphoproliferative syndrome type II. *Cell* 1999;98:47–58.
  73. Bi LL, Pan G, Atkinson TP, Zheng L, Dale JK, Makris C, et al. Dominant inhibition of Fas ligand-mediated apoptosis due to a heterozygous mutation associated with autoimmune lymphoproliferative syndrome (ALPS) Type Ib. *BMC Med Genet* 2007;8:41.
  74. Holzelova E, Vonarbourg C, Stolzenberg MC, Arkwright PD, Selz F, Prieur AM, et al. Autoimmune lymphoproliferative syndrome with somatic Fas mutations. *N Engl J Med* 2004;351:1409–18.
  75. Dowdell KC, Niemela JE, Price S, Davis J, Hornung RL, Oliveira JB, et al. Somatic Fas mutations are common in patients with genetically undefined autoimmune lymphoproliferative syndrome. *Blood* 2010;115:5164–9.
  76. Oliveira JB, Bidere N, Niemela JE, et al. NRAS mutation causes a human autoimmune lymphoproliferative syndrome. *Proc Natl Acad Sci U S A* 2007;104:8953–8.
  77. Niemela JE, Lu L, Fleisher TA, Davis J, Caminha I, Natter M, et al. Somatic KRAS mutations associated with a human nonmalignant syndrome of autoimmunity and abnormal leukocyte homeostasis. *Blood* 2010;117:2883–6.
  78. Chun HJ, Zheng L, Ahmad M, Wang J, Speirs CK, Siegel RM, et al. Pleiotropic defects in lymphocyte activation caused by caspase-8 mutations lead to human immunodeficiency. *Nature* 2002;419:395–9.
  79. Fleisher TA, Oliveira JB. Autoimmune lymphoproliferative syndrome. *Isr Med Assoc J* 2005;7:758–61.
  80. Neven B, Magerus-Chatinet A, Florkin B, Gobert D, Lambotte O, De Somer L, et al. A survey of 90 patients with autoimmune lymphoproliferative syndrome related to TNFRSF6 mutation. *Blood* 2011;118:4798–807.
  81. Price S, Shaw PA, Seitz A, Joshi G, Davis J, Niemela JE, et al. Natural history of autoimmune lymphoproliferative syndrome associated with Fas gene mutations. *Blood* 2014;123:1989–99.
  82. Bleesing JJ, Brown MR, Straus SE, Dale JK, Siegel RM, Johnson M, et al. Immunophenotypic profiles in families with autoimmune lymphoproliferative syndrome. *Blood* 2001;98:2466–73.
  83. Kwon SW, Procter J, Dale JK, Straus SE, Stroncek DF, et al. Neutrophil and platelet antibodies in autoimmune lymphoproliferative syndrome. *Vox Sang* 2003;85:307–12.
  84. Lopatin U, Yao X, Williams RK, Bleesing JJ, Dale JK, Wong D, et al. Increases in circulating and lymphoid tissue interleukin-10 in autoimmune lymphoproliferative syndrome are associated with disease expression. *Blood* 2001;97:3161–70.
  85. Magerus-Chatinet A, Stolzenberg MC, Loffredo MS, Neven B, Schaffner C, Ducrot N, et al. FAS-L, IL-10, and double-negative CD4-CD8- TCR alpha/beta+ T cells are reliable markers of autoimmune lymphoproliferative syndrome (ALPS) associated with Fas loss of function. *Blood* 2009;113:3027–30.
  86. Caminha I, Fleisher TA, Hornung RL, Dale JK, Niemela JE, Price S, et al. Using biomarkers to predict the presence of Fas mutations in patients with features of the autoimmune lymphoproliferative syndrome. *J Allergy Clin Immunol* 2010;124:946–9.
  87. Lim MS, Straus SE, Dale JK, Fleisher TA, Stetler-Stevenson M, Strober W, et al. Pathological findings in human autoimmune lymphoproliferative syndrome. *Am J Pathol* 1998;153:1541–50.
  88. Su HC, Lenardo MJ. Genetic defects of apoptosis and primary immunodeficiency. *Immunol Allergy Clin North Am* 2008;28:329–51.
  89. Jackson CE, Fischer RE, Hsu AP, Anderson SM, Choi Y, Wang J, et al. Autoimmune lymphoproliferative syndrome with defective Fas: genotype influences penetrance. *Am J Hum Genet* 1999;64:1002–14.

90. Kuehn HS, Caminha I, Niemela JE, Rao VK, Davis J, Fleisher TA, et al. Fas haploinsufficiency is a common disease mechanism in the human autoimmune lymphoproliferative syndrome. *J Immunol* 2011;186:6035–43.
91. Hsu AP, Dowdell KC, Davis J, Niemela JE, Anderson SM, Shaw PA, et al. Autoimmune lymphoproliferative syndrome due to FAS mutations outside the signal-transducing death domain: molecular mechanisms and clinical penetrance. *Genet Med* 2012;14:81–9.
92. Del-Rey M, Ruiz-Contreras J, Bosque A, Calleja S, Gomez-Rial J, Roldan E, et al. A homozygous Fas ligand gene mutation in a patient causes a new type of autoimmune lymphoproliferative syndrome. *Blood* 2006;108:1306–12.
93. Magerus-Chatinet A, Stolzenberg MC, Lanzarotti N, Neven B, Daussy C, Picard C, et al. Autoimmune lympho-proliferative syndrome caused by homozygous null FAS ligand (*FASLG*) mutation. *J Allergy Clin Immunol* 2013;131:486–90.
94. Oliveira JB, Bleesing JJ, Dianzani U, Fleisher TA, Jaffe ES, Lenardo MJ, et al. Revised diagnostic criteria and classification of the autoimmune lymphoproliferative syndrome (ALPS): report from the 2009 NIH International Workshop. *Blood* 2010;116:e35–40.
95. Rao VK, Dugan F, Dale JK, Davis J, Tretler J, Hurley JK, et al. Use of mycophenolate mofetil for chronic, refractory immune cytopenias in children with autoimmune lymphoproliferative syndrome. *Br J Haematol* 2005;129:534–8.
96. Rao VK, Oliveira JB. How I treat autoimmune lymphoproliferative syndrome. *Blood* 2011;118:5741–51.
97. Teachey DT. New advances in the diagnosis and treatment of autoimmune lympho-proliferative syndrome (ALPS). *Curr Opin Pediatr* 2012;24:1–8.
98. Takagi M, Shinoda K, Piao J, Mitsuiki N, Takagi M, Matsuda K, et al. Autoimmune lymphoproliferative syndrome-like disease with somatic *KRAS* mutation. *Blood* 2011;117:2887–90.
99. Lanzarotti N, Bruneau J, Trinquand A, Stolzenberg MC, Neven B, Fregeac J, et al. RAS-associated lymphoproliferative disease evolves into severe juvenile myelo-monocytic leukemia. *Blood* 2014;123:1960–3.
100. de Vos AM, Tong L, Milburn MV, Matias PM, Jancarik J, Noguchi S, et al. Three-dimensional structure of an oncogene protein: catalytic domain of human c-H-ras p21. *Science* 1988;239:888–93.
101. Kuehn HS, Niemela JE, Rangel-Santos A, Zhang M, Pittaluga S, Stoddard JL, et al. Loss-of-function of the protein kinase C  $\delta$  (*PKC $\delta$* ) causes a B-cell lymphoproliferative syndrome in humans. *Blood* 2013;121:3117–25.
102. Salzer E, Santos-Valente E, Klaver S, Ban SA, Emminger W, Prengemann NK, et al. B-cell deficiency and severe autoimmunity caused by deficiency of protein kinase C delta. *Blood* 2013;121:3112–16.
103. Belot A, Kasher PR, Trotter EW, Foray AP, Debaud AL, Rice GI, et al. Protein kinase  $c\delta$  deficiency cases mendelian systemic lupus erythematosus with B cell-defective apoptosis and hyperproliferation. *Arthritis Rheum* 2013;65:2161–71.

# Autoinflammatory Disorders

FATMA DEDEOGLU | SUSAN KIM

## KEY POINTS

- In the majority of the autoinflammatory diseases innate immune system dysregulation is the cause of the inflammation.
- Most of these conditions have a monogenic cause.
- Discovery of these genes leads to better understanding of the inflammatory pathways and the mechanisms of inflammation.
- These disorders both share common features such as fever, rash, serositis and musculoskeletal findings and also have disease-specific, unique features such as the type of rash, duration of fever and involved organ systems.
- Better understanding of the mechanisms of these conditions and the discovery of the genes have led to early recognition and better, more effective treatments with a subsequent decrease in morbidity and mortality and greatly improved outcomes and quality of life.

The finding of the ‘familial Mediterranean fever’ gene in 1997 triggered the discovery of additional genes and new inflammatory pathways, improving our understanding of inflammation and making possible more effective treatments in patients with these conditions. Periodic fever syndromes are now grouped under the term ‘autoinflammatory disorders’ (AD), a field which is a prime example of translational research and innovation.<sup>1-4</sup> Despite the achievement of significant milestones in this field, many questions remain unanswered, either due to complex and/or controversial genetic inheritance patterns (such as single mutation in a recessive disorder) or due to yet undiscovered pathways.

Unlike autoimmune conditions, autoantibodies or antigen-specific T cells are lacking, and monocytes and neutrophils are the major effector cells rather than lymphocytes. These syndromes are now considered inborn errors of innate immunity.<sup>5</sup>

Most of the known mutations found in AD involve proteins that modulate inflammation and apoptosis. Improved understanding of inflammatory pathways has led to the concept of autoinflammation, which now includes not only the monogenic conditions, such as familial Mediterranean fever (FMF), TNF receptor-associated periodic fever syndrome (TRAPS), familial cold autoinflammatory syndrome (FCAS) and mevalonate kinase deficiency (MKD – formerly known as hyper IgD syndrome-HIDS),<sup>2,6</sup> but also several polygenic and multifactorial conditions such as Crohn’s disease and systemic onset juvenile idiopathic arthritis (SoJIA). The boundary between the autoimmune (adaptive immunity) and the autoinflammatory

(innate immunity) diseases has become more obscure.<sup>7</sup> While immunodeficiencies with ‘immune dysregulation’ have been linked to AD, new autoinflammatory syndromes with features of immunodeficiency have also been described.<sup>2,6,8</sup>

Numerous attempts to group or classify autoinflammatory disorders have been made.<sup>3,9-11</sup> However, until we understand the inheritance patterns as well as the influence of the environment, epigenetic factors and their interactions, any classification modality will remain arbitrary or artificial. This chapter gives an overview of autoinflammatory disorders with a focus on the monogenic types.

## Common Features

Periodicity and fever are the cardinal features of many AD, but some may have a more chronic and/or afebrile course. The inflammatory response is typically localized to serosa, skin, eyes, lymph nodes and the musculoskeletal, gastrointestinal and nervous systems. The majority of AD present with recurrent episodes of inflammatory states, typically with fever and elevated inflammatory markers (C-reactive protein [CRP], erythrocyte sedimentation rate [ESR], serum amyloid A proteins [SAA]). Tables 14-1 and 14-2 summarize the typical features of these disorders. In addition, blood count abnormalities (leukocytosis, thrombocytosis, anemia) and elevated immunoglobulin levels are commonly seen. Patients are usually asymptomatic between the attacks, though in the severe forms longer duration of symptoms may occur.<sup>12,13</sup> Variability of features is seen within each syndrome, even within the same family. There may be a prodromal period with nonspecific features, such as fatigue and headaches.

When a patient presents with recurrent fevers, the differential remains broad and includes infectious, rheumatologic and oncologic/lymphoproliferative causes, as well as immunodeficiencies. The longer the period of repeated, stereotypical episodes, especially with fevers and systemic features affecting skin, mucosa, eyes, musculoskeletal, gastrointestinal and nervous systems, the greater the likelihood of an AD. Since the penetrance of the mutations is not 100% and de novo mutations may occur, a negative family history does not exclude a particular diagnosis. A family history of amyloidosis, chronic renal disease and deafness would strengthen the possibility.

When AD are considered, genetic testing may be helpful in confirming the diagnosis. However, up to 60% or more patients may have negative genetic testing, despite classic features consistent with a particular syndrome,<sup>13</sup> which could be a result of unknown genetic defects in the same inflammatory pathway, epigenetic factors, somatic mosaicism or phenotypic variability.

Genotype databases and other collaborative registries (e.g. Infefever: <http://fmf.igh.cnrs.fr/infefever>; Eurofever, EuroTRAPS) have been established and more than 1,000 sequence variants



**TABLE 14-1**  
**IL-1 Mediated Autoinflammatory Diseases**

	FCAS	MWS	NOMID	PAPA	DIRA	DITRA	FMF	MKD	NLRP12AD
Typical age	< 1 year	Variable, usually < 20 years	< 1 year	< 16 years	< 1 year	Variable	< 20 years	< 1 year	Unknown
Fever duration	1–2 days	1–3 days	Continuous	3–7 days	Continuous	Variable	1–3 days	3–7 days	5–10 days
Frequency	Based on cold exposure	1 month to continuous	Continuous	1–2 months	None to low-grade	High-grade	Variable	1–2 months	Based on cold exposure
Ethnic/cultural/regional predilection	Western European	Western European	Western European	Variable	Unknown	Unknown	Middle Eastern, Armenian, Turkish, Arab, Jewish	Western European	Unknown
Common clinical findings	Conjunctivitis, headache, arthralgia, myalgia, nausea	Conjunctivitis, uveitis, headache, deafness, arthralgia/arthritis, myalgia	Papilledema, uveitis, optic disc edema/vision loss, headache, aseptic meningitis, deafness, frontal bossing, epiphyseal overgrowth, mental retardation	Arthralgia, destructive arthritis	Osteomyelitis, periostitis, pustular skin lesions, hepatosplenomegaly, thrombosis,	Malaise, pustular skin lesions, pustular psoriasis	Serositis (peritonitis, pleuritis), monoarthritis, oligoarthritis, arthralgia	Lymph node enlargement, abdominal pain, vomiting, diarrhea, oral sores, arthralgia, splenomegaly, headache	Myalgia, arthralgia, fatigue, headaches, aphthous ulcers, abdominal pain
Skin manifestations	Urticarial rash	Urticarial rash	Urticarial rash	Pyoderma gangrenosum, cystic acne	Pustular skin lesions	Pustular psoriasis/skin lesions	Erysipeloid erythema	Maculopapular, nodular rash	Urticarial rash
Amyloidosis	Rare	30%	Rare	Not noted	Not noted	Not noted	Up to 75% (before colchicine)	Rare	Not noted
Inheritance	Autosomal dominant CIAS1/NLRP3, encoding cryopyrin	Autosomal dominant CIAS1/NLRP3, encoding cryopyrin	Autosomal dominant and de novo CIAS1/NLRP3, encoding cryopyrin	Autosomal dominant PSTPIP1	Autosomal recessive IL1RN and IL1 members	Autosomal dominant and de novo IL36RN and IL36	Autosomal recessive MEFV, encoding pyrin	Autosomal recessive MVK, encoding mevalonate kinase	AD NLRP12
Treatment	Anti-IL-1 therapy	Anti-IL-1 therapy	Anti-IL-1 therapy	Steroids and possibly anti-TNF therapy, anti-IL-1 therapy	Steroids anti-IL-1 therapy	Steroids anti-IL-1 therapy	Colchicine daily and possibly anti-IL-1 therapy	Steroids and possibly anti-TNF therapy, anti-IL-1 therapy, statins	Avoidance of cold, antihistamines, NSAIDs, and steroids

FCAS – familial cold autoinflammatory syndrome, MWS – Muckle-Wells syndrome, NOMID – neonatal onset multisystem inflammatory disease, PAPA – pyogenic sterile arthritis, pyoderma gangrenosum and acne, DIRA – deficiency of interleukin-1-receptor antagonist, DITRA – deficiency of IL-36 receptor antagonist, FMF – familial Mediterranean fever, MKD – mevalonate kinase deficiency, NLRP12AD – NLRP12-associated autoinflammatory disorder.

TABLE 14-2

Autoinflammatory Diseases Mediated Via Other Mechanisms

	Blau Syndrome	TRAPS	Majeed Syndrome	PFAPA	PRAAS/CANDLE/JMP/ JASL	SAVI	DADA2
Typical age	< 5 years	< 20 years	< 2 years	Preschool age	< 1 year	Infancy	< 5 years
Fever duration	Continuous	7+ days	3–4 days	3–5 days	Variable	Variable, low-grade	Variable
Frequency	Continuous	Variable	1–2 months	1 month	Variable	Variable	Intermittent fevers
Ethnic/cultural/ regional predilection	All	Western European	Arabic	All	Unknown	Unknown	Unknown
Common clinical findings	Granulomatous uveitis, arthritis, lymphadenopathy	Periorbital edema, conjunctivitis, arthralgia, migratory myalgia, serositis, abdominal pain	Deforming arthritis, growth retardation, osteomyelitis, hepatosplenomegaly	Stomatitis, pharyngitis, cervical lymph node enlargement, fatigue, headache	Joint contractures, muscle atrophy, microcytic anemia, arthralgia, arthritis, basal ganglia calcification, failure to thrive, nodular episcleritis, conjunctivitis, keratitis	Severe cutaneous vasculopathy, interstitial lung disease	Vasculopathy/vasculitis early lacunar strokes, hepatosplenomegaly, mild immunodeficiency, cutaneous and systemic vasculitis, mild immunodeficiency
Skin manifestations	Maculopapular nodular rash	Migratory erythematous rash	Sweet's syndrome, pustulosis	Variable	Violaceous eyelids, annular plaques, early-onset pemio-like lesions, panniculitis- induced lipodystrophy	Cutaneous vasculopathy	Cutaneous vasculitis, livedo reticularis
Amyloidosis	Not noted	25%	Not noted	Not noted	Not noted	Not noted	Not noted
Inheritance	Autosomal dominant and de novo NOD2/CARD15 encoding NOD2	Autosomal dominant TNFFSF1A-encoding p55 TNF receptor	Autosomal recessive	Unknown	Autosomal recessive, PSMB-8 gene proteasome subunit- type 8	Autosomal dominant and de novo TMEM173	Autosomal recessive, CECR1
Treatment	Steroids, anti-TNF therapy	Steroids and possibly anti-TNF therapy, anti-IL-1 therapy	Steroids, NSAIDs, anti-IL-1 therapy	Tonsillectomy, steroids, cimetidine	Partial response to steroids, anti-TNF therapy, anti-IL-1 therapy, anti-IL-6 therapy	Interferon inhibitors/ JAK kinase inhibitors (e.g. tofacitinib)	Steroids

TRAPS – TNF receptor-associated periodic fever syndrome, PFAPA – periodic fevers, aphthous stomatitis, pharyngitis and adenitis, PRAAS – proteasome associated autoinflammatory syndromes, CANDLE – chronic atypical neutrophilic dermatosis with lipodystrophy and elevated temperature, JMP – joint contractures, muscle atrophy, microcytic anemia and panniculitis-induced lipodystrophy, JASL – Japanese autoinflammatory syndrome with lipodystrophy, SAVI – STING-associated vasculopathy with onset in infancy, DADA-2 – deficiency of ADA2.

of these diseases have been registered,<sup>14</sup> including many variants of unclear significance.

In recent years, based on the inheritance pattern, age of onset, duration, frequency and associated features of the attacks and ethnicity, *decision-making trees* have been proposed in the evaluation of patients with periodic inflammatory episodes,<sup>15,16</sup> but these algorithms are most applicable in areas of higher prevalence.

## Pathogenesis

An exaggerated inflammatory response appears to occur, due to increased sensitivity to normal or insignificant stimuli, or due to the inability of the immune system to dampen normal responses in an efficient and timely manner. Most of the mutated proteins in these disorders are members of the death-domain fold (DDF) family, which are involved in apoptosis, NF- $\kappa$ B activation and proinflammatory cytokine production. More recently, another mechanism was found: the role of protein misfolding in increasing cellular stress, causing an increase in reactive oxygen species, which in turn triggers an exaggerated inflammatory response with only minimal secondary stimuli such as lipopolysaccharide. In addition, defects in autophagy and proteasome function are other possible pathways causing autoinflammation.<sup>17</sup> There have been conflicting results of the studies; these may be related to differences in experimental models. It is possible that these proteins assume different roles under different situations and that the dosage of gene and other modifier genes have effects on the immune/inflammatory pathways contributing to the variable presentations of the diseases.<sup>5,17–20</sup>

## Familial Mediterranean Fever (FMF)

FMF was the first described autoinflammatory disease: in 1908 by Janeway and Rosenthal in a Jewish girl, and in 1945 by Siegal. The initial spread of FMF can be traced back to Mesopotamia 2,500 years ago. It is an autosomal recessive condition reported worldwide, but most patients have ancestry in the Mediterranean basin, particularly in the Middle East, where the prevalence is 1:250 to 1:1,000,<sup>21</sup> with a carrier frequency as high as 1 in 3 to 5, suggesting survival via an enhanced innate immune response. Carriers of the FMF gene have a heightened inflammatory response, supporting this hypothesis.<sup>22,23</sup> After mapping of the FMF susceptibility locus to chromosome 16p in 1992,<sup>24</sup> the mutated gene, named *MEFV* (MEditerranean FeVer) was discovered by two independent groups using positional cloning in 1997.<sup>25,26</sup> The deduced protein *pyrin* (the Greek for 'fever')/*Marenostrin* (the Latin 'Mare Nostrum' for 'our sea') is 781 amino acids long and is primarily expressed in the cytoplasm of neutrophils but is also found in other cells. Almost all mutations are missense mutations: via its N-terminal death domain (pyrin domain-PYD), pyrin interacts with the pyrin domain of the adapter protein ASC (apoptosis-associated speck-like protein) to assemble and activate inflammatory complexes. These proteins have been found to play a role in controlling IL-1 $\beta$  production by regulating caspase-1. The exact physiologic role and underlying mechanisms of mutated pyrin are not well understood. Pyrin mutations result in gain of function but the expression of the disease depends on how much mutated protein is produced.<sup>17</sup>

Mutations in position 694 usually cause a more severe phenotype, especially M694V. Low penetrance mutations, such as

E148Q, are also described. The allele frequency of E148Q is 10% to 20% in Asians and 1% to 2% in Caucasians.<sup>27,28</sup>

FMF episodes may be triggered by physical or emotional stress, infections, exercise, menstruation and diet. An attack may be preceded by malaise, irritability and decreased appetite. Major features are fever and abdominal pain due to serositis, mostly peritonitis (95%), recurrent attacks of which may cause adhesions. Pleuritis, which is usually unilateral, is seen in about 40% of patients, while pericarditis is rare in FMF. Orchitis occurs in about 5% and is more common in children. Arthritis/arthralgia affects primarily the lower extremities and is transient, resolving without any sequelae, though some patients may develop chronic destructive arthritis. Exercise-induced myalgia may occur during an episode. The erysipelas-like rash, commonly seen around the ankles, is a relatively unique feature of FMF and occurs in about 20% to 30% of patients. Prolonged, severe muscle pain affecting lower extremities and abdominal muscles, known as protracted febrile myalgia, may rarely occur and is responsive to steroid therapy. Occasionally, there is an accompanying vasculitic rash.<sup>29,30</sup> Laboratory investigation reveals leukocytosis and elevated inflammatory markers. SAA and S100A2 levels<sup>4,31,32</sup> may be used to follow disease activity.

Diagnosis is still primarily clinical because about 25% of the patients have a negative genetic analysis for *MEFV* mutation. Furthermore, a significant number of patients with homozygosity never develop clinical features, while about 30% to 40% of the patients with FMF are heterozygotes. This variability is thought to be due to the dose effect of the mutated protein. Clinical criteria for diagnosis in adults were proposed by Livneh in 1997<sup>33</sup> and guidelines for diagnosis in children have been published.<sup>34</sup> Both sets of criteria are highly specific and sensitive in areas of high prevalence, but not in less prevalent areas. Certain vasculitides such as Henoch-Schönlein purpura (HSP) and polyarteritis nodosa (PAN) have increased frequency in FMF patients.<sup>29</sup> Behçet's disease is also more common in carriers and FMF patients.<sup>35</sup>

Colchicine is the mainstay of the treatment of FMF<sup>28</sup> and eliminates or substantially decreases symptoms in about 95% of patients. More importantly, regular use of colchicine prevents the development of amyloidosis, the major contributor to morbidity and mortality in these patients. Before colchicine use, up to 75% of patients would develop amyloidosis after the age of 40 years. Risk factors for amyloidosis include M694V mutation, male gender, SAA  $\alpha/\alpha$  genotype and family history of amyloidosis.<sup>30,36</sup> Environmental factors also play a crucial role in the development of amyloidosis.<sup>22,37</sup>

To date, the mechanism of action of colchicine in FMF is not well understood. Colchicine accumulates primarily in neutrophils and is postulated to affect neutrophil adhesion and mobility by binding to the cytoskeleton of the cells<sup>30</sup> and preventing microtubule elongation. It is generally well tolerated with minimal side-effects,<sup>38</sup> diarrhea being the most common (10–20%).<sup>39</sup> Acute toxicity from an overdose can be very serious since it has a narrow therapeutic window. Studies have suggested that it is safe to use during pregnancy and lactation and does not affect fertility.<sup>40</sup> Colchicine is used as a preventative therapy. Intermittent use or increasing the dose during attacks has no role in management of FMF. Colchicine resistance is rare (< 5%), therefore an alternative diagnosis or noncompliance should be considered in nonresponsive patients. IL-1-blocking drugs (anakinra, rilonacept, canakinumab) are the drugs of choice in colchicine resistant or intolerant patients.<sup>40</sup>

## TNF Receptor-Associated Periodic Fever Syndrome (TRAPS)

TRAPS, an autosomal dominant AD, was formerly known as ‘Hibernian fever’. It was first described in Ireland in 1982<sup>41</sup> and is most common in Irish and Scottish populations but is now known to occur worldwide (<http://fmf.igh.cnrs.fr/ISSAID/infervers/>).

The association of this syndrome with mutations in the *TNFRSF1A* gene on chromosome 12p13 was discovered in 1999.<sup>42</sup> This gene encodes the TNF receptor type 1 (also known as p55TNFR). Binding of TNF- $\alpha$  to its receptor initiates the intracellular activation cascade through the death domain, leading to the activation of both NF- $\kappa$ B and apoptosis pathways.

The pathogenesis of TRAPS is still not clear and several mechanisms have been proposed.<sup>5,42–44</sup> To date, more than 130 mutations have been described (<http://fmf.igh.cnrs.fr/ISSAID/infervers/>). Among these mutations R92Q is the most common variant in Caucasians and P46L in African-Americans. The R92Q substitution has been found in chromosomes of 1% to 35% of the general population.<sup>45,46</sup> These mutations may have reduced penetrance, leading to atypical presentations of TRAPS.<sup>18</sup>

Fevers in TRAPS generally last longer than those in other forms of periodic fever syndromes, ranging from 1 to 3 weeks. Attacks occur at irregular intervals from once to seven times a year. In a subset of patients, the symptoms are present continuously.<sup>47</sup> The age of onset is about 3 years (ranging from 1 to 63 years). Common features of TRAPS include severe abdominal pain (92%) due to serositis with risk of adhesions, painful centrifugally migrating myalgia (due to monocytic fasciitis) that can be associated with an overlying painful erythematous rash, ocular inflammation with conjunctivitis, uveitis, unilateral periorbital edema and arthralgia (less commonly arthritis) primarily affecting large joints. Other findings may include chest pain due to pleuritis, pericarditis, myocarditis and scrotal swelling. Similar to other AD, elevated inflammatory markers are found. In addition, some patients have low soluble TNF receptor levels between episodes. The risk of amyloidosis is greatest in patients with mutations involving cysteine substitutions, reported to be as high as 24% without treatment.<sup>12,47</sup>

Nonsteroidal antiinflammatory drugs (NSAIDs), steroids and colchicine are used with some success in this condition.<sup>48</sup> Etanercept, a dimeric fusion protein consisting of the p75 portion of TNFR linked to Fc portion of IgG1, decreases the severity of the attacks in the majority of patients but the effect seems to wane over time in some patients. Furthermore, the efficacy of this therapy may wane over time. Interestingly, infliximab and adalimumab, which are monoclonal antibodies against TNF- $\alpha$ , paradoxically trigger exacerbations of febrile episodes in some patients. Etanercept nonresponders may respond to the IL-1 receptor antagonists (anakinra).<sup>13,48</sup>

## Mevalonate Kinase Deficiency (MKD)/Hyper IgD Syndrome (HIDS)

MKD, formerly known as HIDS because of the initial observation of elevated IgD levels in patients, was first described in 1984 in 6 Dutch patients.<sup>49</sup> An unexpected finding was that the

gene causing MKD was found to encode mevalonate kinase, an enzyme in the cholesterol biosynthesis pathway.<sup>50,51</sup> The enzyme was already known to be implicated in mevalonic aciduria (MA), which is a metabolic disorder that presents in infancy with devastating neurologic abnormalities (mental retardation, cerebellar ataxia, cataracts, hypotonia, dysmorphic features) and eventually leads to early death. MA shares many of the features of HIDS, hence the name was changed to MKD. HIDS and MA are a phenotypic continuum of mevalonate kinase deficiency, from mild to severe disease.<sup>52</sup>

Heightened inflammatory response caused by abnormal functioning of an enzyme in the cholesterol biosynthesis pathway was ultimately shown to be connected to the IL-1 $\beta$  pathway.<sup>50,53</sup>

The most common mutation in MKD is at position V377I, a founder effect from a common ancestor. High frequency of this mutation in Northern Europe is thought to be a selective advantage related to higher consumption of saturated fat. Urine mevalonic acid level increases during the episodes in HIDS,<sup>54</sup> while it is persistently high in MA. Enzyme activity is 1–10% in HIDS but < 1% in MA. The activity of the mutated enzyme decreases even further with fevers. Mevalonic acid accumulates and end products, which are important in isoprenylation of proteins, decrease. The shortage of some of these end products, especially geranylated proteins, is involved in increased IL-1 $\beta$  production. Not every patient with MKD has elevated IgD levels, especially children.<sup>55</sup> Elevated IgD levels have also been described in infections such as tuberculosis and other inflammatory conditions, including other periodic fever syndromes. Polyclonal IgA elevation may also be seen in HIDS.

Onset is often in infancy (90%) and is characterized by fevers recurring every 4 to 8 weeks, accompanied by painful cervical lymphadenopathy (90%), abdominal pain and vomiting (70%), an often maculopapular, occasionally urticarial, purpuric and erythema nodosum type skin rash (60%), arthralgia/myalgia (80%), aphthous and/or genital ulcers (50%) and hepatosplenomegaly (30%). Chills and sweating are also common. Arthritis affecting large joints and pleuritis are less common.<sup>55</sup> Immunizations and other stressors such as trauma or infections usually trigger attacks. Features of MKD resemble those of periodic fever, aphthous stomatitis, pharyngitis and cervical adenitis (PFAPA). In the majority of the patients flare frequency decreases in adulthood. Amyloidosis is rare in MKD but not unheard of. Mild immunodeficiency features have been described in some patients.<sup>6</sup>

Effective treatment for HIDS is not available. Steroids, etanercept and colchicine are beneficial in a small group of patients. Lately anakinra has shown some promise. Simvastatin, an HMG-CoA reductase inhibitor, may help in some patients with HIDS but it may exacerbate the condition in some patients with MA. There are also anecdotal reports of benefit from the leukotriene inhibitor, montelukast.

## Cryopyrin-Associated Periodic Syndromes (CAPS)

CAPS constitute a spectrum of conditions that share a similar genotype, with mutations in the gene encoding for cryopyrin (also known as *NLRP3*, *NALP3* and *PYPAF1*). Cryopyrin belongs to the NLR (nucleotide-binding domain and



leucine-rich repeat) protein family<sup>56</sup> and is found primarily in activated T cells, monocytes, neutrophils and chondrocytes. These conditions are autosomal dominant, but *de novo* mutations may occur. Due to the association with cold exposure and development of fever, the protein was named as ‘cryopyrin’ and familial cold-induced urticaria was renamed as ‘familial cold autoinflammatory syndrome’.

From *most to least* severe, the CAPS are neonatal onset multisystem inflammatory disease (NOMID), Muckle-Wells syndrome (MWS) and FCAS; however, CAPS represent a spectrum of pathology and there may be a clinical overlap among these conditions.

The first CAPS to be described was FCAS, as early as 1940.<sup>57</sup> MWS was first described in 1962 with a triad of urticaria, deafness and amyloidosis in nine members of a family over five generations.<sup>58</sup> NOMID was probably first reported in the literature in 1975: two siblings, born to nonconsanguineous parents, were described as having a Still’s disease-like rash, deforming arthropathy, mental retardation and uveitis.<sup>59</sup>

Clinical similarities between these three phenotypically different entities led to the discovery that the underlying mutations were homologous. The mutations for CAPS were first reported in 1996 and later confirmed in 2000 and 2001.<sup>60</sup>

Cryopyrin contains three domains: an N-terminal pyrin domain (PYD), a nucleotide-binding oligomerization domain (NOD or NLRP3) and a leucine-rich repeat (LRR) region. Cryopyrin is an intracellular pattern recognition receptor and recognizes pathogen-associated molecular patterns and danger-associated molecular patterns (PAMPS and DAMPS) via LRR. Cryopyrin is integral in the activation of the cryopyrin inflammasome: it interacts with ASC (apoptosis-associated speck-like protein) and CARDINAL to form the activated complex with two procaspase molecules, generating active caspase-1 and leading to IL-1 $\beta$  and IL-18 activation. Studies suggest that the *CIAS1* mutation is a gain-of-function mutation, likely causing the loss of autoinhibition or the regulatory step in NLRP3 activation, allowing for the autoassembly and activation of the inflammasome without typical stimuli (PAMPS and DAMPS). These mutations, found on chromosome 1q, appear to lead to increased caspase-1 activation and thus increased IL-1 $\beta$  secretion. No typical mutation is found in up to half of patients with CAPS, but a recent analysis of NOMID patients found that nearly two thirds of mutation-negative patients had somatic mosaicism mutations in 4.2% to 35.8% of the cells.<sup>61</sup>

All three phenotypes of CAPS are associated with an urticaria-like skin rash that is characterized by interstitial and perivascular infiltrates primarily composed of neutrophils.<sup>62</sup> This rash forms erythematous flat wheals, often symmetric and sparing the face, typically nonpruritic rather burning or painful, and generally lasting for more than 24 hours.<sup>63</sup>

FCAS patients typically present in early infancy. Symptoms usually occur several hours following exposure to generalized cold. The urticarial rash, sometimes associated with swelling, is the most common feature. Arthralgia, myalgia, fever, conjunctivitis, fatigue, headache and nausea are common features. Attacks typically last 24 hours or less.

MWS patients typically present during adolescence with attacks lasting 24 to 48 hours at irregular intervals every few weeks. Arthralgia and myalgia accompany the fevers and rash during typical attacks. Progressive sensorineural hearing loss is common (75%), and different *NLRP3* mutations may predict the trajectory of hearing loss, with the T348M mutation at

highest risk in one report.<sup>64</sup> About a third of patients develop secondary amyloidosis with nephropathy.

NOMID, also known as chronic infantile neurologic cutaneous and articular syndrome (CINCA), typically presents in early infancy and is associated with significant neurologic symptoms including chronic meningitis, increased intracranial pressure, developmental delay, seizures, papilledema, papillitis, uveitis, optic atrophy, blindness and sensorineural hearing loss, as well as daily fevers. These patients also have major bony abnormalities with dysmorphic features including frontal bossing, severe arthropathy and joint deformity. The arthropathy typically is symmetric, affecting large joints, and is caused by abnormal endochondral formation and bony overgrowth. Without treatment, patients suffer significant morbidity, and early death before adulthood occurs in 20% of affected individuals.

NSAIDs are typically inadequate to treat these conditions completely. Steroids may have some limited benefit. IL-1 Trap, or rilonacept, a fully human dimeric fusion protein, binds soluble IL-1 and prevents its interaction with cell surface receptors. It was approved by the US Federal Drug Administration (FDA) in 2008 for CAPS under orphan drug designation. Canakinumab, a human anti IL-1 $\beta$  monoclonal antibody with no cross-reactivity to other members of the IL-1 family, is effective in patients with CAPS<sup>65</sup> and was approved by the FDA for this indication in June 2009. Anakinra, an iIL-1 receptor antagonist, competitively inhibits the binding of IL-1 $\alpha$  and IL-1 $\beta$  to the IL-1 receptor, was approved for NOMID in 2013 for children under orphan drug designation, and is efficacious in patients with CAPS. Anti-IL-1 therapy is not only effective for the acute symptoms, such as fevers, rash, arthritis and headaches, but also appears to halt the progression of arthropathy and central nervous system decline including developmental delay and vision and hearing loss.

## NLRP12-Associated Autoinflammatory Disorder

NLRP12AD, also known as Guadeloupe-type fever syndrome, is a rare autosomal dominant disease with variable penetrance that results from mutations in the NLRP12 protein found on 19q13.42.<sup>66</sup> This protein is an intracellular sensor of the innate immune system and belongs to the Nod-like receptor (NLR) family, which regulates inflammatory processes through inhibition of NF- $\kappa$ B and IL-1 $\beta$  signaling and is distinct from the NLRP3 inflammasome. The exact role of NLRP12 remains unknown but there is thought to be a loss-of-function mutation that allows for the up-regulation of NF- $\kappa$ B and IL-1 $\beta$ . The pathogenesis of this condition is not yet fully understood.

The clinical presentation of this condition overlaps with cryopyrin-associated periodic syndromes (CAPS); prior to the discovery of this novel mutation in 2008, patients were categorized as ‘mutation-negative’ CAPS. As in MWS and FCAS, symptoms are typically induced by cold exposure and manifest with recurrent fevers lasting 5 to 10 days with associated rash, headache, lymphadenopathy, aphthous ulcers, abdominal pain and sometimes sensorineural hearing loss. The clinical phenotypes can be variable and may improve in adulthood. Patients typically do not respond to IL-1 blockade. Treatments used for this condition include avoidance of cold, antihistamines, NSAIDs and steroids.

## Deficiency of Interleukin-1-Receptor Antagonist (DIRA)

DIRA is a very rare condition that was first reported in 2009.<sup>67,68</sup> These patients present in early infancy mimicking sepsis with multifocal osteomyelitis, periostitis, pustular skin lesions, hepatosplenomegaly, thrombosis and multi-organ failure. DIRA shares many clinical features with NOMID but fever is generally absent or low grade. Osteolytic lesions, sclerosis and epiphyseal enlargement are seen on x-rays and acute-phase reactants are persistently elevated. Rare features are interstitial lung disease, CNS vasculitis and atlanto-axial subluxation.<sup>2</sup>

DIRA is autosomal recessive and is associated with deletion or truncating mutations in a 175-kb sequence of chromosome 2q13 that encompasses five IL-1 family members as well as the IL-1 receptor antagonist (*ILRN*). The *ILRN* mutation appears to result in truncated proteins that are not secreted, leading to cells being hyperresponsive to IL-1 $\alpha$  and IL-1 $\beta$  stimulation. Patients respond rapidly and dramatically to anti-IL-1 therapy, with full resolution of symptoms in the majority of patients.<sup>67,68</sup>

## Blau Syndrome/Pediatric Granulomatous Arthritis

Blau syndrome is a systemic inflammatory condition which was first described in 1985: 11 family members over four generations had granulomatous disease of the skin, eyes and joints.<sup>69</sup> Early-onset sarcoidosis, considered to be the sporadic form, is caused by the same gain-of-function mutation.<sup>70</sup> Blau syndrome typically presents at less than 5 years of age and is characterized by a maculopapular rash, noncaseating granulomatous arthritis, uveitis and lymphadenopathy; fever may be absent. Noncaseating epithelioid granulomas are found on tissue biopsies. It is distinguished from the autoimmune condition, sarcoidosis, based on its early age of onset and lack of lung and hilar lymph node involvement.

Blau syndrome is an autosomal dominant condition, involving chromosome 16q12, and over 120 mutations have been described to date (<http://fmf.igh.cnrs.fr/ISSAID/infevers/>). The gene encodes NOD2 (also known as CARD15), which is expressed primarily in myeloid cells, Paneth cells of the small intestine and activated intestinal epithelial cells, and is a member of the NLR protein family.

Similar to cryopyrin, NOD2 appears to function as a cytoplasmic pattern recognition receptor; it recognizes PAMPS and is integral in NF- $\kappa$ B activation. Bacterial cell wall peptidoglycans such as muramyl dipeptide stimulate the NOD2 inflammasome.<sup>71</sup> Mutations appear to be gain of function due to loss of autoinhibition. However, patients do not appear to have excess IL-1 $\beta$  activity, so the underlying mechanism for this condition remains under study.<sup>48,72</sup>

In Crohn's disease (CD), another inflammatory granulomatous condition, mutations have been reported in the LRR region of *NOD2*. These mutations may theoretically lead to diminished intracellular sensing of bacteria, thereby leading to diminished activity of the NOD2 inflammasome (loss of function). The exact role of these mutations in CD remains under investigation.

Anecdotal evidence supports the use of steroids, immunomodulation with TNF- $\alpha$  inhibitors and possibly other

immunomodulatory therapies, such as thalidomide, methotrexate and anti-IL-1 therapy, in the treatment of Blau syndrome.

## Majeed Syndrome

Majeed syndrome is a very rare pyogenic autoinflammatory disease of most commonly Arabic populations, first described in 1989 in a consanguineous Kuwaiti family, where three children presented with congenital dyserythropoietic anemia, chronic recurrent multifocal osteomyelitis and neutrophilic dermatosis.<sup>73</sup>

Patients typically present at less than 2 years of age with chronic recurrent episodes of commonly metaphyseal sterile osteomyelitis, and fever, typically lasting several days, with associated destructive arthritis and deformities. Attacks may occur every 2 to 4 weeks, but continuous symptoms have also been reported. Pustular rashes, Sweet's syndrome, hepatosplenomegaly and cholestatic jaundice are also reported. Patients may have transient neutropenia in infancy. Chronic dyserythropoietic anemia may require regular transfusions.

Majeed syndrome is an autosomal recessive disorder involving the *LPIN2* gene with loss-of-function mutations on chromosome 18p.<sup>74</sup> The role of *LPIN2* in Majeed syndrome is not clear but it may play a role in cellular response to oxidative stress.

Systemic corticosteroids and NSAIDs appear to provide clinical improvement in patients. Data are limited with regard to disease-modifying antirheumatic agents or biologics although recently anti-IL-1 therapies have shown good results.<sup>75</sup>

## Pyogenic Sterile Arthritis, Pyoderma Gangrenosum and Acne (PAPA)

PAPA was first recognized in 1975 and described in 1997<sup>76</sup> with the clinical features in its name. A very destructive arthritis is typically present, associated with pyoderma gangrenosum skin lesions and sterile muscle inflammation. Pathergy and ulcerations following pustule formation after vaccinations or trauma are common features. Rosacea and psoriasis may be seen in some patients. Arthritis tends to start early in life, and pyoderma gangrenosum and acne around puberty. About 20% to 40% develop sulfonamide-induced pancytopenia,<sup>77</sup> the cause of which is not clear. Leukocytosis and elevated acute-phase reactants are common.

PAPA is an autosomal dominant condition (chromosome 15q24–q25.1) and is associated with mutations with variable penetrance in *PSTPIP1*, which is highly expressed in neutrophils and T cells. The genetic association was described in 2002.<sup>78</sup> *PSTPIP1* interacts with pyrin,<sup>79</sup> mutations lead to hyperphosphorylation, which appears to increase the interaction of *PSTPIP1* with pyrin, reducing pyrin's regulatory effect on the NALP3/cryopyrin inflammasome (Figure 14-1). *PSTPIP1* is also known as CD2-binding protein (CDBP1) and interacts with CD2, Wiskott-Aldrich syndrome protein (WASP) and FasL, implying a role in the adaptive immune system related to antigen recognition.

Anecdotal evidence suggests that steroids, anti-TNF therapy and anti-IL-1 therapy may be of benefit, especially for the arthritis, though anti-IL-1 $\beta$  therapy does not appear as effective

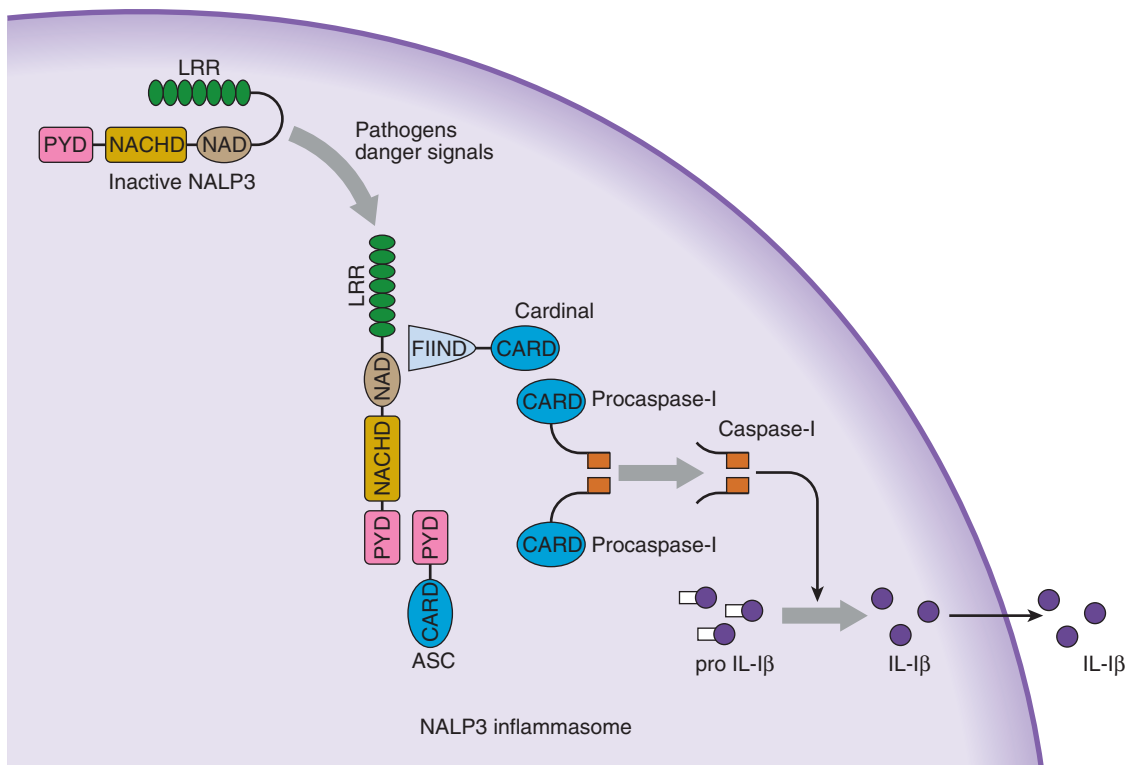

**Figure 14-1** The NALP3/cryopyrin inflammasome. NALP3 is usually found in an inactive state and is activated by ‘danger signals’ such as peptidoglycans, ATP, uric acid crystals, bacterial RNA, etc., which leads to its unfolding and association with the remainder of the NALP3 inflammasome components FIIND (domain with function to find), CARDINAL, ASC and procaspase 1, via association between pyrin (PYD) and CARD domains. The NALP3 inflammasome induces the cleavage of procaspase-1 to caspase, leading to the activation of IL-1 $\beta$  from pro IL-1 $\beta$ .

as in CAPS, suggesting that the mutations implicated in PAPA have additional effects beyond IL-1 overexpression.<sup>80</sup>

SAPHO (synovitis, acne, pustulosis, hyperostosis, osteitis), CNO (chronic nonbacterial osteomyelitis) and PASH (pyoderma gangrenosum, acne, suppurative hidradenitis) should be considered in the differential diagnosis of PAPA.

## Periodic Fevers, Aphthous Stomatitis, Pharyngitis and Adenitis (PFAPA)

PFAPA is the most common periodic fever/AD; its features are listed in its name. Marshall et al first described it in 1987,<sup>81</sup> followed by the publication of several other series.<sup>82–84</sup> Age of onset younger than 5 years is in the original diagnostic criteria but PFAPA has been described in older children and even in adults.<sup>85</sup> It has a male predominance and no known long-term sequelae. Strikingly regular intervals between episodes, usually every 4 weeks (3–8 weeks) as well as normal growth and development are signature features of PFAPA. Episodes usually last 4 to 6 days and frequently start and end abruptly. Constitutional symptoms such as malaise, chills and headache may also be present. Less commonly, gastrointestinal symptoms, rash and arthralgia may occur. Oral ulcers usually are shallow and lymphadenopathy is often bilateral and tender.<sup>85</sup> Leukocytosis and mild elevation of the inflammatory markers are seen in most patients. Recent studies show monocytosis and decreased lymphocyte and eosinophil counts during episodes.<sup>86,87</sup>

Almost all patients with PFAPA dramatically respond to one or two doses of corticosteroids (0.5–2 mg/kg prednisone or prednisolone), especially when given prior to the onset of fever.<sup>82–84</sup> Corticosteroid therapy does not prevent subsequent episodes, but patients continue to respond on subsequent cycles. In a subgroup of patients, the frequency of episodes increases with corticosteroid therapy. Treatment may include tonsillectomy with or without adenoidectomy<sup>88–93</sup> and may induce remission in patients. Efficacy of cimetidine in PFAPA is modest (29%).<sup>94</sup>

The etiology of PFAPA is unknown. Studies in recent years suggest an aberrant immune response involving possibly both innate and adaptive immunity.<sup>88,95</sup> Levels of IL-1 $\beta$ , IL-6, IP-10 (CXCL10), CXCL9 and G-CSF increase during episodes. Furthermore, the level of CXCL10 and G-CSF increase during episodes seems to differentiate PFAPA from other periodic fever syndromes.<sup>86</sup> These cytokines and chemokines are related to T cell activation and recruitment to the tissues, suggesting the role of adaptive immunity in the pathogenesis.<sup>87,89</sup> Tonsillar tissue shows lymphoid hyperplasia and chronic inflammation.<sup>89</sup>

Although the genetic basis of PFAPA has yet to be identified, familial cases have been described in recent years.<sup>95</sup> Some of the low penetrance mutations or variants of other monogenic periodic fever syndromes such as NOD2, MEFV and TNFRSF1A have been found in PFAPA patients.<sup>96</sup> In one recent study PFAPA patients carrying *MEFV* mutations had milder PFAPA episodes.<sup>97</sup>

PFAPA typically resolves by adolescence. Long-term follow-up of patients in one study showed resolution in 50 out of 59 patients by age 6.3 and by the age of 18 in the rest.<sup>98</sup>

## Recently Discovered Autoinflammatory Disorders

### DEFICIENCY OF IL-36 RECEPTOR ANTAGONIST (DITRA)

In 2011, predominantly homozygous mutations in the IL-36 receptor antagonist (IL36RN) gene were described, initially in 16 Tunisian family members with generalized pustular psoriasis (GPP)<sup>99</sup> and later in unrelated English patients. The phenotype includes sudden onset episodes of pustular rash accompanied by high grade fevers, and malaise, primarily triggered by infections but also by other stressors such as menstruation, pregnancy and withdrawal of retinoid therapy. Elevated inflammatory markers and leukocytosis are common. Secondary skin infections and sepsis have also been reported.

Following the discovery of *IL-36RN* mutations in patients with GPP, namely DITRA, mutations in this gene were also found in other pustular disorders<sup>100</sup> such as palmoplantar pustulosis, acrodermatitis continua of Hallopeau (ACH) and acute generalized exanthematous pustulosis (AGEP). Autosomal dominant gain-of-function mutations in *CARD14* have also been found in severe GPP and plaque psoriasis,<sup>101</sup> as well as pityriasis rubra pilaris.<sup>102</sup>

### DEFICIENCY OF ADA2 (DADA2)

In 2014, two independent groups found autosomal recessively inherited loss-of-function mutations in the same gene, *CECRI* (cat-eye syndrome region, candidate1), encoding ADA2 (adenosine deaminase 2). These mutations cause two different, yet related phenotypes whose main feature is vasculopathy/vasculitis. One of the phenotypes includes intermittent fevers, early-onset lacunar strokes, hepatosplenomegaly and systemic vasculopathy with mild immunodeficiency.<sup>103</sup> The second phenotype is characterized by cutaneous and systemic polyarteritis nodosa with variable penetration.<sup>104</sup> ADA2 is a growth factor and also has catalytic activity.

### PROTEOSOME ASSOCIATED AUTOINFLAMMATORY SYNDROMES (PRAAS)

Chronic atypical neutrophilic dermatosis with lipodystrophy and elevated temperature (CANDLE), joint contractures, muscle atrophy, microcytic anemia and panniculitis-induced lipodystrophy (JMP) syndrome, Nakajo-Nishimura syndrome and Japanese autoinflammatory syndrome with lipodystrophy (JASL; described first in 1939 in Japan) are rare related conditions<sup>105</sup> that were found to be the result of the same gene defect in 2010.<sup>106–108</sup> These autosomal recessive conditions are caused by mutations in the proteasome subunit beta-type 8 (*PSMB8*) gene, which encodes the  $\beta 5i$  subunit of the proteasome. Immunoproteasomes are multiunit proteases which are evolutionarily conserved and key in nonlysosomal protein degradation in nucleated cells following activation. Functional assays demonstrate high levels of interferon gamma-inducible protein (IP-10), suggesting increased interferon responses in CANDLE syndrome patients, which is a novel mechanism in the pathogenesis of AD.<sup>109</sup>

Patients with PRAAS are reported to present in a similar fashion, typically in early infancy. They have recurrent fevers, rash manifested by annular plaques, early-onset pernio-like

lesions, dactylitis, arthritis/arthritis and elevated inflammatory markers. Other clinical features reported include basal ganglia calcification, hepatomegaly, splenomegaly, muscle atrophy, lymphadenopathy, failure to thrive and violaceous eyelids. Joint contractures and lipodystrophy may occur later, and there is early mortality related to multi-organ failure.

Treatment for PRAAS is limited but patients show partial response to high-dose steroids and a varied but limited response to biologic agents including anti-TNF, anti-IL-1 and IL-6 therapies.

### STING ASSOCIATED VASCULOPATHY WITH ONSET IN INFANCY (SAVI)

In 2014, de novo mutations in the gene *TMEM173* encoding STING (stimulator of interferon genes) protein were discovered in patients with the phenotype of severe cutaneous vasculopathy, starting in infancy with systemic inflammation. Some patients have interstitial lung disease (ILD) as well.<sup>110</sup> STAT1 seems to be constitutively upregulated in these patients, suggesting mutations causing gain of function. Since interferon pathways are affected, SAVI is considered among the interferonopathies such as Aicardi-Goutieres syndrome.

## Others

Some of the mutations/variants seen in monogenic AD have been shown to be more common in other well-known immune conditions (e.g. *MEFV* mutations in HSP and PAN). They have also been considered as modifier genes in newly described entities such as *MEFV* polymorphisms and *TNFRSF1A* mutations in IMAM (inflammatory myopathy with abundant macrophages).<sup>111</sup> In other cases an autoinflammatory arm has been added to already known related syndromes such as *SCLC29A3* gene mutation related syndromes which include H syndrome (inherited systemic histiocytosis, referring to the clinical findings of hyperpigmentation, hypertrichosis, hepatosplenomegaly, heart anomalies, hearing loss, hypogonadism, low height and hyperglycemia), pigmented hypertrichosis with type 1 diabetes, Faisalabad histiocytosis and sinus histiocytosis with massive lymphadenopathy.<sup>112</sup> Finally, very recently, novel mutations in the PAPA syndrome gene, *PSTPIP1*, have been shown to also cause hyperzincemia/hypercalprotectinemia, the phenotype of which includes hepatosplenomegaly, arthritis, anemia, cutaneous inflammation and failure to thrive.<sup>113</sup> *MVK* gene mutations were found in disseminated superficial porokeratosis (DSAP),<sup>114</sup> retinitis pigmentosa and early-onset inflammatory bowel disease.<sup>115</sup> Interestingly, in retinitis pigmentosa the enzyme activity is as low as in mevalonic aciduria, yet patients do not have the severe phenotype of mevalonic aciduria patients.<sup>116</sup>

## Conclusions

Discoveries in relatively rare conditions that are well known clinically, such as FME, can unveil the mechanisms of common, yet complicated homeostatic pathways of biologic systems, such as production of inflammation against non-self and danger signals. The term 'autoinflammatory disorders' was initially coined to describe the monogenic periodic fever syndromes when it was first proposed over 15 years ago. Today, it has become an encompassing term to include diverse conditions that involve not only the disorders of other aspects of the innate



immune system (hereditary angioedema [HAE], atypical hemolytic uremic syndrome [aHUS]) but also polygenic (Crohn's disease, Behçet's disease, systemic onset JIA), metabolic (gout, pseudogout) and storage (Gaucher's) disorders. The significant role that innate immunity plays is becoming clearer in conditions previously thought to be solely related to abnormalities in the adaptive immune system such as contact hypersensitivity and autoimmune conditions (rheumatoid arthritis and systemic lupus erythematosus). Finally, significant progress has also been achieved in understanding how environmental factors play a role in variable presentations of a particular condition, such as activation of the NLRP3 inflammasome in macrophagic myofasciitis, the result of immune activation caused by injection of aluminum hydroxide adjuvant vaccines and hence renamed as ASIA (autoimmune/inflammatory syndrome induced by adjuvants).<sup>117</sup> Similarly, monosodium urate crystals, silica and asbestos activate inflammasomes. The genetic bases of many AD are found to be related to mutations in genes encoding proteins that have roles in inflammation, cytokine

signaling and processing and apoptosis. Our knowledge of the diverse roles of the innate immune system and its intimate cross-talk with the adaptive immune system has expanded exponentially.

Advances in understanding of inflammation with the discovery of mutations in genes causing many AD have led to the discovery of additional related conditions at a rapid pace since the last edition of this book. In many fields of medicine it has become clear that well-defined disease entities are usually the tip of the iceberg and that the majority of the patients are scattered throughout a spectrum. The important role of techniques in molecular biology, such as next generation sequencing, is anticipated. In short, the more we discover, the more the plot thickens, opening up new avenues of exciting research and application to clinical practice.

The complete reference list can be found on the companion Expert Consult website at <http://www.expertconsult.inkling.com>.

## KEY REFERENCES

2. De Jesus AA, Goldbach-Mansky R. Monogenic autoinflammatory diseases: concept and clinical manifestations. *Clin Immunol* 2013;147:155–74.
13. Bodar EJ, Drenth JPH, Van Der Meer JWM, Simon A. Dysregulation of innate immunity: hereditary periodic fever syndromes. *Br J Haematol* 2009;144:279–302.
17. Savic S, Dickie LJ, Wittmann M, McDermott MF. Autoinflammatory syndromes and cellular responses to stress: pathophysiology, diagnosis and new treatment perspectives. *Best Pract Res Clin Rheumatol* 2012;26:505–33.
20. Lamkanfi M, Dixit VM. Inflammasomes and their roles in health and disease. *Annu Rev Cell Dev Biol* 2012;28:137–61.
48. Ter Haar N, Lachmann H, Özen S, Woo P, Uziel Y, Modesto C, et al. Treatment of autoinflammatory diseases: results from the Eurofever Registry and a literature review. *Ann Rheum Dis* 2012;72:678–85.
55. Van der Hilst JCH, Bodar EJ, Barron KS, Frenkel J, Drenth JP, van der Meer JW, et al. Long-term follow-up, clinical features, and quality of life in a series of 103 patients with hyperimmunoglobulinemia D syndrome. *Medicine (Baltimore)* 2008;87:301–10.
70. Borzutzky A, Fried A, Chou J, Bonilla FA, Kim S, Dedeoglu F. NOD2-associated diseases: bridging innate immunity and autoinflammation. *Clin Immunol* 2010;134:251–61.
77. Naik HB, Cowen EW. Autoinflammatory pustular neutrophilic diseases. *Dermatol Clin* 2013;31:405–25.
86. Stojanov S, Lapidus S, Chitkara P, Feder H, Salazar JC, Fleisher TA, et al. Periodic fever, aphthous stomatitis, pharyngitis, and adenitis (PFAPA) is a disorder of innate immunity and Th1 activation responsive to IL-1 blockade. *Proc Natl Acad Sci U S A* 2011;108:7148–53.
98. Wurster VM, Carlucci JG, Feder HM, Edwards KM. Long-term follow-up of children with periodic fever, aphthous stomatitis, pharyngitis, and cervical adenitis syndrome. *J Pediatr* 2011;159:958–64.

## REFERENCES

- Caso F, Rigante D, Vitale A, Lucherini OM, Costa L, Atteno M, et al. Monogenic autoinflammatory syndromes: state of the art on genetic, clinical, and therapeutic issues. *Int J Rheumatol* 2013;2013:513782.
- De Jesus AA, Goldbach-Mansky R. Monogenic autoinflammatory diseases: concept and clinical manifestations. *Clin Immunol* 2013;147:155–74.
- Ozen S, Bilginer Y. A clinical guide to autoinflammatory diseases: familial Mediterranean fever and next-of-kin. *Nat Rev Rheumatol* 2014;10:135–47.
- Hashkes PJ, Toker O. Autoinflammatory syndromes. *Pediatr Clin N Am* 2012;59:447–70.
- Masters SL, Simon A, Aksentjevich I, Kastner DL. Horror autoinflammaticus: the molecular pathophysiology of autoinflammatory disease (\*). *Annu Rev Immunol* 2009;27:621–68.
- Bader-Meunier B, Florkin B, Sibilia J, Acquaviva C, Hachulla E, Grateau G, et al. Mevalonate kinase deficiency: a survey of 50 patients. *Pediatrics* 2011;128:e152–9.
- Zen M, Gatto M, Domeneghetti M, Palma L, Borella E, Iaccarino L, et al. Clinical guidelines and definitions of autoinflammatory diseases: contrasts and comparisons with autoimmunity – A comprehensive review. *Clin Rev Allergy Immunol* 2013;45:227–35.
- Boisson B, Laplantine E, Prando C, Giliani S, Israelsson E, Xu Z, et al. Immunodeficiency, autoinflammation and amylopectinosis in humans with inherited HOIL-1 and LUBAC deficiency. *Nat Immunol* 2012;13:1178–86.
- McGonagle D, McDermott MF. A proposed classification of the immunological diseases. *PLoS Med* 2006;3:1242–8.
- Grateau G, Hentgen V, Stojanovic KS, Jéru I, Amselem S, Steichen O. How should we approach classification of autoinflammatory diseases? *Nat Rev Rheumatol* 2013;9:624–9.
- Kanazawa N. Rare hereditary autoinflammatory disorders: towards an understanding of critical in vivo inflammatory pathways. *J Dermatol Sci* 2012;66:183–9.
- Touitou I, Koné-Paut I. Autoinflammatory diseases. *Best Pract Res Clin Rheumatol* 2008;22:811–29.
- Bodar EJ, Drenth JPH, Van Der Meer JWM, Simon A. Dysregulation of innate immunity: hereditary periodic fever syndromes. *Br J Haematol* 2009;144:279–302.
- Milhavet F, Cuisset L, Hoffman HM, Slim R, El-Shanti H, Aksentjevich I, et al. The infers autoinflammatory mutation online registry: update with new genes and functions. *Hum Mutat* 2008;29:803–8.
- Gattorno M, Sormani MP, D’Osualdo A, Pelagatti MA, Caroli F, Federici S, et al. A diagnostic score for molecular analysis of hereditary autoinflammatory syndromes with periodic fever in children. *Arthritis Rheum* 2008;58:1823–32.
- Simon A, van der Meer JW, Vesely R, Myrdal U, Yoshimura K, Duys P, et al. Approach to genetic analysis in the diagnosis of hereditary autoinflammatory syndromes. *Rheumatology* 2006;45:269–73.
- Savic S, Dickie LJ, Wittmann M, McDermott MF. Autoinflammatory syndromes and cellular responses to stress: pathophysiology, diagnosis and new treatment perspectives. *Best Pract Res Clin Rheumatol* 2012;26:505–33.
- Ryan JG, Kastner DL. Fevers, genes, and innate immunity. *Curr Top Microbiol Immunol* 2008;321:169–84.
- Martinon F, Burns K, Tschopp J. The inflammasome: a molecular platform triggering activation of inflammatory caspases and processing of proIL- $\beta$ . *Mol Cell* 2002;10:417–26.
- Lamkanfi M, Dixit VM. Inflammasomes and their roles in health and disease. *Annu Rev Cell Dev Biol* 2012;28:137–61.
- Ozen S. Familial mediterranean fever: revisiting an ancient disease. *Eur J Pediatr* 2003;162:449–54.
- Soriano A, Manna R. Familial Mediterranean fever: new phenotypes. *Autoimmun Rev* 2012;12:31–7.
- Lachmann HJ, Sengül B, Yavuzşen TU, Booth DR, Booth SE, Bybee A, et al. Clinical and sub-clinical inflammation in patients with familial Mediterranean fever and in heterozygous carriers of MEFV mutations. *Rheumatology* 2006;45:746–50.
- Pras E, Aksentjevich I, Levy E, Gruberg L, Prosen L, Dean M, et al. The gene causing familial mediterranean fever maps to the short arm of chromosome 16 in Druze and Moslem Arab families. *Hum Genet* 1994;94:576–7.
- The International FMF Consortium. Ancient missense mutations in a new member of the RoRet gene family are likely to cause familial Mediterranean fever. *Cell* 1997;90:797–807.
- French FMF Consortium. A candidate gene for familial Mediterranean fever. *Nat Genet* 1997;17:25–31.
- Booth DR, Lachmann HJ, Gillmore JD, Booth SE, Hawkins PN. Prevalence and significance of the familial Mediterranean fever gene mutation encoding pyrin Q148. *QJM* 2001;94:527–31.
- Bhat A, Naguwa SM, Gershwin ME. Genetics and new treatment modalities for familial Mediterranean fever. *Ann N Y Acad Sci* 2007;1110:201–8.
- Tunca M, Akar S, Onen F, Ozdogan H, Kasapcopur O, Yalcinkaya F, et al. Familial Mediterranean fever (FMF) in Turkey: results of a nationwide multicenter study. *Medicine (Baltimore)* 2005;84:1–11.
- Lidar M, Livneh A. Familial mediterranean fever: clinical, molecular and management advancements. *Neth J Med* 2007;65:318–24.
- Cantarini L, Rigante D, Brizi MG, Lucherini OM, Sebastiani GD, Vitale A, et al. Clinical and biochemical landmarks in systemic auto-inflammatory diseases. *Ann Med* 2012;44:664–73.
- Kessel C, Holzinger D, Foell D. Phagocyte-derived S100 proteins in autoinflammation: putative role in pathogenesis and usefulness as biomarkers. *Clin Immunol* 2013;147:229–41.
- Livneh A, Langevitz P, Zemer D, Zaks N, Kees S, Lidar T, et al. Criteria for the diagnosis of familial Mediterranean fever. *Arthritis Rheum* 1997;40:1879–85.
- Yalçınkaya F, Ozen S, Özçakar ZB, Aktay N, Cakar N, Düzova A, et al. A new set of criteria for the diagnosis of familial Mediterranean fever in childhood. *Rheumatology (Oxford)* 2009;48:395–8.
- Imirzalioglu N, Dursun A, Tastan B, Soysal Y, Yakicier MC. MEFV gene is a probable susceptibility gene for Behçet’s disease. *Scand J Rheumatol* 2005;34:56–8.
- Lane T, Loeffler JM, Rowczenio DM, Gilbertson JA, Bybee A, Russell TL, et al. AA amyloidosis complicating the hereditary periodic fever syndromes. *Arthritis Rheum* 2013;65:1116–21.
- Ozen S, Demirkaya E, Amaryan G, Koné-Paut I, Polat A, Woo P, et al. Results from a multi-centre international registry of familial Mediterranean fever: impact of environment on the expression of a monogenic disease in children. *Ann Rheum Dis* 2014;73:662–7.
- Padah S, Gerstein M, Berkun Y. Colchicine is a safe drug in children with familial Mediterranean fever. *J Pediatr* 2012;161:1142–6.
- Roubille F, Kritikou E, Busseuil D, Barrere-Lemaire S, Tardif JC. Colchicine: an old wine in a new bottle? *Antiinflamm Antiallergy Agents Med Chem* 2013;12:14–23.
- Ozturk MA, Kanbay M, Kasapoglu B, Onat AM, Guz G, Furst DE, et al. Therapeutic approach to familial Mediterranean fever: a review update. *Clin Exp Rheumatol* 2011;29:577–86.
- Williamson LM, Hull D, Mehta R, Reeves WG, Robinson BH, Toghil PJ. Familial hibernian fever. *Q J Med* 1982;51:469–80.
- McDermott MF, Aksentjevich I, Galon J, McDermott EM, Ogunkolade BW, Centola M, et al. Germline mutations in the extracellular domains of the 55 kDa TNF receptor, TNFR1, define a family of dominantly inherited autoinflammatory syndromes. *Cell* 1999;97:133–44.
- Lobito AA, Kimberley FC, Muppidi JR, Komarow H, Jackson AJ, Hull KM, et al. Abnormal disulfide-linked oligomerization results in ER retention and altered signaling by TNFR1 mutants in TNFR1-associated periodic fever syndrome (TRAPS). *Blood* 2006;108:1320–7.
- Lobito AA, Gabriel TL, Medema JP, Kimberley FC. Disease causing mutations in the TNF and TNFR superfamilies: focus on molecular mechanisms driving disease. *Trends Mol Med* 2011;17:494–505.
- Ravet N, Rouaghe S, Dodé C, Bienvenu J, Stirnemann J, Lévy P, et al. Clinical significance of P46L and R92Q substitutions in the tumour necrosis factor superfamily 1A gene. *Ann Rheum Dis* 2006;65:1158–62.
- Tchernitchko D, Chiminiggi M, Galactéros F, Préhu C, Segbena Y, Coulibaly H, et al. Unexpected high frequency of P46L TNFRSF1A allele in sub-Saharan West African populations. *Eur J Hum Genet* 2005;13:513–15.
- Stojanov S, McDermott MF. The tumour necrosis factor receptor-associated periodic syndrome: current concepts. *Expert Rev Mol Med* 2005;7:1–18.
- Ter Haar N, Lachmann H, Özen S, Woo P, Uziel Y, Modesto C, et al. Treatment of autoinflammatory diseases: results from the Eurofever Registry and a literature review. *Ann Rheum Dis* 2012;72:678–85.
- Van der Meer JW, Vossen JM, Radl J, van Nieuwkoop JA, Meyer CJ, Lobatto S, et al. Hyperimmunoglobulinemia D and periodic fever: a new syndrome. *Lancet* 1984;1:1087–90.
- Houten SM, Kuis W, Duran M, de Koning TJ, van Royen-Kerkhof A, Romeijn GJ, et al. Mutations in MVK, encoding mevalonate kinase, cause hyperimmunoglobulinemia D and periodic fever syndrome. *Nat Genet* 1999;22:175–7.
- Drenth JP, Cuisset L, Grateau G, Vasseur C, van de Velde-Visser SD, de Jong JG, et al. Mutations in the gene encoding mevalonate kinase cause hyper-IgD and periodic fever syndrome.

- International Hyper-IgD Study Group. *Nat Genet* 1999;22:178–81.
52. Haas D, Hoffmann GF. Mevalonate kinase deficiencies: from mevalonic aciduria to hyperimmunoglobulinemia D syndrome. *Orphanet J Rare Dis* 2006;1:13.
  53. Houten SM, Frenkel J, Waterham HR. Isoprenoid biosynthesis in hereditary periodic fever syndromes and inflammation. *Cell Mol Life Sci* 2003;60:1118–34.
  54. Vuch J, Marcuzzi A, Bianco AM, Tommasini A, Zanin V, Crovella S. Evolutionary hypothesis of the mevalonate kinase deficiency. *Med Hypotheses* 2013;80:67–9.
  55. Van der Hilst JCH, Bodar EJ, Barron KS, Frenkel J, Drenth JP, van der Meer JW, et al. Long-term follow-up, clinical features, and quality of life in a series of 103 patients with hyperimmunoglobulinemia D syndrome. *Medicine (Baltimore)* 2008;87:301–10.
  56. Masters SL, Lobito AA, Chae J, Kastner DL. Recent advances in the molecular pathogenesis of hereditary recurrent fevers. *Curr Opin Allergy Clin Immunol* 2006;6:428–33.
  57. Kile RL, Rusk RH. A case of cold urticaria with unusual family history. *JAMA* 1940;114:1067–8.
  58. Muckle TJ, Wells M. Urticaria, deafness, and amyloidosis: a new heredo-familial syndrome. *Q J Med* 1962; 31:235–48.
  59. Ansell MB, Bywaters EG, Elderkin FM. Familial arthropathy with rash, uveitis and mental retardation. *Proc R Soc Med* 1975; 68: 584–5.
  60. Hoffman HM, Mueller JL, Broide DH, Wanderer AA, Kolodner RD. Mutation of a new gene encoding a putative pyrin-like protein causes familial cold autoinflammatory syndrome and Muckle-Wells syndrome. *Nat Genet* 2001;29:301–5.
  61. Tanaka N, Izawa K, Saito MK, Sakuma M, Oshima K, Ohara O, et al. High incidence of NLRP3 somatic mosaicism in patients with chronic infantile neurologic, cutaneous, articular syndrome: results of an international multicenter collaborative study. *Arthritis Rheum* 2011;63:3625–32.
  62. Shinkai K, McCalmont TH, Leslie KS. Cryopyrin-associated periodic syndromes and autoinflammation. *Clin Exp Dermatol* 2008; 33:1–9.
  63. Krause K, Grattan CE, Bindslev-Jensen C, Gattorno M, Kallinich T, de Koning HD, et al. How not to miss autoinflammatory diseases masquerading as urticaria. *Eur J Allergy Clin Immunol* 2012;67:1465–74.
  64. Kuemmerle-Deschner JB, Koitschev A, Ummenhofer K, Hansmann S, Plontke SK, Koitschev C, et al. Hearing loss in Muckle-Wells syndrome. *Arthritis Rheum* 2013;65: 824–31.
  65. Lachmann HJ, Kone-Paut I, Kuemmerle-Deschner JB, Leslie KS, Hachulla E, Quartier P, et al. Use of canakinumab in the cryopyrin-associated periodic syndrome. *N Engl J Med* 2009;360:2416–25.
  66. Jéru I, Duquesnoy P, Fernandes-Alnemri T, Cochet E, Yu JW, Lackmy-Port-Lis M, et al. Mutations in NALP12 cause hereditary periodic fever syndromes. *Proc Natl Acad Sci U S A* 2008;105:1614–19.
  67. Aksentijevich I, Masters SL, Ferguson PJ, Dancey P, Frenkel J, van Royen-Kerkhoff A, et al. An autoinflammatory disease with deficiency of the interleukin-1-receptor antagonist. *N Engl J Med* 2009;360:2426–37.
  68. Reddy S, Jia S, Geoffrey R, Lorier R, Suchi M, Broeckel U, et al. An autoinflammatory disease due to homozygous deletion of the IL1RN locus. *N Engl J Med* 2009;360:2438–44.
  69. Rosé CD, Doyle TM, McIlvain-Simpson G, Coffman JE, Rosenbaum JT, Davey MP, et al. Blau syndrome mutation of CARD15/NOD2 in sporadic early onset granulomatous arthritis. *J Rheumatol* 2005;32:373–5.
  70. Borzutzky A, Fried A, Chou J, Bonilla FA, Kim S, Dedeoglu F. NOD2-associated diseases: bridging innate immunity and autoinflammation. *Clin Immunol* 2010;134:251–61.
  71. Shaw MH, Reimer T, Kim YG, Nuñez G. NOD-like receptors (NLRs): bona fide intracellular microbial sensors. *Curr Opin Immunol* 2008;20:377–82.
  72. Martin TM, Zhang Z, Kurz P, Rosé CD, Chen H, Lu H, et al. The NOD2 defect in Blau syndrome does not result in excess interleukin-1 activity. *Arthritis Rheum* 2009;60:611–18.
  73. Majeed HA, Kalaawi M, Mohanty D, Teebi AS, Tunjekar MF, al-Gharbawy F, et al. Congenital dyserythropoietic anemia and chronic recurrent multifocal osteomyelitis in three related children and the association with Sweet syndrome in two siblings. *J Pediatr* 1989; 115:730–4.
  74. Ferguson PJ, Chen S, Tayeh MK, Ochoa L, Leal SM, Pelet A, et al. Homozygous mutations in LPIN2 are responsible for the syndrome of chronic recurrent multifocal osteomyelitis and congenital dyserythropoietic anaemia (Majeed syndrome). *J Med Genet* 2005;42:551–7.
  75. Herlin T, Fiirgaard B, Bjerre M, Kerndrup G, Hasle H, Bing X, Ferguson PJ. Efficacy of anti-IL-1 treatment in Majeed syndrome. *Ann Rheum Dis* 2013;72:410–3.
  76. Lindor NM, Arsenault TM, Solomon H, Seidman CE, McEvoy MT. A new autosomal dominant disorder of pyogenic sterile arthritis, pyoderma gangrenosum, and acne: PAPA syndrome. *Mayo Clin Proc* 1997;72:611–15.
  77. Naik HB, Cowen EW. Autoinflammatory pustular neutrophilic diseases. *Dermatol Clin* 2013;31:405–25.
  78. Wise CA, Gillum JD, Seidman CE, Lindor NM, Veile R, Bashiardes S, et al. Mutations in CD2BP1 disrupt binding to PTP PEST and are responsible for PAPA syndrome, an autoinflammatory disorder. *Hum Mol Genet* 2002; 11:961–9.
  79. Shoham NG, Centola M, Mansfield E, Hull KM, Wood G, Wise CA, et al. Pyrin binds the PSTPIP1/CD2BP1 protein, defining familial Mediterranean fever and PAPA syndrome as disorders in the same pathway. *Proc Natl Acad Sci U S A* 2003;100:13501–6.
  80. Demidowich AP, Freeman AF, Kuhns DB, Aksentijevich I, Gallin JI, Turner ML, et al. Genotype, phenotype, and clinical course in five patients with PAPA syndrome (pyogenic sterile arthritis, pyoderma gangrenosum, and acne). *Arthritis Rheum* 2012;64:2022–7.
  81. Marshall GS, Edwards KM, Butler J, Lawton AR. Syndrome of periodic fever, pharyngitis, and aphthous stomatitis. *J Pediatr* 1987;110: 43–6.
  82. Tasher D, Somekh E, Dalal I. PFAPA syndrome: new clinical aspects disclosed. *Arch Dis Child* 2006;91:981–4.
  83. Thomas KT, Feder HM Jr, Lawton AR, Edwards KM. Periodic fever syndrome in children. *J Pediatr* 1999;135:15–21.
  84. Padeh S, Breznik N, Zemer D, Pras E, Livneh A, Langevitz P, et al. Periodic fever, aphthous stomatitis, pharyngitis, and adenopathy syndrome: clinical characteristics and outcome. *J Pediatr* 1999;135:98–101.
  85. Hofer M, Pillet P, Cochard MM, Berg S, Krol P, Kone-Paut I, et al. International periodic fever, aphthous stomatitis, pharyngitis, cervical adenitis syndrome cohort: description of distinct phenotypes in 301 patients. *Rheumatol (Oxford)* 2014;53:1125–9.
  86. Stojanov S, Lapidus S, Chitkara P, Feder H, Salazar JC, Fleisher TA, et al. Periodic fever, aphthous stomatitis, pharyngitis, and adenitis (PFAPA) is a disorder of innate immunity and Th1 activation responsive to IL-1 blockade. *Proc Natl Acad Sci U S A* 2011;108:7148–53.
  87. Valenzuela PM, Araya A, Pérez CI, Maul X, Serrano C, Beltrán C, et al. Profile of inflammatory mediators in tonsils of patients with periodic fever, aphthous stomatitis, pharyngitis, and cervical adenitis (PFAPA) syndrome. *Clin Rheumatol* 2013;32:1743–9.
  88. Vigo G, Zulian F. Periodic fevers with aphthous stomatitis, pharyngitis, and adenitis (PFAPA). *Autoimmun Rev* 2012;12:52–5.
  89. Peridis S, Pilgrim G, Koudounakis E, Athanasopoulos I, Houlakis M, Parpounas K. PFAPA syndrome in children: a meta-analysis on surgical versus medical treatment. *Int J Pediatr Otorhinolaryngol* 2010;74:1203–8.
  90. Wong KK, Finlay JC, Moxham JP. Role of tonsillectomy in PFAPA syndrome. *Arch Otolaryngol Head Neck Surg* 2008;134:16–19.
  91. Licameli G, Jeffrey J, Luz J, Jones D, Kenna M. Effect of adenotonsillectomy in PFAPA syndrome. *Arch Otolaryngol Head Neck Surg* 2008;134:136–40.
  92. Renko M, Salo E, Putto-Laurila A, Saxen H, Mattila PS, Luotonen J, et al. A randomized, controlled trial of tonsillectomy in periodic fever, aphthous stomatitis, pharyngitis, and adenitis syndrome. *J Pediatr* 2007;151:289–92.
  93. Garavello W, Romagnoli M, Gaini RM. Effectiveness of adenotonsillectomy in PFAPA syndrome: a randomized study. *J Pediatr* 2009; 155:250–3.
  94. Feder HM. Cimetidine treatment for periodic fever associated with aphthous stomatitis, pharyngitis and cervical adenitis. *Pediatr Infect Dis J* 1992;11:318–21.
  95. Akelma AZ, Cizmeci MN, Kanburuglu MK, Mete E, Bozkaya D, Tufan N, et al. Is PFAPA syndrome really a sporadic disorder or is it genetic? *Med Hypotheses* 2013;81:279–81.
  96. Dagan E, Gershoni-Baruch R, Khatib I, Mori A, Brik R, MEFV, TNF1 $\alpha$ , CARD15 and NLRP3 mutation analysis in PFAPA. *Rheumatol Int* 2010;30:633–6.
  97. Berkun Y, Levy R, Hurwitz A, Meir-Harel M, Lidar M, Livneh A, et al. The familial Mediterranean fever gene as a modifier of periodic fever, aphthous stomatitis, pharyngitis, and adenopathy syndrome. *Semin Arthritis Rheum* 2011;40:467–72.
  98. Wurster VM, Carlucci JG, Feder HM, Edwards KM. Long-term follow-up of children with periodic fever, aphthous stomatitis, pharyngitis, and cervical adenitis syndrome. *J Pediatr* 2011;159:958–64.
  99. Marrakchi S, Guigue P, Renshaw BR, Puel A, Pei XY, Fraitag S, et al. Interleukin-36-receptor antagonist deficiency and generalized pustular psoriasis. *N Engl J Med* 2011;365:620–8.
  100. Sugiura K. The genetic background of generalized pustular psoriasis: IL36RN mutations and CARD14 gain-of-function variants. *J Dermatol Sci* 2014;74:187–92.

101. Jordan CT, Cao L, Roberson ED, Duan S, Helms CA, Nair RP, et al. Rare and common variants in CARD14, encoding an epidermal regulator of NF- $\kappa$ B, in psoriasis. *Am J Hum Genet* 2012;90:796–808.
102. Fuchs-Telem D, Sarig O, van Steensel MA, Isakov O, Israeli S, Noursbeck J, et al. Familial pityriasis rubra pilaris is caused by mutations in CARD14. *Am J Hum Genet* 2012;91:163–70.
103. Zhou Q, Yang D, Ombrello AK, Zavialov AV, Toro C, Zavialov AV, et al. Early-onset stroke and vasculopathy associated with mutations in ADA2. *N Engl J Med* 2014;370:911–20.
104. Navon Elkan P, Pierce SB, Segel R, Walsh T, Barash J, Padeh S, et al. Mutant adenosine deaminase 2 in a polyarteritis nodosa vasculopathy. *N Engl J Med* 2014;370:921–31.
105. Kanazawa N, Kunimoto K, Mikita N, Furu-kawa F, Yoshiura K-I, Ida H. Nakajo-Nishimura syndrome (familial Japanese fever) and related autoinflammatory disorders accompanied with lipodystrophy. *Inflamm Res* 2011;60:S265.
106. Agarwal AK, Xing C, DeMartino GN, Mizrachi D, Hernandez MD, Sousa AB, et al. PSMB8 encoding the  $\beta$ 5i proteasome subunit is mutated in joint contractures, muscle atrophy, microcytic anemia, and panniculitis-induced lipodystrophy syndrome. *Am J Hum Genet* 2010;87:866–72.
107. Arima K, Kinoshita A, Mishima H, Kanazawa N, Kaneko T, Mizushima T, et al. Proteasome assembly defect due to a proteasome subunit beta type 8 (PSMB8) mutation causes the autoinflammatory disorder, Nakajo-Nishimura syndrome. *Proc Natl Acad Sci U S A* 2011;108:14914–19.
108. Kanazawa N, et al. A mutation of the immunoproteasome subunit gene is responsible for Nakajo-Nishimura syndrome, a distinct auto-inflammatory syndrome with periodic fever, skin eruptions and partial lipodystrophy. *J Invest Dermatol* 2011;131:S8.
109. Liu Y, Ramot Y, Torrelo A, Paller AS, Si N, Babay S, et al. Mutations in proteasome subunit  $\beta$  type 8 cause chronic atypical neutrophilic dermatosis with lipodystrophy and elevated temperature with evidence of genetic and phenotypic heterogeneity. *Arthritis Rheum* 2012;64:895–907.
110. Liu Y, Jesus AA, Marrero B, Yang D, Ramsey SE, Montealegre Sanchez GA, et al. Activated STING in a vascular and pulmonary syndrome. *N Engl J Med* 2014;371:507–18.
111. Rinnenthal JL, Goebel HH, Preuße C, Lebenheim L, Schumann M, Moos V, et al. Inflammatory myopathy with abundant macrophages (IMAM): the immunology revisited. *Neuromuscul Disord* 2014;24:151–5.
112. Melki I, Lambot K, Jonard L, Couloigner V, Quartier P, Neven B, et al. Mutation in the SLC29A3 gene: a new cause of a monogenic, autoinflammatory condition. *Pediatrics* 2013;131:e1308-13.
113. Holzinger D, Lohse P, Faßl S, Austermann J, Vogl T, de Jager W, et al. Impact of PSTPIP1 mutations on clinical phenotype. *Pediatric Rheumatology* 2013;11(Suppl. 1):A158.
114. Zhang SQ, Jiang T, Li M, Zhang X, Ren YQ, Wei SC, et al. Exome sequencing identifies MVK mutations in disseminated superficial actinic porokeratosis. *Nat Genet* 2012;44:1156–60.
115. Levy M, Arion A, Berrebi D, Cuisset L, Jeanne-Pasquier C, Bader-Meunier B, et al. Severe early-onset colitis revealing mevalonate kinase deficiency. *Pediatrics* 2013;132:e779–83.
116. Siemiatkowska AM, van den Born LI, van Hagen PM, Stoffels M, Neveling K, Henkes A, et al. Mutations in the mevalonate kinase (MVK) gene cause nonsyndromic retinitis pigmentosa. *Ophthalmology* 2013;120:2697–705.
117. Perricone C, Colafrancesco S, Mazor RD, Soriano A, Agmon-Levin N, Shoenfeld Y, et al. Autoimmune/inflammatory syndrome induced by adjuvants (ASIA) 2013: unveiling the pathogenic, clinical and diagnostic aspects. *J Autoimmun* 2013;47:1–16.



# Immunoglobulin Therapy

HEATHER K. LEHMAN | MARK BALLOW

## KEY POINTS

- Replacement immune globulin, administered by intravenous or subcutaneous route, is indicated as replacement therapy in patients with antibody immunodeficiency disorders.
- Dosing intravenous immune globulin (IVIG) to target higher IgG troughs (>700–1,000 mg/dL) may be associated with decreased rate of infections and improved pulmonary outcomes in primary immune deficiency patients.
- IVIG is not a generic drug and IVIG products are not interchangeable. Product differences may lead to differences in tolerability and side-effects for individual patients.
- Minor side-effects of IVIG are common. Serious adverse effects, though relatively rare at standard replacement doses of IVIG, may include hemolysis, thromboembolic events and acute renal failure.
- Many mechanisms for the effects of IVIG on immune modulation have been described. These mechanisms are not mutually exclusive and most likely work in concert, depending on the dose of IVIG administered and the specific inflammatory disease process.

## Introduction

At the beginning of World War II, Cohn and colleagues from Harvard University developed an ethanol fractionation method to separate plasma proteins into stable fractions.<sup>1</sup> Fraction II was an antibody rich fraction that could be administered in small amounts intramuscularly and had a protective effect against measles and hepatitis A. In 1952, Bruton described the first case of agammaglobulinemia and showed that replacement with Cohn's fraction II immunoglobulin was effective in the treatment of these patients.<sup>2</sup> However, the replacement could be done only intramuscularly; intravascular administration caused serious side-effects. In the early 1960s the Swiss Red Cross Laboratories developed methods to adapt the Cohn fraction II immunoglobulin for intravenous use. In 1981 the first commercial intravenous immunoglobulin became available in the USA.

## Immunoglobulin Replacement Therapy in Primary Immunodeficiency

The goal of immunoglobulin replacement therapy in patients with primary immunodeficiency is to provide adequate

antibodies to prevent infections and long-term complications, especially pulmonary disease. Patients with recurrent infections and profound hypogammaglobulinemia and/or defective antibody production may be candidates for immunoglobulin replacement therapy,<sup>3</sup> either with intravenous immune serum globulin (IVIG) or subcutaneous immunoglobulin (SCIG). It is very important to evaluate the ability of the patient to produce specific antibodies to polysaccharide or protein antigens. Immunoglobulin replacement therapy should be considered only in patients with deficiencies in antibody formation; it is not indicated in patients solely having low levels of immunoglobulin or IgG subclasses. The uses approved by the US Food and Drug Administration (FDA) for IVIG as replacement or adjunct therapy in patients with immune deficiency, recurrent infections or autoimmune and inflammatory disorders are shown in [Box 15-1](#).

## PREPARATION OF INTRAVENOUS IMMUNOGLOBULIN ([Box 15-2](#))

Most IVIG preparations are derived from plasma by Cohn's ethanol fractionation method or its Cohn-Oncley modification.<sup>4</sup> This fractionation process obtains four fractions. Fraction II is the immunoglobulin-rich fraction containing 95% to 99% IgG. There are small varying amounts of IgM, IgA and other proteins.<sup>5</sup> Unmodified Cohn fraction II can only be given intramuscularly. The side-effects of Cohn fraction II when given intravenously are thought to result from aggregation of the IgG molecules and its complement fixing activity, which can produce a severe systemic reaction. A number of approaches have been used to further purify the IgG fraction including caprylate precipitation, octanoic acid precipitation, anion chromatography or polyethylene glycol ([Table 15-1](#)). Other additives after purification, such as amino acids, stabilize the IgG molecules from reaggregation, making it suitable for intravenous use. Almost all products available today in the USA are liquids, either 5% or 10%, and are FDA approved for intravenous and/or subcutaneous administration. One liquid 20% product is only suitable for administration via the subcutaneous route ([Table 15-1](#)). Incubation at low pH or treatment with solvent and detergent, pasteurization, depth filtration and nanofiltration are important steps for viral removal and inactivation.

IVIG is made from pooled plasma from at least 10,000 donors, but each pool, by FDA guidelines, may contain up to 60,000 donors, and contains a broad spectrum of antibodies with biologic activities especially for infectious pathogens. It contains at least 90% intact monomeric IgG with a normal ratio of IgG subclasses, and is free of aggregates. The biologic activity of the IgG is maintained, especially for Fc-mediated function, and it contains no infectious agents or other potentially harmful contaminants. Although there is no standardization for the titer

### BOX 15-1 FDA-APPROVED USES OF IVIG THERAPY IN PATIENTS WITH IMMUNODEFICIENCY DISORDERS, INFECTION AND INFLAMMATORY PROCESSES

1. Primary immunodeficiency disease or primary antibody immunodeficiency – replacement therapy to prevent and/or control infection
2. Idiopathic thrombocytopenic purpura (ITP) – indicated to prevent and/or control bleeding
3. Kawasaki disease – indicated for the prevention of coronary artery aneurysms
4. B cell chronic lymphocytic leukemia (CLL) – indicated for patients with hypogammaglobulinemia to reduce and/or prevent recurrent bacterial infections
5. Bone marrow transplantation – to decrease the risk of infection, interstitial pneumonia and acute GVHD
6. Pediatric HIV-1 infection – to decrease the frequency and severity of bacterial infections
7. Chronic inflammatory demyelinating polyneuropathy (CIDP) – to improve neuromuscular impairment and for maintenance therapy to prevent relapse
8. Multifocal motor neuropathy – to improve neuromuscular impairment and for maintenance therapy to prevent relapse

### BOX 15-2 FEATURES OF INTRAVENOUS IMMUNE SERUM GLOBULIN (IVIG)

- Cold ethanol fractionation (Cohn fraction II)
- >95% IgG; >90% monomeric IgG
- Traces of other immunoglobulins, e.g. IgA and IgM, and serum proteins
- Addition of an amino acid to stabilize IgG from aggregation
- Intact Fc receptor biological function:
  - opsonization and phagocytosis
  - complement activation
- Normal half-life for serum IgG
- Normal proportion of IgG subclasses
- Broad spectrum of antibodies to bacterial and viral agents

of specific antibodies against common organisms such as *Streptococcus pneumoniae* and *Haemophilus influenzae*, each lot must contain adequate levels of antibody to certain pathogens, e.g. measles. Specific antibodies in IVIG products may vary slightly from manufacturer to manufacturer and from lot to lot but they are generally comparable.<sup>6</sup> Some products containing very low amounts of IgA may be beneficial in some IgA-deficient patients with antibodies to IgA to minimize the risk of possible anaphylactic reactions,<sup>7</sup> though the role of anti-IgA antibodies in causing anaphylaxis to IVIG is a subject of controversy.<sup>8</sup>

The half-life of antibodies in the IVIG product varies. It depends on the isotype and the subclass of the antibody. Total IgG has a half-life of approximately 17 to 30 days.<sup>9,10</sup> However, the half-life of IgG3 is much shorter (7.5–9 days)<sup>10,11</sup> compared to IgG1 and IgG2 which have a half-life of approximately 27 to 30 days. Generally, it should take about 3 months after beginning monthly IVIG infusions or a dosage change to reach equilibrium (steady state).<sup>6</sup> Infusing increased amounts of IVIG results in a more rapid catabolic rate since the catabolism of IgG is concentration dependent.<sup>11</sup> This process is mediated by the Fc receptors on phagocytic cells.<sup>12</sup>

## DOSAGE

The recommended dose for IVIG as replacement therapy is generally 400–600 mg/kg/month given every 4 weeks in patients with primary immune deficiency. A higher dose of immunoglobulin can lead to higher peak and trough levels of serum IgG.<sup>13</sup> On average, peak serum IgG levels increase approximately 250 mg/dL<sup>13</sup> and trough levels increase 100 mg/dL<sup>14</sup> for each 100 mg/kg of IVIG infused.

Several trials from the 1980s and 1990s demonstrated improved efficacy of current standard dose IVIG versus low-dose therapy (less than 200 mg/kg). In 1987 Bernatowska et al<sup>15</sup> compared 150 mg/kg with 500 mg/kg, and showed that the higher dose decreased the days of fever and days on antibiotics, and improved pulmonary function. The benefits of the higher dose of IVIG were more significant in children who had severe clinical symptoms. In a randomized cross-over study, Roifman et al<sup>16</sup> administered either 200 mg/kg or 600 mg/kg of IVIG to 12 patients with antibody deficiency and chronic lung disease. Pulmonary function improved on the higher doses of IVIG therapy. In 1992 Liese et al<sup>17</sup> reported outcomes of 29 patients with X-linked agammaglobulinemia who received immunoglobulin replacement therapy between 1965 and 1990. They showed a significant decrease in the incidence of pneumonias and the number of hospitalized days in patients receiving 350–600 mg/kg IVIG every 3 weeks compared with patients receiving less than 200 mg/kg IVIG every 3 weeks or 100 mg/kg of IM gammaglobulin every 3 weeks. The improvements were more evident when the high-dose IVIG was initiated before the age of 5 years. Eijkhout et al<sup>18</sup> studied the effect of two different doses of IVIG on the incidence of recurrent infections in patients with primary immune deficiency in a randomized, double-blinded, multicenter cross-over study. Compared with standard doses of IVIG (300 mg/kg every 4 weeks for adults, and 400 mg/kg every 4 weeks for children) the administration of high IVIG doses (600 mg/kg for adults, and 800 mg/kg for children) significantly reduced the number (3.5 vs 2.5 per patient) and duration (median, 33 days vs 21 days) of infections. Trough levels also increased during high-dose therapy. Importantly, the incidence and type of side-effects did not differ between the standard and high-dose therapies.

Historically, IgG trough levels of >500 mg/dL have been shown to prevent severe bacterial infections. However, Kainulainen et al<sup>19</sup> published data in 1999 on 22 patients with primary hypogammaglobulinemia and pulmonary abnormalities who were treated with IVIG. Despite adequate trough serum IgG levels (>500 mg/dL), silent and asymptomatic pulmonary changes occurred. Quartier and associates<sup>20</sup> performed a retrospective study of the clinical features and outcomes of 31 patients with X-linked agammaglobulinemia (XLA) receiving replacement IVIG therapy between 1982 and 1997. IVIG was given at doses of >250 mg/kg every 3 weeks with a mean serum trough level between 500 and 1,140 mg/dL (median 700 mg/dL). While the incidence of bacterial infections requiring hospitalizations fell from 0.4 to 0.06 per patient per year, complications of sinusitis, bronchiectasis, obstructive pulmonary disease and enteroviral meningoencephalitis still occurred. The authors suggested that more intensive therapy to maintain a higher serum IgG level, e.g. >800 mg/dL, may improve pulmonary outcome in patients with XLA.

Targeting of higher IgG trough levels has since been demonstrated to improve outcomes in hypogammaglobulinemic

**TABLE 15-1 Commercial Intravenous Immunoglobulin Preparations**

Brand (Manufacturer)	Manufacturing Process/ Antiviral Inactivation	pH	Additives	Parenteral Form and Final Concentrations	IgA Content µg/mL	Approved Method of Administration
Gammagard S/D (Baxter Corp)	Cohn-Oncley cold ethanol fractionation, ion exchange chromatography; solvent detergent treatment	6.4–7.2	2% glucose (5% solution)	Lyophilized powder 5% or 10%	<2.2 (5% solution)	Intravenous
Gammagard Liquid (Baxter Corp)	Cohn-Oncley cold ethanol fractionation, ion exchange chromatography; solvent detergent treatment, nanofiltration, low pH incubation	4.6–5.1	No sugars – stabilized with glycine	10% liquid	37	Intravenous and subcutaneous
Flebogamma DIF (Grifols Therapeutics, Inc.)	Cohn-Oncley cold ethanol fractionation, ion exchange chromatography; PEG precipitation, heat pasteurization; pH 4 treatment, solvent detergent treatment; double nanofiltration	5–6	5% D-sorbitol	5% or 10% liquid	<50 (5% solution) <100 (10% solution)	Intravenous
Carimune NF (CLS Behring)	Kistler-Nitschmann fractionation, pH 4.0 plus pepsin, nanofiltration, depth filtration	6.4–6.8	5% sucrose (3% solution)	Lyophilized powder – reconstitute to 3, 6, 9 or 12%	720 (6% solution)	Intravenous
Gamunex-C (Grifols Therapeutics, Inc.)	Cohn-Oncley cold ethanol fractionation, caprylate chromatography, anion exchange chromatography, low pH incubation, double depth filtration	4.0–4.5	No sugars – stabilized with glycine	10% liquid	46	Intravenous and subcutaneous
Gammaplex (Bio Products Laboratory)	Kistler & Nitschmann fractionation, DEAE-Sephadex chromatography, Solvent/detergent treatment, CM-Sephadex chromatography, nanofiltration, low pH incubation	4.8–5.1	5% D-sorbitol	5% liquid	<10	Intravenous
Gammaked (Kedrion Biopharma, Inc.)	Cohn-Oncley cold ethanol fractionation, caprylate chromatography, anion exchange chromatography, low pH incubation, double depth filtration	4.0–4.5	No sugars – stabilized with glycine	10% liquid	46	Intravenous and subcutaneous
BIVIGAM (Biotest Pharmaceuticals Corp.)	Cohn-Oncley cold ethanol fractionation, ultrafiltration, solvent/detergent treatment	4.0–4.6	No sugars – stabilized with glycine	10% liquid	≤200	Intravenous
Octagam (Octapharma USA, Inc.)	Cohn-Oncley cold ethanol fractionation, ion exchange chromatography, ultrafiltration, solvent/detergent treatment	5.1–6.0	Maltose 100 mg/mL	5% liquid	≤200	Intravenous
Privigen (CLS Behring)	Cold ethanol fractionation, octanoic acid fractionation, anion exchange chromatography; pH 4 treatment, nanofiltration, depth filtration	4.8	No sugars, stabilized with L-proline	10% liquid	≤25	Intravenous
Hizentra (CLS Behring)	Cold ethanol fractionation, octanoic acid fractionation, anion exchange chromatography; pH 4 treatment, nanofiltration	4.6–5.2	No sugar, stabilized with L-proline	20% liquid	≤50	Subcutaneous

Source: manufacturers' package inserts and product publications.

patients on IVIG therapy. Orange et al<sup>21</sup> performed a meta-analysis of studies evaluating trough IgG level and pneumonia incidence in primary immune deficient patients with hypogammaglobulinemia. Across all included studies, pneumonia incidence progressively declined with increasing trough IgG, with trough levels of 1,000 mg/dL associated with one fifth the incidence of pneumonia seen with trough levels of 500 mg/dL.<sup>21</sup>

There is emerging evidence that ideal trough levels to prevent infection may vary considerably from patient to patient. Bonagura et al<sup>22</sup> proposed the concept of the biologic IgG level as the minimum serum IgG level that protects an individual immune deficient patient against recurrent bacterial infections and bronchiectasis. This level is anticipated to be somewhere in the age-matched normal reference range, but is unique for the individual patient.<sup>22</sup> This concept of individualized IgG trough was supported by Lucas et al,<sup>23</sup> who showed that patients with common variable immune deficiency (CVID) required a wide range of trough IgG levels, from 500 to 1,700 mg/dL, to prevent recurrent infection. X-linked agammaglobulinemia patients required IgG troughs between 800 and 1,300 mg/dL to prevent infection.<sup>23</sup>

The number of bacterial infections may not be a sufficient indicator of adequate treatment when used alone. Pulmonary abnormalities are among the most important factors associated with morbidity and mortality in patients with humoral primary immunodeficiencies. Periodic pulmonary function testing and judicious use of high-resolution chest computed tomography should be used to monitor for adequate control or prevention of pulmonary complications of humoral immune deficiency.

## ADMINISTRATION

In patients with primary immune deficiency the replacement dose of IVIG is generally 400–600 mg/kg. The dose, manufacturer and lot number should be recorded for each infusion in order to perform look-back procedures for adverse events or other consequences. It is crucial to record all side-effects that occur during the infusion. It is also recommended to monitor liver and renal function tests periodically, approximately every 6 months. Antigen detection for hepatitis B and polymerase chain reaction (PCR) for hepatitis C should be performed, if clinically indicated.

There are several routes of administration of immunoglobulin.

### *Intravenous Administration*

The recommended rates of IVIG infusion were determined in early studies using reduced and alkylated IgG.<sup>24</sup> Such preparations caused rate-related side-effects in 50% of patients. Newer preparations are generally more tolerable, but significant side-effects such as thrombosis have been associated with higher rates of infusion. Manufacturers recommend starting rates of 0.5–1 mg/kg/min and increasing incrementally up to rates anywhere between 3.3 and 8 mg/kg/min.<sup>25–29</sup> The FDA recommends that for patients at risk of renal failure, e.g. preexisting renal insufficiency, diabetes, age greater than 65 years, volume depletion, sepsis, paraproteinemia and use of nephrotoxic drugs, or patients at risk of thromboembolic complications, the dose should be gradually increased to a more conservative 3–4 mg/kg/min maximum.

### *Subcutaneous Immunoglobulin Administration (SCIG)*

Berger et al<sup>30</sup> first described the use of the subcutaneous (SC) route for immunoglobulin replacement therapy in 1980. It was reported as safe, well tolerated and effective in achieving adequate serum IgG levels. Although used successfully in several studies,<sup>31,32</sup> it was not very popular because it was time consuming due to the slow rate of infusion (1–2 mL/hr). Home treatment with rapid subcutaneous infusion was studied more extensively in the 1990s and was demonstrated to be well tolerated, efficacious and resulting in fewer systemic side-effects than IVIG.<sup>33–36</sup> A meta-analysis of SCIG vs IVIG efficacy and safety studies demonstrated a trend toward better infection control with SCIG (though not achieving statistical significance), along with improved patient quality of life and decreased systemic adverse events when compared with IVIG therapy.<sup>37</sup> Higher and more stable trough levels have been seen with the subcutaneous administration of immunoglobulin, alleviating the fatigue and general constitutional symptoms patients have on IVIG toward the end of their 3–4 weeks dosing interval. The above qualities have made SCIG a viable alternative to IVIG for many patients, especially those with significant systemic adverse effects with IVIG.

When immunoglobulin is administered via the SC route, the dose is absorbed into the circulation and redistributed to the peripheral tissues more slowly than when given via the IV route.<sup>38</sup> One study showed that SCIG infusions (100 mg/kg of a 16.5% preparation) reach a steady state after 6 months if given weekly, or in one week if patients are first loaded with IVIG or given daily SC infusions for 5 days, prior to their maintenance weekly SCIG.<sup>39</sup>

In the USA a 20% immunoglobulin product for subcutaneous use is available and several 10% liquid products have both intravenous and subcutaneous indications (Table 15-1). The FDA required a dose adjustment in SCIG licensing studies, such that the weekly SCIG dose results in a total serum IgG exposure (area under the curve [AUC] of serum IgG versus time) equivalent to that of previous IVIG treatment.<sup>40</sup> Based on this AUC calculation, SCIG prescribing information recommends product-specific dosage increases of 37% to 53% when transitioning patients from IVIG to SCIG.<sup>25,26,41</sup> However, Berger et al<sup>42</sup> have recently shown that all US-licensed SCIG products have a similar bioavailability: 66.7% ± 1.8% of IVIG. They suggest that decreased bioavailability is a basic property of SCIG rather than the result of any manufacturing process or product concentration, and that dose adjustments are not necessary when switching from one SCIG product to another.<sup>42</sup>

Several studies from the EU, where a 1 : 1 conversion from IVIG to SCIG is standard, suggest that a dose adjustment from IVIG to SCIG may not be necessary to achieve good clinical outcomes.<sup>43,44</sup> In contrast, Haddad et al found that patients receiving SCIG doses that were 1.5 times higher than their previous IVIG doses had significantly lower rates of non-serious infections, hospitalization, antibiotic use and missed work/school activity, compared to patients that received SCIG doses identical to previous IVIG doses.<sup>45</sup> When switching a patient from IVIG to SCIG, making a dosage decision based on trough serum IgG levels and the clinical response to therapy is preferable to only taking pharmacokinetic measures into consideration.<sup>40</sup>

The technique of administering SCIG can be taught to most patients or caregivers to facilitate home self-administration.



Infusions may be given anywhere from daily to weekly or biweekly via 1 to 6 sites, depending on the total amount infused and the amount that can be accommodated in a single site (a function of body mass index). Infusion sites are usually on the abdominal wall and inner thigh. Other sites may include posterior upper arms, flanks or below the buttocks. Before infusion is started, the lines need to be checked to ensure that there is no blood return. The rate of infusion of the various SCIG products is set initially at 15–20 mL/site/hr and may subsequently be increased up to 25–30 mL/site/hr, if no adverse reactions occur. A general guideline is 0.1–0.25 mL/kg/site/hr.<sup>46</sup>

## SIDE-EFFECTS

### Rate-related Adverse Reactions

Most adverse reactions of IVIG are related to the administration of IVIG and are rate related. Common adverse events include tachycardia, chest tightness, back pain, arthralgia, myalgia, hypertension or hypotension, headache, pruritus, rash and low-grade fever (Box 15-3). More serious reactions include dyspnea, nausea, vomiting, circulatory collapse and loss of consciousness. Patients with more profound immunodeficiency or

patients with active infections have more severe reactions. Some of these reactions have been shown to be related to the complement-fixing activity of IgG aggregates in the IVIG.<sup>47</sup> In addition, the formation of oligomeric or polymeric IgG complexes can interact with Fc receptors and trigger the release of inflammatory mediators.<sup>48</sup> These adverse reactions occurred with lower frequency (10–15%) and with less severity in more recent preparations of IVIG. These reactions most commonly occur in newly diagnosed patients with hypogammaglobulinemia and in those patients who have chronic underlying infections such as sinusitis and bronchitis. One possible etiology is the binding of the infused antibodies to pathogen component antigens of the underlying chronic infection or inflammatory process. In a large prospective study of 459 antibody-deficient patients by Brennan and colleagues<sup>49</sup> of 13,508 infusions, the reaction rate was only 0.8%. There were virtually no severe reactions (0.1%).

Common reactions to IVIG, including fatigue, myalgia and headache, may be delayed and may last several hours after the infusion. Slowing the infusion rate or discontinuing therapy until symptoms subside may diminish the reaction. Pretreatment with a nonsteroidal antiinflammatory agent, e.g. ibuprofen (10 mg/kg/dose), acetaminophen (15 mg/kg/dose), diphenhydramine (1 mg/kg/dose) and/or hydrocortisone (6 mg/kg/dose, maximum 100 mg)<sup>14,47,50</sup> 1 hour before the infusion may prevent adverse reactions. If the patient continues to have adverse effects from IVIG despite pretreatment and rate change, the physician should consider changing the route of administration to subcutaneous.

Aseptic meningitis can occur with large doses, rapid infusions and in the treatment of patients with autoimmune or inflammatory diseases.<sup>51–54</sup> Interestingly, this adverse reaction rarely occurs in immunodeficient subjects.<sup>50</sup> Symptoms, including headache, stiff neck and photophobia, usually develop within 24 hours after completion of the infusion and may last 3 to 5 days. Spinal fluid pleocytosis occurs in most patients.<sup>51,52,54</sup> Long-term complications are minimal.<sup>54</sup> The etiology of aseptic meningitis is unclear but migraine has been reported as a risk factor and may be associated with recurrence despite the use of different IVIG preparations and slower rates of infusion.<sup>51</sup>

### Renal Adverse Effects

Acute renal failure is a rare but significant complication of IVIG treatment. Histopathologic findings of acute tubular necrosis, vacuolar degeneration and osmotic nephrosis are suggestive of osmotic injury to the proximal renal tubules. Fifty-five percent of the cases were in patients treated for idiopathic thrombocytopenic purpura (ITP), and less than 5% involved patients with primary immunodeficiency.<sup>55</sup> This complication may relate to the higher doses of IVIG used in ITP. The majority of the cases were treated successfully with conservative treatment, but deaths were reported in 17 patients who had serious underlying conditions. Reports suggest that IVIG products using sucrose as a stabilizer may carry a greater risk for this renal complication. Because of this, the infusion rate for sucrose-containing IVIG should not exceed 3 mg sucrose/kg/minute. Risk factors for this adverse reaction include preexisting renal insufficiency, diabetes mellitus, dehydration, age greater than 65, sepsis, paraproteinemia and concomitant use of nephrotoxic agents. For patients at increased risk, monitoring blood urea nitrogen and creatinine before starting the treatment and periodically thereafter is necessary. If renal function deteriorates, the product

### BOX 15-3 ADVERSE EFFECTS OF IVIG ADMINISTRATION

#### COMMON

- Chills
- Headache
- Backache
- Myalgia
- Malaise/fatigue
- Fever
- Pruritus
- Rash, flushing
- Nausea, vomiting
- Tingling
- Hypo- or hypertension
- Fluid overload

#### RELATIVELY UNCOMMON (MULTIPLE REPORTS)

- Chest pain or tightness
- Dyspnea
- Severe headaches
- Aseptic meningitis
- Renal failure

#### RARE (ISOLATED REPORTS)

- Anaphylaxis
- Arthritis
- Thrombosis/cerebral infarction
- Myocardial infarction
- Acute encephalopathy
- Cardiac rhythm abnormalities
- Coagulopathy
- Hemolysis
- Neutropenia
- Alopecia
- Uveitis
- Noninfectious hepatitis
- Hypothermia
- Lymphocytic pleural effusion

#### POTENTIAL (NO REPORTS)

- Prion disease
- HIV infections
- Parvovirus B19

should be changed to a nonsucrose-containing IVIG or to SCIG.

### Anaphylactic Reactions

Anaphylactic reactions to IVIG infusions are relatively rare.<sup>49</sup> IgE and IgG antibodies to IgA have been reported to cause severe reactions in IgA-deficient patients receiving intravenous gammaglobulin preparations.<sup>7,56,57</sup> Because of these concerns, the prescribing information for current gammaglobulin products includes either a precaution or contraindication to usage in IgA-deficient patients. Several studies have shown that these patients that have reacted to conventional IVIG preparations could then go on to tolerate IVIG preparations containing very low concentrations of contaminating IgA.<sup>7,58</sup> However, other studies have described patients with anti-IgA antibodies tolerating IgA-containing IVIG preparations without reaction.<sup>59,60</sup> Therefore the clinical significance of anti-IgA antibodies, and the role that these antibodies play in cases of anaphylaxis to IVIG products, remains controversial.

### Thromboembolic Events

All human immune globulin products currently licensed in the USA carry an FDA warning of the risk of thrombosis with this class of products.<sup>61</sup> Local thromboses at infusion sites, deep vein thrombosis, pulmonary embolism, myocardial infarctions, transient ischemic attacks and stroke have all been reported following IVIG infusion.<sup>62–65</sup>

Risk factors for the development of IVIG-related thrombosis include advanced age, prolonged immobilization, hypercoagulable conditions, history of thrombosis, supplemental estrogens, indwelling central vascular catheters, hyperviscosity and cardiovascular risk factors.<sup>61,62,65,66</sup>

It has been suspected that these thrombotic complications were due to platelet activation and/or increased serum viscosity in patients receiving large doses of IVIG.<sup>67–69</sup> Recently, one IVIG product's increased risk for thromboembolic events has been shown to be due to high levels of activated Factor XI (FXIa).<sup>70</sup> Concerns over FXIa-related thrombosis have led to changes in manufacturing techniques, removal of Factor XI/XIa using an adsorbent during the manufacturing process, and use of the thrombin generation assay to monitor procoagulant activity of immunoglobulin products.<sup>70</sup>

### Hemolytic Adverse Reactions

Because IVIG preparations are prepared from a large number of donors, IgG isohemagglutinins (antibodies against A/B blood group antigens) are present in these preparations. In non-O blood type recipients, anti-A and anti-B antibodies from the IVIG may react with red blood cells to cause asymptomatic Coombs positivity, or less commonly clinically significant hemolytic reactions, especially in those receiving high cumulative doses of immune globulin.<sup>71–73</sup> Clinically significant hemolysis is very rare in licensing studies of IVIG for primary immune deficiency, using doses of 400–800 mg/kg. Currently all immunoglobulin products licensed in the EU and USA are required to contain anti-A and anti-B titers that are less than or equal to 1 : 64 by the direct agglutination test.<sup>74</sup> Despite this, current products meeting these regulations are still implicated in cases of hemolysis, and strategies to address this issue of hemolysis are being pursued by the FDA.<sup>74</sup> Some manufacturers are instituting steps such as the use of adsorbents to lower titers of anti-A and anti-B.<sup>75</sup>

### Infectious Complications

Hepatitis C virus (HCV) infection in patients receiving IVIG products was initially reported in experimental lots in Europe and the USA. HCV infection usually occurred in clusters associated with contaminated lots<sup>76,77</sup> and specific manufacturing procedures. The clinical course of HCV infection in patients with immune deficiency is not well defined. Routine screening of plasma donors for hepatitis C RNA by reverse transcriptase polymerase chain reaction (RT-PCR) and the addition of a viral inactivation process in the final manufacturing step, e.g. treatment with solvent/detergent and/or pasteurization, has drastically reduced the risk of transmission of hepatitis C and other viruses. In addition to these approaches in donor and plasma screening and testing, new innovative steps have been incorporated during the manufacturing process that include viral inactivation and viral removal stages. Some of the more common processes include solvent-detergent treatment of the final IVIG product to destroy potential lipid-envelope viruses, incubation at low pH, pasteurization, caprylate treatment and viral removal steps with depth filtration and nanofiltration. In aggregate, all these steps lead to a potential removal of 10–20 log<sub>10</sub> reduction values (depending on the virus).<sup>78,79</sup> Thus, today's IVIG products are considered safe from a number of potential viral pathogens that were of concern in the early and mid 1990s. However, one potential group of pathogens that are still of potential concern are prions, which can cause transmissible spongiform encephalopathy, a fatal degenerative disease of the brain.<sup>80</sup> IVIG manufacturers have recognized prion-mediated disease as a potential problem and have initiated testing and IVIG purification and treatment steps (e.g. nanofiltration) to address this issue.<sup>81</sup>

### Reactions to Subcutaneous Immunoglobulin

In general, the SCIG route has been remarkably free from severe systemic reactions.<sup>25,26,41,82</sup> In contrast, the majority of patients do experience local site reactions at some point during SCIG therapy, with symptoms of swelling, soreness, warmth, redness, induration, pruritus and/or bruising. Most of these local reactions last for less than 48 hours, and the severity and frequency of local reactions decrease as the patient continues SCIG therapy.<sup>83–85</sup>

## IVIG as an Immune Modulating Agent in Patients with Autoimmune or Inflammatory Disorders

Since the first report by Imbach and colleagues<sup>86</sup> on the use of IVIG in childhood ITP, IVIG has been used for the treatment of a variety of inflammatory and autoimmune disorders.<sup>87</sup> A number of mechanisms have been postulated for the immunomodulatory effects of IVIG.<sup>88</sup> The mechanisms of action of Ig therapy can be broadly examined as follows: effects of Ig on Fc receptors, effects on the innate immune system, and effects on the adaptive immune system (Figure 15-1).

### IMMUNE MODULATION OF FC RECEPTORS

In ITP the platelet counts rise rapidly following the administration of IVIG 1–2 g/kg.<sup>89</sup> The mechanism for platelet destruction is from FcγR-mediated phagocytic clearance of autoantibody-opsonized platelets in the spleen and liver.<sup>90</sup> Fehr

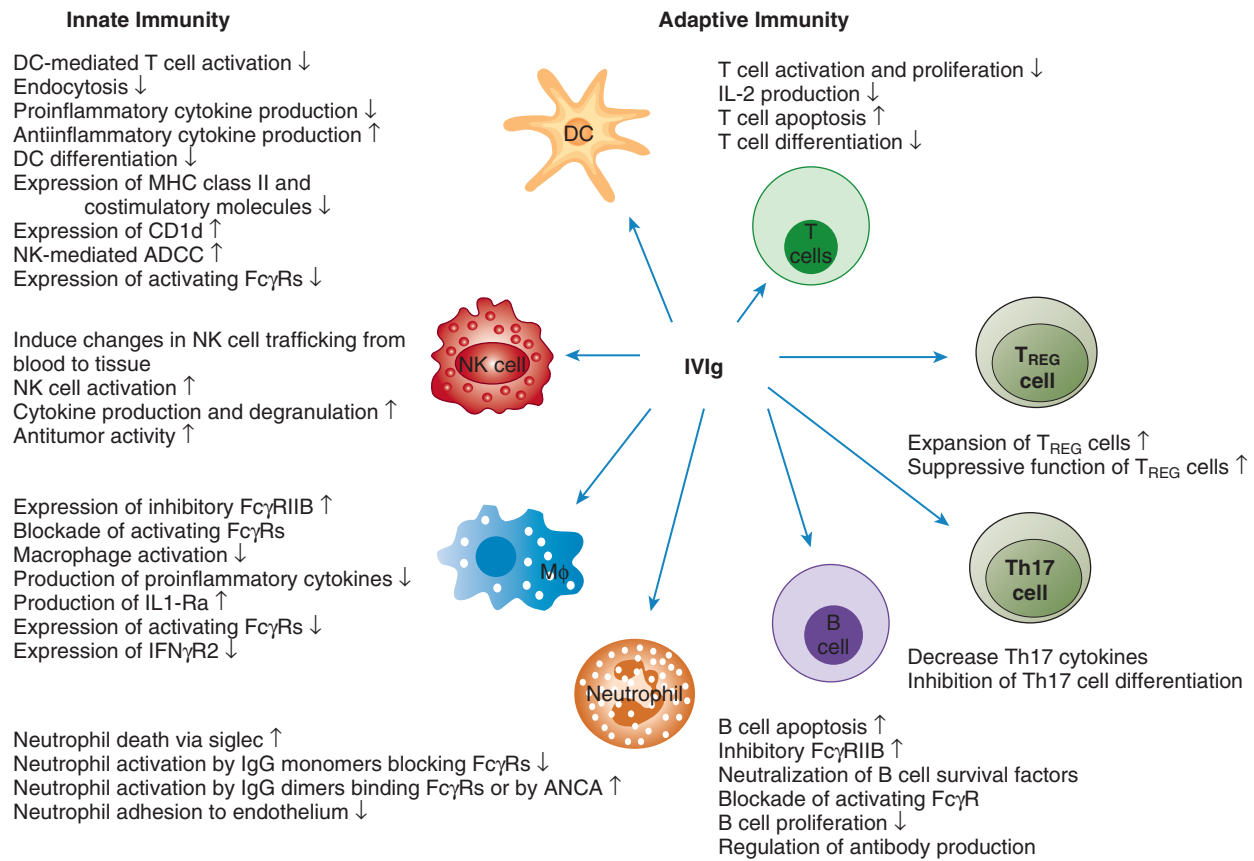

**Figure 15-1** Mechanisms of action of IVIG on the immune modulation of various components of the innate and adaptive immune systems. DC, Dendritic cell; Mφ, macrophage; NK, natural killer; MHC, major histocompatibility complex; ADCC, antibody dependent cellular cytotoxicity; ANCA, antineutrophil cytoplasmic antibody *siglec*–sialic acid-binding immunoglobulin-type lectin. (Adapted from *Tha-In T, et al. M Trends Immunol 2008;29(12):608–15*; and *Ballow M. The IgG molecule as a biological immune response modifier: mechanisms of action of intravenous immune serum globulin in autoimmune and inflammatory disorders. J Allergy Clin Immunol 127(2):315–23*.)

and colleagues<sup>91</sup> and Bussel<sup>92</sup> suggested that the rapid responses following IVIG treatment in ITP were caused by a blockade of the reticuloendothelial system (RES) by saturating these Fcγ receptors with the exogenous IgG. The observations by Debre and colleagues<sup>93</sup> when children with acute ITP were treated with intravenous Fcγ fragments from a preparation of IVIG supports the hypothesis that Fcγ receptor blockade is an important mechanism of action of IVIG in ITP, although other immune regulatory mechanisms are present.

Another mechanism that involves a specialized Fc receptor is the proposed antiinflammatory effect of IVIG on the clearance of pathogenic autoantibodies by competing with autoantibodies for the neonatal Fc receptor (FcRn).<sup>12</sup> FcRn protects IgG from degradation and is critical for its long half-life in the serum.<sup>94</sup> In mouse models of bullous pemphigoid and arthritis, IVIG treatment results in a reduction in pathogenic antibodies to levels beneath the disease-causing threshold, and this effect is attenuated in FcRn-deficient mice.<sup>95,96</sup> Hansen and Balthasar<sup>97</sup> reported that high-dose IVIG in a rat model of immune thrombocytopenia enhanced the clearance of antiplatelet antibodies by the saturation of the FcRn receptor for IgG. The importance of this mechanism in human diseases is difficult to measure but in an FcRn-deficient rat model it has been estimated that this mechanism may account for approximately 50% of the immunomodulating effects of IVIG in ITP.<sup>97</sup>

Macrophages, B cells and a subpopulation of T cells express a low-affinity inhibitory Fcγ receptor (FcγRIIB).<sup>98,99</sup> This receptor provides an inhibitory signal to cells through a pathway

mediated by an immunoregulatory tyrosine-based inhibition motif, e.g. ITIM. Similar inhibitory Fcγ receptors are present on basophils and mast cells. Samuelsson and colleagues<sup>100</sup> investigated a murine model of immune thrombocytopenia. They found that the protective effects of IVIG required the inhibitory Fcγ receptor, e.g. FcγRIIB, since either disruption of the receptor or blocking with a monoclonal antibody reversed the therapeutic effects. In addition, IVIG therapy results in the up-regulation of the inhibitory FcγRIIB on effector macrophages.<sup>100,101</sup> The observations on the effects of IVIG in patients with steroid-dependent asthma<sup>102,103</sup> may be related to similar FcγRIIB regulatory receptors on basophils and mast cells.

Studies by Kaneko and colleagues<sup>101</sup> showed that a component moiety of the IVIG molecule responsible for its antiinflammatory activity is the part of the IgG molecule that contains a sialylation site on the glycan linked to asparagine at position 297 on the Fc fragment (only 1–2% of the total IgG in IVIG). Desialylation of the sialic acid residues with neuraminidase was demonstrated to blunt the protective effect of an IVIG preparation in a mouse model of rheumatoid arthritis. In the same K/BxN arthritis model, sialic acid-enriched fractions of IVIG with the 2,6-sialylated linkage at Asn297 on the Fc portion showed a 10-fold increase in protection against immune-mediated arthritis. Anthony and colleagues<sup>104,105</sup> have demonstrated that greatly reduced doses of a recombinant, sialylated Fc fragment can completely recapitulate the antiinflammatory effects of IVIG in this same mouse model. These investigators have shown that the action of sialylated Fc in the rheumatoid arthritis

mouse model is mediated through the interaction of sialylated Fc with the SIGN-R1 receptor on macrophages.<sup>105</sup> The authors propose that the interaction between sialylated Fc and SIGN-R1 (CD209) produces an antiinflammatory state that results in an up-regulation of inhibitory FcγRIIB receptors on effector macrophages, making these cells more resistant to triggering by immune complexes. They suggest that DC-SIGN, the human ortholog of SIGN-R1, may have a comparable role in the antiinflammatory effects of IgG Fcs in human disease. More recently, Anthony et al<sup>106</sup> reported that the modulating effect of sialylated-rich IgG binding to SIGN R1 on marginal zone macrophages in their K/BxN arthritis mouse model was mediated by the production of IL-33 by dendritic cells, which, in turn, induced the expansion of IL-4 producing basophils that promote the increased expression of FcγRIIB receptors on effector macrophages. These new findings may explain some of the observed effects of IVIG and have the potential to tie together several of the proposed antiinflammatory actions into a more cohesive model for the mechanism(s) of IVIG activity in many autoimmune diseases.<sup>107</sup>

### EFFECTS OF IMMUNOGLOBULIN ON COMPONENTS OF THE INNATE IMMUNE SYSTEM

IVIG binds to activated C3b and C4b and prevents the tissue deposition of these activated complement proteins.<sup>108</sup> Several diseases and animal models have been reported in which inhibition of complement has been suggested as the mechanism of IVIG's antiinflammatory activity. Frank and his co-workers,<sup>109</sup> using an animal model of Forsman shock, demonstrated that high-dose IVIG prevented the death of guinea pigs by preventing activated C3 and C4 fragments from binding to target cells, resulting in the modulation of acute complement-dependent tissue injury. Basta and colleagues<sup>110</sup> showed that IVIG not only inhibited the uptake of C3 fragments onto antibody-sensitized cells, but also C4, an early complement component.

Dermatomyositis (DM) provides an example of the effects of IVIG on complement-mediated damage in an autoimmune disease. This autoimmune disease is characterized by the subacute onset of muscle weakness, affecting predominantly the proximal muscle groups, is often accompanied or preceded by a characteristic skin rash, and is associated with circulating autoantibodies to endothelial cells and histidyl-tRNA synthetase (Jo-1).<sup>111,112</sup> A humoral immune process directed against the intramuscular capillaries characterizes the immunopathogenesis of DM. This process leads to a complement-mediated endomysial microangiopathy with deposition of the membrane attack complex (MAC) consisting of activated complement components C5b-9 on the intramuscular capillaries.<sup>112</sup> The endomysial capillary damage as a result of MAC deposition leads to microinfarcts within the muscle fascicles, muscle ischemia, inflammation and eventually perifascicular atrophy.<sup>113</sup> The expression of ICAM-1 is increased on the endomysial blood vessels and muscle cells, which further facilitates the infiltration of inflammatory cells, mainly CD4<sup>+</sup> T cells and some B cells.<sup>113,114</sup> Dalakas and colleagues<sup>112,115</sup> reported that the muscle biopsies of patients improve after IVIG therapy and histologically the MAC deposits disappear from the endomysial capillaries along with a decrease in ICAM-1 expression in muscle tissues.<sup>112,116</sup>

The acute vaso-occlusive crisis of sickle cell disease (SCD) is another disease in which IVIG may modulate adhesion

molecules. In SCD, abnormal sickle red blood cells (RBCs) have an increased propensity to adhere to each other and to vascular endothelial cells, resulting in vascular occlusion. Sickled RBCs have also been shown to adhere to other blood cells, including leukocytes. Chang and colleagues<sup>117</sup> investigated the effect of IVIG on a mouse model of sickle cell acute vaso-occlusive crisis, in which the adhesion of sickle RBCs to leukocytes is known to cause the vaso-occlusive pathology. In this model, high-dose IVIG given after the onset of a crisis resulted in improved blood flow and prolonged survival. The investigators demonstrated that the mechanism of IVIG in this model was a rapid reduction in neutrophil adhesion to vascular endothelium and decreased interaction between RBCs and leukocytes.

### EFFECTS OF IMMUNOGLOBULIN THERAPY ON COMPONENTS OF THE ADAPTIVE IMMUNE SYSTEM

Viard and colleagues<sup>118</sup> reported that IVIG could inhibit the apoptotic process, i.e. programmed cell death, in patients with toxic epidermal necrolysis (TEN or Lyell's syndrome), a severe drug-induced bullous skin reaction. In *in vitro* studies IVIG was demonstrated to protect the keratinocytes from apoptosis by blocking the effects of FasL on the Fas receptor. These investigators also determined that the depletion of anti-Fas antibodies from IVIG abrogated the ability of IVIG to inhibit FasL-mediated apoptosis. In an open, uncontrolled trial of IVIG (0.2–0.75 g/kg/day for 4 consecutive days) in 10 patients with TEN, skin progression was halted within 1 to 2 days and was followed by rapid skin healing and a favorable outcome. This immune-modulating effect of IVIG in patients with TEN represents another unique mechanism by which IVIG can modify the disease process, and may prove to be useful in other Fas-mediated inflammatory or autoimmune diseases.

While IVIG has been shown to have suppressive effects on effector T cells,<sup>119,120</sup> it has been shown to expand and enhance the function of Foxp3<sup>+</sup> regulatory T cells (T<sub>REGS</sub>). In a mouse model of multiple sclerosis, the protective effect of IVIG was lost in mice that were depleted of T<sub>REGS</sub>.<sup>121</sup> In patients with Kawasaki disease and Guillain-Barré syndrome, clinical improvement with IVIG therapy correlated with increased T<sub>REG</sub> number and function.<sup>122</sup> De Groot and colleagues<sup>123</sup> proposed that IVIG has a positive effect on T<sub>REGS</sub> because of the presence of T cell epitopes in the Fab and Fc fragments which, when presented by antigen-presenting cells, specifically activate CD4<sup>+</sup>CD25<sup>+</sup>Foxp3<sup>+</sup> T<sub>REGS</sub>, and that this expansion of T<sub>REGS</sub> mediates the immunomodulatory effects of IVIG. Tjon et al<sup>124</sup> reported that high-dose, but not low-dose, IVIG treatment in patients with immunodeficiency and autoimmune disease enhanced the activation of circulating T<sub>REG</sub> cells, but the numbers of circulating T<sub>REG</sub> cells remained unchanged. Kaufman et al have extensively studied the effects of IVIG therapy in an ovalbumin-sensitized mouse model of asthma. IVIG markedly attenuated lung inflammation and decreased bronchial hyperresponsiveness to methacholine.<sup>125</sup> IL-13 and TNF-α levels were diminished, Delta-4 (part of the Notch pathway that induces Th1 cells) expression increased, while Jagged-1 (part of the Notch pathway that induces Th2 cells) expression and GATA-3 mRNA decreased, suggesting that Th2 responses were suppressed. The draining pulmonary lymph nodes of IVIG-treated mice showed a significant increase in CD4<sup>+</sup>CD25<sup>+</sup>Foxp3<sup>+</sup> regulatory cells, and IVIG-primed dendritic



**BOX 15-4 THERAPEUTIC PRINCIPLES OF IVIG TREATMENT IN PATIENTS WITH PRIMARY IMMUNE DEFICIENCY**

- Initial dosage: 400–600 mg/kg every 4 weeks for replacement therapy:
  - some patients may benefit from trough levels of 700–900 mg/dL
  - adjust the dose and/or dosing interval depending on clinical response
  - record manufacturer, lot number and dose with each infusion
- Equilibration takes several months even when dosage changes made:
  - check trough levels if patient continues to have infections or prior to dose change
    - may be useful to determine adherence in patients on SCIG
  - treat the patient and not the 'numbers', e.g. trough level
- For patients with systemic adverse effects or poor venous access, the subcutaneous route may be a better option.
- Ig replacement therapy is indicated as continuous replacement therapy for primary immunodeficiency. Treatment should not be interrupted once a definitive diagnosis has been established.
- Site of care. The decision to infuse IVIG in a hospital, hospital outpatient, community office or home-based setting must be based upon clinical characteristics of the patient.
- IVIG is not a generic drug and IVIG products are not interchangeable. A specific IVIG product needs to be matched to patient characteristics to ensure patient safety. A change of IVIG product should occur only with the active participation of the prescribing physician.

**MONITOR**

- Complete blood count with differential; liver and renal function tests every 6–12 months
- Nucleotide testing for viral pathogens, e.g. hepatitis C, when indicated
- Pulmonary function testing; diffusion capacity testing as indicated; chest x-ray, high-resolution chest tomography (initially if there is a history of lung disease and thereafter as indicated – may enhance patient's risk of malignancy)

Data from the Primary Immunodeficiency Committee of the American Academy of Allergy, Asthma & Immunology. Source: [www.aaaai.org/practice-resources/practice-tools/ivig-toolkit.aspx](http://www.aaaai.org/practice-resources/practice-tools/ivig-toolkit.aspx) (accessed Dec 27, 2013).

cells on adoptive transfer to ovalbumin-sensitized and -challenged mice abrogated airway hyperresponsiveness and induced T<sub>REG</sub> cells.<sup>126</sup> In this model system, Massoud et al reported that sialylated IgG bound to a novel C-type lectin receptor, i.e. dendritic cell immunoreceptor (DCIR), induced T<sub>REG</sub> cells. Thus, a number of studies recently have demonstrated the importance of the induction of Foxp3<sup>+</sup> T<sub>REG</sub> cells by IVIG in modulating the autoimmune/antiinflammatory process, while immunoglobulin therapy may down-regulate the TH-17 pathway.<sup>127</sup>

**Conclusion**

Immunoglobulin replacement is the mainstay of treatment for patients with primary humoral immune deficiency. The goal of the treatment is to provide a broad spectrum of antibodies to prevent infections and chronic complications. The usual dose is 400–600 mg/kg/month but this may vary individually and higher doses may be required during active infection. A serum trough level above 500 mg/dL has been shown to be effective in the prevention of severe infections. However, recent studies

have suggested that even higher doses and achieving IgG trough levels of 700–1,000 mg/dL may be desirable.<sup>21,22</sup> Recently, SCIG has gained acceptance as an alternative route for the administration of replacement therapy in patients with immune deficiency. Generally, IVIG replacement therapy is considered safe in the majority of patients. Side-effects are usually mild and treatable by premedication. Improvements in good manufacturing practices, closer screening of plasma donors, testing of the source plasma with sensitive nucleic acid assays, e.g. PCR, and additional viral inactivation steps have made IVIG a better and safer plasma-derived product. The majority of the utilization of IVIG therapy is in patients with autoimmune disorders. The use of IVIG in these patient groups has not only led to a new treatment modality but has enhanced our understanding of the disease pathogenesis and the mechanisms by which IVIG may modulate the immune and inflammatory processes (Box 15-4).

The complete reference list can be found on the companion Expert Consult website at <http://www.expertconsult.inkling.com>.

**KEY REFERENCES**

- Rachid R, Bonilla FA. The role of anti-IgA antibodies in causing adverse reactions to gamma globulin infusion in immunodeficient patients: a comprehensive review of the literature. *J Allergy Clin Immunol* 2012;129:628–34.
- Orange JS, Grossman WJ, Navickis RJ, Wilkes MM. Impact of trough IgG on pneumonia incidence in primary immunodeficiency: a meta-analysis of clinical studies. *Clin Immunol* 2010;137:21–30.
- Bonagura VR, Marchlewski R, Cox A, Rosenthal DW. Biologic IgG level in primary immunodeficiency disease: the IgG level that protects against recurrent infection. *J Allergy Clin Immunol* 2008;122:120–12.
- Abolhassani H, Sadaghiani MS, Aghamohammadi A, Ochs HD, Rezaei N. Home-based subcutaneous immunoglobulin versus hospital-based intravenous immunoglobulin in treatment of primary antibody deficiencies: systematic review and meta analysis. *J Clin Immunol* 2012;32:1180–92.
- Berger M, Rojavin M, Kiessling P, Zenker O. Pharmacokinetics of subcutaneous immunoglobulin and their use in dosing of replacement therapy in patients with primary immunodeficiencies. *Clin Immunol* 2011;139:133–41.
- Brennan VM, Salome-Bentley NJ, Chapel HM. Prospective audit of adverse reactions occurring in 459 primary antibody-deficient patients receiving intravenous immunoglobulin. *Clin Exp Immunol* 2003;133:247–51.
- Caress JB, Hobson-Webb L, Passmore LV, Finkbiner AP, Cartwright MS. Case-control study of thromboembolic events associated with IV immunoglobulin. *J Neurol* 2009;256:339–42.
- Ballow M. Safety of IGIV therapy and infusion-related adverse events. *Immunol Res* 2007;38:122–32.
- Orange JS, Hossny EM, Weiler CR, Ballow M, Berger M, Bonilla FA, et al. Use of intravenous immunoglobulin in human disease: a review of evidence by members of the Primary Immunodeficiency Committee of the American Academy of Allergy, Asthma and Immunology. *J Allergy Clin Immunol* 2006;117:S25–53.
- Samuelsson A, Towers TL, Ravetch JV. Anti-inflammatory activity of IVIG mediated through the inhibitory Fc receptor. *Science* 2001;291:484–6.

## REFERENCES

- Cohn EJ, Luetscher JA Jr, Oncley JL, Armstrong SH Jr, Davis BD. Preparation and properties of serum and plasma proteins. III. Size and charge of proteins separating upon equilibration across membranes with ethanol-water mixtures of controlled pH, ionic strength and temperature. *J Am Chem Soc* 1940;62:3396–400.
- Bruton OC. Agammaglobulinemia. *Pediatrics* 1952;9:722–8.
- Ballow M. Primary immunodeficiency disorders: antibody deficiency. *J Allergy Clin Immunol* 2002;109:581–91.
- Cohn EJ. The history of plasma fractionation. In: Andrus EC, Bronk DW, Carden GA Jr, et al, editors. *Advances in military medicine*, vol. 1. Boston: Little, Brown; 1948. p. 364–443.
- Eibl MM, Wedgwood RJ. Intravenous immunoglobulin: a review. *Immunodef Rev* 1989;1(Suppl.):1–42.
- Mikolajczyk MG, Concepcion NF, Wang T, Frazier D, Golding B, Frasch CE, et al. Characterization of antibodies to capsular polysaccharide antigens of *Haemophilus influenzae* type b and *Streptococcus pneumoniae* in human immune globulin intravenous preparations. *Clin Diagn Lab Immunol* 2004;11:1158–64.
- Burks A, Sampson H, Buckley R. Anaphylactic reactions after gammaglobulin administration in patients with hypogammaglobulinemia. Detection of IgE antibodies to IgA. *N Engl J Med* 1986;314:560.
- Rachid R, Bonilla FA. The role of anti-IgA antibodies in causing adverse reactions to gamma globulin infusion in immunodeficient patients: a comprehensive review of the literature. *J Allergy Clin Immunol* 2012;129:628–34.
- Fischer SH, Ochs HD, Wedgwood RJ, Skvaril F, Morell A, Hill HR, et al. Survival of antigen-specific antibody following administration of intravenous immunoglobulin in patients with primary immunodeficiency diseases. *Monogr Allergy* 1988;23:225–35.
- Mankariou S, Lee M, Fischer S, Pyun KH, Ochs HD, Oxelius VA, et al. The half-lives of IgG subclasses and specific antibodies in patients with primary immunodeficiency who are receiving intravenously administered immunoglobulin. *J Lab Clin Med* 1988;112:634–40.
- Waldmann TA, Strober W. Metabolism of immunoglobulins. *Prog Allergy* 1969;13:1–110.
- Yu Z, Lennon VA. Mechanism of intravenous immune globulin therapy in antibody-mediated autoimmune diseases. *N Engl J Med* 1999;340:227–8.
- Ochs HD, Fischer SH, Wedgwood RJ, Wara DW, Cowan MJ, Ammann AJ, et al. Comparison of high-dose and low-dose intravenous immunoglobulin therapy in patients with primary immunodeficiency diseases. *Am J Med* 1984;76:78–82.
- Stiehm ER. Immunodeficiency disorders: general considerations. In: Stiehm ER, editor. *Immunologic disorders in infants and children*. ed 4. Philadelphia: Saunders; 1996. p. 201–52.
- Bernatowska E, Madaliński K, Janowicz W, Weremowicz R, Gutkowski P, Wolf HM, et al. Results of a prospective controlled two-dose crossover study with intravenous immunoglobulin and comparison (retrospective) with plasma treatment. *Clin Immunol Immunopathol* 1987;43:153–62.
- Roifman CM, Levison H, Gelfand EW. High-dose versus low-dose intravenous immunoglobulin in hypogammaglobulinemia and chronic lung disease. *Lancet* 1987;i:1075–7.
- Liese JG, Wintergerst U, Tympner KD, Belohradsky BH. High- vs low-dose immunoglobulin therapy in the long-term treatment of x-linked agammaglobulinemia. *AJDC* 1992;146:335–9.
- Eijkhout HW, van Der Meer JW, Kallenberg CG, Weening RS, van Dissel JT, Sanders LA. The effect of two different dosages of intravenous immunoglobulin on the incidence of recurrent infections in patients with primary hypogammaglobulinemia: a randomized, double-blind, multicenter crossover trial. *Ann Intern Med* 2001;135:165–74.
- Kainulainen L, Varpula M, Liippo K, Svedstrom E, Nikoskelainen J, Ruuskanen O. Pulmonary abnormalities in patients with primary hypogammaglobulinemia. *J Allergy Clin Immunol* 1999;104:1031–6.
- Quartier P, Debre M, DeBlie J, de Sauverze R, Sayegh N, Jabado N. Early and prolonged intravenous immunoglobulin replacement therapy in childhood agammaglobulinemia: a retrospective survey of 31 patients. *J Pediatr* 1999;134:589–96.
- Orange JS, Grossman WJ, Navickis RJ, Wilkes MM. Impact of trough IgG on pneumonia incidence in primary immunodeficiency: a meta-analysis of clinical studies. *Clin Immunol* 2010;137:21–30.
- Bonagura VR, Marchlewski R, Cox A, Rosenthal DW. Biologic IgG level in primary immunodeficiency disease: the IgG level that protects against recurrent infection. *J Allergy Clin Immunol* 2008;122:210–12.
- Lucas M, Lee M, Lortan J, Lopez-Granados E, Misbah S, Chapel H. Infection outcomes in patients with common variable immunodeficiency disorders: relationship to immunoglobulin therapy over 22 years. *J Allergy Clin Immunol* 2010;125:1354–60 e4.
- Ammann AJ, Ashman RF, Buckley RH, Hardie WR, Krantmann HJ, Nelson J, et al. Use of intravenous gammaglobulin in antibody immunodeficiency: results of a multicenter controlled trial. *Clin Immunol Immunopathol* 1982;22:60–7.
- GAMMAGARD LIQUID. Immune Globulin Infusion (Human), 10% [package insert]. Westlake Village, CA; Baxter; Revised September, 2013.
- GAMUNEX®-C. Immune Globulin Injection (Human) 10% Caprylate/Chromatography Purified [package insert]. Research Triangle Park, NC; Grifols; Revised September, 2013.
- Octagam. Immune Globulin Intravenous (Human) 5% Liquid Preparation [package insert]. Hoboken, NJ; Octapharma; Revised September, 2013.
- BIVIGAM. Immune Globulin Intravenous (Human), 10% Liquid [package insert]. Boca Raton, FL; Biotest Pharmaceuticals; Revised September, 2013.
- Privigen. Immune Globulin Intravenous (Human), 10% Liquid [package insert]. Kankakee, IL; CSL Behring; Revised September, 2013.
- Berger M, Cupps TR, Fauci AS. Immunoglobulin replacement therapy by slow subcutaneous infusion. *Ann Intern Med* 1980;93:55–66.
- Bayston K, Leahy MF, McCreanor JD, Gebbie T. Subcutaneous gammaglobulin: effective management of hypogammaglobulinemia. *N Z Med J* 1985;98:652.
- Leahy MF. Subcutaneous immunoglobulin home treatment in hypogammaglobulinemia. *Lancet* 1986;2:48.
- Gardulf A, Hammarstrom L, Smith CIE. Home treatment of hypogammaglobulinemia with subcutaneous gammaglobulin by rapid infusion. *Lancet* 1991;338:162–6.
- Abrahamsen TG, Sandersen H, Bustnes A. Home therapy with subcutaneous immunoglobulin infusions in children with congenital immunodeficiencies. *Pediatrics* 1996;98:1127–31.
- Thomas MJ, Brennan VM, Chapel HH. Rapid subcutaneous immunoglobulin infusions in children. *Lancet* 1993;342:1432–3.
- Gaspar J, Gerritsen B, Jones A. Immunoglobulin replacement treatment by rapid subcutaneous infusion. *Arch Dis Child* 1998;79:48–51.
- Abolhassani H, Sadaghiani MS, Aghamohammadi A, Ochs HD, Rezaei N. Home-based subcutaneous immunoglobulin versus hospital-based intravenous immunoglobulin in treatment of primary antibody deficiencies: systematic review and meta analysis. *J Clin Immunol* 2012;32:1180–92.
- Bonilla FA. Pharmacokinetics of immunoglobulin administered via intravenous or subcutaneous routes. *Immunol Allergy Clin North Am* 2008;28:803–19, ix.
- Waniewski J, Gardulf A, Hammarstrom L. Bioavailability of gammaglobulin after subcutaneous infusions in patients with common variable immunodeficiency. *J Clin Immunol* 1994;14:90–7.
- Berger M, Rojavin M, Kiessling P, Zenker O. Pharmacokinetics of subcutaneous immunoglobulin and their use in dosing of replacement therapy in patients with primary immunodeficiencies. *Clin Immunol* 2011;139:133–41.
- Hizentra®. Immune Globulin Subcutaneous (Human), 20% Liquid [package insert]. Kankakee, IL; CSL Behring; Revised September, 2013.
- Berger M, Jolles S, Orange JS, Sleasman JW. Bioavailability of IgG administered by the subcutaneous route. *J Clin Immunol* 2013;33:984–90.
- Kittner JM, Grimbacher B, Wulff W, Jager B, Schmidt RE. Patients' attitude to subcutaneous immunoglobulin substitution as home therapy. *J Clin Immunol* 2006;26:400–5.
- Hoffmann F, Grimbacher B, Thiel J, Peter HH, Belohradsky BH. Vivaglobin Study G. Home-based subcutaneous immunoglobulin G replacement therapy under real-life conditions in children and adults with antibody deficiency. *Eur J Med Res* 2010;15:238–45.
- Haddad E, Berger M, Wang EC, Jones CA, Bexon M, Baggish JS. Higher doses of subcutaneous IgG reduce resource utilization in patients with primary immunodeficiency. *J Clin Immunol* 2012;32:281–9.
- Radinsky S, Bonagura VR. Subcutaneous immunoglobulin infusion as an alternative to intravenous immunoglobulin. *J Allergy Clin Immunol* 2003;112:630–3.
- Lederman H, Roifman T, Lavi S, Gelfand EW. Corticosteroids for prevention of adverse

- reactions to intravenous immune serum globulin infusions in hypogammaglobulinemic patients. *Am J Med* 1986;81:443–6.
48. Camussi G, Aglietta M, Coda R, Bussolino F, Piacibello W, Tetta C. Release of platelet activating factor (PAF) and histamine. II. The cellular origin of human PAF monocytes, polymorphonuclear neutrophils and basophils. *Immunology* 1981;42:191–9.
  49. Brennan VM, Salome-Bentley NJ, Chapel HM. Prospective audit of adverse reactions occurring in 459 primary antibody-deficient patients receiving intravenous immunoglobulin. *Clin Exp Immunol* 2003;133:247–51.
  50. Robertson DM, Hosking CS. Use of methylprednisolone as prophylaxis for immediate adverse infusion reactions in hypogammaglobulinaemic patients receiving intravenous immunoglobulin: a controlled trial. *Aust Paediatr J* 1988;24:174–7.
  51. Sekul EA, Cupler EJ, Dalakas MC. Aseptic meningitis associated with high-dose intravenous immunoglobulin therapy: frequency and risk factors. *Ann Intern Med* 1994;121:259–62.
  52. Scribner CL, Kapit RM, Phillips ET, Rickles NM. Aseptic meningitis and intravenous immunoglobulin therapy. *Ann Intern Med* 1994;121:305–6.
  53. Kato E, Shindo S, Eto Y, Hashimoto N, Yamamoto M, Sakata Y, et al. Administration of immune globulin associated with aseptic meningitis. *JAMA* 1988;259:3269–71.
  54. Brannagan TH, Nagle KJ, Lange DJ, Rowland LP. Complications of intravenous immune globulin treatment in neurologic disease. *Neurology* 1996;47:674–7.
  55. Centers for Disease Control and Prevention. Renal insufficiency and failure associated with immune globulin intravenous therapy – United States, 1986–1998. *MMWR Morb Mortal Wkly Rep* 1999;48:518–21.
  56. Cunningham-Rundles C. Intravenous immune serum globulin in immunodeficiency. *Vox Sang* 1985;49(Suppl. 1):8–14.
  57. Vyas GN, Perkins HA, Fudenberg HH. Anaphylactoid transfusion reactions associated with anti-IgA. *Lancet* 1968;2:312–15.
  58. Cunningham-Rundles C, Zhou Z, Mankariou S, Courter S. Long-term use of IgA-depleted intravenous immunoglobulin in immunodeficient subjects with anti-IgA antibodies. *J Clin Immunol* 1993;13:272–8.
  59. Ferreira A, Garcia Rodriguez MC, Fontan G. Follow-up of anti-IgA antibodies in primary immunodeficient patients treated with gamma-globulin. *Vox Sang* 1989;56:218–22.
  60. de Albuquerque Campos R, Sato MN, da Silva Duarte AJ. IgG Anti-IgA subclasses in common variable immunodeficiency and association with severe adverse reactions to intravenous immunoglobulin therapy. *J Clin Immunol* 2000;20:77–82.
  61. US Food and Drug Administration. FDA Safety Communication: new boxed warning for thrombosis related to human immune globulin products; November 14, 2013. <http://www.fda.gov/BiologicsBloodVaccines/Safety-Availability/ucm375096.htm> – Summary of Safety Issue (accessed June 2, 2014).
  62. Caress JB, Hobson-Webb L, Passmore LV, Finkbinder AP, Cartwright MS. Case-control study of thromboembolic events associated with IV immunoglobulin. *J Neurol* 2009;256:339–42.
  63. Caress JB, Cartwright MS, Donofrio PD, Peacock JE Jr. The clinical features of 16 cases of stroke associated with administration of IVIg. *Neurology* 2003;60:1822–4.
  64. Go RS, Call TG. Deep venous thrombosis of the arm after intravenous immunoglobulin infusion: case report and literature review of intravenous immunoglobulin-related thrombotic complications. *Mayo Clin Proc* 2000;75:83–5.
  65. Elkayam O, Paran D, Milo R, Davidovitz Y, Almozino-Sarafian D, Zeltser D, et al. Acute myocardial infarction associated with high dose intravenous immunoglobulin infusion for autoimmune disorders. A study of four cases. *Ann Rheum Dis* 2000;59:77–80.
  66. Hefer D, Jaloudi M. Thromboembolic events as an emerging adverse effect during high-dose intravenous immunoglobulin therapy in elderly patients: a case report and discussion of the relevant literature. *Ann Hematol* 2004;83:661–5.
  67. Reinhart WH, Berchtold PE. Effect of high-dose intravenous immunoglobulin therapy on blood rheology. *Lancet* 1992;339:662–4.
  68. Dalakas MC. High-dose intravenous immunoglobulin and serum viscosity: risk of precipitating thromboembolic events. *Neurology* 1994;44:223–6.
  69. Crouch ED, Watson LE. Intravenous immunoglobulin-related acute coronary syndrome and coronary angiography in idiopathic thrombocytopenic purpura – a case report and literature review. *Angiology* 2002;53:113–17.
  70. Roemisch JR, Kaar W, Zoehling A, Kannicht C, Putz M, Kohla G, et al. Identification of activated FXI as the major biochemical root cause in IVIG batches associated with thromboembolic events. Analytical and experimental approaches resulting in corrective and preventive measures implemented into the Octagam® manufacturing process. *WebmedCentral Immunotherapy* 2011;2:WMC002002.
  71. Robertson VM, Dickson LG, Romond EH, Ash RC. Positive antiglobulin tests due to intravenous immunoglobulin in patients who received bone marrow transplant. *Transfusion* 1987;27:28–31.
  72. Daw Z, Padmore R, Neurath D, Cober N, Tokessy M, Desjardins D, et al. Hemolytic transfusion reactions after administration of intravenous immune (gamma) globulin: a case series analysis. *Transfusion* 2008;48:1598–601.
  73. Wilson JR, Bhoopalani H, Fisher M. Hemolytic anemia associated with intravenous immunoglobulin. *Muscle Nerve* 1997;20:1142–5.
  74. US Food and Drug Administration. Public Workshop – Strategies to Address Hemolytic Complications of Immune Globulin Infusions. 2014. <http://www.fda.gov/downloads/BiologicsBloodVaccines/NewsEvents/WorkshopsMeetingsConferences/UCM387078.pdf> (accessed June 3, 2014).
  75. Dhainaut F, Guillaumat PO, Dib H, Perret G, Sauer A, de Coupade C, et al. In vitro and in vivo properties differ among liquid intravenous immunoglobulin preparations. *Vox Sang* 2013;104:115–26.
  76. Bjoro K, Froland SS, Yun Z, Samdal HH, Haaland T. Hepatitis C infection in patients with primary hypogammaglobulinemia after treatment with contaminated immune globulin. *N Engl J Med* 1994;331:1607–11.
  77. Yap PL, McOmish F, Webster AD, Hammarstrom L, Smith CI, Bjorkander J, et al. Hepatitis C virus transmission by intravenous immunoglobulin. *J Hepatol* 1994;21:455–60.
  78. Ballou M. Intravenous immunoglobulins: clinical experience and viral safety. *J Am Pharm Assoc* 2002;42:449–59.
  79. Ballou M. Safety of IGIV therapy and infusion-related adverse events. *Immunol Res* 2007;38:122–32.
  80. Johnson RT, Gibbs CJ Jr. Creutzfeldt-Jakob disease and related transmissible spongiform encephalopathies. *N Engl J Med* 1998;339:1994–2004.
  81. Trejo SR, Hotta JA, Lebing W, Stenland C, Storms RE, Lee DC, et al. Evaluation of virus and prion reduction in a new intravenous immunoglobulin manufacturing process. *Vox Sang* 2003;84:176–87.
  82. Gardulf A, Andersen V, Bjorkander J, et al. Subcutaneous immunoglobulin replacement in patients with primary antibody deficiencies: safety and costs. *Lancet* 1995;345:365–9.
  83. Wasserman RL, Irani AM, Tracy J, Tsoukas C, Stark D, Levy R, et al. Pharmacokinetics and safety of subcutaneous immune globulin (human), 10% caprylate/chromatography purified in patients with primary immunodeficiency disease. *Clin Exp Immunol* 2010;161:518–26.
  84. Wasserman RL, Melamed I, Kobrynski L, et al. Efficacy, safety, and pharmacokinetics of a 10% liquid immune globulin preparation (GAMMAGARD LIQUID, 10%) administered subcutaneously in subjects with primary immunodeficiency disease. *J Clin Immunol* 2011;31:323–31.
  85. Hagan JB, Fasano MB, Spector S, Wasserman RL, Melamed I, Rojavin MA, et al. Efficacy and safety of a new 20% immune-globulin preparation for subcutaneous administration, IgPro20, in patients with primary immunodeficiency. *J Clin Immunol* 2010;30:734–45.
  86. Imbach P, Barandun S, d'Apuzzo V, Baumgartner C, Hirt A, Morell A, et al. High dose intravenous gammaglobulin for idiopathic thrombocytopenic purpura in childhood. *Lancet* 1981;1:1228–132.
  87. Orange JS, Hossny EM, Weiler CR, Ballou M, Berger M, Bonilla FA, et al. Use of intravenous immunoglobulin in human disease: a review of evidence by members of the Primary Immunodeficiency Committee of the American Academy of Allergy, Asthma and Immunology. *J Allergy Clin Immunol* 2006;117:S525–53.
  88. Ballou M. Mechanisms of action of intravenous immune serum globulin in autoimmune and inflammatory diseases. *J Allergy Clin Immunol* 1997;100:151–7.
  89. Blanchette VS, Luke B, Andrew M, Sommerville-Nielsen S, Barnard D, de Veber B, et al. A prospective, randomized trial of high-dose intravenous immune globulin G therapy, oral prednisone therapy, and no therapy in childhood acute immune thrombocytopenic purpura. *J Pediatr* 1993;123:989–95.
  90. Clynes R, Ravetch JV. Cytotoxic antibodies trigger inflammation through Fc receptors. *Immunity* 1995;3:21–6.
  91. Fehr J, Hofmann V, Kappeler U. Transient reversal of thrombocytopenia in idiopathic thrombocytopenic purpura by high-dose intravenous gammaglobulin. *N Engl J Med* 1982;306:1254–8.
  92. Bussel J. Modulation of Fc receptor clearance and antiplatelet antibodies as a consequence of intravenous immune globulin infusion in patient with immune thrombocytopenic purpura. *J Allergy Clin Immunol* 1989;84:566–78.

93. Debré M, Bonnet MC, Fridman WH, Carosella E, Philippe N, Reinert P, et al. Infusion of Fc gamma fragments for treatment of children with acute immune thrombocytopenic purpura. *Lancet* 1993;342:945–9.
94. Junghans RP, Anderson CL. The protection receptor for IgG catabolism is the beta2-microglobulin-containing neonatal intestinal transport receptor. *Proc Natl Acad Sci U S A* 1996;93:5512–16.
95. Li N, Zhao M, Hilario-Vargas J, Prisanh P, Warren S, Diaz LA, et al. Complete FcRn dependence for intravenous Ig therapy in autoimmune skin blistering diseases. *J Clin Invest* 2005;115:3440–50.
96. Akilesh S, Petkova S, Sproule TJ, Shaffer DJ, Christianson GJ, Roopenian D. The MHC class I-like Fc receptor promotes humorally mediated autoimmune disease. *J Clin Invest* 2004;113:1328–33.
97. Hansen RJ, Balthasar JP. Effects of intravenous immunoglobulin on platelet count and antiplatelet antibody disposition in a rat model of immune thrombocytopenia. *Blood* 2002;100:2087–93.
98. Daeron M. Fc receptor biology. *Annu Rev Immunol* 1997;15:203–34.
99. Kimberly RP, Salmon JE, Edberg JC. Receptors for immunoglobulin G. *Arthritis Rheum* 1995;38:306–14.
100. Samuelsson A, Towers TL, Ravetch JV. Anti-inflammatory activity of IVIG mediated through the inhibitory Fc receptor. *Science* 2001;291:484–6.
101. Kaneko Y, Nimmerjahn F, Madaio MP, Ravetch JV. Pathology and protection in nephrotoxic nephritis is determined by selective engagement of specific Fc receptors. *J Exp Med* 2006;203:789–97.
102. Salmun LM, Barlan I, Wolf HM, Eibl M, Twarog FJ, Geha RS, et al. Effects of intravenous immunoglobulin on steroid consumption in patients with severe asthma: a double-blind, placebo-controlled, randomized trial. *J Allergy Clin Immunol* 1999;103:810–15.
103. Mazer BD, Gelfand EW. An open-label study of high-dose intravenous immunoglobulin in severe childhood asthma. *J Allergy Clin Immunol* 1991;87:976–83.
104. Anthony RM, Nimmerjahn F, Ashline DJ, Reinhold VN, Paulson JC, Ravetch JV. Recapitulation of IVIG anti-inflammatory activity with a recombinant IgG Fc. *Science* 2008;320:373–6.
105. Anthony RM, Wermeling F, Karlsson MC, Ravetch JV. Identification of a receptor required for the anti-inflammatory activity of IVIG. *Proc Natl Acad Sci U S A* 2008;105:19571–8.
106. Anthony RM, Kobayashi T, Wermeling F, Ravetch JV. Intravenous gammaglobulin suppresses inflammation through a novel T(H)2 pathway. *Nature* 2011;475:110–13.
107. Kaveri SV, Lacroix-Desmazes S, Bayry J. The antiinflammatory IgG. *N Engl J Med* 2008;359:307–9.
108. Basta M, Kirshbom P, Frank MM, Fries LF. Mechanism of therapeutic effect of high-dose intravenous immunoglobulin: attenuation of acute, complement-dependent immune damage in a guinea pig model. *J Clin Invest* 1989;84:1974–81.
109. Frank MM, Basta M, Fries LF. The effects of intravenous immune globulin on complement-dependent immune damage of cells and tissues. *Clin Immunol Immunopathol* 1991;62:S82–6.
110. Basta M, Fries LF, Frank MM. High doses of intravenous Ig inhibit in vitro uptake of C4 fragments onto sensitized erythrocytes. *Blood* 1991;77:376–80.
111. Dalakas MC. Polymyositis, dermatomyositis, and inclusion-body myositis. *N Engl J Med* 1991;325:1487–98.
112. Dalakas MC, Illa I, Dambrosia JM, Soueidan SA, Stein DP, Otero C, et al. A controlled trial of high-dose intravenous immunoglobulin infusions as treatment for dermatomyositis. *N Engl J Med* 1993;329:1993–2000.
113. Dalakas MC. Clinical relevance of IVIg in the modulation of the complement-mediated tissue damage: implications in dermatomyositis, Guillain Barre syndrome and myasthenia gravis. In: Kazatchkine MD, Morell A, editors. *Intravenous Immunoglobulin Research and Therapy*. New York: Informa Health; 1996. p. 89–93.
114. Soueidan SA, Dalakas MC. Treatment of autoimmune neuromuscular diseases with high-dose intravenous immune globulin. *Pediatr Res* 1993;33(Suppl.):S95–100.
115. Dalakas MC. Controlled studies with high-dose intravenous immunoglobulin in the treatment of dermatomyositis, inclusion body myositis, and polymyositis. *Neurology* 1998;51(Suppl. 5):S37–45.
116. Basta M, Dalakas MC. High-dose intravenous immunoglobulin exerts its beneficial effect in patients with dermatomyositis by blocking endomysial deposition of activated complement fragments. *J Clin Invest* 1994;94:1729–35.
117. Chang J, Shi PA, Chiang EY, Frenette PS. Intravenous immunoglobulins reverse acute vaso-occlusive crises in sickle cell mice through rapid inhibition of neutrophil adhesion. *Blood* 2008;111:915–23.
118. Viard I, Wehrli P, Bullani R, Schneider P, Holler N, Salomon D, et al. Inhibition of toxic epidermal necrolysis by blockade of CD95 with human intravenous immunoglobulin. *Science* 1998;282:490–3.
119. Aukrust P, Muller F, Nordoy I, Haug CJ, Froland SS. Modulation of lymphocyte and monocyte activity after intravenous immunoglobulin administration in vivo. *Clin Exp Immunol* 1997;107:50–6.
120. Amran D, Renz H, Lack G, Bradley K, Gelfand EW. Suppression of cytokine-dependent human T-cell proliferation by intravenous immunoglobulin. *Clin Immunol Immunopathol* 1994;73:180–6.
121. Ephrem A, Chamat S, Miquel C, Fisson S, Mouthon L, Caligiuri G, et al. Expansion of CD4+CD25+ regulatory T cells by intravenous immunoglobulin: a critical factor in controlling experimental autoimmune encephalomyelitis. *Blood* 2008;111:715–22.
122. Furuno K, Yuge T, Kusahara K, Takada H, Nishio H, Khajoo V, et al. CD25+CD4+ regulatory T cells in patients with Kawasaki disease. *J Pediatr* 2004;145:385–90.
123. De Groot AS, Moise L, McMurry JA, Wambre E, Van Overtvelt L, Moingeon P, et al. Activation of natural regulatory T cells by IgG Fc-derived peptide ‘Tregitopes’. *Blood* 2008;112:3303–11.
124. Tjon AS, Tha-In T, Metselaar HJ, van Gent R, van der Laan LJ, Groothuisink ZM, et al. Patients treated with high-dose intravenous immunoglobulin show selective activation of regulatory T cells. *Clin Exp Immunol* 2013;173:259–67.
125. Kaufman GN, Massoud AH, Audusseau S, Banville-Langelier AA, Wang Y, Guay J, et al. Intravenous immunoglobulin attenuates airway hyperresponsiveness in a murine model of allergic asthma. *Clin Exp Allergy* 2011;41:718–28.
126. Massoud AH, Guay J, Shalaby KH, Bjur E, Ablona A, Chan D, et al. Intravenous immunoglobulin attenuates airway inflammation through induction of forkhead box protein 3-positive regulatory T cells. *J Allergy Clin Immunol* 2012;129:1656–65 e3.
127. Maddur MS, Vani J, Hegde P, Lacroix-Desmazes S, Kaveri SV, Bayry J. Inhibition of differentiation, amplification, and function of human TH17 cells by intravenous immunoglobulin. *J Allergy Clin Immunol* 2011;127:823–30 e1–7.



# Hematopoietic Stem Cell Therapy

DONALD B. KOHN | LUIGI D. NOTARANGELO

## KEY POINTS

- Hematopoietic stem cell transplantation (HSCT) can correct many primary immune deficiencies (PIDs) by providing a normal source that produces functional leukocytes to replace the defective cells.
- Best outcomes are obtained when using matched sibling donor bone marrow, although results using matched unrelated adult or umbilical cord blood donors or haploidentical (parental) donors continue to improve.
- Multiple factors affect outcomes, include the specific PID being treated, the general health of the recipient, presence or absence of intercurrent infections, the choice of pretransplant conditioning regimen used to facilitate engraftment and the source of donor hematopoietic stem cells.
- Several clinical trials of gene therapy – autologous transplantation of genetically corrected hematopoietic stem cells – using murine retroviral vectors showed significant immune reconstitution. However, there was a high incidence of vector-related leukoproliferative complications.
- Current trials mostly use lentiviral vectors, which may be more effective and safer than the murine retroviral vectors, further improving outcomes for gene therapy for PID.

Several forms of primary immune deficiency (PID) result from mutations of genes involved in the production, function or survival of leukocytes. Therefore, these PIDs can be treated by allogeneic hematopoietic stem cell transplantation (HSCT) that provides patients with a new source of genetically normal leukocytes. The first successful clinical allogeneic bone marrow transplant (BMT) was performed in 1968 for a patient with severe combined immune deficiency (SCID), resulting in sustained reconstitution of immunity that has lasted now for several decades.<sup>1</sup> Since that time, allogeneic HSCT has become the standard of care for patients with SCID and is often used for patients with other severe, life-threatening forms of PID. Patients with less severe PIDs, especially those primarily affecting production of antibodies that can be replaced with intravenous gammaglobulin administration, generally are not treated with HSCT.

The major barriers to allogeneic HSCT are immunologic. In solid organ transplantation, a recipient's T cells can reject the organ donor's cells. Graft rejection is less of a problem in severely immune deficient recipients, such as patients with SCID who lack T lymphocytes, and in some cases also B and NK cells. However, in some of the PIDs that retain partial

function of the immune system, a significant risk for graft rejection remains. In most cases, transplant recipients need partial or essentially complete ablation of their endogenous immune and hematopoietic systems to achieve enduring engraftment of donor HSCs. Definition of optimal pretransplant conditioning regimens remains one of the major areas of discovery in the field.

The flipside of graft rejection, which is mostly limited to HSCT and only rarely encountered in solid organ transplant, is graft versus host disease (GvHD), where alloreactive T cells from the donor that are given with the allogeneic bone marrow can, in effect, reject the recipient's cells. GvHD can be severe, chronic and even fatal; complications increase in frequency and severity with increasing degree of mismatch between the donor and the recipient. Efforts to prevent or suppress GvHD, by administration of immune suppressive medications or by depleting the donor's mature T lymphocytes from the graft, often result in prolonged immune deficiency that poses high risks for opportunistic infections, especially beyond the infant period when patients may bear latent herpesviruses, BK virus or adenovirus.

## Severe Combined Immune Deficiency

Severe combined immune deficiency is the most severe of the PIDs, with inherited absence of T and B cell function (and variable NK activity). In the absence of medical intervention, infants with SCID suffer a high rate of early mortality from infections. SCID is a clinical phenotype which may result from defects in any one of more than 12 genes (Box 16-1). The clinical research associated with the treatment of human SCID has produced many of the major advances in the field of HSCT<sup>1-6</sup> (Box 16-2).

Allogeneic HSCT can be curative for SCID when bone marrow from a human leukocyte antigen (HLA)-matched sibling donor (MSD) is used, with most centers reporting greater than 90% long-term survival. PID patients who receive an allogeneic HSC transplant from an HLA-MSD generally achieve high rates of immune reconstitution and good quality of life. For patients with SCID, HLA-MSD marrow can be infused without chemotherapy or radiation 'conditioning', and will appropriately restore T cell function in most patients. Most other PIDs require full or partial marrow 'conditioning' for proper engraftment of donor cells without rejection.

By contrast, HSCT from HLA-mismatched donors (e.g. a haploidentical/haplo-disparate parent) carries a significant risk of severe GvHD, because the donor's T cells contained in the graft would react against the non-shared HLA proteins (such as those inherited from the other parent). To prevent this, methods to deplete T lymphocytes from bone marrow in order to limit GvHD risks were developed in the mid 1970s (Box 16-3). Using

**BOX 16-1 GENETIC CAUSES OF HUMAN SCID****SIGNALING DEFECTS**

Common  $\gamma$  cytokine receptor chain (*IL2RG* gene) (XSCID) (~30%)  
 JAK3  
*IL-7R $\alpha$*   
 CD3 chains (CD3 $\delta$ , CD3 $\epsilon$ , CD3 $\zeta$ )  
 CD45

**RECOMBINASE DEFECTS**

*RAG1/RAG2*  
 Artemis (*DLCRE1C*)  
 DNA-dependent protein kinase catalytic subunit (DNA-PKcs)  
 Cernunnos

**METABOLIC DEFECTS**

Adenosine deaminase (*ADA*) (10–15%)  
 Purine nucleotide phosphorylase (*PNP*)  
 Adenylate kinase 2 (*AK2*)

**BOX 16-2 HISTORICAL LANDMARKS FOR THE USE OF HSCT FOR SCID**

First successful human BMT (1968)<sup>1</sup>  
 First use of matched unrelated donor (MUD) bone marrow (1973)<sup>2</sup>  
 First transplant with haploidentical (parent) bone marrow (1975)<sup>3</sup>  
 First approach using gene therapy (1990)<sup>4,5</sup>  
 First 'cure' using gene therapy (2000)<sup>6</sup>

**BOX 16-3 METHODS FOR T CELL DEPLETION OF DONOR BONE MARROW**

Complement-mediated lysis  
 Counterflow centrifugation elutriation  
 Density gradients  
 Polyclonal antibodies (ALG, ATG)  
 Monoclonal antibodies (anti-CD2, anti-CD3, anti-CD4, anti-CD5, anti-CD6, anti-CD7, anti-CD8, anti-CD52, TcR $\alpha\beta$ , CD45RA)  
 Soy bean agglutinin/E-rosette with sheep red blood cells  
 Stem cell enrichment (e.g. anti-CD34)

such approaches to deplete T cells, marrow from parental donors, who are only matched by one HLA haplotype and therefore mismatched for a full HLA haplotype, has been frequently used for SCID patients lacking an HLA-matched donor; 50% to 80% of SCID patients have realized long-term survival.<sup>7–9</sup> The lower success rate with haploidentical transplants may reflect the morbidity and mortality associated with: (1) the increased risks of graft rejection and/or GvHD; (2) the T cell depletion that is utilized to prevent GvHD which slows immune reconstitution and prolongs the period of increased susceptibility to infections; and (3) the adverse effects secondary to the possible use of chemotherapy to make space and eliminate residual immunity.

One of the continuing controversies about the optimal approach to haploidentical HSCT for SCID concerns the necessity, or lack thereof, of pretransplant conditioning with chemotherapy or other immune suppressive medications to facilitate long-term engraftment of donor HSCs. In the absence of conclusive data from randomized clinical trials, there are strong advocates of either of these approaches.

A few very active centers have performed haploidentical transplants for SCID patients for more than three decades, successfully giving T cell-depleted bone marrow from a parent without any preconditioning therapy or immune suppressive medicines to prevent GvHD.<sup>8</sup> Most of these patients have had successful T cell immune reconstitution lasting decades, although it will take longer observation to assess the durability of T cell function. However, more than half of them have had inadequate B cell reconstitution and were reported still to require regular administration of intravenous gammaglobulin, possibly indicating a failure to engraft sufficient numbers of HSCs in the absence of marrow conditioning.

Use of cytoreductive conditioning prior to HSCT for SCID typically leads to donor cell chimerism in all lineages, indicating replacement of the endogenous HSCs with those of the donor. This full donor engraftment may lead to more sustained production of new T cells and may lead to increased numbers and activity of B and NK cells.<sup>10</sup> However, the acute and long-term toxicities of the chemoablative regimens may lead to increased toxicity and mortality in the initial period, especially in patients with preexisting infections, and may cause long-term growth, endocrinologic and neurocognitive abnormalities.<sup>11,12</sup>

Historically, less has been done using matched unrelated donor marrow (MUD) or cord blood for transplantation of SCID patients who do not have an HLA-MSD. HSC transplantation using MUD or cord blood carries increased risks for GvHD, compared to the use of marrow from an MSD.<sup>13</sup> The frequency of severe GvHD in MUD marrow and cord blood HSC transplantation is in the range of 25–50% and 20–40%, respectively. In addition, HSC transplantation with cord blood has a risk for engraftment failure between 10% and 20%. These increased complications are likely to be due to more mismatches for non-HLA (minor) antigens. Generally, full cytoablation and GvHD prophylaxis (i.e. post-transplant immune suppression) are needed to prevent graft rejection or GvHD.<sup>14</sup>

In the past few years, a consortium of investigators from North America involved in the clinical care of patients with severe PIDs has organized as the Primary Immune Deficiency Treatment Consortium (PIDTC) to compile data on treatment and outcomes, mainly focussed on hematopoietic transplants.<sup>15</sup> Results were analyzed retrospectively for transplants performed between 2000 and 2009 in 240 patients with typical or 'classical' SCID.<sup>16</sup> Outcomes for infants treated at less than 3.5 months of age were excellent (94% 5-year survival), independently of the source of HSC used. For patients older than 3.5 months of age at the time of transplant, the presence of ongoing infections, mostly viral, led to poorer survival (50% 5-year survival). Among patients who were infected at the time of HSCT, the outcome was worse in those who received pretransplant conditioning (31.2% 5-year survival) than in those transplanted without conditioning (61.4% 5-year survival). Nevertheless, for surviving infants, T and B cell functions were more frequently better in those who received pretransplant conditioning, which raises a conundrum in defining the best approach (Box 16-4). Importantly, newborn screening for SCID is now available in many States and may permit rapid identification of affected babies, who can be referred to HSCT before developing infections. While this is expected to result in improved outcome, the role (and intensity) of pretransplant conditioning in this group of very young infants remains to be defined.

Because SCID is rare, and may be caused by various genetic defects, few studies have analyzed the outcome of HSCT in

**BOX 16-4 POTENTIAL TRANSPLANT DONOR AND APPROACHES FOR SCID INFANTS**

MSD when available for all, without conditioning  
 Infants 3.5 months or less: MSD, MMFD, MUD (adult or cord blood) or autologous/gene therapy; with or without conditioning, per center experience  
 Infants >3.5 months without resistant viral infection: MSD, MMFD, MUD (adult or cord blood), or autologous/gene therapy; with or without conditioning, per center experience  
 Infants >3.5 months with resistant infection: MSD, MMFD, MUD (adult or cord blood) or autologous/gene therapy; without conditioning. May develop full or partial T cell immunity, but good B and NK cell function unlikely. Second, conditioned transplant may be considered at time of improved health to improve immunity

MSD, Matched sibling donor; MMFD, Mismatched family donor, typically parent; MUD, Matched unrelated donor.

specific forms of SCID. An international consortium has reported on the outcome of HSCT in 106 patients with ADA deficiency.<sup>17</sup> Overall survival after HSCT from MSD or matched family donors (86% and 81%, respectively) was better than from MUDs (66%;  $P < .05$ ) or haploidentical donors (43%;  $P < .001$ ). Survival was superior for patients who received unconditioned transplants than for those who received myeloablative conditioning (81% vs 54%, respectively;  $P < .003$ ). However, unconditioned transplantation was associated with a higher risk of non-engraftment. Long-term studies showed that most surviving patients attained durable immune reconstitution.

Defects of V(D)J recombination due to RAG, Artemis, DNA PKcs, or Cernunnos mutations cause T<sup>+</sup>B<sup>+</sup>NK<sup>+</sup> SCID. In addition, Artemis and DNA PKcs deficiency cause increased cellular radiosensitivity, which may lead to additional toxicity when conditioning regimens are used for HSCT. Schuetz et al have reported on the outcome of HSCT in patients with Artemis mutations vs patients with RAG1/2 deficiency.<sup>18</sup> Survival after MSD HSCT was comparable in the two groups. However, patients with Artemis deficiency had an increased rate of late complications, including poor growth and requirement for nutritional support, autoimmune manifestations, growth hormone deficiency, hypothyroidism and dental anomalies.

## Wiskott-Aldrich Syndrome

The pathophysiology, presentation, diagnosis and general management of Wiskott-Aldrich syndrome (WAS) are discussed in Chapter 9.

Bach and colleagues performed the first sibling HSCT for WAS.<sup>19</sup> MSD HSCT provides the best outcome for WAS patients and is established as the standard of care when available.<sup>20</sup> In recent years, advances in transplant methods have significantly improved outcome of MUD HSCT also in WAS patients less than 5 years old. In particular, in a recent multicenter international study of 194 patients with WAS who received HSCT in the period 1990–2009, 5-year survival was 84%, and it was 73.3% in those who received MUD HSCT at less than 5 years of age.<sup>21</sup>

With current approaches, the majority (72%) of WAS patients attain full chimerism after HSCT. However, mixed chimerism may be associated with complications. In particular,

post-HSCT autoimmune disease is frequently observed. Host WASp-deficient B cells that persist after transplantation due to mixed donor chimerism may not respond fully to regulatory cues and produce autoantibodies.<sup>22,23</sup> Furthermore, low myeloid chimerism is associated with an increased risk of persistent thrombocytopenia.<sup>21</sup> Overall, HLA-MSD HSCT in patients who are less than 5 years of age and achieve full donor chimerism has the best outcome, but if an MSD is unavailable, a matched unrelated donor HSCT is a viable option.

## Chronic Granulomatous Disease

The pathophysiology, presentation, diagnosis and general management of chronic granulomatous disease (CGD) are discussed in Chapter 11 (and reference 24). It is estimated that the median lifespan of patients with CGD is 20 to 25 years and the mortality rate is 2% to 5% per year.<sup>25</sup> Since many CGD patients live into adulthood, in contrast to the near certain early mortality of SCID, decisions are more difficult concerning the potential benefits of transplant versus the risks that are associated with a myeloablative HSCT.<sup>26–28</sup> Theoretically, reduced intensity conditioning decreases the toxicity associated with the conditioning regimen and T cell depletion decreases the risks for GvHD.<sup>29</sup> Recently, a multicenter European study using reduced intensity conditioning and matched sibling or matched unrelated donors for CGD reported excellent outcomes for 56 CGD patients; overall survival was reported as 93% with event-free survival (surviving with donor engraftment) at 89%.<sup>30</sup>

## Hemophagocytic Lymphohistiocytosis

Hemophagocytic lymphohistiocytosis (HLH) is a rare disorder that is characterized by highly activated macrophages and lymphocytes. Primary or familial HLH is inherited as an autosomal recessive disease, while secondary HLH is an acquired form that is usually associated with a viral illness. While initially considered to be a malignant disorder of histiocytes, more recent understanding of HLH classifies it as a PID, with defects in genes involved in transport and/or release of cytolytic granules, such as perforin, *MUNC 13-4*, *STX11*, *STXBP2*. Inability to kill activated cells results in persistent stimulation of the immune system with increased production of IFN- $\gamma$  and uncontrolled activation of macrophages.

The first curative HSCT for HLH was performed in 1986.<sup>31</sup> Currently, standard treatment for the familial type involves induction immunochemotherapy with etoposide, dexamethasone and cyclosporin A, followed by HSCT. An earlier clinical trial, HLH-94, showed that the outcomes with MUD HSCT were equivalent to those with HLA-MSD HSCT (67% vs 68%). Patients who received transplants from mismatched related donors (usually haploidentical) had a survival rate of 43%.<sup>32,33</sup> More recently, significant improvement of outcome has been reported after HSCT for HLH with use of a reduced intensity conditioning (RIC) regimen. In a series of 40 patients who received HSCT for HLH at Cincinnati Children's Hospital, 3-year overall survival was 43% for those who received fully myeloablative conditioning (MAC) vs 92% for those who received RIC.<sup>34</sup> This difference was mostly due to increased risk of early death (<6 months after HSCT) in patients receiving MAC. Although RIC is associated with an increased rate of mixed chimerism, levels of 10–20% donor chimerism apparently suffice to control HLH.

## Other Primary Immune Deficiencies Amenable to Hematopoietic Stem Cell Transplantation

HSCT is the treatment of choice also for severe defects that affect late stages of T cell development (such as ZAP-70 deficiency and MHC class II deficiency), other forms of combined immunodeficiency (X-linked hyper-IgM syndrome, DOCK8 deficiency), immunodeficiency with severe immune dysregulation (IPEX), and X-linked lymphoproliferative disease (XLP). At variance with SCID, these PIDs are characterized by the presence of autologous T cells, requiring use of conditioning in preparation for HSCT. Less severe PIDs, such as X-linked agammaglobulinemia (XLA), common variable immune deficiency, selective antibody defects, etc., have not been routinely subjected to HSCT thus far, since the risks of HSCT may exceed those of the underlying disorder.

## Gene Therapy Using Hematopoietic Stem Cells

### GENE THERAPY FOR ADA-DEFICIENT SCID

Gene therapy was conceived as an alternative to allogeneic HSCT in which a patient's own HSCs would have a normal copy of the disease-related gene inserted (Figure 16-1). Autologous gene therapy should avoid the immunologic complications of allogeneic HSCT (graft rejection and GvHD) but could yield the same clinical benefits. Based on the known therapeutic effects from non-myeloablated MSD transplants for SCID with only low engraftment of donor HSCs, it was postulated that in SCID there would be selective lymphoid expansion from a small number of gene-corrected HSCs that could amplify the effects of low efficiency gene transfer.

Six clinical trials of gene therapy for ADA-deficient SCID were performed in the 1990s.<sup>4,5,35–40</sup> All of these studies used retroviral vectors to transfer a normal ADA cDNA, targeting either mature T lymphocytes that developed after PEG-ADA

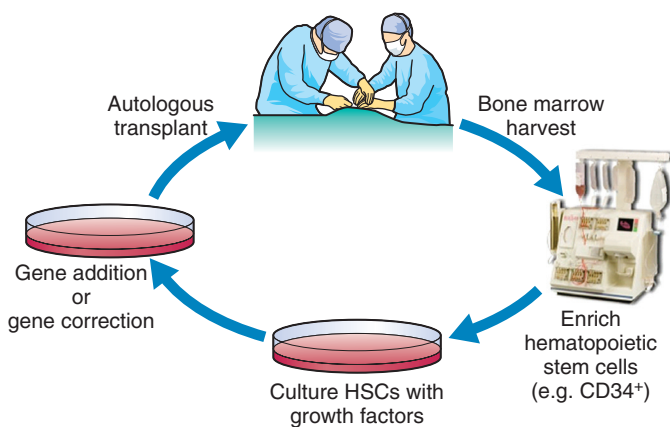
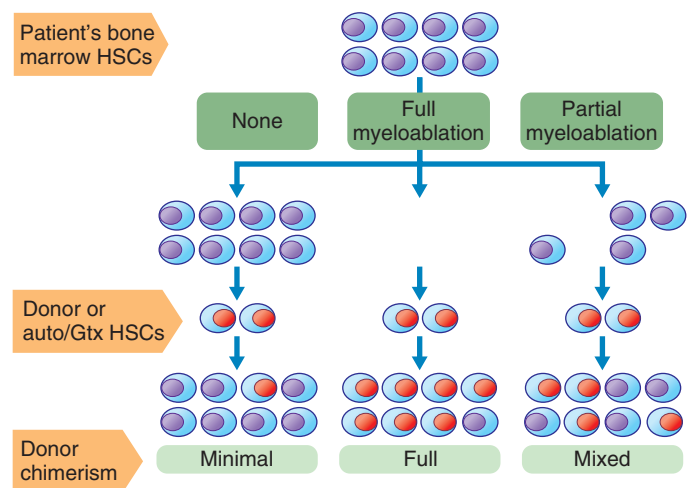

**Figure 16-1** Gene therapy using autologous hematopoietic stem cells. Bone marrow is harvested from the PID patient. In the laboratory, the HSCs are enriched by immune affinity with a monoclonal antibody to the CD34 antigen. The CD34 enriched cells are cultured with hematopoietic growth factors to activate the cells and then gene addition or gene correction is performed. The HSCs are then transplanted by intravenous infusion back into the patient.

therapy, or CD34<sup>+</sup> HSCs from autologous bone marrow or umbilical cord blood.<sup>41</sup> While there were no serious adverse events from the gene transfer in any of the subjects, there were also no significant clinical benefits. Overall, survival and immune function in these subjects were comparable to those in patients receiving only PEG-ADA therapy.

During the 1990s, incremental progress was made with techniques of gene transfer and stem cell culture.<sup>42–46</sup> Additionally, the use of RIC prior to allogeneic HSCT was shown to allow a moderate degree of engraftment of donor cells, with significantly reduced acute toxicity.<sup>47,48</sup> Such non-myeloablative conditioning was postulated to be beneficial in the autologous gene therapy setting (Figure 16-2). Based on these advances, second-generation clinical trials of gene therapy for SCID were begun in the late 1990s.

The investigators at the San Raffaele Telethon Institute for Gene Therapy in Milan, Italy, made a major advance in the field with their clinical trial of gene therapy for ADA-deficient SCID. Initial results were reported in 2002 on two ADA-SCID infants treated using retroviral-mediated ADA gene transfer to bone marrow CD34<sup>+</sup> cells.<sup>49</sup> Two important variables were changed, compared to earlier trials. First, the patients were given RIC, using a moderate dosage of busulfan (4 mg/kg, approximately ¼ of ‘full dose’) to eliminate some of the endogenous HSCs prior to infusion of the gene-corrected bone marrow cells. Second, the patients were *not* given PEG-ADA enzyme replacement therapy, which was expected to allow the maximum selective advantage of gene-corrected T cells to manifest. Indeed, over the first 6 to 9 months, immune function was largely restored, with the development of antigen-specific T cell responses and antibody production. Measurements of gene marking showed that 75–100% of T, B and NK cells contained the transferred gene, consistent with the strong purported selective advantage for ADA-expressing lymphocytes. At the same time, 1–10% of myeloid cells contained the gene, which was a



**Figure 16-2** Outcome after HSCT with full, partial or no myeloablative conditioning. If HSCs are transplanted from an allogeneic donor or as gene-corrected (Gtx) autologous cells with no pretransplant conditioning, only minimal chimerism of donor cells will occur (lower left). If full myeloablation is given, essentially complete donor cell chimerism will be achieved (lower middle). If partial myeloablation is administered, as has been done in some gene therapy clinical trials, mixed chimerism will be achieved with a significant fraction of donor or gene-corrected cells engrafted (lower right).



level significantly higher than that seen in earlier studies in which cytoreductive chemotherapy was not given.

Further results of this approach have now been reported from Milan, with 8 of 10 subjects realizing excellent and sustained immune reconstitution.<sup>50</sup> Similar studies at University College London/Great Ormond Street Hospital in London, UK, and in the USA at Children's Hospital Los Angeles, the University of California, Los Angeles, and the National Human Genome Research Institute, NIH, have led to similar clinically beneficial results.<sup>51,52</sup> Of at least 40 ADA-SCID patients treated by gene therapy using retroviral vectors and non-myeloablative conditioning in these studies, all are surviving and approximately 75% have sufficient immune restoration to remain well without other treatment, such as enzyme replacement therapy or allogeneic HSCT. No complications from genotoxic effects of the vectors have been observed in any, in contrast to findings in other diseases (see below). Thus, for ADA-deficient SCID patients lacking an HLA-MSD, gene therapy has become a proven therapeutic modality.

### GENE THERAPY FOR XSCID

The next PID approached as a candidate for gene therapy was X-linked SCID (XSCID), caused by mutations of the common cytokine receptor  $\gamma$  chain ( $\gamma$ c or IL2R $\gamma$ ). Investigators at the Hopital Necker- Enfants Malades in Paris, France, instituted a clinical trial of retroviral-mediated transfer of a normal human  $\gamma$ c cDNA into CD34<sup>+</sup> cells from bone marrow of infants with XSCID.<sup>9,53</sup> In this trial, the transduced CD34<sup>+</sup> cells were reinfused without any prior cytoreduction, counting on the very potent selective survival advantage of the  $\gamma$ c-corrected lymphoid cells to repopulate the immune system from a low level of gene-modified HSCs. No adverse events were noted in the initial years in 9 treated subjects. The  $\gamma$ c gene was present and expressed in T, NK and B cells. Over the initial 2 to 5 months, 9 of 10 infants developed normal numbers of T and NK cells, with good immune function. While B cell numbers remained low, protective levels of antibodies were produced and some of the subjects were removed from routine gammaglobulin treatment. The subjects were in good health over the first 1 to 2 years, without opportunistic infections, and were growing and developing without protective isolation. Ten XSCID infants were treated in a similar clinical trial by investigators at the Institute of Child Health, University College London, UK, with similarly good outcome.<sup>54</sup>

Longer-term follow-up of subjects in both the French and British trials was published and reported sustained T cell immunity in those achieving initial reconstitution.<sup>55,56</sup> However, B cell function allowing independence from IVIG replacement therapy was achieved in only 4 of 7 and 5 of 10, respectively, with essentially no gene-corrected B cells detected and a paucity of memory B cells; apparently, gene-corrected T cells are not of adequate help to induce full maturation and function in the non-gene-corrected B cells.

However, 5 subjects from these two trials subsequently developed a leukemia-like complication, with escalating white blood cell counts, 2.5–5 years after the gene therapy procedures. Four of these subjects have been successfully treated for the lymphoproliferative syndrome and have retained the benefits of the gene therapy on immune reconstitution, but one died as a result of this complication. Investigations have implicated the process of insertional oncogenesis, in which the retroviral vector

integrates semirandomly into different chromosomal sites in each transduced cell; integrants adjacent to cellular genes that mediate proliferation or survival may be inappropriately *trans*-activated by transcriptional elements of the vector, such as the potent enhancers present in the long terminal repeats (LTRs). It remains uncertain why the complication of insertional oncogenesis with lymphoproliferation was seen in 25% of the XSCID subjects but in none of the more than 40 subjects with ADA-deficient SCID.<sup>57–61</sup>

Faced with these mixed results with life-saving immune reconstitution in the majority of XSCID subjects using gene therapy, but the potential for a severe treatment-related complication, the relative risks and benefits need to be compared to the current therapeutic alternative for these subjects – allogeneic HSCT from a haploidentical or MUD donor. SCID patients with allogeneic donors other than HLA-matched siblings have had survival rates of 50% to 80% with restored T cell immunity, as discussed previously. However, more than half of these patients may fail to produce protective antibodies, and there are risks of GvHD and post-transplant Epstein-Barr virus (EBV)-driven lymphoproliferative disease (LPD). Gene therapy for XSCID using retroviral vectors led to immune restoration in 90% (18 of 20) of patients, but with a 25% incidence of LPD.

Notably, this same approach for gene therapy has been applied to older XSCID subjects, most of whom had undergone prior HSCT from haploidentical donors that resulted in only partial immune reconstitution with ongoing poor health.<sup>62,63</sup> These adolescent subjects showed minimal responses to the gene therapy, suggesting that their older age was associated with inadequate thymic function to support *de novo* lymphopoiesis; it is uncertain if the prior transplants were associated with GvHD, which is known to impair thymic function.

The way forward for gene therapy for XSCID lies in evaluating new vector designs that lack the strong LTR enhancer elements (so-called 'self-inactivating' or 'SIN' vectors), which have been shown by *in vitro* and murine transplant studies to have significantly lowered risks for causing insertional oncogenesis.<sup>64</sup> Ideally, these improved vectors will lead to similar levels of immune reconstitution, with minimal or no occurrences of insertional oncogenesis. One such trial with use of a SIN  $\gamma$ -retroviral vector to treat infants with XSCID without conditioning regimen is currently underway at five collaborating institutions in London, Paris, Boston, Cincinnati and Los Angeles. Initial results have shown ability to attain T cell immune reconstitution, and no clonal proliferations have been observed so far, although follow-up is still limited.<sup>9</sup> More recently, De Ravin and colleagues opened a second clinical trial to treat older, partially reconstituted XSCID patients, in the present form using a lentiviral vector and RIC (6 mg/kg busulfan). Initial results indicate some improvements of B cell immunity and overall wellbeing.<sup>65</sup>

### GENE THERAPY FOR CGD

Another major PID that has been approached in several gene therapy clinical trials is CGD. The cDNA for the oxidases responsible for the X-linked form (gp91 $phox$ ) and most common autosomal forms (p47  $phox$ , p67  $phox$  or p22  $phox$ ) were cloned and placed into retroviral vectors. Preclinical studies using patient-derived cells and murine gene knockout models provided evidence that gene transfer could at least partially restore the defective oxidase function in myeloid cells.<sup>66,67</sup>

Initial trials in X-linked CGD (the most common form of the disease) used murine leukemia virus (MLV)-based retroviral vectors, targeted G-CSF mobilized CD34<sup>+</sup> peripheral blood stem cells (PBSC) and did not administer cytoreductive chemotherapy. Neutrophils were produced in vivo in multiple subjects that had their functional activity restored, based upon sensitive flow cytometric assays, but these were present at very low frequencies and only transiently.<sup>68,69</sup>

A later study performed at the German Cancer Research Center added cytoreductive conditioning with 8 mg/kg of busulfan (approximately two times higher than the dose used in the ADA-deficient SCID studies) and used a retroviral vector derived from the murine spleen focus forming virus (SFFV) which has LTRs that are highly potent in myeloid progenitor cells expressing the normal human gp91*phox*.<sup>70</sup> Two young men in their twenties with X-CGD and lifelong histories of chronic infections poorly responsive to intensive medical therapy were treated. They had clinically beneficial responses to the treatment with resolution of the longstanding infections. The production of gene-corrected, oxidase (+) neutrophils was readily detected; the frequencies of gene-containing neutrophils increased from 20% in the first few months after transplant to levels exceeding 60% over the next few months. Both patients developed monosomy 7 and myelodysplasia. One of these patients died as a result of gastrointestinal infection, at a time when there was loss of expression of oxidase activity in neutrophils, despite the continued presence of gene-containing cells.<sup>71</sup>

The highly dichotomous outcome of clinical benefit followed by severe adverse event in these CGD patients is highly reminiscent of the XSCID studies. For CGD, the use of a vector with a potent myeloid-type LTR promoter led to myeloproliferation, while there was lymphoproliferation in the XSCID studies where the MLV LTR is more active in lymphoid cells. It is known from research on wild-type retroviruses that the virus's LTRs may play a major role in defining the disease tropism.<sup>72</sup> Retroviral vectors used to drive high-level expression of a transgene in a specific lineage may predispose that lineage to insertional oncogenic effects.

The unexpected complications that occurred in these patients treated for PID led to major increases in the understanding of these risks, their underlying mechanisms and potential ways to overcome them. Some of these improved approaches will be discussed below. A lentiviral vector has been developed to express the gp91*phox* cDNA under transcriptional control of a chimeric promoter with expression relatively specific to mature myeloid cells; this vector could be active in granulocytes and monocytic cells but have a reduced potential to transform stem and progenitor cells.<sup>73</sup> A multinational clinical trial using this new vector has recently started in Europe, with a US trial planned.

## GENE THERAPY FOR WAS

A clinical trial for WAS performed in Germany using a first-generation retroviral vector led to sustained engraftment and correction of WASp expression in lymphoid and myeloid cells and platelets in 9 out of 10 patients treated, resulting in improved immunologic and hematologic status. However, 7 of these 9 patients developed leukemia due to insertional mutagenesis, which makes this approach unacceptable.<sup>74,75</sup> Initial results from a trial for WAS using a lentiviral vector with the endogenous WAS gene promoter at San Raffaele Telethon Institute for Gene

Therapy in Milan, Italy, demonstrated good immune reconstitution, significant improvement in platelet numbers (although they remained subnormal) and no safety problems in the initial period of observation.<sup>76</sup> Another multicenter trial using the same vector but a slightly different conditioning regimen is under way in London, Paris and Boston.

## PERSPECTIVES FOR GENE THERAPY IN OTHER PRIMARY IMMUNE DEFICIENCIES

Other PIDs that are under extensive study and are subject, or will be subject, to gene therapy clinical trials include SCID due to RAG1, RAG2 or Artemis deficiency, LAD and HLH. Other PIDs that involve defects in cytokine and signaling pathway components, such as the JAK3 kinase and ZAP-70 kinase, CD40 ligand deficiency (X-linked hyper-IgM syndrome), IPEX, IL-7 receptor and XLA will require new approaches to gene therapy to achieve more sophisticated control of the expression of the responsible gene than occurs using constitutive promoters such as viral LTRs.

## NEW APPROACHES TO GENE THERAPY USING HEMATOPOIETIC STEM CELLS

Gene therapy for PIDs has progressed from an essentially ineffective method in the 1990s to its present status, where clear-cut efficacy has been achieved for several disorders, albeit with a risk for a significant degree of side-effects. Further advances will be based upon new insights into HSC biology and new methods for gene transfer. New understandings may eventually support efforts for ex vivo expansion of HSCs, which would allow the selective use of HSCs with favorable vector integration sites.

New major alternatives to the murine  $\gamma$ -retroviral vectors are vectors derived from lentiviruses or foamy viruses.<sup>77-79</sup> These latter types of retrovirus are of primate origin (HIV-1 lentiviruses from humans and the simian foamy virus from nonhuman primates) and are more efficient for transferring genes into human cells. These vectors can be made lacking the strong LTR enhancers that are problematic in the  $\gamma$ -retroviral vectors. Lentiviral vectors have entered clinical trials for T cells and CD34<sup>+</sup> HSCs and are likely to be applied to several PIDs and other genetic blood disorders in the near future.<sup>66,73,76,80-84</sup> A study in a canine model of LAD showed excellent clinical response using a foamy viral vector to transfer the relevant CD18 cDNA and may also be moving to the clinic.<sup>85</sup> Another important tactic being explored for added safety is the addition to vectors of 'insulator' sequences, which are DNA sequences that act as boundaries to prevent transcriptional cross-talk between adjacent genes in the chromosomes.<sup>86</sup>

## GENE CORRECTION

All of the gene therapy efforts discussed so far have involved the use of methods for *adding* a functional copy of a gene to cells (in a nonphysiologic chromosome location). A promising new approach to gene therapy under investigation seeks to *correct* the disease-causing mutation in a patient's own gene. Effective gene correction may have key advantages over gene addition. The corrected therapeutic gene would be in its normal location in the chromosomes, and so should be expressed in the normal developmental and quantitative pattern; this may be essential for safe and effective therapy of diseases due to defects

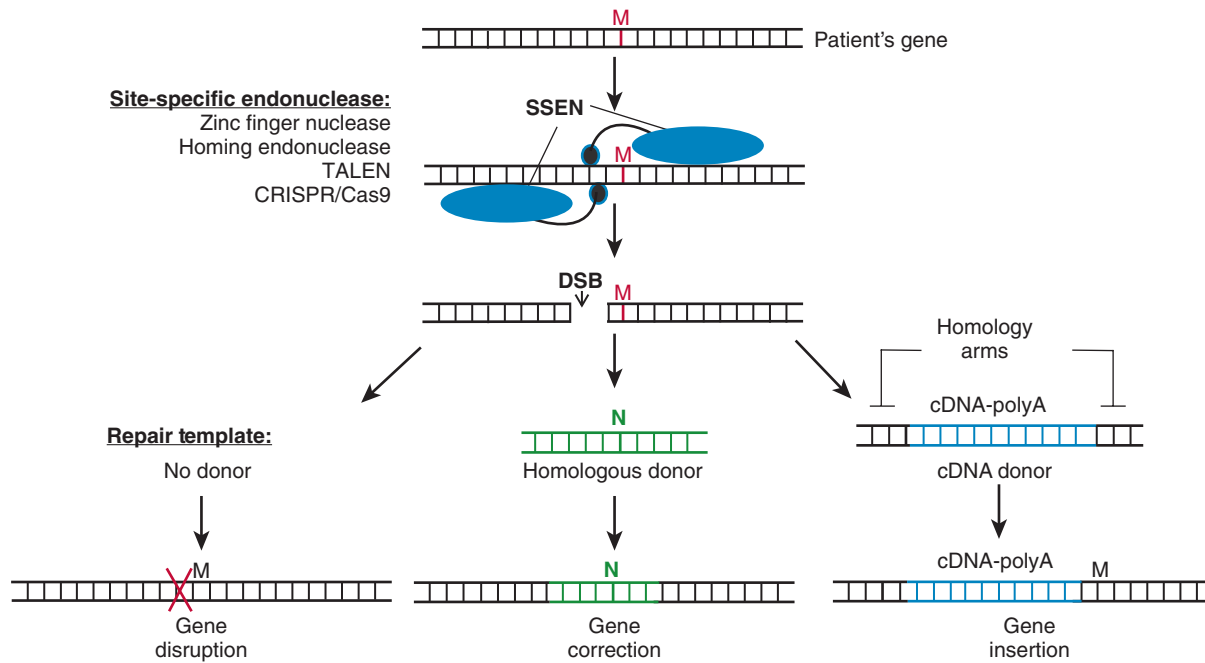
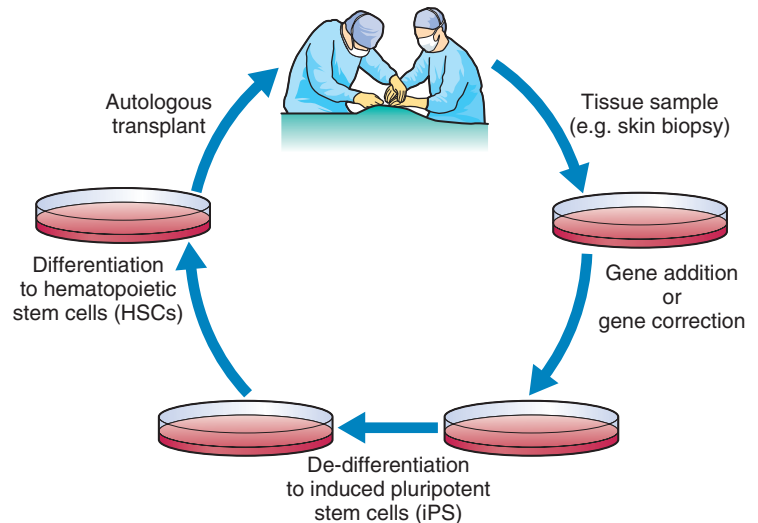

**Figure 16-3** Gene modification using site-specific endonucleases. For correcting a genetic mutation (red 'M'), site-specific endonucleases can be used to facilitate the repair process by producing a double-strand break (DSB) in the DNA near the mutation. The DSB may be resolved in several ways. If no donor is provided (left), non-homologous end joining may re-link the cut ends of the DNA, but often creates base-pair insertions or deletions, leading to gene disruption. If a homologous donor is introduced that contains the normal sequence (green 'N'; center), homology-driven repair may use the donor as a template to repair the DSB, copying the normal sequence into the genome for gene correction. If a donor is provided that contains the relevant cDNA with a polyadenylation signal flanked by homology arms to the sequence at the DSB (right), the cDNA-polyA signal may be copied into the DSB, leading to gene insertion.

in signaling proteins, including XLA, X-linked hyper-IgM syndrome and ZAP-70 kinase deficiency, as discussed above. Gene correction should avoid the problems of insertional oncogenesis from gene addition due to random insertion throughout the genome, resulting in activation of nearby genes.

Cells have multiple ways to repair damage to their chromosomal DNA, including homologous recombination (HR) that can lead to the genetic information on one strand being copied into a homologous, but nonidentical sequence (Figure 16-3). Flooding cells with high concentrations of nucleic acid sequences complementary to an endogenous gene sequence can cause the HR pathways to introduce corrective sequences into a cellular gene, for example to correct the single base-pair change in the human  $\beta$ -globin gene responsible for sickle cell disease.<sup>87</sup> However, early efforts to direct gene repair by HR were limited by very low efficiency. More recently, the efficiency of HR has been markedly improved by the use of transiently expressed site-specific endonucleases targeted to introduce double-stranded DNA breaks near the intended site of HR. A succession of such engineered nucleases (zinc-finger nucleases [ZFNs], homing endonucleases, TALENS and CRISPR/Cas9) can be designed to have DNA recognition domains that bind to unique sites in the genome and introduce a double-stranded break to induce HR, guided by a 'donor' oligonucleotide.<sup>88-90</sup> Gene correction by HR may be developed to achieve correction of the genes involved in PIDs.<sup>89,91</sup> It will need to be determined whether the efficacy and safety of gene correction provide a better therapeutic window than gene addition methods.

A future approach to gene therapy for these disorders may make use of the ability to 'reprogram' somatic cells to a pluripotent state (Figure 16-4). These induced pluripotent stem



**Figure 16-4** Gene therapy using autologous HSCs made from induced pluripotent stem cells. Somatic cells from a PID patient, such as skin fibroblasts or keratinocytes, can be obtained from a skin biopsy. These cells can be cultured and genetically corrected by gene addition or gene correction methods. The cells can then be de-differentiated to produce induced pluripotent stem cells (iPS). The iPS can then be directed to differentiate to HSCs that can be used to transplant the PID patient. The gene correction of the cultured somatic cells can be analyzed and selected for clones with complete appropriate gene correction and safe gene integration sites for use in the production of HSCs.

cells (iPS) could be produced from patient cells that are efficiently gene corrected in vitro. Then, the iPS could be directed to differentiate to HSCs for transplantation. This process has been demonstrated in a murine model of sickle cell disease, although several key steps have not been advanced to sufficient efficacy for human cells.<sup>92</sup>

## Conclusions

Although advances in supportive therapy and enzyme therapy have made improvements in the treatment of primary immune deficiencies, they are not curative for these life-threatening illnesses. HSCT and gene therapy provide the only curative options at this time. MSD HSCT remains the gold standard of treatment for many of these patients, but further data and experience have shown that closely matched unrelated bone marrow, peripheral blood stem cell and umbilical cord blood transplantation have satisfactory results in some of these disorders. HSCT

carries its own morbidities, some of which may be severe or even fatal, including GvHD, infections, toxicity associated with chemotherapy, and non-engraftment. Gene therapy utilizes autologous cells, so there is no risk for GvHD or graft rejection, and immune suppressive therapies are not needed. In addition, gene therapy may be successful and potentially have less toxicity due to the use of pretransplant conditioning regimens that are less than fully myeloablative and therefore less toxic. However, unexpected genotoxicity has occurred in some patients with the retroviral vectors used in previous trials.

Improvements in gene transfer to HSCs are under development that should increase clinical efficacy and decrease the risks. Furthermore, direct gene correction may offer advantages over gene addition, if sufficient efficiency can be achieved.

The complete reference list can be found on the companion Expert Consult website at <http://www.expertconsult.inkling.com>.

## KEY REFERENCES

16. Pai SY, Logan BR, Griffith LM, Buckley RH, Parrott RE, Dvorak CC, et al. Transplantation outcomes for severe combined immunodeficiency, 2000–2009. *N Engl J Med* 2014;371:434–46.
17. Hassan A, Booth C, Brightwell A, Allwood Z, Veys P, Rao K, et al. Outcome of hematopoietic stem cell transplantation for adenosine deaminase-deficient severe combined immunodeficiency. *Blood* 2012;120:3615–24.
18. Schuetz C, Neven B, Dvorak CC, Leroy S, Ege MJ, Pannicke U, et al. SCID patients with ARTEMIS vs RAG deficiencies following HCT: increased risk of late toxicity in ARTEMIS-deficient SCID. *Blood* 2014;123:281–9.
21. Moratto D, Giliani S, Bonfim C, Mazzolari E, Fischer A, Ochs HD, et al. Long-term outcome and lineage-specific chimerism in 194 patients with Wiskott-Aldrich syndrome treated by hematopoietic cell transplantation in the period 1980–2009: an international collaborative study. *Blood* 2011;118:1675–84.
30. Gungör T, Teira P, Slatter M, Stussi G, Stepensky P, Moshous D, et al. Reduced-intensity conditioning and HLA-matched haemopoietic stem-cell transplantation in patients with chronic granulomatous disease: a prospective multicentre study. *Lancet* 2014;383:436–48.
50. Aiuti A, Cattaneo F, Galimberti S, Benninghoff U, Cassani B, Callegaro L, et al. Gene therapy for immunodeficiency due to adenosine deaminase deficiency. *N Engl J Med* 2009;360:447–58.
55. Hacein-Bey-Abina S, Hauer J, Lim A, Picard C, Wang GP, Berry CC, et al. Efficacy of gene therapy for X-linked severe combined immunodeficiency. *N Engl J Med* 2010;363:355–64.
70. Ott MG, Schmidt M, Schwarzwaelder K, Stein S, Siler U, Koehl U, et al. Correction of X-linked chronic granulomatous disease by gene therapy, augmented by insertional activation of MDS1-EVI1, PRDM16 or SETBP1. *Nat Med* 2006;12:401–9.
76. Aiuti A, Biasco L, Scaramuzza S, Ferrua F, Cicalese MP, Baricordi C, et al. Lentiviral hematopoietic stem cell gene therapy in patients with Wiskott-Aldrich syndrome. *Science* 2013;341:1233151.
91. Genovese P, Schirolli G, Escobar G, Di Tomaso T, Firrito C, Calabria A, et al. Targeted genome editing in human repopulating haematopoietic stem cells. *Nature* 2014;510:235–40.



## REFERENCES

- Gatti RA, Meuwissen HJ, Allen HD, Hong R, Good RA. Immunological reconstitution of sex-linked lymphopenic immunological deficiency. *Lancet* 1968;2:1366–9.
- Dupont B, Andersen V, Ernst P, Faber V, Good RA, Hansen GS, et al. Immunologic reconstitution in severe combined immunodeficiency with HLA-incompatible bone marrow graft: donor selection by mixed lymphocyte culture. *Transplant Proc* 1973;5:905–8.
- Park BY, Biggar WD, Good RA. Transplantation of incompatible bone marrow in infants with severe combined immunodeficiency disease. *Birth Defects Orig Artic Ser* 1975;11:380–4.
- Blaese RM, Culver KW, Miller AD, Carter CS, Fleisher T, Clerici M, et al. T lymphocyte-directed gene therapy for ADA-SCID: initial trial results after 4 years. *Science* 1995;270:475–80.
- Bordignon C, Notarangelo LD, Nobili N, Ferrari G, Casorati G, Panina P, et al. Gene therapy in peripheral blood lymphocytes and bone marrow for ADA-immunodeficient patients. *Science* 1995;270:470–5.
- Cavazzana-Calvo M, Hacein-Bey S, de Saint Basile G, Gross F, Yvon E, Nusbaum P, et al. Gene therapy of human severe combined immunodeficiency (SCID)-X1 disease. *Science* 2000;288:669–72.
- Antoine C, Müller S, Cant A, Cavazzana-Calvo M, Veys P, Vossen J, et al. Long-term survival and transplantation of haemopoietic stem cells for immunodeficiencies: report of the European experience 1968–99. *Lancet* 2003;361:553–60.
- Buckley RH, Schiff SE, Schiff RI, Markert L, Williams LW, Roberts JL, et al. Hematopoietic stem-cell transplantation for the treatment of severe combined immunodeficiency. *N Engl J Med* 1999;340:508–16.
- Hacein-Bey-Abina S, Pai SY, Gaspar HB, Armand M, Berry CC, Blanche S, et al. A modified  $\gamma$ -retrovirus vector for X-linked severe combined immunodeficiency. *N Engl J Med* 2014;371:1407–17.
- Haddad E, Leroy S, Buckley RH. B-cell reconstitution for SCID: should a conditioning regimen be used in SCID treatment? *J Allergy Clin Immunol* 2013;131:994–1000.
- Titman P, Pink E, Skucek E, O'Hanlon K, Cole TJ, Gaspar J, et al. Cognitive and behavioral abnormalities in children after hematopoietic stem cell transplantation for severe congenital immunodeficiencies. *Blood* 2008;112:3907–13.
- Ozshahin H, Cavazzana-Calvo M, Notarangelo LD, Schulz A, Thrasher AJ, Mazzolari E, et al. Long-term outcome following hematopoietic stem-cell transplantation in Wiskott-Aldrich syndrome: collaborative study of the European Society for Immunodeficiencies and European Group for Blood and Marrow Transplantation. *Blood* 2008;111:439–45. Epub 2007 Sep 27.
- Grunebaum E, Mazzolari E, Porta F, Dalleria D, Atkinson A, Reid B, et al. Bone marrow transplantation for severe combined immune deficiency. *JAMA* 2006;295:508–18.
- Flomenberg N, Baxter-Lowe LA, Confer D, Fernandez-Vina M, Filipovich A, Horowitz M, et al. Impact of HLA class I and class II high-resolution matching on outcomes of unrelated donor bone marrow transplantation: HLA-C mismatching is associated with a strong adverse effect on transplantation outcome. *Blood* 2004;104:1923–30.
- Griffith LM, Cowan MJ, Notarangelo LD, Kohn DB, Puck JM, Pai SY, et al. Primary Immune Deficiency Treatment Consortium (PIDTC) report. *J Allergy Clin Immunol* 2014;133:335–47.
- Pai SY, Logan BR, Griffith LM, Buckley RH, Parrott RE, Dvorak CC, et al. Transplantation outcomes for severe combined immunodeficiency, 2000–2009. *N Engl J Med* 2014;371:434–46.
- Hassan A, Booth C, Brightwell A, Allwood Z, Veys P, Rao K, et al. Outcome of hematopoietic stem cell transplantation for adenosine deaminase-deficient severe combined immunodeficiency. *Blood* 2012;120:3615–24.
- Schuetz C, Neven B, Dvorak CC, Leroy S, Ege MJ, Pannicke U, et al. SCID patients with ARTEMIS vs RAG deficiencies following HCT: increased risk of late toxicity in ARTEMIS-deficient SCID. *Blood* 2014;123:281–9.
- Bach FH, Albertini RJ, Joo P, Anderson JL, Bortin MM. Bone marrow transplantation in a patient with the Wiskott-Aldrich syndrome. *Lancet* 1968;292:1364–6.
- Filipovich AH, Stone JV, Tomany SC, Ireland M, Kollman C, Pelz CJ, et al. Impact of donor type on outcome of bone marrow transplantation for Wiskott-Aldrich syndrome. *Blood* 2001;97:1598–603.
- Moratto D, Giliani S, Bonfim C, Mazzolari E, Fischer A, Ochs HD, et al. Long-term outcome and lineage-specific chimerism in 194 patients with Wiskott-Aldrich syndrome treated by hematopoietic cell transplantation in the period 1980–2009: an international collaborative study. *Blood* 2011;118:1675–84.
- Becker-Herman S, Meyer-Bahlburg A, Schwartz MA, Jackson SW, Hudkins KL, Liu C, et al. WASp-deficient B-cells play a critical, cell-intrinsic role in triggering autoimmunity. *J Exp Med* 2011;208:2033–42.
- Simon KL, Anderson SM, Garabedian EK, Moratto D, Sokolic RA, Candotti F. Molecular and phenotypic abnormalities of B lymphocytes in patients with Wiskott-Aldrich syndrome. *J Allergy Clin Immunol* 2014;133:896–9.
- Kuhns DB, Alvord WG, Heller T, Feld JJ, Pike KM, Marciano BE, et al. Residual NADPH oxidase and survival in chronic granulomatous disease. *N Engl J Med* 2010;363:2600–10.
- Winkelstein JA, Marino MC, Johnston RB Jr, Boyle J, Curnutte J, Gallin JI, et al. Chronic granulomatous disease: report on a national registry of 368 patients. *Medicine* 2000;79:155–69.
- Seger RA, Gungor T, Belohradsky BH, Blanche S, Bordignon P, Di Bartolomeo P, et al. Treatment of chronic granulomatous disease with myeloablative conditioning and an unmodified hemopoietic allograft: a survey of the European experience, 1985–2000. *Blood* 2002;100:4344–50.
- Bhattacharya A, Slatter M, Curtis A, Chapman CE, Barge D, Jackson A, et al. Successful umbilical cord blood stem cell transplantation for chronic granulomatous disease. *Bone Marrow Transplant* 2003;31:403–5.
- Parikh SH, Szabolcs P, Prasad VK, Lakshminarayanan S, Martin PL, Driscoll TA, et al. Correction of chronic granulomatous disease after second unrelated-donor umbilical cord blood transplantation. *Pediatr Blood Cancer* 2007;49:982–1046.
- Horwitz ME, Barrett AJ, Brown MR, Carter CS, Childs R, Gallin JI, et al. Treatment of chronic granulomatous disease with nonmyeloablative conditioning and a T-cell-depleted hematopoietic allograft. *N Engl J Med* 2001;344:881–8.
- Güngör T, Teira P, Slatter M, Stussi G, Stepensky P, Moshous D, et al. Reduced-intensity conditioning and HLA-matched haemopoietic stem-cell transplantation in patients with chronic granulomatous disease: a prospective multicentre study. *Lancet* 2014;383:436–48.
- Fischer A, Cerf-Bensussan N, Blanche S, Le Deist F, Bremond-Oury C, Leverger G, et al. Allogeneic bone marrow transplantation for erythrophagocytic lymphohistiocytosis. *J Pediatr* 1986;108:267–70.
- Henter JI, Samuelsson-Horne A, Aricò M, Egeler RM, Elinder G, Filipovich AH, et al. Treatment of hemophagocytic lymphohistiocytosis with HLH-94 immunochemotherapy and bone marrow transplantation. *Blood* 2002;100:2367–73.
- Henter JI, Horne A, Aricò M, Egeler RM, Filipovich AH, Imashuku S, et al. HLH-2004: diagnostic and therapeutic guidelines for hemophagocytic lymphohistiocytosis. *Pediatr Blood Cancer* 2007;48:124–31.
- Marsh RA, Vaughn G, Kim MO, Li D, Jodele S, Joshi S, et al. Reduced-intensity conditioning significantly improves survival of patients with hemophagocytic lymphohistiocytosis undergoing allogeneic hematopoietic cell transplantation. *Blood* 2010;116:5824–31.
- Giblett ER, Anderson JE, Cohen F, Pollara B, Meuwissen HJ. Adenosine deaminase deficiency in two patients with severely impaired cellular immunity. *Lancet* 1972;2:1067–9.
- Onodera M, Ariga T, Kawamura N, Kobayashi I, Ohtsu M, Yamada M, et al. Successful peripheral T lymphocyte-directed gene transfer for a patient with severe combined immune deficiency caused by adenosine deaminase deficiency. *Blood* 1998;91:30–6.
- Hoogerbrugge PM, van Beusechem VW, Fischer A, Debre M, le Deist F, Perignon JL, et al. Bone marrow gene transfer in three patients with adenosine deaminase deficiency. *Gene Ther* 1996;3:179–83.
- Kohn DB, Hershfield MS, Carbonaro D, Shigeoka A, Brooks J, Smogorzewska EM, et al. T lymphocytes with a normal ADA gene accumulate after transplantation of transduced autologous umbilical cord blood CD34+ cells in ADA-deficient SCID neonates. *Nat Med* 1998;4:775–80.
- Kohn DB, Weinberg KI, Nolte JA, Heiss LN, Lenarsky C, Crooks GM, et al. Engraftment of gene-modified umbilical cord blood cells in neonates with adenosine deaminase deficiency. *Nat Med* 1995;1:1017–23.
- Aiuti A, Vai S, Mortellaro A, Casorati G, Ficara F, Andolfi G, et al. Immune reconstitution in ADA-SCID after PBL gene therapy and discontinuation of enzyme replacement. *Nat Med* 2002;8:423–5.
- Muul LM, Tuschong LM, Soenen SL, Jagadeesh GJ, Ramsey WJ, Long Z, et al. Persistence and expression of the adenosine deaminase gene for 12 years and immune reaction to gene transfer components: long-term results of the first clinical gene therapy trial. *Blood* 2003;101:2563–9.

42. Miller AD, Garcia JV, von Suhr N, Lynch CM, Wilson C, Eiden MV. Construction and properties of retrovirus packaging cells based on gibbon ape leukemia virus. *J Virol* 1991;65:2220–4.
43. Moritz T, Patel VP, Williams DA. Bone marrow extracellular matrix molecules improve gene transfer into human hematopoietic cells via retroviral vectors. *J Clin Invest* 1994;93:1451–7.
44. Dao MA, Shah AJ, Crooks GM, Nolte JA. Engraftment and retroviral marking of CD34+ and CD34+CD38- human hematopoietic progenitors assessed in immune-deficient mice. *Blood* 1998;91:1243–55.
45. Kiem HP, McSweeney PA, Bruno B, Goerner M, Buron G, Morris J, et al. Improved gene transfer into canine hematopoietic repopulating cells using CD34-enriched marrow cells in combination with a gibbon ape leukemia virus-pseudotype retroviral vector. *Gene Ther* 1999;6:966–72.
46. Wu T, Kim HJ, Sellers SE, Meade KE, Agricola BA, Metzger ME, et al. Prolonged high-level detection of retrovirally marked hematopoietic cells in nonhuman primates after transduction of CD34+ progenitors using clinically feasible methods. *Mol Ther* 2000;1:285–93.
47. McSweeney PA, Storb R. Mixed chimerism: pre-clinical studies and clinical applications. *Biol Blood Marrow Transplant* 1999;5:192–203.
48. Carella AM, Champlin R, Slavin S, McSweeney P, Storb R. Mini-allografts: ongoing trials in humans. *Bone Marrow Transplant* 2000;25:345–50.
49. Aiuti A, Slavin S, Aker M, Ficara F, Deola S, Mortellaro A, et al. Correction of ADA-SCID by stem cell gene therapy combined with nonmyeloablative conditioning. *Science* 2002;296:2410–13.
50. Aiuti A, Cattaneo F, Galimberti S, Benninghoff U, Cassani B, Callegaro L, et al. Gene therapy for immunodeficiency due to adenosine deaminase deficiency. *N Engl J Med* 2009;360:447–58.
51. Gaspar HB, Cooray S, Gilmour KC, Parsley KL, Zhang F, Adams S, et al. Hematopoietic stem cell gene therapy for adenosine deaminase-deficient severe combined immunodeficiency leads to long-term immunological recovery and metabolic correction. *Sci Transl Med* 2011;3:97r80.
52. Candotti F, Shaw KL, Muul L, Carbonaro D, Sokolic R, Choi C, et al. Gene therapy for adenosine deaminase-deficient severe combined immunodeficiency: clinical comparison of retroviral vectors and treatment plans. *Blood* 2012;120:3635–46.
53. Fischer A, Hacein-Bey-Abina S, Cavazzana-Calvo M. Gene therapy of primary T-cell immunodeficiencies. *Gene* 2013;525:170–3.
54. Gaspar HB, Parsley KL, Howe S, King D, Gilmour KC, Sinclair J, et al. Gene therapy of X-linked severe combined immunodeficiency by use of a pseudotyped gamma-retroviral vector. *Lancet* 2004;364:2181–7.
55. Hacein-Bey-Abina S, Hauer J, Lim A, Picard C, Wang GP, Berry CC, et al. Efficacy of gene therapy for X-linked severe combined immunodeficiency. *N Engl J Med* 2010;363:355–64.
56. Gaspar HB, Cooray S, Gilmour KC, Parsley KL, Adams S, Howe SJ, et al. Long-term persistence of a polyclonal T-cell repertoire after gene therapy for X-linked severe combined immunodeficiency. *Sci Transl Med* 2011;3:97ra79.
57. Hacein-Bey-Abina S, von Kalle C, Schmidt M, Le Deist F, Wulfraat N, McIntyre E, et al. A serious adverse event after successful gene therapy for X-linked severe combined immunodeficiency. *N Engl J Med* 2003;348:255–6.
58. Hacein-Bey-Abina S, Von Kalle C, Schmidt M, McCormack MP, Wulfraat N, Leboulch P, et al. LMO2-associated clonal T-cell proliferations in two patients after gene therapy for SCID-X1. *Science* 2003;302:415–19.
59. Howe SJ, Mansour MR, Schwarzwaelder K, Bartholomae C, Hubank M, Kempinski H, et al. Insertional mutagenesis combined with acquired somatic mutations causes leukemogenesis following gene therapy of SCID-X1 patients. *J Clin Invest* 2008;118:3143–50.
60. Woods NB, Bottero V, Schmidt M, von Kalle C, Verma IM. Gene therapy: therapeutic gene causing lymphoma. *Nature* 2006;440:1123.
61. Sokolic R, Maric I, Kesserwan C, Garabedian E, Hanson IC, Dodds M, et al. Myeloid dysplasia and bone marrow hypocellularity in adenosine deaminase-deficient severe combined immunodeficiency. *Blood* 2011;118:2688–94.
62. Thrasher AJ, Hacein-Bey-Abina S, Gaspar HB, Blanche S, Davies EG, Parsley K, et al. Failure of SCID-X1 gene therapy in older patients. *Blood* 2005;105:4255–7.
63. Chinen J, Davis J, De Ravin SS, Hay BN, Hsu AP, Linton GF, et al. Gene therapy improves immune function in preadolescents with X-linked severe combined immunodeficiency. *Blood* 2007;110:67–73.
64. Shaw KL, Kohn DB. A tale of two SCIDs. *Sci Transl Med* 2011;3:97ps36.
65. De Ravin SS, Moir S, Theobald N, Lee J, Wu X, Choi U, et al. Lentivector gene therapy with non-myeloablative conditioning restores IgG production in young adults with SCID-X1. *Mol Ther* 2014;22(Suppl. 1):S106.
66. Dinauer MC, Li LL, Björgvinsdóttir H, Ding C, Pech N. Long-term correction of phagocyte NADPH oxidase activity by retroviral-mediated gene transfer in murine X-linked chronic granulomatous disease. *Blood* 1999;94:914–22.
67. Mardiney M 3rd, Jackson SH, Spratt SK, Li F, Holland SM, Malech HL. Enhanced host defense after gene transfer in the murine p47phox-deficient model of chronic granulomatous disease. *Blood* 1997;89:2268–75.
68. Malech HL, Maples PB, Whiting-Theobald N, Linton GF, Sekhsaria S, Vowells SJ, et al. Prolonged production of NADPH oxidase-corrected granulocytes after gene therapy of chronic granulomatous disease. *Proc Natl Acad Sci U S A* 1997;94:12133–8.
69. Kang EM, Choi U, Theobald N, Linton G, Long Priel DA, Kuhns D, et al. Retrovirus gene therapy for X-linked chronic granulomatous disease can achieve stable long-term correction of oxidase activity in peripheral blood neutrophils. *Blood* 2010;115:783–91.
70. Ott MG, Schmidt M, Schwarzwaelder K, Stein S, Siler U, Koehl U, et al. Correction of X-linked chronic granulomatous disease by gene therapy, augmented by insertional activation of MDS1-EV11, PRDM16 or SETBP1. *Nat Med* 2006;12:401–9.
71. Stein S, Ott MG, Schultze-Strasser S, Jauch A, Burwinkel B, Kinner A, et al. Genomic instability and myelodysplasia with monosomy 7 consequent to EV11 activation after gene therapy for chronic granulomatous disease. *Nat Med* 2010;16:198–204.
72. Celander D, Haseltine WA. Tissue-specific transcription preference as a determinant of cell tropism and leukaemogenic potential of murine retroviruses. *Nature* 1984;312:159–62.
73. Santilli G, Almarza E, Brendel C, Choi U, Beilin C, Blundell MP, et al. Biochemical correction of X-CGD by a novel chimeric promoter regulating high levels of transgene expression in myeloid cells. *Mol Ther* 2011;19:122–32.
74. Boztug K, Schmidt M, Schwarzer A, Banerjee PP, Diez IA, Dewey RA, et al. Stem-cell gene therapy for the Wiskott-Aldrich syndrome. *N Engl J Med* 2010;363:1918–27.
75. Braun CJ, Boztug K, Paruzynski A, Witzel M, Schwarzer A, Rothe M, et al. Gene therapy for Wiskott-Aldrich syndrome – long-term efficacy and genotoxicity. *Sci Transl Med* 2014;6:227ra33.
76. Aiuti A, Biasco L, Scaramuzza S, Ferrua F, Cicalese MP, Baricordi C, et al. Lentiviral hematopoietic stem cell gene therapy in patients with Wiskott-Aldrich syndrome. *Science* 2013;341:1233151.
77. Naldini L, Blömer U, Gally P, Ory D, Mulligan R, Gage FH, et al. In vivo gene delivery and stable transduction of nondividing cells by a lentiviral vector. *Science* 1996;272:263–7.
78. Naldini L. Lentiviruses as gene transfer agents for delivery to non-dividing cells. *Curr Opin Biotechnol* 1998;9:457–63.
79. Hirata RK, Miller AD, Andrews RG, Russell DW. Transduction of hematopoietic cells by foamy virus vectors. *Blood* 1996;88:3654–61.
80. Cartier N, Hacein-Bey-Abina S, Bartholomae CC, Veres G, Schmidt M, Kutschera I, et al. Hematopoietic stem cell gene therapy with a lentiviral vector in X-linked adrenoleukodystrophy. *Science* 2009;326:818–23.
81. Cavazzana-Calvo M, Payen E, Negre O, Wang G, Hehir K, Fusil F, et al. Transfusion independence and HMGA2 activation after gene therapy of human  $\beta$ -thalassaemia. *Nature* 2010;467:318–22.
82. Biffi A, Montini E, Lorioli L, Cesani M, Fumagalli F, Plati T, et al. Lentiviral hematopoietic stem cell gene therapy benefits metachromatic leukodystrophy. *Science* 2013;341:1233158.
83. Zhou S, Mody D, DeRavin SS, Hauer J, Lu T, Ma Z, et al. A self-inactivating lentiviral vector for SCID-X1 gene therapy that does not activate LMO2 expression in human T-cells. *Blood* 2010;116:900–8.
84. Carbonaro DA, Zhang L, Jin X, Montiel-Equihua C, Geiger S, Carmo M, et al. Preclinical demonstration of lentiviral vector-mediated correction of immunological and metabolic abnormalities in models of adenosine deaminase deficiency. *Mol Ther* 2014;22:607–22.
85. Bauer TR Jr, Allen JM, Hai M, Tuschong LM, Khan IF, Olson EM, et al. Successful treatment of canine leukocyte adhesion deficiency by foamy virus vectors. *Nat Med* 2008;14:93–7.
86. Emery DW. The use of chromatin insulators to improve the expression and safety of integrating gene transfer vectors. *Hum Gene Ther* 2011;22:761–74.
87. Goncz KK, Prokopishyn NL, Abdolmohammadi A, Bedayat B, Maurisse R, Davis BR, et al. Small fragment homologous replacement-mediated modification of genomic beta-globin sequences in human hematopoietic stem/progenitor cells. *Oligonucleotides* 2006;16:213–24.
88. Urnov FD, Miller JC, Lee YL, Beausejour CM, Rock JM, Augustus S, et al. Highly efficient endogenous human gene correction using designed zinc-finger nucleases. *Nature* 2005;435:646–51.

89. Lombardo A, Genovese P, Beausejour CM, Colleoni S, Lee YL, Kim KA, et al. Gene editing in human stem cells using zinc finger nucleases and integrase-defective lentiviral vector delivery. *Nat Biotechnol* 2007;25:1298–306.
90. Tebas P, Stein D, Tang WW, Frank I, Wang SQ, Lee G, et al. Gene editing of CCR5 in autologous CD4 T-cells of persons infected with HIV. *N Engl J Med* 2014;370:901–10.
91. Genovese P, Schirolli G, Escobar G, Di Tomaso T, Firrito C, Calabria A, et al. Targeted genome editing in human repopulating haematopoietic stem cells. *Nature* 2014;510:235–40.
92. Hanna J, Wernig M, Markoulaki S, Sun CW, Meissner A, Cassady JP, et al. Treatment of sickle cell anemia mouse model with iPS cells generated from autologous skin. *Science* 2007;318:1920–3.

# Biologic Therapies

ROBERT EISENBERG | EDWARD M. BEHRENS

## KEY POINTS

- Biologics are mostly large molecules, usually proteins, that serve as therapeutics and are derived from living organisms.
- Biologics produced in vitro by recombinant technology are monoclonal antibodies, soluble receptor constructs, or cytokines. The first two categories are discussed in this chapter.
- Recombinant biologics bind their target with high affinity, and have reduced potential for off-target effects compared to small molecule agents.
- Safety concerns with biologics arise from their effectiveness in targeting physiologic molecules or cells, or from their ability to elicit an immune response against the drug itself.
- The molecular complexity and unavoidable heterogeneity of recombinant biologics make them expensive to produce and impossible to copy exactly in a generic form. In the future, biosimilars will be produced that mimic an existing approved biologic as far as possible.

Biologics are drugs that are derived from living organisms. In the broadest sense, this category encompasses any agent made by biological processes, including recombinant therapeutic proteins, as well as blood, blood products, proteins or other molecules purified from living material, such as IVIG (see Chapter 15), cells and gene therapies (Chapter 16), allergens (Chapter 23) and vaccines. We discuss in this chapter therapeutic proteins that are monoclonal antibodies or soluble receptor constructs. They have all been developed by genetic engineering, and they are produced in vitro in large cultures of prokaryotic or eukaryotic cells. Therapeutic cytokines manufactured by recombinant technology comprise another increasingly important subset of biologics. They are listed in [Table 17-1](#) but will not be further described here.

The fundamental therapeutic rationale underlying the biologics discussed in this chapter relates to the exquisite specificity of the humoral immune system's antibodies or of certain physiologic receptor-ligand interactions, coupled with the identification of molecules or cells that are critical to the pathologic processes of disease. This permits the development of agents that will target selected steps in a disease pathway with very high affinity yet have little propensity to have 'off-target' interactions that could lead to serious side-effects. In addition to their specificity, many of the biologics closely resemble physiologic molecules, and as such, they may be administered in large quantities to achieve the substantial levels (hundreds of micrograms per

mL) that can potentially block all of their targets in vivo. This pharmacodynamic efficiency of the biologics certainly accounts for their impressive efficacy in many uses. It also implies that the failure of a particular biologic to provide therapeutic benefit in a given situation makes it unlikely that the targeted molecule plays a non-redundant role in the disease process.

The complex nature of biologics in part accounts for their high cost, which limits their general use, particularly in developing countries. It also presents several other potential problems particular to this group of drugs. Their molecular complexity makes them relatively difficult to develop and often entails a degree of structural heterogeneity that may have unintended consequences.<sup>15</sup> Any change in the manufacturing process must be assumed to change the final product to some extent. This makes the generation of generic forms of biologics essentially impossible. So-called 'biosimilars' can have the same amino acid sequence as the first-approved biologic, but the post-translational modifications will not be identical.<sup>16,17</sup> This variability demands that the regulatory requirements for approval must go beyond any demonstration of chemical identity and should include some biological measures of equivalence in pharmacokinetics, pharmacodynamics, clinical efficacy and safety. Such requirements would need to be less stringent than those applied to a new compound, or the potential financial benefit of the biosimilar (i.e. lower patient cost) would be abrogated. Biosimilar mimics of the compounds discussed in detail in this chapter have not yet appeared in the US market, and the path to approval will have to be developed individually in each case. Compounds that have the same targets but are independently developed (e.g. adalimumab and infliximab), are of course not biosimilars, and each has to undergo its own extensive developmental process. Nevertheless, the success and failures of a given compound will help guide the clinical development of others with the same target. In addition, the safety concerns that the US Food and Drug Administration (FDA) requires in the package inserts may reflect analogies with other compounds with the same target, even in the absence of adverse event data that are directly relevant.

Another general concern about biologics is immunogenicity. As large protein molecules, these drugs are potentially good immunogens. Most of the receptor constructs, such as rilona-cept, are different from any autologous protein in the overall structure (anakinra is the exception), although they are made up of faithful portions of individual physiologic molecules. The monoclonal antibodies are more physiologic, but they also can provoke immune responses. Muromonab-CD3, the first monoclonal antibody approved in the USA in 1986, was derived from a mouse immunized with human T cells.<sup>18,19</sup> It recognizes the CD3ε subunit of the T cell receptor-CD3 complex, and it is effective in treating allograft rejection. However, it frequently induces anti-mouse IgG antibodies (termed HAMA, or human



**TABLE 17-1** Biologics Approved in Children, Recombinant Cytokines

Compound	Brand Name, Manufacturer	Pediatric Indications	Age Restriction
C1 esterase inhibitor	Cinryze <sup>®</sup>	Hereditary angioedema <sup>1,2</sup>	Adolescents
Epoetin alfa	Epogen <sup>®</sup>	Anemia <sup>3</sup>	None
Filgrastim (G-CSF)	Neupogen <sup>®</sup>	Neutropenia <sup>4,5</sup>	None
Interferon alfa-2b	Intron <sup>®</sup> A	Chronic hepatitis B <sup>6</sup>	≥ 1 yr
Interferon gamma	Actimmune <sup>®</sup>	Chronic granulomatous disease, osteopetrosis <sup>7,8</sup>	None
Peginterferon alfa-2a	Pegasys <sup>®</sup>	Chronic hepatitis C <sup>9-11</sup>	≥ 5 yr
Peginterferon alfa-2b	Pegintron <sup>®</sup>	Chronic hepatitis C <sup>12,13</sup>	≥ 3 yr
Sargramostim	Leukine <sup>®</sup>	Bone marrow transplantation, chemotherapy <sup>14</sup>	None

\*These compounds are not discussed in detail in the text.

anti-mouse antibodies), which is part of the reason it was withdrawn from the market in 2010. Some murine monoclonal antibodies are still used clinically (e.g. ibritumomab in adults)<sup>20</sup> for short courses of therapy, but in general, further genetic modifications are undertaken to render the monoclonal more human and thus, less immunogenic.

A monoclonal antibody is usually selected from a mouse immunized with the appropriate human cells or protein. The variable regions of both the light and heavy chains are then joined, respectively, to the constant region domains of human  $\kappa$  or  $\lambda$ , and IgG (IgG1, IgG2 or IgG4) to make a chimeric molecule that is about two thirds of human origin. Infliximab is an example. Such proteins can still not infrequently induce antibody responses, termed HACA, or human anti-chimera antibodies. Further humanization can be obtained by substituting the framework regions in the variable domains with human framework sequences. This leaves only the complementarity determining regions (hypervariable regions) from the original mouse monoclonal. These are the sequences that determine the antigen-binding site, so the specificity of the engineered monoclonal remains the same, but it now has only about 10% mouse sequences. An example of such a humanized monoclonal is eculizumab.

A fully human monoclonal antibody can be produced in two ways. In one approach, a mouse is used in which the immunoglobulin genes have been replaced with human genes. This mouse then makes antibody responses that use human antibody sequences. Canakinumab was produced in this way. A second approach uses a bacteriophage display library of human variable region sequences and selects for antigen binding in vitro. The selected genes are then combined with human constant region genes to reconstitute a complete IgG antibody. Adalimumab was derived in this manner. Notwithstanding, these human monoclonals can provoke immune responses (termed HAHA, or human anti-human antibody), probably largely akin to anti-idiotypic responses that are themselves specific for the reagents' complementarity determining regions. Table 17-2 describes how the mouse/human composition of the monoclonal antibody produced is reflected in the spelling of the penultimate and antepenultimate syllables of its common name.

The immune responses to biologic agents that are often seen in a significant minority of patients may hasten the clearance of the drug, decrease its effectiveness or result in adverse reactions such as hypersensitivity. In many cases, however, they do not seem to have apparent clinical significance, and their

**TABLE 17-2** Nomenclature of the Biologics, Based on Structure

- Ultimate syllable:
    - '-mab' = monoclonal antibody, e.g. basiliximab
    - '-cept' = receptor fusion protein, e.g. alefacept
  - Penultimate syllable before 'mab':
    - '-xi-' = chimeric (mouse or rat origin immunoglobulin variable regions; human constant regions)
    - '-zu-' = humanized (chimeric monoclonal antibody genetically engineered, so that the variable region sequences outside the complementarity determining regions [i.e. combining site] are human)
    - '-u-' = fully human (selected from an in vitro human phage display library or from a mouse engineered to have human immunoglobulin genes)
    - '-mo-' = murine
  - Antepenultimate syllable:
    - '-li-' or '-lim-' = immune system (not consistently used)
- Thus:**  
**chimeric** human/mouse antibodies are **ximabs**, e.g. infliximab  
**humanized** antibodies are **zumabs**, e.g. alemtuzumab  
**fully human** antibodies are **umabs**, e.g. adalimumab  
**murine** antibodies are **momabs**, e.g. ibritumomab

\*Reproduced from: Stiehm's *Immune Deficiencies*, Edited by KE Sullivan and ER Stiehm, Elsevier, Amsterdam, 2014, page 891.

presence is not assayed in routine clinical care. In the early studies with infliximab, it was found that higher doses of drug, or giving it along with methotrexate, decreased the incidence of HACA formation.<sup>21</sup> It is not known how well this paradigm may extend to other compounds.

Another class of adverse reactions to the biologics comes from their therapeutic potency. Although they are unlikely to have 'off-target' side-effects, they are often so thorough in inhibiting their target that the normal physiologic functions of that target are blocked. Thus, the anti-TNF agents can reactivate latent mycobacterial infections in a characteristic way,<sup>22</sup> or eculizumab (anti-C5) can put patients at risk for serious infections with Gram-negative cocci by blocking the terminal complement cascade.<sup>23</sup>

The compounds discussed below are biologic monoclonal antibodies or receptor constructs that have an FDA-indicated use in the pediatric population as of mid-2014 (see Table 17-3). Other biologics approved only for adults have found common use in children. Some of them are listed in Table 17-4, but they will not be further discussed here.

**TABLE 17-3** Biologics Approved for Children: Monoclonal Antibodies and Soluble Receptor Constructs

Compound	Target	Pediatric Indications	Age Restrictions	FDA Approval <sup>†</sup>
Abatacept	CD80, CD86	Juvenile idiopathic arthritis	≥ 6 yr	2008
Adalimumab	TNF- $\alpha$	Juvenile idiopathic arthritis	≥ 4 yr	2008
Anakinra	IL-1R	Neonatal onset multisystem inflammatory disease	None	2014
Basiliximab	CD25	Renal transplantation	None	2001
Canakinumab	IL-1 $\beta$	Familial cold autoinflammatory syndrome, Muckle-Wells syndrome, SJA	CAPS ≥ 4 yr; SJA ≥ 2 yr	2009
Denosumab	RANKL	Giant cell tumor	Bone-mature adolescents	2013
Ecaltantide	Kallikrein	Hereditary angioedema	≥ 12 yr	2009
Eculizumab	C5	Atypical hemolytic uremic syndrome	None	2009
Etanercept	TNF- $\alpha$ , TNF- $\beta$	Juvenile idiopathic arthritis	> 2 yr	1999
Infliximab	TNF- $\alpha$	Inflammatory bowel disease	≥ 6 yr	2006
Omalizumab	IgE	Asthma, chronic idiopathic urticaria	≥ 12 yr	2003
Palivizumab	RSV F protein	RSV prevention	≤ 24 months	1998
Raxibacumab	Anthrax toxin	Anthrax	None	2012
Rilonacept	IL-1 $\beta$	Familial cold autoinflammatory syndrome, Muckle-Wells syndrome	≥ 12 yr	2008
Tocilizumab	IL-6R	Polyarticular and systemic juvenile idiopathic arthritis	≥ 2 yr	2011

\*These compounds are discussed in more detail in the text.

<sup>†</sup>Year that FDA approval was first granted for a pediatric indication.

SJA – Systemic juvenile idiopathic arthritis, CAPS – cryopyrin-associated periodic syndromes, RANKL – receptor activator of nuclear factor  $\kappa$  B ligand, RSV – respiratory syncytial virus.

**TABLE 17-4** Biologics not Approved in Children, but Commonly Used Off-Label

Compound	Brand Name	Target	Pediatric Uses
Abciximab	ReoPro <sup>®</sup>	GpIIb/IIIa receptor	Kawasaki disease <sup>24,25</sup>
Alemtuzumab	Campath <sup>®</sup>	CD52	Hemophagocytic lymphohistiocytosis <sup>26,27</sup>
Belimumab	Benlysta <sup>®</sup>	BLyS	SLE <sup>28</sup>
Bevacizumab	Avastin <sup>®</sup>	VEGF-A	Retinopathy of prematurity, malignancies <sup>29,30</sup>
Golimumab	Simponi <sup>®</sup>	TNF- $\alpha$	Juvenile idiopathic arthritis, uveitis <sup>31,32</sup>
Natalizumab	Tysabri <sup>®</sup>	$\alpha$ 4 integrin subunit	Multiple sclerosis <sup>33</sup>
Rituximab	Rituxan <sup>®</sup>	CD20	SLE, transplant, lymphoma/leukemia, others <sup>34,35</sup>
Ustekinumab	Stelara <sup>®</sup>	IL-12, IL-23	Psoriasis <sup>36</sup>

\*These compounds are not discussed in detail in the text. They are all the subject of ongoing (2014) clinical trials in children for the indicated uses, except abciximab, which is listed as being studied only for sickle cell crisis in children (<http://www.clinicaltrials.gov>).

BLyS – B lymphocyte stimulator, SLE – systemic lupus erythematosus, VEGF-A – vascular endothelial growth factor A.

## Biologics Approved for Pediatric Therapeutic Use

**Abatacept (Orencia<sup>®</sup>).** Abatacept is a soluble receptor mimic that consists of the extracellular domain of CTLA-4 (cytotoxic T lymphocyte antigen-4) linked to the Fc fragment of human IgG1.<sup>37</sup> It is produced in vitro from a chimeric gene construct. CTLA-4 is found on activated CD4 and CD8 T cells, and it mediates an inhibitory signal through ligation to CD80 or CD86.<sup>38</sup> However, the mechanism of action of abatacept results from its high-affinity binding to CD80 and CD86, which thereby prevents their interaction with the costimulatory molecule CD28, which is in turn constitutively expressed on CD4 and CD8 T cells. It was initially approved for use in adult rheumatoid arthritis in 2005. The pediatric indication for children 6 to 17 years old with juvenile idiopathic arthritis was added in 2008 on the basis of a 6-month withdrawal trial using 122 patients with polyarticular disease.<sup>39</sup> These patients were also found to

benefit in a longer-term open-label follow-up.<sup>40</sup> Abatacept is administered intravenously once a month, either as monotherapy or in conjunction with methotrexate. A preparation for subcutaneous self-administration is available only for adult use. Infections are a potential complication with abatacept therapy, although in general the risk may be less than with other biologics used for inflammatory arthritis.<sup>41–43</sup> Hepatitis B reactivation, however, may be a particular concern.<sup>44,45</sup>

**Adalimumab (Humira<sup>®</sup>).** Adalimumab is a fully human recombinant monoclonal antibody that binds the soluble and cell-bound forms of TNF- $\alpha$ . It was initially approved for adult rheumatoid arthritis in 2002.<sup>46</sup> An indication for juvenile idiopathic arthritis in children at least 4 years old was added in 2008 on the basis of a 32-week withdrawal study of 128 patients with polyarticular disease.<sup>47</sup> It is administered in weekly or biweekly subcutaneous doses, either as monotherapy or in combination with methotrexate. In adults (18 years and older), it is also

approved for use in ankylosing spondylitis, inflammatory bowel disease and psoriasis. Safety concerns for adalimumab are similar to those for the other biologics that target TNF- $\alpha$  and include bacterial, fungal and viral infections, malignancies, heart failure and the development of lupus- or multiple sclerosis-like syndromes.<sup>48,49</sup> In adults with rheumatoid arthritis, the presence of anti-adalimumab antibodies, found in about one quarter of treated patients, was associated with decreased efficacy and possibly increased adverse events.<sup>50,51</sup>

**Anakinra (Kineret®).** Anakinra is a recombinant form of the physiologic human protein interleukin-1 receptor antagonist (IL-1Ra).<sup>52</sup> It is structurally modified from the natural molecule, in that it lacks glycosylation and it has a methionine residue added to the amino terminus. It binds the IL-1 type 1 receptor without causing signaling and thereby prevents activation by the agonistic ligands IL-1 $\alpha$  and IL-1 $\beta$ . In 2001, it was approved for treatment of adults with rheumatoid arthritis.<sup>53</sup> Subsequently, based on the remarkable levels of serum IL-1 found in cryopyrin-associated autoinflammatory syndromes (CAPS), anakinra was tested in an open-label uncontrolled trial of 43 neonatal-onset multisystem inflammatory disease (NOMID) patients of varying ages.<sup>54–56</sup> All patients improved, and a subset relapsed upon withdrawal of the medication. Both the acute attacks and the progression of irreversible organ damage were inhibited. These findings led to the approval of NOMID as an additional indication for anakinra in 2014. Although anakinra has shown some evidence for efficacy in systemic juvenile idiopathic arthritis (SJIA), and is used in practice for this condition, it does not have FDA approval for this indication.<sup>57–58</sup> Anakinra has a relatively short in vivo half-life (4–6 hours), and must be given daily by subcutaneous injection. The main safety concern has been an increased susceptibility to infection.

**Basiliximab (Simulect®).** Basiliximab is a mouse/human chimeric monoclonal antibody specific for the  $\alpha$  chain of the high-affinity IL-2 receptor (CD25).<sup>59</sup> By blocking the cytokine IL-2 from binding to its receptor, basiliximab inhibits the activation of T lymphocytes. It is therefore effective for the prevention of acute rejection after renal transplantation. It was approved for this use in adults in 1998.<sup>60–61</sup> Although only open-label studies have been documented in pediatric patients, an explicit indication for use in this population was added by the FDA in 2001.<sup>62–63</sup> It is approved for use with an immunosuppressive regimen including cyclosporine and corticosteroids. It is administered as a single intravenous dose 2 hours before transplantation, and a second dose 4 days later. Infections are a prominent complication in this highly immunosuppressed patient group; however, the contribution of basiliximab per se to these adverse events is not clear.<sup>61,64</sup> Anaphylaxis-like immediate hypersensitivity reactions have been reported in post-marketing surveillance.<sup>65,66</sup>

**Canakinumab (Ilaris®).** Canakinumab is a fully human recombinant monoclonal antibody specific for IL-1 $\beta$ . It therefore blocks the binding of this cytokine to its receptor. It received a priority review approval in 2009 for use in two CAPS – familial cold autoinflammatory syndrome (FCAS) and Muckle-Wells syndrome (MWS) – in patients  $\geq$  4 years of age. Supporting data came from an international double-blind, placebo controlled 24-week withdrawal study of 35 patients,<sup>67</sup> and from uncontrolled experience with an additional 69 patients

(including 23 pediatric patients overall). Strikingly, 97% of patients in the controlled study had a complete response by day 29 of the open-label treatment phase. During the withdrawal period, none of the active drug-treated patients relapsed, while 81% in the placebo arm had a disease flare. In 2013, canakinumab received approval for the additional indication of SJIA in children  $\geq$  2 years of age, based on a 29-day double-blind, placebo-controlled trial of 84 patients, and a double-blind, placebo-controlled withdrawal trial of 100 patients over up to two years of treatment.<sup>68</sup> Although these trials indicated clinical efficacy, the magnitude of the effect was not nearly as impressive as for the CAPS trials. Canakinumab is administered subcutaneously every 8 weeks for CAPS and every 4 weeks for SJIA. The most important safety concern has been serious infections.

**Denosumab (Xgeva®).** Denosumab is a fully human recombinant monoclonal antibody specific for RANKL (receptor activator of NF- $\kappa$ B ligand). It blocks the binding of this ligand with RANK on pre-osteoclasts and thereby prevents their maturation into osteoclasts.<sup>69–72</sup> It thus favors bone formation over bone resorption. Animal studies have indicated that denosumab can interfere with bone development, so its pediatric use, approved in 2013, has been restricted to skeletally mature adolescents with giant cell tumors of the bone.<sup>72</sup> Two open-label, uncontrolled trials provided evidence of efficacy. In the first trial in 37 adults, 30 were considered to have responded by either histologic or radiologic criteria.<sup>73</sup> In a second trial of 282 patients, including 10 adolescents (13–17 years old), almost no disease progression was seen with a median follow-up of 9 to 13 months, and about half the patients were considered to have a complete or partial tumor response (an exploratory outcome in this phase II study).<sup>74,75</sup> However, an independent review of the data in the two trials concluded that only 25% of patients, including two of the six evaluable adolescents, showed a partial response (Xgeva® package insert). For treatment of giant cell tumors, denosumab is administered subcutaneously on days 1, 8, 15 and 30, and then monthly. The major safety concerns have been hypocalcemia and osteonecrosis. Note that denosumab is also marketed for treatment of osteopenia/osteoporosis under a separate brand name (Prolia®), without a pediatric indication.

**Ecallantide (Kalbitor®).** Ecallantide is a 7,000 kDa protein that binds to the active site of kallikrein and thereby blocks the conversion of high molecular weight kininogen to bradykinin. Its structure is based on the first Kunitz domain (active site) of human tissue factor inhibitor (also known as lipoprotein associate coagulation inhibitor). It was selected by phage display to bind kallikrein with high affinity, and it is produced in yeast by recombinant technology.<sup>76,77</sup> It was approved in 2009 for the treatment of acute episodes of hereditary angioedema (HAE) due to C1 esterase deficiency or dysfunction, based on two randomized, double-blind controlled trials in a total of 143 HAE patients  $\geq$  10 years old.<sup>78–82</sup> Not surprisingly, most of the enrolled patients in these trials were adults, and the pediatric population was skewed toward the older ages. Thus, the original labeling was for patients  $\geq$  16 years old; in 2014, the FDA extended the labeling to include adolescents  $\geq$  12 years old. The pivotal studies, which were single dose, did not report drug-related serious adverse events, but the package labeling, which includes experience in retreated patients, cites a 4% incidence of anaphylaxis.<sup>83,84</sup> This complication has not been specifically

seen in the published pediatric experience, but the number of individuals < 18 years old analyzed is relatively small ( $N = 29$ ).<sup>82</sup>

**Ecuzumab (Soliris®).** Ecuzumab is a humanized recombinant monoclonal antibody that binds the C5 complement component and prevents its activation by cleavage.<sup>85</sup> This blocks the release of the inflammatory C5a fragment and prevents the subsequent initiation of the terminal complement cascade (C5b–C9). It was approved in 2007 for the treatment of adults with paroxysmal nocturnal hemoglobinuria (PNH).<sup>86</sup> In 2009, ecuzumab received an accelerated approval for treatment of atypical hemolytic uremic syndrome (aHUS) on the basis of two prospective, open-label, uncontrolled trials with a total of 37 treated patients, of which 6 were adolescents,<sup>87</sup> and a retrospective experience with 17 pediatric patients age 2 months to 17 years (unpublished, summarized in the package insert). Most patients in all the studies showed improvement in blood counts and renal function, and freedom from need for plasma therapy. It is not known if ecuzumab will be effective in infection-induced HUS.<sup>88</sup> Treatment is by intravenous administration, initially every week and then every 2 weeks, continued indefinitely. Whether therapy can be stopped successfully in some patients is subject to further investigation,<sup>89</sup> as is the potential use of ecuzumab in children with PNH.<sup>90</sup> In analogy with the congenital terminal component complement deficiencies,<sup>91</sup> ecuzumab therapy is associated with increased susceptibility to infections with Gram-negative organisms, including *Neisseria meningitidis*.<sup>92</sup>

**Etanercept (Enbrel®).** Etanercept is a soluble form of the p75 receptor for TNF. It is a recombinant chimeric homodimer consisting of two polypeptide chains that splice the TNF receptor subunit to the Fc portion of IgG1. It binds both TNF- $\alpha$  and TNF- $\beta$  (also known as lymphotoxin alpha, LT $\alpha$ ) in both the soluble and transmembrane forms. It was first approved for the treatment of adult rheumatoid arthritis in 1998.<sup>93</sup> In 1999, the indication for polyarticular JIA in patients  $\geq 4$  years old was added on the basis of an open-label study of 69 patients, followed by a controlled, double-blind 4-month withdrawal study on the 51 patients who initially responded.<sup>94</sup> In 2007, the age indication was lowered to  $\geq 2$  years on the basis of open-label unpublished experience (mentioned in the package insert). Etanercept is administered by subcutaneous injection 1 to 2 times per week. Safety concerns listed in the package insert include infections, malignancies (particularly lymphomas)<sup>22</sup> and the development of autoimmune disease such as multiple sclerosis or lupus. Etanercept therapy may have a lower risk for activation of tuberculosis, compared to monoclonal antibodies against TNF.<sup>95</sup> In addition, the association of malignancies with etanercept and other anti-TNF agents has been questioned in recent analyses.<sup>96–99</sup> Etanercept also has adult indications for ankylosing spondylitis, psoriasis and psoriatic arthritis.<sup>100–102</sup> It does not have the same effectiveness in inflammatory bowel disease as the monoclonal antibody anti-TNF agents.<sup>103</sup>

**Infliximab (Remicade®).** Infliximab was the first anti-TNF monoclonal antibody to be approved, starting in 1998 with the indication for Crohn's disease in adults.<sup>104–105</sup> Adult rheumatoid arthritis was included in 1999<sup>106</sup> and adult ulcerative colitis in 2005.<sup>107</sup> Treatment of children ( $\geq 6$  years old) with Crohn's disease was added to the label in 2006, based on an open-label trial of an initial 10-week treatment period, followed by randomization of responding patients to maintenance treatment

every 8 weeks or every 12 weeks.<sup>108</sup> Pediatric ulcerative colitis received approval in 2011 based on a very similar open-label study.<sup>109</sup> A phase III trial of 122 children (ages 4–17) with polyarticular JIA failed to meet its primary outcome for statistically significant efficacy at 14 weeks, so this indication does not appear on the label.<sup>110</sup> Nevertheless, the general anecdotal experience has been positive, and infliximab is included among the TNF inhibitors recommended by the American College of Rheumatology for treatment of JIA.<sup>111–113</sup> Childhood autoimmune uveitis is another relatively common off-label usage.<sup>114,115</sup> Safety issues with infliximab include infections, especially tuberculosis. A relatively high incidence of immune responses to infliximab (HACA) has been seen in children, as have serious infusion reactions.<sup>104</sup> Infliximab is administered intravenously at weeks 0, 2 and 6, and then every 8 weeks.

**Omalizumab (Xolair®).** Omalizumab is a recombinant humanized monoclonal antibody that binds the constant region of free IgE.<sup>116</sup> It thus blocks the binding of IgE to cell surface receptors on basophils and mast cells, but it does not cross-link IgE that is already cell bound. It causes a large increase in serum IgE, in the form of omalizumab-IgE complexes. It was approved in 2003 for the treatment of severe to moderate chronic allergic asthma in patients  $\geq 12$  years old who are not controlled with inhaled corticosteroids.<sup>117–119</sup> It is not used in the setting of acute exacerbations. Two other trials evaluated omalizumab in children between 6 and 12 years old. Although the one efficacy trial met its primary endpoint (rate of asthma exacerbations), other efficacy outcomes did not show statistical superiority over placebo. Based on safety concerns (see below), it was decided that it was not appropriate to extend the label indication to children < 12 years old. In 2014, the indication for chronic idiopathic urticaria was added with the same age limitation.<sup>120</sup> Data to support this label change came from two phase III studies with a total of 640 patients treated over 12 or 24 weeks. The major safety issues with omalizumab have been anaphylaxis, serum sickness, parasitic infestations and malignancy. Omalizumab is administered subcutaneously every 2 to 4 weeks.

**Palivizumab (Synagis®).** Palivizumab is a humanized monoclonal antibody specific for the envelope fusion protein (RSV-F) of respiratory syncytial virus.<sup>121</sup> It thus prevents cell entry by the virus and cell-to-cell fusion of RSV-infected cells. Its approval in 1998 was based on demonstration of its efficacy in preventing serious RSV infection in two double-blind, randomized, placebo-controlled trials with 2,789 children  $\leq 2$  years of age who were considered to be at high risk because of congenital heart disease, bronchopulmonary dysplasia or prematurity.<sup>122,123</sup> Palivizumab was given intramuscularly in five monthly injections beginning prior to the RSV season. The incidence of hospitalization with proven RSV infection was decreased about 50% in both studies. Children who were hospitalized for RSV infection despite having received the active drug did not show a milder course of disease. The package insert states that palivizumab is indicated for prophylaxis against serious lower respiratory tract RSV in high-risk children. The major safety concern has been anaphylaxis (rare) and other hypersensitivity reactions. Palivizumab is not indicated for the treatment of RSV infection.<sup>124</sup>

**Raxibacumab.** Raxibacumab is a fully human monoclonal antibody that is directed at the protective antigen (PA) moiety of the anthrax toxin (from *Bacillus anthracis*) and that prevents



the toxin from entering cells. It is indicated for the treatment of inhalation anthrax, in combination with appropriate antibiotics. It is also indicated for anthrax prophylaxis if alternatives are not feasible. It is administered as a single intravenous dose. Its approval in 2012 was based on its low toxicity profile in over 500 normal (adult) volunteers, and therapeutic efficacy in monkey and rabbit models of anthrax.<sup>125–127</sup> For evident ethical and logistical issues, it has never been tested in humans for its approved indication. It is available only from the Centers for Disease Control and Prevention (CDC).

**Rilonacept (Arcalyst®).** Rilonacept is a genetically engineered cytokine ‘trap’ that binds IL-1 $\beta$  with very high affinity.<sup>128–130</sup> With lower affinity, it also binds IL-1 $\alpha$  and IL-1Ra. Rilonacept was approved in 2008 for treatment in patients  $\geq$  12 years old with CAPS. Approval was based on two sequential randomized controlled trials with the same 47 adult patients (44 with FCAS; 3 with MWS): part A consisted of a 6-week placebo-controlled treatment period; this was immediately followed by part B, which began with 9 weeks of patient-blinded active treatment, followed by 9 weeks of placebo-controlled randomized withdrawal.<sup>131</sup> The institution of rilonacept produced a rapid and sustained reduction in patient-reported symptoms (the primary outcome) in the great majority of subjects, while the group withdrawn to placebo experienced a return in symptoms beginning at around 3 weeks. Treatment also normalized serum markers of inflammation, including CRP and serum amyloid protein. Pediatric data were not required with the initial approval, as rilonacept was given an orphan drug designation. Clinical responses were maintained over a subsequent 72-week open-label extension study of 44 subjects from the pivotal trial plus 57 new patients.<sup>132</sup> The additional patients included eight children, age 12 to 17. Two deaths in adult patients were caused by pneumococcal meningitis and coronary artery disease, respectively, but were not considered to be drug related. The most common drug-related adverse event has been injection site reactions. About one quarter of treated patients have been found to develop anti-rilonacept antibodies, usually in low titer.<sup>132</sup> In two patients this was associated with pharmacokinetic changes, but the clinical significance of these findings is not yet apparent. Rilonacept is administered by weekly subcutaneous injections.

**Tocilizumab (Actemra®).** Tocilizumab is a recombinant humanized monoclonal antibody that binds the soluble and membrane-bound forms of the IL-6 receptor and prevents its interaction with IL-6. It was approved for the treatment of adult rheumatoid arthritis in 2010.<sup>133</sup> An indication for systemic JIA was added in 2011, and for polyarticular JIA in 2013. Supporting data for the SJIA label came from a 12-week randomized, placebo-controlled trial of 112 children ages 2 to 17, in which the tocilizumab-treated patients showed substantially more improvement than the placebo group (e.g. ACR70 of 71% vs 8%). Improvement was maintained over a 40-week open-label extension study.<sup>134</sup> Supporting data for the polyarticular JIA

label came from a three-phase study of 188 patients ages 2 to 17. An active 16-week lead-in period resulted in 166 patients achieving an ACR30 and progressing to the 40-week randomized, placebo-controlled withdrawal period with disease flare as a primary outcome measure.<sup>135</sup> Twenty-six percent of tocilizumab-treated patients experienced a flare, compared to 48% of placebo-treated patients. Responses were maintained over a further 48-week open-label extension. Significant adverse events have included neutropenia, elevated cholesterol and liver function tests, and serious infections.<sup>136,137</sup> Macrophage activation syndrome was seen in some of the clinical trials, with an overall incidence of one to two per 100 patient years, which was not felt to represent an increased risk.<sup>138</sup> Tocilizumab is administered to children in the intravenous preparation, every 4 weeks for polyarticular JIA and every 2 weeks for systemic JIA.

## Conclusions

Targeted recombinant biologicals have been developed over the last three decades. They generally take advantage of the exquisite specificity and avidity of binding of the antibody response or physiologic receptor-ligand interactions. We have discussed here 15 compounds that have received FDA approval since 1998 for use in pediatric populations, mostly for inflammatory conditions but also for malignancy, transplant rejection, hypersensitivity and certain infections. More than half of these agents were licensed after 2005 (see Table 17-3). Ongoing trials of new agents in children are currently exploring novel targets such as IL-5,<sup>139</sup> CD22,<sup>140</sup> EGFR (epidermal growth factor receptor),<sup>141</sup> IGF-1R (insulin-like growth factor-1 receptor),<sup>142</sup> IFN- $\gamma$ ,<sup>143</sup> and GD2 (disialoganglioside, expressed on neuroblastoma and some other malignancies).<sup>144</sup> Many more targets are being explored in adult populations, and undoubtedly some successful compounds will find their use extended to younger patients.<sup>145</sup> Biological targeting mechanisms other than recombinant proteins, including those using genetically modified living cells, have shown early promise, such as the use of CAR (chimeric antigen receptor)-modified T cells.<sup>146</sup> Gene therapy approaches with nucleic acid constructs of DNA or RNA have great appeal in principle, but are still far from realizing their potential.<sup>147</sup> Undoubtedly, further genetic and molecular understanding of the complexities of in vivo pathways will uncover additional therapeutic options using the targeting specificity of biologicals. This field can be expected to change rapidly in the coming years.

## Helpful Websites

Immune Deficiency Foundation website ([www.primaryimmune.org](http://www.primaryimmune.org))

The complete reference list can be found on the companion Expert Consult website at <http://www.expertconsult.inkling.com>.

## KEY REFERENCES

- Gompels MM, Lock RJ. Cinryze (C1-inhibitor) for the treatment of hereditary angioedema. *Expert Rev Clin Immunol* 2011;7:569–73.
- Mitchell PL, Morland B, Stevens MC, Dick G, Easlea D, Meyer LC, et al. Granulocyte colony-stimulating factor in established febrile neutropenia: a randomized study of pediatric patients. *J Clin Oncol* 1997;15:1163–70.
- Dale DC, Bonilla MA, Davis MW, Nakanishi AM, Hammond WP, Kurtzberg J, et al. A randomized controlled phase III trial of recombinant human granulocyte colony-stimulating factor (filgrastim) for treatment of severe chronic neutropenia. *Blood* 1993;81:2496–502.

18. Klipa D, Mahmud N, Ahsan N. Antibody immunosuppressive therapy in solid organ transplant: Part II. *MAbs* 2010;2:607–12.
31. Beukelman T, Ringold S, Davis TE, DeWitt EM, Pelajo CF, Weiss PF, et al. Disease-modifying antirheumatic drug use in the treatment of juvenile idiopathic arthritis: a cross-sectional analysis of the CARRA Registry. *J Rheumatol* 2012;39:1867–74.
34. Kavcic M, Fisher B, Seif A, Li Y, Huang YS, Walker D, et al. Leveraging administrative data to monitor rituximab use in 2875 patients at 42 freestanding children's hospitals across the United States. *J Pediatr* 2013;162:1252.
94. Lovell DJ, Giannini EH, Reiff A, Cawkwell GD, Silverman ED, Nocton JJ, et al. Etanercept in children with polyarticular juvenile rheumatoid arthritis. *Pediatric Rheumatology Collaborative Study Group. N Engl J Med* 2000;342:763–9.
111. Ringold S, Weiss P, Beukelman T, Dewitt E, Ilowite N, Kimura Y, et al. 2013 update of the 2011 American College of Rheumatology recommendations for the treatment of juvenile idiopathic arthritis: recommendations for the medical therapy of children with systemic juvenile idiopathic arthritis and tuberculosis screening among children receiving biologic medications. *Arthritis Care Res* 2013;65:1551–63.
127. Migone TS, Subramanian G, Zhong J, Healey L, Corey A, Devalaraja M, et al. Raxibacumab for the treatment of inhalational anthrax. *N Engl J Med* 2009;361:135–44.
128. Economides AN, Carpenter LR, Rudge JS, Wong V, Koehler-Stec EM, Hartnett C, et al. Cytokine traps: multi-component, high-affinity blockers of cytokine action. *Nat Med* 2003;9:47–52.

## REFERENCES

- Lumry W, Manning ME, Hurewitz DS, Davis-Lorton M, Fitts D, Kalfus IN, et al. Nanofiltered C1-esterase inhibitor for the acute management and prevention of hereditary angioedema attacks due to C1-inhibitor deficiency in children. *J Pediatr* 2013;162:1017–22, e1–2.
- Gompels MM, Lock RJ, Cinryze (C1-inhibitor) for the treatment of hereditary angioedema. *Expert Rev Clin Immunol* 2011;7:569–73.
- Martin GR, Ongkingo JR, Turner ME, Skurow ES, Ruley EJ. Recombinant erythropoietin (Epogen) improves cardiac exercise performance in children with end-stage renal disease. *Pediatr Nephrol* 1993;7:276–80.
- Mitchell PL, Morland B, Stevens MC, Dick G, Easlea D, Meyer LC, et al. Granulocyte colony-stimulating factor in established febrile neutropenia: a randomized study of pediatric patients. *J Clin Oncol* 1997;15:1163–70.
- Dale DC, Bonilla MA, Davis MW, Nakanishi AM, Hammond WP, Kurtzberg J, et al. A randomized controlled phase III trial of recombinant human granulocyte colony-stimulating factor (filgrastim) for treatment of severe chronic neutropenia. *Blood* 1993;81:2496–502.
- Sokal EM, Conjeevaram HS, Roberts EA, Alvarez F, Bern EM, Goyens P, et al. Interferon alfa therapy for chronic hepatitis B in children: a multinational randomized controlled trial. *Gastroenterology* 1998;114:988–95.
- Key LL Jr, Rodriguez RM, Willi SM, Wright NM, Hatcher HC, Eyre DR, et al. Long-term treatment of osteopetrosis with recombinant human interferon gamma. *N Engl J Med* 1995;332:1594–9.
- A controlled trial of interferon gamma to prevent infection in chronic granulomatous disease. The International Chronic Granulomatous Disease Cooperative Study Group. *N Engl J Med* 1991;324:509–16.
- Hu J, Doucette K, Hartling L, Tjosvold L, Robinson J. Treatment of hepatitis C in children: a systematic review. *PLoS ONE* 2010;5:e11542.
- Schwarz KB, Mohan P, Narkewicz MR, Molleston JP, Nash SR, Hu S, et al. Safety, efficacy and pharmacokinetics of peginterferon alpha2a (40 kd) in children with chronic hepatitis C. *J Pediatr Gastroenterol Nutr* 2006;43:499–505.
- Schwarz KB, Gonzalez-Peralta RP, Murray KF, Molleston JB, Haber BA, Jonas MM, et al. The combination of ribavirin and peginterferon is superior to peginterferon and placebo for children and adolescents with chronic hepatitis C. *Gastroenterology* 2011;140:450–8 e1.
- Wirth S, Ribes-Koninckx C, Calzado MA, Bortolotti F, Zancan L, Jara P, et al. High sustained virologic response rates in children with chronic hepatitis C receiving peginterferon alfa-2b plus ribavirin. *J Hepatol* 2010;52:501–7.
- Wirth S, Pieper-Boustani H, Lang T, Ballauff A, Kullmer U, Gerner P, et al. Peginterferon alfa-2b plus ribavirin treatment in children and adolescents with chronic hepatitis C. *Hepatology* 2005;41:1013–18.
- Geyer MB, Jacobson JS, Freedman J, George D, Moore V, van de Ven C, et al. A comparison of immune reconstitution and graft-versus-host disease following myeloablative conditioning versus reduced toxicity conditioning and umbilical cord blood transplantation in paediatric recipients. *Br J Haematol* 2011;155:218–34.
- Bennett CL, Luminari S, Nissenson AR, Tallman MS, Klinge SA, McWilliams N, et al. Pure red-cell aplasia and epoetin therapy. *N Engl J Med* 2004;351:1403–8.
- Kozlowski S, Woodcock J, Midthun K, Sherman RB. Developing the Nation's Biosimilars Program. *N Engl J Med* 2011;365:385–8.
- McCarnish M, Woollett G. Worldwide experience with biosimilar development. *MABS* 2011;3:209–17.
- Klipa D, Mahmud N, Ahsan N. Antibody immunosuppressive therapy in solid organ transplant: Part II. *MABS* 2010;2:607–12.
- Mahmud N, Klipa D, Ahsan N. Antibody immunosuppressive therapy in solid-organ transplant: Part I. *MABS* 2010;2:148–56.
- Chamarthy M, Williams S, Moadel R. Radioimmunotherapy of non-Hodgkin's lymphoma: from the 'magic bullets' to 'radioactive magic bullets'. *Yale J Biol Med* 2011;84:391–407.
- Maini RN, Breedveld FC, Kalden JR, Smolen JS, Davis D, Macfarlane JD, et al. Therapeutic efficacy of multiple intravenous infusions of anti-tumor necrosis factor alpha monoclonal antibody combined with low-dose weekly methotrexate in rheumatoid arthritis. *Arthritis Rheum* 1998;41:1552–63.
- Rosenblum H, Amital H. Anti-TNF therapy: safety aspects of taking the risk. *Autoimmun Rev* 2011;10:563–8.
- Keating G. Eculizumab: a review of its use in atypical haemolytic uraemic syndrome. *Drugs* 2013;73:2053–66.
- McCandless RT, Minich LL, Tani LY, Williams RV. Does abciximab promote coronary artery remodeling in patients with Kawasaki disease? *Am J Cardiol* 2010;105:1625–8.
- Williams RV, Wilke VM, Tani LY, Minich LL. Does abciximab enhance regression of coronary aneurysms resulting from Kawasaki disease? *Pediatrics* 2002;109:E4.
- Marsh R, Allen C, McClain K, Weinstein J, Kanter J, Skiles J, et al. Salvage therapy of refractory hemophagocytic lymphohistiocytosis with alemtuzumab. *Pediatr Blood Cancer* 2013;60:101–9.
- Machaczka M, Vaktas J, Chiang SC, Bryceson YT. Alemtuzumab treatment for hemophagocytic lymphohistiocytosis. *Nat Rev Clin Oncol* 2010;7.
- Hui-Yuen J, Bermudez-Santiago L, Isgro J, Eichenfield A, Starr A, Imundo L, et al. A23: favorable response to belimumab in childhood-onset systemic lupus erythematosus. *Arthritis Rheumatol* 2014;66(Suppl 11):S37.
- Gururangan S, Fangusaro J, Poussaint TY, McLendon RE, Onar-Thomas A, Wu S, et al. Efficacy of bevacizumab plus irinotecan in children with recurrent low-grade gliomas – a Pediatric Brain Tumor Consortium study. *Neuro-Oncol* 2013;16:310–17.
- Tahija SG, Hersetyati R, Lam GC, Kusaka S, McMenamin PG. Fluorescein angiographic observations of peripheral retinal vessel growth in infants after intravitreal injection of bevacizumab as sole therapy for zone I and posterior zone II retinopathy of prematurity. *Br J Ophthalmol* 2014;98:507–12.
- Beukelman T, Ringold S, Davis TE, DeWitt EM, Pelajo CF, Weiss PE, et al. Disease-modifying antirheumatic drug use in the treatment of juvenile idiopathic arthritis: a cross-sectional analysis of the CARRA Registry. *J Rheumatol* 2012;39:1867–74.
- Miserocchi E, Modorati G, Pontikaki I, Meroni PL, Gerloni V. Long-term treatment with golimumab for severe uveitis. *Ocul Immunol Inflamm* 2014;22:90–5.
- Kornek B, Aboul-Enein F, Rostasy K, Milos R-II, Steiner I, Penzien J, et al. Natalizumab therapy for highly active pediatric multiple sclerosis. *JAMA Neurol* 2013;70:469–75.
- Kavcic M, Fisher B, Seif A, Li Y, Huang YS, Walker D, et al. Leveraging administrative data to monitor rituximab use in 2875 patients at 42 freestanding children's hospitals across the United States. *J Pediatr* 2013;162:1252.
- Worch J, Rohde M, Burkhardt B. Mature B cell lymphoma and leukemia in children and adolescents – review of standard chemotherapy regimen and perspectives. *Pediatr Hematol Oncol* 2013;30:465–83.
- Luu M, Cordero KM. The evolving role of biologics in the treatment of pediatric psoriasis. *Skin Therapy Lett* 2013;18:1–4.
- Goldzweig O, Hashkes PJ. Abatacept in the treatment of polyarticular JIA: development, clinical utility, and place in therapy. *Drug Des Devel Ther* 2011;5:61–70.
- Egen JG, Kuhns MS, Allison JP. CTLA-4: new insights into its biological function and use in tumor immunotherapy. *Nat Immunol* 2002;3:611–18.
- Ruperto N, Lovell DJ, Quartier P, Paz E, Rubio-Perez N, Silva CA, et al. Abatacept in children with juvenile idiopathic arthritis: a randomised, double-blind, placebo-controlled withdrawal trial. *Lancet* 2008;372:383–91.
- Ruperto N, Lovell D, Quartier P, Paz E, Rubio-Perez N, Silva C, et al. Long-term safety and efficacy of abatacept in children with juvenile idiopathic arthritis. *Arthritis Rheum* 2010;62:1792–802.
- Salliot C, Dougados M, Gossec L. Risk of serious infections during rituximab, abatacept and anakinra treatments for rheumatoid arthritis: meta-analyses of randomised placebo-controlled trials. *Ann Rheum Dis* 2009;68:25–32.
- Johnston SS, Turpcu A, Shi N, Fowler R, Chu B-C, Alexander K. Risk of infections in rheumatoid arthritis patients switching from anti-TNF agents to rituximab, abatacept, or another anti-TNF agent, a retrospective administrative claims analysis. *Semin Arthritis Rheum* 2013;43:39–47.
- Singh J, Wells G, Christensen R, Tanjong Ghogomu E, Maxwell L, Macdonald J, et al. Adverse effects of biologics: a network meta-analysis and Cochrane overview. *Cochrane Database Syst Rev* 2011;2:CD008794.
- Kim PS, Ho GY, Prete PE, Furst DE. Safety and efficacy of abatacept in eight rheumatoid arthritis patients with chronic hepatitis B. *Arthritis Care Res (Hoboken)* 2012;64:1265–8.
- Keating G. Abatacept: a review of its use in the management of rheumatoid arthritis. *Drugs* 2013;73:1095–119.
- Weinblatt M, Keystone E, Furst D, Moreland L, Weisman M, Birbara C, et al. Adalimumab, a fully human anti-tumor necrosis factor alpha monoclonal antibody, for the treatment of rheumatoid arthritis in patients taking

- concomitant methotrexate: the ARMADA trial. *Arthritis Rheum* 2003;48:35–45.
47. Lovell DJ, Ruperto N, Goodman S, Reiff A, Jung L, Jarosova K, et al. Adalimumab with or without methotrexate in juvenile rheumatoid arthritis. *N Engl J Med* 2008;359:810–20.
  48. Diak P, Siegel J, La Grenade L, Choi L, Lemery S, McMahon A. Tumor necrosis factor alpha blockers and malignancy in children: forty-eight cases reported to the Food and Drug Administration. *Arthritis Rheum* 2010;62:2517–24.
  49. Keystone E. Does anti-tumor necrosis factor- $\alpha$  therapy affect risk of serious infection and cancer in patients with rheumatoid arthritis?: a review of longterm data. *J Rheumatol* 2011;38:1552–62.
  50. Korschwagen L, Bartelds G, Kriekaert C, Turkstra F, Nurmohamed M, van Schaardenburg D, et al. Venous and arterial thromboembolic events in adalimumab-treated patients with antiadalimumab antibodies: a case series and cohort study. *Arthritis Rheum* 2011;63:877–83.
  51. Kriekaert C, Jamnitski A, Nurmohamed M, Kostense P, Boers M, Wolbink G. Comparison of long-term clinical outcome with etanercept treatment and adalimumab treatment of rheumatoid arthritis with respect to immunogenicity. *Arthritis Rheum* 2012;64:3850–5.
  52. Arend W, Gabay C. Physiologic role of interleukin-1 receptor antagonist. *Arthritis Res* 2000;2:245–8.
  53. Fleischmann R, Schechtman J, Bennett R, Handel M, Burmester GR, Tesser J, et al. Anakinra, a recombinant human interleukin-1 receptor antagonist (r-metHuIL-1ra), in patients with rheumatoid arthritis: A large, international, multicenter, placebo-controlled trial. *Arthritis Rheum* 2003;48:927–34.
  54. Goldbach-Mansky R, Dailey NJ, Canna SW, Gelabert A, Jones J, Rubin BI, et al. Neonatal-onset multisystem inflammatory disease responsive to interleukin-1beta inhibition. *N Engl J Med* 2006;355:581–92.
  55. Sibley C, Plass N, Snow J, Wiggs E, Brewer C, King K, et al. Sustained response and prevention of damage progression in patients with neonatal-onset multisystem inflammatory disease treated with anakinra: a cohort study to determine three- and five-year outcomes. *Arthritis Rheum* 2012;64:2375–86.
  56. Leinonen M, Hallén B, Olivecrona H. A2: rapid and sustained response in patients suffering from severe cryopyrin-associated periodic syndromes treated with anakinra (Kineret®). *Arthritis Rheumatol* 2014;66(Suppl 11):S3.
  57. Lequerré T, Quartier P, Rosellini D, Alaoui F, De Bandt M, Mejjad O, et al. Interleukin-1 receptor antagonist (anakinra) treatment in patients with systemic-onset juvenile idiopathic arthritis or adult onset Still disease: preliminary experience in France. *Ann Rheum Dis* 2008;67:302–8.
  58. Pascual V, Allantaz F, Arce E, Punaro M, Banchereau J. Role of interleukin-1 (IL-1) in the pathogenesis of systemic onset juvenile idiopathic arthritis and clinical response to IL-1 blockade. *J Exp Med* 2005;201:1479–86.
  59. McKeage K, McCormack P. Basiliximab: a review of its use as induction therapy in renal transplantation. *Biodrugs* 2010;24:55–76.
  60. Kahan BD, Rajagopalan PR, Hall M. Reduction of the occurrence of acute cellular rejection among renal allograft recipients treated with basiliximab, a chimeric anti-interleukin-2-receptor monoclonal antibody. United States Simulect Renal Study Group. *Transplantation* 1999;67:276–84.
  61. Nashan B, Moore R, Amlot P, Schmidt A, Abeywickrama K, Souillou J. Randomised trial of basiliximab versus placebo for control of acute cellular rejection in renal allograft recipients. CHIB 201 International Study Group. *Lancet* 1997;350:1193–8.
  62. Kovarik JM, Offner G, Broyer M, Niaudet P, Loirat C, Mentser M, et al. A rational dosing algorithm for basiliximab (Simulect) in pediatric renal transplantation based on pharmacokinetic-dynamic evaluations. *Transplantation* 2002;74:966–71.
  63. Offner G, Broyer M, Niaudet P, Loirat C, Mentser M, Lemire J, et al. A multicenter, open-label, pharmacokinetic/pharmacodynamic safety, and tolerability study of basiliximab (Simulect) in pediatric de novo renal transplant recipients. *Transplantation* 2002;74:961–6.
  64. Brennan D, Daller J, Lake K, Cibrik D, Del Castillo D. Thymoglobulin Induction Study G. Rabbit antithymocyte globulin versus basiliximab in renal transplantation. *N Engl J Med* 2006;355:1967–77.
  65. Barros V, Rocha V, Garcia V, Garcia C. Anaphylactic shock after retreatment with basiliximab. *Transplant Proc* 2003;35:579.
  66. Baudouin V, Crusiaux A, Haddad E, Schandene L, Goldman M, Loirat C, et al. Anaphylactic shock caused by immunoglobulin E sensitization after retreatment with the chimeric anti-interleukin-2 receptor monoclonal antibody basiliximab. *Transplantation* 2003;76:459–63.
  67. Lachmann H, Kone-Paut I, Kuemmerle-Deschner J, Leslie K, Hachulla E, Quartier P, et al. Use of canakinumab in the cryopyrin-associated periodic syndrome. *N Engl J Med* 2009;360:2416–25.
  68. Ruperto N, Brunner H, Quartier P, Constantin T, Wulffraat N, Horneff G, et al. Two randomized trials of canakinumab in systemic juvenile idiopathic arthritis. *N Engl J Med* 2012;367:2396–406.
  69. Lacey D, Timms E, Tan H, Kelley M, Dunstan C, Burgess T, et al. Osteoprotegerin ligand is a cytokine that regulates osteoclast differentiation and activation. *Cell* 1998;93:165–76.
  70. Lewiecki E, Bilezikian J. Denosumab for the treatment of osteoporosis and cancer-related conditions. *Clin Pharmacol Ther* 2012;91:123–33.
  71. Brown JE, Coleman RE. Denosumab in patients with cancer – a surgical strike against the osteoclast. *Nat Rev Clin Oncol* 2012;9:110–18.
  72. Xu S, Adams B, Yu X, Xu M. Denosumab and giant cell tumour of bone—a review and future management considerations. *Curr Oncol* 2013;20:e422–7.
  73. Thomas D, Henshaw R, Skubitiz K, Chawla S, Staddon A, Blay JY, et al. Denosumab in patients with giant-cell tumour of bone: an open-label, phase 2 study. *Lancet Oncol* 2010;11:275–80.
  74. Balke M. Denosumab treatment of giant cell tumour of bone. *Lancet Oncol* 2013;14:801–2.
  75. Chawla S, Henshaw R, Seeger L, Choy E, Blay JY, Ferrari S, et al. Safety and efficacy of denosumab for adults and skeletally mature adolescents with giant cell tumour of bone: interim analysis of an open-label, parallel-group, phase 2 study. *Lancet Oncol* 2013;14:901–8.
  76. Bernstein JA, Qazi M. Ecallantide: its pharmacology, pharmacokinetics, clinical efficacy and tolerability. *Expert Rev Clin Immunol* 2010;6:29–39.
  77. Markland W, Ley AC, Ladner RC. Iterative optimization of high-affinity protease inhibitors using phage display. 2. Plasma kallikrein and thrombin. *Biochemistry* 1996;35:8058–67.
  78. Sheffer A, Campion M, Levy R, Li H, Horn P, Pullman W. Ecallantide (DX-88) for acute hereditary angioedema attacks: integrated analysis of 2 double-blind, phase 3 studies. *J Allergy Clin Immunol* 2011;128:153–9.
  79. Cicardi M, Levy R, McNeil D, Li H, Sheffer A, Campion M, et al. Ecallantide for the treatment of acute attacks in hereditary angioedema. *N Engl J Med* 2010;363:523–31.
  80. Levy JH, Freiberger DJ, Roback J. Hereditary angioedema: current and emerging treatment options. *Anesth Analg* 2010;110:1271–80.
  81. Macginnitie AJ, Campion M, Stolz LE, Pullman WE. Ecallantide for treatment of acute hereditary angioedema attacks: Analysis of efficacy by patient characteristics. *Allergy Asthma Proc* 2012;33:178–85.
  82. Macginnitie A. Pediatric hereditary angioedema. *Pediatr Allergy Immunol* 2014;25:420–7.
  83. Sheffer A, MacGinnitie A, Campion M, Stolz L, Pullman W. Outcomes after ecallantide treatment of laryngeal hereditary angioedema attacks. *Ann Allergy Asthma Immunol* 2013;110:184–8.
  84. Farkas H, Varga L. Ecallantide is a novel treatment for attacks of hereditary angioedema due to C1 inhibitor deficiency. *Clin Cosmet Investig Dermatol* 2011;4:61–8.
  85. Schmidtko J, Peine S, El-Housseini Y, Pascual M, Meier P. Treatment of atypical hemolytic uremic syndrome and thrombotic microangiopathies: a focus on eculizumab. *Am J Kidney Dis* 2013;61:289–99.
  86. Hillmen P, Young NS, Schubert J, Brodsky RA, Socie G, Muus P, et al. The complement inhibitor eculizumab in paroxysmal nocturnal hemoglobinuria. *N Engl J Med* 2006;355:1233–43.
  87. Legendre CM, Licht C, Muus P, Greenbaum LA, Babu S, Bedrosian C, et al. Terminal complement inhibitor eculizumab in atypical hemolytic-uremic syndrome. *NEJM* 2013;368:2169–81.
  88. Lapeyraque AL, Malina M, Fremeaux-Bacchi V, Boppel T, Kirschfink M, Oualha M, et al. Eculizumab in severe Shiga-toxin-associated HUS. *N Engl J Med* 2011;364:2561–3.
  89. Ardissino G, Testa S, Possenti I, Tel F, Paglialonga F, Salardi S, et al. Discontinuation of eculizumab maintenance treatment for atypical hemolytic uremic syndrome: A report of 10 cases. *Am J Kidney Dis* 2014;64:633–7.
  90. Reiss U, Schwartz J, Sakamoto K, Puthenveetil G, Ogawa M, Bedrosian C, et al. Efficacy and safety of eculizumab in children and adolescents with paroxysmal nocturnal hemoglobinuria. *Pediatr Blood Cancer* 2014;61:1544–50.
  91. Ram S, Lewis L, Rice P. Infections of people with complement deficiencies and patients who have undergone splenectomy. *Clin Microbiol Rev* 2010;23:740–80.
  92. Bouts A, Monnens L, Davin J-C, Struijk G, Spanjaard L. Insufficient protection by



- Neisseria meningitidis* vaccination alone during eculizumab therapy. *Pediatr Nephrol* 2011;26:1919–20.
93. Moreland LW, Schiff MH, Baumgartner SW, Tindall EA, Fleischmann RM, Bulpitt KJ, et al. Etanercept therapy in rheumatoid arthritis. A randomized, controlled trial. *Ann Intern Med* 1999;130:478–86.
  94. Lovell DJ, Giannini EH, Reiff A, Cawkwell GD, Silverman ED, Nocton JJ, et al. Etanercept in children with polyarticular juvenile rheumatoid arthritis. Pediatric Rheumatology Collaborative Study Group. *N Engl J Med* 2000;342:763–9.
  95. Tubach F, Salmon D, Ravaud P, Allanore Y, Goupille P, Bréban M, et al. Risk of tuberculosis is higher with anti-tumor necrosis factor monoclonal antibody therapy than with soluble tumor necrosis factor receptor therapy: The three-year prospective French Research Axed on Tolerance of Biotherapies registry. *Arthritis Rheum* 2009;60:1884–94.
  96. Haynes K, Beukelman T, Curtis J, Newcomb C, Herrinton L, Graham D, et al. Tumor necrosis factor  $\alpha$  inhibitor therapy and cancer risk in chronic immune-mediated diseases. *Arthritis Rheum* 2013;65:48–58.
  97. Askling J, van Vollenhoven R, Granath F, Raaschou P, Fored C, Baecklund E, et al. Cancer risk in patients with rheumatoid arthritis treated with anti-tumor necrosis factor alpha therapies: does the risk change with the time since start of treatment? *Arthritis Rheum* 2009;60:3180–9.
  98. Raaschou P, Simard J, Neovius M, Askling J, Anti-Rheumatic Therapy in Sweden Study Group. Does cancer that occurs during or after anti-tumor necrosis factor therapy have a worse prognosis? A national assessment of overall and site-specific cancer survival in rheumatoid arthritis patients treated with biologic agents. *Arthritis Rheum* 2011;63:1812–22.
  99. Le Blay P, Mouterde G, Barnetche T, Morel J, Combe B. Risk of malignancy including non-melanoma skin cancers with anti-tumor necrosis factor therapy in patients with rheumatoid arthritis: meta-analysis of registries and systematic review of long-term extension studies. *Clin Exp Rheumatol* 2012;30:756–64.
  100. Mease P, Goffe B, Metz J, VanderStoep A, Finck B, Burge D. Etanercept in the treatment of psoriatic arthritis and psoriasis: a randomised trial. *Lancet* 2000;356:385–90.
  101. Leonardi CL, Powers JL, Matheson RT, Goffe BS, Zitnik R, Wang A, et al. Etanercept as monotherapy in patients with psoriasis. *N Engl J Med* 2003;349:2014–22.
  102. Gorman JD, Sack KE, Davis JC Jr. Treatment of ankylosing spondylitis by inhibition of tumor necrosis factor alpha. *N Engl J Med* 2002;346:1349–56.
  103. Sandborn W, Hanauer S, Katz S, Safdi M, Wolf D, Baerg R, et al. Etanercept for active Crohn's disease: a randomized, double-blind, placebo-controlled trial. *Gastroenterology* 2001;121:1088–94.
  104. Hanauer S, Feagan B, Lichtenstein G, Mayer L, Schreiber S, Colombel J, et al. Maintenance infliximab for Crohn's disease: the ACCENT I randomised trial. *Lancet* 2002;359:1541–9.
  105. Targan SR, Hanauer SB, van Deventer SJ, Mayer L, Present DH, Braakman T, et al. A short-term study of chimeric monoclonal antibody cA2 to tumor necrosis factor alpha for Crohn's disease. Crohn's Disease cA2 Study Group. *N Engl J Med* 1997;337:1029–35.
  106. Lipsky PE, van der Heijde DM, St Clair EW, Furst DE, Breedveld FC, Kalden JR, et al. Infliximab and methotrexate in the treatment of rheumatoid arthritis. Anti-Tumor Necrosis Factor Trial in Rheumatoid Arthritis with Concomitant Therapy Study Group. *N Engl J Med* 2000;343:1594–602.
  107. Rutgeerts P, Sandborn W, Feagan B, Reinisch W, Olson A, Johanns J, et al. Infliximab for induction and maintenance therapy for ulcerative colitis. *N Engl J Med* 2005;353(23):2462–76.
  108. Hyams J, Crandall W, Kugathasan S, Griffiths A, Olson A, Johanns J, et al. Induction and maintenance infliximab therapy for the treatment of moderate-to-severe Crohn's disease in children. *Gastroenterology* 2007;132:863.
  109. Hyams J, Damaraju L, Blank M, Johanns J, Guzzo C, Winter HS, et al. Induction and maintenance therapy with infliximab for children with moderate to severe ulcerative colitis. *Clin Gastroenterol Hepatol* 2012;10(4):391–9 e1.
  110. Ruperto N, Lovell D, Cuttica R, Wilkinson N, Woo P, Espada G, et al. A randomized, placebo-controlled trial of infliximab plus methotrexate for the treatment of polyarticular-course juvenile rheumatoid arthritis. *Arthritis Rheum* 2007;56:3096–106.
  111. Ringold S, Weiss P, Beukelman T, Dewitt E, Ilowite N, Kimura Y, et al. 2013 update of the 2011 American College of Rheumatology recommendations for the treatment of juvenile idiopathic arthritis: recommendations for the medical therapy of children with systemic juvenile idiopathic arthritis and tuberculosis screening among children receiving biologic medications. *Arthritis Care Res* 2013;65:1551–63.
  112. Beukelman T, Patkar N, Saag K, Tolleson-Rinehart S, Cron R, DeWitt E, et al. American College of Rheumatology recommendations for the treatment of juvenile idiopathic arthritis: initiation and safety monitoring of therapeutic agents for the treatment of arthritis and systemic features. *Arthritis Care Res* 2011;63:465–82.
  113. Tambralli A, Beukelman T, Weiser P, Atkinson T, Cron R, Stoll M. High doses of infliximab in the management of juvenile idiopathic arthritis. *J Rheumatol* 2013;40:1749–55.
  114. Kruh J, Yang P, Suelves A, Foster C. Infliximab for the treatment of refractory noninfectious uveitis: a study of 88 patients with long-term follow-up. *Ophthalmology* 2014;121:358–64.
  115. Simonini G, Katie D, Cimaz R, Macfarlane G, Jones G. Current evidence of anti-TNF $\alpha$  treatment efficacy in childhood chronic uveitis: A systematic review and meta-analysis approach of individual drugs. *Arthritis Care Res* 2013;66:1073–84.
  116. Vichyanond P. Omalizumab in allergic diseases, a recent review. *Asian Pac J Allergy Immunol* 2011;29:209–19.
  117. Bousquet J, Cabrera P, Berkman N, Buhl R, Holgate S, Wenzel S, et al. The effect of treatment with omalizumab, an anti-IgE antibody, on asthma exacerbations and emergency medical visits in patients with severe persistent asthma. *Allergy* 2005;60:302–8.
  118. Humbert M, Beasley R, Ayres J, Slavin R, Hébert J, Bousquet J, et al. Benefits of omalizumab as add-on therapy in patients with severe persistent asthma who are inadequately controlled despite best available therapy (GINA 2002 step 4 treatment): INNOVATE. *Allergy* 2005;60:309–16.
  119. Soler M, Matz J, Townley R, Buhl R, O'Brien J, Fox H, et al. The anti-IgE antibody omalizumab reduces exacerbations and steroid requirement in allergic asthmatics. *Eur Respir J* 2001;18:254–61.
  120. Maurer M, Rosen K, Hsieh HJ, Saini S, Grattan C, Gimenez-Arnau A, et al. Omalizumab for the treatment of chronic idiopathic or spontaneous urticaria. *N Engl J Med* 2013;368:924–35.
  121. Sun Z, Pan Y, Jiang S, Lu L. Respiratory syncytial virus entry inhibitors targeting the F protein. *Viruses*. 2013;5:211–25.
  122. The IMpact-RSV Study Group. Palivizumab, a humanized respiratory syncytial virus monoclonal antibody, reduces hospitalization from respiratory syncytial virus infection in high-risk infants. *Pediatrics* 1998;102:531–7.
  123. Feltes T, Cabalka A, Meissner H, Piazza F, Carlin D, Top F, et al. Palivizumab prophylaxis reduces hospitalization due to respiratory syncytial virus in young children with hemodynamically significant congenital heart disease. *J Pediatr* 2003;143:532–40.
  124. Hu J, Robinson J. Treatment of respiratory syncytial virus with palivizumab: a systematic review. *World J Pediatr*. 2010;6:296–300.
  125. Corey A, Migone TS, Bolmer S, Fiscella M, Ward C, Chen C, et al. Bacillus anthracis protective antigen kinetics in inhalation spore-challenged untreated or levofloxacin/raxibacumab-treated New Zealand white rabbits. *Toxins* 2013;5:120–38.
  126. Mazumdar S. Raxibacumab. *MAbs* 2009;1:531–8.
  127. Migone TS, Subramanian G, Zhong J, Healey L, Corey A, Devalaraja M, et al. Raxibacumab for the treatment of inhalational anthrax. *N Engl J Med* 2009;361:135–44.
  128. Economides AN, Carpenter LR, Rudge JS, Wong V, Koehler-Stec EM, Hartnett C, et al. Cytokine traps: multi-component, high-affinity blockers of cytokine action. *Nat Med* 2003;9:47–52.
  129. Stahl N, Radin A, Mellis S. Rilonacept – CAPS and beyond. *Ann N Y Acad Sci* 2009;1182:124–34.
  130. Gillespie J, Mathews R, McDermott M. Rilonacept in the management of cryopyrin-associated periodic syndromes (CAPS). *J Inflamm Res* 2010;3:1–8.
  131. Hoffman HM, Throne ML, Amar NJ, Sebai M, Kivitz AJ, Kavanaugh A, et al. Efficacy and safety of rilonacept (interleukin-1 Trap) in patients with cryopyrin-associated periodic syndromes: results from two sequential placebo-controlled studies. *Arthritis Rheum* 2008;58:2443–52.
  132. Hoffman H, Throne M, Amar N, Cartwright R, Kivitz A, Soo Y, et al. Long-term efficacy and safety profile of rilonacept in the treatment of cryopyrin-associated periodic syndromes: results of a 72-week open-label extension study. *Clin Ther* 2012;34:2091–103.
  133. Genovese MC, McKay JD, Nasonov EL, Mysler EF, da Silva NA, Alecock E, et al. Interleukin-6 receptor inhibition with tocilizumab reduces disease activity in rheumatoid arthritis with inadequate response to disease-modifying antirheumatic drugs: the tocilizumab in combination with traditional disease-modifying antirheumatic drug therapy study. *Arthritis Rheum* 2008;58:2968–80.

134. De Benedetti F, Brunner H, Ruperto N, Kenwright A, Wright S, Calvo I, et al. Randomized trial of tocilizumab in systemic juvenile idiopathic arthritis. *N Engl J Med* 2012;367:2385–95.
135. Brunner H, Ruperto N, Zuber Z, Cuttica R, Xavier R, Calvo I, et al. A4: Efficacy and safety of tocilizumab in patients with polyarticular-course juvenile idiopathic arthritis: 2-year data from CHERISH. *Arthritis Rheumatol* 2014;66(Suppl 11):S5–S6.
136. Gurion R, Singer N. Tocilizumab in pediatric rheumatology: the clinical experience. *Curr Rheumatol Rep* 2013;15:338.
137. Decelle K, Horton E. Tocilizumab for the treatment of juvenile idiopathic arthritis. *Ann Pharmacother* 2012;46:822–9.
138. Ravelli A, Schneider R, Weitzman S, Devlin C, Daimaru K, Yokota S, et al. A56: macrophage activation syndrome in patients with systemic juvenile idiopathic arthritis treated with tocilizumab. *Arthritis Rheumatol* 2014;66 (Suppl 11:4):S83–S84.
139. Walsh GM. Profile of reslizumab in eosinophilic disease and its potential in the treatment of poorly controlled eosinophilic asthma. *Biologics* 2012;7:7–11.
140. Kreitman RJ, Tallman MS, Robak T, Coutre S, Wilson WH, Stetler-Stevenson M, et al. Phase I trial of anti-CD22 recombinant immunotoxin moxetumomab pasudotox (CAT-8015 or HA22) in patients with hairy cell leukemia. *J Clin Oncol*. 2012;30:1822–8.
141. Bartels U, Wolff J, Gore L, Dunkel I, Gilheeny S, Allen J, et al. Phase 2 study of safety and efficacy of nimotuzumab in pediatric patients with progressive diffuse intrinsic pontine glioma. *Neuro-Oncol* 2014;16:1554–9.
142. Weigel B, Malempati S, Reid JM, Voss SD, Cho SY, Chen HX, et al. Phase 2 trial of cixutumumab in children, adolescents, and young adults with refractory solid tumors: a report from the Children's Oncology Group. *Pediatr Blood Cancer* 2014;61:452–6.
143. Xu XJ, Tang YM, Song H, Yang SL, Xu WQ, Zhao N, et al. Diagnostic accuracy of a specific cytokine pattern in hemophagocytic lymphohistiocytosis in children. *J Pediatr* 2012;160:984–90 e1.
144. Cheung N-KVK, Cheung IY, Kramer K, Modak S, Kuk D, Pandit-Taskar N, et al. Key role for myeloid cells: phase II results of anti-G(D2) antibody 3F8 plus granulocyte-macrophage colony-stimulating factor for chemoresistant osteomedullary neuroblastoma. *Int J Cancer* 2014;135:2199–205.
145. Reichert JM. Which are the antibodies to watch in 2013? *MABs* 2012;5:1–4.
146. Barrett DM, Singh N, Porter DL, Grupp SA, June CH. Chimeric antigen receptor therapy for cancer. *Annu Rev Med* 2014;65:333–47.
147. Shu SA, Wang J, Tao MH, Leung PS. Gene therapy for autoimmune disease. *Clin Rev Immunol* 2014. DOI:10.1007/s12016-014-8451-x.

# Laboratory Diagnosis of Human Allergic Disease

ROBERT G. HAMILTON

## KEY POINTS

- Allergen-specific IgE antibody is a marker of allergic sensitization and a risk factor for allergic disease but, alone, it does not make the definitive diagnosis of allergic disease. Confirmation of allergic sensitization with a positive IgE anti-allergen analysis increases the likelihood that the patient's symptoms may be a result of an immediate-type hypersensitivity response.
- Quantitative IgE antibody levels to selected foods (milk, egg, fish and peanut) if above a predefined IgE antibody threshold may eliminate the need for tedious and expensive food challenges (DBPCFC). Caution, however, needs to be exercised as the predictive threshold levels vary among clinical studies, due to differences in study populations, protocols and statistical analyses employed.
- Food antigen-specific IgG and IgG4 antibody levels are not diagnostically useful as they do not correlate with the results of oral food challenges.
- Clinically successful aeroallergen immunotherapy is almost always accompanied by high (micrograms/mL) levels of allergen-specific IgG antibody in serum.
- Mast cell tryptase is a serine esterase that is used as a marker of mast cell activation during anaphylaxis. Immunoreactive tryptase levels in serum of healthy adults are typically <5 µg/L. Elevated mature tryptase levels (>10 µg/L) are detectable 1 to 4 hours after the onset of systemic anaphylaxis with hypotension.

The diagnosis of human allergic disease begins and ends with the patient's clinical history and physical examination.<sup>1</sup> When the clinical history identifies allergic symptoms that are in temporal relationship to a definable and relevant allergen exposure, immunoglobulin E (IgE) antibody sensitization is then confirmed with in vivo skin tests (puncture/intradermal, see Chapter 19) or in vitro blood tests (allergen-specific IgE antibody serological assays). If there is a mismatch between the history and these primary diagnostic tests for sensitization, then a secondary provocation test (open or placebo-controlled food challenge, nasal challenge, bronchial challenge) may adjudicate the veracity of the history-driven diagnosis.<sup>2</sup> This chapter discusses the laboratory's contribution to the diagnostic algorithm and analytes that serve as *diagnostic confirmatory tests* when there is high suspicion of allergic disease based on a clinical history.

## Immediate (Type 1) Hypersensitivity Response

Prausnitz and Kustner first described the immediate-type hypersensitivity allergic reaction using an in vivo test in which serum from Kustner, who was allergic to fish, was injected into the skin of Prausnitz.<sup>3</sup> An immediate wheal and flare reaction in the skin was then induced when extracted fish antigen was injected into the same skin site. A serum factor or atopic reagin was later shown to be a novel immunoglobulin (IgE).<sup>4,5</sup>

Box 18-1 summarizes the immune system components that are involved in the induction of IgE antibody and elicitation of the effector mechanisms of type 1 hypersensitivity. Inhalation, skin or parenteral exposure to *allergens* is the initiating event, during which these foreign molecules are presented to antigen-presenting cells on mucosal surfaces. Antigen-presenting cells process antigenic epitopes to *T helper cells* that secrete *cytokines* (IL-4, IL-10, IL-13) which induce *B cell* lymphocyte proliferation. As allergen-specific IgE antibody is produced, it circulates and binds onto FcεR1 receptors on *mast cells* and *basophils*. Upon re-exposure, allergen cross-links receptor bound IgE, causing an influx in calcium, which triggers preformed *mediator release* (*histamine*, *proteases*) and newly synthesized mediators (*leukotrienes*, *prostaglandins*). The pharmacological effects of these mediators on blood vessels and airways produce a spectrum of clinical symptoms including hay fever, asthma, eczema and anaphylaxis. Released *cytokines* (IL-4, IL-5, IL-6) from degranulating mast cells serve to enhance the inflammatory response and IgE production.

An investigation that employed engineered antibodies and allergens showed that the concentration, specific activity (specific IgE to total IgE ratio), affinity (tightness of binding) and clonality (epitope specificity) of the IgE antibody response independently impact on effector cell activation.<sup>6</sup> The study concluded that higher levels of basophil activation occur with higher overall total serum IgE levels, higher Derp2-specific IgE to total IgE ratios, broader clonality and higher IgE antibody affinities. Future serological assays for IgE antibody need to monitor more effectively these four important humoral immune response parameters.<sup>7</sup>

## Allergens

Allergens are substances, usually glycoproteins, that are released from weeds, grasses, trees, animal danders, molds, house dust mites, parasites, insect venoms, occupational substances, drugs and foods. They are capable of inducing IgE antibody (sensitization) in atopic or genetically predisposed individuals. Each of

### BOX 18-1 PRINCIPAL IMMUNE SYSTEM COMPONENTS INVOLVED IN THE INDUCTION OF IgE ANTIBODY AND EFFECTOR MECHANISMS OF TYPE I HYPERSENSITIVITY\*

#### ANTIGEN PRESENTATION

*Allergen* (exposure, entry at mucosal surfaces or local lymph nodes)

Antigen presenting cells (processing and presentation)

T<sub>H</sub>2 lymphocytes

Cytokines (promoters of IgE production: IL4, IL-10, IL-13; inhibitors of IgE production: IF $\gamma$ )

B cell lymphocytes

#### IgE PRODUCTION AND SENSITIZATION

*IgE* (*allergen-specific IgE antibody*)

Connective tissue fixed and mucosal mast cells with Fc $\epsilon$ RI receptors

Circulating basophils with Fc $\epsilon$ RI receptors

#### MAST CELL ACTIVATION AND MEDIATOR RELEASE

Re-exposure to *allergen* induces calcium ion influx into mast cells

Mast cell releases preformed and newly synthesized mediators

Release of *trypase*

Exocytosis of preformed *histamine*

Synthesis of newly formed lipid mediators from arachidonic acid

Prostaglandin D<sub>2</sub>

Leukotriene B<sub>4</sub>, C<sub>4</sub>, D<sub>4</sub>

#### HUMORAL IMMUNE RESPONSE

Chronic antigenic challenge (inadvertent or intentional [immunotherapy]) induces antigen-specific IgG and IgA antibodies in blood and secretions

\*Analytes in italics are routinely measured in the clinical diagnostic allergy laboratory and thus they are discussed in the text. Analytes that are underlined are considered research analytes and they are not routinely measured in the clinical immunology laboratory.

these source materials may be extracted with a physiological buffer to produce a final product (extract) that contains a complex mixture of allergenic and nonallergenic material. With the advent of molecular cloning techniques in the late twentieth century, many clinically important allergenic components have been identified and purified out of these complex allergen extracts. A systematic allergen nomenclature for allergenic extracts and components has been adopted that involves the first three letters of the genus and first letter of the species and, for the allergen component, a number. This scheme has been established to identify each unique allergen extract and component specificity. For instance, Ara h 1 signifies the group 1 allergen in peanut (*Arachis hypogaea*) which is a carbohydrate-bearing 7S vicilin-like globulin.

Allergenic components are adopted into the World Health Organization/International Union of Immunological Societies (WHO/IUIS) Nomenclature committee database once they have an established purity to homogeneity, physical-chemical characterization by molecular weight, isoelectric point and glycosylation pattern, nucleotide and/or amino acid sequence and immunoreactivity to IgE antibody.<sup>8</sup> Allergenic molecules are further classified into protein families according to their structure and function. Different allergenic molecules often share common epitopes which can result in immunological cross-reactivity. Other allergenic molecules can serve as unique

markers for a particular allergen specificity. Examination of the combined protein family (PFAM) database and structural database of allergenic proteins (SDAP) identified approximately 12 000 protein families, of which only approximately 2% or 236 PFAMs are known to contain allergenic proteins. Of these families, 31 protein families contain multiple allergenic proteins (homologs, orthologs). Thus, allergens comprise a small fraction of the total number of protein families and they possess particular biological structures and functions. They tend to be pervasive or abundant in nature and stable to processing (e.g. heat and digestion) as a result of multiple cysteine linkages. They tend to form aggregates or polymers and many tend to be plant defense related. Importantly, not every member of a protein family is allergenic or cross-reactive. Box 18-2 lists the nine principal allergen families that manifest cross-reactivity due to structural similarity. In addition, it presents their principal biological function in nature and illustrative members of these allergen families.

Since 1968, complex physiological extracts of allergenic materials have been used as reagents in serological assays for IgE antibody quantification in serum as they in theory contain all the principal allergenic components for that specificity. There has been increasing interest in the use of native and recombinant component allergens as serological reagents because component resolved diagnosis may better resolve genuine sensitization from cross-reactivity in polysensitized patients. In food allergy, components can be particularly useful for certain foods such as peanut as they can facilitate the assessment of risk for a severe versus more mild allergic reaction and thus reduce the need for an oral food challenge. By identifying the specific components to which an individual is sensitized, more targeted immunotherapy may also be conducted. Thus, instead of measuring IgE antibody to crude cat dander extract, clinically used singleplex and multiplex microarray assays can measure IgE antibody specific to component allergens produced by cats, namely Fel d 1 (uteroglobin), Fel d 2 (cat albumin), Fel d 3 (cystatin), Fel d 4 (lipocalin), Fel d 5 (cat IgA), Fel d 6 (cat IgM) and Fel d 7 (cat IgG). Use of component allergens allows one to dissect more effectively the IgE antibody response into allergen families that share structural homologies and thus cross-react with each other.

Possibly the most well-studied family of cross-reactive allergens is the pathogenesis related proteins (PR10 family) which are present in pollens, pomaceous and stone fruits, vegetables and nuts. These 17 kDa proteins function as ribonucleases and carriers of steroids. Most PR10 proteins are sensitive to heat and digestion. The group 1 allergen from birch tree pollen, Bet v1, has a number of homologs. These include allergenic proteins from alder tree pollen (Aln g 1), hazelnut pollen (Cor a 1), apple (Mal d 1), peach (Pru p 1), soybean (Gly m 4), peanut (Ara h 8), celery (Apr g 1), carrot (Dau c 1) and kiwi (Act d 8). A primary sensitivity to Bet v 1 may result in oral allergy symptoms after exposure to any of these structurally similar allergenic molecules. The chip-based microarray system discussed below is a comprehensive tool for identifying IgE antibodies in a given patient's serum that cross-react with components from seemingly disparate allergen sources.

## Diagnosis of Type 1 Hypersensitivity

The diagnostic algorithm for human allergic disease begins with a thorough clinical history and physical examination. A



**BOX 18-2 PRINCIPAL CROSS-REACTIVE FOOD-AEROALLERGEN FAMILIES**

**Profilin:** An actin-binding protein in tree/grass/weed pollen and foods of plant origin that is involved in the dynamic turnover and restructuring of the actin cytoskeleton (12–15 kDa); sensitive to heat and digestion

Birch ( <i>Betula verrucosa</i> )	Bet v 2
Natural rubber latex ( <i>Hevea brasiliensis</i> )	Hev b 8
Mercury ( <i>Mercurialis annua</i> )	Mer a 1
Timothy grass ( <i>Phleum pratense</i> )	Phl p 12

**Serum albumin:** Protein in milk, blood and epithelia of animals that functions to transport hemin and fatty acids to muscle tissue and maintains oncotic pressure; sensitive to heat and digestion

Cow ( <i>Bos domesticus</i> )	Bos d 6
Dog ( <i>Canis familiaris</i> )	Can f 3
Horse ( <i>Equus caballus</i> )	Equ c 3
Cat ( <i>Felis domesticus</i> )	Fel d 2
Chicken ( <i>Gallus domesticus</i> )	Gal d 5

**Pathogenesis related proteins:** PR10 Family (Bet v 1 homologs)-present in pollens, pomaceous and stone fruits, vegetables and nuts which functions as a ribonuclease and carrier of steroids (17 kDa); most PR10 proteins are sensitive to heat and digestion

Birch ( <i>Betula verrucosa</i> )	Bet v 1–
Hazel pollen ( <i>Corylus avellana</i> )	Cor a 1.010–
Hazelnut ( <i>Corylus avellana</i> )	Cor a 1.040
Apple ( <i>Malus domestica</i> )	Mal d 1
Peach ( <i>Prunus persica</i> )	Pru p 1
Soybean ( <i>Glycine max</i> )	Gly m 4
Peanut ( <i>Arachis hypogaea</i> )	Ara h 8
Kiwi ( <i>Actinidia deliciosa</i> )	Act d 8
Celery ( <i>Apium graveolens</i> )	Api g 1

**Procalcin:** present in weed/grass/tree pollens but not foods that functions to bind calcium and regulate calcium levels; moderately stable

Birch ( <i>Betula verrucosa</i> )	Bet v 4–
Timothy grass ( <i>Phleum pratense</i> )	Phl p 7

**Nonspecific lipid transfer proteins:** present in fruits, vegetables, nuts and pollen which functions to shuttle phospholipids and other fatty acids between cell membranes; stable to heat and digestion (7–9 kDa)

Peanut ( <i>Arachis hypogaea</i> )	Ara h 9
Hazelnut ( <i>Corylus avellana</i> )	Cor a 8
Walnut ( <i>Juglans spp</i> )	Jug r 3
Peach ( <i>Prunus persica</i> )	Pru p 3
Mugwort ( <i>Artemisia vulgaris</i> )	Art v 3
Olive pollen ( <i>Olea europaea</i> )	Ole e 7
Plane tree ( <i>Platanus acerifolia</i> )	Pla a 3

**Lipocalin:** present in furry animals; functions to transport small hydrophobic molecules such as steroids, bilins, retinoids and lipids; stable protein

Cat ( <i>Felis domesticus</i> )	Fel d 4, 7
Dog ( <i>Canis familiaris</i> )	Can f 1, 2, 4, 6

**Parvalbumin:** present in fish and amphibians; binds calcium and is involved in calcium signaling in fast-contracting muscles; stable to heat and digestion

Cod fish ( <i>Gadus morhua</i> )	Gad c 1
Shrimp ( <i>Crangon crangon</i> )	Cra c 4, 6

**Tropomyosin:** Present in crustaceans, mites, cockroaches and nematodes and functions as an actin-binding muscle protein that regulates actin mechanics in muscle contraction; stable to heat and digestion

Anisakis – herring worm ( <i>Anisakis simplex</i> )	Ani s 3
German cockroach ( <i>Blattella germanica</i> )	Bla g 7
Dust mite ( <i>Dermatophagoides pteronyssinus</i> )	Der p 10
Shrimp ( <i>Penaeus monodon</i> )	Pen m 1

**Storage proteins:** present in seeds and nuts; function as nutrient storage (e.g. 2 S albumin) and are stable to heat and digestion

Peanut ( <i>Arachis hypogaea</i> )	Ara h 1, 2, 3, 6
Hazelnut ( <i>Corylus avellana</i> )	Cor a 9
Walnut ( <i>Juglans spp</i> )	Jug r 1, 2
Soybean ( <i>Glycine max</i> )	Gly m 5, 6

suggestive history is followed by in vivo skin testing, in vitro serological assays and/or provocation challenge tests as confirmatory measures for the detection of IgE antibodies (Box 18-3). The inter-relationship between each of these components of the diagnostic plan is illustrated in this chapter using natural rubber latex as a model allergen system.

**CLINICAL HISTORY**

Latex allergy diagnosis begins with a comprehensive clinical history.<sup>9</sup> A child may present with complaints of hives, rhinoconjunctivitis, asthma or anaphylaxis that are temporally associated with exposure to a product that contains natural rubber. The allergist probes the child's general atopic and specific latex allergy history using questions designed to identify predisposing risk factors such as an atopic state (seasonal rhinitis, early-onset asthma, eczema, food allergy), the frequency, consistency and magnitude of latex exposure, the presence of concomitant food allergy and hand dermatitis.<sup>10,11</sup> Exposure to rubber-containing products provides clues which strengthen the clinical suspicion of latex allergy. The rapid onset of allergic

symptoms around toy balloons, dental dams or other dipped rubber products (latex gloves, rubber toys) that contain high levels of allergen is supportive.<sup>12</sup> In contrast, respiratory or upper airway symptoms around latex paint that does not contain natural rubber diminish the likelihood of latex allergy. The type of exposure, time of onset, and duration and severity of the symptoms can help differentiate between an immediate type 1 (protein-allergen induced) and delayed type 4 (rubber chemical induced) hypersensitivity. Finally, a genetic predisposition for atopic disease or parental history of allergy, chronic infectious or acute viral illness, relative contribution of Th1/Th2 cells to the immune response and the nutritional status of the individual are other potential risk factors.

**DIAGNOSTIC LABORATORY METHODS**

Analytes that are measured in the clinical immunology laboratory to support the diagnosis and management of patients suspected of having allergic disease are summarized in Box 18-4. Historically, total serum IgE was used as a diagnostic marker for allergic disease.<sup>13</sup> However, the wide overlap in the total serum

**BOX 18-3 KEY CONCEPTS****Diagnosis**

- Allergen-specific IgE antibody is a marker of allergic sensitization and a risk factor for allergic disease but, alone, it does not make the diagnosis of allergic disease. It is performed as a confirmatory test in support of a clinical history that strongly suggests an allergic disorder.
- Allergen-specific IgE antibody is measured by non-isotopic autoanalyzers that employ a two-stage noncompetitive immunoassay format. In the assay, allergen-specific antibodies are bound to a solid phase allergosorbent and bound IgE antibodies are detected with labeled anti-human IgE. A heterologous total serum IgE calibration curve is used to interpolate response levels into quantitative estimates of allergen-specific IgE.
- Quantitative IgE antibody results are reported in kU<sub>A</sub>/L, traceable to the World Health Organization IgE Reference Preparation (1 U = 2.4 nanograms of IgE).
- The multi-allergen screen is a qualitative assay that measures allergen-specific IgE antibody to multiple aeroallergens and/or food allergens in a single test. The multi-allergen screening assay produces qualitative (positive or negative) results that lead to subsequent investigation of the patient's serum or skin for IgE antibodies specific for individual clinically defined allergen specificities.
- A competitive inhibition format of IgE antibody assays is used to define the relative potency of allergen extracts used in skin testing, to identify the extent of cross-reactivity of human IgE antibody for structurally similar allergens (e.g. vespid vs Polistes wasp venom allergens) and in *Hymenoptera* venom allergy to select appropriate venoms for immunotherapy.
- Quantitative IgE antibody levels to selected foods (milk, egg, fish and peanut) if above a predefined IgE antibody threshold may eliminate the need for tedious and expensive food challenges (DBPCFC). Caution, however, needs to be exercised as the predictive threshold levels vary among clinical studies, due to differences in study populations, protocols and statistical analyses employed.
- Food antigen-specific IgG and IgG4 antibody levels are not diagnostically useful as they do not correlate with the results of oral food challenges.

IgE levels between atopic and nonatopic populations<sup>14</sup> caused it to be superseded by allergen-specific IgE as the single most important laboratory analyte in the diagnostic work-up for allergic disease. Since 2003, all patients receiving anti-IgE therapy (Xolair) must first have a total serum IgE to determine whether or not they are a candidate for the treatment. According to the Xolair indication, if the patient's total IgE falls between 30 and 700 kIU/L, (IU – international unit of IgE which is equivalent to approximately 2.4 nanograms of IgE) then the clinician can use the total serum IgE level to compute the starting Xolair dose using package insert criteria.

The radioallergosorbent test (RAST) was the first assay developed in 1968 for the detection of allergen-specific IgE antibodies in human serum.<sup>15</sup> The RAST is a noncompetitive, heterogeneous (separation step included), solid-phase immunoradiometric (radiolabeled antibody) assay in which allergen is covalently coupled to a solid phase (e.g. cellulose paper disc). In an initial incubation, human serum is added to the allergosorbent, during which time antibodies of all human isotypes, if present, bind to immobilized antigens. Following a buffer wash, bound IgE is detected with <sup>125</sup>I-labeled anti-human IgE Fc. After a second buffer wash to remove unbound radiolabeled

**BOX 18-4 ANALYTES MEASURED IN THE CLINICAL IMMUNOLOGY LABORATORY****DIAGNOSIS**

- Allergen-specific IgE
  - Multi-allergen-specific IgE screen (adult and pediatric forms)
  - Individual allergen specificities (extracts and component allergens)
- Total serum IgE<sup>1</sup>
- Precipitating antibodies specific for proteins in organic dusts
- Tryptase (total and mature) (mast cell protease and used as a marker for mast cell-mediated anaphylaxis)
- Other tests: complete blood count (CBC), sputum examination for eosinophils and neutrophils

**MANAGEMENT**

- Allergen-specific IgG (Hymenoptera)
- Indoor aeroallergen quantitation in surface dust
  - Der p 1/Der f 1 (Dust mite, *Dermatophagoides*)
  - Fel d 1 (Cat, *Felis domesticus*)
  - Can f 1 (Dog, *Canis familiaris*)
  - Bla g 1/Bla g 2 (Cockroach: *Blattella germanica*)
  - Mus m 1 (Mouse: *Mus musculus*)
  - Rat n 1 (Rat: *Rattus norvegicus*)
- Cotinine (metabolite of nicotine measured in serum, urine and sputum and used as a marker of smoke exposure)

**RESEARCH ANALYTES**

- IgE specific autoantibodies
- Eosinophil cationic protein
- Mediators<sup>2,3</sup>
  - Preformed biogenic amine: histamine
  - Newly formed
    - leukotriene C<sub>4</sub> (LTC<sub>4</sub>)
    - prostaglandin D<sub>2</sub> (PGD<sub>2</sub>)
- Proteoglycans<sup>2</sup>
  - Heparin
  - Chondroitin sulfate E
- Proteases<sup>2</sup>
  - Mast cell chymase
  - Mast cell carboxypeptidase
  - Cathepsin G
- Fibroblast growth factor (bFGF)<sup>2</sup>
- Cytokines
  - Tumor necrosis factor (TNF)-alpha
  - Interleukins (ILs) 4, 5, 6, 13<sup>3</sup>

<sup>1</sup>Total serum IgE is the only one of these tests listed that is regulated under the CLIA 88. <sup>2</sup>Primarily released from mast cells. <sup>3</sup>Primarily released from basophils.

anti-human IgE, bound radioactivity is measured in a gamma counter. The counts per minute level associated with the solid phase is proportional to the amount of allergen-specific IgE in the initial serum specimen.

The basic RAST chemistry has remained essentially unchanged for approximately 50 years. However, there have been major advances in assay automation and reagent quality. For instance, the number and quality of allergen extracts and especially component allergens used in preparing allergosorbents have increased as a result of extensive research using new methods of extraction and quality control. The paper disc solid phase in the one current assay (Aligent-Hycor, IgE Turbo-MP) is being replaced by newer matrix materials such as the cellulose sponge (Phadia ImmunoCAP) and biotinylated allergens (Siemens Immulite) that bind to avidin-coated beads. These advances have enhanced the binding capacity and reduced the

nonspecific binding levels of allergosorbents. Various polyclonal and monoclonal anti-IgE detection antibody combinations insure maximal assay sensitivity while maintaining their required specificity for human IgE. Microprocessor-driven automation has improved intra-assay precision and inter-assay reproducibility. Nonisotopic labels have lengthened the shelf-life of immunochemical reagents and have made the assays more user-friendly. The various assays now use a common calibration system in which a (heterologous<sup>16</sup>) total serum IgE curve is used to convert allergen-specific IgE assay response data into quantitative dose estimates of IgE antibody in kU<sub>A</sub>/L units. All these modifications have resulted in assays with superior analytical sensitivity and specificity. They are more quantitative, reproducible and automated than their earlier counterparts. These improvements have made the serological assay for IgE antibody diagnostically competitive with its *in vivo* puncture skin test counterpart. The intradermal skin test still appears to possess an inherent advantage in terms of analytical sensitivity and a major disadvantage involving the loss of diagnostic specificity.<sup>1,17</sup>

A consensus guideline (I/LA20-A3) on allergen-specific IgE assays has been established by an international body of scientists from academia, industry and government regulatory agencies.<sup>18</sup> This effort has led to a more uniform strategy among the various assay manufacturers in reporting IgE antibody results using a common unit (kU<sub>A</sub>/L) with a calibration system that is linked to the World Health Organization IgE reference preparation. In spite of the use of a common calibration scheme, the clinically used assays measure different populations of IgE antibody.<sup>19,20</sup> This observed inter-assay difference is believed to stem from the use of extracts containing different compositions of allergens. The consequence is that published IgE antibody data generated with one assay cannot be directly extrapolated to published predictive outcomes that are based on IgE antibody levels from a second assay method. Specific IgE antibody levels measured in different commercial assays are currently not interchangeable or equivalent.<sup>18</sup>

Until recently, all allergen preparations used in clinical IgE antibody assays have been mixtures of proteins derived from biological extracts of raw material that varies in its composition (molecular weight, charge [isoelectric point], relative content) and allergenic potency as a function of a number of factors. These factors include the season in which the raw material is collected, the degree of difficulty in identifying a pure source of raw material, the presence of morphologically similar raw materials that may cross-contaminate and differences in the allergen extraction process used by different manufacturers. Once prepared, allergen extracts undergo extensive quality control involving isoelectrofocusing, SDS-polyacrylamide gel electrophoresis, crossed immunoelectrophoresis and immunoblotting. Issues of stability during storage, heterogeneity of the human IgE antibody containing quality control sera and different acceptance criteria for extract-based allergen-containing reagents also contribute to inter-method variability. Thus, allergosorbents from different manufacturers can be expected to bind different distributions of IgE antibodies for any given allergen specificity.

Some allergen extracts used in IgE antibody assays have been supplemented with recombinant allergens that are either in low quantity or missing. One successful supplementation involves the crude latex extract in which recombinant Hev b 5 has been added since it is labile and does not survive the extraction from

natural rubber products. The addition of recombinant Hev b 5 by one manufacturer to the latex reagent has increased the diagnostic sensitivity of their latex-specific IgE antibody assay by 10%, with no apparent loss of specificity.<sup>21</sup> However, problems can arise when recombinant protein supplementation of an allergen extract is performed without the knowledge of the clinician who ultimately uses the results in patient management. When hazelnut extract that is used on an allergosorbent was supplemented with recombinant Cor a 1, it caused enhanced detection of IgE antibody to its structurally similar birch pollen homolog Bet v 1.<sup>22</sup> This led to exceptionally high levels of IgE anti-hazelnut in patients with a concomitant birch pollen sensitivity which were challenging to interpret by clinicians.

In 2002, microarray chip technology emerged.<sup>23</sup> Its commercialized version, the ImmunoCAP ISAC or immuno-solid phase allergen chip (ThermoFisher Scientific/Phadia), has 112 native/recombinant component allergens that are spotted in triplicate onto glass slides. Thirty microliters of serum are pipetted onto the chip and antibodies specific for the allergens attached to the chip bind during a 2-hour incubation period. Following a buffer wash, bound IgE is detected with a fluorescently labeled antihuman IgE conjugate. The chip is read in a fluorometer and fluorescent signal units are interpolated into ISU or immuno-solid phase allergen chip (ISAC) units as semi-quantitative estimates of specific IgE antibody in the original serum. The analytical sensitivity of the ISAC varies as a function of the allergen specificity. It is generally less than the ImmunoCAP singleplex system when the same component allergen is coupled to the sponge. The strength of the microarray system is its ability to identify cross-reactivity among structurally similar allergens from different biological substances as noted in [Box 18-2](#). Knowledge of the extent of IgE cross-reactivity must be factored into the diagnostic process within the context of the patient's clinical history.

A point-of-care IgE antibody lateral flow test is a novel alternative IgE antibody assay technology that is used in Europe but has failed to obtain acceptance in North America. In this assay, a drop of whole blood from a finger prick is inserted into the sample well of the cassette. A current commercialized device (ImmunoCAP Rapid, Phadia) allows serum proteins to flow with the fluid front across a nitrocellulose strip that has been impregnated with 10 lines of extract-based aeroallergens (cat dander, *D. farinae*, *D. pteronyssinus*, Bermuda grass, short ragweed, oak tree, *Alternaria*, timothy grass, elm tree and dog dander). If IgE antibody is bound, it is detected with anti-IgE colloidal gold that subsequently migrates up the same nitrocellulose strip following the addition of developing solution to a second well in the cassette. This device is intended for use by primary care physicians who would then refer their IgE-positive patients to an allergist for a comprehensive diagnostic work-up.

### PERFORMANCE OF IgE ANTIBODY CONFIRMATORY TESTS USING A DEFINED POSITIVE CUT-OFF POINT

The practicing medical professional needs to know how well the available IgE antibody confirmatory assays perform analytically and diagnostically. The analytical performance of the available clinical assays is readily defined since they are all calibrated using the same WHO total serum IgE reference preparation. In general, available clinically-used assays detect allergen-specific

IgE antibody down to 0.1 kU<sub>A</sub>/L ( $\approx$ 0.24 ng of IgE) and false positive nonspecific binding typically occurs only with extremely high total IgE levels (e.g. >20 000 IU/mL).<sup>18</sup> Analytical specificity is a function of the quality of the allergen component and anti-IgE used in the assay.

The allergen-specific IgE antibody analysis is a test for allergic sensitization and not for making the definitive diagnosis of allergic disease. Confirmation of allergic sensitization with a positive IgE anti-allergen analysis increases the likelihood that the patient's symptoms may be a result of an immediate type hypersensitivity response. Thus, it is difficult to define the relative 'diagnostic' sensitivity and specificity of IgE antibody assays because these parameters require, first, differentiating individuals who have allergic disease from those who do not have allergic disease. There exists no perfect 'gold standard' method for defining the presence of human allergic disease. The diagnostic algorithm indicates, however, that the clinical history should be the primary decision criterion in making the final diagnosis of allergic disease. Unfortunately, a patient's history is not infallible.

Gendo and Larson have proposed three strategies for defining the presence of human allergic disease, with the expressed purpose of judging the performance of confirmatory IgE antibody tests.<sup>24</sup> The 'clinical criteria gold standard' correlates the patient's symptoms and signs with clinical criteria that have been established by expert opinion. It is easy to use and applicable to most patients but, unfortunately, it is prone to recall bias. Box 18-5 lists the principal patient and medical care professional factors that can influence the accuracy of the clinical criteria based gold standard approach. The 'composite gold standard' combines the clinical history and physical examination information with one or more IgE antibody confirmatory test results (skin tests or serological tests). This approach is generally more robust than just using the history alone, however it tends to overestimate the index test's diagnostic sensitivity and specificity if the index test is a part of the composite gold standard. Box 18-5 lists variables that influence the accuracy of skin test and serological test results. The third and possibly most rigorous strategy for defining the presence of allergic disease is the 'challenge gold standard'. Use of a challenge test to verify the presence of an allergic disease process on the surface sounds ideal. However, it too can be problematic due to differences in threshold of organ sensitivity, a lack of standardization of methods and outcome measures, and the use of a higher allergen dose than is found in nature to elicit a clinically measurable response. Because skin and serological tests and provocation testing are analytical methods, they are inherently variable.<sup>10,18,19,25</sup> Thus, the validity of their results must always be critiqued, especially if inconsistent with the history-based diagnosis.

A number of clinical studies have used one of these three gold standard approaches to define the presence of aeroallergen-related allergic disease.<sup>17,26,27</sup> With the cases defined, the investigators computed the diagnostic sensitivity and specificity of puncture skin tests and/or serological tests for IgE antibody to a limited number of aeroallergen specificities. Since the patient population studied, positive cut-off criteria, reagent sources used and statistical methods varied among the studies, generalized conclusions from the data in these studies are not possible. Within the limits of these studies, the performance of the puncture skin test ranged from 55% to 98% (diagnostic sensitivity) and 70% to 90% (diagnostic specificity) using the clinical or

### BOX 18-5 VARIABLES THAT INFLUENCE THE ACCURACY OF THE ALLERGY DIAGNOSIS

The allergen-specific IgE antibody analysis is a test for allergic sensitization and not for making the definitive diagnosis of allergic disease. Multiple factors also influence the translation of allergen exposure into an allergic symptom.

#### PATIENT FACTORS

Recognition of symptoms: recall bias related missing data, lack of knowledge or ability to accurately describe symptoms  
 Environment: rural, suburban, urban, pet ownership, smoking  
 Extent of allergen exposure: time between exposure and symptom recognition, exposure route (ingestion, inhalation, injection, adsorption)  
 Demographics: age (adult vs child-parent), gender, social economic status, language, race, family history of atopy  
 Prevalence of allergic disease in question in the population

#### MEDICAL CARE PROFESSIONAL FACTORS

Extent of education, training and experience  
 Physical examination skills  
 Questionnaire tools/skills: sensitivity and specificity  
 Differential interpretation of diagnostic test results

#### SKIN TEST FACTORS

Allergen extracts: potency, stability, standardization or characterization, concentration used, irritant in allergen extract, contaminant allergen in extract  
 Technique: puncture, intradermal, skin test device, number of skin tests, reporting scale [0 to 4+] vs mm of wheal/erythema, comparison to saline control or histamine control, skin test spacing application, insufficient penetration of the needle, testing in the week after anaphylaxis  
 Technologist and physician: education, training, experience in grading and interpretation of results  
 Quality control: negative control, positive control  
 Patient: dermographism, interfering premedication (antihistamines, tricyclic antidepressants, long-term oral steroids, topical steroids)  
 System factors: quality assurance practices, records, office procedures, level of documentation of results

#### SEROLOGICAL TEST FACTORS

IgE antibody assay method: analytical sensitivity, degree of automation, method of standardization and quality control, reproducibility, linearity, units  
 Reagents: allergen containing reagent, anti-IgE detection reagent, buffers, protein matrix effects, recombinant allergen supplementation  
 Specimen/allergen specificity factors: specific to total IgE ratio, cross-reactive carbohydrate reactivity, high IgE nonspecific binding levels, allergen heterogeneity (analytical specificity)  
 Technical staff: education, training and experience  
 System factors: laboratory quality control practices, records, office procedures, level of documentation of results, laboratory certification

composite gold standard to identify allergic disease. In the same studies, the performance of the serological tests for IgE antibody with the same allergen specificities ranged from 55% to 80% (diagnostic sensitivity) and 82% to 99% (diagnostic specificity) using the clinical or composite gold standard. Performance improved slightly for both the skin test and serology when a challenge-based gold standard was used to define the presence of clinical disease. In a 2014 comparative study,<sup>26</sup> substantial



discordance was demonstrated between IgE antibody serology and skin testing results performed on the same individuals. The two methods of IgE antibody detection appeared to complement each other and ideally they should not be interpreted interchangeably.<sup>26</sup> Importantly, using the IgE antibody results from either serology or skin testing alone can lead to a misdiagnosis of every fourth allergically sensitized patient as nonsensitized.

For food allergy diagnosis where the skin testing food extracts are highly variable, serological IgE antibody assays may be more reliable and reproducible. If the confirmatory test result is inconsistent with the history-based diagnosis, it should be repeated with the same or an alternative confirmatory test for verification. Both skin and serological tests for IgE antibody are analytical methods with their inherent variability, and thus repetitive confirmation is often needed to minimize error associated with random or systematic bias.

### PERFORMANCE OF IgE ANTIBODY CONFIRMATORY TESTS USING A PROBABILITY OF CLINICAL DISEASE

Current assay technology produces quantitative estimates of IgE antibody in serum as international units per mL that are traceable to the WHO International Reference Preparation for human IgE. Rather than examine the dichotomized IgE antibody data as a positive or negative result using a positive cut-off value, the alternative has been to examine the risk of clinical allergy associated with different IgE antibody levels as a series of probabilities. A 1997 study retrospectively investigated sera from 196 children and adolescents (mean age 5.2 years, 60% male) with atopic dermatitis who were evaluated for food allergy over a 10-year period.<sup>28</sup> Levels of IgE antibodies specific for cow's milk, chicken egg, peanut, wheat, soy and fish were correlated with a diagnosis of food allergy as defined by positive double-blind, placebo-controlled food challenges or a convincing history of food-induced anaphylaxis. They were able to identify IgE antibody levels using the Phadia FEIA CAP system that could predict clinical reactivity (positive food challenges) with >95% certainty for egg (6 kU<sub>A</sub>/L), milk (32 kU<sub>A</sub>/L), peanut (15 kU<sub>A</sub>/L), and fish (20 kU<sub>A</sub>/L). The significance of this report rests in its potential for identifying truly food allergic individuals and thus eliminating the need for food challenges in children suspected of having IgE-mediated food allergy. In a 2001 report,<sup>29</sup> a prospective study was performed with sera from 100 children and adolescents (mean age: 3.8 years, 62% male) who had been referred for evaluation of food allergy. This prospective study verified the retrospective study based on 95% predictive decision points for egg, milk, peanut and fish allergy. The study also confirmed that use of the positive criteria correctly diagnosed food allergy in >95% of children using the serum IgE antibody level. The study showed that quantitative food-specific IgE antibody measurements can be judiciously used to define the probability or risk of symptomatic allergies related to egg, milk, peanut and fish in the pediatric population. The important conclusion of these studies is that careful use of quantitative serological IgE antibody test results may eliminate the need for food challenges in some children.

For inhalant allergies, quantitative cat allergen-specific IgE antibody measurements have been shown to be equivalent to puncture skin tests and superior in performance to intradermal skin tests in the diagnosis of clinical reactivity to cat allergen.<sup>17</sup>

When compared to a positive cat inhalation challenge outcome, IgE antibody levels by the ImmunoCAP system displayed a diagnostic sensitivity of 69%, specificity of 100%, positive predictive value of 100% and negative predictive value of 73%. In the dust mite system, a significant correlation was observed between the concentration of dust mite specific IgE and the concentration of sensitizing mite allergen in the individual's mattress dust ( $P = .001$ ).<sup>30</sup> The authors reported a 77% probability of being exposed to high dust mite allergen (>10 µg per g of dust) when the serum IgE anti-mite levels were greater than 2 kU<sub>A</sub>/L and vice versa. Finally, using specific IgE as a continuous variable, the risk of current wheeze and reduced lung function in children increases significantly with increasing summed measurements of dust mite, cat and dog specific IgE antibody.<sup>31</sup> These data indicate that quantitative estimates of serum IgE antibody can identify individuals who are not only sensitized but also who are in need of avoidance practices which they accomplish through environmental control measures. Other illustrations of the importance of quantitative allergen-specific IgE to respiratory allergy are reviewed elsewhere.<sup>32</sup> As a general rule for inhalant allergen specificities, the skin test and quantitative IgE antibody immunoassay can be viewed as interchangeable. One exception is in the monitoring of patients on immunotherapy where a decrease in the positivity of the puncture skin test titration alone has been shown to predict continued remission after cessation of allergen immunotherapy.<sup>33</sup>

### Multi-Allergen IgE Antibody Screening Assays

When a patient provides an equivocal history for allergic disease, it can be difficult to pinpoint with reasonable certainty the appropriate IgE antibody specificities for further diagnostic investigation. A multi-allergen screen is a single IgE antibody analysis that has the highest negative predictive value for atopic disease of any single laboratory test currently available. Multiple companies have multi-allergen screens which cover a broad number of specificities (e.g. 10–15 common indoor and outdoor aeroallergens that induce most upper and lower airway related allergic disease). Other multi-allergen screens are specifically targeted at a limited number of specific allergens in a group such as the foods (e.g. chicken egg, cow's milk, peanut, soybean, wheat). A negative multi-allergen screen reduces the likelihood that allergic disease is the cause of the child's clinical problems. Multi-allergen screen results are particularly useful in the diagnosis of pediatric allergic diseases where there is a need to detect allergen-specific IgE antibody in serum as a marker for sensitization. For this reason, the biomarkers committee of a National Institute of Health organized workshop on asthma outcomes has recommended that the multi-allergen screen be performed on all participants in asthma clinical trials to define their atopic status.<sup>34</sup>

In one illustrative study,<sup>35</sup> 143 children and adolescent patients were assigned an allergy status (103 positive, 40 negative) based on a combined history, skin prick test and specific IgE antibody (UniCAP, ThermoFisher Scientific/Phadia) to six common inhalants (mite, oak, ragweed, grass, dog, cat and *Alternaria*). The multi-allergen screen (Phadiatop, ThermoFisher Scientific/Phadia) run on these same sera correctly identified the allergy status of all subjects, verifying the diagnostic sensitivity and specificity of Phadiatop in differentiating sensitized individuals from those who are not sensitized to common inhalant allergens.

### Mast Cell Tryptase

Serum levels of tryptase can be useful as a marker of mast cell activation in making the definitive diagnosis of anaphylaxis. Tryptase is a 134 000 Da serine esterase with four subunits, each containing an enzymatically active site.<sup>36</sup> When tryptase becomes dissociated from heparin, it spontaneously degrades into enzymatically inactive monomeric subunits. It is released from activated mast cells in parallel with pre-stored histamine and other newly generated vasoactive mediators. The total pro-tryptase concentration in blood is considered a measure of the mast cell number and it is estimated by subtracting the mature tryptase from the total tryptase concentration. In contrast, mature tryptase levels in blood are considered a measure of mast cell activation.

An enzyme immunoassay is available to measure total tryptase levels in human serum. It uses a capture monoclonal antibody that binds both protryptase and mature tryptase.<sup>37</sup> Mature tryptase is measured with a solid phase noncompetitive immunoassay that uses a mature tryptase specific capture monoclonal antibody. Prior to analysis, tryptase in the blood is converted into an enzymatically inactive form. Total serum tryptase concentrations in healthy (nondiseased) individuals range from 1 to 10 ng/mL (average 5 ng/mL). If baseline total serum tryptase levels exceed 20 ng/mL, systemic mastocytosis should be suspected. A mature tryptase <1 ng/mL is observed in nondiseased individuals and mature tryptase levels >1 ng/mL indicate mast cell activation. For optimal results, blood samples should be collected from 0.5 to 4 hours following the initiation of a suspected mast cell mediated systemic reaction.<sup>38</sup> A peak mature tryptase >10 ng/mL in a postmortem serum suggests systemic anaphylaxis as one probable cause of death. Systemic anaphylaxis induced by an insect sting can produce mature tryptase levels that peak at >5 ng/mL by 30 to 60 minutes after the sting and then decline with a biological half-life of ≈2 hours.<sup>39</sup>

### Serum Markers of Hypersensitivity Pneumonitis

Extrinsic allergic alveolitis or hypersensitivity pneumonitis is an inflammatory reaction involving the lung interstitium and terminal bronchioles.<sup>40</sup> A heavy exposure to antigenic organic dusts (e.g. molds, bird droppings) can induce chills, fever, malaise, cough and shortness of breath within hours of exposure. While histology of the lung lesions indicates that a cell-mediated pathology is involved in hypersensitivity pneumonitis, most individuals have high levels of IgG antibody in their serum to the offending antigen that is used as a marker of the disease. Precipitating IgG antibody specific for antigens in organic dusts has been measured in human serum to support the differential diagnosis of this condition. The classical double diffusion (Ouchterlony) analysis is routinely performed to detect precipitating antibodies in the diagnosis of this disease. In this assay, crude antigen extract and antibody (control or patient's serum) are delivered into closely spaced wells in a porous agarose gel. Visible white precipitin lines confirmed by lines of identity with known human antibody controls are considered a positive test. Precipitating antibodies or precipitins were detected in the serum of nearly all ill patients in one study, but also in the serum of 50% of asymptomatic individuals exposed to the relevant organic dusts.<sup>40,41</sup> More recently, enzyme immunoassays for IgG antibody to selected organic dust antigens have been reported.<sup>42</sup> In many cases, however, the enzyme immunoassay

appears to be too analytically sensitive and diagnostically non-specific. Thus, the classical precipitin assays continue to be widely used for detecting IgG precipitins to antigens in pigeon serum, *Aureobasidium pullulans*, thermophilic actinomyces, *Aspergillus fumigatus* and extractable proteins from fecal material produced by parakeets and a variety of exotic household birds.

## Management of Type 1 Hypersensitivity

The management of individuals with allergic disease involves the combined use of pharmacotherapy, immunotherapy, anti-IgE therapy and avoidance therapy. A number of analytical measurements performed by the clinical immunology laboratory can aid the clinician in optimizing an immunotherapy regimen by monitoring the humoral (IgG antibody) immune responses in patients on venom immunotherapy (Box 18-6). Anti-IgE therapy begins with a total serum IgE to determine proper dosing. Assays to monitor the level of free (non-anti-IgE bound) IgE in circulation of patients on omalizumab have remained research assays<sup>43</sup> as there is currently no documented clinical indication for their use. Finally, indoor aeroallergen levels may be measured in surface reservoir dust before remediation to document the need for and monitor the extent of allergen avoidance measures and after remediation to verify that the environment has been cleaned of allergen sources.

### OPTIMIZING VENOM IMMUNOTHERAPY

When considering the medically important *Hymenoptera*, cross-reactivity has been known to exist between the vespid venoms (yellow jacket, white faced hornet and yellow hornet) and *Polistes* wasp venom proteins. Results from a competitive inhibition format of the *Polistes* wasp venom-specific IgE antibody serology have allowed allergists to select the venom specificities more effectively and to minimize the number of venoms that must be administered during immunotherapy.<sup>44</sup> This targeted venom therapy is especially important for children where unnecessary administration of *Polistes* wasp venom may lead to de novo sensitization to *Polistes* allergens. More recently, component resolved diagnosis using recombinant venom allergens permits more effective identification of cross-sensitization that results from dual sensitization to honeybee and vespid venoms. This allows venom immunotherapy to be performed with the relevant single venom rather than multiple venoms.<sup>45</sup>

### AEROALLERGEN MEASUREMENTS OF INDOOR ENVIRONMENTS TO FACILITATE AVOIDANCE THERAPY

Dust mite (*Dermatophagoides pteronyssinus*, *D. farinae*), cat epithelium/dander (*Felis domesticus*), dog epithelium/dander (*Canis familiaris*), German cockroach (*Blattella germanica*), mouse (*Mus musculus*), rat (*Rattus norvegicus*) and molds are known sources of potent indoor aeroallergens.<sup>46</sup> Allergic proteins from each of these biosources are being used as 'indicator' allergens for relative levels in surface reservoir dust in the home, workplace or school (Box 18-6).

A surface dust specimen is collected from air ducts, floors or other horizontal surfaces (bed, upholstered furniture) using an

**BOX 18-6 KEY CONCEPTS****Management**

- Clinically successful aeroallergen immunotherapy is almost always accompanied by high ( $\mu\text{g/mL}$ ) levels of allergen-specific IgG antibody in serum.
- Quantitative venom-specific IgG antibody levels can be useful in individualizing venom doses and injection frequencies for patients on maintenance venom immunotherapy for up to 4 years.
- Mast cell tryptase is a serine esterase that is used as a marker of mast cell activation during anaphylaxis. Immunoreactive tryptase levels in serum of healthy adults are typically  $<5 \mu\text{g/L}$ . Elevated levels ( $>10 \mu\text{g/L}$ ) are detectable 1 to 4 hours after the onset of systemic anaphylaxis with hypotension.
- Indoor allergens from dust mites, animals (cat, dog, mouse, rat), cockroaches and a limited number of molds are quantified in processed house dust to investigate individual risk for allergic symptoms or sensitization and to monitor effects of environmental control.

inexpensive dust collector that is attached to a standard household vacuum cleaner. Crude dust is sent to a clinical immunology laboratory where it is sieved, extracted and quantified using a monoclonal antibody-based immunoenzymetric assay in plates (ELISA) or on fluorescent beads (BioPlex). A high level of one or more indoor aeroallergens identifies an allergen source that can sensitize or induce an allergic reaction in a sensitized individual. Levels of Der p 1/f 1 allergen  $>2000 \text{ ng/g}$  of fine dust have been associated with an increased risk for allergic symptoms in sensitized individuals. In contrast, cat allergen levels  $>8000 \text{ ng/g}$  of Fel d 1 in fine dust have been suggested as the threshold for sensitization. Comparable risk targets have also been used for dog (Can f 1) allergen levels in indoor environments. For cockroach, mouse and/or rat urinary allergen, any detectable allergen in the indoor environment places cockroach, mouse or rat allergic individuals at risk for symptoms and further sensitization.<sup>47</sup>

**MOLD/FUNGUS EVALUATION IN INDOOR ENVIRONMENTS**

Accurate quantitation of the mold content of an environment is a challenge. *Alternaria*, *Aspergillus*, *Cladosporium* and *Penicillium* comprise the majority of indoor molds.<sup>47</sup> The total spore counts (nonviable and viable) can be determined by collecting particulate from an air impactor or suction device and then assessing the spore's morphology for the purpose of speciating the mold. Viable fungal spores that grow when environmental conditions are favorable are considered by some allergists as more clinically important since they can colonize indoor environments and, in some cases, the respiratory tract. In one clinical laboratory, a qualitative viable mold spore analysis is performed on 5 mg of fine dust that is distributed over a

microbiological culture plate containing Sabouraud's dextrose agar. Visual inspection of the plate at 24 and 48 hours allows the total number of mold colonies to be quantified. The colony count at 24 hours is an estimate of the mold burden of the environment. Repetitive subculturing and morphological identification allows speciation of the predominant molds; however, this is infrequently performed. Rather, once a mold contamination has been identified, remediation by cleaning with bleach and reducing humidity is generally instituted.

There are no established mold spore contamination ranges that can be considered safe, partly because mold is ever present, different individuals have different relative sensitivities and the target airborne mold allergens are difficult to sample and verify. Thus, it is not possible to identify an environment that will place a mold-allergic person at risk for symptoms. Multiple variables associated with mold spore heterogeneity, differential growth based on nutrients and environmental conditions, the degree of aerosolization, and variable specificity of the patient's IgE antibody complicate the interpretation of a mold spore measurement when attempting to predict a clinical outcome from any environmental exposure. Sometimes the indoor mold levels are compared to the outdoor mold levels collected at the same time to judge if airborne mold spores are significantly higher and thus playing a more significant role in the allergy and asthma symptoms experienced indoors. Mold spore levels above 25 000 colonies per gram of fine dust have been identified in one study as a level that places a home in the 75th percentile for random homes monitored across the USA. When this proposed threshold level is exceeded, the allergic individual is encouraged to remediate their environment, which often involves replacing air duct filters, removing plants and decreasing indoor humidity and removing carpeted floors, upholstered furniture and stuffed toys.

**Conclusions**

The diagnostic allergy laboratory exists to provide serological testing that supports the clinician in the diagnosis and management of patients suspected of type 1 hypersensitivity reactions. To this end, the most important analyte measured in the clinical laboratory is allergen-specific IgE antibody. Selection of the laboratory and the IgE antibody assay methods and standards that it employs to insure quality are the ultimate responsibility of the referring physician.<sup>48</sup> Performance on national diagnostic allergy proficiency surveys and successful inspections leading to federal licensure under the Clinical Laboratory Improvement Act of 1988 are benchmarks that can be used by the healthcare professional to insure that the clinical laboratory provides quality diagnostic allergy testing.

The complete reference list can be found on the companion Expert Consult website at <http://www.expertconsult.inkling.com>.

**KEY REFERENCES**

- Christensen LH, Holm J, Lund G, Riise E, Lund K. Several distinct properties of the IgE repertoire determine effector cell degranulation in response to allergen challenge. *J Allergy Clin Immunol* 2008;122:298–304.
- Brieteneder H, Chapman MD. Allergen nomenclature. In: Locky RF, Ledford DK, editors. *Allergens and allergen immunotherapy*. 5th ed. Boca Raton, FL: CRC Press; 2014 [Chapter 3].
- Barbee RA, Halomen M, Lebowitz M, Burrows B. Distribution of IgE in a community population sample: correlations with age, sex and allergen skin tests reactivity. *J Allergy Clin Immunol* 1981;68:106–14.
- Hamilton RG, Matsson PNJ, Sic Chan, Van Cleve M, Hovanec-Burns D, et al. Analytical performance characteristics and clinical utility of immunological assays for human IgE antibodies of defined allergen specificities. 3rd ed. Wayne, PA: Clinical Laboratory Standards Institute; 2015 [Supplement].

20. Hamilton RG. Proficiency survey based evaluation of clinical total and allergen-specific IgE assay performance. *Arch Path Lab Med* 2010;134:975–82.
23. Hiller R, Laffer S, Harwanegg C, Huber M, Schmidt WM, Twardosz A, et al. Microarrayed allergen molecules: diagnostic gatekeepers for allergy treatment. *FASEB J* 2002;16:414–16.
26. De Vos G. Skin testing versus serum-specific IgE testing: which is better for diagnosing aeroallergen sensitization and predicting clinical allergy? *Curr Allergy Asthma Rep* 2014;14:430–8.
29. Sampson HA. Utility of food-specific IgE concentrations in predicting food allergy. *J Allergy Clin Immunol* 2001;107:891–6.
39. Van der Linden PW, Hack CE, Poortman J, Vivie-Kipp YC, Struwenberg A, van der Zwan JK. Insect sting challenge in 138 patients: relation between clinical severity of anaphylaxis and mast cell activation. *J Allergy Clin Immunol* 1992;90:110–18.
45. Golden DB. New directions in diagnostic evaluation of insect allergy. *Curr Opin Allergy Clin Immunol* 2014;14:334–9.
46. Hamilton RG, Chapman MD, Platts-Mills TAE, Adkinson NF Jr. House dust aeroallergen measurements in clinical practice: a guide to allergen free home- and work- environments. *Immunol Allergy Practice* 1992;14:96–112.



## REFERENCES

- Bernstein IL, Li JT, Bernstein DI, Hamilton RG, Spector SL, Tan R, et al. Allergy diagnostic testing: an updated practice parameter. *Ann Allergy Asthma Immunol* 2008;100:S1–148.
- Hamilton RG. Serological (in vitro) testing methods in the diagnosis of human allergic disease. In: Lockey RF, Ledford DK, editors. *Allergens and allergen immunotherapy*. Boca Raton: CRC Press; 2014 [Chapter 8].
- Prausnitz C, Kustner H. Studien über Überempfindlichkeit. *Centralb Bakterial 1 Abt Orog* 1921;86:160–9. Originally published in English in Prausnitz C. In: Gell PGH, Coombs RRA, editors. *Clinical aspects of immunology*. Oxford: Blackwell; 1962. p. 808–16.
- Ishizaka K, Ishizaka T. Physicochemical properties of reaginic antibody. I. Association of reaginic activity with an immunoglobulin other than gamma A or gamma G globulin. *J Allergy* 1967;37:169–72.
- Johansson SGO, Bennich H. Immunological studies of an atypical (myeloma) immunoglobulin. *Immunology* 1967;13:381–94.
- Christensen LH, Holm J, Lund G, Riise E, Lund K. Several distinct properties of the IgE repertoire determine effector cell degranulation in response to allergen challenge. *J Allergy Clin Immunol* 2008;122:298–304.
- Hamilton RG, Saito H. IgE antibody concentration, specific activity, clonality, and affinity measures from future diagnostic confirmatory tests. *J Allergy Clin Immunol* 2008;122:305–6.
- Brieteneder H, Chapman MD. Allergen nomenclature. In: Lockey RF, Ledford DK, editors. *Allergens and allergen immunotherapy*. 5th ed. Boca Raton, FL: CRC Press; 2014 [Chapter 3].
- Hamilton RG, Palosuo T, the American Society for Testing Materials Working Group. Standard test method for immunological measurement of four principal allergenic proteins (Hev-b 1, 3, 5, and 6.02) in natural rubber and its products derived from latex. Report D7427. West Conshohocken, PA: American Society for Testing Materials International; 2008.
- Hamilton RG. Diagnosis of natural rubber latex allergy. *Methods* 2002;27:22–31.
- Hamilton RG, Peterson EL, Ownby DR. Clinical and laboratory based methods in the diagnosis of natural rubber latex allergy. *J Allergy Clin Immunol* 2002;110:S47–56.
- Kostyal D, Horton K, Beezhold D, Lockwood S, Hamilton RG. Latex as a significant source of *Hevea brasiliensis* allergen exposure. *Ann Allergy Clin Immunol* 2009;103:354–5.
- Hamilton RG. Human immunoglobulins. In: Donnenberg AD, O’Gorman M, editors. *Handbook of human immunology*. 2nd ed. Boca Raton: CRC Press; 2008. p. 63–106.
- Barbee RA, Halomen M, Lebowitz M, Burrows B. Distribution of IgE in a community population sample: correlations with age, sex and allergen skin tests reactivity. *J Allergy Clin Immunol* 1981;68:106–14.
- Wide L, Bennich H, Johansson SGO. Diagnosis by an in vitro test for allergen specific IgE antibodies. *Lancet* 1967;2:1105–9.
- Butler JE, Hamilton RG. Quantification of specific antibodies: methods of expression, standards, solid phase considerations and specific applications. In: Butler JE, editor. *Immunochimistry of solid phase immunoassays*. Boca Raton: CRC Press; 1991. p. 173–98.
- Wood RA, Phipatanakul W, Hamilton RG, Eggleston PA. A comparison of skin prick tests, intradermal skin tests and RASTs in the diagnosis of cat allergy. *J Allergy Clin Immunol* 1999;102:773–9.
- Hamilton RG, Matsson PNJ, Sic Chan, Van Cleve M, Hovanec-Burns D, et al. Analytical performance characteristics and clinical utility of immunological assays for human IgE antibodies of defined allergen specificities. 3rd ed. Wayne, PA: Clinical Laboratory Standards Institute 2015 [Supplement].
- Wood RA, Segall N, Ahlstedt S, Williams PB. Accuracy of IgE antibody laboratory results. *Ann Allergy Asthma Immunol* 2007;99:34–41.
- Hamilton RG. Proficiency survey based evaluation of clinical total and allergen-specific IgE assay performance. *Arch Path Lab Med* 2010; 134:975–82.
- Hamilton RG, Rossi CE, Yeang HY. Latex-specific IgE assay sensitivity enhanced using Hev-b 5 enriched latex allergosorbent. *J Allergy Clin Immunol* 2003;111:S174–A424.
- Sicherer SH, Dhillon G, Laughery KA, Hamilton RG, Wood RA. Caution: the Phadia hazelnut ImmunoCAP (f17) has been supplemented with recombinant Cor a 1 and now detects Bet v 1-specific IgE, which leads to elevated values for persons with birch pollen allergy. *J Allergy Clin Immunol* 2008;122:413–14.
- Hiller R, Laffer S, Harwanegg C, Huber M, Schmidt WM, Twardosz A, et al. Microarrayed allergen molecules: diagnostic gatekeepers for allergy treatment. *FASEB J* 2002;16:414–16.
- Gendo K, Larson EB. Evidence based diagnostic strategies for evaluating suspected allergic rhinitis. *Ann Intern Med* 2004;140:278–89.
- McCann WA, Ownby DR. Reproducibility of the allergy skin test scoring and interpretation by board-certified/eligible allergists. *Ann Allergy Asthma Immunol* 2002;89:368–71.
- De Vos G. Skin testing versus serum-specific IgE testing: which is better for diagnosing aeroallergen sensitization and predicting clinical allergy? *Curr Allergy Asthma Rep* 2014;14: 430–8.
- Williams PB, Dolen WK, Koepke JW, Seiner JC. Comparison of skin testing and three in vitro assays for specific IgE in the clinical evaluation of immediate hypersensitivity. *Ann Allergy* 1992;68:34.
- Sampson HA, Ho DG. Relationship between food-specific IgE concentrations and the risk of positive food challenges in children and adolescents. *J Allergy Clin Immunol* 1997;100:444–51.
- Sampson HA. Utility of food-specific IgE concentrations in predicting food allergy. *J Allergy Clin Immunol* 2001;107:891–6.
- De Lovinfosse S, Charpin D, Dornelas A, Domelas A, Birbaum J, Vervollet D. Can mite specific IgE be used as a surrogate marker for mite exposure? *Allergy* 1994;49:64–9.
- Simpson A, Soderstrom L, Ahlstedt S, Murray CS, Woodcock A, Custovic A. IgE antibody quantification and the probability of wheeze in preschool children. *J Allergy Clin Immunol* 2005;116:744–9.
- Yunginger JW, Ahlstedt S, Eggleston PA, Homburger HA, Nelson HS, Ownby DR, et al. Quantitative IgE antibody assays in allergic diseases. *J Allergy Clin Immunol* 2000;105: 1077–84.
- Des Roches A, Paradis L, Knani J, Hejiaoul A, Dhivert H, Dhanez P, et al. Immunotherapy with a standardized Dermatophagoides pteronyssinus extract. V. Duration of the efficacy of immunotherapy after its cessation. *Allergy* 1996;51:430–3.
- Szefer SJ, Wenzel S, Brown R, Erzurum SC, Fahy JV, Hamilton RG, et al. Asthma outcomes: biomarkers. *J Allergy Clin Immunol* 2013;19: S9–23.
- Williams PB, Siegel C, Portnoy J. Efficacy of a single diagnostic test for sensitization to common inhalant allergens. *Ann Allergy Asthma Immunol* 2001;86:196–202.
- Schwartz LB, Bradford TR. Regulation of tryptase from human lung mast cells by heparin. Stabilization of the active tetramer. *J Biol Chem* 1986;261:7372–9.
- Enander I, Matsson P, Andesson AS, Nystrand J, Andesson AS, Eklund E, Bradford TR, et al. A radioimmunoassay for human serum tryptase released during mast cell activation. *J Allergy Clin Immunol* 1990;85:154–9.
- Schwartz LB, Yunginger JW, Miller J, Bokhari R, Dull D. Time course of the appearance and disappearance of human mast cell tryptase in the circulation after anaphylaxis. *J Clin Invest* 1989;83:1551–5.
- Van der Linden PW, Hack CE, Poortman J, Vivie-Kipp YC, Struvenberg A, van der Zwan JK. Insect sting challenge in 138 patients: relation between clinical severity of anaphylaxis and mast cell activation. *J Allergy Clin Immunol* 1992;90:110–18.
- Zacharisen MC, Schuleter DP, Kurup VP, Fink JN. The long-term outcome in acute, subacute and chronic forms of pigeon breeder’s disease hypersensitivity pneumonitis. *Ann Allergy Asthma Immunol* 2002;88:175–82.
- Fan LL. Hypersensitivity pneumonitis in children. *Curr Opin Pediatr* 2002;14:323–6.
- Mizobe T, Adachi S, Hamaoka A, Andoh M. Evaluation of the enzyme-linked immunosorbent assay system for serodiagnosis of summer-type hypersensitivity pneumonitis. *Arerugi* 2002;51:20–3.
- Baker DL, Peng K, Cheu M, Fischer SK. Evaluation of two commercial Omalizumab/free IgE immunoassays: implications of use during therapy. *Curr Med Res Opin* 2014;30: 913–22.
- Hamilton RG, Wisenauer JA, Golden DB, Valentine MD, Adkinson NF Jr. Selection of Hymenoptera venoms for immunotherapy on the basis of patient’s IgE antibody cross-reactivity. *J Allergy Clin Immunol* 1993;92:651–9.
- Golden DB. New directions in diagnostic evaluation of insect allergy. *Curr Opin Allergy Clin Immunol* 2014;14:334–9.
- Hamilton RG, Chapman MD, Platts-Mills TAE, Adkinson NF Jr. House dust aeroallergen measurements in clinical practice: a guide to allergen free home- and work- environments. *Immunol Allergy Practice* 1992;14:96–112.
- Hamilton RG, Eggleston PA. Environmental allergen analyses. *Methods* 1997;13:53–60.
- Hamilton RG. Responsibility for quality IgE antibody results rests ultimately with the referring physician. (Invited editorial). *Ann Allergy Asthma Immunol* 2001;86:353–5.

# In Vivo Testing for Immunoglobulin E-Mediated Sensitivity

HAROLD S. NELSON

## KEY POINTS

- Skin testing is the preferred method for in vivo detection of IgE-mediated sensitivity due to its objective end-point and the ability to test for multiple sensitivities in one session.
- Positive skin tests are present in most patients with asthma and allergic rhinitis but are also common in subjects without symptoms. Therefore the presence of a positive skin test is not sufficient to make a clinical diagnosis of allergy.
- Some patients have typical symptoms of allergic rhinitis but negative skin and in vitro tests for the relevant allergens. This local nasal allergy can be confirmed by the presence of a positive nasal challenge with the allergen.
- Positive skin tests are most common and largest in subjects in the third decade. They are considerably less common and smaller in young children and older adults.
- Prick/puncture skin tests are less sensitive than intradermal tests with the same concentration of extract but they correlate better with clinical symptoms caused by inhalant allergens.

## Introduction

In the USA, in vivo testing for the diagnosis of allergy is virtually synonymous with skin testing. The preference for skin testing over allergen challenges to the conjunctiva, nose or lungs is attributable to skin testing being less time consuming and more comfortable for the patient. It provides an objective end-point, rather than the subjective end-points typical with conjunctival and nasal challenges. Finally, many allergens can be tested for in a single session, compared to the limitation to a single allergen with mucosal challenges. There is little to suggest that the information gained from mucosal testing is different from that obtained by skin testing. Results of nasal challenges have been shown to correlate closely with skin tests,<sup>1</sup> as do the results of bronchial challenges, when the additional factor of nonspecific airway responsiveness to histamine is included.<sup>2</sup> A joint committee of the American Academy of Allergy, Asthma and Immunology and the American College of Allergy Asthma and Immunology has developed a Practice Parameter for Allergy Diagnostic Testing which is comprehensive and based on the most current published literature on this topic.<sup>3</sup>

## Prevalence of Positive Skin Tests

Reaction of the skin to extracts of environmental allergens is common, but not invariable, in patients with the so-called 'atopic diseases' – perennial and seasonal rhinitis, bronchial asthma and atopic eczema. Of 656 asthmatic patients referred for an allergy evaluation in London, 544 (84%) had at least one positive immediate reaction to prick skin testing with 22 common allergens.<sup>4</sup> Skin test reactivity was more common in those with onset of asthma prior to 10 years of age, whereas those with onset after the age of 30 years were more commonly skin test negative. A similar percentage with positive skin tests has been reported in patients evaluated for rhinitis<sup>5</sup> and eczema.<sup>6</sup>

Positive reactions on skin testing are also common in studies of unselected residents in westernized societies and there is a suggestion that the prevalence is increasing, including in the USA.<sup>7</sup> Allergy skin testing was administered in the second and third National Health and Nutrition Examination Survey (NHANES) from 1976 to 1980 and 1988 to 1994. In NHANES III, 10 allergens were tested in all subjects aged 6 to 19 years and a random half-sample of subjects aged 20 to 59 years. In NHANES III, 54.3% had a positive prick skin test to one or more allergens. Among those with positives, the median number was 3.0. For the six allergens common to NHANES II and III, prevalences were 2.1 to 5.5 times higher in NHANES III and the percentage of sensitized subjects increased in all age groups. Although the extracts were not identical, it is likely that the pollen extracts, at least, were of comparable strength.

It is clear that these positive reactions are not limited to persons with clinical allergy. A study was conducted in 200 young and middle-aged adults, employing a battery of 13 extracts (10 pollens, 2 mites and cat).<sup>8</sup> Three groups were recruited for prick skin testing. In those with a personal history of rhinitis or asthma, 90% had at least one positive prick skin test. In those with no personal history of rhinitis or asthma, but a close relative with one of these conditions, 46% had at least one positive prick skin test. Even in those who denied rhinitis or asthma personally, or in close relatives, 29% had at least one positive prick skin test.

## Factors Affecting the Size and Prevalence of Positive Skin Tests

### AGE

Epidemiological studies in Tucson demonstrated the varying prevalence of positive immediate prick skin test reactions with age in their population.<sup>9</sup> When tested with a battery of five allergens or mixes, only 22% of those who were 3 and 4 years

old had at least one positive test. The peak prevalence of reactivity was seen in the first half of the third decade, when 52% reacted to at least one test. The prevalence of a positive skin test then declined slowly until the age of 50 years, following which there was a more rapid fall-off, reaching a low of 16% in the subjects over 75 years of age. Further studies in this population related the presence of prick skin test reactivity to the reactivity of the skin to histamine and to the serum total immunoglobulin E (IgE) levels.<sup>10</sup> Dividing the population studied into four age groups, they found that total IgE was highest in those who were 9 to 19 years of age and declined progressively in the other three groups (20 to 34, 35 to 50, and over 50 years). Histamine reactivity in the skin was lowest in the 9- to 19-year-old group, however, and was higher in the three older groups. The prevalence of positive skin tests, reflecting in part the interaction of specific IgE and reactivity of the skin to histamine, was highest in the 20- to 34-year-old group.

The evolution of skin prick test reactivity was followed in a birth cohort on the Isle of Wight.<sup>11</sup> The prevalence of a positive prick skin test to any allergen was 19.7% at age 4 years, 26.9% at age 10 years and 41.3% at age 18 years. In Sweden, 664 adults (age 20 to 60 years) were prick skin tested.<sup>12</sup> The highest prevalence of positive prick skin tests was 55% in those 20–29 years of age and the lowest prevalence was 26% in those 50 to 60 years of age. When they repeated the prick skin tests 10 years later, the yearly incidence of any newly positive prick skin test was 0.5% while the rate of conversion of prick skin tests from positive to negative was 3.2% per year.

Supporting data for the above observations come from separate studies of levels of specific IgE and cutaneous reactivity to histamine by age.<sup>13,14</sup> A retrospective review was conducted of results in 326 patients whose serum was analyzed for total and specific IgE.<sup>13</sup> The highest levels for grass and house dust mite-specific IgE were observed in those who were 10 to 15 years of age. A prospective study of cutaneous reactivity to histamine was conducted in 365 subjects from 1 to 85 years of age.<sup>14</sup> The size of the prick skin test to histamine increased progressively, peaking in those who were 21 to 30 years of age. There was then very little difference until the age of 50 years. Following this, there was a decline in the mean reaction size. Representative values with the 27 mg/mL concentration of histamine were: age 0 to 3 years, 3.8 mm; age 21 to 30 years, 6.2 mm; and age 61 to 70 years, 4.5 mm.

Reactivity of the skin to histamine and codeine was examined in children from infancy to the age of 2 years.<sup>15</sup> Prick skin tests with both histamine and codeine (a nonimmunologic mast cell degranulating agent) were particularly small up to the age of 6 months, although after 1 month of age there was usually some reactivity to both reagents. Due to the reduced reactivity to histamine in children under 2 years, adjustment of the interpretation for the size of the positive histamine control is important.

Varying reactivity to histamine can have a significant effect on skin test reactions, even in adults.<sup>16</sup> In an epidemiological study, 893 adult subjects were prick skin tested with 14 allergens and 10-fold dilutions of histamine, ranging from 1 mg/mL to 0.001 mg/mL. In those positive only to the highest concentration of histamine, 56% had all negative skin tests to allergens and only 15% had six or more positive skin tests. By comparison, of those responding to 0.01 and 0.001 mg/mL histamine concentrations, only 11% had all negative skin tests to allergens and 60% had six or more positive tests.

## PHYSIOLOGIC FACTORS

The size of the reaction of the skin has been reported to vary with the time of day, the season of the year, the menstrual cycle, the subject's handedness and with the part of the body used for testing. Although it had been reported that there was a circadian pattern to skin reactivity, a study of 20 children and 20 adults did not find any significant variation during the normal clinic hours.<sup>17</sup> Subjects were tested in duplicate with serial dilutions of short ragweed and histamine at 8 a.m. and 4 p.m. No significant differences between the two sessions were observed at any dilution of either test material. The size of the skin reactions to histamine and allergens was examined over the course of a year.<sup>18</sup> It was found that reactions to both allergens and histamine were greater in October and February than in July and August.

Fifteen allergic women with seasonal rhinitis and/or asthma and 15 nonallergic female controls were skin tested three times during their menstrual cycle.<sup>19</sup> There were significantly greater reactions to histamine and morphine in both allergic and nonallergic women and to *Parietaria* extract in allergic women on days 12 to 16 of the cycle, corresponding to ovulation and peak estrogen levels. The size of the reaction to histamine on the forearms was compared with handedness in 176 subjects.<sup>20</sup> Significant differences between the size of the wheal and flare on the two forearms were observed. Subjects who were right-handed, with only right-handed relatives, had significantly larger reactions on the left arm. Subjects who were either left-handed or ambidextrous had significantly larger reactions on the right arm.

## REACTIVITY OF THE SKIN IN DIFFERENT AREAS OF THE BODY

The back is commonly used for percutaneous testing, since it provides a large surface that can accommodate many tests. Although it may be acceptable to consider the back as homogeneous for clinical purposes, there is a significant gradient of reactivity, with the upper back being less reactive than the middle, which in turn is less reactive than the lower third. The wheal diameter with allergens was 30% less and with histamine 19% less on the upper compared with the lower back.<sup>21</sup> Often the forearm is employed as an alternative site for percutaneous testing because there is no need for the patient to disrobe and testing may be done with the patient sitting in a chair rather than lying down. It has been long recognized that the forearm is not as reactive as the back. In one study, allergen-induced wheal diameter was 27% smaller and flare diameter 14% smaller.<sup>22</sup> While the difference is not great, it is estimated that 2.3% of tests positive on the back would be negative if performed on the forearm.<sup>22</sup>

## VIRAL INFECTIONS

Skin testing with inhalant allergens was performed in 16 adults before and up to 21 days following experimental inoculation with respiratory syncytial virus (RSV).<sup>23</sup> Even subjects with no measurable skin test reactions at baseline showed increased wheal and flare areas in response to histamine and allergen skin tests after RSV infection. The altered skin test response persisted for up to 21 days after RSV inoculation. It was suggested that up-regulation of pathways relating to neurogenic inflammation may have played a role.

**MEDICATION** (see Table 19-1)

Histamine is a major mediator of the immediate skin test, so drugs that have antihistaminic properties suppress skin test reactions. Studies have assessed the duration of this suppression after the medication is discontinued, since this is often an important consideration for diagnostic allergy skin testing. Persisting suppression after multiple doses of first generation antihistamines was studied.<sup>24</sup> The mean time for skin reactivity to return to normal after stopping the drug was 3 days for chlorpheniramine and tripelemamine and 5 days for hydroxyzine. However, some patients remained suppressed for 6 to 8 days. After a single dose of the second-generation antihistamine, fexofenadine, skin reactivity had returned to normal after 24 hours.<sup>25</sup> Single 25 mg doses of the tricyclic antidepressants, desipramine and doxepin, produced suppression which lasted an average of 2 and 6 days respectively.<sup>26</sup> It was recommended that doxepin be withheld at least 7 days before skin testing. Multiple dosing of the H<sub>2</sub> antagonist, ranitidine, produced significant suppression of both the wheal and flare of the histamine skin test.<sup>27</sup> Suppression was only 18% of the mean diameter, so withholding the drug on the day of testing should be adequate.

In 15 subjects, the leukotriene receptor antagonist, montelukast, significantly reduced the flare reaction to histamine, codeine and allergen.<sup>28</sup> There was a nonsignificant trend toward reduction in wheal size with all three agents. Other investigators found nonsignificant reductions in both wheal (9.6%) and flare (7.3%) following administration of montelukast.<sup>29</sup>

There is no consensus regarding the effect of corticosteroids on allergy skin tests. In a prospective study, topical application of corticosteroids for 4 weeks reduced the area of the allergen-induced wheal by 72% and the flare by 62%.<sup>30</sup> The reduction could at least, in part, be explained by an 85% reduction in the number of detectable skin mast cells in the treated skin. A prospective study of 1 week of oral corticosteroids, 24 mg daily of methylprednisolone, found no effect on reactivity to ragweed.<sup>31</sup> A retrospective analysis of 25 patients who had been on oral steroids for longer, but varying periods, suggested that they had diminished skin reactivity to codeine, a nonimmunologic mast cell degranulating agent.<sup>32</sup> However, a prospective study of 33 patients who received oral steroids for at least 1 year (median dose 20 mg of prednisone per day, median duration of 2 years) revealed no suppression of skin reactions to either codeine or allergen.<sup>33</sup>

The monoclonal antibody against IgE, omalizumab, has been reported to reduce skin test reactions.<sup>34</sup> In 19 subjects with perennial allergic rhinitis, 3 months of treatment with omalizumab 0.030 mg/kg/IU/mL reduced free IgE levels >98% and the cumulative whealing response to titrated prick skin tests (150–10 000 AU/mL of house dust mite extract) by 78–83%.

Allergy immunotherapy has been observed to reduce the immediate reaction to allergen skin testing.<sup>35</sup> The reductions in the immediate skin test are accompanied by reductions in nasal and conjunctival sensitivity.<sup>35</sup> Allergen immunotherapy reduces the late cutaneous reaction even more than the immediate.<sup>36</sup>

**QUANTITY AND QUALITY OF EXTRACTS**

The size of the reaction is a function of the patient's sensitivity and the amount of the relevant allergen injected. The relationship between dose and response is best expressed as a log : log relationship.<sup>37</sup> The slope is steeper when the size of the reaction is expressed as the log of the area, as opposed to the log of the diameter. When log-linear dose responses are calculated, the resulting curve is S-shaped, but linear in the midrange.<sup>38</sup> A 10-fold increase in the concentration of allergen or histamine will produce approximately a 1.5-fold increase in mean diameter<sup>37</sup> or a doubling of the area of the wheal.<sup>37</sup>

In the USA, standardized extracts are available for several grasses, ragweed, *Dermatophagoides pteronyssinus* and *farinae*, and cat. In general, other pollen extracts, although not standardized, are of good potency. Most extracts of dog dander,<sup>39</sup> probably most or all fungi<sup>40</sup> and all extracts of cockroach<sup>41</sup> are relatively weak. In the case of fungi and cockroach, proteases in the extracts may degrade susceptible proteins within the extract.<sup>42</sup> One exception to the low potency of most dog extracts is the acetone-precipitated dog extract manufactured by Holister-Steir (Spokane, WA). This extract contains 30 to 40 times as much major allergen as the other commercially available dog extracts. The increased allergen content has been shown to result in an increased number of positive prick skin tests in comparative skin testing.<sup>39</sup>

A unique problem appears to exist with extracts of some foods. Many patients with documented food sensitivity will fail to react to commercial extracts or in vitro tests prepared from these extracts but will react to testing with fresh extracts of the foods.<sup>43–46</sup> Reactions to fresh foods, but not commercial food

**TABLE 19-1** Inhibitory Effect of Various Treatments on Skin Prick Tests

Treatment	Degree	Duration	Clinical Significance
H <sub>1</sub> antihistamine	++++	2–7 days	Yes
H <sub>2</sub> antihistamine			None
H <sub>1</sub> antihistamine	0–+		None
Imipramines	++++	Up to 21 days	Yes
Phenothiazines	+ to ++	Up to 10 days	Yes
Systemic	0		None
Long-term inhaled	0		None
Topical skin	+ to ++	Up to 7 days	Yes
Dopamine	+		None
Clonidine	++		None
Montelukast	0		None
Allergen immunotherapy	0 to ++		None
UV light treatment (PUVA)	+++	Up to 4 weeks	Yes

Modified from Bousquet J, et al. Practical guide to skin prick tests in allergy to aeroallergens. *Allergy* 2011;67:18–24.



extracts, have been reported with fruits and celery,<sup>44,45</sup> with shellfish and fish,<sup>44,46</sup> and even with peanuts and walnuts.<sup>44</sup> This report notwithstanding, peanut extracts have been reported to be reliable in other studies.<sup>45,47</sup> In 76 children aged 5 months to 15 years, there were 31 positive blinded food challenges out of 96 foods which yielded positive prick skin tests.<sup>47</sup> All the positive challenges were to peanuts, eggs, milk or soy. There were no positive open feeding challenges to foods that had not been positive on prick skin testing.

## Methods of Skin Testing

### PRICK VERSUS INTRADERMAL TESTING

There are two approaches to allergen skin testing. One is percutaneous introduction of the allergen through a break in the skin by pricking, puncturing or scratching.<sup>48</sup> In the last of these, a linear scratch is made without drawing blood. The scratch may be performed first with the extract then dropped on the abraded skin, or the scratch may be made through a drop of extract. The scratch test has now largely been abandoned due to greater discomfort, poorer reproducibility and the possibility of leaving multiple linear depigmented areas for some time afterward.<sup>49</sup> The prick test is performed by introducing the tip of the device into the epidermis at approximately a 45-degree angle through a drop of extract; the tip is then lifted, creating a small, transient break in the epidermis. Prick testing can be performed with either solid needles or hollow hypodermic needles. Puncture testing is performed by pressing the tip of the device at a 90-degree angle to the skin. Usually the device employed has a sharp point approximately 1 mm long, with a widening above to limit penetration into the skin.

The alternative to percutaneous testing is intracutaneous testing. A hypodermic syringe and needle is employed. The needle is threaded into the dermis where, typically, 0.01 to 0.02 mL of extract is injected. Intradermal testing is more sensitive than prick/puncture. For equivalent reactions at threshold-sized reactions, the extract for prick/puncture testing must be 1000-fold more concentrated.<sup>48</sup> Also, direct comparisons indicate that intradermal testing is more reproducible than percutaneous testing.<sup>48</sup> Nevertheless, there are many arguments in favor of the percutaneous test as the routine for allergy testing. These include economy of time, patient comfort and safety. These apply to percutaneous versus intracutaneous, no matter what relative concentrations of extract are employed. If, in addition, the intradermal test is performed with a concentration greater than 1:1000 that of the percutaneous test, in order to increase its sensitivity, additional considerations arise as to whether this increased sensitivity is clinically necessary or useful.

### DIAGNOSTIC USEFULNESS OF THE PERCUTANEOUS TEST

The prick skin test has served well in epidemiological studies. Prick skin test reactivity to indoor allergens, but not pollens, has been shown to be a risk factor for asthma in children<sup>50,51</sup> and adolescents and adults.<sup>52</sup> Prick skin test reactivity in asymptomatic freshmen in college carried an increased risk for development of allergic rhinitis.<sup>53,54</sup> Three-year follow-up revealed that 18.2% of those with positive prick skin tests had developed allergic rhinitis compared to 1.8% of those with negative prick skin tests.<sup>53</sup> At 7-year follow-up, 31.9% of those with positive

prick skin tests and 7.7% of those with negative skin tests had developed allergic rhinitis.<sup>54</sup> The larger the prick skin test as a freshman, the more likely the development of allergic rhinitis. Furthermore, after 7 years, new-onset asthma had developed in 5% of the prick skin test positive group, versus 1.5% in the skin test negative group.<sup>54</sup>

### DIAGNOSTIC USEFULNESS OF THE INTRACUTANEOUS TEST

Although the intracutaneous test, at the strength customarily performed, is more sensitive, it may be questioned whether this increased sensitivity is clinically necessary. The prick skin test, performed with good quality extracts, is positive in many subjects who do not have a personal or even a family history of allergy.<sup>8</sup> A number of studies have addressed the clinical usefulness of intracutaneous testing. In the Tucson epidemiological study, 311 subjects had prick skin testing followed, if negative, by intracutaneous testing with 1:1000 w/v extract to 14 common allergens.<sup>55</sup> Subjects were divided, by history, into allergic and nonallergic groups. Prick test reactivity correlated with the presence of allergy symptoms. Conversely, positive reactions to intracutaneous testing, which followed a negative prick test for that allergen, showed no correlation with either the patient's clinical allergic status or the level of total serum IgE. Studies in smaller groups of patients have supported these epidemiological data.

Two studies examined the intracutaneous test as a predictor of symptoms with natural exposure to the allergen.<sup>56,57</sup> In a study of the clinical usefulness of intradermal skin tests to grass, four groups were compared: three of the groups had a history of seasonal allergic rhinitis, one with positive prick skin tests to timothy, one with negative prick but a positive intradermal test to timothy, and one with both prick and intracutaneous tests to timothy negative. The fourth group was a nonallergic control.<sup>56</sup> On the basis of nasal challenge with timothy, grass pollen allergic reactions were present in 68% of those with positive prick skin tests to timothy and none of the nonallergic controls. In both the group with positive and those with negative intracutaneous tests to timothy, 11% were positive. Subjects were then followed through the grass pollen season. Their symptom scores, recorded in a diary, were examined for a correlation with grass pollen counts. A positive correlation was present in 64% of those with positive skin prick tests and none of the nonallergic controls. A positive correlation of symptoms and pollen count was present in 22% of those with a positive intracutaneous test and 21% of those with a negative intracutaneous test to timothy. Both criteria for allergy to timothy, a positive nasal challenge and a correlation between symptoms and grass pollen counts, were met in 46% of those with positive prick skin tests, but in none in the other three groups. Thus, under the conditions of this study, the presence of a positive intradermal skin test response to timothy in the presence of a negative prick skin test response to timothy did not indicate the presence of clinically significant sensitivity to timothy grass.<sup>56</sup>

In the second study, subjects were challenged with cat exposure for 1 hour.<sup>57</sup> Both positive prick skin tests and RASTs to cat were highly predictive of development of symptoms on exposure to the cat room. Subjects with a negative prick skin test were just as likely to have a positive challenge result if they had a negative (31%) as if they had a positive intracutaneous skin test to cat (24%). The authors concluded that, at least with regard to cat allergy, these results strongly suggest that major

therapeutic decisions such as environmental control or immunotherapy should never be based on a positive intracutaneous skin test result alone.<sup>57</sup>

It is clear from these studies that the intradermal skin test adds little to the diagnostic evaluation of allergy when allergy extracts of reasonable quality are available for skin testing. This probably includes almost all pollen extracts, house dust mite, cat and acetone-precipitated dog extracts. What of the extracts of poorer quality, particularly cockroach, fungi and some dander extracts? A study of the diagnosis of allergy to mouse extract is informative in this regard.<sup>58</sup> In this study, 49 workers reported symptoms on mouse exposure. The mouse extract contained only 2.37 µg of Mus m 1 per mL, about 6% the major allergen content in cat extract. Using a nasal challenge as the gold standard, sensitivity was only 47% for measurement of mouse IgE (mIgE), 67% for the prick skin test, and 100% for an intradermal test at a 1:100 dilution of the extract. On the other hand, specificity was 91% for mIgE, 94% for prick skin test, but only 65% for intradermal testing. The prick skin test performed best, but with this weak extract, intradermal testing was required to identify some clinically sensitized workers.

### EXPRESSING THE RESULTS OF SKIN TESTING

The results of both percutaneous and intracutaneous skin tests are often reported in only semi-quantitative terms. Results may be recorded only as positive or negative, or graded 0 to 4+ without any indication of what size reactions these numbers represent.<sup>59</sup> At the very least, a record of skin testing should indicate certain information that will allow another physician to interpret the results. In addition to the concentration of extract employed, the form should indicate whether the tests are percutaneous or intracutaneous and, if the former, which device was employed for testing, whether testing was performed on the back or the arm, and the size of the positive and negative reactions. Finally, if an arbitrary grading system is employed, the range of reaction for each grade should be clearly indicated on the form (see Table 19-2).

A superior method of expressing results is to measure and record actual size of the reaction. This need not be excessively time consuming. Although the area of the wheal is the most accurate, measurements of the product of the orthogonal diameters, the sum of the orthogonal diameters and even the longest diameter correlate very well with area, with *r* values greater than 0.9.<sup>60</sup> In fact, the longest diameter has been reported to correlate better with the wheal area than the mean of two perpendicular diameters.<sup>61</sup> An additional advantage of measuring the diameter of the wheal is the observation that, with 17 of 18 standardized extracts, the risk of having allergic symptoms increased significantly with larger wheal diameter.<sup>62</sup>

The Scandinavian Society of Allergology recommended that skin test results be standardized in relation to the size of the reaction to histamine, employing 0.1 mg/mL of histamine for intradermal testing and 1 mg/mL of histamine for prick skin testing.<sup>63</sup> If the diameter of the reaction to allergen was the same size as the histamine reaction, the grade was 3+, if half that size 2+, and if twice as large 4+. A subsequent study suggested that the histamine control should be 10 mg/mL, because of the small reactions with high coefficient of variation with the 1 mg/mL histamine prick skin test.<sup>64</sup> Even the 20–30% coefficient of variation for reactions to 10 mg/mL raises questions regarding the desirability of basing grading on a histamine control, which,

**TABLE 19-2** Semiquantitative Reporting of Skin Test Results

CRITERIA TO READ PRICK/PUNCTURE SKIN TESTS		
Negative	0	No reaction or no different from control
One plus	+	Erythema < a nickel in diameter
Two plus	++	Erythema > a nickel in diameter
Three plus	+++	Wheal with surrounding erythema
Four plus	++++	Wheal with pseudopods and surrounding erythema
CRITERIA TO READ INTRACUTANEOUS TESTS WHEN CONTROL ≥ 2 MM		
Negative	0	No different from control
One plus	+	Wheal 1½ to 2 times control or definite erythema > a nickel in size
Two plus	++	Wheal 2–3 times control
Three plus	+++	Wheal >3 times control
Four plus	++++	Wheal with pseudopods
CRITERIA TO READ INTRACUTANEOUS TESTS WHEN CONTROL < 2 MM		
Negative	0	No difference from control
One plus	+	3–4 mm wheal with erythema or erythema > a nickel in size
Two plus	++	4–8 mm wheal without pseudopods
Three plus	+++	>8 mm wheal without pseudopods
Four plus	++++	Wheal with pseudopods and erythema

Modified from Vanselow NA. In: Sheldon JM, et al, editors. *A Manual of Clinical Allergy*. 2nd ed. WB Saunders; 1967.

if used for this purpose, should be performed at least in duplicate.<sup>65</sup>

The reliability of different means of expressing the results of prick skin testing was compared in patients sensitive to dogs.<sup>66</sup> A determination of sensitivity to dog was made in 202 children based on a composite score from history, RAST and bronchial or conjunctival allergen challenges. The results with the three common means of expressing results (wheal diameter, wheal diameter compared to the histamine control and titrated prick skin tests) were compared for sensitivity, specificity and overall efficacy. Although the overall efficacy of the histamine reference was greatest in this study, most allergists would prefer to have the maximum sensitivity, which was provided by a wheal ≥3 mm diameter, in order not to miss any truly sensitive patients. Other methods, or clinical judgment, should then be used to distinguish between those who are only sensitized and those who are clinically allergic.<sup>66</sup>

### DEVICES FOR PERCUTANEOUS SKIN TESTING

Intracutaneous skin tests are performed using a hypodermic syringe and needle. Percutaneous tests are performed with an ever-increasing variety of devices.<sup>19,67–72</sup> Some devices have a single stylus with a single or several points and are used either to prick or puncture through a drop of extract or to carry a drop of extract from the extract bottle, so that application of extract and the puncture occur in one step. The puncture technique may be combined with twisting, which generally results in more pain and a greater chance of a false positive test.<sup>73,74</sup> Increasingly, devices are being introduced which have multiple heads, so that up to 10 tests can be accomplished with one

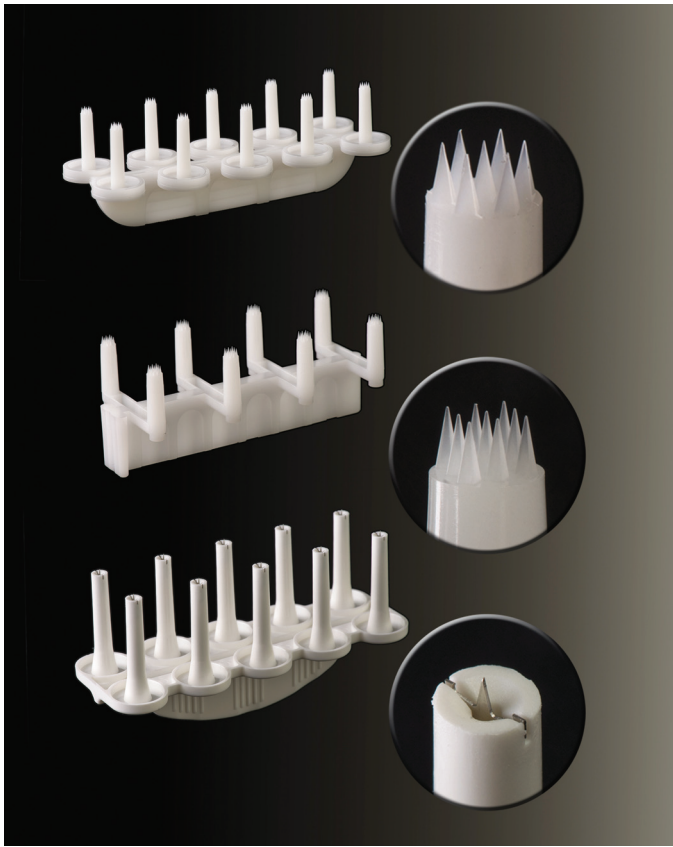

**Figure 19-1** Examples of multi-headed devices for prick/puncture skin testing. From top to bottom: Skintestor OMNI (Greer Laboratories, LeNoir, NC), MultiTest II (Lincoln Diagnostics, Decatur, IL) and ComforTen (HollisterStier Spokane, WA).

application (Figure 19-1). Generally the multiple-headed skin test devices are designed to first be dipped into the extract bottles, then applied to the skin so that testing is accomplished in one step. Both the single and multiple test devices for percutaneous testing vary in the degree of trauma that they impart to the skin, therefore they vary in the size of positive reactions and also in the likelihood of producing a reaction at the site of the negative control. Thus, different devices require different criteria for what is the minimum wheal diameter that constitutes a positive reaction.

Before selecting a device for clinical use, it is prudent to test the device at multiple sites on multiple subjects with histamine to rule out false negative tests and with saline to assess the maximum wheal size resulting from the trauma induced by the device.

### PLACEMENT OF ADJACENT TESTS

There are two reports, both describing intracutaneous testing with hymenoptera venom, which indicate that false positive tests can result from an adjacent positive histamine control.<sup>75,76</sup> The influence of large positive reactions to histamine or to inhalant allergen on adjacent prick skin tests was prospectively studied.<sup>22</sup> There was no evidence of falsely positive prick skin tests attributable to the large adjacent reactions, even when the test sites were only separated by 2 cm. Thus, it appears that the augmentation that has been observed may be limited to

intracutaneous testing, and perhaps also to testing with the active constituents in the hymenoptera venom.

## Special Considerations

### SAFETY OF SKIN TESTING

Deaths have been reported with skin testing.<sup>77,78</sup> For the most part these were reactions to testing with horse serum or other potent allergens and, almost without exception, they were associated with intradermal testing.<sup>77</sup> Severe reactions can occur, however, even with prick skin testing in very sensitive patients treated with undiluted commercial or fresh food extracts.<sup>79</sup> A fatal reaction was reported in a young woman with moderate asthma, probably poorly controlled, following application of 90 food allergens employing the Dermapik (Greer Laboratories, Lenoir, NC) skin testing device.<sup>78</sup> In a private practice, 10400 patients were skin tested first by prick, followed, if negative, by intradermal testing.<sup>80</sup> Two systemic reactions occurred, both with intradermal testing. One was in a patient who had had a negative prick skin test, and the other in a patient who did not have preliminary prick skin testing. The experience with allergy skin testing at the Mayo Clinic between 1992 and 1997 was reviewed.<sup>77</sup> Puncture skin testing was performed in 16505 patients, while 1806 received puncture tests followed by intracutaneous tests for selected allergens (hymenoptera venom, penicillin and other drugs). Five patients experienced systemic reactions following puncture tests, while one patient experienced a systemic reaction to an intracutaneous test following a negative puncture test. Two of the five patients who experienced systemic reactions to puncture testing had positive reactions to latex. One patient reacted to both latex and aeroallergens, while two reacted only to aeroallergens. Thus, for prick/puncture testing to aeroallergens, systemic reactions, none of which were life threatening, occurred with an incidence of about 0.02%. Another university allergy clinic reported an incidence of systemic symptoms with prick skin testing of 0.4%, but none were associated with severe asthma or hypotension.<sup>81</sup>

### LOCAL ALLERGY

Patients sometimes present with what sounds like a convincing clinical history for an allergic respiratory condition, but they have negative skin tests to the suspected allergen and sometimes to all allergens. There are several studies that report that patients may be sensitive to an allergen and have IgE antibodies to that allergen in their nasal secretions, even though prick skin tests and serum in vitro tests for that same allergen are negative. The question of local nasal allergy has been extensively studied by a group from Malaga, Spain. Fifty adult subjects with persistent rhinitis who had negative prick skin tests and no specific IgE for perennial allergens and who had negative intradermal skin tests for house dust mites (PNAR) were compared to 30 subjects with persistent allergic rhinitis (PAR) and 30 nonallergic controls.<sup>82</sup> Subjects with PNAR and PAR did not differ in symptoms or nasal cytology. All of the PAR, 54% of the PNAR and none of the normal controls had a positive nasal challenge with house dust mite allergen *Dermatophagoides pteronyssinus* (DP). Nasal DP-specific IgE was found in 23/30 with PAR and 6/50 with PNAR, all of whom had positive nasal challenges with DP. Subsequently they studied 32 patients with apparent nonallergic spring symptoms. Positive nasal challenges to grass or olive



pollen extracts or both were found in 63%.<sup>83</sup> They also reported an increase in specific IgE in the nasal secretions 24 hours after the positive nasal challenges.<sup>84</sup> A 5-year follow-up of 194 patients with local nasal allergy diagnosed by this group revealed that very few had developed systemic sensitization.<sup>85</sup> In their experience local nasal allergy constituted 25.7% of the rhinitis population and more than 47% of patients previously diagnosed with nonallergic rhinitis.<sup>85</sup>

### DELAYED REACTIONS TO SKIN TESTS

Immediate skin reactions to histamine typically peak at 8 minutes, while those to allergen peak at 15 minutes. Large allergen induced immediate skin tests may be followed by a late cutaneous reaction. Progressive erythema and induration occur at the site of the immediate reaction, peaking at 4 to 6 hours. These reactions can be triggered by mast cell mediators released by a variety of mechanisms including allergens, anti-IgE and nonimmunologic mast cell degranulating agents, but not by histamine alone.<sup>86</sup> There appears to be a threshold size of the immediate reaction below which the late phase reaction does not occur. Beyond that size, there is a rough correlation between the size of the immediate reaction and the size of the resulting late phase reaction in the same individual<sup>86</sup> and in unselected patients.<sup>87</sup> The IgE-mediated late cutaneous reaction has not been described in the absence of the immediate reaction. The late phase cutaneous reaction is not suppressed by antihistamines but is reduced by corticosteroids. Furthermore, it is markedly reduced by allergen immunotherapy, more so than the immediate reactions.<sup>36</sup>

Isolated, delayed reactions to allergy skin testing have been described.<sup>88</sup> Furthermore, when looked for, they appear to fairly commonly follow intracutaneous testing.<sup>88</sup> Two hundred and ninety two adult patients who had received a total of 2700 intracutaneous tests were examined after 20 minutes for immediate reactions and again after 48 hours for evidence of delayed reactions.<sup>88</sup> Immediate reactions were observed in 17% of the skin tests in allergic and 5% of the skin tests in nonallergic patients. At 48 hours, delayed reactions were present at 7% of the skin test sites in the allergic and 5% in the nonallergic patients. Delayed reactions were over twice as common at sites of positive immediate as negative immediate skin reactions. Those occurring at the site of negative immediate skin tests had the histology of a delayed-type hypersensitivity reaction. There was no suggestion that the late or delayed cutaneous reactions had clinical relevance.

### RELATION OF SKIN TESTS TO IN VITRO MEASUREMENTS OF SPECIFIC IgE

For at least some aeroallergens, the in vitro tests are somewhat less sensitive than percutaneous tests,<sup>89</sup> and both are much less sensitive than intracutaneous tests at the concentrations of allergen extracts that are commonly employed. Even though they are less sensitive than the intracutaneous test, the prick/puncture and in vitro tests still are often positive in patients without clinical symptoms. This has led to attempts to increase the diagnostic precision of these tests by defining cut-offs that enhance specificity without too great a loss in sensitivity. An ambitious study recruited 267 patients who were prick skin test positive and had a clear history of respiratory symptoms in relation to the allergen producing the positive skin test.<sup>90</sup> They

were compared to 232 subjects with similar positive prick skin tests but negative histories of respiratory symptoms caused by the aeroallergens producing the positive prick skin tests. Finally, there were 243 nonallergic controls. Patients also had in vitro testing for the allergens that produced the positive prick skin tests. The investigators constructed receiver operating characteristic curves for sensitivity versus specificity for both in vitro and prick skin tests. They found maximum diagnostic accuracy at cut-offs of 11.7 kU/L in the Pharmacia CAP system (where threshold for sensitivity is 0.35 kU/L). The maximum diagnostic accuracy of prick skin testing was a wheal area of 32.2 mm (roughly 6 mm diameter). They also reported that the diagnostic accuracy of in vitro testing exceeded that of the prick skin test.

Despite similar sensitivity and performances by the in vitro and percutaneous tests, the quantitative relationship between them in individuals is relatively weak. Reactivity on intracutaneous skin testing and in vitro testing was measured in 43 patients with rhinitis and/or asthma employing five purified major allergens.<sup>91</sup> The overall correlation for skin testing versus serum IgE was only 0.68. For the same level of specific IgE, the amount of the allergen required in different subjects for a positive prick skin test varied by as much as 100-fold. Skin reactivity was adversely affected by total IgE and correlated positively with reactivity of the skin to histamine. Skin testing correlated better than in vitro testing with histamine release, suggesting that 'releasability' as well as differences in reactivity of the skin to released mediators might account for part of the residual variation in the correlation between skin test results and levels of IgE antibodies.

An additional factor may be the affinity for IgE-allergen binding.<sup>92</sup> Reactions on prick skin testing to ragweed and *Dermatophagoides pteronyssinus* were compared to serum Amb a 1- and Der p 1-specific IgE levels in 165 members from families with histories of clinical atopy. Those donors with positive skin test reactions tended to have higher concentrations of specific IgE than those donors with negative skin tests. However, there was considerable overlap between the skin test positive and skin test negative groups, without a clear demarcation between them, and mean values between prick skin test positive and prick skin test negative groups were not statistically significant. Donors with positive skin test reactions had, on average, higher binding affinities than those with negative skin test results. These values differed significantly for the two groups ( $P < .001$ ). The product of affinity and concentration, termed the antibody capacity, provided a much clearer demarcation between donors who were skin test positive and those who were skin test negative.

### RELATION OF SKIN TESTS TO NASAL ALLERGEN CHALLENGE AND IN VITRO ASSESSMENT OF SPECIFIC IgE

Nasal allergen challenges with 3-fold increasing numbers of grass pollen grains, prick skin tests with 3-fold increasing concentrations of grass pollen extract and in vitro tests utilizing the same grass pollen extract were compared in 44 subjects with rhinitis and 10 nonallergic controls during the grass pollen season.<sup>1</sup> The nasal challenge method, which employs a total symptom score of 5 as an end-point, has been validated by demonstration of release of PGD<sub>2</sub> into nasal secretion at end-point and by correlation of threshold scores with symptoms on



seasonal exposure to grass pollen. Nasal challenges were positive in 41 of 43 patients and 0 of 10 controls. There was a significant correlation ( $R_s = .54$ ,  $P < .005$ ) between threshold for nasal challenge and threshold for prick skin testing. There was no significant correlation between nasal threshold and levels of specific IgE, suggesting that releasability of mast cells and basophils and reactivity to the released mediators may be an important parameter in determining symptoms. In a related study, the correlation between threshold for nasal allergen challenge and titrated prick skin test was confirmed and both were shown to correlate with symptoms during natural pollen exposure.<sup>93</sup>

## RELATION OF SKIN TESTS TO BRONCHIAL ALLERGEN CHALLENGE

There is a relatively poor correlation between the results of allergen skin testing and bronchial allergen challenge. The reason is the presence of a second variable, nonspecific bronchial hyperresponsiveness as measured by histamine or methacholine inhalation challenge. It was observed that positive bronchial allergen challenges occurred almost exclusively in subjects with positive prick skin tests,<sup>94</sup> but that the correlation between skin testing and bronchial allergen challenge could be improved considerably by incorporating the threshold of nonspecific bronchial responsiveness.<sup>95,96</sup> A prospective study confirmed these retrospective observations.<sup>2</sup> The early bronchoconstrictor response to allergen challenge could be predicted within an 8-fold range by a formula employing skin test reactivity and bronchial sensitivity to histamine. It was pointed out that this degree of prediction was better than the reproducibility of bronchial allergen challenge achieved by some investigators (Box 19-1).

### BOX 19-1 KEY CONCEPTS

- Skin testing with allergenic extracts is the favored method of in vivo testing for IgE-mediated sensitivity.
- The preferred method of skin testing is percutaneous (prick or puncture), with intracutaneous (intradermal) testing generally reserved for weak allergenic extracts such as hymenoptera venom or agents used for testing for drug allergy.
- Advantages of percutaneous (prick or puncture) testing over intracutaneous (intradermal) include: (1) they are safer, less technically demanding, less painful, more rapidly performed, and many tests can be performed in one session; (2) the extracts are more stable and positive and negative reactions are more easily differentiated; most importantly, (3) positive reactions correlate better with clinical sensitivity than is the case with intracutaneous tests.
- Advantages of the intracutaneous tests are a somewhat better reproducibility and greater sensitivity. The latter, however, has not been found to be useful for detecting clinically relevant sensitivity in several studies.
- The results of skin testing correlate only weakly with those from in vitro studies with the same allergen in the same patient. The size of the skin test reactions depends, in addition to the amount of specific IgE, on the binding affinity of the IgE antibody, the releasability of the patient's mast cells, and the reactivity of their skin to released mediators.
- In a particular individual, the size of the skin test will also depend on the area of the body used for testing, with the back being more reactive than the arm.
- Devices for percutaneous skin testing vary greatly in the size of reaction and the likelihood of a false positive reaction. Thus different threshold values for a positive reaction must be used with different devices.

 The complete reference list can be found on the companion Expert Consult website at <http://www.expertconsult.inkling.com>.

## KEY REFERENCES

- Barbee RA, Brown WG, Kaltenborn W, Halonen M. Allergen skin-test reactivity in a community population sample: correlation with age, histamine skin reactions, and total serum immunoglobulin E. *J Allergy Clin Immunol* 1981;68:15–19.
- Meiser JP, Nelson HS. Comparing conventional and acetone-precipitated dog allergen extract skin testing. *J Allergy Clin Immunol* 2001;107:744–5.
- Esch RE. Manufacturing and standardizing fungal allergen products. *J Allergy Clin Immunol* 2004;113:210–15.
- Rosen JP, Selcow JE, Mendelson ML, Grodovsky MP, Factor JM, Sampson HA. Skin testing with natural foods in patients suspected of having food allergies: is it a necessity? *J Allergy Clin Immunol* 1994;93:1068–70.
- Sears MR, Herbison GP, Holdaway MD, Hewitt CJ, Flannery EM, Silva PA. The relative risks of sensitivity to grass pollen, house dust mite and cat dander in the development of childhood asthma. *Clin Exp Allergy* 1989;19:419–24.
- Hagy GW, Settupane GA. Prognosis of positive allergy skin tests in an asymptomatic population: a three year follow-up of college students. *J Allergy* 1971;48:200–11.
- Nelson HS, Oppenheimer JJ, Buchmeier A, Kordash TR, Freshwater LL. An assessment of the role of intradermal skin testing in the diagnosis of clinically relevant allergy to timothy grass. *J Allergy Clin Immunol* 1996;97:1193–201.
- Wood RA, Phipatanakul W, Hamilton RG, Eggleston PA. A comparison of skin prick tests, intradermal skin tests, and RASTs in the diagnosis of cat allergy. *J Allergy Clin Immunol* 1999;103:773–9.
- Konstantinou GN, Bousquet P-J, Zuberbier T, Papadopoulos N. The longest wheal diameter is the optimal measurement for the evaluation of skin prick tests. *Int Arch Allergy Immunol* 2010;151:343–5.
- Rondon C, Campo P, Zambonino MA, Blanca-Lopez N, Torres MJ, Melendez L, et al. Follow-up study in local allergic rhinitis shows a consistent entity not evolving to systemic allergic rhinitis. *J Allergy Clin Immunol* 2014;133:1026–31.

## REFERENCES

- Bousquet J, Lebel B, Dhlvert H, Bataille Y, Martinot B, Michel FB. Nasal challenge with pollen grains, skin-prick tests and specific IgE in patients with grass pollen allergy. *Clin Allergy* 1987;17:529–36.
- Cockcroft DW, Murdock KY, Kirby J, Hargreave F. Prediction of airway responsiveness to histamine. *Am Rev Respir Dis* 1987;135:264–7.
- Bernstein IL, Li JT, Bernstein DI, Hamilton R, Spector S, Tan R, et al. Allergy diagnostic testing: an updated practice parameter. *Ann Allergy Asthma Immunol* 2008;100(3 Suppl. 3): S1–148.
- Hendrick DJ, Davies RJ, D'Souza MF, Pepys J. An analysis of skin prick test reactions in 656 asthmatic patients. *Thorax* 1975;30:2–8.
- Viner AS, Jackman N. Retrospective study of 1271 patients diagnosed as perennial rhinitis. *Clin Allergy* 1976;6:251–9.
- Rajka G, Prurigo Besnier (atopic dermatitis) with special reference to the role of allergy factors. II. The evaluation of the results of skin reactions. *Acta Derm Venereol* 1961;41:1–39.
- Arbes SJ Jr, Gergen PJ, Elliott L, Zeldin DC. Prevalences of positive skin test responses to 10 common allergens in the US population: results from the Third National Health and Nutrition Examination Survey. *J Allergy Clin Immunol* 2005;116:377–83.
- Adinoff AD, Rosloniec DM, McCall LL, Nelson HS. Immediate skin test reactivity to Food and Drug Administration-approved standardized extracts. *J Allergy Clin Immunol* 1990;86: 766–74.
- Barbee RA, Lebowitz MD, Thompson HC, Burrows B. Immediate skin test reactivity in a general population sample. *Ann Intern Med* 1976;84:129–33.
- Barbee RA, Brown WG, Kaltenborn W, Halonen M. Allergen skin-test reactivity in a community population sample: correlation with age, histamine skin reactions, and total serum immunoglobulin E. *J Allergy Clin Immunol* 1981;68: 15–19.
- Roberts G, Zhang H, Karamus W, Raza A, Scott M, Matthews S, et al. Trends in cutaneous sensitization in the first 18 years of life: results from the 1989 Isle of Wight birth cohort study. *Clin Exp Allergy* 2012;42:1501–9.
- Warm K, Backman H, Lindberg A, Lundback B, Ronmark E. Low incidence and high remission of allergic sensitization among adults. *J Allergy Clin Immunol* 2012;129:136–42.
- Hanneuse Y, Delespesse G, Hudson D, de Halleux F, Jacques JM. Influence of ageing on IgE-mediated reactions in allergic patients. *Clin Allergy* 1978;8:165–74.
- Skassa-Brociek W, Manderscheid J-C, Michel F-B, Bousquet J. Skin test reactivity to histamine from infancy to old age. *J Allergy Clin Immunol* 1987;80:711–16.
- Menardo JL, Bousquet J, Rodiere M, Astrue J, Michel FB. Skin test reactivity in infancy. *J Allergy Clin Immunol* 1985;75:646–51.
- Stuckey MS, Witt CS, Schmitt LH, Warlow R, Lattimore M, Dawkins RL. Histamine sensitivity influences reactivity to allergens. *J Allergy Clin Immunol* 1985;75:373–6.
- Vichyanond P, Nelson HS. Circadian variation of skin reactivity and allergy skin tests. *J Allergy Clin Immunol* 1989;83:1101–6.
- Oppenheimer JJ, Nelson HS. Seasonal variation in immediate skin test reactions. *Ann Allergy* 1993;71:227–9.
- Kalogeromitos D, Katsarou A, Armenaka M, Ryopoulos D, Zapanti M, Stratigos I. Influence of the menstrual cycle on skin-prick test reactions to histamine, morphine and allergen. *Clin Exp Allergy* 1995;25:461–6.
- Wise SL, Meador KJ, Thompson WO, Avery SS, Loring DW, Wray BB. Cerebral lateralization and histamine skin test asymmetries in humans. *Ann Allergy* 1993;70:328–32.
- Nelson HS, Rosloniec DM, McCall LL, Ikle D. Comparative performance of five commercial skin test devices. *J Allergy Clin Immunol* 1993; 92:750–6.
- Nelson HS, Knoetzer J, Bucher B. Effect of distance between sites and region of the body on results of skin prick tests. *J Allergy Clin Immunol* 1996;97:596–601.
- Skoner DP, Gentile DA, Angelini B, Doyle WJ. Allergy skin test responses during experimental infection with respiratory syncytial virus. *Ann Allergy Asthma Immunol* 2006;96: 834–9.
- Cook TJ, MacQueen DM, Wittig HJ, Thomby JJ, Lantes RL, Cirtue CM. Degree and duration of skin test suppression and side effects with antihistamines. *J Allergy Clin Immunol* 1973;51: 71–7.
- Meltzer EO, Gillman SA. Efficacy of fexofenadine versus desloratadine in suppressing histamine-induced wheal and flare. *Allergy Asthma Proc* 2007;28:67–73.
- Rao KS, Menon PK, Hillman BC, Sebastian CS, Bairnfather L. Duration of the suppressive effect of tricyclic antidepressants on histamine-induced wheal-and-flare reactions in human skin. *J Allergy Clin Immunol* 1988;82:752–7.
- Miller J, Nelson HS. Suppression of immediate skin tests by ranitidine. *J Allergy Clin Immunol* 1989;84:895–9.
- Kupczyk M, Kuprys I, Gorski P, Kuna P. The effect of montelukast (10 mg daily) and loratadine (10 mg daily) on wheal, flare and itching reactions in skin prick tests. *Pulm Pharmacol Ther* 2006;20:85–9.
- While M, Rothrock S, Meeves S, Liao Y, Georges G. Comparative effects of fexofenadine and montelukast on allergen-induced wheal and flare. *Allergy Asthma Proc* 2005;26:221–8.
- Pipkorn U, Hammarlund A, Enerback L. Prolonged treatment with topical glucocorticoids results in an inhibition of the allergen-induced wheal-and-flare response and a reduction in skin mast cell numbers and histamine content. *Clin Exp Allergy* 1989;19:19–25.
- Slott RI, Zweiman B. A controlled study of the effect of corticosteroids on immediate skin test reactivity. *J Allergy Clin Immunol* 1974;554: 229–34.
- Olson R, Karpink MH, Shelanski S, Atkins PC, Zweiman B. Skin reactivity to codeine and histamine during prolonged corticosteroid therapy. *J Allergy Clin Immunol* 1990;86:153–9.
- Des Roches A, Paradis L, Bougeard Y-H, Godard P, Bousquet J, Chanez P. Long-term oral corticosteroid therapy does not alter the results of immediate allergy skin prick tests. *J Allergy Clin Immunol* 1996;98:522–7.
- Corren J, Shapiro G, Reimann J, Denez Y, Wong D, Adelman D, et al. Allergen skin tests and free IgE levels during reduction and cessation of omalizumab therapy. *J Allergy Clin Immunol* 2008;121:506–11.
- Dantzer BS, Tipton WR, Nelson HS, O'Barr TP. Tissue threshold changes during the first months of immunotherapy. *Ann Allergy* 1980; 45:213–16.
- Nish WA, Charlesworth EN, Davis TL, Whisman BA, Valtier S, Charlesworth MG, et al. The effect of immunotherapy on the cutaneous late phase reaction to allergen. *J Allergy Clin Immunol* 1994;93:484–93.
- Dreborg S, Holgersson M, Nilsson G, Zetterstrom O. The dose response relationship of allergen, histamine, and histamine releasers in skin prick test and the precision of the skin prick test method. *Allergy* 1987;42:117–25.
- Harris RI, Stern MA, Watson HK. Dose response curve of allergen and histamine in skin prick tests. *Allergy* 1989;43:565–72.
- Meiser JP, Nelson HS. Comparing conventional and acetone-precipitated dog allergen extract skin testing. *J Allergy Clin Immunol* 2001; 107:744–5.
- Esch RE. Manufacturing and standardizing fungal allergen products. *J Allergy Clin Immunol* 2004;113:210–15.
- Patterson ML, Slater JE. Characterization and comparison of commercially available German and American cockroach allergen extracts. *Clin Exp Allergy* 2002;32:721–7.
- Esch RG. Role of proteases on the stability of allergic extracts. In: Klein R, editor. Regulatory control and standardization of allergic extracts. Stuttgart: Gustav Fischer Verlag; 1990. p. 171–7.
- Dreborg S, Foucard T. Prick-prick skin test with fresh foods. *Allergy* 1983;38:167–71.
- Rosen JP, Selcow JE, Mendelson ML, Grodovsky MP, Factor JM, Sampson HA. Skin testing with natural foods in patients suspected of having food allergies: is it a necessity? *J Allergy Clin Immunol* 1994;93:1068–70.
- Ortolani C, Ispano M, Pastorello EA, Ansaloni R, Magri GC. Comparison of results of skin prick tests (with fresh foods and commercial food extracts) and RAST in 100 patients with oral allergy syndrome. *J Allergy Clin Immunol* 1989;83:683–90.
- Ancona GR, Schumacher IC. The use of raw foods as skin testing material in allergic disorders. *Calif Med* 1950;73:473–5.
- Bock SA, Lee W-Y, Remigio L, Helst A, May CD. An appraisal of skin tests with food extracts for diagnosis of food hypersensitivity. *Clin Allergy* 1978;8:559–64.
- Indrajana T, Spiekma FT, Voorhorst R. Comparative study of the intracutaneous, scratch and prick tests in allergy. *Ann Allergy* 1971;29: 639–50.
- Vanselow NA. Skin testing and other diagnostic procedures. In: Sheldon JM, Lovell RG, Mathews KP, editors. A manual of clinical allergy. 2nd ed. Philadelphia: WB Saunders Company; 1967 [Chapter 4].
- Sears MR, Herbison GP, Holdaway MD, Hewitt CJ, Flannery EM, Silva PA. The relative risks of sensitivity to grass pollen, house dust mite and cat dander in the development of childhood asthma. *Clin Exp Allergy* 1989;19:419–24.
- Henderson FW, Stewart PW, Burchinal MR, Voter KZ, Strobe GL, Ivins SS, et al. Respiratory allergy and the relationship between early childhood lower respiratory illness and subsequent lung function. *Am Rev Respir Dis* 1992;145: 283–90.
- Gergen PJ, Turkeltaub PC. The association of individual allergen reactivity with respiratory disease in a national sample: data from the

- second National Health and Nutrition Examination Survey, 1976–80 (NHANNES II). *J Allergy Clin Immunol* 1992;90:579–88.
53. Hagy GW, Settupane GA. Prognosis of positive allergy skin tests in an asymptomatic population: a three year follow-up of college students. *J Allergy* 1971;48:200–11.
  54. Hagy GW, Settupane GA. Risk factors for developing asthma and allergic rhinitis: a 7-year follow-up of college students. *J Allergy Clin Immunol* 1976;58:330–6.
  55. Brown WG, Hhalonen MJ, Kaltenborn WT, Barbee RA. The relationship of respiratory allergy, skin test reactivity, and serum IgE in a community population sample. *J Allergy Clin Immunol* 1979;63:328–35.
  56. Nelson HS, Oppenheimer JJ, Buchmeier A, Kordash TR, Freshwater LL. An assessment of the role of intradermal skin testing in the diagnosis of clinically relevant allergy to timothy grass. *J Allergy Clin Immunol* 1996;97:1193–201.
  57. Wood RA, Phipatanakul W, Hamilton RG, Eggleston PA. A comparison of skin prick tests, intradermal skin tests, and RASTs in the diagnosis of cat allergy. *J Allergy Clin Immunol* 1999;103:773–9.
  58. Sharma HP, Wood RA, Bravo AR, Matsui EC. A comparison of skin prick tests, intradermal skin tests, and specific IgE in the diagnosis of mouse allergy. *J Allergy Clin Immunol* 2008;121:933–9.
  59. Oppenheimer J, Nelson HS. Skin testing: a survey of allergists. *Ann Allergy Asthma Immunol* 2006;96:19–23.
  60. Ownby DR. Computerized measurement of allergen-induced skin reactions. *J Allergy Clin Immunol* 1982;69:536–8.
  61. Konstantinou GN, Bousquet P-J, Zuberbier T, Papadopoulos N. The longest wheal diameter is the optimal measurement for the evaluation of skin prick tests. *Int Arch Allergy Immunol* 2010;151:343–5.
  62. Haahtela T, Burbach GJ, Bachert C, Bindsvle-Jensen C, Bonini S, Boousquet J, et al. Clinical relevance is associated with allergen specific wheal size in skin prick testing. *Clin Exp Allergy* 2014;44:407–16.
  63. Scandinavian Society of Allergy. Standardization of diagnostic work in allergy. *Acta Allergologica* 1974;29:239–40.
  64. Taudorf E, Malling H-J, Laursen LC, Lanner A, Weeke B. Reproducibility of histamine skin prick test. *Allergy* 1985;40:344–9.
  65. Dreborg S. Skin testing: the safety of skin tests and information obtained from using different methods and concentrations of allergens. *Allergy* 1993;48:473–8.
  66. Vanto T. Efficacy of different skin prick testing methods in the diagnosis of allergy to dog. *Ann Allergy* 1983;50:340–3.
  67. Nelson HS, Lahr J, Buchmeier BA, McCormick D. Evaluation of devices for prick skin testing. *J Allergy Clin Immunol* 1998;101:153–6.
  68. Nelson HS, Kolehmainen C, Lahr J, Murphy J, Buchmeier A. A comparison of multiheaded devices for allergy skin testing. *J Allergy Clin Immunol* 2004;113:1218–19.
  69. Carr WW, Martin B, Howard RS, Cox L, Borish L. Comparison of test devices for skin prick testing. *J Allergy Clin Immunol* 2005;116:341–6.
  70. Yoon I-K, Martin BL, Carr WW. A comparison of two single-headed and two multi-headed allergen skin test devices. *Allergy Asthma Proc* 2006;27:473–8.
  71. Nelson HS, Lopez P, Curran-Everett D. Evaluation of a skin test device designed to be less painful. *J Allergy Clin Immunol* 2012;130:1422–3.
  72. Nelson HS, Lopez P, Curran-Everett D. Pain-perception and performance of 3 devices for single-site allergen skin testing. *Allergy Asthma Proc* 2014;35:63–5.
  73. Corder WT, Wilson NW. Comparison of three methods of using the DermaPIK with the standard method of epicutaneous skin testing. *Ann Allergy Asthma Immunol* 1995;75:434–8.
  74. Sangsupawanich P, Chamnanphol S, Koonrungrisomboon D. Evaluation of three methods for using the Duotip-Test device for skin testing. *Asian Pac J Allergy Immunol* 2000;18:153–6.
  75. Tipton WR. Influence of histamine controls on skin tests with hymenoptera venom. *Ann Allergy* 1980;44:204–5.
  76. Koller DY, Pirker C, Jarisch R, Gotz M. Influence of the histamine control on skin reactivity in skin testing. *Allergy* 1992;47:58–9.
  77. Valyasevi MA, Maddox DE, Li JTC. Systemic reactions to allergy skin tests. *Ann Allergy* 1999;83:132–6.
  78. Bernstein DI, Wanner M, Boorish L, Liss GM. Twelve-year survey of fatal reactions to allergen injections and skin testing: 1990–2001. *J Allergy Clin Immunol* 2004;113:1129–36.
  79. Novembre E, Bernardini R, Bertini G, Massal G, Vierucci A. Skin-prick-test-induced anaphylaxis. *Allergy* 1995;50:511–13.
  80. Lin MS, Tanner E, Lynn J, Friday GA Jr. Non-fatal systemic allergic reactions induced by skin testing and immunotherapy. *Ann Allergy* 1993;71:557–62.
  81. Bagg A, Chacko T, Lockey R. Reactions to prick and intradermal skin tests. *Ann Allergy Asthma Immunol* 2009;102:400–2.
  82. Rondon C, Romero JJ, Lopez S, Antunez C, Martin-Casanez E, Torres MJ, et al. Local IgE production and positive nasal provocation test in patients with persistent nonallergic rhinitis. *J Allergy Clin Immunol* 2007;119:899–905.
  83. Rondon C, Dona I, Lopez S, Campo P, Romero JJ, Torres MJ, et al. Seasonal idiopathic rhinitis with local inflammatory response and specific IgE in absence of systemic response. *Allergy* 2008;63:1352–8.
  84. Rondon C, Fernandez J, Lopez S, Campo P, Dona I, Torres MJ, et al. Nasal inflammatory mediators and specific IgE production after nasal challenge with grass pollen in local allergic rhinitis. *J Allergy Clin Immunol* 2009;124:1005–211.
  85. Rondon C, Campo P, Zambonino MA, Blanca-Lopez N, Torres MJ, Melendez L, et al. Follow-up study in local allergic rhinitis shows a consistent entity not evolving to systemic allergic rhinitis. *J Allergy Clin Immunol* 2014;133:1026–31.
  86. DeShazo RD, Levinson AI, Dvorak HF, Davis RW. The late phase skin reaction: evidence for activation of the coagulation system in an IgE-dependent reaction in man. *J Immunol* 1979;122:692–8.
  87. Agarwal K, Zetterstrom O. Diagnostic significance of late cutaneous allergic responses and their correlation with radioallergosorbent test. *Clin Allergy* 1982;12:489–97.
  88. Green GR, Zweiman B, Beerman H, Hildreth EA. Delayed skin reactions to inhalant antigens. *J Allergy* 1967;40:224–36.
  89. Nolte H, DuBuske LM. Performance characteristics of a new automated enzyme immunoassay for the measurement of allergen-specific IgE. *Ann Allergy Asthma Immunol* 1997;79:27–34.
  90. Pastorello EA, Incorvaia C, Ortolani C, Bonini S, Canonica GW, Romagnani S, et al. Studies on the relationship between the level of specific IgE antibodies and the clinical expression of allergy. I. Definition of levels distinguishing patients with symptomatic from patients with asymptomatic allergy to common aeroallergens. *J Allergy Clin Immunol* 1995;96:580–7.
  91. Witteman AM, Stapel SSO, Perdok GJ, Sjamsoedin DH, Jansen HH, Aalberse RC, et al. The relationship between RAST and skin test results in patients with asthma or rhinitis: a quantitative study with purified major allergens. *J Allergy Clin Immunol* 1996;97:16–25.
  92. Pierson-Mullany LK, Jackola DR, Blumenthal MN, Rosenberg A. Evidence of an affinity threshold for IgE-allergen binding in the percutaneous skin test reaction. *Clin Exp Allergy* 2002;32:107–16.
  93. Bousquet J, Maasch H, Martinot B, Hejjauoui A, Wahl R, Michel FB. Double-blind, placebo-controlled immunotherapy with mixed grass-pollen allergoids. II. Comparison between parameters assessing the efficacy of immunotherapy. *J Allergy Clin Immunol* 1988;82:439–46.
  94. Bryant DH, Burns MW, Lazarus L. The correlation between skin tests, bronchial provocation tests and the serum level of IgE specific for common allergens in patients with asthma. *Clin Allergy* 1975;5:145–57.
  95. Killian D, Cockcroft DW, Hargreave FE, Dolovich J. Factors in allergen-induced asthma: relevance of the intensity of the airways allergen reaction and nonspecific bronchial reactivity. *Clin Allergy* 1976;6:219–25.
  96. Bryant DH, Burns WM. Bronchial histamine reactivity: its relationship to the reactivity of the bronchi to allergens. *Clin Allergy* 1976;6:523–32.

# Outdoor Allergens

RICHARD W. WEBER

## KEY POINTS

- Sources of airborne allergens vary from microscopic to large fauna.
- Outdoor aeroallergenic particles include intact pollen grains or spores, as well as cell fragments and submicronic particles.
- Preferred samplers measure a calculable volume of air to determine the density of aeroallergens and have capture efficacy of particles down to 3–5 micron.
- Meteorological parameters of temperature and precipitation have the greatest impact on timing and intensity of airborne pollen concentration.
- Increased atmospheric temperature and CO<sub>2</sub> concentration act to increase allergenic plant biomass and pollen production.

Aerobiology is the science of airborne emanations of organic or biologic origin. Aeroallergens may be dispersed on a variety of particle sizes and come from various sources and settings (see [Table 20-1](#)).<sup>1</sup> The origin may be: microscopic such as bacteria or protozoa; at the limits of visual detection such as dust mites; or easily seen such as mushrooms, bracket fungi or animals such as cats, dogs or horses. The airborne particle may be: a cell, intact pollen grain or cytoplasmic component thereof; fungal spore or mycelial fragment; or protein adhering to epidermal scales or dust particles, or dissolved in water droplets. Outdoor sources are frequently of plant origin, while animal allergens are greater problems indoors; fungal spores may be troublesome both indoors and outdoors. Once entrained into airstreams, aeroallergens may be deposited on conjunctival or nasal membranes, or inhaled into the lungs.

## General Principles of Allergen Aerobiology

### POLLEN

Vascular plants propagate through extension, trunk or root shoots, rhizomes or stolons, or by seed. Sexual reproduction is accomplished by transport of the male gamete, the pollen or spore, to the female gamete, the ovary. Pollen dispersal mechanisms are via the wind, anemophily or with a vector such as an insect, entomophily. Insect pollinated plants are less frequently inducers of hay fever. Some amphiphilous plants utilize both mechanisms.

### FUNGI

Fungi comprise one of the seven kingdoms of living organisms, more closely related to the animal kingdom than to the plant kingdom. Fungi are eukaryotic organisms with chromosomes within membrane-bound nuclei, dividing through mitosis. Fungi have chitin-containing cell walls, a polysaccharide found also in insect exoskeletons. Fungi may be unicellular, syncytial (many nuclei not separated into different cells) and multicellular (nuclei separated by septa). Complex life cycles have multiple life stages, with both sexual and asexual reproduction. ‘Holomorph’ refers to the fungus throughout its entire life cycle, with ‘anamorph’ referring to the asexual reproductive stage and ‘teleomorph’ to the sexual reproductive stage. Sometimes the alternate life stage is not known, with only the anamorph or the teleomorph identified. Anamorphs without a known teleomorph stage are frequently classified as Deuteromycota, or Fungi Imperfecta: an artificial taxon, a paraphyletic group united only by asexual propagation.<sup>2</sup>

### ANIMALS

While primarily indoors, animal sources may be significant outdoor allergens as well. Heavy hatches of caddis flies or mayflies, or miller moth infestations have been reported to induce allergic symptoms.<sup>3</sup> Occupational exposures to tussock moths in pine trees may bother lumberjacks, and sewer flies municipal sanitation workers.<sup>4</sup> Outdoor horse dander allergen can be sampled down wind of stables.<sup>5</sup>

### SUBMICRONIC ALLERGENIC PARTICLES

The finding that ragweed hay fever symptoms may persist after intact pollen is no longer seen spurred studies demonstrating airborne allergens in submicronic particles.<sup>6,7</sup> Airborne birch antigenic activity has been demonstrated in particles smaller than 2.4 micron. Cytoplasmic starch granules are prominent in grass (Poaceae) and dock (*Rumex*, Polygonaceae) pollen.<sup>8</sup> Grass starch granules have heavy concentrations of groups 1, 5 and 13 allergens.<sup>9–11</sup> While the force of storm-driven raindrops may disrupt grass pollen grains, releasing large amounts of respirable allergen-laden starch granules, Schäppi and colleagues demonstrated that a moisture-drying cycle will result in starch granules emanating through the grass pollen aperture.<sup>9,12</sup>

### CHARACTERISTICS OF WIND-POLLINATED PLANTS

Although wind pollination may appear to be a simpler process than vector-facilitated pollination, it is the later evolutionary mechanism.<sup>13</sup> Its characteristics are summarized in [Box 20-1](#). Anemophilous plants have incomplete flowers, with separate



**TABLE 20-1** Aeroallergen Sources and Types

Allergen Source	Particle Type
Bacteria	Cells, fragments, metabolites
Thermophilic actinomycetes	Spores, metabolites
Algae	Cells, fragments, metabolites
Protozoa	Metabolites
Fungi	Spores, mycelial fragments, metabolites
Ferns and mosses	Spores
Grasses, weeds and trees	Pollens, cytoplasmic particles
Arthropods	Feces, saliva, body parts
Birds	Feces, serum proteins, epidermal debris
Mammals	Dander, saliva, urine

\*Modified from Burge.<sup>1</sup>**BOX 20-1 CHARACTERISTICS OF WIND-POLLINATED PLANTS**

- Incomplete flowers (spatially separate male and female)
- Male flowers exposed to wind
- Petals and sepals insignificant or absent
- Absent attractants (color, aroma, nectar)
- Pollen grains small and dry, reduced ornamentation

**BOX 20-2 THOMMEN'S POSTULATES**

- Pollen must contain excitant of hay fever
- Pollen must be anemophilous
- Pollen must be produced in sufficiently large amounts
- Pollen must be buoyant to carry long distances
- Plant must be widely and abundantly distributed

\*From Thommen.<sup>15</sup>

male and female structures. The male pollen-producing flowers are exposed to the wind. On trees, dangling structures called catkins have hundreds of small individual flowers. On weeds or grasses the inflorescences are thrust up into the air from the higher portions of the plant. Female flowers are lower, at the axils of leaves or at stem junctions. Attractants such as color of petals and sepals, fragrance, or nectar are absent. The pollen grains tend to be small and dry, with reduced ornamentation to minimize turbulence, and with little sticky resin (pollenkitt).

Wind-pollinated trees produce extraordinary amounts of pollen. Erdtman reported a single birch catkin produced about 6 million pollen grains, and an alder catkin 4.5 million. An English oak catkin released 1.25 million grains.<sup>14</sup> By tabulating the number of catkins on such trees, Erdtman calculated the pollen produced in a single year. A birch tree released over 5.5 billion grains over a single year, an alder 7.2 billion and an oak 0.6 billion. Spruce, like birch, produced about 5.5 billion grains in a year. Cereal rye grass produced 4.25 million pollen grains per inflorescence.<sup>14</sup>

Eighty years ago, August Thommen set out five principles necessary for a plant to be an important inducer of pollinosis (Box 20-2). Thommen's Postulates have remained correct, with some caveats.<sup>15</sup> That the pollen must contain an excitant of hay fever is self-evident, and such are proteins or glycoproteins that are easily elutable or coat the surface of expelled

respirable cytoplasmic particles. While the majority of pollinosis inducers are wind pollinated, some primarily insect-pollinated plants will release sufficient airborne pollen to cause sensitization in the proper setting. A single point source could lead to sensitization, such as a tree or shrub situated at a bedroom window. Although most pollen grains come to rest within meters of their source, grains may be transported for hundreds of miles.<sup>14</sup>

**FLORISTIC ZONES**

The distribution of individual plant species is dependent on a multitude of factors. Foremost is 'climate': average high and low temperatures, ambient humidity and average precipitation. Soil factors such as mineral content, pH, and density also impact on plant adaptation and selection.<sup>16</sup> Certain plants are cosmopolitan, adapting to diverse circumstances; others are limited to a niche, adapting to extremes of moisture or temperature. The range of native indigenous species may be limited by niche selectivity. The extent an introduced plant will spread is determined by its adaptability, its aggressiveness and the length of time from introduction. Which plants may be found in different locations may be deduced from several sources. Numerous gardening texts contain 'hardiness zone' maps defined by the United States Department of Agriculture (USDA). There are ten climatic zones in the North American continent based on the average annual minimum temperature: beginning with zone 1 at  $-50^{\circ}\text{F}$ , and progressing by about  $10^{\circ}$  increments to zone 10 at  $30-40^{\circ}\text{F}$ . These isotherms generally define the northern limits of species, determined by ability to survive the winter cold. Exceptions may occur in protected sites with extraneous sources of heat. The USDA maps also consider other factors like rainfall or maximum temperature. A more exact 24-climate zone classification system has been described for the western half of the USA, determined by the interplay of six factors: latitude, elevation, Pacific Ocean influence, continental air mass influence, mountains and hills, and local terrain.<sup>17</sup> However, 24 zones are cumbersome to consider. Solomon popularized ten floristic zones which are a cross between the USDA hardiness zones and additional factors, and offer a useful compromise.<sup>18,19</sup> While the zone boundaries are purposely ill-defined, they are descriptive of the territories they encompass. The zones are: Northern Forest, Eastern Agricultural, Southeastern Coastal Plain, Florida Subtropical, Central Plains, Rocky Mountain, Arid Southwest, Great Basin, Northwest Coastal, and California Lowland. A useful reference giving the distribution maps of many native allergenic plants is *Airborne and Allergenic Pollen of North America*.<sup>20</sup> However, numbers of introduced major allergenic plants do not have distribution maps.

**CHARACTERIZED ALLERGENS**

Numerous allergens have now been characterized, and a list of those that have been fully sequenced is maintained and updated on-line by the International Union of Immunological Societies (IUIS).<sup>21</sup> Allergen nomenclature, by convention, is the first three letters of the genus and the first letter of the species, followed by a number; e.g. the major allergen of short ragweed is Amb a 1, initially known as Antigen E. The number may signify importance or chronology of discovery. Allergens may be renumbered to conform to the function and number of a related allergen. Variations in the molecular weight or charge of an allergen due

to amino acid substitutions or glycosylation are called isoallergens and are designated by a decimal point followed by four digits (e.g. Phl p 5.0102 and Phl p 5.0201).

## AEROALLERGEN SAMPLING

In order to assess the type and intensity of the aeroallergen exposure, it is necessary to monitor the environment. Table 20-2 lists the types of samplers that are useful in assessing outdoor and indoor air. The earliest samplers relied on gravity. The Durham sampler is a greased microscope slide mounted horizontally on a stand, with a roof or rain shield above. Petrie dishes containing the appropriate agar medium have been used indoors for mold studies, with the advantage that the growth medium allows identification of viable spores from the distinctive colony characteristics. Disadvantages of gravimetric samplers are that they can only be quantified in terms of surface area (cm<sup>2</sup>) and do not give an estimate of particle burden in a volume of air. Capture is skewed to larger particles, with smaller mold spores underrepresented as air currents may carry them over the top of the surface. Gravimetric samplers are no longer considered adequate for meaningful study.

Volumetric devices sample volumes of air over a given time interval and report in particles/m<sup>3</sup>/24 hours (Table 20-2). The Rotorod seen in Figure 20-1A is a rotary impaction device that spins two small plastic rods at fixed time intervals, usually for 1 minute in every 10 (total of 144 minutes in 24 hours). The rods are lowered into the ambient air from the spinning armature by centrifugal force. The silicone-greased leading side of the rod has a fixed surface area (length and width) that sweeps a given length of air (circumference of the circle) for a given length of time. An advantage is that it is not affected by wind direction. A disadvantage is that it loses capture efficiency as the surface becomes loaded with impacted particles, explaining the necessity of not running it continually over 24 hours. Suction devices use vacuum pumps to move air through an aperture to impact on tape on a rotating drum (with the Burkard) or an advancing microscope slide (Kramer-Collins). The Burkard (Figure 20-1B) can be configured for a 24-hour or 7-day sample. Capture efficacy is best when the aperture is facing into the wind, and when the wind velocity matches the intake flow. The Burkard has a large weather vane to orient the

aperture into the wind. Another either indoor or outdoor suction device is the Andersen cascade impactor, which can segregate particles by size over several stages. Figures 20-1C and D show the Andersen intact and disassembled to show the individual stages. Agar plates can be used to identify fungi from culture characteristics. Small personal-sized samplers can be worn or carried and have been useful in risk assessment, especially in indoor occupational settings. High volume suction devices are fitted with fiberglass filters that can be scanned microscopically, or eluted and stained with specific monoclonal antibodies. The subtleties of outdoor sampling and interpretation as well as the importance of pauci-micronic particles carrying allergen has been described.<sup>22</sup> Immunochemical techniques to measure outdoor allergen have come into vogue.<sup>23,24</sup> Unfortunately, the number of pollen or fungal-related allergens contributing to the aeroallergen atmospheric burden exceeds by several orders of magnitude the number of monoclonal specific allergen immunochemical assays.

Outdoor aeroallergen sampling has been based on microscopic examination with identification based on morphologic pattern recognition, which is labor intensive and requires an experienced counter.<sup>25</sup> The National Allergy Bureau is the American Academy of Allergy, Asthma & Immunology (AAAAI) sponsored pollen-and-mold counting stations scattered primarily around the contiguous USA (with additional stations in Alaska, Hawaii, Puerto Rico, Canada and Argentina). The majority of over 85 stations have only a single qualified counter. Therefore, the prospect of automated systems is highly tantalizing. Conceptually elegant automated counters evaluated by Delaunay and associates have significant drawbacks.<sup>26</sup> The inability to discern ice particles from pollen by one sampler, and the relatively high particle detection threshold (above that necessary to induce symptoms in the majority of patients) are major problems. Work is progressing on computerized pattern recognition programs.

## Representative Pollens

### GRASSES

The huge grass family, Poaceae, has several subfamilies and numerous tribes. The Fescue subfamily, including the temperate climate pasture grasses and most cereal grains, is the most prominent in pollinosis. These grasses have wide range throughout the USA and Europe. With only minor exceptions, members of the Fescue subfamily have strongly cross-reactive major allergens.<sup>27</sup> Representative members include Kentucky bluegrass, timothy, and cereal rye (Figure 20-2A). Bermuda (*Cynodon dactylon*) is the most important southern grass, found south of the 38° parallel, with extension north along the coasts. Johnson (*Sorghum halepense*) is a southern grass, but is found throughout the Eastern Agricultural zone and across the Arid Southwest. Buffalo grass and grama grass are two native prairie grasses related to Bermuda grass.

### CONIFERS

The most important member of the order Coniferales is the cedar family (Cupressaceae), containing cedars, junipers (*Juniperus spp*, *Thuja spp*) and cypresses (*Cupressus spp*). Exposure is from forest stands, but also the ubiquitous use of junipers in home landscaping. In Texas and parts of Oklahoma,

TABLE 20-2 Types of Aeroallergen Samplers

Type	Example	Comment
Gravimetric	Durham Petrie dish	Large particles overrepresented Particles per surface area (p/cm <sup>2</sup> )
Volumetric		Particles per air volume (p/m <sup>3</sup> )
Impaction intermittent rotary suction drum	Rotorod Burkard	Easily overloaded Wind orientation necessary
cascade Filtration	Anderson Accu-Vol	Indoor or outdoor use Microscopic or immunoassay
Personal sampler		Clinically relevant exposure
Automatic counter	NTT-Shinyei KH300	Misreading likely Lack of sensitivity



**Figure 20-1** Aeroallergen samplers. A – Rotorod; B – Burkard spore trap; C – Andersen cascade impactor; D – Andersen sampler showing inner layers.

mountain cedar (*Juniperus ashei*) counts may be  $>20,000$  grains/ $m^3$ . Members of this family are strongly cross-reactive.<sup>27</sup> A subfamily includes bald cypress, redwoods, sequoias and the foremost producer of pollinosis in Japan, Japanese cedar (*Cryptomeria japonica*). The pine family consists of pines (*Pinus spp*), spruces (*Picea spp*), hemlocks (*Tsuga spp*) and firs (*Abies spp*, *Pseudotsuga*). This family produces copious amounts of pollen, but they are weak allergens and induce little hay fever.

#### OTHER TREES

Deciduous trees are scattered throughout a great number of botanical orders and families. With few exceptions, there is little

cross-reactivity between these diverse plants. Cottonwoods, aspens, poplars and willows are within the same family. Aspens are prevalent in the Rocky Mountains and throughout the Northern Forest. Poplars and cottonwoods are common throughout the eastern states and Great Plains. Willows, although primarily insect pollinated, may release significant amounts of airborne pollen. Several birch species (*Betula*) and alder (*Alnus*) are found throughout the Northern Forest, Northwest Coastal, California Lowlands and Great Basin. Alder is especially prevalent in the Northern Forest and Pacific Northwest zones. Red and white oaks (*Quercus spp*) have a wide range from the entire east through the Central Plains. Live oaks are evergreen and found throughout the Southern Tier. The



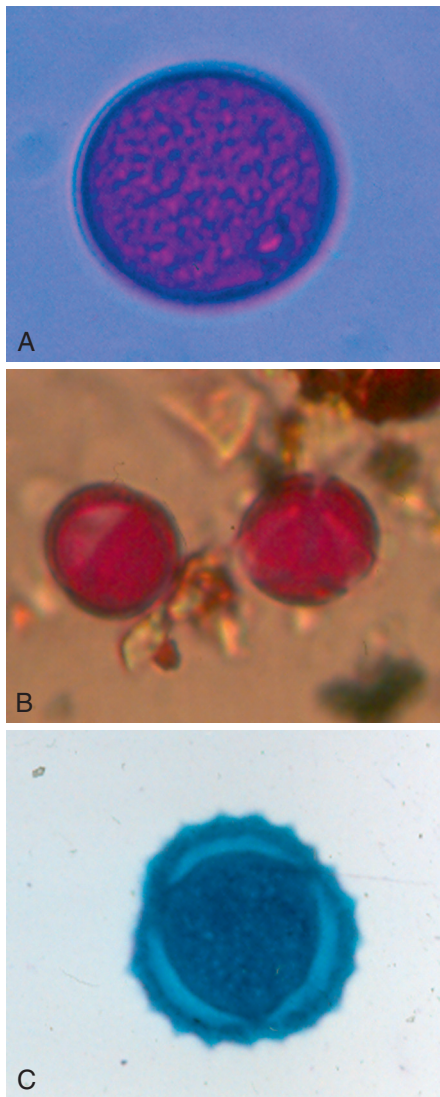

**Figure 20-2** Representative pollens. A – grass; B – maple; C – Ragweed.

American elm (*Ulmus americana*) has been decimated by disease, and the Siberian and Chinese elms (*U. pumila* and *U. parvifolia*) are now more common, with a similar wide range. Numerous maples (*Acer spp*) are found across the USA, with box elder (*A. negundo*) having a wide range in the Eastern zones, Central Plains, Rocky Mountain, Southwest and California Lowlands (Figure 20-2B). Box elder is an entirely wind-pollinated, prodigious pollen producer, while other maples are amphiphilous. Ash trees are found across the continent and have strong cross-reactivity with European olive. Linden, or basswood (*Tilia spp.*), is another amphiphilous tree that produces large amounts of airborne pollen in summer, causing significant sensitization. Russian olive (*Elaeagnus angustifolia*) has been widely planted across the Great Plains as a drought-resistant windbreak. It is both wind and insect pollinated.

## WEEDS

Numerous annual or perennial weeds are significant inducers of hay fever. The sorrels and docks pollinate earlier than many

weeds, coinciding with the grass pollen season. Sheep sorrel (*Rumex acetosella*) is considered a moderate hay fever inducer; curly or yellow dock (*R. crispus*), is a lower pollen producer but a common plant. Excepting the Florida and Southeast Coastal zones, nettle (*Urtica spp*) is common. Pellitory (*Parietaria spp*) is found throughout the zones. Under-appreciated as a source of hay fever, nettle produces large amounts of small, pale pollen. Pellitory is a major inducer of pollinosis in the Mediterranean basin. The closely related chenopod and amaranth weeds of Amaranthaceae are major inducers of hay fever in the later summer. Their pollen grains are very similar and difficult to discriminate by species. Pigweeds such as *Amaranthus retroflexus* are ubiquitous. The two major tumbleweeds found in the Central Plains, Russian thistle (*Salsola kali*) and burning bush (*Kochia scoparia*), are introduced and have expanded throughout the central states to the gulf and California coasts. Lamb's quarter (*Chenopodium album*), a modest pollen producer, has a worldwide distribution. Plantains (*Plantago spp*) are common weeds, which, while moderate pollen producers, have a long season, from spring into fall.

Short (*Ambrosia artemisiifolia*) and giant (*A. trifida*) ragweeds predominate in the eastern states through the Central Plains, with false (*A. acanthicarpa*) and western (*A. psilotachya*) ragweed common in the Rocky Mountain, Great Basin, Arid Southwest and California Lowlands (Figure 20-2C). These four major ragweed plants strongly cross-react.<sup>27</sup> Cocklebur (*Xanthium commune*) and the marshelders (*Iva spp*) are related to ragweed, but are of lesser significance. Mugwort (*Artemisia vulgaris*) in the east and several western sages (*Artemisia spp*) are important pollen producers in the late summer, rivaling the importance of ragweed in the western states. Goldenrod, *Solidago spp*, is a showy late summer flower which has been blamed for much of the misery caused by the less conspicuous ragweed. Although goldenrod and sunflower are primarily insect pollinated, they can release moderate amounts of pollen, which may persist at higher levels as ragweed pollen is waning.

## Representative Fungi

Long and Kramer demonstrated that airborne fungal spora should be classified as those facilitated by dry windy conditions, and those with greater spore release with increased humidity or precipitation.<sup>28</sup> In the Central Plains, fungi such as *Alternaria*, *Cladosporium* and *Epicoccum* grow on grasses and grains, and spores are released through wind turbulence. These mold spores are present in greatest concentrations on dry windy afternoons (Figure 20-3). Many Basidiomycetes and Ascomycetes have spore release dependent on increased humidity, and puffballs release spores when hit by raindrops. Such fungi will then be present in greatest concentrations during or after rainfall and during the damper hours of darkness.<sup>28</sup> Although *Alternaria* is recovered on samplers at an order of magnitude less than *Cladosporium*, it is a more potent allergenic source and has been incriminated in severe asthma and life-threatening events.<sup>29,30</sup> *Epicoccum* and basidiospores have also been linked with decreases in pulmonary function and asthma admissions.<sup>31,32</sup>

## Meteorological Variables

While the prevalent weather conditions help define climate, individual factors such as rain, humidity, wind speed and



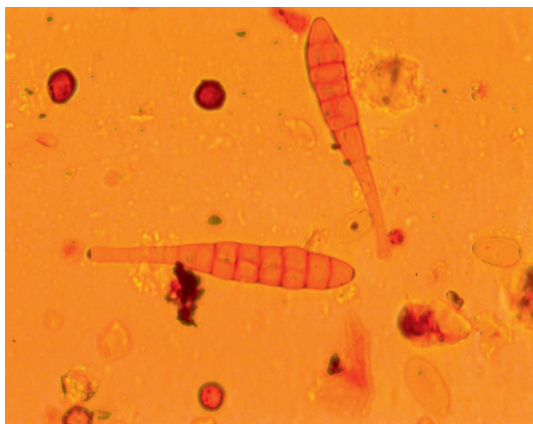

**Figure 20-3** *Alternaria*. Two club-shaped *Alternaria*; four clear cigar-shaped *Cladosporium* in lower right quadrant; two pairs of dark brown Basidiomycete smut spores in upper and lower left quadrants.

direction, temperature or amount of sunshine may all have effects on bioaerosols.<sup>33</sup> Effects may be immediate or cumulative. Precipitation and humidity decrease particle air burden acutely, while sufficient moisture preseasonally is necessary to assure proper growth of flower buds on perennials and trees, and growth of annuals in general. Ambient temperature rise is necessary for pollen anthesis in many plants, and cumulative heat above a threshold value has been linked to onset and intensity of pollination in grasses, weeds and trees.

Wind speed may factor in re-entrainment of settled particles or act to scour the air. Thunderstorms provide a sum of factors that may greatly increase aeroallergen burden due to outflows from storm cells as well as disruption of pollen grains with increase in airborne submicronic particles.<sup>34,35</sup>

Dispersal of mold spores is intimately linked to precipitation and humidity. However, effects may be diametrically opposed, depending on the type of fungi. Certain ascospores and basidiospores require active rainfall for release of spores, while other Deuteromycota will be suppressed by precipitation.

## KEY REFERENCES

- Weber RW. Pollen identification. *Ann Allergy Asthma Immunol* 1998;80:141–7.
- Schäppi GF, Taylor PE, Pain MCF, Cameron PA, Dent AW, Staff IA, et al. Concentrations of major grass group 5 allergens in pollen grains and atmospheric particles: implications for hay fever and allergic asthma sufferers sensitized to grass pollen allergens. *Clin Exp Allergy* 1999;29:633–41.
- Grote M, Swoboda I, Valenta R, Reichelt R. Group 13 allergens as environmental and immunological markers for grass pollen allergy: studies by immunogold field emission scanning and transmission electron microscopy. *Int Arch Allergy Immunol* 2005;136:303–10.
- Weber RW. Aeroallergen botany. *Ann Allergy Asthma Immunol* 2014;112:102–7.
- Weber RW. Floristic Zones and aeroallergen diversity. *Immunol Allergy Clin North Am* 2003;23:357–69.
- Long DL, Kramer CL. Air spora of two contrasting ecological sites in Kansas. *J Allergy Clin Immunol* 1972;49:255–66.
- O'Halloran MT, Yuninger JW, Offord KP, Somers MJ, O'Connell EJ, Ballard DJ, et al. Exposure to an aeroallergen as a possible precipitating factor in respiratory arrest in young patients with asthma. *N Engl J Med* 1991;324:359–63.
- Marks GB, Colquhoun JR, Girgis ST, Koski MH, Treloar AB, Hansen P, et al. Thunderstorm outflows preceding epidemics of asthma during spring and summer. *Thorax* 2001;56:468–71.
- Ziska LH, Gebhard DE, Frenz DA, Faulkner S, Singer BD, Straka JG. Cities as harbingers of climate change: common ragweed, urbanization, and public health. *J Allergy Clin Immunol* 2003;111:290–5.
- Shea KM, Truckner RT, Weber RW, Peden DB. Climate change and allergic disease. *J Allergy Clin Immunol* 2008;122:443–53.

## Impact of Climate Change on Aeroallergens

Pollen anthesis has been used as a monitor of anthropogenic climate change. Over a 16-year period, oak pollen onset in Poland advanced by 9 days, correlating with temperature increase.<sup>36</sup> Researchers have reported increased short ragweed (*A. artemisiifolia*) biomass and pollen production of 61–90% with increased ambient CO<sub>2</sub>.<sup>37,38</sup> Rogers and co-workers increased temperature to simulate early spring and found increased inflorescences and pollen in earlier compared to later blooming ragweed plants.<sup>39</sup> Increasing CO<sub>2</sub> also resulted in greater biomass and pollen production, more so in later growing cohorts. Since the content of Amb a 1 will vary in ragweed plants from site to site and from year to year, the question was raised whether increased pollen production necessarily implies an increase in airborne allergenic load.<sup>40,41</sup> Ziska and associates collected ragweed pollen along an urban transect in Maryland, using the urban environment as a surrogate for climate change.<sup>42</sup> The urban site averaged 2°C higher and the CO<sub>2</sub> level was 30% higher than in the rural site. The urban ragweed grew faster with a greater above-ground biomass, flowered earlier and produced more pollen than plants in the rural site. There was about a 2-fold greater concentration of Amb a 1 per microgram of protein in the rural versus the other sites. However, there was a >7-fold production of pollen from the urban sites compared to the rural site, documenting an increased airborne allergenic burden. The northern expansion of invasive ragweed in Europe has been linked to climate change.<sup>43</sup>

There is now a wealth of evidence that climate change has had, and will have further impact on a variety of allergenic plants.<sup>44,45</sup> Increased CO<sub>2</sub> increases plant biomass and pollen production. It is conceivable that increases in airborne pollen numbers will increase the efficiency of wind-borne pollination, thereby increasing propagation of such plants. The expectation then is that there will be increasing amounts of robust allergenic plants and an increasing aeroallergen burden for inhalant allergy sufferers. The rise of other pollutants in association with CO<sub>2</sub> may have a potentiating effect. Increased allergenicity of birch pollen has been linked with increased ozone levels.<sup>46</sup>

The complete reference list can be found on the companion Expert Consult website at <http://www.expertconsult.inkling.com>.

## REFERENCES

- Burge HA. Monitoring for airborne allergens. *Ann Allergy* 1992;69:9–18.
- Kendrick B. *The Fifth Kingdom*. Waterloo, Ontario, Canada: Mycologue Publications; 1985.
- Kraut A, Sloan J, Silviu-Dan F, Peng Z, Gagnon D, Warrington R. Occupational allergy after exposure to caddis flies at a hydroelectric power plant. *Occup Environ Med* 1994;51:408–13.
- Smith TS, Hogan MB, Welch JE, Corder WT, Wilson NW. Modern prevalence of insect sensitization in rural asthma and allergic rhinitis. *Allergy Asthma Proc* 2005;26:356–60.
- Elfman L, Brannstrom J, Smedje G. Detection of horse allergen around a stable. *Int Arch Allergy Immunol* 2008;145:269–76.
- Busse W, Reed C, Hoehne J. Where is the allergic reaction in ragweed asthma? II. Demonstration of ragweed antigen in airborne particles smaller than pollen. *J Allergy Clin Immunol* 1972;50:289–93.
- Habenicht HA, Burge HA, Muilenberg ML, Solomon WR. Allergen carriage by atmospheric aerosol. II. Ragweed-pollen determinants in submicronic atmospheric fractions. *J Allergy Clin Immunol* 1984;74:64–7.
- Weber RW. Pollen identification. *Ann Allergy Asthma Immunol* 1998;80:141–7.
- Schäppi GF, Taylor PE, Pain MCF, Cameron PA, Dent AW, Staff IA, et al. Concentrations of major grass group 5 allergens in pollen grains and atmospheric particles: implications for hay fever and allergic asthma sufferers sensitized to grass pollen allergens. *Clin Exp Allergy* 1999;29:633–41.
- Grote M, Vrtala S, Niederberger V, Valenta R, Reichelt R. Expulsion of allergen-containing materials from hydrated ryegrass (*Lolium perenne*) pollen revealed using immunogold field emission scanning and transmission electron microscopy. *J Allergy Clin Immunol* 2000;105:1140–5.
- Grote M, Swoboda I, Valenta R, Reichelt R. Group 13 allergens as environmental and immunological markers for grass pollen allergy: studies by immunogold field emission scanning and transmission electron microscopy. *Int Arch Allergy Immunol* 2005;136:303–10.
- Suphioglu C, Singh MB, Taylor PE, Bellomo R, Holmes P, Puy R, et al. Mechanism of grass-pollen-induced asthma. *Lancet* 1992;339:569–72.
- Weber RW. Aeroallergen botany. *Ann Allergy Asthma Immunol* 2014;112:102–7.
- Erdtman G. Output and dissemination of pollen. In: *An introduction to pollen analysis*. Waltham, MA: Chronica Botanica Co.; 1954. p. 175–85.
- Thommen AA. Which plants cause hayfever? In: *Asthma and hay fever in theory and practice*. Springfield, IL: Charles C. Thomas Publisher; 1931. p. 546–54.
- Weber RW. Floristic Zones and aeroallergen diversity. *Immunol Allergy Clin North Am* 2003;23:357–69.
- Williamson JF. *Sunset new western garden book*. 4th ed. Menlo Park, CA: Lane Publishing Co; 1979. p. 8–29.
- Solomon WR. Pollens and fungi. In: Middleton E Jr, Reed CE, Ellis EF, Adkinson NF Jr, Yunginger JW, Busse WW, editors. *Aerobiology and inhalant allergens, in allergy principles and practice*. 4th ed. St Louis: Mosby-Year Book, Inc.; 1993. p. 469–514.
- Solomon WR. Common pollen and fungus allergens. In: Bierman CW, Pearlman DS, editors. *Allergic Diseases from infancy to adulthood*. 2nd ed. Philadelphia: WB Saunders Co.; 1988. p. 141–64.
- Lewis WH, Vinay P, Zenger VE. *Airborne and allergenic pollen of North America*. Baltimore: Johns Hopkins University Press; 1983.
- Allergen nomenclature. International union of immunological societies allergen nomenclature subcommittee. updated 02-03-2009 <<http://www.allergen.org/Allergen.aspx>>.
- Solomon WR. How ill the wind? issues in aeroallergen sampling. *J Allergy Clin Immunol* 2003;112:3–8.
- Johnson CR, Weeke ER, Nielsen J, Jensen J, Mosbech H, Frølund L, et al. Aeroallergen analyses and their clinical relevance. II: sampling by high-volume air sampler with immunochemical quantification versus Burkard pollen trap sampling with morphologic quantification. *Allergy* 1992;47:510–16.
- Razmovski V, O'Meara TJ, Taylor DJM, Tovey ER. A new method for simultaneous immunodetection and morphologic identification of individual sources of pollen allergens. *J Allergy Clin Immunol* 2000;105:725–31.
- Weber RW. Outdoor aeroallergen sampling: not all that simple. *Ann Allergy Asthma Immunol* 2007;98:505–6.
- Delauney J-J, Sasajima H, Okamoto Y, Yokota M. Side-by-side comparison of automatic pollen counters for use in pollen information systems. *Ann Allergy Asthma Immunol* 2007;98:553–8.
- Weber RW. Guidelines for using pollen cross-reactivity in formulating allergen immunotherapy. *J Allergy Clin Immunol* 2008;122:219–21.
- Long DL, Kramer CL. Air spora of two contrasting ecological sites in Kansas. *J Allergy Clin Immunol* 1972;49:255–66.
- Zureik M, Neukirch C, Leynaert B, Liard R, Bosquet J, Neukirch F. Sensitisation to airborne moulds and severity of asthma: cross sectional study from European Community respiratory health survey. *Br Med J* 2002;325:411–17.
- O'Halloran MT, Yunginger JW, Offord KP, Somers MJ, O'Connell EJ, Ballard DJ, et al. Exposure to an aeroallergen as a possible precipitating factor in respiratory arrest in young patients with asthma. *N Engl J Med* 1991;324:359–63.
- Salvaggio J, Seabury J, Schoenhardt FA. New Orleans asthma. V. Relationship between Charity Hospital asthma admission rates, semi-quantitative pollen and fungal spore counts, and total particulate aerometric sampling data. *J Allergy Clin Immunol* 1971;48:96–114.
- Atkinson RW, Strachan DP, Anderson HR, Hajat S, Emberlin J. Temporal associations between daily counts of fungal spores and asthma exacerbations. *Occup Environ Med* 2006;63:580–90.
- Weber RW. Meteorological variables in aerobiology. *Immunol Allergy Clin North Am* 2003;23:411–22.
- Marks GB, Colquhoun JR, Girgis ST, Koski MH, Treloar AB, Hansen P, et al. Thunderstorm outflows preceding epidemics of asthma during spring and summer. *Thorax* 2001;56:468–71.
- Newsom R, Strachan D, Archibald E, Emberlin J, Hardaker P, Collier C. Effect of thunderstorms and airborne grass pollen on the incidence of acute asthma in England, 1990–94. *Thorax* 1997;52:680–5.
- Grewling Ł, Jackowiak B, Smith M. Variations in *Quercus* sp. Pollen seasons (1996–2011) in Poznań, Poland, in relation to meteorological parameters. *Aerobiologia* 2014;30:149–59.
- Ziska LH, Caulfield F. Rising CO<sub>2</sub> and pollen production of common ragweed (*Ambrosia artemisiifolia*), a known allergy-inducing species: implications for public health. *Aust J Plant Physiol* 2000;27:893–8.
- Wayne P, Foster S, Connelly J, Bazzaz F, Epstein P. Production of allergenic pollen by ragweed (*Ambrosia artemisiifolia* L.) is increased in CO<sub>2</sub>-enriched atmospheres. *Ann Allergy Asthma Immunol* 2002;88:279–82.
- Rogers CA, Wayne PM, Macklin EA, Muilenberg ML, Wagner CJ, Epstein PR, et al. Interaction of the onset of spring and elevated atmospheric CO<sub>2</sub> on ragweed (*Ambrosia artemisiifolia* L.) pollen production. *Environ Health Perspect* 2006;114:865–9.
- Lee YS, Dickinson DB, Schlager D, Velu JG. Antigen E content of pollen from individual plants of short ragweed (*Ambrosia artemisiifolia*). *J Allergy Clin Immunol* 1979;63:336–9.
- Weber RW. Mother Nature strikes back: global warming, homeostasis, and the implications for allergy. *Ann Allergy Asthma Immunol* 2002;88:251–2.
- Ziska LH, Gebhard DE, Frenz DA, Faulkner S, Singer BD, Straka JG. Cities as harbingers of climate change: common ragweed, urbanization, and public health. *J Allergy Clin Immunol* 2003;111:290–5.
- Storkey J, Stratonovitch P, Chapman DS, Vidotto F, Semenov MA. A process-based approach to predicting the effect of climate change on the distribution of an invasive allergenic plant in Europe. *PLoS ONE* 2014;9:e88156.
- Beggs PJ. Impacts of climate change on aeroallergens: past and future. *Clin Exp Allergy* 2004;34:13–2004.
- Shea KM, Truckner RT, Weber RW, Peden DB. Climate change and allergic disease. *J Allergy Clin Immunol* 2008;122:443–53.
- Beck I, Jochner S, Gilles S, McIntyre M, Buters JT, Schmidt-Weber C, et al. High environmental ozone levels lead to enhanced allergenicity of birch pollen. *PLoS ONE* 2013;8:e80147.

## KEY POINTS

- Studies in both inner city and suburban locations indicate that more than 80% of school age children with asthma are sensitized to at least one indoor allergen.
- The level of early life environmental exposure to a specific indoor allergen influences the development of sensitization to that allergen and subsequent atopic conditions.
- Humidity levels greater than 50% promote house dust mite growth and house dust mite allergy has been associated with asthma development, severity and morbidity.
- Given the lack of scientific evidence, it is standard for current guidelines to state that hypoallergenic cats and dogs should not be recommended for individuals who are sensitized.
- In urban environments, several important studies have demonstrated the relationship between cockroach exposure and poor asthma outcomes in children.

## Introduction

Allergens found in house dust have been associated with asthma since the 1920s, when Kern<sup>1</sup> and Cooke<sup>2</sup> independently reported a high prevalence of immediate skin tests to house dust extracts among patients with asthma. Van Leeuwen<sup>3</sup> showed that asthmatics who were admitted to a modified hospital room free of ‘climate allergens’ (thought to be bacteria and molds) showed clinical improvement. Allergists sought to explain how a heterogenous material such as house dust could contain a potent allergen that appeared to be ubiquitous. The puzzle was finally resolved in 1967, when Voorhorst and Spieksma<sup>4</sup> showed that the origin of house dust allergen was biologic. Extracts of mite cultures gave positive skin tests, and asthma symptoms correlated with seasonal variation in mite numbers. Exposure to 100 mites per gram of dust was associated with sensitization, and 500 mites per gram was associated with symptom exacerbation.

Over the past few decades, the investigation of the important role of indoor allergens in the pathogenesis of allergic disease has included the identification of the most important allergens, the evaluation of the effect of allergen exposure on allergic disease, and the development of techniques to accurately monitor allergen exposure. The primary indoor allergens include allergens from house dust mite, pets such as dogs and cats, molds, and pests such as cockroach and rodents. This chapter reviews the structure and biologic function of indoor allergens, the clinical significance of the primary indoor allergens and the methods for assessing environmental exposure.

## Allergen Structure and Function

Allergens are proteins or glycoproteins of 10 to 50 kDa that are readily soluble and able to penetrate the nasal and respiratory mucosae. A systematic allergen nomenclature has been developed by the International Union of Immunological Societies’ (IUIS) Allergen Nomenclature Subcommittee: the first three letters of the source genus followed by a single letter for the species and a number denoting the chronologic order of allergen identification. For example, the abbreviated nomenclature for the house dust mite allergen, *Dermatophagoides pteronyssinus* allergen 1, is Der p 1 (see <http://www.allergen.org>). To be included in the IUIS nomenclature, the allergen must have been purified to homogeneity and/or cloned, and the prevalence of IgE antibody must have been established in an appropriate allergic population by skin testing or in vitro IgE antibody assays.<sup>5</sup> Molecular cloning has determined the primary amino acid sequences of more than 500 allergens and most common allergens can be manufactured as recombinant proteins. There are over 50 three-dimensional structures of allergens in the Protein Database (PDB) and allergens are found in protein families in the Pfam protein family database (<http://www.sanger.ac.uk/software/Pfam>).<sup>5–10</sup>

The x-ray crystal structures of Der p 1 and Der f 1 (*Dermatophagoides farinae* 1) are shown in Figure 21-1.<sup>11</sup> It is noted that only a small percentage of the more than 10,000 protein families in Pfam are allergens. This implies that only a limited group of proteins (with certain structural features) have the potential to become allergens;<sup>6,12</sup> however, detailed structural analyses have not revealed any common features or motifs that are associated with the induction of IgE responses.

Allergens belong to protein families with diverse biologic functions including enzymes, enzyme inhibitors, lipid-binding proteins, ligand-binding proteins, structural proteins or regulatory proteins (Box 21-1).<sup>5</sup> Some dust mite allergens are digestive enzymes excreted with the feces, such as Der p 1 (cysteine protease), Der p 3 (serine protease) and Der p 6 (chymotrypsin). Enzymatic activity of mite allergens promotes IgE synthesis and local inflammatory responses via cleavage of CD23 and CD25 receptors on B cells and by causing the release of proinflammatory cytokines (interleukin [IL]-8, IL-6, monocyte chemoattractant protein-1 [MCP-1] and granulocyte-monocyte colony-stimulating factor [GM-CSF]) from bronchial epithelial cells.<sup>13</sup> Mite protease allergens cause detachment of bronchial epithelial cells in vitro and disrupt intercellular tight junctions. Activation of mite proteases could damage lung epithelia and allow access of other nonenzymatic allergens, such as Der p 2, to antigen-presenting cells. Der p 2 has structural homology to MD-2, the lipopolysaccharide (LPS) binding component of the Toll-like receptor 4 (TLR4) complex. Recent studies have shown that Der p 2 can drive signaling of the TLR4 complex and may enhance the expression of TLR4 on the airway



epithelium and have intrinsic adjuvant activity.<sup>14</sup> Mite feces contain other elements, including endotoxin, bacterial DNA, mite DNA and chitin that could also influence IgE responses and inflammation.<sup>15,16</sup>

With the exception of cat allergen Fel d 1 (*Felis domesticus* 1), most animal allergens are ligand-binding proteins (lipocalins) or albumins. Lipocalins are 20–25kDa proteins with a conserved, eight-stranded, antiparallel  $\beta$ -barrel structure that bind and transport small hydrophobic chemicals. In contrast, Fel d 1 is a calcium-binding, steroid-inducible, uteroglobin-like molecule – a tetrameric 35 kDa glycoprotein, comprising two subunits which are heterodimers of two chains comprising eight  $\alpha$ -helices.<sup>17</sup> Fel d 1 has two amphipathic water-filled cavities which may bind biologically important ligands. Rat and mouse urinary allergens are pheromone- or odorant-binding

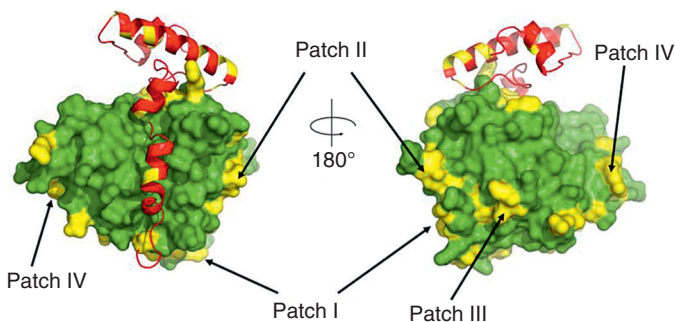

**Figure 21-1** X-ray crystal structures of the mite cysteine protease allergens, Der p 1 and Der f 1. Residues that differ between the two allergens are shown in yellow and labeled as patches I, II, III and IV. The conserved Cys35 active site residue is shown in orange. (From Chruszcz M, Chapman M, Vailes L, et al. *J Mol Biol* 2009;386:520–30.)

### BOX 21-1 KEY CONCEPTS

#### Indoor Allergens: Structure and Function

- Allergens are soluble proteins or glycoproteins of molecular weights of 10 to 50 kDa.
- More than 500 allergen sequences are deposited in protein databases (GenBank, PDB), and more than 50 tertiary structures have been resolved by x-ray crystallography.
- Allergens have diverse biologic functions and may be enzymes, enzyme inhibitors, lipid-binding proteins, lipocalins or regulatory or structural proteins.
- Allergens promote T cells to differentiate along the Th2 pathway to produce IL-4 and IL-13 and to initiate isotype switching to IgE.
- Biologic functions of allergens, such as proteolytic enzyme activity or other adjuvant-like effects, can enhance IgE responses, damage lung epithelium and cause allergic inflammation.

proteins. The cockroach allergen Bla g 4 (*Blattella germanica* 4) is a lipocalin that is produced in utricles and conglobate glands of male cockroaches and may have a reproductive function. Other important cockroach allergens include: Bla g 1, a gut-associated allergen; Bla g 2, an inactive aspartic proteinase; Bla g 5 (glutathione transferase family); and the Group 7 tropomyosin allergens.<sup>18</sup>

## Clinical Significance of Indoor Allergens

Exposure data collected in epidemiologic studies, population surveys and birth cohort studies have strengthened the association between indoor allergen exposure and the pathogenesis of allergic respiratory diseases including asthma and allergic rhinitis. The measurement of indoor allergen levels in dust and air samples has allowed for the determination of risk levels for allergen exposure leading to both sensitization and symptom exacerbation. International workshop reports recommend that allergen exposure be expressed as  $\mu\text{g}$  allergen/gram dust ( $\mu\text{g}/\text{g}$ ) for dust samples or  $\text{ng}/\text{m}^3$  for air samples.<sup>8</sup> Childhood asthma is more closely linked to allergic sensitization and allergen exposure than adult asthma. Sensitization to indoor allergens likely occurs earliest in life as young children have been shown to have higher rates of sensitization to indoor allergens as compared to outdoor allergens.<sup>9</sup> Studies in both inner city and suburban children with asthma indicated that more than 80% of school age children with asthma are sensitized to at least one indoor allergen and that allergic sensitization is a strong predictor of disease persistence in later life.<sup>10,19,20</sup> In one large inner city study, 94% of the study population of severe asthmatics was sensitized to at least one allergen and the number of sensitivities correlated with asthma severity.<sup>21</sup> Furthermore, European cohorts have demonstrated that high-level allergen exposure in early life is associated with chronic asthma in children.<sup>10,20</sup> Epidemiologic studies have demonstrated risk of allergic sensitization to be attributable to certain levels of allergen exposure among different populations of atopic individuals (Table 21-1).

## DUST MITES

The two principal mite species, *D. pteronyssinus* (Der p) and *D. farinae* (Der f), account for more than 90% of the mite fauna in US house dust samples. Other allergenic mites include *Euroglyphus maynei* and *Blomia tropicalis* (found in subtropical regions such as Florida, southern California, Texas and Puerto Rico). Storage mites, such as *Lepidoglyphus destructor*, *Tyrophagus putrescentiae* and *Acarus siro*, cause occupational asthma among farmers, farm workers and grain handlers.

TABLE 21-1

### Allergen Exposure Thresholds for Sensitization

Risk for Sensitization*	ALLERGEN LEVEL IN DUST SAMPLE				
	Mite Group 1 ( $\mu\text{g}/\text{g}$ )	Fel d 1 ( $\mu\text{g}/\text{g}$ )	Can f 1 ( $\mu\text{g}/\text{g}$ )	Bla g 1 (U/g)	Bla g 2 ( $\mu\text{g}/\text{g}$ )
Low	<0.3 <sup>†</sup>	<0.5 or >20	<0.5 or >20?	<0.6	<0.08
Medium	2–10	8–20	8–20	1–8	0.08–0.4
High	>10	1–8	1–8	>8	>1

\*For atopic children.

<sup>†</sup>Levels found in 'allergen-free' hospital rooms or in houses/apartments maintained for at least 6 months at less than 45% relative humidity.



House dust mites (Der p and Der f) are found in dust and products with woven material or stuffing such as mattresses, pillows, stuffed animals and bedding. Warmth and humidity greater than 50% are the major factors that promote dust mite growth. Rabito et al found that, in New Orleans, asthmatic children living indoors with average humidity greater than 50% were three times more likely to be exposed to elevated levels of house dust mites.<sup>22</sup> In contrast, house dust mite levels are generally low or undetectable in areas of high altitude or low humidity. In fact, maintaining an indoor humidity below 50% is one of the recommended components of interventions to reduce dust mite exposure.<sup>23</sup>

More than 50% of children and adolescents with asthma are sensitized to house dust mites.<sup>24</sup> There is strong evidence for a dose-response relationship of exposure to house dust mites and sensitization in both cross-sectional<sup>25–27</sup> and prospective studies.<sup>20,28–30</sup> Mite allergen levels at high altitude or in ‘allergen-free’ rooms are generally <0.3 µg/g and <10% of atopic individuals are likely to become sensitized at this low level of mite exposure. Persistent exposure of atopic individuals to ≈2 µg of mite allergen is likely to result in sensitization in a majority of atopic individuals, increasing as mite allergen levels exceed 2 µg/g (Table 21-1). A prospective study of German schoolchildren demonstrated a 7-fold increase in sensitization to dust mites between children exposed to dust mite allergen levels in the first quartile (<0.3 µg/g) as compared to those exposed in the highest quartile (1–240 µg/g).<sup>30</sup> Exposure to dust mite allergen levels greater than 10 µg/g is considered high risk for sensitization, and findings from the National Survey of Lead and Allergens in Housing (NSLAH) indicate that these levels are found in ≈23% of US homes (22 million housing units).<sup>31</sup>

Asthma development,<sup>32–35</sup> severity<sup>36</sup> and morbidity<sup>24,26</sup> have been strongly associated with house dust mite allergy. Dust mite exposure influences the development of asthma by exposure leading to sensitization and subsequent asthma symptoms. Sporik et al demonstrated dust mite exposure to be an important factor in the development of childhood asthma, particularly if there was exposure to high levels in the first year of life.<sup>20</sup> The relative risk of asthma was almost five times greater in the subjects who were exposed to high levels of dust mite allergen (>10 µg/g). Tovey et al showed a nonlinear relationship between levels of dust mites in homes and the development of asthma at 5 years of age in a high risk cohort of children.<sup>29</sup> The trends showed increasing prevalence of sensitization and asthma correlating with dust mite exposure up to a critical point and then sharply dropping at the highest level of exposure (>23.40 µg/g for Der p 1). The explanation of attenuated disease development with very high levels of dust mite exposure is unclear but may indicate that high concentrations of nonallergenic immune modifiers such as endotoxin are accompanying the house dust mites. Celedon et al found a dose response relationship between levels of dust mite exposure in high risk infants at age 2–3 months and asthma at school age.<sup>28</sup> In this study, the high allergen threshold was ≥10 µg/g, much lower than the critical threshold found in Tovey’s evaluation. A survey of middle school children in Virginia showed that dust mite sensitization was independently associated with asthma (OR 6.6,  $P < .0001$ ) and that dust from 81% of homes contained more than 2 µg/g mite group 1 allergen.<sup>33</sup> In addition to the implications for developing asthma, sensitization to dust mites predicts worse lung function as compared to those not sensitized.<sup>24</sup>

## PETS (CAT AND DOG)

The major cat allergen, *Felis domesticus* 1 (Fel d 1), is primarily found in cat skin and hair follicles and is produced in sebaceous, anal and salivary glands. The major dog allergen, *Canis familiaris* 1 (Can f 1), is found in hair, dander and saliva. What distinguishes pet allergen exposure from other indoor allergens is the wide range of exposure levels (from <0.5 to >3000 µg/g) and the ubiquitous allergen distribution. The small particles of cat and dog allergen can scatter easily in the air and adhere to clothing for further dispersal.<sup>37,38</sup> As such, these allergens are found in non-pet homes, schools and public places.<sup>38–46</sup>

Data on cat and dog allergen exposure in relation to sensitization are more difficult to interpret as there is a nonlinear relationship.<sup>25</sup> This nonlinear relationship of pet allergen exposure and risk of sensitization is seen in Table 21-1. Exposure to Fel d 1 of <0.5 µg/g is considered to be low and is a low risk for sensitization.<sup>27</sup> Paradoxically, the prevalence of sensitization is also reduced among atopic individuals who are continuously exposed to high levels of Fel d 1 (>20 µg/g).<sup>25,47,48</sup> This high level of exposure appears to reduce the prevalence of sensitization by ≈50%. High exposure to Fel d 1 (>20 µg/g) gives rise to a modified Th2 response – a form of tolerance that results in a lower prevalence of IgE antibody responses. Studies have demonstrated that infants exposed to the highest levels of cat allergen had decreased cat-specific IgE levels and high allergen-specific IgG levels corresponding to a low risk phenotype for atopy.<sup>49,50</sup> This helps to explain why early exposure to cat has been found protective for asthma and other atopic conditions.<sup>51,52</sup> The nonlinear dose response may also explain why, in population surveys, sensitization to cats is often lower than that to dust mites. In countries such as New Zealand, where 78% of the population owns cats and high levels of allergen occur in houses, the prevalence of sensitization to cat is only 10% and cat is not as important a cause of asthma as dust mites.<sup>53</sup> Most houses that contain cats or dogs have Fel d 1 or Can f 1 levels of greater than 10 µg/g, whereas homes that do not contain these pets usually have allergen levels of 1 to 10 µg/g, placing those inhabitants at the highest risk for sensitization.<sup>39,43,44</sup>

In addition to risk of sensitization, studies have demonstrated that cat allergen exposure early in life is associated with the development of asthma.<sup>35,54,55</sup> In geographic areas where dust mite levels are low, dog and cat have been found to be the primary allergens associated with asthma.<sup>43</sup> Increased exposure in sensitized individuals may lead to higher rates of asthma; however, a Norwegian study reported that cat exposure led to an increased risk of asthma independent of cat sensitization.<sup>56</sup> This result indicates a possible nonallergic mechanism. Regardless, an already sensitized child who lives in a home without a cat can become symptomatic by visiting homes or attending schools where cat allergen is present, even if those locations do not physically have any cats. Schools are the best example of this phenomenon. A Swedish study showed a 9-fold increased risk of asthma exacerbations at school among elementary schoolchildren who attended classes with other students from cat homes as compared to children who attended classes with fewer than 18% cat owners.<sup>57</sup> Thus, passive exposure of schoolchildren to animal allergens can exacerbate asthma, even among asthmatic children who are purposely avoiding pets.

Similar to cat allergen, dog allergen has a nonlinear dose-response relationship between exposure and development of sensitization. A medium-dose exposure of Fel d 1 (1–8 µg/g) is

most strongly associated with the development of sensitization as seen in Table 21-1. Dog exposure and asthma is less studied. A recent meta-analysis noted a slightly increased, statistically significant, relative risk of asthma in pet owners, not taking into account allergic sensitization.<sup>52</sup> Other birth cohort studies have not been suggestive of an association.<sup>58</sup>

Recently, issues regarding so-called 'hypoallergenic' pets have arisen. Many pet companies have aggressively marketed the benefits of these pets. It is important to stress that there is no scientific evidence to support the existence of 'hypoallergenic' pets.<sup>59-61</sup> In fact, Vredegoor et al actually found higher levels of Can f 1 in hair and fur samples of 'hypoallergenic' dog breeds as compared to non-hypoallergenic breeds.<sup>61</sup> In the homes of these pets, the same study found that there were not any differences in Can f 1 levels in settled floor dust or air samples between the two groups. Currently, it is standard for guidelines to state that hypoallergenic cats and dogs should not be recommended for individuals who are sensitized.<sup>59</sup>

## COCKROACH

The German (*Blattella germanica*) and American (*Periplaneta americana*) cockroaches are the most common species to cause allergies. The major allergens, Bla g 1, Bla g 2 and Per a 1, are found in saliva, fecal material, secretions, cast skins and debris. Urban environments, low socioeconomic status, multifamily homes and old buildings are risk factors for cockroach infestation and higher levels of cockroach allergen.<sup>62,63</sup> The National Cooperative Inner-City Asthma Study (NCICAS) found that 85% of collected dust samples had detectable levels of cockroach allergen.<sup>64</sup> In public housing residences of New York City, 77% were found to have evidence of cockroaches.<sup>65</sup> Cockroach allergen exposure is typically assessed by measuring Bla g 1 and Bla g 2, which cause sensitization in 30% and 60% of cockroach-allergic patients, respectively.<sup>66</sup> Most dust samples from cockroach-infested homes contain both allergens, and there is a modest, but significant, correlation between levels of the two allergens.<sup>67</sup>

Increased cockroach exposure leads to increased risk of sensitization. Although the highest levels of cockroach allergen are typically found in kitchens, Eggleston et al demonstrated that the bedroom concentration of cockroach allergen was most associated with cockroach sensitization.<sup>19</sup> More recent work by Chew et al showed this relationship to be dose responsive between inner city home cockroach level and cockroach sensitization in children.<sup>68</sup> Cockroach allergens appear to be particularly potent. Atopic individuals develop IgE-specific responses after exposure to 10-fold to 100-fold lower levels of cockroach allergen as compared to dust mite or cat.<sup>27</sup>

Several important studies have demonstrated the relationship between cockroach exposure and poor asthma outcomes in children.<sup>21,64</sup> Most notably, Rosenstreich et al demonstrated that asthmatic children living in inner cities who were sensitized to cockroach and exposed to high levels of cockroach allergen (>8 U/g) had significantly more frequent hospitalizations, more days with wheezing, more unscheduled medical visits for asthma, more missed school days and more nights with lost sleep.<sup>64</sup> This study demonstrates the important principle of allergic disease – that sensitization plus exposure leads to symptoms. In that inner city study, similar patterns were not found for the combination of sensitization to dust mites or cat and exposure to higher levels. A follow-up study confirmed these findings with cockroach allergen having a greater effect on

asthma morbidity in the inner city as compared to dust mite or pet allergens.<sup>21</sup> These findings underscore the importance of cockroach allergen as a major factor in asthma control for children living in urban environments. Additionally, cockroach allergen exposure has been shown to increase the risk of development of childhood wheeze in longitudinal studies.<sup>69-71</sup>

## MOUSE

The major mouse allergens are *Mus musculus* 1 and 2 (Mus m 1 and Mus m 2). These allergens are found in mouse urine, dander and hair.<sup>72</sup> The allergen can be found in homes with and without mice infestation as the allergens easily migrate on dust particles.<sup>73</sup> Factors that increase mouse infestation are high population density (high rise apartments and multifamily dwellings), clutter and integrity of the residence. It is one of the few allergens to span environments from inner city to suburban areas, affecting both homes and schools.<sup>45,46,74,75</sup> Phipatanakul et al found that 95% of inner city homes in multiple US cities had detectable mouse allergen levels and the highest levels in those homes were found in the kitchens.<sup>75</sup> Similar rates of detectable mouse allergen have been discovered in urban schools and the levels of mouse allergen found in those schools can be higher than the surrounding homes.<sup>45,46</sup>

Data from inner city studies have shown that subjects living in homes with higher mouse allergen concentrations had significantly higher rates of mouse sensitization.<sup>76</sup> In sensitized individuals, exposure to mouse allergen affects clinical asthma outcomes, leading to increased asthma morbidity.<sup>77,78</sup> Furthermore, exposure to mouse allergen may lead directly to asthma development. Early life mouse exposure was shown to be associated with increased risk of wheezing in early life.<sup>79</sup> Likewise, current mouse exposure was associated with current wheeze through 7 years of age; however, early mouse exposure in infancy did not predict later wheeze or asthma at 7 years of age.<sup>79</sup> Mouse allergen may lead to current wheeze by acting as a direct irritant, as seen in laboratory workers.<sup>80</sup> Additionally, mouse allergen exposure may lead to sensitization, which has been significantly associated with wheezing in the early years of life.<sup>70</sup>

## Evaluation of Allergen Exposure

Allergens are typically measured in dust samples that are collected by either vacuuming settled dust (on the floor or furniture) or gathering airborne dust from filtered air within a room. Samples may be collected from multiple sites within a home, including mattresses, bedding, bedroom or living room carpet, soft furnishings or kitchen floors. After dust collection, fine dust can then be extracted for further testing and analysis. For dust mite evaluation, collection of dust in bedding and mattresses provides the best marker of exposure.<sup>81</sup> Cat and dog allergens are widely distributed throughout the house. Not surprisingly, the highest concentrations of cockroach and mouse allergens are usually found in kitchens, although in heavily infested homes allergen accumulates throughout the home.

The decision to sample dust or air has to account for the aerodynamic properties of allergens.<sup>44,82,83</sup> Dust mite and cockroach allergens occur on large particles (10–40 µm in diameter) and cannot be detected in rooms under undisturbed conditions. After a disturbance, such as using a vacuum cleaner without a filter, these particles remain airborne for only a short time of approximately 20 to 40 minutes. In contrast, cat and

dog allergens can be carried on small airborne particles (1–20 µm in diameter) allowing for easier detection in air samples under undisturbed conditions and persistence in the air for several hours.<sup>84</sup> While airborne, pet allergens are easily able to adhere to clothing for further dispersal.

After collection, filtered dust is sent to accredited labs for extraction, analysis and evaluation of the concentrations of specific allergens within the specific dust sample. Since the 1980s, measurement of major allergens within the dust samples has been made by using monoclonal antibody (mAb)-based ELISA (enzyme-linked immunosorbent assays). ELISA methods have defined specificity and high sensitivity (≈1 ng/mL) and provide accurate and reproducible measurements.<sup>8,85</sup> A growing number of academic and commercial laboratories in the USA and in Europe offer ELISA testing services. While ELISA provides reliable quantitative exposure assessment, it does require a separate test for each allergen. More recently, innovative fluorescent multiplex array technology has been developed that allows the most common indoor allergens to be detected at once in a single test using a multiplex array for indoor allergens (MARIA).<sup>86,87</sup> The multiplex test occurs within a single microtiter well and the assay conditions are the same for each allergen, resulting in improved standardization and reproducibility. The other advantage of MARIA compared to ELISA is the time savings achieved by analyzing multiple allergens at once. For allergen exposure assessment, nine indoor allergens can be measured by MARIA: Der p 1, Der f 1, mite group 2, Fel d 1, Can f 1, Mus m 1, Rat n 1, Bla g 2 and Alt a 1.

## Monitoring Allergen Exposure as Part of Asthma Management

The most recent National Asthma Education and Prevention Program (NAEPP) Expert Panel Report 3 (EPR-3) significantly strengthened guidelines recommending allergen avoidance as an important goal of asthma management (Box 21-2). Targeted interventions in the homes of allergic individuals can significantly improve health and should be part of the management of children with asthma. Studies of inner city asthma demonstrated that reduction of indoor allergen exposure leads to improvement of asthma symptoms, associated with a reduced use of medication and also a reduction in lost work or school time due to asthma.<sup>88</sup> The guidelines recommend using patient histories and allergic sensitization as evidence of allergen

### BOX 21-2 THERAPEUTIC PRINCIPLES

#### Control of Environmental Factors that Affect Asthma (NAEPP EPR-3)

- For patients who have persistent asthma, the clinician should evaluate the potential role of indoor allergens.
- Use the patient's medical history, skin testing or in vitro testing to identify allergen exposures that may worsen the patient's asthma.
- Patients who have asthma at any level of severity should reduce, if possible, exposure to allergens to which the patient is sensitized and exposed.
- Know that effective allergen avoidance requires a multifaceted, comprehensive approach.
- Consider allergen immunotherapy when there is clear evidence of a relationship between symptoms and exposure to an allergen to which the patient is sensitive.

exposure but do not include any environmental assessment. Targeted indoor allergen avoidance strategies must account for geographical considerations and living conditions to attempt to identify the specific troublesome exposures for that patient.

## Conclusions

Indoor allergens are a risk factor for the development of asthma as well as other allergic diseases. Indoor allergens have diverse biologic functions and may be enzymes, lipid-binding proteins, ligand-binding proteins, structural proteins or regulatory proteins. The biologic function of allergens may enhance IgE responses and play a direct role in causing allergic inflammation. The level of environmental exposure to allergen as well as the atopic predisposition of the individual also influences the development of IgE responses and Th2 responses. The NAEPP-EPR 3 guidelines for the management of asthma recommend that for any patient with persistent asthma, the clinician should: (1) identify allergen exposures; (2) use skin testing or in vitro testing to assess specific sensitivities to indoor allergens; and (3) implement environmental controls to reduce exposure to relevant allergens. Avoidance procedures that can help to reduce exposure to indoor allergens have been developed and can reduce symptoms and medication requirements.

The complete reference list can be found on the companion Expert Consult website at <http://www.expertconsult.inkling.com>.

## KEY REFERENCES

- Gore JC, Schal C. Cockroach allergen biology and mitigation in the indoor environment. *Annu Rev Entomol* 2007;52:439–63.
- Sporik R, Holgate ST, Platts-Mills TA, Cogswell JJ. Exposure to house-dust mite allergen (Der p 1) and the development of asthma in childhood. A prospective study. *N Engl J Med* 1990;323:502–7.
- Platts-Mills T, Vaughan J, Squillace S, Woodfolk J, Sporik R. Sensitisation, asthma, and a modified Th2 response in children exposed to cat allergen: a population-based cross-sectional study. *Lancet* 2001;357:752–6.
- Lau S, Illi S, Sommerfeld C, Niggemann B, Bergmann R, von Mutius E, et al. Early exposure to house-dust mite and cat allergens and development of childhood asthma: a cohort study. *Multicentre Allergy Study Group. Lancet* 2000; 356:1392–7.
- Almqvist C, Larsson PH, Egmar AC, Hedren M, Malmberg P, Wickman M. School as a risk environment for children allergic to cats and a site for transfer of cat allergen to homes. *J Allergy Clin Immunol* 1999;103:1012–17.
- Bollinger ME, Eggleston PA, Flanagan E, Wood RA. Cat antigen in homes with and without cats may induce allergic symptoms. *J Allergy Clin Immunol* 1996;97:907–14.
- Owby DR, Johnson CC, Peterson EL. Exposure to dogs and cats in the first year of life and risk of allergic sensitization at 6 to 7 years of age. *JAMA* 2002;288:963–72.
- Sears MR, Greene JM, Willan AR, Wiecek EM, Taylor DR, Flannery EM, et al. A longitudinal, population-based, cohort study of childhood asthma followed to adulthood. *N Engl J Med* 2003;349:1414–22.
- Rosenreich DL, Eggleston P, Kattan M, Baker D, Slavin RG, Gergen P, et al. The role of cockroach allergy and exposure to cockroach allergen in causing morbidity among inner-city children with asthma. *N Engl J Med* 1997; 336:1356–63.
- Phipatanakul W, Eggleston PA, Wright EC, Wood RA. Mouse allergen. II. The relationship of mouse allergen exposure to mouse sensitization and asthma morbidity in inner-city children with asthma. *J Allergy Clin Immunol* 2000;106:1075–80.



## REFERENCES

- Kern RA. Dust sensitization in bronchial asthma. *Med Clin North Am* 1921;5:751–8.
- Cooke RA. Studies in specific hypersensitivity. IV. New aetiological factors in bronchial asthma. *J Immunol* 1922;7:147–62.
- van Leeuwen SW. Asthma and tuberculosis in relation to 'climate allergens'. *Br Med J* 1927;2:344–7.
- Voorhorst R, Spiekma F, Leupen M. The house dust mite (*Dermatophagoides pteronyssinus*) and the allergens it produces. Identity with the house dust allergen. *J Allergy* 1967;39:325–39.
- Chapman MD, Pomes A, Breiteneder H, Ferreira F. Nomenclature and structural biology of allergens. *J Allergy Clin Immunol* 2007;119:414–20.
- Radauer C, Breiteneder H. Pollen allergens are restricted to few protein families and show distinct patterns of species distribution. *J Allergy Clin Immunol* 2006;117:141–7.
- Li M, Gustchina A, Alexandratos J, Wlodawer A, Wunschmann S, Kepley CL, et al. Crystal structure of a dimerized cockroach allergen Bla g 2 complexed with a monoclonal antibody. *J Biol Chem* 2008;283:22806–14.
- Platts-Mills TA, Vervloet D, Thomas WR, Aalberse RC, Chapman MD. Indoor allergens and asthma: report of the Third International Workshop. *J Allergy Clin Immunol* 1997;100(6 Pt 1):S2–24.
- Sheehan WJ, Rangsitienchai PA, Baxi SN, Gardynski A, Bharmanee A, Israel E, et al. Age-specific prevalence of outdoor and indoor aeroallergen sensitization in Boston. *Clin Pediatr (Phila)* 2010;49:579–85.
- Illis S, von Mutius E, Lau S, Niggemann B, Gruber C, Wahn U. Perennial allergen sensitization early in life and chronic asthma in children: a birth cohort study. *Lancet* 2006;368:763–70.
- Chruszcz M, Chapman MD, Vailes LD, Stura EA, Saint-Remy JM, Minor W, et al. Crystal structures of mite allergens Der f 1 and Der p 1 reveal differences in surface-exposed residues that may influence antibody binding. *J Mol Biol* 2009;386:520–30.
- Radauer C, Bublin M, Wagner S, Mari A, Breiteneder H. Allergens are distributed into few protein families and possess a restricted number of biochemical functions. *J Allergy Clin Immunol* 2008;121:847–52 e7.
- Shakib F, Ghaemmaghami AM, Sewell HF. The molecular basis of allergenicity. *Trends Immunol* 2008;29:633–42.
- Trompette A, Divanovic S, Visintin A, Blanchard C, Hegde RS, Madan R, et al. Allergenicity resulting from functional mimicry of a Toll-like receptor complex protein. *Nature* 2009;457:585–8.
- Platts-Mills TA. The role of indoor allergens in chronic allergic disease. *J Allergy Clin Immunol* 2007;119:297–302.
- Dickey BF. Exoskeletons and exhalation. *N Engl J Med* 2007;357:2082–4.
- Kaiser L, Velickovic TC, Badia-Martinez D, Adedoyin J, Thunberg S, Hallen D, et al. Structural characterization of the tetrameric form of the major cat allergen Fel d 1. *J Mol Biol* 2007;370:714–27.
- Gore JC, Schal C. Cockroach allergen biology and mitigation in the indoor environment. *Annu Rev Entomol* 2007;52:439–63.
- Eggleston PA, Rosenstreich D, Lynn H, Gergen P, Baker D, Kattan M, et al. Relationship of indoor allergen exposure to skin test sensitivity in inner-city children with asthma. *J Allergy Clin Immunol* 1998;102(4 Pt 1):563–70.
- Sporik R, Holgate ST, Platts-Mills TA, Cogswell JJ. Exposure to house-dust mite allergen (Der p 1) and the development of asthma in childhood. A prospective study. *N Engl J Med* 1990;323:502–7.
- Gruchalla RS, Pongracic J, Plaut M, Evans R 3rd, Visness CM, Walter M, et al. Inner City Asthma Study: relationships among sensitivity, allergen exposure, and asthma morbidity. *J Allergy Clin Immunol* 2005;115:478–85.
- Rabito FA, Iqbal S, Holt E, Grimsley LF, Islam TM, Scott SK. Prevalence of indoor allergen exposures among New Orleans children with asthma. *J Urban Health* 2007;84:782–92.
- Wright LS, Phipatanakul W. Environmental remediation in the treatment of allergy and asthma: latest updates. *Curr Allergy Asthma Rep* 2014;14:419.
- Ulrik CS, Backer V. Markers of impaired growth of pulmonary function in children and adolescents. *Am J Respir Crit Care Med* 1999;160:40–4.
- Platts-Mills T, Vaughan J, Squillace S, Woodfolk J, Sporik R. Sensitisation, asthma, and a modified Th2 response in children exposed to cat allergen: a population-based cross-sectional study. *Lancet* 2001;357:752–6.
- Dotterud LK, Van TD, Kvammen B, Dybendal T, Elsayed S, Falk ES. Allergen content in dust from homes and schools in northern Norway in relation to sensitization and allergy symptoms in schoolchildren. *Clin Exp Allergy* 1997;27:252–61.
- Sporik R, Squillace SP, Ingram JM, Rakes G, Honsinger RW, Platts-Mills TA. Mite, cat, and cockroach exposure, allergen sensitisation, and asthma in children: a case-control study of three schools. *Thorax* 1999;54:675–80.
- Celedon JC, Milton DK, Ramsey CD, Litonjua AA, Ryan L, Platts-Mills TA, et al. Exposure to dust mite allergen and endotoxin in early life and asthma and atopy in childhood. *J Allergy Clin Immunol* 2007;120:144–9.
- Tovey ER, Almqvist C, Li Q, Crisafulli D, Marks GB. Nonlinear relationship of mite allergen exposure to mite sensitization and asthma in a birth cohort. *J Allergy Clin Immunol* 2008;122:114–18, 8 e1–5.
- Lau S, Illis S, Sommerfeld C, Niggemann B, Bergmann R, von Mutius E, et al. Early exposure to house-dust mite and cat allergens and development of childhood asthma: a cohort study. Multicentre Allergy Study Group. *Lancet* 2000;356:1392–7.
- Arbes SJ Jr, Cohn RD, Yin M, Muilenberg ML, Burge HA, Friedman W, et al. House dust mite allergen in US beds: results from the First National Survey of Lead and Allergens in Housing. *J Allergy Clin Immunol* 2003;111:408–14.
- Carter PM, Peterson EL, Ownby DR, Zoratti EM, Johnson CC. Relationship of house-dust mite allergen exposure in children's bedrooms in infancy to bronchial hyperresponsiveness and asthma diagnosis by age 6 to 7. *Ann Allergy Asthma Immunol* 2003;90:41–4.
- Squillace SP, Sporik RB, Rakes G, Couture N, Lawrence A, Merriam S, et al. Sensitization to dust mites as a dominant risk factor for asthma among adolescents living in central Virginia. Multiple regression analysis of a population-based study. *Am J Respir Crit Care Med* 1997;156:1760–4.
- Arshad SH, Tariq SM, Matthews S, Hakim E. Sensitization to common allergens and its association with allergic disorders at age 4 years: a whole population birth cohort study. *Pediatrics* 2001;108:E33.
- Sears MR, Herbison GP, Holdaway MD, Hewitt CJ, Flannery EM, Silva PA. The relative risks of sensitivity to grass pollen, house dust mite and cat dander in the development of childhood asthma. *Clin Exp Allergy* 1989;19:419–24.
- Kovac K, Dodig S, Tjesic-Drinkovic D, Raos M. Correlation between asthma severity and serum IgE in asthmatic children sensitized to *Dermatophagoides pteronyssinus*. *Arch Med Res* 2007;38:99–105.
- De Lucca SD, O'Meara TJ, Tovey ER. Exposure to mite and cat allergens on a range of clothing items at home and the transfer of cat allergen in the workplace. *J Allergy Clin Immunol* 2000;106:874–9.
- Almqvist C, Larsson PH, Egmar AC, Hedren M, Malmberg P, Wickman M. School as a risk environment for children allergic to cats and a site for transfer of cat allergen to homes. *J Allergy Clin Immunol* 1999;103:1012–17.
- Bollinger ME, Eggleston PA, Flanagan E, Wood RA. Cat antigen in homes with and without cats may induce allergic symptoms. *J Allergy Clin Immunol* 1996;97:907–14.
- Giovannangelo M, Gehring U, Nordling E, Oldenwening M, de Wind S, Bellander T, et al. Childhood cat allergen exposure in three European countries: the AIRALLERG study. *Sci Total Environ* 2006;369:82–90.
- Custovic A, Green R, Taggart SC, Smith A, Pickering CA, Chapman MD, et al. Domestic allergens in public places. II: Dog (Can f 1) and cockroach (Bla g 2) allergens in dust and mite, cat, dog and cockroach allergens in the air in public buildings. *Clin Exp Allergy* 1996;26:1246–52.
- Roost HP, Kunzli N, Schindler C, Jarvis D, Chinn S, Perruchoud AP, et al. Role of current and childhood exposure to cat and atopic sensitization. European Community Respiratory Health Survey. *J Allergy Clin Immunol* 1999;104:941–7.
- Ingram JM, Sporik R, Rose G, Honsinger R, Chapman MD, Platts-Mills TA. Quantitative assessment of exposure to dog (Can f 1) and cat (Fel d 1) allergens: relation to sensitization and asthma among children living in Los Alamos, New Mexico. *J Allergy Clin Immunol* 1995;96:449–56.
- Custovic A, Green R, Fletcher A, Smith A, Pickering CA, Chapman MD, et al. Aerodynamic properties of the major dog allergen Can f 1: distribution in homes, concentration, and particle size of allergen in the air. *Am J Respir Crit Care Med* 1997;155:94–8.
- Permaul P, Hoffman E, Fu C, Sheehan W, Baxi S, Gaffin J, et al. Allergens in urban schools and homes of children with asthma. *Pediatr Allergy Immunol* 2012;23:543–9.
- Sheehan WJ, Rangsitienchai PA, Muilenberg ML, Rogers CA, Lane JP, Ghaemghami J, et al. Mouse allergens in urban elementary schools and homes of children with asthma. *Ann Allergy Asthma Immunol* 2009;102:125–30.
- Ownby DR, Johnson CC, Peterson EL. Exposure to dogs and cats in the first year of life and risk



- of allergic sensitization at 6 to 7 years of age. *JAMA* 2002;288:963–72.
48. Custovic A, Hallam CL, Simpson BM, Craven M, Simpson A, Woodcock A. Decreased prevalence of sensitization to cats with high exposure to cat allergen. *J Allergy Clin Immunol* 2001;108:537–9.
  49. Lau S, Illi S, Platts-Mills TA, Riposo D, Nickel R, Gruber C, et al. Longitudinal study on the relationship between cat allergen and endotoxin exposure, sensitization, cat-specific IgG and development of asthma in childhood – report of the German Multicentre Allergy Study (MAS 90). *Allergy* 2005;60:766–73.
  50. Platts-Mills TA, Vaughan JW, Blumenthal K, Pollart Squillace S, Sporik RB. Serum IgG and IgG4 antibodies to Fel d 1 among children exposed to 20 microg Fel d 1 at home: relevance of a nonallergic modified Th2 response. *Int Arch Allergy Immunol* 2001;124:126–9.
  51. Hesselmar B, Aberg N, Aberg B, Eriksson B, Björkstén B. Does early exposure to cat or dog protect against later allergy development? *Clin Exp Allergy* 1999;29:611–17.
  52. Takkouche B, Gonzalez-Barcala FJ, Etmninan M, Fitzgerald M. Exposure to furry pets and the risk of asthma and allergic rhinitis: a meta-analysis. *Allergy* 2008;63:857–64.
  53. Sears MR, Greene JM, Willan AR, Wiecek EM, Taylor DR, Flannery EM, et al. A longitudinal, population-based, cohort study of childhood asthma followed to adulthood. *N Engl J Med* 2003;349:1414–22.
  54. Polk S, Sunyer J, Munoz-Ortiz L, Barnes M, Torrent M, Figueroa C, et al. A prospective study of Fel d1 and Der p1 exposure in infancy and childhood wheezing. *Am J Respir Crit Care Med* 2004;170:273–8.
  55. Torrent M, Sunyer J, Garcia R, Harris J, Iturriaga MV, Puig C, et al. Early-life allergen exposure and atopy, asthma, and wheeze up to 6 years of age. *Am J Respir Crit Care Med* 2007;176:446–53.
  56. Bertelsen RJ, Carlsen KC, Carlsen KH, Granum B, Doeke G, Haland G, et al. Childhood asthma and early life exposure to indoor allergens, endotoxin and beta(1,3)-glucans. *Clin Exp Allergy* 2010;40:307–16.
  57. Almqvist C, Wickman M, Perfetti L, Berglund N, Renstrom A, Hedren M, et al. Worsening of asthma in children allergic to cats, after indirect exposure to cat at school. *Am J Respir Crit Care Med* 2001;163(3 Pt 1):694–8.
  58. Celedon JC, Litonjua AA, Ryan L, Platts-Mills T, Weiss ST, Gold DR. Exposure to cat allergen, maternal history of asthma, and wheezing in first 5 years of life. *Lancet* 2002;360:781–2.
  59. Portnoy J, Kennedy K, Sublett J, Phipatanakul W, Matsui E, Barnes C, et al. Environmental assessment and exposure control: a practice parameter – furry animals. *Ann Allergy Asthma Immunol* 2012;108:223 e1–15.
  60. Butt A, Rashid D, Lockey RF. Do hypoallergenic cats and dogs exist? *Ann Allergy Asthma Immunol* 2012;108:74–6.
  61. Vredegoor DW, Willemse T, Chapman MD, Heederik DJ, Krop EJ. Can f 1 levels in hair and homes of different dog breeds: lack of evidence to describe any dog breed as hypoallergenic. *J Allergy Clin Immunol* 2012;130:904–9 e7.
  62. Sheehan WJ, Rangsitienchai PA, Wood RA, Rivard D, Chinratanapit S, Perzanowski MS, et al. Pest and allergen exposure and abatement in inner-city asthma: a work group report of the American Academy of Allergy, Asthma & Immunology Indoor Allergy/Air Pollution Committee. *J Allergy Clin Immunol* 2010;125:575–81.
  63. Cohn RD, Arbes SJ Jr, Jaramillo R, Reid LH, Zeldin DC. National prevalence and exposure risk for cockroach allergen in U.S. households. *Environ Health Perspect* 2006;114:522–6.
  64. Rosenstreich DL, Eggleston P, Kattan M, Baker D, Slavin RG, Gergen P, et al. The role of cockroach allergy and exposure to cockroach allergen in causing morbidity among inner-city children with asthma. *N Engl J Med* 1997;336:1356–63.
  65. Chew GL, Carlton EJ, Kass D, Hernandez M, Clarke B, Tiven J, et al. Determinants of cockroach and mouse exposure and associations with asthma in families and elderly individuals living in New York City public housing. *Ann Allergy Asthma Immunol* 2006;97:502–13.
  66. Satinover SM, Reefer AJ, Pomes A, Chapman MD, Platts-Mills TA, Woodfolk JA. Specific IgE and IgG antibody-binding patterns to recombinant cockroach allergens. *J Allergy Clin Immunol* 2005;115:803–9.
  67. Arruda LK, Vailes LD, Ferriani VP, Santos AB, Pomes A, Chapman MD. Cockroach allergens and asthma. *J Allergy Clin Immunol* 2001;107:419–28.
  68. Chew GL, Perzanowski MS, Canfield SM, Goldstein IF, Mellins RB, Hoepner LA, et al. Cockroach allergen levels and associations with cockroach-specific IgE. *J Allergy Clin Immunol* 2008;121:240–5.
  69. Litonjua AA, Milton DK, Celedon JC, Ryan L, Weiss ST, Gold DR. A longitudinal analysis of wheezing in young children: the independent effects of early life exposure to house dust endotoxin, allergens, and pets. *J Allergy Clin Immunol* 2002;110:736–42.
  70. Donohue KM, Al-Alem U, Perzanowski MS, Chew GL, Johnson A, Divjan A, et al. Anti-cockroach and anti-mouse IgE are associated with early wheeze and atopy in an inner-city birth cohort. *J Allergy Clin Immunol* 2008;122:914–20.
  71. Silva JM, Camara AA, Tobias KR, Macedo IS, Cardoso MR, Arruda E, et al. A prospective study of wheezing in young children: the independent effects of cockroach exposure, breast-feeding and allergic sensitization. *Pediatr Allergy Immunol* 2005;16:393–401.
  72. Phipatanakul W. Rodent allergens. *Curr Allergy Asthma Rep* 2002;2:412–16.
  73. Ohman JL Jr, Hagberg K, MacDonald MR, Jones RR Jr, Paigen BJ, Kacergis JB. Distribution of airborne mouse allergen in a major mouse breeding facility. *J Allergy Clin Immunol* 1994;94:810–17.
  74. Crain EF, Walter M, O'Connor GT, Mitchell H, Gruchalla RS, Kattan M, et al. Home and allergic characteristics of children with asthma in seven U.S. urban communities and design of an environmental intervention: the Inner-City Asthma Study. *Environ Health Perspect* 2002;110:939–45.
  75. Phipatanakul W, Eggleston PA, Wright EC, Wood RA. Mouse allergen. I. The prevalence of mouse allergen in inner-city homes. The National Cooperative Inner-City Asthma Study. *J Allergy Clin Immunol* 2000;106:1070–4.
  76. Phipatanakul W, Eggleston PA, Wright EC, Wood RA. Mouse allergen. II. The relationship of mouse allergen exposure to mouse sensitization and asthma morbidity in inner-city children with asthma. *J Allergy Clin Immunol* 2000;106:1075–80.
  77. Matsui EC, Eggleston PA, Buckley TJ, Krishnan JA, Breyse PN, Rand CS, et al. Household mouse allergen exposure and asthma morbidity in inner-city preschool children. *Ann Allergy Asthma Immunol* 2006;97:514–20.
  78. Pongracic JA, Visness CM, Gruchalla RS, Evans R 3rd, Herman EM. Effect of mouse allergen and rodent environment intervention on asthma in inner-city children. *Ann Allergy Asthma Immunol* 2008;101:35–41.
  79. Phipatanakul W, Celedon JC, Hoffman EB, Abdulkerim H, Ryan LM, Gold DR. Mouse allergen exposure, wheeze and atopy in the first seven years of life. *Allergy* 2008;63:1512–18.
  80. Gautrin D, Ghezzi H, Infante-Rivard C, Malo JL. Natural history of sensitization, symptoms and occupational diseases in apprentices exposed to laboratory animals. *Eur Respir J* 2001;17:904–8.
  81. Custovic A, Taggart SC, Niven RM, Woodcock A. Evaluating exposure to mite allergens. *J Allergy Clin Immunol* 1995;96:134–5.
  82. Luczynska CM, Li Y, Chapman MD, Platts-Mills TA. Airborne concentrations and particle size distribution of allergen derived from domestic cats (*Felis domesticus*). Measurements using cascade impactor, liquid impinger, and a two-site monoclonal antibody assay for Fel d I. *Am Rev Respir Dis* 1990;141:361–7.
  83. de Blay F, Heymann PW, Chapman MD, Platts-Mills TA. Airborne dust mite allergens: comparison of group II allergens with group I mite allergen and cat-allergen Fel d I. *J Allergy Clin Immunol* 1991;88:919–26.
  84. de Blay F, Chapman MD, Platts-Mills TA. Airborne cat allergen (Fel d I). Environmental control with the cat in situ. *Am Rev Respir Dis* 1991;143:1334–9.
  85. Chapman MD, Tsay A, Vailes LD. Home allergen monitoring and control – improving clinical practice and patient benefits. *Allergy* 2001;56:604–10.
  86. Earle CD, King EM, Tsay A, Pittman K, Saric B, Vailes L, et al. High-throughput fluorescent multiplex array for indoor allergen exposure assessment. *J Allergy Clin Immunol* 2007;119:428–33.
  87. King EM, Vailes LD, Tsay A, Satinover SM, Chapman MD. Simultaneous detection of total and allergen-specific IgE by using purified allergens in a fluorescent multiplex array. *J Allergy Clin Immunol* 2007;120:1126–31.
  88. Morgan WJ, Crain EF, Gruchalla RS, O'Connor GT, Kattan M, Evans R 3rd, et al. Results of a home-based environmental intervention among urban children with asthma. *N Engl J Med* 2004;351:1068–80.

## KEY POINTS

- The major indoor allergens include dust mite, animal danders, cockroach, rodents and mold.
- Indoor allergen exposure and sensitivity should be considered for all patients with chronic allergic symptoms, including asthma, allergic rhinitis and atopic dermatitis.
- Allergen avoidance should be considered the first line of therapy for patients with indoor allergen sensitivities.
- Allergen avoidance should be approached with a comprehensive specific environmental control strategy based on the patient's sensitivities and exposures.

There is no doubt that aeroallergens play a major role in the pathogenesis of allergic disease, including asthma, allergic rhinitis and atopic dermatitis. Among these, the indoor allergens are of particular importance. These principally include the allergens of house dust mites, domestic pets, molds and pests such as cockroaches and rodents. The relative importance of these different allergens varies in different environments depending on a variety of geographic, climatic and socioeconomic factors. All studies agree, however, that children with asthma have a high likelihood of becoming sensitized to whichever of these allergens are prominent in their local environments. This chapter focusses on the possible role that allergen avoidance may play in the management of allergic disease.

As a general concept, it is important to recognize that allergen avoidance should be based on knowledge of the patient's specific allergic sensitivities as well as their environmental exposures. Based on this information, it is important to recommend a comprehensive strategy to reduce exposure to as many relevant allergens as possible. In fact, most of the studies in which environmental control has been proven effective are those that utilize a multifaceted approach tailored to the patient's sensitivities and environment,<sup>1-6</sup> which requires both thoughtful consideration and detailed patient education.

### Dust Mites

Dust mites are arachnids that live in the dust that accumulates in most homes, particularly the dust contained within fabrics. Favorite habitats include carpets, upholstered furniture, mattresses, pillows and bedding materials. Their major food source is shed human skin scales, which are present in high numbers in most of these items. The major dust mite species known to be associated with allergic disease are *Dermatophagoides pteronyssinus* and *Dermatophagoides farinae*.<sup>1,7-9</sup> Other mites,

including *Euroglyphus maynei* and *Blomia tropicalis*, are also important in some areas, although their distribution is considerably more limited. Dust mites grow optimally in areas that are both warm and humid, and they grow very poorly when the relative humidity remains below 40%.<sup>10</sup> Dust mites grow from eggs to adults over the course of about 4 weeks and adult dust mites live for about 6 weeks, during which time females produce 40 to 80 eggs.<sup>11</sup>

Assessment of dust mite exposure has been accomplished largely through the analysis of settled dust samples. Although some studies have not been able to show a relationship between dust mite levels and allergic sensitization or disease activity, there is now general agreement that dust mite levels of greater than 2 µg of group 1 allergen per gram of dust should be considered a risk factor for sensitization and that levels greater than 10 µg/g of dust are a risk factor for increased asthma morbidity.<sup>9,11-15</sup> Airborne sampling for dust mite allergen has not proven useful in assessing exposure.<sup>16</sup>

The prevalence of dust mite sensitivity in patients with asthma or allergic rhinitis varies considerably from one geographic area to another. For example, studies have demonstrated sensitization rates ranging from 5% in asthmatic children in Los Alamos, New Mexico, to 66% in Atlanta, Georgia, to 91% in Papua, New Guinea.<sup>17,18</sup> These differences are roughly proportional to differences in mite exposure in these areas of the world.

In addition to the relationship between mite exposure and mite sensitization, there is also evidence that mite exposure contributes to the development of asthma.<sup>1</sup> In a prospective trial, Sporik and colleagues<sup>14</sup> demonstrated a significant increase in asthma, as well as mite sensitivity, in 11-year-old children who had experienced high mite exposure during infancy. Other studies have demonstrated a striking association between asthma development and mite sensitivity,<sup>17,19-21</sup> although these studies lacked a prospective evaluation of mite exposure. While these studies suggest that mite avoidance early in life could potentially prevent the development of asthma, studies of prevention have yielded inconsistent and mostly disappointing results.<sup>22-29</sup>

Extensive evidence also exists to support a relationship between ongoing mite exposure and disease activity.<sup>1,30-33</sup> With regard to chronic symptoms, Vervloet and colleagues<sup>32</sup> demonstrated a significant correlation between medication requirements and current mite exposure in a group of mite-sensitive adult asthma patients. Custovic and colleagues<sup>30</sup> also demonstrated a relationship between mite exposure and asthma severity as evidenced by bronchial hyperreactivity (BHR), peak expiratory flow rate variability and forced expiratory volume in 1 second (FEV<sub>1</sub>). Several studies have also demonstrated mite exposure to be a risk factor for acute asthma and emergency room visits.<sup>15,33</sup> The most compelling evidence for the role of dust mites in asthma comes from studies of allergen avoidance,<sup>1</sup>

either through environmental control in the home or the removal of mite-allergic patients from their homes. Two classic studies from the early 1980s provided dramatic evidence for the potential benefits of dust mite avoidance. Platts-Mills and colleagues<sup>34</sup> investigated the effects of mite avoidance by placing nine young adults with mite-induced asthma in a hospital setting for a minimum of 2 months. All patients experienced reduced symptoms, seven had reduced medication requirements, and five showed at least an 8-fold reduction in bronchial reactivity. In the second study Murray and Ferguson<sup>35</sup> studied 20 mite-allergic asthmatic children in a controlled trial of mite avoidance in the patients' homes. They found significant reductions in asthma symptoms, days on which wheezing was observed, days with low peak flow rates, and BHR in the group using active mite control measures.

Most subsequent trials of mite avoidance have yielded similar results.<sup>36–40</sup> Ehnert and colleagues<sup>38</sup> studied 24 children with asthma and mite sensitivity in a 1-year trial of mite avoidance. The patients were divided into three groups. The first had their mattresses, pillows and comforters covered with impermeable encasements; the second had their mattresses and carpets treated with an acaricide (benzyl benzoate); and the third had their mattresses and carpets treated with placebo. Significant reductions in dust mite allergen levels were found only in the group with mattress and pillow encasements. Similarly, a highly significant reduction in BHR was noted in that group compared with the other two. In another study, Peroni and colleagues<sup>40</sup> studied mite avoidance by moving asthmatic children to a high-altitude environment and demonstrated significant reductions in total immunoglobulin E (IgE) levels, dust mite-specific IgE levels, methacholine reactivity and response to dust mite bronchoprovocation.

However, it is also important to recognize that there have been several important negative studies of mite avoidance, especially when using a single intervention such as bedding encasements,<sup>41–43</sup> and that meta-analyses on the efficacy of mite avoidance have yielded conflicting results.<sup>44–49</sup> For example, in one study Woodcock and colleagues studied the efficacy of impermeable bed covers in over 1,100 adults with asthma and dust mite sensitivity.<sup>47</sup> While the impermeable covers resulted in significant decreases in mite allergen in mattress dust, asthma symptoms were not significantly reduced. These studies again point to the need for a comprehensive allergen reduction plan rather than relying on single interventions.

## DUST MITE CONTROL MEASURES

Although a variety of approaches to dust mite control have been studied, there is still some controversy as to the specific measures that are necessary to reduce mite exposure sufficiently to control disease. This controversy arises for three major reasons. First, some environmental control measures have not been adequately studied to make any firm conclusions. Second, for some measures, studies of their efficacy have yielded conflicting results. Third, in many studies a combination of environmental control measures was used, making it difficult to determine which measures actually led to the benefit that was observed. Specific environmental control measures will therefore be reviewed individually. They are summarized in [Box 22-1](#).

It is very clear that allergen-proof encasements for mattresses and pillows significantly reduce dust mite exposure.<sup>1,38,48–50</sup> In the study by Ehnert and colleagues,<sup>38</sup> polyurethane

### BOX 22-1 ENVIRONMENTAL CONTROL OF HOUSE DUST MITES

#### FIRST LINE (NECESSARY AND COST EFFECTIVE)

- Encase mattresses and pillows
- Wash bed linens every 1 to 2 weeks, preferably in hot water
- Remove stuffed toys
- Regularly vacuum carpeted surfaces
- Regularly dust hard surfaces
- Reduce indoor relative humidity (dehumidify and do not add humidity)

#### SECOND LINE (HELPFUL BUT MORE EXPENSIVE)

- Remove carpets, especially in the bedroom
- Remove upholstered furniture
- Avoid living in basements

#### THIRD LINE (LIMITED OR UNPROVEN BENEFIT)

- Acaricides
- Tannic acid
- Air cleaners

mattress encasements produced a 91% decrease in mite allergen by day 14 of treatment, which rose to 98% by month 12 of the study. Encasements of the mattress, pillows and box springs should therefore be recommended for all patients with mite sensitivity. In addition, although encasements had been constructed of impermeable plastic or vinyl materials that were very uncomfortable, they are now also available in tightly woven fabrics that are considerably more comfortable.<sup>51</sup>

The effects of vacuum cleaning on mite exposure have been studied. Live mites are difficult to remove from carpeting, and it is clear that vacuum cleaning in the absence of other measures will provide only limited benefit.<sup>1</sup> However, regular vacuum cleaning does remove significant amounts of dust from carpets, which will at least help to reduce the allergen reservoir. Patients should also be warned that vacuuming creates considerable disturbance, with transient increases in airborne mite levels. Vacuum cleaners equipped with special bags or HEPA filters help prevent this problem and may be of some added benefit.<sup>52</sup> There is some evidence that wet vacuum cleaning or steam cleaning may provide additional benefit,<sup>53,54</sup> although one study showed that wet vacuum cleaning led to a subsequent increase in mite numbers.<sup>55</sup>

A variety of carpet treatments, including acaricides such as benzyl benzoate and denaturing agents such as tannic acid, have also been developed in an effort to control dust mite allergen exposure. At best, both approaches provide only modest, short-lived effects and should not be recommended for routine use.<sup>1,37,56,57</sup>

Because of the limitations of both vacuuming and chemically treating carpets, carpet removal is always best when feasible, especially from the bedroom of the allergic person. Bed linens, stuffed animals and other soft furnishings also provide excellent environments for dust mite growth. Objects such as stuffed animals should be removed whenever possible. The mite content of bedding materials and other objects that cannot be removed can be reduced by washing. Washing in hot water (greater than 55°C) is ideal in that it both removes allergen and kills dust mites.<sup>58</sup> These water temperatures, however, may not be available in many homes due to safety concerns. It is important to note, therefore, that washing in cooler water does not kill mites but does remove most live mites as well as mite

allergens very effectively. Weekly washing of all bed linens in a hot cycle is therefore recommended for all mite-allergic patients. Dry cleaning also kills dust mites,<sup>59,60</sup> as does tumble drying at temperatures greater than 55°C for at least 20 minutes.<sup>48</sup>

Dust mites are susceptible to the effects of low as well as high temperatures. Freezing in a typical household freezer for 24 hours will kill most dust mites, although the mite allergen in the object will not necessarily be reduced.<sup>61</sup> Exposing carpets to direct sunlight for several hours will also kill dust mites because of the high temperature, the low humidity or both.<sup>62</sup> It has also been shown that electric blankets will reduce mite growth.<sup>4,63</sup> None of these methods have been established in clinical trials.

Because of the reliance of dust mites on humidity for growth, it has been suggested that methods capable of reducing relative humidity would be useful in the control of mite exposure. Korsgaard and Iversen<sup>64</sup> demonstrated that dust mite growth could be significantly reduced by keeping indoor humidity below 7 g/kg by ventilation, whereas Arlian<sup>65</sup> demonstrated that mite growth could be prevented by maintaining relative humidity below 35% for at least 22 hours a day. Air conditioning and dehumidification may also help to deter mite growth and should be used whenever possible; humidifiers should be avoided.<sup>66</sup> It is clear, however, that achieving low humidity will be difficult or impossible in very humid environments. A prime example of this fact is the difficulty in eliminating dust mites from carpets over cement slab floors in basements.

Finally, air filtration devices are frequently purchased by patients for the control of their dust mite allergies; however, there is little evidence to support their use.<sup>67-70</sup> One would logically not anticipate much effect because of the fact that dust mite allergens do not remain airborne for extended periods and would therefore not be available for filtration in most instances.

In summary, effective dust mite control can be accomplished in most homes with a combination of mattress and pillow covers, hot washing of bed linens, removal of stuffed animals and other soft furnishings, and carpet removal.<sup>1</sup> Because of the convincing benefits provided through dust mite avoidance in mite-sensitive asthmatic patients, these measures should be routinely recommended, and compliance with these recommendations should be reassessed at each subsequent visit.

## Animal Allergens

Animal allergens are also potent causes of both acute and chronic asthma and allergy symptoms.<sup>4,71</sup> Cat and dog allergens are the most important, although significant exposure to a wide variety of other furred animals is not uncommon. Sensitivity to cat and dog allergens is very common in asthmatic children, and in some settings these are clearly the dominant indoor allergens.<sup>18,72,73</sup> This fact was best demonstrated in a study conducted in Los Alamos, New Mexico.<sup>18</sup> In this environment, where cat and dog allergens are common but exposure to dust mite and cockroach allergens is rare, IgE antibody to cat and dog allergens was detected in 62% and 67% of asthmatic children, respectively. The presence of this IgE antibody was highly associated with asthma, whereas sensitivity to mite or cockroach allergen was not associated with asthma in this setting.

A number of studies have investigated the distribution of cat and dog allergens in the home and other environments.<sup>4,18,73-76</sup> Using settled dust analysis, it has been shown that levels of cat and dog allergens are clearly highest in homes housing these animals. However, it is also clear from a number of studies that

the vast majority of homes contain cat and dog allergen even if a pet has never lived there. This widespread distribution of cat and dog allergens has also been documented in a variety of other settings, including office buildings and schools. Whereas most of the environments with no animals have relatively low allergen levels compared to those with a cat or dog, it is not uncommon to find rather high levels in some of these homes. This widespread distribution is presumed to occur primarily through passive transfer of allergen from one environment to another. The particles carrying animal allergens appear to be very sticky and, unlike dust mite allergens, can be found in high levels on walls and other surfaces within homes.<sup>77</sup>

The characteristics of airborne cat allergen have also been extensively studied. Cat allergen has been shown to be carried on particles that range from less than 1 µm to greater than 20 µm in mean aerodynamic diameter.<sup>78,79</sup> Although estimates have varied, studies agree that at least 15% of airborne cat allergen is carried on particles less than 5 µm. Dog allergen is distributed very much like cat allergen, with about 20% of airborne dog allergen being carried on particles less than 5 µm in diameter.<sup>80</sup>

Cat allergen can also be detected in air samples from all homes with cats and from many homes without cats.<sup>81</sup> In an attempt to determine the clinical significance of this unsuspected cat exposure, patients were challenged in an experimental cat exposure facility to varying levels of cat allergen.<sup>81</sup> It was found that allergen levels of less than 100 ng/m<sup>3</sup> were capable of inducing upper and lower respiratory symptoms as well as significant pulmonary function changes. These levels are similar to those found in homes with cats as well as a subset of homes without cats, suggesting that even patients without known cat exposure may be exposed to clinically significant concentrations of airborne cat allergen on a regular basis.

## CONTROL OF ANIMAL ALLERGENS

At the present time much less is known about the control of animal allergens than about the control of dust mite allergens.<sup>82</sup> In particular, there are still very few studies on the clinical benefit of environmental control measures for animal allergens. Although it is assumed that removing an animal from the home will lead to clinical improvement in patients who have disease related to their pets, even this simple concept has undergone little investigation. One prospective study did evaluate patients with asthma who were sensitized to furry animals, with some choosing to find their pet a new home and others electing to keep it. After 1 year, there was a significant improvement in airway hyperresponsiveness and a reduction in inhaled corticosteroid use in the pet removal group compared with the pet keeping group.<sup>83</sup> Even fewer data are available regarding the potential benefits of methods that might be used in lieu of animal removal. The overall approach to the control of animal allergens is summarized in [Box 22-2](#).

To begin, it should be stated that in any asthmatic patient who is known to be cat or dog sensitive and whose asthma is believed to be related to a significant degree to the pet, the most appropriate recommendation is to remove the pet from the home. This is clearly the correct advice from a medical standpoint, and it should be recommended strenuously. A number of potential alternative measures will also be discussed, however, because of the high proportion of patients who are either reluctant or completely unwilling to remove a household pet.



### BOX 22-2 ENVIRONMENTAL CONTROL OF ANIMAL ALLERGENS

Remove source (e.g. find a new home for the pet):

- Allergen levels fall slowly – benefit would not be expected for weeks to months.
- Follow by aggressive cleaning to remove reservoirs of allergen.
- Possible role for tannic acid to augment allergen removal.

If the pet is not removed:

- Install air cleaners, especially in the bedroom.
- Remove carpeting, especially in the bedroom.
- Encase mattresses and pillows.
- Wash animals (not likely to help unless done at least twice a week).
- These measures may not reduce allergen levels enough to help highly allergic patients.

Once a cat has been removed from the home, it is important to recognize that the clinical benefit may not be seen for a period of at least several months because allergen levels fall quite slowly after cat removal.<sup>76</sup> In most homes, levels of settled dust will have fallen to those seen in homes without cats within 4 to 6 months of cat removal. Levels may fall much more quickly if extensive environmental control measures are undertaken, such as removal of carpets, upholstered furniture and other reservoirs from the home, whereas in other homes the process may be considerably slower. This information points to the fact that thorough and repeated cleaning will be required once the animal has been removed. It has also been shown that cat allergen may persist in mattresses for years after a cat has been removed from a home,<sup>84</sup> so new bedding or impermeable encasements must therefore also be recommended.

A number of studies have investigated other measures that might help to reduce cat allergen exposure without removing the animal from the home. De Blay and colleagues<sup>85</sup> demonstrated significant reductions in airborne Fel d 1 with a combination of air filtration, cat washing, vacuum cleaning and removal of furnishings, although these results were based on a small sample size and did not include any measure of clinical effect. When cat washing was evaluated separately in that study, dramatic reductions in airborne Fel d 1 were seen afterward. Subsequent studies, however, have presented conflicting results. Klucka and colleagues<sup>86</sup> studied both cat washing and Allerpet/c (Allerpet, Inc., New York, New York) and found no benefit from either treatment. In addition, Avner and colleagues<sup>87</sup> studied three different methods of cat washing and found transient reductions in airborne cat allergens after each. There was no sustained benefit, however, with levels returning to baseline within 1 week of washing. Results regarding dog allergen are very similar to those with cat, suggesting the need to wash dogs at least twice a week to achieve any meaningful reduction in allergen exposure.<sup>88</sup>

Information is very limited as to the clinical benefits of these environmental control measures if one or more pets is allowed to remain in the home. Studies have evaluated different combinations of control measures, and although all have shown reductions in allergen levels, clinical effect was less consistent.<sup>89–92</sup> Two studies showed a clear benefit, one showed benefit only in the group in which environmental control was performed along with intranasal steroid treatment, and the fourth showed no clinical benefit whatsoever. It therefore still remains to be seen

whether allergen exposure can be sufficiently reduced to produce a clinical effect in the absence of animal removal.

While the notion of hypoallergenic cats and dogs is increasingly popular, there are no studies confirming that any specific breeds are predictably less allergenic. Further, there is no evidence that the size, hair length, hair type or degree of shedding have any effects on indoor allergen levels or allergenicity.<sup>4,93</sup>

In families who insist on keeping their pets, the following should be recommended pending more definitive studies.<sup>4</sup> The animals should be restricted to one area of the home and certainly kept out of the patient's bedroom. HEPA or electrostatic air cleaners should be used, especially in the patient's bedroom. Carpets and other reservoirs for allergen collection should be removed whenever possible, again focussing on the patient's bedroom. Finally, mattress and pillow covers should be routinely used. Although tannic acid has been shown to reduce cat allergen levels, the effects are modest and short-lived when a cat is present, so this treatment should not be routinely recommended. Similarly, cat and dog washing appears to be of such transient benefit that it is only likely to add significantly to the other avoidance measures if it is done at least twice a week.

## Cockroach Allergen

The importance of cockroach allergen in asthma and allergy has been recognized only over the past 30 years.<sup>94,95</sup> It is now clear that cockroach allergens play a major role in asthma, particularly in urban areas.<sup>2,96</sup> Significant cockroach exposure has been demonstrated in a number of cities, and the prevalence of cockroach sensitivity in urban patients with asthma has been shown to range from 23% to 60%.<sup>15,97,98</sup> In addition, cockroach exposure has been associated with higher rates of sensitization.<sup>99</sup> The combination of cockroach exposure and cockroach sensitization has been shown to be a risk factor for increased asthma morbidity and acute asthma exacerbations.<sup>15,33,74</sup>

In the first comprehensive study on the problem of asthma in inner city children, 1,528 children with asthma from eight major inner city areas were extensively investigated with regard to the factors, both allergic and otherwise, that contributed to their disease.<sup>74</sup> Although sensitivity to cockroaches, dust mites and cats were all common (36.8%, 36.9% and 22.7%, respectively), exposure to cockroach allergen was much more common than exposure to either dust mite or cat (50.2%, 9.7% and 12.8%, respectively). The combination of cockroach sensitivity and high cockroach exposure was associated with significantly more hospitalizations, unscheduled medical visits for asthma, days of wheezing, missed days from school, and nights with sleep loss because of asthma. Such a correlation was not seen for dust mite or cat allergens. These data argue persuasively that cockroach allergen is a major factor, if not *the* major factor, in the high degree of morbidity seen in this patient population.

Although there are at least 50 cockroach species in the USA, only four or five are domiciliary.<sup>2,96</sup> Two species, the German cockroach (*Blattella germanica*) and the American cockroach (*Periplaneta americana*), are the most common causes of both household infestation and allergic sensitization. Several allergens from each species have been identified and characterized.<sup>100,101</sup> The most important among these are Bla g 1, Bla g 2 and Per a 1. There is significant cross-reactivity between *B. germanica* and *P. americana*, although most patients in the USA are primarily sensitized to *B. germanica*. The source of the major cockroach allergen is still not completely clear, although

they do appear to be secreted or excreted, suggesting that they may also be digestive proteins.

The distribution of cockroach allergens has been studied in a number of settings. The highest levels tend to be found in kitchens, although the allergen is widely distributed through the home, including the bedroom.<sup>2,74,101</sup> In fact, in the inner city asthma study noted above, the 50.2% exposure rate was found in bedroom dust samples.<sup>74</sup> It has been suggested that cockroach allergen levels of greater than 2 units per gram are associated with sensitization and levels greater than 8 units per gram are associated with disease activity.<sup>74</sup> Cockroach allergen has also been detected at significant concentrations in schools in urban Baltimore.<sup>102</sup> Finally, studies have shown that cockroach allergen is very much like dust mite allergen, with little or no measurable airborne allergen in the absence of significant disturbance.<sup>96</sup>

### COCKROACH ALLERGEN CONTROL

Extensive study has been performed on the chemical control of cockroach infestation, and a variety of pesticides and traps are readily available. These include chlorpyrifos, diazinon, boric acid powder and bait stations that contain hydramethylnon. All of these agents, with the exception of boric acid, can reduce cockroach numbers by 90% or more, whereas boric acid reduces numbers by 40% to 50%. Several studies have shown that cockroach extermination is possible in most homes and that a combination of extermination and thorough cleaning can reduce cockroach allergen levels by 80% to 90%,<sup>103–105</sup> although studies to date have not convincingly demonstrated that cockroach eradication alone is capable of significantly reducing disease activity.<sup>106–108</sup>

In addition to these measures, integrated pest management also includes other strategies that help to reduce cockroach infestation including eliminating food sources and hiding and entry points (Box 22-3).<sup>2,109</sup> All foods should be stored in sealed containers and the kitchen should be cleaned regularly. Finally, extensive cleaning should be performed after extermination to remove the cockroach debris as completely as possible. Even with the most aggressive measures, however, it may be difficult to reduce cockroach exposure adequately in some environments. This is particularly true of the older, multiple dwelling units that house a preponderance of inner city residents. A more encouraging study related to inner city asthma did demonstrate a convincing benefit from a multifaceted, allergen-specific environmental control program in asthmatic children living in urban areas.<sup>5</sup> In that study, cockroach extermination was part

#### BOX 22-3 ENVIRONMENTAL CONTROL OF COCKROACH ALLERGEN

- Regular and thorough extermination
- Thorough cleaning after extermination
- Extermination of neighboring dwellings
- Roach traps
- Repair leaky faucets and pipes
- Repair holes in walls and other entry points
- Behavioral changes to reduce food sources
  - Clean immediately after cooking
  - Clean dirty dishes immediately
  - Avoid open food containers
  - Avoid uncovered trash cans

of a global environmental treatment that also included education, a HEPA filtered vacuum cleaner, allergen-proof bedding encasings and a HEPA filter in the child's bedroom. Bla g 1 in floor dust was reduced by 53% compared to 19% in the control group but, more importantly, symptoms were also significantly reduced in the treated group. This trial supports the concept that integrated environmental avoidance strategies have the highest likelihood of producing beneficial clinical effects.

### Rodent Allergens

Mice and rats produce allergens, primarily urinary proteins, that have been shown to cause sensitization and disease in both occupational and home environments.<sup>3</sup> The widespread distribution of mouse allergen in home environments and its potential importance in asthma, especially in those living in inner cities, has recently been demonstrated in a number of studies.<sup>110–116</sup> In fact, mouse allergens are measurable in nearly all inner city homes and as many as 75% of suburban homes.<sup>117–119</sup> However, the levels in inner city homes are far higher, in fact 100 to 1,000-fold higher, in comparison to suburban homes.<sup>120</sup> With regard to effects on disease, mouse exposure has been associated with increased sensitization, poorer asthma control and increased healthcare utilization.<sup>3,111–116</sup> Even in adults, sensitization to mouse allergens has been shown to be associated with asthma and asthma morbidity.<sup>121</sup>

Although there are a number of ongoing trials, to date relatively little has been published on the effectiveness of environmental control for mouse allergen. Phipatanakul and colleagues did demonstrate a >75% reduction in mouse allergen exposure using an integrated pest management strategy that included filling holes with copper mesh, vacuuming, cleaning and baiting of traps with low-toxicity pesticides.<sup>122</sup> In another study, an integrated pest management intervention that was performed by study participants had less overall success because mouse allergen levels were only reduced by approximately 27%.<sup>123</sup> However, the subset of children whose homes had at least a 50% reduction in mouse allergen had fewer missed school days, reduced sleep disruption and reduced caretaker burden.

Based on these studies and general information about pest management, recommendations for mouse allergen control include professional extermination, thorough cleaning after extermination, keeping food and trash in covered containers, cleaning food scraps from the floor and countertops, and sealing cracks in the walls, doors and floors (Box 22-4).<sup>3</sup>

### Mold Allergens

A wide variety of mold species can be present in both indoor and outdoor environments. *Aspergillus* and *Penicillium* species are generally regarded as the most numerous indoor molds,<sup>60,101</sup> whereas *Alternaria* is important in both indoor and outdoor environments. Several mold allergens, including Alt n 1 and Asp

#### BOX 22-4 ENVIRONMENTAL CONTROL OF RODENT ALLERGENS

- Regular and thorough extermination
- Thorough cleaning after extermination
- Keep food and trash in covered containers
- Seal cracks in walls, door and floors

f 1, have been identified and characterized. Mold exposure has been associated with chronic asthma symptoms as well as with asthma exacerbations.<sup>124–126</sup>

Molds tend to grow best in warm, moist environments and mold exposure is therefore roughly correlated with these conditions. Basements, window sills, shower stalls and bathroom carpets are common sites of mold infestation. Air conditioners and humidifiers have also been shown to be sources of significant mold exposure.<sup>127,128</sup> The assessment of mold exposure has been improved by the development of immunoassays to measure major allergens, although for most molds one must still rely on culture and microscopic examination of air or dust samples. Airborne mold allergens have been shown to be carried on particles ranging in size from less than 2  $\mu\text{m}$  to greater than 100  $\mu\text{m}$ .<sup>129</sup>

The control of mold allergens requires a concerted approach combining fungicides, measures to reduce humidity and the removal of mold-infested items whenever possible<sup>124</sup> (Box 22-5). With more severe infestation, such as after flooding has occurred, professional remediation may be required. A variety of fungicides are commercially available that are highly effective as long as the sites of mold growth are carefully investigated. Any measures that can then be taken to reduce humidity should be recommended, including dehumidification, air conditioning, increased ventilation and a ban on the use of humidifiers and vaporizers. Moldy items, such as a basement carpet that has suffered water damage, should be removed altogether. Although no specific data are available, air filtration devices may also assist in reducing mold exposure; no clinical studies on the efficacy of mold avoidance measures have been undertaken.

## Indoor Air Pollution

Although a detailed discussion of indoor air pollution is beyond the scope of this chapter, it should be emphasized that effective environmental control cannot be achieved without attention to a variety nonspecific irritants. The deleterious effects of passive cigarette smoke on pediatric asthma have been well documented in a number of studies.<sup>130,131</sup> No studies to date have assessed the clinical benefit of removal from a smoke-containing environment, but one would predict that this would have highly beneficial effects. In addition to passive cigarette smoke, a variety of other indoor pollutants, such as nitrous oxide, have been documented to exacerbate pediatric asthma, especially in inner city environments.<sup>132,133</sup> All patients must therefore be queried about these exposures and counseled about their control. Parents who are smokers and who have asthmatic children need to be reminded at each visit about the ongoing damage that they are causing.

### BOX 22-5 ENVIRONMENTAL CONTROL OF MOLD ALLERGENS

- Identify sites/sources of mold growth
- Clean moldy areas with a fungicide
- If cleaning is not possible, discard moldy items (e.g. carpets, furniture)
- Dehumidify
- Repair leaks and maximize drainage
- Run vent in bathroom and kitchen
- Clean refrigerator, dehumidifier and humidifier with fungicide

## Outdoor Allergens

There is far less ability to control exposure to outdoor allergens than indoor allergens. Source control is rarely an option because the airborne pollens and molds travel so widely. Local mold control may be accomplished by ensuring good drainage, removing leaves and other debris as they accumulate, and limiting the use of mulch and other ground cover that might support mold growth. Otherwise, exposure may be reduced by staying indoors when pollen and mold counts are high, as long as windows and doors are kept closed. An air filter may help to reduce exposure, especially if windows are being left open; some activities, such as lawn mowing or plowing, may need to be avoided altogether. After being outside, it is important that allergic individuals wash their hands and faces immediately and that they wash their hair daily. When outside, masks and goggles can be very effective but very few children and adolescents are willing to wear them.

## Conclusions

Indoor allergens are of tremendous importance to pediatric allergic disease. Exposure is a risk factor for the development of asthma as well as for more severe disease. Thankfully, there are measures that can help to reduce exposure to most allergens, significantly reducing symptoms and medication requirements. The guidelines for the management of asthma that were originally published in 1997 and most recently revised in 2007<sup>134</sup> have consistently stressed the importance of indoor allergens and environmental control, stating that for any patient with persistent asthma the clinician should: (1) identify allergen exposures; (2) use skin testing or in vitro testing to assess specific sensitivities to indoor allergens; and (3) implement environmental controls to reduce exposure to relevant allergens. With all the time, effort and money put forth for the use of medications and immunotherapy for asthma and allergic rhinitis, it is very important that we do not lose sight of this logical and important recommendation.

## Helpful Websites

- Allergy & Asthma Network Mothers of Asthmatics ([www.aanma.org](http://www.aanma.org))
- The American Academy of Allergy Asthma & Immunology website ([www.aaaai.org/](http://www.aaaai.org/))
- The American College of Allergy, Asthma and Immunology website ([www.acaai.org/](http://www.acaai.org/))
- American Lung Association ([www.lung.org](http://www.lung.org))
- Association of Asthma Educators ([www.asthmaeducators.org](http://www.asthmaeducators.org))
- Asthma and Allergy Foundation of America ([www.aafa.org](http://www.aafa.org))
- Centers for Disease Control and Prevention ([www.cdc.gov](http://www.cdc.gov))
- National Heart, Lung, and Blood Institute Information Center ([www.nhlbi.nih.gov](http://www.nhlbi.nih.gov))
- National Institute of Allergy and Infectious Diseases ([www.niaid.nih.gov](http://www.niaid.nih.gov))
- US Environmental Protection Agency National Center for Environmental Publications ([www.airnow.gov](http://www.airnow.gov))

The complete reference list can be found on the companion Expert Consult website at <http://www.expertconsult.inkling.com>.

## KEY REFERENCES

1. Portnoy J, Miller JD, Williams PB, Chew GL, Miller JD, Zaitoun F, et al. Environmental assessment and exposure control of dust mites: a practice parameter. *Ann Allergy Asthma Immunol* 2013;111:465–507.
2. Portnoy J, Chew GL, Phipatanakul W, Williams PB, Grimes C, Kennedy K, et al. Environmental assessment and exposure reduction of cockroaches: a practice parameter. *J Allergy Clin Immunol* 2013;132:802–8.
3. Phipatanakul W, Matsui E, Portnoy J, Williams PB, Barnes C, Kennedy K, et al. Environmental assessment and exposure reduction of rodents: a practice parameter. *Ann Allergy Asthma Immunol* 2012;109:375–87.
4. Portnoy J, Kennedy K, Sublett J, Phipatanakul W, Matsui E, Barnes C, et al. Environmental assessment and exposure control: a practice parameter – furry animals. *Ann Allergy Asthma Immunol* 2012;108:223, e1–15.
5. Morgan WJ, Crain EF, Gruchalla RS, O'Connor GT, Kattan M, Evans R 3rd, et al. Results of a home-based environmental intervention among urban children with asthma. *N Engl J Med* 2004;351:1068–73.
14. Sporik R, Holgate ST, Platts-Mills TAE, Cogswell JJ. Exposure to house-dust mite allergen (Der p I) and the development of asthma in childhood: a prospective study. *N Engl J Med* 1990;323:502–7.
34. Platts-Mills TAE, Tovey ER, Mitchell EB, Moszoro H, Nock P, Wilkins SR. Reduction of bronchial hyperreactivity following prolonged allergen avoidance. *Lancet* 1982;2:675–8.
47. Woodcock A, Forster L, Matthews E, Martin J, Letley L, Vickers M, et al. Control of exposure to mite allergen and allergen-impermeable bed covers for adults with asthma. *N Engl J Med* 2003;349:225–30.
74. Rosenstreich DL, Eggleston P, Kattan M, Baker D, Slavin RG, Gergen P, et al. The role of cockroach allergy and exposure to cockroach allergen in causing morbidity among inner-city children with asthma. *N Engl J Med* 1997;336:1356–63.
109. Sheehan WJ, Rangsithienchai PA, Wood RA, Rivard D, Chinratanapisit S, Perzanowski MS, et al. Pest and allergen exposure and abatement in inner-city asthma: a work group report of the American Academy of Allergy, Asthma & Immunology Indoor Allergy/Air Pollution Committee. *J Allergy Clin Immunol* 2010;125:575–81.



## REFERENCES

- Portnoy J, Miller JD, Williams PB, Chew GL, Miller JD, Zaitoun F, et al. Environmental assessment and exposure control of dust mites: a practice parameter. *Ann Allergy Asthma Immunol* 2013;111:465–507.
- Portnoy J, Chew GL, Phipatanakul W, Williams PB, Grimes C, Kennedy K, et al. Environmental assessment and exposure reduction of cockroaches: a practice parameter. *J Allergy Clin Immunol* 2013;132:802–8.
- Phipatanakul W, Matsui E, Portnoy J, Williams PB, Barnes C, Kennedy K, et al. Environmental assessment and exposure reduction of rodents: a practice parameter. *Ann Allergy Asthma Immunol* 2012;109:375–87.
- Portnoy J, Kennedy K, Sublett J, Phipatanakul W, Matsui E, Barnes C, et al. Environmental assessment and exposure control: a practice parameter – furry animals. *Ann Allergy Asthma Immunol* 2012;108:223, e1–15.
- Morgan WJ, Crain EF, Gruchalla RS, O'Connor GT, Kattan M, Evans R 3rd, et al. Results of a home-based environmental intervention among urban children with asthma. *N Engl J Med* 2004;351:1068–73.
- van Schayck OC, Maas T, Kaper J, Knottnerus AJ, Sheikh A. Is there any role for allergen avoidance in the primary prevention of childhood asthma? *J Allergy Clin Immunol* 2007;119:1323–30.
- Platts-Mills TAE, De Weck A. Dust mite allergens and asthma – a worldwide problem. *Bull WHO* 1989;66:769–80.
- Platts-Mills TAE, Thomas WR, Aalberse RC, Vervloet D, Chapman MD. Dust mite allergens and asthma: report of a second international workshop. *J Allergy Clin Immunol* 1992;89:1046–60.
- Arlian LG, Platts-Mills TAE. The biology of dust mites and the remediation of mite allergens in allergic disease. *J Allergy Clin Immunol* 2001;107:S406–13.
- Arlian LG. Biology and ecology of house dust mites *Dermatophagoides* spp. and *Euroglyphus* spp. *Immunol Allergy Clin North Am* 1989;9:339–56.
- Kueher J, Frischer J, Meiner R, Barth R, Forster J, Schraub S, et al. Mite exposure is a risk factor for the incidence of specific sensitization. *J Allergy Clin Immunol* 1994;94:44–52.
- Lau S, Falkenhorst G, Weber A, Werthmann I, Lind P, Buettner-Goetz P, et al. High mite-allergen exposure increases the risk of sensitization in atopic children and young adults. *J Allergy Clin Immunol* 1989;84:718–25.
- Peat JK, Tovey E, Mellis CM, Leeder SR, Woolcock AJ. Importance of house dust mite and *Alternaria* allergens in childhood asthma: an epidemiological study in two climatic regions of Australia. *Clin Exp Allergy* 1993;23:812–20.
- Sporik R, Holgate ST, Platts-Mills TAE, Cogswell JJ. Exposure to house-dust mite allergen (Der p I) and the development of asthma in childhood: a prospective study. *N Engl J Med* 1990;323:502–7.
- Call RS, Smith TF, Morris E, Chapman MD, Platts-Mills TA. Risk factors for asthma in inner-city children. *J Pediatr* 1992;121:862–6.
- Platts-Mills TAE, Heymann PW, Longbottom JL, Wilkins SR. Airborne allergens associated with asthma: particle sizes carrying dust mite and rat allergens measured with a cascade impactor. *J Allergy Clin Immunol* 1986;77:850–7.
- Dowse GK, Turner KJ, Stewart GA, Alpers MP, Woolcock AJ. The association between Dermatophagoides mites and the increasing prevalence of asthma in village communities within the Papua New Guinea highlands. *J Allergy Clin Immunol* 1985;75:75–83.
- Ingram JM, Sporik R, Rose G, Honsinger R, Chapman MD, Platts-Mills TA. Quantitative assessment of exposure to dog (Can f 1) and cat (Fel d 1) allergens: relationship to sensitization and asthma among children living in Los Alamos, New Mexico. *J Allergy Clin Immunol* 1995;96:449–56.
- Burrows B, Sears MR, Flannery EM, Herbison GP, Holdaway MD. Relations of bronchial responsiveness to allergy skin test reactivity, lung function, respiratory symptoms and diagnoses in thirteen-year-old New Zealand children. *J Allergy Clin Immunol* 1995;95:548–56.
- Peat JK, Tovey ER, Toelle BG, Haby MM, Gray EJ, Mahmic A, et al. House-dust mite allergens: a major risk factor for childhood asthma in Australia. *Am J Respir Crit Care Med* 1996;153:141–6.
- Sears MR, Herbison GP, Holdaway MD, Hewitt CJ, Flannery EM, Silva PA. The relative risk of sensitivity to grass pollen, house dust mite, and cat dander in the development of childhood asthma. *Clin Exp Allergy* 1989;19:419–24.
- Hide DW, Matthews S, Tariq S, Arshad SH. Allergen avoidance in infancy and allergy at 4 years of age. *Allergy* 1996;51:89–93.
- Marinho S, Simpson A, Custovic A. Allergen avoidance in the secondary and tertiary prevention of allergic diseases: does it work? *Prim Care Respir J* 2006;15:152–8.
- Arshad SH, Bateman B, Sadeghnejad A, Gant C, Matthews SM. Prevention of allergic disease during childhood by allergen avoidance: the Isle of Wight prevention study. *J Allergy Clin Immunol* 2007;119:307–13.
- Becker A, Watson W, Ferguson A, Dimich-Ward H, Chan-Yeung M. The Canadian asthma primary prevention study: outcomes at 2 years of age. *J Allergy Clin Immunol* 2004;113:650–6.
- Chan-Yeung M, Ferguson A, Watson W, Dimich-Ward H, Rousseau R, Lilley M, et al. The Canadian Childhood Asthma Primary Prevention Study: outcomes at 7 years of age. *J Allergy Clin Immunol* 2005;116:49–55.
- Corver K, Kerkhof M, Brussee JE, Brunekreef B, van Strien RT, Vos AP, et al. House dust mite allergen reduction and allergy at 4 yr: follow up of the PIAMA-study. *Pediatr Allergy Immunol* 2006;17:329–36.
- Custovic A, Simpson BM, Simpson A, Kissen P, Woodcock A, Manchester NAC. Asthma and Allergy Study Group. Effect of environmental manipulation in pregnancy and early life on respiratory symptoms and atopy during first year of life: a randomised trial. *Lancet* 2001;358:188–93.
- Maas T, Kaper J, Sheikh A, Knottnerus JA, Weseling G, Dompeling E, et al. Mono and multifaceted inhalant and/or food allergen reduction interventions for preventing asthma in children at high risk of developing asthma. *Cochrane Database Syst Rev* 2009;3:CD006480.
- Custovic A, Taggart SCO, Francis HC, Chapman MD, Woodcock A. Exposure to house dust mite allergens and the clinical activity of asthma. *J Allergy Clin Immunol* 1996;98:64–72.
- Kivity S, Solomon A, Soferman R, Schwarz Y, Mumcuoglu KY, Topilsky M. Mite asthma in childhood: a study of the relationship between exposure to house dust mites and disease activity. *J Allergy Clin Immunol* 1993;91:844–9.
- Vervloet D, Charpin D, Haddi E, N'guyen A, Birnbaum J, Soler M, et al. Medication requirements and house dust mite exposure in mite-sensitive asthmatics. *Allergy* 1991;46:554–8.
- Pollart SM, Chapman MD, Fiocco GP, Rose G, Platts-Mills TA. Epidemiology of acute asthma: IgE antibodies to common inhalant allergens as a risk factor for emergency room visits. *J Allergy Clin Immunol* 1989;83:875–82.
- Platts-Mills TAE, Tovey ER, Mitchell EB, Moszoro H, Nock P, Wilkins SR. Reduction of bronchial hyperreactivity following prolonged allergen avoidance. *Lancet* 1982;2:675–8.
- Murray AB, Ferguson AC. Dust-free bedrooms in the treatment of asthmatic children with house dust or house dust mite allergy. *Pediatrics* 1983;71:418–22.
- Carswell F, Birmingham K, Oliver J, Crewes A, Weeks J. The respiratory effects of reduction of mite allergen in bedrooms of asthmatic children: a double-blind controlled trial. *Clin Exp Allergy* 1996;26:386–96.
- Dietemann A, Bessot JC, Hoyet C, Ott M, Verot A, Pauli G. A double-blind, placebo-controlled trial of solidified benzyl benzoate applied in dwellings of asthmatic patients sensitive to mites: clinical efficacy and effect on mite allergens. *J Allergy Clin Immunol* 1993;91:738–46.
- Ehnert B, Lau-Schadendorf S, Weber A, Buettner P, Schou C, Wahn U. Reducing domestic exposure to dust mite allergen reduces bronchial hyperreactivity in sensitive children with asthma. *J Allergy Clin Immunol* 1992;90:135–8.
- Gillies DRN, Littlewood JM, Sarsfield JK. Controlled trial of house dust mite avoidance in children with mild to moderate asthma. *Clin Allergy* 1987;17:105–11.
- Peroni DG, Boner AL, Vallone G, Antolini I, Warner JO. Effective allergen avoidance at high-altitude reduced allergen-induced bronchial hyperresponsiveness. *Am J Resp Crit Care Med* 1994;149:1442–6.
- de Vries MP, van den Bemt L, Aretz K, Thoonen BP, Muris JW, Kester AD, et al. House dust mite allergen avoidance and self-management in allergic patients with asthma: randomised controlled trial. *Br J Gen Pract* 2007;57:184–9.
- Gotzsche PC, Hammarquist C, Burr M. House dust mite control measures in the management of asthma: meta-analysis. *BMJ* 1998;317:1105–10.
- Nurmatov U, van Schayck CP, Hurwitz B, Sheikh A. House dust mite avoidance measures for perennial allergic rhinitis: an updated Cochrane Systematic Review. *Allergy* 2012;67:158–65.
- Sheikh A, Hurwitz B, Nurmatov U, van Schayck CP. House dust mite avoidance measures for perennial allergic rhinitis. *Cochrane Database Syst Rev* 2010;7:CD001563.
- Gotzsche PC, Johansen HK. House dust mite control measures for asthma. *Cochrane Database Syst Rev* 2008;2:CD001187.
- Platts-Mills TA. Allergen avoidance in the treatment of asthma: problems with the meta-analyses. *J Allergy Clin Immunol* 2008;122:694–6.

47. Woodcock A, Forster L, Matthews E, Martin J, Letley L, Vickers M, et al. Control of exposure to mite allergen and allergen-impermeable bed covers for adults with asthma. *N Engl J Med* 2003;349:225–30.
48. Terreehorst I, Hak E, Oosting AJ, Tempels-Pavlica Z, de Monchy JG, Bruijnzeel-Koomen CA, et al. Evaluation of impermeable covers for bedding in patients with allergic rhinitis. *N Engl J Med* 2003;349:237–41.
49. Owen S, Morganstern M, Hepworth J, Woodcock A. Control of house dust mite antigen in bedding. *Lancet* 1990;335:396–7.
50. Tovey E, Marks G, Shearer M, Woolcock A. Allergens and occlusive bed covers. *Lancet* 1993;342:126.
51. Miller JD, Naccara L, Satinover S, Platts-Mills TA. Nonwoven in contrast to woven mattress encasings accumulate mite and cat allergen. *J Allergy Clin Immunol* 2007;120:977–82.
52. Kalra S, Owen SJ, Hepworth J, Woodcock A. Airborne house dust mite antigen after vacuum cleaning. *Lancet* 1990;336:449.
53. de Bohr R. The control of house dust mite allergens in rugs. *J Allergy Clin Immunol* 1990;86:808–14.
54. Htut T, Higenbottam TW, Gill GW, Darwin R, Anderson PB, Syed N. Eradication of house dust mite from homes of atopic asthmatic subjects: a double-blind trial. *J Allergy Clin Immunol* 2001;107:55–60.
55. Wassenaar DP. Effectiveness of vacuum cleaning and wet cleaning in reducing house-dust mites, fungi and mite allergen in a cotton carpet: a case study. *Exp Appl Acarol* 1988;4:53–62.
56. Lau-Schadendorf S, Rusche AF, Weber AK, Buettner-Goetz P, Wahn U. Short-term effect of solidified benzyl benzoate on mite-allergen concentrations in house dust. *J Allergy Clin Immunol* 1991;87:41–7.
57. Woodfolk JA, Hayden ML, Couture N, Platts-Mills TAE. Chemical treatment of carpets to remove allergen. *J Allergy Clin Immunol* 1996;96:325–33.
58. Woodfolk J, Hayden M, Miller J, Rose G, Chapman MD, Platts-Mills TA. Chemical treatment of carpets to reduce allergen: a detailed study of the effects of tannic acid on indoor allergens. *J Allergy Clin Immunol* 1994;94:19–26.
59. McDonald LG, Tovey ER. The role of water temperature and laundry procedures in reducing house dust mite populations and allergen content of bedding. *J Allergy Clin Immunol* 1992;90:599–608.
60. Vendenhove T, Soler M, Birnbaum J, Charpin D, Vervloet D. Effect of dry cleaning on the mite allergen levels in blankets. *Allergy* 1993;48:264–6.
61. Dodin A, Rak H. Influence of low temperature on the different stages of the human allergy mite *Dermatophagoides pteronyssinus*. *J Med Entomol* 1993;30:810–11.
62. Tovey E, Woolcock A. Direct exposure of carpets to sunlight can kill all mites. *J Allergy Clin Immunol* 1993;93:1072–4.
63. Mosbech H, Korsgaard J, Lind P. Control of house dust mites by electrical heating blankets. *J Allergy Clin Immunol* 1988;81:706–10.
64. Korsgaard J, Iversen M. Epidemiology of house dust mite allergy. *Allergy* 1991;46:14–18.
65. Arlian LG, Neal JS, Vyzenski-Moher HL. Reducing humidity to control the house dust mite *Dermatophagoides farinae*. *J Allergy Clin Immunol* 1999;104:852–6.
66. Custovic A, Taggart S, Kennaugh J, Woodcock A. Portable dehumidifiers in the control of house dust mites and mite allergens. *Clin Exp Allergy* 1995;25:312–16.
67. Antonicelli L, Bilo MB, Pucci S, Schou C, Bonifazi F. Efficacy of an air-cleaning device equipped with a high-efficiency particulate air filter in house dust mite respiratory allergy. *Allergy* 1991;46:594–600.
68. Nelson HS, Hirsch SR, Ohman JL Jr, Platts-Mills TA, Reed CE, Solomon WR. Recommendations for the use of residential air-cleaning devices in the treatment of respiratory diseases. *J Allergy Clin Immunol* 1988;82:661–9.
69. Reisman RE, Mauriello PM, Davis GB, Georgitis JW, DeMasi JM. A double-blind study of the effectiveness of a high-efficiency particulate air (HEPA) filter in the treatment of patients with perennial allergic rhinitis and asthma. *J Allergy Clin Immunol* 1990;85:1050–9.
70. Warner JA, Marchant JL, Warner JO. Double-blind trial of ionisers in children with asthma sensitive to the house dust mite. *Thorax* 1993;48:330–3.
71. Chapman MD, Wood RA. The role and remediation of animal allergens in allergic diseases. *J Allergy Clin Immunol* 2001;107:S414–21.
72. Sporik R, Ingram JM, Price W, Sussman JH, Honsinger RW, Platts-Mills TA. Association of asthma with serum IgE and skin test reactivity to allergens among children living at high altitude: tickling the dragon's breath. *Am J Respir Crit Care Med* 1995;151:1388–92.
73. Munir AKM, Bjorksten B, Einarsson R, Schou C, Ekstrand-Tobin A, Warner A, et al. Cat (Fel d 1), dog (Can f 1) and cockroach allergens in homes of asthmatic children from three climatic zones in Sweden. *Allergy* 1994;49:508–16.
74. Rosenstreich DL, Eggleston P, Kattan M, Baker D, Slavin RG, Gergen P, et al. The role of cockroach allergy and exposure to cockroach allergen in causing morbidity among inner-city children with asthma. *N Engl J Med* 1997;336:1356–63.
75. Wood RA, Eggleston PA, Lind P, Ingemann L, Schwartz B, Graveson S, et al. Antigenic analysis of household dust samples. *Am Rev Res Dis* 1988;137:358–63.
76. Wood RA, Chapman MD, Adkinson NF Jr, Eggleston PA. The effect of cat removal on allergen content in household dust samples. *J Allergy Clin Immunol* 1989;83:730–4.
77. Wood RA, Mudd KE, Eggleston PA. The distribution of cat and dust mite allergens on wall surfaces. *J Allergy Clin Immunol* 1992;89:126–30.
78. Wood RA, Laheri AN, Eggleston PA. The aerodynamic characteristics of cat allergen. *Clin Exp Allergy* 1993;23:733–9.
79. Luczynska CM, Li Y, Chapman MD, Platts-Mills TA. Airborne concentrations and particle size distribution of allergen derived from domestic cats (*Felis domesticus*). *Am Rev Respir Dis* 1990;141:361–7.
80. Custovic A, Green R, Fletcher A, Smith A, Pickering CA, Chapman MD, et al. Aerodynamic properties of the major dog allergen Can f 1: distribution in homes, concentration, and particle size of allergen in the air. *Am J Respir Crit Care Med* 1997;155:94–8.
81. Bollinger ME, Eggleston PA, Wood RA. Cat antigen in homes with and without cats may induce allergic symptoms. *J Allergy Clin Immunol* 1996;97:907–14.
82. Kilburn S, Lasserson TJ, McKean M. Pet allergen control measures for allergic asthma in children and adults. *Cochrane Database Syst Rev* 2003;1:CD002989.
83. Shirai T, Matsui T, Suzuki K, Chida K. Effect of pet removal on pet allergic asthma. *Chest* 2005;127:1565–71.
84. Van der Brempt X, Charpin D, Haddi E, da Mata P, Vervloet D. Cat removal and Fel d 1 levels in mattresses. *J Allergy Clin Immunol* 1991;87:595–6.
85. De Blay F, Chapman MD, Platts-Mills TAE. Airborne cat allergen (Fel d 1): environmental control with the cat in situ. *Am Rev Respir Dis* 1991;143:1334–9.
86. Klucka CV, Ownby DR, Green J, Zoratti E. Cat shedding of Fel d 1 is not reduced by washings, Allerpet-C spray, or acepromazine. *J Allergy Clin Immunol* 1995;95:1164–71.
87. Avner DB, Perzanowski MS, Platts-Mills TAE, Woodfolk JA. Evaluation of different techniques for washing cats: quantitation of allergen removed from the cat and effect on airborne Fel d 1. *J Allergy Clin Immunol* 1997;100:357–62.
88. Hodson T, Custovic A, Simpson A, Chapman M, Woodcock A, Green R. Washing the dog reduces dog allergen levels, but the dog needs to be washed twice a week. *J Allergy Clin Immunol* 1999;103:581–5.
89. Bjornsdottir US, Jakobinudottir S, Runarsdottir V, et al. Environmental control with cat in situ reduces cat allergen in house dust samples but does it alter clinical symptoms? *J Allergy Clin Immunol* 1997;99:S389.
90. Soldatov D, De Blay F, Greiss P, et al. Effects of environmental control measures on patient status and airborne Fel d 1 levels with a cat in situ. *J Allergy Clin Immunol* 1995;95:263.
91. Wood RA, Johnson EF, Van Natta ML, Chen PH, Eggleston PA. A placebo-controlled trial of a HEPA air cleaner in the treatment of cat allergy. *Am J Respir Crit Care Med* 1998;158:115–20.
92. Van der Heide S, van Aalderen WMC, Kaufmann HF, Dubois AE, de Monchy JG. Clinical effects of air cleaners in homes of allergic children sensitized to pet allergens. *J Allergy Clin Immunol* 1999;104:447–51.
93. Nicholas C, Wegienka G, Havstad S, Zoratti E, Ownby D, Johnson C. Dog allergen levels in homes with hypoallergenic compared with nonhypoallergenic dogs. *Am J Rhinol Allergy* 2011;25:252–6.
94. Benton H, Brown H. Insect allergy—preliminary studies of the cockroach. *J Allergy* 1964;35:506–13.
95. Kang B, Vellody D, Homburger H, Yunginger JW. Cockroach as a cause of allergic asthma. Its specificity and immunologic profile. *J Allergy Clin Immunol* 1979;63:80–6.
96. Eggleston PA, Arruda LK. Ecology and elimination of cockroaches and allergens in the home. *J Allergy Clin Immunol* 2001;107:S422–9.
97. Kang BC, Johnson J, Veres-Thorner C. Atopic profile of inner-city asthma with a comparative analysis on the cockroach-sensitive and ragweed-sensitive subgroups. *J Allergy Clin Immunol* 1993;92:802–11.
98. Sarpong SB, Hamilton RG, Eggleston PA, Adkinson NF Jr. Socioeconomic status and race as risk factors for cockroach allergen exposure and sensitization in children with asthma. *J Allergy Clin Immunol* 1996;97:1393–401.

99. Gruchalla RS, Pongracic J, Plaut M, Evans R 3rd, Visness CM, Walter M, et al. Inner city asthma study: relationships among sensitivity, allergen exposure and asthma morbidity. *J Allergy Clin Immunol* 2005;115:478–85.
100. Arruda LK, Vailes LD, Mann BJ, Shannon J, Fox JW, Vedvick TS, et al. Molecular cloning of a major cockroach (*Blattella germanica*) allergen, Bla g 2. *J Biol Chem* 1995;270:19563–8.
101. Pollart S, Smith TF, Morris EC, Gelber LE, Platts-Mills TA, Chapman MD. Environmental exposure to cockroach allergens: analysis with monoclonal antibody-based enzyme immunoassays. *J Allergy Clin Immunol* 1995;87:505–10.
102. Sarpong S, Wood RA, Karrison T, Eggleston PA. Cockroach allergen (Bla g 1) in school dust. *J Allergy Clin Immunol* 1997;99:486–92.
103. Sarpong SB, Wood RA, Eggleston PA. Short-term effects of extermination and cleaning on cockroach allergen Bla g 2 in settled dust. *Ann Allergy Asthma Immunol* 1996;76:257–60.
104. Eggleston PA, Wood RA, Rand C, Nixon WJ, Chen PH, Lukk P. Removal of cockroach allergen from inner-city homes. *J Allergy Clin Immunol* 1999;104:842–6.
105. Wood RA, Eggleston PA, Rand C, Nixon WJ, Kanchanaraks S. Cockroach allergen abatement with sodium hypochlorite in inner-city homes. *Ann Allergy Asthma Immunol* 2001;87:60–4.
106. Sever ML, Arbes SJ Jr, Gore JC, Santangelo RG, Vaughn B, Mitchell H, et al. Cockroach allergen reduction by cockroach control alone in low-income urban homes: a randomized control trial. *J Allergy Clin Immunol* 2007;120:849–55.
107. Gergen PJ, Mortimer KM, Eggleston PA, Rosenstreich D, Mitchell H, Ownby D, et al. Results of the National Cooperative Inner-City Asthma Study (NCICAS) environmental intervention to reduce cockroach allergen exposure in inner-city homes. *J Allergy Clin Immunol* 1999;103:501–7.
108. Carter MC, Perzanowski MS, Raymond A, Platts-Mills TA. Home intervention in the treatment of asthma among inner-city children. *J Allergy Clin Immunol* 2001;108:732–7.
109. Sheehan WJ, Rangsihienchai PA, Wood RA, Rivard D, Chinratanapisit S, Perzanowski MS, et al. Pest and allergen exposure and abatement in inner-city asthma: a work group report of the American Academy of Allergy, Asthma & Immunology Indoor Allergy/Air Pollution Committee. *J Allergy Clin Immunol* 2010;125:575–81.
110. Matsui EC, Diette GB, Krop EJ, Aalberse RC, Smith AL, Eggleston PA. Mouse allergen-specific immunoglobulin G4 and risk of mouse skin test sensitivity. *Clin Exp Allergy* 2006;36:1097–103.
111. Matsui EC. Environmental exposures and asthma morbidity in children living in urban neighborhoods. *Allergy* 2014;69:553–8.
112. Ahluwalia SK, Peng RD, Breyse PN, Diette GB, Curtin-Brosnan J, Aloe C, et al. Mouse allergen is the major allergen of public health relevance in Baltimore City. *J Allergy Clin Immunol* 2013;132:830–5.
113. Torjusen EN, Diette GB, Breyse PN, Curtin-Brosnan J, Aloe C, Matsui EC. Dose-response relationships between mouse allergen exposure and asthma morbidity among urban children and adolescents. *Indoor Air* 2013;23:268–74.
114. Phipatanakul W, Eggleston PA, Wright EC, Wood RA. Mouse allergen. II. The relationship of mouse allergen exposure to mouse sensitization and asthma morbidity in inner-city children with asthma. *J Allergy Clin Immunol* 2000;106:1075–80.
115. Matsui EC, Eggleston PA, Buckley TJ, Krishnan JA, Breyse PN, Rand CS, et al. Household mouse allergen exposure and asthma morbidity in inner-city preschool children. *Ann Allergy Asthma Immunol* 2006;97:514–18.
116. Matsui EC, Eggleston PA, Breyse PN, Diette GB. Mouse allergen-specific antibody responses in inner-city children with asthma. *J Allergy Clin Immunol* 2007;119:910–15.
117. Matsui EC, Simons E, Rand C, Butz A, Buckley TJ, Breyse P, et al. Airborne mouse allergen in the homes of inner-city children with asthma. *J Allergy Clin Immunol* 2005;115:358–63.
118. Matsui EC, Eggleston PA, Breyse P, Diette GB. Mouse allergen levels vary over time in inner-city homes. *J Allergy Clin Immunol* 2007;120:956–9.
119. Chew GL, Perzanowski MS, Miller RL, Correa JC, Hoepner LA, Jusino CM, et al. Distribution and determinants of mouse allergen exposure in low-income New York City apartments. *Environ Health Perspect* 2003;111:1348–52.
120. Simons E, Curtin-Brosnan J, Buckley T, Breyse P, Eggleston PA. Indoor environmental differences between inner city and suburban homes of children with asthma. *J Urban Health* 2007;84:577–90.
121. Phipatanakul W, Litonjua AA, Platts-Mills TA, Naccara LM, Celedón JC, Abdulkerim H, et al. Sensitization to mouse allergen and asthma and asthma morbidity among women in Boston. *J Allergy Clin Immunol* 2007;120:954–8.
122. Phipatanakul W, Cronin B, Wood RA, Eggleston PA, Shih MC, Song L, et al. Effect of environmental intervention on mouse allergen levels in homes of inner-city Boston children with asthma. *Ann Allergy Asthma Immunol* 2004;92:420–4.
123. Pongracic JA, Visness CM, Gruchalla RS, Evans R III, Mitchell HE. Effect of mouse allergen and rodent environmental intervention on asthma in inner-city children. *Ann Allergy Asthma Immunol* 2008;101:35e41.
124. Bush RK, Portnoy JM. The role and abatement of fungal allergens in allergic diseases. *J Allergy Clin Immunol* 2001;107:S430–40.
125. Halonen M, Stern D, Wright AL, Taussig LM, Martinez FD. *Alternaria* as a major allergen for asthma in children raised in a desert environment. *Am J Respir Crit Care Med* 1997;155:1356–61.
126. Bush RK, Portnoy JM, Saxon A, Terr AI, Wood RA. The medical effects of mold exposure. *J Allergy Clin Immunol* 2006;117:326–33.
127. Burge HA, Solomon W, Boise JR. Microbial prevalence in domestic humidifiers. *Appl Environ Microbiol* 1980;39:840–4.
128. Kumar P, Lopez M, Fan W, Cambre K, Elston RC. Mold contamination of automobile air conditioner systems. *Annals Allergy* 1990;64:174–7.
129. Barnes CS, Dowling P, Van Osdol T, Portnoy J. Comparison of indoor fungal spore levels before and after professional home remediation. *Ann Allergy Asthma Immunol* 2007;98:262–8.
130. Chilmonczyk BA, Salmun LM, Megathlin KN, Neveux LM, Palomaki GE, Knight GJ, et al. Association between exposure to environmental tobacco smoke and exacerbations of asthma in children. *N Engl J Med* 1993;328:1665–9.
131. Cook DG, Strachan DP. Health effects of passive smoking. *Thorax* 1999;54:357–66.
132. Matsui EC, Hansel NN, McCormack MC, Rusher R, Breyse PN, Diette GB. Asthma in the inner city and the indoor environment. *Immunol Allergy Clin North Am* 2008;28:665–8.
133. Hansel NN, Breyse PN, McCormack MC, Matsui EC, Curtin-Brosnan J, Williams DL, et al. A longitudinal study of indoor nitrogen dioxide levels and respiratory symptoms in inner-city children with asthma. *Environ Health Perspect* 2008;116:1428–32.
134. National Asthma Education and Prevention Program. Expert panel report III: Guidelines for the diagnosis and management of asthma. Bethesda, MD: National Heart, Lung, and Blood Institute; 2007 (NIH publication no. 08–4051) Full text Available online: <[www.nhlbi.nih.gov/guidelines/asthma/asthgdln.htm](http://www.nhlbi.nih.gov/guidelines/asthma/asthgdln.htm)>.



# Immunotherapy for Allergic Disease

ELIZABETH C. MATSUI | PEYTON A. EGGLESTON

## KEY POINTS

- Subcutaneous immunotherapy is an effective treatment for pediatric patients with allergic rhinitis and stinging insect hypersensitivity, and selected pediatric patients with allergic asthma.
- Sublingual immunotherapy is an approved and effective treatment for seasonal allergic rhinitis due to grass and ragweed pollen allergy.
- There is a small but real risk of systemic allergic reactions with immunotherapy, and the risk associated with subcutaneous immunotherapy appears to be greater than that for sublingual immunotherapy.
- Immunotherapy is associated with changes in humoral and cellular immune responses as well as effector cell responsiveness.
- Oral immunotherapy for food allergy is an active area of investigation.

In 1911, Noon<sup>1</sup> found that by administering increasing doses of grass pollen extract, he could induce a marked decrease in conjunctival sensitivity to grass pollen. It was this observation that eventually led to the widespread use of immunotherapy for the treatment of allergic disease.<sup>1</sup> *Immunotherapy* is the term used to describe a prolonged process of repeated administration of extracts of pollens or other allergen sources to patients with diseases with a demonstrable allergic etiology for the purpose of reducing symptoms. It has also been called *desensitization* or *allergy injection therapy*. It is recommended in most discussions of the treatment of allergic airway disease, along with allergen avoidance and symptomatic drug therapy.

## Principles of Immunotherapy

In allergic rhinitis (AR), the effectiveness of immunotherapy has been demonstrated in many carefully conducted placebo-controlled trials. The results of a typical clinical trial are shown in [Figure 23-1](#).<sup>2</sup> Three groups of patients matched on the basis of their allergic sensitivity to ragweed allergen were treated with injections of whole ragweed pollen extracts, purified Antigen E (Amb a 1) or placebo. Although everyone became symptomatic during the ragweed pollen season, it is obvious that those receiving placebo injections were more symptomatic than those receiving pollen extracts. These trials have been reviewed in detail elsewhere<sup>3</sup> and are addressed here only to review the principles learned for the safe and effective use of immunotherapy.

The first principle is that clinical effectiveness is dose dependent; that is, a certain minimal dose of allergen extract must be administered to produce effective symptomatic control.<sup>4</sup> These extracts are prepared by suspending source material (pollen,

fungal cultures, dust mites or animal pelts) in buffers to extract the water-soluble components into the buffer, and they are now available commercially under license by the US Food and Drug Administration (FDA). Extracts are complex mixtures of dozens of proteins, of which only a few are major allergens. Clinical trials that compare treatment with purified allergens or with partially purified extracts containing high concentrations of allergens with treatment with currently available crude extracts have shown them to be equally effective. For instance, symptoms are reduced to a similar extent with immunotherapy with purified ragweed allergen Amb a 1 and with whole ragweed extract in the study illustrated in [Figure 23-1](#).

Another lesson from these studies is that therapeutic effectiveness of conventional immunotherapy increases with time. Significant improvement is generally not seen before 3 months or more of therapy.<sup>5</sup> It is not clear why such a long time is needed, but in part it reflects the time required to increase the injected dose from the very small dose that can be tolerated initially to the 10,000-fold higher dose that produces immunologic and clinical effects. It is also obvious that immunologic effects must be taking place very early in this process to allow the patient to tolerate increasing doses without anaphylaxis. Clinical benefit increases for several years after the maximal doses of antigens are achieved. Although the reason for the delayed effect of immunotherapy is not clear, it is important to discuss with patients so that their expectations will be realistic. It is important to note, however, that single dose sublingual immunotherapy, which has recently been approved in the United States for grass and ragweed allergy, has a more rapid onset of action, likely because no build-up phase is required, and is efficacious when given only part of the year, prior to and during the relevant pollen season.

In clinical trials when symptom scores are compared with those in untreated patients, a placebo effect is consistently seen. This placebo effect is especially easy to see in the asthma trials, in which most placebo-treated patients improve and 25–30% improve significantly.<sup>5</sup> For clinical investigators, this fact has made it absolutely essential to include a placebo group in any immunotherapy trial. For clinicians, it is important to recognize that there is a significant and powerful placebo effect associated with the repeated injections and frequent visits with sympathetic physicians and nurses. Only by administering concentrated antigen preparations to carefully selected patients are the benefits greater than those seen with sympathetic support.

For most patients, symptomatic improvement is partial and immunotherapy serves to decrease the severity of symptoms without totally eliminating them. In addition, a significant number of allergic patients, perhaps as many as 25%, do not benefit from IT regardless of the potency of the antigen or the length of therapy. The reasons why certain patients are ‘nonresponders’ are unclear, but the point is an important one to bear in mind when discussing immunotherapy with patients.

In clinical trials, systemic anaphylactic reactions are common. Although these are usually mild and not life threatening, they



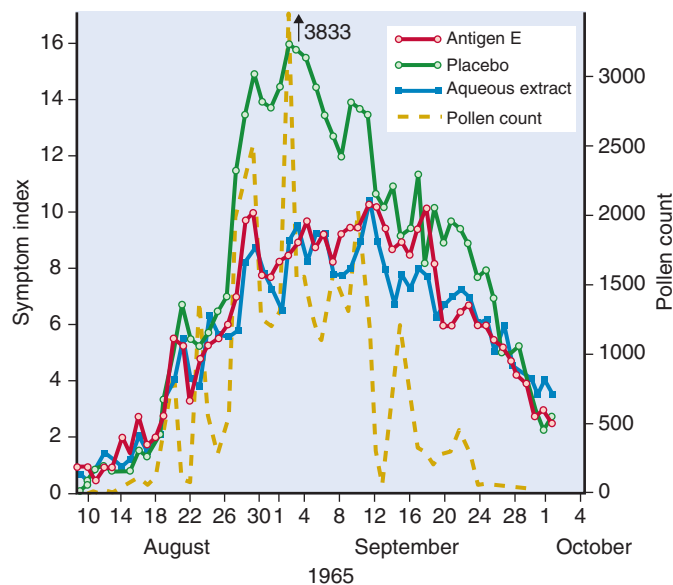

**Figure 23-1** Typical result of an immunotherapy trial in patients allergic to ragweed pollen. (From Norman PS, Winkenwerder WL, Lichtenstein LM, et al. *J Allergy Clin Immunol* 1968;42:93-108.)

may require epinephrine therapy and may be fatal. Such reactions are not surprising because patients are selected who are clearly allergic on the basis of skin tests and/or specific immunoglobulin E (IgE) tests and history of severe symptoms on allergen exposure. In a recent large clinical survey, one fatality out of 23.3 million injection visits was identified, approximately one out of every 1 million injections resulted in a very severe, near-fatal reaction, and one out of every 1000 injections resulted in a systemic reaction.<sup>6</sup>

Research in immunotherapy continues in several directions. Standardization of allergen extracts to make available products with consistent potency has dramatically increased the reliability of commercially available extracts. Studies have demonstrated the safety and efficacy of shortening the dose escalation phase with schedules for rush and ultrarush immunotherapy. Investigators have also been studying adjuvants to improve efficacy of immunotherapy as well as modified allergens to reduce the risk of serious reactions to immunotherapy. Other routes of administering allergen extracts are also being studied, as well as the use of immunotherapy for other allergic diseases such as eczema<sup>7</sup> and food allergy.<sup>8</sup> Finally, immunomodulatory therapies are currently in clinical trials; these include agents such as anti-IgE and anticytokine therapies.

## Mechanisms of Action

Many observations about patients' immunologic and cellular responses to immunotherapy have been made, but the precise mechanism of action of immunotherapy remains unknown. What is generally recognized is that skin test sensitivity decreases and allergen-specific IgG increases with immunotherapy.<sup>9</sup> It is not until after several years of immunotherapy that allergen-specific IgE decreases.<sup>10</sup> There has also been much speculation that immunotherapy acts on the T helper cell type 1 (Th1)/Th2 axis to shift the T cell phenotype away from the allergic Th2 phenotype. More recently, a growing body of evidence suggests that immunotherapy may promote regulatory T cells which may play a role in attenuating allergic symptoms.<sup>11</sup>

## ANTIBODY RESPONSE AND IMMUNOTHERAPY

Studies have consistently demonstrated an increase in allergen-specific IgG and IgE within months of starting immunotherapy. One trial of ragweed immunotherapy in adults that examined allergen-specific antibody responses can be seen in [Figure 23-2](#). Subjects demonstrated significant dose-dependent increases in ragweed-specific IgG long before symptom relief was seen. Ragweed-specific IgE initially increased and did not decrease until years into therapy.<sup>10</sup> Similar observations have been made by other investigators for both venom immunotherapy and inhalant allergen immunotherapy. It has been suggested that allergen-specific IgG acts as blocking antibody either by blocking antigen binding by IgE or by preventing aggregation of the high-affinity IgE receptor (FcεRI) at the cell surface. Although allergen-specific IgG levels do not correlate with clinical efficacy, the functional blocking activity of allergen-specific IgG does appear to correlate with clinical efficacy.<sup>11</sup>

### Effects on T Cells

Because a Th2 phenotype has been associated with allergic disease and a Th1 phenotype with protection against allergic disease, it has been hypothesized that immunotherapy exerts its effects through modulation of the T helper phenotype. This modulation may result in either a shift from the Th2 to Th1 phenotype or through induction of CD8<sup>+</sup> suppressor activity. Indeed, evidence has been published in support of both of these hypotheses. Rocklin and colleagues<sup>12</sup> demonstrated the generation of allergen-specific suppressor cells during immunotherapy and provided evidence that the suppressor cells decrease IgE synthesis. Other studies have examined the cytokine profile of peripheral blood Th2 cells and demonstrated decreases in interleukin (IL)-4 production and, in some cases, concomitant increases in interferon (IFN)-γ production,<sup>11,13</sup> suggesting a modulation of the T helper phenotype from Th2 to Th1. The mechanism of these changes has recently advanced with the recognition of CD4<sup>+</sup>CD25<sup>+</sup> regulatory T cells that are capable of directing the Th1:Th2 balance and are activated by effective immunotherapy, as well as the more recent recognition of a role for regulatory B cells.<sup>11,14</sup>

## EFFECTS ON INFLAMMATORY CELLS

There also is evidence that immunotherapy affects mast cells, basophils and eosinophils. In the first few weeks of immunotherapy, it has been shown that the *in vitro* basophil response to allergen decreases sharply, just as it does during rapid desensitization regimens for patients with drug allergy.<sup>14</sup> One study demonstrated a significant decrease in metachromatic cells (mast cells and basophils) in nasal scrapings after dust mite immunotherapy.<sup>15</sup> Allergen-specific immunotherapy has also been demonstrated to decrease peripheral blood basophil histamine release.<sup>16</sup> In addition, successful immunotherapy has been associated with a decrease in the numbers of eosinophils from nasal and bronchial specimens.<sup>17-19</sup>

## Specific disease indications

### ALLERGIC RHINITIS

Immunotherapy has been demonstrated to be quite effective in both seasonal and perennial AR. Many well-designed studies have examined the efficacy of immunotherapy for pollen-

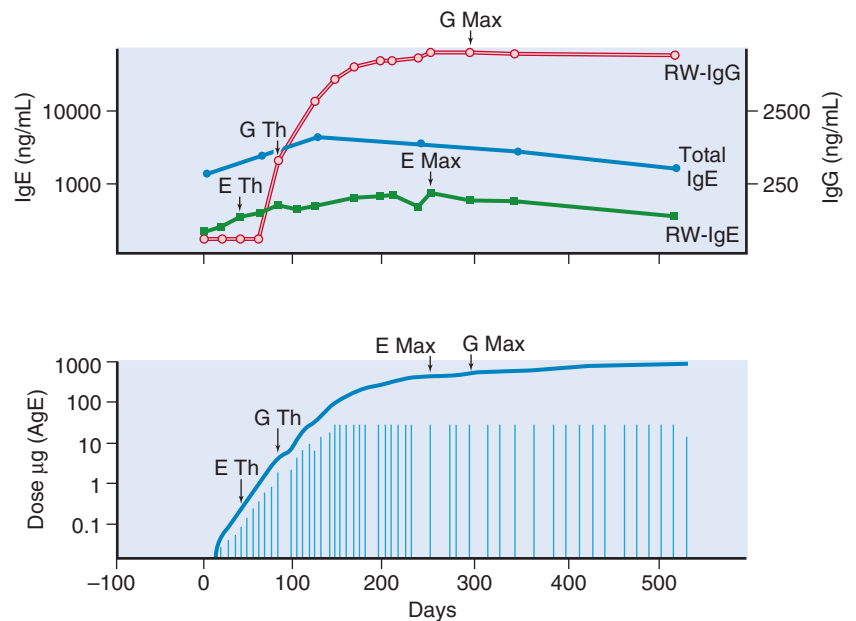

**Figure 23-2** A profile of a typical patient receiving ragweed immunotherapy. (Top) Ragweed-specific IgE (RW-IgE), IgG (RW-IgG) and total IgE responses during ragweed immunotherapy plotted against time expressed in days. E Th – threshold dose for ragweed-specific IgE response; G Th – threshold dose for ragweed-specific IgG response; E Max – maximum ragweed-specific IgE; G Max – maximum ragweed-specific IgG. (Bottom) Cumulative dose (curve) and single doses (lines) plotted against time expressed in days. (From Creticos PS, Van Metre TE, Mardiney MR, et al. *J Allergy Clin Immunol* 1984;73:94–104.)

allergic patients with seasonal AR.<sup>11,20,21</sup> These randomized, controlled trials have been the subject of a meta-analysis which demonstrated significant symptom relief and reduction of medication requirements.<sup>22</sup> Immunotherapy has also been shown to be effective for mite-induced perennial AR<sup>23</sup> and may also be effective in mold-induced rhinitis.<sup>24</sup> The duration of treatment is generally 3 to 5 years, and symptomatic improvement continues for years after discontinuation.

## ASTHMA

Many studies in the past decade have examined the efficacy of immunotherapy for allergic asthma.<sup>9,25–28</sup> Certainly, allergic sensitization and subsequent allergen exposure contribute significantly to asthma morbidity in children, making immunotherapy an appealing option for children with allergic asthma. However, IgE-mediated mechanisms are only part of the underlying pathophysiology of asthma, making the rationale for immunotherapy as a treatment option in allergic asthma less straightforward.

Results of clinical trials examining the efficacy of immunotherapy in allergic asthma have been conflicting. To complicate matters further, many studies have not included placebo arms, making it difficult to draw any conclusions about efficacy from those studies. Abramson and colleagues<sup>29</sup> conducted a meta-analysis of randomized, controlled trials for immunotherapy in asthma. Eighty-eight trials met inclusion criteria of being double blind, randomized and placebo controlled. After analysis of the combined results from these trials, immunotherapy was found to reduce bronchial hyperreactivity and medication use and to improve asthma symptoms. There was no clear effect of immunotherapy on pulmonary function.

A comprehensive review also concluded that immunotherapy is effective in the treatment of asthma but in carefully selected circumstances.<sup>30</sup> The authors concluded that immunotherapy is effective in grass pollen asthma but that results from studies for ragweed asthma were inconclusive. In addition, mite immunotherapy with standardized extracts was effective in reducing symptoms and increasing the threshold dose of mite extract needed to induce bronchial obstruction

in bronchial challenges. The authors also make the point that children receiving mite immunotherapy benefited to a greater extent than adults, and a recent study demonstrated that mite immunotherapy had a steroid-sparing effect in children with asthma.<sup>31</sup>

Immunotherapy for animal-induced asthma has been more controversial. Some proponents of immunotherapy believe that there is a role for animal immunotherapy in the treatment of asthmatic patients who live with pets, but consensus statements from respected international organizations maintain that allergen avoidance is first-line therapy for these patients.<sup>32</sup> There have been carefully conducted, placebo-controlled trials demonstrating the efficacy of specific immunotherapy for cat asthma.<sup>27,33</sup> Studies have demonstrated a decrease in the quantitative airway responsiveness to cat allergen and decreased skin test reactivity in those treated with cat immunotherapy, but studies examining improvement in clinical symptoms have been inconclusive.

Clinical trials evaluating mold immunotherapy for asthma have been published for *Alternaria* and *Cladosporium*. One of the *Cladosporium* trials was conducted in children and demonstrated a decrease in allergen sensitivity on inhalation challenge, but did not provide good evidence of a decrease in symptoms or medication use.<sup>24</sup> Some studies evaluating *Alternaria* immunotherapy have demonstrated an improvement in asthma symptoms and a decrease in medication use.<sup>34</sup> Although there is evidence to support the addition of certain mold extracts to an immunotherapy prescription, more data are needed before any firm conclusions can be made about immunotherapy in mold asthma.

Although many studies support a role for immunotherapy in the treatment of allergic asthma, there have been some studies that have not demonstrated the efficacy of immunotherapy for asthma. One of these was a well-conducted, placebo-controlled trial of immunotherapy for children with allergic asthma, and the investigators found little evidence to support the efficacy of polyvalent (i.e. a mixture of extracts of various allergens) immunotherapy.<sup>9</sup> Both the active treatment and placebo groups had a reduction in medication use and improvement in PD<sub>20</sub> FEV<sub>1</sub>, and the outcomes in the treatment group were not statistically significantly better than those in the

placebo group. Despite the negative results of this well-conducted study, many other published studies have demonstrated the efficacy of immunotherapy for allergic asthma. One of the major differences in this trial is that multiple allergen extracts were included in the injections. Although this is the usual approach to immunotherapy for allergic asthma in the USA, European standards require therapy with a single allergen extract (e.g. dust mite, cat, *Alternaria*), and this trial is the only one dealing with polyvalent immunotherapy. It is possible that this approach differs in some important way from immunotherapy with single-allergen extracts.

## STINGING INSECT

Immunotherapy for venom allergy is highly efficacious, affording protection for more than 95% of individuals undergoing treatment.<sup>35</sup> Although venom immunotherapy is indicated in adults with evidence of IgE to Hymenoptera venom and a history of a systemic reaction to Hymenoptera, the indications in children are somewhat different. Studies of the natural history of venom allergy in children indicate that the risk of a serious reaction from a subsequent sting for a child with a history of a cutaneous systemic reaction is small. There is an approximately 10% incidence of subsequent systemic reactions in this patient population and a 0.4% incidence of more severe reactions involving the respiratory and cardiovascular systems.<sup>36</sup> In light of these findings, venom immunotherapy has been reserved for those children who have had 'life-threatening' reactions to Hymenoptera as well as evidence of IgE to Hymenoptera venom (see also Chapter 57).

## FOOD

Although oral and sublingual immunotherapy are not currently recommended treatments for food allergy, they are being actively investigated. Subcutaneous immunotherapy for foods has proved far too risky to pursue as a treatment option. More recently, several randomized controlled trials of oral immunotherapy (OIT) for several foods, including egg, milk, and peanut have been completed, and although their results have indicated that OIT is a promising treatment for IgE-mediated food allergy, there are some significant limitations that must be addressed before it can be recommended as a treatment.<sup>8</sup> First, reactions are common and unpredictable, so methods for reducing and predicting risk are needed. Second, only approximately 30% of children on active treatment achieve sustained unresponsiveness, meaning that they can tolerate a full serving of the food after stopping OIT for a period of time, typically 1–6 weeks. The remaining children have therefore lost their desensitization, indicating that it was dependent on continued doses of OIT. A more detailed discussion of immunotherapy for food allergy can be found in Chapter 49.

## Practical Considerations

### PATIENT SELECTION

#### *Allergic Rhinitis*

Immunotherapy should be considered for patients with clear evidence of IgE-mediated symptoms who have not been adequately controlled with first-line medical therapy, including antihistamines, nasal corticosteroids and ocular antihistamines

or antiinflammatory medications. Other aspects of the patient's history should be taken into consideration. For example, successful immunotherapy requires that a patient be able to visit a physician's office weekly and spend a minimum of 30 minutes there. Certain medications, such as beta blockers, put a patient at higher risk for systemic reactions to immunotherapy.

#### *Asthma*

Although some of the same principles of patient selection apply, immunotherapy for asthma deserves separate commentary. As in AR, patients must have demonstrable IgE to allergens to which they are exposed and the clinical history should be consistent with exacerbation of asthma symptoms with exposure to the allergens. A patient's ability to visit a medical facility weekly, as well as his or her medications and age, should be taken into consideration. Immunotherapy may be appropriate for treating asthma that has been difficult to control, but it should not be prescribed for patients with unstable asthma and an FEV<sub>1</sub> less than 70% of predicted, so it may be least appropriate for patients who continue to have clinical symptoms of asthma despite maximal medical therapy.

## ALLERGEN EXTRACTS

### *Allergen Extracts for Immunotherapy*

Allergen extracts are prepared by extracting bulk source materials (e.g. pollens, mite cultures, fungal cultures) in aqueous buffers; typically the potency of these extracts is expressed in a ratio of the weight of source material extracted to the extraction volume, such as 1:10 wt/v. Variations in the bulk sources and in the manufacturing process have led to vast differences in the quantity of active allergens in these extracts.<sup>37</sup> A second approach to labeling is based on the total protein content of the extract and is expressed in protein nitrogen units (PNUs); this method has little relationship to allergenic potency but is still commonly used in the USA. Efforts to standardize extracts in Europe and the USA have produced fundamentally different approaches. One approach measures the content of the major allergen or allergens in the mixture using crossed immunoelectrophoresis, immunodiffusion, RAST inhibition or enzyme-linked immunosorbent assay. Another approach compares the biologic activity of the material with the diameter of a control intradermal injection of histamine and expresses this as a BU (biologic unit). The FDA uses a slightly different approach to establish a BU, in which the flare diameter of reference extract in a select group of allergic volunteers is compared with a reference extract, and expresses the result in allergen units (AU) or bioequivalent allergen units (BAU). The results are somewhat confusing, and most commercially available extracts are labeled with more than one method to try to simplify administration of the materials. Studies that have established guidelines for effective maintenance doses for particular allergens report these doses in micrograms of major allergen, but translating wt/v, PNU, BU, AU or BAU into microgram doses can be difficult. Fortunately, some products have also been standardized by the major allergen concentration expressed as micrograms per milliliter (µg/mL). There are also some data translating allergen content into micrograms of major allergen; this information may be helpful in guiding dosing decisions. Table 23-1 is adapted from a recent comparison of labeling methods.<sup>38</sup> Where they are available, standardized extracts should always be used for therapy.

**TABLE 23-1** Major Allergen Content of Extracts

Source	Label	Allergen	N	Mean (µg)	Maximum (µg)	Minimum (µg)
Orchard grass	100,000 BAU/mL	Dac g 5	14	918	2414	294
Short ragweed	1 : 10 wt/v	Amb a 1	13	268	458	87
<i>D. farinae</i>	10,000 AU/mL	Der f 1	18	44	72	30
Cat hair	10,000 BAU/mL	Fel d 1	12	40	52	26
Dog hair	1 : 10 wt/v	Can f 1	4	5.4	7.2	2.7

Modified from Nelson HS. *J Allergy Clin Immunol* 2000;106:41–5.

### Storage

Some loss of potency is usual over time; therefore, manufactured extracts are supplied with expiration dates. These expiration dates are based on the assumption that the extracts will be refrigerated because loss of activity is more rapid at temperatures above 5°C. Loss of potency is faster in more diluted solutions, but it can be decreased by the addition of 50% glycerol or 0.03% human serum albumin. Because glycerol is irritating, most allergen solutions are diluted in albumin-containing buffers. Fungal, dust mite and cockroach extracts have been found to have significant protease activity<sup>39</sup> and therefore may accelerate the deterioration of allergen solutions. Some experts recommend that when making up immunotherapy solutions, dust mite, cockroach and fungal extracts should be placed in vials separate from other allergen extracts that do not contain protease activity.

### Injection Regimens

A prescription for immunotherapy should reflect the patient's demonstrated specific IgE-mediated sensitization, as well as the clinical history of symptoms on exposure and other medical illnesses. The decision is a complex one and should be made by a trained allergist rather than a manufacturer or testing service. Typically, a prescription is written for a treatment set, with one vial containing a 1 : 10 dilution of concentrated material from a manufacturer and three or four other vials containing 10-fold dilutions (i.e. 1 : 100, 1 : 1000, etc.). Each vial of the set should be clearly labeled with the patient's name, the allergens contained in the vial, the dilution and an expiration date.

### Administration and Dosing

Dosing instructions are shown in [Table 23-2](#), modified from Nelson. The principle is that a dose is administered that is 10-fold smaller than the dose that will induce a positive skin test; then increasing doses are administered weekly until a dose 1000 to 10,000 times greater is tolerated ([Table 23-2](#)). Once the maximum dose is reached (0.5 mL of the 1 : 10 dilution in [Table 23-2](#)), the patient continues to receive this dose every other week for the first year. Generally, it takes 6 months of weekly doses to reach the maintenance dose. Alternative dosing schedules have been proposed in which the build-up doses are administered every 20 to 30 minutes (rush immunotherapy) or 2 or 3 times a week (cluster immunotherapy). These regimens allow a patient to reach the maintenance dose in a shorter period of time, but each has a greater risk of allergic reactions to the injections.

### Duration of Immunotherapy

Once maintenance doses have been reached, these are generally continued for 3 years or longer. If a patient is able to tolerate

**TABLE 23-2** Allergen Extract Prescription

Begin with vial A and progress to vial D, which is the most concentrated, or 'maintenance', solution. Injections should be administered subcutaneously every week until the highest maintenance dose is administered, 0.5 mL of vial D. Then repeat this dose every other week for the next year. After the first year, maintenance doses can be given every 3 to 4 weeks.

- Call the center before resuming treatment if the treatment has lapsed by 4 weeks or more.
- During the build-up phase, repeat a dose if the last dose produced local swelling of more than 3 cm in diameter (the size of a silver dollar) or if treatment lapses for 1 to 2 weeks.
- Drop back 2-fold (i.e. from 0.4 to 0.2 mL) if the previous dose has produced local swelling of 5 cm or more in diameter, if a mild systemic reaction occurs, or if treatment lapses for more than 2 weeks.
- Drop back 4-fold (i.e. from 0.4 to 0.1 mL) if a systemic reaction occurs.
- The patient should remain for observation for 30 minutes after each injection.

Vial A (1 : 10,000)	Vial B (1 : 1000)	Vial C (1 : 100)	Vial D (1 : 10)
0.05 mL	0.05 mL	0.05 mL	0.05 mL
0.10 mL	0.10 mL	0.10 mL	0.07 mL
0.20 mL	0.20 mL	0.20 mL	0.10 mL
0.40 mL	0.40 mL	0.40 mL	0.15 mL
			0.20 mL
			0.30 mL
			0.50 mL

Modified from Nelson HS. *Immunotherapy for inhalant allergens*. In: Adkinson NF Jr, Busse WW, Bochner BS, editors. *Middleton's allergy: principles and practice*. 7th ed. St Louis: Mosby; 2008.

two sequential pollen seasons with minimal symptoms or none at all, they are able to stop immunotherapy without a relapse for up to 3 years. Although this has been shown in adult clinical trials,<sup>11</sup> it is likely to be true for children as well. Duration of treatment for asthma is less clear.

### Reactions to Immunotherapy

The risks of immunotherapy are not trivial. Clinical surveys from the 1980s reported that 3% to 7% of patients experience systemic reactions and that one reaction occurs for every 250 to 1600 injections.<sup>40</sup> The American Academy of Asthma, Allergy, and Immunology and the American College of Asthma, Allergy, and Immunology initiated a surveillance program of immunotherapy reactions in 2008, and the most recent results indicate a rate of 1 in 1 million injections for near-fatal reactions and 1 in 1000 injections for systemic reactions.<sup>6</sup> Reactions may be limited to urticaria, but 40% to 73% include respiratory reactions and almost 10% include hypotension; fatal reactions occur in 1 per 2 to 3 million injections.<sup>41</sup> From 70% to 90% of



**BOX 23-1 MINIMUM RESUSCITATION EQUIPMENT FOR ADMINISTERING IMMUNOTHERAPY**

Stethoscope  
 Sphygmomanometer  
 Tourniquet  
 Syringes and needles (some 14 gauge)  
 Equipment for administering oxygen by mask  
 Oral airway  
 Equipment for administering intravenous fluids  
 Aqueous epinephrine 1:1000  
 Injectable and oral diphenhydramine  
 Intravenous corticosteroids  
 Injectable vasopressor

reactions begin within the first 30 minutes of an injection. The risk of reactions is greater during the build-up phase, but about half of the reactions occur during maintenance therapy. Reactions are more common in adolescents and young adults and possibly during pollen or mold seasons. Other risk factors for serious systemic reactions include severe asthma, age of less than 5 years and use of a beta blocker.<sup>42</sup> For these reasons, injections should be given in a medical facility and by personnel who know how to recognize and treat a local and systemic reaction to allergenic extract and who are trained in basic cardiopulmonary resuscitation. Resuscitation equipment should be available (minimal equipment is summarized in Box 23-1). Patients should remain in the facility for 30 minutes after an injection and should report immediately if a reaction begins. Injections should not be administered at home.

**Future Directions****ALLERGOIDS AND ADJUVANTS**

Allergoids are produced by chemically modifying or denaturing native allergens. The goal is to retain the ability of the allergen to elicit an immunologic response (specifically a T cell response) while decreasing the risk of anaphylaxis (the IgE-mediated response). Various chemical agents have been used, including urea, glutaraldehyde and polyethylene glycol. Although some of these agents have appeared promising, the inability to standardize the process of chemical modification has made this approach impractical. Adjuvants are used with the allergen extract to boost immunologic response to immunotherapy in hopes of increasing its efficacy. Substances such as alum, tyrosine absorbate and Freund's adjuvant have been used with the rationale that they have the ability to boost Th1-type immune responses, and more recently there has been interest in using innate immune stimulants such as TLR2, TLR4 and TLR9 ligands as adjuvants.

**PEPTIDES AND RECOMBINANT ALLERGENS**

As more is discovered about T cell epitopes, peptides of major allergens can be produced and used as a means of decreasing the risk of IgE-mediated reactions while retaining immunologic potency. In fact, fragments of both the dust mite allergens Der p 1 and Der f 1 and the cat allergen Fel d 1 were found to contain epitopes that were capable of inducing tolerance in mice.<sup>43</sup> This led to clinical trials that showed that injections of mixtures of

small synthetic peptides containing the Fel d 1 epitope modified T cell responsiveness in allergic patients and decreased symptoms on exposure to cats.<sup>44</sup> The effects were modest, but other groups have improved on some of the immunologic and technical limitations of this prototype peptide vaccine and have begun to study the effect of the new formulation on cat allergy.<sup>45</sup>

**IMMUNE MODULATORS**

Many immune modulators are being actively investigated as therapeutic strategies for allergic disease; these include treatment strategies aimed at IgE as well as those aimed at cytokines. Two such therapies that have made it to human trials are an anti-IgE humanized monoclonal antibody and a humanized monoclonal antibody to IL-5. Anti-IgE was evaluated as a treatment for allergic asthma and AR starting in the 1990s. Milgrom and colleagues<sup>46</sup> conducted a randomized, placebo-controlled trial of anti-IgE in adolescent and adult patients with moderate to severe allergic asthma. Symptom scores in the active treatment groups were improved compared with the placebo arm, but perhaps the most striking result was the steroid-sparing effect of anti-IgE. Anti-IgE has also been shown to be effective in reducing the symptoms of seasonal AR in adolescents and adults with ragweed allergy.<sup>47</sup> One randomized, double-blinded study in children and adolescents examined its therapeutic value in seasonal AR when added to immunotherapy. Those subjects receiving anti-IgE in addition to specific immunotherapy had significant reduction in symptoms compared with those receiving immunotherapy alone.<sup>48</sup> The currently available anti-IgE medication, omalizumab, is approved for use in patients 12 years and older with sensitization to a perennial aeroallergen and moderate to severe persistent asthma.

Monoclonal anti-IL-5 has been demonstrated in a placebo-controlled trial to significantly reduce peripheral and sputum eosinophilia without affecting the early- or late-phase responses with inhaled allergen challenges.<sup>49</sup> Despite serious methodologic concerns regarding this study,<sup>50</sup> it has tempered enthusiasm for anti-IL-5 therapy. Recent studies in a rare form of adult-onset asthma characterized by persistent eosinophilia, despite systemic corticosteroid therapy, have demonstrated significant benefit in terms of reduced exacerbations and steroid requirement.<sup>51</sup> Antagonists to IL-4, IL-13, thymic stromal lymphopoietin (TSLP), TNF- $\alpha$ , and IL-17 are also in various stages of development.<sup>52,53</sup>

**ALTERNATIVE ROUTES OF ADMINISTRATION**

Interest in sublingual swallow immunotherapy (SLIT) began in Europe as a method to reduce the risk of serious allergic reactions to therapy. Since then, many clinical trials have examined efficacy and safety, and the results of these trials have been examined in recent meta-analyses. In adults with allergic rhinitis, 49 high quality randomized clinical trials were identified and demonstrated a significant reduction in symptoms ( $P < .0001$ ) and medication requirements ( $P = .0001$ ).<sup>54</sup> In children with asthma, nine high quality trials were examined and the reduction in symptoms and medication requirements was significant, although less consistent than that seen in adults.<sup>55,56</sup> Dose requirements of relevant aeroallergens are now better defined and an order of magnitude larger than those used for injection immunotherapy. Successful studies using these doses produce symptomatic changes and immunologic changes

similar to those seen with injection immunotherapy. Systemic reactions are uncommon, but local (oral and gastrointestinal) reactions are common. SLIT for grass pollen and ragweed for patients with allergic rhinitis has been approved by the FDA for use in the US and data on perennial allergen SLIT are emerging. The ragweed formulation is only approved for adults and the two grass pollen formulations are approved down to ages 5 and 10 years, respectively. SLIT products generally contain either a single dose of allergen or two doses of allergen, so there is little to no build-up phase, and they can be used prior to and during the relevant pollen season. Contraindications include severe, unstable or uncontrolled asthma, eosinophilic esophagitis, a history of a severe allergic reaction or any severe local reaction to sublingual allergen immunotherapy, and hypersensitivity to any of the inactive ingredients. Patients should take the first dose in a medical setting and be observed for 30 minutes and have auto-injectable epinephrine available for subsequent home doses. Other routes under study include intralymphatic and epicutaneous immunotherapy.

### IMMUNOTHERAPY AS PREVENTION

Immunotherapy has traditionally been used as a therapeutic intervention rather than a preventive one. However, some evidence suggests that specific immunotherapy may have a future role in the secondary prevention of allergic diseases. The Preventative Allergy Treatment Study is a European multicenter, randomized trial of specific immunotherapy for seasonal AR. Among those children without asthma, those who had received 3 years of immunotherapy had significantly fewer asthma symptoms than those in the open control group.<sup>57</sup> The children who had received immunotherapy continued to be at lower risk for asthma 10 years after initiation of treatment.<sup>58</sup> In addition, a study evaluating dust mite immunotherapy in monosensitized children demonstrated a decreased risk of the development of additional sensitizations in the active treatment group compared with the control group.<sup>59</sup> The evidence is preliminary, but there is a suggestion that immunologic intervention at an early stage of immune development may alter the natural progression of the allergic phenotype.

### Conclusions

Immunotherapy is an effective treatment option for pediatric patients with stinging insect hypersensitivity and AR (Box 23-2). It is also effective in selected patients with asthma. There is a small but definite risk of systemic allergic reactions;

#### BOX 23-2 KEY CONCEPTS

##### Principles of Immunotherapy

- Efficacy is dose dependent.
- Clinical effectiveness occurs after maintenance doses are reached.
- There is a significant placebo effect.
- Approximately 75% of patients respond.
- A major risk is systemic reaction.

#### BOX 23-3 THERAPEUTIC PRINCIPLES

##### Clinical Principles of Allergen Immunotherapy

- Immunotherapy is effective only in IgE-mediated diseases such as stinging insect anaphylaxis, allergic rhinitis and asthma.
- Patients should be selected who have demonstrated specific IgE and in whom medical management has not adequately controlled disease.
- Successful therapy requires that maximal tolerated doses of allergen extracts be given and requires months to years to reach maximal benefit.
- Because of the risk of anaphylaxis during therapy, injections should be administered in a physician's office or other medical facility that can support cardiorespiratory resuscitation. Patients should be observed for 30 minutes after an injection is administered.

therefore facilities administering immunotherapy should be adequately prepared to handle such an event and patients should remain in the medical facility for 30 minutes after receiving the injection (Box 23-3).

Immunotherapy may act to suppress allergic symptoms through modification of antibody responses, lymphocyte responses or target cell responses to allergen. Studies are under way to determine whether modifications of immunotherapy reagents or dosing route will improve its efficacy or reduce side-effects. Immunotherapy is also being pursued as a treatment option for food allergy, and there is some evidence to suggest that immunotherapy may alter the natural progression of sensitization.

The complete reference list can be found on the companion Expert Consult website at <http://www.expertconsult.inkling.com>.

### KEY REFERENCES

- Keet CA, Wood RA. Emerging therapies for food allergy. *J Clin Invest* 2014;124:1880–6.
- Akdis M, Akdis CA. Mechanisms of allergen-specific immunotherapy: multiple suppressor factors at work in immune tolerance to allergens. *J Allergy Clin Immunol* 2014;133:621–31.
- Abramson MJ, Puy RM, Weiner JM. Injection allergen immunotherapy for asthma. *Cochrane Database Syst Rev* 2010;8:CD001186.
- Cox L, Nelson H, Lockey R, Calabria C, Chacko T, Finegold I, et al. Allergen immunotherapy: a practice parameter third update. *J Allergy Clin Immunol* 2011;127(Suppl. 1):S1–55.
- Valentine MD, Schuberth KC, Kagey-Sobotka A, Graft DF, Kwitovich KA, Szkló M, et al. The value of immunotherapy with venom in children with allergy to insect stings. *N Engl J Med* 1990;323:1601–3.
- Nelson HS. The use of standardized extracts in allergen immunotherapy. *J Allergy Clin Immunol* 2000;106(1 Pt 1):41–5.
- Milgrom H, Fick RB Jr, Su JQ, Reimann JD, Bush RK, Watrous ML, et al. Treatment of allergic asthma with monoclonal anti-IgE antibody. rhuMab-E25 Study Group. *N Engl J Med* 1999;341:1966–73.
- Walsh GM. An update on biologic-based therapy in asthma. *Immunotherapy* 2013;5:1255–64.
- Radulovic S, Wilson D, Calderon M, Durham S. Systematic reviews of sublingual immunotherapy (SLIT). *Allergy* 2011;66:740–52.
- Larenas-Linnemann D. Sublingual immunotherapy in children: complete and updated review supporting evidence of effect. *Curr Opin Allergy Clin Immunol* 2009;9:168–76.

## REFERENCES

- Noon L. Prophylactic inoculation for hay fever. *Lancet* 1911;1:1572.
- Norman PS, Winkenwerder WL, Lichtenstein LM. Immunotherapy of hay fever with ragweed antigen E: comparisons with whole pollen extract and placebos. *J Allergy* 1968;42:93–108.
- The current status of allergen immunotherapy (hyposensitisation). Report of a WHO/IUIS working group. *Allergy* 1989;44:369–79.
- Johnstone DE. Study of the role of antigen dosage in the treatment of pollenosis and pollen asthma. *AMA J Dis Child* 1957;94:1–5.
- Warner JO, Price JF, Soothill JF, Hey EN. Controlled trial of hyposensitisation to *Dermatophagoides pteronyssinus* in children with asthma. *Lancet* 1978;2:912–15.
- Epstein TG, Liss GM, Murphy-Berendts K, Bernstein DI. AAAAI/ACAAI surveillance study of subcutaneous immunotherapy, years 2008–2012: an update on fatal and nonfatal systemic allergic reactions. *J Allergy Clin Immunol Pract* 2014;2:161–7.
- Gendelman SR, Lang DM. Specific immunotherapy in the treatment of atopic dermatitis: a systematic review using the GRADE system. *Ann Allergy Asthma Immunol* 2013;111:555–61.
- Keet CA, Wood RA. Emerging therapies for food allergy. *J Clin Invest* 2014;124:1880–6.
- Adkinson NF Jr, Eggleston PA, Eney D, Goldstein EO, Schuberth KC, Bacon JR, et al. A controlled trial of immunotherapy for asthma in allergic children. *N Engl J Med* 1997;336:324–31.
- Creticos PS, Van Metre TE, Mardiney MR, Rosenberg GL, Norman PS, Adkinson NF Jr. Dose response of IgE and IgG antibodies during ragweed immunotherapy. *J Allergy Clin Immunol* 1984;73(1 Pt 1):94–104.
- Eifan AO, Shamji MH, Durham SR. Long-term clinical and immunological effects of allergen immunotherapy. *Curr Opin Allergy Clin Immunol* 2011;11:586–93.
- Rocklin RE, Sheffer AL, Greineder DK, Melmon KL. Generation of antigen-specific suppressor cells during allergy desensitization. *N Engl J Med* 1980;302:1213–19.
- Durham SR, Ying S, Varney VA, Jacobson MR, Sudderick RM, Mackay IS, et al. Grass pollen immunotherapy inhibits allergen-induced infiltration of CD4+ T lymphocytes and eosinophils in the nasal mucosa and increases the number of cells expressing messenger RNA for interferon-gamma. *J Allergy Clin Immunol* 1996;97:1356–65.
- Akdis M, Akdis CA. Mechanisms of allergen-specific immunotherapy: multiple suppressor factors at work in immune tolerance to allergens. *J Allergy Clin Immunol* 2014;133:621–31.
- Otsuka H, Mezawa A, Ohnishi M, Okubo K, Seki H, Okuda M. Changes in nasal metachromatic cells during allergen immunotherapy. *Clin Exp Allergy* 1991;21:115–19.
- Patil SU, Shreffler WG. Immunology in the Clinic Review Series; focus on allergies: basophils as biomarkers for assessing immune modulation. *Clin Exp Immunol* 2012;167:59–66.
- Creticos PS, Adkinson NF Jr, Kagey-Sobotka A, Proud D, Meier HL, Naclerio RM, et al. Nasal challenge with ragweed pollen in hay fever patients. Effect of immunotherapy. *J Clin Invest* 1985;76:2247–53.
- Furin MJ, Norman PS, Creticos PS, Proud D, Kagey-Sobotka A, Lichtenstein LM, et al. Immunotherapy decreases antigen-induced eosinophil cell migration into the nasal cavity. *J Allergy Clin Immunol* 1991;88:27–32.
- Rak S, Lowhagen O, Venge P. The effect of immunotherapy on bronchial hyperresponsiveness and eosinophil cationic protein in pollen-allergic patients. *J Allergy Clin Immunol* 1988;82(3 Pt 1):470–80.
- Varney VA, Gaga M, Frew AJ, Aber VR, Kay AB, Durham SR. Usefulness of immunotherapy in patients with severe summer hay fever uncontrolled by antiallergic drugs. *BMJ* 1991;302:265–9.
- Lowell FC, Franklin W. A double-blind study of the effectiveness and specificity of injection therapy in ragweed hay fever. *N Engl J Med* 1965;273:675–9.
- Calderon MA, Alves B, Jacobson M, Hurwitz B, Sheikh A, Durham S. Allergen injection immunotherapy for seasonal allergic rhinitis. *Cochrane Database Syst Rev* 2007;1:CD001936.
- Bousquet J, Hejjaoui A, Clauzel AM, Guerin B, Dhivert H, Skassa-Brociek W, et al. Specific immunotherapy with a standardized *Dermatophagoides pteronyssinus* extract. II. Prediction of efficacy of immunotherapy. *J Allergy Clin Immunol* 1988;82:971–7.
- Dreborg S, Agrell B, Foucard T, Kjellman NI, Koivikko A, Nilsson S. A double-blind, multicenter immunotherapy trial in children, using a purified and standardized *Cladosporium herbarum* preparation. I. Clinical results. *Allergy* 1986;41:131–40.
- Mosbech H, Deckelmann R, de Blay F, Pastorello EA, Trebas-Pietras E, Andres LP, et al. Standardized quality (SQ) house dust mite sublingual immunotherapy tablet (ALK) reduces inhaled corticosteroid use while maintaining asthma control: a randomized, double-blind, placebo-controlled trial. *J Allergy Clin Immunol* 2014;134:568–75, e7.
- Ohman JL Jr. Allergen immunotherapy in asthma: evidence for efficacy. *J Allergy Clin Immunol* 1989;84:133–40.
- Van Metre TE Jr, Marsh DG, Adkinson NF Jr, Kagey-Sobotka A, Khattignavong A, Norman PS Jr, et al. Immunotherapy for cat asthma. *J Allergy Clin Immunol* 1988;82:1055–68.
- Bousquet J, Maasch HJ, Hejjaoui A, Skassa-Brociek W, Wahl R, Dhivert H, et al. Double-blind, placebo-controlled immunotherapy with mixed grass-pollen allergoids. III. Efficacy and safety of unfractonated and high-molecular-weight preparations in rhinoconjunctivitis and asthma. *J Allergy Clin Immunol* 1989;84(4 Pt 1):546–56.
- Abramson MJ, Puy RM, Weiner JM. Injection allergen immunotherapy for asthma. *Cochrane Database Syst Rev* 2010;8:CD001186.
- Bousquet J, Hejjaoui A, Michel FB. Specific immunotherapy in asthma. *J Allergy Clin Immunol* 1990;86(3 Pt 1):292–305.
- Zielen S, Kardos P, Madonini E. Steroid-sparing effects with allergen-specific immunotherapy in children with asthma: a randomized controlled trial. *J Allergy Clin Immunol* 2010;126:942–9.
- Cox L, Nelson H, Lockey R, Calabria C, Chacko T, Finegold I, et al. Allergen immunotherapy: a practice parameter third update. *J Allergy Clin Immunol* 2011;127(1 Suppl.):S1–55.
- Ewbank PA, Murray J, Sanders K, Curran-Everett D, Dreskin S, Nelson HS. A double-blind, placebo-controlled immunotherapy dose-response study with standardized cat extract. *J Allergy Clin Immunol* 2003;111:155–61.
- Kuna P, Kaczmarek J, Kupczyk M. Efficacy and safety of immunotherapy for allergies to *Alternaria alternata* in children. *J Allergy Clin Immunol* 2011;127:502–8, e1–6.
- Hunt KJ, Valentine MD, Sobotka AK, Benton AW, Amodio FJ, Lichtenstein LM. A controlled trial of immunotherapy in insect hypersensitivity. *N Engl J Med* 1978;299:157–61.
- Valentine MD, Schuberth KC, Kagey-Sobotka A, Graft DF, Kwitrovich KA, Szklo M, et al. The value of immunotherapy with venom in children with allergy to insect stings. *N Engl J Med* 1990;323:1601–3.
- Chapman MD, Ferreira F, Villalba M, Cromwell O, Bryan D, Becker WM, et al. The European Union CREATE project: a model for international standardization of allergy diagnostics and vaccines. *J Allergy Clin Immunol* 2008;122:882–9, e2.
- Nelson HS. The use of standardized extracts in allergen immunotherapy. *J Allergy Clin Immunol* 2000;106(1 Pt 1):41–5.
- Stewart GA, Thompson PJ, McWilliam AS. Biochemical properties of aeroallergens: contributory factors in allergic sensitization? *Pediatr Allergy Immunol* 1993;4:163–72.
- Greenberg MA, Kaufman CR, Gonzalez GE, Rosenblatt CD, Smith LJ, Summers RJ. Late and immediate systemic-allergic reactions to inhaled allergen immunotherapy. *J Allergy Clin Immunol* 1986;77:865–70.
- Tinkelman DG, Cole WQ 3rd, Tunno J. Immunotherapy: a one-year prospective study to evaluate risk factors of systemic reactions. *J Allergy Clin Immunol* 1995;95(1 Pt 1):8–14.
- Reid MJ, Lockey RF, Turkeltaub PC, Platts-Mills TA. Survey of fatalities from skin testing and immunotherapy 1985–1989. *J Allergy Clin Immunol* 1993;92(1 Pt 1):6–15.
- Briner TJ, Kuo MC, Keating KM, Rogers BL, Greenstein JL. Peripheral T-cell tolerance induced in naive and primed mice by subcutaneous injection of peptides from the major cat allergen Fel d I. *Proc Natl Acad Sci U S A* 1993;90:7608–12.
- Norman PS, Ohman JL Jr, Long AA, Creticos PS, Gefter MA, Shaked Z, et al. Treatment of cat allergy with T-cell reactive peptides. *Am J Crit Care Med* 1996;154(6 Pt 1):1623–8.
- Worm M, Lee HH, Kleine-Tebbe J, Hafner RP, Laidler P, Healey D, et al. Development and preliminary clinical evaluation of a peptide immunotherapy vaccine for cat allergy. *J Allergy Clin Immunol* 2011;127:89–97, e1–14.
- Milgrom H, Fick RB Jr, Su JQ, Reimann JD, Bush RK, Watrous ML, et al. Treatment of allergic asthma with monoclonal anti-IgE antibody. *rhuMAB-E25 Study Group*. *N Engl J Med* 1999;341:1966–73.
- Casale TB, Condemi J, LaForce C, Nayak A, Rowe M, Watrous M, et al. Effect of omalizumab on symptoms of seasonal allergic rhinitis: a randomized controlled trial. *JAMA* 2001;286:2956–67.
- Kuehr J, Brauburger J, Zielen S, Schauer U, Kamin W, Von Berg A, et al. Efficacy of combination treatment with anti-IgE plus specific immunotherapy in polysensitized children and adolescents with seasonal allergic rhinitis. *J Allergy Clin Immunol* 2002;109:274–80.

49. Leckie MJ, ten Brinke A, Khan J, Diamant Z, O'Connor BJ, Walls CM, et al. Effects of an interleukin-5 blocking monoclonal antibody on eosinophils, airway hyper-responsiveness, and the late asthmatic response. *Lancet* 2000; 356:2144–8.
50. O'Byrne PM, Inman MD, Parameswaran K. The trials and tribulations of IL-5, eosinophils, and allergic asthma. *J Allergy Clin Immunol* 2001;108:503–8.
51. Nair P, Pizzichini MM, Kjarsgaard M, Inman MD, Efthimiadis A, Pizzichini E, et al. Mepolizumab for prednisone-dependent asthma with sputum eosinophilia. *N Engl J Med* 2009;360: 985–93.
52. Walsh GM. An update on biologic-based therapy in asthma. *Immunotherapy* 2013;5: 1255–64.
53. Gauvreau GM, O'Byrne PM, Boulet LP, Wang Y, Cockcroft D, Bigler J, et al. Effects of an anti-TSLP antibody on allergen-induced asthmatic responses. *N Engl J Med* 2014;370: 2102–10.
54. Radulovic S, Wilson D, Calderon M, Durham S. Systematic reviews of sublingual immunotherapy (SLIT). *Allergy* 2011;66:740–52.
55. Penagos M, Passalacqua G, Compalati E, Baena-Cagnani CE, Orozco S, Pedroza A, et al. Metaanalysis of the efficacy of sublingual immunotherapy in the treatment of allergic asthma in pediatric patients, 3 to 18 years of age. *Chest* 2008;133:599–609.
56. Larenas-Linnemann D. Sublingual immunotherapy in children: complete and updated review supporting evidence of effect. *Curr Opin Allergy Clin Immunol* 2009;9:168–76.
57. Moller C, Dreborg S, Ferdousi HA, Halken S, Host A, Jacobsen L, et al. Pollen immunotherapy reduces the development of asthma in children with seasonal rhinoconjunctivitis (the PAT-study). *J Allergy Clin Immunol* 2002;109: 251–6.
58. Jacobsen L, Niggemann B, Dreborg S, Ferdousi HA, Halken S, Host A, et al. Specific immunotherapy has long-term preventive effect of seasonal and perennial asthma: 10-year follow-up on the PAT study. *Allergy* 2007;62:943–8.
59. Pajno GB, Barberio G, De Luca F, Morabito L, Parmiani S. Prevention of new sensitizations in asthmatic children monosensitized to house dust mite by specific immunotherapy. A six-year follow-up study. *Clin Exp Allergy* 2001;31: 1392–7.



# Allergic Rhinitis

DEBORAH A. GENTILE | NICOLE PLESKOVIC | ASHTON BARTHOLOW | DAVID P. SKONER

## KEY POINTS

- There are many different causes of rhinitis in children and 50% of all cases of rhinitis are caused by allergy.
- On the basis of timing and duration of allergen exposure, allergic rhinitis is classified as seasonal, perennial or mixed (perennial with seasonal exacerbation).
- A careful history and physical examination are the most effective diagnostic tools for the identification of allergic rhinitis in children.
- Diagnostic tests for allergic rhinitis include in vivo skin testing and in vitro serum IgE antibody immunoassay.
- Specific treatment options for allergic rhinitis include environmental control for allergen avoidance, pharmacotherapy and immunotherapy.

*Rhinitis* is defined as inflammation of the membranes lining the nose and is characterized by one or more of the following nasal symptoms: sneezing, itching, rhinorrhea and nasal congestion. Rhinitis is frequently accompanied by symptoms that involve the eyes, ears and throat.<sup>1,2</sup> Approximately 50% of all cases of rhinitis are caused by allergy. In allergic rhinitis, symptoms arise as a result of inflammation induced by an immunoglobulin E (IgE)-mediated immune response to specific allergens that involves the release of inflammatory mediators and the activation and recruitment of cells to the nasal mucosa.<sup>1,2</sup> A careful history and physical examination are the most effective tools for diagnosing allergic rhinitis, and specific diagnostic testing should be pursued when indicated. Management options for allergic rhinitis include treatment with pharmacologic agents and preventative measures such as environmental controls and immunotherapy.

## Epidemiology

There are several limitations regarding epidemiologic studies of allergic rhinitis. First, most data regarding the true prevalence of allergic rhinitis are difficult to interpret because the majority of studies use either a physician diagnosis of disease or results from patient-administered surveys and/or phone interviews. Results of both types of studies are likely to under-report the actual prevalence of allergic rhinitis.<sup>2-7</sup> Additionally, most epidemiologic studies focus on seasonal allergic rhinitis because of the easy identification of symptoms association with pollen exposure. Perennial allergic rhinitis is more difficult to identify because its symptom complex often overlaps with chronic

sinusitis, recurrent upper respiratory tract infections and vasomotor rhinitis.

The current prevalence of allergic rhinitis in the USA is reported to be approximately 30% for adults and 42% for children.<sup>5</sup> In 2013, allergic rhinitis was reported to affect about 60 million people in the USA, with about 40% of those affected being children. The Allergies, Immunotherapy, and Rhinoconjunctivitis (AIRS) surveys reported seasonal symptoms in 78% of subjects with the most common triggers being pollen (53%), dust (26%) and grass (26%), and nasal congestion being the most bothersome symptom.<sup>2,3</sup> The frequency of allergic rhinitis in the general population has risen in parallel with that of all IgE-mediated diseases during the past decade. The International Study of Asthma and Allergies in Childhood (ISAAC) showed that the prevalence of allergic rhinitis in US children rose from 13.4% in 1994 to 19.1% in 2003.<sup>8</sup>

## SEX

At ages 6 to 7, boys with allergic rhinitis outnumber girls; however, at ages 13 to 14, girls outnumber boys.<sup>9</sup> In general, equal numbers are affected during adulthood.

## AGE

Symptoms of allergic rhinitis develop before the age of 20 years in approximately 80% of cases. Children in families with a bilateral family history of allergy generally have symptoms before puberty; those with a unilateral family history tend to have symptoms later in life or not at all.<sup>5-7</sup>

## RISK FACTORS

The frequency of allergic rhinitis increases with age and positive allergy skin tests have been identified as a significant risk factor for disease development. Disease prevalence is higher in more affluent socioeconomic classes, minorities, areas with heavy outdoor air pollution, individuals with a family history of allergy, firstborn children and individuals born during pollen season.<sup>10</sup> Childhood studies have confirmed that disease risk is increased in those with early introduction of food or formula, maternal tobacco smoking, indoor allergen exposure, elevated serum IgE levels, positive allergy skin tests and parental allergic disorders.<sup>5</sup> Recent studies demonstrated associations between obesity, nutrition, vitamin D deficiency, stress/anxiety, poor housing and allergic predisposition.<sup>11-13</sup> Maternal diets high in antioxidants and omega-3 fatty acids, and pediatric diets high in antioxidants and food diversity are associated with decreased risks of atopy.<sup>14,15</sup> Additionally, probiotics have been found to be effective in treating pediatric atopy.<sup>11,13</sup>

## SOCIOECONOMIC IMPACT

Because of the high prevalence of allergic rhinitis, impaired quality of life, costs of treatment and the presence of co-morbidities such as asthma, sinusitis and otitis media, it has a tremendous impact on society. The severity of allergic rhinitis ranges from mild to seriously debilitating. The cost of treating allergic rhinitis and indirect costs related to loss of workplace productivity resulting from the disease are significant and substantial. Allergic rhinitis was noted as the illness that caused the greatest loss of productivity in the workplace. The estimated cost of allergic rhinitis, based on direct and indirect costs, was approximately \$11 billion for 2005, exclusive of costs for associated medical problems such as sinusitis and asthma.<sup>16</sup> In children with allergic rhinitis, the quality of life of both the parents and the child, including the ability to learn, may be affected.

## Pathophysiology

Under normal conditions, the nasal mucosa quite efficiently humidifies and cleans inspired air. This is the result of orchestrated interactions of local and humoral mediators of defense.<sup>17</sup> In allergic rhinitis, these mechanisms do not function appropriately and contribute to signs and symptoms of the disorder.<sup>18</sup>

## COMPONENTS OF THE ALLERGIC RESPONSE

The tendency to develop IgE, mast cell and T helper cell type 2 (Th2) lymphocyte immune responses is inherited by atopic individuals. Exposure to threshold concentrations of allergens for prolonged periods of time leads to the presentation of the allergen by antigen-presenting cells to CD4<sup>+</sup> T lymphocytes, which then release interleukin (IL)-3, -4 and -5 and other Th2 cytokines. These cytokines drive proinflammatory processes, such as IgE production, against these allergens through the mucosal infiltration and actions of plasma cells, mast cells and eosinophils. Once an individual becomes sensitized, subsequent exposures trigger a cascade of events that result in the symptoms of allergic rhinitis. The response in allergic rhinitis can be divided into two phases: the *early-phase* response and the *late-phase* response.

### Early Phase

During periods of continuous allergen exposure, increasing numbers of IgE-coated mast cells traverse the epithelium, recognize the mucosally deposited allergen, and degranulate.<sup>19</sup> Products of this degranulation include preformed mediators such as histamine, tryptase (mast cell-specific marker), chymase (connective tissue mast cells only), kininogenase (generates bradykinin), heparin and other enzymes. In addition, mast cells secrete several inflammatory mediators de novo, including prostaglandin D<sub>2</sub> and sulfidopeptidyl leukotrienes C<sub>4</sub>, D<sub>4</sub> and E<sub>4</sub>. These mediators cause blood vessels to leak and produce the mucosal edema and watery rhinorrhea that are characteristic of allergic rhinitis. Glands secrete mucoglycoconjugates and antimicrobial compounds and dilate blood vessels to cause sinusoidal filling and thus occlusion and congestion of nasal air passages. These mediators also stimulate sensory nerves, which convey the sensation of nasal itch and congestion, and recruit systemic reflexes such as sneezing. These responses develop within minutes of allergen exposure and thus constitute the

early-phase allergic response.<sup>20</sup> Sneezing, itching and copious, clear rhinorrhea are characteristic symptoms during early-phase allergic responses, although some degree of nasal congestion can also occur.

### Late Phase

The mast cell-derived mediators released during early-phase responses are hypothesized to act on postcapillary endothelial cells to promote the expression of vascular adhesion molecule and E-selectin, which facilitate the adhesion of circulating leukocytes to the endothelial cells. Chemoattractant cytokines such as IL-5 promote the infiltration of the mucosa with eosinophils, neutrophils and basophils, T lymphocytes and macrophages.<sup>21,22</sup> During the 4- to 8-hour period after allergen exposure, these cells become activated and release inflammatory mediators, which in turn reactivate many of the proinflammatory reactions of the immediate response. This cellular-driven, late inflammatory reaction is termed the late-phase response. This reaction may be clinically indistinguishable from the early phase, but congestion tends to predominate.<sup>22</sup> Eosinophil-derived mediators such as major basic protein, eosinophil cationic protein and leukotrienes have been shown to damage the epithelium, leading ultimately to the clinical and histologic pictures of chronic allergic disease.

Subsets of the T helper lymphocytes are the likely orchestrators of the chronic inflammatory response to allergens. Th2 lymphocytes promote the allergic response by releasing IL-3, IL-4, IL-5 and other cytokines that promote IgE production, eosinophil chemoattraction and survival in tissues and mast cell recruitment.<sup>23</sup> Cytokines released from Th2 lymphocytes and other cells may circulate to the hypothalamus and result in fatigue, malaise, irritability and neurocognitive deficits that are commonly noted in patients with allergic rhinitis. Cytokines produced during late-phase allergic responses can be reduced by glucocorticoids.<sup>24</sup>

### Role of Th17 Cells

Recently, Th17 cells have been identified as an important regulator of immune responses in allergic rhinitis. These cells produce IL-17A which increases the production of proinflammatory cytokines.<sup>25</sup> After an allergic subject is challenged intranasally with a relevant allergen repeatedly, the amount of allergen required to produce an immediate response decreases.<sup>26</sup> This effect is termed *priming* and is hypothesized to be a result of the influx of inflammatory cells that occurs during late-phase allergic responses, with IL-17A having a role in priming toward the development of immune responses against new allergens. This response is clinically significant because exposure to one relevant allergen may promote an exaggerated response to other allergens in a susceptible individual. The priming phenomenon highlights the need to fully identify the spectrum of allergens to which an individual patient reacts. Additionally, it emphasizes the need to intervene in the allergic cascade at an early time point via the prompt initiation of preseasonal, prophylactic, antiinflammatory therapy.

## CLASSIFICATION

Allergic rhinitis is classified as seasonal or perennial based on the timing and duration of allergen exposure. Overall, approximately 20% of all cases are strictly seasonal, 40% are perennial, and 40% are mixed (perennial with seasonal exacerbation).

### Seasonal Allergic Rhinitis

Tree, grass and weed pollens and outdoor mold spores are common seasonal allergens. The symptoms typically appear during a defined season in which aeroallergens are abundant. The length of seasonal exposure to these allergens is dependent on geographic location. Therefore, familiarity with the pollinating season of the major trees, grasses and weeds of the locale makes the syndrome easier to diagnose.<sup>27</sup> Certain outdoor mold spores also display seasonal variation with the highest levels in the summer and fall months.<sup>28</sup>

Typical symptoms during pollen exposure include the explosive onset of profuse, watery rhinorrhea; nasal congestion and itching; and sneezing; along with frequent allergic symptoms of the eye. The onset and offset of symptoms usually track the seasonal pollen counts. However, hyperresponsiveness to irritant triggers, which develops from the inflammatory reaction of the late phase and priming responses, often persists after cessation of the pollen season. Such triggers include tobacco smoke, noxious odors, changes in temperature, and exercise.

### Perennial Allergic Rhinitis

Year-round exposure to dust mites, cockroaches, indoor molds and cat, dog and other danders leads to persistent tissue edema and infiltration with eosinophils, mast cells, Th2 lymphocytes and macrophages.<sup>29</sup> Perennial allergic rhinitis can also be caused by pollen in areas where pollen is prevalent perennially.

A universally accepted definition of perennial rhinitis does not exist. Most often, it is defined as persisting for longer than 9 months each year and producing two or more of the following symptoms: serous or seromucus hypersecretion, nasal blockage caused by a swollen nasal mucosa, and sneezing paroxysms. Nasal congestion and mucus production (postnasal drip) symptoms predominate in most patients, and sneezing, itching and watery rhinorrhea may be minimal.<sup>2</sup> Because late-phase reactivity is commonly ongoing, it becomes difficult to distinguish early- from late-phase reactions, therefore the history of trigger factor exposure is often difficult to decipher.

### Perennial Allergic Rhinitis with Seasonal Exacerbation

Symptoms of allergic rhinitis may also be perennial with seasonal exacerbation, depending on the spectrum of allergen sensitivities.

## Differential Diagnosis

The causes of rhinitis are summarized in [Box 24-1](#).<sup>2</sup> The most common form of nonallergic rhinitis in children is infectious rhinitis. The symptoms of allergic rhinitis are frequently confused with those of infectious rhinitis when patients complain of a constant cold. Symptoms persisting longer than 2 weeks should prompt a search for a cause other than acute viral infection. If tests for atopy are negative, foreign body rhinitis should be considered in the differential diagnosis. In such cases, symptoms may be acute or chronic and unilateral or bilateral, and the nasal discharge may be bloodstained or foul smelling. Exacerbation of rhinitis symptoms with predominant, clear rhinorrhea in patients with a known history of allergic rhinitis may be difficult to diagnose. The difference between active infection and allergy should be noted. When the history or physical examination is not diagnostic, a nasal smear may be obtained

## BOX 24-1 CAUSES OF RHINITIS

### Allergic Rhinitis

- Seasonal
- Perennial
- Perennial with seasonal exacerbation

### Nonallergic Rhinitis

- Structural/mechanical factors
  - Deviated septum/septal wall anomalies
  - Hypertrophic turbinates
  - Adenoidal hypertrophy
  - Foreign bodies
  - Nasal tumors
    - Benign
    - Malignant
  - Choanal atresia
- Infectious
  - Acute
  - Chronic
- Inflammatory/immunologic
  - Wegener granulomatosis
  - Sarcoidosis
  - Midline granuloma
  - Systemic lupus erythematosus
  - Sjögren's syndrome
  - Nasal polyposis
- Physiologic
  - Ciliary dyskinesia syndrome
  - Atrophic rhinitis
  - Hormonally induced
    - Hypothyroidism
    - Pregnancy
    - Oral contraceptives
    - Menstrual cycle
    - Exercise
    - Atrophic
- Drug induced
  - Rhinitis medicamentosa
  - Oral contraceptives
  - Antihypertensive therapy
  - Aspirin
  - Nonsteroidal antiinflammatory drugs
- Reflex induced
  - Gustatory rhinitis
  - Chemical or irritant induced
  - Posture reflexes
  - Nasal cycle
- Environmental factors
  - Odors
  - Temperature
  - Weather/barometric pressure
  - Occupational
- Nonallergic Rhinitis with Eosinophilia Syndrome
- Perennial Nonallergic Rhinitis (Vasomotor Rhinitis)
- Emotional Factors

From Skoner DP. *J Allergy Clin Immunol* 2001;108:S2–S8.

to aid in differentiation. The presence of more than 5% eosinophils suggests allergic disease, whereas a predominance of neutrophils suggests infection.

Allergy, mucociliary disturbance and immune deficiency may predispose certain individuals to the development of chronic infection.<sup>30,31</sup> Mucociliary abnormalities may be congenital, as in primary ciliary dyskinesia, Young syndrome or cystic fibrosis, or they may be secondary to infection.<sup>32,33</sup> Similarly, immune deficiency may be congenital or acquired.

Tumors or nasal polyps ([Figure 24-1](#)) as well as other conditions (e.g. nasal septal deviation, adenoidal or nasal turbinate

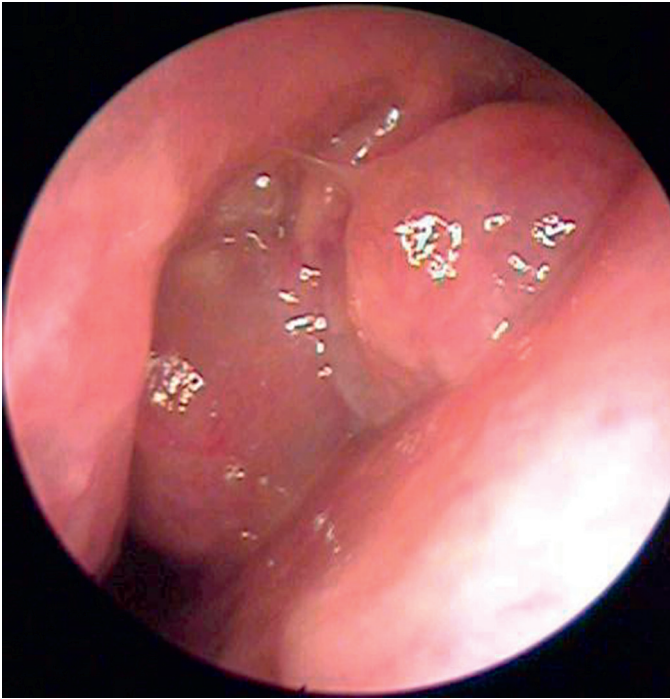

**Figure 24-1** Appearance of nasal polyps on rhinoscopy. (Courtesy of Dr. Sylvan Stool, Department of Otolaryngology, Children's Hospital, Denver, CO.)

hypertrophy) can produce nasal airway obstruction.<sup>34,35</sup> Nasal polyps are common in children with cystic fibrosis but not in children with allergic rhinitis. Nasal septal deviation and nasal turbinate or adenoidal hypertrophy may block the flow of nasal secretions, leading to rhinorrhea or postnasal drip as well as causing nasal blockage. Reduced airflow through the nasal passages in infants may be caused by congenital choanal atresia. Refractory, clear rhinorrhea may be caused by cerebrospinal fluid leak, even in the absence of trauma or recent surgery.

## Evaluation and Management

### HISTORY AND PHYSICAL EXAMINATION

A careful history and physical examination are the most effective diagnostic tools for the identification of allergic rhinitis.<sup>2</sup> The key to accurate and timely diagnosis is a heightened awareness of the condition and its potential co-morbidities. Allergic rhinitis in children is often undiagnosed or misdiagnosed as other disorders such as recurrent colds. To make an accurate and efficient diagnosis, the clinician must be knowledgeable about and attentive to the symptoms and signs of rhinitis, ask specific questions directed at the presence and cause of rhinitis symptoms at each well-child visit, and understand the differential diagnosis of allergic rhinitis in children<sup>2,36</sup> (see [Box 24-1](#)). The clinician must be aware of the co-morbidities of allergic rhinitis (asthma, sinusitis, otitis media), pursue specific diagnostic tests when indicated, and often administer therapeutic trials of antiinflammatory medications.<sup>37,38</sup>

The signs and symptoms of allergic rhinitis are summarized in [Box 24-2](#). Typical symptoms of allergic rhinitis include sneezing, itching, clear rhinorrhea and congestion. Congestion may

### BOX 24-2 SIGNS AND SYMPTOMS OF ALLERGIC RHINITIS

- Itching of the nose, ears, palate or throat
- Sneezing episodes
- Thin, clear rhinorrhea
- Nasal congestion
- Sinus headache
- Eustachian tube dysfunction
- Mouth breathing or snoring
- Chronic postnasal drip
- Chronic, nonproductive cough
- Frequent throat clearing
- Sleep disturbance
- Daytime fatigue

be bilateral or unilateral and may alternate from side to side. It is generally more pronounced at night. With nasal obstruction, the patient is likely to be a mouth breather, and snoring can be a nocturnal symptom. As such, sleep disturbances and daytime tiredness or concentration problems may indicate the presence of an allergic disorder. With chronic disease, abnormalities of facial development, dental malocclusion and the allergic facies may ensue, with an open mouth and gaping habitus.

Older children blow their noses frequently, whereas younger children do not. Instead, they sniff, snort and repetitively clear their throats. Their voices may be abnormally hyponasal. Nasal pruritus may stimulate grimacing and twitching and picking of the nose. The latter may result in epistaxis. Children often have the allergic salute, an upward rubbing of the nose with the palm of the hand. This often produces an allergic nasal crease, which is an accentuated, horizontal skin fold over the lower third of the nose. Children with allergic rhinitis may also have recurrent sinusitis or otitis media, eczema or asthma. Patients may also complain of red, itchy eyes, along with itchy throat and ears. They may also lose their senses of smell and taste. Increased symptoms are frequently noted with increased exposure to the responsible allergen.

With development of the allergic reaction, clear nasal secretions will be evident and the nasal mucous membranes will become edematous without much erythema. The mucosa appears boggy and blue-gray. With continued exposure to the allergen, the turbinates will appear swollen and can obstruct the nasal airway. Conjunctival edema, itching, tearing and hyperemia are frequent findings in patients with associated allergic conjunctivitis. Allergic rhinitis patients, particularly children with significant nasal obstruction and venous congestion, may also demonstrate edema and darkening of the tissues beneath the eyes. These 'shiners' are not pathognomonic for allergic rhinitis; they can also be seen in patients with chronic rhinitis and/or sinusitis.

In severe cases, especially during the peak pollen season, mucous membranes of the eyes, Eustachian tube, middle ear and paranasal sinuses may be involved. This produces conjunctival irritation (itchy, watery eyes), redness and tearing, ear fullness and popping, itchy throat and pressure over the cheeks and forehead. Malaise, weakness and fatigue may also be present. The coincidence of other allergic syndromes, such as atopic eczema or asthma, and a positive family history of atopy point toward an allergic pathology. Approximately 20% of cases are accompanied by symptoms of asthma.<sup>4</sup>



## DIAGNOSTIC TESTS

Laboratory confirmation of the presence of IgE antibodies to specific allergens such as dust mites, pollens and animal dander is helpful in establishing a specific allergic diagnosis, especially if the history of specific allergen exposure is not clear cut. Although skin testing can be performed on any child of any age, children younger than 1 year may not display a positive reaction. Often the child with seasonal respiratory allergy will not have a positive test until after two seasons of exposure. Clinicians should be selective in the use of allergens for skin testing and should use only common allergens of potential clinical importance. The most useful allergens for testing in the child with perennial inhalant allergy are dust mite, animal dander and fungi. Allergens important in the diagnosis of seasonal allergic rhinitis are weed, grass and tree pollen. Because there is a significant geographic specificity with regard to pollens, the importance of these seasonal allergens varies not only by season of the year but also by geographic distribution. Therefore allergens used for skin testing must be individualized and should be selected on the basis of prevalence in the patient's geographic area, as well as home and school environments.

There are two methods for specific IgE antibody testing: in vivo skin testing and in vitro serum testing. Each has advantages and disadvantages<sup>39</sup> (Table 24-1). At the present time, properly performed skin tests are the best available method for detecting the presence of allergen-specific IgE. The skin prick, which is also called the *puncture* or *epicutaneous skin test*, is the preferred method of IgE antibody testing. In vitro tests are acceptable substitutes for skin tests in the following circumstances: (1) the patient has abnormal skin conditions such as dermatographism or extensive dermatitis; (2) the patient cannot or did not discontinue antihistamines or other interfering medications; (3) the patient is very allergic by history and anaphylaxis is a possible risk; and (4) the patient is noncompliant for skin testing. To avoid false-negative tests, most antihistamine medications should be withheld for 72 hours because antihistamines suppress the skin results.

Physicians must remember that positive tests for allergen-specific IgE are not by themselves sufficient for a diagnosis of allergic disease. These tests only indicate the presence of IgE molecules with a particular immunologic specificity. A decision about whether the specific IgE antibodies are responsible for clinically apparent disease must be based on the physician's

assessment of the entire clinical picture. The current standard for the diagnosis of allergic disease remains the combination of (1) positive history, (2) the presence of specific IgE antibodies, and (3) demonstration that the symptoms are the result of IgE-mediated inflammation.

Advances in diagnostic testing are currently evolving with the development of microarrayed recombinant allergens as well as molecular or component-resolved diagnostics. The availability of these technologies is likely to change the future diagnostic landscape for allergic rhinitis. The major advantage of microarray testing is potential incorporation of thousands of allergens that could be assayed in parallel with a very small amount of serum. Additionally, there is potential for greater resolution between clinical reactivity and asymptomatic sensitization with this platform. The major advantage of molecular or component-resolved diagnostics is the use of individual allergen molecules instead of complex whole allergen extracts to specifically characterize IgE specificity. These technologies are in their infancy and large studies will be needed to critically evaluate their diagnostic and prognostic value as compared to current testing modalities.

## GUIDELINES FOR DIAGNOSIS AND MANAGEMENT

Strategies for the evaluation and management of allergic rhinitis are summarized in an algorithm compiled by the Joint Task Force on Practice Parameters in Allergy, Asthma and Immunology<sup>1</sup> (Figure 24-2). As outlined, the initial evaluation of a patient with rhinitis symptoms (e.g. rhinorrhea, nasal congestion, sneezing, nasal pruritus, postnasal drainage and conjunctivitis) should be performed by a primary care physician. The primary care physician should institute an appropriate therapeutic trial. Upon follow-up, the primary care physician should determine if the patient has responded to treatment and/or meets the criteria for consultation with an allergist as summarized in Box 24-3. One of the primary purposes of a consultation with an allergist is the differential diagnosis of allergic rhinitis based on the combined results of a detailed medical history, physical examination of the airway, and ancillary tests, particularly skin tests.

Effective management of allergic rhinitis may require a combination of aggressive avoidance measures, patient education regarding allergen avoidance and the administration of pharmacologic therapy, allergen immunotherapy, management of co-existing conditions and adjustments in pharmacologic therapy. Cooperative follow-up is an essential part of the

TABLE 24-1

**Comparison of In Vivo Skin Tests and In Vitro Serum IgE Antibody Immunoassay in Allergic Diagnosis**

Skin Test	Serum Immunoassay
Less expensive	No patient risk
Greater sensitivity	Patient-doctor convenience
Wide allergen selection	Not suppressed by antihistamines
Results available immediately	Results are quantitative
	Preferable to skin testing in: Dermatographism Widespread dermatitis Uncooperative children

From Skoner DP. *J Allergy Clin Immunol* 2001;108:S2-S8.

### BOX 24-3 INDICATIONS FOR REFERRAL TO AN ALLERGIST/IMMUNOLOGIST

- Prolonged history of rhinitis
- Presence of complications or co-morbid conditions including asthma, otitis media, sinusitis and/or nasal polyposis
- Prior systemic corticosteroid for the treatment of rhinitis
- Treatment that is either ineffective or produces adverse events
- Symptoms that significantly interfere with the patient's functional ability or reduce the quality of life
- Diagnosis of rhinitis medicamentosa
- Need to further define allergic/environmental triggers of rhinitis
- Need for more education

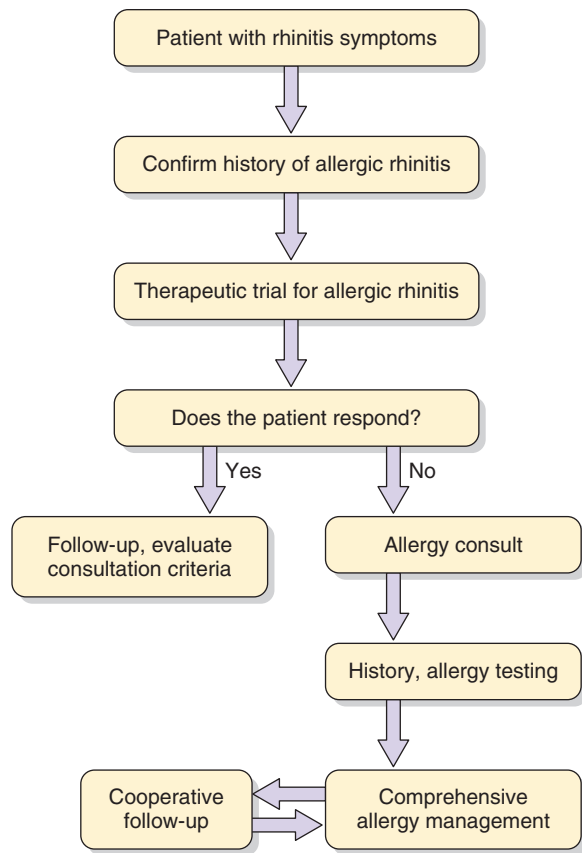

**Figure 24-2** Algorithm for diagnosis and management of rhinitis. (Modified from Wallace DV, Dykewicz MS, Bernstein DI, et al. *J Allergy Clin Immunol* 2008;122:S1–S84.)

successful management of allergic rhinitis and ideally includes the patient, the family and all healthcare providers. With the common goal of reducing symptoms and improving functional ability, all involved would cooperatively manage exacerbations and complications through the optimal use of environmental avoidance measures, medications and immunotherapy in appropriately selected patients. Periodic assessments and continued patient education should also be included in the follow-up protocol.

## MANAGEMENT

Specific treatment options include environmental controls for allergen avoidance, pharmacotherapy and immunotherapy. In all cases, the primary goal of treatment is to control the symptoms and to improve the quality of life without altering the patient's ability to function. A second but equally important goal is to prevent the development of sequelae of allergic rhinitis, including sinusitis, otitis media and asthma exacerbations.<sup>1,38</sup>

### Environmental Control for Allergen Avoidance

Educating families about avoiding exposure to allergens is an essential part of the treatment of allergic rhinitis (Table 24-2). Unfortunately, the specific measures are often highly impractical; moreover, they may have negative psychosocial ramifications for children that should not be ignored. Avoiding outdoor sports in the springtime and banishing furred pets from the

**TABLE 24-2** Environmental Control of Allergen Exposure

Allergens	Control Measures
Dust mites	Encase bedding in airtight covers Wash bedding in water at temperatures >130°F Remove wall-to-wall carpeting Remove upholstered furniture
Animal dander	Avoid furred pets Keep animals out of patient's bedroom
Cockroaches	Control available food supply Keep kitchen/bathroom surfaces dry and free of standing water Professionally exterminate
Mold	Destroy moisture-prone areas Avoid high humidity in patient's bedroom Repair water leaks Check basements, attics and crawl spaces for standing water and mold
Pollen	Keep automobile and house windows closed Control timing of outdoor exposure Restrict camping, hiking and raking leaves Drive in air-conditioned automobile Air-condition the home Install portable, high-efficiency particulate air filters

home, for example, may have adverse effects on children that range beyond allergen control. Nevertheless, families should be taught about the importance of environmental control measures and advised to them to the extent possible.<sup>1</sup>

### Antihistamines

The Joint Task Force on Practice Parameters in Allergy, Asthma and Immunology previously published guidelines on the diagnosis and management of allergic rhinitis, and more recently the Allergic Rhinitis and its Impact on Asthma Guidelines were updated.<sup>40</sup> Antihistamines are available in both oral and nasal formulations. The decision in choosing between an oral or nasal formulation is driven by a variety of factors including insurance coverage, side-effects and patient preference.

Three generations of oral antihistamines are available: the first-generation (sedating) antihistamines, which are available without prescription; the second-generation (hyposedating or nonsedating) agents, which are available without a prescription; and the third-generation (nonsedating metabolites of second-generation agents), all of which require a prescription in the USA at this time (Table 24-3). Oral antihistamines act primarily by blocking the H<sub>1</sub> receptor. The second- and third-generation agents have several advantages over the first-generation agents, including preferential binding to peripheral H<sub>1</sub> receptors, which results in minimal penetration of the central nervous system; minimal antiserotonergic, anticholinergic and  $\alpha$ -adrenergic blocking activities; and minimal sedative and performance-impairing effects.<sup>41,42</sup>

As a general rule, oral antihistamines reduce symptoms of sneezing, pruritus and rhinorrhea but have little or no effect on nasal congestion. Consequently, a topical or oral decongestant may have to be added. Many antihistamine/decongestant formulations are available. The major advantage of these combinations is their convenience. Disadvantages are intolerance of the fixed dose of decongestant in certain patients and an inability to titrate each agent independently.<sup>41,42</sup>

**TABLE 24-3** Second- and Third-Generation Antihistamines

Medication	Formulations	Recommended Dosage
Azelastine	Nasal spray	≥12 yr: 2 sprays per nostril bid 5–11 yr: 1 spray per nostril bid
Cetirizine	Tablets 5, 10 mg Syrup 5 mg/5 mL	≥12 yr: 10 mg qd 6–11 yr: 5–10 mg qd 6 mo–5 yr: 5 mg qd
Desloratadine	Tablets 5 mg Syrup 2.5 mg/5 mL	≥12 yr: 5 mg qd 6–11 yr: 2.5 mg qd 1–5 yr: 1.25 mg qd 6–11 mo: 1 mg qd
Fexofenadine	Capsules/tablets 30, 60, 180 mg Syrup 30 mg/5 mL	≥12 yr: 60 mg bid or 180 mg qd 2–11 yr: 30 mg bid
Levocetirizine	Tablets 5 mg Syrup 2.5 mg/5 mL	≥12 yr: 5 mg qd 6–11 yr: 2.5 mg qd
Loratadine	Tablets 10 mg Syrup 5 mg/5 mL	≥12 yr: 10 mg qd 6–11 yr: 5–10 mg qd 2–5 yr: 5 mg qd
Olopatadine	Nasal spray	≥12 yr: 2 sprays per nostril bid

Patients should be educated about the appropriate use of oral antihistamines. For optimal results, oral antihistamines should be administered prophylactically (2–5 hours before allergen exposure) or on a regular basis if needed chronically. Although oral antihistamines are effective on an as-needed basis, these agents work best when they are administered in a maintenance fashion.<sup>41,42</sup>

Nasal antihistamines relieve sneezing, nasal itching, congestion and postnasal drip. Additionally, they have some efficacy against nasal and sinus congestion. There are currently two second-generation formulations available in the USA including olopatadine, which is available by prescription only as a brand name product, and azelastine which is available by prescription only in brand name and generic products. Onset of action is within minutes and these are often administered on an as-needed basis. Side-effects of these products include a bitter taste, drowsiness and fatigue.<sup>41</sup>

### Decongestants

Decongestants produce vasoconstriction within the nasal mucosa through  $\alpha$ -adrenergic receptor activation and therefore are effective in relieving the symptoms of nasal obstruction. However, these agents have no effect on other symptoms such as rhinorrhea, pruritus or sneezing and may be most effective when used in combination with other agents, such as antihistamines.<sup>41,42</sup>

A number of decongestants are available for oral use, but the most commonly used decongestant is pseudoephedrine. The most common side-effects of oral decongestants are central nervous system (nervousness, insomnia, irritability, headache) and cardiovascular (palpitations, tachycardia) effects. In addition, these drugs may elevate blood pressure, raise intraocular pressure and aggravate urinary obstruction.<sup>41,42</sup>

Topical intranasal decongestants are sometimes used by patients with allergic rhinitis. However, when these agents are used for longer than 3 to 5 days, many patients experience rebound congestion after withdrawal of the drug. If patients

**TABLE 24-4** Intranasal Corticosteroid Sprays

Corticosteroid	Dose per Actuation ( $\mu$ g)	Recommended Dosage
Beclomethasone	42	≥6 yr: 168–336 $\mu$ g/day bid
Budesonide	32	≥12 yr: 64–256 $\mu$ g/day qd 6–11 yr: 64–128 $\mu$ g/day qd
Ciclesonide	50	≥6 yr: 200 $\mu$ g/day qd
Flunisolide	25	≥14 yr: 200–400 $\mu$ g/day bid 6–14 yr: 100–200 $\mu$ g/day bid
Fluticasone furoate	27.5	>12 yr: 110 $\mu$ g/day qd 2–11 yr: 55 $\mu$ g/day qd
Fluticasone propionate	50	≥4 yr: 100–200 $\mu$ g/day qd
Mometasone furoate	50	≥12 yr: 100–200 $\mu$ g/day qd 2–11 yr: 100 $\mu$ g/day qd
Triamcinolone acetonide	55	≥12 yr: 110–220 $\mu$ g/day qd 6–11 yr: 110 $\mu$ g/day qd

Tran NP, Vickery J, Blaiss MS. Management of rhinitis: allergic and non-allergic. *Allergy Asthma Immunol Res* 2011;3:148–156.

continue to use these medications over several months, a form of rhinitis, rhinitis medicamentosa, will develop, which can be difficult to treat effectively.<sup>41,42</sup>

### Intranasal Corticosteroids

Topical intranasal corticosteroids represent the most efficacious agents for the treatment of allergic rhinitis and are useful in relieving symptoms of nasal pruritus, rhinorrhea, sneezing and congestion. These drugs exert their effects through multiple mechanisms, including vasoconstriction and reduction of edema, suppression of cytokine production and inhibition of inflammatory cell influx. Physiologically, prophylactic treatment before nasal allergen challenge reduces both the early- and late-phase allergic responses.<sup>43</sup>

These agents work best when taken regularly on a daily basis or prophylactically in anticipation of an imminent pollen season. However, because of their rapid onset of action (within 12–24 hours for many agents), there is increasing evidence that they may also be effective when used intermittently. A number of glucocorticoid compounds are available for intranasal use in both aerosol and aqueous formulations (Table 24-4). Although the topical potency of these agents varies widely, clinical trials have been unable to demonstrate significant differences in efficacy.<sup>44,45</sup>

The most important pharmacologic characteristic differentiating these agents is systemic bioavailability. After intranasal administration, the majority of the dose is swallowed. Most of the available compounds, including beclomethasone dipropionate, budesonide, flunisolide and triamcinolone acetonide, are absorbed readily from the gastrointestinal tract into the systemic circulation and subsequently undergo significant first-pass hepatic metabolism. The resulting bioavailabilities can be as high as 50%. However, fluticasone propionate, fluticasone furoate and mometasone furoate are not well absorbed through the gastrointestinal tract, and the small amount of drug that reaches the portal circulation is rapidly and thoroughly metabolized. The newest agent, ciclesonide, is administered as a

prodrug and metabolized to a bioactive metabolite by esterases in the nasal mucosa. Ciclesonide has low oral bioavailability due to low gastrointestinal absorption and high first-pass metabolism. The lower systemic availabilities of these newer agents may be most important in growing children and in patients who are already using inhaled corticosteroids for asthma. Nevertheless, there are no studies to document the comparative effects of nasal corticosteroids on growth and development at this time.<sup>46–49</sup>

Patients who use intranasal corticosteroids experience dryness and irritation of the nasal mucous membranes in 5% to 10% of mild cases and mild epistaxis in approximately 5%. For mild adverse events, the dose of intranasal corticosteroid may be reduced if tolerated, and/or saline nasal spray should be instilled before the drug is sprayed. Some patients who do not tolerate the administration of wet spray formulations may benefit by switching to newer dry aerosol formulations including beclomethasone and ciclesonide.<sup>50</sup>

### Combination Nasal Products

Recently, a combination product containing azelastine and fluticasone has been approved by the FDA for use in children older than 12 years.<sup>51</sup> It has the advantage of delivering both an antihistamine and nasal steroid in one product and may subsequently improve compliance. This combination nasal product has been shown to improve symptoms of nasal congestion, rhinorrhea, itchy nose and sneezing when compared to treatment with placebo or treatment with either an antihistamine or a nasal steroid. Adverse effects are similar to those listed for the individual drug components. In addition to azelastine/fluticasone, several other combination products are currently under development.

### Mast Cell Stabilizers

Mast cell stabilizers, such as cromolyn sodium, can be useful in relieving nasal pruritus, rhinorrhea and sneezing; however, they have minimal effects on congestion. Cromolyn sodium is generally well tolerated and is most efficacious when taken prophylactically, well in advance of allergen exposure. In addition, because of its short duration of action, it should be taken 4 times a day; as a result, compliance is difficult for many patients.

### Ipratropium Bromide

Topical intranasal ipratropium bromide 0.03% and 0.06% solution reduces the volume of watery secretions but has little or no effect on other symptoms. Therefore this agent is most helpful in allergic rhinitis, when rhinorrhea is refractory to topical intranasal corticosteroids and/or antihistamines. The most common side-effects include nasal irritation, crusting and mild epistaxis. This drug can be helpful for blocking reflex-mediated rhinitis, profuse rhinorrhea that occurs after the ingestion of spicy foods or cold air exposure.<sup>1</sup> It has not been well researched in the pediatric population.

### Leukotriene Receptor Antagonists

These agents are effective in the treatment of seasonal and perennial allergic rhinitis.<sup>52–55</sup> Because allergic rhinitis often co-exists with asthma, and montelukast is approved for both of these diagnoses, montelukast may be considered in such patients. It should also be considered in patients who are unresponsive or noncompliant with intranasal corticosteroids. Montelukast has an excellent safety profile, is approved down

to 6 months of age, and recently became available in generic formulations. An attractive attribute of this drug is that it is available as a once-daily oral formulation. Dosing is one 10 mg tablet daily for patients  $\geq 14$  years, one 5 mg chewable tablet daily for patients aged 6 to 13 years, and 4 mg daily (chewable tablet or granules) for children of 6 months to 5 years of age. Adverse effects are rare, with the most common complaints being headache or stomachache shortly after dosing.

### Saline

Saline is of benefit in reducing symptoms and improving quality of life in some patients with allergic rhinitis. A recent study demonstrated that hypertonic saline was more effective than isotonic saline in improving outcomes.<sup>56</sup> Various mechanisms of action, including improvement in mucociliary clearance, removal of allergen and inflammatory mediators and a protective effect on nasal mucosa, have been proposed but not confirmed. Side-effects are minimal and include local burning and irritation as well as nausea. Optimal delivery techniques, volumes, concentrations and dose frequency have not been established.

### Allergen Immunotherapy

Specific allergen immunotherapy continues to be a useful and important treatment for many patients with severe allergic rhinitis.<sup>57,58</sup> Specific allergen immunotherapy has traditionally been administered via the subcutaneous route. In making the decision to prescribe subcutaneous immunotherapy, the clinician should consider the positive and potentially negative effects of regular office visits for the administration of injections. If the decision is made to prescribe subcutaneous immunotherapy, it must be administered by a physician who is experienced in its use and whose office is set up to deal with the management of adverse allergic reactions, including anaphylaxis should this rare, untoward event occur.

Recently, several sublingual formulations for the treatment of grass and ragweed pollen allergy have received US Food and Drug Administration (FDA) approval.<sup>59–61</sup> Other sublingual formulations, including but not limited to dust mite and cat, are currently under development in the USA. In controlled trials, this route of delivery appears to be safer with side-effects usually restricted to the upper airways and gastrointestinal tract. However, there are currently neither enough data nor experience with this delivery route to be certain of its safety. This is particularly true in patients with a history of anaphylaxis, eosinophilic esophagitis or uncontrolled asthma. When prescribing sublingual immunotherapy, the first dose must be administered in an allergy specialist's office and the patient must be instructed on the signs and symptoms of anaphylaxis and the use of an epinephrine autoinjector and they must be discharged with an anaphylaxis action plan.

When administered to appropriately selected patients, either formulation of immunotherapy is effective in most cases. In addition to short-term benefits, recently published data suggest that the improvement in rhinitis symptoms persists for several years after the treatment is discontinued.<sup>62</sup> Research performed during the past decade has demonstrated that allergen immunotherapy induces a state of allergen-specific T lymphocyte tolerance with a subsequent reduction in mediator release and tissue inflammation.<sup>63</sup> Immunotherapy should be considered in patients who (1) do not respond to a combination of environmental control measures and medications,



(2) experience substantial side-effects with medications, (3) have symptoms for a significant portion of the year that require daily therapy, or (4) prefer long-term modulation of their allergic symptoms.

## Conclusions

Despite the high prevalence of allergic rhinitis in the pediatric population, this disease is often overlooked or undertreated. Untreated allergic rhinitis impairs the quality of life of the child and his or her parents. Accurate and timely diagnosis of allergic rhinitis in children relies on awareness of the symptoms and signs of the disease and its co-morbidities, including asthma, sinusitis and otitis media. Clinicians should understand the differential diagnosis of allergic rhinitis in children and pursue specific diagnostic testing when indicated. Treatment options include environmental controls and the use of intranasal corticosteroids, non-sedating antihistamines and immunotherapy. The key concepts of allergic rhinitis in children are summarized in [Box 24-4](#).

## Helpful Websites

The American Academy of Allergy, Asthma & Immunology website ([www.aaaai.org](http://www.aaaai.org))  
The American College of Allergy, Asthma and Immunology website ([www.acaai.org](http://www.acaai.org))

### BOX 24-4 KEY CONCEPTS

#### Allergic Rhinitis

- Allergic rhinitis is one of the most common chronic disorders of childhood.
- Allergic rhinitis in children is an inflammatory airway disease.
- The distinction between allergic and nonallergic forms of rhinitis is important in children.
- Treatment should be individualized, aggressive and targeted toward decreasing inflammation.
- Attention should be given to decreasing environmental exposures (e.g. allergens, tobacco smoke) and the use of intranasal corticosteroids and non-sedating antihistamines.
- Intranasal steroids constitute very effective therapy for allergic rhinitis and are safe despite a potential small drug-specific effect on growth rates.
- Allergic rhinitis in children may predispose to the development of otitis media, sinusitis and asthma.

The Journal of Allergy and Clinical Immunology website ([www.jacionline.org](http://www.jacionline.org))

The Annals of Allergy, Asthma & Immunology website ([www.annallergy.org](http://www.annallergy.org))

The complete reference list can be found on the companion Expert Consult website at <http://www.expertconsult.inkling.com>.

## KEY REFERENCES

- Blais MS, Dykewicz MS, Skoner DP, Smith N, Leatherman B, Craig TJ, et al. Diagnosis and treatment of nasal and ocular allergies: the Allergies, Immunotherapy, and Rhinoconjunctivitis (AIRS) surveys. *Ann Allergy Asthma Immunol* 2014;112:322–8.
- Bielory L, Skoner DP, Blais MS, Leatherman B, Dykewicz MS, Smith N, et al. Ocular and nasal allergy symptom burden in America: the Allergies, Immunotherapy, and Rhinoconjunctivitis (AIRS) survey. *Allergy Asthma Proc* 2014;12:211–18.
- Mallol J, Crane J, Von Mutuis E, Odhiambo J, Keil U, Stewart A, et al. The International Study of Asthma and Allergies in Childhood (ISAAC) Phase Three: a global synthesis. *Allergol Immunopathol (Madr)* 2013;41:73–85.
- Visness CM, London SJ, Daniels JL. Association of obesity with IgE levels and allergy symptoms in children and adolescents: results from the National Health and Nutrition Examination Survey 2005–2006. *J Allergy Clin Immunol* 2009;123:1163–9.
- Meltzer EO, Bukstein DA. The economic impact of allergic rhinitis and current guidelines for treatment. *Ann Allergy Asthma Immunol* 2011;106:S12–16.
- Rosenwasser LJ. Current understanding of the pathophysiology of allergic rhinitis. *Immunol Allergy Clin North Am* 2011;31:433–9.
- Scadding G. Cytokine profiles in allergic rhinitis. *Curr Allergy Asthma Rep* 2014;14:435.
- Nathan RA. Intranasal steroids in the treatment of allergy-induced rhinorrhea. *Clin Rev Allergy Immunol* 2011;41:89–101.
- Brozek JL, Bousquet J, Baena-Cagnani CE, Bonini S, Canonica GW, Casale TB, et al. Allergic Rhinitis and its Impact on Asthma (ARIA) guidelines: 2010 Revision. *J Allergy Clin Immunol* 2010;126:466–76.
- Gentile DA, Bartholow A, Valovirata E, Scadding G, Skoner D. Current and future directions in pediatric allergic rhinitis. *J Allergy Clin Immunol Pract* 2013;1:214–26.

## REFERENCES

- Wallace DV, Dykewicz MS, Bernstein DI, Blessing-Moore J, Cox L, Khan DA, et al. The diagnosis and management of rhinitis: an updated practice parameter. *J Allergy Clin Immunol* 2008;122:S1–84.
- Blaiss MS, Dykewicz MS, Skoner DP, Smith N, Leatherman B, Craig TJ, et al. Diagnosis and treatment of nasal and ocular allergies: the Allergies, Immunotherapy, and Rhinoconjunctivitis (AIRS) surveys. *Ann Allergy Asthma Immunol* 2014;112:322–8.
- Bielory L, Skoner DP, Blaiss MS, Leatherman B, Dykewicz MS, Smith N, et al. Ocular and nasal allergy symptom burden in America: the Allergies, Immunotherapy, and Rhinoconjunctivitis (AIRS) survey. *Allergy Asthma Proc* 2014;12:211–18.
- Tang EA, Matsui E, Wiesch DG, Samet JM. Epidemiology of asthma and allergic diseases. In: Adkinson NF Jr, Bochner BS, Busse WW, editors. *Middleton's Allergy: principles and practice*. 7th ed. St Louis: Mosby; 2009.
- Wright AL, Holberg CJ, Martinez FD, Halonen M, Morgan W, Taussig LM. Epidemiology of physician diagnosed allergic rhinitis in childhood. *Pediatrics* 1994;94:895–901.
- Aberg N, Engstrom I. Natural history of allergic diseases in children. *Acta Paediatr Scand* 1990;79:206–11.
- Tang RB, Tsai LC, Hwang HM, Hwang B, Wu KG, Hung MW. The prevalence of allergic disease and IgE antibodies to house dust mite in schoolchildren in Taiwan. *Clin Exp Allergy* 1990;20:33–8.
- Asher MI, Montefort S, Bjorksten B, Lai CK, Strachan DP, Weiland SK, et al. Worldwide time trends in the prevalence of symptoms of asthma, allergic rhinoconjunctivitis, and eczema in childhood: ISAAC Phases One and Three repeat multicountry cross-sectional surveys. *The Lancet* 2006;368:733–43.
- Mallol J, Crane J, Von Mutuis E, Odhiambo J, Keil U, Stewart A, et al. The International Study of Asthma and Allergies in Childhood (ISAAC) Phase Three: a global synthesis. *Allergol Immunopathol (Madr)* 2013;41:73–85.
- Visness CM, London SJ, Daniels JL. Association of obesity with IgE levels and allergy symptoms in children and adolescents: results from the National Health and Nutrition Examination Survey 2005–2006. *J Allergy Clin Immunol* 2009;123:1163–9.
- Kallimoaki M, Salminen S, Arvilommi H, Kero P, Koskinen P, Isolauri E. Probiotics in primary prevention of atopic disease: a randomised placebo-controlled trial. *The Lancet* 2001;357:1076–9.
- Heffner KL, Kiecolt-Glaser JK, Glaser R, Malarkey WB, Marshall GD. Stress and anxiety effects on positive skin test responses in young adults with allergic rhinitis. *Ann Allergy Asthma Immunol* 2014;113:13–18.
- Rutkowski K, Sowa P, Rutkowska-Talipska J, Sulkowski S, Rutkowski R. Allergic diseases: the price of civilization progress. *Postep Derm Alergol* 2014;2:77–83.
- Saadeh D, Salameh P, Bladi I, Raherison C. Diet and allergic diseases among population aged 0 to 18 years: myth or reality? *Nutrients* 2013;5:3399–423.
- Nwaru BI, Takkinen H-M, Kaila M, Erkkola M, Ahonen S, Pekkanen J, et al. Food diversity in infancy and the risk of childhood asthma and allergies. *J Allergy Clin Immunol* 2014;4:1084–90.
- Meltzer EO, Bukstein DA. The economic impact of allergic rhinitis and current guidelines for treatment. *Ann Allergy Asthma Immunol* 2011;106:S12–16.
- Raphael GD, Baraniuk JN, Kaliner MA. How and why the nose runs. *J Allergy Clin Immunol* 1991;87:457–67.
- Baraniuk J, Kaliner M. Functional activity of upper airway nerves. In: Busse W, Holgate S, editors. *Mechanisms in asthma and rhinitis: implications for diagnosis and treatment*. London: Blackwell Scientific; 1995.
- Naclerio RM. Allergic rhinitis. *N Engl J Med* 1991;325:860–9.
- Mygind N, Naclerio R. Allergic and non-allergic rhinitis. Philadelphia: WB Saunders; 1993.
- Naclerio RM, Proud D, Togias AG, Adkinson NF Jr, Meyers DA, Kagey-Sokotka A, et al. Inflammatory mediators in late antigen-induced rhinitis. *N Engl J Med* 1985;313:65–70.
- Rosenwasser LJ. Current understanding of the pathophysiology of allergic rhinitis. *Immunol Allergy Clin North Am* 2011;31:433–9.
- Scadding G. Cytokine profiles in allergic rhinitis. *Curr Allergy Asthma Rep* 2014;14:435.
- Nathan RA. Intranasal steroids in the treatment of allergy-induced rhinorrhea. *Clin Rev Allergy Immunol* 2011;41:89–101.
- Tsvetkova-Vicheva V, Konova E, Lukanov T, Gecheva S, Velkova A, Komsa-Penkova R. Interleukin-17 producing T cells could be a marker for patients with allergic rhinitis. *IMAJ* 2014;16:358–62.
- Ellis AK, Ratz JD, Day AG, Day JH. Factors that affect the allergic rhinitis response to ragweed allergen exposure. *Ann Allergy Asthma Immunol* 2010;104:293–8.
- Weber RW. Aeroallergen botany. *Ann Allergy Asthma Immunol* 2014;112:102–7.
- Kustrzeba-Wójcicka I, Siwak E, Terlecki G, Wolanczyk-Medrala A, Medrala W. *Alternaria alternata* and its allergens: a comprehensive review. *Clin Rev Allergy Immunol* 2014;31:370–4.
- Broide DH. Allergic rhinitis: pathophysiology. *Allergy Asthma Proc* 2010;31:370–4.
- Kariyawasam HH, Rotiroti G. Allergic rhinitis, chronic rhinosinusitis and asthma: unravelling a complex relationship. *Curr Opin Otolaryngol Head Neck Surg* 2013;21:79–86.
- Feng CH, Miller MD, Simon RA. The united allergic airway: connections between allergic rhinitis, asthma, and chronic sinusitis. *Am J Rhinol Allergy* 2012;26:187–90.
- Mener DJ, Lin SY, Ishman SL, Boss EF. Treatment and outcomes of chronic rhinosinusitis in children with primary ciliary dyskinesia: where is the evidence? A qualitative systematic review. *Int Forum Allergy Rhinol* 2013;3:986–91.
- Fundakowski C, Ojo R, Younis R. Rhinosinusitis in the pediatric patient with cystic fibrosis. *Current Pediatr Rev* 2014;10:198–201.
- Benoit MM, Bhattacharyya N, Faquin W, Cunningham M. Cancer of the nasal cavity in the pediatric population. *Pediatrics* 2008;121:e141–5.
- Caimmi D, Matti E, Pelizzo G, Marseglia A, Caimmi S, Labo E, et al. Nasal polyposis in children. *J Biol Regul Homeost Agents* 2012;26(Suppl. 1):S77–83.
- Settipane RA, Borish L, Peters AT. Determining the role of allergy in sinusoidal disease. *Am J Rhinol Allergy* 2013;27(Suppl. 1):S56–8.
- Dondi A, Tripodi S, Panetta V, Asero R, Businco AD, Bianchi AD, et al. Pollen-induced allergic rhinitis in 1360 Italian children: comorbidities and determinants of severity. *Pediatr Allergy Immunol* 2013;24:742–51.
- Ibáñez MD, Valero AL, Montoro J, Jaurequi I, Ferrer M, Davila I, et al. Analysis of comorbidities and therapeutic approach for allergic rhinitis in a pediatric population in Spain. *Pediatr Allergy Immunol* 2013;24:678–84.
- Hamilton RG. Clinical laboratory assessment of immediate-type hypersensitivity. *J Allergy Clin Immunol* 2010;125(2 Suppl. 2):S284–96.
- Brozek JL, Bousquet J, Baena-Cagnani CE, Bonini S, Canonica GW, Casale TB, et al. Allergic Rhinitis and its Impact on Asthma (ARIA) guidelines: 2010 Revision. *J Allergy Clin Immunol* 2010;126:466–76.
- Gentile DA, Bartholow A, Valovirata E, Scadding G, Skoner D. Current and future directions in pediatric allergic rhinitis. *J Allergy Clin Immunol Pract* 2013;1:214–26.
- Schad CA, Skoner DP. Antihistamines in the pediatric population: achieving optimal outcomes when treating seasonal allergic rhinitis and chronic urticaria. *Allergy Asthma Proc* 2008;29:7–13.
- Mygind N, Nielsen LP, Hoffman HJ, Shukla A, Blumberg G, Dahl R, et al. Mode of action of intranasal corticosteroids. *J Allergy Clin Immunol* 2001;108:S16–25.
- Szeffler SJ. Pharmacokinetics of intranasal corticosteroids. *J Allergy Clin Immunol* 2001;108:S26–31.
- Scadding GK. Corticosteroids in the treatment of pediatric allergic rhinitis. *J Allergy Clin Immunol* 2001;108:S26–31.
- Schenkel EJ, Skoner DP, Bronsky EA, Miller SD, Pearlman DS, Rooklin A, et al. Absence of growth retardation in children with perennial allergic rhinitis following 1 year of treatment with mometasone furoate aqueous nasal spray. *Pediatrics* 2000;105:E22.
- Skoner DP, Schaffner TJ, Schad CA, Kwon AY, Skoner DP. Addressing steroid phobia: improving the risk-benefit ratio with new agents. *Allergy Asthma Proc* 2008;29:358–68.
- Skoner DP, Rachelefsky GS, Meltzer EO, Chervinsky P, Morris RM, Seltzer JM, et al. Detection of growth suppression in children during treatment with intranasal beclomethasone dipropionate. *Pediatrics* 2000;105:E23.
- Pederson S. Assessing the effect of intranasal steroids on growth. *J Allergy Clin Immunol* 2001;108:S26–31.
- Storms WW, Segall N, Mansfield LE, Amar NJ, Kelley L, Ding Y, et al. Efficacy and safety of beclomethasone dipropionate nasal aerosol in pediatric patients with seasonal allergic rhinitis. *Ann Allergy Asthma Immunol* 2013;111:408–14.e1.
- Berger WE, Shah S, Lieberman P, Hadley J, Price D, Munzel U, et al. Long-term, randomized safety study of MP29-02 (a novel intranasal formulation of azelastine hydrochloride and fluticasone propionate in an advanced delivery system) in subjects with chronic rhinitis. *J Allergy Clin Immunol* 2014;2:179–85.
- Meltzer EO, Malmstrom K, Lu S, Prenner BM, Wei LX, Weinstein SF, et al. Concomitant

- montelukast and loratadine as treatment for seasonal allergic rhinitis: a randomized, placebo-controlled clinical trial. *J Allergy Clin Immunol* 2000;105:917–22.
53. Chervinsky P, Philip G, Malice MP, Bardelas J, Nayak A, Marchal JL, et al. Montelukast for treating fall allergic rhinitis: effect of pollen exposure in three studies. *Ann Allergy Asthma Immunol* 2004;92:367–73.
  54. Metzler EO, Philip G, Weinstein SF, LaForce CF, Malice MP, Dass SB, et al. Montelukast effectively treats the nighttime impact of seasonal allergic rhinitis. *Am J Rhinol* 2005;19:591–8.
  55. Patel P, Philip G, Yang W, Call R, Horak F, LaForce C, et al. Randomized, double-blind, placebo-controlled study of montelukast for treating perennial allergic rhinitis. *Ann Allergy Asthma Immunol* 2005;95:551–7.
  56. Marchisio P, Varricchio A, Baggi E, Bianchini S, Capasso ME, Toretta S, et al. Hypertonic saline is more effective than normal saline in seasonal allergic rhinitis in children. *Int J Immunopathol Pharmacol* 2012;25:721–30.
  57. Bousquet J, Demoly P, Michel FB. Specific immunotherapy in rhinitis and asthma. *Ann Allergy Asthma Immunol* 2001;87:38–42.
  58. Compalati E, Penagos M, Tarantini F, Passalacqua G, Canonica GW. Specific immunotherapy for respiratory allergy: state of the art according to current meta-analyses. *Ann Allergy Asthma Immunol* 2009;102:22–8.
  59. Maloney J, Bernstein D, Nelson H, Creticos P, Hebert J, Noonan M, et al. Efficacy and safety of grass sublingual immunotherapy tablet, MK7243: a randomized controlled trial. *Ann Allergy Asthma Immunol* 2014;112:146–53.
  60. Blaiss M, Maloney J, Nolte H, Gawchik S, Yao R, Skoner DP. Efficacy and safety of timothy grass allergy immunotherapy tablets in North American children and adolescents. *J Allergy Clin Immunol* 2011;127:64–71.
  61. Nolte H, Hebert J, Berman G, Gawchik S, White M, Kaur A, et al. Randomised controlled trial of ragweed allergy immunotherapy tablet efficacy and safety in North American adults. *Ann Allergy Asthma Immunol* 2013;110:450–6.
  62. Durham SR, Emminger W, Kapp A, de Mochy JG, Rak S, Scadding GK, et al. SQ-standardized sublingual grass immunotherapy: confirmation of disease modification 2 years after 3 years of treatment in a randomized trial. *J Allergy Clin Immunol* 2012;129:717–25.e5.
  63. Caykaytar O, Akdis CA, Akdis M. Modulation of immune responses by immunotherapy in allergic diseases. *Curr Opin Pharmacol* 2014;17C:30–7.

## KEY POINTS

- Otitis media remains an extremely common disorder; vaccination strategies are decreasing its incidence.
- Recent guidelines highlight the need for more careful diagnostic criteria.
- Initial treatment can include either initiation of antibiotics or a period of observation, depending on patient age and severity of presentation.
- Frequent otitis media is a key feature of primary immune deficiency.
- Respiratory allergy contributes to chronic otitis media with effusion (OME), but more study is needed to fully define the impact of allergy on this common condition.

## Introduction

Acute otitis media (AOM), and the related otitis media with effusion (OME), are the most common diseases requiring pediatric care in the first decade of life, except for viral upper respiratory infections. The costs of primary and specialty care, as well as the indirect costs incurred by the family, are enormous. In 2013, estimates for the direct cost of treating otitis media (OM) in the USA totaled \$ 2.88 billion, not including indirect costs.<sup>1</sup> Indirect costs incurred by families (such as hours of work lost, transportation, etc.) may equal the direct costs, doubling the financial burden.<sup>2</sup> There have been significant advances in the past 40 years in understanding of the pathogenesis, pathophysiology and immunopathology of OM, leading to a decrease in physician visits and antibiotic prescriptions for this illness.<sup>3,4</sup> Improved recognition, a willingness to observe the evolution of less severe cases and widespread pneumococcal vaccination likely have contributed to this improvement. This chapter provides a review of the epidemiology, pathogenesis, Eustachian tube (ET) physiology and immunology of OM as well as medical and surgical therapies employed to treat it. It also provides information on the potential role of allergy in the pathogenesis of this prevalent condition.<sup>3</sup>

## Definitions

OM is characterized by acute or chronic inflammation of the middle ear (ME).<sup>5</sup> AOM is typically preceded by or associated with viral upper respiratory tract infections (URTI); up to 37% of viral URIs may be complicated by OM.<sup>6</sup> Persistent OM is defined as persistence of symptoms and signs of ME infection despite antimicrobial therapy (i.e. treatment failure) and/or a relapse of AOM within 1 month of completion of antibiotic

therapy. When two episodes of OM occur within 1 month, it may be difficult to distinguish recurrence of AOM from persistent otitis media (relapse). Recurrent AOM is defined as having 3 or more episodes of AOM in 6 months or 4 episodes in 12 months (Box 25-1).<sup>7</sup>

AOM often evolves into OME, chronic middle ear effusion (MEE) without signs or symptoms of acute infection. After an episode of AOM, 60% to 70% of children have OME at 2 weeks, decreasing to 40% at 1 month and 10% to 25% at 3 months.<sup>8</sup> Chronic OME is defined as OM lasting for 12 weeks. Children with certain sensory, physical, cognitive and behavioral conditions are particularly vulnerable to the hearing loss, speech, language and learning problems associated with OME.<sup>9</sup>

## Epidemiology

The peak incidence for AOM is during the first 2 years of life, and most initial cases occur between 6 and 12 months of age.<sup>7</sup> By 1 year of age almost 50% of children have had at least one episode of AOM,<sup>10</sup> and two thirds by 3 years. Three or more episodes of OM occur in 10% of children by 1 year of age and in 33% by 3 years of age. Tos and colleagues reported a point prevalence of OME of 13% during the first 2 years of life. In 4- to 6-year-old children, point prevalence decreased to 7% and then further decreased to 2% to 4% in 8- to 10-year-old children.<sup>11-13</sup> Whereas population-based studies in the USA and Finland suggested that OM was increasing toward the end of the 20th century,<sup>14,15</sup> changes in healthcare systems, access to care, patterns of using services and awareness of OM may be partially responsible for these increases.<sup>16</sup> The widespread use of pneumococcal vaccination appears to play a positive role in reducing the overall incidence of acute OM and subsequent complications, although the effect appears to be restricted to early infancy.<sup>3,17</sup>

Multiple factors increase the risk of OM in children. The best-defined risk factor in the development of AOM is a preceding viral URTI. A prospective cohort study by Wald and colleagues reported that 25% to 40% of URIs in children from birth to 3 years of age were accompanied by an episode of AOM,<sup>18</sup> most commonly under 1 year of age.

Universally, males are affected more than females. Indigenous populations, such as North American Indians, native Canadians and Polynesian children, have a much higher incidence than white children.<sup>19</sup> Compared with bottle-feeding, breastfeeding for at least 6 months is associated with a decreased risk of acute otitis or recurrent otitis during the first year of life.<sup>20</sup> This protective effect on both the frequency of URIs and the resultant AOM may not be seen with shorter durations of breastfeeding.<sup>21-23</sup> Cigarette smoking by the parents, especially the mother, is a significant risk factor for AOM during the first year of life.<sup>24</sup> Children whose parents or siblings have had a history of chronic otitis have a higher incidence than those with



**BOX 25-1 CLASSIFICATION OF OTITIS MEDIA**

- Acute otitis media
- Recurrent acute otitis media
- Persistent acute otitis media
- Otitis media with effusion
- Chronic otitis media with effusion

**BOX 25-2 RISK FACTORS FOR OTITIS MEDIA****ENVIRONMENTAL FACTORS**

- Viral upper respiratory tract infection
- Daycare attendance
- Cigarette smoke (passive)
- Low socioeconomic status
- Environmental pollution

**HOST FACTORS**

- Male gender
- Genetic predisposition
- Premature birth
- Not breastfed
- Supine bottle-feeding
- Immune deficiency (primary and secondary)
- Craniofacial abnormalities
- Eustachian tube dysfunction
- Cilia dysfunction
- Allergic rhinitis

no family history.<sup>10</sup> A cohort study of 2,512 children in Finland concluded that, while family size, low socioeconomic status and cigarette smoking were all individually correlated with an increased risk of recurrent AOM, they were all interdependent variables. The association of these factors with AOM was best accounted for by the strong correlation with attendance at large ( $\geq 20$  children) daycare centers as well as short duration of breastfeeding.<sup>25</sup> A study of 175 sets of twins and triplets followed from birth indicated a genetic component to susceptibility to AOM. The estimate of discordance of AOM in monozygotic twins was 0.04 compared with 0.49 in dizygotic twins ( $P < .005$ ).<sup>26</sup> Numerous studies confirm an augmented risk of AOM, recurrent otitis media (ROM) and OME as the number of children in the childcare setting increases.<sup>27</sup> Other factors such as preterm birth and greater number of siblings in the household also increased a child's risk of AOM.<sup>7</sup> Specific conditions such as Down's syndrome, craniofacial anomalies,<sup>28,29</sup> ciliary dyskinesia syndromes and primary and secondary immune deficiency syndromes<sup>30-32</sup> are associated with increased risks of AOM (Box 25-2).

Using tympanometry, Mandel and Casselbrant found that asymptomatic OME is relatively frequent in daycare settings, especially in the winter months. Repeated evaluations indicated that many cases resolved spontaneously without therapy and effusions could persist for up to 6 months without overt symptoms.<sup>33</sup>

Whether allergy predisposes children to AOM and OME is an area of controversy.<sup>34</sup> Scandinavian and US studies have shown that, during the first 3 years of life, there is no association between AOM and allergic disease.<sup>35</sup> Allergy is cited as a potential risk factor for OME, especially in children needing surgical intervention. Early clinical studies suffered from significant methodologic limitations such as lack of control groups or

unclear definitions of allergy. For example, one study of children with chronic OM referred for placement of ventilation tubes found that approximately half the children had positive allergy skin tests or increased serum immunoglobulin E (IgE) antibodies to specific allergens. However, there was no comparison to normal controls, nor was it clear whether these children had clinical allergies or asymptomatic sensitization.<sup>36-38</sup> More recent studies have used prospective birth cohorts to examine the risk of OME in children with allergic disease. The COPASC cohort from Copenhagen found little effect of allergic rhinitis on OME in early life, but a strong correlation at age 6.<sup>39</sup> This was not only due to obstruction, but potentially to effects of Th2 inflammation. The LISA cohort from Germany found similar associations at age 6. They also examined if early OM predicted onset of allergic disease; they found positive correlations for late-onset atopic eczema and asthma, but not for allergic rhinitis.<sup>40</sup> Several in vitro studies substantiate a pathophysiologic link between allergy and OME.<sup>34</sup>

No association between OM and food ingestion has been found. A large unblinded trial showed some efficacy of elimination diets in OME.<sup>41</sup> One study suggested a link between IgE-mediated cow's milk allergy and recurrent otitis media, however the effect could be completely accounted for by the presence of respiratory allergies in these children.<sup>42</sup> There has been little progress and no significant peer-reviewed studies in this area in the past decade.

## Pathophysiology

### STRUCTURE AND FUNCTION

Otitis media is a disease of the upper respiratory tract. Ventilation of the ME is accomplished via the ET from the posterior nasopharynx. Middle ear effusions in children are most often related to abnormal ET function. The ET provides an anatomic communication between the nasopharynx and the ME. Like mucosa elsewhere in the respiratory tract, the ET lining contains mucus-producing cells, ciliated cells, plasma cells and mast cells.<sup>43</sup> Unlike the bronchial tree, the ET is usually collapsed and thus closed to the nasopharynx and its contents. The ET, like the bronchi, serves several physiologic functions. It protects the ME from nasopharyngeal secretions, drains secretions produced within the ME into the nasopharynx, ventilates the ME to equilibrate pressures and replenishes oxygen in the ME. In normal tubal function, intermittent opening of the ET maintains near-ambient pressure in the ME cavity. It is suspected that in cases in which active swallowing is inadequate to overcome tubal resistance, the tube remains persistently collapsed, resulting in progressively negative ME pressure. This abnormal pressure appears to be common in children. Periodic or persistently high negative pressure may be pathologic and associated with abnormal ET function and may lead to AOM.

### EUSTACHIAN TUBE OBSTRUCTION

Two types of ET obstruction, mechanical and functional, could result in acute or chronic OME (Box 25-3). Intrinsic mechanical obstruction may result from inflammation of infection or allergy, whereas extrinsic obstruction may result from enlarged adenoids or, in rare instances, nasopharyngeal tumors. Experimentally, allergic rhinitis provoked in patients with a history of allergy has been associated with the development of ET

**BOX 25-3 TYPES OF EUSTACHIAN TUBE OBSTRUCTION**

- Mechanical obstruction
  - Intrinsic
    - Infectious inflammation
    - Allergic inflammation
  - Extrinsic (peritubular)
    - Adenoidal hypertrophy
    - Nasopharyngeal tumor
- Functional obstruction
  - Poor tensor veli palatini muscle function
  - Increased tubal compliance

obstruction.<sup>44</sup> A persistent collapse of the ET during swallowing may result in functional obstruction, which appears to be related to increased tubal compliance, an inefficient, active opening mechanism by the tensor veli palatine muscle, or both. The angulation of the craniofacial base changes with age, improving the tensor veli palatine muscle after puberty. Additionally, in infants and younger children the cartilaginous support of the ET is less robust.<sup>19,45</sup>

## Pathogenesis

A role for ET dysfunction in the pathogenesis of AOM during a viral URTI is supported by multiple clinical and experimental studies. Studies reported tubal dysfunction in children and adults with natural viral URTI,<sup>46</sup> experimental infection<sup>47</sup> and animal models.<sup>48</sup>

Rhinovirus infection results in significant increases in nasal inflammation, impaired tubal function and abnormal ME pressures in more than 40% of subjects, and asymptomatic OM in approximately 2% of subjects.<sup>47</sup> These events occurred sequentially and in descending frequency, supporting a causal pathway. This pattern occurred in infection with rhinovirus, influenza A virus, and coxsackievirus A and influenza.<sup>49,50</sup> In the majority, OM was asymptomatic with experimental infection and the recovered effusion was negative by culture for viruses and bacteria but positive for influenza A and *Streptococcus pneumoniae* by polymerase chain reaction (PCR).<sup>51</sup> The inflammatory response to acute infection is a key part of the pathophysiology of the disease. Using a murine model of ME and *H. influenzae* infection, Ryan and colleagues documented that ME mucosa rapidly undergoes hypertrophy and within 24 hours exhibits edema, mucosal thickening and lymphocytic infiltrate.<sup>52</sup> This progressed over a 5- to 7-day period and resolved. Similar pathology was noted in larger animal models of AOM, including rats, guinea pigs and chinchillas.<sup>48</sup> Middle ear effusions were accompanied by inflammatory cytokines, including TNF- $\alpha$ , IL-1, IL-8, IL-10 and IL-6, which diminished over 48 to 72 hours.<sup>53,54</sup> The inflammatory infiltrate was potentiated by chemokines produced in the infectious response. What is lacking in the animal models of acute OM are experiments mimicking both early viral infection and subsequent bacterial superinfection characteristic in humans. Most models induce OM via introduction of bacteria to the ME via the tympanic membrane (TM) or the bulla (i.e. the ME in mice). While this duplicates the pathogens found within ME fluid in AOM, it does not completely mimic AOM pathogenesis. A small number of models have employed co-exposure to viruses and bacteria, primarily to assess therapeutic approaches.<sup>55-59</sup> A

novel, potentially highly important contribution of animal models is the discovery of genes that may predispose to OM. Genetic work has identified the key role of innate immunity in the inflammatory response of the ME. It is well recognized that, in addition to humoral immune defects, subtle defects in mucosal immunity such as mannose binding ligand defects render children more susceptible to OM. Using murine models, a crucial role for proteins in the Toll receptor pathways was identified.<sup>60-62</sup> MyD-88 signaling may also be crucial for defense against bacterial pathogens in AOM.<sup>54,60</sup> Indeed, defects in chemokines such as IL-8, MCP-1 and CCL3, which play integral roles in promoting early neutrophilic inflammation,<sup>63-65</sup> can predispose animals to AOM.<sup>66</sup> In contrast, deleting CCR5 can ameliorate the severity of bacterial OM.<sup>57</sup>

The role of mast cells and innate immune responses in AOM has been the subject of multiple studies. Mast cells, as primarily mucosal leukocytes, are the most common hematopoietic cells found in the normal ME, including the lining of the ME, ET and the TM. This has led to a focus on allergy in the pathogenesis of otitis. However, it is unlikely that the primary role of the mast cell in OM is via its ability to bind IgE on Fc $\epsilon$ R1, but rather its role in binding IgG via Fc gamma receptors. In *cKit* knockout mice, which are unable to produce mast cells, infection induced into the ME did not cause inflammation, mucosal changes or remodeling found in mast cell sufficient mice or *cKit* knockout mice that had received infusions of normal mast cells.<sup>67</sup> ME fluid harbors mast cell mediators in both acute and chronic models of OM, underlining the role of mast cells in the normal host response against bacteria.<sup>68</sup>

Another major advantage of the expanding role of murine models is the ability to detect new genes that may predispose to OM. Defects that affect the development of ET and ME include mutations in the transcription factor EVI1 and the eyes absent homolog *Eya1*.<sup>69-71</sup> A mouse model of deafness known to develop chronic suppurative OM, Jeff, carries a mutation in an F-box gene, *Fbxo11*, predisposing to development of cleft palate.<sup>72-74</sup> Even well-known genetic syndromes such as DiGeorge/velocardiofacial syndrome have been advanced in the study of OM pathogenesis by murine models.<sup>75</sup> This is complemented by genome wide association studies in several cohorts of human subjects that identified predisposing single nucleotide polymorphisms in innate immune pathways such as IL-1 $\beta$  and CXCR3R1.<sup>76,77</sup>

## Etiology

### ACUTE OTITIS MEDIA AND OTITIS MEDIA WITH EFFUSION

Bacteria are found in approximately 60% to 70% of children with AOM who undergo tympanocentesis.<sup>78</sup> Historically, *Streptococcus pneumoniae*, *Moraxella catarrhalis* and nontypable *H. influenzae* were the predominant causative bacteria in AOM. Group A  $\beta$ -hemolytic *Streptococcus*, *Staphylococcus aureus* and, more rarely, anaerobes, account for a minority of cases. Viruses alone are recovered from ME fluid in about 15% of cases.<sup>79,80</sup> Since the routine institution of the heptavalent pneumococcal conjugate vaccine (PCV7), the microbiology of AOM has changed (Table 25-1). About 50% of children requiring myringotomy for AOM refractory to second-line antimicrobial treatment had positive cultures, most growing organisms such as *S. pneumoniae*, *Staph. aureus* and coagulase negative

**TABLE 25-1**  
**Bacteria Cultured from Middle Ear Effusion Tympanocentesis of Acute Otitis Media**

Bacteria	Percentage
<i>Haemophilus influenzae</i>	51
<i>Streptococcus pneumoniae</i>	38
<i>Moraxella catarrhalis</i>	12
<i>Staphylococcus aureus</i>	5
Two pathogens	12
No growth	30

*Staphylococcus*.<sup>81</sup> Finnish and US trials have demonstrated that PCV7 has resulted in a 6% overall reduction in the clinical incidence of AOM<sup>82</sup> which may diminish ROM and the need for tympanostomy tube placement.<sup>83,84</sup> The majority of the effect is in younger children, while children who were vaccinated later in life had less effect from PCV7.<sup>17</sup> Studies with more extensive vaccine coverage will be highly instructive in determining if there is a broader effect; in terms of healthcare dollars, 5% to 6% difference has significant impact.<sup>17</sup>

Penicillin-resistant *S. pneumoniae* is a significant clinical problem and is found in up to two thirds of pneumococcal isolates.<sup>85</sup> Approximately 50% of *H. influenzae* and 90% of *M. catarrhalis* strains produce  $\beta$ -lactamase, making them resistant to amoxicillin. Additionally, while antibiotic prescriptions for AOM have decreased somewhat, there is an increase in treatment of OM with broad-spectrum antibiotics including single-dose third-generation cephalosporins. This may well impact antibiotic resistance patterns.<sup>86</sup>

Previously it had been assumed, incorrectly, that chronic middle ear fluid (MEF) effusions were sterile. In several studies, about 50% of the chronic, persistent ME effusions had positive cultures for bacteria whose microbiology was similar to that found in acute otitis.

## Mediators of Allergy and Otitis Media with Effusion

Studies have focussed on analysis of the inflammatory infiltrate found in MEEs from OME. There is no uniform infiltrate; both Th1 and Th2 inflammation have been found in analyses of ME fluid.<sup>87</sup> MEEs with infiltrates characteristic of allergic inflammation have been studied in detail. Eosinophilia and proteins derived from eosinophil degranulation are unique features of ME disease in allergic patients.<sup>88</sup> Statistically significant differences in major basic protein and IL-5 mRNA were found in ME biopsy specimens, suggesting both eosinophil recruitment and degranulation in the ME. Elevated levels of IL-4, mast cell-derived tryptase, eosinophilic cationic protein and RANTES (regulated upon activation normal T cell-expressed and secreted) were all found in higher concentration in children with atopic backgrounds compared with nonatopic children.<sup>89</sup>

Using a cohort of 75 children skin tested prior to surgery for OME, Sobol and colleagues<sup>90</sup> and Nguyen and colleagues<sup>91,92</sup> studied cellular components and cytokine expression in MEEs of patients undergoing tympanostomy tube insertion. The incidence of atopy (positive skin tests to at least one of 12 common allergens) in these three studies was 24% to 30%. Atopic children had significantly higher levels of eosinophils, T

lymphocytes, and IL-4<sup>+</sup> and IL-5<sup>+</sup> cells on immunohistochemistry compared with the nonatopic group, and a trend toward higher mast cells and basophils. Nonatopics had higher IFN- $\gamma$  cells.<sup>90</sup> Th2 cells and cytokines were found in ME fluid in atopic children and in biopsy specimens from adenoid tissue and the torus tubarius, demonstrating a strong correlation between allergic inflammation in MEE and the upper airway.<sup>91,92</sup> A UK study with an incidence of atopy of 7% defined four groups of children with OME based on their MEE infiltrate and cytokine profiles.<sup>87,93</sup> Two groups were predominantly Th1 (subacute and chronic), one had Th1-Th2 overlap, and one was strongly Th2. A strong correlation between mucin production and the Th2 cytokines IL-4 and IL-13 was observed.

## Diagnosis of Otitis Media

### ACUTE OTITIS MEDIA

The American Academy of Pediatrics (AAP) and American Academy of Family Physicians released clinical practice guidelines in 2013 outlining the diagnosis of AOM.<sup>7</sup> The guidelines stipulate three criteria that must be fulfilled. There must be acute, abrupt onset of signs and symptoms of AOM such as otalgia, otorrhea, irritability and fever. There also must be a documented MEE. One can document this on examination of the ME by noting one of the following: a bulging TM, an air-fluid level behind the TM, otorrhea, or limited TM mobility on tympanometry, pneumatic otoscopy or acoustic reflectometry. The patient must also have signs or symptoms of inflammation in the ME, such as distinct erythema of the TM. However, crying and/or fever can both result in an erythematous TM.<sup>94,95</sup> The diagnosis of AOM is often difficult in infants who are too young to clearly express themselves. They often have co-existing viral URTI, and it is often a challenge to clear the external ear canal of cerumen. The ultimate management of the infant or child will differ depending on the physician's degree of certainty of the diagnosis of AOM. The most recent guidelines also differentiate between children who are under 24 months and older children and classify AOM as mild, moderate or severe, based on visualization of the tympanic membrane and pneumatic otoscopy.<sup>7</sup> These stricter criteria may assist in decreasing unnecessary antibiotic prescriptions.

### CHRONIC OTITIS MEDIA WITH EFFUSION

The AAP, American Academy of Family Physicians, and American Academy of Otolaryngology and Head and Neck Surgery developed clinical practice guidelines describing the diagnosis and management of OME in children.<sup>7</sup> According to these evidence-based guidelines, during follow-up of all children with OME, it is important to document the laterality, duration of effusion and presence and severity of any associated symptoms at each clinical assessment. The presence of OME can be confirmed by a combination of visual inspection, tympanometry and pneumatic otoscopy. Children at 'high risk' for development of speech, language or learning problems as a result of MEE causing hearing loss should be promptly evaluated and may need more timely surgical intervention than low-risk children. A low-risk child with OME can be managed with watchful waiting for 3 months from the onset of the effusion (if known), or from the date of diagnosis. All children with OME lasting >3 months should have a hearing test and be reexamined at 3- to

6-month intervals until the effusion is no longer present, significant hearing loss is identified or structural abnormalities of the eardrum or ME are suspected<sup>9,95</sup> (Figure 25-1).

## CHRONIC OTITIS MEDIA AND ALLERGY

Some children presenting with OM have associated rhinitis. If chronic, it is important to determine whether this rhinitis is infectious or allergic. Prolonged, perennial or recurrent seasonal rhinitis with itching and sneezing suggests an allergic basis, as does co-existent allergic conjunctivitis. A family history of allergy and/or a personal history of atopic dermatitis, allergic asthma and food allergies also raise clinical suspicion of allergic rhinitis.

It is advisable that children with persistent OME be screened for allergic rhinitis by taking a clinical history addressing symptoms, signs and timing for allergic rhinitis. If this is suspected, these children should be referred to a specialist in allergy for further evaluation and investigations.<sup>39</sup> Skin prick testing is preferred to serologic anti-IgE antibody tests for the detection of IgE antibodies to specific inhalant allergens because of the increased clinical sensitivity and lower cost. For either test result to be considered clinically relevant there must be

a correlation between exposure to a particular allergen and clinical symptoms. Total serum IgE levels are not useful, as they do not define specific allergen sensitivities.

## DIAGNOSTIC TECHNIQUES

### Physical Findings

Otoscopic inspection requires visualization of the TM. The normal TM is thin, translucent, neutrally positioned and mobile. The bony ossicles, particularly the malleus, are generally visible through the TM. Adequate assessment requires that the physician take note of the TM's thickness, degree of translucency, position and its mobility to applied pressure. A bulging eardrum and air bubbles or air-fluid levels indicate the presence of excessive ME fluid and document effusion. Various degrees of bulging may assist in better classifying the severity of the illness, whereas hyperemia and erythema alone without fluid or indications of pressure changes are much less sensitive indicators.<sup>7</sup> The ear canal may be filled with pus which, when removed, will usually reveal an inflamed TM with perforation (Figure 25-2).

Children with AOM may also have co-existent sinusitis as a complication of a viral URTI. It is also important to be aware

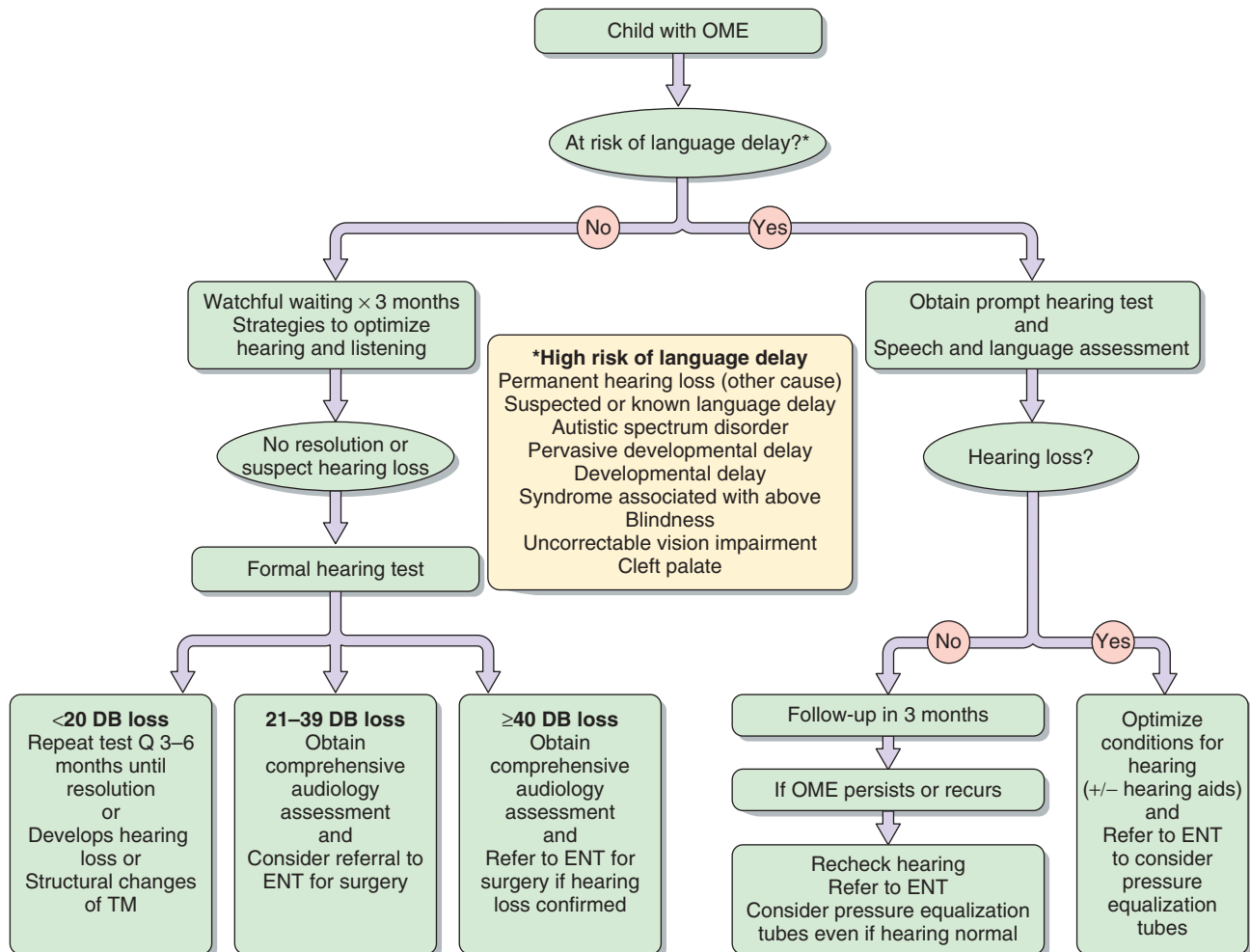

**Figure 25-1** Algorithm for management of otitis media with effusion. (Modified from Mandel EM, Casselbrant ML. Acute otitis media in decision making. In: Alper CM, Myers EN, Eibling DE, editors. Ear, nose, and throat disorders. Philadelphia: WB Saunders; 2001.)



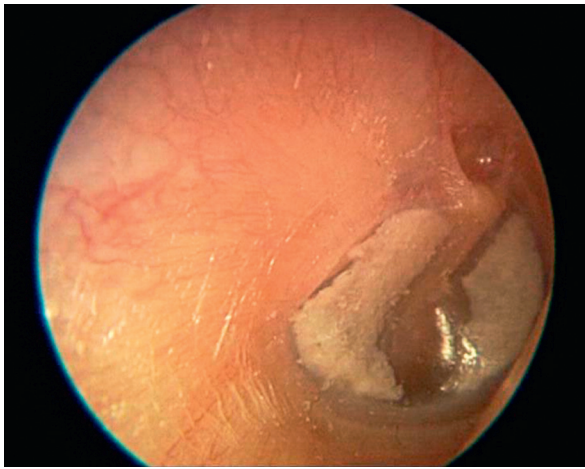

**Figure 25-2** Demonstration of acute otitis media with effusion.

of more severe, acute complications of AOM. These include co-existent mastoiditis, meningitis, brain abscess, sepsis and/or bacteremia. These complications are more likely to arise in children with underlying ME malformations, cochlear implants and immunodeficiency. One long-term complication of neglected otitis with recurrent inflammation is the development of a cholesteatoma, a cyst-like mass with a lining of stratified squamous epithelium filled with desquamating debris, which can predispose to infectious complications and hearing loss. Other long-term complications include hearing loss, tympanosclerosis and vestibular problems.<sup>96</sup>

#### *Pneumatic Otoscopy*

Clinicians should use pneumatic otoscopy as a diagnostic method for OME.<sup>7,97</sup> A meta-analysis showed that, when done by trained observers, pneumatic otoscopy has a sensitivity of 87% and specificity of 74%.<sup>98</sup> Choosing the correct size of speculum to fit the patient's ear canal and obtaining a good pneumatic seal during an otoscopic examination both help to ascertain the motility of the tympanic membrane. The loss of normal movement of the eardrum during the gentle application of air pressure via a hand-held bulb indicates a loss of compliance of the eardrum. This may be seen with either an ME effusion or increased stiffness from scarring or thickening of an inflamed eardrum.

#### *Tympanometry*

When otoscopic findings are unclear or otoscopy is difficult to perform, tympanometry can be useful in evaluating children older than 4 months.<sup>99</sup> This instrument, which measures the compliance of the eardrum as well as ME pressure, is also helpful in clinical practice in confirming the diagnosis of OME. Unlike pneumatic otoscopy, which requires clinicians to be specifically trained in order for it to be an accurate tool, tympanometry is technically straightforward with better diagnostic accuracy.<sup>9</sup>

#### *Audiogram*

An audiogram to evaluate for conductive hearing deficit is necessary for the management of recurrent and chronic OME. OME is most often associated with conductive hearing loss of about 25 to 30 dB, directly attributable to the effects of fluid in the ME.<sup>100–102</sup>

## DIAGNOSIS OF IMMUNODEFICIENCY SYNDROMES

The possibility of an immunodeficiency syndrome should be considered if a child has an increased susceptibility to infections. One consensus statement suggests that eight or more diagnosed episodes of AOM should raise suspicion for an underlying immunodeficiency. The combination of multiple episodes of AOM, accompanied by recurrent sinusitis, pneumonia or other infections, warrants a formal immunologic assessment (see [www.info4pi.org](http://www.info4pi.org)).

The initial laboratory tests performed should include a complete blood count and leukocyte differential to ensure that there is no underlying lymphopenia or neutropenia. Defects of humoral immunity most often present with recurrent oto-sino-pulmonary infections.<sup>103</sup> Thus, the quantification of serum immunoglobulins including IgG, IgA, IgM and IgE is indicated. It is also mandatory to assess the child's response to vaccines (diphtheria, tetanus, *H. influenzae* type B, *Pneumococcus*) to determine the child's capacity to mount an immune response and sustain immunologic memory.<sup>104,105</sup> If the initial work-up is unremarkable, but one still suspects an underlying immunodeficiency, second-line investigations can be considered. Defects in the innate barrier system, such as inner ear malformations, implanted foreign bodies, cystic fibrosis and primary ciliary dyskinesia, can all lead to recurrent AOM. B and T lymphocyte enumeration by flow cytometry or lymphocyte proliferation assay may also be indicated. While recurrent AOM is unlikely to be the only presenting symptom of an early-component complement deficiency, depending on associated clinical features, levels of C3, C4, mannose binding ligand and total hemolytic complement can be measured.<sup>106</sup> Less common conditions that can also predispose to recurrent oto-sino-pulmonary infections include specific polysaccharide antibody deficiency<sup>105</sup> and IRAK-4 deficiency (a defect in signaling through Toll-like receptors).<sup>107,108</sup> A large variety of B cell defects have been recently characterized genetically, and recurrent ear and sinus infections are important components of these humoral immune defects.<sup>109</sup> Defects in cell-mediated immunity, both primary and secondary (such as HIV), can also predispose patients to have recurrent AOM.

## Treatment

### ACUTE OTITIS MEDIA

The therapy for AOM is outlined in [Figure 25-3](#). If there are no potential or documented complications, the initial management consists of treating associated pain and deciding if antibiotics are indicated. Several meta-analyses have found that OM resolves without antibiotics in 80% of children over 2 years old and in 30% of children younger than 2 years of age.<sup>110,111</sup> In children under the age of 2, two large placebo-controlled trials of amoxicillin-clavulanate or placebo clearly demonstrated more rapid resolution and decrease of symptoms with antibiotics compared to placebo.<sup>112,113</sup> Thus, the decision to institute therapy or continue observation is clearly dependent on age, and these studies and others led to modifications of recent guidelines.

Antibiotics should continue to be provided as first-line therapy for children with clear visual signs of otitis media, moderate or severe otalgia and fever  $\geq 39^{\circ}\text{C}$ . An AAP

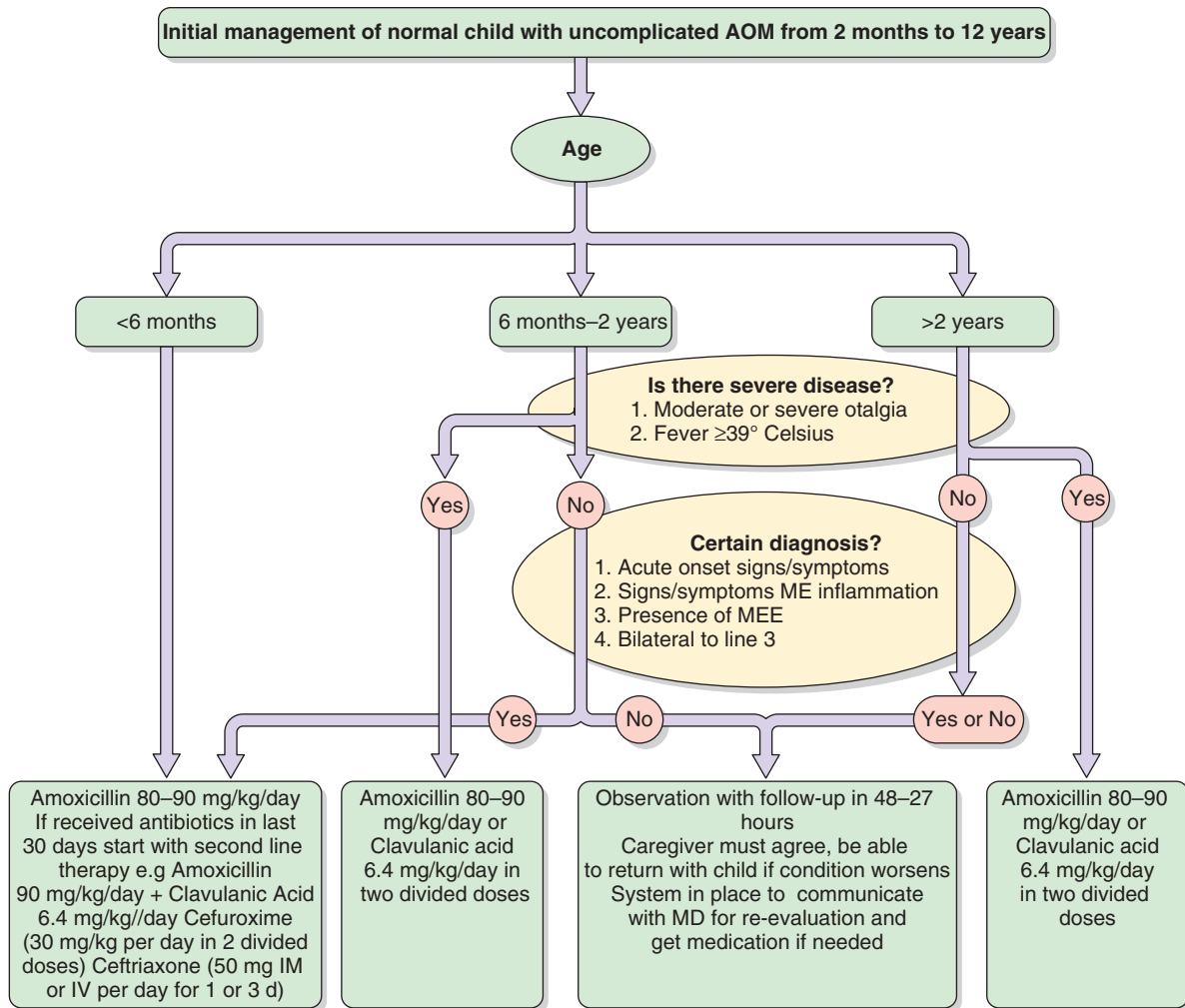

**Figure 25-3** Algorithm for management of acute otitis media.

subcommittee review recommended that selected patients can be managed with ‘observation only’ providing pain control without antibacterial treatment for 48 hours, in consultation with the caregiver, and as long as follow-up is ensured. This is not an option in patients with known or suspected immunodeficiencies, infants under 6 months of age and children presenting with severe disease (moderate-severe otalgia or fever  $>39^{\circ}\text{C}$ ). This option can be considered for children older than 2 years of age without severe disease or uncertain diagnosis. For children aged 6 to 24 months with an uncertain diagnosis of AOM and non-severe disease, observation can be considered only if good follow-up is ensured, otherwise antibiotic therapy may be preferable.<sup>7</sup> If symptoms worsen on follow-up, the patient should then be treated with antibiotics.

In keeping with the findings of Hoberman and Tahtinen,<sup>112,113</sup> a large meta-analysis found that if a child is younger than 2 years of age with bilateral acute OM, they are more likely to ‘fail’ the ‘observation only’ option and eventually require antibiotics. In this trial 55% of children in the ‘observation only’ group versus 30% of children treated initially with antibiotics still had pain, fever or both on days 3 to 7 after diagnosis.<sup>114</sup> There does not appear to be an increase in severe complications such as mastoiditis, bacteremia or meningitis with this approach.

According to treatment guidelines, the majority of children with AOM who require antibiotics should receive amoxicillin 80–90 mg/kg/day + Clavulanic Acid 6.4 mg/kg/day. Amoxicillin is considered first-line therapy because it covers strains of *S. pneumoniae* that are both sensitive and intermediately resistant to penicillin and it has a narrow microbiologic spectrum. High-dose amoxicillin-clavulanate (80–90 mg/kg/day) is preferred for severe illness (moderate to severe otalgia and/or fever  $>39^{\circ}\text{C}$ ) in order to cover  $\beta$ -lactamase-producing *H. influenzae* and *M. catarrhalis*. In penicillin-allergic patients, azithromycin, clarithromycin or trimethoprim-sulfamethoxazole are potential alternatives. A recent practice parameter from the Joint Council of Allergy, Asthma and Immunology stated that ‘cephalosporin treatment of patients with a history of penicillin allergy, selecting out those with severe reaction histories, show a reaction rate of 0.1%’. They recommend a cephalosporin in cases without severe and/or recent penicillin allergy reaction history when skin test is not available.<sup>115</sup>

Antimicrobials should be prescribed for 10 days in children younger than 6 years and for 5 to 7 days in children over 6 years of age.<sup>7</sup>

In the event of no clinical improvement within 48 to 72 hours, the child should be re-evaluated. The physician should

ensure that the patient does not present signs of complications of AOM and reassess if the patient still meets diagnostic criteria for AOM. If the diagnosis of AOM is maintained, and the patient was initially observed, antibiotics should be prescribed. A patient initially treated with amoxicillin should be switched to amoxicillin-clavulanate. If the patient fails to respond to second-line antibiotics, one to three daily doses of parenteral ceftriaxone may be given. If this too fails, therapeutic and diagnostic tympanocentesis should be done. A culture of the ME fluid can help tailor antimicrobial therapy. In the case of penicillin-allergic patients, clindamycin is the optimal second-line therapy. When a patient has had an episode of AOM in the previous 30 days, a second-line antibiotic should be prescribed initially because the causative organism is more likely to be penicillin resistant. When symptoms of the acute infection improve, the patient should be scheduled for follow-up in 4 to 6 weeks to determine if OME persists. If OME is present at follow-up, the clinician should consider follow-up, audiology testing and, if necessary, tympanostomy on a case-by-case basis (see Figure 25-3).

Antimicrobial prophylaxis for recurrent acute OM, usually with trimethoprim-sulfamethoxazole, has demonstrated efficacy, but because of the problem of increased bacterial resistance, this therapy should be limited to selected cases.<sup>103</sup> Data from a recent Cochrane review do not support the use of decongestant treatment in children with AOM, given the lack of benefit and increased risk of side-effects.<sup>116</sup>

## OTITIS MEDIA WITH EFFUSION

OME may be a complication of AOM or it may be detected as an occult condition without previous signs or symptoms of an infection. OME is frequently asymptomatic but may cause a hearing loss or balance disturbance.<sup>117</sup> If the patient is identified as not at 'high risk' of suffering language or developmental delay as a result of hearing loss secondary to OME, the OME has been present for less than 3 months, and the patient is asymptomatic, then the patient should be re-examined at 4 to 6 weeks to determine whether the effusion has resolved. An effusion that persists for longer than 3 months should prompt a hearing evaluation with audiometry. A normal audiogram for at least one ear is reassuring and the patient can then be rechecked periodically. This watchful waiting strategy is employed because up to 90% of OME will resolve spontaneously after 3 months.<sup>94</sup> Children should have scheduled pediatric follow-up every 3 to 6 months, verifying if hearing is normal and the tympanic membrane examination free of pathology such as retraction pockets, atelectasis or cholesteatoma. Children with moderate (>40 dB) hearing loss should be referred for consideration of surgery, whereas low-risk children with mild hearing loss can continue to be observed with close follow-up and strategies to optimize hearing, such as minimizing background noise and standing close to the child when speaking.<sup>102</sup>

In patients with OME in whom persistent nasal obstruction is documented, allergy should be considered. If allergic rhinitis is documented in association with OME, management should include intranasal corticosteroids and avoidance of offending allergens. Antihistamine therapy and decongestants alone have been proven to be ineffective for OME in multiple meta-analyses,<sup>116</sup> as have antibiotics for treatment of asymptomatic OME.<sup>118</sup> Oral steroids are not recommended for the management of chronic OME or recurrent OM, and the risks of

systemic steroids largely outweigh any potential short-term benefits.<sup>119</sup>

There are no placebo-controlled trials that document the efficacy of immunotherapy for reducing the frequency or promoting the resolution of OME. Recently, a community-based ENT practice examined the effect of treating patients who warranted pressure equalization (PE) tubes for OME with immunotherapy. Although this study strongly supported the use of immunotherapy in the treatment of subjects with OME, there were methodologic problems with the evaluation and treatment of the subjects.<sup>120</sup> Similar methodologic issues were found in an older pediatric otolaryngologic study.<sup>121</sup>

In some cases of OME, surgical management is indicated. The surgical management of OME includes the insertion of tympanostomy tubes, also known as ventilation tubes or pressure equalization (PE) tubes, to promote drainage of persistent unresolved effusions and improve hearing. According to the AAP guidelines on management of OME, the indications for consultation with an otolaryngologist to consider insertion of tympanostomy tubes include OME lasting 4 months or longer with persistent hearing loss, recurrent or persistent OME in high-risk children regardless of hearing status, and OME associated with structural damage to the TM or ME. The decision of whether or not to proceed to surgery should be individualized. Children with OME of any duration who are at 'high risk' of language delay are candidates for earlier surgery.<sup>8</sup> Other plausible indications for referral include the following: (1) appropriate medical management has not been successful in alleviating the OME; (2) recurrent OME (three or more episodes in the preceding 6 months); (3) OME persisting for more than 6 months; (4) documented persistent conductive hearing loss.<sup>94</sup>

There continues to be a great deal of controversy regarding the indications for PE tube placement in children with OME. One must weigh the benefits of PE tube placement against the risks of surgery, including mortality with anesthesia and TM perforation. While PE tubes decrease by about half the number of days per year that children have OME, hearing improves only minimally (about 10 dB).<sup>100</sup> A third of children have relapse of OME after their PE tubes fall out, and later require repeated PE tube placement. Furthermore, low-risk children with longstanding OME and hearing loss derived no benefit from the insertion of PE tubes, and only one RCT has shown minimal improvement with PE tube placement in children with OME and hearing loss that resulted in disruptions of speech, language, learning or behavior.<sup>100,122</sup>

## Conclusions

Otitis media is a multifactorial illness that affects many children. It may be an acute, chronic or recurrent disease. The roles of infection, ET obstruction, allergy and host defense defects have been delineated. Infection and ET obstruction are the principal contributing factors in acute OM. However, in a child who has clinically significant allergic rhinitis, the role of allergy in chronic or recurrent OM cannot be ignored. Clinicians should be diligent about using the available tools and most recent evidence-based techniques when diagnosing AOM and OME, and not hesitate to involve consultants such as allergist-immunologists, otolaryngologist and audiologists when clinically indicated. In treating patients with OM, being mindful of indications for treatment, considering the adverse effects

of various therapies, treating associated co-morbidities, and identifying children at risk for language delays reduce the healthcare costs as well as increasing the wellbeing of these children (Box 25-4).

#### ACKNOWLEDGMENTS

I would like to thank Dr Phillip Fireman for allowing me to incorporate portions of his excellent original chapter on otitis media into this work.

I would like to thank Dr Sam Daniel, Otorhinolaryngologist at the McGill University Health Care Center for his expertise and help with this chapter.

 The complete reference list can be found on the companion Expert Consult website at <http://www.expertconsult.inkling.com>.

#### BOX 25-4 KEY CONCEPTS

##### Otitis Media

- Acute otitis media, a frequent multifactorial illness of early childhood, can evolve into a chronic otitis media with effusion associated with obstruction of the Eustachian tube.
- Viral upper respiratory infection often precedes acute otitis media, with bacteria cultured in 70% of patients with acute otitis media and 50% of patients with otitis media with effusion.
- Chronic otitis media with effusion of more than 3 months' duration promotes a conductive hearing deficit with potential resultant speech pathology.
- Increased frequency of bacterial resistance to antibiotics requires judicious selection of antibiotics without excessive use.
- Epidemiologic and experimental studies suggest a role for allergic rhinitis in the patient with chronic otitis media with effusion and nasal obstruction but not in acute otitis media.

#### KEY REFERENCES

- Lieberthal AS, Carroll AE, Chonmaitree T, Ganiats TG, Hoberman A, Jackson MA, et al. The diagnosis and management of acute otitis media. *Pediatrics* 2013;131:e964–99.
- Rosenfeld RM, Kay D. Natural history of untreated otitis media. *Laryngoscope* 2003; 113:1645–57.
- Fortanier AC, Venekamp RP, Boonacker CW, Hak E, Schilder AG, Sanders EA, et al. Pneumococcal conjugate vaccines for preventing otitis media. *Cochrane Database Syst Rev* 2014;4:CD001480.
- Lack G, Caulfield H, Penagos M. The link between otitis media with effusion and allergy: a potential role for intranasal corticosteroids. *Pediatr Allergy Immunol* 2011;22:258–66.
- Bluestone CD. Impact of evolution on the eustachian tube. *Laryngoscope* 2008;118: 522–7.
- Li JD, Hermansson A, Ryan AF, Bakaletz LO, Brown SD, Cheeseman MT, et al. Panel 4: Recent advances in otitis media in molecular biology, biochemistry, genetics, and animal models. *Otolaryngol Head Neck Surg* 2013; 148(Suppl. 4):E52–63.
- Nokso-Koivisto J, Chonmaitree T, Jennings K, Matalon R, Block S, Patel JA. Polymorphisms of immunity genes and susceptibility to otitis media in children. *PLoS ONE* 2014;9:e93930.
- Hawker JI, Smith S, Smith GE, Morbey R, Johnson AP, Fleming DM, et al. Trends in antibiotic prescribing in primary care for clinical syndromes subject to national recommendations to reduce antibiotic resistance, UK 1995–2011: analysis of a large database of primary care consultations. *J Antimicrob Chemother* 2014;39:3423–30.
- Tewfik TL, Mazer B. The links between allergy and otitis media with effusion. *Curr Opin Otolaryngol Head Neck Surg* 2006;14:187–90.
- Marchisio P, Chonmaitree T, Leibovitz E, Lieberthal A, Lous J, Mandel E, et al. Panel 7: Treatment and comparative effectiveness research. *Otolaryngol Head Neck Surg* 2013; 148(Suppl. 4):E102–21.
- Bousfiha AA, Jeddane L, Ailal F, Al Herz W, Conley ME, Cunningham-Rundles C, et al. A phenotypic approach for IUIS PID classification and diagnosis: guidelines for clinicians at the bedside. *J Clin Immunol* 2013;33:1078–87.



## REFERENCES

- Ahmed S, Shapiro NL, Bhattacharyya N. Incremental health care utilization and costs for acute otitis media in children. *Laryngoscope* 2014;124:301–5.
- Capra AM, Lieu TA, Black SB, Shinefield HR, Martin KE, Klein JO. Costs of otitis media in a managed care population. *Pediatr Infect Dis J* 2000;19:354–5.
- Grijalva CG. Decrease in antibiotic use, an added benefit of PCVs. *Lancet Infect Dis* 2014;14:175–7.
- Grijalva CG, Nuorti JP, Griffin MR. Antibiotic prescription rates for acute respiratory tract infections in US ambulatory settings. *JAMA* 2009;302:758–66.
- Revai K, Dobbs LA, Nair S, Patel JA, Grady JJ, Chonmaitee T. Incidence of acute otitis media and sinusitis complicating upper respiratory tract infection: the effect of age. *Pediatrics* 2007;119:e1408–12.
- Winther B, Doyle WJ, Alper CM. A high prevalence of new onset otitis media during parent diagnosed common colds. *Int J Pediatr Otorhinolaryngol* 2006;70:1725–30.
- Lieberthal AS, Carroll AE, Chonmaitee T, Ganiats TG, Hoberman A, Jackson MA, et al. The diagnosis and management of acute otitis media. *Pediatrics* 2013;131:e964–99.
- Rosenfeld RM, Kay D. Natural history of untreated otitis media. *Laryngoscope* 2003;113:1645–57.
- Rosenfeld RM, Culpepper L, Doyle KJ, Grundfast KM, Hoberman A, Kenna MA, et al. Clinical practice guideline: Otitis media with effusion. *Otolaryngol Head Neck Surg* 2004;130(Suppl. 5):S95–118.
- Teele DW, Klein JO, Rosner B. Epidemiology of otitis media during the first seven years of life in children in greater Boston: a prospective, cohort study. *J Infect Dis* 1989;160:83–94.
- Stangerup SE, Tos M. Epidemiology of acute suppurative otitis media. *Am J Otolaryngol* 1986;7:47–54.
- Stangerup SE, Tos M, Arnesen R, Larsen P. A cohort study of point prevalence of eardrum pathology in children and teenagers from age 5 to age 16. *Eur Arch Otorhinolaryngol* 1994;251:399–403.
- Tos M. Epidemiology and natural history of secretory otitis. *Am J Otol* 1984;5:459–62.
- Joki-Erkila VP, Laippala P, Pukander J. Increase in paediatric acute otitis media diagnosed by primary care in two Finnish municipalities – 1994–5 versus 1978–9. *Epidemiol Infect* 1998;121:529–34.
- Lanphear BP, Byrd RS, Auinger P, Hall CB. Increasing prevalence of recurrent otitis media among children in the United States. *Pediatrics* 1997;99:E1.
- Rovers MM, Schilder AG, Zielhuis GA, Rosenfeld RM. Otitis media. *Lancet* 2004;363:465–73.
- Fortanier AC, Venekamp RP, Boonacker CW, Hak E, Schilder AG, Sanders EA, et al. Pneumococcal conjugate vaccines for preventing otitis media. *Cochrane Database Syst Rev* 2014;4:CD001480.
- Wald ER, Guerra N, Byers C. Upper respiratory tract infections in young children: duration of and frequency of complications. *Pediatrics* 1991;87:129–33.
- Bluestone CD, Hebda PA, Alper CM, Sando I, Buchman CA, Stangerup SE, et al. Recent advances in otitis media. 2. Eustachian tube, middle ear, and mastoid anatomy; physiology, pathophysiology, and pathogenesis. *Ann Otol Rhinol Laryngol Suppl* 2005;194:16–30.
- Abrahams SW, Labbok MH. Breastfeeding and otitis media: a review of recent evidence. *Curr Allergy Asthma Rep* 2011;11:508–12.
- Chantray CJ, Howard CR, Auinger P. Full breastfeeding duration and associated decrease in respiratory tract infection in US children. *Pediatrics* 2006;117:425–32.
- Kramer MS, Chalmers B, Hodnett ED, Sevkovskaya Z, Dzvikovich I, Shapiro S, et al. Promotion of Breastfeeding Intervention Trial (PROBIT): a randomized trial in the Republic of Belarus. *JAMA* 2001;285:413–20.
- Kuiper S, Muris JW, Dompeling E, Kester AD, Wesseling G, Knottnerus JA, et al. Interactive effect of family history and environmental factors on respiratory tract-related morbidity in infancy. *J Allergy Clin Immunol* 2007;120:388–95.
- Jacoby PA, Coates HL, Arumugaswamy A, Elsbury D, Stokes A, Monck R, et al. The effect of passive smoking on the risk of otitis media in Aboriginal and non-Aboriginal children in the Kalgoorlie-Boulder region of Western Australia. *Med J Aust* 2008;188:599–603.
- Alho OP, Koivu M, Sorri M, Rantakallio P. Risk factors for recurrent acute otitis media and respiratory infection in infancy. *Int J Pediatr Otorhinolaryngol* 1990;19:151–61.
- Casselbrant ML, Mandel EM, Fall PA, Rockette HE, Kurs-Lasky M, Bluestone CD, et al. The heritability of otitis media: a twin and triplet study. *JAMA* 1999;282:2125–30.
- Daly KA, Casselbrant ML, Hoffman HJ, Ingvarsson LB, Kvaerner KJ, Tos M, et al. Recent advances in otitis media. 2. Epidemiology, natural history, and risk factors. *Ann Otol Rhinol Laryngol Suppl* 2002;188:19–25.
- Bluestone CD. Studies in otitis media: Children's Hospital of Pittsburgh-University of Pittsburgh progress report – 2004. *Laryngoscope* 2004;114(11 Pt 3 Suppl. 105):1–26.
- Clarke RW. Ear, nose and throat problems in children with Down syndrome. *Br J Hosp Med (Lond)* 2005;66:504–6.
- Boyle RJ, Le C, Balloch A, Tang ML. The clinical syndrome of specific antibody deficiency in children. *Clin Exp Immunol* 2006;146:486–92.
- Wilson NW, Hogan MB. Otitis media as a presenting complaint in childhood immunodeficiency diseases. *Curr Allergy Asthma Rep* 2008;8:519–24.
- Verhoeven D, Xu Q, Pichichero ME. Differential impact of respiratory syncytial virus and parainfluenza virus on the frequency of acute otitis media is explained by lower adaptive and innate immune responses in otitis-prone children. *Clin Infect Dis* 2014;59:376–83.
- Mandel EM, Casselbrant ML. Recent developments in the treatment of otitis media with effusion. *Drugs* 2006;66:1565–76.
- Lack G, Caulfield H, Penagos M. The link between otitis media with effusion and allergy: a potential role for intranasal corticosteroids. *Pediatr Allergy Immunol* 2011;22:258–66.
- Bentdal YE, Nafstad P, Karevold G, Kvaerner KJ. Acute otitis media in schoolchildren: allergic diseases and skin prick test positivity. *Acta Otolaryngol* 2007;127:480–5.
- Arbes SJ Jr, Gergen PJ, Vaughn B, Zeldin DC. Asthma cases attributable to atopy: results from the Third National Health and Nutrition Examination Survey. *J Allergy Clin Immunol* 2007;120:1139–45.
- Bernstein JM. The role of IgE-mediated hypersensitivity in the development of otitis media with effusion: a review. *Otolaryngol Head Neck Surg* 1993;109(3 Pt 2):611–20.
- Bernstein JM, Lee J, Conboy K, Ellis E, Li P. Further observations on the role of IgE-mediated hypersensitivity in recurrent otitis media with effusion. *Otolaryngol Head Neck Surg* 1985;93:611–15.
- Kreiner-Moller E, Chawes BL, Caye-Thomasen P, Bonnelykke K, Bisgaard H. Allergic rhinitis is associated with otitis media with effusion: a birth cohort study. *Clin Exp Allergy* 2012;42:1615–20.
- MacIntyre EA, Chen CM, Herbarth O, Borte M, Schaaf B, Kramer U, et al. Early-life otitis media and incident atopic disease at school age in a birth cohort. *Pediatr Infect Dis J* 2010;29:e96–9.
- Nsouli TM, Nsouli SM, Linde RE, O'Mara F, Scanlon RT, Bellanti JA. Role of food allergy in serous otitis media. *Ann Allergy* 1994;73:215–19.
- Juntti H, Tikkanen S, Kokkonen J, Alho OP, Niinimäki A. Cow's milk allergy is associated with recurrent otitis media during childhood. *Acta Otolaryngol* 1999;119:867–73.
- Ishii T, Toriyama M, Suzuki JI. Histopathological study of otitis media with effusion. *Ann Otol Rhinol Laryngol Suppl* 1980;89(3 Pt 2):83–6.
- Friedman RA, Doyle WJ, Casselbrant ML, Bluestone C, Fireman P. Immunologic-mediated eustachian tube obstruction: a double-blind crossover study. *J Allergy Clin Immunol* 1983;71:442–7.
- Bluestone CD. Impact of evolution on the eustachian tube. *Laryngoscope* 2008;118:522–7.
- Bylander A. Upper respiratory tract infection and eustachian tube function in children. *Acta Otolaryngol* 1984;97:343–9.
- McBride TP, Derkay CS, Cunningham MJ, Doyle WJ. Evaluation of noninvasive eustachian tube function tests in normal adults. *Laryngoscope* 1988;98(6 Pt 1):655–8.
- Giebink GS. Otitis media: the chinchilla model. *Microb Drug Resist* 1999;5:57–72.
- Reuman PD, Swarts JD, Maddern BD, et al. The effects of influenza A H3N2, rhinovirus 39 and coxsackie A 21 infection on nasal and middle ear function in adult subjects. In: Proceedings of the 5th International Symposium on Recent Advances in Otitis Media. Toronto: BC Decker; 1993.
- Doyle WJ, Skoner DP, Hayden F, Buchman CA, Seroky JT, Fireman P. Nasal and otologic effects of experimental influenza A virus infection. *Ann Otol Rhinol Laryngol* 1994;103:59–69.
- Post JC, Aul JJ, White GJ, Wadowsky RM, Zavoral T, Tabari R, et al. PCR-based detection of bacterial DNA after antimicrobial treatment is indicative of persistent, viable bacteria in the chinchilla model of otitis media. *Am J Otolaryngol* 1996;17:106–11.
- Ryan AF, Ebmeyer J, Furukawa M, Pak K, Melhus A, Wasserman SI, et al. Mouse models

- of induced otitis media. *Brain Res* 2006;1091:3–8.
53. Chen A, Li HS, Hebda PA, Zeevi A, Swarts JD. Gene expression profiles of early pneumococcal otitis media in the rat. *Int J Pediatr Otorhinolaryngol* 2005;69:1383–93.
  54. Tong HH, Chen Y, Liu X, DeMaria TF. Differential expression of cytokine genes and iNOS induced by nonviable nontypeable *Haemophilus influenzae* or its LOS mutants during acute otitis media in the rat. *Int J Pediatr Otorhinolaryngol* 2008;72:1183–91.
  55. MacArthur CJ, Pillers DA, Pang J, Kempton JB, Trune DR. Altered expression of middle and inner ear cytokines in mouse otitis media. *Laryngoscope* 2011;121:365–71.
  56. Short KR, Reading PC, Brown LE, Pedersen J, Gilbertson B, Job ER, et al. Influenza-induced inflammation drives pneumococcal otitis media. *Infect Immun* 2013;81:645–52.
  57. Tong HH, Lambert G, Li YX, Thurman JM, Stahl GL, Douthitt K, et al. Deletion of the complement C5a receptor alleviates the severity of acute pneumococcal otitis media following influenza A virus infection in mice. *PLoS ONE* 2014;9:e95160.
  58. Zhang Y, Yu H, Xu M, Han F, Tian C, Kim S, et al. Pathological features in the *LmnaDhe/+* mutant mouse provide a novel model of human otitis media and laminopathies. *Am J Pathol* 2012;181:761–74.
  59. Li JD, Hermansson A, Ryan AF, Bakaletz LO, Brown SD, Cheeseman MT, et al. Panel 4: Recent advances in otitis media in molecular biology, biochemistry, genetics, and animal models. *Otolaryngol Head Neck Surg* 2013;148(Suppl. 4):E52–63.
  60. Hernandez M, Leichtle A, Pak K, Ebmeyer J, Euteneuer S, Obonyo M, et al. Myeloid differentiation primary response gene 88 is required for the resolution of otitis media. *J Infect Dis* 2008;198:1862–9.
  61. Lee HY, Takeshita T, Shimada J, Akopyan A, Woo JI, Pan H, et al. Induction of beta defensin 2 by NTHi requires TLR2 mediated MyD88 and IRAK-TRAF6-p38MAPK signaling pathway in human middle ear epithelial cells. *BMC Infect Dis* 2008;8:87.
  62. McCoy SL, Kurtz SE, MacArthur CJ, Trune DR, Hefeneider SH. Identification of a peptide derived from vaccinia virus A52R protein that inhibits cytokine secretion in response to TLR-dependent signaling and reduces in vivo bacterial-induced inflammation. *J Immunol* 2005;174:3006–14.
  63. Tong HH, Chen Y, James M, Van Deusen J, Welling DB, DeMaria TF. Expression of cytokine and chemokine genes by human middle ear epithelial cells induced by formalin-killed *Haemophilus influenzae* or its lipooligosaccharide *htrB* and *rfaD* mutants. *Infect Immun* 2001;69:3678–84.
  64. Tong HH, Long JB, Li D, DeMaria TF. Alteration of gene expression in human middle ear epithelial cells induced by influenza A virus and its implication for the pathogenesis of otitis media. *Microb Pathog* 2004;37:193–204.
  65. Tsuchiya K, Toyama K, Tsuprun V, Hamajima Y, Kim Y, Ondrey FG, et al. Pneumococcal peptidoglycan-polysaccharides induce the expression of interleukin-8 in airway epithelial cells by way of nuclear factor-kappaB, nuclear factor interleukin-6, or activation protein-1 dependent mechanisms. *Laryngoscope* 2007;117:86–91.
  66. Wasserman SI, Leichtle A, Hernandez M, Yamasaki K, Pak K, Ryan AF. CCL3 restores bacterial clearance in nontypeable *Haemophilus influenzae* (NTHi)-induced otitis media in TNF- $\alpha$  mice. *J Allergy Clin Immunol* 2009;123:S257.
  67. Ebmeyer J, Furukawa M, Pak K, Ebmeyer U, Sudhoff H, Broide D, et al. Role of mast cells in otitis media. *J Allergy Clin Immunol* 2005;116:1129–35.
  68. Kim JS, Yoon YJ, Lee EJ. Studies on distribution of alpha1-antitrypsin, lysozyme, lactoferrin, and mast cell enzymes in diseased middle ear mucosa. *Acta Otolaryngol* 2014;134:791–5.
  69. Depreux FF, Darrow K, Conner DA, Eavey RD, Liberman MC, Seidman CE, et al. Eya4-deficient mice are a model for heritable otitis media. *J Clin Invest* 2008;118:651–8.
  70. Lazaridis E, Saunders JC. Can you hear me now? A genetic model of otitis media with effusion. *J Clin Invest* 2008;118:471–4.
  71. Parkinson N, Hardisty-Hughes RE, Tateossian H, Tsai HT, Brooker D, Morse S, et al. Mutation at the Evil locus in Junbo mice causes susceptibility to otitis media. *PLoS Genet* 2006;2:e149.
  72. Haberal I, Corey JP. The role of leukotrienes in nasal allergy. *Otolaryngol Head Neck Surg* 2003;129:274–9.
  73. Hardisty RE, Erven A, Logan K, Morse S, Guinaud S, Sancho-Oliver S, et al. The deaf mouse mutant Jeff (Jf) is a single gene model of otitis media. *J Assoc Res Otolaryngol* 2003;4:130–8.
  74. Hardisty-Hughes RE, Tateossian H, Morse SA, Romero MR, Middleton A, Tymowska-Lalanne Z, et al. A mutation in the F-box gene, *Fbxo11*, causes otitis media in the Jeff mouse. *Hum Mol Genet* 2006;15:3273–9.
  75. Liao J, Kochilas L, Nowotschin S, Arnold JS, Aggarwal VS, Epstein JA, et al. Full spectrum of malformations in velo-cardio-facial syndrome/DiGeorge syndrome mouse models by altering *Tbx1* dosage. *Hum Mol Genet* 2004;13:1577–85.
  76. Ilija S, Goulielmos GN, Samonis G, Galanakis E. Polymorphisms in IL-6, IL-10, TNF-alpha, IFN-gamma and TGF-beta1 genes and susceptibility to acute otitis media in early infancy. *Pediatr Infect Dis J* 2014;33:518–21.
  77. Nokso-Koivisto J, Chonmaitree T, Jennings K, Matalon R, Block S, Patel JA. Polymorphisms of immunity genes and susceptibility to otitis media in children. *PLoS ONE* 2014;9:e93930.
  78. Fletcher MA, Fritzell B. Brief review of the clinical effectiveness of PREVENAR against otitis media. *Vaccine* 2007;25:2507–12.
  79. Heikkinen T, Chonmaitree T. Importance of respiratory viruses in acute otitis media. *Clin Microbiol Rev* 2003;16:230–41.
  80. Heikkinen T, Thint M, Chonmaitree T. Prevalence of various respiratory viruses in the middle ear during acute otitis media. *N Engl J Med* 1999;340:260–4.
  81. Shiao AS, Guo YC, Hsieh ST, Tsai TL. Bacteriology of medically refractory acute otitis media in children: a 9-year retrospective study. *Int J Pediatr Otorhinolaryngol* 2004;68:759–65.
  82. Jacobs MR. Prevention of otitis media: role of pneumococcal conjugate vaccines in reducing incidence and antibiotic resistance. *J Pediatr* 2002;141:287–93.
  83. Fireman B, Black SB, Shinefield HR, Lee J, Lewis E, Ray P. Impact of the pneumococcal conjugate vaccine on otitis media. *Pediatr Infect Dis J* 2003;22:10–16.
  84. Poehling KA, Szilagyi PG, Grijalva CG, Martin SW, LaFleur B, Mitchel E, et al. Reduction of frequent otitis media and pressure-equalizing tube insertions in children after introduction of pneumococcal conjugate vaccine. *Pediatrics* 2007;119:707–15.
  85. Pichichero ME, Casey JR, Hoberman A, Schwartz R. Pathogens causing recurrent and difficult-to-treat acute otitis media, 2003–2006. *Clin Pediatr (Phila)* 2008;47:901–6.
  86. Hawker JJ, Smith S, Smith GE, Morbey R, Johnson AP, Fleming DM, et al. Trends in antibiotic prescribing in primary care for clinical syndromes subject to national recommendations to reduce antibiotic resistance, UK 1995–2011: analysis of a large database of primary care consultations. *J Antimicrob Chemother* 2014;39:3423–30.
  87. Smirnova MG, Birchall JP, Pearson JP. Evidence of T-helper cell 2 cytokine regulation of chronic otitis media with effusion. *Acta Otolaryngol* 2005;125:1043–50.
  88. Wright ED, Hurst D, Miotto D, Giguere C, Hamid Q. Increased expression of major basic protein (MBP) and interleukin-5(IL-5) in middle ear biopsy specimens from atopic patients with persistent otitis media with effusion. *Otolaryngol Head Neck Surg* 2000;123:533–8.
  89. Tewfik TL, Mazer B. The links between allergy and otitis media with effusion. *Curr Opin Otolaryngol Head Neck Surg* 2006;14:187–90.
  90. Sobol SE, Taha R, Schloss MD, Mazer BD, Manoukian JJ, Tewfik TL, et al. T(H)2 cytokine expression in atopic children with otitis media with effusion. *J Allergy Clin Immunol* 2002;110:125–30.
  91. Nguyen LH, Manoukian JJ, Sobol SE, Tewfik TL, Mazer BD, Schloss MD, et al. Similar allergic inflammation in the middle ear and the upper airway: evidence linking otitis media with effusion to the united airways concept. *J Allergy Clin Immunol* 2004;114:1110–15.
  92. Nguyen LH, Manoukian JJ, Tewfik TL, Sobol SE, Joubert P, Mazer BD, et al. Evidence of allergic inflammation in the middle ear and nasopharynx in atopic children with otitis media with effusion. *J Otolaryngol* 2004;33:345–51.
  93. Smirnova MG, Birchall JP, Pearson JP. The immunoregulatory and allergy-associated cytokines in the aetiology of the otitis media with effusion. *Mediators Inflamm* 2004;13:75–88.
  94. American Academy of Family Physicians, American Academy of Otolaryngology-Head and Neck Surgery, American Academy of Pediatrics. Otitis media with effusion. *Pediatrics* 2004;113:1412–29.
  95. American Academy of Pediatrics. Diagnosis and management of acute otitis media. *Pediatrics* 2004;113:1451–65.
  96. Bluestone CD. Clinical course, complications and sequelae of acute otitis media. *Pediatr Infect Dis J* 2000;19(Suppl. 5):S37–46.
  97. Caye-Thomasen P, Hermansson A, Bakaletz L, Hellstrom S, Kanzaki S, Kerschner J, et al. Panel 3: Recent advances in anatomy, pathology, and cell biology in relation to otitis media pathogenesis. *Otolaryngol Head Neck Surg* 2013;148(Suppl. 4):E37–51.
  98. Kaleida PH, Stool SE. Assessment of otoscopists' accuracy regarding middle-ear effusion. Oscopic validation. *Am J Dis Child* 1992;146:433–5.

99. Palmu A, Puhakka H, Rahko T, Takala A, Kilpi T. Predicting the development and outcome of otitis media by tympanometry. *Int J Pediatr Otorhinolaryngol* 2002;62:135–42.
100. Browning GG, Rovers MM, Williamson I, Lous J, Burton MJ. Grommets (ventilation tubes) for hearing loss associated with otitis media with effusion in children. *Cochrane Database Syst Rev* 2010;10:CD001801.
101. Lous J, Ryborg CT, Thomsen JL. A systematic review of the effect of tympanostomy tubes in children with recurrent acute otitis media. *Int J Pediatr Otorhinolaryngol* 2011;75:1058–61.
102. Marchisio P, Chonmaitree T, Leibovitz E, Lieberthal A, Lous J, Mandel E, et al. Panel 7: Treatment and comparative effectiveness research. *Otolaryngol Head Neck Surg* 2013;148(Suppl. 4):E102–21.
103. Bonilla FA, Bernstein IL, Khan DA, Ballas ZK, Chinen J, Frank MM, et al. Practice parameter for the diagnosis and management of primary immunodeficiency. *Ann Allergy Asthma Immunol* 2005;94(5 Suppl. 1):S1–63.
104. Orange JS, Hossny EM, Weiler CR, Ballow M, Berger M, Bonilla FA, et al. Use of intravenous immunoglobulin in human disease: a review of evidence by members of the Primary Immunodeficiency Committee of the American Academy of Allergy, Asthma and Immunology. *J Allergy Clin Immunol* 2006;117(Suppl. 4):S525–53.
105. Paris K, Sorensen RU. Assessment and clinical interpretation of polysaccharide antibody responses. *Ann Allergy Asthma Immunol* 2007;99:462–4.
106. Wiertsema SP, Herpers BL, Veenhoven RH, Salimans MM, Ruven HJ, Sanders EA, et al. Functional polymorphisms in the mannan-binding lectin 2 gene: effect on MBL levels and otitis media. *J Allergy Clin Immunol* 2006;117:1344–50.
107. Ku CL, von Bernuth H, Picard C, Zhang SY, Chang HH, Yang K, et al. Selective predisposition to bacterial infections in IRAK-4-deficient children: IRAK-4-dependent TLRs are otherwise redundant in protective immunity. *J Exp Med* 2007;204:2407–22.
108. Picard C, von Bernuth H, Ku CL, Yang K, Puel A, Casanova JL. Inherited human IRAK-4 deficiency: an update. *Immunol Res* 2007;38:347–52.
109. Bousfiha AA, Jeddane L, Ailal F, Al Herz W, Conley ME, Cunningham-Rundles C, et al. A phenotypic approach for IUIS PID classification and diagnosis: guidelines for clinicians at the bedside. *J Clin Immunol* 2013;33:1078–87.
110. Fischer TF, Singer AJ, Gulla J, Garra G, Rosenfeld R. Reaction toward a new treatment paradigm for acute otitis media. *Pediatr Emerg Care* 2005;21:170–2.
111. Rovers MM, Zielhuis GA. Otitis media meta-analysis. *Pediatrics* 2004;114:508–9, author reply 509.
112. Hoberman A, Paradise JL, Rockette HE, Shaikh N, Wald ER, Kearney DH, et al. Treatment of acute otitis media in children under 2 years of age. *N Engl J Med* 2011;364:105–15.
113. Tahtinen PA, Laine MK, Huovinen P, Jalava J, Ruuskanen O, Ruohola A. A placebo-controlled trial of antimicrobial treatment for acute otitis media. *N Engl J Med* 2011;364:116–26.
114. Rovers MM, Glasziou P, Appelman CL, Burke P, McCormick DP, Damoiseaux RA, et al. Antibiotics for acute otitis media: a meta-analysis with individual patient data. *Lancet* 2006;368:1429–35.
115. Joint Task Force on Practice Parameters, American Academy of Allergy, Asthma and Immunology, American College of Allergy, Asthma and Immunology, Joint Council of Allergy, Asthma and Immunology. Drug allergy: an updated practice parameter. *Ann Allergy Asthma Immunol* 2010;105:259–73.
116. Coleman C, Moore M. Decongestants and antihistamines for acute otitis media in children. *Cochrane Database Syst Rev* 2008;3:CD001727.
117. Casselbrant ML, Villardo RJ, Mandel EM. Balance and otitis media with effusion. *Int J Audiol* 2008;47:584–9.
118. Koopman L, Hoes AW, Glasziou PP, Appelman CL, Burke P, McCormick DP, et al. Antibiotic therapy to prevent the development of asymptomatic middle ear effusion in children with acute otitis media: a meta-analysis of individual patient data. *Arch Otolaryngol Head Neck Surg* 2008;134:128–32.
119. Thomas CL, Simpson S, Butler CC, van der Voort JH. Oral or topical nasal steroids for hearing loss associated with otitis media with effusion in children. *Cochrane Database Syst Rev* 2006;3:CD001935.
120. Hurst DS. Efficacy of allergy immunotherapy as a treatment for patients with chronic otitis media with effusion. *Int J Pediatr Otorhinolaryngol* 2008;72:1215–23.
121. McMahan JT, Calenoff E, Croft DJ, Barenholtz L, Weber LD. Chronic otitis media with effusion and allergy: modified RAST analysis of 119 cases. *Otolaryngol Head Neck Surg* 1981;89(3 Pt 1):427–31.
122. Lous J. Which children would benefit most from tympanostomy tubes (grommets)? A personal evidence-based review. *Int J Pediatr Otorhinolaryngol* 2008;72:731–6.

## KEY POINTS

- Sinusitis is diagnostically challenging because symptoms (i.e. nasal discharge, congestion and cough), signs and radiographic findings are similar to those in common upper respiratory tract infections. Coronal sinus CT scans may be helpful in chronic, recurrent or complicated sinusitis.
- Respiratory infections (viruses, bacteria), bacterial biofilms and microbiome disruption have pathogenic roles. The most common causes of bacterial sinusitis are *Streptococcus pneumoniae* (20–30%), *Haemophilus influenzae* (20–30%) and *Moraxella catarrhalis* (10–20%); 30–35% are sterile.
- Antibiotic resistance is common: *Streptococcus pneumoniae* (15–50% penicillin resistant), *Haemophilus influenzae* (25–80%  $\beta$ -lactamase positive), and *Moraxella catarrhalis* (90–100%  $\beta$ -lactamase positive). Antral irrigation can provide sinus specimens for bacterial culture and targeted antimicrobial therapy in patients with chronic, refractory and complicated disease.
- Children with chronic sinusitis have mucosal pathology and inflammation that typically differs from adults. In adults, chronic sinusitis is characterized by mucosal thickening, goblet cell hyperplasia, subepithelial fibrosis and persistent Th2-type eosinophilic inflammation. In children, pan-immune inflammation (CD8<sup>+</sup> T lymphocytes, B lymphocytes, neutrophils) with reduced basement membrane thickness, fewer mucous glands, and less epithelial injury is common.
- Management of uncomplicated, acute sinusitis consists of antimicrobial treatment aiming for symptom relief and prevention of complications and recurrence. Severe intraorbital and intracranial complications are uncommon today.

This chapter on sinusitis in children will provide an overview of the pathogenesis and management of acute and chronic sinus disease. Although acute sinusitis has been substantially investigated, relatively little is known about chronic sinusitis in children.

### Sinus Development in Childhood

There are four pairs of paranasal sinuses in humans: maxillary, ethmoid, frontal, and sphenoid. The maxillary and ethmoid sinuses are present at birth and invaginate to become radiographically visible in the first 1 to 2 years of life (Figure 26-1). In comparison, frontal and sphenoid sinuses begin to develop

in the first few years of life and gradually become pneumatized and radiographically visible between 7 and 15 years of age. The maxillary, anterior ethmoid and frontal sinus ostia enter the nasal cavity through the middle meatus, under the middle turbinate (i.e. osteomeatal complex; see Figure 26-1). The sphenoid and posterior ethmoid ostia join the nasal cavity through the superior meatus, above the middle turbinate.

### Clinical Definitions of Sinusitis

Several descriptive modifiers for sinusitis are commonly used. In terms of sinusitis duration, (1) *acute* sinusitis refers to sinus symptoms of 10 to 30 days, with complete resolution of symptoms,<sup>1</sup> (2) *subacute* sinusitis refers to symptoms that last 30 to 90–120 days, and (3) *chronic* sinusitis is used for symptoms that last more than 90–120 days. *Recurrent* sinusitis occurs in patients who improve with sinus therapy but experience multiple episodes. *Refractory* sinusitis refers to patients who do not respond to conventional therapy for sinusitis.

The uses of the term *sinusitis* and *rhinosinusitis* have been debated; *sinusitis* implies that the disease is the manifestation of an infectious process of the sinuses.<sup>2</sup> In comparison, the term *rhinosinusitis* implies that the nasal and sinus mucosae are involved in similar and concurrent pathogenic (e.g. inflammatory) processes.<sup>1</sup> In this chapter the two terms will be used interchangeably.

### Epidemiology

Sinusitis is a common problem in childhood. In a study of 1- to 5-year-old children seen in pediatric practices, 9.3% met the clinical criteria of sinusitis (i.e.  $\geq 10$  days of symptoms).<sup>3</sup> In a large birth cohort study primarily intended to study the natural history of childhood asthma (Children's Respiratory Study, Tucson, Arizona), 13% of 8-year-old children reported physician-diagnosed sinusitis within the past year.<sup>4</sup> Of children with sinusitis, 50%, 18% and 11% had sinusitis diagnosed for the first time at ages 6 years, 3 years and 2 years, respectively. The main risk factors for sinusitis were current allergic rhinitis and grass pollen hypersensitivity.

The US National Center for Health Statistics reported that, from 1980 to 1992, sinusitis was the fifth leading diagnosis for which antibiotics was prescribed.<sup>5</sup> The annual outpatient visit rates for sinusitis increased about 3-fold over this period and the use of amoxicillin and cephalosporin antibiotics for sinusitis also increased significantly. Antibiotic resistance of bacterial pathogens from the sinuses of children with acute<sup>6</sup> and chronic sinusitis<sup>7</sup> is common. Severe alterations in quality of life can result from chronic recurrent sinusitis in children. Using a standardized child health questionnaire, children with chronic sinusitis and their parents reported more bodily pain and



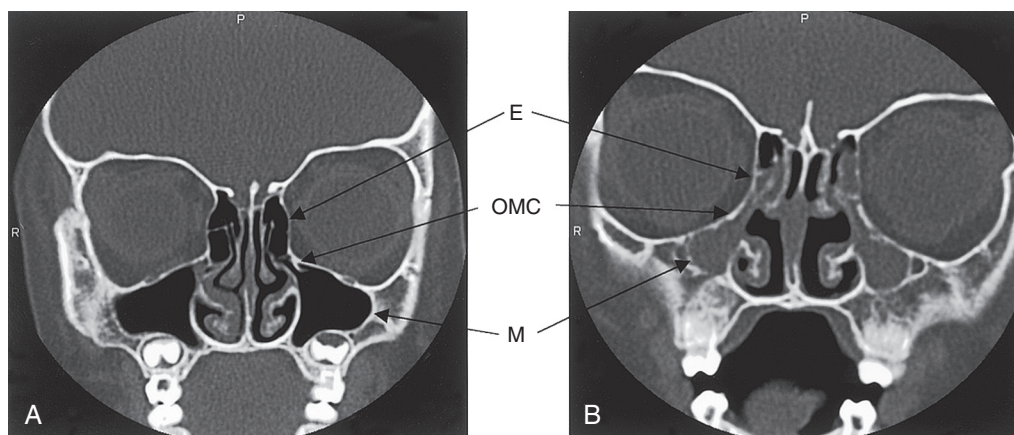

**Figure 26-1** Computed tomography scans of the paranasal sinuses. Coronal views of a 4-year-old child with (A) normal maxillary and ethmoid sinuses and patent osteomeatal complex and (B) opacified maxillary and ethmoid sinuses consistent with sinusitis. E – Ethmoid sinus; M – Maxillary sinus; OMC – Osteomeatal complex.

greater limitation in their physical activity than were typically reported by children with asthma or juvenile rheumatoid arthritis.<sup>8</sup> Complications of sinusitis, such as intracranial or intraorbital extension of bacterial infection from the sinuses, are medical emergencies that are life-threatening.

## Etiology

A combination of anatomic, mucosal, microbial and immune pathogenic processes is believed to underlie sinusitis in children. Children with congenital mucosal diseases (e.g. cystic fibrosis, ciliary dyskinesias) and lymphocyte immune deficiencies (congenital and acquired) typically have chronic recurrent sinus disease. Also, allergic airway diseases in children have both epidemiologic and pathogenic links to sinusitis.

## ANATOMIC PATHOGENESIS

Anatomic obstructions of the sinus ostia in the nasopharynx have long been suspected causes of sinusitis. The pathophysiology of osteomeatal obstruction leading to sinusitis is believed to be similar to that of otitis media.<sup>9</sup> For the middle ear space, animal model studies reveal that a lack of ventilation (i.e. oxygenation) of the middle ear results in negative pressure in the closed space, leading to mucosal vascular leakage, edema, inflammation and middle ear fluid accumulation.<sup>10,11</sup> Both anatomic obstructive lesions and mucosal disorders such as mucosal injury from viral upper respiratory tract infections (URTIs), inhalant allergies, cystic fibrosis and ciliary dyskinesias may begin this cascade of pathogenic events. Anatomic variations associated with sinusitis in children in uncontrolled studies include concha bullosa (10%), paradoxical turbinates (4–8%), lateralized uncinate process with hypoplastic maxillary sinus (7–17%), Haller cell (5–10%) and septal deviation (10%).<sup>12,13</sup> Recent studies have failed to establish a relationship between anatomic variations and the severity and extent of chronic sinusitis in children.<sup>14,15</sup> Adenoid hypertrophy has also been implicated as a possible predisposing factor to sinusitis in children by serving as a mechanical obstruction to nasal drainage; however, an etiologic role has not been established.<sup>16,17</sup> Therefore, it is not prudent to base surgical intervention on anatomic variations alone.

## MICROBIAL PATHOGENESIS

Both viral and bacterial infections have integral roles in the pathogenesis of sinusitis. Viral URTIs commonly cause sinus mucosal injury and swelling, resulting in osteomeatal obstruction, loss of ciliary activity and mucous hypersecretion. Indeed, radiologic sinus imaging studies of adults and children with common colds revealed that sinus mucosal abnormalities are the norm, and even air-fluid levels in the maxillary sinuses and opacification of the maxillary sinuses are common.<sup>18,19</sup> Specifically, coronal sinus computed tomography (CT) scans of adults with URTIs revealed that 87% had abnormalities of one or both maxillary sinuses, 77% had obstruction of the ethmoid infundibulum, 65% had abnormal ethmoid sinuses, 32% had abnormal frontal sinuses and 39% had abnormal sphenoid sinuses.<sup>19</sup>

Sneezing and nose blowing are thought to introduce nasal flora into the sinuses. Chronically infected adenoids, which may be colonized by bacterial biofilms, and intracellular bacteria (in particular, *Staphylococcus aureus*) in the nasopharynx have been proposed as nasopharyngeal reservoirs of pathogens that may be introduced into the sinuses.<sup>17,20</sup> Normal nasopharyngeal flora such as alpha streptococci and anaerobes may elaborate bacteriocins and other inhibitory compounds that interfere with colonization and infection by pathogenic bacteria.<sup>21</sup> Bacterial growth conditions are favorable in obstructed sinuses, reflected by bacterial concentrations of up to  $10^7$  bacterial colony-forming units (cfu)/mL in sinus aspirates. Additionally, bacterial biofilms have been demonstrated in sinus mucosal specimens obtained from 45% to 80% of children and adults with chronic sinusitis.<sup>22,23</sup> White blood cell counts in excess of 10,000 cells/mL in sinus aspirates are evidence of a robust inflammatory response to infection. The combination of infection, biofilm formation and inflammation can result in intense epithelial damage and transmucosal injury.<sup>24,25</sup>

### Microbiology of Acute and Subacute Sinusitis

The gold standard for microbiologic diagnosis of bacterial sinusitis has been the recovery of  $\geq 10^4$  cfu/mL of pathogenic bacteria from a sinus aspirate.<sup>1,26</sup> Studies employing sinus aspirates indicate that the pathogens responsible for acute and subacute sinusitis are similar to each other and mirror those responsible for acute otitis media<sup>26–31</sup> (Table 26-1). *Streptococcus*

**TABLE 26-1** Microbiology of Acute, Subacute and Chronic Sinusitis

Microorganism	FREQUENCY		
	Common	Occasional	Uncommon
<i>Streptococcus pneumoniae</i>	A, C		
<i>Haemophilus influenzae</i> , nontypable	A, C		
<i>Moraxella catarrhalis</i>	A, C		
<i>Streptococcus pyogenes</i>		A, C	
Other streptococcal species (including <i>Streptococcus milleri</i> )		A, C	
<i>Staphylococcus aureus</i> (including methicillin-resistant <i>S. aureus</i> )		C	A
Diphtheroids		C	
Coagulase-negative staphylococci		C	
Other Gram-negatives, <i>Moraxella</i> , <i>Neisseria</i>		C	A
Anaerobes		C	A
Respiratory viruses	A, C		
Fungi ( <i>Aspergillus</i> , <i>Alternaria</i> , other dematiaceous fungi, zygomycetes)*		C	A
<i>Acanthamoeba</i> †			A

A – Acute and subacute sinusitis; C – Chronic sinusitis.

\*Primarily in immunocompromised hosts or associated with allergic fungal sinusitis.

†Primarily in immunocompromised hosts.

*pneumoniae* is recovered in approximately 20% to 30% of cases, nontypable *Haemophilus influenzae* in approximately 20% to 30%, and *Moraxella catarrhalis* in approximately 10% to 20%. Similar to observations for acute otitis media, a modest reduction in the proportion due to *S. pneumoniae* and a corresponding increase in the proportion due to *H. influenzae* is suggested in populations with routine pneumococcal conjugate vaccination of young children.<sup>21</sup> A significant proportion of *S. pneumoniae* isolates have intermediate or high-level resistance to penicillin due to alterations in penicillin-binding proteins (up to 15–50%). *H. influenzae* and *M. catarrhalis* isolates are frequently  $\beta$ -lactamase positive (25–80% and 90–100%, respectively), and a minority of *H. influenzae* are ampicillin resistant due to altered penicillin-binding proteins and/or an efflux pump.<sup>21,32</sup> Actual resistance rates vary with time period, geographic region and the prevalence of risk factors for resistance (e.g. age <2 years, daycare attendance, recent antibiotic exposure). *Streptococcus pyogenes* and other streptococcal species are generally recovered in only a small number of cases, although several series have highlighted a frequent association between recovery of *Streptococcus anginosus* group with acute sinusitis leading to intraorbital and/or intracranial complications in children and adults.<sup>33,34</sup> *Staphylococcus aureus* and anaerobes are uncommon causes of acute and subacute pediatric sinusitis;

however, they are more frequently identified in severe, complicated disease, or, in the case of anaerobes, associated with dental disease.<sup>35</sup> Less commonly recovered bacteria include Gram-negative organisms such as *Eikenella corrodens* and other *Moraxella* and *Neisseria* species. Fungi are uncommonly recovered in acute sinusitis except in immunocompromised patients.<sup>27</sup> The protozoan *Acanthamoeba* has also been identified as a rare cause of sinusitis in severely immunosuppressed hosts.<sup>36,37</sup> Sinus aspirates are sterile in approximately 30% to 35% of children with clinically and/or radiographically diagnosed sinusitis.<sup>1,26,30,38</sup> Acute sinusitis in children has been associated with rhinovirus URTIs.<sup>39</sup> Chronic rhinosinusitis (CRS) has also been associated with nasal respiratory viruses. Comparing nasal lavage from CRS participants with non-CRS controls: nasal respiratory virus detection (50% vs 26%), especially rhinovirus (26% vs 10%), parainfluenza virus (23% vs 8%), influenza virus (13% vs 4%), RSV (11% vs 2%), and multiple respiratory viruses (24% vs 4%, respectively).<sup>40</sup> Respiratory viruses have been recovered from ~10% of sinus aspirates, although sinus aspirates and biopsy investigations with more sensitive modern viral detection methods may provide additional insights.<sup>26</sup> Whether or not respiratory viruses have a direct pathogenic role in sinusitis is poorly understood, but it is clear that viral rhinosinusitis and bacterial sinusitis may have overlapping clinical and radiographic features that make clinical diagnosis of the latter entity challenging.<sup>32</sup>

### Microbiology of Chronic Sinusitis

Infection is a key component in pediatric chronic sinusitis, although concomitant factors may be an important contributor to the chronic inflammatory process.<sup>41</sup> In numerous studies, 65% to 100% of children with chronic sinusitis have positive cultures of sinus aspirates.<sup>7,42–46</sup> Rates of recovery of specific organisms vary among studies; this variability is likely to be explained by differences in patient populations, sinuses evaluated, specimen collection methods and microbiologic culture techniques. Despite these differences, certain general observations can be made. *S. pneumoniae*, *H. influenzae* and *M. catarrhalis* are frequently isolated from children with chronic sinusitis, mirroring acute and subacute sinusitis<sup>7,43,47</sup> (see Table 26-1). With increasing chronicity, other organisms may also be recovered, including *S. aureus*, *S. pyogenes*, alpha streptococci (including *Streptococcus anginosus* group), group D streptococci, diphtheroids, coagulase-negative staphylococci, *Neisseria* species, Gram-negative aerobic rods (including *Pseudomonas aeruginosa*), and anaerobes; infection is frequently polymicrobial.<sup>42,44–46</sup> *S. aureus* and anaerobes tend to be disproportionately associated with protracted, severe or complicated disease.<sup>48–51</sup> In concert with the overall increase in community-acquired methicillin-resistant *S. aureus* (MRSA) infections, an increased frequency of MRSA-associated sinus infections has been observed.<sup>52</sup> Recovery of anaerobes (e.g. *Peptococcus*, *Peptostreptococcus*, *Propionibacterium acnes*, *Prevotella*, *Veillonella*, *Fusobacterium*, *Bacteroides* and *Actinomyces*) has varied widely from less than 5% to more than 90%, depending on the populations and sinuses evaluated and microbiologic methods employed.<sup>42–46,53,54</sup> Many anaerobic isolates are  $\beta$ -lactamase producing.<sup>35,55</sup>

In a study using modern profiling techniques to determine the sinus microbiome in chronic rhinosinusitis, an abundance of a single fastidious species, *Corynebacterium tuberculo-stearicum*, and depletion of *Lactobacillus sakei* was identified



compared with healthy controls.<sup>56</sup> In a mouse model, *C. tuberculoostearicum* was demonstrated to be a sinus pathogen following pretreatment with amoxicillin-clavulanic acid, and protection against this organism was conferred by pretreatment with *L. sakei*.

Fungi, including *Aspergillus*, *Alternaria* and other dematiaceous species (e.g. *Bipolaris* and *Curvularia*), and zygomycetes are occasionally isolated, although invasive disease is uncommon except in immunocompromised children.<sup>45</sup> Respiratory viruses are occasionally identified in sinus mucosal or lavage specimens.<sup>57,58</sup> Interestingly, bilateral cultures of the sinuses are often discordant.<sup>7,46</sup>

Antibiotic resistance has emerged as an important factor in the microbiology of chronic sinusitis. For example, in a 4-year retrospective review of maxillary sinus aspirates from children with sinusitis for more than 8 weeks, rates of nonsusceptibility of *S. pneumoniae* (recovered in 19% of cultures) were 64% for penicillin, 40% for cefotaxime and 18% for clindamycin.<sup>7</sup> Of *H. influenzae* isolates (recovered in 24%), 44% were nonsusceptible to ampicillin, and all *M. catarrhalis* isolates (recovered in 17%) were  $\beta$ -lactamase positive.

## IMMUNE PATHOGENESIS

There are few studies in the literature on the immunopathology of sinusitis in children. Most of our knowledge is derived from studies conducted on adults with chronic hyperplastic sinusitis and nasal polyposis (CHS/NP). In adults, chronic sinusitis is

characterized by mucosal thickening, goblet cell hyperplasia, subepithelial fibrosis and persistent inflammation<sup>59</sup> (Figure 26-2). These fibrotic changes are thought to be driven by activated eosinophils and their products, including the profibrotic transforming growth factor- $\beta$ ,<sup>60</sup> GM-CSF<sup>61,62</sup> and interleukin (IL)-11.<sup>63</sup> Tissue fibroblasts are stimulated to increase the synthesis and deposition of collagen and matrix products, resulting in thickening of the sub-basement membrane layer.

Current views associate sensitivity to aeroallergens as a primary pathologic mechanism in the development of chronic sinusitis in both adults<sup>64,65</sup> and children.<sup>66</sup> Many studies have shown that the composition of the inflammatory substrate in chronic sinusitis is similar to that seen in allergic rhinitis and the late-phase response to antigen challenge.<sup>64,67</sup>

### Th2-Mediated Eosinophilic Inflammation

Although many immune cell types are involved in the pathogenesis of chronic sinusitis, a specific subclass of T lymphocytes (i.e. T helper cell type 2 [Th2] lymphocytes) and eosinophils appear to have a central role. The orchestration of cellular recruitment and activation of the inflammatory infiltrate in CHS/NP has been largely attributed to the Th2 cells and their cytokines (i.e. IL-3, IL-4, IL-5, IL-9, IL-13, GM-CSF). Among immune cell types, eosinophils are the most characteristic and are found in 80% to 90% of nasal polyps.<sup>68</sup> A histopathologic study has investigated the inflammatory cells in pediatric chronic sinusitis and reported similar findings: the numbers of eosinophils, and to a much lesser extent mast cells and T

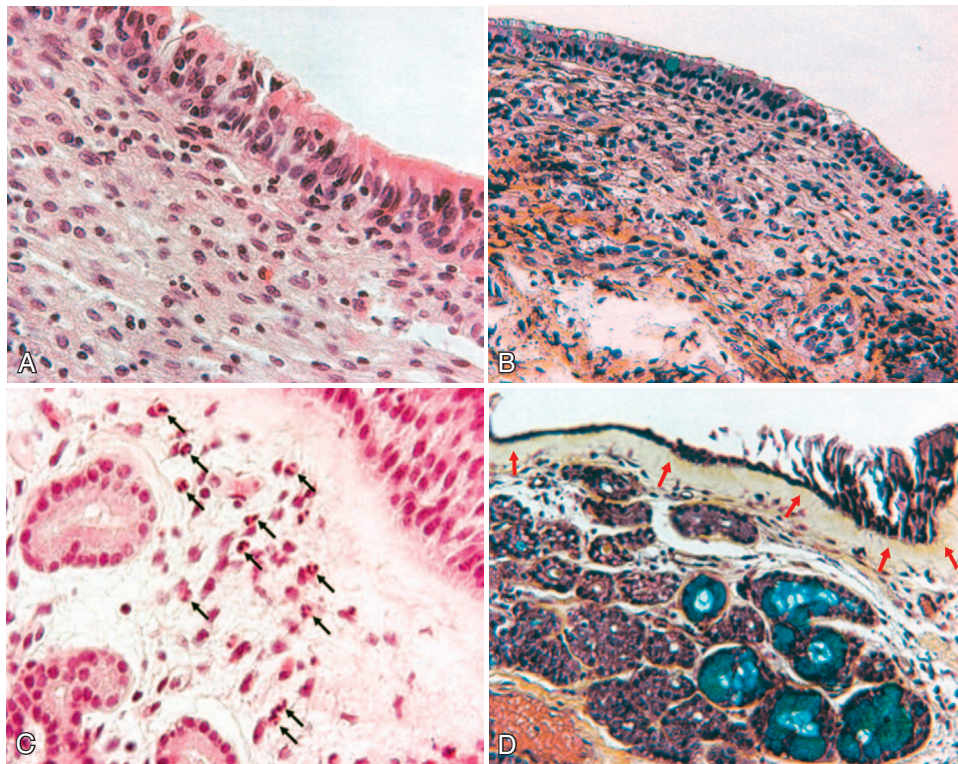

**Figure 26-2** Chronic sinusitis: sinus mucosal biopsies from children (A and B) and adults (C and D). (A) and (C): Hematoxylin and eosin stained (original magnification  $\times 400$ ). Arrows on the adult photo (C) point to some of the eosinophils in this image. There is a relative abundance of lymphocytes and scarcity of eosinophils in the pediatric specimen (A) compared with adult tissue (C). (B) and (D): Pentachrome stained (original magnification  $\times 200$ ). Arrows on the adult photo (D) point to thickened basement membrane. Basement membrane thickening, mucous gland hyperplasia and hypertrophy, and loss of columnar epithelium in the adult sample (D) are not seen in the pediatric sample (B).

lymphocytes, are significantly increased in children with chronic sinusitis compared to control subjects<sup>69</sup> (see Figure 26-2). The degree of tissue eosinophilia was not affected by the allergic status of patients. This is in agreement with published studies on chronic sinusitis in the adult population where the level of eosinophilic infiltration was found to be similar between allergic and nonallergic patients with either chronic sinusitis without nasal polyps<sup>70,71</sup> or CHS/NP.<sup>72,73</sup> Levels of neutrophils are also increased in the sinus lavage fluid of adults with chronic sinusitis, particularly in nonallergic patients.<sup>74</sup>

*Allergic fungal sinusitis (AFS)*, an uncommon condition due to an intense and chronic allergic reaction to fungi growing in allergic mucin within the sinus cavities, is believed to be pathogenetically similar to allergic bronchopulmonary mycoses.<sup>75,76</sup> *Aspergillus* and dematiaceous fungi (e.g. *Alternaria*, *Curvularia*, *Bipolaris*) have been cultured from affected sinuses. Nasal polyposis, facial deformity, bony erosion of the sinuses, proptosis and fungal hyphae in allergic mucin filling the sinuses are common in children with AFS.<sup>77-79</sup> Because of its destructive nature, AFS is managed aggressively, with topical and oral corticosteroids after surgical debridement.<sup>75,79</sup> Antifungal therapy (e.g. itraconazole) has been associated with clinical improvement, oral steroid reduction and resolution of disease in some series.<sup>80,81</sup>

*Chronic rhinosinusitis in young children* differs from the common pathology in older children and adults. Sinus mucosal biopsies from younger children (median age 3.9 years; range 1.4–8.2) with chronic rhinosinusitis (i.e. despite at least two courses of antibiotics, one with a second-line agent), when compared with adult sinusitis controls, had significantly fewer eosinophils, less basement membrane thickness, fewer submucosal mucous glands and less epithelial injury.<sup>82</sup> These young children had more CD8<sup>+</sup> (cytotoxic T lymphocytes), CD20<sup>+</sup> (B lymphocytes), myeloperoxidase-positive (neutrophils) and CD68<sup>+</sup> (monocytes, macrophages) cells in sinus epithelium and/or submucosal tissues.<sup>83</sup> Those whose sinus cultures grew a bacterial pathogen (55%) had significantly more submucosal neutrophils. This pan-immune histopathology might indicate inadequate and/or dysregulated immune responses to bacterial biofilms, pathogenic microbiomes and/or common respiratory viruses.

### Asthma and Allergy Risk Factors

Along with histologic evidence that the immune pathologic processes of chronic sinusitis and asthma can be similar, epidemiologic, radiographic and clinical studies also link sinusitis with asthma. In a large European survey study, a strong association of asthma with chronic rhinosinusitis (adjusted odds ratio 3.47) was observed at all ages, and was stronger in those also reporting allergic rhinitis (aOR 11.85).<sup>84</sup> Using plain radiography of the sinuses, the prevalence of radiographic sinus abnormalities was significantly higher in asthmatic children (31%) than nonasthmatic controls (0%).<sup>85</sup> In asthmatic children who were hospitalized for an acute exacerbation, significant radiographic abnormalities of the sinuses were revealed in 87%.<sup>86</sup> A study of patients undergoing surgery for chronic sinusitis found that sinus CT evidence of extensive disease was associated with asthma, allergen sensitization and peripheral blood eosinophilia.<sup>87</sup> Of those with eosinophilia, 87% had extensive sinus disease.

Allergic rhinitis and inhalant allergen sensitization have also been associated with sinusitis in children. In a large birth cohort study, both allergic rhinitis and grass pollen sensitization

were significant and independent risk factors for sinusitis in childhood (i.e. age 8 years).<sup>4</sup> Experimentally, in allergic rhinitis subjects, nasal provocation with allergen induced sinus radiographic changes (i.e. mucosal thickening, sinus opacification) and symptoms of headache and pressure in the maxillary sinuses.<sup>88</sup>

## GENETIC RISK FACTORS

Association studies between chronic sinusitis and a few candidate gene markers have been reported. Chronic rhinosinusitis, and sometimes nasal polyposis, are hallmark features of cystic fibrosis (CF) and primary ciliary dyskinesia, two autosomal recessive inherited disorders. A small proportion of chronic sinusitis patients without CF are carriers of mutations in the cystic fibrosis transmembrane regulator (*CFTR*) gene, especially in association with the M470V polymorphism;<sup>89,90</sup> however, siblings of CF patients, who are all *CFTR* mutation carriers, do not have an increased prevalence of rhinosinusitis.<sup>91</sup> Modest linkages of single-nucleotide polymorphisms (SNPs) in other CRS candidate genes include TNF- $\alpha$  (CHS/NP),<sup>92</sup> LTC4 synthase,<sup>93</sup> TGF- $\beta$ 1,<sup>94</sup> TNF- $\beta$ 2 (chronic sinusitis),<sup>95</sup> and the major histocompatibility B54 haplotype.<sup>96</sup> A replication study of 53 CRS-associated SNPs replicated significance for SNPs in seven good gene candidates, especially prolyl-tRNA synthetase 2 (odds ratio 0.77), transforming growth factor B1 (OR 0.81) and nitric oxide synthase 1 (OR 0.84).<sup>97</sup>

## OTHER RISK FACTORS

Medical conditions that render children susceptible to acute and chronic sinus disease include immune deficiencies (especially patients with T and B lymphocyte defects, AIDS and those receiving immunosuppressive medications) and primary ciliary dyskinesias. The association of gastroesophageal reflux disease (GERD) with chronic sinusitis has also received attention. GERD, diagnosed by pH-monitored nasopharyngeal acid reflux<sup>98</sup> or esophageal biopsy,<sup>99</sup> was associated with rhinosinusitis in children. Phipps and colleagues<sup>100</sup> also reported significantly increased nasopharyngeal reflux in children with chronic sinusitis when compared with a historical control group. Anti-reflux treatment of their GERD-positive cohort resulted in a 79% improvement in chronic sinusitis symptoms.

## Sinusitis Management

### OVERVIEW

Medical histories and physical examinations can help to distinguish sinusitis in children from URTIs and other masqueraders and to identify complications from sinusitis and underlying risk factors for chronic recurrent disease. Radiographic imaging studies are particularly helpful in evaluating children with chronic, recurrent or complicated sinusitis. Sinus washings for bacterial culture and targeted antimicrobial therapy, while ideal, are surgical procedures (e.g. antral irrigation) that require general anesthesia in children. Therefore, their use is generally reserved for (1) children with chronic sinusitis that does not adequately improve with multiple courses of antibiotics, (2) children with sinusitis with complications, and (3) sinusitis in immunocompromised hosts. Differential diagnostic considerations are provided in Box 26-1.



### BOX 26-1 DIFFERENTIAL DIAGNOSIS AND RISK FACTORS FOR ACUTE AND CHRONIC SINUSITIS IN CHILDREN

#### ACUTE SINUSITIS

- Prolonged viral upper respiratory tract infection
- Foreign body in the nose
- Acute exacerbation of inhalant allergies
- Acute adenoiditis or adenotonsillitis

#### CHRONIC SINUSITIS

- Rhinitis, allergic and nonallergic
- Anatomic causes of nasopharyngeal obstruction
  - Turbinate hypertrophy
  - Adenoid hypertrophy
  - Nasal polyps
  - Severe septal deviation
  - Choanal atresia
  - Asthma
- Neoplasms of the nose and nasopharynx
  - Juvenile angiofibroma
  - Rhabdomyosarcoma
  - Lymphoma
  - Dermoid cyst
- Cystic fibrosis
- Lymphocyte immune deficiencies
  - B lymphocytes – antibody deficiencies
  - T lymphocyte deficiencies – congenital and acquired
- Primary ciliary dyskinesias
- Wegener's granulomatosis
- Churg-Strauss vasculitis
- Dental caries/abscess
- Gastroesophageal reflux disease with nasopharyngeal reflux

Consensus-based guidelines on the management of sinusitis in children have been published, from the American Academy of Pediatrics (AAP),<sup>1</sup> the Infectious Diseases Society of America (IDSA),<sup>101</sup> the American Academy of Allergy, Asthma and Immunology,<sup>102</sup> and the American Academy of Otolaryngology–Head and Neck Surgery.<sup>103</sup> These consensus guidelines, along with randomized controlled trials, systematic reviews and meta-analyses of specific management topics, have been considered in the following discussion.

## HISTORY AND PHYSICAL EXAMINATION

### Acute Sinusitis

Persisting, non-improving symptoms, such as nasal discharge (76%) and cough (80%), lasting longer than 10 to 14 days are the most common presentation of acute sinusitis in children.<sup>1,26,101</sup> Nasal discharge can be of any quality, and cough can be daytime, nighttime or both. Fever may accompany the illness. Less common presentations include severe symptoms such as high fever, purulent nasal discharge or facial pain for 3 to 4 days or longer at the start of illness, or worsening symptoms after 5 to 6 days of a viral URTI that had been improving.<sup>1,101</sup>

Although headaches and sinus tenderness are generally believed to be the hallmarks of sinusitis, a study of 200 sinusitis patients did not find a significant correlation of facial pain or headache with abnormal findings on sinus CT.<sup>104</sup> Additionally, the reported regions of facial pain did not correlate with radiographically identified sinus abnormalities. The nasal cavity is usually filled with discharge and the nasal mucosa and

turbinates are generally edematous. Following decongestion of the nasal cavity, purulent drainage coming from the middle meatus can sometimes be observed in older children. Tenderness over the frontal sinus in older children may indicate frontal sinus disease, but tenderness, in general, is uncommon in children with acute disease. Transillumination, considered by some to be a useful tool in adults, is unreliable in children.

### Chronic Sinusitis

The most common symptoms associated with chronic sinusitis in children are nasal discharge (59%), facial pain/discomfort (33%), nasal congestion (30%), cough (19%) and wheezing (19%).<sup>103</sup> Nasal discharge can be of any quality, but purulent discharge is the most common. Daytime mouth-breathing and snoring are common complaints. Examination of the nasal cavity may or may not reveal nasal discharge. The nasal turbinates are generally enlarged and can be edematous or erythematous. Although facial pain or discomfort may be a common complaint, tenderness over the sinuses is an uncommon finding in children.

## RADIOGRAPHIC IMAGING

A consensus report provided by the American College of Radiology<sup>105</sup> provided appropriateness criteria of different radiographic imaging modalities in assessing pediatric sinus disease. Currently, coronal CT is the recommended examination for imaging persistent or chronic sinusitis in patients of any age. Plain sinus radiographs (Waters and Caldwell projections), although widely available, can both underdiagnose and overdiagnose sinus soft tissue changes. Magnetic resonance imaging provides superior soft tissue delineation; however, it is expensive, has limited availability and does not provide bony details of the osteomeatal complex. Conventional tomography, nuclear medicine studies and ultrasound have significant limitations for imaging the sinuses.

It is tempting to consider sinus mucosal abnormalities and associated anatomic variations seen in imaging studies in symptomatic patients as clear indications for sinusitis therapy (e.g. antimicrobial therapy and sinus surgery). However, the clinical importance of such findings is challenged by studies that have revealed a high prevalence of such soft tissue findings in people without sinusitis symptoms or with URTIs.<sup>18,19</sup> In these studies, URTI symptoms and associated radiographic sinus abnormalities have improved without specific sinusitis therapy (i.e. no antibiotics or surgery for sinusitis).

The American College of Radiology consensus report has the following recommendations: (1) the diagnoses of acute and chronic sinusitis should be made clinically and not on the basis of imaging findings alone; (2) no imaging studies are indicated for acute sinusitis except for cases where complications are suspected or cases that are not responding to therapy; and (3) if imaging information in patients with chronic sinusitis is desired, coronal sinus CT is recommended. The use of plain radiographs of the sinuses (i.e. Waters and Caldwell views) is generally discouraged in this report, except in children younger than 4 years of age. The use of Waters view radiographs in children is supported by a study in which the sensitivity and specificity of a Waters view radiograph to diagnose chronic sinusitis in children were 76% and 81%, respectively.<sup>106</sup> In the same study, limited coronal CT scans were better than sinus x-rays and nearly as good as full sinus CT evaluations.

## SINUSITIS COMPLICATIONS

Complications of sinusitis (Table 26-2) are generally believed to be acute events that result from a combination of outflow obstruction and pathogenic bacteria in the sinuses. Intracranial extension of infection is by direct erosion, thrombophlebitis or extension through preformed pathways (e.g. fracture lines). The incidence of intracranial complications in children hospitalized for sinusitis was 3%.<sup>107</sup>

Orbital complications from sinusitis are primarily the result of acute ethmoid disease but could occasionally be extensions of frontal disease.<sup>108</sup> A classic description of the progression of sinusitis to orbital complications is as follows: inflammatory edema, orbital cellulitis, subperiosteal abscess, orbital abscess and cavernous sinus thrombosis.<sup>109</sup> The most common presentations of orbital complications include eyelid edema, orbital pain, diplopia, proptosis, and chemosis, as well as fever, nasal discharge and headache.<sup>110</sup> In a cohort of hospitalized children with orbital complications from sinusitis, 72% had a history of a URTI and 24% had received oral antibiotic therapy prior to their presentation with orbital complications.<sup>110</sup> It can be difficult to differentiate between preseptal cellulitis and orbital cellulitis on clinical parameters alone (i.e. based on lid edema and pain), without an imaging study. In orbital cellulitis, proptosis progresses and chemosis, ophthalmoplegia and reduced visual acuity may ensue. Orbital abscesses and cavernous sinus thrombosis caused by bacterial sinusitis are uncommon today.

Intracranial complications from sinusitis primarily result from frontal or sphenoid sinus disease.<sup>107</sup> There are many similarities between the pathogenesis of intracranial extension of sinusitis and that of otitis media. Intracranial complications in the preantibiotic era were devastating, with mortality rates of up to 75%. Current mortality rates for these complications are between 10% and 20%. Cavernous sinus thrombosis is a unique intracranial complication of ethmoid and sphenoid sinusitis by direct extension or venous communication. This complication is characterized by a toxic-appearing patient with infectious/inflammatory involvement of cranial nerves III, IV and VI, resulting in ophthalmoplegia. Progressive disease within the cavernous sinus can lead to carotid artery thrombosis and

mycotic aneurysm formation, resulting in neurologic sequelae and death.

Complications of maxillary sinusitis are rare. Mucoceles in the maxillary sinus are occasionally encountered in children with cystic fibrosis. Osteomyelitis of the maxillary sinus, more prevalent in the preantibiotic era and in adults with dental disease, is rare today.

## Sinusitis Treatment

### ANTIMICROBIAL THERAPY

#### Acute and Subacute Sinusitis

The goals of therapy for acute and subacute sinusitis are to hasten clinical improvement, prevent intracranial and orbital complications, and prevent mucosal damage that may predispose to chronic sinus disease<sup>27,28</sup> (Box 26-2). The actual benefit of antibiotics in achieving these goals has not been conclusively proven. A pivotal randomized trial showed that antibiotic therapy (amoxicillin or amoxicillin-clavulanic acid) for acute sinusitis, defined by clinical and plain radiograph criteria, was associated with symptom resolution in 66% of children at 10 days, significantly greater than the 43% rate of resolution among placebo-treated subjects.<sup>111</sup> Two subsequent randomized trials call into question the benefit of antibiotic treatment. One compared amoxicillin, amoxicillin-clavulanate and placebo in children with clinically diagnosed acute sinusitis and found no differences in symptom improvement at 14 days (79–81%), or relapse or recurrence rates.<sup>112</sup> The other compared cefuroxime and placebo in children with nonimproving respiratory symptoms and abnormal maxillary sinus ultrasonography; no difference in rates of improvement or cure at 14 days (84–91%) was observed.<sup>113</sup> A fourth trial randomized children with acute sinusitis to receive amoxicillin-clavulanate or placebo. Antibiotic treatment was associated with a superior cure rate (50% vs 14%) and less treatment failure (14% vs 68%).<sup>114</sup> In the IDSA guidelines, a meta-analysis of antibiotic randomized, controlled

TABLE  
26-2

Sinusitis Complications (by Sinus Involvement)

Complication	Maxillary Sinus	Ethmoid Sinus	Frontal Sinus	Sphenoid Sinus
Osteomyelitis	+		++	
Mucocele	++	++	++	+
Preseptal cellulitis		+++		
Orbital cellulitis		+++	+	
Subperiosteal abscess		+++		
Orbital abscess		+		
Meningitis			++	
Epidural abscess			++	
Subdural abscess			+	
Brain abscess			+	

+++ – Frequent, ++ – less frequent, + – least frequent.

### BOX 26-2 KEY CONCEPTS

#### USE OF ANTIMICROBIALS IN SINUSITIS

- For acute and subacute sinusitis, target therapy toward the same pathogens responsible for acute otitis media: *Streptococcus pneumoniae*, *Haemophilus influenzae* and *Moraxella catarrhalis*.
- Broad-spectrum antibiotics targeting  $\beta$ -lactamase-producing organisms and resistant *S. pneumoniae* should be used when there is:
  - Poor response to first-line antibiotics
  - Moderate-severe, chronic or recurrent disease
  - Complicated or potentially complicated disease (including frontal or sphenoidal involvement)
  - High risk for first-line antibiotic-resistant organisms: antibiotic therapy within the preceding 30–90 days, daycare attendance, age <2 years, high endemic rates of resistant pathogens
- Treat acute sinusitis for at least 10–14 days and until asymptomatic plus an additional 7 days.
- Consider sinus aspiration for microbiologic identification and targeted antimicrobial therapy if disease is:
  - Severe
  - Associated with orbital or intracranial complications
  - Unresponsive to multiple antibiotic courses
  - In immunocompromised patients

trials of children with acute sinusitis concluded modest benefit, with approximately five children requiring therapy for one additional child with cure or improvement.<sup>101</sup> Meta-analyses of studies in adults with acute sinusitis suggest similar modest benefit of antibiotic therapy, in part because approximately two thirds of adults with acute sinusitis improve without antibiotic treatment.<sup>101,115–119</sup>

Despite lack of definitive proof of efficacy, antibiotic treatment is recommended for most children with acute and subacute sinusitis because bacterial pathogens are recoverable from the majority of affected sinuses,<sup>1,17</sup> antibiotic treatment may be associated with greater rates of clinical improvement, and preventing sinusitis complications is a major concern.<sup>1,101</sup> Several days of watchful waiting for spontaneous clinical improvement prior to initiating antibiotic treatment is an alternative for persistent, non-severe symptoms.<sup>1</sup> There is a paucity of trial data in children to indicate which antibiotics may be superior, although studies performed in adults suggest comparable clinical efficacy of commonly used agents.<sup>21</sup> Antibiotic selection is frequently directed by typical susceptibility profiles of frequently isolated bacteria and pharmacokinetic properties of candidate antibiotics<sup>27,28</sup> (Table 26-3). Because their microbiology is similar, the approach to antibiotic selection for acute and subacute sinusitis is similar. Amoxicillin is commonly recommended for previously untreated, mild and uncomplicated acute sinusitis based on its excellent tolerability, low cost, narrow spectrum and track record for both sinusitis and otitis media; this option is preferred in the AAP guidelines for uncomplicated, mild-moderate disease in children lacking risk factors for antibiotic resistance.<sup>1,120,121</sup> This parallels recommendations for adults, in whom meta-analyses of randomized trials support the efficacy of amoxicillin (and penicillin) for acute sinusitis.<sup>115,122,123</sup> However, a 5% to 20% failure rate can be expected with amoxicillin because of resistant *S. pneumoniae*, *H. influenzae* and *M. catarrhalis*.<sup>1,31</sup> High-dose amoxicillin (80–90 mg/kg/day) can be used to improve eradication of potentially non-susceptible *S. pneumoniae* in children with risk factors for antibiotic resistance (e.g. antibiotic therapy within the preceding 30 to 90 days, daycare attendance, age <2 years, and/or high local rate of penicillin-nonsusceptible *S. pneumoniae*).<sup>1,27,101</sup> Initial therapy with a broader antibiotic targeting  $\beta$ -lactamase-producing organisms and resistant *S. pneumoniae* should be considered in the following circumstances: a history of poor response to amoxicillin; moderate-severe, complicated or potentially complicated disease (including frontal or sphenoidal involvement); protracted or recurrent disease; and high risk for antibiotic resistance (age <2 years, day care, recent antibiotic use).<sup>1,31,101,121</sup> Amoxicillin-clavulanic acid (80–90 mg/kg/day of amoxicillin component) is generally recommended in these situations and, in the ISDA guidelines, is preferred first-line therapy.<sup>1,101</sup> Alternatives include cephalosporins (e.g. cefuroxime, cefpodoxime, cefprozil, cefdinir, cefixime), combination cephalosporin with clindamycin to provide extended Gram-positive (e.g. *S. pneumoniae*, methicillin-susceptible and methicillin-resistant *S. aureus*) and anaerobic coverage, or the fluoroquinolone levofloxacin.<sup>1,101</sup> Macrolides (e.g. azithromycin) are generally not recommended because of increasing resistance of *S. pneumoniae* and *H. influenzae* unless other options are limited by allergies.<sup>1,27,101,121</sup> The role of trimethoprim-sulfamethoxazole has similarly been reduced by increasing resistance of both *S. pneumoniae* and *H. influenzae*; it remains an option in patients with  $\beta$ -lactam allergy or known infection with methicillin-resistant *Staphylococcus aureus*.<sup>1,27,28,101,121</sup>

TABLE 26-3

Selected Antibiotics for Acute, Subacute and Chronic Sinusitis

Antibiotic	Comments
Penicillins Amoxicillin Amoxicillin-clavulanate	Untreated, mild, uncomplicated disease; high dose targets resistant <i>Streptococcus pneumoniae</i> Poor response to amoxicillin; moderate-severe, complicated or protracted disease; or high risk for antibiotic resistance High dose of amoxicillin component targets resistant <i>S. pneumoniae</i>
Cephalosporins Cefuroxime Cefpodoxime Cefprozil Cefdinir Cefixime Cefotaxime Ceftriaxone	Poor response to amoxicillin or amoxicillin-clavulanate; moderate-severe, complicated or protracted disease; penicillin allergy; or high risk for antibiotic resistance. May be combined with clindamycin for additional Gram-positive ( <i>S. pneumoniae</i> , <i>S. aureus</i> , streptococci) coverage. Intravenous agents (cefotaxime, ceftriaxone) for severe or complicated disease or disease unresponsive to oral antibiotics
Macrolides Clarithromycin Azithromycin	Recommended only if significant $\beta$ -lactam allergy limits other options; increasing resistance of <i>S. pneumoniae</i> and <i>Haemophilus influenzae</i>
Trimethoprim-sulfamethoxazole	Recommended only if significant $\beta$ -lactam allergy limits other options or if known methicillin-resistant <i>Staphylococcus aureus</i> ; increasing resistance of <i>S. pneumoniae</i> and <i>H. influenzae</i>
Clindamycin	Activity against Gram-positive aerobes (including many <i>S. pneumoniae</i> , many methicillin-susceptible and methicillin-resistant <i>S. aureus</i> , and streptococci) and anaerobes; can be combined with cephalosporin to provide broad coverage; option if significant $\beta$ -lactam allergy or poor response to $\beta$ -lactam antibiotics
Levofloxacin	Fluoroquinolone antibiotic; option if severe penicillin allergy or poor response to $\beta$ -lactam antibiotics
Vancomycin	Intravenous; severe or complicated disease or disease unresponsive to oral antibiotics

If amoxicillin is chosen for initial therapy, lack of clinical response within 48 to 72 hours should prompt a change to a broader agent (e.g. amoxicillin-clavulanate).<sup>1,28,31</sup> If amoxicillin-clavulanate is used initially without clinical response, include either a combination of cephalosporin with clindamycin, or levofloxacin.<sup>1,101</sup> If the disease becomes severe, protracted, associated with orbital or intracranial complications, or unresponsive to multiple antibiotic trials, sinus lavage for microbiologic diagnosis and/or intravenous antibiotics (e.g. cefotaxime, ceftriaxone, vancomycin, clindamycin) can be considered.<sup>1,19,121</sup> In immunocompromised hosts, sinus lavage should be considered earlier because of their increased risk for atypical and resistant organisms and their impaired immune response to them.<sup>31,121</sup>

There has been no systematic evaluation of the optimal duration of antibiotic therapy for acute sinusitis in children. Data obtained in adults suggest that treatment for 10 days affords microbiologic cure rates in excess of 90%, whereas 7-day

courses are associated with microbiologic failure in 20%. However, treatment courses as short as 1 to 5 days in children have had encouraging clinical results in a limited number of trials.<sup>124–126</sup> In general, a 10- to 14-day treatment course is recommended for the majority of children, tailored to a patient's response (e.g. treat until asymptomatic plus an additional 7 days).<sup>1,31,101,121,127</sup> Longer courses (e.g. 3 to 4 weeks) should be considered for severe disease or if resolution is unusually slow.<sup>27,32,121,127</sup>

### Chronic Sinusitis

Few studies of the efficacy of antibiotics in hastening clinical improvement from and preventing complications of chronic sinusitis have been reported; furthermore, their findings are inconsistent. In atopic children with chronic sinusitis, amoxicillin and trimethoprim-sulfamethoxazole were associated with higher response rates than either erythromycin or an oral antihistamine/decongestant without antibiotic.<sup>128</sup> However, in other studies of subacute or chronic sinusitis, response rates with antibiotic therapy plus decongestant were not greater than those with decongestant plus nasal saline<sup>129</sup> or with placebo or drainage procedures.<sup>47</sup>

Despite lack of firm evidence of efficacy, antibiotics are generally prescribed for chronic sinusitis because pathogenic bacteria in the sinuses have been well documented. Broad-spectrum antibiotics are chosen for empirical therapy, with the choice dependent on previous treatments and anticipated resistance patterns of pathogens such as *S. pneumoniae*, *H. influenzae*, *M. catarrhalis* and *S. aureus* (see Table 26-3). Favorable options include amoxicillin-clavulanic acid, cefuroxime and third-generation cephalosporins such as cefpodoxime and cefdinir. If these agents are unsuccessful, a trial of clindamycin to target  $\beta$ -lactam-resistant *S. pneumoniae*, methicillin-susceptible and methicillin-resistant *S. aureus*, and anaerobes is reasonable.<sup>27,130,131</sup> Trimethoprim-sulfamethoxazole may be helpful for a patient with known infection with methicillin-resistant *S. aureus* resistant to clindamycin. The roles of oxazolidinones (e.g. linezolid) and newer fluoroquinolones such as levofloxacin for pediatric chronic sinusitis are yet to be determined. After multiple failed antibiotic courses, concern for resistant organisms increases, and sinus lavage for culture and susceptibilities should be considered to facilitate targeted antibiotic treatment.<sup>7,31,43,121,132</sup> Nasal swabs have insufficient positive predictive value to accurately guide antibiotic therapy.<sup>1,38,46,57,101,133</sup> Middle meatus swabs may have better, although still imperfect, correlation with sinus cultures.<sup>1,46,57,101,134</sup> Patients with very resistant isolates and/or extremely refractory disease may benefit from intravenous therapy with agents such as cefotaxime, ceftriaxone, cefuroxime, ampicillin-sulbactam, ticarcillin-clavulanate, piperacillin-tazobactam, vancomycin or clindamycin.<sup>43,121,132,135</sup> For invasive fungal sinusitis, surgical debridement and systemic antifungal therapy are indicated.<sup>136</sup>

The optimal duration of therapy is unknown. A minimum of 14 days is generally recommended if there is a prompt response. Longer courses (e.g. 3–6 weeks) can be considered for slower responses, and treatment for 7 days beyond the patient becoming symptom-free has been suggested.<sup>32,121,127</sup> It has been suggested that prolonged courses of intravenous antibiotics may be effective for treating bacteria in sinus-containing biofilms; however, this concept remains to be proven.<sup>17</sup>

Antibiotic prophylaxis with agents such as amoxicillin or sulfonamides was previously used for children with recurrent

sinusitis by analogy with recurrent otitis media.<sup>31,103</sup> An alternative approach was short-term, preemptive prophylaxis with the onset of URTIs in children who have frequently recurrent sinusitis triggered by URTIs, a strategy that was beneficial for recurrent otitis media.<sup>137</sup> However, increasing rates of antibiotic resistance and the resulting impetus to reduce antibiotic exposure have restricted prophylactic antibiotic strategies in recent years.<sup>32,138</sup>

## SINUS SURGERY

### Acute Sinusitis

The indications to perform sinus surgery on a child with acute and uncomplicated sinusitis are limited. Acute sinusitis symptoms are generally relieved by medical therapy consisting of antibiotics and adjunctive medical therapy. However, acute frontal or sphenoidal sinusitis in an adolescent may benefit from emergent surgical drainage for pain relief. In immunocompromised hosts, sinus irrigations to obtain specimens for microbial staining and culturing may be needed to identify potentially unusual, opportunistic pathogens.

### Chronic Sinusitis

Endoscopic sinus surgery (ESS) was popularized after sinus surgery using endoscopes was imported from Europe by American surgeons in the 1980s. The safety and efficacy of this procedure in pediatric sinusitis cases have been reported, based primarily on satisfaction questionnaires.<sup>139–141</sup> A meta-analysis using data from 13 studies on the outcomes of pediatric ESS concluded that ESS is a safe and effective treatment of chronic sinusitis in children.<sup>142</sup> However, it is important to note that the studies included in this analysis lack an untreated control group, and most of the data sources were retrospective chart reviews.

Others have reported symptomatic and clinical improvements following ESS in special populations such as children and adults with asthma<sup>143,144</sup> and cystic fibrosis,<sup>145</sup> although polyp recurrence in cystic fibrosis exceeds 50%.<sup>142</sup> Opposing this trend have been sporadic commentaries challenging the impression that pediatric sinusitis is a surgical disease.<sup>138,146</sup> Indeed, in a cohort of children who underwent ESS at an early age, a markedly higher rate of revision surgeries (50%) was required (e.g. for postsurgical osteomeatal scarring), in comparison with a control group of young, chronic sinusitis patients who had not had prior sinus surgery (9%).<sup>147</sup>

Despite its unproven clinical efficacy and uncertain indications, ESS has safety attributes that surpass those of its predecessors. ESS with pediatric instrumentation can provide sinus drainage and sinus ablation. Specifically, the ostium of the maxillary sinuses can be widened by endoscopic antrostomy. By performing endoscopic ethmoidectomy, the ethmoid cells and polypoid tissue can be removed, frontal duct drainage can be enhanced and the sphenoid sinus can be entered and drained. A technologic advance in ESS, balloon sinuplasty, uses angioplasty balloon technology to expand the sinus ostium to increase sinus aeration and/or establish drainage. The therapeutic benefit of balloon sinuplasty has not yet been determined.<sup>148</sup> However, the light angioplasty guide wire can be used to enter the frontal sinus for bacteriologic sampling and irrigation.

### Surgery for Sinusitis Complications

The type of sinusitis complication dictates whether an otolaryngologist will need the additional expertise of an



ophthalmologist or a neurosurgeon. Generally, the participation of a pediatrician or an infectious disease consultant in the care of a child with sinusitis complications is beneficial.

Subperiosteal and orbital abscesses can be drained through either an external or endoscopic approach. Small epidural abscesses may be treated medically. Other intracranial abscesses are usually drained by a neurosurgeon. Complicated frontal sinusitis (e.g. mucocele, osteomyelitis of the frontal bone) is treated through an external approach, with the intent to achieve drainage and debridement. Severe cases in which long-term antimicrobial therapy has failed may need sinus obliteration, cranialization and/or other reconstructive procedures. Mucoceles of the ethmoid and sphenoid sinuses can be drained endoscopically. Children with toxic shock syndrome from sinusitis should undergo sinus irrigation for culture and drainage. Neurosurgical drainage is sometimes indicated.

### Adjunctive Surgical Procedures

Adenoid hypertrophy is a cause of chronic sinusitis and the benefits of adenoidectomy for chronic sinusitis have been suggested by earlier uncontrolled studies.<sup>149,150</sup> A meta-analysis of 10 trials (six cohort and four case series) showed significant reduction of postoperative sinusitis symptoms.<sup>151</sup> The basis for improvement by adenoidectomy is unknown. No correlation between maxillary sinus and adenoid cultures in patients with chronic rhinosinusitis was found.<sup>16</sup> An abundance of bacterial biofilm coating the surface of adenoid surgical specimens in patients with chronic rhinosinusitis vs obstructive sleep apnea was observed.<sup>152</sup> Chronic sinusitis patients with nasal obstruction from adenoid hypertrophy are likely to have some symptomatic benefit from an adenoidectomy regardless of effects on the sinuses.

Some children with chronic sinusitis have inferior turbinate hypertrophy causing nasal obstruction. There are no published reports on the efficacy of inferior turbinate cauterization or reduction in the treatment of chronic sinusitis. In subjects in whom intranasal corticosteroid therapy for nasal obstructive symptoms associated with inferior turbinate hypertrophy has failed, a turbinate reduction procedure for symptomatic relief may be considered.

## ADJUNCTIVE MEDICAL THERAPY

Clinicians have used an assortment of agents in conjunction with oral antibiotics for the treatment of both acute and chronic sinusitis in children, including nasal saline washes (isotonic and hypertonic), topical and oral decongestants and antihista-

mines, topical anticholinergics, leukotriene receptor antagonists, topical anti-infectives and corticosteroids (intranasal and oral). The use of these agents is largely based on their theoretical benefits of improving associated rhinitis and rhinorrhea by decreasing mucosal inflammation, edema and mucous production, and increasing mucociliary transport, thereby improving nasal patency and presumably ostial drainage. They are generally discouraged in treating acute sinusitis in children.<sup>1,101</sup> Cochrane reviews addressing the efficacy of intranasal saline washes<sup>153</sup> and intranasal corticosteroids<sup>154</sup> for rhinosinusitis in adults concluded significant improvement by saline washes as monotherapy and in combination with intranasal corticosteroids for chronic sinusitis symptoms. For acute sinusitis, there was limited support for intranasal corticosteroids as monotherapy or in combination with oral antibiotics.<sup>154,155</sup> In adults with chronic rhinosinusitis with nasal polyposis, intranasal corticosteroids improved polyp scores and patients' symptoms, and reduced postoperative polyp recurrence.<sup>156</sup> Topical and systemic antifungal therapies have been purported to benefit patients with chronic rhinosinusitis. A recent systematic review with meta-analyses found no significant benefit and higher adverse event reporting in the antifungal-treated groups.<sup>157</sup>

## Conclusions

Sinusitis in children is a common problem. Diagnosis is challenging due to the overlap of symptoms, physical findings and radiographic findings with those of common URTIs. Sinusitis rarely leads to severe, life-threatening complications as a result of direct extension of bacterial infection from the sinuses. Management of uncomplicated, acute sinusitis consists of antimicrobial treatment aiming for symptom relief and prevention of complications and recurrence. Radiographic imaging studies (e.g. coronal sinus CT scans) may be helpful in chronic, recurrent or complicated sinusitis. Antral irrigation can provide sinus specimens for bacterial culture and targeted antimicrobial therapy in patients with chronic, refractory and complicated disease. Sinus surgery in uncomplicated sinusitis, especially in young children, should generally be avoided. Great reductions in mortality caused by sinusitis complications coincide with advances in antimicrobial and surgical therapies.

The complete reference list can be found on the companion Expert Consult website at <http://www.expertconsult.inkling.com>.

## KEY REFERENCES

- American Academy of Pediatrics. Clinical practice guideline for the diagnosis and management of acute bacterial sinusitis in children 1–18 years. *Pediatrics* 2013;132:e262–80.
- Gwaltney JMJ, Phillips CD, Miller RD, Riker DK. Computed tomographic study of the common cold. *N Engl J Med* 1994;330:25–30.
- Abreu NA, Nagalingam NA, Song Y, Roediger FC, Pletcher SD, Goldberg AN, et al. Sinus microbiome diversity depletion and *Corynebacterium tuberculostearicum* enrichment mediates rhinosinusitis. *Sci Transl Med* 2012;4:151ra124.
- Campbell JM, Graham M, Gray HC, Bower C, Blaiss MS, Jones SM. Allergic fungal sinusitis in children. *Ann Allergy Asthma Immunol* 2006;96:286–90.
- Chan KH, Abzug MJ, Coffinet L, Simoes EA, Cool C, Liu AH. Chronic rhinosinusitis in young children differs from adults: a histopathology study. *J Pediatr* 2004;144:206–12.
- Chow AW, Benninger MS, Brook I, Brozek JL, Goldstein EJ, Hicks LA, et al., Infectious Diseases Society of America. IDSA clinical practice guideline for acute bacterial rhinosinusitis in children and adults. *Clin Infect Dis* 2012; 54:e72–112.
- McAlister WH, Parker BR, Kushner DC, Babcock DS, Cohen HL, Gelfand MJ, et al. Sinusitis in the pediatric population: American College of Radiology. ACR appropriateness criteria. *Radiology* 2000;215(Suppl.):811–18.
- Chan KH, Winslow CP, Abzug MJ. Persistent rhinosinusitis in children following endoscopic sinus surgery. *Otolaryngol Head Neck Surg* 1999;121:577–80.
- Harvey R, Hannan SA, Badia L, Scadding G. Nasal saline irrigations for the symptoms of chronic rhinosinusitis. *Cochrane Database Syst Rev* 2007;3:CD006394.
- Zalmanovici A, Yaphe J. Intranasal steroids for acute sinusitis. *Cochrane Database Syst Rev* 2009;4:CD005149.

## REFERENCES

- American Academy of Pediatrics. Clinical practice guideline for the diagnosis and management of acute bacterial sinusitis in children 1–18 years. *Pediatrics* 2013;132:e262–80.
- Clement PA, Gordts F. Epidemiology and prevalence of aspecific chronic sinusitis. *Int J Pediatr Otorhinolaryngol* 1999;49:S101–3.
- Aitken M, Taylor JA. Prevalence of clinical sinusitis in young children followed up by primary care pediatricians. *Arch Pediatr Adolesc Med* 1998;152:244–8.
- Lombardi E, Stein RT, Wright AL, Morgan WJ, Martinez FD. The relation between physician-diagnosed sinusitis, asthma, and skin test reactivity to allergens in 8-year-old children. *Pediatr Pulmonol* 1996;22:141–6.
- McCaug LF, Hughes JM. Trends in antimicrobial drug prescribing among office-based physicians in the United States. *JAMA* 1995;273:214–19.
- Doern GV, Brueggemann AB, Huynh H, Wingert E. Antimicrobial resistance with *Streptococcus pneumoniae* in the United States, 1997–1998. *Emerg Infect Dis* 1999;5:757–65.
- Slack CL, Dahn KA, Abzug MJ, Chan KH. Antibiotic-resistant bacteria in pediatric chronic sinusitis. *Pediatr Infect Dis J* 2001;20:247–50.
- Cunningham JM, Chiu EJ, Landgraf JM, Gliklich RE. The health impact of chronic recurrent rhinosinusitis in children. *Arch Otolaryngol Head Neck Surg* 2000;126:1363–8.
- Parsons DS, Wald ER. Otitis media and sinusitis: similar diseases. *Otolaryngol Clin North Am* 1996;29:11–25.
- Swartz JD, Alper CM, Seroky JT, Chan KH, Doyle WJ. In vivo observation with magnetic resonance imaging of middle ear effusion in response to experimental underpressures. *Ann Otol Rhinol Laryngol* 1995;104:522–8.
- Piltcher OB, Swartz JD, Magnuson K, Alper CM, Doyle WJ, Hebda PA. A rat model of otitis media with effusion caused by eustachian tube obstruction with and without *Streptococcus pneumoniae* infection: methods and disease course. *Otolaryngol Head Neck Surg* 2002;126:490–8.
- Milczuk HA, Dalley HA, Wessbacher RW, Richardson MA. Nasal and paranasal sinus anomalies in children with chronic sinusitis. *Laryngoscope* 1993;103:247–52.
- Lusk RP, McAlister B, el Fouley A. Anatomic variation in pediatric chronic sinusitis: a CT study. *Otolaryngol Clin North Am* 1996;29:75–91.
- Al-Qudah M. The relationship between anatomical variations of the sinonasal region and chronic sinusitis extension in children. *Int J Pediatr Otorhinolaryngol* 2008;72:817–21.
- Kim HJ, Jung Cho M, Tae Kim Y, Kahng H, Sung Kim H, Hahm KH. The relationship between anatomic variations of paranasal sinuses and chronic sinusitis in children. *Acta Otolaryngol* 2006;126:1067–72.
- Tuncer U, Aydogan B, Soylu L, Simsek M, Akcali C, Kucukcan A. Chronic rhinosinusitis and adenoid hypertrophy in children. *Am J Otolaryngol* 2004;25:5–10.
- Novembre E, Mori F, Pucci N, Bernardini R, Vierucci A, de Martino M. Systemic treatment of rhinosinusitis in children. *Pediatr Allergy Immunol* 2007;18(Suppl. 18):56–61.
- Puhakka T, Makela MJ, Alanen A, et al. Sinusitis in the common cold. *J Allergy Clin Immunol* 1998;102:403–8.
- Gwaltney MJ, Phillips CD, Miller RD, Riker DK. Computed tomographic study of the common cold. *N Engl J Med* 1994;330:25–30.
- Plouin-Gaudon I, Clement S, Huggler E, Chaponnier C, François P, Lew D, et al. Intracellular residency is frequently associated with recurrent *Staphylococcus aureus* rhinosinusitis. *Rhinology* 2006;44:249–54.
- Brook I. Current issues in the management of acute bacterial sinusitis in children. *Int J Pediatr Otorhinol* 2007;71:1653–61.
- Sandlemel JA, Webster P, Thomas J, Ramadan HH. Bacterial biofilms in surgical specimens of patients with chronic rhinosinusitis. *Laryngoscope* 2005;115:578–82.
- Harvey RJ, Lund VJ. Biofilms and chronic rhinosinusitis: systematic review of evidence, current concepts and directions for research. *Rhinology* 2007;45:3–13.
- Bolger WE, Leonard D, Dick EJ Jr, Stierna P. Gram negative sinusitis: a bacteriologic and histologic study in rabbits. *Am J Rhinol* 1997;11:15–25.
- Gwaltney JM. Principles and practice of infectious diseases. Philadelphia: Churchill Livingstone; 2000.
- Wald ER, Milmoie GJ, Bowen A, Ledesma-Medina J, Salamon N, Bluestone CD. Acute maxillary sinusitis in children. *N Engl J Med* 1981;304:749–54.
- Brook I, Gooch WM 3rd, Jenkins SG, Pichichero ME, Reiner SA, Sher L, et al. Medical management of acute bacterial sinusitis. *Ann Otol Rhinol Laryngol* 2000;109:S2–20.
- Sinus and Allergy Health Partnership. Antimicrobial treatment guidelines for acute bacterial rhinosinusitis. *Otolaryngol Head Neck Surg* 2000;123:S1–32.
- Tinkleman DG, Silk HJ. Clinical and bacteriologic features of chronic sinusitis in children. *Am J Dis Child* 1989;143:938–41.
- Wald ER, Byers C, Guerra N, Casselbrant M, Beste D. Subacute sinusitis in children. *J Pediatr* 1989;115:28–32.
- Wald ER. Sinusitis. *Pediatr Ann* 1998;27:811–18.
- Principi N, Esposito S. New insights into pediatric rhinosinusitis. *Pediatr Allergy Immunol* 2007;18(Suppl. 18):7–9.
- Rankhethoa NM, Prescott CA. Significance of *Streptococcus milleri* in acute rhinosinusitis with complications. *J Laryngol Otol* 2008;122:810–13.
- Hwang SY, Tan KK. *Streptococcus viridans* has a leading role in rhinosinusitis complications. *Ann Otol Rhinol Laryngol* 2007;116:381–5.
- Brook I, Frazier EH, Gher ME. Microbiology of periapical abscesses and associated maxillary sinusitis. *J Periodontol* 1996;67:608–10.
- Kim SY, Syms MJ, Holtel MR, Nauschuetz KK. *Acanthamoeba* sinusitis with subsequent dissemination in an AIDS patient. *Ear Nose Throat J* 2000;79:168–74.
- Teknos TN, Poulin MD, Laruentano AM, Li KK. *Acanthamoeba* rhinosinusitis: characterization, diagnosis, and treatment. *Am J Rhinol* 2000;14:387–91.
- Arruda LK, Mimica IM, Solé D, Weckx LL, Schoettler J, Heiner DC, et al. Abnormal maxillary sinus radiographs in children: do they represent bacterial infection? *Pediatrics* 1990;85:553–8.
- Marom T, Alvarez-Fernandez PE, Jennings K, Patel JA, McCormick DP, Chonmaitree T. Acute bacterial sinusitis complicating viral upper respiratory tract infection in young children. *Pediatr Infect Dis J* 2014;33:803–8.
- Cho GS, Moon BJ, Lee BJ, Gong CH, Kim NH, Kim YS, et al. High rates of detection of respiratory viruses in the nasal washes and mucosae of patients with chronic rhinosinusitis. *J Clin Microbiol* 2013;51:979–84.
- Steele RW. Chronic sinusitis in children. *Clin Pediatr* 2005;44:465–71.
- Brook I. Bacteriologic features of chronic sinusitis in children. *JAMA* 1981;246:967–9.
- Don DM, Yellon RE, Casselbrant ML, Bluestone CD. Efficacy of a stepwise protocol that includes intravenous antibiotic therapy for the management of chronic sinusitis in children and adolescents. *Arch Otolaryngol Head Neck Surg* 2001;127:1093–8.
- Erkan M, Ozcan M, Arslan S, Soysal V, Bozdemir K, Haghghi N. Bacteriology of antrum in children with chronic maxillary sinusitis. *Scand J Infect Dis* 1996;28:283–5.
- Muntz HR, Lusk RP. Bacteriology of the ethmoid bullae in children with chronic sinusitis. *Arch Otolaryngol Head Neck Surg* 1991;117:179–81.
- Orobellow PW, Park RI, Belcher LJ, Eggleston P, Lederman HM, Banks JR, et al. Microbiology of chronic sinusitis in children. *Arch Otolaryngol Head Neck Surg* 1991;117:980–3.
- Otten FWA, Grote JJ. Treatment of chronic maxillary sinusitis in children. *Int J Pediatr Otorhinolaryngol* 1988;15:269–78.
- Brook I, Frazier EH, Foote PA. Microbiology of the transition from acute to chronic maxillary sinusitis. *J Med Microbiol* 1996;45:372–5.
- Brook I, Yocum P, Frazier EH. Bacteriology and beta-lactamase activity in acute and chronic maxillary sinusitis. *Arch Otolaryngol Head Neck Surg* 1996;122:418–23.
- Brook I, Frazier EH. Microbiology of subperiosteal orbital abscess and associated maxillary sinusitis. *Laryngoscope* 1996;106:1010–13.
- Frederick J, Braude A. Anaerobic infection of the paranasal sinuses. *N Engl J Med* 1974;290:135–7.
- Brook I, Foote PA, Hausefeld JN. Increase in the frequency of recovery of methicillin-resistant *Staphylococcus aureus* in acute and chronic maxillary sinusitis. *J Med Microbiol* 2008;57:1015–17.
- Brook I. Bacteriology of chronic maxillary sinusitis in adults. *Ann Otol Rhinol Laryngol* 1989;98:426–8.
- Erkan M, Aslan T, Ozcan M, Koç N. Bacteriology of antrum in adults with chronic maxillary sinusitis. *Laryngoscope* 1994;104:321–4.
- Brook I. Chronic sinusitis in children and adults: role of bacteria and antimicrobial management. *Curr Allergy Asthma Rep* 2005;5:482–90.
- Abreu NA, Nagalingam NA, Song Y, Roediger FC, Pletcher SD, Goldberg AN, et al. Sinus microbiome diversity depletion and *Corynebacterium tuberculostrictum* enrichment mediates rhinosinusitis. *Sci Transl Med* 2012;4:151ra124.
- Chan KH, Liu A, Abzug MJ, et al. Unpublished data.

58. Ramadan HH, Farr RW, Wetmore SJ. Adenovirus and respiratory syncytial virus in chronic sinusitis using polymerase chain reaction. *Laryngoscope* 1977;107:923-5.
59. Van Nostrand AWP, Goodman WS. Pathologic aspects of mucosal lesions of the maxillary sinus. *Otolaryngol Clin North Am* 1976;9:21-7.
60. Rochester CL, Ackerman SJ, Zheng T, Elias JA. Eosinophil-fibroblast interactions: granule major basic protein interacts with IL-1 and transforming growth factor-beta in the stimulation of lung fibroblast IL-6-type cytokine production. *J Immunol* 1996;156:4449-56.
61. Broide DH, Paine MM, Firestein GS. Eosinophils express interleukin 5 and granulocyte macrophage-colony-stimulating factor mRNA at sites of allergic inflammation in asthmatics. *J Clin Invest* 1992;90:1414-24.
62. Kita H, Ohnishi T, Okubo Y, Weiler D, Abrams JS, Gleich GJ. Granulocyte/macrophage colony-stimulating factor and interleukin 3 release from human peripheral blood eosinophils and neutrophils. *J Exp Med* 1991;174:745-8.
63. Minshall E, Chakir J, Laviolette M, Molet S, Zhu Z, Olivenstein R, et al. IL-11 expression is increased in severe asthma: association with epithelial cells and eosinophils. *J Allergy Clin Immunol* 2000;105:232-8.
64. Durham SR, Ying S, Varney VA, Jacobson MR, Sudderick RM, Mackay IS, et al. Cytokine messenger RNA expression for IL-3, IL-4, IL-5 and granulocyte/macrophage-colony-stimulating factor in the nasal mucosa after local allergen provocation: relationship to tissue eosinophilia. *J Immunol* 1992;148:2390-4.
65. Hamilos DL, Leung DYM, Wood R, Cunningham L, Bean DK, Yasruel Z, et al. Evidence for distinct cytokine expression in allergic versus nonallergic chronic sinusitis. *J Allergy Clin Immunol* 1995;96:537-44.
66. Rachelefsky GS. Chronic sinusitis: a disease of all ages. *Am J Dis Child* 1989;143:886-8.
67. Varney VA, Jacobson MR, Sudderick RM, Robinson DS, Irani AM, Schwartz LB, et al. Immunohistology of the nasal mucosa following allergen-induced rhinitis: identification of activated T lymphocytes, eosinophils and neutrophils. *Am Rev Respir Dis* 1992;146:170-6.
68. Settapan GA. Epidemiology of nasal polyps. *Allergy Asthma Proc* 1996;17:231-6.
69. Baroody FM, Hughes T, McDowell PR, Hruban R, Zinreich SJ, Naclerio RM. Eosinophilia in chronic childhood sinusitis. *Arch Otolaryngol Head Neck Surg* 1995;121:1396-402.
70. Demoly P, Crampette L, Mondain M, Campbell AM, Lequeux N, Enander I, et al. Assessment of inflammation in noninfectious chronic maxillary sinusitis. *J Allergy Clin Immunol* 1994;94:95-108.
71. Wright ED, Frenkiel S, Al-Ghamdi K, Ghaffar O, Small P, Trout T, et al. Interleukin-4, interleukin-5, and granulocyte-macrophage colony-stimulating factor receptor expression in chronic sinusitis and response to topical steroids. *Otolaryngol Head Neck Surg* 1998;118:490-5.
72. Hamilos DL, Leung DYM, Wood R, Meyers A, Stephens JK, Barkans J, et al. Chronic hyperplastic sinusitis: association of tissue eosinophilia with mRNA expression of granulocyte-macrophage colony-stimulating factor and interleukin-3. *J Allergy Clin Immunol* 1993;92:39-48.
73. Hamilos DL. Chronic sinusitis. *J Allergy Clin Immunol* 2000;106:213-27.
74. Demoly P, Crampette L, Mondain M, Enander I, Jones I, Bousquet J. Myeloperoxidase and interleukin-8 levels in chronic sinusitis. *Clin Exp Allergy* 1997;27:672-5.
75. Schubert MS, Goetz DW. Evaluation and treatment of allergic fungal sinusitis. II. Treatment and follow-up. *J Allergy Clin Immunol* 1998;102:395-402.
76. Schubert MS, Goetz DW. Evaluation and treatment of allergic fungal sinusitis. I. Demographics and diagnosis. *J Allergy Clin Immunol* 1998;102:387-94.
77. Manning SC, Vuitch F, Weinberg AG, Brown OE. Allergic aspergillosis: a newly recognized form of sinusitis in the pediatric population. *Laryngoscope* 1989;99:681-5.
78. Kupferberg SB, Bent JP. Allergic fungal sinusitis in the pediatric population. *Arch Otolaryngol Head Neck Surg* 1996;122:1381-4.
79. Campbell JM, Graham M, Gray HC, Bower C, Blaiss MS, Jones SM. Allergic fungal sinusitis in children. *Ann Allergy Asthma Immunol* 2006;96:286-90.
80. Andes D, Proctor R, Bush RK, Pasic TR. Report of successful prolonged antifungal therapy for refractory allergic fungal sinusitis. *Clin Infect Dis* 2000;31:202-4.
81. Seiberling K, Wormald PJ. The role of itraconazole in recalcitrant fungal sinusitis. *Am J Rhinol Allergy* 2009;23:303-6.
82. Chan KH, Abzug MJ, Coffinet L, Simoes EA, Cool C, Liu AH. Chronic rhinosinusitis in young children differs from adults: a histopathology study. *J Pediatr* 2004;144:206-12.
83. Coffinet L, Chan KH, Abzug MJ, Simoes EA, Cool C, Liu AH. Immunopathology of chronic rhinosinusitis in young children. *J Pediatr* 2009;154:754-8.
84. Jarvis D, Newson R, Lotvall J, Hastan D, Tomassen P, Keil T, et al. Asthma in adults and its association with chronic rhinosinusitis: the GA2LEN survey in Europe. *Allergy* 2012;67:91-8.
85. Zimmerman B, Stinger D, Feanny S, Reisman J, Hak H, Rashed N, et al. Prevalence of abnormalities found by sinus X-rays in childhood asthma: lack of relation to severity of asthma. *J Allergy Clin Immunol* 1987;80:268-73.
86. Rossi OVJ, Pirila T, Laitinen J, Huhti E. Sinus aspirates and radiographic abnormalities in severe attacks of asthma. *Int Arch Allergy Immunol* 1994;103:209-13.
87. Newman LJ, Platts-Mills TAE, Phillips CD, Hazen KC, Gross CW. Chronic sinusitis: relationship of computed tomographic findings to allergy, asthma, and eosinophilia. *JAMA* 1994;271:363-7.
88. Pelikan Z, Pelikan-Filipek M. Role of nasal allergy in chronic maxillary sinusitis-diagnostic value of nasal challenge with allergen. *J Allergy Clin Immunol* 1990;86:484-91.
89. Wang X, Moylan B, Leopold DA, Kim J, Rubenstein RC, Togias A, et al. Mutation in the gene responsible for cystic fibrosis and predisposition to chronic rhinosinusitis in the general population. *JAMA* 2000;284:1814-19.
90. Raman V, Clary R, Siegrist KL, Zehnbauser B, Chatila TA. Increased prevalence of mutations in the cystic fibrosis transmembrane conductance regulator in children with chronic rhinosinusitis. *Pediatrics* 2002;109:E13.
91. Castellani C, Quinzii C, Altieri S, Mastella G, Assael BM. A pilot survey of cystic fibrosis clinical manifestations in CFTR mutation heterozygotes. *Genet Test* 2001;5:249-54.
92. Bernstein J, Anon JB, Rontal M, Conroy J, Wang C, Sucheston L. Genetic polymorphisms in chronic hyperplastic sinusitis with nasal polyposis. *Laryngoscope* 2009;119:1258-64.
93. de Alarcon A, Steinke JW, Caughey R, Berekzi E, Hise K, Gross CW, et al. Expression of leukotriene C4 synthase and plasminogen activator inhibitor 1 gene promoter polymorphisms in sinusitis. *Am J Rhinol* 2006;20:545-9.
94. Kim SH, Park HS, Holloway JW, Shin HD, Park CS. Association between a THFbeta1 promoter polymorphism and rhinosinusitis in aspirin-intolerant asthmatic patients. *Respir Med* 2007;101:490-5.
95. Takeuchi K, Majima Y, Shimizu T. Tumor necrosis factor gene polymorphism in chronic sinusitis. *Laryngoscope* 2000;110:1711-14.
96. Takeuchi K, Majima Y, Shimizu T, Ukai K, Sakakura Y. Analysis of HLA antigens in Japanese patients with chronic sinusitis. *Laryngoscope* 1999;109:275-8.
97. Henmyr V, Vandeplas G, Halldén C, Säll T, Olze H, Bachert C, et al. Replication study of genetic variants associated with chronic rhinosinusitis and nasal polyposis. *J Allergy Clin Immunol* 2014;133:273-5.
98. Contencin P, Narcy P. Nasopharyngeal pH monitoring in infants and children with chronic rhinopharyngitis. *Int J Pediatr Otorhinolaryngol* 1991;22:249-56.
99. Yellon RF, Cotichchia J, Dixit S. Esophageal biopsy for the diagnosis of gastroesophageal reflux-associated otolaryngologic problems in children. *Am J Med* 2000;108:1315-1385.
100. Phipps CD, Wood WE, Gibson WS, Gibson WS, Cochran WJ. Gastroesophageal reflux contributing to chronic sinus disease in children: a prospective analysis. *Arch Otolaryngol Head Neck Surg* 2000;126:831-6.
101. Chow AW, Benninger MS, Brook I, Brozek JL, Goldstein EJ, Hicks LA, et al. Infectious Diseases Society of America. IDSA clinical practice guideline for acute bacterial rhinosinusitis in children and adults. *Clin Infect Dis* 2012;54:e72-112.
102. Slavin RG, Spector SL, Bernstein IL, Kaliner MA, Kennedy DW, Virant FS, et al. The diagnosis and management of sinusitis: a practice parameter update. *J Allergy Clin Immunol* 2005;116(6 Suppl.):S13-47.
103. Chan KH, Winslow CP, Levin MJ, Abzug MJ, Shira JE, Liu AH, et al. Clinical practice guidelines for the management of chronic sinusitis in children. *Otolaryngol Head Neck Surg* 1999;120:328-34.
104. Mudgil SP, Wise SW, Hopper KD, Kasales CJ, Mauger D, Fornadley JA. Correlation between presumed sinusitis-induced pain and paranasal sinus computed tomographic findings. *Ann Allergy Asthma Immunol* 2002;88:223-6.
105. McAlister WH, Parker BR, Kushner DC, Babcock DS, Cohen HL, Gelfand MJ, et al. Sinusitis in the pediatric population: American College of Radiology. ACR appropriateness criteria. *Radiology* 2000;215(Suppl.):811-18.
106. Garcia DP, Corbett ML, Eberly SM, Joyce MR, Le HT, Karibo JM, et al. Radiographic imaging studies in pediatric chronic sinusitis. *J Allergy Clin Immunol* 1994;94:523-30.
107. Lerner DN, Choi SS, Zalzal GH, Johnson DL. Intracranial complications of sinusitis in childhood. *Ann Otol Rhinol Laryngol* 1995;104:288-93.



108. Garcia CE, Cunningham MJ, Clary RA, Joseph MP. The etiologic role of frontal sinusitis in pediatric orbital abscesses. *Am J Otolaryngol* 1993;14:449–52.
109. Chandler JR, Lanenbrunner DJ, Steven ER. The pathogenesis of orbital complications in acute sinusitis. *Laryngoscope* 1970;141:1414–28.
110. Samad I, Riding K. Orbital complications of ethmoiditis: B.C. Children's Hospital experience. *J Otolaryngol* 1991;20:400–3.
111. Wald ER, Chiponis D, Ledesma-Medina J. Comparative effectiveness of amoxicillin and amoxicillin-clavulanate potassium in acute paranasal sinus infections in children: a double-blind, placebo-controlled trial. *Pediatrics* 1986;77:795–800.
112. Garbutt JM, Goldstein M, Gellman E, Shannon W, Littenberg B. A randomized, placebo-controlled trial of antimicrobial treatment for children with clinically diagnosed acute sinusitis. *Pediatrics* 2001;107:619–25.
113. Kristo A, Uhari M, Luotonen J, Ilkko E, Koivunen P, Alho OP. Cefuroxime axetil versus placebo for children with acute respiratory infection and imaging evidence of sinusitis: a randomized, controlled trial. *Acta Paediatr* 2005;94:1208–13.
114. Wald ER, Nash D, Eickhoff J. Effectiveness of amoxicillin/clavulanate potassium in the treatment of acute bacterial sinusitis in children. *Pediatrics* 2009;124:9–15.
115. Benninger MS, Sedory Holzer SE, Lau J. Diagnosis and treatment of uncomplicated acute bacterial rhinosinusitis: summary of the Agency for Health Care Policy and Research evidence-based report. *Otolaryngol Head Neck Surg* 2000;122:1–7.
116. Ahuvoo-Saloranta A, Borisenko OV, Kovanen N, Varonen H, Rautakorpi UM, Williams JW Jr, et al. Antibiotics for acute maxillary sinusitis. *Cochrane Database Syst Rev* 2008;2:CD000243.
117. Young J, De Sutter A, Merenstein D, van Essen GA, Kaiser L, Varonen H, et al. Antibiotics for adults with clinically diagnosed acute rhinosinusitis: a meta-analysis of individual patient data. *Lancet* 2008;371:908–14.
118. de Ferranti SD, Ioannidis JP, Lau J, Anninger WV, Barza M. Are amoxicillin and folate inhibitors as effective as other antibiotics for acute sinusitis? A meta-analysis. *Br Med J* 1998;317:632–7.
119. Falagas ME, Giannopoulou KP, Vardakas KZ, Dimopoulos G, Karageorgopoulos DE. Comparison of antibiotics with placebo for treatment of acute sinusitis: a meta-analysis of randomized controlled trials. *Lancet Infect Dis* 2008;8:543–52.
120. Piccirillo JF, Mager DE, Frisse ME, Brophy RH, Goggin A. Impact of first-line vs second-line antibiotics for the treatment of acute uncomplicated sinusitis. *JAMA* 2001;286:1849–56.
121. Clement PAR, Bluestone CD, Gordts F, Lusk RP, Otten FW, Goossens H, et al. Management of rhinosinusitis in children. *Arch Otolaryngol Head Neck Surg* 1998;124:31–4.
122. Williams JW Jr, Aguilar C, Makela M, Cornell J, Holleman DR, Chiquette E, et al. Antibiotics for acute maxillary sinusitis. *Cochrane Database Syst Rev* 2000;2:CD000243.
123. Williams JW Jr, Aguilar C, Makela M. Which antibiotics lead to higher clinical cure rates in adults with acute maxillary sinusitis? *West J Med* 2000;173:42.
124. Ng DK, Chow PY, Leung I, Chau KW, Chan E, Ho JC. A randomized controlled trial of azithromycin and amoxicillin/clavulanate in the management of sub-acute rhinosinusitis. *J Paediatr Child Health* 2000;36:378–81.
125. Pichichero M. Short course antibiotic therapy for respiratory infections: a review of the evidence. *Pediatr Infect Dis J* 2000;19:929–37.
126. Alagic-Smailbegovic J, Saracevic E, Sutalo K. Azithromycin versus amoxicillin-clavulanate in the treatment of acute sinusitis in children. *Bosn J Basic Med Sci* 2006;6:76–8.
127. Zacharisen MC, Kelly KJ. Allergic and infectious pediatric sinusitis. *Pediatr Ann* 1998;27:759–66.
128. Rachelefsky GS. Chronic sinusitis in children with respiratory allergy: the role of antimicrobials. *J Allergy Clin Immunol* 1982;69:382–7.
129. Dohlman AW, Hemstreet MP, Odrezin GT, Bartolucci AA. Subacute sinusitis: are antimicrobials necessary? *J Allergy Clin Immunol* 1993;91:1015–23.
130. Brook I, Yocum P. Antimicrobial management of chronic sinusitis in children. *J Laryngol Otol* 1995;109:1159–62.
131. Bussey MF. Acute sinusitis. *Pediatr Rev* 1999;20:142.
132. Buchman CA, Yellon RF, Bluestone CD. Alternative to endoscopic sinus surgery in the management of pediatric chronic rhinosinusitis refractory to oral antimicrobial therapy. *Otolaryngol Head Neck Surg* 1999;120:219–24.
133. Sener B, Hascelik G, Onerci M, Tunçkanat F. Evaluation of the microbiology of chronic sinusitis. *J Laryngol Otol* 1996;110:547–50.
134. Vogan JC, Bolger WE, Keyes AS. Endoscopically guided sinonasal cultures: a direct comparison with maxillary sinus aspirate cultures. *Otolaryngol Head Neck Surg* 2000;122:370–3.
135. Adappa ND, Coticchia JM. Management of refractory chronic rhinosinusitis in children. *Am J Otolaryngol* 2006;27:384–9.
136. Rizk SS, Kraus DH, Gerresheim G, Mudan S. Aggressive combination treatment for invasive fungal sinusitis in immunocompromised patients. *Ear Nose Throat J* 2000;79:278–80, 282, 284–5.
137. Prellner K, Fogle-Hansson M, Jorgensen F. Prevention of recurrent acute otitis media in otitis-prone children by intermittent prophylaxis with penicillin. *Acta Otolaryngol* 1994;114:182–7.
138. Baroody FM. Pediatric sinusitis. *Arch Otolaryngol Head Neck Surg* 2001;127:1099–101.
139. Parsons DS, Phillips SE. Functional endoscopic surgery in children: a retrospective analysis of results. *Laryngoscope* 1993;103:899–903.
140. Lazar RH, Younis RT, Long TE. Functional endonasal sinus surgery in adults and children. *Laryngoscope* 1993;103:1–5.
141. Gross CW, Gurucharri MJ, Lazar RH, Long TE. Functional endonasal sinus surgery (FESS) in the pediatric age group. *Laryngoscope* 1989;99:272–5.
142. Vlastarakos PV, Fetta M, Segas JV, Maragoudakis P, Nikolopoulos TP. Functional endoscopic sinus surgery improves sinus-related symptoms and quality of life in children with chronic rhinosinusitis: a systematic analysis and meta-analysis of published interventional studies. *Clin Pediatr (Phila)* 2013;52:1091–7.
143. Manning SC, Wasserman RL, Silver R, Phillips DL. Results of endoscopic sinus surgery in pediatric patients with chronic sinusitis and asthma. *Arch Otolaryngol Head Neck Surg* 1994;120:1142–5.
144. Vashishta R, Soler ZM, Nguyen SA, Schlosser RJ. A systematic review and meta-analysis of asthma outcomes following endoscopic sinus surgery for chronic rhinosinusitis. *Int Forum Allergy Rhinol* 2013;3:788–94.
145. Rosbe KW, Jones DT, Rahbar R, Lahiri T, Auerbach AD. Endoscopic sinus surgery in cystic fibrosis: do patients benefit from surgery? *Int J Pediatr Otorhinolaryngol* 2001;61:113–19.
146. Poole MD. Pediatric sinusitis is not a surgical disease. *Ear Nose Throat J* 1992;71:622–3.
147. Chan KH, Winslow CP, Abzug MJ. Persistent rhinosinusitis in children following endoscopic sinus surgery. *Otolaryngol Head Neck Surg* 1999;121:577–80.
148. Sedaghat AR, Cunningham MJ. Does balloon catheter sinuplasty have a role in the surgical management of pediatric sinus disease? *Laryngoscope* 2011;121:2053–4.
149. Vandenberg SJ, Heatley DG. Efficacy of adenoidectomy in relieving symptoms of chronic sinusitis in children. *Arch Otolaryngol Head Neck Surg* 1997;123:675–8.
150. Rosenfeld RM. Pilot study of outcomes in pediatric rhinosinusitis. *Arch Otolaryngol Head Neck Surg* 1995;121:729–36.
151. Brietzke SE, Brigger MT. Adenoidectomy outcomes in pediatric rhinosinusitis: a meta-analysis. *Int J Pediatr Otorhinolaryngol* 2008;72:1541–5.
152. Coticchia J, Zuliani G, Coleman C, Carron M, Gurrola J 2nd, Hauptert M, et al. Biofilm surface area in the pediatric nasopharynx: chronic rhinosinusitis vs obstructive sleep apnea. *Arch Otolaryngol Head Neck Surg* 2007;133:110–14.
153. Harvey R, Hannan SA, Badia L, Scadding G. Nasal saline irrigations for the symptoms of chronic rhinosinusitis. *Cochrane Database Syst Rev* 2007;3:CD006394.
154. Zalmanovici A, Yaphe J. Intranasal steroids for acute sinusitis. *Cochrane Database Syst Rev* 2009;4:CD005149.
155. Dolor RJ, Witsell DL, Hellkamp AS, Williams JW Jr, Califf RM, Simel DL, et al. Comparison of cefuroxime with or without intranasal fluticasone for the treatment of rhinosinusitis. The CAF trial: a randomized controlled trial. *JAMA* 2001;286:3097–105.
156. Kalish L, Snidvongs K, Sivasubramaniam R, Cope D, Harvey RJ. Topical steroids for nasal polyps. *Cochrane Database Syst Rev* 2012;12:CD006549.
157. Sacks PL, Harvey RJ, Rimmer J, Gallagher RM, Sacks R. Topical and systemic antifungal therapy for the symptomatic treatment of chronic rhinosinusitis. *Cochrane Database Syst Rev* 2011;8:CD008263.



# Chronic Cough

HENRY MILGROM

## KEY POINTS

- Cough is an important defense mechanism.
- Cough is a common manifestation of disease in childhood.
- Cough may be classified as acute (lasting <3 weeks), subacute (lasting 3 to 8 weeks), or chronic (lasting >8 weeks).
- The cause of chronic cough can be determined in most patients; specific therapy based on a systematic evaluation is usually successful.
- Congenital anomalies and aspiration are relatively uncommon causes of chronic cough in children.

## Introduction

Cough is a widespread sign and symptom of diseases ranging from uncomplicated respiratory tract infections to serious illnesses affecting several organ systems. It is a source of discomfort for the young patient and anxiety for the parents.<sup>1,2</sup> In the years 1995–1996, 24 million annual physician visits for cough took place in the USA, the largest number documented for a single symptom.<sup>3</sup> Nearly half the patients were younger than 15 years old. In this young cohort, cough accounted for 8.5% of all medical appointments.<sup>3</sup> Pediatric texts generally describe chronic cough as a condition that persists for more than 3 weeks. This observation suggests that chronic cough is likely to improve in time without treatment.<sup>4</sup> A better informed classification by Irwin and colleagues divides cough into three categories: acute, lasting less than 3 weeks; subacute, lasting 3 to 8 weeks; and chronic, lasting more than 8 weeks.<sup>5</sup> Irwin's definition of chronic cough excludes most self-limiting cases. A chronic cough by these criteria often lasts much longer than 8 weeks and requires medical attention.

Viral infections of the upper respiratory tract are the most common causes of acute cough. Typically, the symptoms resolve within 10 to 14 days.<sup>6</sup> Patients with subacute cough most often have a history of recent upper respiratory tract infection or seasonal allergic rhinitis (e.g. postinfectious cough, bacterial sinusitis and asthma). Children with chronic or recurrent episodes of dry, nonproductive cough over several months, require careful and systematic evaluation for the presence of specific diagnostic indicators.<sup>7</sup> They pose a perplexing problem in pediatric practice and call for a careful evaluation. Cough may be a manifestation of an underlying disorder that must be identified and treated. Many children with chronic cough have experienced repeated treatment failures, and the families have come to regard the condition as permanent and untreatable.

Fortunately, in most cases, this presupposition is inaccurate, but a systematic approach to the diagnosis is necessary, and therapy, to be effective, may have to be directed simultaneously at more than one involved cough mechanism. Evidence-based algorithms to manage the chronic cough of children based on validated outcome measures and a priori definitions to designate resolution should be put to use.<sup>8,9</sup> Child-specific cough management protocols are advocated in Australia, the USA and the UK.<sup>6</sup>

## Differential Diagnosis (Figure 27-1, Box 27-1)

The differential diagnosis of cough in childhood varies with the age of the patient, the duration, character and time of occurrence of the cough, associated signs and symptoms, and the patient's exposure history. In the neonatal period, congenital abnormalities, especially pulmonary or cardiac, must be considered. Prematurity, especially in a patient who had required mechanical ventilation, may lead to bronchopulmonary dysplasia or the development of tracheal or bronchial stenosis. Vomiting and regurgitation may be the presenting signs and symptoms of gastroesophageal reflux (GER) or a tracheoesophageal fistula. Recurrent choking or cough associated with difficulty in sucking or swallowing suggests aspiration. Cough may occur in the course or following resolution of a respiratory infection. Attendance in daycare increases the risk of upper respiratory symptoms and infections in young children. In the toddler, foreign body aspiration and cystic fibrosis are added to the list of causes. A history of fever and/or presentation in winter suggests a viral etiology; seasonal occurrence suggests asthma or seasonal allergic rhinitis; year-round symptoms suggest perennial allergic rhinitis. Maternal smoking, in particular, appears to influence the development of respiratory symptoms in young children.<sup>10</sup> In the older child, immune deficiency, tuberculosis and psychogenic cough enter into the differential diagnosis. Sinusitis, postnasal drip and GER may contribute to cough at any age. Cigarette smoking and psychogenic causes also require consideration among adolescents.<sup>11</sup> A recent study showed that in otherwise healthy children with unexplained chronic cough, a significant proportion of the coughs was preceded by episodes of reflux. Most of these episodes were acidic in older children but not in infants<sup>12</sup> (Figure 27-3). Early evaluation and treatment of children with recurrent cough, sinusitis, foreign-body aspiration or GER are important to prevent bronchiectasis.<sup>13</sup>

How often do normal children cough? Accurate answers come from studies that used cough recorders. Cough frequency over 24 hours was 11.3, with a range of one to 34 in 41 children free from respiratory infection for at least 1 month. Only two children coughed at night.<sup>14</sup> In children with chronic cough, the frequency was 65/day and in normal controls 10/day.<sup>15</sup>

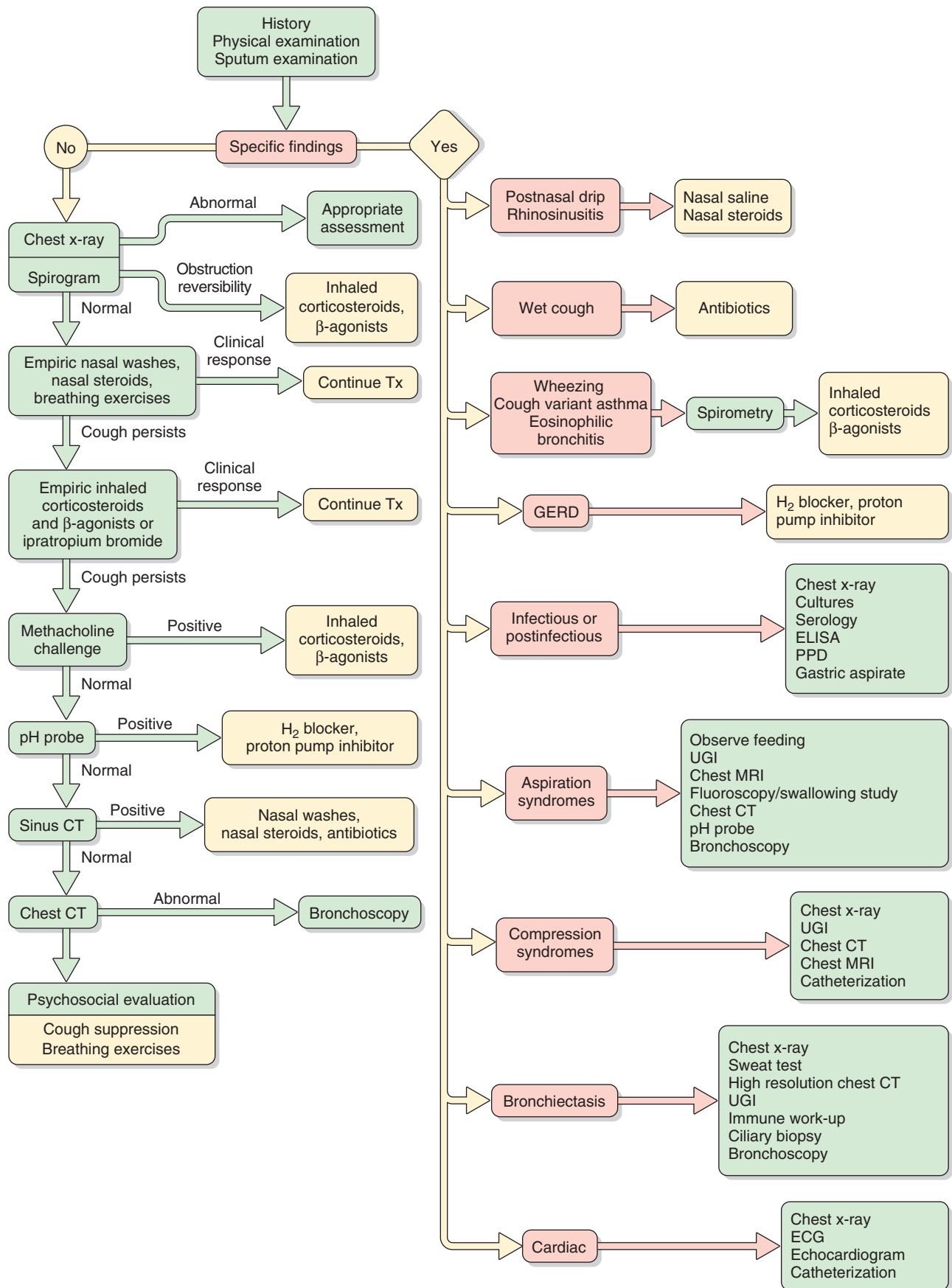

**Figure 27-1** Algorithm for the evaluation and treatment of chronic cough in childhood. CT – computed tomography, Tx – therapy, GERD – gastroesophageal reflux disease, ELISA – enzyme-linked immunosorbent assay, PPD – purified protein derivative, UGI – upper gastrointestinal series, MRI – magnetic resonance imaging, ECG – electrocardiogram.

**BOX 27-1 DIFFERENTIAL DIAGNOSIS OF CHRONIC COUGH**

## Congenital anomalies

- Connection of the airway to the esophagus
  - Laryngeal cleft
  - Tracheoesophageal fistula
- Laryngotracheomalacia
  - Primary laryngotracheomalacia
  - Laryngotracheomalacia secondary to vascular or other compression
- Bronchopulmonary foregut malformation
- Congenital mediastinal tumors
- Congenital heart disease with pulmonary congestion
- Chiari type I malformation
- Infectious or postinfectious cough
  - Recurrent viral infection (infants and toddlers)
  - Chlamydial infection (infants)
  - Whooping cough-like syndrome
    - Bordetella pertussis* infection
    - Chlamydia* infection
    - Mycoplasma* infection
  - Cystic fibrosis (infants and toddlers)
- Granulomatous infection
  - Mycobacterial infection
  - Fungal infection
- Suppurative lung disease (bronchiectasis and lung abscess)
  - Cystic fibrosis
  - Foreign body aspiration with secondary suppuration
  - Ciliary dysfunction
  - Immunodeficiency
    - Primary immunodeficiency
    - Secondary immunodeficiency (acquired immune deficiency syndrome)

- Paranasal sinus infection
- Cough-variant asthma
- Rhinitis related
  - Allergic rhinitis
  - Rhinosinusitis
  - Vasomotor rhinitis
  - Postnasal drip
- Gastroesophageal reflux without aspiration
- Vocal cord dysfunction
- Aspiration (fluid material)
  - Dyskinetic swallowing with aspiration
  - General neurodevelopmental problems
  - Möbius' syndrome
  - Chiari malformations
- Bottle-propping and bottle in bed (infant and toddlers)
- Gastroesophageal reflux
- Foreign body aspiration (solid material)
  - Upper airway aspiration (tonsillar, pharyngeal, laryngeal)
  - Tracheobronchial aspiration
  - Esophageal foreign body with an obstruction or aspiration resulting from dysphagia
- Physical and chemical irritation
  - Smoke from tobacco products (active and passive)
  - Wood smoke from stoves and fireplaces
  - Dry, dusty environment (hobbies and employment)
  - Volatile chemicals (hobbies and employment)
  - Dampness
  - Mold
- Psychogenic cough
- Habit cough

Modified from Brown MA, Morgan WJ. *Clinical assessment and diagnostic approach to common problems*. In: Taussig LM, Landau LI, editors. *Pediatric respiratory medicine*. St Louis: Mosby; 1999.

Unfortunately, most studies rely on parents to give an account of their child's cough, a method that has been shown to provide inaccurate information.<sup>16,17</sup> When questionnaires administered to parents about their child's coughing were compared to overnight recordings performed in 145 homes, the agreement was low.<sup>18</sup>

## Pathophysiology

(Figures 27-2 and 27-3)

Cough serves as a protective mechanism to clear the respiratory tract and to defend it against the aspiration of noxious materials. While mechanical barriers limit the exposure of the respiratory tract to inhaled pathogens, the mucociliary apparatus and cough act to expel any organisms that may have bypassed the primary defenses. Two associated processes, bronchoconstriction and mucus secretion, add to its effectiveness. Recurrent partial collapse or incomplete inflation of the lungs and pneumonia associated with ineffective cough attest to its importance.<sup>19</sup>

Cough is executed as a complex reflex, an automatic or involuntary response to a stimulus, completed by the afferent and efferent pathways and a putative cough center in the brain, but also, at least in part, intensified or restrained under voluntary control. The main afferent pathways of cough originate in nerve receptors immediately beneath the respiratory epithelium in the larynx and the tracheobronchial tree, and in extrapulmonary

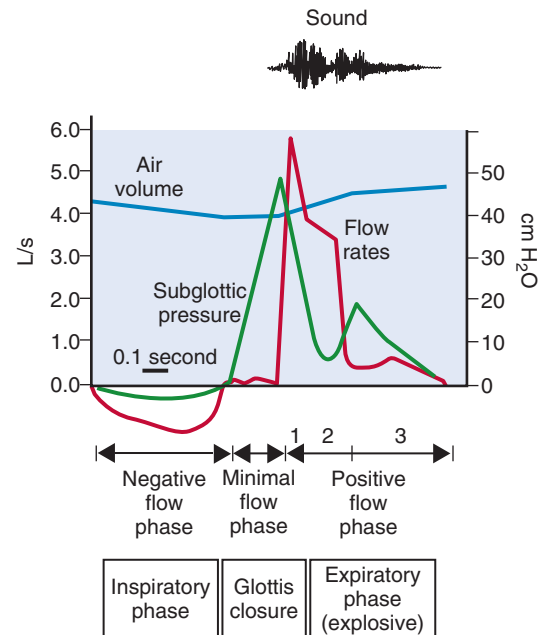

**Figure 27-2** Changes in flow rate, air volume, subglottic pressure and sound level generated during the act of coughing. (From Bianco S, Robuschi M. *Mechanics of cough*. In: Braga PC, Allegra L, editors. *Cough*. New York: Raven; 1989.)

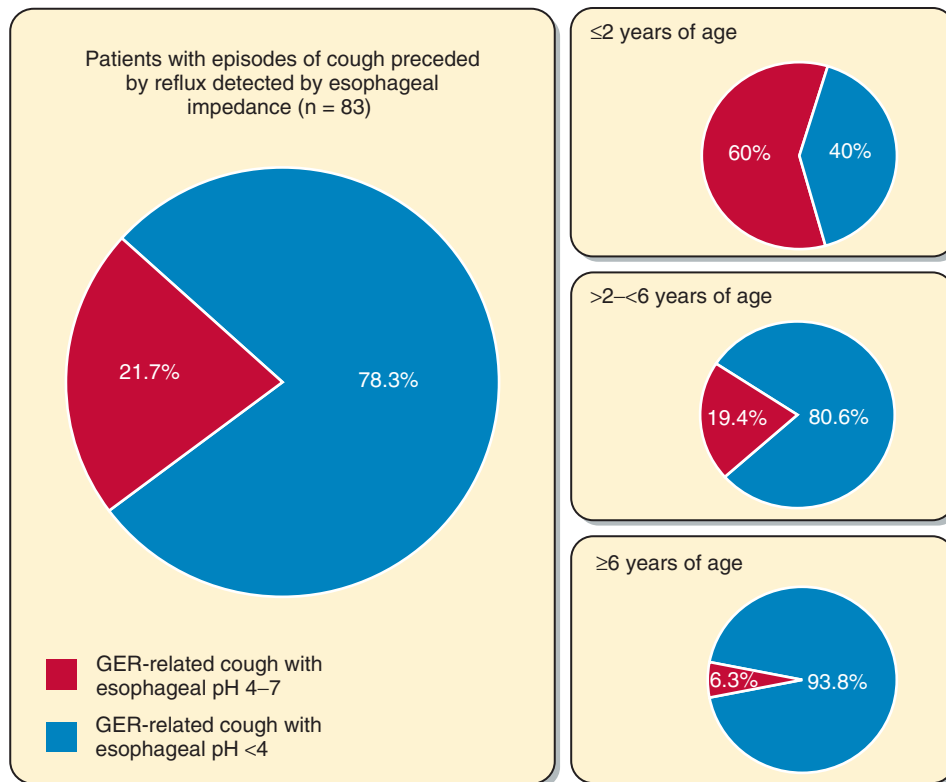

**Figure 27-3** Proportion of children with cough preceded by reflux with pH 4-7 or <4, n = 83. The three small panels on the right present the data by age: <2 years (n = 15), >2-6 years (n = 36), ≥6 years (n = 32). (From: Ghezzi M, Guida E, Ullmann N, Sacco O, Mattioli G, Jasonni V, Rossi GA, Silvestri M. Weakly acidic gastroesophageal refluxes are frequently triggers in young children with chronic cough. *Pediatr Pulmonol* 2013;48:295-302).

sites: the nose, the paranasal sinuses, the pharynx, ear canals and ear drums, the pleura, the stomach, the pericardium and the diaphragm. Nerve impulses from the tracheobronchial tree pass through the vagus, the principal afferent pathway. Cough may result from direct stimulation of this nerve.<sup>20</sup> The trigeminal, glossopharyngeal and phrenic nerves conduct impulses from extrapulmonary sites.<sup>21</sup> Axon reflexes traveling through branches of sensory end-organs may cause the release of neuropeptides and subsequent smooth muscle contraction, mucus secretion and epithelial injury. Thus, sensory signals taking part in cough may trigger or enhance bronchospasm. Reflexes regulate the parasympathetic nervous system, and chronic cough lowers the threshold for sensory signals. Efferent impulses of the cough reflex are transmitted to the respiratory musculature through the phrenic and other spinal motor nerves, and to the larynx through the recurrent laryngeal branches of the vagus. The vagus also provides efferent innervation to the tracheobronchial tree where its branches mediate bronchoconstriction.

## Cough and Bronchospasm

Cough and bronchospasm are two closely related reflexes that enhance one another, but neither depends on the other for its action.<sup>22</sup> Cough clears the airways effectively only at high lung volumes; sufficient air velocity to shear mucus from bronchial walls can be achieved only down to the sixth or seventh generation of airway branching.<sup>23</sup> Co-existing bronchoconstriction adds to the effectiveness of cough by extending peripherally the region of rapid and turbulent airflow. Challenge with either

methacholine or histamine provokes both cough and bronchoconstriction.<sup>24</sup> However, the receptors for both reflexes are functionally distinct, and either response can arise independently. Challenge with hyperosmolar solutions causes both cough and bronchoconstriction, but hypo-osmolar solutions tend to bring about cough alone.<sup>25</sup> Pretreatment divides induced cough from bronchoconstriction.<sup>26</sup> When aerosolized water serves as the provoking agent, inhaled lidocaine blocks cough but not bronchoconstriction. When inhaled capsaicin is used to provoke cough, opiates administered systemically suppress cough whereas those administered by inhalation suppress bronchoconstriction.<sup>26</sup> Bronchoconstriction, but not the urge to cough, can be blocked by pretreatment with intravenous atropine, consistent with the role of cholinergic pathways in the efferent limb of reflex bronchoconstriction. The mechanisms that trigger cough and bronchospasm following exercise or exposure to cold air appear to be different. Cough results mainly from excessive water loss, while bronchoconstriction follows airway rewarming.<sup>27</sup> Cold, air-induced bronchoconstriction can be blocked by  $\beta$ -adrenergic agents, but cough cannot. Cough most often results from excitation of receptors concentrated in the larynx and proximal airways, while bronchoconstriction can be triggered from the lower airways as well. Finally, inflammatory changes in the airways may result in cough without simultaneously giving rise to bronchospasm.<sup>28</sup>

## Cough-Variant Asthma

Childhood asthma is a syndrome of inflammation in medium and small airways that gives rise to hyperresponsiveness and



constriction of the bronchial smooth muscle, edema and disruption of the mucosa, and obstruction of the airway lumen.<sup>29</sup> Inflammation may lead to airway remodeling with proliferation of smooth muscle and deposition of matrix proteins. Cough-variant asthma is associated with the same disordered physiological processes and presenting signs, but overt wheezing is absent, and cough is the most discernible clinical sign. However, substantial evidence shows that awareness of symptoms by children with asthma is poor,<sup>30</sup> and both children and their parents may be more aware of cough than of other symptoms that may be present as well.

The diagnosis of asthma on the basis of cough alone accounts for the profusion of cases of cough-variant asthma that are open to doubt.<sup>31</sup> In 1991, 10% of children with cough as the only symptom were diagnosed as having asthma; 2 years later, the figure had increased to 22.6%. Whereas in the past, cough may have been underrecognized as a sign of asthma, at present the opposite appears to be true.<sup>32,33</sup> This is borne out by reports in which children with persistent nocturnal cough improved after 2 weeks of placebo therapy and received only modest additional benefit from a course of high-dose inhaled corticosteroids.<sup>34</sup> Inhaled albuterol and beclomethasone in children with cough, but without wheezing, were no more effective than placebo in reducing cough frequency.<sup>35</sup> Surprisingly, even the documentation of airway hyperreactivity did not predict a child's response to these asthma medications. A study of nocturnal cough showed that in the absence of wheeze, shortness of breath or tightness of the chest, cough did not indicate hidden or atypical asthma in most children.<sup>36</sup> Children under 4 years of age with frequent recurrent wheeze and a stringent index for the prediction of asthma at school age showed significantly higher median fractional exhaled nitric oxide (NO) levels (11.7 [11.85]) (median [interquartile range]) than children with recurrent cough but no history of wheeze (6.5 [5.5];  $P < .001$ ) and those with early recurrent wheeze and a loose index for the prediction of asthma at school age (6.4 [6.5];  $P < .001$ ). No difference in FeNO levels was found between children in the latter two groups ( $P = .91$ ).<sup>37</sup> A prospective study of infants followed up to age 11 years, showed that recurrent cough present early in life resolved in the majority of children. Children with recurrent cough but without wheeze did not have airway hyperresponsiveness or atopy, and significantly differed from those with classical asthma, with or without cough.<sup>38</sup> Brooke and colleagues reassessed, during the early school years, a cohort of children identified as having recurrent cough in the preschool period. Seventy of 125 (56.0%; 95% CI 47.3–64.5%) were symptom-free at follow-up, 46 (36.8%; 95% CI 28.7–45.5%) continued to have recurrent cough in the absence of colds, and only nine (7.2%; 95% CI 3.6–12.8%) reported recent wheezing. The authors concluded that long-term recurrent cough in some children is consistent with the diagnosis of cough-variant asthma, but that few progress to develop asthma characterized by wheeze.<sup>39</sup>

Isolated cough is rarely due to asthma and often fails to respond to asthma medications.<sup>40</sup> On the other hand, patients with a prolonged history of cough who respond to treatment with asthma medications or show evidence of bronchospasm or hyperresponsiveness without concurrent wheezing may be considered to have cough-variant asthma. Patients may be free of bronchoconstriction at the time of their evaluation. Their history of respiratory disease may be difficult to assess, while physical findings and routine pulmonary function tests may disclose no evidence of airway obstruction. In such cases,

evaluation of airway function by bronchial provocation with methacholine, histamine or exercise is recommended. In children too young to perform pulmonary function testing, the diagnosis of cough-variant asthma may be confirmed by the patient developing unequivocal evidence of reversible airways obstruction later in the clinical course and by the patient's response to asthma therapy.

## Cough During and After Respiratory Infection

Children have an average of six to eight respiratory infections per year, a number that may be higher in those with siblings or in daycare. Repeated infections common in winter months may result in a chronic cough. Acute bronchitis usually follows the symptoms of upper respiratory illness. Cough associated with infection with respiratory syncytial virus (RSV), other respiratory viruses and cytomegalovirus, *Mycoplasma pneumoniae*, *Chlamydia trachomatis*, *Ureoplasma urealyticum*, *Pneumocystis jiroveci* (formerly *carinii*), *Corynebacterium diphtheriae* and *Bordetella pertussis* often lasts beyond the acute stage. Measles causes a cough with coryza, conjunctivitis and fever. In the immunized patient, atypical measles is more likely to cause cough or pneumonia than the characteristic rash.

Persistent bacterial bronchitis (PBB) is an increasingly diagnosed form of chronic wet cough that occurs in children with a history of mild asthma or possibly misdiagnosed asthma.<sup>41</sup> Some of the children have a history of invasive medical therapy (prolonged ventilation, cardiac surgery) and many have an underprivileged background. These children have a chronic wet productive cough with bacteria such as *Streptococcus pneumoniae*, *Haemophilus influenzae* and *Moraxella catarrhalis* persisting in the airways, and an associated neutrophilia. Spirometry and chest x-rays are typically normal. The cough responds to a course of antibiotic (e.g. amoxicillin-clavulanate for 2–4 weeks).<sup>42</sup> Prolonged duration of cough and increased neutrophil counts are related to worse high-resolution computed tomography scan scores. A recent retrospective study identified a cohort of children with protracted bacterial bronchitis that for the most part had started in infancy.<sup>43</sup> Almost three quarters of the children had an associated airway malacia. These children responded well to antibiotics, although a significant number relapsed and needed additional courses of treatment.<sup>43</sup> A favorable response to a course of antibiotics confirms the diagnosis of PBB and further investigations may be unnecessary. Children who do not respond to treatment require investigation for specific causes of suppurative lung disease. This includes a sweat test and genotyping for cystic fibrosis, exhaled NO, evaluation of ciliary ultrastructure and beat frequency, white cell count, immunoglobulin levels and functional antibody studies, barium swallow, swallowing videofluoroscopy and esophageal reflux studies.<sup>41</sup>

The pathogenesis of postinfectious cough is not known. Children with persistent postinfectious cough do not have airway eosinophilia typical of untreated asthma, but some manifest increased reactivity of the airways. These observations suggest that postinfectious cough has different pathophysiological features from asthma.<sup>44</sup> The infection causing the cough, in most cases, remains unidentified. The diagnosis is clinical and one of exclusion. It should be considered in patients with normal chest x-rays and pulmonary function tests who cough only after respiratory tract infections. Postinfectious cough generally regresses over time, but it often recurs. Its resolution may

be accelerated by the administration of inhaled corticosteroids or ipratropium bromide.<sup>45</sup>

### ACUTE VIRAL BRONCHIOLITIS

Bronchiolitis occurs in epidemics during the winter months in temperate regions, and during the hottest months and the rainy season in tropical climates. Cough set off by microorganisms contributes to their spread and survival. RSV is the leading cause of epidemic bronchiolitis, accounting for over 40% of cases. Influenza, parainfluenza type 3 and adenovirus are responsible for many of the remaining cases. The human metapneumovirus and bocavirus also play a significant role.<sup>46</sup> The risk of RSV illness in the first year of life is over 60%, and it will have infected nearly all children by the age of 2 years.<sup>47</sup> RSV lower respiratory tract infections lead to 125,000 hospital admissions per year in the USA. Eighty percent occur in infants with a peak incidence at 2 to 8 months.<sup>48</sup> RSV accounts for 25% of all acute hospitalizations in children younger than 5 years with chronic lung disease. Between 0.5% and 3.2% of children with RSV infection require hospitalization, and there are approximately 4500 deaths per year. Environmental risk factors for severe RSV infection include poverty, crowding, exposure to tobacco smoke and malnutrition. Older children and adults develop antibodies to RSV, but the immunity is incomplete, and re-infection may occur at any age. In these older patients, infection with RSV usually takes the form of an upper respiratory illness, often with bronchitis.

There is a general consensus that following even mild RSV bronchiolitis, children are at increased risk for repeated bouts of respiratory symptoms during the first 3 years of life.<sup>49</sup> Stein and colleagues reported a relationship between RSV infection and recurrent respiratory symptoms up to 6 years of age, but not to asthma after the age of 13 years.<sup>50</sup> However, more recent evidence points to an association between severe RSV infection early in life and increased incidence of asthma and eczema later.<sup>51</sup> Further, hospitalization for bronchiolitis in infancy is associated with an increased risk of asthma, and an increased use of asthma medication at 28 to 31 years of age.<sup>52</sup>

### MYCOPLASMA PNEUMONIAE

Most *Mycoplasma pneumoniae* infections in infants and young children are asymptomatic or are associated with upper respiratory symptoms only.<sup>53</sup> However, it is the most frequent cause of pneumonia in children between 5 and 15 years of age,<sup>54</sup> and a cause of bronchiolitis in all age groups. *Mycoplasma pneumoniae* pneumonia presents with a gradual onset of malaise, fever and headache. Cough begins several days after the onset of the illness and often persists for weeks. It may be productive of white or blood-tinged sputum. Physical findings include crackles, rhonchi and bronchial breath sounds. The incidence of wheezing with the acute infection has been reported to be 40%. X-ray findings, though not diagnostic, frequently show unilateral lower lobe involvement. The pattern is initially reticular and interstitial. Later, patchy segmental consolidation is seen. Hilar adenopathy and pleural effusions may be present. Ten percent of the children develop an exanthem and 36% have elevated hepatic transaminases. The diagnosis can be made by measuring specific IgM antibody. A rise in IgG antibody takes between 1 and 2 weeks post infection. Cold agglutinins are positive in about 40% to 60% of patients; however, the results are not specific. There is little evidence that treatment with antibiotics is helpful during the acute

illness; however, macrolide antibiotics may shorten the duration of fever and respiratory symptoms.

Infection with mycoplasma may produce a long-term impairment in lung function even in asymptomatic children. Clinical reports, throat culture and serological studies, and animal models suggest a role for mycoplasma in airway hyper-responsiveness. In nonasthmatic subjects, significant response to bronchodilators has been noted 1 month after infection. More significantly, abnormal forced expiratory volume in 1 second (FEV<sub>1</sub>) and forced expiratory flow after 50% of the expired vital capacity have been noted up to as long as 3 years after initial infection.<sup>55</sup>

### BORDETELLA PERTUSSIS (see Box 27-2)

Before widespread vaccine coverage started in the late 1940s, there were as many as 270,000 cases of pertussis diagnosed in the USA per year, with as many as 10,000 deaths, predominantly among infants. Pertussis reached epidemic proportions every 2 to 5 years. Immunization with diphtheria–tetanus–pertussis (DTP) using whole *Bordetella pertussis* reduced the average incidence of pertussis in the USA from 157 per 100,000 population in the early 1940s to fewer than one in 1973. However, the cycles of outbreaks continued because neither infection nor immunization produces lifelong immunity to pertussis.<sup>56</sup>

Because of concerns over the safety of the DPT vaccine, beginning in the early 1990s, the USA started the transition from DPT to diphtheria–tetanus–acellular pertussis (DTaP) for the immunization of children.

Pertussis is now resurgent, and many cases are occurring in vaccinated children and adolescents. In countries using acellular vaccines, waning immunity is at least part of the problem.<sup>57</sup> It appears that vaccination rates in the young population are satisfactory, but the same is not true for older individuals, including health workers.<sup>58–60</sup> In the years 2005–2010, the incidence of pertussis rose to between four and nine per 100,000.<sup>56</sup> A study was conducted from 2006 to 2011 to assess the risk of pertussis in children relative to the time elapsed after the fifth dose of DTaP. This period included a large outbreak in 2010. DTaP was being used for all five recommended doses. Year on year after the fifth dose of DTaP there was a 42% increase in odds of acquiring pertussis.<sup>61</sup>

As many as 90% of nonimmune household contacts acquire the disease. Infection in immunized children and older persons is often mild. The burden of disease assessed by rates of complications and death remains greatest in the youngest patients, but there has been a recent resurgence of less severe pertussis

#### BOX 27-2 RISK FROM DISEASE VS RISK FROM DTaP

##### PERTUSSIS

Pneumonia: 1 in 8  
Encephalitis: 1 in 20  
Death: 1 in 1500

##### DTaP

Continuous crying, then full recovery: 1 in 1000  
Convulsions or shock, then full recovery: 1 in 14,000  
Acute encephalopathy: 0–10.5 in 1,000,000  
Death: None proven

Source: <http://www.cdc.gov/vaccines/vac-gen/6mishome.htm#risk>

in adolescents and adults. These groups constitute a major source of disease transmission to younger children. Increased exposure to pertussis in the community, delay in identification and treatment, and high contact rates among children attending school or daycare contribute to the spread of the disease. It is important to note that pediatric healthcare workers are at particular risk for pertussis exposure, infection and subsequent disease transmission to susceptible patients.<sup>62</sup> In 2011, Tdap vaccination coverage among health workers was only 26.9%.<sup>58</sup>

The widespread use of whole-cell pertussis vaccine in combination with diphtheria and tetanus toxoids (DTP), starting in the USA in the late 1940s, led to a historic low point of 1010 cases of pertussis in 1976. However, since the early 1980s, cases of pertussis have increased with cyclical peaks every 3 to 4 years. In 1996, the US Centers for Disease Control and Prevention reported 7796 cases of pertussis, almost half of whom were aged 10 years or older. In the same year, acellular pertussis vaccines were licensed and recommended for routine immunization of infants.<sup>3</sup> The effectiveness of the complete vaccination series is 80% (95% CI 66–88%). Receiving fewer than three doses constitutes a significant risk factor (relative risk 5.1; 95% CI 3–8.6%).<sup>63</sup>

In the unvaccinated child, infection with *Bordetella pertussis* leads to a catarrhal phase lasting 1 to 2 weeks with rhinitis, conjunctivitis, low-grade fever and cough. *B. pertussis* infection causes infiltration of airway mucosa by lymphocytes and polymorphonuclear leukocytes, necrosis of the midzonal layers of the mucosa and injury to the ciliated epithelium of the respiratory tract. A stage of tracheobronchitis, lasting 1 to 6 weeks, ensues with episodes of paroxysmal cough that increase in number and severity. Repetitive forceful coughs during a single expiration are followed by an abrupt inspiration that produces the characteristic whoop. Many children experience post-tussive emesis. Fever is absent or minimal. Convalescence takes weeks to months. Pertussis is more severe in the first year of life. A clinical case is defined as an acute cough illness lasting a minimum of 14 days in a person with at least one pertussis-associated symptom (i.e. paroxysmal cough, post-tussive vomiting or inspiratory whoop) or 14 days of cough during an established outbreak. A confirmed case is a cough illness of any duration in a person from whom *B. pertussis* has been isolated, or that meets the clinical definition and is confirmed by polymerase chain reaction or an epidemiological connection to a laboratory-confirmed case.<sup>3</sup> Although *B. pertussis* infection should be suspected in children with paroxysmal cough, other organisms, most notably adenovirus, parainfluenza viruses, RSV and mycoplasma, have been implicated.<sup>40</sup>

There is growing evidence that *B. pertussis* is an important cause of persistent cough in adolescents and adults. Pertussis has been implicated in 16% of cases of chronic cough of adults in Denmark. Susceptibility to infection with *B. pertussis* recurs several years after vaccination. Moreover, cases of laboratory proven reinfection have been reported.<sup>64</sup> *B. pertussis* should be considered in patients with symptoms of typical or atypical whooping cough, irrespective of their vaccination status or past history of the disease.<sup>64</sup> By demonstrating *B. pertussis* in an adult, one can reassure him/her that the symptoms will subside without the need for extensive evaluation and treatment, and recommend measures to protect others, especially unvaccinated infants.<sup>65</sup> Droplet precautions are recommended for 5 days after initiation of effective therapy or until 3 weeks after the onset of paroxysms if appropriate antimicrobial therapy has

not been given. Erythromycin or clarithromycin eliminates pertussis from the nasopharynx in 3 to 4 days, decreasing the spread of the disease.<sup>66</sup> Given within 14 days of onset, these antibiotics may abort pertussis. Once paroxysms of cough develop, antibiotics have little effect on the course of illness. An association between erythromycin and idiopathic hypertrophic pyloric stenosis has been reported in infants.<sup>67</sup> There are no such reports for clarithromycin.<sup>68</sup>

In addition to maintaining high vaccination rates among preschool children, effort must be directed at the identification and treatment of pertussis cases to prevent further spread of the disease. Erythromycin (40–50 mg/kg per day orally in four divided doses, maximum 2 g/day) for 14 days is recommended for all close contacts irrespective of age or immunization status. Exposure of infants to children and adults with cough illnesses should be minimized.

A major public health challenge at present is to address the illness in adolescents and adults. A rational strategy might be a universal booster vaccination for adolescents and a program targeted at those adults most likely to have contact with infants.

### CHLAMYDIA TRACHOMATIS

Infants with *C. trachomatis* infection present with a high-pitched, staccato, nonproductive cough and tachypnea without fever that begins around 4 weeks of age and lasts for several weeks, even after therapy with erythromycin.<sup>69</sup> Concomitant conjunctivitis is a frequent finding.

### MYCOBACTERIUM TUBERCULOSIS

Pediatric pulmonary tuberculosis remains a major cause of morbidity and mortality worldwide.<sup>70</sup> From 1985 to 1992, the number of cases of childhood tuberculosis (TB) increased; however, between 1992 and 1998, the numbers declined substantially in all age groups. The incidence of TB among children is lower than among adults, and most of the pediatric morbidity and mortality occur in children younger than 5 years of age. In the USA, the groups with the highest rates include immigrants from Asia, Africa and Latin America, the homeless and residents of correctional facilities.<sup>71</sup>

Children contract TB from adults and adolescents; disease transmission among youngsters is most uncommon. When the tuberculin skin test converts to positive, most *M. tuberculosis* infections in children are asymptomatic. The radiographs at that time are usually negative, and the primary infection progresses slowly. Infection with *M. tuberculosis* that becomes symptomatic usually involves the hilar and mediastinal lymph nodes as well as lung parenchyma. Early manifestations become evident 1 to 6 months after initial infection. They include fever, weight loss, cough, night sweats and chills. Chest x-rays may show lymphadenopathy of the hilar and mediastinal nodes, involvement of a lung segment or lobe with atelectasis or infiltrate, cavitory lesions and miliary disease. Tuberculous meningitis may be an early finding. Later extrapulmonary manifestations may involve the middle ear, mastoid, bones, joints, skin, and kidneys.<sup>71</sup>

The recommended treatment regimen for TB disease consists of an initial 2-month phase of four drugs: isoniazid, rifampin, pyrazinamide and ethambutol, followed by a 4-month continuation phase of isoniazid and rifampin. Ethambutol is generally not used for young children whose visual acuity



cannot be monitored. Streptomycin may be substituted for ethambutol, but must be given by injection. Ethambutol (or streptomycin) can be discontinued when drug susceptibility results show the infecting organism to be fully drug-susceptible.<sup>71</sup>

Children from Asia or Africa where tuberculosis is endemic may have cough, often with hemoptysis, and without fever, as a result of an infestation with a fluke of the genus *Paragonimus* acquired by eating undercooked freshwater crab or crawfish.

## Cough Associated with Allergic Rhinitis, Rhinosinusitis and/or Postnasal Drip

Allergic rhinitis and rhinosinusitis (both described elsewhere in this text) are associated with cough that results from postnasal drip and irritation of the larynx. Chronic sinusitis may be an early manifestation of immunodeficiency or ciliary dysfunction. Irwin and colleagues identified postnasal drip as the most common cause of chronic cough among their patients.<sup>5</sup> The diagnosis can be established by history. Mucoperiosteal changes on x-ray or sinus computed tomography (CT) of an atopic child in the absence of opacification or air-fluid levels and acute symptoms do not constitute an indication for treatment with antibiotics or sinus surgery. A most effective treatment is once or twice daily nasal irrigation with normal saline buffered by bicarbonate, followed by the instillation of a nasal corticosteroid spray.

## Cough Associated with Compression Syndromes

### TRACHEOBRONCHOMALACIA

Tracheo- or broncho-malacia is characterized by flaccidity or congenital absence of the cartilaginous rings supporting the trachea and/or the bronchi. Although most infants are asymptomatic, some present with cough, often described as brassy, paroxysmal dyspnea, wheezing and stridor.<sup>40</sup> Chest x-rays frequently show recurrent 'pneumonia' that results from the collapse of segments of the airway during expiration. Increased secretions associated with respiratory infections precipitate symptoms. The caliber of the airways on chest x-ray varies from normal to markedly reduced depending on the phase of respiration. The appearance of pneumonia is most often caused by atelectasis, but secondary infection of the collapsed lung may occur. Prolongation of the expiratory phase and suprasternal and intercostal retractions are common. The diagnosis is established by observation of the collapse of tracheal or bronchial walls on fluoroscopy or bronchoscopy. Intrinsic airway stenosis or extrinsic compression exaggerates the manifestation of tracheomalacia. These complications must be considered during endoscopy. If associated bronchospasm is present, it must be treated aggressively. Although the symptoms usually subside by 12 to 18 months of age, some infants may require a trial of continuous positive airway pressure or mechanical ventilation.

### VASCULAR RINGS

The trachea can become partially obstructed by a vascular abnormality involving a right aortic arch with left ligamentum

arteriosum or persistent ductus arteriosus, double aortic arch, anomalous innominate or left carotid artery. These abnormalities are generally referred to as vascular rings. Typical symptoms include inspiratory stridor, expiratory wheezing and a barking cough. Respiratory distress may be present, especially during feeding or when infection intervenes. Feeding difficulties may be present in the first few weeks of life. There may be recurrent pneumonia and atelectasis.

The presence of vascular rings must be considered in any infant with stridor. The chest x-ray may show a right or an indeterminate aortic arch. Tracheal compression by an anomalous innominate artery causes a curvilinear indentation of the anterior trachea. While barium esophagrams may show characteristic indentations from various anomalies of the aortic arch, magnetic resonance imaging (MRI) with its multiplanar images has become the imaging procedure of choice at many institutions. Laryngotracheobronchoscopy is useful in excluding upper airway obstruction. Tracheal compression viewed endoscopically may be recognizable as a pulsatile, extrinsic mass. Vascular rings may be life-threatening, but with prompt recognition and surgical treatment, they are usually completely correctable.<sup>11,72</sup>

### MEDIASTINAL MASSES

Mediastinal masses may be present at birth. Children under 2 years are likely to present with respiratory symptoms including dyspnea, cough, stridor and chest pain. Additional signs and symptoms may include cyanosis, atelectasis, superior vena cava syndrome, Horner's syndrome, dysphagia, spinal cord compression, intercostal nerve neuralgia, and cervical lymphadenopathy. These masses may be categorized as congenital or neoplastic. Most neoplastic tumors are malignant, and prompt diagnosis and treatment are required. In a large number of older children, the masses are asymptomatic and are recognized co-incidentally on chest x-rays. The asymptomatic masses are often benign. Chest x-rays provide information about location, size and presence or absence of calcifications. The barium swallow may be helpful in defining the anatomy. CT and MRI provide the most useful information for further diagnosis and treatment. Other helpful tests include percutaneous biopsy, bone marrow aspiration, urinary catecholamines and skeletal survey. Monoclonal antibodies have been used for diagnosis, assessment of response to therapy and monitoring for relapse.<sup>72</sup>

### BRONCHIAL STENOSIS

Bronchial stenosis is a fixed narrowing of the bronchus, usually not associated with other congenital malformations, although co-existing segmental bronchomalacia, most commonly of the left main bronchus, has been reported. In the past, tuberculosis was a common cause of bronchial stenosis. It can occur at any level along the bronchial tree, although it most commonly involves a main bronchus, just distal to the carina. The degree of stenosis is variable. Wheezing, both inspiratory and expiratory, is a typical presenting symptom. It may be associated with cough, dyspnea and stridor. Chest x-rays reveal recurrent atelectasis that may become secondarily infected. Hyperinflation is usually noted on the x-rays of patients with stenosis of the main bronchus. In patients with segmental bronchomalacia, the involved lung is usually hyperlucent. If the orifices of the upper lobes or right middle lobe are involved, there may be



an associated collapse. Recurrent consolidation or persistent collapse is a common radiological finding of stenosis of a lobar bronchus. Diagnosis is accomplished by endoscopy. Treatment varies with the severity of obstruction. In some cases, the administration of bronchodilators and chest physical therapy is sufficient; more severe cases may require positive pressure ventilation or surgery to remove the stenotic segment. Lobar resection may be necessary to control persistent infection.<sup>73</sup>

### TRACHEAL STENOSIS

Signs and symptoms of congenital tracheal stenosis include persistent cough and respiratory distress in the newborn period. Patients may have expiratory stridor and wheezing. History of feeding difficulties is common. Chest x-rays and fluoroscopy may reveal a missing segment of the trachea. Radiographs of the neck that are highly penetrated may show tracheal narrowing. In congenital tracheal stenosis there is intrinsic narrowing of the tracheal lumen caused by complete cartilaginous rings. The size of the lumen can be assessed by CT or MRI. The definitive diagnosis is made by endoscopy. The differential diagnosis includes extrinsic compression of the trachea by vascular rings or mediastinal masses. Tracheotomy may be necessary to maintain a patent airway. Endoscopic procedures can be used to treat thin tracheal webs and unilateral lesions. Conservative management of patients with mild symptoms should be attempted. Dilation of tracheal stenosis may provide a temporary solution until definitive surgical repair can be accomplished. Surgical treatment is associated with significant morbidity and mortality.<sup>73</sup>

### Cough Associated with Aspiration Syndromes

Aspiration pneumonia is a common disorder frequently mistaken for nonspecific respiratory infection, while aspiration bronchitis is often mistaken for asthma. In infants, these conditions are most commonly associated with the inhalation of milk as a result of one of three disorders: impairment of sucking or swallowing likely to be neurogenic in origin, GER or tracheoesophageal fistula. These are conditions that must not be overlooked.

The initial step in diagnosis is to observe the child, while nursing, for difficulty with sucking or swallowing or for associated cough or choking. Gross structural abnormalities of the mouth, jaw or palate can be noted. Placing a finger in the baby's mouth can assess the act of sucking. X-rays of children with aspiration bronchitis typically show perihilar thickening and increased bronchovascular markings, while those of children with aspiration pneumonia show patchy areas of uniform opacity that may have a segmental or lobar distribution. In infants, the posterior parts of the upper and lower lobes are most commonly involved, with the right side predominating. Fluoroscopy is used to evaluate the anatomy of the upper airway and esophagus and the swallowing function. Esophageal pH probe or impedance probe monitoring establishes the presence of reflux.<sup>74</sup> Bronchoscopy and microscopic examination for lipid-laden macrophages substantiate the diagnosis of aspiration.

Tracheoesophageal fistulas require prompt surgical repair. The management of a child with a swallowing disorder requires the assistance of a clinic that specializes in this problem.

### Gastroesophageal Reflux (see Figure 27-3)

GER is a common cause of chronic cough in individuals of all ages and of apnea in infants, even without co-existing aspiration. Its most likely mode of action is through vagal stimulation, although aspiration must be considered. GER has been documented in about half of adults with chronic cough, and it commonly occurs in children.<sup>75</sup> The respiratory manifestations of GER – cough, wheezing, sore throat, hoarseness, throat clearing, choking and throat irritation – often persist in the absence of more familiar symptoms such as heartburn and regurgitation.<sup>76</sup> Proton pump inhibitors or H<sub>2</sub> blockers effectively reduce the respiratory complications of GER. However, higher than standard doses may be necessary and therapy may need to be continued for several months before a therapeutic effect is achieved. Laparoscopic fundoplication has been performed safely, even in high-risk children.<sup>77</sup>

### Foreign Body

A foreign body may lodge in the hypopharynx, larynx, trachea, bronchus or esophagus. Aspiration of a foreign body into the airway typically causes stridor. It is a pediatric emergency requiring immediate management by a specialist, even though unsuspected bronchial foreign bodies may be present for a long time and lead to chronic bronchitis and bronchiectasis. Unrecognized esophageal foreign bodies resulting in tracheal compression have caused recurrent wheezing or cough without dysphagia for as long as a year. Cough, wheezing or dyspnea may date from the time of aspiration or may begin later, after edema and inflammation have set in and reflex bronchospasm has resulted. The majority of aspirated foreign bodies are foods such as peanuts or sunflower seeds, but a remarkable variety of objects has been removed at bronchoscopy. It is of note that peanuts release oils that irritate the bronchial mucosa, causing inflammation and edema. Other organic solids, such as beans, peas, corn or seeds, can absorb water and increase considerably in size.

In one third of patients with foreign body aspiration, the actual event goes unobserved by caregivers.<sup>78</sup> The diagnosis may be suspected on the basis of history and physical findings. Classical signs are wheezing, cough and decreased breath sounds. Use of a differential stethoscope may be helpful in detecting localized airway obstruction. The diagnosis is established by radiographic findings and ultimately by bronchoscopy. Chest x-rays show atelectasis in cases of complete obstruction of a bronchus. In cases of partial obstruction, the foreign body may act as a valve that allows air entry but impedes exhalation from a portion of a lung. Comparison of inspiratory and expiratory radiographs shows a hyperinflated obstructed portion in comparison to the unaffected lung following expiration. On decubitus radiographs and fluoroscopy, the dependent lung should show less inflation unless obstructive hyperinflation from the valve-like mechanism is present. Bronchoscopy provides decisive evidence for diagnosis and treatment. Rigid bronchoscopy is preferred because it allows for the removal of the foreign body at the time of diagnosis. Treatment with bronchodilators, postural drainage and chest physical therapy as an alternative to bronchoscopic removal of the foreign body is no longer recommended.

## Cystic Fibrosis

Cystic fibrosis is diagnosed with increasing frequency during neonatal screening. The presenting symptoms of this disease are cough, poor weight gain and abnormal stools. The earliest symptom is usually a loose cough. Most patients experience recurrent lower respiratory infection before 12 months of age, but the age of onset is variable. Purulent bronchitis may be associated with wheezing and cough, and the diagnosis of asthma is often made in error. Purulent chronic cough in children must always be regarded as a pathological finding.<sup>40</sup>

## Allergic Bronchopulmonary Aspergillosis

Timely diagnosis of allergic bronchopulmonary aspergillosis (ABPA) is important because untreated ABPA results in progressive, irreversible lung damage. ABPA is a disease differentiated by recurrent infiltrates on chest x-ray, markedly elevated serum immunoglobulin E (IgE), eosinophilia and underlying asthma. Clinically it is characterized by afebrile episodes of cough, sputum production, dyspnea and wheezing.

## Hypersensitivity Lung Disease

Hypersensitivity pneumonitis or extrinsic allergic alveolitis is a syndrome that results from sensitization to inhaled organic dusts, which in children are most often avian antigens. Bird fancier's disease has been reported to occur in families. During acute attacks, patients suffer from both respiratory and systemic symptoms, including cough, dyspnea, temperature as high as 40°C, chills and myalgia.

## Vocal Cord Dysfunction

Vocal cord dysfunction (VCD) is a condition characterized by a paradoxical adduction of the vocal cords on inspiration that causes shortness of breath, cough and stridor.<sup>79</sup> VCD in children commonly occurs during exertion and must be differentiated from exercise-induced bronchospasm (EIB). VCD has been documented in adolescents, usually female athletes.<sup>80</sup> Among these patients, perfectionism, depression and anxiety are common.

The chest x-rays in uncomplicated VCD are normal. Spirometry shows blunting or truncation of the inspiratory portion of the flow-volume curve. Because of the episodic nature of VCD, the flow rate patterns may vary, and during asymptomatic periods, normal flow-volume curves are likely to be found. It is possible to replicate symptoms and spirometric findings of VCD by exercise or inhalation challenge, but negative results do not rule out the diagnosis. Observation of the vocal cords of a patient experiencing either spontaneous or induced symptoms by flexible fiberoptic rhinolaryngoscopy documents the presence of VCD.<sup>79</sup> The examination can be videotaped or photographed for the medical records. Complications are rare and discomfort is minimal. In VCD, the vocal cords adduct anteriorly from the vocal process, and the posterior glottic chink remains open. The adduction occurs during inspiration or in both the inspiratory and expiratory phases. The adduction of vocal cords with an open glottic chink in a symptomatic patient unequivocally establishes the diagnosis of VCD.

In the author's experience, the most successful treatment of VCD is that derived from breathing exercises used for hyperfunctional voice disorders to decrease the laryngeal muscle tone. These techniques are likely to desensitize the cough pathways.<sup>79,81</sup> In some extreme cases, hypnosis, biofeedback and psychotherapy have been used successfully. An approach reserved for acute attacks is the administration of a mixture of helium and oxygen. More aggressive therapies under study for patients with intractable, recurrent symptoms include injection of botulinum toxin directly into one vocal cord or sectioning of the laryngeal nerve.<sup>79,81</sup>

## Psychogenic Cough

Although it has been suggested that psychogenic cough typically ceases at night and has a barking or honking character, in actual fact, there are no distinguishing clinical features, and the diagnosis should be considered only after other possibilities have been excluded.<sup>45</sup> In some cases, a complete evaluation may require an assessment of the psychosocial factors that influence the origin, progression, persistence and/or exacerbation of chronic cough. Some children derive secondary gain in the form of greater attention or emotional support from their parents. In others, trauma such as physical abuse or school phobia may cause a conversion syndrome. A psychological evaluation may be necessary to focus on specific detrimental effects of the cough, a disruptive process that may affect negatively a broad spectrum of social and interpersonal experiences. This may range from distress at school to exclusion from play, social functions or participation in sports. As in other chronic medical conditions, emotional responses to the symptom may need to be addressed. Depression and frustration are the most common adjustment reactions, but negative responses may range over the entire affective spectrum.

Patients with psychogenic cough often believe that they have a serious chest problem. The diagnosis has been made in 3% to 10% of children with cough of unknown etiology that persists for more than 1 month. In 17 published reports, 149 of 153 patients were under 18 years of age. While wholly psychogenic cough is rare, children and/or parents may exaggerate some or all aspects of the cough. Occasionally it is difficult to reconcile the parents' or child's accounts with clinical findings. The parents may demand inappropriate treatment and may instill in the child the belief that he/she is physically disabled. When clinical findings differ from the history, confirmation of the cough by the use of a recording device and/or admission to the hospital for observation may be invaluable. The circumstances call for sympathy and understanding, and the doctor's responsibility to the child must take precedence over the doctor-parent relationship.

Habit cough, a diagnosis of exclusion, results from the lowering of the threshold for sensory signals in chronic nonproductive cough that may become self-perpetuating and persist even after the initial inciting reason is no longer present.

## Evaluation

Information about the history of onset, character of the cough (harsh, dry, productive, paroxysmal), triggers, time of occurrence and accompanying symptoms or sensations may offer clues about its etiology. A detailed health history must be obtained with attention to the neonatal period; feeding

problems; congenital malformations affecting the heart, great vessels, nasopharynx and upper respiratory tract, and gastrointestinal tract; respiratory infections; signs and symptoms of chronic illness; respiratory symptoms including those relating to the upper airway, such as postnasal drip or irritation, and lower respiratory tract, such as wheezing, dyspnea and exercise tolerance; heartburn; nocturnal symptoms; and environmental exposures, including cigarette smoke, at home, at school, at daycare, and at the homes of close playmates. The social history provides information about family or school problems that may contribute to psychogenic cough.

The physical examination focuses on the head and neck and the respiratory and cardiovascular systems. Signs of allergic rhinitis, stridor, tachypnea, hyperinflation, wheezes, crackles, rhonchi (with special attention paid to unilateral or asymmetric findings), heart murmurs, gallops and congestive heart failure are sought.

Eosinophils on the nasal smear suggest allergic rhinitis and neutrophils infectious sinusitis. Eosinophils in the sputum suggest asthma. Pulmonary function testing should be undertaken in any child capable of performing the necessary maneuvers. Generally, useful data include a complete blood count with differential, serum IgE, allergy skin tests, an examination of the vocal cords, chest and sinus x-rays and/or CT, bronchial challenge, and esophageal pH or impedance monitoring.<sup>82</sup> Exhaled NO may help to identify toddlers with recurrent cough who will go on to develop asthma. Other laboratory tests based on clinical findings comprise specific studies recommended for the conditions discussed above. They include sputum culture, immunoglobulins, purified protein derivative (PPD), sweat test and ciliary biopsy. Bronchoscopy is rarely indicated. For dynamic evaluation of compression syndromes, flexible bronchoscopy provides the best detail, but if a foreign body aspiration is likely, rigid bronchoscopy should be used. Cough with hemoptysis is an indication for a chest x-ray, chest CT and bronchoscopy.

## Environment

It is important to obtain an environmental history of children with chronic cough because it may be possible to improve their surroundings. Environmental history for chronic cough should include exposure to cigarette smoke in all children, to aeroallergens, especially indoors, in older children, and dietary history in infants and toddlers. In utero exposure to mainstream smoke from the mother and even to environmental tobacco smoke changes fetal lung development and causes airflow obstruction and airway hyperresponsiveness. Children exposed to environmental tobacco smoke postnatally have more symptoms of cough, wheeze, respiratory illnesses, decreases in lung function and increases in airway responsiveness.<sup>83</sup> A survey of respiratory symptoms in children aged 12 to 14 years was conducted throughout Great Britain as part of the International Study of Asthma and Allergies in Childhood (ISAAC). The response rate was 79.3%, and 25,393 children in 93 schools participated.<sup>84</sup> Cough and phlegm were associated with active and passive smoking. Gas cooking was significantly associated with dry night cough. The prevalence of cough and phlegm tended to be higher in metropolitan areas; the opposite applied to asthma. Exposure to any passive smoking raised the odds ratio (OR) for night cough (OR = 1.8), snoring (OR = 1.4) and respiratory infections during the first 2 years of life (OR = 1.3). Respiratory

problems were more prevalent in homes with reported molds or dampness with adjusted OR ranging from 1.32 (95% CI 1.06–1.39) for bronchitis to 1.89 (95% CI 1.58–2.26) for cough.<sup>85</sup> There is an association between coal fires and nocturnal cough.<sup>86</sup>

## Treatment

The goal of clinical evaluation of chronic cough is to identify its causes and to prescribe specific remedies such as modification of the child's environment and treatment of postnasal drip or GER. Antiasthma drugs are not reliably effective in patients with chronic dry cough, nevertheless a 2- to 4-week course of a potent inhaled corticosteroid should be administered to children with prolonged cough without wheeze who have not already received such therapy, especially if they have obstructive pulmonary function tests or positive bronchial challenge results. Inhaled corticosteroids should be discontinued in children who have received an adequate trial and are continuing to cough, and whose pulmonary function tests are normal. Failure to improve after 4 weeks of inhaled corticosteroids and/or normal pulmonary function tests calls for consideration of alternative diagnoses and for proceeding with the clinical evaluation described above. New treatment should be directed at all conditions identified as potentially responsible for the patient's cough and should include breathing exercises.<sup>79</sup>

Health information available on the Internet relating to treatment of cough is generally unreliable. A review of websites identified more incorrect than correct information, and only one of 19 received a high score.<sup>87</sup> Parents may hold unrealistic expectations and may demand needless medications. In such cases, it is best to acknowledge the child's discomfort, to give a realistic time course for resolution of symptoms and to promote active management with non-pharmacological treatments. Patient education fulfills an important role in the management of chronic cough. The patient and family who understand how individual mechanisms contribute to the cough and where each type of treatment fits, carry out their regimen with greater adherence and reduced anxiety. They cope more effectively with the symptoms, especially during periods of exacerbation. On rare occasions, it may be necessary to enlist the help of a psychotherapist to help the family accept the diagnosis and to adhere to therapy.

Over-the-counter pediatric cough and cold medications are widely marketed and used despite lack of evidence of efficacy and numerous recent reports challenging their safety. Serious adverse effects have been associated with accidental overdose, inadvertent misuse and drug-drug or drug-host interactions in children given standard doses.<sup>88</sup> An estimated 7091 children under 12 years are treated annually in the USA in emergency departments for adverse drug events attributable to cough and cold medications. Most visits (64%) are for children aged 2 to 5 years. Unsupervised ingestions account for 66% of estimated emergency department visits.<sup>89</sup> Data obtained from 4267 children enrolled from 1999 to 2006 in the Slone Survey, a random digit-dial telephone survey of medication use by the US population, disclosed that in a given week, 10.1% of US children use a cough and cold medication. Exposure is highest to decongestants (6.3%; mostly pseudoephedrine) and first-generation antihistamines (6.3%; the most common were chlorpheniramine, diphenhydramine and brompheniramine), followed by antitussives (4.1%; mostly dextromethorphan) and expectorants (1.5%; almost exclusively guaifenesin). Multiple-ingredient

## BOX 27-3 KEY FEATURES

## EVALUATION OF CHRONIC COUGH

- Cough is a common manifestation of disease in childhood.
- Cough is an important defense mechanism.
- Cough functions as a complex neurological reflex.
- Cough may be classified as acute (lasting <3 weeks), subacute (lasting 3–8 weeks) or chronic (lasting >8 weeks).
- Persistent bacterial bronchitis (PBB) is characterized by a chronic wet productive cough, with bacteria such as *Streptococcus pneumoniae*, *Haemophilus influenzae* and *Moraxella catarrhalis* persisting in the airways and an associated neutrophilia. Spirometry and chest x-rays are typically normal. The cough typically responds to a course of antibiotics (e.g. amoxicillin-clavulanate for 2–4 weeks).<sup>42</sup>
- The cause of chronic cough can be determined in most patients; specific therapy based on a systematic evaluation is usually successful.
- A chest radiograph should be obtained in children with chronic cough to rule out lower respiratory tract and cardiac pathology.
- Postnasal drip, acting alone or with other conditions, is the most common cause of chronic cough.
- Asthma is very often associated with chronic cough, but few children with chronic cough develop asthma.
- Cough-variant asthma is suggested by (1) airway obstruction and reversibility, (2) airway hyperresponsiveness and/or (3) clinical improvement after treatment with asthma medications.
- Gastroesophageal reflux may cause or intensify chronic cough through a vagal reflex or as a result of aspiration of stomach contents.
- Postinfectious cough resolves over time; the use of oral or inhaled corticosteroids or ipratropium bromide may shorten its duration.
- Congenital anomalies and aspiration are relatively uncommon causes of chronic cough in children.
- Bronchiectasis is a rare cause of chronic cough in children.
- Psychogenic cough and habit cough are diagnoses of exclusion.

products accounted for 64.2% of all cough and cold medications used. Exposure to antitussives, decongestants and first-generation antihistamines was highest among 2- to 5-year olds (7.0%, 9.9% and 10.1%, respectively) followed by children younger than 2 years (5.9%, 9.4% and 7.6%, respectively).<sup>90</sup> During 2004 to 2005, an estimated 1519 children under 2 years of age were treated in US emergency departments for adverse events associated with cough and cold medications. A review by the Food and Drug Administration (FDA) covering several decades identified 123 deaths related to the use of such products in children under 6 years of age.<sup>88,91</sup> The infants ranged in age from 17 days to 10 months. Postmortem testing showed evidence of recent administration of pseudoephedrine, antihistamine, dextromethorphan and/or other cold-medication ingredients.<sup>92</sup> On a positive note, pseudoephedrine use by children appears to be declining since the institution of the 2005 Combat Methamphetamine Epidemic Act.<sup>90</sup> In the Slone survey conducted from 1999 to 2006, use in 2006 (2.9%) was significantly lower than in 1999–2005 (5.2%).

## Conclusions

Our goals are not merely to find effective therapies for chronic cough, but also to identify and eliminate factors that predispose children to this aggravating problem. In the meantime we must strive to limit harm, such as children's exposure to tobacco smoke and families' reliance on over-the-counter medications. In addition to pertussis, outbreaks of *H. influenzae*, mumps and measles have been linked in the USA to vaccine avoidance. We should continue to reassure parents and to encourage them to vaccinate not only their children but also themselves. Every healthcare visit should be viewed as an opportunity to review the patient's immunization history and to ensure that everyone is fully vaccinated.

The key features of chronic cough are summarized in Box 27-3.

The complete reference list can be found on the companion Expert Consult website at <http://www.expertconsult.inkling.com>.

## KEY REFERENCES

- Chang AB, Robertson CF, Van Asperen PP, Glasgow NJ, Mellis CM, Masters IB, et al. A multicenter study on chronic cough in children: burden and etiologies based on a standardized management pathway. *Chest* 2012;142:943–50.
- Chang AB, Robertson CF, van Asperen PP, Glasgow NJ, Masters IB, Teoh L, et al. A cough algorithm for chronic cough in children: a multicenter, randomized controlled study. *Pediatrics* 2013;131:e1576–83.
- Newcombe PA, Sheffield JK, Chang AB. Parent cough-specific quality of life: development and validation of a short form. *J Allergy Clin Immunol* 2013;131:1069–74.
- Ghezzi M, Guida E, Ullmann N, Sacco O, Mattioli G, Jasonni V, et al. Weakly acidic gastroesophageal refluxes are frequently triggers in young children with chronic cough. *Pediatr Pulmonol* 2013;48:295–302.
- Stark P, Heenan R, Orsani F, Jachno K, Connell TG. Amoxicillin-clavulanate for chronic wet cough in children: cautious interpretation of study findings warranted. *Thorax* 2013;68:296–7.
- Kompare M, Weinberger M. Protracted bacterial bronchitis in young children: association with airway malacia. *J Pediatr* 2012;160:88–92.
- Cherry JD. Epidemic pertussis in 2012—the resurgence of a vaccine-preventable disease. *N Engl J Med* 2012;367:785–7.
- Lu PJ, Graitcer SB, O'Halloran A, Liang JL. Tetanus, diphtheria and acellular pertussis (Tdap) vaccination among healthcare personnel—United States, 2011. *Vaccine* 2014;32:572–8.
- Klein NP, Bartlett J, Rowhani-Rahbar A, Fireman B, Baxter R. Waning protection after fifth dose of acellular pertussis vaccine in children. *N Engl J Med* 2012;367:1012–19.
- Schaefer MK, Shehab N, Cohen AL, Budnitz DS. Adverse events from cough and cold medications in children. *Pediatrics* 2008;121:783–7.



## REFERENCES

- Marchant JM, Newcombe PA, Juniper EF, Sheffield JK, Stathis SL, Chang AB. What is the burden of chronic cough for families? *Chest* 2008;134:303–9.
- Newcombe PA, Sheffield JK, Juniper EF, Marchant JM, Halsted RA, Masters IB, et al. Development of a parent-proxy quality-of-life chronic cough-specific questionnaire: clinical impact vs psychometric evaluations. *Chest* 2008;133:386–95.
- From the Centers for Disease Control and Prevention. Pertussis—United States, 1997–2000. *JAMA* 2002;287:977–9.
- Powell CV, Primhak RA. Stability of respiratory symptoms in unlabelled wheezy illness and nocturnal cough. *Arch Dis Child* 1996;75:385–91.
- Irwin RS, Madison JM. The diagnosis and treatment of cough. *N Engl J Med* 2000;343:1715–21.
- Chang AB, Robertson CF, Van Asperen PP, Glasgow NJ, Mellis CM, Masters IB, et al. A multicenter study on chronic cough in children: burden and etiologies based on a standardized management pathway. *Chest* 2012;142:943–50.
- Irwin RS, Baumann MH, Bolser DC, Boulet LP, Braman SS, Brightling CE, et al. Diagnosis and management of cough executive summary: ACCP evidence-based clinical practice guidelines. *Chest* 2006;129(1 Suppl.):1S–23S.
- Chang AB, Robertson CF, van Asperen PP, Glasgow NJ, Masters IB, Teoh L, et al. A cough algorithm for chronic cough in children: a multicenter, randomized controlled study. *Pediatrics* 2013;131:e1576–83.
- Newcombe PA, Sheffield JK, Chang AB. Parent cough-specific quality of life: development and validation of a short form. *J Allergy Clin Immunol* 2013;131:1069–74.
- Lister SM, Jorm LR. Parental smoking and respiratory illnesses in Australian children aged 0–4 years: ABS 1989–90 National Health Survey results. *Aust N Z J Public Health* 1998;22:781–6.
- Milgrom H, Wood RI, Ingram D. Respiratory conditions that mimic asthma. *Immunol Allergy Clin North Am* 1998;18:113–32.
- Ghezzi M, Guida E, Ullmann N, Sacco O, Mattioli G, Jasonni V, et al. Weakly acidic gastroesophageal refluxes are frequently triggers in young children with chronic cough. *Pediatr Pulmonol* 2013;48:295–302.
- Boren EJ, Teuber SS, Gershwin ME. A review of non-cystic fibrosis pediatric bronchiectasis. *Clin Rev Allergy Immunol* 2008;34:260–73.
- Munyard P, Bush A. How much coughing is normal? *Arch Dis Child* 1996;74:531–4.
- Chang AB, Asher MI. A review of cough in children. *J Asthma* 2001;38:299–309.
- Falconer A, Oldman C, Helms P. Poor agreement between reported and recorded nocturnal cough in asthma. *Pediatr Pulmonol* 1993;15:209–11.
- Shann F. How often do children cough? *Lancet* 1996;348:699–700.
- Dales RE, White J, Bhumgara C, McMullen E. Parental reporting of children's coughing is biased. *Eur J Epidemiol* 1997;13:541–5.
- Chang AB. Cough, cough receptors, and asthma in children. *Pediatr Pulmonol* 1999;28:59–70.
- Helmert SL, Wheless JW, Frost M, Gates J, Levisohn P, Tardo C, et al. Vagus nerve stimulation therapy in pediatric patients with refractory epilepsy: retrospective study. *J Child Neurol* 2001;16:843–8.
- Irwin RS, Rosen MJ, Braman SS. Cough. A comprehensive review. *Arch Intern Med* 1977;137:1186–91.
- Cough and wheeze in asthma: are they interdependent? *Lancet* 1988;1:447–8.
- Leith DE. Cough. *Phys Ther* 1968;48:439–47.
- Chausow AM, Banner AS. Comparison of the tussive effects of histamine and methacholine in humans. *J Appl Physiol* 1983;55:541–6.
- Eschenbacher WL, Boushey HA, Sheppard D. Alteration in osmolarity of inhaled aerosols cause bronchoconstriction and cough, but absence of a permeant anion causes cough alone. *Am Rev Respir Dis* 1984;129:211–15.
- Fuller RW, Karlsson JA, Choudry NB, Pride NB. Effect of inhaled and systemic opiates on responses to inhaled capsaicin in humans. *J Appl Physiol* 1988;65:1125–30.
- McFadden ER Jr, Nelson JA, Skowronski ME, Lenner KA. Thermally induced asthma and airway drying. *Am J Respir Crit Care Med* 1999;160:221–6.
- Chang AB, Harrhy VA, Simpson J, Masters IB, Gibson PG. Cough, airway inflammation, and mild asthma exacerbation. *Arch Dis Child* 2002;86:270–5.
- Lemanske RF Jr. Inflammation in childhood asthma and other wheezing disorders. *Pediatrics* 2002;109(2 Suppl.):368–72.
- Baker RR, Mishoe SC, Zaitoun FH, Arant CB, Lucas J, Rupp NT. Poor perception of airway obstruction in children with asthma. *J Asthma* 2000;37:613–24.
- Kelly YJ, Brabin BJ, Milligan PJ, Reid JA, Heaf D, Pearson MG. Clinical significance of cough and wheeze in the diagnosis of asthma. *Arch Dis Child* 1996;75:489–93.
- McKenzie S. Cough—but is it asthma? *Arch Dis Child* 1994;70:1–2.
- Chang AB. Isolated cough: probably not asthma. *Arch Dis Child* 1999;80:211–13.
- Davies MJ, Fuller P, Picciotto A, McKenzie SA. Persistent nocturnal cough: randomised controlled trial of high dose inhaled corticosteroid. *Arch Dis Child* 1999;81:38–44.
- Chang AB, Powell CV. Non-specific cough in children: diagnosis and treatment. *Hosp Med* 1998;59:680–4.
- Ninan TK, Macdonald L, Russell G. Persistent nocturnal cough in childhood: a population based study. *Arch Dis Child* 1995;73:403–7.
- Moeller A, Diefenbacher C, Lehmann A, Rochat M, Brooks-Wildhaber J, Hall GL, et al. Exhaled nitric oxide distinguishes between subgroups of preschool children with respiratory symptoms. *J Allergy Clin Immunol* 2008;121:705–9.
- Wright AL, Holberg CJ, Morgan WJ, Taussig LM, Halonen M, Martinez FD. Recurrent cough in childhood and its relation to asthma. *Am J Respir Crit Care Med* 1996;153(4 Pt 1):1259–65.
- Brooke AM, Lambert PC, Burton PR, Clarke C, Luyt DK, Simpson H. Recurrent cough: natural history and significance in infancy and early childhood. *Pediatr Pulmonol* 1998;26:256–61.
- Chang AB. Cough. *Pediatr Clin North Am* 2009;56:19–31, ix.
- Shields MD, Doherty GM. Chronic cough in children. *Paediatr Respir Rev* 2013;14:100–5, quiz 6, 37–8.
- Stark P, Heenan R, Orsani F, Jachno K, Connell TG. Amoxicillin-clavulanate for chronic wet cough in children: cautious interpretation of study findings warranted. *Thorax* 2013;68:296–7.
- Kompare M, Weinberger M. Protracted bacterial bronchitis in young children: association with airway malacia. *J Pediatr* 2012;160:88–92.
- Zimmerman B, Silverman FS, Tarlo SM, Chapman KR, Kubay JM, Urch B. Induced sputum: comparison of postinfectious cough with allergic asthma in children. *J Allergy Clin Immunol* 2000;105:495–9.
- French CL, Irwin RS, Curley FJ, Krikorian CJ. Impact of chronic cough on quality of life. *Arch Intern Med* 1998;158:1657–61.
- Yanney M, Vyas H. The treatment of bronchiolitis. *Arch Dis Child* 2008;93:793–8.
- Law BJ, Carbonell-Estrany X, Simoes EA. An update on respiratory syncytial virus epidemiology: a developed country perspective. *Respir Med* 2002;96(Suppl. B):S1–7.
- Schlesinger C, Koss MN. Bronchiolitis: update 2001. *Curr Opin Pulm Med* 2002;8:112–16.
- McBride JT, McConnochie KM. RSV, recurrent wheezing, and ribavirin. *Pediatr Pulmonol* 1998;25:145–6.
- Stein MT, Harper G, Chen J. Persistent cough in an adolescent. *J Dev Behav Pediatr* 1999;20:434–6, discussion 436–8.
- Castro M, Schweiger T, Yin-Declue H, Ramkumar TP, Christie C, Zheng J, et al. Cytokine response after severe respiratory syncytial virus bronchiolitis in early life. *J Allergy Clin Immunol* 2008;122:726–33, e3.
- Backman K, Piippo-Savolainen E, Ollikainen H, Koskela H, Korppi M. Increased asthma risk and impaired quality of life after bronchiolitis or pneumonia in infancy. *Pediatr Pulmonol* 2014;49:318–25.
- Fernald GW, Collier AM, Clyde WA Jr. Respiratory infections due to *Mycoplasma pneumoniae* in infants and children. *Pediatrics* 1975;55:327–35.
- Murphy CG, van de Pol AC, Harper MB, Bachur RG. Clinical predictors of occult pneumonia in the febrile child. *Acad Emerg Med* 2007;14:243–9.
- Sabato AR, Martin AJ, Marmion BP, Kok TW, Cooper DM. *Mycoplasma pneumoniae*: acute illness, antibiotics, and subsequent pulmonary function. *Arch Dis Child* 1984;59:1034–7.
- Cherry JD. Epidemic pertussis in 2012—the resurgence of a vaccine-preventable disease. *N Engl J Med* 2012;367:785–7.
- Plotkin SA. The pertussis problem. *Clin Infect Dis* 2014;58:830–3.
- Lu PJ, Graitcer SB, O'Halloran A, Liang JL. Tetanus, diphtheria and acellular pertussis (Tdap) vaccination among healthcare personnel—United States, 2011. *Vaccine* 2014;32:572–8.
- National and state vaccination coverage among adolescents aged 13–17 years—United States, 2012. *MMWR Morb Mortal Wkly Rep* 2013;62:685–93.
- Vaccination coverage among children in kindergarten – United States, 2012–13 school year. *MMWR Morb Mortal Wkly Rep* 2013;62:607–12.
- Klein NP, Bartlett J, Rowhani-Rahbar A, Fireman B, Baxter R. Waning protection after fifth dose of acellular pertussis vaccine in children. *N Engl J Med* 2012;367:1012–19.

62. Kuncio DE, Middleton M, Cooney MG, Ramos M, Coffin SE, Feemster KA. Health care worker exposures to pertussis: missed opportunities for prevention. *Pediatrics* 2014;133:15–21.
63. Khetsuriani N, Bisgard K, Prevots DR, Brennan M, Wharton M, Pandya S, et al. Pertussis outbreak in an elementary school with high vaccination coverage. *Pediatr Infect Dis J* 2001;20:1108–12.
64. Versteegh FG, Schellekens JF, Nagelkerke AF, Roord JJ. Laboratory-confirmed reinfections with *Bordetella pertussis*. *Acta Paediatr* 2002;91:95–7.
65. Birkebaek NH, Kristiansen M, Seefeldt T, Degn J, Moller A, Heron I, et al. *Bordetella pertussis* and chronic cough in adults. *Clin Infect Dis* 1999;29:1239–42.
66. Lebel MH, Mehra S. Efficacy and safety of clarithromycin versus erythromycin for the treatment of pertussis: a prospective, randomized, single blind trial. *Pediatr Infect Dis J* 2001;20:1149–54.
67. Cooper WO, Griffin MR, Arbogast P, Hickson GB, Gautam S, Ray WA. Very early exposure to erythromycin and infantile hypertrophic pyloric stenosis. *Arch Pediatr Adolesc Med* 2002;156:647–50.
68. Goldstein LH, Berlin M, Tsur L, Bortnik O, Binyamini L, Berkovitch M. The Safety of Macrolides During Lactation. *Breastfeed Med* 2009;4:197–200.
69. Chen CJ, Wu KG, Tang RB, Yuan HC, Soong WJ, Hwang BT. Characteristics of *Chlamydia trachomatis* infection in hospitalized infants with lower respiratory tract infection. *J Microbiol Immunol Infect* 2007;40:255–9.
70. Eamranond P, Jaramillo E. Tuberculosis in children: reassessing the need for improved diagnosis in global control strategies. *Int J Tuberc Lung Dis* 2001;5:594–603.
71. American Academy of Pediatrics. Tuberculosis. In: Pickering L, editor. Report of the Committee on Infectious Diseases. Elk Grove Village, IL: 2003.
72. Andrews T, Myer C, Bailey W. Intrathoracic lesions involving the tracheobronchial tree. In: Myer C, Cotton R, Shott S, editors. *The Pediatric Airway: An Interdisciplinary Approach*. Philadelphia: JB Lippincott; 1995.
73. Oermann CM, Moore RH. Foolers: things that look like pneumonia in children. *Semin Respir Infect* 1996;11:204–13.
74. Condino AA, Sondheimer J, Pan Z, Gralla J, Perry D, O'Connor JA. Evaluation of gastroesophageal reflux in pediatric patients with asthma using impedance-pH monitoring. *J Pediatr* 2006;149:216–19.
75. McGeady S. GERD and airways disease in children and adolescents. In: Stein M, editor. *Gastroesophageal Reflux Disease and Airway Disease*. New York: Marcel Dekker; 1999.
76. Block BB, Brodsky L. Hoarseness in children: the role of laryngopharyngeal reflux. *Int J Pediatr Otorhinolaryngol* 2007;71:1361–9.
77. Rothenberg SS, Bratton D, Larsen G, Deterding R, Milgrom H, Brugman S, et al. Laparoscopic fundoplication to enhance pulmonary function in children with severe reactive airway disease and gastroesophageal reflux disease. *Surg Endosc* 1997;11:1088–90.
78. Cohen SR, Herbert WI, Lewis GB Jr, Geller KA. Foreign bodies in the airway. Five-year retrospective study with special reference to management. *Ann Otol Rhinol Laryngol* 1980;89(5 Pt 1):437–42.
79. Marcinow AM, Thompson J, Chiang T, Forrest LA, deSilva BW. Paradoxical vocal fold motion disorder in the elite athlete: experience at a large division I university. *Laryngoscope* 2014;124:1425–30.
80. Landwehr LP, Wood RP 2nd, Blager FB, Milgrom H. Vocal cord dysfunction mimicking exercise-induced bronchospasm in adolescents. *Pediatrics* 1996;98:971–4.
81. Chung KF, Chang AB. Therapy for cough: active agents. *Pulm Pharmacol Ther* 2002;15:335–8.
82. Pattenden S, Antova T, Neuberger M, Nikiforov B, De Sario M, Grize L, et al. Parental smoking and children's respiratory health: independent effects of prenatal and postnatal exposure. *Tob Control* 2006;15:294–301.
83. Joad JP. Smoking and pediatric respiratory health. *Clin Chest Med* 2000;21:37–46.
84. Burr ML, Anderson HR, Austin JB, Harkins LS, Kaur B, Strachan DP, et al. Respiratory symptoms and home environment in children: a national survey. *Thorax* 1999;54:27–32.
85. Dales RE, Zwahlenburg H, Burnett R, Franklin CA. Respiratory health effects of home dampness and molds among Canadian children. *Am J Epidemiol* 1991;134:196–203.
86. Strachan DP, Elton RA. Relationship between respiratory morbidity in children and the home environment. *Fam Pract* 1986;3:137–42.
87. Pandolfini C, Impicciatore P, Bonati M. Parents on the web: risks for quality management of cough in children. *Pediatrics* 2000;105:e1.
88. Sharfstein JM, North M, Serwint JR. Over the counter but no longer under the radar—pediatric cough and cold medications. *N Engl J Med* 2007;357:2321–4.
89. Schaefer MK, Shehab N, Cohen AL, Budnitz DS. Adverse events from cough and cold medications in children. *Pediatrics* 2008;121:783–7.
90. Vernacchio L, Kelly JP, Kaufman DW, Mitchell AA. Pseudoephedrine use among US children, 1999–2006: results from the Slone survey. *Pediatrics* 2008;122:1299–304.
91. FDA halts sales of some anti-vomiting suppositories ... and are cough medications effective in children? *Child Health Alert* 2007;25:1–2.
92. Rimsza ME, Newberry S. Unexpected infant deaths associated with use of cough and cold medications. *Pediatrics* 2008;122:e318–22.

# Immunology of the Asthmatic Response

OSCAR PALOMARES | CEZMI A. AKDIS

## KEY POINTS

- Asthma is a complex syndrome that includes many disease phenotypes and endotypes.
- Allergic asthma and Type 2 asthma represent the most common phenotype with lung eosinophilia. Both ILC2 and Th2 cells, as well as type 2 cytokine-producing natural killer (NK) T cells, may contribute to this form.
- In addition to Th1 and Th2 cells, other T cell subsets contribute to the development of allergic asthma at different stages including Th1, Th17, Th9, Th22 and different populations of T<sub>REG</sub> cells.
- The innate immune system participates in the initiation and maintenance of both allergic and nonallergic asthma. Activated NKT cells in the lung produce proinflammatory cytokines contributing to bronchial hyperreactivity.
- Epithelial cell activation essentially contributes to the inflammatory burden.
- Remodeling in asthma includes basement membrane thickening, myofibroblast differentiation, smooth muscle hyperplasia, epithelial activation and angiogenesis, and is controlled by the immune system.
- Immune tolerance with the induction of T and B regulatory cells is effective in treatment and prevention in mouse models and represents the major mechanism of action of allergen-specific immunotherapy (AIT) for the treatment of allergic rhinitis and asthma in humans.

Asthma is a very common chronic disorder of the airways characterized by variable and recurring symptoms, airflow obstruction, bronchial hyperresponsiveness (BHR) and underlying inflammation.<sup>1-3</sup> It is a complex syndrome that develops after environmental exposures such as innocuous allergens, infectious agents and air pollutants in genetically susceptible individuals with differences in severity, co-morbidities, natural history and treatment response.<sup>4</sup> The asthma syndrome encompasses several disease subtypes defined by distinct pathophysiologic mechanisms, called endotypes.<sup>3</sup> Some examples of these asthma endotypes include aspirin-sensitive asthma (ASA), allergic bronchopulmonary mycosis (ABPM), allergic asthma, asthma predictive indices (API), late-onset asthma in adulthood and cross-country skier's asthma. Among them, allergic asthma is one of the best characterized. Recent advances have significantly contributed to our knowledge of the mechanisms underlying this endotype. It is characterized by an inflammatory immune response with high levels of T helper cell type 2 (Th2)

lymphocytes, type 2 innate lymphoid cells, eosinophils and basophils together with activation of the tissue cells, particularly epithelium and smooth muscle cells, that leads to mucus production, mucosal edema, reversible airway obstruction, BHR and airway remodeling. Allergic asthma is associated with specific IgE sensitization to indoor and outdoor allergens,<sup>5,6</sup> and sometimes with elevated total serum IgE levels,<sup>7</sup> which represent major risk factors for the development of asthma and persistent wheezing in children.<sup>8</sup>

## Mechanisms of the Allergic Inflammatory Response

The immune response in allergic asthma consists of two main phases: (1) sensitization and memory and (2) the effector phase, which can be further subdivided into the immediate-phase response (IPR) and the late-phase response (LPR).<sup>9</sup> During the sensitization phase of asthma the differentiation and clonal expansion of allergen-specific CD4<sup>+</sup> Th2 cells producing IL-4 and IL-13 are essential to induce class switch to the  $\epsilon$  immunoglobulin heavy chain in B cells and the production of allergen-specific IgE antibodies (Abs). Allergen-specific IgE binds to the high-affinity Fc $\epsilon$ RI on the surface of mast cells and basophils, thus leading to the patient's sensitization (Figure 28-1). A memory pool of allergen-specific T and B cells is also generated. The IPR, which is also called the type I hypersensitivity response, occurs after new encounters with the causative allergen, which induces cross-linking of the IgE-Fc $\epsilon$ RI complexes on sensitized effector cells, leading to the release of anaphylactogenic mediators responsible for the classical symptoms of IPR, which induce increased vascular permeability, extravasation of fluid into the tissues and smooth muscle contraction (Figure 28-2). If contact with the allergen persists, the LPR occurs 6 to 12 hours later. Activated allergen-specific Th2 cells produce IL-4, IL-5, IL-9 and IL-13, which play a key role in the maintenance of allergen-specific IgE levels, eosinophilia, recruitment of inflammatory cells to inflamed tissues, production of mucus and decreased threshold of contraction of smooth muscles, leading to increased inflammation associated with BHR, a cardinal feature of asthma (Figure 28-2).<sup>10,11</sup> Recently, other cytokines including thymic stromal lymphopoietin (TSLP), IL-25, IL-31 and IL-33 produced in epithelial cells have been shown to participate in the Th2 response and inflammation.<sup>12-14</sup>

## Th2 CELLS AND Th2 CYTOKINES

CD4<sup>+</sup> Th2 cells are present in lung biopsy specimens and bronchoalveolar lavage (BAL) fluid from patients with allergic asthma and play a prominent role in the initiation and

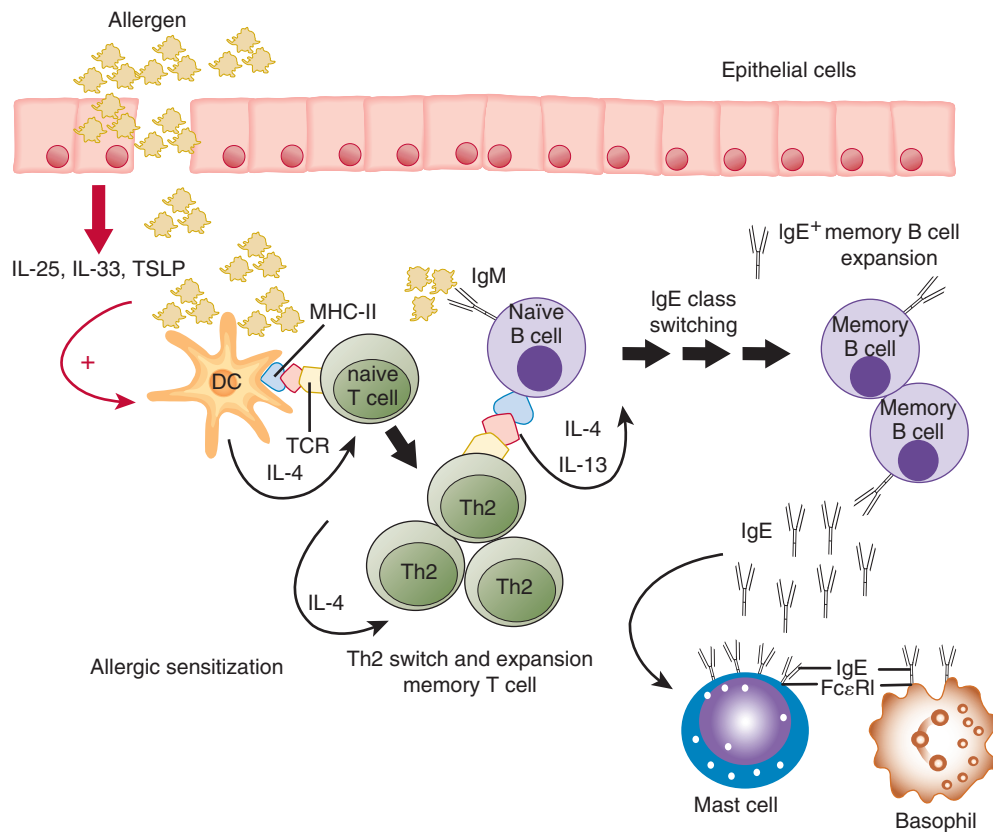

**Figure 28-1** Schematic representation of the sensitization phase in asthma. Allergen-specific CD4<sup>+</sup> Th2 cells producing IL-4 and IL-13 are generated in a process depending on dendritic cells (DCs). Epithelial cell-derived thymic stromal lymphopoiectin (TSLP), IL-25 and IL-33 may play a role in this Th2 response. Th2 cells contribute to the IgE class switching on B cells. IgE binds to FcεRI on mast cells and basophils, the effector cells, thus leading to the allergic sensitization of patients.

development of the disease. Although several cell types produce Th2 cytokines, including mast cells, basophils, natural killer T (NKT) cells and the recently identified type 2 innate lymphoid cells (ILC2), Th2 lymphocytes are still considered fundamental in allergic asthma. Initially, mouse models demonstrated that depletion of CD4<sup>+</sup> T cells prevents the development of asthma.

IL-4 plays a major role in the development of protective immune responses to helminths and other extracellular parasites,<sup>15</sup> but it also has a central role in the regulation of allergic asthma, being the major stimulus for the differentiation of antigen-stimulated naïve T cells into Th2 cells.<sup>16–18</sup> IL-4 is also essential for human and mouse B cell switch to IgE and IgG4 or IgG1, respectively, and increases the expression of class II MHC molecules, CD23 and IL-4R in B cells. IL-4 increases the production of cysteinyl leukotrienes from IgE-primed mast cells,<sup>19</sup> and together with TNF- $\alpha$  the expression of vascular cell adhesion molecule-1 (VCAM-1) on vascular endothelial cells. IL-4- and IL-4R $\alpha$ -deficient mice have severely compromised Th2 differentiation and their serum levels of IgG1 and IgE are strongly reduced.<sup>20</sup>

IL-5 is another central Th2 cytokine, which is simultaneously produced with IL-4 under the control of the transcription factor GATA-3 with a central role in allergic asthma.<sup>21</sup> IL-5, together with IL-3 and granulocyte-macrophage colony-stimulating factor (GM-CSF), leads to growth, activation, differentiation, survival and mobilization of eosinophils to the lungs as a key feature of asthma.<sup>22–25</sup> Eotaxin-2, an eosinophil chemokine, seems to be crucial for IL-5-induced IL-13

production and BHR and has a role in remodeling.<sup>26,27</sup> IL-5 levels and eosinophils are increased in BAL and in biopsies of asthmatics and they correlate with severity of the disease.<sup>28</sup> Eosinophils produce cysteinyl leukotrienes and may enhance the production of IL-13,<sup>29</sup> which can directly induce BHR. IL-5-deficient mice are resistant to induction of experimental asthma.<sup>30</sup> The treatment of asthma with anti-IL-5 antibodies (mepolizumab, reslizumab) reduced blood eosinophilia and sputum eosinophils, but few or no effects on asthma symptoms were observed in the initial clinical trials.<sup>31–33</sup> Recent studies reported significant reductions in exacerbation rates in refractory eosinophilic asthma<sup>34</sup> and steroid-dependent asthma with sputum eosinophilia.<sup>35</sup>

IL-13 is another Th2 cytokine that has been shown to play a critical role in asthma.<sup>16</sup> IL-13 shares with IL-4 one receptor chain, IL-4R $\alpha$ . IL-13 does not promote Th2 differentiation, because T cells do not express the IL-13 receptor. IL-13 is also able to activate eosinophils and mast cells, recruits eosinophils and prolongs their survival.<sup>36</sup> It up-regulates the levels of CD23 and MHC II on B-cells and induces the expression of different adhesion molecules on monocytes. IL-13 also plays an important role in tissue remodeling and fibrosis, and TGF- $\beta$  has been linked to these effects.<sup>37,38</sup> The role of IL-13 in asthma is supported by epidemiologic data showing that IL-13 polymorphisms lead to a higher frequency of asthma exacerbations in childhood and elevated total IgE and blood eosinophilia.<sup>39</sup> IL-13 knockout mice fail to mount a profound goblet cell hyperplasia without affecting IL-4- and IL-5-producing cells,



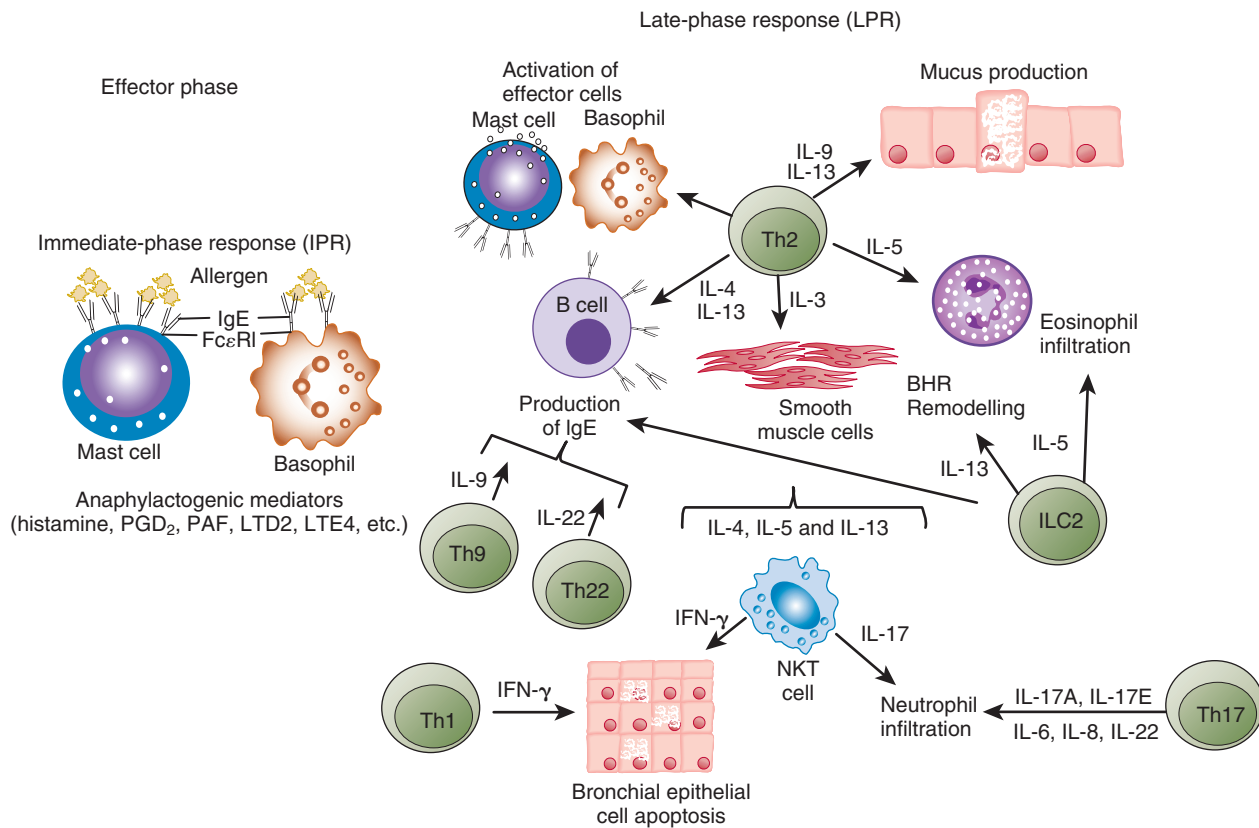

**Figure 28-2** Schematic representation of the effector phases, the immediate-phase response (IPR) and the late-phase response (LPR), in asthma. In the LPR, the contribution of Th2 cells and other cell subsets including Th1, Th17, Th9, Th22, NKT cells and ILC2 is shown. Type 2 immunity of Th2 cells and ILC2 play a major role by producing the Th2 type effector cytokines such as IL-4, IL-5, IL-9 and IL-13. IL-4 and IL-13 are important in IgE production, whereas IL-5 has effects on eosinophil survival, Th1 cells and IFN- $\gamma$  affect epithelial apoptosis and shedding, Th17 cells impact on neutrophilic inflammation, and IL-9 on mucus production.

mast cell cytokine production and IgE levels.<sup>40,41</sup> Specific over-expression of IL-13 in the lung leads to typical features of asthma.<sup>42</sup> Although all these findings indicate that IL-13 is a critical cytokine required for the development of asthma, an IL-4 mutant protein blocking the binding of both IL-4 and IL-13 to IL-4R $\alpha$  was able to reduce the severity of the LPR, but not BHR in clinical trials.<sup>43</sup> This suggests that other factors, in addition to IL-13/IL-4, function to induce BHR in patients with asthma.

### THE DEVELOPMENT OF THE Th2 RESPONSE

There are two types of IL-4 binding receptors: the type I and type II IL-4R.<sup>44</sup> Both types have the IL-4R $\alpha$  chain in common. Type I IL-4R binds IL-4 exclusively and consists of IL-4R $\alpha$  (CD124) and the common gamma chain  $\gamma$ c (CD132), which is also a receptor for IL-2, IL-7, IL-9, IL-15 and IL-21. Type II IL-4R binds IL-4 and also IL-13 and consists of the IL-4R $\alpha$  chain and the IL-13R $\alpha$ 1 chain.<sup>45</sup> Whereas the signals of the type II IL-4R are mediated by signal transduction and activator of transcription (STAT3), the signals of the type I IL-4R are transduced by STAT6. Binding of IL-4 to the IL-4 receptor complex promotes intracellular signaling cascades involving several Jaks members that culminate with the phosphorylation and activation of STAT6 that enhance Th2 cell differentiation. The binding of IL-13 to its receptors, which consist of IL-13R $\alpha$ 1 and IL-13R $\alpha$ 2 and the IL-4R $\alpha$  chain, also results in phosphorylation of STAT-6.

STAT-6 then translocates to the nucleus and binds to STAT-6 transcriptional elements or interacts with additional Th2-associated transcription factors such as GATA-3, which is selectively expressed in Th2 cells and is critical for Th2 cytokine expression.<sup>46</sup> Increased expression of both STAT-6 and GATA-3 has been observed in bronchial mucosa of asthmatic patients.<sup>47,48</sup>

### THE Th1/Th2 PARADIGM

After the discovery of Th1 and Th2 cells in 1986,<sup>49</sup> it was suggested that a Th2 response underlies the development of allergic diseases, and that Th1 responses are predominant in infections and autoimmunity (Figure 28-3). Following these initial findings, the general dogma was that a switch toward a Th1 response would be required for successful treatment of allergies by AIT and a switch toward a Th2 response would be beneficial for treatment of autoimmunity. Th1 cells secrete IFN- $\gamma$ , particularly induced by IL-12, which is secreted from dendritic cells (DCs). Th2 cells secrete IL-4, IL-5 and IL-13 induced by IL-4. Th1 cells were thought to balance Th2 responses and protect against allergic diseases, as has been shown in models of infection with intracellular bacteria. In humans, infants with higher levels of IFN- $\gamma$  in their cord blood were demonstrated to be less likely to develop atopy.<sup>50</sup> Furthermore, expression of T-bet, the master switch transcription factor for Th1 development and IFN- $\gamma$  production, is decreased in the airways of patients with asthma.<sup>51</sup> Moreover, patients with allergic asthma display low

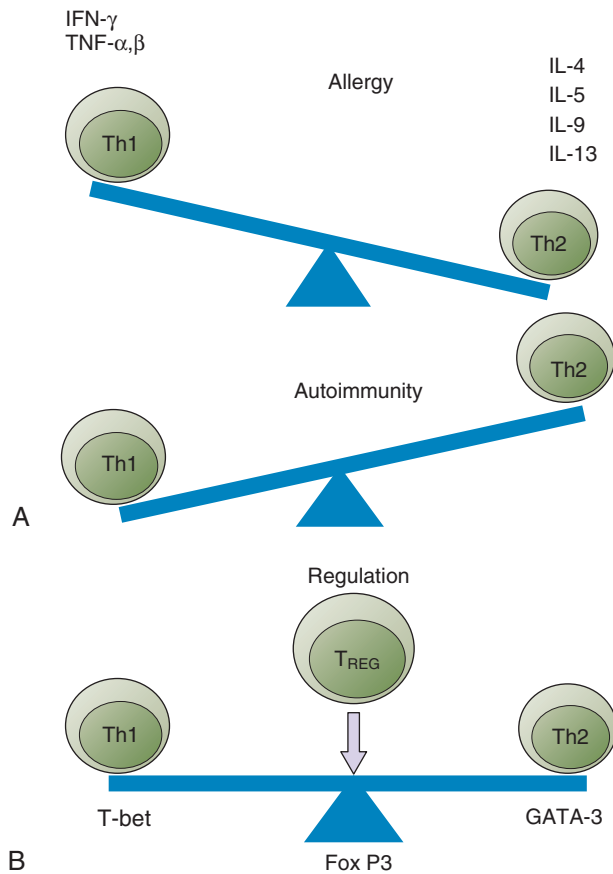

	Th1	T <sub>REG</sub>	Th2
Transcription factors	T-bet	FoxP3	GATA-3
Major functions	Delayed type of hypersensitivity, macrophage activation Limited B cell help/inhibition	Inhibition of Th1 and Th2 cells Inhibition of mo/mac Inhibition of DC maturation Peripheral tolerance	Chronic eosinophilic inflammation with high IgE
Beneficial role	Chronic intracellular infections Leishmaniasis Leprosy Virus infections	Immunotherapy Transplantation Autoimmunity Allergy/asthma Pregnancy	Arthritis Autoimmunity Helminth infection Pregnancy

**Figure 28-3** Th1, Th2 and T<sub>REG</sub> cells. After the discovery of Th1 and Th2 cell subsets in 1986, it was thought that Th1 cells play a role in infections and autoimmunity and Th2 cells in allergic disease. Both subsets were thought to have reciprocal roles in counter-regulating the other. Although there is reciprocal regulation between individual Th cell subsets, T<sub>REG</sub> cells play a major role in immune tolerance in allergy, autoimmunity, organ transplantation, cancer, pregnancy and chronic infections.

levels of the Th1-driven cytokine IL-12,<sup>52</sup> as well as lower expression of IL-12R.<sup>53</sup>

### Beyond the Th2 Paradigm in Allergies and Asthma

The Th2 paradigm of asthma explains many features of asthma, but there are many other observations that cannot be explained exclusively by this paradigm. For example, non-Th2 factors such as IFN- $\gamma$ , neutrophils and IL-17 are present in the airways of many patients with asthma, particularly patients with severe asthma and corticosteroid-resistant asthma, suggesting that IFN- $\gamma$  and IL-17 are proinflammatory cytokines. Depending on the stage of inflammation they contribute to ongoing allergic asthma and Th1 and Th17 are not necessarily polarized as cells that oppose Th2 cells (Figure 28-2). It was demonstrated that Th1 cells contribute to exacerbation of the LPR by inducing apoptosis of the airway epithelium in atopic patients,<sup>54,55</sup> and that neutralization of IL-17 and Th17-related functions in an experimental asthma model reduces neutrophilia, while increasing eosinophil infiltration in the lung.<sup>56</sup> In addition, two novel Th cell subsets have been identified according to their cytokine signature, Th9 and Th22 cells (Figure 28-2). However, their exact contribution to the initiation and continuation of allergic asthma needs to be further explored.<sup>57-59</sup> The prevalence of

Th1- and Th17-mediated autoimmune diseases such as type 1 diabetes, inflammatory bowel disease and multiple sclerosis has significantly increased, as has that of atopic diseases, in westernized cultures over the past decades. This might be partially explained by environmental changes that have occurred in westernized cultures that could have altered the function of a specific T cell population with suppressive capacity – regulatory T cells (T<sub>REG</sub>; see below) – thus enhancing the development of not only Th2- but also Th1- and Th17-mediated diseases.

Other observations that cannot be explained by the Th2 paradigm of asthma are: (1) low levels of Th2 cells in the airways of patients with severe asthma and with steroid-resistant asthma; (2) that viral infection, exercise and air pollution are common nonallergic factors that normally induce symptoms of asthma; (3) that only around 30% to 40% of patients with allergic rhinitis develop asthma; (4) therapies targeting Th2 factors in clinical trials have not always been as effective as predicted.<sup>5,60</sup> Therefore, other innate and adaptive inflammatory pathways must be considered beyond the Th1/Th2 paradigm to explain the development of asthma.

### NEW T CELL SUBSETS

#### Regulatory T Cells and Immune Tolerance

T<sub>REG</sub> cells comprise a group of different T cell subsets with suppressive capacity that are essential for the induction of immune

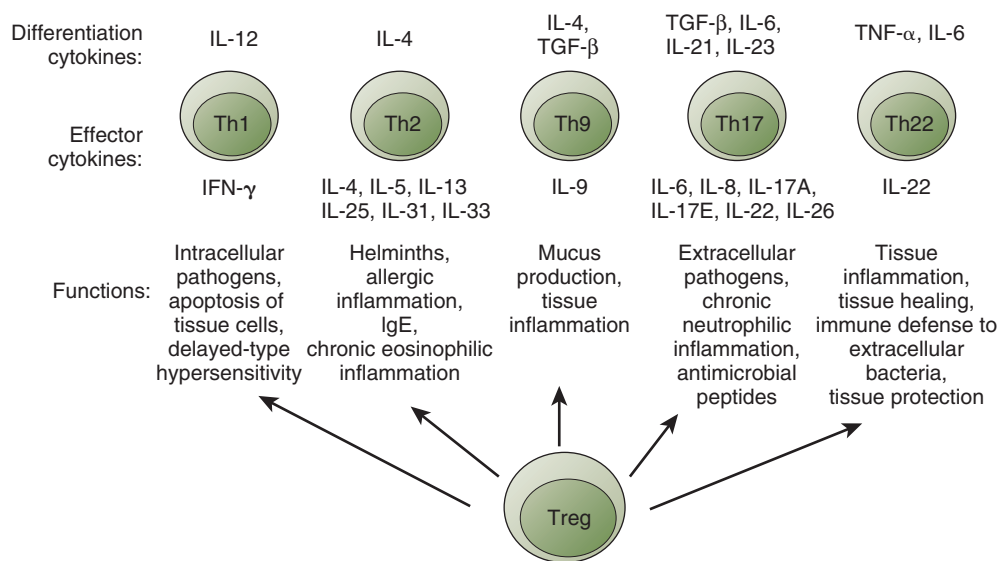

**Figure 28-4** Antigen presentation by dendritic cells to naïve T cells and other factors (innate immune response substances, vitamins, cytokines in the environment) induce the T cells to produce interleukins and differentiate into Th1, Th2, Th9, Th17 or Th22 cells. These T cell subsets can promote different types of inflammatory responses based on their respective cytokine profiles, responses to chemokines and interactions with other cells. T<sub>REG</sub> cells directly or indirectly suppress all other effector T cell subsets.

tolerance (Figure 28-4).<sup>61</sup> T<sub>REG</sub> cells can be broadly divided into two main groups: (1) the thymus-derived naturally occurring CD4<sup>+</sup>CD25<sup>+</sup> forkhead box protein 3 (FOXP3)<sup>+</sup> T<sub>REG</sub> cells, also called natural T<sub>REG</sub> (nT<sub>REG</sub>) cells, and (2) the inducible T<sub>REG</sub> (iT<sub>REG</sub>) cells. nT<sub>REG</sub> cells constitutively express high levels of the alpha chain of the IL-2 receptor (CD25) and the suppressor costimulatory molecules CTLA4 and PD1.<sup>62,63</sup> The expression levels of GITR, CD103 and CD122 on nT<sub>REG</sub> cells correlate with their suppressive activity.<sup>64</sup> In mice, FOXP3, the master transcription factor for T<sub>REG</sub> cell generation, is specifically expressed by nT<sub>REG</sub> cells,<sup>65,66</sup> but in humans it might be also expressed in activated T cells.<sup>67</sup> Mutations in *FOXP3* lead to the immune dysregulation polyendocrinopathy enteropathy X-linked syndrome (IPEX) or the X-linked autoimmune and allergic dysregulation syndrome (XLAAD), diseases characterized by severe autoimmune and allergic phenotypes.<sup>68,69</sup> Similar phenotypes are reported for scurfy mice due to *FOXP3* mutations and impaired capacity to generate functional T<sub>REG</sub> cells.<sup>70</sup> iT<sub>REG</sub> cells generated in the periphery after antigenic stimulation are characterized by high levels of IL-10 production and play a key role in the maintenance of healthy immune response to allergens.<sup>71,72</sup> iT<sub>REG</sub> cells suppress effector T cell responses by mechanisms that depend on IL-10 and also TGF- $\beta$ , and produce perforin and granzymes to kill antigen-presenting cells.<sup>72</sup> In humans, Type 1 iT<sub>REG</sub> (Tr1) cells inhibited the proliferation and cytokine responses of naïve as well as established Th1 and Th2 cells, including allergen-specific Th2 cell lines.<sup>73</sup> Healthy and allergic individuals display three different allergen-specific T cell subtypes as Th1, Th2 and Tr1 in different ratios.<sup>74,75</sup> The imbalance between Th2 and Tr1 cells, depending on the dominant subset, may induce allergy development or recovery. Immune tolerance to venom allergens is an appropriate model for high-dose tolerance to allergens in humans. During the exposure to venom allergen, venom-specific IL-10-secreting Tr1 cells are clonally differentiated from allergen-specific Th1 and Th2 cells.<sup>71</sup> Interestingly, histamine receptor 2, which is also up-regulated on specific Th2 cells, suppresses allergen-stimulated T cells and

enhances IL-10 production related to the tolerance mechanism. Nonallergic beekeepers have an approximately 1,000 times higher allergen-specific IgG4 versus allergen-specific IgE ratio compared to bee venom allergic individuals.<sup>76</sup> Another tolerance model with cat allergen also showed elevated levels of allergen-specific IgG4 levels after exposure to high-dose cat allergen.<sup>77</sup> This also represents immune tolerance to the Th2 type immune response to specific allergen. Together these outcomes may infer that pets in the house may induce tolerance and decrease the risk of asthma.

Interestingly, it has recently been shown that functional allergen-specific T<sub>REG</sub> cells are generated in human tonsils by mechanisms partially depending on plasmacytoid dendritic cells (pDCs) and that triggering of TLR4 or TLR8 and proinflammatory cytokines, such as IL-1 $\beta$  and IL-6, breaks allergen-specific T cell tolerance in human tonsils and peripheral blood.<sup>78,79</sup> Considering that the relatively large lingual tonsil is not removed by tonsillectomy and remains intact for life, these data suggest that the tonsils are the organs where immune tolerance induction during successful sublingual immunotherapy (SLIT) may take place, thus representing a potential novel target for future therapeutic interventions.

### Th17 Cells

A new T cell lineage secreting large quantities of IL-17A, also known as IL-17, was identified and called Th17 cells.<sup>32,33</sup> Th17 cells are essential for the elimination of extracellular pathogens<sup>80,81</sup> and they might also play a role in the development of psoriasis, Crohn's disease and rheumatoid arthritis.<sup>82</sup> They produce proinflammatory cytokines such as IL-17A, IL-17F, IL-22 or IL-26 after activation.<sup>83–85</sup> The main cytokines involved in Th17 development and expansion include TGF- $\beta$ , IL-6, IL-1 $\beta$ , IL-21 and IL-23.<sup>84,86</sup> The retinoic acid receptor-related orphan receptor  $\gamma$ /C2 (ROR $\gamma$ /RORC2), in mice and humans respectively, is the master transcription factor involved in Th17 cell development.<sup>87</sup> Several studies in mouse models and human data suggest that Th17 cells play a pathogenic role in the

development of allergic diseases.<sup>64,88</sup> Th17 cells contribute to neutrophilic inflammation in acute airway inflammation models.<sup>56,89</sup> IL-17 is demonstrated to be the main cytokine driving the granulocyte influx observed in the lungs of allergic asthma models.<sup>90,91</sup> In humans, it was shown that Th17 cells contribute to allergic airway disease by inducing airway smooth muscle cell migration.<sup>92</sup> Genetic polymorphism studies demonstrated an association of IL-17 and asthma.<sup>93</sup>

### Th9 and Th22 Cells

Recent findings showed that TGF- $\beta$  alone converts Th2 cells into selective producers of IL-9 (Th9), and that in combination with IL-4 it is able to promote the generation of Th9 cells.<sup>47,48</sup> IL-9 significantly contributes to the development of allergic asthma by directly acting on T cells, B cells, mast cells, eosinophils, neutrophils and epithelial cells and promoting eosinophilic inflammation, BHR, elevated IgE levels and increased mucus secretion (Figure 28-2).<sup>94-98</sup> The expression of IL-9 and IL-9 receptor is increased in bronchial tissue of atopic asthmatic subjects.<sup>99</sup> Supporting this role, mice selectively overexpressing IL-9 in the lung developed many features that resembled human asthma.<sup>94,95</sup>

Th22 cells represent a novel Th cell subset characterized by particularly high production of IL-22, which might be also produced by other T cells such as Th0 and Th17 cells.<sup>85,100-102</sup> The exact role of IL-22 in asthma is not fully understood yet and further research is required. It was reported that Th22 cells together with Th17 cells contribute to enhance migration of airway smooth muscle cells, thus increasing the accumulation of such cells in asthma (Figure 28-2).<sup>82,92</sup> As previously discussed, Th17 cells induce BHR in steroid-resistant asthma, but whether this effect might also be partially due to IL-22 remains elusive.<sup>16,103</sup> IL-22 could also inhibit allergic airway inflammation in the effector phase by altering the function of DCs and inhibiting IL-25 production from lung epithelial cells.<sup>104</sup>

### B Regulatory Cells and Allergen Tolerance

Very recent findings demonstrated that IL-10-secreting B regulatory (Br1) cells might also play an essential role in the generation of a healthy immune response to allergens.<sup>105</sup> Human IL-10-secreting Br1 cells are able to suppress antigen-specific CD4<sup>+</sup> T cell proliferation. In addition, the major bee venom allergen phospholipase A (PLA)-specific B cells from nonallergic beekeepers showed increased expression of IL-10 and IgG4 and the frequency of IL-10-secreting PLA-specific B cells increased in allergic patients receiving allergen-specific immunotherapy. These data provide novel information on IL-10-secreting Br1 cells in allergic inflammation in humans.

In a recent study analyzing the role of IL-10 in particular, solely IL-10-overexpressing human B cells acquired a prominent immunoregulatory profile comprising up-regulation of suppressor cytokine signaling-3 (SOCS3), glycoprotein A repetitions predominant (GARP), CD25 and PD-L1.<sup>106</sup> Concurrently, their secretion profile was characterized by a significant reduction in proinflammatory cytokines (TNF- $\alpha$ , IL-8 and MIP-1 $\alpha$ ) and augmented production of antiinflammatory IL-1RA and vascular endothelial growth factor (VEGF). IL-10-overexpressing B cells secreted less IgE, and potentially suppressed proinflammatory cytokines in peripheral blood mononuclear cells, maturation of monocyte-derived dendritic cells (promoting a tolerogenic phenotype) and antigen-specific proliferation in vitro.

## Innate Inflammatory Mechanisms in Asthma

Compelling experimental evidence has demonstrated that asthma does not exclusively depend on Th2 adaptive immune responses, and it is increasingly seen as a disease that has a strong innate immune component. Today, it is accepted that the classical Th2 cytokine signature of allergic asthma might not simply reflect an adaptive Th2 cellular response.<sup>5</sup> Different innate immune system cells in the lung such as epithelial cells, DCs, other airway cells, neutrophils, eosinophils, NK cells and NKT cells as well as ILC2 also significantly contribute to the initiation and maintenance of allergic asthma.<sup>60</sup> In contrast to the adaptive immune system, the response mounted by the innate inflammatory system does not involve memory and is less sensitive to corticosteroids,<sup>107</sup> which could explain the apparent resistance to steroid treatments in many forms of asthma and severe asthma. The innate immune system cells express a wide range of pattern recognition receptors (PRRs) that allow them to recognize molecular patterns released from pathogens (pathogen-associated molecular patterns, PAMPs) or from damaged tissues (damage-associated molecular patterns, DAMPs).<sup>108,109</sup> Innate immune system cells respond to environmental insults such as cigarette smoke that may directly damage respiratory tissues, activating damage PRRs, or to respiratory viruses activating Toll-like receptor (TLR)3, TLR7 or TLR8, which leads to inflammation, and synergize to significantly exacerbate lung inflammation.<sup>109,110</sup> In the same way, other PRRs including C-type lectin receptors, scavenger receptors or nucleotide-binding oligomerization domain (NOD)-like receptors (NLRs) could also contribute to enhance inflammation after exposure to protease-containing allergens, pathogens or pollution.<sup>64</sup> Lung epithelial cells do not only represent a structural barrier, they also contribute to mount proper immune responses by secreting different types of mediators such as chemokines (RANTES/CCL5, eotaxin/CCL11 and MCP-1/CCL2), growth factors (platelet-derived growth factor, fibroblast growth factor and endothelins), nitric oxide that increases airway inflammation,<sup>111</sup> as well as cytokines such as IL-25, IL-33 and TSLP (see below) that may activate innate cells, including mast cells, basophils and NKT cells or ILC2.<sup>5</sup>

IL-25, also known as IL-17E, is a member of the IL-17 cytokine family produced by Th2 polarized T cells<sup>112</sup> and in vitro cultured mast cells<sup>113</sup> and epithelial cells.<sup>114,115</sup> Recent data suggest a crucial role for IL-25 in asthma by favoring the production of Th2 cytokines, enhancing IgE synthesis, inducing mucus production and epithelial hypertrophy or augmenting the numbers of eosinophils in blood.<sup>116</sup> IL-25 mediates its effects through the induction of Th2 cytokine production (IL-4, IL-5 and IL-13) in non-B/non-T (NBNT) c-kit<sup>+</sup>Fc $\epsilon$ RI<sup>-</sup> cells in mesenteric lymph nodes, in a subset of natural killer T (NKT) cells<sup>117</sup> and in ILC2.<sup>118</sup> Eosinophils and basophils from atopic individuals have also been described as sources of IL-25. The latter may maintain reactivity of Th2 central memory cells that express the IL-25R upon stimulation by the innate immune system.<sup>14</sup> In mouse models, IL-25 expressed in the lungs of sensitized mice upon antigen inhalation is sufficient to induce allergic diseases of the airways and administration of anti-IL-25 monoclonal antibodies (mAbs) reduced IL-5 and IL-13 production, eosinophilic infiltration, goblet hyperplasia and BHR.<sup>119</sup>



This indicates that IL-25 is a potent inducer of Th2 type immunity in the lung by its effects on several different cell types.

IL-33 is a cytokine that plays a significant role in the regulation of mucosal immune responses of the airways.<sup>120</sup> It is mainly produced by bronchial epithelial cells, but also by fibroblasts and smooth muscle cells. The receptor for IL-33 is ST2, which is mainly expressed on Th2 cells, mast cells, some NKT cells and mucosal ILC2.<sup>118,121</sup> IL-33 levels are increased in the serum of allergic patients suffering from anaphylaxis and different studies demonstrated that IL-33 potently activates human eosinophils and mediates direct degranulation of mast cells in the absence of allergen.<sup>122,123</sup> In mice, IL-33 is able to generate airway inflammation through a process depending on IL-5-producing T cells but not IL-4.<sup>124</sup> Administration of neutralizing antibodies or transfer of soluble ST2 impairs Th2 type inflammation in asthma in mice.<sup>125,126</sup> Administration of exogenous IL-33 leads to lymphocyte-independent airway hyperreactivity and goblet cell hyperplasia in mice.<sup>120</sup>

Thymic stromal lymphopoietin (TSLP) is another cytokine mainly produced by human lung and skin epithelial cells that acts on DCs, increasing the expression of different costimulatory molecules, including OX40-L, which in turn promotes the generation of IL-4-, IL-5- and IL-13-producing T cells and inhibiting IL-10 and IFN- $\gamma$ .<sup>127</sup> In addition, TSLP-activated DCs induce the production of Th2-attracting chemokines and activation-regulated chemokine (TARC) and monocyte-derived chemokine (MDC). The expression of TSLP is significantly increased in the asthmatic airways and in the skin of atopic dermatitis patients, respectively, and correlates with disease severity.<sup>128,129</sup> These data demonstrate that TSLP is also a Th2-promoting cytokine that significantly contributes to the pathogenesis of human asthma.

## ANTIGEN-PRESENTING CELLS

Antigen-presenting cells (APCs) are able to capture environmental allergens in the airways, skin or mucosa, migrate to the nearest lymph nodes and present the processed antigenic peptides to T cells. The most potent stimulators of naïve T cells are DCs lining the mucous membranes of the airways.<sup>71</sup> In contrast, alveolar macrophages, which are abundant in the lung, phagocytize antigens, but they are not able to up-regulate the expression of CD80 or CD86 costimulatory molecules and actively tolerize CD4<sup>+</sup> T cells. In humans, circulating DCs can be broadly divided into two groups: (1) myeloid dendritic cells (mDCs), and (2) plasmacytoid dendritic cells (pDCs).<sup>130</sup> mDCs can be further divided into type 1 mDCs expressing BDCA1 and type 2 mDCs expressing BDCA3.<sup>131</sup> Both mDCs and pDCs express a different repertoire of TLRs and display a diverse cytokine signature after microbial stimulation.<sup>132</sup> mDCs induce naïve CD4<sup>+</sup> T cells to produce large quantities of IFN- $\gamma$  but few Th2 cytokines, whereas pDCs were initially described as inducer CD4<sup>+</sup> T cells to produce Th2 cytokines but not IFN- $\gamma$ . For a long time, it was believed that only immature or partially mature DCs generate functional T<sub>REG</sub> cells<sup>133</sup> and that mature DCs induce specific effector Th cells after encountering different stimuli in specific environments.<sup>134,135</sup> Recent findings indicate that fully mature pDCs are also able to induce functional T<sub>REG</sub> cells<sup>64,136</sup> in humans, thus indicating that pDCs constitute a unique DC subset exhibiting intrinsic tolerogenic capacity.<sup>78,137,138</sup> In mice, depletion and adoptive transfer of pulmonary pDCs in experiments demonstrated this DC subset to be

essential for the prevention of allergic sensitization and asthma development.<sup>139</sup>

## MAST CELLS AND NEUTROPHILS

Mast cells play a key role in both the IPR and LPR effector phases of allergic asthma.<sup>140</sup> Sensitized mast cells are activated in an IgE-dependent manner after new encounters with the offending allergens contributing to the IPR. Mast cells contribute to the development of BHR in asthmatic individuals, who show significantly higher numbers of activated mast cells compared to healthy individuals.<sup>141</sup> During the LPR, eosinophils, basophils, neutrophils and activated T cells massively infiltrate the exposed areas and trigger potent inflammatory responses which, depending also on the IPR, contribute to the generation of BHR and the chronic symptoms of asthma. IL-17-mediated neutrophil infiltration is a very important feature of severe asthma that has been correlated with disease severity.<sup>142</sup>

## BASOPHILS

In addition to the classical role of basophils during the IPR, several studies have demonstrated that they also express class II MHC molecules and are able to prime naïve CD4<sup>+</sup> T cells into Th2 cells.<sup>143,144</sup> They produce large quantities of IL-4, IL-13 and TSLP<sup>145</sup> and it was shown that they could also play a role in the sensitization phase of allergic asthma by enhancing adaptive immunity and Th2 responses.<sup>143,144</sup> A recent study demonstrated that inflammatory DCs were necessary and sufficient for induction of Th2 immunity and features of asthma, whereas basophils were not required, thus suggesting a model whereby DCs initiate and basophils amplify Th2 immunity to house dust mite allergen.<sup>146</sup>

## NATURAL KILLER T CELLS

Due to their unique expression of the invariant T cell receptor (TCR) and their capacity to rapidly produce cytokines after activation, the natural killer T (NKT) cells are considered as a cell subset belonging to the innate immune system with the capacity to amplify adaptive immune responses. NKT cells might be involved in the development of BHR, and different subsets of NKT cells were described in different models of asthma. For the development of BHR in a model of allergic asthma, NKT cells producing IL-4 and IL-13 were required (Figure 28-2).<sup>147</sup> In an asthma model induced with ozone to mimic air pollution, NKT cells producing IL-17 were required to induce neutrophil infiltration in the airways,<sup>148</sup> however, in a model of virus-induced BHR, CD4<sup>+</sup> NKT cells were required.<sup>149</sup> In both cases, Th2 cells and adaptive immunity were necessary for NKT cells to promote BHR, which might help to explain some forms of nonallergic asthma. The frequency of NKT cells in the lungs of asthma patients appears to be highly variable and related to asthma severity and symptom control.<sup>150</sup>

## NATURAL KILLER CELLS

NK cells encompass different subsets of lymphocytes that do not express CD3, CD4 or CD8. They are essential for killing tumor and virus-infected cells as well as in controlling certain microbial infections. Subsets of NK cells (CD56<sup>bright</sup> CD16<sup>dull</sup>) are able to produce high levels of cytokines including IFN- $\gamma$ , tumor necrosis factor (TNF)- $\alpha$ , TGF- $\beta$ , IL-5, IL-10 and IL-22

after stimulation. NK cells contribute to exacerbate airway inflammation and increase Th2 cytokines and eosinophilia as demonstrated after depletion experiments in a mouse model.<sup>151</sup> In contrast, TLR9-L-activated NK cells produced high levels of IFN- $\gamma$ , suggesting a protective role in the development of asthma.<sup>152</sup> Activated NK cells also produced IL-22, which in turn favored the production of antimicrobial peptides and enhanced epithelial cell integrity.<sup>82</sup> In addition, a tiny NK cell subset that secretes mainly Th2 cytokines but not IFN- $\gamma$  has been shown to contribute to IgE production in humans.<sup>153</sup>

### $\gamma\delta$ CELLS

T cells expressing  $\gamma\delta$  T cell receptors ( $\gamma\delta$  T cells) are normally found in high numbers in mucosal tissues, where the contact with allergenic proteins occurs. Although their main function seems to be associated with the generation of immune responses against bacterial antigens, they were also shown to play an important role in allergic sensitization.<sup>154</sup> After allergen challenge, a population of  $\gamma\delta$  T cells producing Th2-type cytokines was described.<sup>155</sup> In humans, the role of  $\gamma\delta$  T cells in asthma is controversial; some studies report increased  $\gamma\delta$  T cell numbers in BAL fluid from patients with asthma,<sup>156</sup> whereas others show decreased numbers of peripheral blood  $\gamma\delta$  cells.<sup>157</sup>

### CD8<sup>+</sup> T CELLS

CD8<sup>+</sup> T cells can be classified as type 1 (producing IFN- $\gamma$ ) or type 2 (producing IL-4 and IL-5). Exogenous allergens are cross-presented to allergen-specific CD8<sup>+</sup> cells through class I pathways, but the precise role of CD8<sup>+</sup> cells in asthma is not clear and may depend on the relative numbers of both types in the lungs and blood of asthmatic individuals. It was initially suggested that type 2 CD8<sup>+</sup> cells may contribute to asthma pathogenesis.<sup>158</sup> Type 1 CD8<sup>+</sup> cells were shown also to enhance asthma symptoms,<sup>159</sup> but they could also display a protective role by eliminating allergen-specific Th2 cells.

### TYPE 2 INNATE LYMPHOID CELLS (ILC2)

Type 2 innate lymphoid cells (ILC2) were initially described in the gut but they are also abundant in lungs and mucosa. They have been shown to produce large quantities of Th2 cytokines after activation with IL-25 and IL-33, playing an important role in virus-induced BHR and allergic asthma.<sup>5,118</sup> ILC2s require the transcription factors ROR $\alpha$  and GATA3 for their development and mainly produce IL-5, IL-9 and IL-13 after activation. Different studies demonstrated that ILC2s play an important role in BHR induction after influenza virus infection through a process depending on IL-33 produced by activated alveolar macrophages.<sup>118,160</sup> In addition, other studies have demonstrated in mice a role for ILC2 in the pathophysiology of asthma and allergic inflammation.<sup>118,161</sup> These data could help to explain virus-induced and allergen-induced BHR and asthma through a common pathway to generate Th2 responses.

## Airway Remodeling in Asthma

Asthmatic airways are characterized by structural airway changes known as airway remodeling, including smooth muscle hypertrophy, goblet cell hyperplasia, subepithelial fibrosis and angiogenesis. Epithelial and mesenchymal cells are in close

contact, forming a truly epithelial-mesenchymal unit that coordinates the initiation of proper responses to injury in the lung. This unit coordinates growth and the response to damage after injury from the environment, potential alterations of which are related to the development of asthma.<sup>162</sup> For this important role, they use cytokines and growth factors such as TGF- $\beta$ , epithelial growth factor (EGF) and VEGF. One of the main features associated with persistent asthma is structural remodeling due to the conversion of mesenchymal cells into myofibroblasts, producing large amounts of interstitial collagens and leading to fibrosis and thickening of the subepithelial basement membrane (lamina reticularis).<sup>163</sup> TGF- $\beta$  produced by resident tissue induces the synthesis of collagen I and inhibits collagenase production in an autocrine manner, thus contributing particularly to airway remodeling and fibrosis in the pathogenesis of asthma.<sup>164,165</sup> TGF- $\beta$  also plays an important role in the control of airway inflammation and restoration of healthy immune responses to allergens.<sup>164</sup> Other alterations observed in the airway include thickening of the bronchial wall, mucus hypersecretion, hyperplasia and hypertrophy of the smooth muscle layer, and neovascularization.<sup>5</sup> Genetic polymorphisms in asthma susceptibility have been described for several genes including *ADAM33* and *filaggrin (FLG)* genes.<sup>163,166</sup>

## The Role of Cell Trafficking and Migration in Pulmonary Inflammation

The homing of the inflammatory cells to the lung is a key aspect in the development of asthma and lung inflammation. Cell trafficking to the lung in asthma is a very complex and redundant process that involves different cytokines, chemokines, adhesion molecules and matrix metalloproteinases (MMPs).

During allergic inflammation, several cells in the lung rapidly produce the chemokines MCP-1/CCL2, MCP-2/CCL8 and eotaxin/CCL11, and basophils expressing the chemokine receptors CCR2, 3 and 4 are the first cells to be recruited. Patients with allergic asthma have significantly higher expression levels of CCR3 and eotaxin/CCL11.<sup>167</sup> The chemokines MCP-3/CCL7, MCP-4/CCL13 and VCAM-1 and MadCAM-1 also direct the recruitment of eosinophils expressing CCR3, CXCR4 and  $\alpha 4\beta 1$ /VLA-4 and  $\alpha 4\beta 7$ /LPAM-1 integrins into the lung.<sup>168</sup> Once inflammatory cells are recruited to the lung, migration into the tissues requires firm adhesion. Extravasation/diapedesis is a complex process that is also regulated by different integrins, chemokines and cytokines through the regulation of the expression of proteinases such as MMPs and matrix-degrading enzymes that allow the leukocytes to penetrate through the basement membrane and into the tissue stroma. In a mouse model of asthma, the expression of MMP2 and MMP9 is significantly increased in BAL fluid after allergen challenge.<sup>169</sup> Supporting these data, inhibition of MMP2 with TIMP-2 impaired the egression of eosinophils from the lungs into the airway lumen and the MMP2-deficient mouse model died of asphyxia after allergen challenge due to severe airway inflammation.<sup>170</sup>

## Epithelial Cell Activation and Barrier Function in Asthma

The epithelial barrier function of bronchial epithelial cells in the asthmatic lung, sinus epithelial cells in the sinus tissue of

chronic rhinosinusitis patients as well as keratinocytes in the skin of atopic dermatitis patients have been demonstrated to be defective.<sup>171–174</sup> These recent studies suggest that tissue integrity is disturbed in patients so that allergens, bacterial toxins and other particles are able to penetrate the epidermis and the lung epithelium, where they may activate the immune system and lead to severe chronic inflammation in both diseases. Epithelial tight junctions (TJs) are responsible for the regulation of paracellular flux and epithelial impermeability. TJs consist of different transmembrane and scaffold adapter proteins and form the most apical intercellular junction essential for barrier function between epithelial cells.<sup>175</sup> In addition, they prevent foreign particles, such as allergens, from entering into the subepithelial layers. In contrast, opening of TJs can lead to drainage of inflammatory cells toward the lumen, supporting the resolution of pathologic processes. Consequently, they can be considered as gatekeepers that could contribute both to aggravation of inflammation-related tissue damage or resolution of inflammation via drainage. It has been shown that TJs are disrupted in airways of patients with asthma as assessed by biopsies, as well as in air-liquid interface epithelial cell cultures from the asthmatic bronchi.<sup>172</sup>

### THE ROLE OF RESPIRATORY VIRUSES IN ASTHMA DEVELOPMENT AND EXACERBATIONS

A large number of epidemiologic studies have shown that asthma exacerbations with acute airway obstruction and wheezing are associated with infections triggered by specific respiratory viruses such as rhinoviruses and, to a lesser extent, respiratory syncytial virus.<sup>1,176</sup> The persistence of respiratory viruses, virus load and virus co-infections have been related to more severe respiratory illnesses. In addition, high rates of respiratory bacterial infections have been associated with asthma exacerbations, indicating that in general respiratory infections may exacerbate rather than prevent the development of asthma. Other studies reported the opposite effect, suggesting that infections might contribute, with different mechanisms during sensitization and effector phases preventing the development of asthma or enhancing symptoms of already existing asthma.

#### Rhinovirus

Rhinovirus, the common cold virus, is the most frequent type of viral infection associated with asthma exacerbations. The detailed underlying immunologic mechanisms are not completely known, but infection of epithelial and bronchial endothelial cells with rhinovirus generates a plethora of proinflammatory mediators that contribute to the worsening of asthma episodes.<sup>1,2</sup> At the T cell level, human rhinovirus infections might contribute to the generation of Th2 cells and inhibit Th1 or IL-10-producing T<sub>REG</sub> cells.<sup>177</sup> Additionally, virus-specific CD8<sup>+</sup> cells producing type 2 cytokines may develop during viral infections.<sup>178</sup> Rhinovirus infections in atopic asthmatic patients lead to more severe and prolonged lower respiratory tract symptoms compared to nonatopic subjects. Clinical trials showed that this might be due to impaired innate and adaptive immune responses in the airways of asthmatic patients.

#### Respiratory Syncytial Virus

Respiratory syncytial virus (RSV) is the most common viral infection during the first 3 years of life, leading to acute viral

bronchiolitis associated with the subsequent development of recurrent wheezing.<sup>179</sup> In addition, allergic asthma increases the risk of RSV infection of the lower respiratory tract and hospitalization, and early wheezing is also a strong risk factor for subsequent RSV hospitalization.<sup>180</sup> RSV infection impairs the capacity of epithelial cells to induce T<sub>REG</sub> cells that are able to suppress undesired adaptive immune responses in the respiratory mucosa, and consequently effector T cells are activated leading to airway inflammation.<sup>181</sup> RSV is also able to promote airway remodeling, which in turn increases the susceptibility of the lung epithelium to initiate allergic responses to inhaled allergens.<sup>182</sup> Treatment of children hospitalized with RSV bronchiolitis with the antiviral ribavirin decreased the risk of subsequent allergic sensitization and development of asthma.<sup>183</sup> In the same way, treatment with palivizumab, a monoclonal antibody preventing RSV infection, of premature infants also reduced subsequent recurrent wheezing.<sup>184</sup>

### The Hygiene Hypothesis

As a consequence of excessive hygiene, the production of IL-10 and TGF- $\beta$  by epithelial cells, DCs and B cells in the mucosa is impaired, inhibiting T<sub>REG</sub> cell activity and increasing Th1 and Th2 cell responses, which accounts for the observed increase in prevalence not only of Th2-mediated allergic diseases but also of Th1-mediated autoimmune disorders.<sup>185,186</sup> Different microorganisms may promote tolerogenic local environments at the mucosal surfaces, diminishing inflammation. A dearth of such specific microorganisms due to the lifestyle of westernized societies might contribute to altered homeostasis and lead to inflammation of the mucosal surfaces. These changes impair the functional features of antigen-specific T<sub>REG</sub> cells to suppress effector T cell response against normally innocuous antigens, thus enhancing Th2 and Th1 pathologic immune responses and leading to allergic and autoimmune diseases.<sup>64</sup>

### ROLE OF BACTERIAL ENDOTOXINS

In contrast to respiratory viral infection, recent studies indicate that early gastrointestinal exposure to Gram-positive commensal bacteria, *Bifidobacterium* and *Lactobacillus* strains, and their derived products, promotes the maturation of the immune system and may protect against the development of asthma.<sup>64,187,188</sup> The exact mechanisms involved in such effects are starting to be deciphered in detail and the activation of TLRs on innate immune system cells such as DCs seems to be of great importance. Different epidemiologic studies on farm environments showed that bacterial lipopolysaccharide exposure and subsequent activation of TLR4-signaling constitute a key mechanism to inhibit the development of Th2-biased immune responses, explaining the observed protective effects against asthma development in such situations.<sup>189</sup> The contribution of other TLRs and PRRs to such effects is an exciting area of research that needs to be further explored.<sup>164,190</sup>

### Asthma Treatment and Induction of Immune Tolerance for Protective Immunity?

Most available treatments for asthma are effective at controlling symptoms; only conventional immunotherapy attempts to

modify the course of the disease. Inhaled corticosteroids are still the mainstay for the treatment of asthma, but limited adherence is a major drawback to the success of such therapy. Allergen-specific immunotherapy (AIT) consists of the administration of increasing doses of the causative allergen to induce a state of immune tolerance.<sup>191</sup> Conventional subcutaneous immunotherapy (SCIT) has been shown to be efficient in controlling established disease. However it carries the problems of severe side-effects and long duration, leading to low patient adherence.<sup>192</sup> Numerous studies in the last two decades have provided a plausible explanation for multiple mechanisms of AIT inducing both rapid desensitization and long-term allergen-specific immune tolerance, and suppression of allergic inflammation in the affected tissues. During AIT, peripheral tolerance is induced by the generation of allergen-specific regulatory T cells, which suppress proliferative and cytokine responses against the allergen of interest. T regulatory cells directly or indirectly suppress effector cells of allergic inflammation, such as mast cells, basophils and eosinophils. T<sub>REG</sub> cells and particularly IL-10 also have an influence on B cells, inhibiting IgE production and inducing the production of blocking type IgG4 antibodies against venom allergens. They also inhibit infiltration of inflammatory cells into tissues, control tissue remodeling and promote tolerogenic DCs (Figure 28-5). These findings together with the new biotechnological approaches create a platform for the development of advanced vaccines. Moreover, reliable biomarkers could be

selected and validated with the intention of selecting the patients who will benefit most from this immune-modifying treatment. Thus, AIT could provide a complete cure for a larger number of allergic patients and novel preventive approaches need to be developed.

Different strategies have been employed to improve the efficacy and safety and reduce treatment time of AIT. For example, coupling of allergens with CpG oligonucleotide motifs (TLR-9 ligand) was shown to inhibit BHR and eosinophil infiltration in a model of asthma and to reduce symptoms in patients with allergic rhinitis.<sup>193</sup> Different therapeutic strategies have been tested or are currently under development including alternative routes of administration such as sublingual (SLIT) or oral (OIT) routes.<sup>191</sup> Novel approaches attempt to generate functional allergen-specific T<sub>REG</sub> cells by manipulating DC function through the administration of different agents, using allergen peptides or by the administration of probiotics such as *Lactobacillus* or *Bifidobacterium*.<sup>108,191</sup> Novel findings demonstrated that the use of biologic agents might also represent an alternative strategy for the treatment of asthma. For example, omalizumab (human anti-IgE mAb) was shown to be effective in the treatment of moderate-to-severe asthma.<sup>194</sup> Other mAbs blocking the function of key Th2 cytokines such as dupilumab (targeting the  $\alpha$  subunit of the IL-4-receptor), lebrikizumab (targeting IL-13) or benralizumab (targeting IL-5 receptor  $\alpha$ ) have been also tested with promising results.<sup>108</sup>

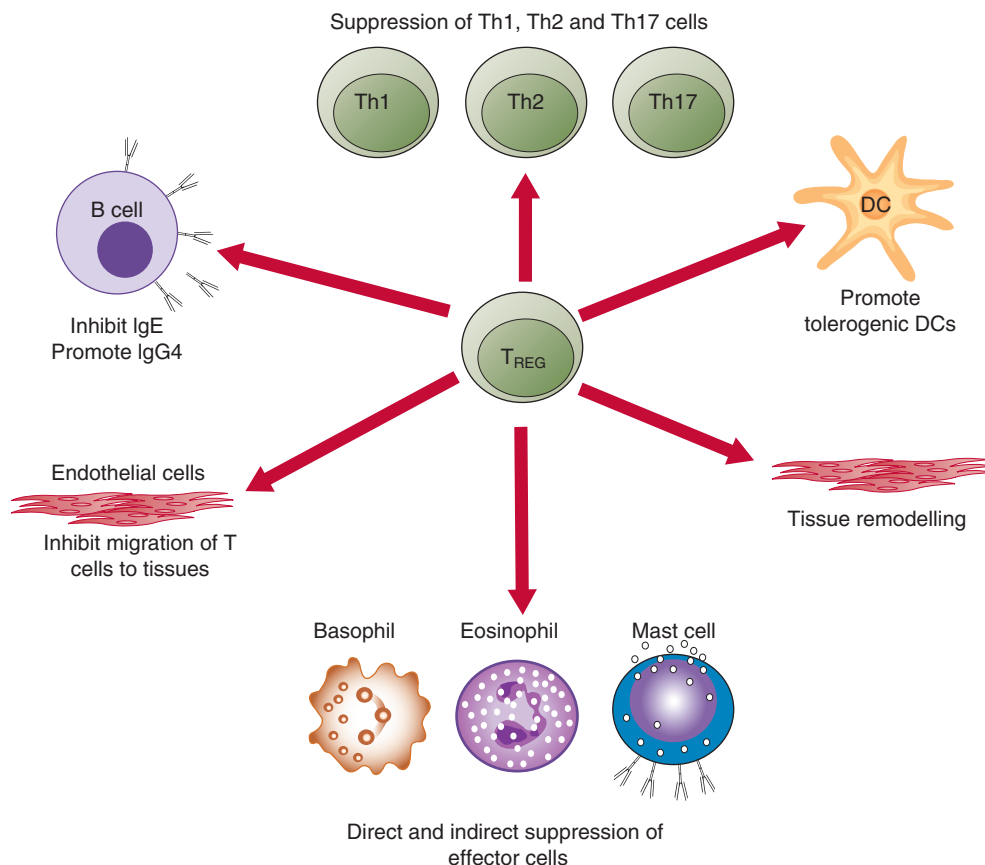

**Figure 28-5** Different mechanisms employed by T<sub>REG</sub> cells to suppress allergic reactions. T<sub>REG</sub> cells directly inhibit Th1, Th2 and Th17 cells and effector cells. They also promote tolerogenic DCs, the induction of IgG4 and inhibition of IgE, inhibition of T cell migration to tissues and tissue remodeling.



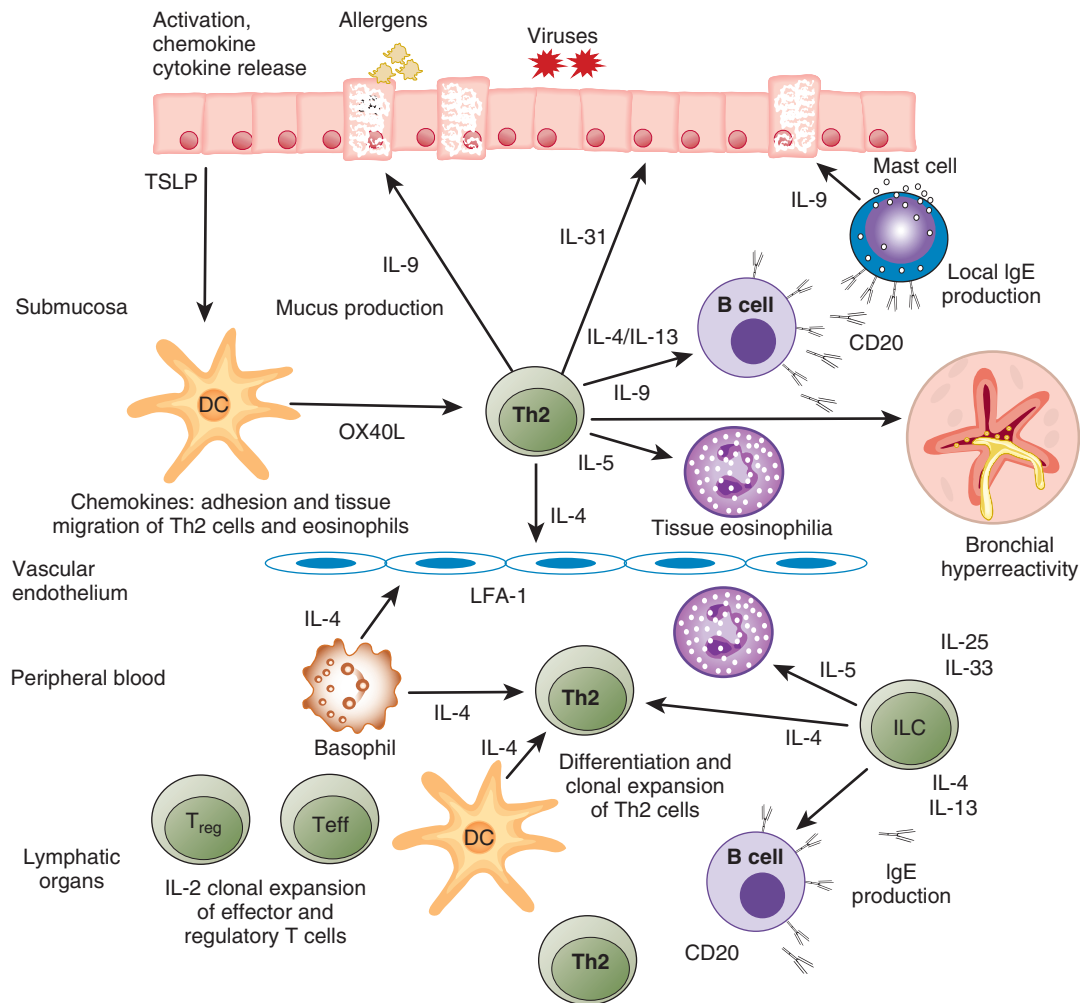

**Figure 28-6** Asthmatic inflammation (effector phase). Epithelial cell activation with production of proinflammatory cytokines and chemokines induces inflammation and contributes to a Th2 response with  $\text{TNF-}\alpha$ , IL-13, TSLP, IL-25, IL-31 and IL-33. Migration of inflammatory cells to asthmatic tissues is regulated by chemokines. Th2 and eosinophil migration are induced by eotaxin, monocyte-derived chemokine (MDC) and activation-regulated chemokine (TARC). Epithelial apoptosis and shedding is observed, mainly mediated by  $\text{IFN-}\gamma$  and  $\text{TNF-}\alpha$ . The adaptive Th2 response includes the production of IL-4, IL-5, IL-9 and IL-13. Innate lymphoid cells, particularly ILC2, also secrete IL-5 and IL-13. Tissue eosinophilia is regulated by IL-5, IL-25 and IL-33. Local and systemic IgE production is observed in bronchial mucosa. Cross-linking of IgE receptor  $\text{Fc}\epsilon\text{R1}$  on the surface of mast cells and basophils and their degranulation take place upon allergen challenge.

## Conclusions

Our knowledge of the mechanisms operating in allergic asthma has increased markedly over the past years, which has significantly contributed to improvements in the diagnosis, management and treatment of the disease (Figure 28-6). Critical mediators involved in the Th2-biased asthmatic immune response and airway remodeling have been identified. Better understanding of the contribution of the innate immune system to the development of asthma, including the recently discovered ILC2, demonstrated that the Th2 cytokine signature might not simply reflect an adaptive Th2 cellular response but the integration of a much more complex network of cells and molecules. Rhinovirus and RSV infections have been associated with asthma exacerbations and, in the same way, asthma has frequently been related to increased susceptibility to infection with rhinoviruses and RSV as well as with changes in the microbiota not only in the airways but also in the intestinal tract. The hygiene hypothesis postulated that lack of microbial exposure and loss of commensal bacteria could explain the

increased prevalence of Th2-biased allergic asthma. The generation of functional allergen-specific  $\text{T}_{\text{REG}}$  cells is a key event in the generation of healthy immune responses to allergens. Compelling experimental evidence demonstrated that  $\text{T}_{\text{REG}}$  cells in cooperation with other cell types such as  $\text{B}_{\text{REG}}$  cells or DCs producing high levels of IL-10 and/or  $\text{TGF-}\beta$  play an essential role in the initiation and maintenance of immune tolerance to allergens. Although initial therapies were based on relieving airway obstruction in asthma, current therapy focuses on reducing airway inflammation and neutralizing the effects of mast cell mediators. Better understanding of the molecular and cellular events implicated in the pathogenesis of the allergic diseases will contribute significantly to the development of better prevention strategies and alternative therapeutic options, including the use of immunotherapy combined with biologics.

The complete reference list can be found on the companion Expert Consult website at <http://www.expertconsult.inking.com>.

## KEY REFERENCES

3. Lotvall J, Akdis CA, Bacharier LB, Bjermer L, Casale TB, Custovic A, et al. Asthma endotypes: a new approach to classification of disease entities within the asthma syndrome. *J Allergy Clin Immunol* 2011;127:355–60.
8. Akdis M, Akdis CA. Mechanisms of allergen-specific immunotherapy: multiple suppressor factors at work in immune tolerance to allergens. *J Allergy Clin Immunol* 2014;133:621–31.
16. Akdis M, Burgler S, Cramer R, Eiwegger T, Fujita H, Gomez E, et al. Interleukins, from 1 to 37, and interferon-gamma: receptors, functions, and roles in diseases. *J Allergy Clin Immunol* 2011;127:701–21, e70.
75. Akdis M, Verhagen J, Taylor A, Karamloo F, Karagiannidis C, Cramer R, et al. Immune responses in healthy and allergic individuals are characterized by a fine balance between allergen-specific T regulatory 1 and T helper 2 cells. *J Exp Med* 2004;199:1567–75.
78. Palomares O, Ruckert B, Jartti T, Kucuksezer UC, Puhakka T, Gomez E, et al. Induction and maintenance of allergen-specific FOXP3+ T<sub>REG</sub> cells in human tonsils as potential first-line organs of oral tolerance. *J Allergy Clin Immunol* 2012;129:510–20, 20 e1–9.
79. Kucuksezer UC, Palomares O, Ruckert B, Jartti T, Puhakka T, Nandy A, et al. Triggering of specific Toll-like receptors and proinflammatory cytokines breaks allergen-specific T-cell tolerance in human tonsils and peripheral blood. *J Allergy Clin Immunol* 2013;131:875–85.
105. van de Veen W, Stanic B, Yaman G, Wawrzyniak M, Sollner S, Akdis DG, et al. IgG4 production is confined to human IL-10-producing regulatory B cells that suppress antigen-specific immune responses. *J Allergy Clin Immunol* 2013;131:1204–12.
118. Yu S, Kim HY, Chang YJ, DeKruyff RH, Umetsu DT. Innate lymphoid cells and asthma. *J Allergy Clin Immunol* 2014;133:943–50, quiz 51.
122. Pushparaj PN, Tay HK, H'Ng SC, Pitman N, Xu D, McKenzie A, et al. The cytokine interleukin-33 mediates anaphylactic shock. *Proc Natl Acad Sci U S A* 2009;106:9773–8.
146. Hammad H, Plantinga M, Deswarte K, Pouliot P, Willart MA, Kool M, et al. Inflammatory dendritic cells – not basophils – are necessary and sufficient for induction of Th2 immunity to inhaled house dust mite allergen. *J Exp Med* 2010;207:2097–111.

## REFERENCES

- Custovic A, Johnston SL, Pavord I, Gaga M, Fabbri L, Bel EH, et al. EAACI position statement on asthma exacerbations and severe asthma. *Allergy* 2013;68:1520–31.
- Apter AJ. Advances in adult asthma diagnosis and treatment in 2012: potential therapeutics and gene-environment interactions. *J Allergy Clin Immunol* 2013;131:47–54.
- Lotvall J, Akdis CA, Bacharier LB, Bjermer L, Casale TB, Custovic A, et al. Asthma endotypes: a new approach to classification of disease entities within the asthma syndrome. *J Allergy Clin Immunol* 2011;127:355–60.
- Holt PG, Macaubas C, Stumbles PA, Sly PD. The role of allergy in the development of asthma. *Nature* 1999;402:B12–17.
- Martinez FD, Vercelli D. Asthma. *Lancet* 2013;382:1360–72.
- O'Hollaren MT, Yunginger JW, Offord KP, Somers MJ, O'Connell EJ, Ballard DJ, et al. Exposure to an aeroallergen as a possible precipitating factor in respiratory arrest in young patients with asthma. *N Engl J Med* 1991;324:359–63.
- Sears MR, Burrows B, Flannery EM, Herbison GP, Hewitt CJ, Holdaway MD. Relation between airway responsiveness and serum IgE in children with asthma and in apparently normal children. *N Engl J Med* 1991;325:1067–71.
- Akdis M, Akdis CA. Mechanisms of allergen-specific immunotherapy: multiple suppressor factors at work in immune tolerance to allergens. *J Allergy Clin Immunol* 2014;133:621–31.
- Larche M, Akdis CA, Valenta R. Immunological mechanisms of allergen-specific immunotherapy. *Nat Rev Immunol* 2006;6:761–71.
- Akdis CA, Akdis M. Mechanisms and treatment of allergic disease in the big picture of regulatory T cells. *J Allergy Clin Immunol* 2009;123:735–46, quiz 47–8.
- Akdis M, Akdis CA. Therapeutic manipulation of immune tolerance in allergic disease. *Nat Rev Drug Discov* 2009;8:645–60.
- Dillon SR, Sprecher C, Hammond A, Bilsborough J, Rosenfeld-Franklin M, Presnell SR, et al. Interleukin 31, a cytokine produced by activated T cells, induces dermatitis in mice. *Nat Immunol* 2004;5:752–60.
- Kakkar R, Lee RT. The IL-33/ST2 pathway: therapeutic target and novel biomarker. *Nat Rev Drug Discov* 2008;7:827–40.
- Wang YH, Angkasekwinai P, Lu N, Voo KS, Arima K, Hanabuchi S, et al. IL-25 augments type 2 immune responses by enhancing the expansion and functions of TSLP-DC-activated Th2 memory cells. *J Exp Med* 2007;204:1837–47.
- Paul WE, Zhu J. How are T(H)2-type immune responses initiated and amplified? *Nat Rev Immunol* 2010;10:225–35.
- Akdis M, Burgler S, Cramer R, Eiwegger T, Fujita H, Gomez E, et al. Interleukins, from 1 to 37, and interferon-gamma: receptors, functions, and roles in diseases. *J Allergy Clin Immunol* 2011;127:701–21, e70.
- Seder RA, Paul WE, Davis MM, Fazekas de St Groth B. The presence of interleukin 4 during in vitro priming determines the lymphokine-producing potential of CD4+ T cells from T cell receptor transgenic mice. *J Exp Med* 1992;176:1091–8.
- Hsieh CS, Heimberger AB, Gold JS, O'Garra A, Murphy KM. Differential regulation of T helper phenotype development by interleukins 4 and 10 in an alpha beta T-cell-receptor transgenic system. *Proc Natl Acad Sci U S A* 1992;89:6065–9.
- Hsieh FH, Lam BK, Penrose JF, Austen KF, Boyce JA. T helper cell type 2 cytokines coordinately regulate immunoglobulin E-dependent cysteinyl leukotriene production by human cord blood-derived mast cells: profound induction of leukotriene C(4) synthase expression by interleukin 4. *J Exp Med* 2001;193:123–33.
- Kuhn R, Rajewsky K, Muller W. Generation and analysis of interleukin-4 deficient mice. *Science* 1991;254:707–10.
- Kuraoka M, Hashiguchi M, Hachimura S, Kaminogawa S. CD4(-)c-kit(-)CD3epsilon(-)IL-2Ralpha(+) Peyer's patch cells are a novel cell subset which secrete IL-5 in response to IL-2: implications for their role in IgA production. *Eur J Immunol* 2004;34:1920–9.
- Bousquet J, Chanez P, Lacoste JY, Barneon G, Ghavanian N, Enander I, et al. Eosinophilic inflammation in asthma. *N Engl J Med* 1990;323:1033–9.
- Kinoshita T, Yokota T, Arai K, Miyajima A. Regulation of Bcl-2 expression by oncogenic Ras protein in hematopoietic cells. *Oncogene* 1995;10:2207–12.
- Kinoshita T, Yokota T, Arai K, Miyajima A. Suppression of apoptotic death in hematopoietic cells by signalling through the IL-3/GM-CSF receptors. *EMBO J* 1995;14:266–75.
- Walsh GM, Wardlaw AJ, Hartnell A, Sanderson CJ, Kay AB. Interleukin-5 enhances the in vitro adhesion of human eosinophils, but not neutrophils, in a leucocyte integrin (CD11/18)-dependent manner. *Int Arch Allergy Appl Immunol* 1991;94:174–8.
- Yang M, Hogan SP, Mahalingam S, Pope SM, Zimmermann N, Fulkerson P, et al. Eotaxin-2 and IL-5 cooperate in the lung to regulate IL-13 production and airway eosinophilia and hyperreactivity. *J Allergy Clin Immunol* 2003;112:935–43.
- Flood-Page B, Menzies-Gow A, Phipps S, Ying S, Wangoo A, Ludwig MS, et al. Anti-IL-5 treatment reduces deposition of ECM proteins in the bronchial subepithelial basement membrane of mild atopic asthmatics. *J Clin Invest* 2003;112:1029–36.
- Hamid Q, Azzawi M, Ying S, Moqbel R, Wardlaw AJ, Corrigan CJ, et al. Expression of mRNA for interleukin-5 in mucosal bronchial biopsies from asthma. *J Clin Invest* 1991;87:1541–6.
- Mattes J, Yang M, Mahalingam S, Kuehr J, Webb DC, Simson L, et al. Intrinsic defect in T cell production of interleukin (IL)-13 in the absence of both IL-5 and eotaxin precludes the development of eosinophilia and airways hyperreactivity in experimental asthma. *J Exp Med* 2002;195:1433–44.
- Foster PS, Hogan SP, Ramsay AJ, Matthaei KI, Young IG. Interleukin 5 deficiency abolishes eosinophilia, airways hyperreactivity, and lung damage in a mouse asthma model. *J Exp Med* 1996;183:195–201.
- Leckie MJ, ten Brinke A, Khan J, Diamant Z, O'Connor BJ, Walls CM, et al. Effects of an interleukin-5 blocking monoclonal antibody on eosinophils, airway hyper-responsiveness, and the late asthmatic response. *Lancet* 2000;356:2144–8.
- Flood-Page P, Swenson C, Faiferman I, Matthews J, Williams M, Brannick L, et al. A study to evaluate safety and efficacy of mepolizumab in patients with moderate persistent asthma. *Am J Respir Crit Care Med* 2007;176:1062–71.
- Kips JC, O'Connor BJ, Langley SJ, Woodcock A, Kerstjens HA, Postma DS, et al. Effect of SCH55700, a humanized anti-human interleukin-5 antibody, in severe persistent asthma: a pilot study. *Am J Respir Crit Care Med* 2003;167:1655–9.
- Haldar P, Brightling CE, Hargadon B, Gupta S, Monteiro W, Sousa A, et al. Mepolizumab and exacerbations of refractory eosinophilic asthma. *N Engl J Med* 2009;360:973–84.
- Nair P, Pizzichini MM, Kjarsgaard M, Inman MD, Efthimiadis A, Pizzichini E, et al. Mepolizumab for prednisone-dependent asthma with sputum eosinophilia. *N Engl J Med* 2009;360:985–93.
- Wynn TA. IL-13 effector functions. *Annu Rev Immunol* 2003;21:425–56.
- Chiaromonte MG, Cheever AW, Malley JD, Donaldson DD, Wynn TA. Studies of murine schistosomiasis reveal interleukin-13 blockade as a treatment for established and progressive liver fibrosis. *Hepatology* 2001;34:273–82.
- Chiaromonte MG, Schopf LR, Neben TY, Cheever AW, Donaldson DD, Wynn TA. IL-13 is a key regulatory cytokine for Th2 cell-mediated pulmonary granuloma formation and IgE responses induced by *Schistosoma mansoni* eggs. *J Immunol* 1999;162:920–30.
- Hunninghake GM, Soto-Quiros ME, Avila L, Su J, Murphy A, Demeo DL, et al. Polymorphisms in IL13, total IgE, eosinophilia, and asthma exacerbations in childhood. *J Allergy Clin Immunol* 2007;120:84–90.
- McKenzie GJ, Bancroft A, Grecnis RK, McKenzie AN. A distinct role for interleukin-13 in Th2-cell-mediated immune responses. *Curr Biol* 1998;8:339–42.
- McKenzie GJ, Emson CL, Bell SE, Anderson S, Fallon P, Zurawski G, et al. Impaired development of Th2 cells in IL-13-deficient mice. *Immunity* 1998;9:423–32.
- Zhu Z, Homer RJ, Wang Z, Chen Q, Geba GP, Wang J, et al. Pulmonary expression of interleukin-13 causes inflammation, mucus hypersecretion, subepithelial fibrosis, physiologic abnormalities, and eotaxin production. *J Clin Invest* 1999;103:779–88.
- Wenzel S, Wilbraham D, Fuller R, Getz EB, Longphre M. Effect of an interleukin-4 variant on late phase asthmatic response to allergen challenge in asthmatic patients: results of two phase 2a studies. *Lancet* 2007;370:1422–31.
- Lowenthal JW, Castle BE, Christiansen J, Schreurs J, Rennick D, Arai N, et al. Expression of high affinity receptors for murine interleukin 4 (BSF-1) on hemopoietic and nonhemopoietic cells. *J Immunol* 1988;140:456–64.
- Nelms K, Keegan AD, Zamorano J, Ryan JJ, Paul WE. The IL-4 receptor: signaling mechanisms and biologic functions. *Annu Rev Immunol* 1999;17:701–38.
- Mantel PY, Kuipers H, Boyman O, Rhyner C, Ouaked N, Ruckert B, et al. GATA3-driven Th2 responses inhibit TGF-beta 1-induced FOXP3

- expression and the formation of regulatory T cells. *PLoS Biol* 2007;5:2847–61.
47. Mullings RE, Wilson SJ, Puddicombe SM, Lordan JL, Bucchieri F, Djukanovic R, et al. Signal transducer and activator of transcription 6 (STAT-6) expression and function in asthmatic bronchial epithelium. *J Allergy Clin Immunol* 2001;108:832–8.
  48. Nakamura Y, Ghaffar O, Olivenstein R, Taha RA, Soussi-Gounni A, Zhang DH, et al. Gene expression of the GATA-3 transcription factor is increased in atopic asthma. *J Allergy Clin Immunol* 1999;103:215–22.
  49. Mosmann TR, Cherwinski H, Bond MW, Giedlin MA, Coffman RL. Two types of murine helper T cell clones. I. Definition according to profiles of lymphokine activities and secreted proteins. *J Immunol* 1986;136:2348–57.
  50. Katamura K, Tabata Y, Oshima Y, Shintaku N, Yamauchi Y, Mayumi M. Selective induction of interleukin-4- and interferon- $\gamma$ -producing T cells from cord blood naive T cells. Effects of costimulatory signaling through CD28. *Int Arch Allergy Immunol* 1995;106:101–6.
  51. Finotto S, Neurath MF, Glickman JN, Qin S, Lehr HA, Green FH, et al. Development of spontaneous airway changes consistent with human asthma in mice lacking T-bet. *Science* 2002;295:336–8.
  52. Tang LL, Benjaponpitak S, DeKruyff RH, Umetsu DT. Reduced prevalence of allergic disease in patients with multiple sclerosis is associated with enhanced IL-12 production. *J Allergy Clin Immunol* 1998;102:428–35.
  53. Rogge L, Papi A, Presky DH, Biffi M, Minetti LJ, Miotto D, et al. Antibodies to the IL-12 receptor beta 2 chain mark human Th1 but not Th2 cells in vitro and in vivo. *J Immunol* 1999;162:3926–32.
  54. Trautmann A, Akdis M, Kleemann D, Altnauer F, Simon HU, Graeve T, et al. T cell-mediated Fas-induced keratinocyte apoptosis plays a key pathogenetic role in eczematous dermatitis. *J Clin Invest* 2000;106:25–35.
  55. Basinski TM, Holzmann D, Eiwegger T, Zimmermann M, Klunker S, Meyer N, et al. Dual nature of T cell-epithelium interaction in chronic rhinosinusitis. *J Allergy Clin Immunol* 2009;124:74–80, e1–8.
  56. Hellings PW, Kasran A, Liu Z, Vandekerckhove P, Wuyts A, Overbergh L, et al. Interleukin-17 orchestrates the granulocyte influx into airways after allergen inhalation in a mouse model of allergic asthma. *Am J Respir Cell Mol Biol* 2003;28:42–50.
  57. Veldhoen M, Uyttenhove C, van Snick J, Helms H, Westendorp A, Buer J, et al. Transforming growth factor- $\beta$  'reprograms' the differentiation of T helper 2 cells and promotes an interleukin 9-producing subset. *Nat Immunol* 2008;9:1341–6.
  58. Nograles KE, Zaba LC, Shemer A, Fuentes-Duculan J, Cardinale I, Kikuchi T, et al. IL-22-producing 'T22' T cells account for upregulated IL-22 in atopic dermatitis despite reduced IL-17-producing TH17 T cells. *J Allergy Clin Immunol* 2009;123:1244–52, e2.
  59. Eyerich S, Eyerich K, Pennino D, Carbone T, Nasorri F, Pallotta S, et al. Th22 cells represent a distinct human T cell subset involved in epidermal immunity and remodeling. *J Clin Invest* 2009;119:3573–85.
  60. Anderson GP. Endotyping asthma: new insights into key pathogenic mechanisms in a complex, heterogeneous disease. *Lancet* 2008;372:1107–19.
  61. Akdis CA, Akdis M. Mechanisms of allergen-specific immunotherapy. *J Allergy Clin Immunol* 2011;127:18–27, quiz 8–9.
  62. Boden E, Tang Q, Bour-Jordan H, Bluestone JA. The role of CD28 and CTLA4 in the function and homeostasis of CD4+CD25+ regulatory T cells. *Novartis Found Symp* 2003;252:55–63, discussion 63–6, 106–14.
  63. Carter L, Fouser LA, Jussif J, Fitz L, Deng B, Wood CR, et al. PD-1:PD-L inhibitory pathway affects both CD4(+) and CD8(+) T cells and is overcome by IL-2. *Eur J Immunol* 2002;32:634–43.
  64. Palomares O, Yaman G, Azkur AK, Akkoc T, Akdis M, Akdis CA. Role of T<sub>REG</sub> in immune regulation of allergic diseases. *Eur J Immunol* 2010;40:1232–40.
  65. Hori S, Nomura T, Sakaguchi S. Control of regulatory T cell development by the transcription factor Foxp3. *Science* 2003;299:1057–61.
  66. Fontenot JD, Gavin MA, Rudensky AY. Foxp3 programs the development and function of CD4+CD25+ regulatory T cells. *Nat Immunol* 2003;4:330–6.
  67. Sakaguchi S, Vignali DA, Rudensky AY, Niec RE, Waldmann H. The plasticity and stability of regulatory T cells. *Nat Rev Immunol* 2013;13:461–7.
  68. McMurchy AN, Gillies J, Allan SE, Passerini L, Gambineri E, Roncarolo MG, et al. Point mutants of forkhead box P3 that cause immune dysregulation, polyendocrinopathy, enteropathy, X-linked have diverse abilities to reprogram T cells into regulatory T cells. *J Allergy Clin Immunol* 2010;126:1242–51.
  69. Chatila TA, Blaeser F, Ho N, Lederman HM, Voulgaropoulos C, Helms C, et al. JM2, encoding a fork head-related protein, is mutated in X-linked autoimmunity-allergic dysregulation syndrome. *J Clin Invest* 2000;106:R75–81.
  70. Lin W, Truong N, Grossman WJ, Haribhai D, Williams CB, Wang J, et al. Allergic dysregulation and hyperimmunoglobulinemia E in Foxp3 mutant mice. *J Allergy Clin Immunol* 2005;116:1106–15.
  71. Meiler F, Zumkehr J, Klunker S, Ruckert B, Akdis CA, Akdis M. In vivo switch to IL-10-secreting T regulatory cells in high dose allergen exposure. *J Exp Med* 2008;205:2887–98.
  72. Gregori S, Magnani CF, Roncarolo MG. Role of human leukocyte antigen-G in the induction of adaptive type 1 regulatory T cells. *Hum Immunol* 2009;70:966–9.
  73. Xystrakis E, Kusumakar S, Boswell S, Peek E, Urry Z, Richards DF, et al. Reversing the defective induction of IL-10-secreting regulatory T cells in glucocorticoid-resistant asthma patients. *J Clin Invest* 2006;116:146–55.
  74. Akdis M. Healthy immune response to allergens: T regulatory cells and more. *Curr Opin Immunol* 2006;18:738–44.
  75. Akdis M, Verhagen J, Taylor A, Karamloo F, Karagiannidis C, Cramer R, et al. Immune responses in healthy and allergic individuals are characterized by a fine balance between allergen-specific T regulatory 1 and T helper 2 cells. *J Exp Med* 2004;199:1567–75.
  76. Carballido JM, Carballido-Perrig N, Kagi MK, Meloen RH, Wuthrich B, Heusser CH, et al. T cell epitope specificity in human allergic and nonallergic subjects to bee venom phospholipase A2. *J Immunol* 1993;150:3582–91.
  77. Platts-Mills T, Vaughan J, Squillace S, Woodfolk J, Sporik R. Sensitisation, asthma, and a modified Th2 response in children exposed to cat allergen: a population-based cross-sectional study. *Lancet* 2001;357:752–6.
  78. Palomares O, Ruckert B, Jartti T, Kucuksezer UC, Puhakka T, Gomez E, et al. Induction and maintenance of allergen-specific FOXP3+ T<sub>REG</sub> cells in human tonsils as potential first-line organs of oral tolerance. *J Allergy Clin Immunol* 2012;129:510–20, 520.e1–9.
  79. Kucuksezer UC, Palomares O, Ruckert B, Jartti T, Puhakka T, Nandy A, et al. Triggering of specific Toll-like receptors and proinflammatory cytokines breaks allergen-specific T-cell tolerance in human tonsils and peripheral blood. *J Allergy Clin Immunol* 2013;131:875–85.
  80. Conti HR, Shen F, Nayyar N, Stocum E, Sun JN, Lindemann MJ, et al. Th17 cells and IL-17 receptor signaling are essential for mucosal host defense against oral candidiasis. *J Exp Med* 2009;206:299–311.
  81. Dunne A, Ross PJ, Pospisilova E, Masin J, Meaney A, Sutton CE, et al. Inflammasome activation by adenylate cyclase toxin directs Th17 responses and protection against *Bordetella pertussis*. *J Immunol* 2010;185:1711–19.
  82. Akdis M, Palomares O, van de Veen W, van Splunter M, Akdis CA. TH17 and TH22 cells: a confusion of antimicrobial response with tissue inflammation versus protection. *J Allergy Clin Immunol* 2012;129:1438–49, quiz 50–1.
  83. Akdis M, Burgler S, Cramer R, Eiwegger T, Fujita H, Gomez E, et al. Interleukins, from 1 to 37, and interferon- $\gamma$ : receptors, functions, and roles in diseases. *J Allergy Clin Immunol* 2011;127:701–2, e1–70.
  84. Harrington LE, Hatton RD, Mangan PR, Turner H, Murphy TL, Murphy KM, et al. Interleukin 17-producing CD4+ effector T cells develop via a lineage distinct from the T helper type 1 and 2 lineages. *Nat Immunol* 2005;6:1123–32.
  85. Zheng Y, Danilenko DM, Valdez P, Kasman I, Eastham-Anderson J, Wu J, et al. Interleukin-22, a T(H)17 cytokine, mediates IL-23-induced dermal inflammation and acanthosis. *Nature* 2007;445:648–51.
  86. Burgler S, Ouaked N, Bassin C, Basinski TM, Mantel PY, Siegmund K, et al. Differentiation and functional analysis of human T(H)17 cells. *J Allergy Clin Immunol* 2009;123:588–95.
  87. Peters A, Lee Y, Kuchroo VK. The many faces of Th17 cells. *Curr Opin Immunol* 2011;23:702–6.
  88. Schmidt-Weber CB, Akdis M, Akdis CA. TH17 cells in the big picture of immunology. *J Allergy Clin Immunol* 2007;120:247–54.
  89. Nakae S, Saijo S, Horai R, Sudo K, Mori S, Iwakura Y. IL-17 production from activated T cells is required for the spontaneous development of destructive arthritis in mice deficient in IL-1 receptor antagonist. *Proc Natl Acad Sci U S A* 2003;100:5986–90.
  90. Sergejeva S, Ivanov S, Lotvall J, Linden A. Interleukin-17 as a recruitment and survival factor for airway macrophages in allergic airway inflammation. *Am J Respir Cell Mol Biol* 2005;33:248–53.
  91. Wilson RH, Whitehead GS, Nakano H, Free ME, Kolls JK, Cook DN. Allergic sensitization through the airway primes Th17-dependent neutrophilia and airway hyperresponsiveness. *Am J Respir Crit Care Med* 2009;180:720–30.
  92. Chang Y, Al-Alwan L, Risse PA, Roussel L, Rousseau S, Halayko AJ, et al. TH17 cytokines induce human airway smooth muscle cell



- migration. *J Allergy Clin Immunol* 2011;127:1046–53, e1–2.
93. Lluis A, Schedel M, Liu J, Illi S, Depner M, von Mutius E, et al. Asthma-associated polymorphisms in 17q21 influence cord blood ORMDL3 and GSDMA gene expression and IL-17 secretion. *J Allergy Clin Immunol* 2011;127:1587–94, e6.
  94. Temann UA, Geba GP, Rankin JA, Flavell RA. Expression of interleukin 9 in the lungs of transgenic mice causes airway inflammation, mast cell hyperplasia, and bronchial hyperresponsiveness. *J Exp Med* 1998;188:1307–20.
  95. Temann UA, Ray P, Flavell RA. Pulmonary overexpression of IL-9 induces Th2 cytokine expression, leading to immune pathology. *J Clin Invest* 2002;109:29–39.
  96. McLane MP, Haczk A, van de Rijn M, Weiss C, Ferrante V, MacDonald D, et al. Interleukin-9 promotes allergen-induced eosinophilic inflammation and airway hyperresponsiveness in transgenic mice. *Am J Respir Cell Mol Biol* 1998;19:713–20.
  97. Vink A, Warnier G, Brombacher F, Renauld JC. Interleukin 9-induced in vivo expansion of the B-1 lymphocyte population. *J Exp Med* 1999;189:1413–23.
  98. Dugas B, Renauld JC, Pene J, Bonnefoy JY, Pети-Frere C, Braquet P, et al. Interleukin-9 potentiates the interleukin-4-induced immunoglobulin (IgG, IgM and IgE) production by normal human B lymphocytes. *Eur J Immunol* 1993;23:1687–92.
  99. Shimbara A, Christodoulouopoulos P, Soussi-Gounni A, Olivenstein R, Nakamura Y, Levitt RC, et al. IL-9 and its receptor in allergic and nonallergic lung disease: increased expression in asthma. *J Allergy Clin Immunol* 2000;105:108–15.
  100. Liang SC, Tan XY, Luxenberg DP, Karim R, Dunussi-Joannopoulos K, Collins M, et al. Interleukin (IL)-22 and IL-17 are coexpressed by Th17 cells and cooperatively enhance expression of antimicrobial peptides. *J Exp Med* 2006;203:2271–9.
  101. Chung Y, Yang X, Chang SH, Ma L, Tian Q, Dong C. Expression and regulation of IL-22 in the IL-17-producing CD4<sup>+</sup> T lymphocytes. *Cell Res* 2006;16:902–7.
  102. Wolk K, Kunz S, Asadullah K, Sabat R. Cutting edge: immune cells as sources and targets of the IL-10 family members? *J Immunol* 2002;168:5397–402.
  103. McKinley L, Alcorn JF, Peterson A, Dupont RB, Kapadia S, Logar A, et al. TH17 cells mediate steroid-resistant airway inflammation and airway hyperresponsiveness in mice. *J Immunol* 2008;181:4089–97.
  104. Takahashi K, Hirose K, Kawashima S, Niwa Y, Wakashin H, Iwata A, et al. IL-22 attenuates IL-25 production by lung epithelial cells and inhibits antigen-induced eosinophilic airway inflammation. *J Allergy Clin Immunol* 2011;128:1067–76, e1–6.
  105. van de Veen W, Stanic B, Yaman G, Wawrzyniak M, Sollner S, Akdis DG, et al. IgG4 production is confined to human IL-10-producing regulatory B cells that suppress antigen-specific immune responses. *J Allergy Clin Immunol* 2013;131:1204–12.
  106. Stanic B, van de Veen W, Wirz OF, Ruckert B, Morita H, Sollner S, et al. IL-10-overexpressing B cells regulate innate and adaptive immune responses. *J Allergy Clin Immunol* 2015;135:771–80.
  107. Zhang N, Truong-Tran QA, Tancowny B, Harris KE, Schleimer RP. Glucocorticoids enhance or spare innate immunity: effects in airway epithelium are mediated by CCAAT/enhancer binding proteins. *J Immunol* 2007;179:578–89.
  108. Akdis CA. Therapies for allergic inflammation: refining strategies to induce tolerance. *Nat Med* 2012;18:736–49.
  109. Kang MJ, Lee CG, Lee JY, Dela Cruz CS, Chen ZJ, Enelow R, et al. Cigarette smoke selectively enhances viral PAMP- and virus-induced pulmonary innate immune and remodeling responses in mice. *J Clin Invest* 2008;118:2771–84.
  110. Gualano RC, Hansen MJ, Vlahos R, Jones JE, Park-Jones RA, Deliyannis G, et al. Cigarette smoke worsens lung inflammation and impairs resolution of influenza infection in mice. *Respir Res* 2008;9:53.
  111. Holgate ST, Lackie P, Wilson S, Roche W, Davies D. Bronchial epithelium as a key regulator of airway allergen sensitization and remodeling in asthma. *Am J Respir Crit Care Med* 2000;162:S113–17.
  112. Fort MM, Cheung J, Yen D, Li J, Zurawski SM, Lo S, et al. IL-25 induces IL-4, IL-5, and IL-13 and Th2-associated pathologies in vivo. *Immunity* 2001;15:985–95.
  113. Ikeda K, Nakajima H, Suzuki K, Kagami S, Hirose K, Suto A, et al. Mast cells produce interleukin-25 upon Fc epsilon RI-mediated activation. *Blood* 2003;101:3594–6.
  114. Angkasekwinai P, Park H, Wang YH, Chang SH, Corry DB, Liu YJ, et al. Interleukin 25 promotes the initiation of proallergic type 2 responses. *J Exp Med* 2007;204:1509–17.
  115. Hammad H, Chieppa M, Perros F, Willart MA, Germain RN, Lambrecht BN. House dust mite allergen induces asthma via Toll-like receptor 4 triggering of airway structural cells. *Nat Med* 2009;15:410–16.
  116. Tamachi T, Maezawa Y, Ikeda K, Kagami S, Hatano M, Seto Y, et al. IL-25 enhances allergic airway inflammation by amplifying a TH2 cell-dependent pathway in mice. *J Allergy Clin Immunol* 2006;118:606–14.
  117. Terashima A, Watarai H, Inoue S, Sekine E, Nakagawa R, Hase K, et al. A novel subset of mouse NKT cells bearing the IL-17 receptor B responds to IL-25 and contributes to airway hyperreactivity. *J Exp Med* 2008;205:2727–33.
  118. Yu S, Kim HY, Chang YJ, DeKruyff RH, Umetsu DT. Innate lymphoid cells and asthma. *J Allergy Clin Immunol* 2014;133:943–50, quiz 51.
  119. Ballantyne SJ, Barlow JL, Jolin HE, Nath P, Williams AS, Chung KF, et al. Blocking IL-25 prevents airway hyperresponsiveness in allergic asthma. *J Allergy Clin Immunol* 2007;120:1324–31.
  120. Schmitz J, Owyang A, Oldham E, Song Y, Murphy E, McClanahan TK, et al. IL-33, an interleukin-1-like cytokine that signals via the IL-1 receptor-related protein ST2 and induces T helper type 2-associated cytokines. *Immunity* 2005;23:479–90.
  121. Cherry WB, Yoon J, Bartemes KR, Iijima K, Kita H. A novel IL-1 family cytokine, IL-33, potently activates human eosinophils. *J Allergy Clin Immunol* 2008;121:1484–90.
  122. Pushparaj PN, Tay HK, H'Ng SC, Pitman N, Xu D, McKenzie A, et al. The cytokine interleukin-33 mediates anaphylactic shock. *Proc Natl Acad Sci U S A* 2009;106:9773–8.
  123. Eiwegger T, Akdis CA. IL-33 links tissue cells, dendritic cells and Th2 cell development in a mouse model of asthma. *Eur J Immunol* 2011;41:1535–8.
  124. Kurowska-Stolarska M, Stolarski B, Kewin P, Murphy G, Corrigan CJ, Ying S, et al. IL-33 amplifies the polarization of alternatively activated macrophages that contribute to airway inflammation. *J Immunol* 2009;183:6469–77.
  125. Baekkevold ES, Roussigne M, Yamanaka T, Johansen FE, Jahnsen FL, Amalric F, et al. Molecular characterization of NF-HEV, a nuclear factor preferentially expressed in human high endothelial venules. *Am J Pathol* 2003;163:69–79.
  126. Carriere V, Roussel L, Ortega N, Lacorre DA, Americh L, Aguilar L, et al. IL-33, the IL-1-like cytokine ligand for ST2 receptor, is a chromatin-associated nuclear factor in vivo. *Proc Natl Acad Sci U S A* 2007;104:282–7.
  127. Ito T, Wang YH, Duramad O, Hori T, Delespesse GJ, Watanabe N, et al. TSLP-activated dendritic cells induce an inflammatory T helper type 2 cell response through OX40 ligand. *J Exp Med* 2005;202:1213–23.
  128. Soumelis V, Reche PA, Kanzler H, Yuan W, Edward G, Homey B, et al. Human epithelial cells trigger dendritic cell mediated allergic inflammation by producing TSLP. *Nat Immunol* 2002;3:673–80.
  129. Holgate ST. Pathogenesis of asthma. *Clin Exp Allergy* 2008;38:872–97.
  130. Bonasio R, von Andrian UH. Generation, migration and function of circulating dendritic cells. *Curr Opin Immunol* 2006;18:503–11.
  131. Dua B, Smith S, Kinoshita T, Imaoka H, Gauvreau G, O'Byrne P. Myeloid dendritic cells type 2 in allergic asthma. *Allergy* 2013;68:1322–6.
  132. Kadowaki N, Ho S, Antonenko S, Malefyt RW, Kastelein RA, Bazan F, et al. Subsets of human dendritic cell precursors express different toll-like receptors and respond to different microbial antigens. *J Exp Med* 2001;194:863–9.
  133. Jonuleit H, Schmitt E, Schuler G, Knop J, Enk AH. Induction of interleukin 10-producing, nonproliferating CD4(+) T cells with regulatory properties by repetitive stimulation with allogeneic immature human dendritic cells. *J Exp Med* 2000;192:1213–22.
  134. Risoan M-C, Soumelis V, Kadowaki N, Grouard G, Briere F, De Waal Malefyt R, et al. Reciprocal control of T helper cell and dendritic cell differentiation. *Science* 1999;283:1183–6.
  135. Zheng J, Jiang H, Li J, Tang H, Zhang X, Wang X, et al. MicroRNA-23b promotes tolerogenic properties of dendritic cells in vitro through inhibiting Notch1/NF-kappa B1 signalling pathways. *Allergy* 2012;67:362–70.
  136. Abbas AK, Benoist C, Bluestone JA, Campbell DJ, Ghosh S, Hori S, et al. Regulatory T cells: recommendations to simplify the nomenclature. *Nat Immunol* 2013;14:307–8.
  137. Chen W, Liang X, Peterson AJ, Munn DH, Blazar BR. The indoleamine 2,3-dioxygenase pathway is essential for human plasmacytoid dendritic cell-induced adaptive T regulatory cell generation. *J Immunol* 2008;181:5396–404.
  138. Ito T, Yang M, Wang YH, Lande R, Gregorio J, Perng OA, et al. Plasmacytoid dendritic cells prime IL-10-producing T regulatory cells by inducible costimulator ligand. *J Exp Med* 2007;204:105–15.

139. de Heer HJ, Hammad H, Soullie T, Hijdra D, Vos N, Willart MA, et al. Essential role of lung plasmacytoid dendritic cells in preventing asthmatic reactions to harmless inhaled antigen. *J Exp Med* 2004;200:89–98.
140. Galli SJ, Tsai M. IgE and mast cells in allergic disease. *Nat Med* 2012;18:693–704.
141. Brightling CE, Bradding P, Symon FA, Holgate ST, Wardlaw AJ, Pavord ID. Mast-cell infiltration of airway smooth muscle in asthma. *N Engl J Med* 2002;346:1699–705.
142. Ordonez CL, Shaughnessy TE, Matthay MA, Fahy JV. Increased neutrophil numbers and IL-8 levels in airway secretions in acute severe asthma: clinical and biologic significance. *Am J Respir Crit Care Med* 2000;161:1185–90.
143. Perrigoue JG, Saenz SA, Siracusa MC, Allenspach EJ, Taylor BC, Giacomin PR, et al. MHC class II-dependent basophil-CD4+ T cell interactions promote T(H)2 cytokine-dependent immunity. *Nat Immunol* 2009;10:697–705.
144. Yoshimoto T, Yasuda K, Tanaka H, Nakahira M, Imai Y, Fujimori Y, et al. Basophils contribute to T(H)2-IgE responses in vivo via IL-4 production and presentation of peptide-MHC class II complexes to CD4+ T cells. *Nat Immunol* 2009;10:706–12.
145. Schroeder JT, Lichtenstein LM, Roche EM, Xiao H, Liu MC. IL-4 production by human basophils found in the lung following segmental allergen challenge. *J Allergy Clin Immunol* 2001;107:265–71.
146. Hammad H, Plantinga M, Deswarte K, Pouliot P, Willart MA, Kool M, et al. Inflammatory dendritic cells – not basophils – are necessary and sufficient for induction of Th2 immunity to inhaled house dust mite allergen. *J Exp Med* 2010;207:2097–111.
147. Akbari O, Stock P, Meyer E, Kronenberg M, Sidobre S, Nakayama T, et al. Essential role of NKT cells producing IL-4 and IL-13 in the development of allergen-induced airway hyperreactivity. *Nat Med* 2003;9:582–8.
148. Pichavant M, Goya S, Meyer EH, Johnston RA, Kim HY, Matangkasombut P, et al. Ozone exposure in a mouse model induces airway hyperreactivity that requires the presence of natural killer T cells and IL-17. *J Exp Med* 2008;205:385–93.
149. Kim EY, Battaile JT, Patel AC, You Y, Agapov E, Grayson MH, et al. Persistent activation of an innate immune response translates respiratory viral infection into chronic lung disease. *Nat Med* 2008;14:633–40.
150. Matangkasombut P, Marigowda G, Ervine A, Idris L, Pichavant M, Kim HY, et al. Natural killer T cells in the lungs of patients with asthma. *J Allergy Clin Immunol* 2009;123:1181–5.
151. Korsgren M, Persson CG, Sundler F, Bjerke T, Hansson T, Chambers BJ, et al. Natural killer cells determine development of allergen-induced eosinophilic airway inflammation in mice. *J Exp Med* 1999;189:553–62.
152. Broide D, Schwarze J, Tighe H, Gifford T, Nguyen MD, Malek S, et al. Immunostimulatory DNA sequences inhibit IL-5, eosinophilic inflammation, and airway hyperresponsiveness in mice. *J Immunol* 1998;161:7054–62.
153. Deniz G, Erten G, Kucuksezer UC, Kocacik D, Karagiannidis C, Aktas E, et al. Regulatory NK cells suppress antigen-specific T cell responses. *J Immunol* 2008;180:850–7.
154. Schramm CM, Puddington L, Yamouyiannis CA, Lingenheld EG, Whiteley HE, Wolyniec WW, et al. Proinflammatory roles of T-cell receptor (TCR)γδ and TCRαβ lymphocytes in a murine model of asthma. *Am J Respir Cell Mol Biol* 2000;22:218–25.
155. Krug N, Erpenbeck VJ, Balke K, Petschallies J, Tschernig T, Hohlfeld JM, et al. Cytokine profile of bronchoalveolar lavage-derived CD4(+), CD8(+), and γδ T cells in people with asthma after segmental allergen challenge. *Am J Respir Cell Mol Biol* 2001;25:125–31.
156. Spinazzi F, Agea E, Bistoni O, Forenza N, Monaco A, Bassotti G, et al. Increased allergen-specific, steroid-sensitive gamma delta T cells in bronchoalveolar lavage fluid from patients with asthma. *Ann Intern Med* 1996;124:223–7.
157. Chen KS, Miller KH, Hengehold D. Diminution of T cells with gamma delta receptor in the peripheral blood of allergic asthmatic individuals. *Clin Exp Allergy* 1996;26:295–302.
158. Stanciu LA, Shute J, Promwong C, Holgate ST, Djukanovic R. Increased levels of IL-4 in CD8+ T cells in atopic asthma. *J Allergy Clin Immunol* 1997;100:373–8.
159. Magnan AO, Mely LG, Camilla CA, Badier MM, Montero-Julian FA, Guillot CM, et al. Assessment of the Th1/Th2 paradigm in whole blood in atopy and asthma. Increased IFN-γ-producing CD8(+) T cells in asthma. *Am J Respir Crit Care Med* 2000;161:1790–6.
160. Gorski SA, Hahn YS, Braciale TJ. Group 2 innate lymphoid cell production of IL-5 is regulated by NKT cells during influenza virus infection. *PLoS Pathog* 2013;9:e1003615.
161. Klein Wolterink RG, Kleijnan A, van Nimwegen M, Bergen I, de Bruijn M, Levani Y, et al. Pulmonary innate lymphoid cells are major producers of IL-5 and IL-13 in murine models of allergic asthma. *Eur J Immunol* 2012;42:1106–16.
162. Holgate ST, Davies DE, Lackie PM, Wilson SJ, Puddicombe SM, Lordan JL. Epithelial-mesenchymal interactions in the pathogenesis of asthma. *J Allergy Clin Immunol* 2000;105:193–204.
163. Van Eerdewegh P, Little RD, Dupuis J, Del Mastro RG, Falls K, Simon J, et al. Association of the ADAM33 gene with asthma and bronchial hyperresponsiveness. *Nature* 2002;418:426–30.
164. Palomares O, Martin-Fontecha M, Lauener R, Traidl-Hoffmann C, Cavkaytar O, Akdis M, et al. Regulatory T cells and immune regulation of allergic diseases: roles of IL-10 and TGF-β. *Genes Immun* 2014;15:511–20.
165. Vercelli D. Gene-environment interactions in asthma and allergy: the end of the beginning? *Curr Opin Allergy Clin Immunol* 2010;10:145–8.
166. Palmer CN, Ismail T, Lee SP, Terron-Kwiatkowski A, Zhao Y, Liao H, et al. Filaggrin null mutations are associated with increased asthma severity in children and young adults. *J Allergy Clin Immunol* 2007;120:64–8.
167. Lamkhouiou B, Renzi PM, Abi-Younes S, Garcia-Zepeda EA, Allakhverdi Z, Ghaffar O, et al. Increased expression of eotaxin in bronchoalveolar lavage and airways of asthmatics contributes to the chemotaxis of eosinophils to the site of inflammation. *J Immunol* 1997;159:4593–601.
168. Kunkel EJ, Butcher EC. Chemokines and the tissue-specific migration of lymphocytes. *Immunity* 2002;16:1–4.
169. Kumagai K, Ohno I, Okada S, Ohkawara Y, Suzuki K, Shinya T, et al. Inhibition of matrix metalloproteinases prevents allergen-induced airway inflammation in a murine model of asthma. *J Immunol* 1999;162:4212–19.
170. Corry DB, Rishi K, Kanellis J, Kiss A, Song LZ, Xu J, et al. Decreased allergic lung inflammatory cell egression and increased susceptibility to asphyxiation in MMP2-deficiency. *Nat Immunol* 2002;3:347–53.
171. De Benedetto A, Rafaels NM, McGirt LY, Ivanov AI, Georas SN, Cheadle C, et al. Tight junction defects in patients with atopic dermatitis. *J Allergy Clin Immunol* 2011;127:773–86, e7.
172. Xiao C, Puddicombe SM, Field S, Haywood J, Broughton-Head V, Puxeddu I, et al. Defective epithelial barrier function in asthma. *J Allergy Clin Immunol* 2011;128:549–56, e1–12.
173. Soyka MB, Wawrzyniak P, Eiwegger T, Holzmann D, Treis A, Wanke K, et al. Defective epithelial barrier in chronic rhinosinusitis: the regulation of tight junctions by IFN-γ and IL-4. *J Allergy Clin Immunol* 2012;130:1087–96.
174. Kast JI, Wanke K, Soyka MB, Wawrzyniak P, Akdis D, Kingo K, et al. The broad spectrum of interepithelial junctions in skin and lung. *J Allergy Clin Immunol* 2012;130:544–7, e4.
175. Mineta K, Yamamoto Y, Yamazaki Y, Tanaka H, Tada Y, Saito K, et al. Predicted expansion of the claudin multigene family. *FEBS Lett* 2011;585:606–12.
176. Papadopoulos NG, Christodoulou I, Rohde G, Agache I, Almqvist C, Bruno A, et al. Viruses and bacteria in acute asthma exacerbations – a GA(2) LEN-DARE systematic review. *Allergy* 2011;66:458–68.
177. Message SD, Laza-Stanca V, Mallia P, Parker HL, Zhu J, Kebabdzte T, et al. Rhinovirus-induced lower respiratory illness is increased in asthma and related to virus load and Th1/2 cytokine and IL-10 production. *Proc Natl Acad Sci U S A* 2008;105:13562–7.
178. O'Sullivan S, Cormican L, Faul JL, Ichinohe S, Johnston SL, Burke CM, et al. Activated, cytotoxic CD8(+) T lymphocytes contribute to the pathology of asthma death. *Am J Respir Crit Care Med* 2001;164:560–4.
179. Kusel MM, de Klerk NH, Kebabdzte T, Vohma V, Holt PG, Johnston SL, et al. Early-life respiratory viral infections, atopic sensitization, and risk of subsequent development of persistent asthma. *J Allergy Clin Immunol* 2007;119:1105–10.
180. Stensballe LG, Kristensen K, Simoes EA, Jensen H, Nielsen J, Benn CS, et al. Atopic disposition, wheezing, and subsequent respiratory syncytial virus hospitalization in Danish children younger than 18 months: a nested case-control study. *Pediatrics* 2006;118:e1360–8.
181. Wang H, Su Z, Schwarze J. Healthy but not RSV-infected lung epithelial cells profoundly inhibit T cell activation. *Thorax* 2009;64:283–90.
182. Tourdot S, Mathie S, Hussell T, Edwards L, Wang H, Openshaw PJ, et al. Respiratory syncytial virus infection provokes airway remodeling in allergen-exposed mice in absence of prior allergen sensitization. *Clin Exp Allergy* 2008;38:1016–24.

183. Chen CH, Lin YT, Yang YH, Wang LC, Lee JH, Kao CL, et al. Ribavirin for respiratory syncytial virus bronchiolitis reduced the risk of asthma and allergen sensitization. *Pediatr Allergy Immunol* 2008;19:166–72.
184. Simoes EA, Groothuis JR, Carbonell-Estrany X, Rieger CH, Mitchell I, Fredrick LM, et al. Palivizumab prophylaxis, respiratory syncytial virus, and subsequent recurrent wheezing. *J Pediatr* 2007;151:34–42, e1.
185. Yazdanbakhsh M, Kremsner PG, van Ree R. Immunology – allergy, parasites, and the hygiene hypothesis. *Science* 2002;296:490–4.
186. Bach JF. The effect of infections on susceptibility to autoimmune and allergic diseases. *N Engl J Med* 2002;347:911–20.
187. Kalliomaki M, Salminen S, Arvilommi H, Kero P, Koskinen P, Isolauri E. Probiotics in primary prevention of atopic disease: a randomised placebo-controlled trial. *Lancet* 2001;357:1076–9.
188. Heederik D, von Mutius E. Does diversity of environmental microbial exposure matter for the occurrence of allergy and asthma? *J Allergy Clin Immunol* 2012;130:44–50.
189. Gehring U, Bolte G, Borte M, Bischof W, Fahlbusch B, Wichmann HE, et al. Exposure to endotoxin decreases the risk of atopic eczema in infancy: a cohort study. *J Allergy Clin Immunol* 2001;108:847–54.
190. Palomares O. The role of regulatory T cells in IgE-mediated food allergy. *J Investig Allergol Clin Immunol* 2013;23:371–82, quiz 2 p preceding 82.
191. Burks AW, Calderon MA, Casale T, Cox L, Demoly P, Jutel M, et al. Update on allergy immunotherapy: American Academy of Allergy, Asthma & Immunology/European Academy of Allergy and Clinical Immunology/PRACTALL consensus report. *J Allergy Clin Immunol* 2013;131:1288–96, e3.
192. Moller C, Dreborg S, Ferdousi HA, Halken S, Host A, Jacobsen L, et al. Pollen immunotherapy reduces the development of asthma in children with seasonal rhinoconjunctivitis (the PAT-study). *J Allergy Clin Immunol* 2002;109:251–6.
193. Creticos PS, Schroeder JT, Hamilton RG, Balcer-Whaley SL, Khattignavong AP, Lindblad R, et al. Immunotherapy with a ragweed-toll-like receptor 9 agonist vaccine for allergic rhinitis. *N Engl J Med* 2006;355:1445–55.
194. Gevaert P, Calus L, Van Zele T, Blomme K, De Ruyck N, Bauters W, et al. Omalizumab is effective in allergic and nonallergic patients with nasal polyps and asthma. *J Allergy Clin Immunol* 2013;131:110–6, e1.

# Guidelines for Treatment of Asthma: A Global Concern

ALLAN BECKER

## KEY POINTS

- Guideline development is increasingly driven by published data (i.e. evidence based).
- Guidelines increasingly focus on asthma control rather than severity.
- Asthma control defines current 'impairment' and provides an indication of 'future risk' for an exacerbation.
- For the young child with asthma there are limited published data to help direct recommendations for assessment and management strategies.
- Implementation of guidelines is a major challenge which national or global guideline strategies and local champions can help to direct.

## Guideline Development

By the late 1980s, it was apparent that an epidemic of asthma had begun, particularly among children.<sup>1</sup> This was emphasized by the dramatically increased mortality rates for asthma in New Zealand,<sup>2</sup> which became the impetus for Australia and New Zealand to establish the first guidelines for the management of asthma in 1989.<sup>3</sup> Shortly thereafter, consensus reports by expert panels on asthma assessment and management from Canada<sup>4</sup> and from Britain<sup>5</sup> were published as guidelines. This was followed shortly by the National Asthma Education and Prevention Program (NAEPP) Expert Panel Report from the USA in 1991.<sup>6</sup> These early guidelines were based on expert opinion and provided consensus approaches to the diagnosis and management of asthma.

The first international consensus report was coordinated by the National Heart Lung and Blood Institute (NHLBI) and published by the National Institutes of Health (NIH) in 1992.<sup>7</sup> Subsequently, the NHLBI, in cooperation with the World Health Organization, launched the Global Initiative for Asthma (GINA) in 1993. The first GINA report was published by the NIH in 1995 as a 'Global Strategy for Asthma Management and Prevention.'<sup>8</sup> This was the first publication that aimed to provide a global approach to asthma and especially focussed on developing countries. As with previous guidelines, this was representative of expert opinion and consensus among those experts as to the best approach to asthma management.

Each of the initial guidelines primarily focussed on asthma in adults. Exemplary of the problems with developing a consensus around asthma in childhood was the situation at the initial Canadian Consensus Conference in 1989. At that workshop, pediatricians met as a separate subgroup to discuss the

recommendations which were evolving within the expert group as a whole. Given the relative lack of research in children with asthma and a wide range of expert opinion on optimal approaches to treatment, the pediatricians were unable to develop any consensus focusing on the management of asthma in the pediatric population. However, over the next few years, pediatric-focussed guidelines began to emerge from national guideline committees with one of the earliest being from the British Thoracic Society<sup>9</sup> in the mid-1990s. From that document, it became clear that separate categories and approaches to the diagnosis and management of asthma would be essential for school-aged children and for preschool children if the very best recommendations were to be developed. This was one of the first guidelines to bring focus to the issue of pediatric asthma, especially to recognition of the fact that there were few data upon which to build any recommended interventions for management of asthma in the young child.

## Evidence-Based Medicine

The development of the initial asthma guidelines was driven by expert opinion and these were consensus based. However, by the early 1990s it was recognized that it would be important to define the quality of data and to begin to focus on evidence-based recommendations. Unfortunately, as evidenced by the very carefully structured British Thoracic Society guidelines, when an attempt was undertaken to rigorously define the quality of evidence for management of asthma in children, the best available evidence for pediatric asthma remained at the lowest level of quality (i.e. expert opinion generating a consensus).<sup>9</sup> The levels of evidence used in a number of guidelines, including the GINA strategy and the NAEPP guidelines, are shown in [Table 29-1](#). This approach still underpins current GINA and NAEPP recommendations, including those recommendations for children.

Although the initial pediatric guideline recommendations reflected expert opinion, an important outcome was the recognition that there was a substantial lack of data to help guide recommendations for the management of children with asthma. As a result, a key component of the first Canadian Pediatric Asthma Guidelines<sup>10</sup> published in 2005 was a section entitled 'Implications for Research.' This important component of a number of national guidelines was a stimulus toward promoting research in children and recognizes in particular that the development of the majority of cases of asthma begins in the preschool years<sup>11</sup> ([Figure 29-1](#)).

Increasing research in childhood asthma was important in facilitating development of the National Heart Lung and Blood Institute National Education Prevention Program Expert Panel Report 3: Guidelines for the diagnosis and management of



TABLE  
29-1

Evidence Level	Sources of Evidence	Definition
A	Randomized controlled trials (RCTs) and meta-analyses Rich body of data	Evidence is from end-points of well-designed RCTs or meta-analyses that provide a consistent pattern of findings in the population for which the recommendation is made Category A requires substantial numbers of studies involving substantial numbers of participants
B	RCTs and meta-analyses Limited body of data	Evidence is from end-points of intervention studies that include only a limited number of patients, post hoc or subgroup analysis of RCTs or meta-analysis of such RCTs In general, Category B pertains when few randomized trials exist, they are small in size, they were undertaken in a population that differs from the target population of the recommendation, or the results are somewhat inconsistent
C	Non-randomized trials Observational studies	Evidence is from outcomes of uncontrolled or non-randomized trials or from observational studies
D	Panel consensus judgment	This category is used only in cases where the provision of some guidance was deemed valuable, but the clinical literature addressing the subject was insufficient to justify placement in one of the other categories The Panel Consensus is based on clinical experience or knowledge that does not meet the criteria listed above

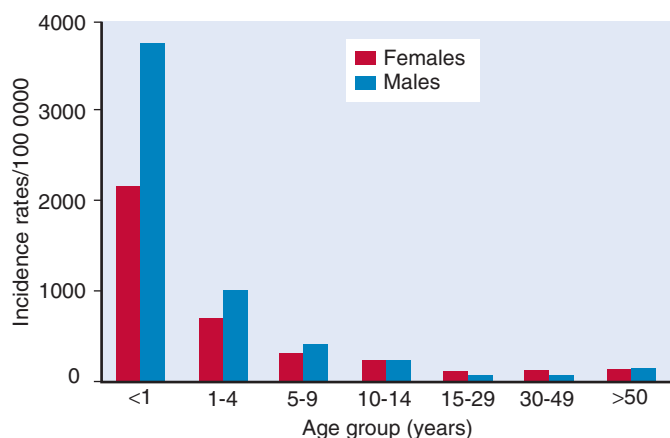

**Figure 29-1** Annual incident rates per 100,000 person-years by sex and range for definite + probable asthma cases among Rochester residents 1964–1983. (Data from Yunginger JW, Reed CE, O’Connell EJ, Melton LJ 3rd, O’Fallon WM, Silverstein MD. A community-based study of the epidemiology of asthma. Incidence rates, 1964–1983. *Am Rev Respir Dis* 1992;146(4):888–94.)

asthma published in 2007.<sup>12</sup> In that report, there was a strong focus on asthma in the preschool years (children 0–4 years of age) and in school-age children (5–11 years of age). Although there has been more research relating to asthma and the young child over the past decade, data to substantially update guidelines for children with asthma during the preschool years remain limited. In 2008, GINA approached the issue of asthma in the young child and established a panel of pediatric asthma experts to focus on the issues of concern in these young, preschool children. In 2009, GINA published the ‘Global Strategy for Asthma Management and Prevention in Children 5 Years and Younger’ with an emphasis on challenges in the diagnosis and management of asthma in these preschool children.<sup>13</sup> Recommendations in the report were based on the best evidence available. However, because of the relative paucity of randomized or even observational clinical trials in this population, many recommendations remained at level D, i.e. panel consensus judgment. The expert opinion approach based on available data and consensus opinion published by GINA provides a strategy for the development of guidelines by local and national

organizations which are pertinent to their specific population characteristics, available healthcare resources and local or national environments.

Guidelines are commonly developed by a panel of experts where the intent is to produce recommendations based on the best evidence available. Increasingly, there are pressures to produce recommendations based on the quality of a body of evidence assessed independently by a multidisciplinary team. Increasing adherence and focus to better define the quality of evidence remains a problem where there is a lack of substantive data. This is most apparent in the assessment and management of asthma in children during the preschool years. We require substantially more research in this area, both more structured randomized controlled trials and improved observational studies. Until such data are more abundant, guideline recommendations for the young child will continue to rest on expert panels with the appropriate clinical experience to provide the best possible recommendations for consideration in the development of local and national guidelines.

## Asthma Severity and Control

Initially, most asthma guidelines focussed on defining levels of asthma severity. However, conceptually to guidelines developers, and of particular importance to patients with asthma and their families, asthma control is a far more important focus. As the focus in guideline development shifted to assessment of asthma control, it became increasingly apparent that asthma control should be considered within two distinct domains: symptom control, which can be considered to represent the current level of ‘impairment’, and ‘future risk’ for asthma worsening or exacerbation. These domains are now well recognized and are regularly an important component of guidelines. As noted in the previous edition of this textbook, ‘Impairment is the assessment of the frequency and intensity of symptoms as well as the functional limitations that the patient is experiencing now or in the past because of his or her asthma. Risk is the estimate of the likelihood of an asthma exacerbation, progressive loss of pulmonary function over time caused by asthma, or an adverse event from medication or even death. The assessment of severity and control provide guidance on the direction taken, stepping up or stepping down medications.’<sup>14</sup>

TABLE  
29-2

## GINA Assessment of Asthma Control in Children 5 Years and Younger

A. SYMPTOM CONTROL		LEVEL OF ASTHMA SYMPTOM CONTROL		
In The Past 4 Weeks, Has the Child Had:		Well Controlled	Partly Controlled	Uncontrolled
• Daytime asthma symptoms for more than a few minutes, more than once a week?	Yes <input type="checkbox"/> No <input type="checkbox"/>	None of these	1–2 of these	3–4 of these
• Any activity limitation due to asthma? (Runs/plays less than other children, tires easily during walks/playing?)	Yes <input type="checkbox"/> No <input type="checkbox"/>			
• Reliever medication needed* more than once a week?	Yes <input type="checkbox"/> No <input type="checkbox"/>			
• Any night waking or night coughing due to asthma?	Yes <input type="checkbox"/> No <input type="checkbox"/>			
<b>B. FUTURE RISK FOR POOR ASTHMA OUTCOMES</b>				
Risk Factors for Asthma Exacerbations within the Next Few Months				
<ul style="list-style-type: none"> <li>• Uncontrolled asthma symptoms</li> <li>• One or more severe exacerbation in previous year</li> <li>• The start of the child's usual 'flare-up' season (especially if fall/autumn)</li> <li>• Exposures: tobacco smoke; indoor or outdoor air pollution; indoor allergens (e.g. house dust mite, cockroach, pets, mold), especially in combination with viral infection</li> <li>• Major psychological or socioeconomic problems for child or family</li> <li>• Poor adherence with controller medication, or incorrect inhaler technique</li> </ul>				
Risk Factors for Fixed Airflow Limitation				
<ul style="list-style-type: none"> <li>• Severe asthma with several hospitalizations</li> <li>• History of bronchiolitis</li> </ul>				
Risk Factors for Medication Side-Effects				
<ul style="list-style-type: none"> <li>• Systemic: Frequent courses of OCS; high-dose and/or potent ICS</li> <li>• Local: moderate/high-dose or potent ICS; incorrect inhaler technique; failure to protect skin or eyes when using ICS by nebulizer or spacer with face mask</li> </ul>				

ICS – inhaled corticosteroids, OCS – oral corticosteroids.

\*Excludes reliever taken before exercise

This GINA asthma symptom control classification corresponds to 'current control' in GINA pediatric report 2009. Before stepping up treatment, ensure that the child's symptoms are due to asthma, and that the child has good inhaler technique and good adherence to existing treatment.

One example of asthma control parameters is the GINA 2014 assessment of asthma control for children 5 years and younger (Table 29-2).<sup>15</sup> For older children, the additional measurement of forced expiratory volume in 1 second (FEV<sub>1</sub>) contributes to a better understanding of the risk factors for future asthma control. Whenever possible, pulmonary function should be a routine component of asthma assessments.

## Management of Asthma for Children

Asthma therapy must take into consideration the level of asthma symptom control (i.e. impairment) and future risk. In school-age children, this tends to be rather more straightforward than in the preschool child with recurrent wheezing episodes and a less certain asthma diagnosis. Although 'not all that wheezes is asthma', much of what wheezes or has severe, paroxysmal cough is treated as asthma. While there is increasing recognition of the heterogeneity of asthma phenotypes at all ages, management of wheezing syndromes in early life is a particular problem. Many children with asthma during the preschool years have only infrequent episodes of viral-induced wheezing and few, if any, interval symptoms. However, even if infrequent, these wheezing episodes can be quite severe. Thus, symptom frequency and severity are not equally matched. The optimal management of these children remains a concern to many healthcare professionals. In addition, in many countries, there are limited 'approved' medications for use in this population. This is a problem in a population most in need of research but difficult to study in large part because of the lack of objective outcome

parameters. As a result, 'expert opinion' and general consensus remain the core of most recommendations. Further, this is a population in which long-term adverse effects of most interventions remain poorly studied.

For school-age children, the approach to management remains similar to that for the adolescent and adult populations. Figure 29-2 from the most recent GINA Global Strategy for Asthma Management and Prevention, revised 2014, provides treatment recommendations for the preschool child with asthma.<sup>15</sup> It is representative of a 'typical' approach to management of asthma in the young child based on the available data (often extrapolated from studies in older children) as interpreted by 'asthma experts'.

Regardless of the pharmacological approach to the management of asthma, all guidelines continue to support the importance of education for children and their families.

## Have Guidelines Benefitted Children and Their Families?

Although the appraisal of guidelines, research and evaluation (AGREE) process defines the quality of asthma guidelines to be 'low', asthma guidelines do continue to improve.<sup>16</sup> A recent editorial questioned whether practice guidelines are of any benefit to patients.<sup>17</sup> After all, benefits to children and their families should be the primary objective for framing pediatric guideline development. The author of that editorial suggested that 'Published guidelines are therefore not an adequate

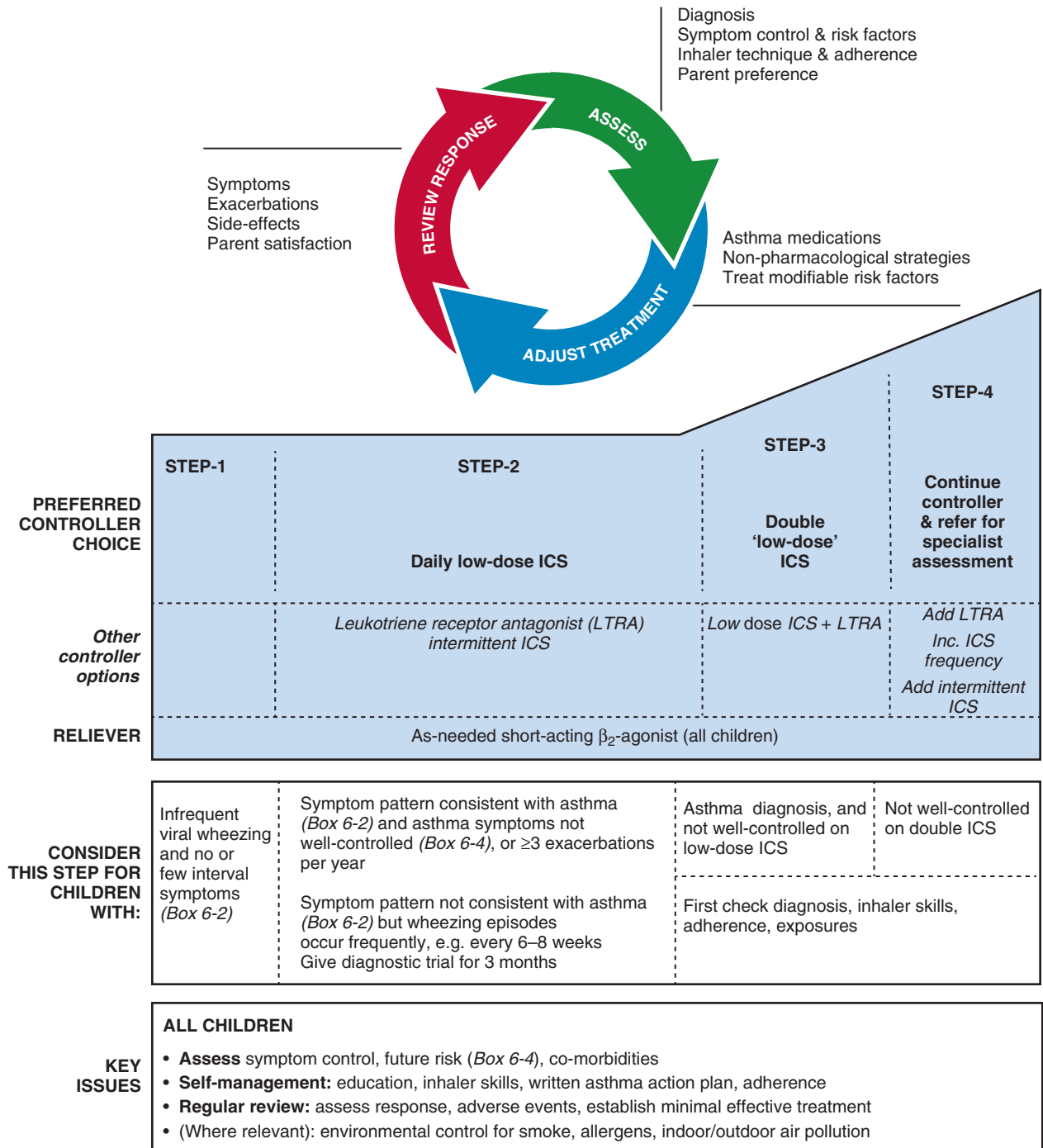

ICS: inhaled corticosteroid; intermitt: intermittent. See Box 6-6 for definition of 'low-dose' ICS in children 5 years and younger.

**Figure 29-2** Stepwise approach to long-term management of asthma in children aged 5 years and younger.

substitute for actual successful clinical experience by specialists during residency.<sup>17</sup> Although this is not a simple issue, it may be particularly important for young children, and the concerns raised in that editorial must be addressed. Development of guidelines is typically followed by widespread dissemination of a document, usually with substantial documentation as to the quality of recommendations. As previously noted, 'Of necessity to establish the quality, or weight, of the recommendations, the documents must present data and... the quality and depth of

material also supports the likelihood of publication to enable these primary dissemination approaches.'<sup>18</sup> These 'weighty' documents are frequently translated into shortened summary publications and often one- or two-page pocket guides are developed which can be particularly helpful to trainees and primary care physicians.

While dissemination is generally considered to be straightforward, implementation of guidelines has been a major concern, particularly at the local level. There have been a

number of studies aimed at improving adherence to asthma guidelines. A recent systematic review demonstrated that use of decision support tools with feedback on audit and support from a clinical pharmacy were the most likely approaches to improve provider adherence to asthma guidelines.<sup>19</sup> However, even with complicated and expensive interventions, only a limited number of studies have been associated with an improvement in health-care status.<sup>19</sup> A recent review asked 'Have expert guidelines made a difference in asthma outcomes?'<sup>20</sup> That review, which considered both controlled and observational trials, was unable to demonstrate substantive impact on health outcomes and noted that we need to 'better understand the gaps between guidelines recommendations and translation to clinical practice... to improve asthma outcomes.'<sup>20</sup> Nevertheless, there are studies, such as one from Costa Rica, that demonstrate

substantive impact with decreasing trends in hospitalization and mortality from asthma after institution of a national asthma program.<sup>21</sup>

The quality of asthma guidelines has improved over time.<sup>16</sup> It is increasingly clear that guidelines are important in order to provide the best available data combined with advice based on expert opinion. However, to be of benefit to patients and their families, adaptation and implementation of guidelines must be undertaken at national and, possibly even better, at local levels, and supported by local champions with appropriate stakeholder involvement.<sup>22</sup>

The complete reference list can be found on the companion Expert Consult website at <http://www.expertconsult.inkling.com>.



## KEY REFERENCES

- Jackson RT, Beaglehole R, Rea HH, Sutherland DC. Mortality from asthma: a new epidemic in New Zealand. *Br Med J* 1982;285:771-4.
- Woolcock A, Rubinfeld AR, Seale JP, Landau LL, Antic R, Mitchell C, et al. Thoracic society of Australia and New Zealand. Asthma management plan, 1989. *Med J Aust* 1989;151:650-3.
- International consensus report on diagnosis and treatment of asthma. National heart, lung, and blood institute, national institutes of health. Bethesda, Maryland 20892. Publication no. 92-3091, March 1992. *Eur Respir J* 1992;5:601-41.
- British Thoracic Society. The British guidelines on asthma management; 1995 review and position statement. *Thorax* 1997;52:S1-21.
- Becker A, Berube D, Chad Z, Dolovich M, Ducharme F, D'Urzo T, et al. Canadian Pediatric Asthma Consensus guidelines, 2003 (updated to December 2004): introduction. *CMAJ* 2005;173(Suppl. 6):S12-14.
- Yunginger JW, Reed CE, O'Connell EJ, Melton LJ 3rd, O'Fallon WM, Silverstein MD. A community-based study of the epidemiology of asthma. Incidence rates, 1964-1983. *Am Rev Respir Dis* 1992;146:888-94.
- National Institutes of Health. National Heart, Lung and Blood Institute. National asthma education and prevention program: expert panel report 3: guidelines for the diagnosis and management of asthma. NIH; 2007.
- Global Initiative for Asthma. Global strategy for asthma management and prevention. 2009. Available from [www.ginasthma.org](http://www.ginasthma.org).
- Global Initiative for Asthma. Global strategy for asthma management and prevention. 2014. Available from [www.ginasthma.org](http://www.ginasthma.org).
- Podjasek JC, Rank MA. Have expert guidelines made a difference in asthma outcomes? *Curr Opin Allergy Clin Immunol* 2013;13:237-43.



## REFERENCES

- Manfreda J, Becker AB, Wang PZ, Roos LL, Anthonisen NR. Trends in physician-diagnosed asthma prevalence in Manitoba between 1980 and 1990. *Chest* 1993;103:151–7.
- Jackson RT, Beaglehole R, Rea HH, Sutherland DC. Mortality from asthma: a new epidemic in New Zealand. *Br Med J* 1982;285:771–4.
- Woolcock A, Rubinfeld AR, Seale JP, Landau LL, Antic R, Mitchell C, et al. Thoracic society of Australia and New Zealand. Asthma management plan, 1989. *Med J Aust* 1989;151:650–3.
- Hargreave FE, Dolovich J, Newhouse MT. The assessment and treatment of asthma: a conference report. *J Allergy Clin Immunol* 1990;85:1098–111.
- Guidelines for management of asthma in adults: I – Chronic persistent asthma. Statement by the British Thoracic Society, Research Unit of the Royal College of Physicians of London, King's Fund Centre, National Asthma Campaign. *BMJ* 1990;301:651–3.
- Guidelines for the diagnosis and management of asthma. National heart, lung, and blood institute. National asthma education program. Expert Panel Report. *J Allergy Clin Immunol* 1991;88(3 Pt 2):425–534.
- International consensus report on diagnosis and treatment of asthma. National heart, lung, and blood institute, national institutes of health. Bethesda, Maryland 20892. Publication no. 92-3091, March 1992. *Eur Respir J* 1992;5:601–41.
- National Heart, Lung and Blood Institute and World Health Organization. Global initiative for asthma. NIH; 1995.
- British Thoracic Society. The British guidelines on asthma management; 1995 review and position statement. *Thorax* 1997;52:S1–21.
- Becker A, Berube D, Chad Z, Dolovich M, Ducharme F, D'Urzo T, et al. Canadian Pediatric Asthma Consensus guidelines, 2003 (updated to December 2004): introduction. *CMAJ* 2005;173(Suppl. 6):S12–14.
- Yunginger JW, Reed CE, O'Connell EJ, Melton LJ 3rd, O'Fallon WM, Silverstein MD. A community-based study of the epidemiology of asthma. Incidence rates, 1964–1983. *Am Rev Respir Dis* 1992;146:888–94.
- National Institutes of Health. National Heart, Lung and Blood Institute. National asthma education and prevention program: expert panel report 3: guidelines for the diagnosis and management of asthma. NIH; 2007.
- Global Initiative for Asthma. Global strategy for asthma management and prevention. 2009. Available from [www.ginasthma.org](http://www.ginasthma.org).
- Szefer S. Guidelines for the treatment of childhood asthma: gains and opportunities. In: Leung DYM, Sampson HA, Geha R, Szefer SJ, editors. *Pediatric allergy: principles and practice*. 2nd ed. Mosby; 2011.
- Global Initiative for Asthma. Global strategy for asthma management and prevention. 2014. Available from [www.ginasthma.org](http://www.ginasthma.org).
- Acuna-Izcaray A, Sanchez-Angarita E, Plaza V, Rodrigo G, Montes de Oca M, Gich I, et al. Quality assessment of asthma clinical practice guidelines: a systematic appraisal. *Chest* 2013;144:390–7.
- Weinberger M. NHLBI asthma guidelines: no benefit for patients? *Pediatr Pulmonol* 2012;47:632–4.
- Becker A. Pediatric asthma guidelines: what are they good for? A view from the 'pro' side. *Pediatr Pulmonol* 2012;47:629–31.
- Okelo SO, Butz AM, Sharma R, Diette GB, Pitts SI, King TM, et al. Interventions to modify health care provider adherence to asthma guidelines: a systematic review. *Pediatrics* 2013;132:517–34.
- Podjasek JC, Rank MA. Have expert guidelines made a difference in asthma outcomes? *Curr Opin Allergy Clin Immunol* 2013;13:237–43.
- Soto-Martinez M, Avila L, Soto N, Chaves A, Celedon JC, Soto-Quiros ME. Trends in hospitalizations and mortality from asthma in Costa Rica over a 12- to 15-year period. *J Allergy Clin Immunol Pract* 2014;2:85–90.
- Boulet LP, FitzGerald JM, Levy ML, Cruz AA, Pedersen S, Haahtela T, et al. A guide to the translation of the Global Initiative for Asthma (GINA) strategy into improved care. *Eur Respir J* 2012;39:1220–9.

# Functional Assessment of Asthma

DAVID P. NICHOLS

## KEY POINTS

- Asthma pathology has defining physiologic correlates, including airflow limitation, heightened airway responsiveness to stimuli and improved airflow in response to bronchodilators.
- Spirometry is the most common quantitative test used to measure airflow obstruction.
- Serial tests of lung function are valuable in following the course of asthma.
- Decreases in airflow plus hyperinflation (i.e. air trapping) are seen in acute asthma.
- During exacerbations, signs and symptoms of asthma often resolve before lung function returns to normal.
- Hypoxemia is common in asthma exacerbations while hypercapnia is a sign of more severe airflow limitation.

Asthma is characterized by intermittent airway obstruction, which commonly manifests as shortness of breath, cough, wheezing and chest tightness. However, even moderate degrees of airflow obstruction may not be symptomatic or clinically apparent. When present, the degree of airflow limitation varies greatly, from mild and self-limited to life-threatening. Between these extremes are gradations of obstruction that can be quantified. Testing airflow, along with the change in response to therapies or challenges (e.g. exercise, mannitol, methacholine), is useful when assessing and managing patients with asthma. This chapter deals with functional assessments of asthma in the pediatric patient, emphasizing tests that reflect airway and lung function. The primary focus is on studies that can be easily performed in an office or clinic setting, but tests that require more sophisticated equipment usually unavailable in these locations are also noted. Furthermore, because asthma often first presents in preschool children, tests of lung function that may be performed in the youngest patients are mentioned. Equipment necessary to measure pulmonary function in these young children typically exists only in centers with expertise in pediatric pulmonary medicine. However, knowledge of airway function close to the onset of disease is an important subject of ongoing investigations into the pathogenesis of the disorder, and newer techniques may be more amenable to widespread use in outpatient clinics.

A decline in airway function as measured by pulmonary function tests often reflects a change in airway structure; therefore, this chapter begins with an overview of the pathology of asthma. Greater detail on this subject can be found in other chapters. Appreciating the correlation between airway structure and function is important to clinical management. For example, understanding the pathologic findings in severe asthma helps

one to recognize components contributing to obstruction that are poorly responsive to acute treatment and take time to resolve. This will be reflected in tests of airway function soon after a patient is ill. Similarly, tests that define airway responsiveness may also correlate with lung pathology in subjects in whom the disease is clinically quiescent.

This chapter will also review how tests of lung function can help identify diseases that may mimic asthma and will consider the ways in which pulmonary function tests may help guide therapy in both acute and chronic conditions. Studies involving infants, children and adolescents are cited whenever possible. Investigations into structural and functional assessments of the disease in adults are cited when they provide additional insight into the process.

## The Pathology of Asthma

Fatal asthma is typified by marked airway inflammation with mucus and cellular debris, epithelial desquamation, subepithelial collagen deposition and airway wall thickening resulting in luminal obstruction.<sup>1-3</sup> Several factors contribute to airway wall thickening, including smooth muscle hypertrophy, edema, goblet cell hyperplasia and tissue infiltration by inflammatory cells. These features have been noted at autopsy, not only in adults but also in pediatric patients of varying ages.<sup>4</sup> Similar pathologic findings can be seen in biopsies from severe but nonfatal asthma.<sup>5</sup>

With the more recent use of bronchoalveolar lavage (BAL) and endobronchial biopsies to address asthma pathogenesis, it is apparent that airway inflammation is a hallmark of even clinically mild asthma.<sup>6,7</sup> Common features include infiltration of airways by eosinophils, activation of T cells within airways, increase in mast cell numbers and desquamation of airway epithelium.<sup>8</sup> These studies have been performed primarily in adults, with a loose correlation found between indices of inflammation and the level of airway responsiveness to provocative agents such as histamine and methacholine. Less information is available from pediatric patients, but work using BAL in older children and adolescents suggests that pathologic findings are similar to the abnormalities described in adults.<sup>9,10</sup> For example, Ferguson and colleagues<sup>10</sup> reported an association between the level of airway responsiveness to histamine and both eosinophil numbers and mast cell tryptase within BAL fluid of 6- to 16-year-old children. A more recent study found that, among preschool children with wheezing, increased airway smooth muscle present in endobronchial biopsy was associated with having asthma at school age.<sup>11</sup>

## The Physiology of Asthma

Asthma is defined by physiologic abnormalities. As noted earlier, these abnormalities include variable airflow limitation,

increased responsiveness of airways to provocation (i.e. bronchoconstriction) and improved airflow in response to bronchodilators (reversibility). Given these features and the common discrepancy between lung function and patient symptoms, asthma is a disease that is best quantified by objective testing. Several measures of lung mechanics have been used to describe asthma during both symptomatic and asymptomatic phases of the disease.<sup>12</sup> These measures include lung volumes, the pressure-volume characteristics of the lung, resistance to airflow and flow rates. A discussion of each of these measures in childhood asthma is presented, emphasizing flow rates and lung volumes as these are most commonly used by practicing physicians treating children.<sup>13</sup> Airway hyperresponsiveness, a fundamental feature of this disease, is also discussed.<sup>14,15</sup>

## SPIROMETRY

Spirometry is the most common technique used to assess pulmonary function. It is helpful to understand several key elements of spirometric assessment before discussing the role of this test in patient care. First, values obtained by spirometry are reported as absolute volume and, more importantly, in reference to that predicted for normal lung function based on the age, sex, height and race or ethnicity of the patient. Therefore, it is critical that these demographic factors are correctly noted and used. If spirometry test results are unexpectedly higher or lower than suggested by the history and examination, one is wise to double-check the accuracy of these demographic data. Second, the quality of both patient technique and effort will greatly affect spirometry data. Studies suggest that many tests performed in routine outpatient clinics are of suboptimal quality but that limited staff training can significantly improve this.<sup>16,17</sup> Most children can learn to perform spirometry tests with reasonable quality by the age of 5 to 7 years. Third, those interpreting spirometry tests should be properly trained. Physicians should be familiar with useful quality criteria that have been published by the American Thoracic Society/European Respiratory Society (ATS/ERS),<sup>18</sup> including forced expiratory time, repeatability and back extrapolated volume. However, data suggest that the clinical utility of spirometry data in children may depend more on the experience of the interpreter than on rigid numerical test parameters.<sup>19</sup> In other words, pediatric spirometry test results that do not meet published numerical quality standards are often still useful – especially when considered in the context of an individual patient.

Providers should also be aware of important efforts to improve spirometry interpretation. A notable international collaboration has recently produced the largest reference data set for spirometry to date. The Global Lung Function Initiative (GLI) reference equations include over 74,000 spirometric measurements from healthy, nonsmoking males and females aged 3 to 95 years, provided by over 70 organizations worldwide.<sup>20</sup> This includes spirometric indices from five ethnic groups and over 30,000 healthy young people between 2.5 and 18 years old. Using modern statistical techniques, these data have been used to generate the Quanjer GLI-2012 prediction equations, endorsed by all major respiratory societies and incorporated by manufacturers into many lung function devices. Ongoing efforts will contribute even greater representation of ethnic backgrounds into this reference data set, providing more reliable normal values across age and demographic characteristics. Also, many providers have moved to reporting data as Z-scores

rather than percent predicted of normal. A Z-score of  $-1.64$  represents the 5<sup>th</sup> percentile and has been proposed as a lower limit of normal for spirometry. Ninety-five percent of healthy subjects will fall within  $\pm 2$  Z-scores. Interpretation by lower limit of normal using Z-score is independent of age, height, sex and ethnic group, and may more clearly show how abnormal (i.e. far from the median) an individual's lung function is at the time of testing. Similar prevalence rates for impaired FEV<sub>1</sub>/FVC ratio and FEV<sub>1</sub> have been reported when transitioning from the familiar Hankinson and Wang equations to the GLI-2012.<sup>21–23</sup>

## Definitive Characteristics of Asthma

### A. AIRFLOW LIMITATION

The usual method of measuring the degree of airflow limitation is to assess lung function during a maximal forced exhalation.<sup>24</sup> The subject exhales forcibly from total lung capacity (TLC) to residual volume (RV) into either a spirometer or through a flow meter by which flow is integrated to give volume. The results are usually expressed as either a time-based recording of expired volume (spirogram) or a plot of instantaneous airflow against lung volume (maximal expiratory flow-volume [MEFV] curve). The tests of lung function derived from a spirogram are the forced vital capacity (FVC; TLC minus RV), the forced expiratory volume during the first second of exhalation (FEV<sub>1</sub>), and the forced expiratory flow from 25% to 75% of the FVC (FEF<sub>25–75</sub>). From the flow-volume curve, the maximal expiratory flow rate (MEFR) achieved approximates the peak expiratory flow rate (PEFR) obtained from a flow meter. Flow rates at and below 50% of the vital capacity (VC) are also obtained as part of this maneuver. Because airflow is related to lung volume, plethysmography combined with the MEFV maneuver plotted as a flow-volume curve or loop allows assessment of the relationship between airflow and absolute lung volumes (Figure 30-1). Measurement of flow rates in this manner may be informative when an isovolumetric shift occurs (discussed later). The effect of lung volume on airflow also highlights the importance of subject effort and technique.

In subjects with airflow obstruction due to asthma, the expected pattern of altered flow rates during an exacerbation can be predicted based on airway pathology and obstructive physiology. On spirometry, both the FEV<sub>1</sub> and FEF<sub>25–75</sub> are diminished, although the former is more preserved as a percent of predicted than the latter. Since the FVC is usually relatively preserved, the FEV<sub>1</sub>/FVC ratio is reduced. On the MEFV curve, the expiratory portion of the loop typically becomes concave, or 'scooped out' (see Figure 30-1) due to a greater impairment in flows at low lung volumes. These flows are the first to decrease and the last to return to normal. The MEFR, like its counterpart, the FEV<sub>1</sub>, is more preserved during acute attacks and is quicker to normalize.

In a minority of cases, the spirogram or MEFV curve alone will not reflect significant airway obstruction. However, if subjects are studied with both an MEFV maneuver and plethysmography to assess lung volumes, they will have a displacement of the flow-volume curve to a higher lung volume without a change in the configuration of the curve itself. Thus, if flow is measured as a percent of the VC, no change in flow is appreciated. However, when the same curve is plotted as a function of the absolute lung volumes present before and after onset of symptoms, substantial changes in flow become apparent at the

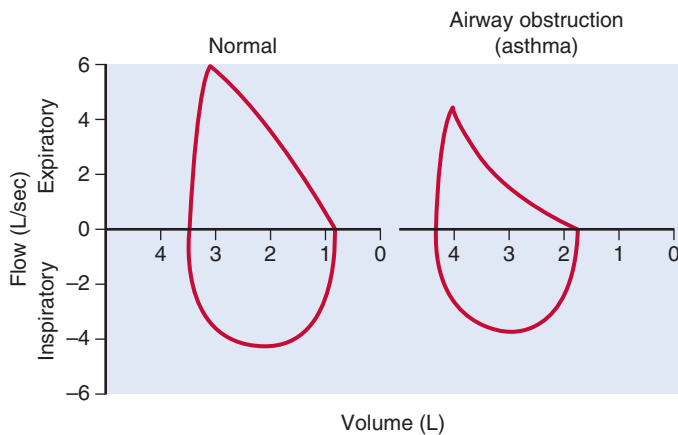

**Figure 30-1** Maximal inspiratory and expiratory curves that together constitute a flow-volume loop are shown in a patient with asthma when the disease is under control (*left loop*) and when control is lost (*right loop*). Flow is shown on the y-axis, whereas absolute lung volume is displayed on the x-axis. The point of maximal inspiration (TLC) is the point of zero flow on the left side of the loops while the point of maximal expiration (RV) is the point of zero flow at the right side of the loops. When asthma control is lost, hyperinflation is noted, with an increase in RV. In addition, expiratory flow rates decrease, as demonstrated in the maximal expiratory portion of the curve, which becomes concave. With milder instability, as shown in this example, the inspiratory portion of the loop is fairly well preserved. With more severe obstruction, inspiratory flows will be more compromised. (From Wenzel SE, Larsen GL. *Assessment of lung function: pulmonary function testing*. In: Bierman CW, Pearlman DS, Shapiro GS, Busse WW, editors. *Allergy, asthma, and immunology from infancy to adulthood*. 3rd ed. Philadelphia: WB Saunders; 1996.)

same lung volume, that is, at an isovolume. This represents an isovolumetric shift to a higher lung volume. The factors responsible for isovolumetric shifts are poorly defined but may include closure of some airways with loss of the contribution of these more obstructed units to the flow-volume pattern.

In acute asthma, loss of symptoms and signs of asthma does not mean that lung function has returned to normal. Classic studies by McFadden and colleagues<sup>25</sup> demonstrated that when patients with severe, acute asthma became asymptomatic, the overall mechanical function of their lungs in terms of the FEV<sub>1</sub> was still only 40% to 50% of predicted normal values. Thus loss of clinical signs of airway obstruction does not necessarily mean there has been physiologic recovery. This highlights the important role of measuring lung function when managing patients with asthma, especially those prone to severe airflow obstruction or those who have difficulty appreciating decline in lung function.

The use of peak flow meters within the home is an inexpensive method of monitoring a flow rate to assess asthma stability.<sup>26</sup> Although there are limitations, in that the PEF<sub>R</sub> may be normal while other spirometric indices are abnormal,<sup>27</sup> home monitoring of lung function can contribute to the care of selected patients. In this respect, significant changes in PEF<sub>R</sub> may be manifest before symptoms are evident, particularly in patients with limited recognition of early disease exacerbation. These devices may also be especially helpful in defining the presence and severity of nocturnal asthma.<sup>28</sup> The diurnal variation of PEF<sub>R</sub> (i.e. the difference between morning and evening measurements) is normally less than 10%. A PEF<sub>R</sub> variability of greater than 15% to 20% has been used as one defining

feature of nocturnal asthma. Patients with such variability should be regarded as having more severe asthma and inadequate disease control. Additionally, given that excessive diurnal variations in lung function during recovery from status asthmaticus have been associated with an increased risk of sudden death,<sup>29</sup> this vulnerable period of time may warrant close monitoring both in the hospital and home environment. Therefore, in more severe patients or those with limited recognition of signs and symptoms of exacerbation, monitoring the PEF<sub>R</sub> as part of their daily routine may allow for earlier recognition of loss of control with more timely intervention. Finally, it should be noted that the PEF<sub>R</sub> maneuver is technique- and effort-dependent with most home meters. This should be considered in younger patients and those who may have secondary gain with asthma-related illness.

## B. HEIGHTENED AIRWAY RESPONSIVENESS

Airway responsiveness is commonly defined as the ease with which airways narrow in response to various nonallergic and nonsensitizing stimuli, including inhaled pharmacologic agents (e.g. histamine, methacholine, mannitol) as well as natural physical stimuli (e.g. exercise, exposure to cold air). Heightened airway responsiveness to several stimuli causing bronchoconstriction and reduced airflow is a hallmark of asthma.<sup>14,15</sup> Even when conventional assessments of lung function are normal in children with chronic stable asthma, the airways often exhibit this heightened responsiveness. The most common method of quantifying airway responsiveness is to assess lung function (usually FEV<sub>1</sub>) before and after inhaling increasing concentrations of methacholine. The test is concluded when a defined decrease in lung function has been achieved; for the FEV<sub>1</sub>, this is usually a 20% decrease from baseline values. The more responsive the airways, the less methacholine is needed to decrease lung function. Exercise often increases FEV<sub>1</sub> in healthy patients, therefore a decrease of as little as 10% from baseline may reflect exercise-induced bronchoconstriction.

The level of airway responsiveness to pharmacologic agents has been noted to correlate roughly with the severity of disease in both adults and children.<sup>14,30,31</sup> Thus asthmatic subjects who are the most responsive are generally the most symptomatic (wheeze, cough, chest tightness) and require more medications to control their disease. Although there can be great variability in responsiveness within groups of patients classified by disease severity,<sup>32</sup> the concept that the level of responsiveness correlates with disease severity is important when considering factors that lead to loss of asthma control. In this respect, the level of airway responsiveness is not static in either normal individuals or asthmatic subjects but may increase or decrease in response to various stimuli. When responsiveness increases, control of the disease is often lost in that this is when asthmatic subjects develop signs and symptoms of their disease. In general, stimuli that increase responsiveness are found in our environment and induce or exacerbate airway inflammation. For children, these stimuli commonly include various viral respiratory infections, air pollutants (including cigarette smoke) and allergens.<sup>33</sup>

A viral respiratory infection is a common antecedent to acute episodes of asthma in children.<sup>34</sup> This has been documented for several respiratory viruses, including respiratory syncytial virus<sup>35</sup> and rhinovirus.<sup>36</sup> In terms of air pollutants, both nitrogen dioxide<sup>37</sup> and ozone<sup>38</sup> have been shown to enhance airway responsiveness. Cigarette smoke is arguably the most



serious environmental air pollutant in terms of the respiratory health of children and has been implicated in the onset as well as the perpetuation of the disease.<sup>39–41</sup> In addition, exposure of atopic individuals to relevant allergens can lead to significant increases in airway responsiveness that persist for days to months.<sup>42,43</sup> These classes of disease precipitants are often considered separately, but they assuredly have combined effects in an asthmatic subject's airways which contribute to disease instability.<sup>36</sup>

Just as airway responsiveness will increase in response to certain stimuli that lead to airway inflammation, the level of responsiveness will also decrease if measures are taken to decrease inflammation within airways.<sup>33</sup> These measures include use of medications with anti-inflammatory properties (e.g. inhaled corticosteroids), long-acting bronchodilators and the avoidance of relevant allergens (atopic asthmatic subjects) and cigarette smoke.<sup>15</sup>

### C. IMPROVED AIRFLOW IN RESPONSE TO BRONCHODILATORS

Increased pulmonary function, often measured by FEV<sub>1</sub> or FEV<sub>25–75</sub> and in response to short-acting bronchodilators such as inhaled  $\beta$ -agonists, is another defining feature of asthma. An increase in FEV<sub>1</sub> by 12% predicted or more is often used to define a significant response to bronchodilator medication. Greater improvement in FEF<sub>25–75</sub> is typically required (e.g. 25% predicted) and this more variable parameter is not used by all centers to determine response to bronchodilators. When testing response to other forms of inhaled bronchodilators it is important to understand the pharmacokinetics and predicted time needed for a medication to take effect.

### LUNG VOLUMES

During an exacerbation of asthma, all of the various capacities and volumes of gas contained in the lung may be altered to some extent. The RV, functional residual capacity (FRC) and TLC are usually increased (RV > FRC > TLC), whereas the VC and its subdivisions are decreased (see Figure 30-1). These alterations have been described during natural exacerbation of asthma in adults<sup>44</sup> and children.<sup>45</sup> Although laboratory induced changes in lung volumes (exercise, histamine challenge) may be immediately normalized with inhalation of a bronchodilator, it may take weeks after an episode of severe, acute asthma for the RV to return to a normal range.<sup>12</sup> The mechanisms responsible for the increases in RV, FRC (hyperinflation) and TLC (overdistension) are not completely understood. However, several factors have been identified that may contribute, including a generalized decrease in the elastic properties of the lung, a ball-valve phenomenon caused by swollen and mucus-plugged airways, and tonic activity in the intercostal muscles and diaphragm during episodes of obstruction.<sup>12</sup>

### ARTERIAL BLOOD GASES

The primary function of the lung is to provide for gas exchange such that oxygen is taken up and delivered to the body while carbon dioxide is eliminated. This function may be altered when control of asthma is lost. Several studies of acute asthma have correlated arterial blood gases with the level of airway obstruction. One of the classic descriptions is the work of

McFadden and Lyons.<sup>46</sup> These authors studied a large population (101 subjects) who, because of age (14 to 45 years) and medical history, were unlikely to have their asthma complicated by bronchitis and emphysema. This study and others (cited later) provide an important description of the expected abnormalities in gas exchange as a function of the degree of airway obstruction.

### Oxygen Tension

McFadden and Lyons<sup>46</sup> found that the characteristic blood gas pattern in patients who were experiencing acute asthma was hypoxemia associated with respiratory alkalosis. The hypoxemia was the most consistent abnormality found in their study. A near linear correlation was found between values of FEV<sub>1</sub> and arterial oxygen tension (Figure 30-2, top). Patients with an FEV<sub>1</sub> of 50% to 85% of their predicted normal values were arbitrarily classified as having mild airway obstruction; those with values of 26% to 50%, moderate obstruction; and those with values of less than 25%, severe obstruction. The mean values of arterial oxygen tension (in mm Hg as measured at sea level) ranked by disease severity were 82.8, 71.3 and 63.1, respectively. Thus there was almost a 20-mm Hg difference in arterial oxygen tensions between the mild and severe groups. Just as important, it was also noted that some degree of hypoxemia was encountered at all levels of airway obstruction. In terms of studies in children, Weng and colleagues<sup>47</sup> noted similar findings in asthmatic subjects who were 14 months to 14 years old. The study found that all symptomatic asthma patients were hypoxemic,

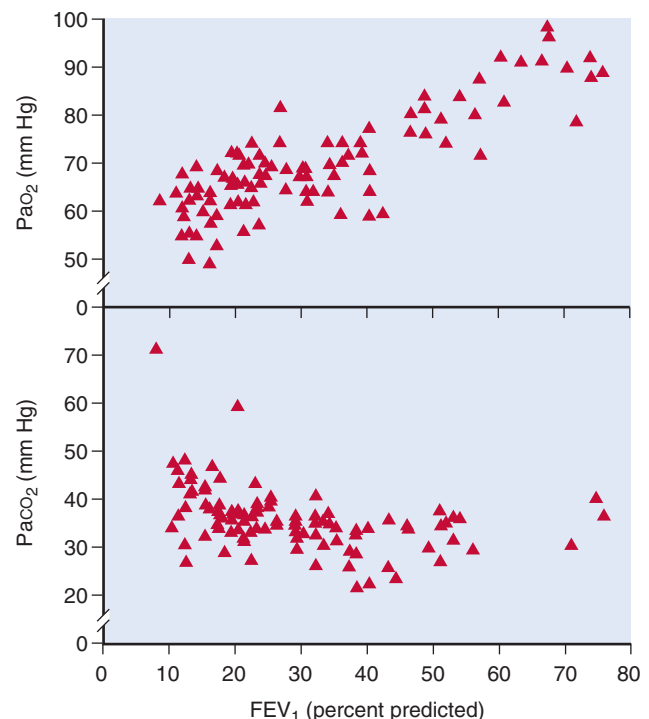

**Figure 30-2** The relationship between arterial oxygen (mm Hg) and degree of airway obstruction (FEV<sub>1</sub> as a percent of predicted) (top) and the relationship between arterial carbon dioxide (mm Hg) and FEV<sub>1</sub> (bottom). Although the level of hypoxemia correlates with the level of airway obstruction, an elevation in carbon dioxide levels is seen only when the FEV<sub>1</sub> is markedly compromised. (Data from McFadden ER Jr, Lyons HA. *N Engl J Med* 1968;278:1027–32.)

with the level of hypoxemia correlating with the degree of airflow obstruction.

Several mechanisms are likely to contribute to the hypoxemia just described. The primary mechanism is thought to be an alteration in ventilation-perfusion ratios.<sup>46,47</sup> For severely obstructed subjects, in whom atelectatic alveoli are still being perfused, transitory anatomic shunts may also contribute to the hypoxemia. In the most severely obstructed subjects, alveolar hypoventilation is also likely to be important.

The normal response of the body to a decrease in arterial oxygen is to increase ventilation. A reduced chemosensitivity to hypoxia coupled with a blunted perception of dyspnea may predispose patients to fatal asthma attacks. Kikuchi and colleagues<sup>48</sup> found that adult patients with a history of near-fatal asthma had respiratory responses to hypoxia that were significantly lower than responses in normal subjects and in asthmatic subjects without near-fatal attacks. The lower hypoxic response was seen in conjunction with a blunted perception of dyspnea. These abnormalities could occur because of preexisting genetic factors as well as adaptation of the body to recurrent hypoxia. The relative importance of these and other factors is unknown. Children with poor perception of airway obstruction may be at risk for fatal or near-fatal asthma.<sup>49</sup>

### Carbon Dioxide Tension

McFadden and Lyons<sup>46</sup> demonstrated that respiratory alkalosis often accompanies hypoxemia in asthmatic subjects experiencing exacerbations. In terms of carbon dioxide tensions, their study suggested that most attacks were associated with alveolar hypoventilation and that hypercapnia was not likely to occur until extreme degrees of obstruction were reached. Plotting airway obstruction (percent predicted FEV<sub>1</sub>) against the carbon dioxide tension indicated that hypercapnia was not seen until the FEV<sub>1</sub> fell to less than 20% of its predicted value (see [Figure 30-2, bottom](#)). Thus a 'normal' or elevated PaCO<sub>2</sub> in a patient with acute asthma is cause for concern.

### Arterial Values of pH

Arterial pH values in acute asthma typically reflect this respiratory alkalosis. In the study of McFadden and Lyons,<sup>46</sup> 73 of the 101 subjects had a respiratory alkalosis (mean pH 7.46); 21, normal pH; and 7, respiratory acidosis (mean pH 7.32). Weng and colleagues<sup>47</sup> reported similar results in children. A metabolic acidosis may also be seen in acute asthma. Although this is not commonly seen in adults, it has been noted in combination with a respiratory acidosis in children with severe asthma.<sup>47,50</sup> This acid-base imbalance is usually associated with very severe airway obstruction.<sup>51</sup> Although the mechanisms responsible for the metabolic acidosis remain to be clarified, we know that these subjects are in imminent danger of respiratory failure.<sup>47</sup>

## Functional Assessments of Asthma in Infants and Small Children

Assessment of lung function in a quantitative manner in infants and small children is very challenging. Noninvasive assessment of arterial oxygenation and gas exchange may be relatively straightforward, but measuring pulmonary mechanics, including airflow and lung volumes, is more problematic. Foremost among the problems encountered in working with

young subjects is that many are unable to cooperate in the performance of conventional respiratory maneuvers. There has been progress in addressing spirometric lung function in healthy preschool children,<sup>52</sup> but limits remain related to the age and developmental level of the child. Thus assessments in the youngest subjects must be done while they are sedated and asleep. In this respect, methods exist for assessing lung function in infants using spirometric techniques in which the patient is passive and forced exhaled flows are generated from near TLC to RV through rapid compression of the chest.<sup>53</sup> When this is accomplished, functional measures may be obtained that are similar to those in older children and adults. Although it is beyond the scope of this chapter to discuss in detail the methods that are used for these studies, it is important to point out that insight into normal maturation of airway function has been gained by this and similar approaches. For example, the highest flow rates corrected for lung size are found in newborns and healthy premature infants, with size-corrected flows decreasing to values found in older children and adults by the end of the first year of life.<sup>54</sup> In addition, normal infants bronchoconstrict when exposed to low concentrations of bronchoreactive agents such as methacholine<sup>55</sup> and histamine<sup>56</sup> as well as to the physical stimulus of cold, dry air.<sup>57</sup> Goldstein and colleagues<sup>58</sup> also found that the response in infants to the inhaled bronchodilator albuterol as assessed by forced expiratory flows was greatest in the youngest subjects. Montgomery and Tepper<sup>59</sup> demonstrated that normal infants and young children have a decrease in airway responsiveness to methacholine as they become older. Taken together, these studies suggest that an insult to an airway at a young age may interfere with this normal age-related decrease in responsiveness.

The onset of asthma is commonly during the early years of life. This has been noted in several studies, including work from Europe<sup>60</sup> as well as the USA.<sup>61,62</sup> Investigations of asthma often try to focus on disease pathogenesis closer to the time of onset. One practical consequence of this is that younger subjects must be assessed, given that the onset of disease is often in preschool children. In terms of quantitative assessments that help categorize disease severity as well as the effects of any intervention, measurements of lung function become essential. Groups have conducted longitudinal studies beginning in infancy and followed into childhood to phenotype young children based on the onset and persistence of wheeze, and atopy.<sup>63,64</sup> These and other similar studies help improve our understanding of asthma development but current prediction algorithms to identify asthma in individual school age children have modest diagnostic value.<sup>65</sup> Conventional methods to assess lung function in infants and preschool children are technically and logistically challenging when considering multicenter studies involving large numbers of subjects.<sup>66</sup> These measures are similarly impractical in the day-to-day care of young asthmatic subjects within many clinical settings. However, newer techniques offer promise when the assessment must be done in a time-effective manner in subjects with limited developmental ability to cooperate and concentrate on a particular task.

Forced oscillation is one of several more recent techniques that have been used to obtain lung function measures in young subjects.<sup>54,67,68</sup> This method involves the application of sine waves to the airway opening via a mouthpiece while the child breathes normally (tidal breathing). Several variables can be assessed, including resistance, reactance and resonant frequency of the respiratory system. Although use of this technique has

not been applied to large populations of children, published results demonstrate a reasonable agreement with more traditional measures of lung function.<sup>69</sup> This technique has been successfully used in young children with acute asthma<sup>70</sup> and has also been used to quantify the response to bronchoconstrictor and bronchodilator agents<sup>69,70</sup> in clinically stable asthmatic children.<sup>71,72</sup> Use of this approach is also feasible when assessing lung function responses to chronic therapy in very young<sup>73</sup> as well as older children with asthma.<sup>74,75</sup> Therefore, forced oscillation may prove useful in following the course of the disease.

Another more recent form of lung function assessment that can be used in awake preschool children is the lung clearance index (LCI). This is a measure of inhomogeneity in ventilation obtained by using the multiple-breath inert gas washout technique. LCI measurements are obtained during tidal breathing and have been used to detect airway disease in infants and children with cystic fibrosis.<sup>76,77</sup> How this technique may be useful in asthma management is yet to be established.

## Uses of Assessments of Lung Function

The preceding paragraphs have provided an overview of the tests of lung function that are commonly used to provide a functional assessment of asthma. Reference has been made to pathologic and physiologic correlates in the disease. This section is provided to address practical ways in which these functional assessments are commonly used. In this respect, we concentrate on lung function in diseases that may masquerade as asthma and therefore must be considered in the differential diagnosis of children with wheezing and other nonspecific pulmonary symptoms. We also address how these tests may be used to assess and follow asthma once that diagnosis has been established. In terms of the latter, the value of functional assessments during both acute and chronic phases of the disease is considered.

### FUNCTIONAL ASSESSMENTS OF DISEASES THAT MASQUERADE AS ASTHMA

Shortness of breath, cough, wheezing and chest tightness are not specific for asthma. Thus children who present in this manner may have other medical conditions. The differential diagnosis of wheezing and dyspnea in pediatric subjects is influenced by the age of the patient. The younger the child, the more one has to consider congenital problems involving the airways or cardiopulmonary system. This is especially true for infants and toddlers. In terms of older children and adolescents, the confounding conditions will be more analogous to the problems seen in adults. When considering the possible causes, an assessment of lung function will often help arrive at the correct diagnosis.

Children with bronchiolitis obliterans have experienced insults to their lungs (e.g. adenovirus infection, Stevens-Johnson syndrome with pulmonary involvement) that have led to scarring within small airways and severe airway obstruction.<sup>78</sup> They may present with dyspnea and/or wheezing, leading to the impression that they have asthma. On assessment of lung function, they demonstrate an obstructive pattern with evidence of hyperinflation and decreased expiratory flow rates. The same pattern is seen in other obstructive processes, including asthma

and cystic fibrosis. In bronchiolitis obliterans the correct diagnosis may be suggested by the lack of significant reversal of the airway obstruction with therapy that includes bronchodilators and/or corticosteroids, combined with other results such as lung imaging.

Pediatric patients with interstitial lung disease (ILD) may also present with a history of dyspnea and poor air exchange on physical examination.<sup>79,80</sup> These patients classically have an FEV<sub>1</sub> that is diminished, but the FVC is also reduced, and therefore the FEV<sub>1</sub>/FVC ratio is normal even before a bronchodilator is given. In addition, lung volumes are often decreased in ILD. This pattern is restrictive in nature compared with the obstructive pattern seen in asthma where total lung volume is normal or may be increased. The disease processes that lead to ILD are diverse. Because the causes and treatments, as well as the prognosis, are very different to those of asthma, it is critical to be able to recognize this pattern on assessment of lung function and to address the potential causes that lead to interstitial disease. A reduced FVC on spirometry suggests that total lung capacity may be decreased and should prompt consideration of lung volume testing (plethysmography). In children with asthma, it is also prudent to consider if poor technique or air trapping may be present and contributing to a low FVC.

Vocal cord dysfunction (VCD), a functional disorder of vocal cords that mimics attacks of asthma and/or upper airway obstruction, has received widespread attention.<sup>81,82</sup> Paroxysms of wheezing and dyspnea seen with VCD are refractory to standard therapy for asthma. During symptomatic episodes, the maximal expiratory and inspiratory flow-volume loop may resemble a variable extrathoracic obstruction (Figure 30-3). The diagnosis can be confirmed in a symptomatic subject by laryngoscopic examination, which demonstrates that the wheezing and/or stridor is associated with paradoxical adduction of the vocal cords during inspiration and sometimes during the entire respiratory cycle. Both the flow-volume loops and the laryngoscopic findings are completely normal when the subjects are asymptomatic. In the vast majority of patients VCD is subconscious and may be associated with stress. In pediatric patients as young as 4 years, underlying factors such as stress related to athletic or academic performance may be found.<sup>83-85</sup> It must be noted that VCD and asthma frequently co-exist in children.<sup>84</sup> Truncation of the inspiratory portion of the flow-volume loop together with a concave shape of the expiratory curve may then be found. Treatment of VCD is primarily accomplished through speech therapy together with psychotherapy in selected patients.<sup>82</sup> Conditions such as chronic post-nasal drip and gastroesophageal reflux may irritate the larynx and are also believed to contribute to VCD.<sup>86</sup> Although rarely needed, breathing a mixture of 70% helium/30% oxygen can relieve dyspnea and abort acute attacks.

Just as flow-volume loops may be helpful in making a diagnosis of VCD, they can also aid in the diagnosis of other types of obstructive lesions in the proximal airways (larynx and trachea) that may present with wheezing. For example, with a lesion that is circumferential, preventing either compression or dilation of the airway with respiratory efforts, a 'fixed' pattern is seen (see Figure 30-3) with truncation of both the inspiratory and expiratory curves. Subglottic stenosis and vascular rings that surround an airway might present with such a pattern. If a lesion permits compression or dilation with respiration, the pattern will depend on the location of the lesion (intrathoracic or extrathoracic). With an extrathoracic problem, a picture like

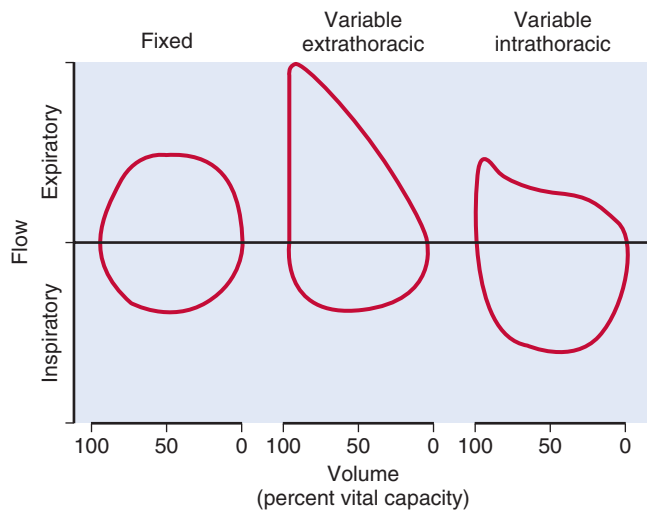

**Figure 30-3** Flow-volume loops are displayed for various types of obstructive lesions in the proximal airways (larynx and trachea) that may present with wheezing. For comparison, the normal contour of a flow-volume loop is shown (see left side of Figure 30-1). With a lesion that is circumferential, preventing either compression or dilation of the airway with respiratory efforts, a 'fixed' pattern is seen with truncation of both the inspiratory and expiratory curves. Subglottic stenosis and vascular rings that surround an airway might present with such a pattern. If a lesion permits compression or dilation with respiration, the pattern will depend on whether the lesion is intrathoracic or extrathoracic. With extrathoracic lesions (vocal cord dysfunction) (*middle*), the inspiratory curve is more affected. An intrathoracic lesion (mass that compresses only part of the airway, tracheomalacia) (*right*) will have more of an effect on expiratory flow rates. (From Wenzel SE, Larsen GL. *Assessment of lung function: pulmonary function testing*. In: Bierman CW, Pearlman DS, Shapiro GS, Busse WW, editors. *Allergy, asthma, and immunology from infancy to adulthood*. 3rd ed. Philadelphia: WB Saunders; 1996.)

that noted previously regarding VCD is seen. With an intrathoracic lesion, greater impairment of expiratory flow rates will be found.<sup>24</sup> One example of such an intrathoracic lesion is tracheomalacia.

## FUNCTIONAL ASSESSMENT OF ACUTE ASTHMA

The severity of acute asthma may be gauged by findings on physical examination, tests of lung function, and the adequacy of oxygenation and ventilation (oximetry, arterial blood gases). Pertinent findings on physical examination include use of the accessory muscles of respiration, particularly the sternocleidomastoid muscle, which is an indication of significant airflow obstruction.<sup>87</sup> The presence of a pulsus paradoxus of greater than 20 mm Hg is also a useful indicator of severe airflow limitation in children with acute asthma.<sup>88,89</sup> The finding of a 'quiet chest' in an anxious patient struggling to breathe is an ominous finding.

Although it is critical to recognize and appreciate the importance of these physical findings, quantitative assessments are also of great value in the patient with acute asthma. In asthmatic subjects who are extremely breathless, tests of lung mechanics, although highly desirable, may be difficult or impossible to obtain. Repeated spirometry alone may lead to greater airway obstruction in some children with moderate to severe acute asthma, precluding this manner of assessing the subject. When tests can be performed, assessments commonly include PEF<sub>R</sub> and FEV<sub>1</sub>. Flow rates on presentation are important, but a lack of improvement in lung function after initial treatment may be

a better predictor of the need for hospitalization than the pretreatment value.<sup>90</sup>

Oximetry has become the most widely applied and clinically useful tool for assessing oxygenation in emergent situations. Oximeters offer a rapid and reliable noninvasive method of assessing the most vital physiologic consequence of obstructed breathing. Physical signs of hypoxemia, such as irritability, pallor and cyanosis, are variable and may not be present at mild to moderate levels of oxygen desaturation. In children, oximetry provides a gauge of the acuity of their asthma and may be helpful in decision making regarding the need for hospitalization. In a study from Australia, Geelhoed and colleagues<sup>91</sup> found that the initial arterial oxygen saturation was highly predictive of outcome in pediatric asthma patients in an emergency department. A saturation of 91% was found to discriminate between favorable and unfavorable outcomes as defined in part by the need for subsequent care after the initial visit. In addition, continuous measurements of oxygen saturation during therapy allow care providers to quickly address fluctuations in oxygenation that may be the consequence of both the disease and the therapy provided to the patient. In terms of the latter, lung mechanics may improve after inhalation of a bronchodilator while oxygenation deteriorates.<sup>92</sup> This phenomenon is transient and has been attributed in part to the vasodilatory effect of the drugs on the pulmonary vessels, counteracting local vasoconstrictive factors in the lung and promoting 'mismatch' in lung ventilation and perfusion. Providers may be tempted to withhold additional bronchodilators when this occurs; however, these medications are necessary to expedite recovery and supplemental oxygen can be used as necessary to minimize hypoxemia while continuing acute treatment for asthma.

In instances when the episode is mild and the therapy is initiated early within the home environment, administration of bronchodilator treatment via metered dose inhaler or by nebulization may lead to substantial and prolonged bronchodilation. A good response is commonly defined as a return of the PEF<sub>R</sub> to greater than 80% of that predicted or personal best, with the response sustained for 4 hours.<sup>26</sup> Children who improve with home bronchodilator therapy may then safely repeat this treatment as frequently as every 4 hours. Serial measurements of peak flow before and after therapy are useful not only to assess the severity of acute asthma but also to monitor the response to treatment. A lack of response or an incomplete response to inhalation of a  $\beta_2$ -adrenergic agonist in a patient with asthma should always be a concern and is reason for evaluation and treatment by a physician.

## FUNCTIONAL ASSESSMENT OF CHRONIC ASTHMA

As noted earlier, airway obstruction may be present in children with asthma who are asymptomatic. In a subset of subjects who underappreciate or deny symptoms, the degree of obstruction can be quite remarkable. When this is encountered on a child's initial evaluation, the significance of the findings is difficult to assess. Therefore serial tests of lung function in subjects with chronic asthma will be helpful in several respects. First, when several determinations are made over time, the child's personal best lung functions are defined and serve as a point of reference for that child. Second, serial tests of lung function will help support the diagnosis of asthma if fluctuations in PEF<sub>R</sub> or FEV<sub>1</sub> are noted spontaneously or as a result of therapy. When little or



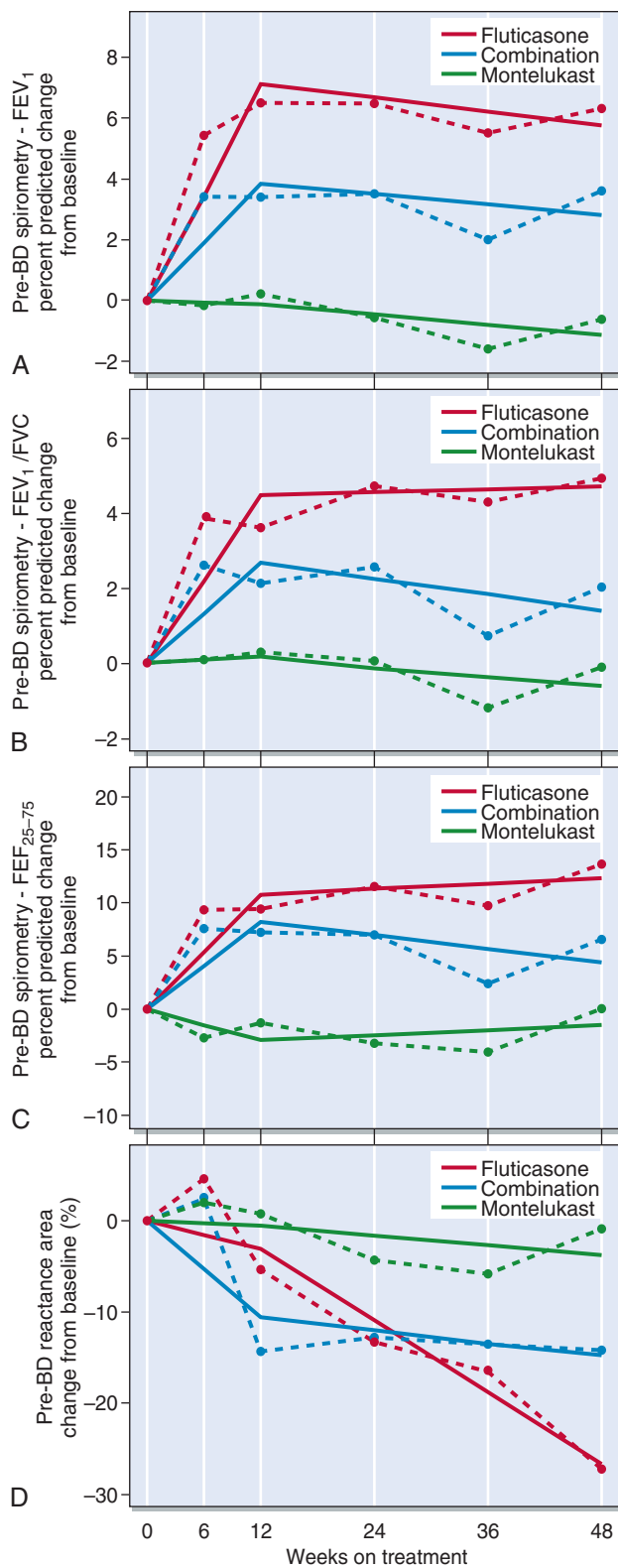

**Figure 30-4** Changes in FEV<sub>1</sub> (A), FEV<sub>1</sub>/FVC (B), FEF<sub>25-75</sub> (C) and XA (D) over time are shown for three treatment groups as both mean data at each measurement point (dashed lines) and as a regression model with a change point at 12 weeks of therapy (solid lines). During the first 12 weeks of therapy, the slopes of FEV<sub>1</sub>, FEV<sub>1</sub>/FVC and FEF<sub>25-75</sub> were significant in a positive direction for combination and fluticasone therapy. However, for these spirometric parameters, the pattern over the last period of therapy (12–48 weeks) was different, with all slopes close to zero (non-significant). Conversely, XA significantly improved in the fluticasone treatment group during the latter period, as reflected by the negative slope for change in XA. Pre-BD signifies measures were all performed before bronchodilator. (From Larsen GL, Morgan W, Heldt GP, Mauger DT, Boehmer SJ, Chinchilli VM, et al. *J Allergy Clin Immunol* 2009;123:860–7.)

no reversibility of lung function is found in the face of significant obstruction, other diseases such as bronchiolitis obliterans should be considered. Fourth, simple tests of lung function may help identify subjects with increased risk of future asthma attacks or those at greater risk for the persistence of respiratory symptoms.<sup>93,94</sup>

Serial tests of lung function also help define the effects of various approaches to therapy. This was demonstrated in a long-term study that compared three controller regimens.<sup>95</sup> Children aged 6 to 14 years with mild to moderate persistent asthma were characterized with both impulse oscillometry and spirometry before entry into a clinical trial and then serially during 48 weeks of therapy with either an inhaled corticosteroid, a combination inhaled corticosteroid with a long-acting  $\beta$ -agonist, or a leukotriene receptor antagonist. The spirometric parameters FEV<sub>1</sub>, FEV<sub>1</sub>/FVC and FEF<sub>25-75</sub> all demonstrated significant improvement during the first 12 weeks of therapy in the groups receiving corticosteroid and combination therapy. However, improvement appeared to plateau at that time with improvement maintained but not increasing during the latter part of therapy (12 to 48 weeks). Conversely, reactance area (XA), a measurement obtained with oscillometry that reflects both reactance and resonant frequency, demonstrated improvement during the latter part of the study in the corticosteroid treatment arm of the trial. These changes with treatment over time are shown in Figure 30-4. Studies such as this demonstrate not only the time course and magnitude of effects that may be expected with different approaches to therapy, but also suggest that information from oscillometry and spirometry may differ and be complementary.

## Conclusions

Asthma is characterized by increased responsiveness of airways to various stimuli, variable airflow limitation and reversible airway obstruction (see Key Points). Given these features, quantitative tests of lung function are useful tools in both diagnosis and management. During acute episodes of asthma, marked decreases in flow rates together with hyperinflation of the lungs are seen in tests of lung mechanics. In addition, hypoxemia is a common finding in subjects with wheezing, whereas hypercapnia develops as a late consequence of severe airflow obstruction. In many patients, clinical signs and symptoms of obstruction resolve long before tests of lung function normalize. In a subgroup of asthmatic patients, lung function will never completely normalize. Serial tests of lung function help define a child's

personal best lung function values, help support the diagnosis of asthma, give clues to alternate diagnoses and complicating problems, and help identify subjects with increased risk of future asthma instability. Serial tests of lung function also help define the effects of various approaches to therapy. A fundamental knowledge of the pathophysiology of acute and chronic asthma is necessary to fully interpret functional studies and to provide effective treatment for patients with this common yet potentially life-threatening condition.

## KEY REFERENCES

16. Eaton T, Withy S, Garrett JE, Mercer J, Whitlock RM, Rea HH. Spirometry in primary care practice: the importance of quality assurance and the impact of spirometry workshops. *Chest* 1999;116:416–23.
20. Quanjer PH, Stanojevic S, Cole TJ, Baur X, Hall GL, Culver BH, et al. Multi-ethnic reference values for spirometry for the 3–95-yr age range: the global lung function 2012 equations. *Eur Respir J* 2012;40:1324–43.
25. McFadden ER Jr, Kiser R, DeGroot WJ. Acute bronchial asthma. Relations between clinical and physiologic manifestations. *N Engl J Med* 1973;288:221–5.
33. Larsen GL. Asthma in children. *N Engl J Med* 1992;326:1540–5.
34. Rakes GP, Arruda E, Ingram JM, Hoover GE, Zambrano JC, Hayden FG, et al. Rhinovirus and respiratory syncytial virus in wheezing children requiring emergency care. IgE and eosinophil analyses. *Am J Respir Crit Care Med* 1999;159:785–90.
36. Lemanske RF Jr, Dick EC, Swenson CA, Vrtis RF, Busse WW. Rhinovirus upper respiratory infection increases airway hyperreactivity and late asthmatic reactions. *J Clin Invest* 1989;83:1–10.
63. Martinez FD, Wright AL, Taussig LM, Holberg CJ, Halonen M, Morgan WJ. Asthma and wheezing in the first six years of life. The Group Health Medical Associates. *N Engl J Med* 1995;332:133–8.
64. Collins SA, Pike KC, Inskip HM, Godfrey KM, Roberts G, Holloway JW, et al. Validation of novel wheeze phenotypes using longitudinal airway function and atopic sensitization data in the first 6 years of life: evidence from the Southampton Women's survey. *Pediatr Pulmonol* 2013;48:683–92.
73. Guilbert TW, Morgan WJ, Zeiger RS, Mauer DT, Boehmer SJ, Szeffler SJ, et al. Long-term inhaled corticosteroids in preschool children at high risk for asthma. *N Engl J Med* 2006;354:1985–97.
82. Davis RS, Brugman SM, Larsen GL. Use of videography in the diagnosis of exercise-induced vocal cord dysfunction: a case report with video clips. *J Allergy Clin Immunol* 2007;119:1329–31.

## Acknowledgments

We acknowledge the significant contribution to previous editions of this chapter by Dr Gary L. Larsen, MD, many of which are incorporated in the current edition.

The complete reference list can be found on the companion Expert Consult website at <http://www.expertconsult.inkling.com>.



## REFERENCES

- Dunnill MS, Massarella GR, Anderson JA. A comparison of the quantitative anatomy of the bronchi in normal subjects, in status asthmaticus, in chronic bronchitis, and in emphysema. *Thorax* 1969;24:176–9.
- Dunnill MS. The pathology of asthma, with special reference to changes in the bronchial mucosa. *J Clin Pathol* 1960;13:27–33.
- Persson CG. Centennial notions of asthma as an eosinophilic, desquamative, exudative, and steroid-sensitive disease. *Lancet* 1997;350:1021–4.
- Richards W, Patrick JR. Death from asthma in children. *Am J Dis Child* 1965;110:4–23.
- Cutz E, Levison H, Cooper DM. Ultrastructure of airways in children with asthma. *Histopathology* 1978;2:407–21.
- Beasley R, Roche WR, Roberts JA, Holgate ST. Cellular events in the bronchi in mild asthma and after bronchial provocation. *Am Rev Respir Dis* 1989;139:806–17.
- Vignola AM, Chanez P, Campbell AM, Souques F, Lebel B, Enander I, et al. Airway inflammation in mild intermittent and in persistent asthma. *Am J Respir Crit Care Med* 1998;157:403–9.
- Djukanovic R, Roche WR, Wilson JW, Beasley CR, Twentyman OP, Howarth RH, et al. Mucosal inflammation in asthma. *Am Rev Respir Dis* 1990;142:434–57.
- Ferguson AC, Wong FW. Bronchial hyperresponsiveness in asthmatic children. Correlation with macrophages and eosinophils in bronchoalveolar fluid. *Chest* 1989;96:988–91.
- Ferguson AC, Whitelaw M, Brown H. Correlation of bronchial eosinophil and mast cell activation with bronchial hyperresponsiveness in children with asthma. *J Allergy Clin Immunol* 1992;90(4 Pt 1):609–13.
- O'Reilly R, Ullmann N, Irving S, Bossley CJ, Sonnappa S, Zhu J, et al. Increased airway smooth muscle in preschool wheezers who have asthma at school age. *J Allergy Clin Immunol* 2013;131:1024–32, 1032 e1–16.
- Wagers SSJE, Irvin CG. Development, structure, and physiology in normal and asthmatic lung. In: Adkinson NFYJ Jr, Busse WW, et al., editors. *Middleton's allergy: principles and practice*. 6th ed. St. Louis: Mosby; 2003.
- Larsen GL, Brugman SM. Severe asthma in children. In: Barnes PJGM, Leff A, editors. *Asthma*. Philadelphia: Lippincott-Raven; 1997.
- Hargreave FE, Dolovich J, O'Byrne PM, Ramsdale EH, Daniel EE. The origin of airway hyperresponsiveness. *J Allergy Clin Immunol* 1986;78(5 Pt 1):825–32.
- Colasurdo GN, Larsen GL. Airway hyperresponsiveness. In: Busse WWS, editor. *Asthma and rhinitis*. 2nd ed. London: Blackwell Science; 2000.
- Eaton T, Withy S, Garrett JE, Mercer J, Whitlock RM, Rea HH. Spirometry in primary care practice: the importance of quality assurance and the impact of spirometry workshops. *Chest* 1999;116:416–23.
- Licskai CJ, Sands TW, Paolatto L, Nicoletti I, Ferrone M. Spirometry in primary care: an analysis of spirometry test quality in a regional primary care asthma program. *Can Respir J* 2012;19:249–54.
- Beydon N, Davis SD, Lombardi E, Allen JL, Arets HG, Aurora P, et al. An official American Thoracic Society/European Respiratory Society statement: pulmonary function testing in preschool children. *Am J Respir Crit Care Med* 2007;175:1304–45.
- Muller-Brandes C, Kramer U, Gappa M, Seitner-Sorge G, Huls A, von Berg A, et al. LUNOKID: can numerical American Thoracic Society/European Respiratory Society quality criteria replace visual inspection of spirometry? *Eur Respir J* 2014;43:1347–56.
- Quanjer PH, Stanojevic S, Cole TJ, Baur X, Hall GL, Culver BH, et al. Multi-ethnic reference values for spirometry for the 3–95-yr age range: the global lung function 2012 equations. *Eur Respir J* 2012;40:1324–43.
- Quanjer PH, Weiner DJ. Interpretative consequences of adopting the Global Lungs 2012 reference equations for spirometry for children and adolescents. *Pediatr Pulmonol* 2014;49:118–25.
- Wang X, Dockery DW, Wypij D, Fay ME, Ferris BG Jr. Pulmonary function between 6 and 18 years of age. *Pediatr Pulmonol* 1993;15:75–88.
- Hankinson JL, Odencrantz JR, Fedan KB. Spirometric reference values from a sample of the general U.S. population. *Am J Respir Crit Care Med* 1999;159:179–87.
- Wenzel SE, Larsen GL. Assessment of lung function: pulmonary function testing. In: Bierman CW, Pearlman DS, Shapiro GS, editors. *Allergy, asthma, and immunology from infancy to adulthood*. 3rd ed. Philadelphia: WB Saunders; 1996.
- McFadden ER Jr, Kiser R, DeGroot WJ. Acute bronchial asthma. Relations between clinical and physiologic manifestations. *N Engl J Med* 1973;288:221–5.
- National Asthma E, Prevention P. Expert Panel Report 3 (EPR-3): guidelines for the diagnosis and management of asthma – Summary Report 2007. *J Allergy Clin Immunol* 2007;120(Suppl. 5):S94–138.
- Bye MR, Kerstein D, Barsh E. The importance of spirometry in the assessment of childhood asthma. *Am J Dis Child* 1992;146:977–8.
- Martin RJ. Nocturnal asthma. *Clin Chest Med* 1992;13:533–50.
- Hetzel MR, Clark TJ, Branthwaite MA. Asthma: analysis of sudden deaths and ventilatory arrests in hospital. *Br Med J* 1977;1:808–11.
- Murray AB, Ferguson AC, Morrison B. Airway responsiveness to histamine as a test for overall severity of asthma in children. *J Allergy Clin Immunol* 1981;68:119–24.
- Avital A, Noviski N, Bar-Yishay E, Springer C, Levy M, Godfrey S. Nonspecific bronchial reactivity in asthmatic children depends on severity but not on age. *Am Rev Respir Dis* 1991;144:36–8.
- Amaro-Galvez R, McLaughlin FJ, Levison H, Rashed N, Galdes-Sebaldo M, Zimmerman B. Grading severity and treatment requirements to control symptoms in asthmatic children and their relationship with airway hyperreactivity to methacholine. *Ann Allergy* 1987;59:298–302.
- Larsen GL. Asthma in children. *N Engl J Med* 1992;326:1540–5.
- Rakes GP, Arruda E, Ingram JM, Hoover GE, Zambrano JC, Hayden FG, et al. Rhinovirus and respiratory syncytial virus in wheezing children requiring emergency care. IgE and eosinophil analyses. *Am J Respir Crit Care Med* 1999;159:785–90.
- Hall WJ, Hall CB, Speers DM. Respiratory syncytial virus infection in adults: clinical, virologic, and serial pulmonary function studies. *Ann Intern Med* 1978;88:203–5.
- Lemanske RF Jr, Dick EC, Swenson CA, Vrtis RF, Busse WW. Rhinovirus upper respiratory infection increases airway hyperreactivity and late asthmatic reactions. *J Clin Invest* 1989;83:1–10.
- Bauer MA, Utell MJ, Morrow PE, Speers DM, Gibb FR. Inhalation of 0.30 ppm nitrogen dioxide potentiates exercise-induced bronchospasm in asthmatics. *Am Rev Respir Dis* 1986;134:1203–8.
- Zwick H, Popp W, Wagner C, Reiser K, Schmoeger J, Bock A, et al. Effects of ozone on the respiratory health, allergic sensitization, and cellular immune system in children. *Am Rev Respir Dis* 1991;144:1075–9.
- Martinez FD, Antognoni G, Macri F, Bonci E, Midulla F, De Castro G, et al. Parental smoking enhances bronchial responsiveness in nine-year-old children. *Am Rev Respir Dis* 1988;138:518–23.
- Fielder HM, Lyons RA, Heaven M, Morgan H, Govier P, Hooper M. Effect of environmental tobacco smoke on peak flow variability. *Arch Dis Child* 1999;80:253–6.
- Burr ML, Anderson HR, Austin JB, Harkins LS, Kaur B, Strachan DP, et al. Respiratory symptoms and home environment in children: a national survey. *Thorax* 1999;54:27–32.
- Boulet LP, Cartier A, Thomson NC, Roberts RS, Dolovich J, Hargreave FE. Asthma and increases in nonallergic bronchial responsiveness from seasonal pollen exposure. *J Allergy Clin Immunol* 1983;71:399–406.
- Mussaffi H, Springer C, Godfrey S. Increased bronchial responsiveness to exercise and histamine after allergen challenge in children with asthma. *J Allergy Clin Immunol* 1986;77(1 Pt 1):48–52.
- Woolcock AJ, Read J. Lung volumes in exacerbations of asthma. *Am J Med* 1966;41:259–73.
- Weng TR, Levison H. Pulmonary function in children with asthma at acute attack and symptom-free status. *Am Rev Respir Dis* 1969;99:719–28.
- McFadden ER Jr, Lyons HA. Arterial-blood gas tension in asthma. *N Engl J Med* 1968;278:1027–32.
- Weng TR, Langer HM, Featherby EA, Levison H. Arterial blood gas tensions and acid-base balance in symptomatic and asymptomatic asthma in childhood. *Am Rev Respir Dis* 1970;101:274–82.
- Kikuchi Y, Okabe S, Tamura G, Hida W, Homma M, Shirato K, et al. Chemosensitivity and perception of dyspnea in patients with a history of near-fatal asthma. *N Engl J Med* 1994;330:1329–34.
- Baker RR, Mishoe SC, Zaitoun FH, Arant CB, Lucas J, Rupp NT. Poor perception of airway obstruction in children with asthma. *J Asthma* 2000;37:613–24.
- Downes JJ, Wood DW, Striker TW, Pittman JC. Arterial blood gas and acid-base disorders in infants and children with status asthmaticus. *Pediatrics* 1968;42:238–49.
- Appel D, Rubenstein R, Schragger K, Williams MH Jr. Lactic acidosis in severe asthma. *Am J Med* 1983;75:580–4.

52. Eigen H, Bieler H, Grant D, Christoph K, Terrill D, Heilman DK, et al. Spirometric pulmonary function in healthy preschool children. *Am J Respir Crit Care Med* 2001;163(3 Pt 1):619–23.
53. Jones M, Castile R, Davis S, Kisling J, Filbrun D, Flucke R, et al. Forced expiratory flows and volumes in infants. Normative data and lung growth. *Am J Respir Crit Care Med* 2000;161(2 Pt 1):353–9.
54. Martinez FD, Morgan WJ, Wright AL, Holberg C, Taussig LM. Initial airway function is a risk factor for recurrent wheezing respiratory illnesses during the first three years of life. *Group Health Medical Associates. Am Rev Respir Dis* 1991;143:312–16.
55. Tepper RS. Airway reactivity in infants: a positive response to methacholine and metaproterenol. *J Appl Physiol* 1987;62:1155–9.
56. LeSouef PN, Geelhoed GC, Turner DJ, Morgan SE, Landau LI. Response of normal infants to inhaled histamine. *Am Rev Respir Dis* 1989;139:62–6.
57. Geller DE, Morgan WJ, Cota KA, Wright AL, Taussig LM. Airway responsiveness to cold, dry air in normal infants. *Pediatr Pulmonol* 1988;4:90–7.
58. Goldstein AB, Castile RG, Davis SD, Filbrun DA, Flucke RL, McCoy KS, et al. Bronchodilator responsiveness in normal infants and young children. *Am J Respir Crit Care Med* 2001;164:447–54.
59. Montgomery GL, Tepper RS. Changes in airway reactivity with age in normal infants and young children. *Am Rev Respir Dis* 1990;142(6 Pt 1):1372–6.
60. Croner S, Kjellman NI. Natural history of bronchial asthma in childhood. A prospective study from birth up to 12–14 years of age. *Allergy* 1992;47(2 Pt 2):150–7.
61. Yunginger JW, Reed CE, O'Connell EJ, Melton LJ 3rd, O'Fallon WM, Silverstein MD. A community-based study of the epidemiology of asthma. Incidence rates, 1964–1983. *Am Rev Respir Dis* 1992;146:888–94.
62. Halonen M, Stern DA, Lohman C, Wright AL, Brown MA, Martinez FD. Two subphenotypes of childhood asthma that differ in maternal and paternal influences on asthma risk. *Am J Respir Crit Care Med* 1999;160:564–70.
63. Martinez FD, Wright AL, Taussig LM, Holberg CJ, Halonen M, Morgan WJ. Asthma and wheezing in the first six years of life. *The Group Health Medical Associates. N Engl J Med* 1995;332:133–8.
64. Collins SA, Pike KC, Inskip HM, Godfrey KM, Roberts G, Holloway JW, et al. Validation of novel wheeze phenotypes using longitudinal airway function and atopic sensitization data in the first 6 years of life: evidence from the Southampton Women's survey. *Pediatr Pulmonol* 2013;48:683–92.
65. Bousquet J, Gern JE, Martinez FD, Anto JM, Johnson CC, Holt PG, et al. Birth cohorts in asthma and allergic diseases: Report of a NIAID/NHLBI/MeDALL joint workshop. *J Allergy Clin Immunol* 2014;133:1535–46.
66. Peterson-Carmichael SL, Rosenfeld M, Ascher SB, Hornik CP, Arets HG, Davis SD, et al. Survey of clinical infant lung function testing practices. *Pediatr Pulmonol* 2014;49:126–31.
67. Desager KN, Marchal F, van de Woestijne KP. Forced oscillation technique. In: Stocks J, Sly PD, Tepper RS, Morgan WJ, editors. *Infant respiratory function testing*. New York: Wiley-Liss; 1996.
68. Larsen GL, Kang JK, Guilbert T, Morgan W. Assessing respiratory function in young children: developmental considerations. *J Allergy Clin Immunol* 2005;115:657–66, quiz 67.
69. Duiverman EJ, Neijens HJ, Van der Snee-van Smaalen M, Kerrebijn KF. Comparison of forced oscillometry and forced expirations for measuring dose-related responses to inhaled methacholine in asthmatic children. *Bull Eur Physiopathol Respir* 1986;22:433–6.
70. Klug B, Bisgaard H. Measurement of lung function in awake 2–4-year-old asthmatic children during methacholine challenge and acute asthma: a comparison of the impulse oscillation technique, the interrupter technique, and transcutaneous measurement of oxygen versus whole-body plethysmography. *Pediatr Pulmonol* 1996;21:290–300.
71. Komarow HD, Skinner J, Young M, Gaskins D, Nelson C, Gergen PJ, et al. A study of the use of impulse oscillometry in the evaluation of children with asthma: analysis of lung parameters, order effect, and utility compared with spirometry. *Pediatr Pulmonol* 2012;47:18–26.
72. Hellinckx J, De Boeck K, Bande-Knops J, van der Poel M, Demedts M. Bronchodilator response in 3–6.5 years old healthy and stable asthmatic children. *Eur Respir J* 1998;12:438–43.
73. Guilbert TW, Morgan WJ, Zeiger RS, Mauger DT, Boehmer SJ, Szeffler SJ, et al. Long-term inhaled corticosteroids in preschool children at high risk for asthma. *N Engl J Med* 2006;354:1985–97.
74. Shi Y, Aledia AS, Galant SP, George SC. Peripheral airway impairment measured by oscillometry predicts loss of asthma control in children. *J Allergy Clin Immunol* 2013;131:718–23.
75. Shi Y, Aledia AS, Tatavoosian AV, Vijayalakshmi S, Galant SP, George SC. Relating small airways to asthma control by using impulse oscillometry in children. *J Allergy Clin Immunol* 2012;129:671–8.
76. Lum S, Gustafsson P, Ljungberg H, Hulskamp G, Bush A, Carr SB, et al. Early detection of cystic fibrosis lung disease: multiple-breath washout versus raised volume tests. *Thorax* 2007;62:341–7.
77. Amin R, Subbarao P, Jabar A, Balkovec S, Jensen R, Kerrigan S, et al. Hypertonic saline improves the LCI in paediatric patients with CF with normal lung function. *Thorax* 2010;65:379–83.
78. Kurland G, Michelson P. Bronchiolitis obliterans in children. *Pediatr Pulmonol* 2005;39:193–208.
79. Fan LL, Mullen AL, Brugman SM, Inscore SC, Parks DP, White CW. Clinical spectrum of chronic interstitial lung disease in children. *J Pediatr* 1992;121:867–72.
80. Fan LL, Detering RR, Langston C. Pediatric interstitial lung disease revisited. *Pediatr Pulmonol* 2004;38:369–78.
81. Christopher KL, Wood RP 2nd, Eckert RC, Blager FB, Raney RA, Souhrada JF. Vocal-cord dysfunction presenting as asthma. *N Engl J Med* 1983;308:1566–70.
82. Davis RS, Brugman SM, Larsen GL. Use of videography in the diagnosis of exercise-induced vocal cord dysfunction: a case report with video clips. *J Allergy Clin Immunol* 2007;119:1329–31.
83. O'Connell MA, Sklarew PR, Goodman DL. Spectrum of presentation of paradoxical vocal cord motion in ambulatory patients. *Ann Allergy Asthma Immunol* 1995;74:341–4.
84. Gavin LA, Wamboldt M, Brugman S, Roesler TA, Wamboldt F. Psychological and family characteristics of adolescents with vocal cord dysfunction. *J Asthma* 1998;35:409–17.
85. Powell DM, Karanfilov BI, Beechler KB, Treole K, Trudeau MD, Forrest LA. Paradoxical vocal cord dysfunction in juveniles. *Arch Otolaryngol Head Neck Surg* 2000;126:29–34.
86. Balkissoon R, Kenn K. Asthma: vocal cord dysfunction (VCD) and other dysfunctional breathing disorders. *Semin Respir Crit Care Med* 2012;33:595–605.
87. Commey JO, Levison H. Physical signs in childhood asthma. *Pediatrics* 1976;58:537–41.
88. Galant SP, Groncy CE, Shaw KC. The value of pulsus paradoxus in assessing the child with status asthmaticus. *Pediatrics* 1978;61:46–51.
89. Martell JA, Lopez JG, Harker JE. Pulsus paradoxus in acute asthma in children. *J Asthma* 1992;29:349–52.
90. Schuh S, Johnson D, Stephens D, Callahan S, Canny G. Hospitalization patterns in severe acute asthma in children. *Pediatr Pulmonol* 1997;23:184–92.
91. Geelhoed GC, Landau LI, LeSouef PN. Predictive value of oxygen saturation in emergency evaluation of asthmatic children. *BMJ* 1988;297:395–6.
92. Holmgren D, Sixt R. Effects of salbutamol inhalations on transcutaneous blood gases in children during the acute asthmatic attack: from acute deterioration to recovery. *Acta Paediatr* 1994;83:515–19.
93. Bahceciler NN, Barlan IB, Nuhoglu Y, Basaran MM. Risk factors for the persistence of respiratory symptoms in childhood asthma. *Ann Allergy Asthma Immunol* 2001;86:449–55.
94. Fuhlbrigge AL, Kitch BT, Paltiel AD, Kuntz KM, Neumann PJ, Dockery DW, et al. FEV(1) is associated with risk of asthma attacks in a pediatric population. *J Allergy Clin Immunol* 2001;107:61–7.
95. Larsen GL, Morgan W, Heldt GP, Mauger DT, Boehmer SJ, Chinchilli VM, et al. Impulse oscillometry versus spirometry in a long-term study of controller therapy for pediatric asthma. *J Allergy Clin Immunol* 2009;123:861–7, e1.



# Infections and Asthma: Impact on the Natural History of Asthma

DANIEL J. JACKSON | ROBERT F. LEMANSKE, JR. | JAMES E. GERN

## KEY POINTS

- Wheezing viral respiratory illnesses are the most common initial presentation of childhood asthma.
- Once asthma is established, viral infections, most notably rhinovirus (RV), are the most frequent trigger of severe asthma exacerbations. RV-C appears to be a particularly pathogenic virus in children with asthma.
- Evidence has recently emerged to suggest that bacterial pathogens in the lower airway may contribute to the expression of asthma. Ongoing studies are critical to our understanding of the role of the airway microbiome in asthma inception and exacerbation.
- Synergistic interactions between underlying allergy and virus infections play an important mechanistic role in asthma inception and exacerbation, and are an important therapeutic target.
- Novel therapies are needed to prevent and treat virus-induced wheezing and asthma exacerbations.

## Introduction

Respiratory infections can cause wheezing illnesses in children of all ages and also influence the development and severity of asthma in several ways. First, viral wheezing episodes during infancy are a critical risk factor for asthma inception. Once asthma is established, viral upper respiratory tract infections (URTIs) are the most common trigger for acute exacerbations. Furthermore, a potential role for particular bacterial pathogens in the development of wheezing and asthma exacerbations has been identified. This chapter will review the relationships between infections and asthma inception and exacerbation. Additionally, we discuss mechanisms by which infections lead to lower respiratory inflammation and airway dysfunction. Finally, we discuss treatment strategies for virus-induced wheezing and exacerbations of asthma.

## Relationships Between Early Life Infections and Childhood Asthma

### VIRUSES

Viral respiratory illnesses leading to wheezing are one of the most common causes of hospitalization during infancy. Using multiple virus detection methods, including polymerase chain reaction (PCR), Jartti and colleagues<sup>1</sup> investigated the etiology of wheezing illness in 293 hospitalized children. Of the 76 infants with virus detected, 54% had respiratory syncytial virus (RSV),

42% had picornaviruses (human rhinovirus [RV] and enterovirus) and 1% had human metapneumovirus (hMPV). In older children, respiratory picornaviruses, most commonly RV, dominated (65% of children aged 1 to 2 years and 82% of children aged  $\geq 3$  years). Outpatient wheezing illnesses are also extremely common in young children, and viruses have been implicated in 67% to 90% of these episodes in different populations.<sup>2,3</sup>

Wheezing with viruses during infancy is often an early manifestation of asthma. Several large, long-term prospective studies of children have demonstrated that RSV bronchiolitis is a significant independent risk factor for recurrent wheezing and asthma, at least within the first decade of life.<sup>4,5</sup> A recent clinical trial comparing palivizumab (anti-RSV monoclonal antibody) to placebo in near preterm infants demonstrated reductions in recurrent wheezing during the first year of life in the children treated with palivizumab.<sup>6</sup> This is the strongest level of evidence to date in support of a causal role for RSV in recurrent wheezing. However, a longitudinal, population-based cohort study has demonstrated that the association between RSV lower respiratory infections during early life and both frequent (more than three episodes) and infrequent wheezing (less than three episodes) decreases with age and becomes nonsignificant by the age of 13 years.<sup>4</sup> These data suggest that although RSV infections contribute substantially to the risk of recurrent wheezing and asthma in early childhood, other co-factors (e.g. genetic, environmental, developmental) also contribute to the expression of asthma or modification of phenotypes over time. Interestingly, a 2013 study identified unique immune response profiles during and after RSV bronchiolitis in comparison with bronchiolitis caused by other viruses.<sup>7</sup>

With the development of molecular diagnostics, significant evidence has emerged to suggest that wheezing illnesses caused by RV identify children at highest risk for childhood asthma.<sup>2,8</sup> The Childhood Origins of ASThma (COAST) birth cohort study confirmed prior associations between RSV wheezing in the first 3 years of life and childhood asthma, but demonstrated that RV wheezing during this time is associated with a greater, 10-fold increased risk of childhood asthma.<sup>2</sup> Mechanisms by which recurrent RV infections may lead to wheezing and airway remodeling, particularly in susceptible hosts, have been described.<sup>9</sup> A new species of RV, RV-C, was recently discovered,<sup>10,11</sup> and has been shown to be an important cause of lower respiratory illnesses and wheezing in children.<sup>12-14</sup> A longitudinal analysis within the COAST study demonstrated that both RV-A and RV-C were more likely than RV-B to cause moderate-to-severe respiratory illnesses in infants.<sup>15</sup> Whether RV-C wheezing illnesses confer a greater risk of childhood asthma development is currently unknown.

Molecular diagnostics are not universally available to clinicians, so the question of whether season of wheezing is helpful

in delineating risk is an important one. Bronchiolitis during infancy is associated with an approximately 2-fold increased risk of early childhood asthma; however, this risk differs by season of bronchiolitis. Bronchiolitis occurring during RV-predominant months (spring and fall) was associated with an estimated 25% increased risk of early childhood asthma compared with RSV-predominant (winter) months. However, the proportion of associated asthma after winter season bronchiolitis is greater than RV-predominant months because of higher rates of bronchiolitis during the RSV season.<sup>16</sup> Season of birth also appears relevant: children born close to the onset of the winter virus season are most prone to the development of lower respiratory tract symptoms, and this is likely due to a developmental component in relationship to the timing of the winter virus peak.<sup>17,18</sup>

## BACTERIA

It has been proposed that chronic bacterial infections or colonization with pathogenic bacteria could initiate chronic lower airway inflammation, impaired mucociliary clearance, increased mucus production and ultimately asthma.<sup>19,20</sup> Organisms primarily implicated in this process include *Chlamydia pneumoniae*,<sup>21–23</sup> *Mycoplasma pneumoniae*,<sup>24,25</sup> *Streptococcus pneumoniae*, *Haemophilus influenzae* and *Moraxella catarrhalis*.<sup>20</sup> Studies of chronic mycobacterial or *Chlamydia pneumoniae* infection and asthma in children have yielded conflicting results, potentially in part due to the limitations of current diagnostics. Findings of diagnostic tests in the upper and lower airways are not always concurrent, and diagnosis of infection by serology leads to inaccuracies. The role of these bacteria in acute wheezing in young children is also unclear.

Recent publications have suggested that pathogenic bacteria may play a role in both acute wheezing episodes and asthma inception in preschool children. First, Bisgaard and colleagues found that neonates with *S. pneumoniae*, *H. influenzae* or *M. catarrhalis*, or with a combination of these organisms, in their hypopharynx are at increased risk for recurrent wheeze early in life and the diagnosis of asthma at the age of 5 years.<sup>20</sup> This original observation was made in infants of mothers with asthma, but the researchers were able to replicate some of these findings in an unselected cohort.<sup>26</sup> Further, these pathogens have been detected at higher rates in preschool children during acute wheezing episodes.<sup>27</sup> Interestingly, a similar predominance of Proteobacteria has been identified in the airways of older children and adults with established asthma.<sup>28,29</sup> Furthermore, in both human and animal studies, environmental exposure to 'protective' bacteria appears to have the capacity to prevent the development of wheezing and/or asthma in young children.<sup>30–33</sup> These studies of the role of microbial exposures and the microbiome in asthma inception are intriguing, and additional studies are a high priority to establish causality/protection and the specificity of these observations to asthma pathogenesis, and to define immunoinflammatory mechanisms contributing to these associations in both pediatric and adult patients.

## Infections and Acute Exacerbations of Asthma

The relationship between viral infections and exacerbations of asthma has been clarified by the development of molecular

diagnostic tests for viruses that are difficult to culture: RV, hMPV and bocaviruses. With the advent of these more sensitive diagnostic tools, information linking common cold infections with exacerbations of asthma has come from a number of sources. Prospective studies of children with asthma have demonstrated that up to 85% of exacerbations of wheezing or asthma in children are associated with viral infections.<sup>34</sup> Although many respiratory viruses can provoke acute asthma symptoms, RVs are most often detected, especially during the spring and fall RV seasons. In fact, the spring and fall peaks in hospitalizations because of asthma closely coincide with patterns of RV isolation within the community.<sup>35</sup> RV infections, most commonly RV-C, are frequently detected in children who present to emergency departments with acute wheezing and in children hospitalized for acute asthma.<sup>12,14,36</sup> Influenza and RSV are somewhat more likely to trigger acute asthma symptoms in the winter but appear to account for a smaller fraction of total asthma flares. Other viruses that are less frequently associated with wheezing and exacerbations of asthma include bocavirus,<sup>37</sup> metapneumovirus<sup>38</sup> and coronaviruses.<sup>39</sup> Together, these studies provide evidence of a strong relationship between viral infections, particularly those associated with RV, and acute exacerbations of asthma.

It is interesting that individuals with asthma do not necessarily have more colds, but have greater lower respiratory tract symptoms associated with colds. A prospective study of colds in couples consisting of one asthmatic and one healthy individual demonstrated that colds cause greater duration and severity of lower respiratory symptoms in patients with asthma.<sup>40</sup> These findings suggest that asthma is associated with fundamental differences in the lower airway manifestations of respiratory viral infections. In addition to provoking asthma, RV infections can increase lower airway obstruction in individuals with other chronic airway diseases such as chronic obstructive pulmonary disease<sup>41</sup> and cystic fibrosis.<sup>42</sup> Thus, common cold viruses that produce relatively mild illnesses in most people can cause severe pulmonary problems in susceptible individuals.

The role of respiratory viruses in exacerbations is particularly important in light of recent observations that severe asthma exacerbations may lead to progressive loss of lung function over time.<sup>43,44</sup> As seen in other chronic lung diseases, a paradigm by which recurrent severe exacerbations lead to progressive loss of lung function and enhanced disease severity over time appears to be emerging in asthma.

## Sinus Infections and Asthma

The nature of the association between asthma and sinusitis in children (and adults) has been the subject of debate for many years. Much of the difficulty in defining this relationship results from the uncertainties in making the clinical diagnosis of sinusitis, because the signs and symptoms of sinusitis in children overlap with many common childhood respiratory disorders, including the common cold, allergic rhinitis and asthma. As reviewed in Chapter 26, untreated sinus disease may contribute to unstable asthma control in some patients. Because bacterial infections are clearly involved in acute and chronic sinus disease, the mechanisms by which these microbes may promote hyper-reactivity in the lower airway have been of great interest. These relationships are covered in depth elsewhere in this text and therefore are not further reviewed in this chapter.

## Mechanisms of Infection-Induced Wheezing Illnesses

Clinical studies and in vitro studies have provided a number of insights into the pathogenesis of virus-induced wheezing illnesses and exacerbations of asthma (Box 31-1).

### SPREAD OF INFECTION FROM THE UPPER TO THE LOWER AIRWAYS

Respiratory viruses such as RSV and influenza are well known to infect the lower airway, and both can cause bronchitis, bronchiolitis and pneumonia. RV has traditionally been considered to be an upper airway pathogen because of its association with common cold symptoms and the observation that it replicates best at 33–35°C, which approximates to temperatures in the upper airway. In fact, lower airway temperatures are conducive to RV replication down to fourth-generation bronchi and exceed 35°C only in the periphery of the lung.<sup>45</sup> Moreover, some RV types, including RV-C isolates, replicate equally well at 33 and 37°C.<sup>46,47</sup> RV appears to replicate equally well in cultured epithelial cells derived from either upper or lower airway epithelium.<sup>48</sup> Finally, RV has been detected in lower airway cells and secretions by several techniques after experimental inoculation.<sup>49–51</sup> Titers of infectious virus in lower sputum reach or exceed those found in nasal secretions in some individuals.<sup>50</sup> In addition to evidence from experimental infection models, RV is frequently detected in infants and children with lower respiratory signs and symptoms, including children hospitalized for pneumonia.<sup>52,53</sup> Collectively, these findings suggest that respiratory viruses, including RV, can cause wheezing illnesses and exacerbations of asthma mainly by infecting lower airways and causing or amplifying lower airway inflammation.

### VIRUS-INDUCED CYTOPATHIC EFFECTS

First, viral infections damage airway epithelial cells and can cause airway edema and leakage of serum proteins into the airway. These effects, together with shedding of infected cells into the airway, can lead to obstruction and wheezing. In addition, viral infections stimulate mucus secretion and can also promote the formation of additional goblet cells (mucoid metaplasia) that can enhance mucus secretion that can persist even after the acute infection has resolved. Virus-induced injury to the epithelium can disrupt airway physiology through a number of different pathways (Box 31-2). For example, viral infections

can increase the permeability of the epithelium,<sup>54</sup> which may facilitate contact of irritants and allergens with immune cells, leave neural elements exposed and promote secondary infection with bacterial pathogens. In addition, the combination of epithelial edema and sloughing together with mucus production can lead to airway obstruction and wheezing.

As reviewed under ‘Viruses’, there is clinical evidence that the RV-B species may be less virulent than other RVs. Moreover, there is corresponding evidence from in vitro studies that RV-B viruses replicate more slowly, produce less cytopathic effect and induce lower interferon and inflammatory responses compared to other RVs.<sup>55</sup> Overall, these viruses appear to be attenuated.

### ROLE OF ANTIVIRAL IMMUNE RESPONSES

Virus-induced immune responses are necessary to clear the viral infection but they can also contribute to airway dysfunction and symptoms by causing an influx of inflammatory cells that adversely affect lower airway physiology. Antiviral immune responses are initiated within the epithelial cell and amplified by resident and recruited leukocytes in the airway. For viruses such as RV that infect relatively few cells in the airway, virus-induced inflammation may be the primary mechanism for the pathogenesis of respiratory symptoms and lower airway dysfunction.<sup>56</sup> Viral respiratory infections can also induce the synthesis of many of the factors that regulate airway and alveolar development and remodeling, including vascular endothelial growth factor (VEGF), nitric oxide (NO), metalloproteinases and fibroblast growth factor (FGF).<sup>57–60</sup> How single or repeated bouts of virus-induced overexpression of these regulators of lung development and remodeling affect the ultimate lung structure and function is not known, but they could exert long-term effects on lung function and asthma following viral infection in infancy.

#### *Epithelial Cells*

The processes associated with viral replication trigger innate immune responses within the epithelial cell. Virus attachment to cell surface receptors can initiate some immune responses. For example, RSV infection activates signaling pathways in airway epithelial cells through the innate immune system through Toll-like receptor (TLR)-4.<sup>61</sup> Furthermore, the development of oxidative stress during viral infections can activate epithelial cell responses. Inside the cell, viral RNA is detected by innate immune sensors on endosomal surfaces (TLR-3, TLR-7, TLR-8) and intracellular proteins, such as the dsRNA-dependent

#### BOX 31-1 KEY CONCEPTS

##### Proposed Mechanisms of Virus-Induced Wheezing

- Viral infection spreads from the upper to the lower airway
- Virus-induced damage to airway epithelium
- Airway edema and transudation of serum proteins
- Mucus hypersecretion
- Cellular inflammation: mononuclear cells and neutrophils
- Neuroinflammation
- Enhanced airway responsiveness
- Interactions between respiratory viral infections and preexisting airway inflammation
- Secondary bacterial infection

#### BOX 31-2 KEY CONCEPTS

##### Role of the Epithelium in Virus-Related Inflammation and Injury Pathogenesis

- Airway epithelial cells serve as hosts for viral replication
- Viral replication initiates the immune response to virus
- Interferon secretion to inhibit inflammation and injury of neighboring cells
- Chemokine secretion to recruit leukocytes into the airway
- Virus-induced epithelial cell damage can disrupt barrier function
- Viral infection induces mucus secretion and mucous metaplasia

protein kinase (PKR) and retinoic acid-inducible gene I (RIG-I), to activate the innate antiviral immune response.<sup>62</sup> Through these pathways, viral replication stimulates antiviral effector molecules such as RNase L, and inhibition of protein synthesis within infected cells. In addition, innate antiviral responses induce chemokines (e.g. CXCL10) that recruit inflammatory cells into the airway and type I (IFN- $\alpha$  and IFN- $\beta$ ) and type III (IFN- $\lambda$ 1 and IFN- $\lambda$ 2) interferons that have autocrine and paracrine antiviral effects.

### Leukocytes

Respiratory viruses activate monocytes, macrophages and dendritic cells to secrete an array of proinflammatory cytokines such as IL-1, IL-8, IL-10, tumor necrosis factor (TNF)- $\alpha$  and IFN- $\gamma$ . In animal models, respiratory viral infections lead to a prominent expansion of mature dendritic cells in the lung.<sup>63</sup> Significantly, pulmonary dendritic cells express high levels of Toll-like receptors, and secrete large amounts of interferons in response to viral infection. Dendritic cell interferon responses are impaired in early life, which likely contributes to increased susceptibility to viral infections in infancy.<sup>64</sup>

Acute respiratory viral infections are often accompanied by pronounced neutrophilia of upper and lower respiratory secretions, and products of neutrophil activation contribute to airway obstruction and lower airway symptoms. For example, neutrophil elastase can up-regulate goblet cell secretion of mucus.<sup>65</sup> P2X7 is a cation channel expressed by leukocytes and airway epithelial cells that is important to pathogen control and neutrophilic inflammation. Attenuated P2X7 function, which is common in mild to moderate asthma, is associated with reduced recruitment of neutrophils to the airway during RV colds, and an increased risk of acute asthma symptoms.<sup>66</sup>

Lymphocytes are recruited into the upper and lower airways during the early stages of a viral respiratory infection, and it is presumed that these cells help to limit the extent of infection and to clear virus-infected epithelial cells. This is consistent with reports of severe viral lower respiratory infections in immunocompromised patients.<sup>67</sup> B cell responses to respiratory viruses also serve to limit duration and severity of illness, as indicated by the finding of frequent and prolonged viral illnesses in patients with X-linked agammaglobulinemia.<sup>68</sup>

### Neuroinflammatory Mechanisms

Viral respiratory infections can induce inflammation through mechanisms involving neural mechanisms. These responses are difficult to study in humans, but studies in animal models have provided insights. For example, RSV infection in rodents leads to overproduction of nerve growth factor,<sup>69</sup> which promotes airway inflammation. This observation has also been confirmed in studies of babies with RSV bronchiolitis.<sup>70</sup> In a guinea pig model, virus infection causes dysfunction of M2 muscarinic receptors on parasympathetic nerves, leading to overproduction of acetylcholine and airway hyperresponsiveness. These responses appear to be driven by virus-induced acute phase cytokines such as IL-1 $\beta$  and TNF- $\alpha$ .<sup>71</sup>

### Mediators

Mediators that are produced in excess during respiratory illnesses include NO, leukotrienes, prostaglandins, kinins and oxidative metabolites,<sup>72-74</sup> and inhibition of specific mediators can ameliorate some cold symptoms.<sup>75</sup> Histamine does not appear to play a role in common cold pathogenesis.<sup>76</sup>

## RELATIONSHIP OF CELLULAR ANTIVIRAL RESPONSES TO OUTCOME OF VIRAL INFECTIONS

Several studies have tested the hypothesis that individual variations in cellular immune responses and patterns of cytokine production are related to the outcome of respiratory infections. In clinical studies, reduced IFN- $\gamma$  responses of blood mononuclear cells *ex vivo* are associated with a significant increase in viral respiratory illnesses during infancy.<sup>77-79</sup> In addition, several studies have found that asthma is associated with impaired virus-induced secretion of interferons by airway and peripheral blood cells.<sup>80-83</sup> Together, these experimental findings suggest that individual variability in the cellular immune response to respiratory viruses, and interferon responses in particular, can influence the clinical and virologic outcomes of infection.

## INTERACTIONS WITH BACTERIA

It is well established that viral illnesses of the middle ear, sinuses and lungs can promote secondary infections with bacterial pathogens such as *S. pneumoniae*, *M. catarrhalis*, and *H. influenzae*. As reviewed under 'Bacteria', colonization with these bacteria in early childhood is also a risk factor for acute wheezing episodes and asthma.<sup>20</sup> In school-aged children, these pathogens are more likely to be detected in association with a viral infection or just after a viral infection.<sup>84</sup> Furthermore, the risk of illness vs asymptomatic infection was greater in children who had both viruses and bacteria detected. Similarly, for children with asthma, moderate exacerbations were most likely to occur in viral infections in which *S. pneumoniae* or *M. catarrhalis* were also detected.<sup>84</sup> These findings suggest that viruses and bacteria may work together to promote airway pathology and respiratory symptoms.

## ENVIRONMENTAL FACTORS AND VIRAL ILLNESSES

Environmental factors strongly influence the probability of exacerbations and appear to act together with viral infections in an additive fashion. As discussed in the next section, allergy is a strong risk factor for the development of asthma after virus-induced wheezing episodes in infancy and is also closely associated with virus-induced exacerbations of asthma in older children and adults with asthma. Accordingly, the combination of allergy and exposure to a relevant allergen contributes to virus-induced exacerbations of asthma.<sup>85</sup> Similarly, exposure to greater levels of air pollutants such as NO<sub>2</sub> and SO<sub>2</sub> also enhances the risk of virus-induced exacerbation.<sup>86,87</sup>

## Interactions Between Allergy and Infections

Allergic sensitization has been defined as a clear risk factor for the development of asthma.<sup>88</sup> Children with 'multiple early sensitization' to aeroallergens have been identified as a phenotype at particularly high risk for asthma inception and severe exacerbations leading to hospitalization.<sup>89</sup> A sequential relationship whereby allergic sensitization precedes viral wheezing, most notably with RV, has been described.<sup>90</sup> Furthermore, children



who develop both risk factors in early life are at highest risk for subsequent asthma.<sup>2,91</sup>

There is convincing evidence to implicate respiratory allergy as a risk factor for wheezing with common cold infections later on in childhood. In studies conducted in an emergency department, risk factors for developing acute wheezing episodes were determined.<sup>85,92,93</sup> Individual risk factors for developing wheezing included detection of a respiratory virus, most commonly RV, positive allergen-specific IgE and presence of eosinophilic inflammation. Notably, viral infections and allergic inflammation synergistically enhanced the risk of wheezing, and higher levels of allergen-specific IgE conferred the greatest risk. This synergism may be particularly notable for RV-C.<sup>14</sup>

There are multiple mechanisms by which viral infections are thought to interact with allergic inflammation in order to lead to airway dysfunction, wheezing and asthma exacerbations.<sup>94</sup> First, viral infections can damage the barrier function of the airway epithelium, leading to enhanced absorption of aeroallergens across the airway wall and enhanced inflammation, while allergic inflammation may also lead to enhanced viral replication.<sup>95,96</sup> Next, allergic inflammation enhances airway responsiveness to RV.<sup>97</sup> There is also significant evidence that allergic asthmatic individuals have impaired antiviral responses as noted above. Furthermore, allergen exposure and high-affinity IgE receptor cross-linking has been shown to impair virus-induced type I and III interferon production in peripheral blood cells.<sup>98,99</sup> This may lead to both enhanced viral replication and also type 2 inflammation.<sup>100,101</sup>

## Treatment of Infection-Induced Wheezing and Asthma

### VIRUS-INDUCED WHEEZING IN INFANCY

Acute lower respiratory tract illnesses during the first one to two years of life are usually termed 'bronchiolitis' and are most likely due to infection with viral respiratory pathogens. The efficacy of various interventions for the treatment of the acute lower airway symptoms of wheezing, tachypnea, retractions and hypoxemia that occur as a result of these infections has been controversial due to variations in study design, the inability to rapidly and conveniently measure pulmonary physiologic variables, the confounding of results by the inclusion of children with a history of multiple wheezing episodes (i.e. asthmatic phenotypes) and the choice of outcome measures that have been evaluated.<sup>102</sup> In a recent series of meta-analyses evaluating various therapies, the routine use of bronchodilators,<sup>103</sup> steam or nebulized normal saline,<sup>104,105</sup> anticholinergics<sup>106</sup> and steroids<sup>107</sup> has not been shown to be of consistent benefit.

A more recent study suggests that the timing of the administration of epinephrine may influence the observed benefit. In an eight-center randomized, double-blind trial with a two-by-two factorial design, investigators compared inhaled racemic epinephrine with inhaled saline and on-demand inhalation with fixed-schedule inhalation (up to every 2 hours) in infants (>12 months of age) with moderate-to-severe acute bronchiolitis.<sup>108</sup> Length of stay, use of oxygen supplementation, nasogastric tube feeding, ventilatory support and relative improvement in the clinical score from baseline (preinhalation) were similar in the infants treated with inhaled racemic epinephrine and those treated with inhaled saline. However, the strategy of

inhalation on demand was superior to that of inhalation on a fixed schedule for many of the outcome measures evaluated.

The atopic background of the patient (eczema or asthma in a first-degree relative) may influence the response to oral corticosteroid administration. Infants aged  $\leq 18$  months presenting to a care facility for treatment of moderate-to-severe bronchiolitis and who had a positive history of eczema or were known to have a parent or a full sibling with a prior physician diagnosis of asthma were treated with oral dexamethasone, 1 mg/kg, then 0.6 mg/kg for 4 more days, or matching placebo. All patients received albuterol nebulization delivered through a tight-fitting face mask with pressurized oxygen. Dexamethasone plus albuterol treatment shortened time to readiness for discharge from the unit. However, there was no difference between the treatment groups in terms of inpatient and clinic visits during the week following discharge.<sup>109</sup>

### VIRUS-INDUCED WHEEZING IN PRESCHOOL CHILDREN

Therapeutic approaches for virus-induced wheezing in preschool children (ages 2–5 years) are challenging due to the fact that many children only wheeze with the 'common cold' and are totally asymptomatic in between these episodes, while others may have symptoms more or less on a daily basis as well. In addition, these episodes may range in severity from mild wheezing and coughing to severe respiratory distress that requires prompt medical intervention. Standard therapy for virus-induced wheezing in young children generally includes a stepwise addition of medications, typically commencing with a bronchodilator. If lower respiratory tract symptoms become increasingly severe or respiratory distress develops, oral corticosteroids are often added. Recent clinical trials in the management of these wheezing episodes also have included the use of high-dose inhaled corticosteroids (both prophylactically and/or as an acute intervention) and leukotriene receptor antagonists.

### THE ROLE OF ORAL CORTICOSTEROIDS IN ACUTE EXACERBATIONS OF ASTHMA IN YOUNG CHILDREN

Numerous studies have been undertaken to assess the role of corticosteroid therapy in acute episodes of asthma in children and adults.<sup>110</sup> Meta-analyses of these studies support the early use of systemic corticosteroids in acute exacerbations based upon a reduction in the admission rate for asthma and prevention of relapse in the outpatient treatment of exacerbations.<sup>111,112</sup> As a reflection of such information, the most recent National Heart, Lung, and Blood Institute (NHLBI) Guidelines for the Diagnosis and Management of Asthma recommend the addition of corticosteroids for asthma exacerbations unresponsive to bronchodilators; in contrast to previous versions of these guidelines, doubling the dose of inhaled corticosteroids to prevent further progression of the airway obstruction is not recommended.<sup>113</sup>

Unfortunately, the applicability of these recommendations to young children and infants whose acute wheezing episode is primarily related to viral respiratory tract infections has not been as thoroughly examined. Moreover, in studies that have been conducted in this age group, the results are conflicting.<sup>114–118</sup> Limitations of these studies include inclusion of multiple

wheezing phenotypes,<sup>116,118</sup> relatively small sample sizes, poor adherence to study medication and protocol in the outpatient studies,<sup>115,118</sup> and episodes of relatively mild severity in both outpatient and inpatient studies.<sup>115,118</sup> A recent randomized, double-blind, placebo-controlled trial compared a 5-day course of oral prednisolone (10 mg once a day for children 10–24 months of age and 20 mg once a day for older children for a total of 5 days) with placebo in over 650 children between the ages of 10 months and 60 months. The primary outcome, the duration of hospitalization, was no different between the treatment groups.<sup>116</sup> An accompanying editorial for this published study challenged the clinical research community to conduct additional prospective trials to clearly establish the efficacy of oral corticosteroid treatment of these ‘asthma-like’ episodes in preschool children.<sup>119</sup>

To address these concerns further, the Childhood Asthma Research and Education (CARE) network investigated whether oral corticosteroids reduced symptom scores during acute lower respiratory tract illnesses (LRTIs) in preschool children with recurrent wheeze. The investigators performed post hoc and replication analyses in two outpatient cohorts of children<sup>120,121</sup> aged 1 to 5 years with episodic wheezing that had participated in previous CARE-conducted studies.<sup>122</sup> Comparisons were made of symptom scores during LRTIs that were or were not treated with oral corticosteroids, adjusting for differences in disease and episode severity. The primary outcome was the area under the curve of total symptom scores among the more severe episodes. In both of the two cohorts studied independently, oral corticosteroid treatment did not reduce symptom severity during acute LRTIs. Moreover, subgroups of children who might have been more likely to experience benefit, such as those with asthma risk factors (positive modified asthma predictive index,<sup>123</sup> personal eczema and/or family history of asthma), did not appear to have a greater benefit than those without such characteristics. The investigators emphasized, however, that these results were hypothesis generating and needed to be confirmed in randomized prospective studies.<sup>124</sup> Taken together, however, these studies indicate that acute asthma-like episodes of airway obstruction in preschool children appear to respond less well to oral corticosteroid administration than do similar episodes in older children and adults.

### THE ROLE OF INHALED CORTICOSTEROIDS IN THE PREVENTION AND TREATMENT OF ACUTE WHEEZING EXACERBATIONS

The CARE network conducted a 3-year prospective trial in preschool children, all of whom had a modified positive asthma predictive index.<sup>125</sup> The overall goal of the study was to determine if early recognition and treatment of children who were at increased risk of developing childhood asthma could prevent the disease process from expressing itself and, further, if it could reduce losses of lung function that have been described during the first six years of life in children who develop persistent wheezing by age 3 years.<sup>126</sup> Children, 2 to 4 years of age, were randomized to receive either fluticasone propionate 88 µg twice daily or matching placebo using a valved spacer with mask. Treatment was for 2 years followed by a 1-year observation period off all study medication. The primary outcome measure was episode-free days. During the active treatment phase, children receiving inhaled corticosteroid (ICS) had a significantly increased number of episode-free days. In addition, they had

significant reductions in oral corticosteroid-requiring exacerbations (37% reduction) and less use of a prespecified step-up plan. Pulmonary function was also significantly better at the end of the treatment period in those children who had received ICS for the previous two years. Unfortunately, about three months into the observation period, there was no longer any significant difference in any of these outcome measures and at the end of the observation period (1 year later), pulmonary function was also no different between the two groups.<sup>127</sup> These data indicate that continuous therapy with ICS in preschool children at high risk of developing asthma reduces lower respiratory tract exacerbations that are most frequently caused by respiratory pathogens in this age group.

Many preschool children wheeze only with respiratory tract pathogens and are asymptomatic between these episodes. Therefore, a 1-year randomized, double-blind comparison among intermittent treatment with high-dose ICS, a leukotriene receptor antagonist (montelukast) and scheduled albuterol (so-called ‘standard of care’) was conducted in preschool children with histories consistent with this type of respiratory pattern.<sup>120</sup> Therapy was initiated by the family, based on the participant achieving a symptom profile threshold that the child had exhibited in the past that would usually foreshadow the development of more significant lower airway involvement. After 1 year of treatment, the three groups did not differ in proportions of episode-free days (primary outcome), oral corticosteroid use, healthcare utilization, quality of life or linear growth. However, during respiratory tract illnesses, both ICS and montelukast therapy led to modest reductions in trouble breathing and interference with activity scores compared to those children only treated with albuterol. These differences were significant only in those children with a positive asthma predictive index prior to enrollment. In a post hoc analysis, similar findings were obtained when the cohort was stratified by oral corticosteroid use (0 vs ≥ 1 course) during the year preceding participation in the trial.

The observations that both the continuous<sup>127</sup> and intermittent<sup>120</sup> use of ICS had an effect on both the frequency and severity of exacerbations that were most likely related to a concomitant viral or bacterial respiratory tract illness provided the impetus for a third CARE network-initiated trial.<sup>121</sup> This trial studied 278 children between the ages of 12 and 53 months who all had positive modified asthma predictive indices, recurrent wheezing episodes with a low grade of interval impairment, and at least one exacerbation in the previous year. Children were randomly assigned to receive nebulized budesonide suspensions for 1 year as either an intermittent high-dose regimen (1.0 mg twice daily for 7 days starting at the onset of predefined respiratory tract illness symptoms) or a daily low-dose regimen (0.5 mg nightly) with corresponding placebos in both treatment arms. The two regimens were similar with respect to exacerbation frequency (primary outcome) and other measures of asthma severity including the time to first exacerbation. The mean exposure to budesonide was 104 mg less with the intermittent regimen.

Although the results of this trial indicate that, in preschool children with this type of pre-asthma phenotype, intermittent therapy versus continuous therapy would be a therapeutic consideration, the lack of a placebo group in this study does not permit more exact interpretations of these findings. Inclusion of a placebo group was not permitted by the various human subjects committees of the clinical centers participating in this

trial. This was due to the intensity of the symptom severity pattern present in the children prior to enrollment in the trial.

### ROLE OF LEUKOTRIENES MODIFIERS IN VIRAL-INDUCED WHEEZING

The cysteinyl leukotrienes have been identified as important mediators in the complex pathophysiology of asthma.<sup>128</sup> Leukotrienes are detectable in the blood, urine, nasal secretions, sputum and bronchoalveolar lavage fluid of patients with chronic asthma. In addition, leukotrienes are released during acute asthma episodes. As a result of the potential for these mediators to influence airway tone, inflammatory cascades and mucus secretion, antagonists for their receptors have been developed and extensively studied. The cysteinyl leukotriene receptor antagonist, montelukast, has been the most frequently studied in both preschool and school-aged children.<sup>120,129–136</sup>

In one of the initial clinical trials designed to primarily evaluate safety, patients aged 2 to 5 years were treated for over 12 weeks with montelukast administered as a 4-mg chewable tablet.<sup>129</sup> Efficacy outcomes were also evaluated secondarily. Compared with placebo, montelukast produced significant improvements in multiple parameters of asthma control including: daytime asthma symptoms (cough, wheeze, trouble breathing and activity limitation); overnight asthma symptoms (cough); the percentage of days with asthma symptoms; the percentage of days without asthma; the need for beta-agonist or oral corticosteroids; physician global evaluations; and peripheral blood eosinophils. The clinical benefit of montelukast was evident within 1 day of starting therapy. Improvements in asthma control were consistent across age, sex, race and study center, and whether or not patients had a positive *in vitro* allergen-specific IgE test.

Robertson et al evaluated the intermittent use of montelukast in 2- to 14-year-old children with histories of intermittent asthma.<sup>136</sup> The family was instructed to begin a 7-day treatment with montelukast (age-appropriate dose) at the onset of asthma symptoms or the first sign of an upper respiratory tract illness that had previously been associated with the subsequent development of lower airway asthma symptoms. Compared to placebo, montelukast treatment resulted in a modest reduction in acute healthcare resource utilization, symptoms, time off from school and parental time off work in children with intermittent asthma.

Bisgaard et al evaluated the efficacy of 1-year daily treatment with montelukast in children with intermittent asthma in reducing exacerbations.<sup>134</sup> The primary efficacy endpoint was the number of asthma exacerbation episodes defined as any three consecutive days with daytime symptoms (average score of four daily daytime symptom questions of at least 1.0 on each day) and at least two treatments of beta-agonist per day, or rescue use of oral/inhaled corticosteroids during 1 or more days, or a hospitalization because of asthma. Over 12 months of therapy, montelukast significantly reduced the rate of asthma exacerbations by 31.9% compared with placebo. The average rate of exacerbation episodes per patient was 1.60 episodes per year on montelukast compared with 2.34 episodes on placebo. Montelukast also delayed the median time to first exacerbation by approximately 2 months and the rate of inhaled corticosteroid courses compared with placebo. Unfortunately, treatment did not reduce the necessity for oral corticosteroid administration. One of the remarkable aspects of this trial was the marked

seasonal variation in exacerbation rates, with the summer months having less frequent exacerbations and no observed treatment effects. These data are an excellent documentation of the 'honeymoon' period from asthma symptoms that many clinicians observe in their patients during the summer months, most likely related to reduced numbers of respiratory tract illnesses.

Because infections with RSV in early life have been associated with an increased risk of developing recurrent wheezing and later asthma, two studies have evaluated the effects of montelukast treatment on the development of subsequent reactive airway disease symptoms. In the first 'pilot study',<sup>133</sup> children without a diagnosis of asthma (3–36 months old), hospitalized with acute RSV bronchiolitis, were randomized into a double-blind, parallel comparison of 5 mg montelukast or placebo given for 28 days starting within 7 days of the onset of symptoms. Infants on montelukast were free of any symptoms on 22% of the days and nights compared with 4% of the days and nights in infants on placebo. Daytime cough was significantly reduced, as were exacerbations in those children on active treatment. In contrast, in a follow-up study in children 3 to 24 months of age conducted over a period of 24 weeks, montelukast treatment did not alleviate post RSV-induced respiratory tract symptoms.<sup>135</sup>

In school-aged children, montelukast has been shown to be less effective compared to inhaled corticosteroid treatment in reducing the need for oral corticosteroid use and time to treatment failure over a 1-year time period.<sup>131</sup> Both of these outcomes could be considered surrogates for respiratory pathogen-induced asthma exacerbations or worsening of overall asthma control.

### ANTI-INFECTION THERAPY

Therapy for infection-induced asthma could potentially include one or more of the following approaches: avoidance, non-medicinal interventions, vaccination, antimicrobial drug therapy and/or immunotherapy (monoclonal antibodies directed against the relevant pathogens). The ubiquitous nature of respiratory pathogens in the environment and the social nature of interactions in childhood (daycare, school, older siblings, etc.) make avoidance strategies unfeasible. Indeed, on average, children experience 2 to 8 or more 'colds' per year during their preschool years.

The cure for the common cold remains elusive; as such, a number of non-medicinal interventions have been tried. Vitamin C has long been touted for common cold treatment; however, a meta-analysis of common cold treatment studies found no significant effects on either prevention or treatment.<sup>137</sup> A Cochrane review of clinical studies found evidence that zinc lozenges reduce common cold duration but have significant side-effects including bad taste and nausea.<sup>138</sup> Large-scale trials of Echinacea have provided no evidence of efficacy.<sup>139,140</sup> There is evidence that warm drinks, as recommended for generations, can provide symptomatic relief from malaise and nasal symptoms without troublesome side-effects.<sup>141</sup> These approaches obviously are aimed at symptom reduction of the common cold but their effects on asthma control or exacerbations have not been directly evaluated.

Given the close relationship between viral infections and wheezing illnesses in children, it would be attractive to apply antiviral strategies to the prevention and treatment of asthma,

and both RV and RSV are obvious targets. Attempts at developing an RSV vaccine have so far been unsuccessful; however, recent data have provided renewed encouragement.<sup>142,143</sup> Unfortunately, vaccination to prevent RV infection is even more challenging due to the large number of serotypes. As an alternative, several types of antiviral agents are in development, and several compounds with activity against RV have been tested in clinical trials.

Improved knowledge of RV molecular virology has led to several attempts to develop antiviral agents. Interferon- $\alpha$  has antiviral effects in vitro and shortens the duration and severity of colds, but topical application led to nasal irritation and bleeding.<sup>144–146</sup> Anti-ICAM-1 and soluble ICAM-1 were developed to prevent binding of major group viruses to their receptor.<sup>147–149</sup> Capsid binding agents that bind to the VP1 pocket and inhibit viral binding and/or uncoating<sup>150–152</sup> have shown modest antiviral effects and efficacy in clinical trials.<sup>153,154</sup> An inhibitor to the 3C protease (rupintrivir) also showed broad anti-HRV activity in vitro and efficacy in clinical trials.<sup>155</sup> Unfortunately, these antiviral approaches have not so far led to development of a clinically useful medication. The molecules tested to date have been limited by combinations of modest efficacy, side-effects and/or drug interactions.<sup>156</sup>

Another new approach has been to boost antiviral defenses in the lung with inhaled IFN- $\beta$ . In a randomized study, subjects with persistent asthma and a history of exacerbations with colds were treated with either nebulized IFN- $\beta$  or placebo within 24 hours of the onset of cold symptoms.<sup>157</sup> In the intent-to-treat population, there were no significant effects on the asthma symptoms scores (which was the primary outcome) but IFN- $\beta$  treatment improved recovery of peak expiratory flow. Notably, IFN- $\beta$  was well tolerated and also induced expression of innate antiviral effectors in the blood and sputum. In a subgroup analysis of study subjects with more severe asthma (British Thoracic Society Step 4 and 5), colds were associated with increased symptoms in the placebo group but not in IFN- $\beta$ -treated subjects. These exciting new findings, if confirmed, suggest that inhaled IFN- $\beta$  used at the first sign of a cold could be a useful adjunct to standard therapy in patients with more severe asthma.

Two recent trials evaluating the efficacy of monoclonal antibody therapy directed specifically against RSV and the allergic antibody, IgE, have yielded interesting results. The first trial studied the anti-RSV monoclonal antibody, palivizumab, in a double-blind, placebo-controlled trial: 429 otherwise healthy preterm (33–35 weeks' gestational age) infants were randomly assigned to receive either monthly palivizumab injections or placebo during the RSV season. The prespecified primary outcome was the total number of parent-reported wheezing days in the first year of life. Nasopharyngeal swabs were taken during respiratory episodes for viral analysis. Palivizumab treatment resulted in a relative reduction of 61% in the total number of wheezing days during the first year of life (1.8% vs 4.5% in the placebo group). During this time, the proportion of infants with recurrent wheeze was 10 percentage points lower in patients treated with palivizumab (11% vs 21%). As discussed above, the data generated thus far cannot ascertain what effect such treatment may have on the subsequent development of asthma in later childhood.

The second trial evaluated the anti-IgE monoclonal antibody, omalizumab, which specifically targets the Fc portion of IgE to prevent binding to the surface of cells and is therefore a

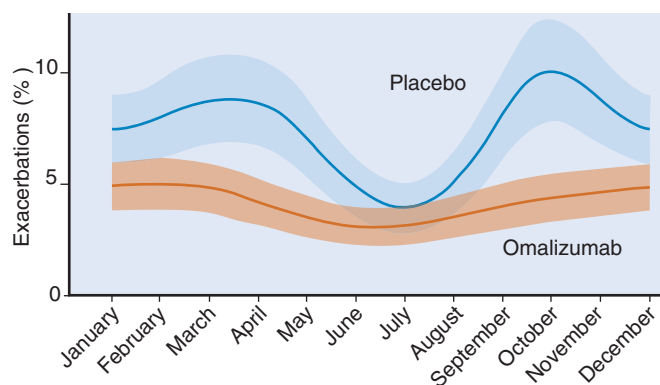

**Figure 31-1** The figure shows the seasonality of asthma exacerbations in children and demonstrates that blocking IgE responses with omalizumab blunts the seasonal rise in virus-induced exacerbations. (With permission from Busse WW, Morgan WJ, Gergen PJ, Mitchell HE, Gern JE, Liu AH, et al. Randomized trial of omalizumab (anti-IgE) for asthma in inner-city children. *N Engl J Med* 2011;364(11):1005–15.)

narrowly focussed intervention for type I hypersensitivity. In a placebo-controlled trial of guidelines-based asthma treatment compared to omalizumab added to standard therapy, omalizumab prevented the seasonal increases in exacerbations during the fall and spring, which are peak times for viral exacerbations (Figure 31-1).<sup>158</sup> Analysis of viruses in nasal secretions during a subset of exacerbations confirmed that the treatment group had fewer viral and nonviral exacerbations. This study provides direct evidence that IgE-mediated inflammation contributes to the risk of virus-induced exacerbations of asthma. These observations indicate that interactions between allergic sensitization (antigen-specific IgE antibody formation) and viral respiratory illnesses play an important role in asthma control. Finally, it will be of interest to determine whether other drugs targeting specific type-2 cytokines (e.g. mepolizumab and IL-5)<sup>159</sup> can also reduce the risk of virus-induced exacerbations.

## Use of Antibiotics in Asthma

Asthma guidelines both in the USA (<http://www.nhlbi.nih.gov/health-pro/guidelines/current/asthma-guidelines/full-report.htm>) and internationally (<http://www.ginasthma.org>) have not recommended the use of antibiotics to treat asthma exacerbations because the majority of the exacerbations have been considered to be triggered by viral respiratory tract infections. Nonetheless, oral antibiotics are frequently prescribed for wheezing illnesses in preschool children (650 antibiotic prescriptions/1,000 wheezing children).<sup>160</sup> Furthermore, recent data indicate that 28% of preschool children who make a physician visit for wheezing receive a prescription for an antibiotic within 2 days of the visit, and 77% receive a prescription for an antibiotic within 7 days. These prescriptions are dominated by azithromycin, the use of which increased 15-fold between 1995 and 2001.<sup>160</sup>

As noted previously, bacteria (either alone or in combination with viral pathogens) have now been demonstrated to potentially play a role in acute wheezing episodes and increases in asthma symptoms in children.<sup>27,84</sup> These observations might be an explanation as to why antibiotic administration has been observed to provide some clinical benefit by practitioners. Recent findings indicate that certain antimicrobials may have



not only antibacterial properties but antiviral and/or anti-inflammatory properties as well.

As a class, macrolides have been demonstrated to provide clinical benefit in airway diseases such as cystic fibrosis<sup>161</sup> and diffuse panbronchiolitis,<sup>162</sup> possibly through mechanisms unrelated to antimicrobial activity. Viral infections, particularly those caused by RV, are associated with neutrophilic inflammation and increased IL-8 expression.<sup>163</sup> Neutrophils are the predominant inflammatory cell at the onset of most infections,<sup>164</sup> including those with RV,<sup>163,165</sup> and although many chemottractants participate in summoning neutrophils to the site of infection, IL-8 seems to play a central role.<sup>166</sup> Neutrophils are relatively insensitive to the therapeutic effects of corticosteroids<sup>167</sup> but, interestingly, azithromycin has been demonstrated to attenuate immunoinflammatory responses and may reduce the ensuing destructive neutrophilic inflammation. In addition, recent data demonstrated that azithromycin reduces RV replication and increases interferon gene expression in human bronchial epithelial cells.<sup>168</sup> These effects may have substantial clinical relevance, as recent studies have demonstrated that primary bronchial epithelial cells from asthmatics have deficient *ex vivo* induction of IFN- $\beta$  and IFN- $\lambda$  after infection with RV,<sup>81</sup> and the levels of IFN- $\lambda$  were inversely related to severity of RV-induced asthma exacerbations in terms of decline in FEV<sub>1</sub> and viral load. These findings are especially important because, in children, viral infections have been shown by many investigators to be a major etiologic agent in episodes of clinically significant lower respiratory tract symptoms.<sup>3,92,169</sup>

In contrast to *in vitro* observations indicating a potential useful role of these agents in treating infection-induced loss of asthma control or exacerbations, their efficacy in humans has not been consistently shown. Black et al were one of the first groups to demonstrate a potential beneficial effect. They studied the effect of roxithromycin in subjects with asthma and immunoglobulin G (IgG) or IgA antibodies to *Chlamydomphila pneumoniae*. Subjects were randomized to 6 weeks of treatment with roxithromycin or placebo. This intervention led to improvements in asthma control but the benefit was not sustained.<sup>170</sup> Kraft and colleagues performed an additional study using a different antimicrobial. They found that treatment with

clarithromycin for 8 weeks was beneficial in improving lung function, but only in those patients with positive PCR findings for *Mycoplasma pneumoniae* or *C. pneumoniae*.<sup>171</sup> These initial intriguing results were later expanded upon by the Asthma Clinical Research Network who treated asthma patients that were not adequately controlled on inhaled corticosteroid monotherapy with clarithromycin or placebo for 16 weeks. They found that this treatment intervention did not further improve asthma control. Although there was an improvement in airway hyperresponsiveness with clarithromycin, this benefit was not accompanied by improvements in other secondary outcomes.<sup>172</sup> One additional study suggested that some benefit might be possible following intervention with this antimicrobial class. Johnston et al administered the ketolide telithromycin (a semi-synthetic derivative of erythromycin) for 10 days to adults with asthma seen within the first 24 hours of acute asthma episodes. This intervention resulted in significant improvements in symptom scores and lung function over the next 7 days relative to placebo.<sup>173</sup> However, there was no relationship between bacteriologic status and the response to telithromycin treatment, suggesting a mechanism of action unrelated to the antimicrobial properties of telithromycin.

## Conclusions

Infections play a critical role in the inception and exacerbation of asthma. Viral infections are the most common cause of wheezing in infants and children. Interactions between underlying allergy and virus infections lead to the greatest risk of asthma inception and exacerbation. New data indicate that the airway microbiome may play a critical role in modulating the response to respiratory viral infections, and virus-induced alterations in airway microbial populations likely also contribute to illness severity. Treatment of virus-induced wheezing and asthma exacerbations remains challenging and novel therapies and approaches to the prevention of asthma and asthma exacerbations are needed.

The complete reference list can be found on the companion Expert Consult website at <http://www.expertconsult.inkling.com>.

## KEY REFERENCES

- Jackson DJ, Gangnon RE, Evans MD, Roberg KA, Anderson EL, Pappas TE, et al. Wheezing rhinovirus illnesses in early life predict asthma development in high-risk children. *Am J Respir Crit Care Med* 2008;178:667–72.
- Cox DW, Bizzintino J, Ferrari G, Khoo SK, Zhang G, Whelan S, et al. Human rhinovirus species C infection in young children with acute wheeze is associated with increased acute respiratory hospital admissions. *Am J Respir Crit Care Med* 2013;188:1358–64.
- Wu P, Dupont WD, Griffin MR, Carroll KN, Mitchel EF, Gebretsadik T, et al. Evidence of a causal role of winter virus infection during infancy in early childhood asthma. *Am J Respir Crit Care Med* 2008;178:1123–9.
- Bisgaard H, Hermansen MN, Buchvald F, Loland L, Halkjaer LB, Bonnelykke K, et al. Childhood asthma after bacterial colonization of the airway in neonates. *N Engl J Med* 2007;357:1487–95.
- Bisgaard H, Hermansen MN, Bonnelykke K, Stokholm J, Batty F, Skyyt NL, et al. Association of bacteria and viruses with wheezy episodes in young children: prospective birth cohort study. *BMJ* 2010;341:c4978.
- Wark PA, Johnston SL, Bucchieri F, Powell R, Puddicombe S, Laza-Stanca V, et al. Asthmatic bronchial epithelial cells have a deficient innate immune response to infection with rhinovirus. *J Exp Med* 2005;201:937–47.
- Heymann PW, Carper HT, Murphy DD, Platts-Mills TA, Patrie J, McLaughlin AP, et al. Viral infections in relation to age, atopy, and season of admission among children hospitalized for wheezing. *J Allergy Clin Immunol* 2004;114:239–47.
- Beigelman A, King TS, Mauger D, Zeiger RS, Strunk RC, Kelly HW, et al. Do oral corticosteroids reduce the severity of acute lower respiratory tract illnesses in preschool children with recurrent wheezing? *J Allergy Clin Immunol* 2013;131:1518–25 e14.
- Guilbert TW, Morgan WJ, Zeiger RS, Mauger DT, Boehmer SJ, Szefer SJ, et al. Long-term inhaled corticosteroids in preschool children at high risk for asthma. *N Engl J Med* 2006;354:1985–97.
- Busse WW, Morgan WJ, Gergen PJ, Mitchell HE, Gern JE, Liu AH, et al. Randomized trial of omalizumab (anti-IgE) for asthma in inner-city children. *N Engl J Med* 2011;364:1005–15.

## REFERENCES

- Jartti T, Lehtinen P, Vuorinen T, Osterback R, van den Hoogen HB, Osterhaus AD, et al. Respiratory picornaviruses and respiratory syncytial virus as causative agents of acute expiratory wheezing in children. *Emerg Infect Dis* 2004;10:1095–101.
- Jackson DJ, Gangnon RE, Evans MD, Roberg KA, Anderson EL, Pappas TE, et al. Wheezing rhinovirus illnesses in early life predict asthma development in high-risk children. *Am J Respir Crit Care Med* 2008;178:667–72.
- Gern JE, Pappas T, Visness CM, Jaffee KF, Lemanske RF, Togias A, et al. Comparison of the etiology of viral respiratory illnesses in inner-city and suburban infants. *J Infect Dis* 2012;206:1342–9.
- Stein RT, Sherrill D, Morgan WJ, Holberg CJ, Halonen M, Taussig LM, et al. Respiratory syncytial virus in early life and risk of wheeze and allergy by age 13 years. *Lancet* 1999;354:541–5.
- Sigurs N, Gustafsson PM, Bjarnason R, Lundberg F, Schmidt S, Sigurbergsson F, et al. Severe respiratory syncytial virus bronchiolitis in infancy and asthma and allergy at age 13. *Am J Respir Crit Care Med* 2005;171:137–41.
- Blanken MO, Rovers MM, Molenaar JM, Winkler-Seinstra PL, Meijer A, Kimpen JL, et al. Respiratory syncytial virus and recurrent wheeze in healthy preterm infants. *N Engl J Med* 2013;368:1791–9.
- Mejias A, Dimo B, Suarez NM, Garcia C, Suarez-Arrabal MC, Jartti T, et al. Whole blood gene expression profiles to assess pathogenesis and disease severity in infants with respiratory syncytial virus infection. *PLoS Med* 2013;10:e1001549.
- Kotaniemi-Syrjanen A, Vainionpää R, Reijonen TM, Waris M, Korhonen K, Korppi M. Rhinovirus-induced wheezing in infancy – the first sign of childhood asthma? *J Allergy Clin Immunol* 2003;111:66–71.
- Jackson DJ. Early-life viral infections and the development of asthma: a target for asthma prevention? *Curr Opin Allergy Clin Immunol* 2014;14:131–6.
- Lee WM, Kiesner C, Pappas T, Lee I, Grindle K, Jartti T, et al. A diverse group of previously unrecognized human rhinoviruses are common causes of respiratory illnesses in infants. *PLoS ONE* 2007;2:e966.
- Lau SK, Yip CC, Tsoi HW, Lee RA, So LY, Lau YL, et al. Clinical features and complete genome characterization of a distinct human rhinovirus (HRV) genetic cluster, probably representing a previously undetected HRV species, HRV-C, associated with acute respiratory illness in children. *J Clin Microbiol* 2007;45:3655–64.
- Miller EK, Edwards KM, Weinberg GA, Iwane MK, Griffin MR, Hall CB, et al. A novel group of rhinoviruses is associated with asthma hospitalizations. *J Allergy Clin Immunol* 2009;123:98–104.
- Miller EK, Williams JV, Gebretsadik T, Carroll KN, Dupont WD, Mohamed YA, et al. Host and viral factors associated with severity of human rhinovirus-associated infant respiratory tract illness. *J Allergy Clin Immunol* 2011;127:883–91.
- Cox DW, Bizzintino J, Ferrari G, Khoo SK, Zhang G, Whelan S, et al. Human rhinovirus species C infection in young children with acute wheeze is associated with increased acute respiratory hospital admissions. *Am J Respir Crit Care Med* 2013;188:1358–64.
- Lee WM, Lemanske RF Jr, Evans MD, Vang F, Pappas T, Gangnon R, et al. Human rhinovirus species and season of infection determine illness severity. *Am J Respir Crit Care Med* 2012;186:886–91.
- Carroll KN, Wu P, Gebretsadik T, Griffin MR, Dupont WD, Mitchel EF, et al. Season of infant bronchiolitis and estimates of subsequent risk and burden of early childhood asthma. *J Allergy Clin Immunol* 2009;123:964–6.
- Wu P, Dupont WD, Griffin MR, Carroll KN, Mitchel EF, Gebretsadik T, et al. Evidence of a causal role of winter virus infection during infancy in early childhood asthma. *Am J Respir Crit Care Med* 2008;178:1123–9.
- Openshaw PJ, Dean GS, Culley FJ. Links between respiratory syncytial virus bronchiolitis and childhood asthma: clinical and research approaches. *Pediatr Infect Dis J* 2003;22(Suppl. 2):S58–64.
- Martin RJ, Kraft M, Chu HW, Berns EA, Cassell GH. A link between chronic asthma and chronic infection. *J Allergy Clin Immunol* 2001;107:595–601.
- Bisgaard H, Hermansen MN, Buchvald F, Loland L, Halkjaer LB, Bonnelykke K, et al. Childhood asthma after bacterial colonization of the airway in neonates. *N Engl J Med* 2007;357:1487–95.
- Webley WC, Tilahun Y, Lay K, Patel K, Stuart ES, Andrzejewski C, et al. Occurrence of Chlamydia trachomatis and Chlamydia pneumoniae in paediatric respiratory infections. *Eur Respir J* 2009;33:360–7.
- Sutherland ER, Brandorff JM, Martin RJ. Atypical bacterial pneumonia and asthma risk. *J Asthma* 2004;41:863–8.
- Hahn DL, Dodge RW, Golubjatnikov R. Association of Chlamydia pneumoniae (strain TWAR) infection with wheezing, asthmatic bronchitis, and adult-onset asthma. *JAMA* 1991;266:225–30.
- Kraft M, Cassell GH, Henson JE, Watson H, Williamson J, Marmion BP, et al. Detection of Mycoplasma pneumoniae in the airways of adults with chronic asthma. *Am J Respir Crit Care Med* 1998;158:998–1001.
- Biscardi S, Lorrot M, Marc E, Moulin F, Boutonnat-Faucher B, Heilbronner C, et al. Mycoplasma pneumoniae and asthma in children. *Clin Infect Dis* 2004;38:1341–6.
- von Linstow ML, Schonning K, Hoegh AM, Sevelsted A, Vissing NH, Bisgaard H. Neonatal airway colonization is associated with troublesome lung symptoms in infants. *Am J Respir Crit Care Med* 2013;188:1041–2.
- Bisgaard H, Hermansen MN, Bonnelykke K, Stokholm J, Baty F, Skytt NL, et al. Association of bacteria and viruses with wheezy episodes in young children: prospective birth cohort study. *BMJ* 2010;341:c4978.
- Hilty M, Burke C, Pedro H, Cardenas P, Bush A, Bossley C, et al. Disordered microbial communities in asthmatic airways. *PLoS ONE* 2010;5:e8578.
- Marri PR, Stern DA, Wright AL, Billheimer D, Martinez FD. Asthma-associated differences in microbial composition of induced sputum. *J Allergy Clin Immunol* 2013;131:346–52 e1-3.
- Fujimura KE, Johnson CC, Ownby DR, Cox MJ, Brodie EL, Havstad SL, et al. Man's best friend? The effect of pet ownership on house dust microbial communities. *J Allergy Clin Immunol* 2010;126:410–12, 2.
- Lynch SV, Wood RA, Boushey H, Bacharier LB, Bloomberg GR, Kattan M, et al. Effects of early-life exposure to allergens and bacteria on recurrent wheeze and atopy in urban children. *J Allergy Clin Immunol* 2014;134:593–601 e12.
- Fujimura KE, Demoor T, Rauch M, Faruqi AA, Jang S, Johnson CC, et al. House dust exposure mediates gut microbiome Lactobacillus enrichment and airway immune defense against allergens and virus infection. *Proc Natl Acad Sci U S A* 2014;111:805–10.
- Ege MJ, Mayer M, Normand AC, Genuneit J, Cookson WO, Braun-Fahrlander C, et al. Exposure to environmental microorganisms and childhood asthma. *N Engl J Med* 2011;364:701–9.
- Johnston SL, Pattemore PK, Sanderson G, Smith S, Lampe F, Josephs L, et al. Community study of role of viral infections in exacerbations of asthma in 9–11 year old children. *BMJ* 1995;310:1225–9.
- Johnston NW, Johnston SL, Norman GR, Dai J, Sears MR. The September epidemic of asthma hospitalization: school children as disease vectors. *J Allergy Clin Immunol* 2006;117:557–62.
- Bizzintino J, Lee WM, Laing IA, Vang F, Pappas T, Zhang G, et al. Association between human rhinovirus C and severity of acute asthma in children. *Eur Respir J* 2011;37:1037–42.
- Allander T, Jartti T, Gupta S, Niesters HG, Lehtinen P, Osterback R, et al. Human bocavirus and acute wheezing in children. *Clin Infect Dis* 2007;44:904–10.
- Edwards KM, Zhu Y, Griffin MR, Weinberg GA, Hall CB, Szilagyi PG, et al. Burden of human metapneumovirus infection in young children. *N Engl J Med* 2013;368:633–43.
- Papadopoulos NG, Christodoulou I, Rohde G, Agache I, Almqvist C, Bruno A, et al. Viruses and bacteria in acute asthma exacerbations – a GA(2) LEN-DARE systematic review. *Allergy* 2011;66:458–68.
- Corne JM, Marshall C, Smith S, Schreiber J, Sanderson G, Holgate ST, et al. Frequency, severity, and duration of rhinovirus infections in asthmatic and non-asthmatic individuals: a longitudinal cohort study. *Lancet* 2002;359:831–4.
- Molyneux PL, Mallia P, Cox MJ, Footitt J, Willis-Owen SA, Homola D, et al. Outgrowth of the bacterial airway microbiome after rhinovirus exacerbation of chronic obstructive pulmonary disease. *Am J Respir Crit Care Med* 2013;188:1224–31.
- Kieninger E, Singer F, Tapparel C, Alves MP, Latzin P, Tan HL, et al. High rhinovirus burden in lower airways of children with cystic fibrosis. *Chest* 2013;143:782–90.
- O'Brian AL, Lemanske RF Jr, Evans MD, Gangnon RE, Gern JE, Jackson DJ. Recurrent severe exacerbations in early life and reduced lung function at school age. *J Allergy Clin Immunol* 2012;129:1162–4.
- O'Byrne PM, Pedersen S, Lamm CJ, Tan WC, Busse WW. Severe exacerbations and decline in

- lung function in asthma. *Am J Respir Crit Care Med* 2009;179:19–24.
45. McFadden ER Jr, Pichurko BM, Bowman HF, Ingenito E, Burns S, Dowling N, et al. Thermal mapping of the airways in humans. *J Appl Physiol* 1985;58:564–70.
  46. Ashraf S, Brockman-Schneider R, Bochkov YA, Pasic TR, Gern JE. Biological characteristics and propagation of human rhinovirus-C in differentiated sinus epithelial cells. *Virology* 2013;436:143–9.
  47. Papadopoulos NG, Sanderson G, Hunter J, Johnston SL. Rhinoviruses replicate effectively at lower airway temperatures. *J Med Virol* 1999;58:100–4.
  48. Mosser AG, Brockman-Schneider RA, Amineva SP, Burchell L, Sedgwick JB, Busse WW, et al. Similar frequency of rhinovirus-infectable cells in upper and lower airway epithelium. *J Infect Dis* 2002;185:734–43.
  49. Papadopoulos NG, Bates PJ, Bardin PG, Papi A, Leir SH, Fraenkel DJ, et al. Rhinoviruses infect the lower airways. *J Infect Dis* 2000;181:1875–84.
  50. Mosser AG, Vrtis R, Burchell L, Lee WM, Dick CR, Weisshaar E, et al. Quantitative and qualitative analysis of rhinovirus infection in bronchial tissues. *Am J Respir Crit Care Med* 2005;171:645–51.
  51. Gern JE, Galagan DM, Jarjour NN, Dick EC, Busse WW. Detection of rhinovirus RNA in lower airway cells during experimentally-induced infection. *Am J Respir Crit Care Med* 1997;155:1159–61.
  52. Iwane MK, Prill MM, Lu X, Miller EK, Edwards KM, Hall CB, et al. Human rhinovirus species associated with hospitalizations for acute respiratory illness in young US children. *J Infect Dis* 2011;204:1702–10.
  53. Miller EK, Lu X, Erdman DD, Poehling KA, Zhu Y, Griffin MR, et al. Rhinovirus-associated hospitalizations in young children. *J Infect Dis* 2007;195:773–81.
  54. Sajjan U, Wang Q, Zhao Y, Gruenert DC, Hershenson MB. Rhinovirus disrupts the barrier function of polarized airway epithelial cells. *Am J Respir Crit Care Med* 2008;178:1271–81.
  55. Nakagome K, Bochkov YA, Ashraf S, Brockman-Schneider RA, Evans MD, Pasic TR, et al. Effects of rhinovirus species on viral replication and cytokine production. *J Allergy Clin Immunol* 2014;134:332–41.
  56. Hendley JO. The host response, not the virus, causes the symptoms of the common cold. *Clin Infect Dis* 1998;26:847–8.
  57. Leigh R, Oyelusi W, Wiehler S, Koetzler R, Zaheer RS, Newton R, et al. Human rhinovirus infection enhances airway epithelial cell production of growth factors involved in airway remodeling. *J Allergy Clin Immunol* 2008;121:1238–45.
  58. Tacon CE, Wiehler S, Holden NS, Newton R, Proud D, Leigh R. Human rhinovirus infection up-regulates MMP-9 production in airway epithelial cells via NF- $\kappa$ B. *Am J Respir Cell Mol Biol* 2010;43:201–9.
  59. Lee CG, Yoon HJ, Zhu Z, Link H, Wang Z, Gwaltney JM, et al. Respiratory syncytial virus stimulation of vascular endothelial cell growth factor/vascular permeability factor. *Am J Respir Cell Mol Biol* 2000;23:662–9.
  60. Dosanjh A, Rednam S, Martin M. Respiratory syncytial virus augments production of fibroblast growth factor basic in vitro: implications for a possible mechanism of prolonged wheezing after infection. *Pediatr Allergy Immunol* 2003;14:437–40.
  61. Kurt-Jones EA, Popova L, Kwinn L, Haynes LM, Jones LP, Tripp RA, et al. Pattern recognition receptors TLR4 and CD14 mediate response to respiratory syncytial virus. *Nat Immunol* 2000;1:398–401.
  62. Vareille M, Kieninger E, Edwards MR, Regamey N. The airway epithelium: soldier in the fight against respiratory viruses. *Clin Microbiol Rev* 2011;24:210–29.
  63. Holt PG. Pulmonary dendritic cells in local immunity to inert and pathogenic antigens in the respiratory tract. *Proc Am Thorac Soc* 2005;2:116–20.
  64. Marr N, Wang TI, Kam SH, Hu YS, Sharma AA, Lam A, et al. Attenuation of respiratory syncytial virus-induced and RIG-I-dependent type I IFN responses in human neonates and very young children. *J Immunol* 2014;192:948–57.
  65. Cardell LO, Agusti C, Takeyama K, Stjarne P, Nadel JA. LTB(4)-induced nasal gland serous cell secretion mediated by neutrophil elastase. *Am J Respir Crit Care Med* 1999;160:411–14.
  66. Denlinger LC, Shi L, Guadarrama A, Schell K, Green D, Morrill A, et al. Attenuated P2X7 pore function as a risk factor for virus-induced loss of asthma control. *Am J Respir Crit Care Med* 2009;179:265–70.
  67. Garbino J, Soccac PM, Aubert JD, Rochat T, Meylan P, Thomas Y, et al. Respiratory viruses in bronchoalveolar lavage: a hospital-based cohort study in adults. *Thorax* 2009;64:399–404.
  68. Kainulainen L, Vuorinen T, Rantakokko-Jalava K, Osterback R, Ruuskanen O. Recurrent and persistent respiratory tract viral infections in patients with primary hypogammaglobulinemia. *J Allergy Clin Immunol* 2010;126:120–6.
  69. Hu C, Wedde-Beer K, Auais A, Rodriguez MM, Piedimonte G. Nerve growth factor and nerve growth factor receptors in respiratory syncytial virus-infected lungs. *Am J Physiol Lung Cell Mol Physiol* 2002;283:L494–502.
  70. Tortorolo L, Langer A, Polidori G, Vento G, Stampaciachere B, Aloe L, et al. Neurotrophin overexpression in lower airways of infants with respiratory syncytial virus infection. *Am J Respir Crit Care Med* 2005;172:233–7.
  71. Rynko AE, Fryer AD, Jacoby DB. Interleukin-1 $\beta$  mediates virus-induced M2 muscarinic receptor dysfunction and airway hyperreactivity. *Am J Respir Cell Mol Biol* 2014;51:494–501.
  72. Naclerio RM, Proud D, Lichtenstein LM, Kagey-Sobotka A, Hendley JO, Sorrentino J, et al. Kinins are generated during experimental rhinovirus colds. *J Infect Dis* 1988;157:133–42.
  73. Seymour ML, Gilby N, Bardin PG, Fraenkel DJ, Sanderson G, Penrose JE, et al. Rhinovirus infection increases 5-lipoxygenase and cyclooxygenase-2 in bronchial biopsy specimens from nonatopic subjects. *J Infect Dis* 2002;185:540–4.
  74. Sanders SP, Proud D, Permutt S, Siekierski ES, Yachechko R, Liu MC. Role of nasal nitric oxide in the resolution of experimental rhinovirus infection. *J Allergy Clin Immunol* 2004;113:697–702.
  75. Sperber SJ, Hendley JO, Hayden FG, Riker DK, Sorrentino JV, Gwaltney JM. Effects of naproxen on experimental rhinovirus colds – a randomized, double-blind, controlled trial. *Ann Intern Med* 1992;117:37–41.
  76. Eggleston PA, Hendley JO, Gwaltney JM Jr. Mediators of immediate hypersensitivity in nasal secretions during natural colds and rhinovirus infection. *Acta Otolaryngol Suppl* 1984;413:25–35.
  77. Copenhaver CC, Gern JE, Li Z, Shult PA, Rosenthal LA, Mikus LD, et al. Cytokine response patterns, exposure to viruses, and respiratory infections in the first year of life. *Am J Respir Crit Care Med* 2004;170:175–80.
  78. Renzi PM, Turgeon JP, Marcotte JE, Drblik SP, Berube D, Gagnon MF, et al. Reduced interferon-gamma production in infants with bronchiolitis and asthma. *Am J Respir Crit Care Med* 1999;159(5 Pt 1):1417–22.
  79. Stern DA, Guerra S, Halonen M, Wright AL, Martinez FD. Low IFN-gamma production in the first year of life as a predictor of wheeze during childhood. *J Allergy Clin Immunol* 2007;120:835–41.
  80. Papadopoulos NG, Stanciu LA, Papi A, Holgate ST, Johnston SL. A defective type I response to rhinovirus in atopic asthma. *Thorax* 2002;57:328–32.
  81. Contoli M, Message SD, Laza-Stanca V, Edwards MR, Wark PA, Bartlett NW, et al. Role of deficient type III interferon-lambda production in asthma exacerbations. *Nat Med* 2006;12:1023–6.
  82. Wark PA, Johnston SL, Bucchieri F, Powell R, Puddicombe S, Laza-Stanca V, et al. Asthmatic bronchial epithelial cells have a deficient innate immune response to infection with rhinovirus. *J Exp Med* 2005;201:937–47.
  83. Message SD, Laza-Stanca V, Mallia P, Parker HL, Zhu J, Kebabdzic T, et al. Rhinovirus-induced lower respiratory illness is increased in asthma and related to virus load and Th1/2 cytokine and IL-10 production. *Proc Natl Acad Sci U S A* 2008;105:13562–7.
  84. Kloepfer KM, Lee WM, Pappas TE, Kang TJ, Vrtis RF, Evans MD, et al. Detection of pathogenic bacteria during rhinovirus infection is associated with increased respiratory symptoms and asthma exacerbations. *J Allergy Clin Immunol* 2014;133:1301–7 e3.
  85. Green RM, Custovic A, Sanderson G, Hunter J, Johnston SL, Woodcock A. Synergism between allergens and viruses and risk of hospital admission with asthma: case-control study. *BMJ* 2002;324:763.
  86. Chauhan AJ, Inskip HM, Linaker CH, Smith S, Schreiber J, Johnston SL, et al. Personal exposure to nitrogen dioxide (NO<sub>2</sub>) and the severity of virus-induced asthma in children. *Lancet* 2003;361:1939–44.
  87. Tarlo SM, Broder I, Corey P, Chan-Yeung M, Ferguson A, Becker A, et al. The role of symptomatic colds in asthma exacerbations: Influence of outdoor allergens and air pollutants. *J Allergy Clin Immunol* 2001;108:52–8.
  88. Sly PD, Boner AL, Bjorksten B, Bush A, Custovic A, Eigenmann PA, et al. Early identification of atopy in the prediction of persistent asthma in children. *Lancet* 2008;372:1100–6.
  89. Simpson A, Tan VY, Winn J, Svensen M, Bishop CM, Heckerman DE, et al. Beyond atopy: multiple patterns of sensitization in relation to



- asthma in a birth cohort study. *Am J Respir Crit Care Med* 2010;181:1200–6.
90. Jackson DJ, Evans MD, Gangnon RE, Tisler CJ, Pappas TE, Lee WM, et al. Evidence for a causal relationship between allergic sensitization and rhinovirus wheezing in early life. *Am J Respir Crit Care Med* 2012;185:281–5.
  91. Kusel MM, de Klerk NH, Kebabdzic T, Vohma V, Holt PG, Johnston SL, et al. Early-life respiratory viral infections, atopic sensitization, and risk of subsequent development of persistent asthma. *J Allergy Clin Immunol* 2007;119:1105–10.
  92. Heymann PW, Carper HT, Murphy DD, Platts-Mills TA, Patrie J, McLaughlin AP, et al. Viral infections in relation to age, atopy, and season of admission among children hospitalized for wheezing. *J Allergy Clin Immunol* 2004;114:239–47.
  93. Soto-Quiros M, Avila L, Platts-Mills TA, Hunt JF, Erdman DD, Carper H, et al. High titers of IgE antibody to dust mite allergen and risk for wheezing among asthmatic children infected with rhinovirus. *J Allergy Clin Immunol* 2012;129:1499–505 e5.
  94. Kloepfer KM, Gern JE. Virus/allergen interactions and exacerbations of asthma. *Immunol Allergy Clin North Am* 2010;30:553–63, vii.
  95. Jakiela B, Brockman-Schneider R, Amineva S, Lee WM, Gern JE. Basal cells of differentiated bronchial epithelium are more susceptible to rhinovirus infection. *Am J Respir Cell Mol Biol* 2008;38:517–23.
  96. Lachowicz-Scroggins ME, Boushey HA, Finkbeiner WE, Widdicombe JH. Interleukin-13-induced mucous metaplasia increases susceptibility of human airway epithelium to rhinovirus infection. *Am J Respir Cell Mol Biol* 2010;43:652–61.
  97. Gern JE, Calhoun W, Swenson C, Shen G, Busse WW. Rhinovirus infection preferentially increases lower airway responsiveness in allergic subjects. *Am J Respir Crit Care Med* 1997;155:1872–6.
  98. Durrani SR, Montville DJ, Pratt AS, Sahu S, Devries MK, Rajamanickam V, et al. Innate immune responses to rhinovirus are reduced by the high-affinity IgE receptor in allergic asthmatic children. *J Allergy Clin Immunol* 2012;130:489–95.
  99. Gill MA, Bajwa G, George TA, Dong CC, Dougherty II, Jiang N, et al. Counterregulation between the FcεRI pathway and antiviral responses in human plasmacytoid dendritic cells. *J Immunol* 2010;184:5999–6006.
  100. Pritchard AL, Carroll ML, Burel JG, White OJ, Phipps S, Upham JW. Innate IFNs and plasmacytoid dendritic cells constrain Th2 cytokine responses to rhinovirus: a regulatory mechanism with relevance to asthma. *J Immunol* 2012;188:5898–905.
  101. Lynch JB, Mazzone SB, Rogers MJ, Arikatt JJ, Loh Z, Pritchard AL, et al. The plasmacytoid dendritic cell: at the cross-roads in asthma. *Eur Respir J* 2014;43:264–75.
  102. Hall CB. Therapy for bronchiolitis: when some become none. *N Engl J Med* 2007;357:402–4.
  103. Gadomski AM, Brower M. Bronchodilators for bronchiolitis. *Cochrane Database Syst Rev* 2010;12:CD001266.
  104. Zhang L, Mendoza-Sassi RA, Wainwright C, Klassen TP. Nebulized hypertonic saline solution for acute bronchiolitis in infants. *Cochrane Database Syst Rev* 2008;4:CD006458.
  105. Umoren R, Odey F, Meremikwu MM. Steam inhalation or humidified oxygen for acute bronchiolitis in children up to three years of age. *Cochrane Database Syst Rev* 2011;1:CD006435.
  106. Everard ML, Bara A, Kurian M, Elliott TM, Ducharme F, Mayowe V. Anticholinergic drugs for wheeze in children under the age of two years. *Cochrane Database Syst Rev* 2005;3:CD001279.
  107. Fernandes RM, Bialy LM, Vandermeer B, Tjosvold L, Plint AC, Patel H, et al. Glucocorticoids for acute viral bronchiolitis in infants and young children. *Cochrane Database Syst Rev* 2010;10:CD004878.
  108. Skjerven HO, Hunderi JO, Bruggmann-Pieper SK, Brun AC, Engen H, Eskedal L, et al. Racemic adrenaline and inhalation strategies in acute bronchiolitis. *N Engl J Med* 2013;368:2286–93.
  109. Alansari K, Sakran M, Davidson BL, Ibrahim K, Alrefai M, Zakaria I. Oral dexamethasone for bronchiolitis: a randomized trial. *Pediatrics* 2013;132:e810–16.
  110. Rachelefsky G. Treating exacerbations of asthma in children: the role of systemic corticosteroids. *Pediatrics* 2003;112:382–97.
  111. Rowe BH, Spooner CH, Ducharme FM, Bretzlaff JA, Bota GW. Corticosteroids for preventing relapse following acute exacerbations of asthma. *Cochrane Database Syst Rev* 2007;3:CD000195.
  112. Rowe BH, Spooner C, Ducharme FM, Bretzlaff JA, Bota GW. Early emergency department treatment of acute asthma with systemic corticosteroids. *Cochrane Database Syst Rev* 2001;1:CD002178.
  113. Busse WW, Lemanske RF Jr. Expert Panel Report 3: moving forward to improve asthma care. *J Allergy Clin Immunol* 2007;120:1012–14.
  114. Tal A, Levy N, Bearman JE. Methylprednisolone therapy for acute asthma in infants and toddlers: a controlled clinical trial. *Pediatrics* 1990;86:350–6.
  115. Oommen A, Lambert PC, Grigg J. Efficacy of a short course of parent-initiated oral prednisolone for viral wheeze in children aged 1–5 years: randomised controlled trial. *Lancet* 2003;362:1433–8.
  116. Panickar J, Lakhnypaul M, Lambert PC, Kenia P, Stephenson T, Smyth A, et al. Oral prednisolone for preschool children with acute virus-induced wheezing. *N Engl J Med* 2009;360:329–38.
  117. Csonka P, Kaila M, Laippala P, Iso-Mustajarvi M, Vesikari T, Ashorn P. Oral prednisolone in the acute management of children age 6 to 35 months with viral respiratory infection-induced lower airway disease: a randomized, placebo-controlled trial. *J Pediatr* 2003;143:725–30.
  118. Grant CC, Duggan AK, Deangelis C. Independent parental administration of prednisone in acute asthma: A double-blind, placebo-controlled, crossover study. *Pediatrics* 1995;96(2 Pt 1):224–9.
  119. Bush A. Practice imperfect – treatment for wheezing in preschoolers. *N Engl J Med* 2009;360:409–10.
  120. Bacharier LB, Phillips BR, Zeiger RS, Szeffler SJ, Martinez FD, Lemanske RF Jr, et al. Episodic use of an inhaled corticosteroid or leukotriene receptor antagonist in preschool children with moderate-to-severe intermittent wheezing. *J Allergy Clin Immunol* 2008;122:1127–35.
  121. Zeiger RS, Mauger D, Bacharier LB, Guilbert TW, Martinez FD, Lemanske RF Jr, et al. Daily or intermittent budesonide in preschool children with recurrent wheezing. *N Engl J Med* 2011;365:1990–2001.
  122. Beigelman A, King TS, Mauger D, Zeiger RS, Strunk RC, Kelly HW, et al. Do oral corticosteroids reduce the severity of acute lower respiratory tract illnesses in preschool children with recurrent wheezing? *J Allergy Clin Immunol* 2013;131:1518–25 e14.
  123. Chang TS, Lemanske RF Jr, Guilbert TW, Gern JE, Coen MH, Evans MD, et al. Evaluation of the modified asthma predictive index in high risk preschool children. *J Allergy Clin Immunol Pract* 2013;1:152–6.
  124. Beigelman A, Zeiger RS, Kelly HW, Bacharier LB, Childhood Asthma Research and Education Network of National Heart, Lung, and Blood Institute. The challenge of treating preschool wheezing episodes: the need for evidence-based approaches. *J Allergy Clin Immunol* 2014;133:1016–17.
  125. Guilbert TW, Morgan WJ, Krawiec M, Lemanske RF Jr, Sorkness C, Szeffler SJ, et al. The Prevention of Early Asthma in Kids study: design, rationale and methods for the Childhood Asthma Research and Education network. *Control Clin Trials* 2004;25:286–310.
  126. Grad R, Morgan WJ. Long-term outcomes of early-onset wheeze and asthma. *J Allergy Clin Immunol* 2012;130:299–307.
  127. Guilbert TW, Morgan WJ, Zeiger RS, Mauger DT, Boehmer SJ, Szeffler SJ, et al. Long-term inhaled corticosteroids in preschool children at high risk for asthma. *N Engl J Med* 2006;354:1985–97.
  128. Drazen JM, Israel E, O'Byrne PM. Treatment of asthma with drugs modifying the leukotriene pathway. *N Engl J Med* 1999;340:197–206.
  129. Knorr B, Franchi LM, Bisgaard H, Vermeulen JH, LeSouef P, Santanello N, et al. Montelukast, a leukotriene receptor antagonist, for the treatment of persistent asthma in children aged 2 to 5 years. *Pediatrics* 2001;108:E48.
  130. Knorr B, Matz J, Bernstein JA, Nguyen H, Seidenberg BC, Reiss TF, et al. Montelukast for chronic asthma in 6- to 14-year old children: a randomized double-blind trial. *Pediatric Montelukast Study Group. JAMA* 1998;279:1181–6.
  131. Sorkness CA, Lemanske RF Jr, Mauger DT, Boehmer SJ, Chinchilli VM, Martinez FD, et al. Long-term comparison of 3 controller regimens for mild-moderate persistent childhood asthma: The Pediatric Asthma Controller Trial. *J Allergy Clin Immunol* 2007;119:64–72.
  132. Szeffler SJ, Phillips BR, Martinez FD, Chinchilli VM, Lemanske RF Jr, Strunk RC, et al. Characterization of within-subject responses to fluticasone and montelukast in childhood asthma. *J Allergy Clin Immunol* 2005;115:233–42.
  133. Bisgaard H. A randomized trial of montelukast in respiratory syncytial virus postbronchiolitis. *Am J Respir Crit Care Med* 2003;167:379–83.
  134. Bisgaard H, Zielen S, Garcia-Garcia ML, Johnston SL, Gilles L, Menten J, et al. Montelukast reduces asthma exacerbations in 2- to 5-year-old children with intermittent asthma. *Am J Respir Crit Care Med* 2005;171:315–22.



135. Bisgaard H, Flores-Nunez A, Goh A, Azimi P, Halkas A, Malice MP, et al. Study of montelukast for the treatment of respiratory symptoms of post-respiratory syncytial virus bronchiolitis in children. *Am J Respir Crit Care Med* 2008;178:854–60.
136. Robertson CF, Price D, Henry R, Mellis C, Glasgow N, Fitzgerald D, et al. Short-course montelukast for intermittent asthma in children: a randomized controlled trial. *Am J Respir Crit Care Med* 2007;175:323–9.
137. Douglas RM, Hemila H, Chalker E, Treacy B, Vitamin C for preventing and treating the common cold. *Cochrane Database Syst Rev* 2007;3:CD000980.
138. Singh M, Das RR. Zinc for the common cold. *Cochrane Database Syst Rev* 2013;6:CD001364.
139. Turner RB, Bauer R, Woelkart K, Hulsey TC, Gangemi JD. An evaluation of *Echinacea angustifolia* in experimental rhinovirus infections. *N Engl J Med* 2005;353:341–8.
140. Barrett B, Brown R, Rakel D, Mundt M, Bone K, Barlow S, et al. *Echinacea* for treating the common cold: a randomized trial. *Ann Intern Med* 2010;153:769–77.
141. Sanu A, Eccles R. The effects of a hot drink on nasal airflow and symptoms of common cold and flu. *Rhinology* 2008;46:271–5.
142. Murray J, Saxena S, Sharland M. Preventing severe respiratory syncytial virus disease: passive, active immunisation and new antivirals. *Arch Dis Child* 2014;99:469–73.
143. Yang K, Varga SM. Mucosal vaccines against respiratory syncytial virus. *Current Opin Virol* 2014;6C:78–84.
144. Hayden FG, Gwaltney JM Jr. Intranasal interferon-alpha 2 treatment of experimental rhinoviral colds. *J Infect Dis* 1984;150:174–80.
145. Hayden FG, Albrecht JK, Kaiser DL, Gwaltney JM Jr. Prevention of natural colds by contact prophylaxis with intranasal alpha 2-interferon. *N Engl J Med* 1986;314:71–5.
146. Farr BM, Gwaltney JM Jr, Adams KF, Hayden FG. Intranasal interferon-alpha 2 for prevention of natural rhinovirus colds. *Antimicrob Agents Chemother* 1984;26:31–4.
147. Ohlin A, Hoover-Litty H, Sanderson G, Paessens A, Johnston SL, Holgate ST, et al. Spectrum of activity of soluble intercellular adhesion molecule-1 against rhinovirus reference strains and field isolates. *Antimicrob Agents Chemother* 1994;38:1413–15.
148. Marlin SD, Staunton DE, Springer TA, Stratowa C, Sommergruber W, Merluzzi VJ. A soluble form of intercellular adhesion molecule-1 inhibits rhinovirus infection. *Nature* 1990;344:70–2.
149. Casasnovas JM, Springer TA. Pathway of rhinovirus disruption by soluble intercellular adhesion molecule 1 (ICAM-1): an intermediate in which ICAM-1 is bound and RNA is released. *J Virol* 1994;68:5882–9.
150. Turner RB, Dutko FJ, Goldstein NH, Lockwood G, Hayden FG. Efficacy of oral WIN 54954 for prophylaxis of experimental rhinovirus infection. *Antimicrob Agents Chemother* 1993;37:297–300.
151. Shepard DA, Heinz BA, Rueckert RR. WIN 52035-2 inhibits both attachment and eclipse of human rhinovirus 14. *J Virol* 1993;67:2245–54.
152. Andries K, Dewindt B, Snoeks J, Wouters L, Moereels H, Lewi PJ, et al. Two groups of rhinoviruses revealed by a panel of antiviral compounds present sequence divergence and differential pathogenicity. *J Virol* 1990;64:1117–23.
153. Hayden FG, Herrington DT, Coats TL, Kim K, Cooper EC, Villano SA, et al. Efficacy and safety of oral pleconaril for treatment of colds due to picornaviruses in adults: results of 2 double-blind, randomized, placebo-controlled trials. *Clin Infect Dis* 2003;36:1523–32.
154. Hayden FG, Coats T, Kim K, Hassman HA, Blatter MM, Zhang B, et al. Oral pleconaril treatment of picornavirus-associated viral respiratory illness in adults: efficacy and tolerability in phase II clinical trials. *Antivir Ther* 2002;7:53–65.
155. Hayden FG, Turner RB, Gwaltney JM, Chiburris K, Gersten M, Hsyu P, et al. Phase II, randomized, double-blind, placebo-controlled studies of rupintrivir nasal spray 2-percent suspension for prevention and treatment of experimentally induced rhinovirus colds in healthy volunteers. *Antimicrob Agents Chemother* 2003;47:3907–16.
156. Turner RB. New considerations in the treatment and prevention of rhinovirus infections. *Pediatr Ann* 2005;34:53–7.
157. Djukanovic R, Harrison T, Johnston SL, Gabbay F, Wark P, Thomson NC, et al. The effect of inhaled IFN-beta on worsening of asthma symptoms caused by viral infections. A randomized trial. *Am J Respir Crit Care Med* 2014;190:145–54.
158. Busse WW, Morgan WJ, Gergen PJ, Mitchell HE, Gern JE, Liu AH, et al. Randomized trial of omalizumab (anti-IgE) for asthma in inner-city children. *N Engl J Med* 2011;364:1005–15.
159. Haldar P, Brightling CE, Hargadon B, Gupta S, Monteiro W, Sousa A, et al. Mepolizumab and exacerbations of refractory eosinophilic asthma. *N Engl J Med* 2009;360:973–84.
160. Kozyrskyj AL, Dahl ME, Ungar WJ, Becker AB, Law BJ. Antibiotic treatment of wheezing in children with asthma: what is the practice? *Pediatrics* 2006;117:e1104–10.
161. Saiman L, Marshall BC, Mayer-Hamblett N, Burns JL, Quittner AL, Cibene DA, et al. Azithromycin in patients with cystic fibrosis chronically infected with *Pseudomonas aeruginosa*: a randomized controlled trial. *JAMA* 2003;290:1749–56.
162. Koyama H, Geddes DM. Erythromycin and diffuse panbronchiolitis. *Thorax* 1997;52:915–18.
163. Gern JE, Martin MS, Anklam KA, Shen K, Roberg KA, Carlson-Dakes KT, et al. Relationships among specific viral pathogens, virus-induced interleukin-8, and respiratory symptoms in infancy. *Pediatr Allergy Immunol* 2002;13:386–93.
164. Lacy P, Eitzen G. Control of granule exocytosis in neutrophils. *Front Biosci* 2008;13:5559–70.
165. Bentley JK, Newcomb DC, Goldsmith AM, Jia Y, Sajjan US, Hershenson MB. Rhinovirus activates interleukin-8 expression via a Src/p110beta phosphatidylinositol 3-kinase/Akt pathway in human airway epithelial cells. *J Virol* 2007;81:1186–94.
166. Kobayashi Y. The role of chemokines in neutrophil biology. *Front Biosci* 2008;13:2400–7.
167. Norzila MZ, Fakes K, Henry RL, Simpson J, Gibson PG. Interleukin-8 secretion and neutrophil recruitment accompanies induced sputum eosinophil activation in children with acute asthma. *Am J Respir Crit Care Med* 2000;161(3 Pt 1):769–74.
168. Gielen V, Johnston SL, Edwards MR. Azithromycin induces anti-viral responses in bronchial epithelial cells. *Eur Respir J* 2010;36:646–54.
169. Busse WW, Lemanske RF Jr, Gern JE. Role of viral respiratory infections in asthma and asthma exacerbations. *Lancet* 2010;376:826–34.
170. Black PN, Blasi F, Jenkins CR, Scicchitano R, Mills GD, Rubinfeld AR, et al. Trial of roxithromycin in subjects with asthma and serological evidence of infection with *Chlamydia pneumoniae*. *Am J Respir Crit Care Med* 2001;164:536–41.
171. Kraft M, Cassell GH, Pak J, Martin RJ. *Mycoplasma pneumoniae* and *Chlamydia pneumoniae* in asthma: effect of clarithromycin. *Chest J* 2002;121:1782–8.
172. Sutherland ER, King TS, Icitovic N, Ameredes BT, Bleeker E, Boushey HA, et al. A trial of clarithromycin for the treatment of suboptimally controlled asthma. *J Allergy Clin Immunol* 2010;126:747–53.
173. Johnston SL, Blasi F, Black PN, Martin RJ, Farrell DJ, Nieman RB. The effect of telithromycin in acute exacerbations of asthma. *N Engl J Med* 2006;354:1589–600.

# Special Considerations for Infants and Young Children

RONINA A. COVAR | JOSEPH D. SPAHN

## KEY POINTS

- The care of infants and small children with suspected asthma deserves special consideration because of the potential to modulate the disease process early on and alleviate the increased morbidity associated with uncontrolled asthma in this age group.
- After confounders and masqueraders of asthma have been excluded in the evaluation of children with suspected asthma, recurrent wheezing in infants and young children still comprises a heterogeneous group of conditions with different risk factors and prognoses.
- The diagnosis of asthma in infants and small children is often based on clinical grounds and complicated by the lack of clinically available tools that meet the criteria for the definition of asthma used in older children and adults such as airway inflammation, bronchial hyperresponsiveness and airflow limitation.
- Difficulties in the management of asthma include limited effective and convenient delivery devices, complete dependence on the caregivers to carry out the treatment regimen, and an inadequate selection of medications completely devoid of adverse effects.
- A partnership approach with emphasis on education, monitoring and training is key in the effective management of chronic cough or recurrent wheezing illnesses in very young children.
- Clinical trials using as needed treatment interventions have shown favorable efficacy outcomes, aimed at preventing severe exacerbations in young children with recurrent wheezing; however, trials aimed at primary prevention are still lacking.

The prevalence of asthma has increased even in the last decade but a better understanding of the mechanisms of asthma and the availability of more effective treatment may be responsible for the stabilization of the steady increase in asthma morbidity and mortality noted since the 1980s.<sup>1</sup> From data in the recent National Surveillance of Asthma,<sup>2</sup> current asthma was reported in 6% of children between 0 and 4 years old, with at least two thirds having at least one asthma attack in the previous year. The most important reason why asthma in infants and younger children deserves special consideration is the fact that healthcare utilization (ambulatory, emergency department visits and inpatient hospital admissions) for children under the

age of 4 years is greater than those of other age groups.<sup>2</sup> In addition, younger children with asthma are also more likely to be readmitted to the hospital for acute exacerbations.<sup>3</sup> In a retrospective analysis of 49 asthmatic children whose mean age was 5.2 years (range 2 months to 16 years) admitted to a community-based pediatric intensive care unit over a 10-year period, as many as 75% were 6 years or younger.<sup>4</sup> The public health consequences of dealing with asthma in children include the number of missed work days parents/guardians incur in order to care for an acutely ill child. Some studies have hinted that pulmonary development in infancy can be adversely affected by asthma, resulting in a decrease in lung function of approximately 20% by adulthood.<sup>5</sup>

Relevant clinical practice guidelines developed in recent years have addressed special challenges in the management of asthma in this age group.<sup>6,7</sup> Many issues are unique to this age group: identifying very young children with recurrent episodes of cough and wheeze associated with viral illnesses who will develop persistent asthma later in life, presence of confounding factors or disease masqueraders, who needs controller therapy and when to start treatment, what medications to use, how best to deliver the medications and how to monitor the response to treatment.

## Predicting Who is Likely to Develop Persistent Asthma

Recurrent wheezing in infants and young children comprises a heterogeneous group of conditions with different risk factors and prognoses. Viral infections (respiratory syncytial virus, rhinovirus, coronavirus, human metapneumovirus, adenovirus, parainfluenza and adenovirus) are common triggers of wheezing in preschool age children, even in those who will not develop persistent asthma later on. Factors or exposures early in life such as prematurity, fetal nutrition, duration of pregnancy, viral lower respiratory tract infections in the first years of life, cigarette smoke exposure, air pollution, postnatal nutrition, breastfeeding, family size, maternal age, socioeconomic status and allergen exposure have been implicated to varying degrees. Observational studies have also demonstrated an increased risk of asthma attributed to acetaminophen exposure during prenatal periods, infancy, childhood and even adulthood.<sup>8-11</sup> Genetics, atopy and prematurity appear to be the most important host risk factors in the development of asthma.

Several types of 'wheezers' in the young age group based on time of onset and outcome (transient or intermittent vs persistent) have been identified from longitudinal studies.<sup>12,13</sup> The investigators from the Tucson Children's Respiratory Group

enrolled over 1,000 newborns served by a large health maintenance organization to evaluate factors involved in early-onset wheezing in relationship to persistent wheezing at 6 years of life.<sup>13</sup> About half of the children had at least one episode of wheezing by 6 years of age. Nearly one third of the cohort had at least one episode of wheezing by 3 years of age. Only 40% of children who wheezed early had persistent wheezing at age 6 years. Of the total group, 20% had at least one episode of wheezing associated with a respiratory tract infection during the first 3 years of life but had no wheezing at 6 years ('transient wheezers'), 14% did not wheeze during the first 3 years of life but had wheezing at 6 years ('late-onset wheezers'), and 15% had wheezing at age 3 and 6 years ('persistent wheezers'). The 'transient wheezers' were more likely to have diminished airway function and a history of maternal smoking and were less likely to be atopic. The 'late-onset wheezers' had a similar percentage of atopic children to 'persistent wheezers' and were likely to have mothers with asthma. Hence, there seems to be a similar genetic predisposition for the asthma phenotype characterizing both 'persistent' and 'late-onset wheezers'. Essentially all of the current natural history studies have found that allergic disease and evidence of pro-allergic immune development are significant risk factors for persistent asthma.

An asthma predictive index (API) using a combination of clinical and easily obtainable laboratory data to help identify children age  $\leq 3$  years with a history of wheezing at risk of developing persistent asthma was developed from the Tucson cohort.<sup>14</sup> Information on parental asthma diagnosis and prenatal maternal smoking status was obtained at enrollment, while the child's history of asthma and wheezing and physician-diagnosed allergic rhinitis or eczema, along with measurements of blood eosinophil count, were obtained at the follow-up visits. Two indices were used to classify the children. The stringent index required recurrent wheezing in the first 3 years plus one major (parental history of asthma or physician-diagnosed eczema) or two of three minor (eosinophilia, wheezing without colds, allergic rhinitis) risk factors, whereas the loose index required any episode of wheezing in the first 3 years plus one major or two of three minor risk factors. Children with a positive loose index were 2.6 to 5.5 times more likely to have active asthma sometime during the school years. In contrast, risk of asthma increased to 4.3 to 9.8 times when the stringent criteria were used. In addition, at least 90% of young children with a negative 'loose' or 'stringent' index will not develop 'active asthma' in the school age years.

A modified version of the API (mAPI) incorporates inhalant allergen sensitization as an additional major risk factor and food allergen sensitization as an additional minor risk factor to take into account important findings from other longitudinal natural history asthma studies.<sup>15</sup> In the Berlin Multicentre Allergy Study, additional risk factors for asthma and bronchial hyperreactivity at age 7 years included persistent sensitization to foods (i.e. hen's egg, cow's milk, wheat and/or soy) and perennial inhalant allergens (i.e. dust mite, cat), especially in early life.<sup>16,17</sup> In a prospective, randomized, controlled study of food allergen avoidance in infancy evaluating the development of atopy at age 7 years in a high-risk cohort, egg, milk and peanut allergen sensitization were risk factors for asthma.<sup>18</sup> With these additional considerations, an mAPI has been used in an early intervention study for young children with recurrent wheezing.<sup>19</sup> Henceforth, it has been adapted by the NAEPP EPR3 asthma guidelines as a requirement along with a history of four

wheezing episodes per year lasting more than 24 hours upon which initiation of controller therapy should be considered.<sup>6</sup>

These wheezing phenotypes derived from epidemiologic and longitudinal data are more helpful for prognostication and usually have limited clinical utility when a medical provider is faced with a child with recurrent wheezing or chronic cough. Hence, other phenotypes may have greater relevance when management decisions have to be made or clinical trials are undertaken. For example, a symptom-based classification, i.e. episodic (wheeze only in discrete time periods, mostly associated with upper respiratory infection) vs multi-trigger (symptom also occurs with activity, laughing, crying or even at night outside of an acute illness), was proposed by the European Task Force in 2008.<sup>20</sup> However its clinical applicability is limited as children can switch between the two categories at different times, and this classification does not consider the frequency, seasonality and severity of the episodes.<sup>21</sup> A preschool child may have exercise-induced wheeze only when he/she is also having an acute episode or shortly after. During the late fall, winter and early spring in most areas in the northern hemisphere, preschool children who are in regular contact with other children can develop back to back viral respiratory illnesses that can each last up to 2 weeks or even longer. A child with a viral illness requiring a hospital admission is in the same classification as a child whose viral-induced wheezing illness is treated with a bronchodilator alone. Lastly, it is not known if there is a unique immunopathologic difference that can affect treatment between the two phenotypes. Therefore, clinical guidelines suggest starting treatment based on frequency of symptoms, severity of episodes and presence of risk factors.

## Confounding Factors

The first practical consideration in approaching the wheezing child is to ensure that an alternative diagnosis is not present. In addition, infants and small children have a greater degree of bronchial hyperresponsiveness (BHR), which may predispose them to wheeze.<sup>22</sup>

The differential diagnosis of wheezing in infants and young children includes conditions such as foreign body aspiration, structural airway anomalies, congenital lobar emphysema, abnormalities of the great vessels (e.g. vascular rings), congenital heart disease, cystic fibrosis, recurrent aspiration, immunodeficiency, infections, ciliary dyskinesia and mediastinal masses. Other clinical features, such as neonatal onset of symptoms, associated failure to thrive, diarrhea or vomiting, focal lung or cardiovascular findings, clubbing, constant wheezing, and hypoxemia outside of an acute illness, suggest an alternative diagnosis and require special investigations. Additional factors in addition to age at onset of symptoms that should be taken into consideration include triggers for the respiratory symptoms and aggravating conditions such as nighttime occurrences, environmental exposure, physical exertion, feeding, positioning and infections. Clearly, making the correct diagnosis is essential because the treatment for these conditions can vary substantially. For example, in children with significant gastroesophageal reflux, improvement in asthma symptoms with concomitant reduction in asthma medication use occurred after a prokinetic agent was instituted.<sup>23</sup> A practical approach that can be considered for a young child in whom asthma is strongly suspected is an empiric trial of asthma controller therapy while other evaluations are still being pursued (Figure 32-1).

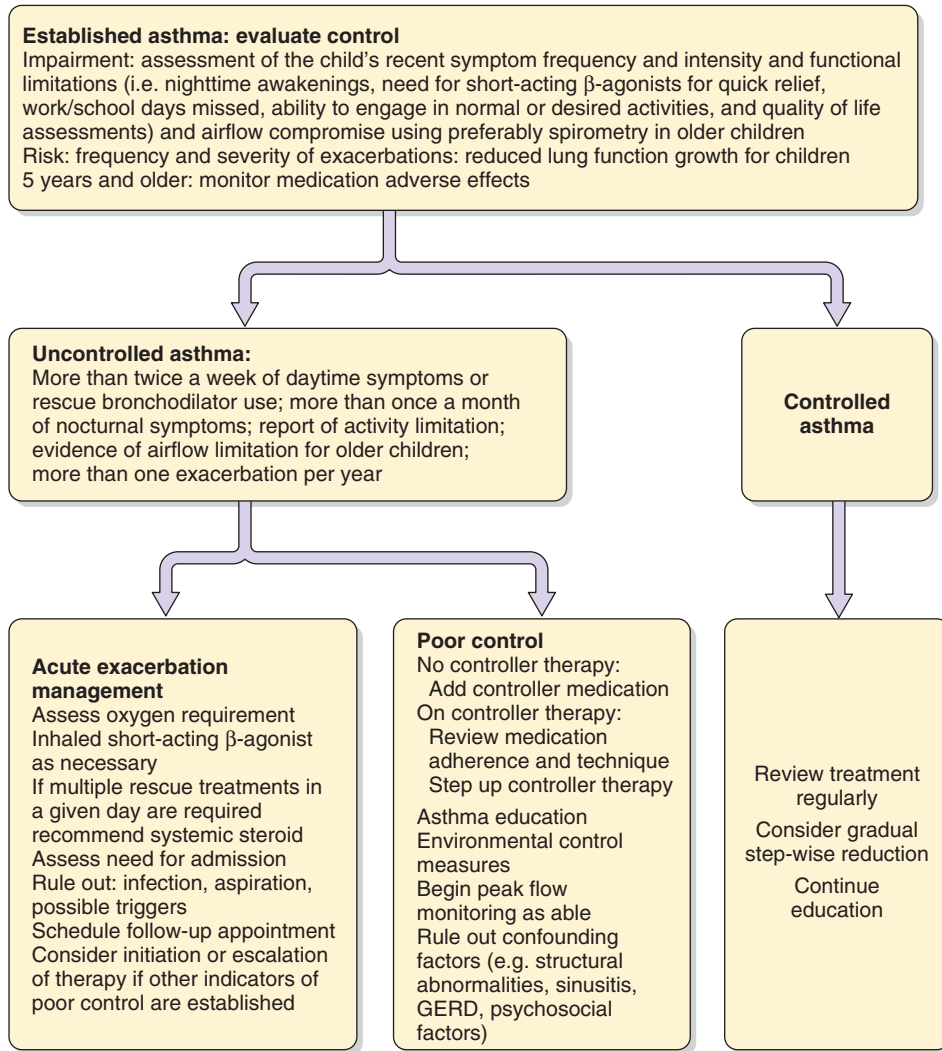
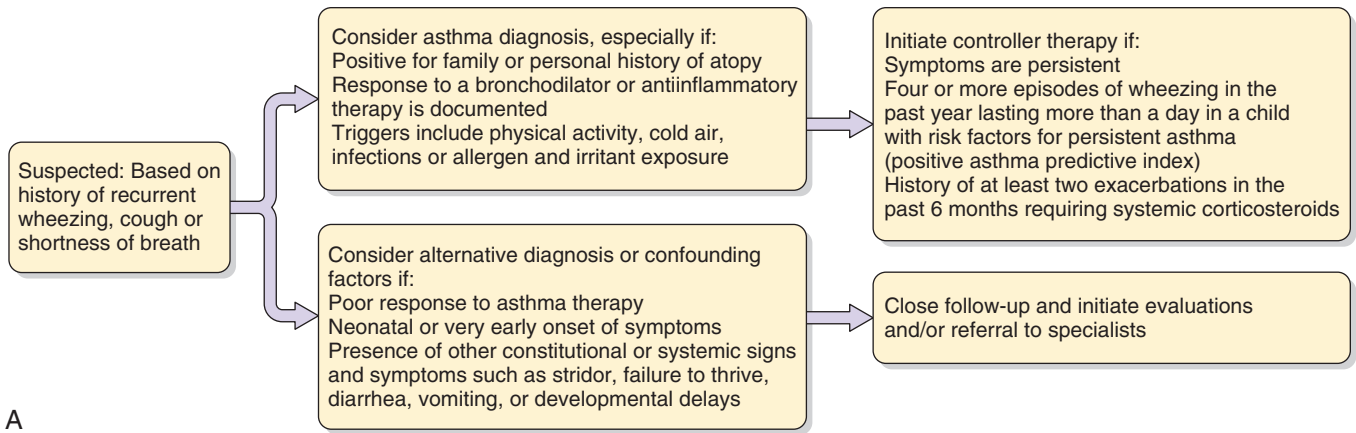

**Figure 32-1** Algorithm for suggested management of infants and young children with suspected or established asthma. GERD – gastroesophageal reflux disease.

## Diagnostic Tools to Evaluate Asthma in Young Children

Preschool children present some diagnostic challenges inherent to their young age such that a confirmation of a diagnosis can be difficult to make. Infants and young children are too young

to reliably perform objective measures of disease activity. Furthermore, they are unable to provide their own history so clinicians must depend on the parents'/caregivers' report. Werk et al sought to determine the factors primary care pediatricians believe are important in establishing an initial diagnosis of asthma.<sup>24</sup> Questionnaires on asthma diagnosis consisting of 20



factors obtained from the National Heart, Lung, and Blood Institute (NHLBI) National Asthma Education Prevention Program (NAEPP) Expert Panel Report 2 (EPR2) guidelines<sup>25</sup> and an expert local panel of subspecialists were sent to 862 active members of the Massachusetts American Academy of Pediatrics. Over 80% of the respondents rated five factors as necessary or important in establishing the diagnosis of asthma: recurrent wheezing, symptomatic improvement following bronchodilator use, presence of recurrent cough, exclusion of other diagnoses, and suggestive peak expiratory flow rate findings. Of note, 27% of the respondents indicated that a child had to be older than 2 years; 18% indicated that fever must be absent during an exacerbation.

The diagnosis of asthma in young children is based largely on clinical judgment and an assessment of symptoms and physical findings. The following characteristics are suggestive of asthma: wheezing or recurrent or persistent nonproductive cough or difficult breathing that may be worse at night or occurring with exercise, laughing, crying or exposure to tobacco smoke in the absence of a respiratory infection; reduced activity or interest in running or playing compared to other children with easy fatigability during walks; presence of other personal allergic diseases (atopic dermatitis or allergic rhinitis) or family history of asthma in first degree relatives; and response to either therapeutic trial of a corticosteroid or a short-acting bronchodilator as needed.<sup>7</sup> Because lung function measurements in infants and small children are difficult to obtain, a trial of treatment is often a practical way to make a diagnosis of asthma in young children.

At present, for adults and older children, easily performed lung function measures and noninvasive markers of airway inflammation can be used to make the diagnosis of asthma, monitor asthma control or guide therapeutic decisions. The following section will highlight available procedures and techniques with the potential to measure lung function and airway inflammation in the young child.

### FORCED OSCILLOMETRY

Forced oscillometry is a pulmonary function technique that measures respiratory system resistance (Rrs) and reactance (Xrs) at several frequencies. It involves the application of sine waves through a loudspeaker to the airway opening via a mouthpiece, through which the subject breathes normally for short periods of time. Measurements are carried out during tidal breathing over a 30-second interval with at least three efforts recorded. Given its relative ease of use, it is a reproducible and suitable measure of lung function in younger children.<sup>26</sup> Marotta et al performed pre- and post-bronchodilator spirometry and forced oscillometry in young children at risk for asthma and found no difference in baseline FEV<sub>1</sub> or resistance between children with asthma versus those without; the degree of bronchodilator response differentiated the two groups.<sup>27</sup> Some investigators believe that reactance at low frequencies is a reflection of peripheral airways function.<sup>28</sup>

Using three different lung function measures, Nielsen and Bisgaard evaluated the bronchodilator response of 92 children 2 to 5 years old, 55 of whom had asthma.<sup>29</sup> Children with asthma had diminished lung function compared to nonasthmatic children using any of the following measures: specific airway resistance (sRaw) utilizing whole body plethysmography, or respiratory resistance utilizing either an interrupter

technique (Rint) or impulse oscillation technique at 5 Hz (Rrs5). Both asthmatic and nonasthmatic children responded to terbutaline, although children with asthma reversed to a greater extent than the nonasthmatic children. The investigators found that sRaw utilizing body plethysmography best distinguished asthmatics from nonasthmatics based on bronchodilator response. They concluded that assessment of bronchodilator responsiveness using sRaw may help define asthma in young children.

### MEASUREMENT OF BRONCHIAL REACTIVITY

As with measurements of airflow limitation, procedures to assess BHR in infants and young children have distinctive challenges. Measurement of BHR using cold air (4 minutes of isocapnic hyperventilation) or dry air (6 minutes of eucapnic hyperventilation) challenge with sRaw as an outcome may be useful, practical alternatives to auscultatory pharmacologic or exercise bronchoprovocation challenges which are more difficult to standardize in young children.<sup>30</sup> Using a dry air challenge, magnitude of response was associated with a wheeze phenotype. Persistent wheezers had a larger increase in sRaw following eucapnic hyperventilation challenge compared with never wheezers, but no significant differences between never wheezers, late-onset or transient wheezers were seen.<sup>31</sup>

### MEASURES OF INFLAMMATION

Exhaled nitric oxide (eNO) levels are elevated in patients with asthma<sup>32</sup> and correlate positively with eosinophilic airway inflammation.<sup>33</sup> In addition, they rise during acute exacerbations<sup>34</sup> and fall following oral or inhaled corticosteroid (ICS) therapy.<sup>35,36</sup>

Online<sup>37</sup> and offline<sup>38</sup> eNO measurements can be reliably obtained in very young children. Reference values using an offline tidal breathing method in healthy preschool children have recently been published.<sup>39</sup> Higher mean ( $\pm$ SEM) eNO concentrations ( $14.1 \pm 1.8$  ppb) were found in infants and young children (age 7 to 33 months) presenting with an acute wheeze and a history of at least three prior wheezing episodes compared to first-time viral wheezers (age 9 to 14 months) ( $8.3 \pm 1.3$  ppb,  $P < .05$ ) and healthy matched controls ( $5.6 \pm 0.5$  ppb,  $P < .001$ ). No differences in eNO measurements were seen between the last two groups. In addition, eNO levels were reduced by 52% after steroid therapy to a level comparable to those of the healthy controls and first-time wheezers.<sup>38</sup>

Unlike sophisticated measures of lung function and BHR, eNO can be easily and quickly measured. An elevated eNO in preschool age children has been shown to predict asthma in school age.<sup>40</sup>

In one of the few studies designed specifically to address the role of eosinophil cationic protein (ECP) in young children with recurrent wheezing, Carlsen et al<sup>41</sup> found a strong correlation between serum ECP and response to albuterol/salbutamol using the tidal flow volume loop technique in children 0 to 2 years of age. These investigators suggested that ECP may be measuring airway inflammation and may have some prognostic value in diagnosing asthma in infants and toddlers with recurrent wheezing. The major drawback for ECP is its lack of sensitivity and blood sample collection.

Although direct investigation of the airway using bronchoscopy and biopsy is the gold standard for establishing airway

inflammation, it has limited clinical applicability, except when other pulmonary abnormalities are being considered. Understanding the underlying pathophysiology of the disease in children is critical in order to identify processes that can be impacted by interventions. Thickening of the bronchial epithelial reticular basement membrane (RBM) and eosinophilic airway inflammation are characteristic pathologic features of asthma found in children as young as 3 years old, but typically occurring between the ages of 6 to 16 years.<sup>42</sup> It is unclear when airway thickening begins since routine biopsy studies are not performed in infants.<sup>43</sup> Studies on bronchoalveolar lavages obtained from wheezing infants and preschool children revealed an overall increase in airway inflammation, though it is rarely eosinophilic. In one study in which bronchial biopsies were performed on symptomatic infants, there was no consistent relationship between RBM thickening and inflammation, clinical symptoms and variable airflow obstruction,<sup>44</sup> similar to findings from biopsy studies in older school aged children with asthma.<sup>45</sup> The use of sensitive, noninvasive physiologic and biologic markers is very limited in the clinical evaluation of young children with asthma and recurrent wheezing.

## Management

The goals of asthma management are not different between older children and preschool aged children – to attain good symptom control and allow normal activity levels, reduce exacerbations, optimize lung function and minimize medication side-effects. Available asthma guidelines such as the National Asthma Education Prevention Program Expert Panel Report 3 (NAEPP EPR3)<sup>6</sup> and the Global Initiative for Asthma (GINA) update 2014 report<sup>7</sup> acknowledge the special challenges unique to the management of asthma in preschool children; hence a specific approach and treatment recommendations for preschool children with asthma are presented. Both sets of guidelines emphasize maintenance of asthma control as the goal for asthma management and use of ICS as the preferred therapy for persistent asthma. A comprehensive management is outlined in several components and/or sections and generally includes: establishment of patient/doctor partnership and provision of education to enhance the patient's/family's knowledge and skills for self-management (appropriate use of devices and medications); identification and management of risk and precipitating factors and co-morbid conditions that may worsen asthma; adequate assessment and monitoring of disease activity (including symptom monitoring by parent/caregiver); appropriate selection of medications to address the patient's needs; and management of asthma exacerbations (with provision of a written asthma action plan). The details of each of these elements are discussed in Chapter 29.

Key differences between the two clinical guidelines are apparent. The approach implemented by the NAEPP EPR3 on starting controller therapy is based on the concept of asthma severity, which is the intrinsic intensity of disease and applicable for patients not receiving controller therapy. The guidelines have a separate set of criteria for various age groups and Table 32-1 summarizes the classification of asthma severity for children 0 to 4 years old. The classification of asthma severity is contingent upon the domains of impairment and risk and the level of severity is based on the most severe impairment or risk component. Impairment includes an assessment of the child's recent symptom frequency (daytime and nighttime), need for

short-acting  $\beta_2$ -agonists for quick relief, and ability to engage in normal or desired activities. Risk refers to an evaluation of the child's likelihood of developing asthma exacerbations. Of note, in the absence of frequent symptoms, 'persistent' asthma should be considered and therefore long-term controller therapy initiated for infants or children who have risk factors for asthma (i.e. using the mAPI: any of parental history of asthma, physician-diagnosed atopic dermatitis, or sensitization to aeroallergens OR two of the following: wheezing apart from colds, sensitization to foods, or peripheral eosinophilia) AND four or more episodes of wheezing over the past year that lasted longer than 1 day and affected sleep OR two or more exacerbations within 6 months requiring systemic corticosteroids.

In the most recent iteration of the GINA global strategy,<sup>7</sup> much emphasis is devoted to a 'shared-care approach' using an effective patient-healthcare provider partnership that has been shown to improve outcomes, and the process of 'assess, adjust treatment, and review response'. Eliciting specific goals of treatment from caregivers and providing education are key elements in this partnership. The process of assessing (diagnosis, symptom control, risk factors, inhaler technique, adherence and parent preference), adjusting treatment (medications, nonpharmacological strategies and treatment of modifiable risk factors), and reviewing response (medication effectiveness and side-effects) is recommended on an ongoing basis.

## CONTROLLER THERAPY FOR SMALL CHILDREN WITH PERSISTENT ASTHMA

Based on the NAEPP EPR3 guidelines,<sup>6</sup> upon establishing a diagnosis of asthma in young children, initiation of controller therapy is warranted for persistent asthma. The most important determinant of dosing is the clinician's judgment of the patient's presenting degree of severity. Initiation of long-term controller therapy should also be considered for infants and younger children who have risk factors for asthma (i.e. modified asthma predictive index: parental history of asthma, physician-diagnosed atopic dermatitis or sensitization to aeroallergens or two of the following: wheezing apart from colds, sensitization to foods or peripheral eosinophilia) and four or more episodes of wheezing over the past year that lasted longer than 1 day and affected sleep or two or more exacerbations in 6 months requiring systemic corticosteroids.

Medication dose adjustment is appropriate based on levels of asthma control, although dose-response relationships are not well studied. For preschool children already on a controller medication, management is tailored based on the child's level of control. As with the classification of asthma severity, assessment of asthma control is based on both impairment and risk (Table 32-2). The three levels of asthma control are 'well controlled', 'not well controlled' and 'very poorly controlled'. Children whose asthma is not well controlled have daytime symptoms or need for rescue albuterol >2 days/week, nighttime symptoms more than once a month but not more than once a week, 'some limitation' with normal activity, had two to three exacerbations in the past year, and an FEV<sub>1</sub> of 60–80% of predicted (or FEV<sub>1</sub>/FVC ratio 75–80%) for children 5 years of age or older. Children with very poorly controlled asthma have symptoms 'throughout the day', nocturnal symptoms more than once weekly, need for rescue albuterol several times per day, 'extreme limitations' with normal activity, had  $\geq 3$  exacerbations in the past year, and for children at least aged 5 years, an

TABLE  
32-1
**Classifying Asthma Severity and Initiating Treatment in Children Aged 0 to 4 Years: Assessing Severity and Initiating Treatment for Patients Who are not Currently Taking Long-term Control Medications**

Components of Severity		CLASSIFICATION OF ASTHMA SEVERITY (0–4 YR)			
		Intermittent	Mild	Moderate	Severe
Impairment	Daytime symptoms	≤2 d/wk	>2 d/wk but not daily	Daily	Throughout the day
	Nighttime awakenings	0	1–2×/mo	3–4×/mo	>1×/wk
	SABA use for symptoms (not EIB pretreatment)	≤2 d/wk	>2 d/wk but not daily and not more than once on any day	Daily	Several times per day
	Interference with normal activity	None	Minor limitation	Some limitation	Extremely limited
Risk	Exacerbations requiring systemic corticosteroids	0–1/yr	≥2 exacerbations in 6 months requiring systemic corticosteroids, or ≥4 wheezing episodes/1yr lasting >1 day and risk factors for persistent asthma		
		Consider severity and interval since last exacerbation Frequency and severity may fluctuate over time Exacerbations of any severity may occur in patients in any severity category			
Recommended step for initiating therapy		Step 1	Step 2	Step 3 and consider short course of oral systemic corticosteroids	
		In 2–6 weeks, depending on severity, evaluate level of asthma control that is achieved. If no clear benefit is observed within 4–6 weeks, consider adjusting therapy or alternative diagnoses			

National Asthma Education and Prevention Program: Expert Panel Report 3 (EPR 3): Guidelines for the Diagnosis and Management of Asthma – Summary Report 2007. *J Allergy Clin Immunol* 2007;120(Suppl):S94–138. Available at: <http://www.nhlbi.nih.gov/guidelines/asthma/asthgdln.htm>.

**Notes:**

- The stepwise approach is meant to assist, not replace, the clinical decision-making required to meet individual patient needs.
- Level of severity is determined by both impairment and risk. Assess impairment domain by patient's/caregiver's recall of previous 2–4 weeks. Symptom assessment for longer periods should reflect a global assessment such as inquiring whether a patient's asthma is better or worse since the last visit. Assign severity to the most severe category in which any feature occurs.
- At present, there are inadequate data to correspond frequencies of exacerbations with different levels of asthma severity. For treatment purposes, patients who had ≥2 exacerbations requiring oral systemic corticosteroids in the past 6 months, or ≥4 wheezing episodes in the past year, and who have risk factors for persistent asthma may be considered the same as patients who have persistent asthma, even in the absence of impairment levels consistent with persistent asthma.

EIB – Exercise-induced bronchospasm; SABA – short-acting  $\beta_2$ -agonist use.

FEV<sub>1</sub> of <60% of predicted or FEV<sub>1</sub>/FVC ratio <75%. Using a validated questionnaire to monitor quality of life for older children is recommended and perhaps the TRACK questionnaire<sup>42</sup> discussed in a subsequent section may now be applied in younger children.

The NAEPP EPR3 provides an expanded stepwise treatment approach (Figure 32-2) even for young children. The choice of initial therapy is based on assessment of asthma severity. For patients who are already on controller therapy, modification of treatment is based on assessment of asthma control and responsiveness to therapy. A major objective of this approach is to identify and treat all 'persistent' and uncontrolled asthma with antiinflammatory controller medication. Management of intermittent asthma is short-acting inhaled  $\beta$ -agonist as needed for symptoms and for pre-treatment for those with exercise-induced bronchospasm (Step 1). The type(s) and amount(s) of daily controller medications to be used are determined by the asthma severity and control rating. Even for young children, the preferred treatment for 'persistent asthma' is daily ICS therapy, with or without an additional medication. Alternative medications for Step 2 include a leukotriene receptor antagonist (montelukast) or a nonsteroidal antiinflammatory agent (cromolyn). For young children (≤4 years of age) with moderate and severe persistent asthma, medium-dose ICS monotherapy is recommended and combination therapy of medium-dose ICS plus either a long-acting  $\beta$ -agonist (LABA) or montelukast is to be initiated only as a Step 4 treatment for uncontrolled asthma.

Children with severe persistent asthma (Treatment Steps 5 and 6) should receive high-dose ICS, a LABA or montelukast, and an oral corticosteroid, if required. A rescue course of systemic corticosteroids may be necessary at any step.

The 'step-up, step-down' approach initially introduced in the earlier versions of the NAEPP guidelines<sup>21</sup> and slightly modified in the current iteration<sup>6</sup> is discussed in further detail in Chapter 29. The NAEPP guidelines emphasize initiating higher-level controller therapy at the outset to establish prompt control, with measures to 'step down' therapy once good asthma control is achieved. Initially, airflow limitation and the pathology of asthma may limit the delivery and efficacy of ICS such that stepping up to higher doses and/or combination therapy may be needed to gain asthma control. Asthma therapy can be stepped down after good asthma control has been achieved and ICS has had time to achieve optimal efficacy, by determining the least number or dose of daily controller medications that can maintain good control, thereby reducing the potential for medication adverse effects. If step-up therapy is being considered at any point, it is important to check delivery device technique and adherence, implement environmental control measures and identify and treat co-morbid conditions.

The GINA 2014 global strategy also now offers a stepwise approach in the long-term management of asthma in very young children.<sup>7</sup> However, if control is still inadequate despite 3 months of controller therapy, the following should be addressed before any step-up treatment is offered: that any

TABLE  
32-2

Assessing Asthma Control and Adjusting Therapy in Children Aged 0 to 4 Years

Components of Control		CLASSIFICATION OF ASTHMA CONTROL (0–4 YR)		
		Well Controlled	Not Well Controlled	Very Poorly Controlled
Impairment	Daytime symptoms	≤2 d/wk but not more than once on each day	>2 d/wk	Throughout the day
	Nighttime awakenings	≤1×/mo	>1×/mo	>1×/wk
	SABA use for symptoms (not EIB pretreatment)	≤2 d/wk	>2 d/wk	Several times per day
	Interference or limitations with normal activity	None	Some limitation	Extremely limited
Risk	Exacerbations requiring oral systemic corticosteroids	0–1/yr	2–3/yr	>3 yr
	Treatment-related adverse effects	Medication side-effects can vary in intensity from none to very troublesome and worrisome. The level of intensity does not correlate to specific levels of control but should be considered in the overall assessment of risk		
Recommended action for treatment per NAEPP guidelines		Maintain current treatment Regular follow-up every 1–6 months Consider step down if well controlled for at least 3 months	Step up (1 step) and reevaluate in 2–6 weeks If no clear benefit in 4–6 weeks, consider alternative diagnoses or adjusting therapy For side-effects, consider alternative treatment options	Consider short course of oral systemic corticosteroids Step up (1–2 steps), and reevaluate in 2 weeks If no clear benefit in 4–6 weeks, consider alternative diagnoses or adjusting therapy For side-effects, consider alternative treatment options

National Asthma Education and Prevention Program: Expert Panel Report 3 (EPR 3): Guidelines for the Diagnosis and Management of Asthma – Summary Report 2007. Available at: <http://www.nhlbi.nih.gov/guidelines/asthma/asthgdln.htm>.

#### Notes:

- The stepwise approach is meant to assist, not replace, the clinical decision-making required to meet individual patient needs.
- The level of control is based on the most severe impairment or risk category. Assess impairment domain by caregiver's recall of previous 2 to 4 weeks. Symptom assessment for longer periods should reflect a global assessment such as inquiring whether the patient's asthma is better or worse since the last visit.
- At present, there are inadequate data to correspond frequencies of exacerbations with different levels of asthma control. In general, more frequent and intense exacerbations (e.g. requiring urgent, unscheduled care, hospitalization or ICU admission) indicate poorer disease control. For treatment purposes, patients who had ≥2 exacerbations requiring oral systemic corticosteroids in the past year may be considered the same as patients who have not-well-controlled asthma, even in the absence of impairment levels consistent with not-well-controlled asthma.
- Before step-up therapy:
  - Review adherence to medications, inhaler technique and environmental control.
  - If alternative treatment option was used in a step, discontinue it and use preferred treatment for that step.

other possible alternative or confounding condition is entertained; assessment of inhaler technique; adherence is acceptable; and exposure to allergens or tobacco smoke is avoided. The criteria for 'well controlled', 'partly controlled' and 'uncontrolled' asthma according to the GINA global strategy are summarized in Table 32-3, based on a 4-week recall. 'Well-controlled' asthma is characterized by at most daytime symptoms once a week, rescue/reliever treatment less than 2 times a week, absence of any activity limitation due to asthma, and no nocturnal cough or awakenings. 'Partly controlled' asthma has one to two of the following: ≥2 daytime symptoms a week, ≥2 rescue bronchodilator use, any nocturnal cough/awakenings, or limitations of activities. Lastly, 'uncontrolled' asthma is defined as presence of three or all features characteristic of 'partly controlled' asthma present in any week or exacerbation occurring once in any week.

The stepwise approach in the GINA 2014 global strategy has important differences from the NAEPP EPR3<sup>6,7</sup> (Table 32-4). For Step 1 which recommends as needed short-acting β-agonist as the preferred controller choice for children with infrequent viral wheezing, with few or no interval symptoms, intermittent inhaled corticosteroid therapy is an alternative option if short-acting β-agonist treatment is not enough.<sup>46,47</sup> Intermittent

high-dose ICS therapy given at the onset of a respiratory illness is further demonstrated to be as beneficial as maintenance therapy with ICS in children with recurrent wheezing and with risk factors for persistent asthma.<sup>48</sup> Because it has the potential to cause side-effects if given quite often during the year at higher doses, this should be considered for families who are able to use this intervention responsibly. Step 2 treatment is recommended for young children with symptom pattern consistent with asthma and not well controlled *or* with 3 or more exacerbations per year *or* with frequent wheezing episodes occurring every 6 to 8 weeks. Similar to the NAEPP EPR3 recommendation are the preferred medication using daily low-dose ICS (for at least 3 months trial) and the alternative option using a leukotriene receptor antagonist, but GINA 2014 global strategy now also includes intermittent ICS for Step 2 as an alternate option. The National Institute of Health sponsored AsthmaNet is currently undertaking a clinical trial comparing these three treatments in young children with persistent asthma. Preferred Step 3 treatment is double 'low-dose' ICS, indicated for children with established asthma not well controlled on low-dose ICS. The alternative option is low-dose ICS with a leukotriene receptor antagonist. The highest step (Step 4) basically proposes a referral to a specialist for expert advice. Additional options





TABLE  
32-3

## GINA Assessment of Asthma Control in Children 5 Years and Younger

A. Level of Symptom Control		Yes	No
	In the past 4 weeks, has the child had:		
	Daytime asthma symptoms for more than a few minutes?		
	Any night waking or coughing due to asthma?		
	Reliever medication needed more than once a week (excludes reliever taken before exercise)?		
	Any activity limitation due to asthma? (Runs/plays less than other children, tires easily during walks/playing?)		
Controlled (none of the above)			
Partly controlled (1–2 of these)			
Uncontrolled (3–4 of these)			
B. Future Risk for Poor Asthma Outcomes			
Risk factors for asthma exacerbations			
<ul style="list-style-type: none"> <li>• Uncontrolled asthma symptoms</li> <li>• One or more severe exacerbations in previous year</li> <li>• The start of the child's usual 'flare-up' season (especially if autumn or fall)</li> <li>• Exposures: tobacco smoke; indoor or outdoor air pollution; indoor allergens (e.g. house dust mite, cockroach, pets, mold), especially in combination with viral infection</li> <li>• Major psychological or socioeconomic problems for child or family</li> <li>• Poor adherence with controller medication, or incorrect inhaler technique</li> </ul>			
Risk factors for fixed airflow limitation			
<ul style="list-style-type: none"> <li>• Severe asthma with several hospitalizations</li> <li>• History of bronchiolitis</li> </ul>			
Risk factors for medication side-effects			
<ul style="list-style-type: none"> <li>• Systemic: frequent courses of oral corticosteroids; high-dose and/or potent inhaled corticosteroids</li> <li>• Local: moderate/high-dose or potent inhaled corticosteroids; incorrect inhaler technique; failure to protect skin or eyes when using inhaled corticosteroids by nebulizer or spacer with facemask</li> </ul>			

Adapted from the *Global strategy for asthma management and prevention 2014*. Available at: <http://www.ginasthma.org>.

TABLE  
32-4

## Stepwise Approach to Long-Term Management of Asthma in Children 5 Years and Younger (Global Initiative for Asthma 2014)

	Step 1	Step 2	Step 3	Step 4
PREFERRED CONTROLLER CHOICE		Daily low-dose ICS	Double 'low-dose' ICS	Continue controller and refer for specialist assessment
Other controller options		LTRA Intermittent ICS	Low-dose ICS + LTRA	Add LTRA Increase ICS frequency Add intermittent ICS
RELIEVER	As needed short-acting $\beta_2$ -agonist			
CONSIDER THIS STEP FOR CHILDREN WITH	Infrequent viral wheezing and no or few interval symptoms	Symptom pattern consistent with asthma and asthma symptoms not well controlled, or $\geq 3$ exacerbations per year Symptom pattern not consistent with asthma but wheezing episodes occur frequently, e.g. every 6–8 weeks Give diagnostic trial for 3 months	Asthma diagnosis, and not well controlled on low-dose ICS First check diagnosis, inhaler skills, adherence, exposures	Not well controlled on double ICS
KEY ISSUES	ALL CHILDREN <ul style="list-style-type: none"> <li>• Assess symptom control, future risk, co-morbidities</li> <li>• Self-management: education, inhaler skills, written asthma action plan, adherence</li> <li>• Regular review: assess response, adverse events, establish minimal effective treatment</li> <li>• (Where relevant): environmental control for smoke, allergens, indoor/outdoor air pollution</li> </ul>			

Adapted from the *Global strategy for asthma management and prevention 2014*. Available at: <http://www.ginasthma.org>.

ICS – Inhaled corticosteroid; LTRA – leukotriene receptor antagonist.

diagnostic accuracy of 81% and 78%, respectively. Based on the highest area under the ROC curve, a score of less than 80 provided the best cut-off between sensitivity and specificity for uncontrolled asthma for this group. The pediatric version of the Asthma Control Test (cACT) has been validated for children as young as 4 years of age.

The GINA 2014 global strategy assessment of asthma control is discussed in an earlier section and summarized in Table 32-3.

### Inhaled Corticosteroids

ICS are the preferred controller therapy for persistent asthma or asthma that is not controlled. Although there are six ICS available, nebulized budesonide is the only US Federal Drug Administration (FDA)-approved ICS for children less than 4 years of age. The initial studies with nebulized budesonide in young children with moderate to severe persistent asthma found it to be superior to placebo in improving symptoms, decreasing exacerbations, reducing chronic oral prednisone use or improving overall asthma control.<sup>52,53</sup>

Studies have also evaluated the efficacy and safety of nebulized budesonide in children with mild to moderate persistent asthma.<sup>54–56</sup> The efficacy of nebulized budesonide over placebo was consistently demonstrated with improvement in symptom scores, reduction in rescue medication use and improvement in morning peak expiratory flow rates in patients who could adequately perform the procedure. Improvement in symptom scores occurred as early as 2 weeks after starting budesonide.<sup>56</sup> Twice-daily dosing of 0.5 mg appeared to be somewhat more effective than 1 mg administered once daily. The investigators suggested that a dose of 0.25 mg/day may be sufficient for mild asthma, whereas subjects with moderate asthma should be treated with 0.5 to 1 mg/day and those with severe asthma dependent on oral steroids should be treated with 1–2 mg/day. No significant differences in basal cortisol levels or

ACTH-stimulated cortisol levels were found between any of the active treatment groups and placebo.

**Pharmacokinetics of Nebulized Budesonide in Small Children.** Little is known regarding the amount of drug delivered, by any inhaled device and with any drug, to infants and young children with asthma. ICS have the potential for adverse effects, so it is important to deliver the smallest amount of drug required for response. Agertoft et al evaluated the systemic availability and pharmacokinetics of nebulized budesonide in a group of preschool children (mean age 4.7 years) with chronic asthma.<sup>57</sup> Ten children underwent pharmacokinetic studies of both intravenously administered (125 µg) and inhaled budesonide (1 mg delivered by nebulization). The amount of nebulized budesonide delivered to the patient was calculated by subtracting the amount of drug remaining in the nebulizer, the amount emitted into the ambient air, and the amount found in the mouth after rinsing from the initial amount of budesonide in the nebulizer (the nominal dose). The mean dose to the subject was found to be 23% of the nominal dose (231 µg), while the systemic availability was only 6.1% of the nominal dose, or 61 µg. The clearance of budesonide was calculated to be 0.54 L/min with a  $t_{1/2}$  of 2.3 hours, and  $V_{dss}$  of 55 L. The systemic availability in these small children was approximately half that seen in adults. In addition, the clearance of budesonide in these children was twice that of adults.

Recommended doses of different ICS formulations for children 5 years and younger according to low, medium and high doses in the NAEPP EPR3 and low-dose formulations in the GINA 2014 global strategy are shown in Table 32-5.<sup>6,7</sup>

What type of patient will respond favorably to ICS in this age group is an important question that has yet to be answered. A study by Roorda et al using data from two large placebo-controlled studies evaluated the clinical features of preschool children likely to respond to fluticasone administered via a

**TABLE 32-5** Estimated Comparative Inhaled Corticosteroid Doses

Drug	NAEPP EPR3 <sup>†</sup>			GINA 2014 <sup>*</sup>
	Low	Medium	High	Low
Beclomethasone HFA, 40 or 80 µg/puff	NA	NA	NA	100 µg
Budesonide DPI 90, 80 or 200 µg/inhalation	NA	NA	NA	
Budesonide pMDI + spacer	NA	NA	NA	200 µg
Budesonide inhaled suspension for nebulization, 0.25-, 0.5- and 1.0-mg dose	0.25–0.5 mg	>0.5–1.0 mg	>1.0 mg	500 µg
Ciclesonide HFA/pMDI, 80 or 160 µg/puff				160
Flunisolide, 250 µg/puff	NA	NA	NA	
Flunisolide HFA/pMDI, 80 µg/puff	NA	NA	NA	
Fluticasone HFA/pMDI, 44, 110 or 220 µg/puff	176 µg	>176–352 µg	>352 µg	100
Fluticasone DPI, 50, 100 or 250 µg/inhalation	NA	NA	NA	
Mometasone DPI, 220 µg/inhalation	NA	NA	NA	Not studied below age 4 years
Triamcinolone acetonide, 75 µg/puff	NA	NA	NA	Not studied in this age group

<sup>\*</sup>Only low doses are given. This is not a table of clinical equivalence. A low daily dose is defined as the dose that has not been associated with clinically adverse effects in trials that included measures of safety. Adapted from the GINA global strategy for asthma management and prevention 2014. Available at: <http://www.ginasthma.org>.

<sup>†</sup>Adapted from the National Asthma Education and Prevention Program: Expert Panel Report 3 (EPR 3): Guidelines for the Diagnosis and Management of Asthma – Summary Report 2007. J Allergy Clin Immunol 2007;120(Suppl):S94–138. Available at: <http://www.nhlbi.nih.gov/guidelines/asthma/asthgdln.htm>.

HFA – Hydrofluoroalkane propellant; pMDI – pressurized metered dose inhaler.

pressurized metered dose inhaler (pMDI) with holding chamber and facemask.<sup>58</sup> The investigators identified two clinical features that predicted a positive response to ICS therapy – frequent symptoms ( $\geq 3$  days/week) and a family history of asthma. The presence of eczema and the number of previous acute exacerbations were not associated with response to fluticasone. Eczema predisposes a child with recurrent wheezing to subsequent asthma,<sup>14</sup> but it does not appear to predict response to ICS therapy. It should be noted that a lack of response over a short course of treatment (12 weeks) does not necessarily mean that a response would not be seen over a much longer period of time (months to years). An NHLBI-sponsored AsthmaNet clinical trial which will be completed in 2015 is evaluating predictors of response to different interventions, specifically daily vs intermittent ICS therapy vs leukotriene receptor antagonist, in preschool aged children with persistent asthma.<sup>59</sup>

The clinical efficacy and safety of intermittent ICS or systemic corticosteroid for young children with associated upper respiratory infection or viral induced wheeze remain controversial. A 2009 study which evaluated ‘as needed’ high-dose fluticasone propionate (750  $\mu\text{g}$  twice daily) given at the onset of an upper respiratory tract illness found lower rescue oral corticosteroid use in those on active treatment compared to placebo (8% vs 18%, respectively); however this was accompanied by a statistically significant difference in height and weight gain.<sup>46</sup> In another 2009 study, oral prednisolone was found not to be superior to placebo with respect to duration of hospitalization, clinician and parent symptom severity assessment, and hospital readmission for preschool children presenting to a hospital with viral-induced mild to moderate wheezing.<sup>60</sup> A 2011 study which evaluated daily vs intermittent high-dose ICS therapy given at the onset of a respiratory illness in preschool aged children with recurrent wheezing and atopic risk factors found no difference between the two treatments with respect to prevention of severe exacerbations.<sup>48</sup>

**ICS and Growth in Small Children.** Few published studies have evaluated the effects of ICS on the linear growth of preschool children. Reid et al, in an open-label study, measured linear growth velocity in 40 children (mean age 1.4 years) before and during treatment with nebulized budesonide.<sup>61</sup> All of the children had ‘troublesome’ asthma despite treatment with an ICS administered with a pMDI with spacer and facemask or nebulized cromolyn before entry into the study. They were then administered 1 to 4 mg/day of nebulized budesonide depending on their level of asthma severity. The median intervals of time for linear growth determinations during the run-in period and nebulized budesonide treatments were 6 months and 1 year, respectively. The height standard deviation scores (SDSs) for the group during the run-in period were  $-0.21$ , at baseline  $-0.46$ , and after at least 6 months of nebulized budesonide  $-0.17$ . Note that an SDS of less than 0 denotes impaired growth velocity. Thus the subjects were growing at less than an impaired rate before nebulized budesonide therapy, and the institution of nebulized budesonide did not result in further growth suppression. In fact, there was a trend toward improved growth velocity while on nebulized budesonide.

Skoner et al<sup>62</sup> evaluated the growth of children enrolled in 52-week open-label extension studies of the three efficacy studies of budesonide.<sup>54–56</sup> The dose of budesonide was either 0.5 mg once or twice daily with a taper to the lowest tolerated

dose, and conventional asthma therapy consisted of any available therapy including ICS in two of the studies; in total, 670 children participated. The investigators found a modest impairment in growth in only one of the three extension studies. The extension study where a decline in growth was noted consisted primarily of young children with milder asthma who had not been on ICS before entry into the initial study. In contrast, the two extension studies that did not find growth impairment consisted of children with more severe disease and had allowed for ICS use as part of the conventional asthma therapy algorithm. The Skoner study suggests that modest growth suppression can occur in young children receiving nebulized budesonide who have not required ICS therapy in the past and that children with milder asthma may be at greater risk for growth suppression secondary to increased intrapulmonary deposition. Alternatively, the findings may be attributable to the fact that over twice as many children randomized to the conventional asthma therapy arm withdrew from the study because of poor asthma control.

The PEAK and IFWIN studies which used ICS via MDI with a holding chamber and mask have also provided important findings on the adverse effects of long-term ICS on growth in preschool children at risk for persistent asthma.<sup>19,63,64</sup> It is still uncertain if there is a potential for catch up or if the effects in very young children are cumulative. A follow-up study of PEAK participants 2 years after the clinical trial was completed showed no difference in growth between children who were on active ICS therapy compared to those who were randomized to placebo.<sup>64</sup> However, in a post hoc analysis, lower growth velocity was found among participants who were younger and weighed less, probably due to a relatively greater drug exposure. For young children with poor asthma control, the disease itself can negatively impact growth. The growth of 58 children (mean age 3.5 years for males, 4.4 years for females) with asthma was followed over a 5-year period.<sup>65</sup> Each child’s asthma was classified as being in good, moderate or poor control according to asthma symptoms during a 2-year observational period before the institution of ICS therapy. The group as a whole had diminished growth velocity to start the study, with a mean height velocity standard deviation (HVSD) score of  $-0.51$ . Children whose asthma was in good control had the least evidence for growth suppression before ICS therapy was instituted and continued to grow at the same rate as when on therapy (HVSD score  $-0.01$  pre- vs  $-0.07$  during treatment). In contrast, the subjects whose asthma was poorly controlled grew poorly before and after institution of ICS therapy (HVSD score  $-1.50$  pre- vs  $-1.55$  during treatment). Of interest, those with moderately controlled asthma demonstrated improved growth velocity while on ICS therapy, with their HVSD score increasing from  $-0.83$  to  $-0.49$ . The investigators concluded that poor asthma control adversely impacts linear growth to a greater extent than ICS therapy.

### Alternative and/or Adjunct Medications

The NHLBI NAEPP EPR3 guidelines recommend cromolyn or montelukast as alternative therapy for younger children with mild persistent asthma and combination therapy using ICS plus either LABA or montelukast for younger children with moderate to severe persistent asthma (Steps 4 and 5).<sup>6</sup> GINA 2014 global strategy recommends leukotriene receptor antagonist or increased or intermittent ICS therapy as alternative options for Step 2 and add-on options for Steps 3 and 4.<sup>7</sup>



**Cromolyn.** Cromolyn (Intal) inhibits mediator release from mast cells. It inhibits both the early- and late-phase pulmonary components of the allergic response following inhalation of an allergen in sensitized subjects. A few studies have shown no added benefit with the use of cromolyn over placebo in young children with more severe disease.<sup>66–69</sup> Several efficacy studies that have found cromolyn to have beneficial effects were short-term trials and employed small numbers.<sup>70,71</sup> A meta-analysis of 22 control studies evaluating cromolyn in childhood asthma found it no better than placebo.<sup>72</sup> A multicenter, randomized, parallel-group, 52-week, open-label study in preschool children found nebulized cromolyn (20 mg four times daily) ( $N = 335$ ) to be inferior to nebulized budesonide suspension (0.5 mg daily) ( $N = 168$ ) using several outcome parameters.<sup>73</sup> Children who received inhaled budesonide suspension had a reduced rate of asthma exacerbations per year, longer time to first asthma exacerbation and first use of additional long-term controller therapy; nearly doubled improvements in nighttime and daytime symptom scores by the second week of treatment; and lower use of rescue medications. Although there were no significant differences in the rates of hospitalization and emergency room visits between the two groups, significantly lower urgent care or unscheduled physician visits and oral corticosteroid use were found in children who received the ICS. However, mean height increases from baseline in children randomized to inhaled budesonide and inhaled cromolyn were 6.69 and 7.55 cm, respectively. This difference of 0.86 cm is similar to the difference in height measurements seen in other studies with ICS therapy after 1 year of treatment in both younger and older children.<sup>19,74,75</sup>

**Leukotriene Modifying Agents.** Leukotrienes are potent pro-inflammatory mediators that induce bronchospasm, mucus secretion and airway edema. In addition, they may be involved in eosinophil recruitment into the asthmatic airway.<sup>76</sup> Leukotriene modifiers (synthesis inhibitor or receptor antagonist) have beneficial effects in terms of reducing asthma symptoms and supplemental  $\beta$ -agonist use while improving baseline pulmonary function.<sup>77–79</sup> The leukotriene receptor antagonists (LTRA) prevent the binding of LTD<sub>4</sub> to its receptor. This class has a pediatric indication and includes both montelukast (given once daily; has been approved for treatment of chronic asthma for children age 1 year and older) and zafirlukast (administered twice daily; approved for children 7 years and older).

Safety and efficacy studies with the 4-mg chewable montelukast tablet in children aged 2 to 5 years with asthma have been published.<sup>80–82</sup> Almost 700 children 2 to 5 years of age were enrolled to receive montelukast or placebo for 12 weeks in a double-blind, multicenter, multinational study at 93 centers worldwide.<sup>80</sup> Montelukast was well tolerated and was not associated with any significant adverse effects. Montelukast was superior to placebo in reducing daytime symptoms including improvements in cough, wheeze, difficulty breathing and activity level, and nighttime cough. In addition, montelukast therapy was associated with a reduction in rescue  $\beta$ -agonist use and reduced need for prednisone for acute severe exacerbations.

Studies have been done to evaluate the long-term effects of an LTRA (continuous<sup>81</sup> and intermittent<sup>82</sup>) on the occurrence of exacerbations in young children. In a 12-month, double-blind, parallel study which was designed to investigate the role of montelukast in the prevention of viral induced asthma exacerbations in children aged 2 to 5 years with a history of intermittent asthma symptoms, montelukast significantly reduced

the rate of asthma exacerbations by 31.9% compared with placebo. Montelukast delayed the median time to first exacerbation by approximately 2 months and the rate of ICS courses compared to placebo.<sup>81</sup> In another study, 220 children aged 2 to 14 years were randomized to receive either intermittent montelukast or placebo at the onset of asthma or upper respiratory tract infection symptoms for a minimum of seven days.<sup>82</sup> The montelukast group had 163 unscheduled health care resource utilizations for asthma compared with 228 in the placebo group (OR = 0.65, 95% CI 0.47–0.89). There was a nonsignificant reduction in specialist attendances and hospitalizations, duration of episode and  $\beta$ -agonist and prednisolone use. These studies suggest that intermittent or persistent therapy with montelukast for children with intermittent asthma symptoms is effective in reducing risk of exacerbations compared with placebo.

**Long-acting Inhaled  $\beta$ -Agonists.** LABAs are the alternative add-on therapy for children and adults with moderate and severe persistent asthma. The GINA 2014 global strategy does not include LABAs as controller therapy in any of their stepwise algorithms for very young children.<sup>7</sup> They are not viewed as ‘rescue’ medications for acute episodes of bronchospasm, nor are they meant to replace inhaled anti-inflammatory agents. Salmeterol has a prolonged onset of action with maximal bronchodilation approximately 1 hour following administration; formoterol has an onset of effect within minutes. Both medications have a prolonged duration of action of at least 12 hours. As such, they are especially well suited for patients with nocturnal asthma<sup>83</sup> and for individuals who require frequent use of short-acting  $\beta$ -agonist inhalations during the day to prevent exercise-induced asthma.<sup>84</sup> There is an added advantage to the use of these alternative therapies for preschool children who may deserve an extended bronchodilatory coverage for exercise because they are constantly active. Salmeterol via the Diskus™ device is FDA approved for children as young as 4 years of age (50  $\mu$ g blister every 12 hours), whereas formoterol delivered via the Aerolizer™ is approved for use in children 6 years of age and older (12  $\mu$ g capsule every 12 hours). Both LABAs are also available as combination pMDI with an ICS (salmeterol and fluticasone [Advair], budesonide and formoterol [Symbicort], and mometasone and formoterol [Dulera]). Although LABAs combined with ICS are recommended for young children in Steps 4 to 6 of the NAEPP EPR3 guidelines (Figure 32-2), they have limited application.<sup>6</sup> The Diskus™ combination product is FDA approved down to 4 years of age but its use requires adequate inspiratory effort to get an optimal delivery of the dry powder. While the pMDI can be used with a holding chamber, it is not currently approved for children younger than 12 years of age. The efficacy and safety of LABA or combination products in younger children with asthma are still uncertain due to lack of studies.

The FDA has requested the manufacturers of LABAs to update their product information warning sections regarding an increase in severe asthma episodes associated with these agents. This action is in response to data showing an increased number of asthma-related deaths in patients receiving LABA therapy in addition to their usual asthma care as compared with patients not receiving LABAs.

Treatment immediately prior to vigorous activity or exercise is usually effective. The combination of a SABA with either cromolyn or nedocromil is more effective than either drug

alone. Montelukast may be effective for up to 24 hours. Salmeterol and formoterol may block exercise-induced bronchospasm for up to 12 hours. There is one study that has evaluated single-dose bronchoprotective effects of salmeterol given through a Babyhaler spacer device using a methacholine provocation challenge in infants less than 4 years old with recurrent episodes of wheezing.<sup>85</sup> Originally 42 preschool children (age range 8 to 45 months) received one of the 25-, 50- or 100- $\mu$ g dose of salmeterol and a placebo dose 2 to 7 days apart in a double-blind, randomized fashion, but only 33 completed the study. The investigators found a dose-dependent bronchoprotective effect of salmeterol measured by treatment/placebo methacholine dose ratios. Significant improvements from placebo were found only for the 50 (2.5 fold) and 100 (fourfold)  $\mu$ g doses.

### ISSUES RELATED TO THE DELIVERY OF MEDICATIONS TO INFANTS AND SMALL CHILDREN

There are unique challenges relating to the delivery of medications (both oral and inhaled) to infants and young children with asthma. Obviously, liquid preparations are tolerated by infants but chewable tablets/pills can already be consumed by toddlers. Montelukast is available as oral granules or chewable tablet and prednisone/prednisolone comes in either liquid formulations or orally disintegrating tablet preparations. With regard to inhaled medications, certain anatomic and physiologic characteristics of children younger than 6 years are worth considering. First, because infants display preferential nasal breathing and have small airways, low tidal volume and high respiratory frequency, delivery of the drug to the lower airways is often inadequate.<sup>86</sup> Second, it is difficult if not impossible for young children to perform the maneuvers specified for optimal delivery of aerosol therapy such as slow inhalation through the mouth with a period of breath-holding for pMDIs or rapid and forceful inhalation required in the case of dry-powder inhalers (DPIs). Third, delivery devices appropriate for the young child are limited to those that require minimum cooperation from the child and must allow ease of administration for the caregivers. Although at present there are at least three inhaled aerosol delivery systems available for older children and adults, only two are used in this age group: the nebulizer and the pMDI with spacer/holding chamber and facemask. Because of the reliance on the subject's ability to generate a sufficient inspiratory flow and overcome the resistance required of DPIs, preschool age children are unable to use them.

Within these two general types of delivery systems there are numerous products available that vary widely in performance. The pMDI with spacer or holding chamber is portable and inexpensive, takes less time to administer and is likely to be better tolerated than delivery with a nebulizer. Dolovich et al<sup>87</sup> published a comprehensive systematic review to determine if device selection affects clinical efficacy and safety. Randomized placebo-controlled trials that involved various devices for the delivery of  $\beta$ -agonists, ICS and anticholinergic agents in different clinical settings (emergency department, inpatient, intensive care and outpatient) and patient populations (pediatric and adult asthma, and COPD) were included. Reports in which the same drug was delivered with different devices were analyzed. Their findings indicated that the drugs delivered via different formats are equally effective. Appropriate

technique, cooperation and convenience determine which delivery may be best.

Asthma clinical guidelines mention the use of inhaled short-acting  $\beta$ -agonist either by pMDI or nebulizer as an initial asthma exacerbation home intervention.<sup>6,7</sup> The GINA global strategy recommends the use of short-acting inhaled  $\beta$ -agonist by pMDI (ideally with a spacer) for home management of mild, moderate and severe exacerbations. GINA also recommends nebulized treatments for severe exacerbations at home and for hospital-based management of acute asthma.<sup>7</sup>

Data in young children clearly support the use of  $\beta$ -agonists, at higher doses, administered via a pMDI with spacer for acute asthma.<sup>88,89</sup> In a study of 60 children between 1 and 5 years of age hospitalized for an asthma exacerbation, Parkin et al found salbutamol (400 to 600  $\mu$ g, 4 to 6 puffs, based on weight) and ipratropium bromide (40  $\mu$ g, 2 puffs), both delivered via pMDI with an Aerochamber and mask, to be as effective as nebulized salbutamol (0.15 mg/kg) and ipratropium bromide (125  $\mu$ g) administered over 15 minutes by facemask.<sup>88</sup> However, nearly one third of the subjects randomized to MDI eventually required a nebulized  $\beta$ -agonist.

Two studies have evaluated lower respiratory tract deposition of a radiolabeled salbutamol/albuterol mixture administered to young children. Tal et al showed that on average, less than 2% of the nominal dose of the albuterol given by a pMDI with a spacer and mask to children less than 5 years old was deposited in the lower respiratory tract with most of the drug remaining in the spacer.<sup>90</sup> Wildhaber et al compared the lung deposition of radiolabeled salbutamol from a nebulizer and a pMDI and spacer in 17 asthmatic children aged 2 to 9 years.<sup>91</sup> Both devices were delivering roughly 5% of the nominal dose to the lower airways. Because of the larger doses of salbutamol administered via the nebulizer (2,000  $\mu$ g vs 400  $\mu$ g) than the pMDI, a larger amount of drug was deposited in the airways using the nebulizer (108  $\mu$ g vs 22  $\mu$ g, respectively). In addition, both devices were approximately 50% less efficient in children less than 4 years old than in older children.

In general,  $\beta$ -agonist administration by nebulization is still probably a more practical delivery system for most infants and young children with severe acute asthma because it requires the simple technique of relaxed tidal breathing, particularly if it is difficult to use a tight fitting spacer and mask for a pMDI. In addition, oxygen can be used to power the nebulizer, providing  $\beta$ -agonist and supplemental oxygen simultaneously, and it does offer the capability to administer a controller agent and rescue  $\beta$ -agonist at the same time.

With respect to controller therapy, the only available inhaled drugs that are FDA approved for children under 4 years of age are cromolyn solution and budesonide suspension intended for nebulization. However, a pMDI with a spacer device is certainly more convenient and easier to administer. The GINA global strategy prefers the administration of ICS via a pressurized metered dose inhaler (pMDI) with a spacer and either a facemask (for 0 to 3 years of age) or a mouthpiece (for  $\geq 4$  years old) for young children with asthma but the dose delivered is variable between spacers.<sup>7</sup> These guidelines mention the use of nebulizers as an alternative delivery system for children who are unable to use the spacer device effectively. Since young children are only expected to perform tidal breathing, the optimal number of breaths to empty the spacer device varies with the tidal volume, dead space and volume of the device. Important measures to maximize delivery of medication to very young

children include the following: enforcing a tight fitting mask around the child's mouth and nose, encouraging immediate inhalation after actuation, allowing 5 to 6 breaths per single pMDI actuation, making sure that the spacer valve is moving when the child is breathing through the spacer, shaking the inhaler in between actuations and using a lower volume spacer (<350 mL) in these very young children.

The Montreal Protocol, adopted in 1987, mandated a complete elimination of the chlorofluorocarbon (CFC) propellant due to concerns about its damaging effect on the ozone layer. Since 2008, pMDIs now contain hydrofluoroalkane (HFA). However, the pMDI HFAs (even rescue short-acting  $\beta$ -agonists) are approved for use only in children 4 years of age and older. There is no information available on the relationship between lung deposition from HFA pMDI and clinical efficacy or even long-term safety in small children. In addition, no studies exist comparing inhaled medications administered via nebulizer and HFA pMDI with spacer and mask.

Additional factors that should be considered are the costs to the patient (including use of spacer attachments which are not reimbursable) and the use of multiple delivery devices which requires more time for the clinician staff to educate families on proper techniques. To address both issues, perhaps the same type of device can be used for all inhaled drugs for an individual patient. The decision should also incorporate which device the clinician is capable of teaching properly and what the patient/parent prefers. When a child presents with uncontrolled asthma, the assessment should first focus on technique and adherence.

## ADHERENCE

The issue of adherence in infants and small children is complicated because the child is entirely dependent on the caregiver to administer the medication. In an observational study of preschool children, Gibson et al sought to evaluate adherence with inhaled prophylactic medications delivered through a large volume spacer using an electronic timer device. Adherence was only 50% with a range of 0% to 94%.<sup>92</sup> In addition, only 42% of the subjects received the prescribed medication on each study day, and reporting of symptoms in the diary cards did not correlate with good compliance with the prophylactic medication, nor was a correlation found between frequency of administration and adherence. In another study, parental reporting of symptom scores correlated with measured bronchodilator use in only 63% of preschool children.<sup>93</sup>

A few studies have attempted to determine why caregivers are unable to administer medications as prescribed. Lim et al asked parents why they were reluctant to administer prophylactic medications (such as ICS) to their young children with asthma. Reasons cited included hesitancy to use medications for fear of dependence, side-effects and overdose.<sup>94</sup> Fortunately, patient education programs developed for parents of small children with asthma improve asthma morbidity and self-management outcome.<sup>95,96</sup>

## NONPHARMACOLOGIC INTERVENTION

Nonpharmacologic measures may be as important not only for young children with established respiratory symptoms, allergies and passive smoke exposure but also in the primary and

secondary prevention of asthma.<sup>97-99</sup> The first and likely the most important step toward controlling asthma in sensitized children is to avoid or reduce the patient's exposure to the offending allergen. The environmental interventions that seem to hold the most promise are those that target reducing exposure to indoor allergens and tobacco smoke. Specific environmental control measures are covered in Chapter 21.

Yearly influenza immunization is also strongly recommended for children 6 months of age and older with chronic pulmonary diseases, including asthma. Kramarz et al evaluated the effectiveness of influenza vaccination in preventing influenza-related asthma exacerbations in children 1 to 6 years of age using a retrospective cohort study with the Vaccine Safety Datalink, which contains data on more than 1 million children enrolled in four large health maintenance organizations.<sup>100</sup> Of note, less than 10% of children with asthma were vaccinated against influenza in any of the years studied. Although the incidence rates of asthma exacerbation in those who were vaccinated were found to be higher in the vaccinated group than in those who were not vaccinated, the difference was thought to be largely confounded by asthma severity in the vaccinated group. Using a 'self-control' analysis to correct for this confounder, the risks of asthma exacerbation during each of the influenza seasons were reduced by 22% to 41% with influenza vaccination.

## Management of Asthma Exacerbations in Young Children

Exacerbations, also commonly referred to as episodes or flare-ups, are acute deterioration of asthma control characterized by increased symptom severity, sudden change in child's activity or performance (lethargy or lack of interest or exercise intolerance), poor response to or sudden increased need for rescue medication, and breathing difficulty or respiratory distress at its worst. In this age group, these are often preceded by upper respiratory symptoms or viral syndrome. The most effective approach in managing asthma exacerbations involves early recognition of warning signs and early treatment. An action plan should be provided to the family members or caregivers which includes information about what medications to give, medical provider's contact information and when to seek urgent medical attention (such as signs of acute distress, symptoms unrelieved by bronchodilator, increased need for rescue treatment or repeated use of bronchodilator over several hours).<sup>7</sup> A copy should also be given to daycare providers and school personnel.

## HOME MANAGEMENT

Early treatment of asthma exacerbations may prevent a life-threatening event or a hospital admission. Initial treatment should be with a SABA (e.g. albuterol or levalbuterol): 2 puffs from an MDI via a spacer device with or without a facemask, which may be repeated every 20 minutes 2 more times, or a single treatment can be given by nebulizer (0.05 mg/kg [minimum dose, 1.25 mg; maximum, 2.5 mg] of 0.5% solution of albuterol in 2-3 mL saline; or 0.075 mg/kg [minimum dose, 1.25 mg; maximum, 5 mg] of levalbuterol).<sup>6</sup> If the response is good as assessed by sustained symptom relief, the SABA can be continued every 3 to 4 hours for 24 to 48 hours. Patients should



be advised to seek medical care once excessive doses of bronchodilator therapy are used or for prolonged periods (e.g. >6 puffs of inhaled SABA are used within the first 2 hours, >12 puffs/day for >24 hours, or if the child has not recovered after 24 hours).<sup>6,7</sup>

If the child does not completely improve with the initial therapy, the SABA should be continued and the caregiver should contact the physician urgently. If the child experiences marked distress, the caregiver should give the SABA immediately and bring the patient to the emergency department or call 9-1-1 or another emergency number for assistance. Intensification of acute treatment with an oral corticosteroid initiated by family members can be considered but evidence for its early use is debatable.<sup>101</sup> Doubling the dose of inhaled corticosteroids is not proven sufficient to prevent worsening of exacerbations. However, recent studies in small children not on regular controller therapy have shown benefits from using high-dose ICS at the early onset of a respiratory illness in preventing the need for systemic corticosteroid.<sup>46,48</sup> One study has shown the efficacy of starting a short course of montelukast at the onset of a respiratory tract illness in small children with episodic wheezing with respect to reducing symptom burden, healthcare utilization and time off work,<sup>82</sup> but perhaps this benefit from a short course of leukotriene receptor antagonist at reducing symptom burden may only be expected in young children who have atopic risk factors.<sup>102</sup>

## MANAGEMENT IN THE EMERGENCY DEPARTMENT OR HOSPITAL

Clinical assessment is used, and scoring systems (e.g. Preschool Respiratory Assessment Measure [PRAM] and the Pediatric Asthma Severity Score [PASS]) have been developed to assess the severity of asthma exacerbations.<sup>103</sup> Severe exacerbations are characterized by any one of the following: altered mental state (agitated, confused or drowsy), oxygen saturation <92%; tachycardia (>200 beats/minute for 0 to 3 years old; >180 beats/minute for 4 to 5 years old); retractions; cyanosis; and 'silent' chest (wheeze inaudible).<sup>7</sup> Functional assessment of a young child's degree of airflow limitation is impractical but oxygen saturation should be obtained. Chest radiographs are not recommended routinely but should be considered to rule out pneumothorax, pneumomediastinum, pneumonia or atelectasis.

Initial treatment can be with a SABA by inhaler (albuterol, 4–8 puffs) or nebulizer (0.15 mg/kg of albuterol 0.5% solution; minimum dose 2.5 mg), or nebulized high-dose SABA plus ipratropium bromide (0.25–0.5 mg), up to three doses in the first hour. Oxygen should be given to maintain oxygen saturation above 93%.<sup>6,7</sup>

Systemic corticosteroids (oral prednisolone 1–2 mg/kg/day; maximum of 20 mg/day for <2 years of age, 30 mg for children 2 to 5 years of age, and 60 mg/day for older children or IV methylprednisolone 1 mg/kg every 6 hours)<sup>7</sup> should be instituted if the child responds poorly to therapy at 1 hour or continues to deteriorate or if symptoms recur within 3 to 4 hours or symptoms persist beyond 1 day or if the child has recently been on oral corticosteroids. Sensitivity to adrenergic drugs may improve after initiation of corticosteroids.

If the child shows slow or poor response, continuous bronchodilator treatment for the first hour (0.5 mg/kg/h) can be administered. For older children and adults with severe exacerbation having no response to initial inhaled therapy, or for those

who cannot cooperate with or who resist inhalation therapy, adjunctive therapies include intravenous magnesium sulfate (25–75 mg/kg up to 2 g in children) and heliox driven albuterol nebulization, but their use in younger children is not as established. The use of isotonic magnesium sulfate by nebulization (150 mg, 3 doses in the first hour) as an add-on treatment for children as young as 2 years of age with severe exacerbation was found beneficial for those with more severe presentation in the presence of oxygen saturation <92% and with symptoms lasting less than 6 hours.<sup>104</sup>

For impending or ongoing respiratory arrest, epinephrine 1:1,000 or terbutaline 1 mg/mL (both 0.01 mg/kg up to 0.3–0.5 mg) may be administered subcutaneously every 20 minutes for three doses, although the use of intravenous  $\beta_2$ -agonists is still unproven. Children may need ventilatory support with 100% oxygen, intravenous corticosteroids and admission to an intensive care unit (ICU). Further treatment is based on clinical response and objective laboratory findings.

Hospitalization should be strongly considered for any child with a history of respiratory failure or significant psychosocial impediments to optimal acute asthma care. The decision to hospitalize should also be based on presence of risk factors for mortality from asthma, duration and severity of symptoms, course and severity of previous exacerbations, medication use at the time of the exacerbation, access to medical care, and home and psychosocial conditions. Maintenance fluids and electrolyte requirements (both corticosteroids and  $\beta_2$ -agonists can cause potassium loss) should be provided, especially since these young children are likely to have poor oral intake secondary to respiratory distress or vomiting, but they require intensive monitoring as overhydration may contribute to pulmonary edema associated with high intrapleural pressures generated in severe asthma. Antibiotics may be necessary to treat co-existing bacterial infection.

Criteria for discharging young children home should include a sustained response of at least 1 hour to bronchodilator therapy. The child should also be ambulatory according to age expectation, comfortable, and able to keep food or drink down.<sup>7</sup> Prior to discharge, the caregiver's ability to continue therapy and assess symptoms appropriately needs to be considered since children with a recent exacerbation are at risk of recurrent episodes. The caregiver should be given an action plan for management of recurrent symptoms or exacerbations, identification of triggers and how to avoid them, and instructions about rescue and controller medications and their use. Hospitalized patients should receive more intensive education prior to discharge. This is another opportunity to review inhaler technique. The inhaled SABA and oral corticosteroids should be continued, the latter for 3 to 7 days. Finally, the caregiver should be instructed about the follow-up visit, which typically takes place within 1 week. Referral to an asthma specialist should be considered for all children with severe exacerbations or multiple emergency department visits or hospitalizations.

## Prevention of Asthma

Given the burden of asthma and recurrent wheezing illnesses in young children, with their associated morbidity and healthcare utilization due to risk of severe episodes, not to mention the high direct and indirect costs that go with them, preventive measures are indeed warranted. To have any chance for success,



early intervention will require identifying high-risk infants and establishing effectiveness of the intervention strategy in young children while minimizing the potential for adverse effects. This is discussed in more detail in Chapter 39. Primary prevention is ideal but the right intervention is lacking because of the heterogeneous nature of this condition.

Two studies have evaluated the effects of ketotifen and cetirizine, respectively, in preventing the onset of asthma in genetically prone children.<sup>105,106</sup> In a double-blind, placebo-controlled, parallel study, children up to 2 years of age without a prior history of wheezing but with a family history of asthma or allergic rhinitis and presence of elevated serum IgE were randomized to receive either ketotifen (0.5–1 mg twice daily) ( $N = 45$ , mean age 11.5 months) or placebo ( $N = 40$ , mean age 10.8 months) for 3 years.<sup>43</sup> Only 9% of children on active treatment compared to 35% of the placebo group developed frequent episodes of wheezing during the study period ( $P = .003$ ). The other study, called the Early Treatment of the Atopic Child, was a randomized, double-blind, parallel group trial that compared cetirizine (0.25 mg/kg twice daily) and placebo.<sup>106</sup> The medications were administered for 18 months to infants between 1 and 2 years of age with atopic dermatitis and a family history of atopy. The primary outcome, which was the time to onset of asthma in the next 18 months after discontinuation of treatment, was not different between the two groups. Half the children in both cetirizine and placebo groups developed asthma (defined as three episodes of wheezing during the 36 months of follow-up) ( $P = .7$ ). However, in the cetirizine group, infants with evidence of dust mite or grass pollen sensitivity were less likely to have asthma over the 18 months of treatment with a sustained effect for grass-sensitized infants over the 36 months of follow-up compared with those treated with placebo. Furthermore, in the placebo group there was an increased risk of developing asthma in those with baseline sensitivity to egg, house dust mite, grass pollen or cat allergen. These two studies support the role of easily administered preventive measures in delaying or even preventing the development of asthma in genetically predisposed children.

Various other prevention modalities have shown promising potential to modulate asthma development. Given the relevance of environmental and allergen exposure in airway inflammation characteristic of asthma, interventions that can reduce these exposures (e.g. reducing tobacco smoke, dust mite or pet avoidance, and dietary modifications) have been undertaken, with modest overall results, and applicability may be limited by location and individual exposures.<sup>107–116</sup> In addition, the success of interventions targeting reduction of exposure may be dependent on a multifaceted approach, and not just a single measure alone.<sup>117</sup> Recognizing the role of airway infection (including serious respiratory syncytial virus [RSV] and rhinovirus infections in early life) in the development of recurrent wheezing and asthma susceptibility in childhood, perhaps prophylaxis against them might help reduce asthma development. A lower incidence of recurrent wheezing (and even physician-documented episodes) over a 2-year follow-up period was found among preterm infants without chronic lung disease who had received palivizumab (a humanized monoclonal antibody against the RSV fusion protein) compared with preterm infants who had not received palivizumab, prior to enrollment.<sup>118</sup> There was also a significant difference in outcomes between palivizumab-treated and untreated children who were not hospitalized for RSV, suggesting that the effect of palivizumab was

not merely to prevent hospitalization but also to avert a lower respiratory tract illness from RSV. In addition, the protective effect of palivizumab appeared to be found in those children without a family history of asthma or atopy.<sup>119</sup>

A bacterial lysate, OM-85 BV, containing standardized lyophilized fractions per capsule from eight bacteria (*Haemophilus influenzae*, *Streptococcus pneumoniae*, *Klebsiella pneumoniae*, *Klebsiella ozaenae*, *Staphylococcus aureus*, *Streptococcus pyogenes*, *Streptococcus viridans* and *Neisseria*) is widely used in Europe to reduce acute respiratory tract infections. In a randomized, double-blind, placebo-controlled, parallel group study it has been found to be effective at reducing acute wheezing illnesses in children with a history of recurrent wheezing by 38% compared with placebo.<sup>120</sup> It remains to be evaluated in larger clinical trials if this can be an effective primary intervention modality that will prevent the development of asthma. Immunomodulators, including this immunostimulant, along with probiotics, prebiotics, anti-IgE and specific immunotherapy, are proposed as potential primary prevention interventions by a National Heart, Lung, and Blood Institute workshop committee.<sup>121</sup>

There has been a recent trend toward intervening early in the course of the disease with the hope of altering the natural history of asthma, and clinical trials of what can be considered secondary prevention measures have provided important observations. There have been studies that sought to determine if treatment with an ICS soon after the onset of early indicators of the disease would modify the course of asthma.<sup>19,47,63,102</sup> The study designs varied with respect to the eligibility criteria, age at entry, frequency of past wheezing episodes and manner and duration of treatment (e.g. maintenance vs intermittent or as needed intervention).

The NHLBI Childhood Asthma Research and Education (CARE) network-sponsored Prevention of Early Asthma in Kids (PEAK) study enrolled approximately 300 2- to 3-year-old children with more than three episodes of wheezing and a positive mAPI to receive either fluticasone propionate 88  $\mu\text{g}$  via pMDI or matching placebo twice daily for 2 years.<sup>19</sup> During the third year observation period of interest, no difference in either the proportion of children with active wheezing or lung function measured using forced oscillometry between the two treatment groups was found. However, during the first two years while on treatment, symptom control was better and asthma exacerbations fewer for the active treatment group compared to placebo. A reduction in growth velocity during the first 8 months ( $6.6 \pm 1.0$  vs  $7.3 \pm 1.0$  cm/yr between 1 and 8 months,  $P = .005$ ) and a smaller mean increase in height between 4 and 12 months ( $4.5 \pm 1.1$  vs  $4.9 \pm 1.1$  cm,  $P = .001$ ) were observed in the ICS group. However, during the second year of treatment, the growth velocity in the ICS group was greater than that in the placebo group ( $7.0 \pm 0.8$  vs  $6.4 \pm 0.9$  cm/yr,  $P = .001$ ). Children in the ICS group had an average height percentile of  $51.5 \pm 29.2$  compared to  $56.4 \pm 27.3$  in the placebo group at the end of treatment ( $P < .001$ ) and  $54.4 \pm 27.9$  compared to  $56.4 \pm 26.9$  at the end of observation ( $P = .03$ ).

Another study (IFWIN; Inhaled Fluticasone propionate in Wheezy Infants) evaluated whether ICS therapy for infants with a history of wheezing could prevent active asthma and prevent loss of lung function in later childhood.<sup>63</sup> A total of 200 children (mean age at entry 1.2 years) from a birth study cohort with two documented episodes of wheeze or one prolonged episode, more than 1 month duration, and a parental history of atopy

were randomized to receive fluticasone propionate 100 µg or matching placebo twice daily. At age 5 years, no difference between the ICS and placebo groups in the proportion of children with current wheeze, physician-diagnosed asthma and use of supplemental open-label ICS (fluticasone 100 µg twice daily) was found. Furthermore, the number of exacerbations, lung function (using sRaw through plethysmography with dynamic lung volumes and expiratory flow) and bronchial hyperreactivity (using eucapnic voluntary hyperventilation) were also not different between the groups. Children who were on ICS, particularly after 6 to 12 months, had transient reduction in growth velocity; and those who received both masked and open-label ICS had a slower rate of growth, compared to either the 'masked treatment only' or 'open-label treatment only' groups.

While these two studies demonstrate that long-term treatment with ICS does not modify the course of asthma, they also raise the potential for systemic effects of this intervention which can limit its use for this purpose. Using ICS only for an acute illness and evaluating its long-term impact is attractive not only because it is less burdensome but also it may decrease the risk of growth retardation.

One study, the Prevention of Asthma in Childhood (PAC), sought to determine whether early intervention using intermittent administration of an ICS, when initiated at the first episode of wheezing and during subsequent episodes, could alter the development of asthma.<sup>47</sup> Of 411 infants born to mothers with asthma enrolled at one month of age, approximately 300 children received at least one 14-day course of budesonide 400 µg/day or matching placebo administered via pMDI and holding chamber (mean age at the first course of study medication was 10.7 months). For every acute illness, children were to start either treatment after 3 days of wheezing. Upon completion of this 3-year study, a similar percentage of symptom-free days between treatment groups (83% vs 82% for the budesonide and placebo groups, respectively) was found. In addition, 24% and 21% of children in the budesonide and placebo groups, respectively, had persistent wheezing. The mean duration of each acute wheezing episode was not reduced by budesonide therapy. Lung function using pre- and post-bronchodilator sRaw at age 3 years was comparable between the two treatment groups. Lastly, there was no difference in height between the groups. Thus, intermittent ICS did not alter the natural history of asthma in infants at risk for asthma nor did it change the duration of the acute wheezing episodes.

The NHLBI CARE Acute Intervention Management Strategies (AIMS) study<sup>102</sup> randomized 238 children aged 12 to 59 months who had at least two episodes of moderate-to-severe wheezing requiring either an urgent care visit and/or systemic steroid course in the context of a respiratory tract illness within the past year. Participants were randomized to receive one of the following for 7 days at the onset of symptoms: budesonide inhalation suspension (1.0 mg twice daily) or montelukast group (4 mg once daily) or conventional rescue bronchodilator therapy. The primary outcome was the proportion of episode-free days (i.e. days free from cough, wheeze, trouble breathing, asthma-associated interference with daily activities or awakening from sleep, healthcare utilization due to wheezing, and use of asthma-related non-study medications) over the entire study period. Compared to conventional rescue bronchodilator therapy, neither budesonide nor montelukast initiated at early signs of illness increased the proportion of episode-free days over a 1-year period. In addition, no differential effect on oral

corticosteroid rescue, asthma healthcare utilization or quality of life was found. Nevertheless, both active study treatments demonstrated modest reductions in symptom severity score (such as wheezing, trouble breathing or activity limitation) relative to conventional therapy, particularly among children with positive API or prior oral corticosteroid use.

These studies provide important information regarding ICS therapy in young children with recurrent wheezing episodes although the overall results regarding prevention of progression to persistent asthma are not convincing. ICS can be indicated to improve asthma control but should not be expected to prevent the development of asthma or persistent wheezing, even for high-risk subjects.

## Conclusion

Chronic cough and recurrent wheezing, typical manifestations of asthma, are quite common in young children, yet these symptoms render different long-term outcomes and, acutely, varying severity. For those with a more persistent pattern, controller therapy is indicated. A significant subset have a severe, intermittent course, and for these patients daily controller therapy may still be beneficial. However, recent studies have suggested the efficacy of 'as needed' high-dose inhaled corticosteroid started at the onset of a respiratory illness, particularly in very young children who have atopic risk factors. The development of persistent asthma and requirement for long-term controller therapy in a very young child can be predicted to a limited degree. Currently no clinically available objective and reliable measure of lung function, bronchial hyperreactivity or airway inflammation exists that is applicable to this age group, hence monitoring the effects of interventions or treatment on prevention of asthma inception, modulation of underlying inflammation, perhaps airway remodeling, prevention of deterioration in lung function over time and induction of physiologic or immunologic remission is not feasible. The need to evaluate objectively the efficiency and safety of the various delivery devices and HFA formulation available for inhaled therapies to infants and young children remains. Only a few medications have been approved for use in this population, and studies have demonstrated effects on asthma control using short-term parameters. Studies on prevention of asthma development are warranted, especially in those who are deemed susceptible. Yet these are the ultimate goals that may motivate patients and families, if indeed interventions can really alter the development and the natural history of their disease. These studies often require large sample size and monitoring over longer periods of time which require enormous resources and the use of practical, objective measures of disease activity which are still lacking.

## Helpful Websites

The National Heart, Lung, and Blood Institute; website (<http://www.nhlbi.nih.gov/guidelines/asthma/asthgdl.htm>)

The Global Initiative for Asthma; website (<http://www.ginasthma.org/documents/4>)

The complete reference list can be found on the companion Expert Consult website at <http://www.expertconsult.inkling.com>.

## KEY REFERENCES

6. National Asthma Education and Prevention Program. Expert Panel Report 3 (EPR 3): guidelines for the diagnosis and management of asthma – summary report 2007. *J Allergy Clin Immunol* 2007;120(Suppl.):S94–138.
7. GINA. From the global strategy for asthma management and prevention, Global Initiative for Asthma (GINA). Available from: <http://www.ginasthma.org>; 2014.
14. Castro-Rodriguez JA, Holberg CJ, Wright AL, Martinez FD. A clinical index to define risk of asthma in young children with recurrent wheezing. *Am J Respir Crit Care Med* 2000;162:1403–6.
19. Guilbert T, Morgan W, Zeiger R, Mauger D, Boehmer S, Szeffler S, et al. Long-term inhaled corticosteroids in preschool children at risk for asthma. *N Engl J Med* 2006;354:1985–97.
42. Saglani S, Payne D, Zhu J, Wang Z, Nicholson AG, Bush A, et al. Early detection of airway wall remodeling and eosinophilic inflammation in preschool wheezers. *Am J Respir Crit Care Med* 2007;176:858–64.
43. Saglani S, Malmstrom K, Pelkonen A, Malmberg LP, Lindahl H, Kajosaari M, et al. Airflow remodeling and inflammation in symptomatic infants with reversible airflow obstruction. *Am J Respir Crit Care Med* 2005;171:722–7.
46. Ducharme FM, Lemire C, Noya FJ, Davis GM, Alos N, Leblond H, et al. Preemptive use of high-dose fluticasone for virus-induced wheezing in young children. *N Engl J Med* 2009;360:339–53.
47. Bisgaard H, Hermansen M, Loland L, Halkjaer LB, Buchvald F. Intermittent inhaled corticosteroids in infants with episodic wheezing. *N Engl J Med* 2006;354:1998–2005.
48. Zeiger RS, Mauger D, Bacharier LB, Guilbert TW, Martinez FD, Lemanske RF Jr, et al. Daily or intermittent budesonide in preschool children with recurrent wheezing. *N Engl J Med* 2011;365:1990–2001.
51. Murphy KR, Zeiger RS, Kosinski M, Chipps B, Mellon M, Schatz M, et al. Test for respiratory and asthma control in kids (TRACK): a caregiver-completed questionnaire for preschool-aged children. *J Allergy Clin Immunol* 2009;123:833–9.

## REFERENCES

- Akinbami LJ, Moorman JE, Garbe PL, Sondik EJ. Status of childhood asthma in the United States, 1980–2007. *Pediatrics* 2009;123:S131–45.
- Moorman JE, Akinbami LJ, Bailey CM, Zahran HS, King ME, Johnson CA, et al. National surveillance of asthma: United States, 2001–2010. *Vital Health Stat* 2012;3:1–67.
- Mitchell EA, Bland JM, Thompson JMD. Risk factors for readmission to hospital for asthma in childhood. *Thorax* 1994;49:33–6.
- Paret G, Kornecki A, Szeinberg A, Vardi A, Barzilai A, Augarten A, et al. Severe acute asthma in a community hospital pediatric intensive care unit: a ten years' experience. *Ann Allergy Asthma Immunol* 1998;80:339–44.
- Martin AJ, Landau LI, Phelan PD. Lung function in young adults who had asthma in childhood. *Am Rev Respir Dis* 1980;122:609–16.
- National Asthma Education and Prevention Program. Expert Panel Report 3 (EPR 3): guidelines for the diagnosis and management of asthma – summary report 2007. *J Allergy Clin Immunol* 2007;120(Suppl.):S94–138.
- GINA. From the global strategy for asthma management and prevention, Global Initiative for Asthma (GINA). Available from: <http://www.ginasthma.org>; 2014.
- Shaheen SO, Newson RB, Henderson AJ, Headley JE, Stratton FD, Jones RW, et al. Prenatal paracetamol exposure and risk of asthma and elevated immunoglobulin E in childhood. *Clin Exp Allergy* 2005;35:18–25.
- Beasley R, Clayton T, Crane J, von Mutius E, Lai CK, Montefort S, et al. Association between paracetamol use in infancy and childhood, and risk of asthma, rhinoconjunctivitis, and eczema in children aged 6–7 years: analysis from Phase Three of the ISAAC programme. *Lancet* 2008;372:1039–48.
- Beasley RW, Clayton TO, Crane J, Lai CK, Montefort SR, Mutius EV, et al. Acetaminophen use and risk of asthma, rhinoconjunctivitis, and eczema in adolescents: International Study of Asthma and Allergies in Childhood Phase Three. *Am J Respir Crit Care Med* 2011;183:171–8.
- Barr RG, Wentowski CC, Curhan GC, Somers SC, Stampfer MJ, Schwartz J, et al. Prospective study of acetaminophen use and newly diagnosed asthma among women. *Am J Respir Crit Care Med* 2004;169:836–41.
- Lowe LA, Simpson A, Woodcock A, Morris J, Murray CS, Custovic A. Wheeze phenotypes and lung function in preschool children. *Am J Respir Crit Care Med* 2005;171:231–7.
- Martinez FD, Wright AL, Taussig LM, Holberg CJ, Halonen M, Morgan WJ. Asthma and wheezing in the first six years of life. *N Engl J Med* 1995;332:133–8.
- Castro-Rodriguez JA, Holberg CJ, Wright AL, Martinez FD. A clinical index to define risk of asthma in young children with recurrent wheezing. *Am J Respir Crit Care Med* 2000;162:1403–6.
- Guilbert TW, Morgan WJ, Zeiger RS, Bacharier LB, Boehmer SJ, Krawiec M, et al. Atopic characteristics of children with recurrent wheezing at high risk for the development of childhood asthma. *J Allergy Clin Immunol* 2004;114:1282–7.
- Kulig M, Bergmann R, Tacke U, Wahn U, Guggenmoos-Holzmann I. Long-lasting sensitization to food during the first two years precedes allergic airway disease. The MAS Study Group, Germany. *Pediatr Allergy Immunol* 1998;9:61–7.
- Lau S, Illi S, Sommerfeld C, Niggemann B, Bergmann R, von Mutius E, et al. Early exposure to house-dust mite and cat allergens and development of childhood asthma: a cohort study. Multicentre Allergy Study Group. *Lancet* 2000;356:1392–7.
- Zeiger RS, Heller S. The development and prediction of atopy in high-risk children: follow-up at age seven years in a prospective randomized study of combined maternal and infant food allergen avoidance. *J Allergy Clin Immunol* 1995;95:1179–90.
- Guilbert T, Morgan W, Zeiger R, Mauger D, Boehmer S, Szefer S, et al. Long-term inhaled corticosteroids in preschool children at risk for asthma. *N Engl J Med* 2006;354:1985–97.
- Brand PL, Baraldi E, Bisgaard H, Boner A, Castro-Rodriguez J, Custovic A, et al. Definition, assessment and treatment of wheezing disorders in preschool children: an evidence-based approach. *Eur Respir J* 2008;32:1096–110.
- Brand PL, Caudri D, Eber E, Gaillard EA, Garcia-Marcos L, Hedlin G, et al. Classification and pharmacological treatment of preschool wheezing: changes since 2008. *Eur Respir J* 2014;43:1172–7.
- Young S, Le Souef PN, Geelhoed GC, Stick SM, Turner KJ, Landau LI. The influence of a family history of asthma and parental smoking on airway responsiveness in early infancy. *N Engl J Med* 1991;324:1168–73.
- Ibero M, Ridaio M, Artigas R, Martin B, Tresserras R. Cisapride treatment changes the evolution of infant asthma with gastroesophageal reflux. *J Investig Allergol Clin Immunol* 1998;8:176–9.
- Werk LN, Steinbach S, Adams WG, Bauchner H. Beliefs about diagnosing asthma in young children. *Pediatrics* 2000;105:585–90.
- Expert Panel Report II. Guidelines for the diagnosis and management of asthma. Bethesda, MD: National Heart, Lung, and Blood Institute/National Institutes of Health; 1997.
- Hellinckx J, Boeck K, Bande-Knops J, van der Poel M, Demedts M. Bronchodilator response in 3–6.5 years old healthy and stable asthmatic children. *Eur Respir J* 1998;12:438–43.
- Marotta A, Klinnert MD, Price MR, Larsen GL, Liu AH. Impulse oscillometry provides an effective measure of lung dysfunction in 4-year-old children at risk for persistent asthma. *J Allergy Clin Immunol* 2003;112:317–22.
- Delacourt C, Lorino H, Fuhrman C, Herve-Guillot M, Reinert P, Harf A, et al. Comparison of the forced oscillation technique and the interrupter technique for assessing airway obstruction and its reversibility in children. *Am J Respir Crit Care Med* 2001;164:965–72.
- Nielsen KG, Bisgaard H. Discriminative capacity of bronchodilator response measured with three different lung function techniques in asthmatic and healthy children aged 2 to 5 years. *Am J Respir Crit Care Med* 2001;164:554–9.
- Nielsen KG, Bisgaard H. Hyperventilation with cold versus dry air in 2- to 5-year-old children with asthma. *Am J Respir Crit Care Med* 2005;171:238–41.
- Lowe LA, Simpson A, Woodcock A, Morris J, Murray CS, Custovic A. Wheeze phenotypes and lung function in preschool children. *Am J Respir Crit Care Med* 2005;171:231–7.
- Artlich A, Busch T, Lewandowski K, Jonas S, Gortner L, Falke KJ. Childhood asthma: exhaled nitric oxide in relation to clinical symptoms. *Eur Respir J* 1999;13:1396–401.
- Piacentini GL, Bodini A, Costella S, Vicentini L, Mazzi P, Sperandio S, et al. Exhaled nitric oxide and sputum eosinophil markers of inflammation in asthmatic children. *Eur Respir J* 1999;13:1386–90.
- Baraldi E, Azzolin NM, Zanconato S, Dario C, Zacchello F. Corticosteroids decrease exhaled nitric oxide in children with acute asthma. *J Pediatr* 1997;131:381–5.
- Carra S, Gagliardi L, Zanconato S, Scollo M, Azzolin N, Zacchello F, et al. Budesonide but not nedocromil sodium reduces exhaled nitric oxide levels in asthmatic children. *Respir Med* 2001;95:734–9.
- Mattes J, Storm van's Gravesande K, Reining U, Alving K, Horst G, Henschen M, et al. NO in exhaled air is correlated with markers of eosinophilic airway inflammation in corticosteroid-dependent childhood asthma. *Eur Respir J* 1999;13:1391–5.
- Buchvald F, Bisgaard H. FeNO measured at fixed exhalation flow rate during controlled tidal breathing in children from the age of 2 yr. *Am J Respir Crit Care Med* 2001;163:699–704.
- Baraldi E, Dario C, Ongaro R, Scollo M, Azzolin NM, Panza N, et al. Exhaled nitric oxide concentrations during treatment of wheezing exacerbation in infants and young children. *Am J Respir Crit Care Med* 1999;159:1284–8.
- van der Heijden HH, Brouwer ML, Hoekstra F, van der Pol P, Merkus PJ. Reference values of exhaled nitric oxide in healthy children 1–5 years using off-line tidal breathing. *Pediatr Pulmonol* 2014;49:291–5.
- Singer F, Luchsinger I, Inci D, Knauer N, Latzin P, Wildhaber JH, et al. Exhaled nitric oxide in symptomatic children at preschool age predicts later asthma. *Allergy* 2013;68:531–8.
- Carlsen KCL, Halvorsen R, Ahlstedt S, Carlsen KH. Eosinophil cationic protein and tidal flow volume loops in children 0–2 years of age. *Eur Respir J* 1995;8:1148–54.
- Saglani S, Payne D, Zhu J, Wang Z, Nicholson AG, Bush A, et al. Early detection of airway wall remodeling and eosinophilic inflammation in preschool wheezers. *Am J Respir Crit Care Med* 2007;176:858–64.
- Saglani S, Malmstrom K, Pelkonen A, Malmberg LP, Lindahl H, Kajosaari M, et al. Airflow remodeling and inflammation in symptomatic infants with reversible airflow obstruction. *Am J Respir Crit Care Med* 2005;171:722–7.
- Le Bourgeois M, Goncalves M, Le Clainche L, Benoit MR, Fournet JC, Scheinmann P, et al. Bronchoalveolar cells in children <3 years old with severe recurrent wheezing. *Chest* 2002;122:791–7.
- Jenkins H, Cool C, Szefer S, Covar R, Brugman S, Gelfand EW, et al. Histopathology of severe childhood asthma: a case series. *Chest* 2003;124:32–41.
- Ducharme FM, Lemire C, Noya FJ, Davis GM, Alos N, Leblond H, et al. Preemptive use of high-dose fluticasone for virus-induced



- wheezing in young children. *N Engl J Med* 2009;360:339–53.
47. Bisgaard H, Hermansen M, Loland L, Halkjaer LB, Buchvald F. Intermittent inhaled corticosteroids in infants with episodic wheezing. *N Engl J Med* 2006;354:1998–2005.
  48. Zeiger RS, Mauger D, Bacharier LB, Guilbert TW, Martinez FD, Lemanske RF Jr, et al. Daily or intermittent budesonide in preschool children with recurrent wheezing. *N Engl J Med* 2011;365:1990–2001.
  49. Nathan RA, Sorkness CA, Kosinski M, Schatz M, Li JT, Marcus P, et al. Development of the asthma control test: a survey for assessing asthma control. *J Allergy Clin Immunol* 2004;113:59–65.
  50. Liu AH, Zeiger R, Sorkness C, Mahr T, Ostrom N, Burgess S, et al. Development and cross-sectional validation of the Childhood Asthma Control Test. *J Allergy Clin Immunol* 2007;119:817–25.
  51. Murphy KR, Zeiger RS, Kosinski M, Chipps B, Mellon M, Schatz M, et al. Test for respiratory and asthma control in kids (TRACK): a caregiver-completed questionnaire for preschool-aged children. *J Allergy Clin Immunol* 2009;123:833–9.
  52. DeBlic J, Delacourt C, LeBourgeois M, Mahut B, Ostinelli J, Caswell C, et al. Efficacy of nebulized budesonide in treatment of severe infantile asthma: a double blind study. *J Allergy Clin Immunol* 1996;98:14–20.
  53. Ilangovan P, Pedersen S, Godfrey S, Nikander K, Noviski N, Warner J. Treatment of severe steroid-dependent preschool asthma with nebulized budesonide suspension. *Arch Dis Child* 1993;68:356–9.
  54. Shapiro G, Mendelson L, Kraemer MJ, Cruz-Rivera M, Walton-Brown K, Smith JA. Efficacy and safety of budesonide inhalation suspension (Pulmicort Respules) in young children with inhaled steroid-dependent, persistent asthma. *J Allergy Clin Immunol* 1998;102:789–96.
  55. Kemp JP, Skoner DP, Szefer SJ, Walton-Bowen K, Cruz-Rivera M, Smith JA. Once-daily budesonide inhalation suspension for the treatment of persistent asthma in infants and young children. *Ann Allergy Asthma Immunol* 1999;83:231–9.
  56. Baker JW, Mellon M, Wald J, Welch M, Cruz-Rivera M, Walton-Bowen K. A multiple-dosing, placebo-controlled study of budesonide inhalation suspension given once or twice daily for treatment of persistent asthma in young children and infants. *Pediatrics* 1999;103:414–21.
  57. Agertoft L, Andersen A, Weibull E, Pedersen S. Systemic availability and pharmacokinetics of nebulized budesonide in preschool children. *Arch Dis Child* 1999;80:241–7.
  58. Roorda RJ, Mezei G, Bisgaard H, Maden C. Response of preschool children with asthma symptoms to fluticasone propionate. *J Allergy Clin Immunol* 2001;108:540–6.
  59. Sutherland ER, Busse WW. Designing clinical trials to address the needs of childhood and adult asthma: the National Heart, Lung, and Blood Institute's AsthmaNet. *J Allergy Clin Immunol* 2014;133:34–8.
  60. Panickar J, Lakanpaul M, Lambert PC, Kenia P, Stephenson T, Smyth A, et al. Oral prednisolone for preschool children with acute virus-induced wheezing. *N Engl J Med* 2009;360:329–38.
  61. Reid A, Murphy C, Steen HJ, McGowen V, Shields MD. Linear growth of very young asthmatic children treated with high-dose nebulized budesonide. *Acta Paediatr* 1996;85:421–4.
  62. Skoner DP, Szefer SJ, Welch M, Walton-Bowen K, Cruz-Rivera M, Smith JA. Longitudinal growth in infants and young children treated with budesonide inhalation suspension for persistent asthma. *J Allergy Clin Immunol* 2000;105:259–68.
  63. Murray C, Woodcock A, Langley S, Morris J, Custovic A, IFWIN study team for the IFWIN Study Team. Secondary prevention of asthma by the use of inhaled fluticasone propionate in wheezy infants (IFWIN). *Lancet* 2006;368:754–62.
  64. Guilbert TW, Mauger DT, Allen DB, Zeiger RS, Lemanske RF Jr, Szefer SJ, et al. Growth of preschool children at high risk for asthma 2 years after discontinuation of fluticasone. *J Allergy Clin Immunol* 2011;128:956–63.
  65. Ninan TK, Russell G. Asthma, inhaled corticosteroid treatment, and growth. *Arch Dis Child* 1992;67:703–5.
  66. Tasche MJ, Van Der Wouden JC, Uijen JH, Ponsioen BP, Bernsen RM, van Suijlekom-Smit LW, et al. Randomized placebo-controlled trial of inhaled sodium cromoglycate in 1–4 year old children with moderate asthma. *Lancet* 1997;350:1060–4.
  67. Bertelsen A, Andersen JB, Busch P, Daugbjerg P, Friis B, Hansen L, et al. Nebulized sodium cromoglycate in the treatment of wheezy bronchitis. *Allergy* 1986;41:266–70.
  68. Furfaro S, Spier S, Drblik SP, Turgeon JP, Robert M. Efficacy of cromoglycate in persistently wheezing infants. *Arch Dis Child* 1994;71:331–4.
  69. Hiller EJ, Milner AD, Lenney W. Nebulized sodium cromoglycate in young asthmatic children: double-blind trial. *Arch Dis Child* 1977;52:875–6.
  70. Glass J, Archer LNJ, Adams W, Simpson H. Nebulized cromoglycate, theophylline, and placebo in preschool asthmatic children. *Arch Dis Child* 1981;56:648–51.
  71. Cogswell JJ, Simpkins MJ. Nebulized sodium cromoglycate in recurrently wheezy preschool children. *Arch Dis Child* 1985;60:736–8.
  72. Tasche MJ, Uijen JH, Bernsen RM, de Jongste JC, van der Wouden JC. Inhaled disodium cromoglycate (DSCG) as maintenance therapy in children with asthma: a systematic review. *Thorax* 2000;55:913–20.
  73. Leflein JG, Szefer SJ, Murphy KR, Fitzpatrick S, Cruz-Rivera M, Miller CJ, et al. Nebulized budesonide inhalation suspension compared with cromolyn sodium nebulizer solution for asthma in young children: results of a randomized outcomes trial. *Pediatrics* 2002;109:866–72.
  74. Simons FE. A comparison of beclomethasone, salmeterol, and placebo in children with asthma. Canadian Beclomethasone Dipropionate-Salmeterol Xinafoate Study Group. *N Engl J Med* 1997;337:1659–65.
  75. Verberne AA, Frost C, Roorda RJ, van der Laag H, Kerrebijn KF. One year treatment with salmeterol compared with beclomethasone in children with asthma. The Dutch Paediatric Asthma Study Group. *Am J Respir Crit Care Med* 1997;156:688–95.
  76. Chung KF. Leukotriene receptor antagonists and biosynthesis inhibitors: potential breakthrough in asthma therapy. *Eur Respir J* 1995;8:1203–13.
  77. Israel E, Rubin P, Kemp JP, Grossman J, Pierson W, Siegel SC, et al. The effect of inhibition of 5-lipoxygenase by zileuton in mild-to-moderate asthma. *Ann Intern Med* 1993;119:1059–66.
  78. Liu MC, Dube LM, Lancaster J. Acute and chronic effects of a 5-lipoxygenase inhibitor in asthma: a 6-month randomized multicenter trial. Zileuton Study Group. *J Allergy Clin Immunol* 1996;98:859–71.
  79. Spector SL, Smith LJ, Glass M. Effects of 6 weeks of therapy with oral doses of ICI 204,219, a leukotriene D4 receptor antagonist, in subjects with bronchial asthma. ACCOLATE Asthma Trialists Group. *Am J Respir Crit Care Med* 1994;150:618–23.
  80. Knorr B, Franchi LM, Bisgaard H, Vermeulen JH, LeSouef P, Santanello N, et al. Montelukast, a leukotriene receptor antagonist, for the treatment of persistent asthma in children aged 2 to 5 years. *Pediatrics* 2001;108:E48.
  81. Bisgaard H, Zielen S, Garcia Garcia L, Johnston SL, Gilles L, Menten J, et al. Montelukast reduces asthma exacerbations in 2 to 5 year-old children with intermittent asthma. *Am J Respir Crit Care Med* 2005;171:315–22.
  82. Robertson C, Price D, Henry R, Mellis C, Glasgow N, Fitzgerald D, et al. Short-course montelukast for intermittent asthma in children. *Am J Respir Crit Care Med* 2007;175:323–9.
  83. Fitzpatrick MF, Mackay T, Driver H, Douglas NJ. Salmeterol in nocturnal asthma: a double-blind, placebo controlled trial of a long-acting inhaled beta 2 agonist. *Br Med J* 1990;301:1365–8.
  84. Green CP, Price JF. Prevention of exercise-induced asthma by inhaled salmeterol xinafoate. *Arch Dis Child* 1992;67:1014–17.
  85. Primhak RA, Smith CM, Yong SC, Wach R, Kurian M, Brown R, et al. The bronchoprotective effect of inhaled salmeterol in preschool children: a dose-ranging study. *Eur Respir J* 1999;13:78–81.
  86. Newhouse MT. Pulmonary drug targeting with aerosols: principles and clinical applications in adults and children. *Am J Asthma Allergy Pediatr* 1993;7:23–35.
  87. Dolovich MB, Ahrens RC, Hess DR, Anderson P, Dhand R, Rau JL, et al. Device selection and outcomes of aerosol therapy: evidence-based guidelines. *Chest* 2005;127:335–71.
  88. Parkin PC, Saunders NR, Diamond SA, Winders PM, Macarthur C. Randomized trial spacer vs nebulizer for acute asthma. *Arch Dis Child* 1995;72:239–40.
  89. Closa RM, Ceballos JM, Gomez-Papi A, Galiana AS, Gutierrez C, Marti-Henneber C. Efficacy of bronchodilators administered by nebulizers versus spacer devices in infants with acute wheezing. *Pediatr Pulmonol* 1998;26:344–8.
  90. Tal A, Golan H, Grauer N, Aviram M, Albin D, Quastel MR. Deposition pattern of radiolabeled salbutamol inhaled from a metered-dose inhaler by means of a spacer with mask in young children with airway obstruction. *J Pediatr* 1996;128:479–84.
  91. Wildhaber JH, Dore ND, Wilson JM, Devadason SG, LeSouef PN. Inhalation therapy in asthma: nebulizer or pressurized metered-dose inhaler with holding chamber? *In vivo*

- comparison of lung deposition in children. *J Pediatr* 1999;135:28–33.
92. Gibson NA, Ferguson AE, Aitchison TC, Paton JY. Compliance with inhaled asthma medication in preschool children. *Thorax* 1995;50:1274–9.
  93. Ferguson AE, Gibson NA, Aitchison TC, Paton JY. Measured bronchodilator use in preschool children with asthma. *Br Med J* 1995;310:1161–4.
  94. Lim SH, Goh DYT, Tan AYS, Lee BW. Parents' perceptions towards their child's use of inhaled medications for asthma therapy. *J Paediatr Child Health* 1996;32:306–9.
  95. Mesters I, Meertens R, Kok G, Parcel GS. Effectiveness of a multidisciplinary education protocol in children with asthma (0–4 years) in primary health care. *J Asthma* 1994;31:347–59.
  96. Wilson SR, Latini D, Starr NJ, Fish L, Loes LM, Page A, et al. Education of parents of infants and very young children with asthma: a developmental evaluation of the Wee Wheezers program. *J Asthma* 1996;33:239–54.
  97. Gore C, Custovic A. Primary and secondary prevention of allergic airway disease. *Paediatr Respir Rev* 2003;4:213–24.
  98. Arshad SH, Bateman B, Matthews SM. Primary prevention of asthma and atopy during childhood by allergen avoidance in infancy: a randomised controlled study. *Thorax* 2003;58:489–93.
  99. Arshad SH, Bateman B, Sadeghnejad A, Gant C, Matthews SM. Prevention of allergic disease during childhood by allergen avoidance: the Isle of Wight prevention study. *J Allergy Clin Immunol* 2007;119:307–13.
  100. Kramarz P, Destefano F, Gargiullo PM, Chen RT, Lieu TA, Davis RL, et al. Does influenza vaccination prevent asthma exacerbations in children? *J Pediatr* 2001;138:306–10.
  101. Vuillermin P, South M, Robertson C. Parent-initiated oral corticosteroid therapy for intermittent wheezing illnesses in children. *Cochrane Database Syst Rev* 2006;3:CD005311.
  102. Bacharier LB, Phillips BR, Zeiger RS, Szefer SJ, Martinez FD, Lemanske RF, et al. Episodic use of an inhaled corticosteroid or leukotriene receptor antagonist in preschool children with moderate-to-severe intermittent wheezing. *J Allergy Clin Immunol* 2008;122:1127–35.
  103. Gouin S, Robidas J, Gravel J, Guimont C, Chalut D, Amre D. Prospective evaluation of two clinical scores for acute asthma in children 18 months to 7 years of age. *Acad Emerg Med* 2010;17:598–603.
  104. Powell C, Kolamunnage-Dona R, Lowe J, Boland A, Petrou S, Doull I, et al. Magnesium sulphate in acute severe asthma in children (MAGNETIC): a randomised, placebo-controlled trial. *Lancet Respir Med* 2013;1:301–8.
  105. Bustos GJ, Bustos D, Bustos GJ, Romero O. Prevention of asthma with ketotifen in pre-asthmatic children: a three-year follow-up study. *Clin Exp Allergy* 1995;25:568–73.
  106. Warner JO, Early Treatment of the Atopic Child Group. A double-blinded, randomized, placebo-controlled trial of cetirizine in preventing the onset of asthma in children with atopic dermatitis: 18 months' treatment and 18 months' posttreatment follow up. *J Allergy Clin Immunol* 2001;108:929–37.
  107. Peat JK, Tovey E, Toelle BG, Haby MM, Gray EJ, Mahmic A, et al. House dust mite allergens. A major risk factor for childhood asthma in Australia. *Am J Respir Crit Care Med* 1996;153:141–6.
  108. Platts-Mills TA, Rakes G, Heymann PW. The relevance of allergen exposure to the development of asthma in childhood. *J Allergy Clin Immunol* 2000;105:S503–8.
  109. Arshad SH, Bateman B, Sadeghnejad A, Gant C, Matthews SM. Prevention of allergic disease during childhood by allergen avoidance: the Isle of Wight prevention study. *J Allergy Clin Immunol* 2007;119:307–13.
  110. Chan-Yeung M, Ferguson A, Watson W, Dimich-Ward H, Rousseau R, Lilley M, et al. The Canadian Childhood Asthma Primary Prevention Study: outcomes at 7 years of age. *J Allergy Clin Immunol* 2005;116:49–55.
  111. Marks GB, Mihrshahi S, Kemp AS, Tovey ER, Webb K, Almqvist C, et al. Prevention of asthma during the first 5 years of life: a randomized controlled trial. *J Allergy Clin Immunol* 2006;118:53–61.
  112. Toelle BG, Ng KK, Crisafulli D, Belousova EG, Almqvist C, Webb K, et al. Eight-year outcomes of the Childhood Asthma Prevention Study. *J Allergy Clin Immunol* 2010;126:388–9 (e1–3).
  113. Corver K, Kerkhof M, Brussee JE, Brunekreef B, van Strien RT, Vos AP, et al. House dust mite allergen reduction and allergy at 4 yr: follow up of the PIAMA-study. *Pediatr Allergy Immunol* 2006;17:329–36.
  114. Horak F Jr, Matthews S, Ihorst G, Arshad SH, Frischer T, Kuehr J, et al. Effect of mite-impermeable mattress encasings and an educational package on the development of allergies in a multinational randomized, controlled birth-cohort study – 24 months results of the Study of Prevention of Allergy in Children in Europe. *Clin Exp Allergy* 2004;34:1220–5.
  115. Woodcock A, Lowe LA, Murray CS, Simpson BM, Pipis SD, Kissen P, et al. Early life environmental control: effect on symptoms, sensitization, and lung function at age 3 years. *Am J Respir Crit Care Med* 2004;170:433–9.
  116. Maas T, Kaper J, Sheikh A, Knotnerus JA, Wesseling G, Dompeling E, et al. Mono and multifaceted inhalant and/or food allergen reduction interventions for preventing asthma in children at high risk of developing asthma. *Cochrane Database Syst Rev* 2009;3:CD006480.
  117. Martinez FD. New insights the natural history of asthma: primary prevention on the horizon. *J Allergy Clin Immunol* 2011;128:939–45.
  118. Simoes EA, Groothuis JR, Carbonell-Estrany X, Rieger CH, Mitchell I, Fredrick LM, et al. Palivizumab Long-Term Respiratory Outcomes Study Group. Palivizumab prophylaxis, respiratory syncytial virus, and subsequent recurrent wheezing. *J Pediatr* 2007;151:34–42.
  119. Simões EA, Carbonell-Estrany X, Rieger CH, Mitchell I, Fredrick L, Groothuis JR, et al. The effect of respiratory syncytial virus on subsequent recurrent wheezing in atopic and non-atopic children. *J Allergy Clin Immunol* 2010;126:256–62.
  120. Razi CH, Harmancı K, Abacı A, Özdemir O, Hizli S, Renda R, et al. The immunostimulant OM-85 BV prevents wheezing attacks in preschool children. *J Allergy Clin Immunol* 2010;126:763–9.
  121. Jackson DJ, Hartert TV, Martinez FD, Weiss ST, Fahy JV. Asthma: NHLBI Workshop on the primary prevention of chronic lung diseases. *Ann Am Thorac Soc* 2014;11(S3):S139–45.

# Inner City Asthma: Strategies to Reduce Mortality and Morbidity

MEYER KATTAN

## KEY POINTS

- Racial and ethnic minorities and children with low socioeconomic status living in urban communities have a disproportionate burden of asthma morbidity, mortality and healthcare use.
- Successful interventions targeting inner city children with asthma must be multifactorial and take into account access to care, social, environmental and behavioral factors.
- Community linkages, epidemiologic evaluation, self-management, decision support and improved patient-provider communication are essential ingredients of asthma management programs.
- It is important to determine individual risks and tailor asthma interventions in the context of the physical and social environments.
- Translation of successful evidence-based interventions into practice presents a challenge that requires evaluation and feedback from those implementing these interventions at the community level.

Wide variations exist in the prevalence of childhood asthma worldwide, ranging from less than 1% to as high as 37%.<sup>1</sup> The National Health Interview Survey in 2012 reported that 9.3% of children under age 18 in the USA have asthma and 14% have been diagnosed with asthma at some time in their lives. Small area analyses have demonstrated asthma period prevalence rate in poor urban communities in the USA to be twice the national prevalence rate.<sup>2</sup> Children in poor families are more likely to have current asthma than children in families that are not poor (13% vs 8%). There is variation in prevalence among ethnic groups. Puerto Rican children living in the Northeast USA reported some of the highest prevalence rates. Disparities in morbidity in addition to prevalence are evident. Hospitalization rates and emergency department (ED) visits are highest in poor urban areas.<sup>3,4</sup> Reviews of asthma disparities find that African American and Hispanic children who live in low socioeconomic urban environments experience higher morbidity and mortality than white children.<sup>5,6</sup> In the UK, blacks and south Asians are at significantly increased risk of admission for asthma.<sup>7</sup>

Racial and ethnic minorities that are socioeconomically disadvantaged and disproportionately affected by asthma live predominantly in densely populated urban areas. These so-called 'inner cities' are not uniform in many of their characteristics. The differences include housing stock, climate, environmental exposures, race and ethnicity. As a result of the documented disparities in asthma morbidity, the inner cities have been the

focus of studies to determine the characteristics of these areas that contribute to high prevalence and morbidity and to develop interventions.

The relationship of race/ethnicity, environment and socioeconomic status (SES) to asthma morbidity is complex. The hospital readmission rate for asthma is twice as high in African Americans compared to whites. In an attempt to characterize the racial disparities, one study found that traditional SES measures coupled with financial and social hardship explained 50% of the readmission rate.<sup>8</sup> Behavioral factors and patterns of care also determine asthma outcome. Jones et al demonstrated that minority children with wheeze were nearly twice as likely as white children to have used urgent care for asthma, after controlling for disease severity, access to care and environmental factors.<sup>9</sup> Puerto Rican children had more clinic visits for asthma but spent fewer days in the hospital for asthma than African American children.<sup>10</sup> Health beliefs may differ among various cultures. Ethnic minorities with low incomes might regard asthma as less serious than other pressing problems of life.<sup>11</sup> Low parental expectations and competing family priorities are associated with poor asthma control. In a multivariate analysis that included these factors in the analytic model, the association between race/ethnicity and poor asthma control was not significant.<sup>12</sup> In summary, a variety of interrelated factors contribute to morbidity and multifaceted tailored interventions are more likely to succeed.

## Challenges to Asthma Management

Despite the existence of effective disease control strategies and medications, asthma remains a major public health problem. Morbidity, direct and indirect healthcare costs and mortality continue to impose a high burden. Individual asthma care is only one component of effective asthma control. Compared with social, environmental and behavioral factors, medical care has only a relatively small influence on health for populations.<sup>13</sup> The role of these factors was evident in the initial studies of the National Inner City Asthma Study (NCICAS). Poor housing stock, crowded living conditions and poor access to appropriate health care despite the availability of insurance are barriers. Exposure and sensitization to allergens such as cockroach and mouse, as well as exposure to indoor pollutants such as environmental tobacco smoke and nitrogen dioxide are high.<sup>14</sup> It is important to note that these risk factors vary from one child to the next.

Interventions aimed at primary prevention of asthma in inner city children are lacking. Longitudinal birth cohort studies are underway that may drive novel interventions. These studies will increase our understanding of the interaction of prenatal factors, viral infections, environmental tobacco smoke,

microbiome, epigenetics and stress in the development of asthma. There are no effective public health strategies or treatment regimes that reduce the risk of developing asthma or influence its natural history.

Evidence indicates that establishment of a successful asthma management program entails a logical progression through specific developmental stages, starting with political/stakeholder endorsement and commitment, followed by epidemiologic evaluation, evaluation of disease burden, evaluation of access to care and best therapy, and finally optimization and maintenance therapy for individual patients.<sup>15</sup> Applying a model embodying these concepts in an inner city setting for patients with chronically poorly controlled asthma resulted in sustained improvement in asthma control in adolescent patients. The interventions implemented included delivery system redesign to provide standardized and evidence-based care, productive interactions between informed patients and prepared clinicians, self-management support, community linkages, clinical information systems and decision support.<sup>16</sup>

### Factors Contributing to Morbidity in Inner Cities (Table 33-1)

#### ASTHMA KNOWLEDGE AND PATTERNS OF CARE

Insufficient caregiver and child asthma knowledge contributes to asthma morbidity but inability to apply the knowledge and change behavior also plays a role. The NCICAS found that although caregivers of inner city children had reasonably good asthma knowledge, they had difficulty giving responses that could be helpful in asthma management when they were given hypothetical vignettes.<sup>17</sup> The caregiver's expectations regarding his or her ability to manage the child's asthma are predictive of the child's functional status, suggesting that attitudes play a role in determining the child's asthma outcome.<sup>18</sup> Negative beliefs about medications and low expectations about the benefit of the medications are predisposing factors associated with poor clinical outcome. Low parental involvement and delays in recognizing symptoms and initiating therapy are also associated with poor outcomes. Patients and caregivers tolerate poor symptom control and possess inadequate knowledge of correct drug usage.<sup>19</sup> Language barriers between provider and patient or caregiver contribute to underreporting of symptoms and suboptimal communication.<sup>20</sup> The interactions are complex and interventions must identify breakdowns in the pathways to optimize outcomes (Figure 33-1).

Children with lower SES have fewer doctor visits despite more ED visits and hospitalizations.<sup>3,21</sup> Most children have a usual source of primary care but when symptomatic with asthma have difficulty finding care outside the ED.<sup>14</sup> Use of the

ED leads to more fragmented care. Children use reliever medication more frequently than antiinflammatory medications.<sup>22,23</sup> In a managed care setting in a low SES group, African Americans fill fewer prescriptions than Caucasians.

#### ADHERENCE

Overall estimates for adherence to medications are about 50%<sup>24,25</sup> (Box 33-1). In adolescents, asthma prevention and management behaviors were suboptimal with only 36% of those prescribed medication for persistent asthma reporting taking medications daily.<sup>26</sup> Adherence to an asthma management program involves use of controller medication, appointment keeping and applying an emergency plan of action. Barriers to adherence may exist in any of these areas, leading to ineffective control of asthma.<sup>27</sup> Concern about side-effects and negative caregiver beliefs regarding efficacy of medications are more likely in nonadherent compared to adherent children.<sup>27,28</sup> Studies show that caregivers of children with asthma have cultural beliefs about asthma medications that provide the rationale for limiting or discontinuing the use of medications.<sup>29-31</sup> Even when a controller medication was prescribed by a physician, more than one third of caregivers did not report it, and this discordance was related to caregivers' beliefs about treatment.<sup>32</sup> Smith et al reported that suboptimal asthma control and controller medication underuse were highly associated with potentially modifiable risk factors, especially low parental expectations for functioning and symptom control, discordant estimation of asthma control, lack of routines for administering medication, and concerns about asthma medications.<sup>12</sup> Results

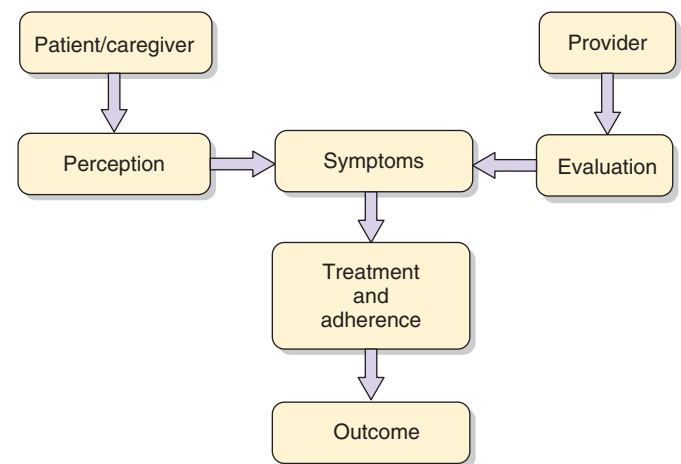

**Figure 33-1** Interaction between patient/caregiver and provider. Inaccurate reporting of symptoms or inadequate assessment can lead to suboptimal treatment and poor outcome.

TABLE 33-1 Factors Contributing to Asthma Morbidity in Children of Lower Socioeconomic Status				
Access to Care	Environment	Host	Psychosocial	Adherence
Underdiagnosis	Allergens	Genetics	Maternal factors	Child/caregiver
Undertreatment	Irritants	Obesity	Child factors	Healthcare provider
Availability of specialty care		Asthma knowledge	Stress	
Insurance			Violence	
			Housing	



**BOX 33-1 PREDISPOSING FACTORS FOR POOR ADHERENCE**

Insufficient asthma knowledge  
 Inability to translate knowledge into practice  
 Negative beliefs about medications  
 Cultural beliefs about medications  
 Low parental expectations for symptom control  
 Competing priorities  
 Suboptimal communication between parent and healthcare provider

of a multivariate analysis suggested that low parental expectations and competing priorities mediated the association of race/ethnicity and poor asthma control. Complementary and alternative medicine use in children with asthma is high. Usage is highest in black, poor, lesser educated parents and in children with persistent asthma.<sup>33</sup>

The level of responsibility for asthma management increases with age in inner city children.<sup>17</sup> However, older children may still be ill-equipped to manage the illness independently.<sup>34</sup> A complicating factor is that there is discordance between the caregiver and the child regarding responsibility for the management of the child's asthma.<sup>17</sup>

**ACCESS TO CARE**

Lack of adequate health insurance is an important barrier to healthcare services for children in the USA. Diagnosis and treatment of asthma are related to healthcare coverage.<sup>35</sup> However, some evidence suggests that asthma-related healthcare differences across groups might exist independently of financial barriers.<sup>11</sup> Despite very high levels of healthcare coverage and access to primary care in an urban population, the overall quality of asthma care and management falls short of that recommended by national guidelines.<sup>36</sup> In the NCICAS, 91% of children had health insurance but only 28% received anti-inflammatory medications.<sup>14</sup> This suggests that the delivery or quality of care may contribute to poor outcome. Access to care from asthma specialists is reduced for those who are poor and belong to an ethnic minority. Physicians underprescribe controller medication for inner city children despite guidelines recommending the use of anti-inflammatory medications for persistent asthma.<sup>22,23,32</sup> Furhman et al reported that children with asthma hospitalized for an exacerbation had been consistently poorly controlled during the previous year. They were undertreated and insufficiently educated about asthma.<sup>37</sup> However physician adherence to guidelines will not translate into appropriate treatment without attention being paid to caregiver-physician communication.<sup>32</sup>

**PSYCHOSOCIAL FACTORS**

Behavioral and psychosocial factors can affect asthma morbidity. There are variations in asthma morbidity in neighborhoods with low SES. This indicates that asthma morbidity cannot be explained solely by economic factors and that community factors may be important. Exposure to violence was independently associated with asthma morbidity after simultaneous adjustment for income, employment status, caregiver education, housing problems and other adverse life events, which suggests that exposure to violence is not merely a marker for

these other factors. Increased exposure to violence predicts increased symptomatology in a graded fashion.<sup>38</sup> Children spend more time indoors because of fear of violence, which could potentially increase exposure to indoor allergens and irritants.<sup>38</sup> Inner city school children with asthma whose primary caregivers perceived the neighborhood to be unsafe had an increased likelihood of poorly controlled asthma, increased use of rescue medication use and more limitation in activity and nighttime symptoms compared to participants living in safe neighborhoods.<sup>39</sup>

Psychosocial factors, particularly the mental health of children and caregivers, are significant factors in predicting asthma morbidity. In the NCICAS, caregiver mental health as assessed by the Brief Symptom Inventory revealed that children of caregivers who had psychological symptoms were almost twice as likely to be hospitalized for asthma.<sup>40</sup> In adolescents with asthma, number of asthma symptoms, asthma-related school absenteeism, physician visits for asthma and hospitalization for asthma were significantly associated with the number of stressful events, independent of environmental exposures and sociodemographic factors.<sup>41</sup> Interventions that do not address psychosocial issues may have limited impact.

**INDOOR ENVIRONMENTAL EXPOSURES**

Attention to the indoor environment is of particular importance because children living in urban areas spend approximately 70% of their time indoors, where they are exposed to irritants, allergens and endotoxin.<sup>42</sup> There are many sources of indoor exposure penetrating from outdoor air and generating from indoor sources.

Exposure to environmental tobacco smoke (ETS) in children with asthma living in inner cities is high. Studies in inner cities report that more than half of children with asthma have one or more smokers in the household and over one third of primary caregivers of children with asthma are smokers.<sup>14</sup> Measurement of cotinine levels in children reveal even higher levels of personal exposure ranging from 38% to 69%.<sup>14,43,44</sup> African American children are more likely to be exposed than Latino children.<sup>43,44</sup>

Particulate matter (PM) is a major source of indoor air pollution in inner city homes. Indoor concentrations of PM are related to combustion products as well as to variation in ventilation and air filtration.<sup>45,46</sup> Penetration of particles from outdoor sources contributes about 25% of the indoor concentration. The major indoor source is smoking. In the Inner-City Air Pollution Study (ICAP) the mean indoor value of fine particulate matter (PM<sub>2.5</sub>) in smoking homes was 46.5 µg/m<sup>3</sup> compared with 17.8 µg/m<sup>3</sup> in nonsmoking homes. Frying, smoky cooking events, burning incense and cleaning activities such as sweeping are additional sources of PM.<sup>22</sup> Indoor particulate matter has also been shown to be associated with an increase in asthma symptoms and rescue medication use.<sup>47,48</sup>

Nitrogen dioxide is a by-product of combustion sources. Household appliances fueled by gas such as gas stoves or kerosene heaters are the major sources of indoor NO<sub>2</sub>.<sup>49</sup> Gas stoves are commonly found in inner city homes. In the seven cities participating in NCICAS, 89% of households had gas stoves.<sup>50</sup> Ventilating with exhaust fans reduces indoor NO<sub>2</sub> levels significantly but the majority of households in NCICAS did not have proper venting. Measurements in inner city households demonstrate high indoor concentrations of NO<sub>2</sub> often

exceeding the US Environmental Protection Agency outdoor standard (53 ppb).<sup>50,51</sup> Asthmatic children exposed to NO<sub>2</sub> indoors are at risk for increased asthma morbidity.<sup>50–52</sup> NO<sub>2</sub> increases the risk of asthmatic exacerbations following respiratory infections, even at relatively low levels of exposure.<sup>53</sup>

Allergens can be produced from pests (mites, cockroaches, rodents), pets (cats, dogs), plants (pollen) and fungi (mold spores). Cockroach, mice and molds are prevalent in urban areas but there are geographic variations in exposures and sensitization.<sup>54</sup> African American, Mexican American and Puerto Rican children are more likely to be sensitized to cockroach and dust mites.<sup>55,56</sup>

Exposure to indoor allergens among sensitized asthmatic patients is associated with greater asthma severity and increased healthcare utilization. In sensitized children, indoor exposures to total fungi and to *Penicillium* species were associated with significant increases in unscheduled visits, even after controlling for outdoor fungal levels.<sup>57</sup> In NCICAS, children exposed and sensitized to cockroach had more days of wheeze, unscheduled doctor visits and hospitalizations compared to those children who were only exposed, only sensitized or neither exposed nor sensitized.<sup>58</sup> In Baltimore, Maryland, among those who were sensitized and exposed to both cockroach and mouse, mouse appeared to be the stronger driver of worse asthma.<sup>59</sup> Cat, cockroach, rodent and house dust mite exposure in children has been associated with asthma exacerbations in a dose dependent fashion.<sup>58,60</sup>

Asthma guidelines recommend reducing exposure to relevant allergens to reduce inflammation, symptoms and need for medication. A tailored, multifaceted approach to allergen avoidance in the home, based on skin test sensitivity, is emphasized because steps to reduce single allergens have been shown to be largely ineffective.<sup>61–63</sup> Environmental control represents a financial and practical burden for both patients and society. Successful approaches need to set realistic goals that account for limitations imposed by the inner city setting. Necessary resources may not be available for optimal environmental control. For example, only 38% of homes in NCICAS had functioning vacuum cleaners.<sup>64</sup> Third party payers do not reimburse for supplies and equipment needed by patients to reduce environmental triggers in their homes, nor are visiting homecare workers consistently trained in evaluating homes for triggers and educating patients about household allergen reduction.

## OUTDOOR ENVIRONMENTAL EXPOSURES

Higher levels of ambient air pollutants are associated with increased asthma morbidity.<sup>65,66</sup> Particulate matter (<10 µm [PM<sub>10</sub>] and <2.5 µm in aerodynamic diameter [PM<sub>2.5</sub>]) is a collection of mostly inorganic pollutants that has been associated with adverse respiratory effects and exacerbations of asthma. PM<sub>2.5</sub> can penetrate deep into the lung. Increasing asthma morbidity has been observed during a period of declining air pollution. However, populations living in underserved urban communities remain at higher risk because improvement in ambient air quality is not equally distributed among all communities.<sup>67</sup>

Many children living in inner cities live in close proximity to highways and businesses that rely on high volumes of truck traffic. Using the elemental carbon (EC) portion of PM<sub>2.5</sub> as a marker of diesel exhaust emissions, Spira-Cohen et al found increasing risk of adverse respiratory outcomes with increasing

exposures to EC concentrations in inner city children with asthma.<sup>68</sup> Using an in vitro model, Wu et al demonstrated that near-roadway PM produced greater inflammatory response than urban background PM. PM induced higher levels of inflammatory cytokines IL-6, IL-8 and TNF-α.<sup>69</sup>

## OBESITY

There has been a parallel rise in the prevalence of obesity and asthma over the last few decades. Blacks and Hispanics experience higher rates of obesity than whites. Low SES is also associated with higher rates of obesity.<sup>70</sup> Epidemiologic studies show an association between obesity and asthma prevalence and severity. Over one third of children with asthma in a multi-center inner city study were obese compared to 17% of the general population of children in the USAs.<sup>70,71</sup> Obese children are not only more likely to develop asthma but are more likely to have increased severity resulting in greater healthcare utilization.<sup>72</sup> In a longitudinal study obesity was associated with poorer asthma control in females.<sup>71</sup> One study found that in an urban, predominantly African American population, the effects of indoor PM<sub>2.5</sub> and NO<sub>2</sub> exposure on asthma symptoms were greater in overweight and obese than normal-weight children and adolescents.<sup>73</sup>

## Interventions

Many interventions have been developed and implemented in a variety of settings, including EDs, hospitals, clinics, schools and home. The approaches include educational interventions aimed at patients and their families or healthcare providers, case management, and environmental control strategies. The limitations of studies of interventions are that the majority have not been subjected to randomized controlled clinical trials, have small sample sizes, are not culturally sensitive or do not examine the cost-effectiveness. The importance of a proper study design to assess new interventions is underscored by the fact that there is a significant improvement in outcome in children with asthma enrolled in control arms of these trials.<sup>74</sup> Therefore caution needs to be exercised in concluding that an intervention is efficacious when using a pre-post study design.

## THERAPY

Currently available medications for the management of asthma used according to published guidelines and with good adherence and follow-up are highly effective in controlling asthma symptoms in inner city children. A guideline-based approach improved asthma control in several studies enrolling moderate to severe asthmatics.<sup>75,76</sup> For example, Figure 33-2 demonstrates that adolescents in a control arm of a study receiving guideline-based care improved quickly and maintained control over the course of the 1-year treatment period. Of interest despite good control of symptoms, children and adolescents continue to experience exacerbations at a high rate, particularly during the fall months. A study by the NIAID Inner-City Asthma Consortium showed a reduction in the frequency of fall asthma exacerbations when omalizumab (an anti-IgE drug) was added to guidelines-directed treatment.<sup>77</sup> The cost of this treatment is high and studies are underway to determine if a shorter course of treatment initiated prior to returning to school prevents the fall exacerbations.

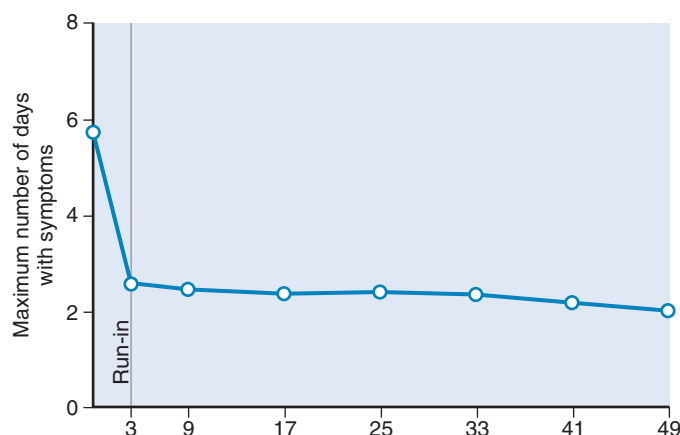

**Figure 33-2** The response to guideline-based care. The graph shows symptom days per 2 weeks averaged over 1 year in adolescents in a control arm of a study given guideline-based care. (Adapted from Szeffler SJ, Mitchell H, Sorkness CA, et al. Management of asthma based on exhaled nitric oxide in addition to guideline-based treatment for inner-city adolescents and young adults: a randomised controlled trial. *Lancet* 2008;372(9643):1065–72.)

## EMERGENCY DEPARTMENT INTERVENTIONS

Utilization of the ED for children with asthma living in inner cities is high. Previous ED visits are strong predictors of subsequent ED visits.<sup>78</sup> Interventions targeting high-risk children might be expected to have an impact on asthma morbidity because these patients are likely to have severe asthma and poor asthma management skills. A number of strategies have been studied but the results have been conflicting.

A three-part ED-based intervention including asthma screening, viewing an educational video addressing beliefs and a mailed reminder did not improve follow-up or outcomes.<sup>79</sup> A randomized trial by Teach et al evaluated a single comprehensive follow-up visit after ED discharge that included education, initiating controller medications and scheduling a follow-up visit with a primary care provider.<sup>80</sup> The intervention improved asthma treatment adherence, symptom control, quality of life and healthcare use in this population of urban, largely disadvantaged, and minority children. It decreased the rate of unscheduled visits for asthma during the entire 6-month follow-up period. There was no effect of the intervention on follow-up with the primary care provider. A review of studies comparing usual care for asthma to more intensive educational programs concluded that asthma education aimed at children and their caregiver who present to the ED for acute exacerbations resulted in lower risk of future ED visits and hospital admission. It remained unclear as to what type, duration and intensity of educational packages were the most effective in reducing acute care utilization.<sup>81</sup> A Joint Task Force Report reviewing ED interventions recommended among other things that patients seen in the ED should have their asthma characterized and that a follow-up appointment with a primary care physician or asthma specialist be made before leaving the ED and if possible a telephone reminder.<sup>82</sup>

## SCHOOL-BASED INTERVENTIONS

Various strategies have been used in school-based interventions but few have been subjected to randomized controlled clinical

trials. Many programs have had trouble fully implementing their plans because school staff, healthcare providers and parents all find it difficult to commit sufficient time and effort to establish new patterns of cooperation. The success of school-based programs for asthma is dependent on a partnership with families and the healthcare system. Individual schools have different capabilities to deal with school health in general and with asthma in particular. The strategy to improve asthma outcomes that is most likely to succeed in a particular school will be dependent on the resources that each component of the partnership can contribute.<sup>83</sup>

Two randomized studies evaluated supervised asthma therapy in urban schools. Both provided medication at no cost. Gerald et al reported improved asthma control among urban school children.<sup>84</sup> In addition to administering medication in school, Halterman et al made guideline-based dosage adjustments and gave a home-based environmental tobacco smoke reduction program for smoke-exposed children.<sup>85</sup> Compared with usual care, the program improved asthma symptoms and decreased exacerbations.

Another strategy is to focus on self-management skills. Evans et al provided self-management education in inner city elementary school children.<sup>86</sup> The program emphasized the child's responsibility for recognizing symptoms and taking appropriate management steps. Children in treatment schools had increased management skills, fewer symptoms of asthma and improved school performance. A school-based intervention for adolescents used both group and tailored individual sessions and included education for their medical providers. Relative to control subjects, students in the intervention group reported more confidence to manage their asthma, taking more steps to prevent symptoms, greater use of controller medication, and fewer symptoms, acute care visits, hospitalizations and school absences due to asthma.<sup>87</sup>

Although not evaluated in controlled clinical trials, school-based mobile clinics have been used in several cities in the USA. The model attempts to reduce barriers to delivering effective care to underserved children with asthma. The mobile clinics are staffed by specialty trained asthma providers and integrate strategies for case identification, community outreach, continuity of care, structured healthcare encounters and patient tracking. Comparison of pre and post year data for subjects enrolled in the program for at least 1 year revealed reductions in the percentage of patients reporting ED visits, hospitalizations and missed school days.<sup>88</sup>

## PROVIDER TARGETED INTERVENTIONS

Despite the findings that adherence to guidelines by providers is suboptimal, there are few rigorously designed trials of interventions aimed at providers in inner cities. A systematic review of provider interventions concluded that decision support tools, feedback and audit, and clinical pharmacy support were most likely to improve provider adherence to asthma guidelines, as measured through healthcare process outcomes.<sup>89</sup>

Training of staff in clinics providing care to inner city minority children coupled with administrative support for change in practice behavior increased the number of patients with asthma receiving continuing care and improved the quality of care they received compared to control clinics.<sup>90</sup> Health outcomes were not reported. The relative contributions of the training program and the strong organizational commitment by the

local government health department to the outcomes could not be distinguished. Easy Breathing is a program instituted in primary care clinics serving inner city communities. The program had a positive effect on clinicians' knowledge and adherence to asthma guidelines as evaluated using a pre-post study design.<sup>91</sup>

The Inner City Asthma Study evaluated a decision support system with feedback to providers.<sup>92</sup> An automated computer program provided information to the child's primary care physician along with guideline-based treatment recommendations. The computerized algorithm analyzed each child's current level of symptoms, health care utilization and medication use and, on the basis of National Asthma Education and Prevention Program guidelines, recommended increased treatment, decreased treatment or no change. Children whose primary care physicians received these computerized letters had more follow-up care visits, received increased treatment more rapidly when warranted and had fewer ED visits.

### ENVIRONMENTAL INTERVENTIONS

Asthma management guidelines emphasize the need for individualized environmental control measures in the treatment of asthma. In a small double-blind randomized trial in a low-income population, house dust mite mitigation intervention reduced dust mite levels and bronchial responsiveness but not symptoms or quality of life.<sup>93</sup> Attempts to reduce cockroach allergens in the home have had varied success.<sup>94</sup> Integrated pest management, which consists of filling holes with copper mesh, vacuuming and cleaning, and low-toxicity pesticides and traps, can control cockroach infestation. Reduction of cockroach allergen levels is feasible and can be maintained in some, but not all, multifamily dwellings in the inner city.<sup>95,96</sup>

Limitations in single allergen avoidance trials have directed attention to a multifaceted approach to allergen reduction. Krieger used community health workers to provide in-home environmental assessments, education, support for behavior change and resources.<sup>97</sup> The intervention reduced asthma symptom days and urgent health services use while improving caregiver quality-of-life score. Butz et al randomly assigned children with asthma residing with a smoker to interventions consisting of air cleaners only, air cleaners plus a health coach, or delayed air cleaner (control).<sup>98</sup> The use of air cleaners resulted in a reduction in indoor PM concentrations and an increase in symptom-free days. The intervention did not reduce exposure to secondhand smoke as measured by air nicotine or urine cotinine concentrations.

The Inner City Asthma Study (ICAS) reported on a multifaceted home-based environmental intervention for inner city children with asthma. Intervention was tailored to each patient's sensitization and environmental risk profile, utilizing a series of modules to reduce home allergen exposure.<sup>99</sup> Individuals who were randomized to environmental intervention demonstrated significantly fewer symptom days during the intervention year and during the year following intervention compared to individuals in the control group.<sup>75</sup> Cost of the intervention ranged from \$750 to \$1,000 per patient, estimated to cost \$27 per symptom-free day.<sup>100</sup> In another multifaceted allergen avoidance study, Carter et al studied the effect of avoidance of dust and cockroach in a group of inner city children with asthma. While there was no overall improvement in the intervention group compared with control, significant reduction in acute

visits for asthma was demonstrated for mite-allergic children who had a significant decrease in exposure to mite allergen.<sup>101</sup>

### TECHNOLOGY-BASED INTERVENTIONS

There are few rigorously assessed computer-based interventions for asthma. These have had limited success. An educational software program did not produce greater improvement than occurred with review of traditional written materials.<sup>102</sup> A trial of a computer-assisted instructional (CAI) game on asthma symptoms was not effective in improving asthma symptoms.<sup>103</sup> In contrast, a small study found that computer-delivered self-management education used at home scored higher on prevention and treatment strategies and enhanced children's sense of self-efficacy.<sup>104</sup>

Emerging health information technologies designed to improve patient-physician communication can be used successfully in inner city populations. Among children and adolescents in a low-income, urban population, a text messaging intervention compared with usual care was associated with a modest improvement in the rate of influenza vaccination.<sup>105</sup> Smartphone applications to monitor peak flow or asthma symptoms are available but their use has not been evaluated in controlled clinical trials. The technologies are developing rapidly and have the potential of delivering targeted interventions to individuals.<sup>106</sup> An important barrier to overcome with interventions requiring daily monitoring or daily diaries is decreased compliance with monitoring over time that has been observed in inner city children with asthma.<sup>107</sup>

### MULTIFACTORIAL INTERVENTIONS

The first phase of the NCICAS showed that a multitude of factors are responsible for asthma morbidity, including adherence, access to care and physician undertreatment. Other risk factors involve the living conditions, social welfare and mental health issues of the family. These risk factors may interfere with the ability of the family to give sufficient attention to the child's asthma. It also became apparent that asthma management was not the responsibility solely of the physician but of the family as well. For an intervention in the inner city to succeed, it must address a variety of risk factors, not all of which would be the same among individuals.

The asthma counselor intervention program developed by NCICAS used social workers to empower families to increase asthma self-management and to improve their communication with primary care providers. A risk profile was prepared for each child on the basis of assessments of skin test sensitivities, environmental exposures, psychosocial factors, difficulty accessing care, exposure to pets or smoking and other factors. The multifactorial intervention was tailored to each child using specific modules, each of which addressed specific risk factors. This tailored intervention approach was found to be highly effective in reducing asthma symptoms among the children.<sup>108</sup>

Home-based educational interventions may lead to modest short-term improvements in asthma outcomes among inner city children. A home-based intervention using asthma counselors modeled after the NCICAS intervention and culturally adapted for Puerto Rican families found no significant differences in symptom-free days between the intervention and control groups, although significant reductions were observed in symptom-free nights, ED visits and hospitalizations.<sup>109</sup>



A randomized, parallel group, controlled trial found that asthma education led to improved adherence and decreased morbidity compared with usual care. The education consisted of five home visits by trained asthma educators reviewing medications, identifying barriers and discussing beliefs and concerns. Addition of feedback based on objective adherence data did not improve outcomes over education alone.<sup>110</sup> A nurse-led education program in Glasgow, Scotland, for children hospitalized for asthma who were predominantly of lower social class implemented home management training that incorporated written and verbal information and was reinforced with outpatient follow-up appointments and telephone advice.<sup>111</sup> A review suggested that culture-specific education programs for children from minority groups are effective in improving asthma-related outcomes of quality of life, asthma knowledge and rate of asthma exacerbations and asthma control. Thus asthma education programs for children from minority groups with asthma would be more likely to succeed if they were culture specific.<sup>112</sup>

One randomized controlled trial evaluated usual care versus 2-year asthma coach intervention for low-income, Medicaid-covered, African American children.<sup>113</sup> The coaches were two African American women with high school education residing in the same general neighborhoods as the participants. The coach intervention was designed to achieve standardization through a set of key behavioral objectives and a planned schedule of contacts as well as flexibility through a nondirective approach and individualization of key behavioral objectives. The asthma coach intervention achieved lower prevalence of hospitalizations. The intervention did not lead to a decrease in emergency visits that did not require hospitalization. A subsequent study assigned lay workers to coach parents to improve important aspects of care and reduce morbidity in a high-risk population.<sup>114</sup> Coaches were taught the pathogenesis, symptoms and management principles of asthma and how to communicate effectively, provide psychosocial support to parents during times of stress, assess parents' readiness to engage in targeted management strategies, and promote behavior change. Parental coaching increased asthma monitoring visits, including visits with documented controller medications, but these changes were not associated with fewer ED visits.

Walders et al used an interdisciplinary intervention consisting of a written asthma treatment plan, asthma education, an asthma risk assessment, problem-solving and access to a 24-hour nurse advice line.<sup>115</sup> The intervention group did not show evidence of reduced asthma symptoms or improved measures of quality of life beyond the changes demonstrated by the comparison group. However, the interdisciplinary intervention group had less frequent healthcare utilization for asthma over the course of the 1-year follow-up period.<sup>115</sup>

## Community-Wide Asthma Coalitions

Community-wide asthma coalitions are collaborative efforts at the local level to achieve asthma control by bringing together diverse stakeholders that include healthcare providers, grassroots groups, voluntary and government agencies and business

and industry who collectively implement strategies to improve asthma outcomes. The results are mixed.

Fisher et al evaluated a neighborhood asthma coalition in St. Louis. The coalition included educational programs for parents and children, promotional activities and individualized support provided by trained neighborhood residents. Acute care rates decreased for both the coalition and control groups from the year before intervention to the last year of intervention but with no significant differences between the coalition and control groups.<sup>116</sup>

Allies Against Asthma is a group of community-based coalitions working to improve asthma outcomes in vulnerable children. The evaluation of the program indicated that mobilizing diverse stakeholders and focusing on policy and system changes can generate significant reductions in healthcare use for vulnerable children with asthma.<sup>117</sup> What is evident is that results from the asthma coalitions are not instantaneous but become evident over the long term.

## Conclusions

The management of asthma in inner cities presents a challenge that requires participation of multiple stakeholders. Major challenges to preventive asthma care are encountered by inner city children and include family and patient attitudes and beliefs, lack of access to quality medical care, psychosocial and environmental factors. The myriad factors contributing to morbidity are interdependent. It is clear that a 'one size fits all' approach is unlikely to be successful. There are lessons to be learned from the characteristics of successful interventions. It is important to assess individual risk factors. Programs require flexibility so that elements can be tailored to the individual. Guideline-based care will not succeed unless attention is paid to psychosocial and societal issues that are barriers to care. For example, a family with good asthma knowledge may not be able to overcome barriers such as no access to after-hours clinics or lack of insurance coverage for spacers.

The interventions outlined in this chapter demonstrate that positive outcomes can be achieved. However, translating research into practice is the ultimate goal and this presents another major challenge. An attempt to disseminate the NCICAS asthma counselor model at 22 sites across the country by the Centers for Disease Control exemplifies some of the difficulties. Implementation varied among sites. Retention was related to type and location of the sites, ease of obtaining written plans, language and ethnicity of asthma counselor and availability of on-site allergy testing.<sup>118</sup> A report from the Merck Childhood Asthma Network discussed the adaptation of evidence-based interventions at five sites and documented the site-to-site variations in fidelity to the original interventions.<sup>119</sup> More real world data on implementation and barriers are needed from those implementing community interventions in order to refine programs and reduce morbidity.<sup>120</sup>

The complete reference list can be found on the companion Expert Consult website at <http://www.expertconsult.inkling.com>.

## KEY REFERENCES

5. Bryant-Stephens T. Asthma disparities in urban environments. *J Allergy Clin Immunol* 2009;123:1199–206.
14. Kattan M, Mitchell H, Eggleston P, Gergen P, Crain E, Redline S, et al. Characteristics of inner-city children with asthma: the National Cooperative Inner-City Asthma Study. *Pediatr Pulmonol* 1997;24:253–62.
24. Morton RW, Everard ML, Elphick HE. Adherence in childhood asthma: the elephant in the room. *Arch Dis Child* 2014;99:949–53.
47. Breyse PN, Diette GB, Matsui EC, Butz AM, Hansel NN, McCormack MC. Indoor air pollution and asthma in children. *Proc Am Thorac Soc* 2010;7:102–6.
75. Morgan WJ, Crain EF, Gruchalla RS, O'Connor GT, Kattan M, Evans R 3rd, et al. Results of a home-based environmental intervention among urban children with asthma. *N Engl J Med* 2004;351:1068–80.
81. Boyd M, Lasserson TJ, McKean MC, Gibson PG, Ducharme FM, Haby M. Interventions for educating children who are at risk of asthma-related emergency department attendance. *Cochrane Database Syst Rev* 2009;2:CD001290.
83. Bruzzese JM, Evans D, Kattan M. School-based asthma programs. *J Allergy Clin Immunol* 2009;124:195–200.
89. Okelo SO, Butz AM, Sharma R, Diette GB, Pitts SI, King TM, et al. Interventions to modify health care provider adherence to asthma guidelines: a systematic review. *Pediatrics* 2013;132:517–34.
108. Evans R 3rd, Gergen PJ, Mitchell H, Kattan M, Kercksmar C, Crain E, et al. A randomized clinical trial to reduce asthma morbidity among inner-city children: results of the National Cooperative Inner-City Asthma Study. *J Pediatr* 1999;135:332–8.
119. Lara M, Bryant-Stephens T, Damitz M, Findley S, Gavillan JG, Mitchell H, et al. Balancing 'fidelity' and community context in the adaptation of asthma evidence-based interventions in the 'real world'. *Health Promot Pract* 2011; 12(6 Suppl. 1):63S–72S.

## REFERENCES

- Lai CK, Beasley R, Crane J, Foliaki S, Shah J, Weiland S, et al. Global variation in the prevalence and severity of asthma symptoms: phase three of the International Study of Asthma and Allergies in Childhood (ISAAC). *Thorax* 2009;64:476–83.
- Crain EF, Weiss KB, Bijur PE, Hersh M, Westbrook L, Stein RE. An estimate of the prevalence of asthma and wheezing among inner-city children. *Pediatrics* 1994;94:356–62.
- Halfon N, Newacheck PW. Childhood asthma and poverty: differential impacts and utilization of health services. *Pediatrics* 1993;91:56–61.
- Gottlieb DJ, Beiser AS, O'Connor GT. Poverty, race, and medication use are correlates of asthma hospitalization rates. A small area analysis in Boston. *Chest* 1995;108:28–35.
- Bryant-Stephens T. Asthma disparities in urban environments. *J Allergy Clin Immunol* 2009;123:1199–206.
- Gold DR, Wright R. Population disparities in asthma. *Annl Rev Public Health* 2005;26:89–113.
- Netuveli G, Hurwitz B, Levy M, Fletcher M, Barnes G, Durham SR, et al. Ethnic variations in UK asthma frequency, morbidity, and health-service use: a systematic review and meta-analysis. *Lancet* 2005;365:312–17.
- Beck AF, Huang B, Simmons JM, Moncrief T, Sauters HS, Chen C, et al. Role of financial and social hardships in asthma racial disparities. *Pediatrics* 2014;133:431–9.
- Jones R, Lin S, Munsie JP, Radigan M, Hwang SA. Racial/ethnic differences in asthma-related emergency department visits and hospitalizations among children with wheeze in Buffalo, New York. *J Asthma* 2008;45:916–22.
- Cohen RT, Celedon JC, Hinckson VJ, Ramsey CD, Wakefield DB, Weiss ST, et al. Health-care use among Puerto Rican and African-American children with asthma. *Chest* 2006;130:463–71.
- Zoratti EM, Havstad S, Rodriguez J, Robens-Paradise Y, Lafata JE, McCarthy B. Health service use by African Americans and Caucasians with asthma in a managed care setting. *Am J Respir Crit Care Med* 1998;158:371–7.
- Smith LA, Bokhour B, Hohman KH, Miroshnik I, Kleinman KP, Cohn E, et al. Modifiable risk factors for suboptimal control and controller medication underuse among children with asthma. *Pediatrics* 2008;122:760–9.
- Eggleston EM, Finkelstein JA. Finding the role of health care in population health. *JAMA* 2014;311:797–8.
- Kattan M, Mitchell H, Eggleston P, Gergen P, Crain E, Redline S, et al. Characteristics of inner-city children with asthma: the National Cooperative Inner-City Asthma Study. *Pediatr Pulmonol* 1997;24:253–62.
- Lalloo UG, Walters RD, Adachi M, de Guia T, Emelyanov A, Fritsch CC, et al. Asthma programmes in diverse regions of the world: challenges, successes and lessons learnt. *Int J Tuberc Lung Dis* 2011;15:1574–87.
- Britto MT, Vockell AL, Munafò JK, Schoettker PJ, Wimberg JA, Pruett R, et al. Improving outcomes for underserved adolescents with asthma. *Pediatrics* 2014;133:e418–27.
- Wade S, Weil C, Holden G, Mitchell H, Evans R 3rd, Kruszon-Moran D, et al. Psychosocial characteristics of inner-city children with asthma: a description of the NCICAS psychosocial protocol. National Cooperative Inner-City Asthma Study. *Pediatr Pulmonol* 1997;24:263–76.
- Wade SL, Holden G, Lynn H, Mitchell H, Ewart C. Cognitive-behavioral predictors of asthma morbidity in inner-city children. *J Dev Behav Pediatr* 2000;21:340–6.
- Holgate ST, Price D, Valovirta E. Asthma out of control? A structured review of recent patient surveys. *BMC Pulm Med* 2006;6(Suppl. 1):S2.
- Wisnivesky JP, Kattan M, Evans D, Leventhal H, Musumeci-Szabo TJ, McGinn T, et al. Assessing the relationship between language proficiency and asthma morbidity among inner-city asthmatics. *Med Care* 2009;47:243–9.
- Halfon N, Newacheck PW, Wood DL, St Peter RF. Routine emergency department use for sick care by children in the United States. *Pediatrics* 1996;98:28–34.
- Warman KL, Silver EJ, Stein RE. Asthma symptoms, morbidity, and anti-inflammatory use in inner-city children. *Pediatrics* 2001;108:277–82.
- Butz AM, Eggleston P, Huss K, Kolodner K, Rand C. Nebulizer use in inner-city children with asthma: morbidity, medication use, and asthma management practices. *Arch Pediatr Adolesc Med* 2000;154:984–90.
- Morton RW, Everard ML, Elphick HE. Adherence in childhood asthma: the elephant in the room. *Arch Dis Child* 2014;99:949–53.
- Bender B, Wamboldt FS, O'Connor SL, Rand C, Szeffler S, Milgrom H, et al. Measurement of children's asthma medication adherence by self report, mother report, canister weight, and Doser CT. *Ann Allergy Asthma Immunol* 2000;85:416–21.
- Bruzzese JM, Stepney C, Fiorino EK, Bornstein L, Wang J, Petkova E, et al. Asthma self-management is sub-optimal in urban Hispanic and African American/black early adolescents with uncontrolled persistent asthma. *J Asthma* 2012;49:90–7.
- Leickly FE, Wade SL, Crain E, Kruszon-Moran D, Wright EC, Evans R 3rd. Self-reported adherence, management behavior, and barriers to care after an emergency department visit by inner city children with asthma. *Pediatrics* 1998;101:E8.
- Yoos HL, Kitzman H, McMullen A. Barriers to anti-inflammatory medication use in childhood asthma. *Ambul Pediatr* 2003;3:181–90.
- George M. Health beliefs, treatment preferences and complementary and alternative medicine for asthma, smoking and lung cancer self-management in diverse Black communities. *Patient Educ Couns* 2012;89:489–500.
- Handelman L, Rich M, Bridgemohan CF, Schneider L. Understanding pediatric inner-city asthma: an explanatory model approach. *J Asthma* 2004;41:167–77.
- Van Sickle D, Wright AL. Navajo perceptions of asthma and asthma medications: clinical implications. *Pediatrics* 2001;108:E11.
- Riekert KA, Butz AM, Eggleston PA, Huss K, Winkelstein M, Rand CS. Caregiver-physician medication concordance and undertreatment of asthma among inner-city children. *Pediatrics* 2003;111:e214–20.
- Sidora-Arcoleo K, Yoos HL, McMullen A, Kitzman H. Complementary and alternative medicine use in children with asthma: prevalence and sociodemographic profile of users. *J Asthma* 2007;44:169–75.
- Bruzzese JM, Bonner S, Vincent EJ, Sheares BJ, Mellins RB, Levison MJ, et al. Asthma education: the adolescent experience. *Patient Educ Couns* 2004;55:396–406.
- Freeman NC, Schneider D, McGarvey P. The relationship of health insurance to the diagnosis and management of asthma and respiratory problems in children in a predominantly Hispanic urban community. *Am J Public Health* 2003;93:1316–20.
- Reeves MJ, Bohm SR, Korzeniewski SJ, Brown MD. Asthma care and management before an emergency department visit in children in western Michigan: how well does care adhere to guidelines? *Pediatrics* 2006;117(4 Pt 2):S118–26.
- Fuhrman C, Dubus JC, Marguet C, Delacourt C, Thumerelle C, de Blic J, et al. Hospitalizations for asthma in children are linked to undertreatment and insufficient asthma education. *J Asthma* 2011;48:565–71.
- Wright RJ, Mitchell H, Visness CM, Cohen S, Stout J, Evans R, et al. Community violence and asthma morbidity: the Inner-City Asthma Study. *Am J Public Health* 2004;94:625–32.
- Kopel LS, Gaffin JM, Ozonoff A, Rao DR, Sheehan WJ, Friedlander JL, et al. Perceived neighborhood safety and asthma morbidity in the School Inner-City Asthma Study. *Pediatr Pulmonol* 2015;50:17–24.
- Weil CM, Wade SL, Bauman LJ, Lynn H, Mitchell H, Lavigne J. The relationship between psychosocial factors and asthma morbidity in inner-city children with asthma. *Pediatrics* 1999;104:1274–80.
- Turyk ME, Hernandez E, Wright RJ, Freels S, Slezak J, Contreras A, et al. Stressful life events and asthma in adolescents. *Pediatr Allergy Immunol* 2008;19:255–63.
- Klepeis NE, Nelson WC, Ott WR, Robinson JP, Tsang AM, Switzer P, et al. The National Human Activity Pattern Survey (NHAPS): a resource for assessing exposure to environmental pollutants. *J Expo Anal Environ Epidemiol* 2001;11:231–52.
- Kumar R, Curtis LM, Khiani S, Moy J, Shalowitz MU, Sharp L, et al. A community-based study of tobacco smoke exposure among inner-city children with asthma in Chicago. *J Allergy Clin Immunol* 2008;122:754–9 e1.
- Ehrlich R, Kattan M, Godbold J, Saltzberg DS, Grimm KT, Landrigan PJ, et al. Childhood asthma and passive smoking. Urinary cotinine as a biomarker of exposure. *Amer Rev Respir Dis* 1992;145:594–9.
- Sarnat JA, Koutrakis P, Suh HH. Assessing the relationship between personal particulate and gaseous exposures of senior citizens living in Baltimore, MD. *J Air Waste Manag Assoc* 2000;50:1184–98.
- Wallace LA, Mitchell H, O'Connor GT, Neas L, Lippmann M, Kattan M, et al. Particle concentrations in inner-city homes of children with asthma: the effect of smoking, cooking, and outdoor pollution. *Environ Health Perspect* 2003;111:1265–72.
- Breyse PN, Diette GB, Matsui EC, Butz AM, Hansel NN, McCormack MC. Indoor air pollution and asthma in children. *Proc Am Thorac Soc* 2010;7:102–6.
- McCormack MC, Breyse PN, Matsui EC, Hansel NN, Williams D, Curtin-Brosnan J, et al. In-home particle concentrations and

- childhood asthma morbidity. *Environ Health Perspect* 2009;117:294–8.
49. Neas LM, Dockery DW, Ware JH, Spengler JD, Speizer FE, Ferris BG Jr. Association of indoor nitrogen dioxide with respiratory symptoms and pulmonary function in children. *Am J Epidemiol* 1991;134:204–19.
  50. Kattan M, Gergen PJ, Eggleston P, Visness CM, Mitchell HE. Health effects of indoor nitrogen dioxide and passive smoking on urban asthmatic children. *J Allergy Clin Immunol* 2007;120:618–24.
  51. Hansel NN, Breyse PN, McCormack MC, Matsui EC, Curtin-Brosnan J, Williams DL, et al. A longitudinal study of indoor nitrogen dioxide levels and respiratory symptoms in inner-city children with asthma. *Environ Health Perspect* 2008;116:1428–32.
  52. Belanger K, Holford TR, Gent JF, Hill ME, Kezik JM, Leaderer BP. Household levels of nitrogen dioxide and pediatric asthma severity. *Epidemiology* 2013;24:320–30.
  53. Chauhan AJ, Inskip HM, Linaker CH, Smith S, Schreiber J, Johnston SL, et al. Personal exposure to nitrogen dioxide (NO<sub>2</sub>) and the severity of virus-induced asthma in children. *Lancet* 2003;361:1939–44.
  54. Gruchalla RS, Pongracic J, Plaut M, Evans R 3rd, Visness CM, Walter M, et al. Inner City Asthma Study: relationships among sensitivity, allergen exposure, and asthma morbidity. *J Allergy Clin Immunol* 2005;115:478–85.
  55. Celedon JC, Sredl D, Weiss ST, Pisarski M, Wakefield D, Cloutier M. Ethnicity and skin test reactivity to aeroallergens among asthmatic children in Connecticut. *Chest* 2004;125:85–92.
  56. Stevenson LA, Gergen PJ, Hoover DR, Rosenstreich D, Mannino DM, Matte TD. Sociodemographic correlates of indoor allergen sensitivity among United States children. *J Allergy Clin Immunol* 2001;108:747–52.
  57. Pongracic JA, O'Connor GT, Muilenberg ML, Vaughn B, Gold DR, Kattan M, et al. Differential effects of outdoor versus indoor fungal spores on asthma morbidity in inner-city children. *J Allergy Clin Immunol* 2010;125:593–9.
  58. Rosenstreich DL, Eggleston P, Kattan M, Baker D, Slavin RG, Gergen P, et al. The role of cockroach allergy and exposure to cockroach allergen in causing morbidity among inner-city children with asthma. *N Engl J Med* 1997;336:1356–63.
  59. Ahluwalia SK, Peng RD, Breyse PN, Diette GB, Curtin-Brosnan J, Aloe C, et al. Mouse allergen is the major allergen of public health relevance in Baltimore City. *J Allergy Clin Immunol* 2013;132:830–5 e1–2.
  60. Perzanowski MS, Platts-Mills TA. Further confirmation of the relevance of cockroach and dust mite sensitization to inner-city asthma morbidity. *Clin Exp Allergy* 2009;39:1291–3.
  61. Gotzsche PC, Johansen HK, Schmidt LM, Burr ML. House dust mite control measures for asthma. *Cochrane Database Syst Rev* 2004;4:CD001187.
  62. Marks GB, Tovey ER, Green W, Shearer M, Salome CM, Woolcock AJ. House dust mite allergen avoidance: a randomized controlled trial of surface chemical treatment and encasement of bedding. *Clin Exp Allergy* 1994;24:1078–83.
  63. Woodcock A, Forster L, Matthews E, Martin J, Letley L, Vickers M, et al. Control of exposure to mite allergen and allergen-impermeable bed covers for adults with asthma. *N Engl J Med* 2003;349:225–36.
  64. Eggleston PA. Environmental causes of asthma in inner city children. The National Cooperative Inner City Asthma Study. *Clin Rev Allergy Immunol* 2000;18:311–24.
  65. Romieu I, Meneses F, Ruiz S, Sierra JJ, Huerta J, White MC, et al. Effects of air pollution on the respiratory health of asthmatic children living in Mexico City. *Am J Respir Crit Care Med* 1996;154(2 Pt 1):300–7.
  66. Slaughter JC, Lumley T, Sheppard L, Koenig JQ, Shapiro GG. Effects of ambient air pollution on symptom severity and medication use in children with asthma. *Ann Allergy Asthma Immunol* 2003;91:346–53.
  67. Claudio L, Torres T, Sanjurjo E, Sherman LR, Landrigan PJ. Environmental health sciences education – a tool for achieving environmental equity and protecting children. *Environ Health Perspect* 1998;106(Suppl. 3):849–55.
  68. Spira-Cohen A, Chen LC, Kendall M, Lall R, Thurston GD. Personal exposures to traffic-related air pollution and acute respiratory health among Bronx schoolchildren with asthma. *Environ Health Perspect* 2011;119:559–65.
  69. Wu W, Muller R, Berhane K, Fruin S, Liu F, Jaspers I, et al. Inflammatory response of monocytes to ambient particles varies by highway proximity. *Am J Respir Cell Mol Biol* 2014;51:802–9.
  70. Ogden CL, Carroll MD, Kit BK, Flegal KM. Prevalence of childhood and adult obesity in the United States, 2011–2012. *JAMA* 2014;311:806–14.
  71. Kattan M, Kumar R, Bloomberg GR, Mitchell HE, Calatroni A, Gergen PJ, et al. Asthma control, adiposity, and adipokines among inner-city adolescents. *J Allergy Clin Immunol* 2010;125:584–92.
  72. Black MH, Zhou H, Takayanagi M, Jacobsen SJ, Koebnick C. Increased asthma risk and asthma-related health care complications associated with childhood obesity. *Am J Epidemiol* 2013;178:1120–8.
  73. Lu KD, Breyse PN, Diette GB, Curtin-Brosnan J, Aloe C, Williams DL, et al. Being overweight increases susceptibility to indoor pollutants among urban children with asthma. *J Allergy Clin Immunol* 2013;131:1017–23, 23 e1–3.
  74. Greineder DK, Loane KC, Parks P. Outcomes for control patients referred to a pediatric asthma outreach program: an example of the Hawthorne effect. *Am J Manag Care* 1998;4:196–202.
  75. Morgan WJ, Crain EF, Gruchalla RS, O'Connor GT, Kattan M, Evans R 3rd, et al. Results of a home-based environmental intervention among urban children with asthma. *N Engl J Med* 2004;351:1068–80.
  76. Szefer SJ, Mitchell H, Sorkness CA, Gergen PJ, O'Connor GT, Morgan WJ, et al. Management of asthma based on exhaled nitric oxide in addition to guideline-based treatment for inner-city adolescents and young adults: a randomized controlled trial. *Lancet* 2008;372:1065–72.
  77. Busse WW, Morgan WJ, Gergen PJ, Mitchell HE, Gern JE, Liu AH, et al. Randomized trial of omalizumab (anti-IgE) for asthma in inner-city children. *N Engl J Med* 2011;364:1005–15.
  78. Covar RA, Szefer SJ, Zeiger RS, Sorkness CA, Moss M, Mauger DT, et al. Factors associated with asthma exacerbations during a long-term clinical trial of controller medications in children. *J Allergy Clin Immunol* 2008;122:741–7 e4.
  79. Zorc JJ, Chew A, Allen JL, Shaw K. Beliefs and barriers to follow-up after an emergency department asthma visit: a randomized trial. *Pediatrics* 2009;124:1135–42.
  80. Teach SJ, Crain EF, Quint DM, Hylan ML, Joseph JG. Improved asthma outcomes in a high-morbidity pediatric population: results of an emergency department-based randomized clinical trial. *Arch Pediatr Adolesc Med* 2006;160:535–41.
  81. Boyd M, Lasserson TJ, McKean MC, Gibson PG, Ducharme FM, Haby M. Interventions for educating children who are at risk of asthma-related emergency department attendance. *Cochrane Database Syst Rev* 2009;2:CD001290.
  82. Schatz M, Kazzi AA, Brenner B, Camargo CA Jr, Corbridge T, Krishnan JA, et al. Joint task force report: supplemental recommendations for the management and follow-up of asthma exacerbations. Introduction. *J Allergy Clin Immunol* 2009;124(Suppl. 2):S1–4.
  83. Bruzzese JM, Evans D, Kattan M. School-based asthma programs. *J Allergy Clin Immunol* 2009;124:195–200.
  84. Gerald LB, McClure LA, Mangan JM, Harrington KE, Gibson L, Erwin S, et al. Increasing adherence to inhaled steroid therapy among schoolchildren: randomized, controlled trial of school-based supervised asthma therapy. *Pediatrics* 2009;123:466–74.
  85. Halterman JS, Szilagyi PG, Fisher SG, Fagnano M, Tremblay P, Conn KM, et al. Randomized controlled trial to improve care for urban children with asthma: results of the School-Based Asthma Therapy trial. *Arch Pediatr Adolesc Med* 2011;165:262–8.
  86. Evans D, Clark NM, Feldman CH, Rips J, Kaplan D, Levison MJ, et al. A school health education program for children with asthma aged 8–11 years. *Health Educ Q* 1987;14:267–79.
  87. Bruzzese JM, Sheares BJ, Vincent EJ, Du Y, Sadeghi H, Levison MJ, et al. Effects of a school-based intervention for urban adolescents with asthma. A controlled trial. *Am J Respir Crit Care Med* 2011;183:998–1006.
  88. Scott L, Morpew T, Bollinger ME, Samuelson S, Galant S, Clement L, et al. Achieving and maintaining asthma control in inner-city children. *J Allergy Clin Immunol* 2011;128:56–63.
  89. Okelo SO, Butz AM, Sharma R, Diette GB, Pitts SI, King TM, et al. Interventions to modify health care provider adherence to asthma guidelines: a systematic review. *Pediatrics* 2013;132:517–34.
  90. Evans D, Mellins R, Lobach K, Ramos-Bonoan C, Pinkett-Heller M, Wiesemann S, et al. Improving care for minority children with asthma: professional education in public health clinics. *Pediatrics* 1997;99:157–64.
  91. Cloutier MM, Wakefield DB, Carlisle PS, Bailit HL, Hall CB. The effect of Easy Breathing on asthma management and knowledge. *Arch Pediatr Adolesc Med* 2002;156:1045–51.
  92. Kattan M, Crain EF, Steinbach S, Visness CM, Walter M, Stout JW, et al. A randomized



- clinical trial of clinician feedback to improve quality of care for inner-city children with asthma. *Pediatrics* 2006;117:e1095–103.
93. Shapiro GG, Wightton TG, Chinn T, Zuckerman J, Eliassen AH, Picciano JF, et al. House dust mite avoidance for children with asthma in homes of low-income families. *J Allergy Clin Immunol* 1999;103:1069–74.
  94. Eggleston PA. Cockroach allergen abatement: the good, the bad, and the ugly. *J Allergy Clin Immunol* 2003;112:265–7.
  95. Arbes SJ Jr, Sever M, Mehta J, Gore JC, Schal C, Vaughn B, et al. Abatement of cockroach allergens (Bla g 1 and Bla g 2) in low-income, urban housing: month 12 continuation results. *J Allergy Clin Immunol* 2004;113:109–14.
  96. Sever ML, Arbes SJ Jr, Gore JC, Santangelo RG, Vaughn B, Mitchell H, et al. Cockroach allergen reduction by cockroach control alone in low-income urban homes: a randomized control trial. *J Allergy Clin Immunol* 2007;120:849–55.
  97. Krieger JW, Takaro TK, Song L, Weaver M. The Seattle-King County Healthy Homes Project: a randomized, controlled trial of a community health worker intervention to decrease exposure to indoor asthma triggers. *Am J Public Health* 2005;95:652–9.
  98. Butz AM, Matsui EC, Breyse P, Curtin-Brosnan J, Eggleston P, Diette G, et al. A randomized trial of air cleaners and a health coach to improve indoor air quality for inner-city children with asthma and secondhand smoke exposure. *Arch Pediatr Adolesc Med* 2011;165:741–8.
  99. Crain EF, Walter M, O'Connor GT, Mitchell H, Gruchalla RS, Kattan M, et al. Home and allergic characteristics of children with asthma in seven U.S. urban communities and design of an environmental intervention: the Inner-City Asthma Study. *Environ Health Perspect* 2002;110:939–45.
  100. Kattan M, Stearns SC, Crain EF, Stout JW, Gergen PJ, Evans R 3rd, et al. Cost-effectiveness of a home-based environmental intervention for inner-city children with asthma. *J Allergy Clin Immunol* 2005;116:1058–63.
  101. Carter MC, Perzanowski MS, Raymond A, Platts-Mills TA. Home intervention in the treatment of asthma among inner-city children. *J Allergy Clin Immunol* 2001;108:732–7.
  102. Homer C, Susskind O, Alpert HR, Owusu M, Schneider L, Rappaport LA, et al. An evaluation of an innovative multimedia educational software program for asthma management: report of a randomized, controlled trial. *Pediatrics* 2000;106(1 Pt 2):210–15.
  103. Huss K, Winkelstein M, Nanda J, Naumann PL, Sloand ED, Huss RW. Computer game for inner-city children does not improve asthma outcomes. *J Pediatr Health Care* 2003;17:72–8.
  104. Shegog R, Bartholomew LK, Parcel GS, Sockrider MM, Masse L, Abramson SL. Impact of a computer-assisted education program on factors related to asthma self-management behavior. *J Amer Med Inform Assoc* 2001;8:49–61.
  105. Stockwell MS, Kharbanda EO, Martinez RA, Vargas CY, Vawdrey DK, Camargo S. Effect of a text messaging intervention on influenza vaccination in an urban, low-income pediatric and adolescent population: a randomized controlled trial. *JAMA* 2012;307:1702–8.
  106. Szilagyi PG, Adams WG. Text messaging: a new tool for improving preventive services. *JAMA* 2012;307:1748–9.
  107. Redline S, Wright EC, Kattan M, Kerckmar C, Weiss K. Short-term compliance with peak flow monitoring: results from a study of inner city children with asthma. *Pediatr Pulmonol* 1996;21:203–10.
  108. Evans R 3rd, Gergen PJ, Mitchell H, Kattan M, Kerckmar C, Crain E, et al. A randomized clinical trial to reduce asthma morbidity among inner-city children: results of the National Cooperative Inner-City Asthma Study. *J Pediatr* 1999;135:332–8.
  109. Canino G, Vila D, Normand SL, Acosta-Perez E, Ramirez R, Garcia P, et al. Reducing asthma health disparities in poor Puerto Rican children: the effectiveness of a culturally tailored family intervention. *J Allergy Clin Immunol* 2008;121:665–70.
  110. Otsuki M, Eakin MN, Rand CS, Butz AM, Hsu VD, Zuckerman IH, et al. Adherence feedback to improve asthma outcomes among inner-city children: a randomized trial. *Pediatrics* 2009;124:1513–21.
  111. Madge P, McColl J, Paton J. Impact of a nurse-led home management training programme in children admitted to hospital with acute asthma: a randomised controlled study. *Thorax* 1997;52:223–8.
  112. Bailey EJ, Cates CJ, Kruske SG, Morris PS, Chang AB, Brown N. Culture-specific programs for children and adults from minority groups who have asthma. *Cochrane Database Syst Rev* 2009;1:CD006580.
  113. Fisher EB, Strunk RC, Highstein GR, Kelley-Sykes R, Tarr KL, Trinkaus K, et al. A randomized controlled evaluation of the effect of community health workers on hospitalization for asthma: the asthma coach. *Arch Pediatr Adolesc Med* 2009;163:225–32.
  114. Nelson KA, Highstein GR, Garbutt J, Trinkaus K, Fisher EB, Smith SR, et al. A randomized controlled trial of parental asthma coaching to improve outcomes among urban minority children. *Arch Pediatr Adolesc Med* 2011;165:520–6.
  115. Walders N, Kerckmar C, Schluchter M, Redline S, Kirchner HL, Drotar D. An interdisciplinary intervention for undertreated pediatric asthma. *Chest* 2006;129:292–9.
  116. Fisher EB, Strunk RC, Sussman LK, Sykes RK, Walker MS. Community organization to reduce the need for acute care for asthma among African American children in low-income neighborhoods: the Neighborhood Asthma Coalition. *Pediatrics* 2004;114:116–23.
  117. Clark NM, Lachance LL, Benedict MB, Doctor LJ, Gilmore L, Kelly CS, et al. Improvements in health care use associated with community coalitions: long-term results of the allies against asthma initiative. *Am J Pub Health* 2013;103:1124–7.
  118. Wood P, Tumieli-Berhalter L, Owen S, Taylor K, Kattan M. Implementation of an asthma intervention in the inner city. *Ann Allergy Asthma Immunol* 2006;97(1 Suppl. 1):S20–4.
  119. Lara M, Bryant-Stephens T, Damitz M, Findley S, Gavillan JG, Mitchell H, et al. Balancing 'fidelity' and community context in the adaptation of asthma evidence-based interventions in the 'real world'. *Health Promot Pract* 2011;12(6 Suppl. 1):63S–72S.
  120. Kattan M. Moving research into the community: learning by experience. *Ann Allergy Asthma Immunol* 2006;97(1 Suppl. 1):S2–3.

# Asthma in Older Children: Special Considerations

LEONARD B. BACHARIER | ROBERT C. STRUNK

## KEY POINTS

- Failure of symptoms to respond to  $\beta$ -agonists and oral steroids should prompt consideration that the symptoms are not caused by asthma but by another process.
- Cough that persists despite treatment with bronchodilators and systemic corticosteroids is often not due to asthma. Consideration of other disorders, particularly sinusitis, is imperative.
- The Asthma Action Plan is the centerpiece of asthma education, focusing the child and parents on early warning signs, when to increase treatment and when to call for advice during more severe exacerbations. The action plan is directly relevant, focussing on action not theory. An understanding of theory may be helpful when the family can focus on these details.
- Pulmonary function measures may not accurately reflect asthma severity in children, who can have an FEV<sub>1</sub> in the normal range even when disease is severe. The FEV<sub>1</sub>/FVC ratio is a much better indicator of severity of disease.
- Asthma is controllable in the vast majority of children. Even children with severe asthma can be expected fully to participate in activities. This is an important goal for children and their parents.

Asthma is the most common chronic disorder of childhood, affecting approximately 10.7% of children aged 5 to 14 years,<sup>1,2</sup> with 6.4% of children in this age group reporting an episode of asthma or an asthma attack in the preceding 12 months.<sup>1,2</sup> However, estimates of wheezing in this age group approach 20% or greater in some areas of the USA and in many industrialized countries, further magnifying the impact of wheezing disease on children.

## Epidemiology and Etiology

### PREVALENCE OF CHILDHOOD ASTHMA

In the USA from 1980 to 2010 asthma prevalence in the general population increased from 3.1% to 8.4%, with increases among 5- to 14-year-old children from 4.4% in 1980 to 8.2% in 1995, 9.1% in 2004, and 10.7% in 2010.<sup>1,2</sup> Although the rise in asthma prevalence may reflect coding and classification issues, the influence of other factors, such as environmental exposures to allergens, infectious agents, endotoxin, vitamin D insufficiency and tobacco smoke, must also be considered. Place of residence appears to influence asthma prevalence.<sup>3</sup> Furthermore, there

appears to be an effect of gender on asthma prevalence, as the male-to-female ratio for asthma is 1.8:1 among children aged 2 years and under, but by puberty, asthma becomes more prevalent amongst females (M:F ratio of 0.8:1). The change in gender ratio represents development of new cases of asthma in females during adolescence, not a decrease in males with asthma.<sup>4</sup>

### FACTORS INFLUENCING THE ETIOLOGY OF ASTHMA

A general pattern of factors influencing development of asthma seems to be emerging, including family history/genetics, smoking, diet, obesity and inactivity, all of which seem to influence the development of asthma and disease outcomes (Table 34-1).

#### *Socioeconomic Status*

Many clinical or area studies have reported substantially higher rates of asthma prevalence, morbidity, hospitalization and mortality among racial and ethnic minorities. However, asthma is also most common among low socioeconomic groups regardless of race. While black children have higher rates of asthma than white children, most studies have found that black race is not a significant correlate of asthma after controlling for location of residence and socioeconomic status (SES). The basis for the effects of poverty and urban residence on asthma prevalence is not known. One potential factor is exposure and sensitization to allergens common in urban environments. Black children in inner city Atlanta are exposed to high levels of dust mite and cockroach allergen, and a high proportion of the children with asthma was sensitized to these allergens.<sup>5</sup> Litonjua et al also concluded that a large proportion of the racial/ethnic differences in asthma prevalence can be explained by factors related to income, area of residence and level of education.<sup>6</sup>

Income is a determinant of access to health care and frequently the quantity and quality of health care available. Persons who have low income, regardless of race or ethnicity, are more likely to be under- or uninsured, to encounter delays in receiving or be denied care, to rely on hospital clinics in emergency departments for health services and to receive substandard care. The usual socioeconomic indicators, education and personal or household income, serve only as surrogates for more complicated correlates of individuals within populations and multiple factors that can impact both on prevalence of asthma and adverse outcomes from the disease.

#### *Genetics*

The genetic basis of heritability has been extensively studied and while the genetic basis of asthma remains incompletely understood, studies are yielding some understanding<sup>7,8</sup> (see

**TABLE 34-1** Factors which Influence Disease Development and Severity

Factor	Disease Development	Disease Severity
Atopy	++++	++++
Allergen exposure	++	++++
Rhinitis	++	++
Sinusitis	?	+++
Infection (viral)	+	++++
Gastroesophageal reflux	–	++
Environmental factors		
Intrauterine tobacco smoke	++	?
Passive tobacco smoke	+	++
Air pollution	–	++
Psychological factors (including stress)	+	++++
Socioeconomic status	++	++++
Adherence	–	++++
Obesity	Adolescent females	++
Diet	?	?
Exercise	?	++*
Drugs (including ASA/NSAIDs)	–	++†

\*While exercise is a common precipitant of asthma symptoms, improved physical conditioning can reduce asthma severity.

†Consider in the context of asthma, nasal polyposis and severe sinus disease.

Chapter 3). There is as of yet no established genetic pattern that predicts presence of asthma or defines its severity.

### Allergy

Studies of school children in Melbourne, Australia by Williams and McNicol<sup>9</sup> have indicated increases in both the incidence of asthma and asthma severity with increases in number of positive skin tests and total serum IgE. The relationship between allergy and asthma has more recently been highlighted by the importance of aeroallergen sensitivity in the progression of frequent intermittent wheezing to persistent asthma in young children.<sup>10</sup> Several large epidemiological studies have clearly indicated the importance of aeroallergen sensitization in asthma development among populations at risk. Sensitization to house dust mite and mold was a predictor of asthma in rural Chinese individuals selected on the basis of having at least two siblings with physician-diagnosed asthma.<sup>11</sup> In a similar study, total serum IgE levels and positive skin tests to aeroallergens were correlated with current wheezing.<sup>12</sup> This association was present in children from nonatopic, asymptomatic probands, as well as in the expected atopic asthmatic probands, suggesting that much of the increase in asthma prevalence is associated with specific IgE sensitization and is occurring in persons previously considered to be at low risk for developing asthma or atopy.

### Demographic and Environmental Factors

Studies comparing the populations of East and West Germany showed the prevalence of hay fever and asthma to be significantly higher in West German children, suggesting that environmental factors may explain the difference in prevalence in these ethnically similar populations.<sup>13</sup> Early exposure to infections (e.g. being in a daycare environment early in life) or

exposure to endotoxin or other bacterial products (e.g. growing up on a farm with close exposure to the farm animals) is associated with a decreased prevalence of asthma. In contrast, growing up in an urban environment or generally with an increased standard of living is associated with an increased prevalence of asthma.<sup>14</sup> Such correlates are also present for atopic diseases other than asthma. In fact, Strachan, who noted that prevalence of hay fever was inversely related to family size, was the first to recognize the importance of early exposures on atopic disease.<sup>15</sup> In the USA, asthma is more prevalent in African-Americans and Puerto Ricans. These findings are not explained by the observations on the role of social class in European studies. Given the ethnic differences between African-Americans and whites, these studies may represent gene-environment interaction producing varied phenotypic outcomes.

### Gene-Environment Interaction

Genetic factors alone cannot explain the rise in asthma prevalence, morbidity or mortality.<sup>16</sup> However, a small change in the prevalence of relevant environmental exposures could explain a significant rise in disease prevalence among genetically susceptible individuals. Gene-environment interaction, defined as the co-participation of genetic and environmental factors, is particularly relevant to the etiology of asthma morbidity, particularly in individuals who experience a disproportionate burden of environmental exposures,<sup>17</sup> and may exert its effect through epigenetic mechanisms.<sup>18</sup> Relevant exposures include smoking, stress, nutritional factors, infections, allergens and occupational exposures. In addition, racial/ethnic variability in the distribution of genetic polymorphisms can potentially modify the response to pharmacotherapeutic agents, such as the  $\beta_2$ -adrenergic agonists.<sup>19</sup>

### Stress

Negative family characteristics such as family conflict and family dysfunction discriminated children who died of asthma from children with equally severe asthma who did not die.<sup>20</sup> Parenting difficulties have been associated with a higher risk for the development of asthma early in life.<sup>21</sup> In addition, children with the highest risk of developing early-onset asthma were those in families with both parenting problems and high stress. Evidence for a link between stress and asthma has been gained from temporal studies, as experiencing an acute negative life event increased children's risk for an asthma attack 4 to 6 weeks after the occurrence of the event.<sup>22</sup> Moreover, the combination of chronic and acute stress plays a role in the temporal association. Experiencing an acute life event among children who had ongoing chronic stress in their lives shortened the time frame in which they were at risk for an asthma attack to within 2 weeks of the acute event. The experience of daily life stressors is associated with same-day lower peak expiratory flow (PEF) rate and greater self-report of asthma symptoms. Further, high levels of stress have been associated with detrimental biological profiles, such as greater inflammatory responses after antigen challenge or in vitro stimulation of immune cells among children with or at risk for asthma.<sup>23,24</sup>

Children with asthma have been found to have higher rates of clinically significant family stress compared with healthy children.<sup>25</sup> Children whose families are more cohesive are more likely to have controlled, rather than uncontrolled, asthma.<sup>26</sup> Additionally, parenting difficulties early in a child's life, particularly during times of high stress, have been found to predict the

onset of asthma in childhood.<sup>21</sup> Thus, strain in the family, both in terms of conflicts among family members and impact of illness on family relationships, could be associated with both increased asthma prevalence and poor asthma outcomes.

One psychological pathway that has been suggested to explain associations of SES with asthma is the differential experiences of stress faced by children of low and high SES. In healthy children, low SES has been associated with more frequent exposure to stressful life events, and children who live in low SES neighborhoods are more likely to report witnessing incidences of violence. Low SES also has been associated with more negative stress appraisals.<sup>27</sup>

### Obesity

Obesity is linked with the development and severity of asthma in both children and adults, and weight reduction improves asthma severity and symptoms.<sup>28,29</sup> Similar to the results in industrialized countries, Celedon and colleagues found an association between overweight and presence of asthma or airway hyperresponsiveness among adults in China with either physician-diagnosed asthma or airway responsiveness to methacholine.<sup>30</sup> They also found an association between underweight (body mass index [BMI] 16 kg/m<sup>2</sup> or less) and asthma, which could be the result of an effect of asthma symptoms on nutrition or an effect of previous weight loss and development of asthma.

The relationship between obesity and asthma observed in adults has also been most often observed in adolescent females, but not in males. Girls who were overweight or obese at age 11 years were more likely to have current wheezing at ages 11 and 15 years, but not at ages 6 to 8 years. The relationship between obesity and asthma is strongest among females beginning puberty before age 11 years. Females who become overweight or obese between 6 and 11 years are seven times more likely to develop new asthma symptoms at age 11 and 13 years.<sup>31</sup> The mechanism of increased asthma with obesity is not clear. The strong gender differences observed<sup>31,32</sup> suggest that overweight status itself does not produce the asthma, as a direct effect of weight is not seen in both boys and girls. Longitudinal studies<sup>31</sup> suggest that there is a more fundamental relationship, as most of the asthma in obese adolescent girls was new-onset asthma. In a study of young adults with asthma,<sup>33</sup> a lower level of physical activity did not explain the association between the incidence of asthma and gain in weight. Poor asthma control in obese children with asthma may be overestimated since obesity is associated with enhanced perception of nonspecific symptoms such as dyspnea that results from altered mechanical properties of the chest wall.<sup>34</sup>

### Infection

Viral respiratory infections are present in up to 85% of children with exacerbated asthma.<sup>35</sup> In addition to worsening asthma, there may be a more fundamental relationship between infection and the development of asthma. Such a relationship has been suggested by the finding of a higher than expected incidence of bronchial hyperresponsiveness in children who had whooping cough, croup or bronchiolitis in their early years of life.<sup>36</sup> Children hospitalized with respiratory syncytial virus bronchiolitis are at increased risk for asthma at school age,<sup>37–39</sup> and this risk appears to persist to early adulthood.<sup>40</sup> In addition, wheezing in the context of rhinovirus infection during the preschool years is also a significant risk factor for asthma at school age.<sup>41</sup>

The role of *Mycoplasma pneumoniae* or *Chlamydia pneumoniae* infections in the underlying pathogenesis of asthma has been suggested (see Chapter 31). A conclusive association between development of *C. pneumoniae* or *M. pneumoniae* infection and onset of asthma, or even an association between the presence of the organism and more severe disease, remains to be established in large prospective studies.

### Diet

Several studies have identified relationships between maternal and infant diets and subsequent asthma risk.<sup>42</sup> Studies in birth cohorts have found that higher maternal intakes of vitamin D during pregnancy from both foods and supplements were associated with an almost 60% reduction of asthma and recurrent wheezing in 3- to 5-year-old children.<sup>43,44</sup> Other studies identified a relationship between a high dietary intake of vitamins C, A, and E with higher levels of lung function. A longitudinal analysis of decline in forced expiratory volume in 1 second (FEV<sub>1</sub>) over a 9-year period in adults found the decline to be lower amongst those with a higher average vitamin C intake, but no relationship to magnesium or vitamins A or E.<sup>45</sup> The relationship between diet and atopy is not clearly understood, although there is some evidence for a relationship between concentrations of vitamin E and both allergen skin sensitization and IgE concentrations.<sup>46</sup>

## Natural History of Asthma

### PERSISTENCE AND PROGRESSION OF DISEASE INTO ADULTHOOD

The course of asthma through childhood and adolescence is variable. More severe asthma is likely to persist from childhood into adulthood without remission, with only 15% of children with severe asthma experiencing remission by age 50 years.<sup>47</sup> Another important tendency in the natural history is for symptoms to remit in adolescence only to return again in adulthood. In general, the amount of wheezing in early adolescence seems to be a guide for severity in early adult years, with 73% of those with few symptoms at age 14 years continuing to have little or no asthma at age 28 years.<sup>48</sup> Similarly, 68% of those with frequent wheezing at 14 years still experienced recurrent asthma at age 28 years. Most subjects with frequent wheezing at 21 years continued to have comparable asthma at 28 and 50 years. In addition to the importance of symptoms, the childhood degree of bronchial responsiveness combined with a low FEV<sub>1</sub> was also related to the outcome of asthma in adulthood.<sup>49</sup> While many children become asymptomatic in adolescence, pulmonary function deficits associated with asthma and wheeze increase throughout childhood,<sup>50</sup> and a significant proportion of children free of symptoms and with normal FEV<sub>1</sub> and even FEV<sub>1</sub>/forced vital capacity (FVC) ratios, continue to have increases in bronchial reactivity.<sup>51</sup> This bronchial hyperresponsiveness is an independent risk factor for development of a low FEV<sub>1</sub> and associated symptoms in early adulthood.<sup>52</sup> What is perhaps most concerning about the persistence of childhood disease into adulthood is the development of chronic airflow obstruction, with loss of bronchodilator responsiveness<sup>53</sup> and a decline in FEV<sub>1</sub> over time, that is greater in adults with asthma than in asymptomatic peers.<sup>54</sup> These findings suggest that asthma, even uncomplicated by cigarette smoking, may be a precursor of a chronic obstructive pulmonary disease (COPD)-like syndrome in adults.



## DURATION OF DISEASE IS ASSOCIATED WITH DEGREE OF ABNORMALITY IN PULMONARY FUNCTION

Longer duration of asthma was associated with lower levels of lung function in children with mild-to-moderate asthma aged 5 to 12 years.<sup>55</sup> This association was independent of levels of atopy, presence of household allergens and prior use of anti-inflammatory medications. Duration of asthma was associated with lower levels of both pre- and post-bronchodilator values for FEV<sub>1</sub> and FEV<sub>1</sub>/FVC ratio.<sup>55</sup> While the values for FEV<sub>1</sub> both pre- and post-bronchodilation were well within the normal range for children (93.9% predicted and 102.8% predicted, respectively), more than 50% of children with asthma had low FEV<sub>1</sub>/FVC ratios, suggesting that airway obstruction is present and worsens even with relatively mild-to-moderate asthma. The degree of bronchial hyperresponsiveness in these children was also related to the duration of disease.<sup>56</sup> Since level of pulmonary function and degree of bronchial hyperresponsiveness are independent predictors of abnormal levels of lung function in adults who had childhood asthma, it is apparent that longer duration of disease in childhood and its associated abnormalities of lung function predispose adults to disease.

## Morbidity and Mortality

In 2010, 6.4% of US children experienced a self-reported asthma attack, with no significant decrease in incidence since 1997<sup>1,2</sup> in spite of the much improved therapies available. Between 2001 and 2009, the rate of outpatient office visits remained relatively stable at 351 visits/10,000 population/year.<sup>1,2</sup>

Emergency department visits among children aged 5 to 14 years increased by approximately 8% from 2001 to 2009, with nearly 10% of children aged 5 to 14 years seeking emergency department care yearly.<sup>12</sup> Rates among blacks are almost 3-fold higher than rates for whites. Asthma is the leading admitting diagnosis to children's hospitals,<sup>2</sup> and blacks have greater than 3-fold more hospitalizations than whites. Rates of hospitalizations in 5- to 14-year-old children remained stable from 1980 to 2009, and were more than 3-fold lower than for younger children. A significant proportion of hospitalizations are repeat hospitalizations, with rehospitalizations accounting for 20% to 25% of hospitalizations in a signal year and up to 43% of hospitalizations in one urban children's hospital within a 5- to 10-year period.<sup>57</sup> A lifetime history of hospitalizations was associated with family impacts (greater family strain and family conflict, greater financial strain), as well as caregiver characteristics of greater personal strain and beliefs about not being able to manage one's child's asthma.<sup>58</sup> Individual characteristics of the caregiver (lower sense of mastery, being less emotionally concerned by asthma) predicted greater likelihood of future asthma hospitalizations.<sup>58</sup>

The rate of deaths due to asthma in 5- to 14-year-old children increased more than 2-fold from 1980 (1.8 per million) to 1995 (3.4 per million) before stabilizing through 2002 (2.4 per million) and then increasing in 2004 to 2.6 per million and 2.8 per million in 2009.<sup>1,2</sup> Blacks have many more deaths from asthma than whites (2.9-fold in 2009). While the death rate in children is relatively small compared to that in other age groups, physicians find that many, if not most, of these deaths are preventable, with the major reason for death being late arrival to health care associated with poor use of oral corticosteroids. Late

arrival is often associated with psychological problems in the family or child, but can be associated with shortcomings in availability of medical care.

While there have been significant efforts toward understanding the reasons for the occurrence of fatal and near-fatal asthma episodes, the identification of patients at risk for dying remains an art with no single set of criteria able to identify all patients who will die. Prior history of severe events, especially respiratory failure requiring intubation, is an obvious risk factor. However, while as many as 25% of patients with a history of respiratory failure die in a 3- to 5-year follow-up, most patients who die have not had a previous episode of respiratory failure.<sup>59</sup> Most studies indicate that a high proportion of patients who have died have had severe asthma, but the number of patients with severe disease is large and only 1% to 3% will die over an extended follow-up period. The importance of psychological factors in poor outcomes from asthma<sup>20</sup> indicates that patient and family factors resulting in psychological dysfunction need to be identified as well.

There are certain time intervals when risk of fatality is increased. For example, patients may need extra care and communication in periods following hospitalization, as enhanced bronchial hyperresponsiveness persists after hospitalization much longer than abnormalities in spirometry, and oral steroids will be being weaned, further increasing risk. Hospitalizations that occur in spite of optimally prescribed therapy are of special concern.

## Differential Diagnosis of Asthma

The differential diagnosis of cough and wheeze is extensively reviewed in Chapters 27, 32, and 37.

## Evaluation

Figure 34-1 presents an algorithm for evaluation of a school-age child or adolescent who presents with chest symptoms of cough, wheeze, shortness of breath, chest tightness or chest pain.

## HISTORY

Historical elements should include specific symptoms, their frequency and severity, triggering factors and response to therapy. Age of onset of symptoms is important, as 80% of patients with asthma experience symptoms within the first 5 years of life. Thus, the adolescent presenting with recent onset of symptoms without a prior history warrants further evaluation of alternative diagnoses. Since asthma is a disorder characterized by repeated episodes of at least partially reversible airflow obstruction, failure of symptoms to improve with treatment including bronchodilators and corticosteroids should prompt evaluation for other processes, either a nonasthma diagnosis or a co-morbid condition complicating underlying asthma.

A short series of questions focussing on recent symptom frequency is extremely informative in assessing the child with asthma. The Asthma Control Test (ACT) serves this purpose,<sup>60,61</sup> and when completed at each follow-up asthma visit, can serve as a rapid appraisal of asthma control over time.

Additional history should focus on identification of other co-morbid conditions that may worsen asthma severity, including allergen exposure, rhinitis, sinusitis and gastroesophageal reflux. Furthermore, an assessment of underlying psychosocial

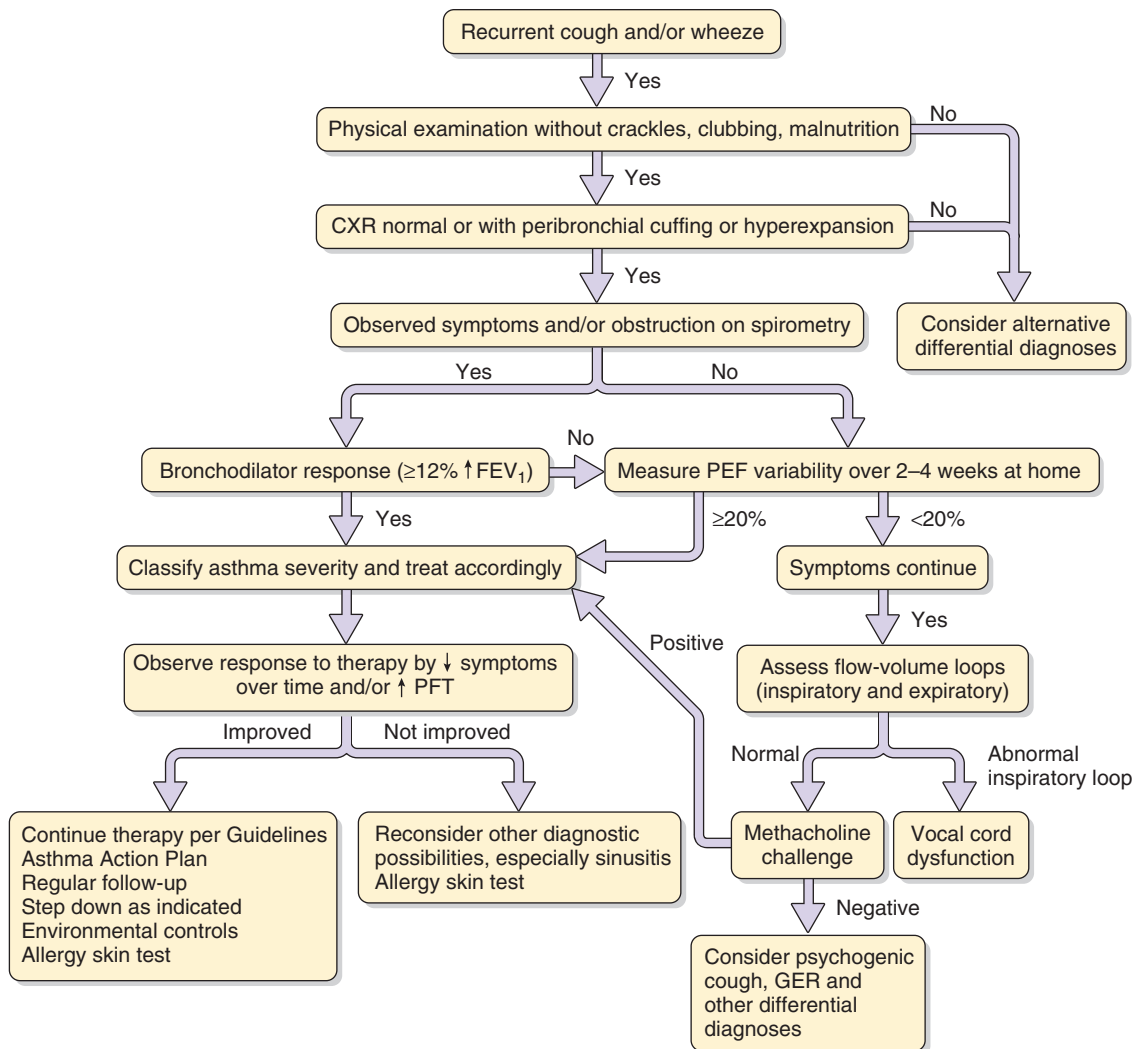

**Figure 34-1** Algorithm for establishing diagnosis in children with recurrent cough and wheeze. CXR – chest x-ray, FEV<sub>1</sub> –forced expiratory volume in 1 second, PEF – peak expiratory flow, PFT – pulmonary function test, GER – gastroesophageal reflux.

factors and adherence to the medical regimen may provide valuable clues as to barriers in delivery and receipt of asthma care.

## PHYSICAL EXAMINATION

Findings may include an increased anteroposterior chest diameter in severe disease and expiratory wheezes and prolongation of the expiratory phase during exacerbation. Presence of nasal polyposis should prompt an evaluation for cystic fibrosis, regardless of the age of the child, as cystic fibrosis remains the leading cause of polyps in childhood. The primary focus of the exam should include careful evaluation to assure absence of findings suggestive of other diseases, such as the presence of crackles, digital clubbing and hypoxemia, as well as to uncover factors that worsen disease, including nasal and sinus disease.

## LABORATORY EVALUATION

Peripheral blood eosinophilia and/or elevated serum IgE levels are often found in children with asthma and can be helpful in the evaluation of severe disease. Laboratory evaluation is helpful

in excluding entities that comprise the differential diagnosis of asthma. Serum immunoglobulin levels (IgG, IgM and IgA) may be helpful in evaluating for defects in humoral immunity predisposing to recurrent lower respiratory tract illness. Sweat chloride analysis is required to exclude cystic fibrosis. Children with bronchiectasis along with chronic otitis media and sinusitis may warrant an evaluation of ciliary structure and function. A purified protein derivative (PPD) skin test is helpful in excluding mycobacterial infection.

## ASSESSMENT FOR ALLERGIC SENSITIZATION

Evaluation for allergen-specific IgE, either by percutaneous skin testing or in vitro testing, should be part of the evaluation of all children with persistent asthma, as proper identification of allergic sensitivities and instruction in environmental control measures may provide significant clinical benefit.

## RADIOLOGY

All children with recurrent episodes of cough and/or wheeze should have a chest radiograph (anteroposterior and lateral

views) to aid in exclusion of other diagnostic entities. Radiographic findings that may be seen with asthma include hyperexpansion, increased anteroposterior diameter, peribronchial cuffing and/or areas of atelectasis (any lobe or subsegment can be involved). Findings of chronic changes, including bronchiectasis, should lead to further evaluation of alternate diagnoses.

### PULMONARY FUNCTION TESTS

With the help of well-trained and experienced pulmonary function technicians, children as young as 4 to 5 years of age should be capable of performing spirometry. Spirometry measures FVC, FEV<sub>1</sub>, the ratio of FEV<sub>1</sub>/FVC, as well as other measures of airflow including the forced expiratory flow between 25% and 75% of FVC (FEF<sub>25-75</sub>). The FEV<sub>1</sub> is the most commonly used and reproducible measure of pulmonary function, whereas the FEF<sub>25-75</sub> demonstrates much more inpatient variability. Standards are widely available for most spirometric measures and allow for correction for patient age, gender, race and height. The FEV<sub>1</sub>/FVC ratio is an indicator of airflow obstruction and may be more sensitive in identifying airflow abnormalities in asthma than the FEV<sub>1</sub>, as most children with asthma have an FEV<sub>1</sub> within the normal range, even in the presence of severe disease (see section on Classification of asthma severity).

Asthma is characterized by airflow obstruction that is at least partially reversible by a bronchodilator. Thus, spirometry is often performed before and 20 minutes following administration of a bronchodilator such as albuterol. An increase in the FEV<sub>1</sub> of at least 12% is considered to represent a significant change and exceeds that seen in nonasthmatic individuals, although recent evidence suggests that lower levels of bronchodilator response ( $\geq 8-9\%$ ) may be more appropriate cut-offs in identifying asthma in children.<sup>62,63</sup>

Particular attention should be given to the inspiratory and expiratory flow-volume loops, as they are extremely helpful in excluding other patterns of airway obstruction.<sup>64,65</sup> For example, fixed airway obstruction (abnormalities on both the expiratory and inspiratory loops) can be seen with a mediastinal mass compressing a large airway or variable extrathoracic airway obstructive process (abnormalities just on the inspiratory loop) is seen with vocal cord dysfunction (VCD). Asthma produces variable intrathoracic obstruction (abnormalities on just the expiratory loop). Patients with VCD without asthma do not demonstrate intrathoracic airway obstruction, but may show blunting or truncation of the inspiratory loop consistent with variable extrathoracic obstruction. Variability between spirometric trials is not uncommon in patients with VCD, often consisting of normal and abnormal inspiratory loops during a single session.

In addition to spirometry, other tests of pulmonary function may aid in the evaluation of the child with asthma that is difficult to diagnose or control. Patients with asthma generally demonstrate normal total lung capacity (TLC) on lung volume testing by plethysmography, but may demonstrate evidence of air trapping as shown by elevated residual volumes (RV) and RV/TLC ratio. Measurement of diffusing capacity of carbon monoxide (DL<sub>CO</sub>) is normal in patients with asthma, and abnormalities in DL<sub>CO</sub> should prompt evaluation for interstitial lung diseases.

Fractional exhaled nitric oxide (FeNO) is a noninvasive marker related to asthmatic airway inflammation as reflected

by bronchial wall inflammation,<sup>66</sup> sputum eosinophilia<sup>67</sup> and airway hyperresponsiveness.<sup>68</sup> FeNO levels increase as asthma control deteriorates<sup>69</sup> and decrease with treatment with agents which reduce airway inflammation, including inhaled corticosteroids (ICSs)<sup>70-72</sup> and leukotriene receptor antagonists (LTRAs).<sup>73-75</sup>

### CHALLENGE TESTING

Some children present with atypical features of asthma and may pose greater challenges in confirming an asthma diagnosis. Thus, use of bronchial challenges with agents that provoke bronchoconstriction may be helpful in the diagnosis and management of the child with atypical symptoms, poor response to asthma medications or lack of a response to a bronchodilator during spirometry. Agents used for bronchoprovocation challenges include methacholine, mannitol, histamine, adenosine, allergen, cold air and exercise. Methacholine challenge has been widely used in epidemiological and clinical trials of childhood asthma and has demonstrated an excellent safety record. Challenge studies should be performed in laboratories familiar with such procedures.

### BRONCHOSCOPY

In children with particularly severe disease or with poor response to conventional therapy, direct visualization of the airways along with bronchoalveolar lavage (BAL) may provide important clinical information. Such examinations may reveal the presence of previously undiagnosed foreign body aspiration or other intrinsic airway mass, infection, extrinsic airway compression, evidence of chronic aspiration, as well as indicators of airway inflammation (such as eosinophilia or neutrophilia).

## Evaluation and Management of Factors which Increase the Severity of Disease

### OVERVIEW

The most common precipitating factors are respiratory infections and weather changes. Drawing attention to these factors can prompt patients to start increased treatment early in an exacerbation, as they will be looking for increasing symptoms that occur as an infection starts or as weather is changing rapidly. Exercise is also commonly identified as an exacerbating factor. Interestingly, although it is known that exposure to allergens and irritants can worsen asthma, such exposures are much less commonly recognized as important.

### EXPOSURE TO INHALANT ALLERGENS

Exposure and allergic sensitization to cockroach allergen was associated with a significantly greater risk of asthma hospitalization and greater healthcare utilization among 476 children aged 4 to 9 years who participated in the National Cooperative Inner-City Asthma Study.<sup>76</sup> Allergic sensitization to the mold *Alternaria* has been identified as a significant allergen in terms of increasing airway hyperresponsiveness<sup>77</sup> and was associated with a nearly 200-fold increased risk of respiratory arrest due to asthma,<sup>78</sup> emphasizing the importance of determining

underlying allergic sensitivities in patients with asthma and providing patients with accurate and practical advice on allergen avoidance techniques.

The Childhood Asthma Management Program, comprised of 1,041 children aged 5 to 12 with mild-to-moderate asthma, found that allergic sensitization to tree pollen, weed pollen, *Alternaria*, cat dander, dog dander or indoor molds was associated with greater airway hyperresponsiveness to methacholine, although only sensitivity to dog and cat dander and the outdoor fungus *Alternaria* had independently significant relationships.<sup>79</sup> A cross-sectional analysis of a birth cohort of 562 children studied at 11 years of age found that bronchial hyperresponsiveness significantly correlated with higher levels of total serum IgE.<sup>80</sup> Burrows and co-workers<sup>81</sup> found a close relationship between total serum IgE and both the severity and persistence of bronchial responsiveness in a longitudinal study of adolescents and adults. Together these findings further the importance of control of these allergens in attenuating asthma symptoms.

A number of studies have followed children with asthma through childhood and adolescence into adulthood. Conclusions from the study in Melbourne, Australia indicate that severity of asthma in adulthood is related to the presence of increased levels of atopy in childhood, with the presence of an atopic condition in childhood shifting the risk of asthma in later life toward more severe outcomes.<sup>9</sup>

There is a clear association between sensitization to pets and current wheezing and bronchial hyperresponsiveness.<sup>82</sup> Dharmage and co-workers found that a high level of cat allergen in floor dust was associated both with an increased risk of being sensitized to cats and the presence of current asthma.<sup>82</sup> In the Childhood Asthma Management Program (CAMP) population, children sensitized to dog and exposed to high levels of dog allergen and sensitized to cat and exposed to high levels of cat allergen had a clearly increased risk of nocturnal awakenings.<sup>83</sup>

In contrast, there is evidence of a lower risk of asthma among children exposed to pets in early life compared with unexposed children.<sup>84</sup> Other studies find that individuals living with a pet have significantly less asthma or less severe bronchial hyperresponsiveness.<sup>85</sup> Studies showing protection from pet ownership are confounded by the likelihood that subjects with less severe asthma can keep the pets, whereas subjects with more severe disease are unable to hold pets.

## RHINITIS

Rhinitis is common in children with asthma, with estimates of up to 80% of patients with asthma reporting upper airway symptoms. Whereas most rhinitis that worsens asthma is allergic, perennial rhinitis in nonatopic subjects can be a risk factor for more severe asthma.<sup>86</sup> Topical nasal steroid therapy for allergic rhinitis has also been shown to attenuate the increase in bronchial hyperresponsiveness during the grass pollen season,<sup>87</sup> as well as decrease the risk of emergency department visits<sup>88</sup> or hospitalizations for asthma.<sup>89</sup> Thus, treatment plans for patients with asthma and allergic rhinitis should consist of optimal management of concomitant allergic rhinitis (see Chapter 24).

## SINUSITIS

Sinusitis is often discovered in the search for factors responsible for an overall worsening of asthma unexplained by changes of

environment or other obvious historical features. Although many patients present with symptoms of upper airway disease along with asthma, some have sinusitis as a significant contributor to difficult-to-control asthma but with a paucity of symptoms suggestive of sinusitis.

Radiographic examination of the paranasal sinuses in children hospitalized for acute asthma exacerbations is positive in 30% to 60% of children, partly depending upon the diagnostic technique used (Water's view radiograph or computed tomography of the sinuses). The effect of antibiotic treatment of bacterial sinusitis on asthma control has been examined in several clinical studies and shown to reduce asthma medication use, decrease asthma symptoms and improve bronchial hyperresponsiveness.<sup>90,91</sup> (see Chapter 26). Duration of antibiotic treatment should be individualized, but should continue until the patient is symptom-free for at least 7 days.

## GASTROESOPHAGEAL REFLUX

Gastroesophageal reflux (GER) is common among patients with asthma. In adults with asthma the estimated prevalence of GER approaching 80%.<sup>92</sup> Studies of the prevalence of GER in pediatric patients with asthma are limited, but a reported 64% incidence of a positive pH probe study in a group of 25 children with asthma<sup>93</sup> suggests that GER may also be common among children with asthma.

In our experience most young children and even adolescents with GER do not report symptoms classically associated with GER in adults, including heartburn, chest pain, dysphagia or hoarseness. In fact, children rarely complain of symptoms even in the presence of significant GER demonstrated by pH probe studies. Thus, a high level of suspicion of underlying GER is necessary in the evaluation of the child with severe asthma, especially uncontrolled asthma associated with nocturnal symptoms. However, a recent trial in children with persistent asthma without symptoms of GER did not demonstrate a benefit of gastric acid suppression with omeprazole in terms of asthma symptom control, even among children with evidence of GER by pH probe study.<sup>94</sup>

## ENVIRONMENTAL EXPOSURES (INCLUDING TOBACCO SMOKE)

Passive exposure to tobacco smoke is a clear exacerbating factor in asthma, with increases in asthma prevalence and asthma severity among children exposed to parental smoking.<sup>95</sup> Maternal smoking is associated with small but statistically significant, and probably clinically important, deficits in pulmonary function among school children. Since most smokers begin smoking during the adolescent years, active personal tobacco smoke exposure must be considered in all adolescents with asthma, especially when the clinical course becomes more severe. Cigarette smoking has been reported to be associated with mild airway obstruction and slowed growth of lung function in adolescents without asthma.<sup>96</sup> Furthermore, asthma has been linked to an accelerated rate of decline in FEV<sub>1</sub> over time, and this rate is even greater among asthmatic individuals who smoke.<sup>54</sup>

Many patients report that their asthma is triggered by 'weather changes.' Weather changes may be accompanied by changes in airborne allergen exposures. However, multiple studies have failed to find a definitive link between airborne



outdoor allergen levels (except for an occasional mold) and worsening asthma symptoms. Thus, the true link between weather changes and asthma attacks remains unknown. In addition to allergen exposure, epidemiological studies suggest an association between levels of air pollutants, including ozone, nitrogen oxides, carbon monoxide and sulfur dioxide, and symptoms or exacerbations of asthma.

### VOCAL CORD DYSFUNCTION

Vocal cord dysfunction (VCD), a functional respiratory tract disorder resulting from paradoxical adduction of the vocal cords, complicates the diagnosis and management of common respiratory tract problems, including asthma.<sup>97</sup> The recognition of VCD in a patient with atypical or difficult-to-control asthma is critical in minimizing symptoms and potential side-effects associated with treatment of severe asthma. The symptoms of VCD are not unique to the disorder and include cough, wheeze, stridor, dyspnea, hoarseness and choking. Some patients report difficulty swallowing or tightness in the chest or throat. Patients with VCD often report difficulty 'getting air in' due to paradoxical adduction of the vocal cords during inspiration, in contrast to difficulty with exhalation as reported by asthmatics. However, patients with significant exacerbation of asthma do have diffuse airway narrowing and can have significant inspiratory limitation, which can dominate their perception of breathing difficulties. Cough is a common feature of VCD and must be differentiated from cough due to asthma or from post-nasal drainage due to rhinosinusitis. Patients with VCD frequently complain of tightness in the throat and/or chest and may speak in a hoarse voice. Nocturnal symptoms are uncommon in uncomplicated VCD, but may occur in patients with both VCD and asthma. Exercise is a frequent precipitant of both VCD and asthma.

Upon presentation in an emergency department, increased work of breathing and decreased aeration caused by VCD can be difficult to distinguish from asthma. A report provides evidence that a normal level of oxygen saturation can be a clue that the cause of the distress is VCD rather than asthma.<sup>98</sup>

Spirometry and inhaled provocation challenges assist in the differentiation between VCD and asthma. Asthma typically produces abnormalities in the expiratory phase of the flow-volume loop, whereas VCD results in inspiratory loop abnormalities, such as blunting or truncation of the inspiratory loop due to variable extrathoracic airflow obstruction. Respiratory impedance during inspiration, as assessed by impulse oscillometry, has been reported to differentiate between patients with VCD and normal controls.<sup>99</sup> Provocation challenges, either pharmacological (methacholine or histamine) or exercise, are helpful in determining the presence or absence of airways hyperresponsiveness, a feature characteristic of asthma. Exercise challenges frequently reproduce clinical symptoms and spirometric abnormalities consistent with VCD. If this approach fails to establish the diagnosis or if the patient does not respond to appropriate therapy, direct visualization of paradoxical vocal cord movement during symptomatic periods may be helpful in confirming the diagnosis of VCD. Characteristic findings include adduction of the true vocal cords during inspiration with a diamond-shaped opening at the posterior aspect of the glottis. Once the diagnosis of VCD has been established, attention should focus on reassurance, maneuvers directed at laryngeal relaxation (from speech therapy) and discovering underlying

stress that is often involved in producing or exacerbating the problem (from psychology). In our experience, a combination of speech therapy and psychological evaluation is necessary for successful therapy for VCD. Maintenance therapy for VCD includes minimization of medication use for co-morbid conditions frequently confused with VCD (i.e. asthma).

### PSYCHOLOGICAL FACTORS

Psychological factors may be as, or even more, important than medical factors in determining outcomes of asthma, particularly in children with more severe asthma. In a group of children with severe asthma, 50% had levels of fitness in the significantly abnormal range.<sup>100</sup> Psychological functioning as determined by structured interviews significantly correlated with cardiopulmonary function, but medical characteristics did not.<sup>100</sup> Similar to the findings in studies of fitness levels, school performance<sup>101</sup> and gross and fine motor coordination,<sup>102</sup> while generally in a normal range (in contrast to the findings of fitness), overall correlated with psychological functioning but not the medical characteristics of the asthma. Depression symptoms, cigarette smoking and cocaine use occurred more frequently in youth reporting current asthma than in youth without asthma.<sup>103</sup> These results indicate a need to screen adolescents with asthma for depression.

At the level of characteristics of the individual caregiver, the beliefs that parents hold about their ability to manage their child's asthma and the quality of life that they maintain while caring for a child with asthma may be associated with asthma hospitalizations.<sup>104</sup> A health education intervention study conducted to improve asthma management skills and to build family self-confidence in the ability to manage asthma found that families that participated in the intervention reported better attack management strategies and preventive strategies compared to a control group.<sup>105</sup> Adults with asthma who have greater confidence or trust in the care they receive from their doctor report having better controlled asthma and are more likely to have mild, as opposed to severe, asthma.<sup>106</sup> Thus, parents who believe strongly that they cannot adequately care for their child's asthma may be more likely to bring their child to the hospital repeatedly for acute episodes.

### POOR ADHERENCE TO THE MEDICAL REGIMEN

Most patients receive suboptimal benefit from any given prescribed asthma regimen. This is often reflected as inadequate asthma control, and often leads to prescription of higher doses or additional controller medications based upon the assumption that the medication prescribed accurately reflects the medication the patient actually takes. However, since most patients miss substantial amounts of medications, even when participating in research studies examining medication adherence,<sup>107</sup> practitioners must focus on patient education regarding the importance of asthma medication use as directed and provision of a written plan of action which is practical for the patient. Complex regimens consisting of several medications given frequently during the day are less likely to be followed when compared to simple regimens with less frequent dosing requirements. When discussing asthma-related information and setting appropriate and achievable short- and long-term goals, excellence in communication and development of a partnership between healthcare providers and patients is essential in

establishing the foundation for asthma care and adherence to the recommended treatment approach.

The developmental level of the child complicates adherence in the pediatric population. Children's understanding of their asthma and the steps necessary to control the disease evolve over time. Thus, the action plan for each child must be individualized based upon the child's developmental stage. While children begin to acquire basic asthma decision-making abilities by the ages of 8 years, they remain unable to manage their asthma independently until about 16 years of age.

## OBESITY

Weight reduction in obese patients with asthma has been associated with improvement of lung function and other indicators of lung status.<sup>108</sup> Similar to the importance of monitoring height in children with asthma, both as an indicator of general wellness and the effects of medications used to treat asthma, comprehensive care in children with asthma includes monitoring weight acquisition and encouraging weight reduction. Recognition that obesity may produce respiratory symptoms that mimic but do not actually represent asthma is essential<sup>34</sup> to avoid inappropriate and unnecessary escalations of asthma therapy.

## EXERCISE

Exercise-induced asthma (EIA) may lead to decreased participation in physical activities due to either exertional limitation or fear of symptom development. This may explain the finding that children with asthma are less physically fit than their non-asthmatic peers.<sup>109</sup> Despite these facts, asthma should not be perceived as a limitation on physical fitness, as evidenced by the prevalence of asthma among Olympic athletes approximating twice that of the general population.<sup>110</sup> Increased aerobic fitness decreases EIA, as better conditioned individuals require smaller increases in heart rate and ventilation for a given task.<sup>109</sup> Thus, although EIA may still occur, more physical work can be done before it begins (see Chapter 36).

## Classification of Asthma Severity and Control

Asthma severity is currently classified as either intermittent or persistent disease (Table 34-2). While the distinction between intermittent and persistent disease, and even between the various levels of persistent disease, is arbitrary, it serves as a framework for severity classification and ultimately treatment recommendations. Asthma severity is most easily assessed in a patient not receiving long-term control therapy as this reflects the intrinsic intensity of the disease process. The assessment of asthma severity requires determination of morbidity in the domains of impairment and risk, where impairment reflects the frequency and intensity of symptoms and functional limitation experienced, and risk reflects the likelihood of asthma exacerbations. Four major features of asthma – daytime symptom frequency, nocturnal symptom frequency, interference with exercise and pulmonary function – define levels of severity in the impairment domain, and exacerbations requiring systemic corticosteroids define severity in the risk domain. Nocturnal symptoms are a particularly important marker of more severe disease.<sup>111</sup>

Although most previous national and international guidelines provide lung function measures that are suggested as those which correspond to each level of asthma severity, these parameters do not appear to be entirely appropriate for the classification of childhood asthma, since most children with persistent asthma, even severe asthma, have FEV<sub>1</sub> measures within the normal range ( $\geq 80\%$  predicted).<sup>112</sup> Current guidelines have improved on this by including the FEV<sub>1</sub>/FVC ratio as an additional lung function parameter to help assess asthma severity.<sup>111</sup> Thus, clinicians and researchers should focus upon a combination of symptom frequency and medication use in assigning a level of asthma severity rather than relying solely on isolated measures of lung function (either FEV<sub>1</sub> or PEF) as the primary determinants of asthma severity.

Once asthma therapy has been initiated, the ongoing assessment of asthma control becomes central to disease management. Asthma control is defined as the degree to which the manifestations of asthma are minimized by therapeutic intervention and the goals of therapy are met. Three levels of control (well-controlled, not well-controlled, and very poorly controlled) provide for gradations of control (Table 34-3) and emphasize the need to re-evaluate patients at every visit and adjust strategy if asthma is not well-controlled or is very poorly controlled. The concepts of impairment and risk are central in the determination of the level of control. Similar to the assessment of asthma severity, the impairment domain for control includes daytime symptom frequency, nocturnal symptom frequency, interference with exercise and pulmonary function, while the risk domain includes exacerbations requiring systemic corticosteroids, progressive loss of lung function or reduced lung growth, or risk of adverse effects of medications. The incorporation of the use of standardized and validated tools to assess asthma control, such as the Asthma Control Test<sup>60,61</sup> and Asthma Control Questionnaire,<sup>113</sup> can identify and monitor patients whose level of asthma control falls below the goals of therapy, prompting consideration of adjustment of therapy.

To maximize the outcome of asthma therapy, goals must be high and be clearly communicated to the child and family. Achievable goals for nearly all children with asthma are outlined in Box 34-1. Routine reassessment of patient attainment of these goals is a critical component of ongoing asthma care.

## Perception of Bronchoconstriction

Presence of symptoms is an important determinant of severity determinations. Interpretation of symptom histories must be undertaken in the context of over-reporting in anxious individuals, under-reporting in children who do not want to be bothered by limitations that may be imposed if symptoms were fully reported, and under-reporting in children who do not perceive their level of bronchoconstriction, either acutely or chronically. The last of these possibilities is the most worrisome because patients with asthma who have difficulty perceiving significant airway obstruction appear to be at risk for severe outcomes, such as hospitalization or even death. Review of studies in the literature on this subject do not provide clear guidelines on which patients should be considered as possibly being unable to perceive bronchoconstriction, indicating that lung function should be measured at regular office visits and the relationship between level of lung function and current symptoms discussed. The finding of a discrepancy between the level of lung function and current symptoms can

**TABLE 34-2**  
**Classification of Asthma Severity**

COMPONENT OF SEVERITY		CLASSIFICATION OF ASTHMA SEVERITY FOR DIFFERENT AGE GROUPS											
		INTERMITTENT				MILD				PERSISTENT			
		5-11 Years		≥12 Years		5-11 Years		≥12 Years		5-11 Years		≥12 Years	
Impairment	Symptoms	≤2 days/week	≤2 days/week	>2 days/week but not daily	>2 days/week but not daily	>2 days/week but not daily	>2 days/week but not daily	>2 days/week but not daily	>2 days/week but not daily	>2 days/week but not daily	>2 days/week but not daily	>2 days/week but not daily	>2 days/week but not daily
	Nighttime awakenings	0	0	1-2x/month	1-2x/month	3-4x/month	3-4x/month	3-4x/month	3-4x/month	3-4x/month	3-4x/month	3-4x/month	3-4x/month
Impairment	Short-acting β <sub>2</sub> -agonist use for symptom control	≤2 days/week	≤2 days/week	>2 days/week but not daily	>2 days/week but not daily	>2 days/week but not daily	>2 days/week but not daily	>2 days/week but not daily	>2 days/week but not daily	>2 days/week but not daily	>2 days/week but not daily	>2 days/week but not daily	>2 days/week but not daily
	Interference with normal activity	None	None	Minor limitation	Minor limitation	Minor limitation	Minor limitation	Minor limitation	Minor limitation	Minor limitation	Minor limitation	Minor limitation	Minor limitation
Impairment	Lung Function	• Normal FEV <sub>1</sub> between exacerbations	• Normal FEV <sub>1</sub> between exacerbations	• FEV <sub>1</sub> >80% predicted	• FEV <sub>1</sub> >80% predicted	• FEV <sub>1</sub> >80% predicted	• FEV <sub>1</sub> >80% predicted	• FEV <sub>1</sub> >80% predicted	• FEV <sub>1</sub> >80% predicted	• FEV <sub>1</sub> >80% predicted	• FEV <sub>1</sub> >80% predicted	• FEV <sub>1</sub> >80% predicted	• FEV <sub>1</sub> >80% predicted
		• FEV <sub>1</sub> >80% predicted	• FEV <sub>1</sub> >80% predicted	• FEV <sub>1</sub> >80% predicted	• FEV <sub>1</sub> >80% predicted	• FEV <sub>1</sub> >80% predicted	• FEV <sub>1</sub> >80% predicted	• FEV <sub>1</sub> >80% predicted	• FEV <sub>1</sub> >80% predicted	• FEV <sub>1</sub> >80% predicted	• FEV <sub>1</sub> >80% predicted	• FEV <sub>1</sub> >80% predicted	• FEV <sub>1</sub> >80% predicted
Risk	Exacerbations (consider frequency and severity)	0-2/year	0-2/year	>2 exacerbations in 1 year	>2 exacerbations in 1 year	>2 exacerbations in 1 year	>2 exacerbations in 1 year	>2 exacerbations in 1 year	>2 exacerbations in 1 year	>2 exacerbations in 1 year	>2 exacerbations in 1 year	>2 exacerbations in 1 year	>2 exacerbations in 1 year
		Relative annual risk may be related to FEV <sub>1</sub> Frequency and severity may fluctuate over time Exacerbations of any severity may occur in patients in any severity category	Relative annual risk may be related to FEV <sub>1</sub> Frequency and severity may fluctuate over time Exacerbations of any severity may occur in patients in any severity category	Relative annual risk may be related to FEV <sub>1</sub> Frequency and severity may fluctuate over time Exacerbations of any severity may occur in patients in any severity category	Relative annual risk may be related to FEV <sub>1</sub> Frequency and severity may fluctuate over time Exacerbations of any severity may occur in patients in any severity category	Relative annual risk may be related to FEV <sub>1</sub> Frequency and severity may fluctuate over time Exacerbations of any severity may occur in patients in any severity category	Relative annual risk may be related to FEV <sub>1</sub> Frequency and severity may fluctuate over time Exacerbations of any severity may occur in patients in any severity category	Relative annual risk may be related to FEV <sub>1</sub> Frequency and severity may fluctuate over time Exacerbations of any severity may occur in patients in any severity category	Relative annual risk may be related to FEV <sub>1</sub> Frequency and severity may fluctuate over time Exacerbations of any severity may occur in patients in any severity category	Relative annual risk may be related to FEV <sub>1</sub> Frequency and severity may fluctuate over time Exacerbations of any severity may occur in patients in any severity category	Relative annual risk may be related to FEV <sub>1</sub> Frequency and severity may fluctuate over time Exacerbations of any severity may occur in patients in any severity category	Relative annual risk may be related to FEV <sub>1</sub> Frequency and severity may fluctuate over time Exacerbations of any severity may occur in patients in any severity category	Relative annual risk may be related to FEV <sub>1</sub> Frequency and severity may fluctuate over time Exacerbations of any severity may occur in patients in any severity category

From Program NAEaP. Expert Panel Report III: Guidelines for the diagnosis and management of asthma. Bethesda, MD: US Department of Health and Human Services; 2007.

TABLE  
34-3Classification of Asthma Control in Youths  $\geq 12$  Years of Age and Adults

COMPONENT OF CONTROL		CLASSIFICATION		
		Well-Controlled	Not Well-Controlled	Very Poorly Controlled
Impairment	Symptoms	$\leq 2$ days/week	$> 2$ days/week	Throughout the day
	Nighttime Awakenings	$\leq 2$ /month	1–3/week	$\geq 4$ /week
	Interference with normal activity	None	Some limitation	Extremely limited
	Short-acting $\beta_2$ -agonist use for symptom control	$\leq 2$ days/week	$> 2$ days/week	Several times per day
	FEV <sub>1</sub> or peak flow	$> 80\%$ predicted/ personal best	60–80% predicted/ personal best	$< 60\%$ predicted/ personal best
	Validated Questionnaires			
	ATAQ	0	1–2	3–4
Risk	ACQ	$\leq 0.75$	$\geq 1.5$	N/A
	ACT	$\geq 20$	16–19	$\leq 15$
	Exacerbations (consider frequency and severity)	0–1/year	2–3/year	$> 3$ /year
Progressive loss of lung function		Evaluation requires long-term follow-up		
Treatment-related adverse effects		Medication side-effects can vary in intensity from none to very troublesome and worrisome. The level of intensity does not correlate to specific levels of control but should be considered in the overall assessment of risk		

From Program NAEaP. Expert Panel Report III: Guidelines for the diagnosis and management of asthma. Bethesda, MD: US Department of Health and Human Services; 2007.

### BOX 34-1 GOALS OF ASTHMA TREATMENT

#### REDUCING IMPAIRMENT

- Prevent chronic and troublesome symptoms (e.g. coughing or breathlessness in the daytime, in the night or after exertion)
- Require infrequent use ( $\leq 2$  days a week) of short-acting  $\beta_2$ -agonist for quick relief of symptoms (not including prevention of exercise-induced bronchospasm)
- Maintain (near) normal pulmonary function
- Maintain normal activity levels (inducing exercise and other physical activity and attendance at work or school)
- Meet patients' and families' expectations of and satisfaction with care

#### REDUCING RISK

- Prevent recurrent exacerbations of asthma and minimize the need for emergency department visits or hospitalizations
- Prevent loss of lung function; for children, prevent reduced lung growth
- Minimal or no adverse effects of therapy

Adapted from Program NAEaP. Expert Panel Report III: Guidelines for the Diagnosis and Management of Asthma. Bethesda, MD: US Department of Health and Human Services; 2007.

be an important part of the education and planning for future exacerbations; a child with no symptoms but with low lung function needs to be aware that any symptoms might mean severe problems are present. Such a child is one who might benefit from regular use of a peak flow meter, not stopping measurements when well as most children tend to do.

## Treatment of Childhood Asthma

Achieving optimal control of asthma requires a comprehensive approach that addresses the underlying pathophysiological disturbances. Thus, in addition to the pharmacological approach to asthma, one must minimize exposure to asthma triggers, including environmental allergens (see Chapter 22) and

nonspecific airway irritants (such as tobacco smoke), and treat concomitant medical conditions which influence asthma severity (such as GER and rhinosinusitis). Equally important is providing asthma education and support for the child and family in the process of chronic disease management.

## Severity-Based Asthma Management

Once asthma has been diagnosed and a level of severity based upon the algorithm assigned, attention should shift toward the development of a comprehensive treatment plan (see Table 34-3). A central element to any treatment regimen is a written action plan, which provides the child and family with a clearly defined approach towards asthma management, including medications for routine daily use and a rescue plan for exacerbations, including medication modifications and signs of asthma symptom progression which should prompt contact with the healthcare provider or seeking of emergency care.

## Pharmacological Management

Currently, asthma medications are divided into two major categories – those that provide rapid relief of asthma symptoms (quick relievers) and those that serve to decrease airway inflammation and improve asthma on an ongoing basis (long-term controllers). The choice of medications for a given patient depends upon the level of asthma severity and control (Figure 34-2).

Intermittent asthma is managed with as needed use of short-acting  $\beta_2$ -agonists by inhalation. However, all patients with persistent asthma should receive one, or potentially a combination of, controller medication(s) that possess anti-inflammatory properties.

## Controller Medications

The inflammatory nature of persistent asthma supports the use of medications aimed at decreasing, and ideally eliminating, airway inflammation. Thus, agents with anti-inflammatory



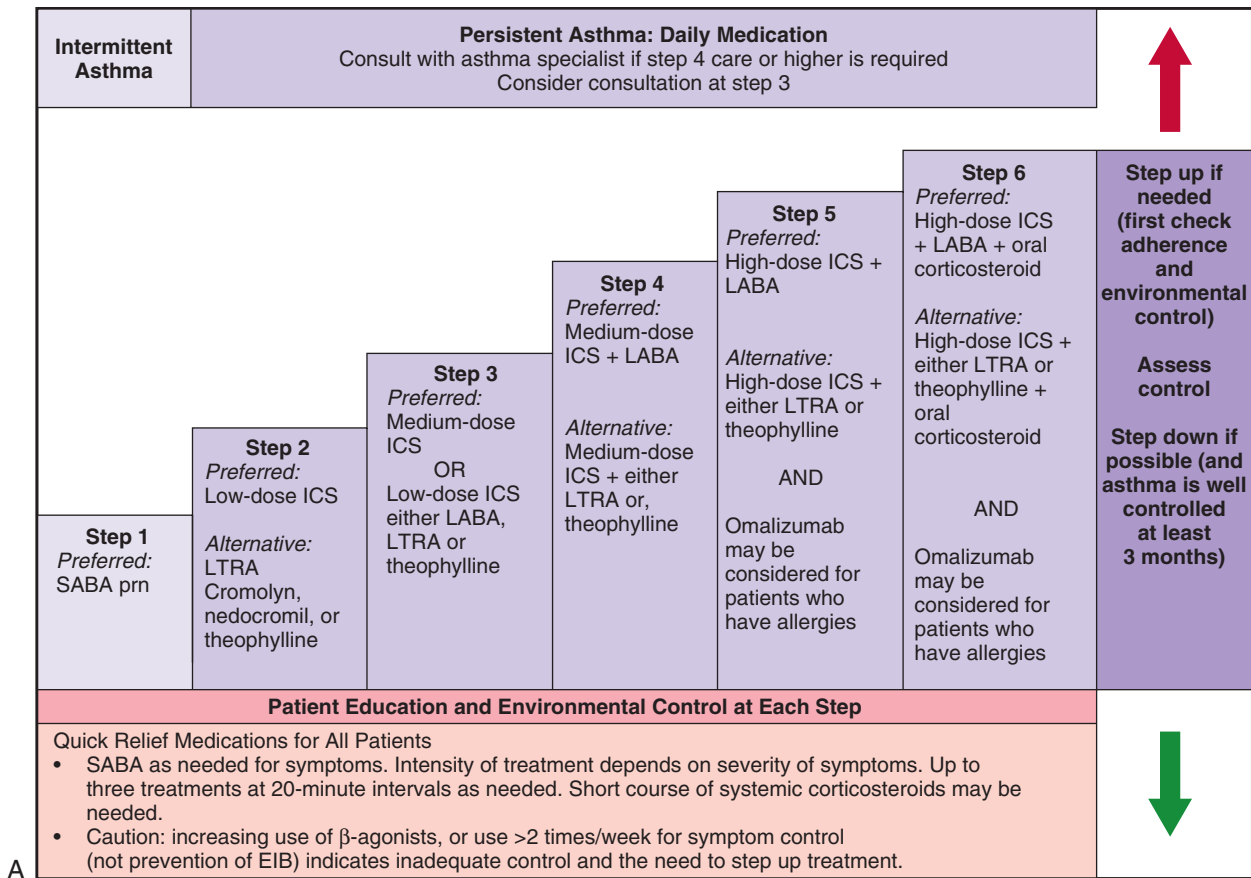

A

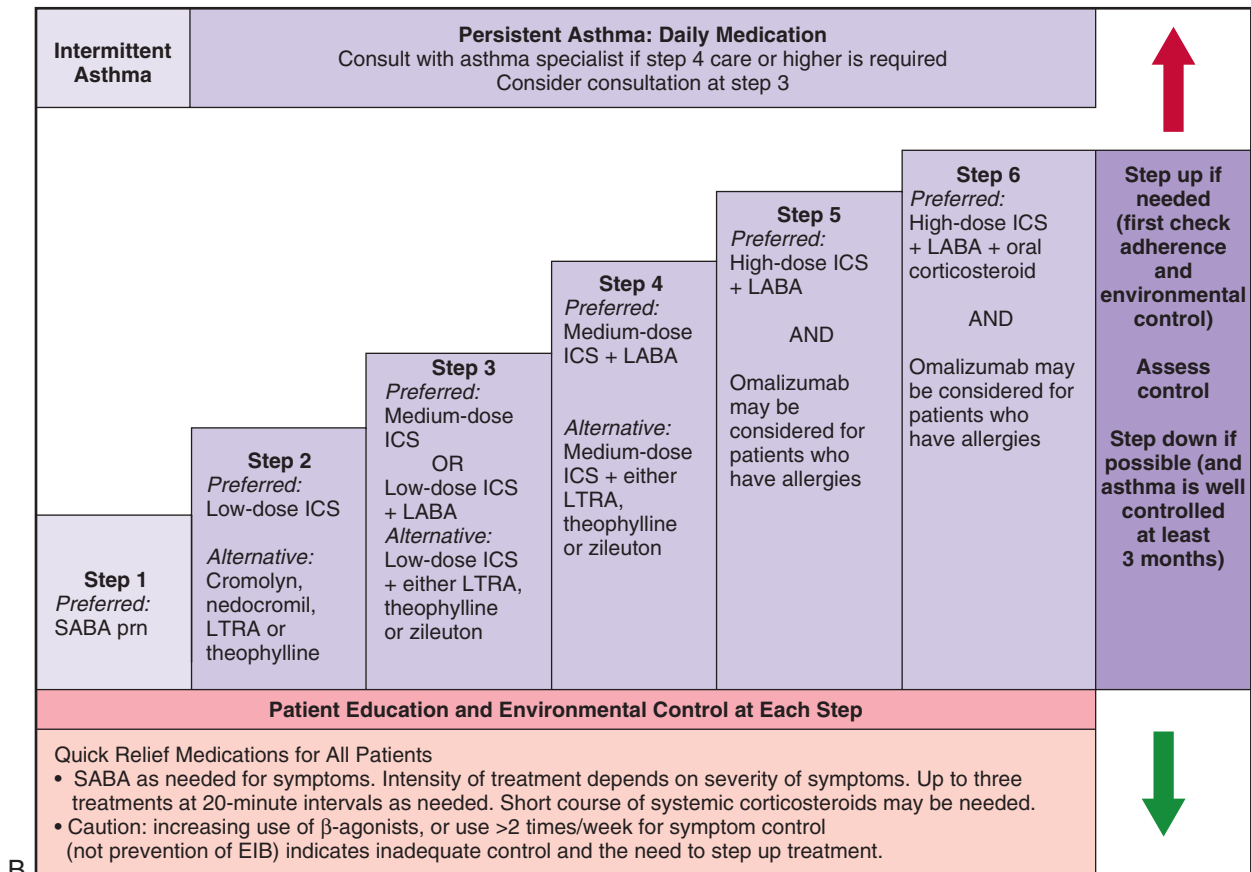

B

**Figure 34-2** Stepwise approach for managing children with asthma. (A) 5–11 years of age. (B)  $\geq 12$  years of age. SABA – short-acting  $\beta$ -antagonist, ICS – inhaled corticosteroid, LTRA – leukotriene receptor antagonist, LABA – long-acting  $\beta$ -antagonist, EIB – exercise-induced bronchoconstriction. (From Program NAEaP. Expert Panel Report III: Guidelines for the diagnosis and management of asthma. Bethesda, MD: US Department of Health and Human Services; 2007.)

properties are essential in the treatment plan of all children with persistent asthma.

## INHALED CORTICOSTEROIDS

Inhaled corticosteroids (ICSs) are the most effective long-term controller medication for asthma in childhood. ICS therapy leads to significant improvement in asthma control as reflected by reductions in asthma symptom frequency and severity, exacerbation rates, hospitalizations, asthma death, quality of life and airway hyperresponsiveness. Short-term studies of ICS therapy have reported improvements in measures of lung function and reduction in inflammatory cells and other markers of inflammation within the airways.

The CAMP, the largest and longest prospective clinical trial of ICS therapy in children, examined the effect of three treatment strategies in 1,041 children with mild-to-moderate asthma.<sup>114</sup> Children received either (1) an ICS (budesonide 200 µg bid), or (2) a nonsteroidal agent with anti-inflammatory properties (nedocromil sodium 4 mg bid) or (3) a matching placebo for an average of 4.3 years of continuous therapy. All children received albuterol as needed for symptoms, and oral steroids for exacerbations. The primary outcome of the study was the FEV<sub>1</sub> after bronchodilator following a mean of 4.3 years of therapy. Children treated with ICSs demonstrated an initial rise in FEV<sub>1</sub> over the first 6 to 12 months of the trial, but upon completion of the trial the ICS group and the placebo group did not differ in terms of FEV<sub>1</sub>. Children who received ICS therapy experienced numerous clinical benefits not experienced by children who received placebo, including significant improvement in airway hyperresponsiveness, fewer asthma symptoms, less albuterol use, more days without an asthma episode, a longer time until need for oral corticosteroids for an asthma exacerbation, fewer courses of oral corticosteroids, fewer urgent care visits and hospitalizations, and less need for supplemental ICS therapy due to poor asthma control. The clinically meaningful improvements in control of asthma achieved during continuous treatment with ICSs do not persist after continuous treatment is discontinued.<sup>72,115,116</sup>

Guidelines for asthma management suggest that increasing levels of asthma severity or poor asthma control require increasing doses of ICSs to achieve disease control. Several studies support a dose-response relationship for ICSs. However, this relationship is nonlinear and is complicated by the dose-side-effect relationship. Low doses of ICSs (as low as 200 µg/day of budesonide<sup>117</sup> or 50 µg bid of fluticasone propionate<sup>118</sup>) have been demonstrated to be effective in controlling asthma in children with persistent asthma. Furthermore, each child is likely to demonstrate an individual ICS dose-response relationship, as demonstrated in adults.<sup>119</sup> In addition, the rates of improvement of individual measures of asthma control vary, with symptom control and peak flow measures generally responding to low-dose ICS therapy within 2 to 4 weeks,<sup>117</sup> while treatment with higher doses for longer periods of time are necessary to maximize the effect on airway hyperresponsiveness.<sup>114</sup> Thus, ICS dosing must be tailored to the individual patient's needs and response to therapy.

In general, ICS therapy is well-tolerated by the majority of patients. However, potential side-effects of ICS therapy include the effects of ICSs upon skeletal growth and bone density, alteration of the hypothalamic-pituitary-adrenal (HPA) axis and local side-effects including oral candidiasis and hoarseness.

The effect of ICS therapy on growth during childhood has been extensively studied. However, many of the conclusions from these investigations are difficult to fully appreciate, as many studies are of short-to-intermediate durations (generally ranging from 8 to 12 weeks to 1 year). ICS therapy has been shown to result in short-term reductions in rates of linear growth in children, an effect which is most evident in prepubertal children. These effects are dose- and drug-dependent, with no significant effect on growth when low doses (100–200 µg/day of fluticasone propionate) are used for up to 1 year.<sup>72,120</sup> CAMP demonstrated that children receiving ICS therapy for 4 to 6 years grew an average of 1.1 cm less than those receiving placebo. The growth effect was in the first year of treatment without additional effect as treatment continued. When adult height was predicted using standardized measures based upon current height, current age, bone age and age at first menses (for females), the ICS-treated children and the placebo-treated children had similar projected final heights.<sup>114</sup> However, the effect of ICS therapy on growth persisted 5 years after regular ICS therapy was discontinued, with evidence that the effect is more pronounced in girls than boys,<sup>115</sup> similar findings have been reported in other populations.<sup>121–123</sup> Follow-up of the CAMP population until achievement of adult height demonstrated that the initial decrease in attained height associated with the use of ICSs persisted as a reduction in final adult height, although the decrease was neither progressive nor cumulative.<sup>124</sup>

Numerous studies have examined the effect of ICS therapy on HPA axis function with conflicting results. While the available evidence suggests that low-to-moderate dose ICS therapy is generally not associated with alterations in HPA function,<sup>125,126</sup> the long-term effects of high-dose ICS therapy in growing children remain unclear. The interaction between ICS use and bone mineral density (BMD) was studied thoroughly in CAMP; ICS therapy has the potential to reduce bone mineral accretion in male children progressing through puberty, although the ability of ICS to reduce the need for oral corticosteroid therapy (and the attendant reduction in BMD) largely outweighs this small risk.<sup>127</sup> The effect of high-dose ICS therapy on BMD in growing children remains uncertain.

There has been some concern that ICSs may cause the course of chicken pox to worsen, based upon case reports of death from chicken pox in individuals on high doses of *oral* steroids. There have been no deaths with ICSs alone, but clinicians caring for children with persistent asthma should assure varicella immunity, either through prior natural infection or through vaccination, and be prepared to minimize ICS use and to add antiviral agents should chicken pox occur in individuals on ICSs.

## LEUKOTRIENE MODIFIERS

The cysteinyl leukotrienes (LTC<sub>4</sub>/LTD<sub>4</sub>/LTE<sub>4</sub>) are mediators produced by eosinophils and mast cells and trigger many processes central to asthma – mucus secretion, bronchoconstriction and increased vascular permeability. The clinical effects of agents which modulate leukotriene activity confirm the role of these mediators in the pathophysiology of asthma. Clinical trials have demonstrated the positive effects of LT antagonism on pulmonary function and clinical outcomes in children with asthma.<sup>128</sup>

Montelukast, a selective leukotriene receptor 1 antagonist, improved pulmonary function, reduced rescue albuterol use, improved quality of life and decreased peripheral blood eosinophil counts over an 8-week period in children aged 6 to 14 years with moderate asthma compared with placebo.<sup>128</sup> Montelukast has also been shown to inhibit exercise-induced bronchoconstriction in children with mild-to-moderate asthma.<sup>129</sup> In addition to having positive effects as monotherapy, leukotriene modifiers (LTMs) appear to have additive properties when given with ICSs.<sup>130,131</sup>

The inflammatory nature of asthma currently demands that controller medications possess anti-inflammatory properties. While the data regarding the anti-inflammatory attributes of LTMs is limited compared to those of ICSs, several studies strongly suggest that these agents decrease markers of allergic airway inflammation, including peripheral blood<sup>128</sup> and sputum eosinophils,<sup>132</sup> nitric oxide in exhaled air,<sup>75,133</sup> bronchial hyperreactivity<sup>134</sup> and cellular infiltrates in BAL fluid following segmental allergen challenge.<sup>135</sup>

While the long-term effects of antileukotriene therapy are unknown, these agents possess desirable clinical and biological properties and deserve consideration in children with all levels of persistent asthma. These agents have excellent safety records in children and the oral delivery system makes these agents easy to administer to children. Evidence supporting ICSs as the preferred maintenance therapy over montelukast in school-age children with mild persistent asthma (Step 2) has come from several sources. A multicenter, randomized, double-blind trial demonstrated that clinical outcomes, pulmonary responses and inflammatory biomarkers improved more with fluticasone 100 µg twice daily compared to daily montelukast in children aged 6 to 17 years with mild-to-moderate persistent asthma.<sup>116</sup> The Pediatric Asthma Controller Trial (PACT), a year-long, randomized, double-blind trial in children aged 6 to 14 years with mild-to-moderate persistent asthma also demonstrated the superiority of the ICS fluticasone over montelukast therapy for asthma control days, exacerbations, quality of life and pulmonary function.<sup>72,136</sup> Based upon these data, current guidelines support the use of LTRAs as an alternative to ICSs as monotherapy in mild persistent asthma as well as adjunctive therapy in moderate-to-severe asthma.<sup>111</sup>

## LONG-ACTING $\beta$ -AGONISTS

Two long-acting  $\beta_2$ -adrenergic agonists (LABAs), salmeterol and formoterol, have been demonstrated to be safe and effective agents in children, both in terms of bronchodilation and prevention of exercise-induced bronchospasm. Their onsets of action differ, with formoterol having an onset similar to that of albuterol (3 minutes), while salmeterol has a slower onset of action (10–20 minutes). Following administration of a single dose, both agents demonstrate durations of action of up to 12 hours. Following regular twice daily administration, bronchodilation remains effective; however, a level of tolerance (or tachyphylaxis) develops, manifested as a loss of bronchoprotective properties to stimuli such as exercise, methacholine and allergen, although the clinical relevance of these findings is unclear.

The complementary actions of ICSs and LABAs suggest that these agents should be effective when used in combination. Extensive data in adults confirm the superiority of the addition

of a LABA to patients uncontrolled on ICSs compared to increasing the dose of the ICS alone.<sup>137,138</sup> The PACT trial also included a combination therapy arm consisting of fluticasone (100 µg once daily) plus the LABA salmeterol (50 µg twice daily).<sup>72</sup> This combination of once-daily ICS therapy plus a twice-daily LABA was associated with comparable asthma control to the twice-daily fluticasone approach in terms of the proportion of asthma control days and Asthma Control Questionnaire scores, but was inferior to fluticasone alone in terms of changes in lung function, airway hyperresponsiveness and exhaled nitric oxide levels. Among children with asthma inadequately controlled by an ICS alone, the addition of a LABA led to improved lung function and symptom control compared to placebo.<sup>139</sup> In contrast, one study found no advantage with the addition of salmeterol to low-dose ICS therapy compared with a doubling of the ICS dose in children with mild-to-moderate asthma.<sup>140</sup> Studies in adults also suggest that LABAs may facilitate ICS reduction in patients whose asthma is controlled on a moderate-to-high dose of ICS.<sup>112,141</sup> While the addition of a LABA to an ICS improves lung function, a recent Cochrane Review concluded that there is no evidence to date that the addition of a LABA to ICS therapy reduces significant asthma exacerbations in children.<sup>142</sup> However, in a recent trial among children aged 6 to 17 years with asthma not controlled with low-dose ICS monotherapy, the addition of the LABA salmeterol to low-dose ICS was more likely to provide a better response than the addition of an LTRA or doubling the dose of ICS,<sup>138</sup> and treatment with ICS + LABA was associated with the fewest exacerbations. The addition of LABA therapy may increase the risk of rare life-threatening or fatal asthma exacerbations, and thus should be carefully considered in children with asthma inadequately controlled with ICS therapy alone.<sup>111</sup> More clinical trials are necessary to fully determine the role of LABAs in the management of persistent asthma in childhood. However, the compelling evidence of the efficacy of ICS + LABA therapy in older children and adults has led to the recommendation of a combination of ICS and LABAs as the preferred therapy in children aged 5 years and older whose asthma severity and/or control indicate the need for Step 4 care (see [Figure 34-2](#)).<sup>111</sup>

## CROMOLYN AND NEDOCROMIL

Cromolyn sodium and nedocromil sodium are inhaled agents that are alternatives to ICSs in the management of mild persistent asthma in children. Both drugs have been shown to possess anti-inflammatory properties through nonsteroidal mechanisms, although the exact mechanisms for their actions remain unclear. Both agents are effective in the short-term prevention of exercise-induced bronchospasm. Several clinical trials have suggested beneficial effects with regular administration of cromolyn, although a meta-analysis suggests that there is insufficient evidence to support the use of cromolyn as maintenance therapy for asthma.<sup>143</sup> Nedocromil (8 mg/day) therapy for approximately 4 years in children with mild-to-moderate asthma resulted in a reduction in oral corticosteroid use and urgent care visits for asthma compared to placebo/albuterol for symptoms only, but did not affect lung function or rescue albuterol use compared with placebo.<sup>114</sup> These agents are generally well-tolerated, with cough, sore throat and bronchoconstriction being the most common side-effects to cromolyn. Nedocromil

is more commonly associated with bad taste, headache and nausea than cromolyn.

## THEOPHYLLINE

Theophylline acts as an inhibitor of phosphodiesterase, although at therapeutic serum levels phosphodiesterase inhibition is weak yet bronchodilation occurs. Theophylline also inhibits the effects of adenosine, a molecule known to induce airway narrowing.

Theophylline is more effective than placebo in controlling asthma symptoms and pulmonary function, and is particularly effective in preventing nocturnal asthma symptoms. Current guidelines suggest theophylline as an alternative to ICSs in children with mild persistent asthma and as an add-on therapy with a low-dose ICS in children with moderate-to-severe asthma.<sup>111</sup> Patients may experience deterioration of asthma control following withdrawal of theophylline from their regimen.<sup>144,145</sup>

Theophylline has the potential for significant toxicity occurring with increasing serum concentrations. The benefits of theophylline may be recognized at lower serum levels than previously recommended (a target range of 5–15 µg/mL).<sup>111</sup> Serum drug level monitoring is needed with doses above 12 mg/kg or if side-effects occur. Theophylline metabolism is age dependent, with younger children having greater rates of metabolism than older children and adolescents. Drug interactions may lead to decreased theophylline metabolism, and thus increased serum levels (such as macrolide antibiotics [erythromycin, clarithromycin], cimetidine, ciprofloxacin) or increased theophylline metabolism, and thus lower serum levels (such as carbamazepine, phenobarbital, phenytoin, and rifampin). Febrile illnesses may result in decreased theophylline clearance, whereas tobacco and marijuana smoking result in accelerated clearance. Side-effects of theophylline are often dose dependent and include anorexia, nausea, emesis and headache. The effects of theophylline on psychomotor functioning and school performance have been examined and have generally shown no significant negative on learning or behavior.<sup>146</sup>

## ALLERGEN IMMUNOTHERAPY

Specific immunotherapy (SIT) is the repetitive parenteral injection of allergen extracts to reduce the manifestations of allergy caused by natural exposure to those allergens.<sup>147,148</sup>

Allergen-specific immunotherapy has been demonstrated to have beneficial effects in the management of childhood asthma, including effects on symptom control, medication use and airway hyperresponsiveness.<sup>149</sup> A recent meta-analysis examining the efficacy of allergen-specific immunotherapy concluded that there is moderate strength evidence that subcutaneous immunotherapy improves asthma symptoms and high strength evidence that sublingual immunotherapy improves asthma symptoms.<sup>150</sup> Furthermore, the majority of studies demonstrating efficacy of subcutaneous immunotherapy involved single allergen immunotherapy, whereas most children with asthma are polysensitized.<sup>151,152</sup> Allergen immunotherapy should not be initiated in patients with asthma that is not stable to pharmacotherapy.<sup>149</sup>

SIT of monosensitized children may prevent the development of both additional sensitivities and asthma.<sup>147</sup> Specific immunotherapy to pollens in children aged 6 to 14 years with

allergic rhinoconjunctivitis without asthma led to fewer asthma symptoms after 3 years of therapy, suggesting that SIT can reduce the development of asthma in children with seasonal allergic rhinoconjunctivitis.<sup>153</sup>

## OMALIZUMAB

A humanized monoclonal antibody directed against IgE (anti-IgE or omalizumab) rapidly and significantly reduces circulating levels of IgE. Repeated subcutaneous administration of omalizumab has been demonstrated to be safe<sup>154</sup> and effective in permitting reduction of ICS dosing while preventing asthma exacerbations in placebo-controlled trials in both adults<sup>155</sup> and children<sup>156</sup> with moderate-to-severe persistent allergic asthma receiving ICSs, as well as improving asthma-related quality of life.<sup>157</sup> Omalizumab is currently approved as an adjunctive therapy for children aged 12 years and older with moderate-to-severe persistent allergic asthma whose symptoms are inadequately controlled with ICS therapy, and the National Asthma Education and Prevention Program (NAEPP) Guidelines support its use when Step 5 or 6 care is indicated.<sup>111</sup>

## Quick Reliever Medications

### β<sub>2</sub>-ADRENERGIC AGONISTS

Rapid acting inhaled β<sub>2</sub>-adrenergic receptor agonists are the most effective bronchodilator agents currently available and serve as the preferred treatment for acute symptoms and exacerbations of asthma as well as the prevention of exercise-induced asthma. These agents stimulate the β<sub>2</sub>-adrenergic receptors located on bronchial smooth muscle and trigger a signaling cascade culminating in the generation of intracellular cyclic adenosine monophosphate (cAMP). In addition to relaxation of airway smooth muscle, β<sub>2</sub>-agonists stimulate mucociliary transport, modulate the release of mast cell mediators and decrease edema formation.

β<sub>2</sub>-Agonists are available for inhalation (by metered dose inhalers and nebulizers), oral administration (syrup and sustained-release tablets) and parenteral (subcutaneous and intravenous) administration. Inhalation is the preferred route of delivery as it maximizes efficacy and minimizes side-effects. Several different β<sub>2</sub>-agonists are currently available, and have comparable efficacy and safety properties. The single isomer preparation of albuterol, levalbuterol, has the theoretical advantage of possessing bronchodilatory properties (*R*-isomer of albuterol) without the presence of the nonbronchodilatory isomer (*S*-albuterol). Clinical trials with this agent demonstrate minimal clinically relevant differences in bronchodilation or side-effects related to β-adrenergic receptor stimulation, such as tachycardia, tremor and decreases in serum potassium levels, compared to racemic albuterol.<sup>158</sup>

### ANTICHOLINERGIC AGENTS

Potential mechanisms by which cholinergic pathways contribute to asthma pathophysiology include bronchoconstriction through increased vagal tone, increased reflex bronchoconstriction due to stimulation of airway sensory receptors, and increased acetylcholine release induced by inflammatory mediators.<sup>159</sup> Patients with asthma experience lesser degrees of



bronchodilation with anticholinergic agents (such as atropine and ipratropium bromide) than with  $\beta_2$ -agonists. There is presently no indication for anticholinergic agents as a component for long-term asthma control. Evidence supports the use of ipratropium bromide in conjunction with inhaled  $\beta_2$ -agonists in the emergency department during moderate-to-severe acute exacerbations of asthma in children.<sup>160,161</sup> This effect is most evident in patients with very severe exacerbations. Addition of ipratropium has been shown to decrease rates of hospitalization<sup>160</sup> and duration of time in the emergency department.<sup>161</sup>

## SYSTEMIC CORTICOSTEROIDS

Systemic steroids are valuable in gaining control of asthma symptoms in patients under poor control. Although the onset of action of systemic corticosteroids is slower than that of inhaled bronchodilators, there is evidence that corticosteroids have a faster onset of action than that suggested by their primary mechanisms of action, namely inhibiting the function of inflammatory cells and the secretion of cytokines, chemokines and other proinflammatory mediators. Corticosteroids rapidly up-regulate  $\beta_2$ -adrenoreceptor number and improve receptor function, likely leading to clinical improvement within 4 hours of administration.

Systemic corticosteroids hasten the resolution of acute exacerbations of asthma. Corticosteroid administration in the emergency department decreases admission rates for asthma<sup>162</sup> and shortens the length of stay in hospital. Dosing recommendations for acute asthma range from 1 to 2 mg/kg of body weight per day of prednisone. There is no significant difference in the efficacy of oral or parenteral corticosteroids in acute asthma,<sup>163</sup> unless the child is unable to tolerate oral medications due to vomiting. Given the well-described side-effect profile of repeated or continuous use of systemic corticosteroids, dosing should always be minimized. Rare patients with severe asthma may require regular corticosteroid therapy to gain or maintain disease control. In these situations, alternate-day dosing is associated with fewer adverse effects, but a very small percentage of patients with severe disease may still require daily steroid administration. Side-effects associated with chronic corticosteroid use in severe asthma include hypertension, cushingoid features, decreased morning serum cortisol levels, osteopenia, growth suppression, obesity, hypercholesterolemia and cataracts.<sup>164</sup> There is no evidence for clinically significant HPA axis suppression following short 'bursts' of systemic corticosteroids for acute exacerbations of asthma, and tapering is not required with courses of 10 to 14 days or less in duration. Furthermore, there is no evidence for increased susceptibility to common acute infections.<sup>165</sup>

## Management of Acute Asthma Episodes

Asthma exacerbations occur frequently and may occur even in the context of regular use of long-term controller therapy. Most exacerbations, especially those which are mild in nature, can generally be managed without difficulty at home. However, success in outpatient care of acute asthma demands excellent preparation, including a written set of instructions to help guide the patient and his/her family. The Asthma Action Plan is the central component for home asthma management.

Patients must be instructed as to the early and accurate recognition of changes in asthma status, as early intervention is likely to lessen the severity and rate of progression of the episode. An algorithm which serves as the basis for the action plan and allows for telephone triage and recommendations is shown in Figure 34-3.

At the onset of asthma symptoms, including cough, chest tightness, wheeze, shortness of breath, or with a decline in PEF below 80% of personal best, initial therapy should include administration of a rapid-acting bronchodilator such as albuterol, either via a metered dose inhaler (with a spacer device) or nebulizer. This treatment may be repeated up to three times in the first hour, with PEF measured before and after each albuterol administration. Patients who demonstrate rapid improvement following this intervention should be closely followed over the ensuing hours and days for signs of recurrence of symptoms, with a particular attention to nocturnal awakenings. Given the potential for progression of symptoms, addition (or increasing the dose) of an ICS is often recommended. Increased use is continued until baseline status is achieved and then for an additional 7 to 10 days because of the time needed for resolution of the increased inflammation produced during the exacerbation. Failure of this rescue approach to markedly reduce symptoms and improve PEF to >80% of personal best should lead to institution of systemic corticosteroids. Several protocols for administration of oral corticosteroids are commonly used. One such approach is to give prednisone, 2 mg/kg/day (up to 60 mg) for 5 days. The approach used in the CAMP trial, 2 mg/kg/day (up to 60 mg) for 2 days followed by 1 mg/kg/day (up to 30 mg) for 2 days,<sup>166</sup> decreased overall steroid exposure and was very effective in resolving exacerbations in patients with mild-to-moderate asthma. This should be accompanied by frequent reassessment of clinical status and PEF as well as albuterol every 4 to 6 hours, more frequently if needed. Patients who do not improve with this approach are experiencing moderate-to-severe exacerbation and may need further evaluation and intervention, generally in the physician's office or in the emergency department. Signs of worsening respiratory distress should prompt emergent evaluation and therapy.

## Conclusions and Summary

Asthma can significantly impact on the quality of life of both children and their families. Careful attention to the details of determining severity and applying an appropriate therapeutic regimen can control asthma symptoms in almost all children (see Key Concepts). In determining severity and applying the appropriate regimen, it is essential to establish good communication about the goals of therapy and to understand the family dynamics to assure the family can adhere to the therapeutic regimen prescribed. Ongoing evaluation based on communication of current symptoms, with regular assessment of the family's ability to adhere to therapeutic recommendations and the appropriateness of recommendations, is necessary for long-term control of the disease and minimization of side-effects of medications. Review of actions to take during exacerbation, using the Asthma Action Plan as the central mechanism of communication, is part of regular visits for asthma.

The complete reference list can be found on the companion Expert Consult website at <http://www.expertconsult.inkling.com>.

Follow this plan for After Hours patients only. Nurse may decide not to follow this home management plan if:

- Parent does not seem comfortable with or capable of following plan
- Nurse is not comfortable with this plan, based on situation and judgment
- Nurse's time does not allow for callbacks

In all cases, tell parent to call 9-1-1 if signs of respiratory distress occur during the episode

NOTE: If action plan has already been attempted without success, go to "RED ZONE - poor response" or "YELLOW ZONE - incomplete response" as symptoms indicate.

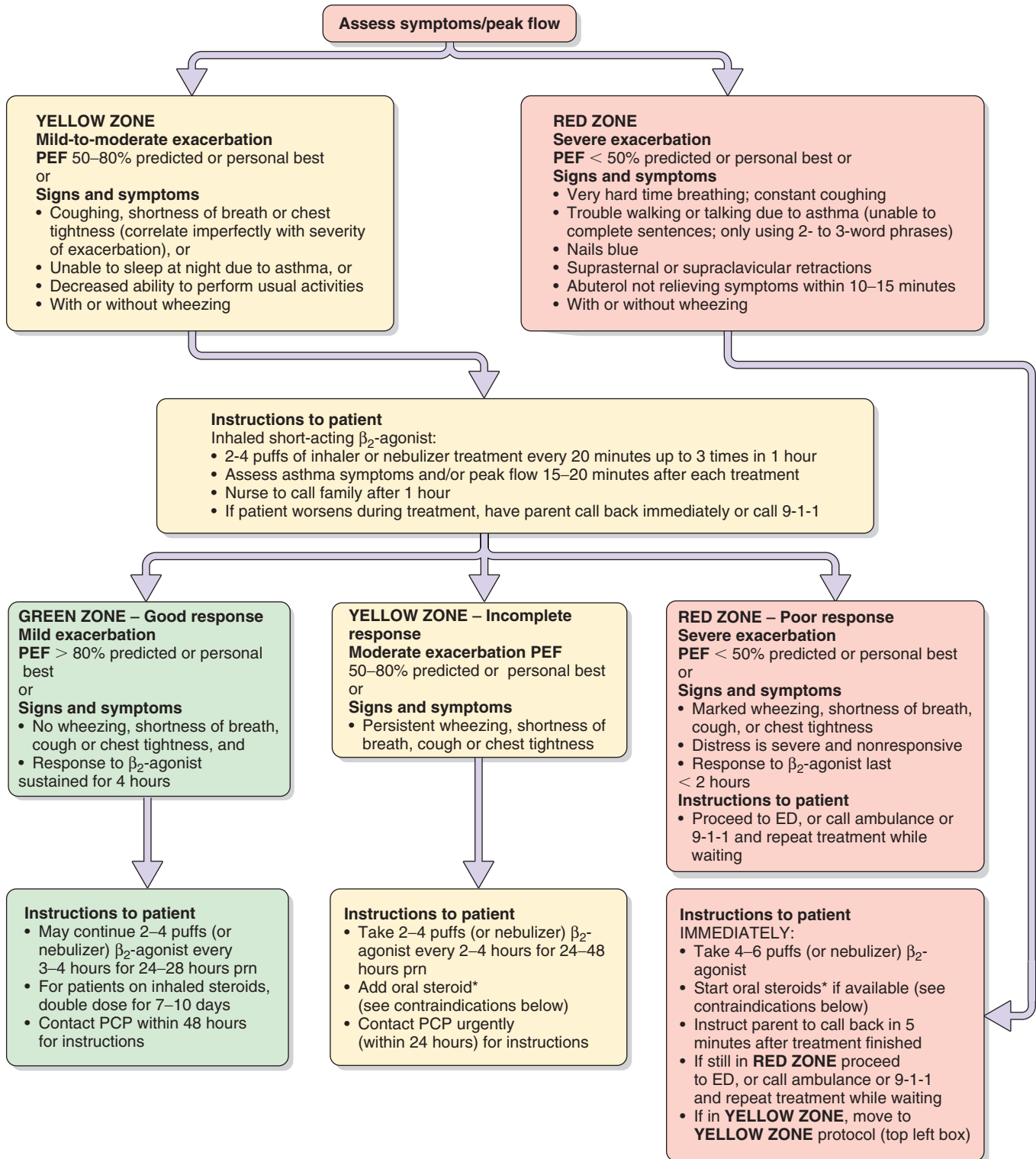

Documentation faxed or given to PCP within 24 hours; phone or verbal contact sooner as indicated.

\* Ask patient about preexisting conditions that may be contraindications to oral steroids (including type 1 diabetes, active chicken pox, chicken pox exposure or varicella vaccine within 21 days, MMR within 14 days). If so, nurse to contact PCP before initiating steroids. Oral steroid dosages: Child: 2 mg/kg/day, maximum 60 mg/day, for 5 days.

Date: \_\_\_\_\_  
Signature \_\_\_\_\_

**Figure 34-3** Algorithm for treatment of acute asthma symptoms. PEF – peak expiratory flow, ED – emergency department, PCP – primary care physician. (Courtesy of BJC Health System/Washington University School of Medicine, Community Asthma Program, January 2000.)

## KEY REFERENCES

1. Moorman JE, Akinbami LJ, Bailey CM, Zahran HS, King ME, Johnson CA, et al. National surveillance of asthma: United States, 2001–2010. *Vital Health Stat 3* 2012;35:1–67.
7. Dijk FN, de Jongste JC, Postma DS, Koppelman GH. Genetics of onset of asthma. *Curr Opin Allergy Clin Immunol* 2013;13:193–202.
18. Meyers DA, Bleecker ER, Holloway JW, Holgate ST. Asthma genetics and personalised medicine. *Lancet Respir Med* 2014;2:405–15.
42. Yong SB, Wu CC, Wang L, Yang KD. Influence and mechanisms of maternal and infant diets on the development of childhood asthma. *Pediatr Neonatol* 2013;54:5–11.
47. Tai A, Tran H, Roberts M, Clarke N, Gibson AM, Vidmar S, et al. Outcomes of childhood asthma to the age of 50 years. *J Allergy Clin Immunol* 2014;133:1572–8 e3.
79. Nelson HS, Szefer SJ, Jacobs J, Huss K, Shapiro G, Sternberg AL. The relationships among environmental allergen sensitization, allergen exposure, pulmonary function, and bronchial hyperresponsiveness in the Childhood Asthma Management Program. *J Allergy Clin Immunol* 1999;104:775–85.
115. Strunk RC, Sternberg AL, Szefer SJ, Zeiger RS, Bender B, Tonascia J, et al. Long-term budesonide or nedocromil treatment, once discontinued, does not alter the course of mild to moderate asthma in children and adolescents. *J Pediatr* 2009;154:682–7.
124. Kelly HW, Sternberg AL, Lescher R, Fuhlbrigge AL, Williams P, Zeiger RS, et al. Effect of inhaled glucocorticoids in childhood on adult height. *N Engl J Med* 2012;367:904–12.
138. Lemanske RF Jr, Mauger DT, Sorkness CA, Jackson DJ, Boehmer SJ, Martinez FD, et al. Step-up therapy for children with uncontrolled asthma receiving inhaled corticosteroids. *N Engl J Med* 2010;362:975–85.
155. Busse W, Corren J, Lanier BQ, McAlary M, Fowler-Taylor A, Cioppa GD, et al. Omalizumab, anti-IgE recombinant humanized monoclonal antibody, for the treatment of severe allergic asthma. *J Allergy Clin Immunol* 2001;108:184–90.

## REFERENCES

- Moorman JE, Akinbami LJ, Bailey CM, Zahran HS, King ME, Johnson CA, et al. National surveillance of asthma: United States, 2001–2010. *Vital Health Stat 3* 2012;35:1–67.
- Moorman JE, Rudd RA, Johnson CA, King M, Minor P, Bailey C, et al. National surveillance for asthma – United States, 1980–2004. *MMWR Surveill Summ* 2007;56:1–54.
- von Mutius E. Allergies, infections and the hygiene hypothesis – the epidemiological evidence. *Immunobiology* 2007;212:433–9.
- Mandhane PJ, Greene JM, Cowan JO, Taylor DR, Sears MR. Sex differences in factors associated with childhood- and adolescent-onset wheeze. *Am J Respir Crit Care Med* 2005;172:45–54.
- Call RS, Smith TF, Morris E, Chapman MD, Platts-Mills TA. Risk factors for asthma in inner city children. *J Pediatr* 1992;121:862–6.
- Litonjua AA, Carey VJ, Weiss ST, Gold DR. Race, socioeconomic factors, and area of residence are associated with asthma prevalence. *Pediatr Pulmonol* 1999;28:394–401.
- Dijk FN, de Jongste JC, Postma DS, Koppelman GH. Genetics of onset of asthma. *Curr Opin Allergy Clin Immunol* 2013;13:193–202.
- Vercelli D. Discovering susceptibility genes for asthma and allergy. *Nat Rev Immunol* 2008;8:169–82.
- Williams H, McNicol KN. Prevalence, natural history, and relationship of wheezy bronchitis and asthma in children. An epidemiological study. *Br Med J* 1969;4:321–5.
- Castro-Rodriguez JA, Holberg CJ, Wright AL, Martinez FD. A clinical index to define risk of asthma in young children with recurrent wheezing. *Am J Respir Crit Care Med* 2000;162:1403–6.
- Celedon J, Palmer L, Weiss S, Wang B, Fand Z, Xu X. Asthma, rhinitis, and skin test reactivity to aeroallergens in families of asthmatic subjects in Anqing, China. *Am J Respir Crit Care Med* 2001;163:1108–12.
- Christie GL, Helms PJ, Godden DJ, Ross SJ, Friend JA, Legge JS, et al. Asthma, wheezy bronchitis, and atopy across two generations. *Am J Respir Crit Care Med* 1999;159:125–9.
- von Mutius E, Weiland SK, Fritzsche C, Duhme H, Keil U. Increasing prevalence of hay fever and atopy among children in Leipzig, East Germany. *Lancet* 1998;351:862–6.
- von Mutius E, Martinez FD. Epidemiology of childhood asthma. In: Murphy S, Kelly H, editors. *Pediatric asthma*. New York: Marcel Dekker, Inc; 1999. p. 363–431.
- Strachan DP. Hay fever, hygiene, and household size. *BMJ* 1989;299:1259–60.
- Weiss ST. Gene by environment interaction and asthma. *Clin Exp Allergy* 1999;29(Suppl. 2):96–9.
- Sexton K, Gong H Jr, Bailar JC 3rd, Ford JG, Gold DR, Lambert WE, et al. Air pollution health risks: do class and race matter? *Toxicol Ind Health* 1993;9:843–78.
- Meyers DA, Bleecker ER, Holloway JW, Holgate ST. Asthma genetics and personalised medicine. *Lancet Respir Med* 2014;2:405–15.
- Liggett SB. The pharmacogenetics of beta2-adrenergic receptors: relevance to asthma. *J Allergy Clin Immunol* 2000;105:S487–92.
- Strunk R, Mrazek D, Fuhrmann G, LaBrecque J. Physiologic and psychological characteristics associated with deaths due to asthma in childhood. A case-controlled study. *JAMA* 1985;254:1193–8.
- Klinnert MD, Nelson HS, Price MR, Adinoff AD, Leung DY, Mrazek DA. Onset and persistence of childhood asthma: predictors from infancy. *Pediatrics* 2001;108:E69.
- Sandberg S, Paton JY, Ahola S, McCann DC, McGuinness D, Hillary CR, et al. The role of acute and chronic stress in asthma attacks in children. *Lancet* 2000;356:982–7.
- Chen E, Hanson MD, Paterson LQ, Griffin MJ, Walker HA, Miller GE. Socioeconomic status and inflammatory processes in childhood asthma: the role of psychological stress. *J Allergy Clin Immunol* 2006;117:1014–20.
- Wright RJ, Finn P, Contreras JP, Cohen S, Wright RO, Staudenmayer J, et al. Chronic caregiver stress and IgE expression, allergen-induced proliferation, and cytokine profiles in a birth cohort predisposed to atopy. *J Allergy Clin Immunol* 2004;113:1051–7.
- Bussing R, Burket RC, Kelleher ET. Prevalence of anxiety disorders in a clinic-based sample of pediatric asthma patients. *Psychosomatics* 1996;37:108–15.
- Meijer AM, Griffioen RW, van Nierop JC, Oppenheimer L. Intractable or uncontrolled asthma: psychosocial factors. *J Asthma* 1995;32:265–74.
- Chen E, Matthews KA. Cognitive appraisal biases: an approach to understanding the relation between socioeconomic status and cardiovascular reactivity in children. *Ann Behav Med* 2001;23:101–11.
- Beuther DA, Sutherland ER. Overweight, obesity, and incident asthma: a meta-analysis of prospective epidemiologic studies. *Am J Respir Crit Care Med* 2007;175:661–6.
- Sin DD, Sutherland ER. Obesity and the lung: 4. Obesity and asthma. *Thorax* 2008;63:1018–23.
- Celedon JC, Palmer LJ, Litonjua AA, Weiss ST, Wang B, Fang Z, et al. Body mass index and asthma in adults in families of subjects with asthma in Anqing, China. *Am J Respir Crit Care Med* 2001;164:1835–40.
- Castro-Rodriguez JA, Holberg CJ, Morgan WJ, Wright AL, Martinez FD. Increased incidence of asthmatic symptoms in girls who become overweight or obese during the school years. *Am J Respir Crit Care Med* 2001;163:1344–9.
- Shaheen SO, Sterne JAC, Montgomery SM, Azima H. Birth weight, body mass index and asthma in young adults. *Thorax* 1999;54:396–402.
- He QQ, Wong TW, Du L, Jiang ZQ, Qiu H, Gao Y, et al. Respiratory health in overweight and obese Chinese children. *Pediatr Pulmonol* 2009;44:997–1002.
- Sah PK, Gerald Teague W, Demuth KA, Whitlock DR, Brown SD, Fitzpatrick AM. Poor asthma control in obese children may be overestimated because of enhanced perception of dyspnea. *J Allergy Clin Immunol Pract* 2013;1:39–45.
- Johnston SL, Pattemore PK, Sanderson G, Smith S, Lampe F, Josephs L, et al. Community study of role of viral infections in exacerbations of asthma in 9–11 year old children [see comments]. *BMJ* 1995;310:1225–9.
- Mok JY, Simpson H. Symptoms, atopy, and bronchial reactivity after lower respiratory infection in infancy. *Arch Dis Child* 1984;59:299–305.
- Sigurs N, Bjarnason R, Sigurbergsson F, Kjellman B, Bjorksten B. Asthma and immunoglobulin E antibodies after respiratory syncytial virus bronchiolitis: a prospective cohort study with matched controls. *Pediatrics* 1995;95:500–5.
- Sigurs N, Gustafsson PM, Bjarnason R, Lundberg F, Schmidt S, Sigurbergsson F, et al. Severe respiratory syncytial virus bronchiolitis in infancy and asthma and allergy at age 13. *Am J Respir Crit Care Med* 2005;171:137–41.
- Bacharier LB, Cohen R, Schweiger T, Yin-Declue H, Christie C, Zheng J, et al. Determinants of asthma after severe respiratory syncytial virus bronchiolitis. *J Allergy Clin Immunol* 2012;130:91–100 e3.
- Sigurs N, Aljassim F, Kjellman B, Robinson PD, Sigurbergsson F, Bjarnason R, et al. Asthma and allergy patterns over 18 years after severe RSV bronchiolitis in the first year of life. *Thorax* 2010;65:1045–52.
- Jackson DJ, Gangnon RE, Evans MD, Roberg KA, Anderson EL, Pappas TE, et al. Wheezing rhinovirus illnesses in early life predict asthma development in high-risk children. *Am J Respir Crit Care Med* 2008;178:667–72.
- Yong SB, Wu CC, Wang L, Yang KD. Influence and mechanisms of maternal and infant diets on the development of childhood asthma. *Pediatr Neonatol* 2013;54:5–11.
- Camargo CA Jr, Rifas-Shiman SL, Litonjua AA, Rich-Edwards JW, Weiss ST, Gold DR, et al. Maternal intake of vitamin D during pregnancy and risk of recurrent wheeze in children at 3 y of age. *Am J Clin Nutr* 2007;85:788–95.
- Devereux G, Litonjua AA, Turner SW, Craig LC, McNeill G, Martindale S, et al. Maternal vitamin D intake during pregnancy and early childhood wheezing. *Am J Clin Nutr* 2007;85:853–9.
- McKeever TM, Scrivener S, Broadfield E, Jones Z, Britton J, Lewis SA. Prospective study of diet and decline in lung function in a general population. *Am J Respir Crit Care Med* 2002;165:1299–303.
- Fogarty A, Lewis S, Weiss S, Britton J. Dietary vitamin E, IgE concentrations, and atopy. *Lancet* 2000;356:1573–4.
- Tai A, Tran H, Roberts M, Clarke N, Gibson AM, Vidmar S, et al. Outcomes of childhood asthma to the age of 50 years. *J Allergy Clin Immunol* 2014;133:1572–8 e3.
- Kelly W, Hudson I, Phelan P, Pain M, Olinsky A. Childhood asthma in adult life: a further study at 28 years of age. *Br Med J* 1987;294:1059–62.
- Roorda RJ, Gerritsen J, Van Aalderen WM, Schouten JP, Veltman JC, Weiss ST, et al. Risk factors for the persistence of respiratory symptoms in childhood asthma. *Am Rev Respir Dis* 1993;148:1490–5.
- Gold D, Wypij D, Wang X, Speizer F, Pugh M, Ware J, et al. Gender- and race-specific effects of asthma and wheeze on level and growth of lung function in children in sex U.S. cities. *Am J Respir Crit Care Med* 1994;149:1198–208.
- Blackhall MI. Ventilatory function in subjects with childhood asthma who have become symptom free. *Arch Dis Child* 1970;45:363–6.
- Grohl MH, Gerritsen J, Vonk JM, Schouten JP, Koeter GH, Rijcken B, et al. Risk factors for



- growth and decline of lung function in asthmatic individuals up to age 42 years. A 30-year follow-up study. *Am J Respir Crit Care Med* 1999;160:1830–7.
53. Oswald H, Phelan PD, Lanigan A, Hibbert M, Carlin JB, Bowes G, et al. Childhood asthma and lung function in mid-adult life. *Pediatr Pulmonol* 1997;23:14–20.
  54. Lange P, Parner J, Vestbo J, Schnohr P, Jensen G. A 15-year follow-up study of ventilatory function in adults with asthma. *N Engl J Med* 1998;339:1194–200.
  55. Zeiger R, Dawson C, Weiss S, Group CAMPCR. Relationships between duration of asthma and asthma severity among children in the Childhood Asthma Management Program (CAMP). *J Allergy Clin Immunol* 1999;103:376–87.
  56. Weiss ST, Van Natta ML, Zeiger RS. Relationship between increased airway responsiveness and asthma severity in the childhood asthma management program. *Am J Respir Crit Care Med* 2000;162:50–6.
  57. Bloomberg G, Goodman G, Fisher E, Strunk R. The profile of single admissions and readmissions for childhood asthma over a five year period at St. Louis Children's Hospital. *J Allergy Clin Immunol* 1997;99:S69.
  58. Chen E, Bloomberg G, Fisher E, Strunk R. Predictors to repeat hospitalizations in children with asthma: the role of psychosocial and socio-environmental factors. *Health Psychol* 2003;22:12–8.
  59. Strunk RC, Nicklas R, Milgrom H, Davis M, Ikle D. Risk factors for fatal asthma. In: Sheffer A, editor. *Fatal asthma*. New York: Marcel Dekker, Inc; 1998. p. 31–44.
  60. Liu AH, Zeiger R, Sorkness C, Mahr T, Ostrom N, Burgess S, et al. Development and cross-sectional validation of the Childhood Asthma Control Test. *J Allergy Clin Immunol* 2007;119:817–25.
  61. Nathan RA, Sorkness CA, Kosinski M, Schatz M, Li JT, Marcus P, et al. Development of the asthma control test: a survey for assessing asthma control. *J Allergy Clin Immunol* 2004;113:59–65.
  62. Galant SP, Morpew T, Amaro S, Liao O. Value of the bronchodilator response in assessing controller naive asthmatic children. *J Pediatr* 2007;151:457–62, 62 e1.
  63. Tse SM, Gold DR, Sordillo JE, Hoffman EB, Gillman MW, Rifas-Shiman SL, et al. Diagnostic accuracy of the bronchodilator response in children. *J Allergy Clin Immunol* 2013;132:554–9, e5.
  64. Miller RD, Hyatt RE. Evaluation of obstructing lesions of the trachea and larynx by flow-volume loops. *Am Rev Respir Dis* 1973;108:475–81.
  65. Crapo RO. Pulmonary-function testing. *N Engl J Med* 1994;331:25–30.
  66. Payne DN, Adcock IM, Wilson NM, Oates T, Scallan M, Bush A. Relationship between exhaled nitric oxide and mucosal eosinophilic inflammation in children with difficult asthma, after treatment with oral prednisolone. *Am J Respir Crit Care Med* 2001;164:1376–81.
  67. Jatakanon A, Lim S, Kharitonov SA, Chung KF, Barnes PJ. Correlation between exhaled nitric oxide, sputum eosinophils, and methacholine responsiveness in patients with mild asthma. *Thorax* 1998;53:91–5.
  68. Strunk RC, Szeffler SJ, Phillips BR, Zeiger RS, Chinchilli VM, Larsen G, et al. Relationship of exhaled nitric oxide to clinical and inflammatory markers of persistent asthma in children. *J Allergy Clin Immunol* 2003;112:883–92.
  69. Jones SL, Kittelson J, Cowan JO, Flannery EM, Hancox RJ, McLachlan CR, et al. The predictive value of exhaled nitric oxide measurements in assessing changes in asthma control. *Am J Respir Crit Care Med* 2001;164:738–43.
  70. Kharitonov SA, Donnelly LE, Montuschi P, Corradi M, Collins JV, Barnes PJ. Dose-dependent onset and cessation of action of inhaled budesonide on exhaled nitric oxide and symptoms in mild asthma. *Thorax* 2002;57:889–96.
  71. Beck-Ripp J, Griese M, Arenz S, Koring C, Pasqualoni B, Bufler P. Changes of exhaled nitric oxide during steroid treatment of childhood asthma. *Eur Respir J* 2002;19:1015–19.
  72. Sorkness CA, Lemanske RF Jr, Mauger DT, Boehmer SJ, Chinchilli VM, Martinez FD, et al. Long-term comparison of 3 controller regimens for mild-moderate persistent childhood asthma: the Pediatric Asthma Controller Trial. *J Allergy Clin Immunol* 2007;119:64–72.
  73. Straub DA, Minocchieri S, Moeller A, Hamacher J, Wildhaber JH. The effect of montelukast on exhaled nitric oxide and lung function in asthmatic children 2 to 5 years old. *Chest* 2005;127:509–14.
  74. Montuschi P, Mondino C, Koch P, Ciabattini G, Barnes PJ, Baviera G. Effects of montelukast treatment and withdrawal on fractional exhaled nitric oxide and lung function in children with asthma. *Chest* 2007;132:1876–81.
  75. Bratton DL, Lanz MJ, Miyazawa N, White CW, Silkoff PE. Exhaled nitric oxide before and after montelukast sodium therapy in school-age children with chronic asthma: a preliminary study. *Pediatr Pulmonol* 1999;28:402–7.
  76. Rosenstreich DL, Eggleston P, Kattan M, Baker D, Slavin RG, Gergen P, et al. The role of cockroach allergy and exposure to cockroach allergen in causing morbidity among inner-city children with asthma. *N Engl J Med* 1997;336:1356–63.
  77. Downs SH, Mitakakis TZ, Marks GB, Car NG, Belousova EG, Leuppi JD, et al. Clinical importance of Alternaria exposure in children. *Am J Respir Crit Care Med* 2001;164:455–9.
  78. O'Hollaren M, Yuninger J, Offord K, Somers M, O'Connell E, Ballard D, et al. Exposure to an aeroallergen as a possible precipitating factor in respiratory arrest in young patients with asthma. *New Engl J Med* 1991;324:359–63.
  79. Nelson HS, Szeffler SJ, Jacobs J, Huss K, Shapiro G, Sternberg AL. The relationships among environmental allergen sensitization, allergen exposure, pulmonary function, and bronchial hyperresponsiveness in the Childhood Asthma Management Program. *J Allergy Clin Immunol* 1999;104:775–85.
  80. Sears M, Burrows B, Flannery E, Herbison G, Hewitt C, Holdaway M. Relation between airway responsiveness and serum IgE in children with asthma and in apparently normal children. *N Engl J Med* 1991;325:1067–71.
  81. Burrows B, Sears M, Flannery E, Herbison G, Holdaway M, Silva P. Relation of the course of bronchial responsiveness from age 9 to age 15 to allergy. *Am J Respir Crit Care Med* 1995;152:1302–8.
  82. Dharmage S, Bailey M, Raven J, Mitakakis T, Cheng A, Guest D, et al. Current indoor allergen levels of fungi and cats, but not house dust mites, influence allergy and asthma in adults with high dust mite exposure. *Am J Respir Crit Care Med* 2001;164:65–71.
  83. Strunk RC, Sternberg A, Bacharier LB, Szeffler S, Group CAMPR. Nocturnal awakening due to asthma in children with mild to moderate asthma in the Childhood Asthma Management Program. *J Allergy Clin Immunol* 2002;110:395–403.
  84. Nafstad P, Magnus P, Gaarder PI, Jaakkola JJ. Exposure to pets and atopy-related diseases in the first 4 years of life. *Allergy* 2001;56:307–12.
  85. Dekker C, Dales R, Bartlett S, Brunekreef B, Zwanenburg H. Childhood asthma and the indoor environment. *Chest* 1991;100:922–6.
  86. Leynaert B, Bousquet J, Neukirch C, Liard R, Neukirch F. Perennial rhinitis: an independent risk factor for asthma in nonatopic subjects: results from the European Community Respiratory Health Survey. *J Allergy Clin Immunol* 1999;104:301–4.
  87. Foresi A, Pelucchi A, Gherson G, Mastropasqua B, Chiapparino A, Testi R. Once daily intranasal fluticasone propionate (200 micrograms) reduces nasal symptoms and inflammation but also attenuates the increase in bronchial responsiveness during the pollen season in allergic rhinitis. *J Allergy Clin Immunol* 1996;98:274–82.
  88. Adams RJ, Fuhlbrigge AL, Finkelstein JA, Weiss ST. Intranasal steroids and the risk of emergency department visits for asthma. *J Allergy Clin Immunol* 2002;109:636–42.
  89. Crystal-Peters J, Neslusan C, Crown WH, Torres A. Treating allergic rhinitis in patients with comorbid asthma: the risk of asthma-related hospitalizations and emergency department visits. *J Allergy Clin Immunol* 2002;109:57–62.
  90. Rachelefsky GS, Katz RM, Siegel SC. Chronic sinus disease with associated reactive airway disease in children. *Pediatrics* 1984;73:526–9.
  91. Oliveira CA, Sole D, Nasipitz CK, Rachelefsky GS. Improvement of bronchial hyperresponsiveness in asthmatic children treated for concomitant sinusitis. *Ann Allergy Asthma Immunol* 1997;79:70–4.
  92. Harding SM. Gastroesophageal reflux and asthma: insight into the association. *J Allergy Clin Immunol* 1999;104:251–9.
  93. Martin ME, Grunstein MM, Larsen GL. The relationship of gastroesophageal reflux to nocturnal wheezing in children with asthma. *Ann Allergy* 1982;49:318–22.
  94. Writing Committee for the American Lung Association Asthma Clinical Research C, Holbrook JT, Wise RA, Gold BD, Blake K, Brown ED, et al. Lansoprazole for children with poorly controlled asthma: a randomized controlled trial. *JAMA* 2012;307:373–81.
  95. Cook DG, Strachan DP. Health effects of passive smoking: summary of effects of parental smoking on the respiratory health of children and implications for research. *Thorax* 1999;54:357–66.
  96. Gold DR, Wang X, Wypij D, Speizer FE, Ware JH, Dockery DW. Effects of cigarette smoking on lung function in adolescent boys and girls. *N Engl J Med* 1996;335:931–7.
  97. Bacharier LB, Strunk RC. Vocal cord dysfunction: a practical approach. *J Respir Dis Pediatr* 2001;3:42–8.
  98. Nolan PK, Chrysler M, Phillips G, Goodman D, Rusakow LS. Pulse oximetry coupled with spirometry in the emergency department helps

- differentiate an asthma exacerbation from possible vocal cord dysfunction. *Pediatr Pulmonol* 2007;42:605–9.
99. Komarow HD, Young M, Nelson C, Metcalfe DD. Vocal cord dysfunction as demonstrated by impulse oscillometry. *J Allergy Clin Immunol Pract* 2013;1:387–93.
  100. Strunk RC, Mrazek DA, Fukuhara JT, Master-son J, Ludwick SK, LaBrecque JF. Cardiovascular fitness in children with asthma correlates with psychologic functioning of the child. *Pediatrics* 1989;84:460–4.
  101. Gutstadt LB, Gillette JW, Mrazek DA, Fukuhara JT, LaBrecque JF, Strunk RC. Determinants of school performance in children with chronic asthma. *Am J Dis Child* 1989;143:471–5.
  102. Bender BG, Belleau L, Fukuhara JT, Mrazek DA, Strunk RC. Psychomotor adaptation in children with severe chronic asthma. *Pediatrics* 1987;79:723–7.
  103. Bender BG. Depression symptoms and substance abuse in adolescents with asthma. *Ann Allergy Asthma Immunol* 2007;99:319–24.
  104. Grus CL, Lopez-Hernandez C, Delamater A, Appelgate B, Brito A, Wurm G, et al. Parental self-efficacy and morbidity in pediatric asthma. *J Asthma* 2001;38:99–106.
  105. Clark N, Feldman C, Evans D. The impact of health education on frequency and cost of health care use by low income children with asthma. *J Allergy Clin Immunol* 1986;78:108–14.
  106. Janson S, Reed ML. Patients' perceptions of asthma control and impact on attitudes and self-management. *J Asthma* 2000;37:625–40.
  107. Bender B, Zhang L. Negative affect, medication adherence, and asthma control in children. *J Allergy Clin Immunol* 2008;122:490–5.
  108. Hakala K, Stenius-Aarniala B, Sovijarvi A. Effects of weight loss on peak flow variability, airways obstruction, and lung volumes in obese patients with asthma. *Chest* 2000;118:1315–21.
  109. Strunk RC, Mascia A, Lipkowitz M, Wolf S. Rehabilitation of a patient with asthma in the outpatient setting. *J Allergy Clin Immunol* 1991;87:601–11.
  110. Weiler J, Layton T, Hunt M. Asthma in United States Olympic athletes who participated in the 1996 Summer Games. *J Allergy Clin Immunol* 1998;102:722–6.
  111. Program NAEaP. Expert Panel Report III: guidelines for the diagnosis and management of asthma. Bethesda, MD: US Department of Health and Human Services; 2007.
  112. Bacharier L, Mauger D, Lemanske RJ, Schend V, Sorkness CA, Strunk RC. Classifying asthma severity in children – Is measuring lung function helpful? *J Allergy Clin Immunol* 2002;109:S266.
  113. Juniper EF, O'Byrne PM, Guyatt GH, Ferrie PJ, King DR. Development and validation of a questionnaire to measure asthma control. *Eur Respir J* 1999;14:902–7.
  114. Childhood Asthma Management Program Research Group. Long-term effects of budesonide or nedocromil in children with asthma. *N Engl J Med* 2000;343:1054–63.
  115. Strunk RC, Sternberg AL, Szefer SJ, Zeiger RS, Bender B, Tonascia J, et al. Long-term budesonide or nedocromil treatment, once discontinued, does not alter the course of mild to moderate asthma in children and adolescents. *J Pediatr* 2009;154:682–7.
  116. Zeiger RS, Szefer SJ, Phillips BR, Schatz M, Martinez FD, Chinchilli VM, et al. Response profiles to fluticasone and montelukast in mild-to-moderate persistent childhood asthma. *J Allergy Clin Immunol* 2006;117:45–52.
  117. Shapiro G, Bronsky EA, LaForce CF, Mendelson L, Pearlman D, Schwartz RH, et al. Dose-related efficacy of budesonide administered via a dry powder inhaler in the treatment of children with moderate to severe persistent asthma. *J Pediatr* 1998;132:976–82.
  118. Peden DB, Berger WE, Noonan MJ, Thomas MR, Hendricks VL, Hamedani AG, et al. Inhaled fluticasone propionate delivered by means of two different multidose powder inhalers is effective and safe in a large pediatric population with persistent asthma. *J Allergy Clin Immunol* 1998;102:32–8.
  119. Szefer SJ, Martin RJ, King TS, Boushey HA, Cherniack RM, Chinchilli VM, et al. Significant variability in response to inhaled corticosteroids for persistent asthma. *J Allergy Clin Immunol* 2002;109:410–18.
  120. Allen DB, Bronsky EA, LaForce CF, Nathan RA, Tinkelman DG, Vandewalker ML, et al. Growth in asthmatic children treated with fluticasone propionate. Fluticasone Propionate Asthma Study Group. *J Pediatr* 1998;132:472–7.
  121. Agertoft L, Pedersen S. Effect of long-term treatment with inhaled budesonide on adult height in children with asthma. *N Engl J Med* 2000;343:1064–9.
  122. Silverstein MD, Yunginger JW, Reed CE, Petterson T, Zimmerman D, Li JT, et al. Attained adult height after childhood asthma: effect of glucocorticoid therapy. *J Allergy Clin Immunol* 1997;99:466–74.
  123. Van Bever HP, Desager KN, Lijssens N, Weyler JJ, Du Caju MV. Does treatment of asthmatic children with inhaled corticosteroids affect their adult height? *Pediatr Pulmonol* 1999;27:369–75.
  124. Kelly HW, Sternberg AL, Lescher R, Fuhlbrigge AL, Williams P, Zeiger RS, et al. Effect of inhaled glucocorticoids in childhood on adult height. *N Engl J Med* 2012;367:904–12.
  125. Chrousos GP, Harris AG. Hypothalamic-pituitary-adrenal axis suppression and inhaled corticosteroid therapy. 2. Review of the literature. *Neuroimmunomodulation* 1998;5:288–308.
  126. Bacharier LB, Raissy HH, Wilson L, McWilliams B, Strunk RC, Kelly HW. Long-term effect of budesonide on hypothalamic-pituitary-adrenal axis function in children with mild to moderate asthma. *Pediatrics* 2004;113:1693–9.
  127. Kelly HW, Van Natta ML, Covar RA, Tonascia J, Green RP, Strunk RC, et al. Effect of long-term corticosteroid use on bone mineral density in children: a prospective longitudinal assessment in the childhood Asthma Management Program (CAMP) study. *Pediatrics* 2008;122:e53–61.
  128. Knorr B, Matz J, Bernstein JA, Nguyen H, Seidenberg BC, Reiss TF, et al. Montelukast for chronic asthma in 6- to 14-year-old children: a randomized, double-blind trial. Pediatric Montelukast Study Group. *JAMA* 1998;279:1181–6.
  129. Kemp JP, Dockhorn RJ, Shapiro GG, Nguyen HH, Reiss TF, Seidenberg BC, et al. Montelukast once daily inhibits exercise-induced bronchoconstriction in 6- to 14-year-old children with asthma. *J Pediatr* 1998;133:424–8.
  130. Simons FE, Villa JR, Lee BW, Teper AM, Lyttle B, Aristizabal G, et al. Montelukast added to budesonide in children with persistent asthma: a randomized, double-blind, crossover study. *J Pediatr* 2001;138:694–8.
  131. Phipatanakul W, Greene C, Downes SJ, Cronin B, Eller TJ, Schneider LC, et al. Montelukast improves asthma control in asthmatic children maintained on inhaled corticosteroids. *Ann Allergy Asthma Immunol* 2003;91:49–54.
  132. Pizzichini E, Leff JA, Reiss TF, Hendeles L, Boulet LP, Wei LX, et al. Montelukast reduces airway eosinophilic inflammation in asthma: a randomized, controlled trial. *Eur Respir J* 1999;14:12–18.
  133. Bisgaard H, Loland L, Oj JA. NO in exhaled air of asthmatic children is reduced by the leukotriene receptor antagonist montelukast. *Am J Respir Crit Care Med* 1999;160:1227–31.
  134. Hakim F, Vilozni D, Adler A, Livnat G, Tal A, Bentur L. The effect of montelukast on bronchial hyperreactivity in preschool children. *Chest* 2007;131:180–6.
  135. Calhoun WJ, Lavins BJ, Minkwitz MC, Evans R, Gleich GJ, Cohn J. Effect of zafirlukast (Accolate) on cellular mediators of inflammation: bronchoalveolar lavage fluid findings after segmental antigen challenge. *Am J Respir Crit Care Med* 1998;157:1381–9.
  136. Ostrom NK, Decotiis BA, Lincourt WR, Edwards LD, Hanson KM, Carranza Rosenzweig JR, et al. Comparative efficacy and safety of low-dose fluticasone propionate and montelukast in children with persistent asthma. *J Pediatr* 2005;147:213–20.
  137. Shrewsbury S, Pyke S, Britton M. Meta-analysis of increased dose of inhaled steroid or addition of salmeterol in symptomatic asthma (MIASMA). *BMJ* 2000;320:1368–73.
  138. Lemanske RF Jr, Mauger DT, Sorkness CA, Jackson DJ, Boehmer SJ, Martinez FD, et al. Step-up therapy for children with uncontrolled asthma receiving inhaled corticosteroids. *N Engl J Med* 2010;362:975–85.
  139. Zimmerman B, D'Urzo A, Berube D. Efficacy and safety of formoterol Turbuhaler when added to inhaled corticosteroid treatment in children with asthma. *Pediatr Pulmonol* 2004;37:122–7.
  140. Verberne AA, Frost C, Duiverman EJ, Grol MH, Kerrebijn KF. Addition of salmeterol versus doubling the dose of beclomethasone in children with asthma. The Dutch Asthma Study Group. *Am J Respir Crit Care Med* 1998;158:213–19.
  141. Fowler SJ, Currie GP, Lipworth BJ. Step-down therapy with low-dose fluticasone-salmeterol combination or medium-dose hydrofluoralkane 134a-beclomethasone alone. *J Allergy Clin Immunol* 2002;109:929–35.
  142. Ni Chroinin M, Lasserson TJ, Greenstone I, Ducharme FM. Addition of long-acting beta-agonists to inhaled corticosteroids for chronic asthma in children. *Cochrane Database Syst Rev* 2009;CD007949.
  143. Tasche MJ, Uijen JH, Bernsen RM, de Jongste JC, van der Wouden JC. Inhaled disodium cromoglycate (DSCG) as maintenance therapy in children with asthma: a systematic review. *Thorax* 2000;55:913–20.
  144. Brenner M, Berkowitz R, Marshall N, Strunk RC. Need for theophylline in severe steroid-requiring asthmatics. *Clin Allergy* 1988;18:143–50.

145. Baba K, Sakakibara A, Yagi T, Niwa S, Hattori T, Koishikawa I, et al. Effects of theophylline withdrawal in well-controlled asthmatics treated with inhaled corticosteroid. *J Asthma* 2001;38:615–24.
146. Bender BG, Ikle DN, DuHamel T, Tinkelman D. Neuropsychological and behavioral changes in asthmatic children treated with beclomethasone dipropionate versus theophylline. *Pediatrics* 1998;101:355–60.
147. Bousquet J. Pro: immunotherapy is clinically indicated in the management of allergic asthma. *Am J Respir Crit Care Med* 2001;164:2139–40, discussion 41–2.
148. Adkinson NF Jr. Con: immunotherapy is not clinically indicated in the management of allergic asthma. *Am J Respir Crit Care Med* 2001;164:2140–1, discussion 1–2.
149. Cox L, Nelson H, Lockey R, Calabria C, Chacko T, Finegold I, et al. Allergen immunotherapy: a practice parameter third update. *J Allergy Clin Immunol* 2011;127:S1–55.
150. Kim JM, Lin SY, Suarez-Cuervo C, Chelladurai Y, Ramanathan M, Segal JB, et al. Allergen-specific immunotherapy for pediatric asthma and rhinoconjunctivitis: a systematic review. *Pediatrics* 2013;131:1155–67.
151. Fitzpatrick AM, Gaston BM, Erzurum SC, Teague WG, National Institutes of Health/National Heart L, Blood Institute Severe Asthma Research P. Features of severe asthma in school-age children: atopy and increased exhaled nitric oxide. *J Allergy Clin Immunol* 2006;118:1218–25.
152. Kattan M, Mitchell H, Eggleston P, Gergen P, Crain E, Redline S, et al. Characteristics of inner-city children with asthma: the National Cooperative Inner-City Asthma Study. *Pediatr Pulmonol* 1997;24:253–62.
153. Moller C, Dreborg S, Ferdousi HA, Halken S, Host A, Jacobsen L, et al. Pollen immunotherapy reduces the development of asthma in children with seasonal rhinoconjunctivitis (the PAT-study). *J Allergy Clin Immunol* 2002;109:251–6.
154. Berger W, Gupta N, McAlary M, Fowler-Taylor A. Evaluation of long-term safety of the anti-IgE antibody, omalizumab, in children with allergic asthma. *Ann Allergy Asthma Immunol* 2003;91:182–8.
155. Busse W, Corren J, Lanier BQ, McAlary M, Fowler-Taylor A, Cioppa GD, et al. Omalizumab, anti-IgE recombinant humanized monoclonal antibody, for the treatment of severe allergic asthma. *J Allergy Clin Immunol* 2001;108:184–90.
156. Milgrom H, Berger W, Nayak A, Gupta N, Pollard S, McAlary M, et al. Treatment of childhood asthma with anti-immunoglobulin E antibody (omalizumab). *Pediatrics* 2001;108:E36.
157. Lemanske RF Jr, Nayak A, McAlary M, Everhard F, Fowler-Taylor A, Gupta N. Omalizumab improves asthma-related quality of life in children with allergic asthma. *Pediatrics* 2002;110:e55.
158. Gawchik SM, Saccar CL, Noonan M, Reasner DS, DeGraw SS. The safety and efficacy of nebulized levalbuterol compared with racemic albuterol and placebo in the treatment of asthma in pediatric patients. *J Allergy Clin Immunol* 1999;103:615–21.
159. Martinati LC, Boner AL. Anticholinergic anti-muscarinic agents in the treatment of airways bronchoconstriction in children. *Allergy* 1996;51:2–7.
160. Qureshi F, Pestian J, Davis P, Zaritsky A. Effect of nebulized ipratropium on the hospitalization rates of children with asthma. *N Engl J Med* 1998;339:1030–5.
161. Zorc JJ, Pusic MV, Ogborn CJ, Lebet R, Duggan AK. Ipratropium bromide added to asthma treatment in the pediatric emergency department. *Pediatrics* 1999;103:748–52.
162. Scarfone RJ, Fuchs SM, Nager AL, Shane SA. Controlled trial of oral prednisone in the emergency department treatment of children with acute asthma. *Pediatrics* 1993;92:513–18.
163. Becker JM, Arora A, Scarfone RJ, Spector ND, Fontana-Penn ME, Gracely E, et al. Oral versus intravenous corticosteroids in children hospitalized with asthma. *J Allergy Clin Immunol* 1999;103:586–90.
164. Covar RA, Leung DY, McCormick D, Steelman J, Zeidler P, Spahn JD. Risk factors associated with glucocorticoid-induced adverse effects in children with severe asthma. *J Allergy Clin Immunol* 2000;106:651–9.
165. Grant CC, Duggan AK, Santosham M, DeAngelis C. Oral prednisone as a risk factor for infections in children with asthma. *Arch Pediatr Adolesc Med* 1996;150:58–63.
166. Childhood Asthma Management Program Research Group. The Childhood Asthma Management Program (CAMP): design, rationale, and methods. Childhood Asthma Management Program Research Group. *Control Clin Trials* 1999;20:91–120.

# School-Centered Asthma Programs

LISA CICUTTO

## KEY POINTS

- High rates of school absenteeism affect a child's ability to learn. Every school day in the USA 36,000 children and youth miss school because of asthma.
- Asthma has the potential to affect academic performance, starting at a young age.
- Several school-centered models have been evaluated and demonstrated benefits in asthma-related outcomes. Evaluated activities include asthma screening, asthma case identification, supervised administration of maintenance asthma medication, case management, care coordination among students, families, healthcare providers and schools, self-management asthma education programs, creating asthma friendly and supportive schools, and asthma care programs delivered through school-based health clinics.
- Asthma management at schools is important for pediatric pulmonologists and allergists, pediatricians, family care providers, and healthcare professionals providing quality asthma care. The variability of asthma care practices makes it necessary for clinicians to learn what is happening at their patients' schools and to advocate for appropriate services.

## Introduction

Asthma is a common chronic childhood condition associated with significant morbidity, high rates of school absenteeism, and excessive costs for the individual and society. Every school day in the USA 36,000 children and youths miss school because of asthma.<sup>1</sup> High rates of school absenteeism affect a child's ability to learn. A healthy student with well-controlled asthma is a student ready to learn and to be a full participant in the school experience, including physical activity and sports.

The history of asthma programs in schools dates back about 30 years; thus, a significant body of literature exists that has evaluated a variety of strategies directed at improving overall asthma management in order to reduce asthma-associated morbidity. The purpose of this chapter is to review the literature in terms of the rationale for school-centered interventions, barriers identified in school settings, strategies implemented and evaluated, strengths and limitations of the literature, future directions for research and how asthma care providers can be effective team players.

## Why Center on Schools?

As mentioned, asthma is a leading cause of school absenteeism, but this is not equally distributed among those with asthma.<sup>2</sup>

School absenteeism is associated with family income. Recent research highlights that students attending schools with the highest proportions of low-income students were more likely to miss school because of asthma.<sup>3</sup> Additional risk factors for high absenteeism rates included younger age, frequent experience of asthma symptoms and/or using asthma medications.

Asthma has the potential to affect academic performance, starting at a young age. A prospective cohort study in New Zealand observed that entering school with asthma was associated with low academic achievement.<sup>4</sup> Entering school with asthma reliably predicted low reading level achievement independent of known co-variables such as high absenteeism, minority status, male gender, single-parent family, low socioeconomic status and poor academic skills at school entry. Data from the U.S. National Interview Survey noted that children with asthma missed three times more school and had a 1.7 times greater risk of having a learning disability compared to well children.<sup>5</sup>

Basch<sup>6</sup> expanded our understanding of this area with a systematic review that identified that asthma directly and indirectly affects academic achievement of school-aged youth. The results of this study indicated that asthma affects the student's motivation to learn. Identified causal pathways that could affect academic achievement included cognition, high absenteeism, school connectedness and dropping out.<sup>6</sup> Asthma and the causal pathways have interactive and synergistic effects that represent a complex situation that must be addressed collectively through a coordinated and partnered approach. Taken together, this work suggests the need for school-level interventions to decrease asthma-related absenteeism, especially in schools with a high proportion of low-income families.

Partnering with schools provides opportunities to reach most children with asthma and those at the highest-risk of asthma burden in need of assistance. Because schools provide reliable access for reaching large numbers of children with asthma, they have become a targeted setting for quality asthma care programs and initiatives. In addition, schools are often the only setting of affordable health care for low income and ethnic minority youth because of limited access to medical care. Schools are often advocated as the ideal setting for health education, health services and the development of supportive networks and collaborations. Accordingly, school settings are ideal settings for reaching high-risk children and youth with asthma and for reducing asthma health disparities. Several school-centered models have been evaluated and have included a variety and combination of activities: asthma screening, asthma case identification, supervised administration of maintenance asthma medication, case management, care coordination among students, families, healthcare providers and schools, self-management asthma education programs, creating asthma friendly and supportive schools, and asthma care programs delivered through school-based health clinics.



## Asthma Management Challenges in Schools

### INSUFFICIENT HEALTH TEAM STAFFING AT SCHOOLS

Although school settings have several advantages over clinic settings in providing asthma care, there are several distinct challenges that must be considered. Given the prevalence of asthma and the shortage of health personnel in schools, it is not surprising that once students are identified as having asthma, schools lack the facilities for appropriate evaluation and treatment. A US national survey conducted as part of the School Health Policies and Programs Study revealed that only 36% of schools had a full-time school nurse and that only 19% of health coordinators in the school setting received professional development for asthma care,<sup>7</sup> suggesting that not only do schools have a shortage of health personnel, but that these personnel also have significant knowledge gaps in asthma care. A survey of parents confirmed that learning gaps exist for school personnel and parents expressed a desire for teachers and staff to have higher levels of knowledge and understanding to support their children.<sup>8</sup>

### POOR COMMUNICATION

A major obstacle to successful asthma management in schools is poor communication among students, families, healthcare providers and schools. Surveys and interviews with school nurses, school personnel, parents and healthcare providers identified communication as the greatest challenge.<sup>9,10</sup> Most parents of students with asthma never speak to the school nurse and too often school nurses learn of a student's diagnosis of asthma when he/she presents to the office with asthma symptoms and informs the nurse of the diagnosis.<sup>9</sup> Although all parties recognize that students require individualized instructions and information to support asthma management at school, this is not happening.<sup>10</sup> School nurses also identified the lack of parental support and involvement as a significant barrier to successful management. Often there is also role confusion and unclear policies and practices for managing asthma at schools that could be addressed through clearer communication by schools of existing policies and protocols. If asthma management is to improve, it is crucial that improvements in communication occur among these parties.

### School Asthma Care Plans and Easily Accessible Rescue Therapy

Two key elements for successful asthma management in school settings are (1) beginning the school year with a completed school asthma care plan and (2) an on-site quick relief inhaler that is preferably carried by the student. The purpose of the written asthma care plan is to outline asthma management steps at schools and to serve as a type of medical order for schools. It is required so that students experiencing symptoms can use their quick-acting inhaler kept at school to relieve symptoms quickly, thus enabling them to return to class and avoid having to leave the school for treatment or to wait in the nurse's office while a family member brings in the inhaler. Asthma care plans for schools differ from asthma action plans for home use in

several ways and therefore home plans may not be acceptable or sufficient for the school setting. Common problems of home-based asthma action plans are that they often lack a release for sharing health information among school personnel and the student's healthcare providers, and lack the signed indication from a parent/guardian and healthcare provider for self-carrying the inhaler or the need for assistance with medication administration. Additionally, because the action plan is seen as a medical order in schools, the inclusion of the use of maintenance asthma medication (typically containing an inhaled steroid) is problematic, as it is interpreted that the school nurse is required to administer the medication daily (often twice daily). This latter issue creates additional problems for the school in that it has insufficient personnel for daily, supervised, administration of maintenance asthma medications for all students with asthma and it requires reliance on families to supply schools with maintenance asthma medications as schools do not have funds to supply these medications. Often families have insufficient funds to purchase asthma maintenance medications for home use let alone funds to purchase extra medication to be kept at school; a steroid inhaler can cost hundreds of dollars.

Several studies highlight that these two crucial elements to successful asthma management in schools are not being fulfilled.<sup>11,12</sup> A recent study involving five Alabama school districts observed that not one student with physician-confirmed asthma had a complete school asthma care plan/action plan on file at the school. Reported rates of students with asthma having a quick-relief inhaler at school ranged from 14% to 39% of students with asthma.<sup>12,13</sup> This work suggests that the gap between policy and practice is dramatic and potentially life threatening. Federal laws exist and many states and school districts have legislation and policies in place permitting students to possess quick-relief inhalers and/or to receive support from school personnel in the storage and administration of the medication.<sup>14</sup> However, school district policies typically require completion of an asthma care plan for school or standard forms and authorizing signatures of students' parents/guardians and physicians/healthcare providers. A study in Minnesota developed and implemented a secure portal designed for the electronic exchange of an asthma action care plan between providers and schools. School nurses reported that this initiative resulted in more efficient asthma management and school nurse self-confidence in managing an individual student's asthma.<sup>15</sup> This type of intervention deserves additional investigation.

### Physical Activity at School

Most students with asthma report experiencing symptoms during physical activity at school, prompting them to initiate the self-care activities of sitting out the activity, visiting the school nurse and/or drinking water.<sup>16</sup> Barriers reported by students to participating in physical activity include the lack of a school asthma care plan or action plan detailing asthma management steps for physical activity, such as pre-treatment, lack of accessible quick-relief inhalers, poor asthma control, and stigma associated with symptoms caused by physical activity and with using asthma inhalers.<sup>16</sup> Most work in the area has been limited to describing the issue with little attention focused on increasing participation in physical activity in schools.

## School-Centered Implemented and Evaluated Strategies

Poor and minority children experience the greatest asthma morbidity and are also least likely to receive adequate asthma care.<sup>2</sup> As a way to target these high-risk children, school-centered asthma care management programs have been evaluated, mainly in inner cities. A variety of strategies have been evaluated and typically involve some degree of partnership among school personnel, community health providers and families. The types of direct services implemented and evaluated vary in strategy, targeted audiences for intervention and human resources for staffing the intervention. The focus of these interventions was to increase the quality of asthma care, but the process to achieve this goal varied from direct asthma service provision, case management and care coordination to asthma self-management educational programs and creating supportive school environments.

### HUMAN RESOURCE SUPPLEMENTATION OF THE SCHOOL HEALTH TEAM

To address the shortage of trained health professionals on site at schools, strategies evaluated have included adding physicians and other community healthcare providers, and extending the hours of school nurses to full-time. Although not evaluated through a controlled study, it was observed that a program that provided a consulting physician a half day per week to work with school nurses increased the delivery of quick-relief medications at school instead of home, which led to reductions in the number of students leaving school or requiring a 911 call for urgent care, thus keeping them engaged in school activities.<sup>17</sup> In a similar non-randomized controlled study, the same trend for a reduction in sending students home because of asthma was reported, although the difference was very small (13.8% vs 12.6%).<sup>18</sup> Similarly, in a quasi-experimental study, adding a full-time school nurse versus a part-time nurse (often 1 day/week) to care for students with asthma, improvements were noted: a decrease in absenteeism, fewer emergency department visits and cost savings.<sup>19</sup> Healthcare provider support can also be brought into the school through school-based health centers. These centers provide on-site care delivered by physicians, physician assistants or nurse practitioners for students at school. Two studies focusing on improving asthma care through school-based health clinics demonstrated improvements in the need for emergency department visits, hospitalizations and school absenteeism.<sup>20,21</sup> Bringing a mobile health clinic to the school to provide healthcare staff, diagnostics and regularly scheduled visits is an alternative strategy to improve asthma outcomes, again leading to improvements in reducing hospitalizations, emergency department visits, asthma symptoms, rescue inhaler use and school absenteeism.<sup>22–24</sup>

### DIRECTLY OBSERVED THERAPY

Several small and larger randomized controlled studies have evaluated the benefits of directly observed asthma maintenance therapy (primarily inhaled corticosteroids) by school nurses that involved the partnership and coordination of care among school nurses, primary care providers and families. The approach involved identifying students requiring daily maintenance asthma therapy, review and agreement of therapy and

dosages by both study physicians and students' physicians, and school nurse provision of daily maintenance controller therapy on school days. Because adherence to asthma medications is typically below 50%, it is an important factor in achieving asthma control. These studies have typically observed improvements in medication adherence and asthma-related outcomes such as symptoms-free days, asthma control, reduced number of exacerbations and school absenteeism.<sup>25–27</sup> In one of the larger randomized controlled studies, the improvements observed were marginal and not as consistent as in the other studies.<sup>27</sup> Similarly, one study only noted improvements in those not exposed to second-hand smoke.<sup>25</sup> An important consideration when determining the generalizability and application of this work is that the success of this intervention may be related to the study physicians supporting asthma guideline-recommended care and that supervised medication use may not have the desired benefit if the level of treatment is not consistent with the level of asthma control.

### CASE MANAGEMENT AND CARE COORDINATION

Case management involves spending time contacting and then patiently and persistently working with the family to build a trusting relationship. Care coordination services ensure timely, coordinated care to provide appropriate levels of health, psychosocial and support services, and continuity of care through ongoing assessment of the client's and family members' needs. Care coordination and case management activities include: an initial assessment of service needs; development of a comprehensive, individualized plan; coordination of services required to implement the plan; monitoring of the client and family to assess the plan's effectiveness; and re-evaluation and revision of the plan as necessary. Case management strategies applied through schools to higher risk students with asthma hold promise. Many of the school-centered interventions evaluated have included case management as an element of the intervention.<sup>13,19,22–31</sup> The case management activity most frequently reported was working with the family followed by contacting healthcare providers. Extensive care coordination and case management services are typically only needed by students who continue to experience poorly controlled asthma despite having the usual support systems. Benefits observed included improved asthma control, reduced use of healthcare services related to asthma exacerbations and reduced school absenteeism.<sup>13,19,22–31</sup> However, many of the studies highlighted that a great deal of effort is needed to engage the community asthma care providers.

## Information Technology Infrastructure

Information technology that permits data sharing is an important component of an infrastructure to promote coordination of care across schools, families and healthcare providers to achieve successful asthma management. A project in the Charlotte Mecklenburg Schools suggests that databases maintained by nurses, asthma program staff and school personnel can be successfully integrated into a single asthma program evaluation database. Benefits reported as a result of their shared database included an ability to identify students with an elevated level of

need in order to receive priority care status from the asthma education program, and an ability to evaluate program outcomes that were not possible before such as academic performance, school attendance, school behavior and quality of life.<sup>32</sup> Others have focussed on developing a web-based system to make previously evaluated effective programs that require intense study staff participation potentially sustainable and transferable because web-based systems are viewed as less expensive and more accessible. However, work is needed to determine if these assumptions are valid. A study in Denver Public Schools is currently underway to evaluate an asthma-specific tab as part of the district's electronic academic platform. This system includes monitoring receipt of a school asthma care/action plan, availability of an on-site quick-relief rescue inhaler, monitoring of at-risk asthma status, monitoring of school absenteeism, calculating the percentage of school absenteeism, tracking visits to the school health office for asthma, and 911 calls for asthma.<sup>30,33</sup> Studies are needed to evaluate the effectiveness and added value of information technology platforms that are intended to improve communication and coordination of care among schools, families and health-care providers, provide asthma care support to school nurses and promote sustainability, while reducing costs.

## Interventions to Improve Asthma Self-Management Skills

The National Heart, Lung and Blood Institute Expert Panel Guidelines for the Diagnosis and Management of Asthma stress the need for asthma education and the development of asthma management skills to achieve successful disease control.<sup>34</sup> A number of studies have assessed the effectiveness of providing asthma education in schools.<sup>31,35-45</sup> These educational programs incorporate health education theories and asthma practice guidelines. Most school-based educational programs have focussed on building skills for elementary school-aged children and have demonstrated improvements in asthma knowledge, confidence/self-efficacy, asthma management skills and associated asthma morbidity outcomes, such as improved quality of life, and reduced symptoms, emergency department visits, urgent care visits, hospitalizations and school absenteeism.<sup>31,35-45</sup> Some studies have extended these benefits to improvements in school grades and academic performance.<sup>37,38,44,45</sup>

Recently, school-centered asthma education efforts have targeted adolescents of low income living in urban settings.<sup>46-50</sup> Studies in adolescents, an identified difficult-to-reach group, have demonstrated acceptance, involvement and retention by this age group: over 75% of those eligible participated and over 70% were retained.<sup>46,47</sup> Benefits observed included improved self-confidence in asthma management skills, appropriate use of controller and quick-relief asthma medications, fewer days with symptoms and activity limitation, fewer interrupted nights due to asthma, decreased hospitalizations, emergency department visits, and school absenteeism, and improved quality of life.<sup>29,46-50</sup> Interventions are starting to address the complexity of and co-morbidities associated with asthma. A pilot study completed in Chicago high schools combined asthma management and nutrition and weight management for all students with asthma, regardless of weight.<sup>50</sup> The program consisted of nutrition and weight management, asthma education, a family

education event, and two-monthly reinforcement visits with behavioral counseling provided by a nurse and dietetic intern to increase asthma and nutrition knowledge, asthma and nutritional self-efficacy, asthma control and quality of life. Web-based asthma self-management programs have also been developed to attract and educate adolescents with asthma.<sup>29</sup> Puff City, a web-based tailored asthma intervention with a case manager, led to improved symptoms, restricted days and school absences; however, improvements in medical care were not observed. With the exception of a few studies,<sup>29,48,49</sup> this work was completed through non-randomized, controlled study designs with relatively short follow-up periods. This area is worthy of studies using more rigorous study designs.

Synthesizing findings in this area is difficult due to the heterogeneity of interventions, age of students, interventional populations and outcomes assessed. For instance, interventions varied in educational components, number and duration of sessions and personnel type. Target populations included exclusively students with asthma or these students in combination with one or more of the following groups: parents/guardians, healthcare providers, classmates and school personnel. Study personnel providing the intervention ranged from certified asthma educators to school nurses to health professional students to lay providers. Teaching modalities also varied from individualized one-on-one teaching to group teaching to computer-based programs. Although several randomized controlled trials have been conducted, limitations remain: studies do not clearly describe usual care; several studies included students with mild asthma and did not perform subgroup analyses to determine if asthma severity, asthma control, age, race/ethnicity, socioeconomic status or location (inner-city, suburban, city, rural) predicted interventional response; studies were often limited in their ability to draw conclusions about differences between comparison groups due to a lack of power with smaller sample sizes; and studies did not include a follow-up period to determine if improvements continue, are sustained or regress. Although results across studies have not been consistent, systematic reviews suggest that school-centered asthma education has positive clinical, humanistic, health, economic and academic outcomes.<sup>44,45</sup>

## Creating Asthma Friendly Schools

Asthma friendly schools are those that make the effort to create safe and supportive learning environments for students with asthma. Schools can create asthma friendly and supportive environments for learning and healthy development through the implementation of policies and protocols. [Table 35-1](#) identifies eight core elements and implementation tips for creating asthma friendly and supportive schools, taken from the work of several groups and organizations.<sup>11,51-56</sup>

In the USA, school nurse teams deliver most asthma care, although only one third of schools have a full-time nurse and one third have a full-time health paraprofessional. In the absence of health service staff, main office staff and teachers are required to manage flare-ups and medication administration. Deaths from asthma in schools may be attributed to delays in school personnel providing assistance.<sup>57</sup> Previous studies highlight inadequate asthma management practices in schools and asthma knowledge and skill gaps of school personnel.<sup>11,36,58-60</sup> Despite the importance of intervention from school staff, few interventions have targeted this important group.

**TABLE 35-1** Elements for Creating Asthma Friendly and Supportive Schools

Elements for Supportive Schools	Implementation Tips
Identify and know which students have asthma	School health registration forms should ask explicitly about whether or not the student has asthma and uses asthma medications Parents/guardians and students need to let schools know they are affected by asthma School-wide screening to identify new cases of asthma is discouraged
Provide easy access to quick-relief asthma inhalers	Most schools do not stock quick-relief inhalers for students' use, even for emergency use Families need to ensure that their children with asthma have a quick-relief inhaler at school at all times. Even when schools encourage self-carrying of inhalers, as few as 14% of students have access to a quick-relief inhaler at school <sup>27</sup> Know the school district form(s) that need to be completed and returned to ensure the student has easy access to his/her inhaler Ensure students with asthma know how to correctly use the inhaler, the importance of not sharing their inhaler and the responsibilities associated with self-carrying their inhaler
Ensure that school staff are prepared to identify and handle worsening asthma and asthma emergencies	Each student with asthma needs a completed and submitted up-to-date asthma care plan or action plan appropriate for his/her school district Schools should have a written protocol or plan for school staff to follow for identifying and responding to worsening asthma
Reduce exposure to environmental asthma triggers	Report asthma triggers on the individualized asthma care plan/action plan for school Develop and implement Indoor Air Quality Management program for schools ( <a href="http://www.epa.gov/iaq/schools/">www.epa.gov/iaq/schools/</a> ): <ul style="list-style-type: none"> <li>• Schools and grounds are smoke free at all times</li> <li>• Low scent and green products (cleaning, art supplies, etc.) are used</li> <li>• Integrated pest management practices are followed</li> </ul>
Facilitate full participation of students with asthma in all activities, including physical activity and play	Asthma should not be an excuse for not participating in gym class, sports or play during school recesses School asthma care plans/action plans typically have a section dedicated to delineating steps to take for supporting participation in physical activity and recess Clinicians need to ensure that students clearly understand the steps to take and that the plan is clearly communicated to the school to permit the student to be a full participant
Provide learning opportunities for students, parents/guardians and school staff	At least annual staff trainings are needed to review how to identify and respond to worsening asthma, accurately use asthma medications and manage asthma triggers in a school setting School nurse health teams often have 'teachable moment' opportunities during office visits for worsening asthma or pretreatment sessions to reinforce the same asthma control messages as the asthma care provider, and for assessing and coaching for accurate technique along with other asthma management education topics and skills Healthcare providers play an important role in providing educational opportunities for the school community including students, school personnel and parents
Coordinate and work with students, parents/guardians, healthcare professionals and community organizations to successfully manage asthma	A system exists for schools, families affected by asthma and healthcare providers to share information for keeping all parties informed. This system may be paper-based or electronic. Examples of system elements include: asthma care plans/action plans, alerts to healthcare providers and families when high rates of absenteeism have occurred, notifications to the family and healthcare provider related to excessive use of a rescue inhaler, and sharing discharge summaries with school nurses for urgent/emergency department visits and hospitalizations

Training school staff (administrators, secretaries, teachers, etc.) in the recognition of and appropriate response to worsening asthma and in asthma medications led to improvements in asthma knowledge and practice.<sup>36,61</sup> A randomized controlled study in 130 elementary schools evaluated a multifaceted intervention, 'The Creating Asthma Friendly Schools Resource Kit', which involved education of the entire school community, support for policy changes and resources for asthma friendly schools, and reported improvements in school practices that created supportive and asthma friendly school environments. Improvements were noted for asthma knowledge and skills of school personnel and students, the percentage of school staff that knew the students with asthma, the provision of easy access to inhalers with increases in students self-carrying their quick-relief inhaler, the existence and use of a school-wide process for managing worsening asthma, the implementation of strategies to reduce exposure to triggers and to permit students to be full participants at school, and the use of strategies to support communication among families, schools and asthma care

providers.<sup>36</sup> This work suggests that the potential benefit of interventions targets the whole school community; however, additional work to determine the effectiveness of such interventions is needed.

### Cost-Effectiveness of Strategies

Few school-centered studies have determined the cost-effectiveness of these types of interventions. A study by Noyes et al<sup>62</sup> demonstrated that their school-based supervised maintenance asthma therapy program could be economically effective for children aged 3–10 years in inner city schools: \$10 per one extra symptom-free day. The reported cost of the program was \$4,822 per 100 children, which included personnel costs. The program resulted in about \$3,000 in savings to schools and the healthcare system. They noted that limiting the program to students having the most persistent asthma symptoms increased the cost-effectiveness. Another study looking at cost-effectiveness of a school-based health center program noted that



medical savings alone could not offset the costs of implementing and sustaining an asthma prevention program. However, when savings due to reduction in parent opportunity costs and premature child deaths were considered, the benefits of the program far exceeded the costs.<sup>63</sup> As noted above, several studies in the school setting have demonstrated that case management, self-management and educational programs are effective. However, these programs cost money to implement and often result in higher medication costs owing to increased use of more expensive maintenance asthma inhalers, and more physician/healthcare provider visits for monitoring and follow-up. Information on the cost-effectiveness of school-centered interventions is severely limited, and requires additional study and reporting.

## How can Community Asthma Care Providers Be an Essential Part of the Team?

Asthma management at schools is important for pediatricians, family care providers, pediatric pulmonologists and allergists, and healthcare staff working with physicians to provide quality asthma care. The variability of asthma care services and programs that may or may not be provided in schools across the USA makes it necessary for clinicians to learn what is happening at their patients' schools and to advocate for appropriate services.

Asthma morbidity for children and youth can be significantly reduced through the coordinated efforts of asthma care providers, families and schools. Asthma care providers play a vital role in preparing and supporting children and youth with asthma and their families to manage asthma at school as part of the overall goal of achieving successful asthma control. Time is often limited for asthma care providers so it is important to know which actions will have the greatest benefits. [Table 35-2](#) summarizes the literature reviewed and existing resources to provide a list of 'best practice' action items and [Box 35-1](#) provide existing resources for busy asthma care providers.<sup>64-67</sup>

## Summary

Second to their home, youths spend the largest portions of their day at school and during the school year, the largest portion of their wakeful hours. The Centers for Disease Control (CDC) and multiple studies highlight the need for schools, youths with asthma and their families, and asthma care providers to work together to control asthma through school-centered health services and education. If asthma is well controlled, students will experience fewer school absences and be more productive and engaged in school.

What can school-centered programs accomplish? Several studies and systematic reviews have demonstrated that these programs improve student asthma knowledge, confidence in and actual practice of asthma management skills, regular use of preventive asthma medications, school absenteeism, school performance and urgent and emergent asthma care. However, not all studies demonstrated improvements in asthma outcomes. There are several potential reasons why benefits were not observed and possibly diluted: several interventions were provided to all students with asthma and it may be that students with more moderate to severe or poorly controlled asthma reap larger benefits than students with intermittent or

### BOX 35-1 RESOURCES FOR BUSY CLINICIANS

#### WEBSITES TO ACCESS KEY RESOURCES

- American Academy of Pediatrics
  - School Health: [www.schoolhealth.org](http://www.schoolhealth.org)
  - Schooled in Asthma: [www.aap.org/schooledinasthma](http://www.aap.org/schooledinasthma)
- American Lung Association
  - Asthma Friendly Schools Initiative Toolkit: <http://www.lung.org/lung-disease/asthma/creating-asthma-friendly-environments/asthma-in-schools/asthma-friendly-schools-initiative/>
- Centers for Disease Control
  - School and Childcare Providers: <http://www.cdc.gov/asthma/schools.html>
  - Creating an Asthma Friendly School: <http://www.cdc.gov/HealthyYouth/asthma/creatingafsf/>
  - Strategies for Addressing Asthma within a Coordinated School Health Program: <http://www.cdc.gov/healthyouth/asthma/strategies/asthmacsh.htm>
- Creating Asthma Friendly Schools (Asthma Plan of Action, Ontario Ministry of Health)
  - Creating Asthma Friendly Environments for Youth: <http://www.asthmainschools.com>
- National Association of School Nurses
  - Asthma resources and tools: <https://www.nasn.org/Tools/Resources/Asthma>
- US Environmental Protection Agency
  - Creating Healthy Indoor Environments in Schools. Tools for Schools: <http://www.epa.gov/iaq/schools/>
  - Managing Asthma in the School Environment: <http://www.epa.gov/iaq/schools/managingasthma.html>

well-controlled asthma. Although self-management behaviors improve, students have little control over environmental exposures and asthma medications prescribed for their use. Many of these studies occurred in inner cities that are known for significant trigger exposures. Research by Halterman et al<sup>25</sup> revealed that only those not living in a home with a smoker benefited from intervention. Lastly, students with asthma can only take their asthma control so far on their own as they must rely on and work with their asthma care provider. If their provider does not assess asthma control, prescribe the right medications, complete the necessary school forms and provide reinforced asthma messaging, the student loses the benefits. Many of the programs described a lack of cooperation with community asthma care providers at several levels. A review by Wheeler et al<sup>64</sup> noted that the most important lesson learned from school-centered asthma programs was the need to establish strong links to the asthma care providers of students. Collectively, research demonstrates that programs that either provide asthma care directly at school or ensure adequate links between the school and the student's asthma care provider have successfully reduced asthma morbidity.<sup>64</sup> Schools absolutely need the involvement and cooperation of asthma care providers to help students successfully manage their asthma. Efforts of asthma care providers and schools, individually and collectively, should address the medical, psychosocial and educational needs of the child/youth. The synergy created by each party playing an active role in asthma management assists students and their families to achieve asthma control and reduce associated morbidity.

Models of asthma care that place schools at the center or core of the model are applicable nationwide and may serve as a model for managing other chronic illnesses.

The complete reference list can be found on the companion Expert Consult website at <http://www.expertconsult.inkling.com>.

**TABLE 35-2** Actions for Clinicians Caring for Students with Asthma

Actions	Comments
Complete and share asthma care plans or action plans for schools	If your local school district has a standardized form, make sure this form is completed and returned to the school. As discussed above, the action plan used for home may not be suitable for the school setting. This form will allow the school health team to provide individualized care
Schedule a summer tune-up asthma visit	This visit is extremely important for having the student start school 'ready to go'. At this visit, assess asthma control, prescribe a second quick-relief inhaler for school use, and complete and review the asthma care/action plan for school use
Ensure students have a quick-relief inhaler for school use	Asthma flare-ups are often unexpected so it is key to have a quick-relief inhaler easily accessible at school. This typically involves having a second quick-relief inhaler for school use that is kept in the main office or on the student, so providing a back-up prescription is often necessary. Review the responsible use of the inhaler at school and assess and coach for accurate inhaler use
Encourage parents and students to share with the school community that the student has asthma	Schools are unable to support students to reach their full potential if they are not aware that a student has asthma. Explain to families the importance of letting the school know that the child/youth has asthma in the case of an asthma attack and the ability to use a quick relief inhaler to relieve symptoms
Request extra support for case management and care coordination for patients with poorly controlled asthma	Obtain written parental permission to send information to the school, to discuss the child's/youth's asthma condition with the school and to receive information from the school as required by FERPA (Family Educational Rights and Privacy Act). Contact the school nurse to discuss additional support that may be provided during school hours to support attainment of asthma control and to learn about and discuss previous exacerbations, use of the quick-relief inhaler, school absenteeism and participation level in school activities (gym class, recess, etc.)
Investigate what asthma resources exist at your local schools	If you have never worked directly with schools, check out valuable information at the following websites: American Academy of Pediatrics School Health ( <a href="http://www.schoolhealth.org">www.schoolhealth.org</a> ) and Schooled in Asthma ( <a href="http://www.aap.org/schooledinasthma">www.aap.org/schooledinasthma</a> )
Know your state laws and local school policies concerning asthma	At a federal level, under Individuals with Disabilities Act, Section 504 of the Rehabilitation Act of 1973 and Title II of the Americans with Disabilities Act, students with asthma are able to have access to life-saving medications and care. Several states have their own legislation regarding asthma medications and school districts may have their own specific asthma care policies, protocols and forms. At a minimum, for those without a specific asthma policy, most school districts require completion and submission of a school medication administration form to permit inhalers to be carried by the student or stored at school
Partner with a local school nurse to hold an asthma education session	Get to know your local school nurses. They welcome support in providing education to other school nurses, school personnel, students with asthma and their families
Advocate for creating supportive school environments	Offer to help develop, revise and review asthma policies and protocols in schools, such as the guidelines or protocol for how to recognize and respond to worsening asthma. Consider becoming active on a school board or the school's health and wellness committee

## KEY REFERENCES

- Basch CE. Healthier students are better learners: a missing link in school reforms to close the achievement gap. *J Schl Health* 2011;81:593–8.
- Jones SE, Wheeler L. Asthma inhalers in schools: rights of students with asthma to a free appropriate education. *Am J Public Health* 2004;94:1102–8.
- National Institutes of Health. National Heart, Lung, and Blood Institute. National Asthma Education and Prevention Program. Expert Panel Report 3: Guidelines for the Diagnosis and Management of Asthma. August 2007. NIH Publication No. 07-4051, <<http://www.nhlbi.nih.gov/guidelines/asthma/index.htm>>.
- Evans D, Clark NM, Feldman CH, Rips J, Kaplan D, Levison MJ, et al. A school health education program for children with asthma aged 8–11 years. *Health Educ Q* 1987;14:267–79.
- Coffman JM, Cabana MD, Yelin EH. Do school-based asthma education programs improve self-management and health outcomes? *Pediatrics* 2009;124:729–42.
- Al Aloola NA, Naik-Panvelkar P, Nissen L, Saini B. Asthma interventions in primary schools – a review. *J Asthma* 2014;19:1–20.
- US Environmental Protection Agency. Creating Healthy Indoor Environments in Schools. Tools for Schools, <<http://www.epa.gov/iaq/schools/>>; [Accessed on June 18, 2014].
- American Lung Association. Asthma Friendly Schools Initiative. Asthma Friendly Schools Initiative Toolkit, <<http://www.lung.org/lung-disease/asthma/creating-asthma-friendly-environments/asthma-in-schools/asthma-friendly-schools-initiative/>>; [Accessed on June 18, 2014].
- Centers for Disease Control. School and Child-care Providers, <<http://www.cdc.gov/asthma/schools.html>>; [Accessed on June 18, 2014].
- Centers for Disease Control. Initiating Change: Creating an Asthma Friendly School, <<http://www.cdc.gov/HealthyYouth/asthma/creatingaf/>>; [Accessed on June 18, 2014].
- Wheeler L, Buckley R, Gerald L, Merkle S, Morrison TA. Working with school to improve pediatric asthma management. *Pediatr Asthma Allergy Immunol* 2009;22:197–207.
- Frankowski BL. Asthma education: are pediatricians ready and willing to collaborate with schools? *Pediatrics* 2009;124:793–5.
- Cicutto L. Supporting successful asthma management in schools: the role of asthma care providers. *J Allergy Clin Immunol* 2009;124:390–3.

## REFERENCES

- Asthma and Allergy Foundation of America. Asthma Facts and Figures, <<http://www.aafa.org/display.cfm?id=9&sub=42>>; [Accessed on June 1, 2014].
- Akinbami LJ, LaFleur BJ, Schoendorf KC. Racial and income disparities in childhood asthma in the United States. *Ambul Pediatr* 2002;2:382–7.
- Meng MY, Babey SH, Wolstein J. Asthma-related school absenteeism and school concentration of low-income students in California. *Prev Chronic Dis* 2012;9:E98.
- Liberty KA, Pattermore P, Reid J, Tarren-Sweeney M. Beginning school with asthma independently predicts low achievement in a prospective cohort of children. *Chest* 2010;138:1349–55.
- Fowler MG, Davenport MG, Garg R. School functioning of US children with asthma. *Pediatrics* 1992;90:939–44.
- Basch CE. Healthier students are better learners: a missing link in school reforms to close the achievement gap. *J Schl Health* 2011;81:593–8.
- Kann L, Brener ND, Wechsler H. Overview and summary: School Health Policies and Programs Study 2006. *J Schl Health* 2007;77:385–97.
- Jonsson M, Egmar AC, Hallner E, Kull I. Experiences of living with asthma- a focus group study with adolescents and parents of children living with asthma. *J Asthma* 2014;51:185–92.
- Liberatos P, Leone J, Craig AM, Frei EM, Fuentes N, Harris IM. Challenges of asthma management for school districts with high asthma hospitalization rates. *J Sch Health* 2013;83:867–75.
- Egginton JS, Textor L, Knoebel E, McWilliams D, Aleman M, Yawn B. Enhancing school asthma action plans: qualitative results from southeast Minnesota Beacon stakeholder groups. *J Sch Health* 2013;83:885–95.
- Cicutto L, Conti E, Evans H, Lewis R, Murphy S, Rautiainen KC, et al. Creating asthma-friendly schools: a public health approach. *J Sch Health* 2006;76:255–8.
- Gerald JK, Stroupe N, McClure LA, Wheeler L, Gerald LB. Availability of asthma quick relief medication in five Alabama School Systems. *Pediatr Allergy Immunol Pulmonol* 2012;25:11–16.
- Taras H, Wright S, Brennan J, Campana J, Lofgren R. Impact of school nurse case management on students with asthma. *J Sch Health* 2004;74:213–19.
- Jones SE, Wheeler L. Asthma inhalers in schools: rights of students with asthma to a free appropriate education. *Am J Public Health* 2004;94:1102–8.
- Hanson TK, Aleman M, Hart L, Yawn B. Increasing availability to and ascertaining value of asthma action plans in schools through use of technology and community collaboration. *J Sch Health* 2013;83:915–20.
- Walker TJ, Reznik M. In-school asthma management and physical activity: children's perspectives. *J Asthma* 2014;51:808–13.
- Richmond CM, Sterling D, Huang X, Wilson K, Pike E. Asthma 411- addition of a consulting physician to enhance school health. *J Sch Health* 2006;76:328.
- Wilson KD, Moonie S, Sterling DA, Gillespie KN, Kurz RS. Examining the consulting physician model to enhance school nurse role for children with asthma. *J Sch Health* 2009;79:1–7.
- Rodriguez E, Rivera DA, Perloth D, Becker E, Wang NE, Landau M. School nurses' role in asthma management, school absenteeism, and cost savings: a demonstration project. *J Sch Health* 2013;83:842–50.
- Guu JJ, Jang R, Keller KN, McCracken AL, Pan W, Cluxton RJ. Impact of school-based health centers in children with asthma. *J Adolesc Health* 2005;37:266–74.
- Webber MP, Carpinello KE, Oruwareye T, Lo Y, Burton WB, Appel DK. Burden of asthma in inner-city elementary schoolchildren: do school-based health centers make a difference. *Arch Pediatr Adolesc Med* 2003;157:125–9.
- Patel B, Sheridan P, Detjen P, Donnersberger D, Gluck E, Malamut K, et al. Success of a comprehensive school-based asthma intervention on clinical markers and resource utilization for inner-city children with asthma in Chicago: the mobile C.A.R.E. Foundation's asthma management program. *J Asthma* 2007;44:113–18.
- Liao O, Morphey T, Amaro S, Galant SP. The Breathmobile: a novel comprehensive school-based mobile asthma care clinic for urban underprivileged children. *J Sch Health* 2006;76:313–19.
- Jones CA, Clement LT, Hanley-Lopez J, Morphey T, Kwong KY, Lifson F, et al. The Breathmobile Program: structure, implementation, and evolution of a large-scale, urban, pediatric asthma disease management program. *Dis Manag* 2005;8:205–22.
- Halterman JS, Szilagyi PG, Yoos HL, Conn KM, Kaczorowski JM, Holzhauser RJ, et al. Benefits of a school-based asthma treatment program in the absence of secondhand smoke exposure: results of a randomized clinical trial. *Arch Pediatr Adolesc Med* 2004;158:460–7.
- Halterman JS, Szilagyi PG, Fisher SG, Fagnano M, Tremblay P, Conn KM, et al. Randomized controlled trial to improve care for urban children with asthma: results of a school-based asthma therapy trial. *Arch Pediatr Adolesc Med* 2011;165:262–8.
- Gerald LB, McClure LA, Mangan JM, Harrington KF, Gibson L, Erwin S, et al. Increasing adherence to inhaled steroid therapy among schoolchildren: randomized, controlled trial of school-based supervised asthma therapy. *Pediatrics* 2009;123:466–74.
- Splett P, Erickson C, Belseth S, Jensen C. Evaluation and sustainability of the Healthy Learners Asthma Initiative. *J Schl Health* 2006;76:276–82.
- Joseph CL, Ownby DR, Havstad SL, Saltzgaber J, Considine S, Johnson D, et al. Evaluation of a web-based asthma management intervention program for urban teenagers: reaching the hard to reach. *J Adolesc Health* 2013;52:419–26.
- Cicutto L, Gleason M, White M, Haas-Howard C, Shocks D, Szeffler SJ. Building Bridges for Better Asthma Care: a program connecting schools, students with asthma and their health care providers for optimizing outcomes. *Am J Respir Crit Care Med* 2014;189:A2453.
- Levy M, Heffner B, Stewart T, Beeman G. The efficacy of asthma case management in an urban school district in reducing school absences and hospitalizations for asthma. *J Sch Health* 2006;76:320–4.
- Portwood SG, Nelson EB. Data sharing to inform school-based asthma services. *J Sch Health* 2013;83:851–8.
- Szeffler SJ. Managing asthma and allergies in schools. An opportunity to coordinate health care. *J Allergy Clin Immunol* 2009;124:201–4.
- National Institutes of Health. National Heart, Lung, and Blood Institute. National Asthma Education and Prevention Program. Expert Panel Report 3: Guidelines for the Diagnosis and Management of Asthma. August 2007. NIH Publication No. 07-4051, <<http://www.nhlbi.nih.gov/guidelines/asthma/index.htm>>.
- Cicutto L, Murphy S, Coutts D, O'Rourke J, Lang G, Chapman C, et al. Breaking the access barrier: evaluating an asthma center's efforts to provide education to children with asthma in schools. *Chest* 2005;128:1928–35.
- Cicutto L, To T, Murphy S. A randomized controlled trial of a public health nurse delivered asthma program to elementary schools. *J Sch Health* 2013;83:876–84.
- Butz A, Pham L, Lewis L, Lewis C, Hill K, Walker J, et al. Rural children with asthma: impact of a parent and child asthma education program. *J Asthma* 2005;42:813–21.
- Evans D, Clark NM, Feldman CH, Rips J, Kaplan D, Levison MJ, et al. A school health education program for children with asthma aged 8–11 years. *Health Educ Q* 1987;14:267–79.
- Christiansen SC, Martin SB, Schleicher NC, Koziol JA, Mathews KP, Zuraw BL. Evaluation of a school-based asthma education program for inner-city children. *J Allergy Clin Immunol* 1997;100:613–17.
- McGhan SL, Wong E, Jhangri GS, Wells HM, Michaelchuk DR, Boechler VL, et al. Evaluation of an education program for elementary school children with asthma. *J Asthma* 2003;40:523–33.
- McGhan SL, Wong E, Sharpe HM, Hessel PA, Mandhane P, Boechler VL, et al. A children's asthma education program: Roaring Adventures of Puff (RAP) improves quality of life. *Can Respir J* 2010;17:67–73.
- Clark NM, Brown R, Joseph CL, Anderson EW, Liu M, Valerio MA. Effects of a comprehensive school-based asthma program on symptoms, parent management, grades and absenteeism. *Chest* 2004;125:1674–9.
- Bruzzese JM, Markman LB, Appel D, Webber M. An evaluation of Open Airways for Schools: using college students as instructors. *J Asthma* 2001;38:337–42.
- Coffman JM, Cabana MD, Yelin EH. Do school-based asthma education programs improve self-management and health outcomes? *Pediatrics* 2009;124:729–42.
- Al Aolola NA, Naik-Panvelkar P, Nissen L, Saini B. Asthma interventions in primary schools – a review. *J Asthma* 2014;19:1–20.
- Magzamen S, Patel B, Davis A, Edelstein J, Tager IB. *Kickin' Asthma*: a school based asthma education program in an urban community. *J Schl Health* 2008;78:655–65.
- Davis A, Brown AS, Edelstein J, Tager IB. Identification and education of adolescents with asthma in an urban school district: results form a large-scale asthma intervention. *J Urban Health* 2008;85:361–74.
- Bruzzese JM, Sheares BJ, Vincent EJ, Du Y, Sadeghi H, Levison MJ, et al. Effects of a school-based intervention for urban adolescents with asthma. A controlled trial. *Am J Respir Crit Care Med* 2011;183:998–1006.
- Shah S, Peat JK, Mazurski EJ, Wang H, Sindhusake D, Bruce C, et al. Effect of peer led programme for asthma education in adolescents: cluster randomised controlled trial. *BMJ* 2001;322:583–5.

50. Kouba J, Velsor-Friedrich B, Militello J, Harrison PR, Becklenberg A, White B, et al. Efficacy of the I Can Control Asthma and Nutrition Now (ICAN). *J Sch Nurs* 2012;3:235–47.
51. Center for Disease Control. Healthy Youth. Strategies for Addressing Asthma within a Coordinated School Health Program. Revised Fall 2006. Atlanta, GA.: Centers for Disease Control and Prevention, National Center for Chronic Disease Prevention and Health Promotion. Available at: <<http://www.cdc.gov/healthyyouth/asthma/strategies/asthmacsh.htm>>; [Accessed on June 17, 2014].
52. Asthma Plan of Action. Creating asthma friendly environments for youth, <<http://www.asthmainschools.com>>.
53. US Environmental Protection Agency. Creating Healthy Indoor Environments in Schools. Tools for Schools, <<http://www.epa.gov/iaq/schools/>>; [Accessed on June 18, 2014].
54. American Lung Association. Asthma Friendly Schools Initiative. Asthma Friendly Schools Initiative Toolkit, <<http://www.lung.org/lung-disease/asthma/creating-asthma-friendly-environments/asthma-in-schools/asthma-friendly-schools-initiative/>>; [Accessed on June 18, 2014].
55. Centers for Disease Control. School and Child-care Providers, <<http://www.cdc.gov/asthma/schools.html>>; [Accessed on June 18, 2014].
56. Centers for Disease Control. Initiating Change: Creating an Asthma Friendly School, <<http://www.cdc.gov/HealthyYouth/asthma/creatingafgs/>>; [Accessed on June 18, 2014].
57. Greiling AK, Boss LP, Wheeler LS. A preliminary investigation of asthma mortality in schools. *J Sch Health* 2005;75:286–90.
58. Eisenberg JD, Moe EL, Stillger CF. Educating school personnel about asthma. *J Asthma* 1993; 30:351–8.
59. Neuharth-Pritchett S, Getch YQ. Asthma and the school teacher: the status of teacher preparedness and training. *J Sch Nurse* 2001;17: 323–8.
60. Goei R, Boyson AR, Lyon-Callo SK, Schott C, Wasilevich E, Cannarile S. Developing an asthma tool for schools: the formative evaluation of Michigan's asthma school packet. *J Sch Health* 2006;76:259–63.
61. Keysser J, Splett PL, Ross S, Fishman E. State-wide asthma training for Minnesota school personnel. *J Sch Health* 2006;76:264–8.
62. Noyes K, Bajorska A, Fisher S, Sauer J, Fagnano M, Halterman JS. Cost-effectiveness of the School-Based Asthma Therapy (SBAT) program. *Pediatrics* 2013;131:e709–17.
63. Tai T, Baime SI. Cost-benefit analysis of childhood asthma management through school-based clinic programs. *J Community Health* 2011;36:253–60.
64. Wheeler LS, Merkle SL, Gerald LB, Taggart VS. Managing asthma in schools: lessons learned and recommendations. *J Sch Health* 2006;76: 340–4.
65. Wheeler L, Buckley R, Gerald L, Merkle S, Morrison TA. Working with school to improve pediatric asthma management. *Pediatr Asthma Allergy Immunol* 2009;22:197–207.
66. Frankowski BL. Asthma education: are pediatricians ready and willing to collaborate with schools? *Pediatrics* 2009;124:793–5.
67. Cicutto L. Supporting successful asthma management in schools: the role of asthma care providers. *J Allergy Clin Immunol* 2009;124: 390–3.



# Exercise-Induced Asthma: Strategies to Improve Performance

J. TOD OLIN

## KEY POINTS

- Prevalence of exercise-induced bronchoconstriction (with or without baseline asthma) may be as high as 20% of the population of casual exercisers, and much higher in specific risk groups.
- Initiating events in exercise-induced asthma include an osmotic insult to airway epithelial cells.
- Multiple indirect challenge tests are becoming available as surrogates for clinic-based exercise challenges.
- While novel therapeutics have not been developed for exercise-induced asthma, there is emerging data that dietary changes may offer therapeutic benefit.
- In patients requiring several medications for exercise-induced asthma, practitioners should consider alternative diagnoses including upper airway obstruction.

## Introduction

The ability to exercise comfortably is of central importance in the lives of patients of all ages. Exercise-induced bronchoconstriction (EIB) and exercise-induced asthma (EIA) are two similar conditions which can significantly impair this ability. EIB is defined as transient airflow obstruction in response to an exercise stimulus. In patients with previously diagnosed asthma, the term EIA describes the same phenomenon.

These conditions are important for several reasons. From a public health standpoint, in an age when guidelines from several health oversight committees strongly advocate frequent and vigorous exercise, the most important impact of bronchospasm is its tendency to make exercise uncomfortable, decreasing the frequency, intensity and duration of exercise bouts in children and adults. Additionally, from a performance standpoint, bronchospasm may impair performance through either ventilatory limitation or dyspnea.

Our understanding of the pathophysiology of bronchospasm is evolving in an age of improved biometric analyses. This insight has led to improved diagnostic strategies and may continue to do so among different groups of patients across different ages and performance requirements. It may also lead to therapeutic advances and more personalized strategies.

This chapter focuses mainly on the clinical features, pathophysiology, diagnostic strategies and treatments for EIA. When appropriate, the chapter makes specific reference to data applicable to isolated EIB. A section is devoted to specific groups of patients and athletes that require more individualized

considerations. For completeness, it briefly reviews the epidemiology and impact of EIA as well as the differential diagnosis of exertional dyspnea.

## Epidemiology

The number of people that suffer from EIA is staggering. In 2010, in the USA alone, over 25 million people were estimated to have asthma.<sup>1</sup> Worldwide, an estimated 300 million people are affected.<sup>2</sup> Specific high-risk groups include people of Puerto Rican, African American, and multiple race heritage as well as those living in urban areas or born to low-income parents.<sup>1,3,4</sup> The majority of these patients with baseline asthma describe characteristic symptoms associated with EIA.<sup>5</sup>

In addition to isolated asthma patients, the preterm birthrate is nearly 12% in the USA and the rate of associated chronic lung disease varies inversely with gestational age.<sup>6</sup> Patients with chronic lung disease of prematurity are much more likely than controls to experience EIA.<sup>7</sup>

Prevalence estimates for isolated EIB vary, but may be as high as 20% of casual adult exercisers.<sup>8</sup> Among athletes, this number can be much higher, depending on the specific sport studied and testing methodology employed.<sup>9,10</sup> Excellent summaries of EIB prevalence studies among athletes have been published.<sup>11</sup>

Children are also affected by EIA, and prevalence varies by location and methodology from 4% to 20% in different studies.<sup>12,13</sup> There is debate as to the existence of isolated EIB in young children because airway hyperreactivity is such a strong predictor of asthma onset at a future date, although many children diagnosed with EIA do not show signs of respiratory disease outside of exercise.<sup>14</sup>

## Impact

The burden of EIA takes many forms, including mortality and quantified morbidity. Death due to EIA is exceedingly rare, but has been reported.<sup>15</sup> From the public health perspective, exercise avoidance due to EIA may be the most important burden on health. Children with untreated asthma have been shown to be less fit than age-matched controls.<sup>16</sup> Moreover, asthma has been identified as a barrier to activity in children with measured inactivity, although this finding has not been replicated in all populations.<sup>17-19</sup> The causal relationships between asthma and obesity are not fully understood, although both appear to affect each other. Moreover, there is reasonable fear that increased sedentary time in response to an asthma diagnosis or symptoms could lead to future increases in obesity, cardiovascular disease and death.<sup>20</sup> From a cognitive perspective, in addition to asthma being a barrier to activity, EIA is associated with a decreased health-related quality of life.<sup>21</sup>

The effect of untreated or undertreated EIA on performance is somewhat more difficult to quantify for ethical reasons. It is common for patients to complain of symptoms related to exercise and performance, but the effect of the bronchoconstriction that causes symptoms likely has variable effects on specific task performance. Possible causes of decreased performance related to bronchoconstriction include ventilatory limitation, increased work of breathing leading to decreased substrate delivery to performance muscles (without observed ventilatory limitation), and performance limitation due to dyspnea.

Treated EIB seems to have minimal impact on performance. In Olympic competition, using medals as the outcome of performance, there are no important differences between patients that carry a diagnosis of active asthma and nonasthmatic athletes.<sup>22</sup>

## Pathophysiology

There has been considerable debate regarding the mechanisms leading to EIA in the last four decades. It is possible that there is no unifying theory explaining all laboratory and clinical observations in EIA, but rather multiple phenotypes of disease which may vary across ages, exposures and characteristics of the underlying asthma. It is recognized that the central event in EIB is rapid airway epithelial water loss extending to smaller generations of airways due to an inability of the upper airway to adequately condition inspired air. EIB can be largely blunted simply by inspiring warm humid air. Two competing, but not mutually exclusive, hypotheses explain many of the downstream clinical phenomena observed in EIB: the osmotic hypothesis and the thermal hypothesis.

According to the osmotic hypothesis, the airway epithelial water loss leads to an increased osmolarity of the airway surface lining fluid. In response to this change, water then flows from epithelial and subepithelial cells in order to maintain equilibrium. This secondary flow of water causes intracellular changes and leads to the release of mediators which ultimately lead to bronchoconstriction. In 2014, it appears that experimental evidence favors this osmotic hypothesis over the thermal hypothesis.

According to the thermal hypothesis, airway cooling and subsequent bronchial vasoconstriction are followed by a reactive hyperemia. This vascular engorgement is considered to cause airway narrowing. Among other evidence consistent with this hypothesis are the interesting findings that inhalation of cold dry air or norepinephrine after exercise can attenuate EIB.<sup>23</sup> It is important to note that airway warming and cooling are not required to trigger bronchospasm, an observation which has called into question the role of thermal change in EIA.

In addition to osmotic and thermal changes, the hyperpnea associated with exercise exposes the epithelium to increased mechanical stress as well as increased exposure to noxious agents. Airway desquamation is known to occur in response to exercise challenge in patients with EIA, although controls may also exhibit this phenomenon.<sup>24,25</sup> There is evidence the oxidative stress at an epithelial level may be somewhat higher in patients that suffer from EIA.<sup>26</sup> Through mechanisms that are not entirely elucidated, it is felt that dysfunctional injury repair mechanisms may predispose patients to both the acute and chronic changes seen in EIA. This is, in part, supported by observations that exercise challenges in patients with EIA, compared to controls, increase epithelial-

derived 15S-hydroxyicosatetraenoic acid (proinflammatory) and decrease epithelial-derived prostaglandin E<sub>2</sub> (PGE<sub>2</sub>) (anti-inflammatory).<sup>24,27</sup>

The osmotic, thermal, and mechanical stresses that occur during exercise indirectly cause bronchospasm via a complex and incompletely understood cascade involving multiple effector cells and mediators (Figure 36-1). In addition to epithelial sources, key mediators of bronchospasm have been linked to increased numbers of mast cells and eosinophils.<sup>24,28</sup> A possible link between epithelial stress and effector cells is a combination of interleukin 33 (IL-33) and thymic stromal lymphopoietin, epithelial-derived mediators which affect mast cell differentiation and release of cysteinyl leukotrienes (cysLTs) and PGD<sub>2</sub>.<sup>29</sup>

cysLTs, derived from mast cells and eosinophils, have been strongly implicated in the pathogenesis of EIB, although their actions do not explain all observed bronchospasm. They have been detected in increased amounts in both exhaled breath condensate and sputum of patients with EIA.<sup>30,31</sup> Clinical trials using leukotriene receptor antagonists (LTRAs) and leukotriene synthesis inhibitors for prevention of bronchoconstriction consistently demonstrate incomplete inhibition of bronchospasm.<sup>32,33</sup>

Histamine is also implicated in EIA. Released primarily from mast cells in response to an exercise stimulus, it is thought to mediate the initial events in EIA.<sup>34</sup> Antagonism seems to prevent bronchospasm in response to surrogate challenge, but has not consistently shown clinical benefit in exercise challenges.<sup>35</sup>

There are mediators which may play protective roles in EIA, although much remains to be studied in this area. Lipoxin A4 levels appear to decrease in patients with notable EIA compared to controls.<sup>36</sup> Prostaglandins may play a role in EIA, as suggested by antagonism studies using cyclooxygenase inhibitors as well as in primary studies of the airway in EIA, but mechanisms are poorly understood.<sup>24,37</sup> Prostaglandins have been most convincingly implicated by their role in modulating refractoriness to repeated exercise challenges (a phenomenon which will be described later), although the precise mechanisms are far from clear.<sup>37</sup>

Our understanding of the roles of sensory nerves and parasympathetic efferents is evolving. Neurokinins are released from sensory nerve fibers in response to a variety of stimuli, including hyperosmolar stimuli. Among other functions, neurokinins can stimulate secretion of mucin 5AC.<sup>38</sup> Parasympathetic innervation, known to be involved in asthmatic responses due to the tendency for patients with asthma to demonstrate bronchoconstriction in response to methacholine, likely plays a more variable role in EIA across patients (as has been shown for decades).<sup>39</sup> Some of the variability may be a result of differences in baseline vagal tone across subjects.<sup>40,41</sup>

It is plausible to consider potential constitutive or induced differences in airway smooth muscle as predisposing factors to developing EIA for a variety of reasons, but there is a paucity of data regarding causal links in the area (especially in pure EIB).<sup>42</sup> In addition to presumed mass-bronchoconstriction force mechanisms, the muscle itself may act to secrete mediators perpetuating inflammatory responses. Future research is needed in this area to clarify these possibilities as well as their relative importance to the overall clinical phenotype of EIA.

Refractoriness to EIA, the phenomenon in which repeated exercise challenge elicit a decremental bronchospastic response over a period of hours, may involve mediators other than those described above (although a precise mechanism is unknown).

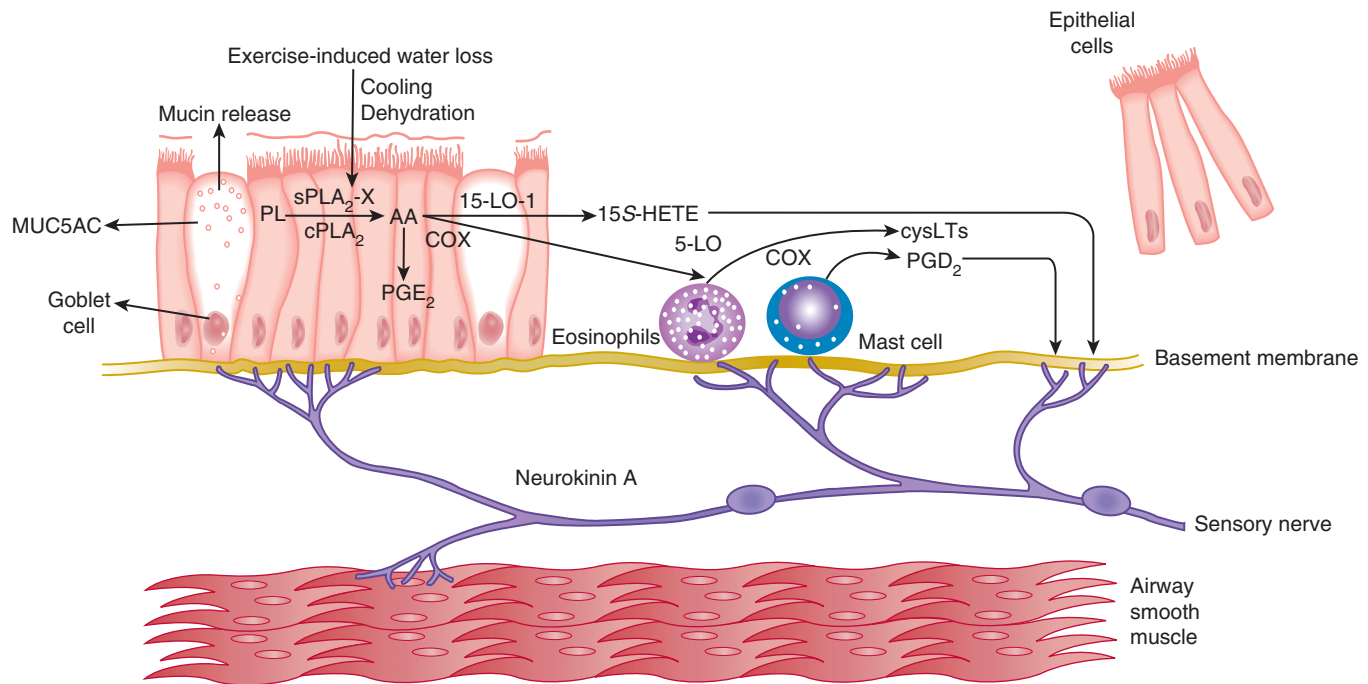

**Figure 36-1** Disease model of exercise-induced bronchoconstriction (EIB) pathogenesis. Asthmatics with EIB have increased concentrations of shed epithelial cells, cysteinyl leukotrienes (cysLTs) and cysLT-to-prostaglandin  $E_2$  ( $PGE_2$ ) ratio in induced sputum. Exercise challenge initiates the production of cysLTs,  $PGD_2$ , and 15S-hydroxyeicosatetraenoic acid (15S-HETE), and a reduction in  $PGE_2$ . An increase in secreted phospholipase  $A_2$  group X (sPLA $_2$ -X) may increase the release of arachidonic acid (AA) by the epithelium or by adjacent inflammatory cells. Contraction of the airway smooth muscle and mucin release occurs in part through retrograde axonal transmission in sensory nerves that release neurokinin A. 15-LO-1 – 15-lipoxygenase-1; 5-LO – 5-lipoxygenase; COX – cyclooxygenase; cPLA $_2$  – cytosolic phospholipase  $A_2$ ; MUC5AC – mucin 5AC; PL – phospholipids. (From Hallstrand TS, Henderson WR. Role of leukotrienes in exercise-induced bronchoconstriction. *Curr Allergy Asthma Rep* 2009;9:18–25. Copyright © 2009 by Current Medicine Group LLC, reproduced with permission.)

The mediators are likely similar to those induced by other indirect airway challenges as cross-refractoriness is known to occur between hyperventilation and exercise as well as mannitol and exercise. However, refractoriness does not necessarily exist between indirect and direct challenges. Catecholamine release, while initially suspected, is not thought to play an important role.<sup>43</sup> Prostaglandin release in response to indirect stimuli (implicated due to the ability of indomethacin to eliminate refractoriness) and tachyphylaxis of cysLT receptors are the most widely accepted mechanisms of refractoriness at this time.<sup>37,44</sup>

## Characteristic Clinical Features

Patients describe EIA in terms of a variety of symptoms. Cough is generally the most common in study settings. Wheeze, chest tightness, disproportionate dyspnea for a given task and increased mucus production are also common symptoms.<sup>45</sup> Symptoms generally occur after at least 8 to 10 minutes of exercise and persist for 30 to 45 minutes. At times, patients describe a phenomenon in which symptoms improve after continued exercise (the spirometric physiology of which is detailed below). Symptoms may vary in terms of frequency and severity with multiple environmental and exercise-associated factors, specifically worsening in cold, dry environments with high allergen or pollutant content. Activities with high ventilatory requirements (e.g. cross country skiing) are more likely to trigger symptoms than activities with low ventilatory requirements (e.g. golf). Generally, patients do not describe loud, audible breathing, severe distress or cyanosis (although fatal

events are rarely documented in the literature). Generally, chest pain, pallor and syncope are not features of the disease.

On physical examination, patients generally appear normal in a clinic setting. Given the high proportion of patients that suffer from baseline asthma and atopy, stigmata of asthma and atopic disease may be present. Cyanosis, an extreme barrel chest, auscultated crackles and clubbing are not features of EIA and suggest alternative diagnoses.

In terms of diagnostic testing commonly available in the clinic setting, findings are often completely normal, but like the physical exam, may suggest baseline asthma and atopy. Resting spirometry may be normal or suggest obstruction. Bronchodilator response above resting spirometry may be present as well. Skin testing and exhaled nitric oxide testing are often positive. Chest radiography is generally normal, but may demonstrate hyperinflation. Definitive provocative testing is described in a later section.

The classic spirometric pattern demonstrated with bouts of exercise is one in which airflow may increase slightly during and immediately after exercise, decline to nadir values roughly 10–15 minutes after exercise and spontaneously resolve to near-baseline levels within 60 minutes. For unclear reasons, young children may demonstrate a slightly different pattern, with an earlier onset of measurable bronchoconstriction associated with a more depressed nadir.<sup>46</sup>

One feature of EIA that is distinct from most other causes of dyspnea is refractoriness. Patients often describe this as the ability to ‘run through asthma’. Many patients with EIA, following an initial airway stress (which may or may not cause measured airway obstruction), can exercise without the degree of

bronchoconstriction typically experienced for a given task.<sup>47</sup> As noted above, the mechanisms behind this phenomenon are unclear and are likely similar across multiple indirect airway challenges.

The existence of a second phase in EIA is controversial and will not be reviewed in this chapter.

## Groups Requiring Special Consideration

Several individual groups of patients with EIA require special consideration due to the frequency and severity of symptoms. Winter sport athletes who participate in activities requiring high ventilation are particularly susceptible to EIA and isolated EIB.<sup>10</sup> Warm weather endurance athletes suffer EIA and EIB at a somewhat lower rate.<sup>48</sup> The reasons for this are likely related to the magnitude of osmotic stress induced by the activities involved.

In addition to endurance exercise and cold weather exercise, exercise in environments with a high degree of particulate pollution is associated with high rates of EIA.<sup>49</sup> This may particularly affect those who exercise in an urban area and those who exercise at indoor facilities cleaned or serviced by machines that emit particulate matter, including ice polishers.

Swimmers, while experiencing warm humid air while exercising, are exposed to high levels of a variety of compounds formed by the interaction of nitrogen-containing compounds and chlorine. In terms of acute bronchospasm, a high proportion of competitive swimmers suffer from symptoms.<sup>9</sup> Chronic effects are less clear, with some authors suggesting a role for chlorine as a causative agent for asthmatic phenotypes later in life.<sup>50</sup>

There are some young children who demonstrate severe EIA once old enough to perform spirometry. This seems to be associated or predicted by airflow limitation detected during (rather than after) exercise bouts, a phenomenon described as 'break-through EIB.' The mechanisms behind this severe decline are unclear. It is possible that the small airway caliber of children is to blame. It is also possible that large airway dysfunction plays a more important role than in older populations.<sup>51</sup>

## Differential Diagnosis

The differential diagnosis of EIA is quite broad, although several competing causes of exertional dyspnea are quite rare, especially in younger populations.

It cannot be overstated that the most important diagnosis to consider in a patient with known or suspected EIA or EIB is poorly-treated baseline asthma, especially in younger populations. Bronchial hyperresponsiveness is strongly suggestive of asthma and predictive of the development of asthma.<sup>52</sup>

Inducible laryngeal obstruction at the glottic and supraglottic level should be strongly considered in patients that do not respond to inhaled bronchodilators. This is an umbrella term that includes paradoxical vocal fold motion as well as prolapse of the arytenoid cartilages. Clinically, patients with these conditions often describe rapid onset and resolution of symptoms when compared to typical cases of EIA. Rather than describe a typical refractory period, patients often describe worsening dyspnea with repetitive exercise. Symptoms often are associated with a high degree of distress as opposed to the mild discomfort

typically associated with EIA. Inspiratory stridor can be present, but is not seen in all cases as it is likely a function of both the degree of obstruction and the instantaneous air flow rate. Regardless of stridor, hypoxemia is rare. The gold standard for diagnosis of these conditions is direct laryngoscopic visualization, but the intermittent nature of the condition can present challenges. Some highly-specialized centers advocate the use of continuous laryngoscopy during exercise.<sup>53</sup>

Hypoxemia can be the cause of exertional dyspnea and performance limitation in the absence of overt distress. It can be normal for well-trained athletes to achieve mild hypoxemia (from the high 80s to low 90s) even at sea level.<sup>54</sup> Generally, more important hypoxemia is associated with a degree of cyanosis. Intrapulmonary shunts have been described as a potential cause of hypoxemia. In younger populations, undiagnosed conditions leading to this degree of hypoxemia are rare (largely because cyanotic heart disease is detected at earlier ages).

Dysrhythmias have been described as a cause of exertional dyspnea. Generally, they should not be associated with cyanosis or hypoxemia. Rarely, muscle disease can manifest as dyspnea out of proportion to work rate.

The deconditioned patient presents challenges from a diagnostic perspective. There are no widely accepted criteria to quantitatively diagnose deconditioning. Moreover, a diagnosis of deconditioning does not exclude other causes of dyspnea.

## Diagnostics

There are several diagnostic strategies used to confirm a diagnosis of EIA. Each has benefits and drawbacks when considering sensitivity, specificity, feasibility and cost.

In select cases, clinical history alone may be an option. It is clear that this is not an ideal option in patients capable of performing more specific testing because history alone is associated with both over- and under-diagnosis of EIB.<sup>45</sup> However, for young patients with developmental or musculoskeletal conditions that prevent exercise testing or centers without the infrastructure for specialized testing, this must be considered. In this context, empirical trials of bronchodilators before exercise aid in the diagnosis.

Exercise challenges are another option that should be considered in patients complaining of exertional dyspnea. In order to confirm a diagnosis, clinicians should observe a decline in the forced expiratory volume in one second (FEV<sub>1</sub>) of 10% to 15% after exercise. Receiver-operator curves have demonstrated optimal threshold values for positive and negative test interpretation, although individual considerations and testing conditions must enter the diagnostic equation.<sup>55</sup> Recent consensus guidelines recommend the use of a 10% decline in adults and a 12% decline in children as threshold values.<sup>56</sup>

There are several benefits to formal exercise testing. Exercise intensity, a variable which has been clearly demonstrated to affect the likelihood of triggering EIA, can be closely monitored in a laboratory setting. The availability of measurement equipment is also an advantage. Additionally, patients can conceptualize the challenge and accept the results as the challenge is more conceptually familiar than the other indirect airway challenges mentioned below.

The drawbacks of exercise challenges include the fact that ambient conditions are often not conducive to triggering bronchospasm because laboratories offer warm and relatively humid environments. Additionally, standard exercise protocols may



not be sufficient to trigger bronchospasm in all patients. The time course of achieving higher work rates and thus high ventilatory rates as well as the duration of exercise challenge can both affect the sensitivity of the test. Challenges which are either too short or too long in duration may not result in a positive test. The mode of exercise also affects the sensitivity of the test in patients that have different ventilatory rates across different modes of exercise at the highest sustainable work rate.

As an alternative to laboratory testing, field testing has been advocated by several authors.<sup>57</sup> When compared with laboratory-based testing, field testing offers the advantages of cold, dry environments and exercise scenarios that are comparable to everyday activities. Drawbacks include the inability of the tester to closely monitor exercise intensity as well as of performing the challenge tests in close proximity to measurement equipment.

Outside of exercise, there are multiple inhaled challenges that can confirm a diagnosis of EIA. Methacholine challenge is a direct airway challenge, which can quantify the degree of airway hyperresponsiveness. Its benefits include broad availability as well as decades of use in hospital settings. However, methacholine causes bronchoconstriction through mechanisms not necessarily present in EIA. For this reason, overlap between patients with methacholine-induced airways hyperresponsiveness and pure EIB is not perfect.<sup>58</sup>

Eucapnic voluntary hyperventilation is a challenge that mimics the high ventilatory rates associated with exercise.<sup>59</sup> In this challenge, the patient attempts to maintain maximum voluntary ventilation while breathing from a circuit which offers 5% carbon dioxide. Its benefits include its lack of dependence on environmental conditions because the breathing circuit is isolated from the laboratory environment. Additionally, it bypasses the need for exercise equipment in the laboratory. Its drawbacks include its somewhat limited availability.

Hyperosmolar challenge with inhaled mannitol offers another means of assessing airways hyperresponsiveness.<sup>60</sup> Mannitol offers an indirect challenge and is thought to cause the same fluid shifts from the submucosal tissue to the airways surface lining fluid. Its benefits include its relatively high concordance with properly-conducted exercise challenge and drawbacks include its somewhat limited availability.

## Therapeutics

There are several available therapeutic agents for EIA, which target a number of mediators and effector cells. Of interest, there is no single therapy that has been universally successful. The differences between patients with regard to treatment response may suggest that multiple physiological phenotypes of EIB exist, each with an ideal individualized therapy. There are multiple published guidelines to assist practitioners with decision-making regarding medications.<sup>56,61</sup> The guidelines for EIA treatment are generally compatible with treatment of underlying asthma, although there are some notable areas of conflict which the practitioner should be aware of.

The title of this chapter implies that these therapies can improve performance. While this is presumably true in concept, the vast majority of clinical trials in the area of EIB do not assess performance directly. Moreover performance as an outcome will presumably vary in terms of assessment from sport to sport. For the purposes of this section, the reader can assume that medication efficacy is defined by its ability to preserve lung

function measured as a post-exercise or post-surrogate challenge FEV<sub>1</sub>.

Since the last edition of this text, most progress with regards to asthma therapies has been with biological agents. These agents are not currently being studied for their effects on prevention of EIB, mainly due to their cost as well as the cost and feasibility of the challenges associated with using exercise testing as a clinical trials outcome measure. While there have been rare case reports of successful therapy of exercise-induced anaphylaxis with omalizumab, it will likely be several years before we understand the full effect of biologicals on EIA.<sup>62</sup> One can hope that, through improving underlying inflammation in patients with baseline asthma, the impact of EIA will be lessened through novel asthma therapies.

Most new therapeutic insights in EIA and EIB have been made in the area of adjunctive therapies, including dietary modifications (e.g. omega-3 fatty acids and low salt diets). A review of the available medications will precede discussion of behavioral strategies (Table 36-1).

Short-acting  $\beta$ -agonists (SABAs) have long been the mainstay of prevention and treatment of EIA. Target receptors for these medications are present on mast cells and airway smooth muscle. In patients with recurrent symptoms, their use is recommended 15 minutes before activity and their effects persist for about 3 hours.<sup>63</sup> They are effective in the majority of patients, but do not provide complete protection in roughly 20% of patients. Despite their efficacy, a consideration with these medications is the development of physiological tolerance to the medications.<sup>64</sup> With this phenomenon in mind, it is recommended that patients with frequent need for SABAs also use controller agents.

Inhaled steroids provide a small degree of acute protection against EIB, but are utilized mainly as a daily controller in baseline asthma.

LTRAs are known to decrease EIB when compared with placebo, increasing the nadir lung function after exercise challenge by as much as 8% to 10%. They have been strongly recommended for patients incompletely controlled on SABAs alone or for those who use daily SABAs.<sup>56</sup> While clearly not as effective as SABAs, LTRAs remain equally effective after 1 month of therapy, avoiding problems of medication tolerance.

Long-acting  $\beta$ -agonists (LABAs) provide protection against EIB that lasts for several hours. Similar to their short-acting analogs however, they induce tachyphylaxis.<sup>65</sup> Baseline asthma guidelines strongly advocate against LABA monotherapy and EIB guidelines are similar in this regard.<sup>52,56</sup> There is strong evidence to suggest that LABAs are effective in patients with asthma that is poorly controlled on inhaled steroids alone.<sup>52</sup> EIA

TABLE 36-1 Available Treatments for Exercise-Induced Asthma

Pharmacologic	Non-Pharmacologic and Dietary
Short-acting $\beta$ -agonists	Warm-up period
Inhaled corticosteroids	Face and inspirate warming
Leukotriene receptor antagonists	Omega-3 fatty acid supplementation
Anticholinergics	Low salt diet
Long-acting $\beta$ -agonists	
Mast cell stabilizing agents	

guidelines have avoided specifically making recommendations about LABA use in patients who are poorly controlled at baseline with respect to underlying asthma on inhaled steroids alone. Given the evidence that LTRAs are effective as adjuncts to inhaled steroids (when compared to LABAs), practitioners should strongly consider LTRAs before LABAs as add-on agents in patients for whom EIB has notably high impact.<sup>66</sup>

Mast cell stabilizing agents (MCSAs) have been demonstrated to prevent EIB. While their use has fallen out of favor as a controller for baseline asthma, they remain a mainstay in many parts of the world for EIA. As with LTRAs, these medications are recommended in EIA that is not controlled on SABAs alone.<sup>56</sup> Despite their efficacy, limited availability in the USA makes acquisition by patients a huge challenge.

Anticholinergics have long been used to prevent EIA and EIB. They are particularly recommended for use in patients with increased baseline vagal tone. Since this assessment is not readily available in clinical settings, and since elite athletes are considered to have increased vagal tone, it may be reasonable to strongly consider these medications in highly competitive athletes. One advantage is the widespread availability of these medications, including combination preparations with SABAs.

For reasons related to the feasibility of conducting clinical trials, there may never be definitive evidence for the preferred

medication for EIA (LTRA, MCSA or anticholinergics) in patients failing SABAs and inhaled steroids. One can imagine the challenge and expense of trying to find a sufficient number of patients failing these medications as documented by exercise or surrogate challenge to participate in a four-treatment (including placebo) cross-over trial. With this in mind, practitioners must rely on judgment to sequentially select medications empirically. One therapeutic strategy was presented in the 2012 American Thoracic Society Clinical Practice Guideline on EIA (Figure 36-2).<sup>56</sup>

In addition to medications which blunt EIA, there are a number of behavioral and dietary interventions that may be employed to improve performance. While each of these interventions comes at low financial cost, the decision to use these strategies should be based on comparisons between the burden of symptoms and the burden of treatment.

The refractory period has been used for decades to improve athletic performance and decrease symptoms. Given our evolving knowledge about cross-refractoriness, it may not be necessary to actually exercise in order to induce refractoriness (and voluntary hyperventilation could be used as an alternative). In practice, however, exercise is still the most widely-used method to induce refractoriness. Generally, patients perform a vigorous warm up that is sufficient to induce high rates of ventilation 45

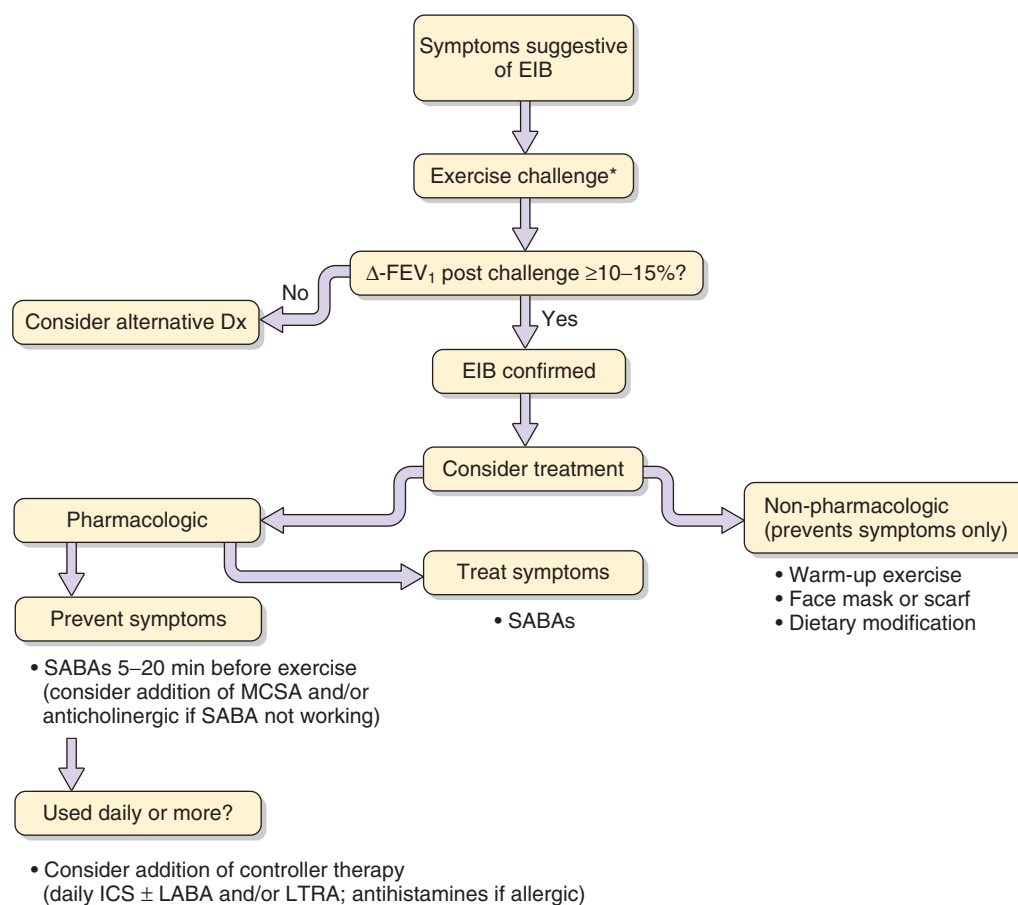

**Figure 36-2** Diagnostic and treatment algorithm for exercise-induced bronchoconstriction (EIB). LABA – long-acting  $\beta_2$ -agonist; LTRA – leukotriene receptor antagonist; MCSA – mast cell stabilizing agent; SABA – short-acting  $\beta$ -agonist; Dx – diagnosis; FEV<sub>1</sub> – forced expiratory volume in 1 second. \*Or surrogate challenge, e.g. hyperpnea or mannitol. (From Parsons JP, Hallstrand TS, Mastrorarde JG, Kaminsky DA, Rundell KW, Hull JH et al. An official American Thoracic Society clinical practice guideline: exercise-induced bronchoconstriction. *Am J Respir Crit Care Med* 2013;187(9):1016–27. Copyright © 2013 by the American Thoracic Society, reproduced.)

to 60 minutes prior to participation in the event of interest. Since bronchospasm is not required to induce refractoriness, SABAs (which generally maintain efficacy for 3 hours) may be used prior to the warm up. Many specific strategies have been employed for the warm up (including 6-minute jogs at speeds sufficient to produce a heart rate in the 140–150 range, as well as interval sprints). For the most part, patients can fully recover from a fatigue standpoint before the event of interest. Patients are often asked to trial a number of strategies in order to optimize performance.

Masks and headgear which can warm the face and inspired air as well as humidify inspired air can be helpful. This strategy presumably works by decreasing the osmotic stimulus of exercise in cold conditions, but may also work through blunting vagal stimuli as well.

Dietary changes, including increased omega-3 fatty acids, low salt diets, and high vitamin C have been proposed as adjunctive therapies for EIA. Omega-3 acids demonstrate efficacy in blunting EIA, as does a low salt diet (which appeared to demonstrate a dose-dependent effect).<sup>67,68</sup> There is also some limited evidence to suggest that vitamin C can help blunt EIB.<sup>69</sup>

In summary, many therapies exist for EIA, but guidelines recommending specific preferred medications in patients failing SABAs and inhaled corticosteroids are unlikely in the near future. Despite the number of available medications, practitioners should remember that only rare patients require more than a few of these medications to control EIA. As the number of medications used increases, so should the tendency to search for alternative diagnoses.

## Areas for Future Research

As EIA is an intermittent phenomenon, it presents challenges to researchers. However, as molecular research techniques improve, so should our understanding of EIA. Several fundamental questions about the nature of EIA remain unanswered.<sup>70</sup> Among these are:

- Is EIA one disease or many? Can we phenotype different groups of patients with EIB based on clinical or inflammatory features?
- Assuming that the ventilation associated with vigorous exercise induces epithelial stress, why do some athletes develop EIB and others do not? Can genetic studies help answer this question?
- What is the role of lipid mediators in EIA and refractoriness?
- What are the anatomical, epithelial or inflammatory causes for the severe EIA in certain children?
- Can environmental modification with regard to chemical exposure during swimming improve EIA?
- Can therapeutic strategies targeted toward the epithelium offer benefit in EIA?

## Summary

Bronchospasm is a common phenomenon in patients with and without underlying asthma. It is a particular problem in winter sport athletes, swimmers and children. It can have considerable impact on exercise performance and may affect the likelihood that casual exercisers will participate in cardiovascular activities. Bronchospasm occurs after osmotic and other epithelial stress trigger a cascade of mediators, including cysLTs. It is a condition that can be commonly confused with other causes of dyspnea, most notably paradoxical vocal fold motion. Diagnosis depends on measurement of inducible expiratory airflow limitation and surrogate challenges are becoming increasingly available for exercise. Several therapeutic options exist, but short-acting  $\beta$ -agonists prior to exercise and control of underlying asthma remain the mainstays of therapy. Improved molecular research techniques will hopefully improve patient quality of life through the development of improved diagnostic and therapeutic tools.

The complete reference list can be found on the companion Expert Consult website at <http://www.expertconsult.inkling.com>.

## KEY REFERENCES

- Carlsen KH, Anderson SD, Bjermer L, Bonini S, Brusasco V, Canonica W, et al. Exercise-induced asthma, respiratory and allergic disorders in elite athletes: epidemiology, mechanisms and diagnosis: part I of the report from the Joint Task Force of the European Respiratory Society (ERS) and the European Academy of Allergy and Clinical Immunology (EAACI) in cooperation with GA2LEN. *Allergy* 2008;63:387–403.
- Stern DA, Morgan WJ, Halonen M, Wright AL, Martinez FD. Wheezing and bronchial hyper-responsiveness in early childhood as predictors of newly diagnosed asthma in early adulthood: a longitudinal birth-cohort study. *Lancet* 2008; 372:1058–64.
- Glazebrook C, McPherson AC, Macdonald IA, Swift JA, Ramsay C, Newbould R, et al. Asthma as a barrier to children's physical activity: implications for body mass index and mental health. *Pediatrics* 2006;118:2443–9.
- Hallstrand TS, Moody MW, Wurfel MM, Schwartz LB, Henderson WR Jr, Aitken ML. Inflammatory basis of exercise-induced bronchoconstriction. *Am J Respir Crit Care Med* 2005;172:679–86.
- Larsson J, Anderson SD, Dahlen SE, Dahlen B. Refractoriness to exercise challenge: a review of the mechanisms old and new. *Immunol Allergy Clin North Am* 2013;33:329–45, viii.
- Langdeau JB, Turcotte H, Desagne P, Jobin J, Boulet LP. Influence of sympatho-vagal balance on airway responsiveness in athletes. *Eur J Appl Physiol* 2000;83:370–5.
- van Leeuwen JC, Driessen JM, de Jongh FH, van Aalderen WM, Thio BJ. Monitoring pulmonary function during exercise in children with asthma. *Arch Dis Child* 2011;96:664–8.
- Parsons JP, Hallstrand TS, Mastronarde JG, Kaminsky DA, Rundell KW, Hull JH, et al. An official American Thoracic Society clinical practice guideline: exercise-induced bronchoconstriction. *Am J Respir Crit Care Med* 2013;187:1016–27.
- Carlsen KH, Anderson SD, Bjermer L, Bonini S, Brusasco V, Canonica W, et al. Treatment of exercise-induced asthma, respiratory and allergic disorders in sports and the relationship to doping: Part II of the report from the Joint Task Force of European Respiratory Society (ERS) and European Academy of Allergy and Clinical Immunology (EAACI) in cooperation with GA(2)LEN. *Allergy* 2008;63:492–505.
- Hallstrand TS, Kippelen P, Larsson J, Bougault V, van Leeuwen JC, Driessen JM, et al. Where to from here for exercise-induced bronchoconstriction: the unanswered questions. *Immunol Allergy Clin North Am* 2013;33:423–42, ix.

## REFERENCES

- Akinbami LJ, Moorman JE, Bailey C, Zahran HS, King M, Johnson CA, et al. Trends in asthma prevalence, health care use, and mortality in the United States, 2001–2010. *NCHS Data Brief* 2012;1–8.
- Masoli M, Fabian D, Holt S, Beasley R. The global burden of asthma: executive summary of the GINA Dissemination Committee report. *Allergy* 2004;59:469–78.
- Kausel L, Boneberger A, Calvo M, Radon K. Childhood asthma and allergies in urban, semi-urban, and rural residential sectors in Chile. *Sci World J* 2013;2013:937935.
- Vital signs: asthma prevalence, disease characteristics, and self-management education: United States, 2001–2009. *MMWR Morb Mortal Wkly Rep* 2011;60:547–52.
- Cropp GJ. Grading, time course, and incidence of exercise-induced airway obstruction and hyperinflation in asthmatic children. *Pediatrics* 1975;56(5 pt–2 Suppl.):868–79.
- Hamilton BE, Martin JA, Ventura SJ. Births: preliminary data for 2012. *Natl Vital Stat Rep* 2013;62:1–20.
- Joshi S, Powell T, Watkins WJ, Drayton M, Williams EM, Kotecha S. Exercise-induced bronchoconstriction in school-aged children who had chronic lung disease in infancy. *J Pediatr* 2013;162:813–18, e1.
- Mannix ET, Roberts M, Fagin DP, Reid B, Farber MO. The prevalence of airways hyperresponsiveness in members of an exercise training facility. *J Asthma* 2003;40:349–55.
- Bougault V, Turmel J, Boulet LP. Bronchial challenges and respiratory symptoms in elite swimmers and winter sport athletes: airway hyperresponsiveness in asthma: its measurement and clinical significance. *Chest* 2010;138(2 Suppl.):31S–7S.
- Wilber RL, Rundell KW, Szmedra L, Jenkinson DM, Im J, Drake SD. Incidence of exercise-induced bronchospasm in Olympic winter sport athletes. *Med Sci Sports Exerc* 2000;32:732–7.
- Carlsen KH, Anderson SD, Bjermer L, Bonini S, Brusasco V, Canonica W, et al. Exercise-induced asthma, respiratory and allergic disorders in elite athletes: epidemiology, mechanisms and diagnosis: part I of the report from the Joint Task Force of the European Respiratory Society (ERS) and the European Academy of Allergy and Clinical Immunology (EAACI) in cooperation with GA2LEN. *Allergy* 2008;63:387–403.
- Addo-Yobo EO, Woodcock A, Allotey A, Baffoe-Bonnie B, Strachan D, Custovic A. Exercise-induced bronchospasm and atopy in Ghana: two surveys ten years apart. *PLoS Med* 2007;4:e70.
- Kukafka DS, Lang DM, Porter S, Rogers J, Ciccolella D, Polansky M, et al. Exercise-induced bronchospasm in high school athletes via a free running test: incidence and epidemiology. *Chest* 1998;114:1613–22.
- Stern DA, Morgan WJ, Halonen M, Wright AL, Martinez FD. Wheezing and bronchial hyperresponsiveness in early childhood as predictors of newly diagnosed asthma in early adulthood: a longitudinal birth-cohort study. *Lancet* 2008;372:1058–64.
- Becker JM, Rogers J, Rossini G, Mirchandani H, D'Alonzo GE Jr. Asthma deaths during sports: report of a 7-year experience. *J Allergy Clin Immunol* 2004;113:264–7.
- Vahlkvist S, Pedersen S. Fitness, daily activity and body composition in children with newly diagnosed, untreated asthma. *Allergy* 2009;64:1649–55.
- Glazebrook C, McPherson AC, Macdonald IA, Swift JA, Ramsay C, Newbould R, et al. Asthma as a barrier to children's physical activity: implications for body mass index and mental health. *Pediatrics* 2006;118:2443–9.
- Santos-Silva R, Melo C, Goncalves D, Coelho J, Carvalho F. Comparison between exercise performance in asthmatic children and healthy controls—Physical Activity Questionnaire application. *Rev Port Pneumol* 2014;20:138–45.
- Dantas FM, Correia MA Jr, Silva AR, Peixoto DM, Sarinho ES, Rizzo JA. Mothers impose physical activity restrictions on their asthmatic children and adolescents: an analytical cross-sectional study. *BMC Public Health* 2014;14:287.
- Wilmot EGE. Sedentary time in adults and the association with diabetes, cardiovascular disease and death: systematic review and meta-analysis. *Diabetologia* 2013;55:2895–905.
- Hallstrand TS, Curtis JR, Aitken ML, Sullivan SD. Quality of life in adolescents with mild asthma. *Pediatr Pulmonol* 2003;36:536–43.
- Weiler JM, Layton T, Hunt M. Asthma in United States Olympic athletes who participated in the 1996 Summer Games. *J Allergy Clin Immunol* 1998;102:722–6.
- Gilbert IA, McFadden ER Jr. Airway cooling and rewarming. The second reaction sequence in exercise-induced asthma. *J Clin Invest* 1992;90:699–704.
- Hallstrand TS, Moody MW, Wurfel MM, Schwartz LB, Henderson WR Jr, Aitken ML. Inflammatory basis of exercise-induced bronchoconstriction. *Am J Respir Crit Care Med* 2005;172:679–86.
- Bolger C, Tufveson E, Sue-Chu M, Devereux G, Ayres JG, Bjermer L, et al. Hyperpnea-induced bronchoconstriction and urinary CC16 levels in athletes. *Med Sci Sports Exerc* 2011;43:1207–13.
- Barreto M, Villa MP, Olita C, Martella S, Ciabattini G, Montuschi P. 8-Isoprostane in exhaled breath condensate and exercise-induced bronchoconstriction in asthmatic children and adolescents. *Chest* 2009;135:66–73.
- Hallstrand TS, Chi EY, Singer AG, Gelb MH, Henderson WR Jr. Secreted phospholipase A2 group X overexpression in asthma and bronchial hyperresponsiveness. *Am J Respir Crit Care Med* 2007;176:1072–8.
- Duong M, Subbarao P, Adelroth E, Obminski G, Strinich T, Inman M, et al. Sputum eosinophils and the response of exercise-induced bronchoconstriction to corticosteroid in asthma. *Chest* 2008;133:404–11.
- Lai Y, Altemeier WA, Vandree J, Piliponsky AM, Johnson B, Appel CL, et al. Increased density of intraepithelial mast cells in patients with exercise-induced bronchoconstriction regulated through epithelially derived thymic stromal lymphopoietin and IL-33. *J Allergy Clin Immunol* 2014;133:1448–55.
- Carraro S, Corradi M, Zanconato S, Alinovi R, Pasquale MF, Zacchello F, et al. Exhaled breath condensate cysteinyl leukotrienes are increased in children with exercise-induced bronchoconstriction. *J Allergy Clin Immunol* 2005;115:764–70.
- Hallstrand TS, Moody MW, Aitken ML, Henderson WR Jr. Airway immunopathology of asthma with exercise-induced bronchoconstriction. *J Allergy Clin Immunol* 2005;116:586–93.
- Meltzer SS, Hasday JD, Cohn J, Bleecker ER. Inhibition of exercise-induced bronchospasm by zileuton: a 5-lipoxygenase inhibitor. *Am J Respir Crit Care Med* 1996;153:931–5.
- Pearlman DS, van Adelsberg J, Philip G, Tilles SA, Busse W, Hendeles L, et al. Onset and duration of protection against exercise-induced bronchoconstriction by a single oral dose of montelukast. *Ann Allergy Asthma Immunol* 2006;97:98–104.
- Currie GP, Haggart K, Lee DK, Fowler SJ, Wilson AM, Brannan JD, et al. Effects of mediator antagonism on mannitol and adenosine monophosphate challenges. *Clin Exp Allergy* 2003;33:783–8.
- Dahlen B, Roquet A, Inman MD, Karlsson O, Naya I, Anstren G, et al. Influence of zafirlukast and loratadine on exercise-induced bronchoconstriction. *J Allergy Clin Immunol* 2002;109:789–93.
- Tahan F, Saraymen R, Gumus H. The role of lipoxin A4 in exercise-induced bronchoconstriction in asthma. *J Asthma* 2008;45:161–4.
- Larsson J, Anderson SD, Dahlen SE, Dahlen B. Refractoriness to exercise challenge: a review of the mechanisms old and new. *Immunol Allergy Clin North Am* 2013;33:329–45, viii.
- Hallstrand TS, Debley JS, Farin FM, Henderson WR Jr. Role of MUC5AC in the pathogenesis of exercise-induced bronchoconstriction. *J Allergy Clin Immunol* 2007;119:1092–8.
- Kiviloog J. The effect of pretreatment with atropine in exercise-induced bronchoconstriction. *Pediatrics* 1975;56(5 pt–2 Suppl.):940–1.
- Knopfli BH, Bar-Or O, Araujo CG. Effect of ipratropium bromide on EIB in children depends on vagal activity. *Med Sci Sports Exerc* 2005;37:354–9.
- Langdeau JB, Turcotte H, Desagne P, Jobin J, Boulet LP. Influence of sympatho-vagal balance on airway responsiveness in athletes. *Eur J Appl Physiol* 2000;83:370–5.
- Doeing DC, Solway J. Airway smooth muscle in the pathophysiology and treatment of asthma. *J Appl Physiol* 2013;114:834–43.
- Belcher NG, Murdoch R, Dalton N, Clark TJ, Rees PJ, Lee TH. Circulating concentrations of histamine, neutrophil chemotactic activity, and catecholamines during the refractory period in exercise-induced asthma. *J Allergy Clin Immunol* 1988;81:100–10.
- Hawksworth RJ, O'Hickey SP, Lee TH. The effects of indomethacin on the refractory period to hypertonic saline-induced bronchoconstriction. *Eur Respir J* 1992;5:963–6.
- Rundell KW, Im J, Mayers LB, Wilber RL, Szmedra L, Schmitz HR. Self-reported symptoms and exercise-induced asthma in the elite athlete. *Med Sci Sports Exerc* 2001;33:208–13.
- van Leeuwen JC, Driessen JM, de Jongh FH, van Aalderen WM, Thio BJ. Monitoring pulmonary function during exercise in children with asthma. *Arch Dis Child* 2011;96:664–8.
- Wilson BA, Bar-Or O, Seed LG. Effects of humid air breathing during arm or treadmill exercise on exercise-induced bronchoconstriction and refractoriness. *Am Rev Respir Dis* 1990;142:349–52.
- Knopfli BH, Luke-Zeitoun M, von Duvillard SP, Burki A, Bachlechner C, Keller H. High incidence of exercise-induced bronchoconstriction



- in triathletes of the Swiss national team. *Br J Sports Med* 2007;41:486–91, discussion 91.
49. Rundell KW, Sue-Chu M. Air quality and exercise-induced bronchoconstriction in elite athletes. *Immunol Allergy Clin North Am* 2013;33:409–21, ix.
  50. Bernard A, Nickmilder M, Voisin C, Sardella A. Impact of chlorinated swimming pool attendance on the respiratory health of adolescents. *Pediatrics* 2009;124:1110–18.
  51. Kruger SJ, Niles DJ, Dardzinski B, Harman A, Jarjour NN, Ruddy M, et al. Hyperpolarized Helium-3 MRI of exercise-induced bronchoconstriction during challenge and therapy. *J Magn Reson Imaging* 2014;39:1230–7.
  52. From the Global Strategy for Asthma Management and Prevention, Global Initiative for Asthma (GINA), <<http://www.ginasthma.org/>>; 2014.
  53. Olin JT, Clary MS, Connors D, Abbott J, Brugman S, Deng Y, et al. Glottic configuration in patients with exercise-induced stridor: a new paradigm. *Laryngoscope* 2014;124:2568–73.
  54. Dempsey JAJ. Exercise-induced arterial hypoxemia. *J Appl Physiol* 1985;87:1997–2006.
  55. Godfrey S, Springer C, Bar-Yishay E, Avital A. Cut-off points defining normal and asthmatic bronchial reactivity to exercise and inhalation challenges in children and young adults. *Eur Respir J* 1999;14:659–68.
  56. Parsons JP, Hallstrand TS, Mastrorarde JG, Kaminsky DA, Rundell KW, Hull JH, et al. An official American Thoracic Society clinical practice guideline: exercise-induced bronchoconstriction. *Am J Respir Crit Care Med* 2013;187:1016–27.
  57. Rundell KW, Wilber RL, Szmedra L, Jenkinson DM, Mayers LB, Im J. Exercise-induced asthma screening of elite athletes: field versus laboratory exercise challenge. *Med Sci Sports Exerc* 2000;32:309–16.
  58. Eliasson AH, Phillips YY, Rajagopal KR, Howard RS. Sensitivity and specificity of bronchial provocation testing. An evaluation of four techniques in exercise-induced bronchospasm. *Chest* 1992;102:347–55.
  59. Mannix ET, Manfredi F, Farber MO. A comparison of two challenge tests for identifying exercise-induced bronchospasm in figure skaters. *Chest* 1999;115:649–53.
  60. Brannan JD, Koskela H, Anderson SD, Chew N. Responsiveness to mannitol in asthmatic subjects with exercise- and hyperventilation-induced asthma. *Am J Respir Crit Care Med* 1998;158:1120–6.
  61. Carlsen KH, Anderson SD, Bjermer L, Bonini S, Brusasco V, Canonica W, et al. Treatment of exercise-induced asthma, respiratory and allergic disorders in sports and the relationship to doping: Part II of the report from the Joint Task Force of European Respiratory Society (ERS) and European Academy of Allergy and Clinical Immunology (EAACI) in cooperation with GA(2)LEN. *Allergy* 2008;63:492–505.
  62. Bray SM, Fajt ML, Petrov AA. Successful treatment of exercise-induced anaphylaxis with omalizumab. *Ann Allergy Asthma Immunol* 2012;109:281–2.
  63. Shapiro GG. Effects of albuterol and procaterol on exercise-induced asthma. *Ann Allergy* 1990;65:273–6.
  64. Hancox RJ, Subbarao P, Kamada D, Watson RM, Hargreave FE, Inman MD. Beta2-agonist tolerance and exercise-induced bronchospasm. *Am J Respir Crit Care Med* 2002;165:1068–70.
  65. Ramage L, Lipworth BJ, Ingram CG, Cree IA, Dhillon DP. Reduced protection against exercise induced bronchoconstriction after chronic dosing with salmeterol. *Respir Med* 1994;88:363–8.
  66. Lemanske RF Jr, Mauger DT, Sorkness CA, Jackson DJ, Boehmer SJ, Martinez FD, et al. Step-up therapy for children with uncontrolled asthma receiving inhaled corticosteroids. *N Engl J Med* 2010;362:975–85.
  67. Mickleborough TD, Vaughn CL, Shei RJ, Davis EM, Wilhite DP. Marine lipid fraction PCSO-524 (lyprinol/omega XL) of the New Zealand green lipped mussel attenuates hyperpnea-induced bronchoconstriction in asthma. *Respir Med* 2013;107:1152–63.
  68. Mickleborough TD, Lindley MR, Ray S. Dietary salt, airway inflammation, and diffusion capacity in exercise-induced asthma. *Med Sci Sports Exerc* 2005;37:904–14.
  69. Hemila H. Vitamin C may alleviate exercise-induced bronchoconstriction: a meta-analysis. *BMJ Open* 2013;3.
  70. Hallstrand TS, Kippelen P, Larsson J, Bougault V, van Leeuwen JC, Driessen JM, et al. Where to from here for exercise-induced bronchoconstriction: the unanswered questions. *Immunol Allergy Clin North Am* 2013;33:423–42, ix.

# Refractory Childhood Asthma: Assessment and Management

ANDREW BUSH

## KEY POINTS

- Problematic, severe asthma comprises wrong diagnosis ('not asthma at all'), asthma with co-morbidities ('asthma plus'), difficult asthma and true severe, therapy-resistant asthma. These patients should undergo a detailed, protocolized series of investigations.
- More than 50% of children referred to tertiary centers with problematic severe asthma in fact will be well controlled if basic management is optimal; they do not require therapy with 'beyond guidelines' medications.
- Invasive investigation should be considered in children with apparent severe, therapy-resistant asthma to determine whether there is discordance between symptoms and inflammation; whether there is an unusual pattern of inflammation; whether the child is steroid responsive and to what extent; and whether there is fixed airflow limitation.
- Unlike adult severe asthma, pediatric severe, therapy-resistant asthma is characterized by marked atopy and airway eosinophilia not neutrophilia, but without classic Th2 signature cytokine expression; the optimal monitoring strategy is unclear; sputum cellularity is much more variable over time and titrating treatment against sputum eosinophil count is not useful.
- There is little or no evidence base for 'beyond guidelines' therapy in children who fail standard therapies including omalizumab.

## Introduction

Refractory asthma is rare in childhood and probably accounts for less than 5% of all pediatric asthma.<sup>1</sup> It may be becoming less common over time, possibly because of more effective modern treatments.<sup>2</sup> However, this group accounts for an enormous amount of morbidity and healthcare costs, and even mortality, and so although rare, it is a very important topic. This chapter describes the assessment of children aged 6 years and older using the Royal Brompton Hospital approach to apparent refractory asthma. This personal practice is described as no evidence-driven approach exists. The reader is invited to judge the value of these protocols, as well as referring to a recent ERS/ATS guideline.<sup>3</sup> Finally, recent research advances are briefly summarized. Severe preschool wheeze is not discussed here.

## Refractory Asthma: Basic Principles

The cardinal sin in asthma management is to continue to escalate and intensify asthma therapy in a child who is not

responding to treatment, without posing the question, why is the prescribed treatment not working? We know that most children with asthma will respond very well to low-dose inhaled corticosteroids (ICSs) when properly administered, sometimes in combination with a second controller such as long-acting  $\beta_2$  agonists (LABAs) or leukotriene receptor antagonists (LTRAs).<sup>4</sup> So, when faced with a child with apparently refractory asthma, the pediatrician should not reach again for the prescription pad, but go through a rigorous protocol to determine what it is about the child and his/her asthma that means the anticipated response is not happening.

## Nomenclature

We use the term '*problematic severe asthma*' to describe children who, despite apparently optimal asthma management, have ongoing symptoms (Table 37-1).<sup>5-8</sup> It should be noted that this definition is arbitrary and not evidence based. Problematic severe asthma itself comprises four categories, the management of each of which is entirely different (Table 37-2).

The overall aim of these protocols is to determine if the individual child is truly a candidate for 'beyond guidelines' therapy or can be better managed by standard approaches.

An overlapping approach which is also a useful conceptual framework is to define risk by considering domains of asthma severity. These are:

1. Level of prescribed treatment
2. Level of baseline asthma control over the previous month
3. Burden and nature of exacerbations over the previous 6 to 12 months
4. Risk of future complications, including failure of normal airway growth (for which there is increasing evidence), risk of future loss of control and/or exacerbations; risk of medication side-effects.

## Approach to the Child with Problematic Severe Asthma

The first step is as always a full history and physical examination. Close attention should be paid to the nature of the symptoms. In particular, the word 'wheeze' is used very imprecisely, including being applied to crackling noises, upper airway noises and even stridor.<sup>9-13</sup> The possibility that the child does not in fact wheeze should be considered unless and until a physician has heard wheeze with a stethoscope.<sup>14</sup> Cough-variant asthma is a popular diagnosis, but most children who cough do not have asthma or indeed any other disease.<sup>15</sup> The decision as to whether to investigate further, and what tests to perform, is driven by findings on history and examination. The two classical errors are failure to document physician-heard wheeze and failure to document airflow obstruction which changes over

TABLE 37-1

### Criteria for 'Problematic Severe Asthma'. More than One of These Scenarios May be Encountered in the Same Child

- **Chronic symptoms:** (defined as the use of short-acting  $\beta_2$  agonists (SABAs) on at least 3 days a week for at least 3 months) despite inhaled corticosteroid (ICS\_ (beclomethasone equivalent [BDP] 800  $\mu\text{g}/\text{day}$ ) and the use of any combinations of long-acting  $\beta_2$ -agonists (LABAs), leukotriene receptor antagonists (LTRAs) and low-dose theophylline (or failed trials of at least two of these add-on therapies)
- **Severe asthma attacks:** any or all of: one admission to pediatric intensive care, the need for more than two intravenous treatments in the previous year, and the use of two or more prednisolone bursts in the previous year. This exacerbating pattern is not inevitably associated with poor background control
- **Airflow limitation:** FEV<sub>1</sub> of <80% after SABA withhold, or an FEV<sub>1</sub> of <80% despite a trial of systemic steroids and acute administration of SABA (persistent airflow limitation [PAL])
- **Disconnect of symptoms:** strictly, the child presenting with a multitude of symptoms with no objective evidence of uncontrolled disease may belong in a separate disease category, and certainly is not placed in severe asthma guidelines. Since the means of addressing this scenario are so very similar, inclusion in this group is pragmatically justified. The reverse scenario, underreporting of symptoms, is also considered

TABLE 37-2

### Differential Diagnosis of 'Problematic Severe Asthma'

1. **Not asthma at all:** the diagnosis is wrong
2. **Asthma plus:** there are associated co-morbidities which need to be addressed
3. **Difficult asthma:** accounts for about 50% of those in whom the first two categories have been excluded. This diagnosis comprises children who in fact need to get the basic steps of asthma management correct
4. **Severe, therapy-resistant asthma:** these children appear to have ongoing problems with asthma despite the optimization of all the basic steps of asthma management; such children are candidates for 'beyond guidelines' therapy

time or with treatment. There has been an increased interest in the diagnostic use of measurements of airway inflammation such as exhaled nitric oxide (FeNO), usually measured at a flow rate of 50 mL/s (FeNO<sub>50</sub>) and induced sputum cytospin. Although evidence of airway inflammation is not a mandatory diagnostic test for asthma, and in particular a child already on treatment with ICS may be inflammation free, absence of any evidence of airway inflammation in a child apparently symptomatic for asthma should prompt a diagnostic review. Finally, the diagnostic process should not end at this stage; the possibility of a wrong diagnosis should be at the forefront throughout, and further testing considered in the presence of a surprising finding such as airway neutrophilia (see below).

#### DOES THE CHILD ACTUALLY HAVE ASTHMA?

Numerous conditions may mimic asthma (Table 37-3). The likelihood of particular diagnoses will vary across the world. Important clues to an alternative diagnosis include neonatal onset of symptoms; chronic productive cough for many sequential weeks; and evidence of systemic disease. The nonatopic child

TABLE 37-3

### Differential Diagnoses of Severe Asthma

Class of Diagnosis	Examples
Local immunodeficiency	Cystic fibrosis, primary ciliary dyskinesia, persistent bacterial bronchitis
Systemic immunodeficiency	Any, including B cell and T cell dysfunction
Intraluminal bronchial obstruction	Foreign body, carcinoid, other tumor
Intramural bronchial obstruction	Bronchomalacia, complete cartilage rings, intramural tumor
Extraluminal bronchial obstruction	Vascular ring, pulmonary artery sling, congenital lung cyst, enlarged lymph nodes due to tumor or tuberculosis, other mediastinal masses
Direct aspiration	Bulbar or pseudobulbar palsy; laryngeal cleft
Aspiration by direct contamination	H-type fistula
Aspiration secondary to reflux	Any cause of gastroesophageal reflux, including hiatus hernia and esophageal dysmotility
Complications of prematurity	Bronchomalacia, structuring secondary to intubation, vocal cord palsy secondary to surgery for patent arterial duct
Congenital heart disease	Bronchial compression from enlarged cardiac chambers or great vessels; pulmonary edema
Interstitial lung disease	Any not presenting with neonatal respiratory failure
Dysfunctional breathing	Vocal cord dysfunction, hyperventilation syndromes

with apparently severe asthma should always be carefully assessed, since most such children have multiple positive skin prick tests and specific IgE, as well as a raised total IgE. A review of diagnostic testing for all the conditions listed in the Table 37-3 is beyond the scope of this chapter, but as a principle, testing should be focussed rather than take a scattergun approach.

#### ARE THERE SIGNIFICANT CO-MORBIDITIES WHICH NEED ADDRESSING?

A co-morbidity may not be easy to treat (e.g. obesity), but it is difficult to argue that potentially toxic biologicals are appropriate for a child who is not being supported by his/her family to lose weight. Co-morbidities have recently been reviewed in detail.<sup>16</sup>

#### Gastroesophageal Reflux

The possible relationships between asthma and respiratory symptoms, and gastroesophageal reflux are complex. Reflux can cause symptoms either by direct contamination of the lower airway or indirectly by an esophagobronchial reflex;<sup>17-19</sup> respiratory disease can cause reflux, including via mechanisms secondary to abnormal pleural pressure swings or configuration of the diaphragm; and reflux may be an asymptomatic fellow-traveler. The best evidence is that, irrespective of any symptoms suggestive of reflux, therapy with, for example, a proton pump inhibitor does not improve severe asthma;<sup>20-22</sup> and that has certainly

been our experience, despite hitherto performing pH-metry as part of our work-up for severe asthma.

### Rhinosinusitis

Upper airway disease worsens quality of life, and should be treated on its own merits in any context.<sup>23–25</sup> There is increasing evidence that treating rhinosinusitis may be beneficial at least in mild to moderate asthma.<sup>26</sup> The mechanisms of any benefit remain conjectural.<sup>27</sup> In our series, significant rhinosinusitis is unusual in severe asthma.

### Obesity

There are complex potential interactions between asthma and obesity. Obesity may cause breathlessness and ‘wheeze’ without evidence of asthma, leading to inappropriate treatment. Obesity may be associated with a pauci-inflammatory form of asthma, at least in adults, although it is sometimes unclear whether this is true asthma<sup>28</sup>; asthma with an eosinophilic phenotype on airway wall biopsy with raised sputum interleukin 5 (IL-5)<sup>29</sup>; and steroid resistance.<sup>30</sup> Obesity is a proinflammatory state,<sup>31</sup> as is obstructive sleep apnea (OSA) (see below).<sup>32</sup> Asthma (via reduced exercise performance) and its treatment (prednisolone bursts or long-term therapy) may cause or contribute to obesity. Hence, particular care is necessary before escalating therapy for ‘asthma’ in the obese child with respiratory symptoms. Weight reduction is always beneficial in the obese child, but is difficult to achieve.

### Upper Airway Obstruction/ Sleep Disordered Breathing

There is an increasing literature on asthma and OSA.<sup>33</sup> Although the literature reports associations in at least mild to moderate asthma, in our patients OSA is very rare in severe asthma, except in the presence of concomitant obesity (see above). We do not routinely perform polysomnography on children with severe asthma who are not obese. OSA was reported to cause sputum neutrophilia rather than eosinophilia in one study;<sup>34</sup> this inflammatory pattern rarely if ever occurs in true severe, therapy-resistant asthma, and if seen, should prompt a diagnostic re-evaluation.

### Dysfunctional Breathing

Vocal cord dysfunction and other forms of dysfunctional breathing are common in asthma,<sup>35</sup> although not all groups report this<sup>36</sup> and the symptoms are frequently misattributed to asthma, with inappropriate escalation of therapy. There is much less work in children than in adults.<sup>37–39</sup> Fifteen percent of children investigated following our protocol had evidence of dysfunctional breathing,<sup>40</sup> including hyperventilation and vocal cord dysfunction. Clues include the absence of symptoms at night, and often stridor rather than expiratory noises. An experienced respiratory physiotherapist should be asked to assess breathing pattern, and to treat an abnormal breathing pattern with a training program, although currently there is no randomized controlled trial evidence of benefit.<sup>35</sup> Parental video-recording of an attack may be illuminating. In older children, direct laryngoscopy during an exercise test enables direct demonstration of the problem. Dyspnea perception has been little studied in severe pediatric asthma,<sup>39</sup> but adults with severe asthma do not become as dyspneic as those with mild asthma during bronchoconstriction.<sup>41</sup> The possibility of poor symptom perception as a cause of an apparent sudden catastrophic deterioration should be borne in mind.

### Food Allergy

Atopy is almost inevitable in severe pediatric asthma, but patients with asthma and food allergy are over-represented in such cohorts.<sup>42,43</sup> Whether food allergy is causative of the problem or a marker is unclear; certainly anaphylaxis at rest and on exercise enters the differential diagnosis of acute severe asthma, and should always be considered because it is treatable. Food allergy should always be properly documented if exclusion diets are proposed; blind dietary exclusions are frequently tried and in our experience are of no benefit.

### NEXT STEPS: IS TRUE SEVERE, THERAPY-RESISTANT ASTHMA LIKELY?

Once it is clear that the diagnosis is almost certainly asthma, and co-morbidities have been excluded or identified, we proceed with a more detailed evaluation, led by the specialist asthma nurse and often involving the clinical psychologist and respiratory physiotherapist. The assessment will include both a hospital outpatient visit and a nurse-led community assessment, with the nurse arranging a visit to the family home and making contact with the school.<sup>40</sup>

### Hospital Visit

Details of the hospital visit are given in Table 37-4. We evaluate allergic sensitization by both skin prick tests (SPTs) and sIgE tests, because there is imperfect concordance (76–83%) between them.<sup>44,45</sup> This includes fungal sensitization<sup>44</sup>; because severe asthma with fungal sensitization [SAFS] (Table 37-5) has different treatment options (see below), we do not routinely perform double-blind food challenges. FeNO is measured ideally at multiple flow rates as an indirect assessment of proximal ( $J_{NO}$ ) and distal ( $C_{ALV}$ ) airway inflammation.<sup>46</sup> Although there is evidence that distal inflammation may be important in severe asthma (below), variable-flow FeNO has not been evaluated as a clinical tool to guide therapy in an individual child, so this is largely a research technique.

**TABLE 37-4 Assessments Performed at the Nurse-Led Hospital Visit**

Issue to be Addressed	Tests Performed
Symptom pattern	Asthma control test, prednisolone bursts, unscheduled visits
Psychosocial factors	Questionnaires
Lung function	Spirometry before and after bronchodilator
Allergic sensitization	Skin prick tests, specific IgE
Aeroallergens	Grass and tree pollen, house dust mite, cockroach, cat and dog, and any others suggested by the clinical history
Food allergens	Peanut, milk, egg and any others suggested by the clinical history
Fungi (see Table 37-5)	Fungi Table 37-3
Airway inflammation	FeNO <sub>50</sub> , multiple flow rates Induced sputum if FEV <sub>1</sub> is >70% predicted
Tobacco exposure	Urine or salivary cotinine
Medication adherence	Serum prednisolone and theophylline levels if prescribed; serum inhaled corticosteroid levels if available



**TABLE 37-5** Diagnostic Criteria for Severe Asthma with Fungal Sensitization (SAFS)

Adult Criteria	Proposed Pediatric Criteria*
Treatment with 500 µg fluticasone/day or continuous oral corticosteroids, or four prednisolone bursts in the previous 12 months or 12 in the previous 24 months, and	Meets criteria for problematic severe asthma (above)
IgE <1000 (exclude ABPA)	No IgE exclusion
Negative IgG precipitins to <i>Aspergillus fumigatus</i>	No IgG exclusion
Sensitization (SPT, sIgE) to at least one of <i>Aspergillus fumigatus</i> , <i>Alternaria alternata</i> , <i>Cladosporium herbarum</i> , <i>Penicillium chrysogenum</i> , <i>Candida albicans</i> , <i>Trichophyton mentagrophytes</i> and <i>Botrytis cinerea</i>	As adult criteria

\*There is no agreed definition in children, but given the rarity of allergic bronchopulmonary aspergillosis (ABPA) in children with asthma, we have proposed to eliminate the total IgE and IgG criteria, from the diagnostic criteria.

It should be remembered that children are not mini-adults. In particular, it should be noted that the interpretation of spirometry and imaging has a developmental perspective.

### Spirometry, Bronchodilator Responsiveness and Bronchial Challenge Testing.

Unlike in adults, spirometry is poorly discriminatory between asthma of different severities in children.<sup>47–49</sup> Spirometry is of course useful as part of the definition of an exacerbation, and to monitor progression of lung growth over time in epidemiological studies. Epidemiological evidence is that, for groups, spirometry in severe asthma tracks over decades,<sup>50–54</sup> but the pattern of lung growth may be abnormal in really severe asthma; for example, the Melbourne study showed a failure of the adolescent airway growth spurt.<sup>54</sup> There is other worrying evidence from studies showing that individuals with apparently good control of symptoms with ICSs may have abnormal airway growth over time.<sup>55–57</sup> One post hoc analysis suggested that this was related to the exacerbating phenotype, but only in patients not treated with ICSs.<sup>58</sup> This study requires prospective confirmation, but is in line with studies of other airway diseases showing so-called ‘exacerbations’ lead to a worse overall long-term outlook.<sup>59–63</sup> Bronchodilator responsiveness may be used diagnostically and to define persistent airflow limitation (PAL). Little has been written about bronchial challenge testing as a clinical tool in children with severe asthma. In many, it will be too hazardous because of poor baseline spirometry and/or extreme bronchial hyperreactivity. There is one situation in which direct airway challenge usually is useful in the diagnostic work-up, namely in a child with normal spirometry but reported severe symptoms, and in whom a negative challenge would make uncontrolled asthma unlikely. In such children, a combined protocol of hypertonic saline challenge and sputum induction<sup>64</sup> may be useful; in genuine severe asthma, the need for albuterol pretreatment before sputum induction as a safety measure precludes this approach. The role of challenge testing in children with PAL or obliterative bronchiolitis (OB), as part of confirmation that further escalation of therapy is not useful, is not clear; in all probability, a systemic steroid trial would be preferred.

### High-Resolution Computed Tomographic (HRCT) Scanning.

HRCT is not a routine part of our protocol, and there is no pediatric evidence to suggest the need for it. HRCT may be performed as part of the diagnostic work-up if, for example, the patient is nonatopic or bronchiectasis is suspected. However, in adult studies, bronchial wall dilatation is common in severe asthma,<sup>65,66</sup> and it is important not to over-diagnose bronchiectasis in children, in whom minor degrees of airway dilatation may be reversible, even when related to an immunodeficiency. It is essential to note that HRCT scans may be unable to distinguish severe asthma from OB.<sup>67</sup> In adults, but not in children, there is evidence that HRCT scans may be a useful biomarker of asthma severity.<sup>68,69</sup> In children, HRCT changes consistent with asthma are less apparent (and also less well defined) than in adults,<sup>70</sup> and bronchial wall thickening has no or only the weakest correlation with reticular basement membrane (RBM) thickening and forced expiratory volume in 1 second (FEV<sub>1</sub>).<sup>71–73</sup> Air trapping on HRCT may allow an estimate of distal airway disease,<sup>74,75</sup> but in severe asthma has not been compared with sophisticated tests of distal airway function such as lung clearance index.<sup>76–78</sup> There are no studies on the usefulness or otherwise of HRCT scans as a monitoring mechanism for severe pediatric asthma, and the radiation risk of even low-dose HRCT, especially in young children, is not a trivial consideration.

### Home Visit

The nurse-led home visit is a key part of the work-up of problematic, severe asthma.<sup>40</sup> Professors sitting in the clinic know little to nothing of what is really happening at home. Five areas are explored: adherence, tobacco smoke, allergens, psychosocial issues and asthma education. If the patient has been referred from a distant center, the home visit may be performed by a local specialist nurse after discussion with our own team. This approach may not be feasible everywhere, but in our hands, allows the identification of significant and potentially reversible factors in more than half of those referred with problematic severe asthma. It is certain that relying purely on a hospital-based assessment by a pediatrician will lead to many mistakes.

**Adherence.** This is discussed in detail in chapter 38. It was found that less than half of patients had picked up more than 80% of the required prescriptions, and nearly one third had picked up less than 50%.<sup>40</sup> We also enumerated the collection of excessive prescriptions of short-acting β<sub>2</sub>-agonists (SABAs); collecting ≥6 prescriptions/year is associated with a poor outcome.<sup>79</sup>

It was common to find that medication was past its expiry date; in 25% of cases a complete set of in-date medications could not be produced when the nurse visited. Other issues were total inaccessibility of any medications, and medications unopened in their original wrapping, neither of which inspired confidence that medications were actually being taken.<sup>40</sup>

**Parental Supervision.** In one study, even young children (20% of 7-year olds, 50% of 11-year olds) were left to take asthma medications unsupervised.<sup>80</sup> Often parents think they are supervising treatment, but do not in fact actually witness their child take the therapy, instead merely calling out reminders to their child who is in a different room in the home. This situation requires sensitive exploration.

**Use of Inhaler Devices.** These are often wrongly used and regular instruction in their use may lead to improvements.<sup>81,82</sup> However, even multiple teaching sessions are not enough to ensure good inhaler technique; all the children in our series had

had repeated instruction in specialized centers, and yet still had a poor technique. A common issue is using pressurized metered dose inhalers without spacers, because spacers are considered babyish; this omission guarantees minimal airway deposition of medications.

**Environmental Tobacco Smoke and Other Irritants.** Active smoking by adults with asthma causes steroid resistance,<sup>83–86</sup> and it seems likely that passive smoke exposure has the same effect. Passive smoke exposure is common in children with asthma;<sup>87–89</sup> the prevalence of active smoking is unknown, but unlikely to be low. We found that 25% of children with problematic, severe asthma were exposed to tobacco smoke.<sup>38</sup>

The mechanisms of tobacco smoke-induced steroid resistance have been researched mainly in adults;<sup>90</sup> the phenotype is neutrophilic. In a study of children with severe, therapy-resistant asthma,<sup>91</sup> we found that parental smoking reduced histone deacetylase protein expression and activity, and reduced the *in vitro* inhibitory effects of dexamethasone on tumor necrosis factor- $\alpha$ -induced IL-8 release from alveolar macrophages. Bronchoalveolar lavage (BAL) showed higher IL-8 concentrations and neutrophil counts and the children had lower asthma control test (ACT) scores compared with non-passive smoke-exposed children; these findings are supported by adult data. Additionally, it is also likely that symptoms are exacerbated by a direct irritant effect of smoke.

Other environmental irritants sometimes encountered include incense or joss sticks, and the extensive use of air fresheners and other aerosol sprays. Environmental pollution is also important, but difficult to modulate except at the level of public health.

**Allergen Exposure.** This is discussed in detail elsewhere. Allergen exposure in the home combined with evidence of sensitization has been clearly implicated in the etiology of viral-induced asthma attacks.<sup>92</sup>

In our study,<sup>38</sup> 17 of 30 children who owned furry pets were sensitized to that pet on skin prick testing; only two had any allergen avoidance precautions in place. Thirty-one children were thought to have clinically significant house dust mite (HDM) exposure; five were using comprehensive allergen avoidance measures, 15 partial and 11 none. Reduction of mold exposure may be particularly important if SAFS (see above) is suspected. Allergen exposure in school may also be important, but this is an even more difficult area in which to intervene.

**Psychosocial Issues.** Acute and chronic stress may trigger asthma exacerbations;<sup>93–95</sup> there may be quite complex time relationships between the two. Stress has been shown to amplify the airway eosinophilic response to allergen challenge.<sup>96</sup> In our study,<sup>38</sup> psychosocial issues were common, especially anxiety and depression, a finding reported by others.<sup>97</sup> Most issues only emerged during discussions in the home. Altogether, about half the families were referred to clinical psychology for a more detailed assessment. It is not productive to try to determine whether anxiety and depression are the cause or result of severe asthma; both are treated on their individual merits.

**Asthma Education.** Some adherence issues relate to basic misunderstandings of the purpose of treatment, and these are also addressed. If the child does not have a detailed asthma plan, this is put in place and communicated to the school. It is to be hoped

that all this will have been done previously, but any gaps are sought and closed.

### *Lesson Learned the Hard Way*

**School Visit.** Despite the best efforts of my specialist respiratory nurses, I have made many mistakes. The importance of contact with the school cannot be overemphasized. Teachers are an important resource; they are experienced in assessing children and spend many hours each day with them. If there is any suspicion that symptoms are being overcalled by the parents, talk to the teacher. In one particularly egregious case (details modified to preserve patient confidentiality) a girl with so-called severe asthma was in fact the captain of field hockey, had the nickname of ‘the Greyhound’ and her teachers did not know that she even had asthma, let alone that a reserve supply of SABA was kept for her!

**Management of Exacerbations.** In theory, the treatment of an asthma attack is based on objective evidence of present symptoms. In practice, the previous history is influential. When assessing the child with apparent multiple severe exacerbations, it is essential to determine what (if any) objective assessments were carried out before instituting treatment, and whether or not the level of treatment was objectively justified. One child under our care was actually started on intravenous albuterol despite being fully saturated on room air!

**Parental Doublespeak.** The basic tenet of pediatrics is to believe the parents. On occasion, parents not telling the truth may be the underlying problem, and this is very difficult to detect. This is distinct from the effect of a very understandable parental anxiety leading to exaggeration of symptoms. Motivation for the former may include access to financial and other benefits as a result of having a ‘sick’ child, right up to deliberate fabrication of symptoms (Munchausen by proxy). Unfortunately the result is often a long delay in diagnosis.

## MULTIDISCIPLINARY TEAM DISCUSSION

The assessment generates a mass of detailed information, and this is next assessed in a dedicated, multidisciplinary team meeting. We aim to determine whether the child has difficult asthma for which the basic management steps need to be addressed, or potentially severe, therapy-resistant asthma, which justifies further invasive investigations.

### *Does the Child Have ‘Difficult Asthma’ or Severe, Therapy-Resistant Asthma?*

In more than half of the children, no further investigations are undertaken, or at least, invasive testing is deferred pending other interventions. This unfortunately does not mean the problem is necessarily solved; for example, it is one thing to identify poor adherence as an issue, but quite another to address it. Often, the child’s poor adherence to medication has not been appreciated by the parents, and identification of the problem leads to them finding a solution. Adherence may be addressed by giving the child an inhaler with a microchip to record when medication is taken. We never attempt deception, and always tell the child and family that a recording is being made. If the inhaler is used and the child improves, this is gratifying. However, it is still illuminating if the inhaler is not used and asthma symptoms continue unabated. We have sometimes used directly observed therapy at school, on the basis that 5 days of treatment a week is better than

none; if this is put in place, it is essential to check that the seemingly obvious, namely that therapy is directly observed, is actually happening. One child told us that the school nurse was always working at a desk with her back to the child when supposedly directly observing therapy!

Deferring investigations for psychological intervention are common. Psychological interventions may be effective.<sup>98</sup> In general, individualized plans work best.<sup>99–101</sup> Of course, these may be combined with the other interventions outlined above, and also with invasive investigations.

Addressing allergen exposure in the home is notoriously difficult, especially if the allergen concerned originates from a much-loved family pet (the English disease). Frequently, the cat will be sent away for a short time and then allowed to return because the child's asthma has not improved; however, at least a year's separation is necessary substantially to reduce the allergen load. We do not prescribe omalizumab to any child unless every effort to reduce the environmental allergen burden has been made.

The fact that many children with apparent severe asthma just need to get basic management right has been reported by others, and has been the bugbear of intervention study design; those with apparently severe asthma tend to melt away when proper, protocol-driven management is put in place.

The remainder of the children continue in the protocol as outlined in the next section.

**Is the Distinction Between 'Difficult Asthma' and 'Severe, Therapy-Resistant Asthma' Meaningful?** We have published follow-up data for 78 children.<sup>102</sup> Those assigned to the difficult asthma group were able to reduce their prescribed dose of ICS (although perhaps in reality they were actually taking it for the first time) while increasing their FEV<sub>1</sub> and having fewer prednisolone bursts than the children with severe, therapy-resistant asthma. This is in accord with the multifaceted intervention studies reported in those with less severe asthma.<sup>103,104</sup> The severe, therapy-resistant group had smaller increases in FEV<sub>1</sub> but were unable to reduce treatment. We concluded that the groups behaved differently, and the distinction was useful. We also assessed whether or not the two groups could be distinguished from basic measurements; however, although children with severe, therapy-resistant asthma had a lower FEV<sub>1</sub>% predicted, more bronchodilator reversibility and a higher FeNO<sub>50</sub> than those with difficult asthma, the overlap between the groups made placing all individuals into the correct category an impossibility. A similar result was reported by the Severe Asthma Research Program (SARP) group, namely statistically significant but clinically unreliable differences between severe and moderate asthma in terms of FEV<sub>1</sub> and FeNO<sub>50</sub>.<sup>105</sup>

**Research Implications.** The categorization into difficult and severe, therapy-resistant asthma has important implications for the interpretation of research studies, such as genetic association studies. Cohorts of children with 'severe asthma' who have not gone through a detailed filtering process will be diluted by at least 50% with children for whom the basics have simply not been addressed, and therefore may not be comparable to those with truly therapy-resistant asthma.

## INVASIVE TESTING

Typically children with severe, therapy-resistant asthma have very major problems with asthma (Table 37-6), thus justifying

**TABLE 37-6** Characteristics of Children with Severe, Therapy-Resistant Asthma

Parameter	Mean Result (range)
Symptoms (ACT)	13/25 (9–17)
Symptom duration (years)	10.1 (9.3–12.7)
Number intubated	11/53 or 21%
FEV <sub>1</sub> %predicted	69 (55–87)
Acute FEV <sub>1</sub> response to 1 mg of albuterol (%)	15.6 (5.5–23.4)
FeNO <sub>50</sub> (ppb)	50 (29–70)
Mean sputum eosinophils (%)	7.5 (3.2–30.4)

**TABLE 37-7** Four Key Questions Answered by Invasive Investigation of Children with Severe, Therapy-Resistant Asthma

1. Is there phenotype discordance: a disconnect between symptoms and airway inflammation? Anti-inflammatory medication is not escalated if the airway is not inflamed, and is intensified in an exacerbating child if there is airway inflammation when the child is asymptomatic
2. Is the airway inflamed at all, and if so, what is the pattern of inflammation?
3. Is the child partially or totally steroid responsive, or steroid resistant?
4. Does the child have persistent airflow limitation? Therapy for airflow obstruction is not escalated if the child has reached the plateau of the dose-response curve

an invasive approach.<sup>106</sup> There are a number of differences between the typical child with severe, therapy-resistant asthma and the adult with this diagnosis. In children, there is no female predominance, but a strong atopic history was common<sup>102,106</sup> (85% atopic with a total median IgE of 386 [115–1286]). The children are also not obese. Although we have published a number of research papers based on our bronchoscopic studies, the aim of testing is primarily clinical to answer four key questions (Table 37-7). An individualized treatment plan is devised on the basis of the answers to these questions.

### Protocol: Invasive Investigation of Severe, Therapy-Resistant Asthma

The child is assessed invasively and noninvasively on the same day. Noninvasive investigations are symptom assessment, spirometry and acute response to bronchodilator, sputum induction and FeNO measurement, as performed in the initial assessment. The child then undergoes a bronchoscopy under a general anesthetic, with performance of BAL and endobronchial biopsy, and often bronchial brushings as a research procedure, as described in detail elsewhere.<sup>106</sup> At the end of the procedure, we administer a single dose of intramuscular triamcinolone (40–80 mg depending on the size of the child). The child is kept in hospital overnight, even if a pH study is not to be performed. The child is then seen again 4 weeks later, and all the noninvasive measurements are repeated.

The key requirement for the safe performance of bronchoscopy in these children is a skilled anesthetist. The child may be premedicated with SABAs. Adverse events are very rare. We have seen acute severe bronchospasm on one occasion, which rapidly responded to treatment. Close post-procedure monitoring of the child is essential.



**Assessment of Airway Inflammation.** We do not see neutrophilic inflammation in children with severe asthma,<sup>106</sup> which is in marked contrast to what is seen in adults. Instead, induced sputum, BAL and endobronchial biopsy are eosinophil dominated, although there are marked variations between individuals in the extent of eosinophilia. Hence, a neutrophilic phenotype should prompt reconsideration of the diagnosis. There tends to be agreement between induced sputum and BAL, but discordance between these luminal compartments and the airway wall histology.<sup>107</sup> It is not clear which is most relevant to disease pathophysiology. The relationship between FeNO and airway eosinophilia is discussed below.

Given the marked eosinophilic phenotype, a Th2 cytokine profile would be expected, but two pediatric severe asthma studies have failed to confirm this. We studied induced sputum supernatant, BAL using both the Luminex and CBA platforms, and performed immunohistochemistry on endobronchial biopsies, and found scant evidence of the Th2 signature cytokines IL-4, IL-5 and IL-13.<sup>106</sup> The SARP group also failed to find evidence of Th2-driven inflammation.<sup>108</sup> They compared severe, therapy-resistant asthma with mild-moderate disease and showed that the cytokines which best discriminated between the two groups were GRO (CXCL1), RANTES (CCL5), IL-12, interferon-gamma (IFN- $\gamma$ ) and IL-10. They concluded that pediatric severe, therapy-resistant asthma was neither a Th1 nor a Th2-driven disease. Gene expression studies of the sort that have generated the Th2 high and low groups in adults have so far not been performed in children.<sup>109</sup> Whether those few children in whom Th2 cytokines are detectable (see above) are in fact Th2 high remains to be seen. In this context it should be noted that periostin, a useful serum biomarker in adults for the Th2 high phenotype, is not useful in children because it is released from growing bone.

The findings of these two large studies described above do not necessarily show that Th2 cytokines are unimportant in the pathophysiology of severe asthma. All children with severe, therapy-resistant asthma are by definition prescribed high-dose ICS, and it may be that the Th2 component of their disease is abrogated by this therapy. What these studies do suggest is that the factors driving ongoing disease are different from those in adults. Attention is shifting to the epithelial-derived cytokines (IL-25, IL-33, thymic stromal lymphopoietin [TSLP]) as possible candidates, perhaps interacting with innate lymphoid cells.<sup>110</sup> We have shown that IL-33 promoted collagen synthesis by fibroblasts from pediatric patients with severe asthma.<sup>111</sup> We also showed that increased cellular expression of IL-33, but not IL-13, was associated with increased reticular basement membrane thickness in endobronchial biopsies. IL-33 also stained strongly in the endobronchial biopsies. The results were supported by animal data. Also, a recent study of a monoclonal antibody (AMG 157), which prevents TSLP interacting with its receptor, led to marked attenuation of both the early and late phase allergen response in adults with mild asthma,<sup>112</sup> a surprising finding given that only a single cytokine was blocked.<sup>113</sup>

The Th17 pathway has been considered another candidate, at least in adults, but it possibly more likely drives a neutrophilic phenotype, and thus is an unlikely candidate in children. However, eosinophil chemoattraction by IL-17 has been reported, at least in animal models.<sup>114,115</sup> Furthermore, a recent trial of the monoclonal anti-IL-17 receptor antibody brodalumab in adults showed disappointing results.<sup>116</sup> Further work

is clearly needed in order to delineate the proinflammatory mechanisms driving pediatric severe, therapy-resistant asthma.

There is an important implication of the above findings. An increasing number of studies of anti-Th2 cytokine strategies, such as mepolizumab (anti-IL-5,<sup>117</sup> lebrikizumab (anti-IL-13)<sup>118</sup> and dupilumab (IL-4 receptor alpha chain)<sup>119</sup> have recruited children aged 12 years and older, although they are largely dominated by adult participants. It is essential that the promising results in these trials are not uncritically extrapolated to children. It may be justified to perform a therapeutic n-of-1 trial in a child doing badly on all therapies, but further trials in children are needed, including measurements of Th2 cytokines, before Th2 cytokine strategies can be widely recommended in pediatric severe, therapy-resistant asthma.

**Assessment of Steroid Responsiveness.** It is likely that steroid responsiveness is a continuum; true steroid unresponsiveness is likely confined to rare cases of mutations in the corticosteroid receptor. The widely accepted adult definition of steroid response<sup>120,121</sup> is  $\geq 15\%$  predicted increase in FEV<sub>1</sub> in patients with bronchodilator reversibility (BDR) of  $\geq 12\%$  from baseline and an abnormal FEV<sub>1</sub> ( $\leq 80\%$ ) prior to the trial. There is no accepted definition in children, and the adult definition cannot be applied to around half of our pediatric patients with severe, therapy-resistant asthma, mainly because their baseline spirometry is not sufficiently abnormal prior to the trial,<sup>106</sup> and also because spirometry is often a poor reflection of asthma severity in children (see above). Furthermore, there is no consensus on the dose and duration of corticosteroids for the trial. We opted to use triamcinolone intramuscularly to ensure adherence. We use a multimodality definition of steroid responsiveness (Table 37-8).<sup>122</sup> Most children are partial responders, about 10% are total nonresponders and 10% completely responsive in all domains (complete responders). Some children who were non-responsive according to the adult definition were partial responders in the multidomain assessment. We have also shown that additional doses of triamcinolone do not change the category of responsiveness (unpublished observations). While the clinical utility of this approach has yet to be confirmed, it might serve as a useful template for current research; so, for example, an intervention with an anti-inflammatory medication might be expected primarily to affect the inflammatory domain.

**Assessment of PAL.** The definition of PAL is relatively easy; FEV<sub>1</sub>  $< 80\%$  (or better,  $-1.96 Z$  [standard deviation] scores) despite a trial of systemic steroids and acute administration of SABAs. However, the dose, duration and route of administration of steroids has still to be agreed, as has the dose of SABAs. We have shown that neither 40 mg of prednisolone for 2 weeks<sup>123</sup> nor a single dose of triamcinolone combined with 1 mg albuterol inhaled from a large volume spacer<sup>124</sup> is adequate

**TABLE 37-8 Domains and Definition of Steroid Responsiveness**

Modality	Response
Symptoms	ACT $> 19/25$ or 50% increase
Spirometry	FEV <sub>1</sub> $> 80\%$ predicted or 15% increase
FeNO <sub>50</sub>	Falls to $< 24$ ppb
Sputum eosinophils	Falls to $< 2.5\%$



to determine whether the child has PAL, but it is doubtful that a higher or longer duration of systemic steroids can be justified. Thus, we have taken the pragmatic decision that PAL should be at least provisionally diagnosed after a single dose of triamcinolone and albuterol as above.

## Treatment of Pediatric Severe, Therapy-Resistant Asthma

The treatment options, with the exception of the use of omalizumab, are largely anecdotally based.<sup>125</sup> The following scheme is suggested.

1. *Is omalizumab indicated?* Much of the evidence for omalizumab is inevitably in less severe asthma,<sup>126–135</sup> but if the child meets national guidelines for asthma *and* has been assessed in detail as above and found to have persistent eosinophilic airway inflammation on bronchoscopy, *and* every effort has been made to reduce the allergen burden in his/her environment, then we recommend a 16-week trial of omalizumab, with detailed monitoring of the response. Although guidelines mandate aeroallergen sensitization, omalizumab may be trialed in the rare non-atopic child with IgE in the range for which omalizumab is indicated.<sup>136</sup> If after 16 weeks there is no benefit, we discontinue therapy.
2. *Should standard medications be used in novel ways?* Options are high-dose ICSs, fine particle ICSs, oral prednisolone and intramuscular triamcinolone; the SMART regimen (a single combination ICS and LABA device, usually a Symbicort Turbohaler™); and low-dose theophylline (anti-inflammatory dose) if not already used prior to referral. For all but the SMART regimen, demonstration of ongoing eosinophilic airway inflammation is essential. Steroid total nonresponders who have eosinophilic inflammation should only be considered for low-dose theophylline and not the steroid based regimens.
  - High-dose ICS: for most children, the plateau of the ICS dose response curve is 100 µg twice daily of fluticasone,<sup>4</sup> and escalation of dosing risks increased side-effects. However a small minority of children with asthma may benefit from increasing the dose to as high as 2000 µg/day.<sup>137</sup> However, if there is no response to dose escalation, it is essential that the ICS is promptly stepped down to the lowest possible dose.
  - Fine particle ICS: there is evidence from adult studies that some patients with asthma may have very distal inflammation on transbronchial biopsy (TBB).<sup>138–140</sup> These studies have not been performed in children because of fears of the risks of TBB. There is also physiological evidence from alveolar NO concentration ( $C_{alv}$ ) measurements of distal airway inflammation in adults with asthma, with response both symptomatically and physiologically to fine particle ICS or systemic steroids.<sup>141,142</sup> There is too much variability in  $C_{alv}$  for it to be used as a biomarker in individual children,<sup>46</sup> and there is no evidence for this approach in severe, therapy-resistant asthma. However, a trial of fine particle ICS may be worth considering, with its discontinuation if there is no benefit. Finally, it is interesting to speculate whether or not the distal airway inflammation is related to poor peripheral deposition of ICS, and might respond to low-dose oral prednisolone, delivering steroid by the blood-borne rather than the airborne route.
3. *Does the child meet criteria for SAFS?* The definition of SAFS is given in Table 37-5. The results of trials of itraconazole in adults are conflicting,<sup>154</sup> but voriconazole has shown benefit.<sup>155</sup> Fungal sensitization in children may be associated with a more severe phenotype,<sup>156</sup> but there are no randomized controlled trials of treatment. Our approach is first to minimize environmental fungal exposure in the home, including checking any nebulizer the child may have for fungal contamination, and banning visits to stables (by analogy with management of allergic bronchopulmonary aspergillosis in cystic fibrosis). If antifungals are to be used, it is essential to remember that these interact with ICSs, such that iatrogenic Cushing's syndrome may be seen.<sup>157–160</sup> Anecdotally, antifungals have been successful in some children.
4. *Should nonstandard medications be used?* The possible approaches are macrolide antibiotics, immunosuppressants, intravenous immunoglobulin as an immunomodulator, and a continuous subcutaneous infusion of terbutaline.
  - Macrolide antibiotics are the safest option, and may be indicated for the rare child with a neutrophilic phenotype, or if an atypical infection is suspected.<sup>161,162</sup> One study comparing azithromycin with montelukast as add-on therapy ended in futility,<sup>163</sup> as only 55 of the 292 who were symptomatic while prescribed ICSs and LABAs could be randomized; most of the rest were

- Oral prednisolone: the non-evidence-based starting dose is 0.5 mg/kg, tapering down to the lowest dose needed to control the disease. If this comes at the price of unacceptable side-effects, then a steroid-sparing agent (see below) should be considered.
- Intramuscular triamcinolone: there is no evidence that this offers any advantage other than in assuring adherence, which is an insufficient reason for using it other than for a steroid trial (see above). Indeed, if it is used as a 'quick fix' for nonadherence, there is a risk that the child will continue to use it long term with the risk of severe steroid side-effects.
- SMART regimen:<sup>143–145</sup> we use this simple approach particularly in adolescents, and also consider it in the child with symptoms and ongoing peak flow variability but without evidence of eosinophilic airway inflammation. It could be argued that a LABA as a single inhaler added to the child's base medications would be more logical, but given the risks of a LABA as a single agent, we prefer the compromise of the additional ICS. The risk of this strategy is that it relies on adequate symptom perception, which may not always be the case in children with severe asthma (see above).
- Low-dose theophylline: there is laboratory evidence, and data from adult studies, that theophylline in a dose aimed at serum levels of 5–10 µg/mL may have significant anti-inflammatory effects and restore steroid responsiveness, the latter making it particularly attractive in steroid complete nonresponders.<sup>146–153</sup> The lower serum levels reduce but do not eliminate the risk of drug interactions and other side-effects. Despite the strong theoretical background, this approach has rarely been successful in our hands.

nonadherent or did not have asthma at all, underscoring the need for detailed evaluation of these patients before uncritical acceptance of the diagnosis 'severe asthma'. However, in the small group who were actually studied, the results were not encouraging.

- Immunoglobulin infusions: the evidence is scanty in adults, and anecdotal and conflicting in children.<sup>164–167</sup> As with immunosuppressants, immunoglobulin infusions are used only in children with evidence of ongoing airway inflammation which is either steroid resistant or only responsive at the cost of major side-effects. One small study in teenagers with steroid-dependent asthma showed a reduction in maintenance oral steroids, steroid bursts and hospitalizations for asthma. The authors suggested that the mechanism may be a synergistic interaction with dexamethasone in suppressing lymphocyte activation and also significant improvement in the glucocorticoid receptor-binding affinity.<sup>168</sup>
  - Immunosuppressants are used in children on the basis of small case series (methotrexate,<sup>169,170</sup> cyclosporine<sup>171</sup>) or no published evidence (azathioprine). Nebulized cyclosporine may be an attractive way of deriving benefits while avoiding systemic toxicity, but has only been used after lung transplantation
  - Subcutaneous terbutaline infusions may be considered in children with ongoing documented labile airflow obstruction and no underlying airway inflammation.<sup>172</sup> This is a rare group, and the evidence base is a small case series. We now perform a double blind n-of-1 therapeutic trial, but rarely find any benefit.
5. *What about other biological agents?* The differences in pathophysiology between childhood and adult severe asthma have been highlighted above. Nonetheless, in a child who has persistent eosinophilic inflammation with ongoing symptoms, either totally steroid responsive or suffering major steroid side-effects, and particularly in the rare case of documented Th2 activation, a trial of one of the monoclonal Th2 strategies (see above) could be justified on compassionate grounds.
  6. *Physical methods?* There is no evidence to recommend bronchial thermoplasty in children, and indeed the potential long-term consequences of this procedure on the growing airway are a concern.

### A DIFFICULT SPECIFIC PROBLEM: TREATMENT OF THE EXACERBATING PHENOTYPE

Acute asthma exacerbations cause considerable morbidity, sometimes death, but are fortunately not a feature of all children with asthma. Exacerbations cannot be abolished completely. Exacerbation and loss of baseline control are not the same thing; loss of baseline control is characterized by wide diurnal peak expiratory flow variation and acute exacerbation by a steep decline in peak flow, with no increased variability.<sup>173</sup> Children may have good control, but still show exacerbations,<sup>174</sup> and increasing the doses of preventer and controller medications taken between exacerbations merely increases the risk side-effects. However, poor control<sup>175</sup> and previous severe exacerbations<sup>175,176</sup> both predict future acute exacerbations.

In older children, the combination of respiratory viral infection and both sensitization and exposure in the home to high allergen levels is strongly predictive of exacerbation.<sup>92</sup> These

patients are typically characterized by mixed eosinophilic and neutrophilic, or pure neutrophilic inflammation.<sup>177–179</sup> At the other extreme, very high allergen exposure can cause acute exacerbations (e.g. thunderstorm asthma<sup>180</sup> and the Barcelona soya bean epidemic asthma<sup>179</sup>) and thunderstorm asthma at least is characterized by airway eosinophilia.<sup>181</sup>

In school-age children with multiple exacerbations, we aim to increase the baseline dose of ICS to abolish interval sputum eosinophilia, the effects of which are best shown through the proof of concept anti-IL5 studies.<sup>182,183</sup> LABAs also reduce exacerbations.<sup>184–186</sup> Allergen sensitization is identified and avoidance measures advised. High-dose ICS<sup>187</sup> or LTRAs<sup>188</sup> may be considered at the first sign of a viral exacerbation. However, none of these measures will completely obviate the need for oral corticosteroids. Finally, if exacerbations are of very sudden onset, with rapid deterioration over minutes, we provide the child with a source of injectable epinephrine (Epipen™). The hospital treatment of acute exacerbations is beyond the scope of this chapter.

## Monitoring the Child with Severe, Therapy-Resistant Asthma on Treatment

### MONITORING TREATMENT BENEFIT

It might be thought on the basis of research in adults with asthma that monitoring therapy in the inflammatory phenotypes would be beneficial in children.<sup>189,190</sup> However, the only trial in children with severe, therapy-resistant asthma using induced sputum every 3 months to guide the dose of inhaled corticosteroids was negative.<sup>191</sup> While a post hoc analysis did suggest a reduction in acute asthma attacks in the month after the sputum measurement in children who were monitored using the sputum strategy, there is currently insufficient evidence to recommend induced sputum or FeNO<sub>50</sub> to monitor severe asthma. Two studies may help explain why this is the case. In the first of these, the variability of sputum phenotype longitudinally was determined in children with either mild/moderate or severe asthma, and spontaneous phenotype changes were common in both groups and not predictable. This is in marked contradistinction to results in adults who appear to be much more stable over time.<sup>192</sup> The second study reported the relationship between sputum eosinophil count and FeNO<sub>50</sub> in severe therapy-resistant asthma: 148 samples were concordant (eosinophil positive, FeNO<sub>50</sub> positive = 77; both negative = 71) and 49 (25%) were discordant (eosinophil positive, FeNO<sub>50</sub> negative = 25; eosinophil negative, FeNO<sub>50</sub> positive = 24). Fifty-nine children produced at least two sputum samples. Of these, 31 (53%) were consistently concordant, 24 (41%) were discordant in one sample but concordant on at least one other occasion (one showed discordance in both directions and concordance in a third sample) and only four (7%) demonstrated consistently discordant levels.<sup>193</sup> Thus, these two markers cannot be used interchangeably, and neither can currently be recommended for monitoring children with acute severe asthma.<sup>194</sup>

### MONITORING SIDE-EFFECTS

In addition to standard monitoring for both asthma and systemic steroid therapy, the question of adrenal insufficiency must be considered. Clearly, adrenal suppression is inevitable if

the child is on any but the lowest dose of oral steroids. Most recommend a synacthen test for children on high-dose ICSs, but the dose of adrenal corticotrophin, the sampling protocol and the frequency at which the test is performed are still controversial. Our current recommendation is for an annual standard synacthen test.

### ROLE OF AN ANNUAL ASSESSMENT?

There is a strong case to be made for a structured annual assessment in all children with severe, therapy-resistant asthma. This should include a re-evaluation of adherence (see above) and allergen exposure, as well as screening questionnaires at least for psychological morbidity. Spirometry and acute bronchodilator responsiveness, sputum induction and FeNO<sub>50</sub> should also be part of the evaluation. The annual assessment also provides the opportunity to evaluate side-effects with measurements of height and weight, blood pressure, urinalysis and the performance of a short synacthen test. Following this reassessment, a multidisciplinary planning meeting is held.

## Recent Advances in Pathophysiology

Very little is known about the pathophysiology of severe, therapy-resistant asthma in children. This section summarizes the findings of some recent studies. However, there is no definitive evidence in this field.

### GENETICS

Most genetic association studies have been in mild to moderate asthma, which is often very poorly phenotyped – ‘doctor diagnosed asthma’. Very few studies have performed the sort of detailed assessments described above.

Genetic and other studies suggest that PDCD4 is important in inflammatory responses in severe asthma, with multiple plausible mechanisms.<sup>195,196</sup>

### RESPONSE TO VIRAL INFECTIONS

We compared children with severe, therapy-resistant asthma with non-allergic healthy controls,<sup>197</sup> and showed that, as in adults,<sup>198–201</sup> an impaired innate antiviral response to rhinovirus is a feature of severe, therapy-resistant asthma.

### VITAMIN D

Vitamin D, once thought to be of importance just in bone health, is now known to have many immunomodulatory properties. Importantly, ‘normal’ ranges for serum vitamin D levels are based on bone health; the optimal values for immunological function are unknown and may not be the same.

We showed a stepwise relationship between asthma and 25(OH)D(3) levels: lowest in severe, therapy-resistant asthma and intermediate in mild/moderate asthma.<sup>202</sup> There was a positive relationship between 25(OH)D(3) levels and percentage predicted FEV<sub>1</sub>. 25(OH)D(3) levels were positively associated with ACT and inversely associated with exacerbations and ICS dose. Airway smooth muscle mass, but not epithelial shedding or reticular basement membrane thickness, was inversely related to 25(OH)D(3) levels and there was the expected positive correlation between smooth muscle mass and bronchodilator

reversibility. However, the real pathophysiological significance of vitamin D deficiency remains in doubt for two reasons. First, cross-sectional studies cannot disentangle cause from effect and it is entirely possible that low vitamin D results from immobility and lack of sunlight exposure due to severe asthma. Second, treatment effects are confounding as, for obvious reasons, studies have not included untreated patients with severe, therapy-resistant asthma. However, it would seem reasonable to give vitamin D supplements to children with severe, therapy-resistant asthma who have suboptimal serum levels.

### LESSONS FROM PEDIATRIC SARP

The key findings of the pediatric studies within this large study are:

- Cluster analysis identified four asthma clusters, with severe asthma being present in all four. The clusters were (1) relatively normal lung function and less atopic; (2) slightly worse lung function, more atopic and increased symptoms and medication use; (3) more co-morbidity, increased bronchial responsiveness and lower lung function; and (4) lowest lung function and greatest symptoms and medication use.<sup>203</sup> Worryingly, children with severe asthma had progressive airflow obstruction, but it was unclear whether this was the result of progression of remodeling or impaired lung growth.<sup>204</sup>
- Breath condensate pH was the same in children with severe and milder asthma,<sup>205</sup> but breath condensate formate concentration was significantly higher in those with severe asthma, possibly related to increased catabolism of endogenous S-nitrosothiols.<sup>206</sup>
- Children with severe asthma may have dysregulated macrophage function, manifest by decreased phagocytic function and increased apoptosis.<sup>207</sup> Dysregulated glutathione metabolism was associated with increased oxidative stress<sup>208</sup> and impacted alveolar macrophage function in severe compared to milder asthma.<sup>209</sup>

## Severe, Therapy-Resistant Asthma: The Future?

Prevention is always better than treatment. We need to be smarter at understanding and preventing nonadherence, and also detecting it. Internet technology is the key way forward with alerts to remind patients to take therapy, and using devices that detect correct activation and not just whether the device has been activated. Perhaps adherence issues with teenagers would disappear if their smartphones were automatically inactivated whenever they did not take their medications!

The planning of treatment for severe, therapy-resistant asthma will improve. The term ‘severe asthma’ will become as obsolete as the unqualified terms ‘severe anemia’ or ‘severe arthritis’. Crude planning on the basis of a single cell type measured on a single occasion will surely be replaced by sophisticated analyses of gene up- and down-regulation, using induced sputum or upper airway cells,<sup>210</sup> or exhaled breath analysis with devices such as the electronic nose.<sup>211</sup> We will follow the example of oncologists, who are now looking for tumor gene expression signatures and matching these to medications which reverse these changes. This approach has identified sodium valproate as a possible treatment for triple negative breast cancer,<sup>212</sup> not

an immediately obvious compound in this context. Of course, this innovative approach risks reversing what is a protective change, but must surely replace putting steroids in the tap water to control asthma.

Will pharmacogenomics deliver personalized therapy? It is likely that something more sophisticated than just looking at DNA will be needed. The complexities of gene-environment interactions have shown that the effect of CD14 polymorphisms is dependent on whether environmental lipopolysaccharide levels are high or low.<sup>213</sup> It seems likely that these gene-environment interactions, probably also involving epigenetic influences, may also influence individual medication responses.

So, promising improvements can be expected in the near future for those with very severe asthma, with the ability to identify those who respond to properly administered treatment, and a truly personalized program of therapy for those with severe, therapy-resistant asthma.

## Summary and Conclusions

Severe asthma is one of the great challenges of pediatric pulmonology. Mismanagement may result in a dead child. This

chapter has proposed a systematic approach to treatment. It is essential to optimize basic management, and this is not achievable without a skilled multidisciplinary team. We still do not really understand the underlying pathophysiology of very severe asthma and hence have no targeted treatments. It is not safe to assume that adult and pediatric severe asthma is the same disease; compared with adults, in children with severe asthma, atopy is much more prominent, there is no gender difference or increased prevalence of obesity, and eosinophilic not neutrophilic airway inflammation is the rule. Furthermore, eosinophilic asthma is in the main not Th2 driven, meaning that the successful use of anti-Th2 strategies in adults may not be replicated in children. There is a great need for mechanistic studies and randomized controlled trials of treatment in well-characterized groups of children with severe asthma, but these will only be possible once there is multinational and multicenter cooperation in adopting standardized assessment protocols.

The complete reference list can be found on the companion Expert Consult website at <http://www.expertconsult.inkling.com>.

## KEY REFERENCES

3. Chung KF, Wenzel SE, Brozek JL, Bush A, Castro M, Sterk PJ, et al. International ERS/ATS guidelines on definition, evaluation and treatment of severe asthma. *Eur Respir J* 2014; 43:343–73.
6. Bush A, Saglani S. Management of severe asthma in children. *Lancet* 2010;376:814–25.
16. de Groot EP, Duiverman EJ, Brand PL. Comorbidities of asthma during childhood: possibly important, yet poorly studied. *Eur Respir J* 2010;36:671–8.
36. de Groot EP, Duiverman EJ, Brand PL. Dysfunctional breathing in children with asthma: a rare but relevant comorbidity. *Eur Respir J* 2013;41:1068–73.
40. Bracken M, Fleming L, Hall P, Van Stiphout N, Bossley C, Biggart E, et al. The importance of nurse-led home visits in the assessment of children with problematic asthma. *Arch Dis Child* 2009;94:780–4.
106. Bossley C, Fleming L, Gupta A, Regamey N, Frith J, Oates T, et al. Pediatric severe asthma is characterized by eosinophilia and remodeling without TH2 cytokines. *J Allergy Clin Immunol* 2012;129:974–82.
108. Fitzpatrick AM, Higgins M, Holguin F, Brown LA, Teague WG, National Institutes of Health/National Heart, Lung, and Blood Institute's Severe Asthma Research Program. The molecular phenotype of severe asthma in children. *J Allergy Clin Immunol* 2010;125:851–7.
125. Bush A, Pedersen S, Hedlin G, Baraldi E, Barbato A, de Benedictis F, et al. Pharmacological treatment of severe, therapy-resistant asthma in children: what can we learn from where? *Eur Respir J* 2011;38:947–58.
191. Fleming L, Wilson N, Regamey N, Bush A. Use of sputum eosinophil counts to guide management in children with severe asthma. *Thorax* 2012;67:193–8.
192. Fleming L, Tsartsali L, Wilson N, Regamey N, Bush A. Sputum inflammatory phenotypes are not stable in children with asthma. *Thorax* 2012;67:675–81.



## REFERENCES

- Lang A, Carlsen KH, Haaland G, Devulapalli CS, Munthe-Kaas M, Mowinckel P, et al. Severe asthma in childhood: assessed in 10 year olds in a birth cohort study. *Allergy* 2008;63:1054–60.
- Reddy MB, Doshi J, Covar R, Spahn JD. The changing face of severe childhood asthma: a comparison of two cohorts of children evaluated at National Jewish Health over the past 20 years. *Allergy Asthma Proc* 2014;35:119–25.
- Chung KF, Wenzel SE, Brozek JL, Bush A, Castro M, Sterk PJ, et al. International ERS/ATS guidelines on definition, evaluation and treatment of severe asthma. *Eur Respir J* 2014;43:343–73.
- Lemanske RF Jr, Mauger DT, Sorkness CA, Jackson DJ, Boehmer SJ, Martinez FD, et al. Childhood Asthma Research and Education (CARE) Network of the National Heart, Lung, and Blood Institute. Step-up therapy for children with uncontrolled asthma receiving inhaled corticosteroids. *N Engl J Med* 2010;362:975–85.
- Bush A, Hedlin G, Calsen K-H, de Benedictis F, Lodrup-Carlsen K, Wilson N. Severe childhood asthma: a common international approach? *Lancet* 2008;372:1019–21.
- Bush A, Saglani S. Management of severe asthma in children. *Lancet* 2010;376:814–25.
- Hedlin G, Bush A, Lodrup Carlsen K, Wennergren G, De Benedictis FM, Melén E, et al., on behalf of the Problematic Severe Asthma in Childhood Initiative group. Problematic severe asthma in children, not one problem but many: a GA2LEN. Initiative. *Eur Respir J* 2010;36:196–201.
- Lodrup Carlsen KC, Hedlin G, Bush A, Wennergren G, de Benedictis FM, De Jongste JC, et al., on behalf of the PSACI (Problematic Severe Asthma in Childhood Initiative) group. Assessment of problematic severe asthma in children. *Eur Respir J* 2011;37:432–40.
- Cane RS, Raganathan SC, McKenzie SA. What do parents of wheezy children understand by “wheeze”? *Arch Dis Child* 2000;82:327–32.
- Cane RS, McKenzie SA. Parents’ interpretation of children’s respiratory symptoms on video. *Arch Dis Child* 2001;84:1–34.
- Elphick HE, Sherlock P, Foxall G, Simpson EJ, Shiell NA, Primhak RA, et al. Survey of respiratory sounds in infants. *Arch Dis Child* 2001;84:35–9.
- Saglani S, McKenzie SA, Bush A, Payne DN. A video questionnaire identifies upper airway abnormalities in pre-school children with reported wheeze. *Arch Dis Child* 2005;90:961–4.
- Levy ML, Godfrey S, Irving CS, Sheikh A, Hanekom W, Bush A, et al. Ambulatory Care Nurses. Wheeze detection in infants and pre-school children: recordings versus assessment of physician and parent. *J Asthma* 2004;41:845–53.
- Brand PL, Caudri D, Eber E, Gaillard EA, Garcia-Marcos L, Hedlin G, et al. Classification and pharmacological treatment of preschool wheezing: changes since 2008. *Eur Respir J* 2014;43:1172–7.
- Kelly YJ, Brabin BJ, Milligan PJ, Reid JA, Heaf D, Pearson MG. Clinical significance of cough and wheeze in the diagnosis of asthma. *Arch Dis Child* 1996;75:489–93.
- de Groot EP, Duiverman EJ, Brand PL. Comorbidities of asthma during childhood: possibly important, yet poorly studied. *Eur Respir J* 2010;36:671–8.
- Wilson NM, Charette L, Thomson AH, Silverman M. Gastro-oesophageal reflux and childhood asthma: the acid test. *Thorax* 1985;40:592–7.
- Wilson NM, Chudry N, Silverman M. Role of the oesophagus in asthma induced by the ingestion of ice and acid. *Thorax* 1987;42:506–10.
- Wilson N, Silverman M. Intraesophageal perfusion of acid increases the bronchomotor response to methacholine and isocapnic hyperventilation in asthmatic subjects. *Am Rev Respir Dis* 1987;136:525.
- Havemann BD, Hendersson CA, El-Serag HB. The association between gastro-oesophageal reflux disease and asthma: a systematic review. *Gut* 2007;56:1654–64.
- Thakkar K, Boatright RO, Gilger MA, El-Serag HB. Gastroesophageal reflux and asthma in children: a systematic review. *Pediatrics* 2010;125:e925–30.
- Writing Committee for the American Lung Association Asthma Clinical Research Centers, Holbrook JT, Wise RA, Gold BD, Blake K, Brown ED, et al. Lansoprazole for children with poorly controlled asthma: a randomized controlled trial. *JAMA* 2012;307:373–81.
- Sundberg R, Torén K, Höglund D, Aberg N, Brisman J. Nasal symptoms are associated with school performance in adolescents. *J Adolesc Health* 2007;40:581–3.
- Bousquet J, Bachert C, Canonica GW, Casale TB, Cruz AA, Lockey RJ, et al. Extended Global Allergy and Asthma European Network, World Allergy Organization and Allergic Rhinitis and its Impact on Asthma Study Group. Unmet needs in severe chronic upper airway disease (SCUAD). *J Allergy Clin Immunol* 2009;124:428–33.
- Rollin M, Seymour K, Hariri M, Harcourt J. Rhinosinusitis, symptomatology & absence of polyposis in children with primary ciliary dyskinesia. *Rhinology* 2009;47:75–8.
- de Groot EP, Nijkamp A, Duiverman EJ, Brand PL. Allergic rhinitis is associated with poor asthma control in children with asthma. *Thorax* 2012;67:582–7.
- de Benedictis FM, Bush A. Rhinosinusitis and asthma: epiphenomenon or causal association? *Chest* 1999;115:550–6.
- Haldar P, Pavord ID, Shaw DE, Berry MA, Thomas M, Brightling CE, et al. Cluster analysis and clinical asthma phenotypes. *Am J Respir Crit Care Med* 2008;178:218–24.
- Desai D, Newby C, Symon FA, Haldar P, Shah S, Gupta S, et al. Elevated sputum interleukin-5 and submucosal eosinophilia in obese individuals with severe asthma. *Am J Respir Crit Care Med* 2013;188:657–63.
- Sutherland ER, Goleva E, Strand M, Beuther DA, Leung DY. Body mass and glucocorticoid response in asthma. *Am J Respir Crit Care Med* 2008;178:682–7.
- Kim SH, Sutherland ER, Gelfand EW. Is there a link between obesity and asthma? *Allergy Asthma Immunol Res*. 2014;6:189–95.
- Xie X, Pan L, Ren D, Du C, Guo Y. Effects of continuous positive airway pressure therapy on systemic inflammation in obstructive sleep apnea: a meta-analysis. *Sleep Med* 2013;14:1139–50.
- Puthalapattu S, Ioachimescu OC. Asthma and obstructive sleep apnea: clinical and pathogenic interactions. *J Investig Med* 2014;62:665–75.
- Li AM, Hung E, Tsang T, Yin J, So HK, Wong E, et al. Induced sputum inflammatory measures correlate with disease severity in children with obstructive sleep apnoea. *Thorax* 2007;62:75–9.
- Barker NJ, Jones M, O’Connell NE, Everard ML. Breathing exercises for dysfunctional breathing/hyperventilation syndrome in children. *Cochrane Database Syst Rev* 2013;12:CD010376.
- de Groot EP, Duiverman EJ, Brand PL. Dysfunctional breathing in children with asthma: a rare but relevant comorbidity. *Eur Respir J* 2013;41:1068–73.
- Abu-Hassan M, Tannous B, Weinberger M. Exercise induced dyspnea in children and adolescents: if not asthma then what? *Ann Allergy Asthma Immunol* 2005;94:366–71.
- Seear M, Wensley D, West N. How accurate is the diagnosis of exercise-induced asthma among Vancouver schoolchildren? *Arch Dis Child* 2005;90:898–902.
- Van Dixhoorn DJ, Duivendorm HJ. Efficacy of Nijmegen Questionnaire in recognition of the hyperventilation syndrome. *J Psychosom Res* 1985;29:199–206.
- Bracken M, Fleming L, Hall P, Van Stiphout N, Bossley C, Biggart E, et al. The importance of nurse-led home visits in the assessment of children with problematic asthma. *Arch Dis Child* 2009;94:780–4.
- Bijl-Hofland ID, Cloosterman SG, Folgering HT, Akkermans RP, van Schayck CP. Relation of the perception of airway obstruction to the severity of asthma. *Thorax* 1999;54:15–19.
- Roberts G, Patel N, Levi-Schaffer F, Habibi P, Lack G. Food allergy as a risk factor for life-threatening asthma in childhood: a case-controlled study. *J Allergy Clin Immunol* 2003;112:168–74.
- Simpson AB, Glutting J, Yousef E. Food allergy and asthma morbidity in children. *Pediatr Pulmonol* 2007;42:489–95.
- O’Driscoll BR, Powell G, Chew F, Niven RM, Miles JF, Vyas A, et al. Comparison of skin prick tests with specific immunoglobulin E in the diagnosis of fungal sensitization in patients with severe asthma. *Clin Exp Allergy* 2009;39:1677–83.
- Frith J, Fleming L, Bossley C, Ullmann N, Bush A. The complexities of defining atopy in severe childhood asthma. *Clin Exp Allergy* 2011;41:948–53.
- Paraskakis E, Brindicci C, Fleming L, Krol R, Kharitonov SA, Wilson NM, et al. Measurement of bronchial and alveolar nitric oxide production in normal children and children with asthma. *Am J Respir Crit Care Med* 2006;174:260–7.
- Bacharier LB, Strunk RC, Mauger D, White D, Lemanske RF Jr, Sorkness CA. Classifying asthma severity in children: mismatch between symptoms, medication use, and lung function. *Am J Respir Crit Care Med* 2004;170:426–32.
- Expert Panel Report 3 (EPR-3): guidelines for the diagnosis and management of asthma—summary report 2007. *J Allergy Clin Immunol* 2007;120(Suppl.):S94–138.

49. van Dalen C, Harding E, Parkin J, Cheng S, Pearce N, Douwes J. Suitability of forced expiratory volume in 1 second/forced vital capacity vs percentage of predicted forced expiratory volume in 1 second for the classification of asthma severity in adolescents. *Arch Pediatr Adolesc Med* 2008;162:1169–74.
50. Morgan WJ, Stern DA, Sherrill DL, Guerra S, Holberg CJ, Guilbert TW, et al. Outcome of asthma and wheezing in the first 6 years of life: follow-up through adolescence. *Am J Respir Crit Care Med* 2005;172:1253–8.
51. Stern DA, Morgan WJ, Wright AL, Guerra S, Martinez FD. Poor airway function in early infancy and lung function by age 22 years: a non-selective longitudinal cohort study. *Lancet* 2007;370:758–64.
52. Sears MR, Greene JM, Willan AR, Wiecek EM, Taylor DR, Flannery EM, et al. A longitudinal, population-based, cohort study of childhood asthma followed to adulthood. *N Engl J Med* 2003;349:1414–22.
53. Oswald H, Phelan PD, Lanigan A, Hibbert M, Carlin JB, Bowes G, et al. Childhood asthma and lung function in mid-adult life. *Pediatr Pulmonol* 1997;23:14–20.
54. Tai A, Tran H, Roberts M, Clark N, Gibson AM, Vidmar S, et al. Outcomes of childhood asthma to the age of 50 years. *J Allergy Clin Immunol* 2014;133:1572–8.e3.
55. Strunk RC, Weiss ST, Yates KP, Tonascia J, Zeiger RS, Szefer SJ, et al. Mild to moderate asthma affects lung growth in children and adolescents. *J Allergy Clin Immunol* 2006;118:1040–7.
56. Belgrave DC, Buchan I, Bishop C, Lowe L, Simpson A, Custovic A. Trajectories of lung function during childhood. *Am J Respir Crit Care Med* 2014;189:1101–9.
57. Lodge CJ, Lowe AJ, Allen KJ, Zaloumis S, Gurrin LC, Matheson MC, et al. Childhood wheeze phenotypes show less than expected growth in FEV<sub>1</sub> across adolescence. *Am J Respir Crit Care Med* 2014;189:1351–8.
58. O'Byrne PM, Pedersen S, Lamm CJ, Tan WC, Busse WW, START Investigators Group. Severe exacerbations and decline in lung function in asthma. *Am J Respir Crit Care Med* 2009;179:19–24.
59. FitzGerald JM. Targeting lung attacks. *Thorax* 2011;66:365–6.
60. Sanders DB, Bittner RC, Rosenfeld M, Hoffman LR, Redding GJ, Goss CH. Failure to recover to baseline pulmonary function after cystic fibrosis pulmonary exacerbation. *Am J Respir Crit Care Med* 2010;182:627–32.
61. Sanders DB, Hoffman LR, Emerson J, Gibson RL, Rosenfeld M, Redding GJ, et al. Return of FEV<sub>1</sub> after pulmonary exacerbation in children with cystic fibrosis. *Pediatr Pulmonol* 2010;45:127–34.
62. Sanders DB, Bittner RC, Rosenfeld M, Redding GJ, Goss CH. Pulmonary exacerbations are associated with subsequent FEV<sub>1</sub> decline in both adults and children with cystic fibrosis. *Pediatr Pulmonol* 2011;46:393–400.
63. Bai TR, Vonk JM, Postma DS, Boezen HM. Severe exacerbations predict excess lung function decline in asthma. *Eur Respir J* 2007;30:52–6.
64. Zacharasiewicz A, Wilson N, Lex C, Erin EM, Li AM, Hansel T, et al. Clinical use of non-invasive measurements of airway inflammation in steroid reduction in children. *Am J Respir Crit Care Med* 2005;177:1077–82.
65. Awadh N, Muller NL, Park CS, Abboud RT, FitzGerald JM. Airway wall thickness in patients with near fatal asthma and control groups: assessment with high resolution computed tomographic scanning. *Thorax* 1998;53:248–53.
66. Paganin F, Seneterre E, Chanez P, Daurés JP, Bruel JM, Michel FB, et al. Computed tomography of the lungs in severe asthma: influence of disease severity and etiology. *Am J Respir Crit Care Med* 1996;153:110–14.
67. Jensen SP, Lynch DA, Brown KK, Wenzel SE, Newell JD. High-resolution CT features of severe asthma and bronchiolitis obliterans. *Clin Radiol* 2002;57:1078–85.
68. Kasahara K, Shiba K, Ozawa T, Okuda K, Adachi M. Correlation between the bronchial subepithelial layer and whole airway wall thickness in patients with asthma. *Thorax* 2002;57:242–6.
69. Gupta S, Siddiqui S, Haldar P, Raj JV, Entwisle JJ, Wardlaw AJ, et al. Qualitative analysis of high-resolution CT scans in severe asthma. *Chest* 2009;136:1521–8.
70. Marchac V, Emond S, Mamou-Mani T, Le Bihan-Benjamin C, Le Bourgeois M, De Blic J, et al. Thoracic CT in pediatric patients with difficult-to-treat asthma. *Am J Roentgenol* 2002;179:1245–52.
71. Saglani S, Papaioannou G, Khoo L, Ujita M, Jeffery PK, Owens C, et al. Can HRCT be used as a marker of airway remodeling in children with difficult asthma? *Respir Res* 2006;7:46.
72. de Blic J, Tillie-Leblond I, Emond S, Mahut B, Dang Duy TL, Scheinmann P. High-resolution computed tomography scan and airway remodeling in children with severe asthma. *J Allergy Clin Immunol* 2005;116:750–4.
73. de Blic J, Scheinmann P. The use of imaging techniques for assessing severe childhood asthma. *J Allergy Clin Immunol* 2007;119:808–10.
74. Pifferi M, Caransella D, Ragazzo V, Pietrobelli A, Boner AL. Low-density areas on high-resolution computed tomograms in chronic pediatric asthma. *J Pediatr* 2002;141:104–8.
75. Tillie-Leblond I, de Blic J, Jaubert F, Wallaert B, Scheinmann P, Gosset P. Airway remodeling is correlated with obstruction in children with severe asthma. *Allergy* 2008;63:533–41.
76. Jain N, Covar RA, Gleason MC, Newell JD Jr, Gelfand EW, Spahn JD. Quantitative computed tomography detects peripheral airway disease in children. *Pediatr Pulmonol* 2005;40:211–18.
- 76a. Gustafsson PM. Peripheral airway involvement in CF and asthma compared by inert gas washout. *Pediatr Pulmonol* 2007;42:168–76.
77. Gustafsson PM, De Jong PA, Tiddens HA, Lindblad A. Multiple-breath inert gas washout and spirometry versus structural lung disease in cystic fibrosis. *Thorax* 2008;63:129–34.
78. Owens CM, Aurora P, Stanojevic S, Bush A, Wade A, Oliver C, et al. Lung clearance index and HRCT are complementary markers of lung abnormalities in young children with CF. *Thorax* 2011;66:481–8.
79. Spitzer WO, Suissa S, Ernst P, Horwitz RI, Habbick B, Cockcroft D, et al. The use of  $\beta$ -agonists and the risk of death and near death from asthma. *N Engl J Med* 1992;326:501–6.
80. Orrell-Valente JK, Jarlsberg LG, Hill LG, Cabana MD. At what age do children start taking asthma medicines on their own? *Pediatrics* 2008;122:e1186–92.
81. Kamps AW, van Ewijk B, Roorda RJ, Brand PL. Poor inhalation technique, even after inhalation instructions, in children with asthma. *Pediatr Pulmonol* 2000;29:39–42.
82. Everard ML. Role of inhaler competence and contrivance in “difficult asthma”. *Paediatr Respir Rev* 2003;4:135–42.
83. Chalmers GW, Macleod KJ, Little SA, Thomson LJ, McSharry CP, Thomson NC. Influence of cigarette smoking on inhaled corticosteroid treatment in mild asthma. *Thorax* 2002;57:226–30.
84. Chaudhuri R, Livingston E, McMahon AD, Thomson L, Borland W, Thomson NC. Cigarette smoking impairs the therapeutic response to oral corticosteroids in chronic asthma. *Am J Respir Crit Care Med* 2003;168:1308–11.
85. Tomlinson JE, McMahon AD, Chaudhuri R, Thompson JM, Wood SF, Thomson NC. Efficacy of low and high dose inhaled corticosteroid in smokers versus non-smokers with mild asthma. *Thorax* 2005;60:282–7.
86. Livingston E, Chaudhuri R, McMahon AD, Fraser I, McSharry CP, Thomson NC. Systemic sensitivity to corticosteroids in smokers with asthma. *Eur Respir J* 2007;29:64–71.
87. Ranganathan SC, Payne DN, Jaffe A, McKenzie SA. Difficult asthma: defining the problems. *Pediatr Pulmonol* 2001;31:114–20.
88. Teach SJ, Crain EF, Quint DM, Hylan ML, Joseph JG. Indoor environmental exposures among children with asthma seen in an urban emergency department. *Pediatrics* 2006;117:S152–8.
89. De Boeck K, Moens M, Van Der Aa N, Meersman A, Schuddinck L, Proesmans M. Difficult asthma: can symptoms be controlled in a structured environment? *Pediatr Pulmonol* 2009;44:743–8.
90. Adcock IM, Barnes PJ. Molecular mechanisms of corticosteroid resistance. *Chest* 2008;134:394–401.
91. Kobayashi Y, Bossley C, Gupta A, Akashi K, Tsartsali L, Mercado N, et al. Passive smoking impairs histone deacetylase-2 in children with severe asthma. *Chest* 2014;145:305–12.
92. Murray CS, Poletti G, Kebadze T, Morris J, Woodcock A, Johnston SL, et al. Study of modifiable risk factors for asthma exacerbations: virus infection and allergen exposure increase the risk of asthma hospital admissions in children. *Thorax* 2006;61:376–82.
93. Sandberg S, Paton JY, Ahola S, McCann DC, McGuinness D, Hillary CR, et al. The role of acute and chronic stress in asthma attacks in children. *Lancet* 2000;356:982–7.
94. Sandberg S, McCann DC, Ahola S, Oja H, Paton JY, McGuinness D. Positive experiences and the relationship between stress and asthma in children. *Acta Paediatr* 2002;91:152–8.
95. Sandberg S, Järvenpää S, Penttinen A, Paton JY, McCann DC. Asthma exacerbations in children immediately following stressful life events: a Cox's hierarchical regression. *Thorax* 2004;59:1046–51.
96. Liu LY, Coe CL, Swenson CA, Kelly EA, Kita H, Busse WW. School examinations enhance airway inflammation to antigen challenge. *Am J Respir Crit Care Med* 2002;165:1062–7.
97. Letitre SL, de Groot EP, Draaisma E, Brand PL. Anxiety, depression and self-esteem in children with well-controlled asthma: case-control study. *Arch Dis Child* 2014;99:744–8.
98. Evans R 3rd, Gergen PJ, Mitchell H, Kattan M, Kercsmar C, Crain E, et al. A randomized

- clinical trial to reduce asthma morbidity among inner-city children: results of the National Cooperative Inner-City Asthma Study. *J Pediatr* 1999;135:332–8.
99. Smith JR, Mugford M, Holland R, Candy B, Noble MJ, Harrison BD, et al. A systematic review to examine the impact of psycho-educational interventions on health outcomes and costs in adults and children with difficult asthma. *Health Technol Assess* 2005;9:1–167.
  100. Kotses H, Stout C, Wigal JK. Individualised asthma self-management: a beginning. *J Asthma* 1991;28:287–9.
  101. Kotses H, Stout C, McConaughy K, Winder JA, Creer TL. Evaluation of individualized asthma self-management programs. *J Asthma* 1996;33:113–18.
  102. Sharples J, Gupta A, Fleming L, Bossley CJ, Bracken-King M, Hall P, et al. Long-term effectiveness of a staged assessment for paediatric problematic severe asthma [Research Letter]. *Eur Respir J* 2012;40:264–7.
  103. Morgan WJ, Crain EF, Gruchalla RS, O'Connor GT, Kattan M, Evans R 3rd, et al. Results of a home-based environmental intervention among urban children with asthma. *N Engl J Med* 2004;351:1068–80.
  104. Wang J, Visness CM, Calatroni A, Gergen PJ, Mitchell HE, Sampson HA. Effect of environmental allergen sensitization on asthma morbidity in inner-city asthmatic children. *Clin Exp Allergy* 2009;39:1381–9.
  105. Fitzpatrick AM, Gaston BM, Erzurum SC, Teague WG, National Institutes of Health/National Heart, Lung, and Blood Institute Severe Asthma Research Program. Features of severe asthma in school-age children: Atopy and increased exhaled nitric oxide. *J Allergy Clin Immunol* 2006;118:1218–25.
  106. Bossley C, Fleming L, Gupta A, Regamey N, Friith J, Oates T, et al. Pediatric severe asthma is characterized by eosinophilia and remodeling without TH2 cytokines. *J Allergy Clin Immunol* 2012;129:974–82.
  107. Lex C, Ferreira F, Zacharasiewicz A, Nicholson AG, Haslam PL, Wilson NM, et al. Airway eosinophilia in children with severe asthma: predictive values of noninvasive tests. *Am J Respir Crit Care Med* 2006;174:1286–91.
  108. Fitzpatrick AM, Higgins M, Holguin F, Brown LA, Teague WG, National Institutes of Health/National Heart, Lung, and Blood Institute's Severe Asthma Research Program. The molecular phenotype of severe asthma in children. *J Allergy Clin Immunol* 2010;125:851–7.
  109. Woodruff PG, Modrek B, Choy DF, Jia G, Abbas AR, Ellwanger A, et al. T-helper type 2-driven inflammation defines major subphenotypes of asthma. *Am J Respir Crit Care Med* 2009;180:388–95.
  110. Saglani S. Innate helper cells: a novel cell type essential in the initiation of asthma? *Thorax* 2011;66:834–5.
  111. Saglani S, Lui S, Ullmann N, Campbell GA, Sherburn RT, Mathie SA, et al. IL-33 promotes airway remodeling in pediatric patients with severe, steroid-resistant asthma. *J Allergy Clin Immunol* 2013;132:676–85.
  112. Gauvreau GM, O'Byrne PM, Boulet LP, Wang Y, Cockcroft D, Bigler J, et al. Effects of an anti-TSLP antibody on allergen-induced asthmatic responses. *N Engl J Med* 2014;379:2102–10.
  113. Dahlen SE. TSLP in asthma—a new kid on the block? *N Engl J Med* 2014;370:2144–5.
  114. Barczyk A, Pierzchala W, Sozańska E. Interleukin-17 in sputum correlates with airway hyperresponsiveness to methacholine. *Respir Med* 2003;97:726–733.5.
  115. Kudo M, Melton AC, Chen C, Engler MB, Huang KE, Ren X, et al. IL-17A produced by  $\alpha\beta$  T cells drives airway hyper-responsiveness in mice and enhances mouse and human airway smooth muscle contraction. *Nat Med* 2012;18:547–54.
  116. Busse WW, Holgate S, Kerwin E, Chon Y, Feng J, Lin J, et al. Randomized, double-blind, placebo-controlled study of brodalumab, a human anti-IL-17 receptor monoclonal antibody, in moderate to severe asthma. *Am J Respir Crit Care Med* 2013;188:1294–302.
  117. Pavord ID, Korn S, Howarth P, Bleecker ER, Buhl R, Keene ON, et al. Mepolizumab for severe eosinophilic asthma (DREAM): a multicentre, double-blind, placebo-controlled trial. *Lancet* 2012;380:651–9.
  118. De Boever EH, Ashman C, Cahn AP, Locantore NW, Overend P, Pouliquen IJ, et al. Efficacy and safety of an anti-IL-13 mAb in patients with severe asthma: a randomized trial. *J Allergy Clin Immunol* 2014;133:989–96.
  119. Wenzel S, Ford L, Pearlman D, Spector S, Sher L, Skobieranda F, et al. Dupilumab in persistent asthma with elevated eosinophil levels. *N Engl J Med* 2013;368:2455–66.
  120. Adcock IM, Ito K. Steroid resistance in asthma: a major problem requiring novel solutions or a non-issue? *Curr Opin Pharmacol* 2004;4:257–62.
  121. Little SA, Chalmers GW, Macleod KJ, McSharry C, Thomson NC. Non-invasive markers of airway inflammation as predictors of oral steroid responsiveness in asthma. *Thorax* 2000;55:232–4.
  122. Bossley CJ, Saglani S, Kavanagh C, Payne DN, Wilson N, Tsartsali L, et al. Corticosteroid responsiveness and clinical characteristics in childhood difficult asthma. *Eur Respir J* 2009;34:1052–9.
  123. Lex C, Payne DN, Zacharasiewicz A, Li AM, Nicholson AG, Wilson NM, et al. Is a two-week trial of oral prednisolone predictive of target lung function in pediatric asthma? *Pediatr Pulmonol* 2005;39:521–7.
  124. Cartledge N, Brown S, Bossley C, Gupta A, Fleming L, Saglani S, et al. Is a single intramuscular dose of triamcinolone and acute bronchodilator sufficient to determine optimal lung function in children with severe, therapy-resistant asthma? *Thorax* 2011;66(Suppl. 4):A101–2.
  125. Bush A, Pedersen S, Hedlin G, Baraldi E, Barbato A, de Benedictis F, et al. Pharmacological treatment of severe, therapy-resistant asthma in children: what can we learn from where? *Eur Respir J* 2011;38:947–58.
  126. Milgrom H, Berger W, Nayak A, Gupta N, Pollard S, McAlary M, et al. Treatment of childhood asthma with anti-immunoglobulin E antibody (omalizumab). *Paediatrics* 2001;108:6–45.
  127. Lemanske R, Nayak A, McAlary M, Everhard F, Fowler-Taylor A, Gupta N. Omalizumab improves asthma-related quality of life in children with allergic asthma. *Paediatrics* 2002;110:e55–9.
  128. Berger W, Gupta N, McAlary M, Fowler-Taylor A. Evaluation of long term safety of the anti-IgE antibody, omalizumab, in children with allergic asthma. *Annals Allergy Asthma Immunol* 2003;91:182–8.
  129. Lanier B, Bridges T, Kulus M, Taylor AF, Berhane I, Vidaurre CF. Omalizumab for the treatment of exacerbations in children with inadequately controlled allergic (IgE-mediated) asthma. *J Allergy Clin Immunol* 2009;124:1210–16.
  130. Bousquet J, Cabrera P, Berkman N, Buhl R, Holgate S, Wenzel S, et al. The effect of treatment with omalizumab, an anti-IgE antibody, on asthma exacerbations and emergency medical visits in patients with severe persistent asthma. *Allergy* 2005;60:302–8.
  131. D'Amato G, Salzillo A, Piccolo A, D'Amato M, Liccardi G. A review of anti-IgE monoclonal antibody (omalizumab) as add on therapy for severe allergic (IgE-mediated) asthma. *Ther Clin Risk Manag* 2007;3:613–19.
  132. Rodrigo GJ, Neffen H, Castro-Rodriguez JA. Efficacy and safety of subcutaneous omalizumab vs placebo as add-on therapy to corticosteroids for children and adults with asthma: a systematic review. *Chest* 2011;139:28–35.
  133. Schumann C, Kropf C, Wibmer T, Rüdiger S, Stoiber KM, Thielen A, et al. Omalizumab in patients with severe asthma: the XCLUSIVE study. *Clin Respir J* 2012;6:215–27.
  134. Lafeuille MH, Dean J, Zhang J, Duh MS, Gorsh B, Lefebvre P. Impact of omalizumab on emergency-department visits, hospitalizations, and corticosteroid use among patients with uncontrolled asthma. *Ann Allergy Asthma Immunol* 2012;109:59–64.
  135. Brodli M, McKean MC, Moss S, Spencer DA. The oral corticosteroid-sparing effect of omalizumab in children with severe asthma. *Arch Dis Child* 2012;97:604–9.
  136. Garcia G, Magnan A, Chiron R, Contin-Bordes C, Berger P, Taillé C, et al. A proof-of-concept, randomized, controlled trial of omalizumab in patients with severe, difficult-to-control, non-atopic asthma. *Chest* 2013;144:411–19.
  137. Adams NP, Bestall JC, Jones P, Lasserson TJ, Griffiths B, Cates CJ. Fluticasone at different doses for chronic asthma in adults and children. *Cochrane Database Syst Rev* 2008;4:CD003534.
  138. Kraft M, Djukanovic R, Wilson S, Holgate ST, Martin RJ. Alveolar tissue inflammation in asthma. *Am J Respir Crit Care Med* 1996;154:1505–10.
  139. Sutherland ER, Martin RJ, Bowler RP, Zhang Y, Rex MD, Kraft M. Physiologic correlates of distal lung inflammation in asthma. *J Allergy Clin Immunol* 2004;113:1046–50.
  140. Kraft M, Martin RJ, Wilson S, Djukanovic R, Holgate ST. Lymphocyte and eosinophil influx into alveolar tissue in nocturnal asthma. *Am J Respir Crit Care Med* 1999;159:228–34.
  141. Cohen J, Douma WR, ten Hacken NH, Vonk JM, Oudkerk M, Postma DS. Ciclesonide improves measures of small airway involvement in asthma. *Eur Respir J* 2008;31:1213–20.
  142. Berry M, Hargadon B, Morgan A, Shelley M, Richter J, Shaw D, et al. Alveolar nitric oxide in adults with asthma: evidence of distal lung inflammation in refractory asthma. *Eur Respir J* 2005;25:986–91.
  143. Cates CJ, Lasserson TJ. Combination formoterol and budesonide as maintenance and reliever therapy versus inhaled steroid maintenance for chronic asthma in adults and children. *Cochrane Database Syst Rev* 2009;2:CD007313.



144. Bisgaard H, Le Roux P, Bjämer D, Dymek A, Vermeulen JH, Hultquist C. Budesonide/formoterol maintenance plus reliever therapy: a new strategy in paediatric asthma. *Chest* 2006;130:1733–43.
145. Chapman KR, Barnes NC, Greening AP, Jones PW, Pedersen S. Single maintenance and reliever therapy (SMART) of asthma: a critical appraisal. *Thorax* 2010;65:747–52.
146. Sullivan PJ, Bekir S, Jaffar Z, Page C, Jeffery P, Costello J. The effects of low-dose theophylline on the bronchial wall infiltrate after allergen challenge. *Lancet* 1993;343:1006–8.
147. Yasui K, Hu B, Nakazawa T, Agematsu K, Komiyama A. Theophylline accelerates human granulocyte apoptosis not *via* phosphodiesterase inhibition. *J Clin Invest* 1997;100:1677–84.
148. Yasui K, Agematsu K, Shinozaki K, Hokibara S, Nagumo H, Nakazawa T, et al. Theophylline induces neutrophil apoptosis through adenosine A2A receptor antagonism. *J Leukoc Biol* 2000;67:529–35.
149. Kidney J, Dominguez M, Taylor PM, Rose M, Chung KF, Barnes PJ. Immunomodulation by theophylline in asthma. Demonstration by withdrawal of therapy. *Am J Respir Crit Care Med* 1995;151:1907–14.
150. Cosío BG, Mann B, Ito K, Jazrawi E, Barnes PJ, Chung KF, et al. Histone acetylase and deacetylase activity in alveolar macrophages and blood monocytes in asthma. *Am J Respir Crit Care Med* 2004;170:141–7.
151. Derks MG, Koopmans RP, Oosterhoff E, Van Boxtel CJ. Prevention by theophylline of beta-2-receptor down regulation in healthy subjects. *Eur J Drug Metab Pharmacokin* 2000;25:179–88.
152. Seddon P, Bara A, Ducharme FM, Lasserson TJ. Oral xanthines as maintenance treatment for asthma in children. *Cochrane Database Syst Rev* 2006;1:CD002885.
153. American Lung Association Asthma Clinical Research Centers. Clinical trial of low-dose theophylline and montelukast in patients with poorly controlled asthma. *Am J Respir Crit Care Med* 2007;175:235–42.
154. Denning DW, O'Driscoll BR, Powell G, Chew F, Atherton GT, Vyas A, et al. Randomized controlled trial of oral antifungal sensitization. The fungal asthma sensitization trial (FAST) study. *Am J Respir Crit Care Med* 2009;179:11–18.
155. Agbetile J, Bourne M, Fairs A, Hargadon B, Desai D, Broad C, et al. Effectiveness of voriconazole in the treatment of *Aspergillus fumigatus*-associated asthma (EVITA3 study). *J Allergy Clin Immunol* 2014;134:33–9.
156. Vicencio AG, Santiago MT, Tsirilakis K, Stone A, Worgall S, Foley EA, et al. Fungal sensitization in childhood persistent asthma is associated with disease severity. *Pediatr Pulmonol* 2014;49:8–14.
157. Bolland MJ, Bagg W, Thomas MG, Lucas JA, Ticehurst R, Black PN. Cushing's syndrome due to interaction between inhaled corticosteroids and itraconazole. *Ann Pharmacother* 2004;38:46–9.
158. De Wachter E, Malfroot A, De Schutter I, Vanbesien J, De Schepper J. Inhaled budesonide induced Cushing's syndrome in cystic fibrosis patients, due to drug inhibition of cytochrome P450. *J Cyst Fibros* 2003;2:72–5.
159. Pilmis B, Coignard-Biehler H, Jullien V, Hermine O, Touraine P, Lecuit M, et al. Iatrogenic Cushing's syndrome induced by posaconazole. *Antimicrob Agents Chemother* 2013;57:5727–8.
160. Blondin MC, Beauregard H, Serri O. Iatrogenic Cushing syndrome in patients receiving inhaled budesonide and itraconazole or ritonavir: two cases and literature review. *Endocr Pract* 2013;19:e138–41.
161. Brusselle GG, Joos G. Is there a role for macrolides in severe asthma? *Curr Opin Pulm Med* 2014;20:95–102.
162. Reiter J, Demirel N, Mendy A, Gasana J, Vieira ER, Colin AA, et al. Macrolides for the long-term management of asthma—a meta-analysis of randomized clinical trials. *Allergy* 2013;68:1040–9.
163. Strunk RC, Bacharier LB, Phillips BR, Szefer SJ, Zeiger RS, Chinchilli VM, et al. Azithromycin or montelukast as inhaled corticosteroid-sparing agents in moderate to severe childhood asthma study. *J Allergy Clin Immunol* 2008;122:1138–44.
164. Jakobsson T, Croner S, Kjellman NI, Pettersson A, Vassella C, Björkstén B. Slight steroid-sparing effect of intravenous immunoglobulin in children and adolescents with moderately severe bronchial asthma. *Allergy* 1994;49:413–20.
165. Mazer BD, Gelfand EW. An open-label study of high-dose intravenous immunoglobulin in severe childhood asthma. *J Allergy Clin Immunol* 1991;87:976–83.
166. Niggemann B, Leupold W, Schuster A, Schuster R, v Berg A, Grübl A et al. Prospective, double-blind, placebo-controlled, multicentre study on the effect of high-dose, intravenous immunoglobulin in children and adolescents with severe bronchial asthma. *Clin Exp Allergy* 1998;28:205–10.
167. Vrugt B, Wilson S, van Velzen E, Bron A, Shute JK, Holgate ST, et al. Effects of high dose intravenous immunoglobulin in two severe corticosteroid insensitive asthmatic patients. *Thorax* 1997;52:662–4.
168. Spahn JD, Leung DY, Chan MT, Szefer SJ, Gelfand EW. Mechanisms of glucocorticoid reduction in asthmatic subjects treated with intravenous immunoglobulin. *J Allergy Clin Immunol* 1999;103:421–6.
169. Aaron SD, Dales RE, Pham B. Management of steroid-dependent asthma with methotrexate: a meta-analysis of randomized clinical trials. *Respir Med* 1998;92:1059–65.
170. Marin MG. Low-dose methotrexate spares steroid usage in steroid-dependent asthmatic patients: a meta-analysis. *Chest* 1997;112:29–33.
171. Coren ME, Rosenthal M, Bush A. The use of cyclosporin in corticosteroid dependent asthma. *Arch Dis Child* 1997;77:522–3.
172. Payne DNR, Balfour-Lynn IM, Biggart EA, Bush A, Rosenthal M. Subcutaneous terbutaline in children with chronic severe asthma. *Pediatr Pulmonol* 2002;33:356–61.
173. Reddel H, Ware S, Marks G, Salome C, Jenkins C, Woolcock A. Differences between asthma exacerbations and poor asthma control. *Lancet* 1999;353:364–9.
174. Sur S, Crotty TB, Kephart GM, Hyma BA, Colby TV, Reed CE, et al. Sudden-onset fatal asthma. A distinct entity with few eosinophils and relatively more neutrophils in the airway submucosa? *Am Rev Respir Dis* 1993;148:713–19.
175. Haselkorn T, Fish JE, Zeiger RS, Szefer SJ, Miller DP, Chipps BE, et al. Consistently very poorly controlled asthma, as defined by the impairment domain of the Expert Panel Report 3 guidelines, increases risk for future severe asthma exacerbations in The Epidemiology and Natural History of Asthma: Outcomes and Treatment Regimens (TENOR) study. *J Allergy Clin Immunol* 2009;124:895–902.
176. Haselkorn T, Zeiger RS, Chipps BE, Mink DR, Szefer SJ, R Simons FE, et al. Recent asthma exacerbations predict future exacerbations in children with severe or difficult-to-treat asthma. *J Allergy Clin Immunol* 2009;124:921–7.
177. Carroll NE, Carello S, Cooke C, James A. Airway structure and inflammatory cells in fatal attacks of asthma. *Eur Respir J* 1996;9:709–15.
178. Gibson PG, Norzila MZ, Fakes K, Simpson J, Henry RL. Pattern of airway inflammation and its determinants in children with acute severe asthma. *Pediatr Pulmonol* 1999;28:261–70.
179. Ballester F, Soriano JB, Otero I, Rivera ML, Sunyer J, Merelles A, et al. Asthma visits to emergency rooms and soybean unloading in the harbors of Valencia and A Coruña, Spain. *Am J Epidemiol* 1999;149:315–22.
180. Marks GB, Colquhoun JR, Girgis ST, Koski MH, Treloar AB, Hansen P, et al. Thunderstorm outflows preceding epidemics of asthma during spring and summer. *Thorax* 2001;56:468–71.
181. Wark PA, Simpson J, Hensley MJ, Gibson PG. Airway inflammation in thunderstorm asthma. *Clin Exp Allergy* 2002;32:1750–6.
182. Haldar P, Brightling CE, Hargadon B, Gupta S, Monteiro W, Sousa A, et al. Mepolizumab and exacerbations of refractory eosinophilic asthma. *N Engl J Med* 2009;360:973–84.
183. Nair P, Pizzichini MM, Kjarsgaard M, Inman MD, Efthimiadis A, Pizzichini E, et al. Mepolizumab for prednisone-dependent asthma with sputum eosinophilia. *N Engl J Med* 2009;360:985–93.
184. Pauwels RA, Löfdahl CG, Postma DS, Tattersfield AE, O'Byrne P, Barnes PJ, et al. Effect of inhaled formoterol and budesonide on exacerbations of asthma. Formoterol and Corticosteroids Establishing Therapy (FACET) International Study Group. *N Engl J Med* 1997;337:1405–11.
185. Cates CJ, Lasserson TJ. Combination formoterol and budesonide as maintenance and reliever therapy versus inhaled steroid maintenance for chronic asthma in adults and children. *Cochrane Database Syst Rev* 2009;2:CD007313.
186. Cates CJ, Lasserson TJ. Combination formoterol and inhaled steroid versus beta2-agonist as relief medication for chronic asthma in adults and children. *Cochrane Database Syst Rev* 2009;2:CD007085.
187. McKean M, Ducharme F. Inhaled steroids for episodic viral wheeze of childhood. *Cochrane Database Syst Rev* 2000;2:CD001107.
188. Robertson CE, Price D, Henry R, Mellis C, Glasgow N, Fitzgerald D, et al. Short-course montelukast for intermittent asthma in children: a randomized controlled trial. *Am J Respir Crit Care Med* 2007;175:323–9.
189. Green RH, Brightling CE, McKenna S, Hargadon B, Parker D, Bradding P, et al. Asthma exacerbations and sputum eosinophil counts: a randomised controlled trial. *Lancet* 2002;360:1715–21.



190. Jayaram L, Pizzichini MM, Cook RJ, Boulet LP, Lemièrre C, Pizzichini E, et al. Determining asthma treatment by monitoring sputum cell counts: effect on exacerbations. *Eur Respir J* 2006;27:483–94.
191. Fleming L, Wilson N, Regamey N, Bush A. Use of sputum eosinophil counts to guide management in children with severe asthma. *Thorax* 2012;67:193–8.
192. Fleming L, Tsartsali L, Wilson N, Regamey N, Bush A. Sputum inflammatory phenotypes are not stable in children with asthma. *Thorax* 2012;67:675–81.
193. Fleming L, Tsartsali L, Wilson N, Regamey N, Bush A. Longitudinal relationship between sputum eosinophils and exhaled nitric oxide in children with asthma. *Am J Respir Crit Care Med* 2013;188:400–2.
194. Petsky HL, Cates CJ, Lasserson TJ, Li AM, Turner C, Kynaston JA, et al. A systematic review and meta-analysis: tailoring asthma treatment on eosinophilic markers (exhaled nitric oxide or sputum eosinophils). *Thorax* 2012;67:199–208.
195. Wan YI, Shrine NR, Soler Artigas M, Wain LV, Blakey JD, Moffatt MF, et al. Genome-wide association study to identify genetic determinants of severe asthma. *Thorax* 2012;67:762–8.
196. Binia A, Van Stiphout N, Liang L, Michel S, Bhavsar PK, Fan Chung K, et al. A polymorphism affecting MYB binding within the promoter of the PDCD4 gene is associated with severe asthma in children. *Hum Mutat* 2013;34:1131–9.
197. Edwards MR, Regamey N, Vareille M, Kieninger E, Gupta A, Shoemark A, et al. Impaired innate interferon induction in severe therapy resistant atopic asthmatic children. *Mucosal Immunol* 2013;6:797–806.
198. Contoli M, Message SD, Laza-Stanca V, Edwards MR, Wark PA, Bartlett NW, et al. Role of deficient type III interferon-lambda production in asthma exacerbations. *Nat Med* 2006;12:1023–6.
199. Wark PA, Johnston SL, Bucchieri F, Powell R, Puddicombe S, Laza-Stanca V, et al. Asthmatic bronchial epithelial cells have a deficient innate immune response to infection with rhinovirus. *J Exp Med* 2005;201:937–47.
200. Sykes A, Edwards MR, Macintyre J, del Rosario A, Bakhsholiani E, Trujillo-Torralbo MB, et al. Rhinovirus 16-induced IFN- $\alpha$  and IFN- $\beta$  are deficient in bronchoalveolar lavage cells in asthmatic patients. *J Allergy Clin Immunol* 2012;129:1506–14.
201. Iikura K, Katsunuma T, Saika S, Ichinohe S, Ida H, Saito H, et al. Peripheral blood mononuclear cells from patients with bronchial asthma show impaired innate immune responses to rhinovirus in vitro. *Int Arch Allergy Immunol* 2011;155(Suppl. 1):27–33.
202. Gupta A, Sjoukes A, Richards D, Banya W, Hawrytowicz C, Bush A, et al. Relationship between serum vitamin D, disease severity and airway remodeling in children with asthma. *Am J Respir Crit Care Med* 2011;184:1342–9.
203. Fitzpatrick AM, Teague WG, Meyers DA, Peters SP, Li X, Li H, et al., National Institutes of Health/National Heart, Lung, and Blood Institute Severe Asthma Research Program. Heterogeneity of severe asthma in childhood: confirmation by cluster analysis of children in the National Institutes of Health/National Heart, Lung, and Blood Institute Severe Asthma Research Program. *J Allergy Clin Immunol* 2011;127:382–9.
204. Fitzpatrick AM, Teague WG, National Institutes of Health/National Heart, Lung, and Blood Institute's Severe Asthma Research Program. Progressive airflow limitation is a feature of children with severe asthma. *J Allergy Clin Immunol* 2011;127:282–4.
205. Liu L, Teague WG, Erzurum S, Fitzpatrick A, Mantri S, Dweik RA, et al., National Heart, Lung, and Blood Institute Severe Asthma Research Program (SARP). Determinants of exhaled breath condensate pH in a large population with asthma. *Chest* 2011;139:328–36.
206. Greenwald R, Fitzpatrick AM, Gaston B, Marozkina NV, Erzurum S, Teague WG. Breath formate is a marker of airway S-nitrosothiol depletion in severe asthma. *PLoS ONE* 2010;5:e11919.
207. Fitzpatrick AM, Holguin F, Teague WG, Brown LA. Alveolar macrophage phagocytosis is impaired in children with poorly controlled asthma. *J Allergy Clin Immunol* 2008;121:1372–8.
208. Fitzpatrick AM, Teague WG, Holguin F, Yeh M, Brown LA. Severe Asthma Research Program. Airway glutathione homeostasis is altered in children with severe asthma: evidence for oxidant stress. *J Allergy Clin Immunol* 2009;123:146–52.
209. Fitzpatrick AM, Teague WG, Burwell L, Brown MS, Brown LA. NIH/NHLBI Severe Asthma Research Program. Glutathione oxidation is associated with airway macrophage functional impairment in children with severe asthma. *Pediatr Res* 2011;69:154–9.
210. Zhang X, Sebastiani P, Liu G, Schembri F, Zhang X, Dumas YM, et al. Similarities and differences between smoking-related gene expression in nasal and bronchial epithelium. *Physiol Genomics* 2010;41:1–8.
211. Fens N, van der Schee MP, Brinkman P, Sterk PJ. Exhaled breath analysis by electronic nose in airways disease. Established issues and key questions. *Clin Exp Allergy* 2013;43:705–15.
212. Cohen AL, Soldi R, Zhang H, Gustafson AM, Wilcox R, Welm BE, et al. A pharmacogenomic method for individualized prediction of drug sensitivity. *Mol Syst Biol* 2011;7:513.
213. Simpson A, John SL, Jury F, Niven R, Woodcock A, Ollier WE, et al. Endotoxin exposure, CD14, and allergic disease: an interaction between genes and the environment. *Am J Respir Crit Care Med* 2006;174:386–92.

# Promoting Adherence and Effective Self-Management in Patients with Asthma

BRUCE G. BENDER

## KEY POINTS

- Patients often take less than half of their prescribed controller medication, and surprisingly many stop taking their controller medication altogether after an initial filling at their pharmacy.
- Decreasing adherence contributes to poor control and increased exacerbation risk, in turn driving up health-care costs.
- Complex and time-consuming adherence interventions are difficult to integrate into everyday clinical practice.
- Evidence-based, time-efficient strategies can be adopted by most providers to increase patient adherence.
- Successful strategies utilize principles of patient-centered care and effective communication, including collaboration on treatment goals and plans.

## Nonadherence Undermines Treatment

Patient adherence with asthma self-management plans, as with all chronic medical conditions, is often poor. Adherence to daily medication regimens averages about 50% or less for chronic conditions in general,<sup>1</sup> including patients with asthma.<sup>2,3</sup> *Adherence* as defined in these studies means that about half of the prescribed medication was taken, although it does not necessarily signify that it was taken in the appropriate manner. In addition, the report of 50% medication adherence reflects the average of groups of patients studied but does not translate into a uniform pattern of taking every other dose of medication. Individual adherence patterns include widely varying behaviors, with some patients taking close to all their medications at the appropriate time and others taking almost no medication.<sup>3</sup> Individual adherence fluctuates greatly over time, often with periods of time during which patients take no medication for varying periods, often for days or weeks at a time.<sup>4</sup> Further, asthma medication adherence may be on the decline. A 1993 review of ten published studies found that adherence had averaged 48%.<sup>5</sup> Recently published studies have reported mean inhaled corticosteroids (ICS) adherence at 34% in adults<sup>6</sup> and 40% in children.<sup>7</sup> Other studies have shown alarmingly high rates of medication abandonment, reflected in refill nonpersistence, a problem not unique to asthma. For example, large administrative and pharmacy database studies have revealed

that 59% of patients with asthma,<sup>8</sup> 39% of patients with hypertension<sup>9</sup> and 86% of patients with chronic obstructive pulmonary disease (COPD) ceased refilling their medication and did not return to fill again within a year.<sup>10</sup> Decreasing ICS adherence is followed by worsening asthma symptoms in children.<sup>11</sup> Because most adherence research is conducted on patients who volunteer to participate in studies and know that their adherence is being monitored, these numbers may be inflated. One medication refill study, reflecting the behavior of 5,500 adult and pediatric patients using a national pharmacy chain, found mean ICS adherence of 22.2% over 12 months.<sup>8</sup>

## Impact of Nonadherence

Depending on the duration of action and the drug side-effects profile, periods of nonadherence may have several potential consequences, including waning drug action, hazardous rebound effects when administration stops abruptly, and overdose effects when administration of full-strength drugs suddenly resumes.<sup>4</sup> In studies of metered-dose inhaler (MDI) use among children with asthma, inhalers were not used on 48% of study days and abandonment of medication typically occurred for several consecutive days.<sup>12</sup> The consequences of such start-and-stop adherence patterns are unknown. Time to onset of the effectiveness of ICS in the treatment of mild-to-moderate asthma is about 3 weeks, with faster impact (3 days) reflected on morning peak expiratory flow values in patients with severe asthma.<sup>13</sup> It remains to be determined how varying patterns of adherence translate into asthma control and whether, for example, control in patients with relatively high adherence who fail to use their medication for 1 week or longer is poorer than in patients who use less total medication but with better regularity.<sup>14</sup>

While the assumption that underuse of asthma controller medication can result in less control over the disorder is accurate, conclusions about the amount of medication required by any individual child are difficult to establish largely because of individual variations in disease characteristics, medication requirements and drug metabolism rates. The prevailing standard, as reflected by the US National Asthma Education and Prevention Program (NAEPP) guidelines for the diagnosis and management of asthma, is that increased medication administration is the correct response to inadequate symptom control.<sup>15</sup> The potential benefit of medication escalation on the part of the physician is realized only if the patient responds by adhering to the new regimen. Although some studies have defined nonadherence as less than 75% of medication taken, it is impossible to establish a minimum level of adherence that is sufficient for

all patients. Evidence exists that ICS are highly effective in controlling asthma, that some benefit persists even at relatively low dosing frequency, and that a dose-response relationship exists between degree of adherence and degree of benefit. Suissa et al,<sup>16</sup> for example, conducted a nested case-control study of patients with severe asthma and found that decreasing number of ICS pharmacy refills was associated with increasing risk of death from asthma. As few as three ICS canisters per year reduced risk by one half, with increasing protection gained as refills increased up to a full adherence level of 12 canisters per year. Clearly, as adherence levels drop, asthma becomes less controlled. For example, in a 3-month study, children with a median ICS adherence of 14% had asthma exacerbations requiring urgent office visits and oral steroid bursts, whereas those with adherence levels of 68% remained medically stable.<sup>17</sup> Even children with relatively mild asthma demonstrated increased asthma symptoms as adherence declined.<sup>11</sup> Nonadherent adults with asthma had more airway obstruction than adherent patients.<sup>18</sup> In large studies of managed care populations, decreasing use of ICS has been linked to increased risk of hospitalization.<sup>19</sup> Children who did not adhere to their asthma treatment regimen had poorer asthma control and required more urgent-care visits, steroid bursts and hospitalizations.<sup>17,20,21</sup> In a recent study of 18,456 Medicaid children with asthma, increasing adherence to controller medication was associated with higher cost but also decreasing odds of an ED visit.<sup>22</sup> Tragically, nonadherence has been associated with asthma-related deaths in children, particularly where psychologic dysfunction was observed in the patient or the patient's family.<sup>23</sup>

## Strategies to Change Patient Behavior

Numerous strategies to improve patient adherence have been tested, many in carefully conducted randomized clinical trials. While most of these interventions have been able to change patient or parent behavior, changes are often small and difficult to sustain. Further, effective interventions are often costly and require large amounts of healthcare provider time or supplementary staff. A Cochrane Collection meta-analysis of 69 randomized trials of adherence interventions, covering a large range of ages and diseases, reported that 40% produced an effect on both adherence and at least one clinical outcome. All involved complex interventions combining components such as information giving, reminders, self-monitoring, reinforcement, counseling, psychological therapy, crisis intervention and telephone follow-up.<sup>24</sup> A meta-analysis of 70 controlled studies of interventions to improve adherence across various chronic pediatric conditions, including asthma, diabetes, cystic fibrosis, cancer, sickle cell disease and gastrointestinal disorders, revealed moderate effect size in multicomponent behavioral interventions and small effect size from interventions limited to education and instruction.<sup>25</sup> Multicomponent behavioral programs again included a variety of interventions such as behavioral reinforcement, social support, computer and technology-based components, homework assignments and family and individual psychological counseling. Other promising strategies include the use of patient advocates or navigators<sup>26</sup> and introduction of innovative web-based technology into school-based clinics to improve care coordination and adherence.<sup>27</sup>

A recent consensus report from a group of 20 internationally recognized experts on adherence emphasized the essential importance of identifying simple, brief interventions that could be delivered by healthcare providers during the course of routine office care.<sup>28</sup> The challenge, then, becomes one of identifying interventions that are not costly, do not require a large amount of healthcare provider time and can be implemented during routine office visits. Do such interventions exist, and are they evidence based? A considerable amount of evidence indicates that key communication strategies exist that can change parent and patient behavior and are evidence-based, time-efficient and teachable to busy healthcare providers.

## Five Communication Strategies for Changing Patient Behavior

Behavioral scientists have long adopted a translational research approach to understanding and changing health behaviors. Much like 'bench' research, the process begins with studies that document frequencies, predictors and moderators of health behaviors. This information is used to build models, or theories, that explain health behaviors. Such models of behavior change are used, in turn, to translate theory to the 'bedside' by allowing behavioral scientists to develop and test interventions that change people's health behavior.<sup>29</sup> Strategies to change patient behavior have been rooted in a number of health behavior change frameworks. These include *patient-centered care*, *motivational interviewing*, *readiness to change* and *shared decision-making*. Each has produced evidence of the effectiveness of very specific communication strategies. These strategies are discussed below, along with evidence from each model that supports its use. The collective group of five strategies are presented here as an integrated program that can guide provider behavior during patient visits to increase treatment effectiveness and outcomes. Further, these strategies can enhance satisfaction from the encounter for both the family and the healthcare provider.

### 1. BUILD A RELATIONSHIP

Promoting strong adherence begins with the development of patient trust in the provider-patient relationship. Patients and parents are more likely to increase and accurately report their adherence levels, and to express satisfaction with their care, where healthcare providers demonstrate thorough information sharing, interpersonal sensitivity and partnership-building.<sup>30</sup> *Patient-centered care* embraces the concept that trust is established where the provider demonstrates genuine interest in and concern about the patient and considers the family's cultural traditions, personal preferences and values, current situations and lifestyle.<sup>31</sup> Trust begins with communication, including listening and exploring concerns. The first moment of interaction when the provider and patient come together sets the tone for the communication that will follow. Consensus recommendations indicate that very basic elements of communication that establish this foundation include adopting a friendly tone, greeting the family with a smile, and being aware of tone, pace, eye contact and other elements of nonverbal communication that establish genuine interest in the patient (Box 38-1).<sup>32</sup> Further, patients will be more adherent when physicians provide more information and are nonjudgmental, supportive and understanding.<sup>33</sup> Patient-centered care has been shown to

### BOX 38-1 KEY ELEMENTS OF THE INITIAL VISIT THAT HELP BUILD A POSITIVE RELATIONSHIP

- A warm smile moves mountains
- Greet and express interest in your patient
- Use tone, pace, eye contact and posture to show care and concern
- Use simple language and basic concepts
- Don't overload the patient or parent
- Be sensitive to cultural differences

Bayer-Fetzer Conference on Physician-Patient Communication in Medical Education. Essential elements of communication in medical encounters: the Kalamazoo Consensus Statement. *Acad Med* 2001;76:390–93.

### BOX 38-2 EXAMPLES OF QUESTIONS THAT HELP TO SET THE STAGE FOR PATIENT-CENTERED CARE

- What worries you about your child's asthma?
- What do you want to accomplish at this visit?
- What do you want to be able to do that you can't do now because of your asthma?
- What do you expect from treatment?
- What medicines have you tried?
- What other questions do you have for me today?

NAEPP Guidelines for the diagnosis and management of asthma. Expert Panel Report 2007;3.

improve health outcomes for a number of disorders including diabetes,<sup>34</sup> hypertension,<sup>35</sup> obesity<sup>36</sup> and asthma.<sup>37</sup>

Demonstration of interest and concern includes asking questions that allow the patient or parent to tell the physician about their worries, symptoms and hopes for the visit. In a survey study, 865 patients from three primary care practices completed a questionnaire inquiring about what the patient desired in a consultation with their physician. Factor analysis of the results identified three primary domains: (1) *communication*, which included listening, exploring concerns and providing information with clear explanations; (2) *partnership*, which included discussion with the physician to achieve common ground and mutual agreement about the problem and treatment; and (3) *health promotion*, which included information and encouragement to maintain health and reduce risks of future illness.<sup>38</sup> A systematic review of relevant literature revealed that physician questioning is an important part of effective communication that can exert positive influence on the patient's emotional wellbeing, symptom resolution and functional and physiologic improvement.<sup>39</sup> This approach has advantages for both the family and the provider. Taking the time to ask and answer patient questions is associated with greater physician job satisfaction and higher rates of adherence to medical treatment<sup>40</sup> and lower rates of medical errors.<sup>41</sup>

The NAEPP guidelines for the diagnosis and management of asthma<sup>15</sup> provide examples of questions that can be asked in the initial visit and help set the stage for positive communication (Box 38-2).

## 2. FOCUS ON LISTENING

Healthcare providers who want to be helpful to their patients by sharing important information about an illness, test results and treatment plans are often well-practiced at giving information, but may not always be as cognizant of the importance of listening. Time pressures add to the sense that the encounter must be brief and efficient, a tendency to ask questions that can be answered 'yes' or 'no' to limit discussion, and a desire to move briskly toward completion of the visit. The result may be that the family's concerns are not heard. The family's unheard concerns often undermine adherence.

In the context of the Health Beliefs Model, the parent's decision about whether or not to follow a treatment plan is largely influenced by their perception of the risks associated with the disease, and the risks and benefits introduced by the treatment.<sup>42</sup> For patients or parents of patients with asthma, concerns often include fears about medication side-effects, a perception that the medication is not helping, concerns about long-term dependence on the medication and the cost of the medication.<sup>43</sup> In a study of parents of 67 children with asthma, increased concerns about risks of taking asthma medications were associated with lower adherence; fewer concerns combined with a perception of benefit from the child's medication were associated with higher adherence.<sup>44</sup> When the patient or parent voices their concerns, the healthcare provider has an opportunity to discuss these concerns and perceptions, to provide more information and to discuss treatment options. When the discussion leads to a shift in the family's perception of the relative benefits of the medication over its risks, increased adherence is likely to follow.<sup>44,45</sup>

Patients who do not perceive a positive benefit-to-risk advantage to their treatment are likely to be ambivalent and uncommitted to a daily treatment regimen. Evidence of this ambivalence is seen in the finding that over half of 5,500 patients who filled an ICS prescription once did not return to refill within 12 months.<sup>8</sup> The technique of *motivational interviewing* is designed to increase patient and parent motivation by strategically helping to overcome ambivalence while avoiding confronting or lecturing the patient.<sup>46</sup> At the core of this technique are four important listening strategies: open-ended questions, affirmations, reflective listening and summary statements.<sup>47</sup>

*Open-ended questions* allow the patient and parent to 'tell their story', and contrast with closed-ended questions, which force the family into a yes-no response (e.g. 'Tell me about how you are using the asthma medication' rather than 'Are you taking your medication?').

*Affirmations* are positive statements that help to build rapport and encourage behavior change (e.g. 'I can see that you are really trying to get your child's asthma under control').

*Reflective listening*, arguably the most challenging of these listening skills, involves stating back to the patient and parent what the healthcare provider believes they have heard from the family. Reflective listening helps to ensure that the provider understands the patient's perspective while emphasizing positive statements about change. The seven types of reflective listening, from simplest to most complex, are listed in Table 38-1.

*Summary statements* are longer summaries of what the provider has heard from the patient or parent, and serve the purpose of providing a recap of key points, highlighting



**TABLE 38-1** Types of Reflections Used in Motivational Interviewing

<b>1. Repeating</b> Use to diffuse resistance	<b>Patient</b> 'I don't want to take my medication.'	<b>Healthcare Provider</b> 'You don't want to take your medication.'
<b>2. Rephrasing</b> Slightly alter what the patient says to provide the patient with a different point of view	<b>Patient</b> 'I want to take my medication, but I have trouble fitting it into my day.'	<b>Healthcare Provider</b> 'Taking your medication is important to you.'
<b>3. Empathic reflection</b> Provide understanding for the patient's situation	<b>Patient</b> 'You've probably never had to deal with anything like this.'	<b>Healthcare Provider</b> 'It's hard to imagine how I could possibly understand.'
<b>4. Reframing</b> Help the patient think about his or her situation differently	<b>Patient</b> 'I've tried to take my medication consistently, but I just can't seem to pull it off.'	<b>Healthcare Provider</b> 'You are persistent, even in the face of discouragement. Controlling your asthma is really important to you.'
<b>5. Feeling reflection</b> Reflect the emotional undertones of the conversation	<b>Patient</b> 'I know that not taking medication is bad for my asthma.'	<b>Healthcare Provider</b> 'You're worried about your asthma getting worse.'
<b>6. Amplified reflection</b> Reflect what the client has said in an exaggerated way. This encourages the client to argue less and can elicit the other side of the client's ambivalence	<b>Patient</b> 'My mom is totally exaggerating my symptoms. My asthma isn't that bad.'	<b>Healthcare Provider</b> 'There's no reason to be concerned about your asthma.' (said without sarcasm)
<b>7. Double-sided reflection</b> Acknowledge both sides of the patient's ambivalence	<b>Patient</b> 'Taking medications just takes away my freedom. It's such a hassle.'	<b>Healthcare Provider</b> 'On the one hand, you find that medication takes away your freedom. On the other hand, you said that your asthma symptoms limit your freedom by preventing you from doing things you enjoy. What do you make of this?'

Reprinted with permission, *J Allergy Clin Immunol* 2007;120(5).

the family's ambivalence and gently moving the patient toward a positive change (e.g. 'You'd like to really get your child's asthma under better control, and you think this medication is helping, but you are not convinced that this medication is safe enough to take for a long period of time'). Both reflective listening and summary statements help to crystallize where a behavior change is needed, and help to transition the discussion toward action.

### 3. COLLABORATE ON THE TREATMENT PLAN

*Patient-centered care* presumes that the provider is willing to put aside a paternalistic approach in which the patient is told what is wrong with them and what they need to do, and instead work toward a partnership in which the patient is heard, a discussion occurs and the two parties agree both on the goals of treatment as well as the treatment itself.<sup>48</sup> To accomplish this partnership, the provider must engage and listen to the patient and parent, showing sensitivity, interest, concern and comprehension of the family's message. Differences in goals and expectations must be discussed and resolved before the treatment plan is finalized. The partnership approach is favored by many patients. For example, a survey of patients following a consultation showed increased satisfaction where physicians were 'interested in what I think the problem is', 'interested in what treatment I want' and would 'discuss and agree with me on treatment'.<sup>38</sup> The NAEPP guidelines emphasize the importance of this relationship and provide recommendations on establishing a partnership with the patient and family (Box 38-3).

Establishing a partnership between the provider and family necessarily reflects a shift of authority within which the physician takes into account patients' concerns and preferences before making treatment recommendations. The degree to

#### BOX 38-3 STEPS TO DEVELOP AN ACTIVE PARTNERSHIP WITH THE PATIENT AND FAMILY

- Establish open communications
- Identify and address patient and family concerns about asthma and asthma treatment
- Identify patient/parent/child treatment preferences regarding treatment and barriers to its implementation
- Develop treatment goals together with patient and family
- Encourage active self-assessment and self-management of asthma
- Encourage adherence by:
  - choosing a treatment regimen that achieves outcomes and addresses preferences that are important to the patient/parent (Evidence B)
  - reviewing the success of the treatment plan with the patient/parent at each visit and making adjustments as needed (Evidence B)
- Tailor the asthma self-management teaching approach to the needs of each patient
- Maintain sensitivity to cultural beliefs and ethnocultural practices (Evidence C)

NAEPP Guidelines for the diagnosis and management of asthma. Expert Panel Report 2007;3.

which the provider defers to the patient or parent will depend on both the physician and family. Many physicians are most comfortable maintaining control of the treatment plan, and may do so while still adopting a sensitive patient-centered focus. Other physicians may be comfortable taking the partnership a step further, allowing the patient more control over the choice of treatment plan. This approach is adopted in the *shared decision-making* model, a communication approach that

attempts to increase concordance about treatment choices and goals by promoting greater involvement of the individual patient in deliberations about treatment options.<sup>49,50</sup> One study evaluated the effectiveness of shared decision-making in improving outcomes in adults aged 18 to 70 years with poorly controlled, mild to moderate persistent asthma. Healthcare providers were randomly assigned to one of three training conditions: (1) usual care (no training), (2) management by guidelines (training in following the evidence-based guidelines), and (3) shared decision-making (training in guidelines combined with shared decision-making). In the group of 170 patients of providers trained in shared decision-making, controller medication adherence improved from 40% at baseline to 70% following the intervention, significantly more than for the 331 patients in the other two conditions.<sup>51</sup> In another study, 808 women with asthma were interviewed about their healthcare experiences. Those who reported that their provider had entered into a negotiated treatment plan with the patient reported greater adherence and lower oral steroid use at follow-up.<sup>52</sup> Not all patients may prefer a shared decision-making approach. In a study where patients evaluated videos of two different types of consultations with a physician, one shared decision and one in which the physician was more directive, the directed approach was often preferred by older patients while the shared decision approach was often preferred by younger patients and those with higher education levels.<sup>53</sup>

#### 4. MANAGE TIME

With limitations in insurance reimbursement and a consequent need to see larger numbers of patients, physicians often experience significant pressure to limit the time they spend with each patient. Discussions about changing patient health behavior, therefore, are sometimes greeted with the concern that improved communication will mean large increases in time for each patient encounter. However, strategic time management and adoption of brief but effective communication strategies often results in meaningful changes in patient and parent motivation without increased encounter time. For example, a large randomized trial tested the effectiveness of educating primary care pediatricians in two interactive seminars that provided training in asthma management guidelines and communication skills. Half of the 100 pediatricians received the training. Compared to the control pediatricians, patients of the trained group reported more discussion about personal concerns and goals for treatment during office visits, and experienced fewer symptom days and emergency department visits over the ensuing year. Assessments of time spent with the family revealed that those pediatricians who had received the training spent no more time than control physicians during the initial visit, acute asthma visits or well-child visits.<sup>54</sup>

Effective time management begins with setting the agenda at the beginning of the visit. This includes asking the patient what they hope to accomplish ('What brings you here today?'; 'What are you hoping I might be able to do to help?'). The 'patient agenda' may differ from the 'physician agenda'.<sup>48</sup> Patients and parents may be reluctant to voice their agenda, feeling intimidated or worried about how their concerns will be heard by the physician.<sup>48</sup> However, when physicians proceed with their own presumed agenda and fail to elicit the family's agenda, outcomes are often less successful.<sup>55</sup> Asking families to voice their agenda does not carry with it a presumption that the

provider can address all concerns in the allotted time. Simply listening to and acknowledging the patient's concerns often provides an emotional relief to the patient. The provider must establish priorities with the patient or parent for this visit ('What is at the top of your list?'), consider the time available and make a plan that may include data collection and a follow-up visit.<sup>56</sup> It may be helpful for the provider to establish explicitly the boundaries for the visit and remind the patient of the time available.<sup>57,58</sup> 'We have about 15 minutes today, so let's decide together what is most important to accomplish. Then I'll order some tests and we'll have you schedule a follow-up visit. Would that be OK?'. Establishing interest in and concern for the patient does not mean giving unlimited time for the visit. Employing the techniques of reflective listening allows a means for the physician to summarize the information or concerns expressed by the patient or parent and move toward completion of the visit.

An additional communication strategy that is helpful both to managing time and assuring that the patient or parent understands what the provider means to communicate is the 'teach back' method.<sup>59</sup> This method consists of asking the patient to repeat in their own words what has been decided and what they need to do when they leave the office, and allows the provider to check the understanding of all plans and instructions ('I want to see if I have done a good job of explaining all of this to you. Can you tell me what we decided today, and what you're going to do about your child's asthma this week?').

#### 5. FOLLOW-UP

Providers have limited opportunity to influence the behavior of patients once they leave the office. However, if strong communication in the office has set the stage for motivating health-promoting behavior, follow-up contact can reinforce this motivation. Follow-up interventions may include return visits to the clinic, telephone calls and other media-based interventions.

NAEPP guidelines recommend follow-up visits at 2 to 6 weeks after the initiation of controller medication therapy, and intervals of 1 to 6 months for asthma well care visits. Because a large number of patients are almost immediately nonadherent following initial controller therapy prescription,<sup>8</sup> investment of efforts to increase adherence at the point of initiation of controller treatment may yield greatest return. Each follow-up visit provides an opportunity for discussion of the family's perceptions and concerns about treatment and, if necessary, renegotiation of the treatment plan. NAEPP guidelines include recommendations for questions that can be asked at follow-up visits that invite increased communication, provider-patient collaboration and treatment adherence (Box 38-4).

Recent evidence indicates strong potential for the employment of telecommunication technology to reach out to patients and encourage adherence. The rapid uptake of telecommunication technology has penetrated every demographic subgroup of the American public, which in turn means that there is the interest and opportunity to use technology to engage patients. Evidence is mounting to support adherence-enhancing strategies that include leveraging email,<sup>60,61</sup> text messaging<sup>62</sup> and interactive voice recognition technology<sup>63,64</sup> to activate patients and encourage better disease self-management. In a randomized study of a computerized speech recognition program designed to call patients with asthma to inquire about disease

### BOX 38-4 MONITORING PATIENT-PROVIDER COMMUNICATION AND PATIENT SATISFACTION

- 'What questions have you had about your child's asthma daily self-management plan and action plan?'
- 'What problems have you had following the daily self-management plan? The action plan?'
- 'How do you feel about making your own decisions about therapy?'
- 'Has anything prevented you from getting the treatment you need for your asthma from me or anyone else?'
- 'Have the costs of your child's asthma treatment interfered with your ability to get asthma care?'
- 'How satisfied are you with your asthma care?'
- 'How can we improve your asthma care?'

NAEPP Guidelines for the diagnosis and management of asthma. Expert Panel Report 2007;3.

control and promote adherence, patients who received the calls were significantly more likely to use their ICS and to have a routine asthma follow-up visit.<sup>64</sup> A similar system has been developed to promote diabetes self-management.<sup>65</sup>

## Conclusions

A large proportion of patients with asthma take less than half of their prescribed controller medication, and surprisingly many stop taking their controller medication altogether after an initial

filling at their pharmacy. Decreasing use of inhaled corticosteroids has been linked to worsening asthma symptoms and increased risk of hospitalization and death. Many interventions to improve patient adherence have been tested in controlled clinical trials; while some interventions increase adherence, many are complex, costly, time consuming and nearly impossible to adopt in independent primary care and allergy practices. Nonetheless, four decades of behavioral research and modeling have produced a number of communication strategies that may be used by healthcare providers to effectively change health behavior. From these, five key communication strategies with significant empirical support have been extracted and are presented here. These are: (1) build a relationship, (2) focus on listening, (3) collaborate on the treatment plan, (4) manage time, and (5) follow up. These communications strategies do not require a large amount of healthcare provider time, can be implemented during routine office visits and can change patient behavior. Realistically, these strategies will not transform every nonadherent patient into an effective illness self-manager, but employment of these strategies will improve adherence in many families. Furthermore, they can be used to effect change in other health behaviors, such as smoking cessation or weight loss. Finally, beyond behavior change, enhanced communication has been repeatedly shown to improve satisfaction in the interaction for both the family and the provider.

The complete reference list can be found on the companion Expert Consult website at <http://www.expertconsult.inkling.com>.

## KEY REFERENCES

- McGrady M, Hommel K. Medication adherence and health care utilization in pediatric chronic illness: a systematic review. *Pediatrics* 2013;132:730–40.
- Kahana S, Drotar D, Frazier T. Meta-analysis of psychological interventions to promote adherence to treatment in pediatric chronic health conditions. *J Pediatr Psychol* 2008;33:590–611.
- Apter A, Wan F, Reisine S, Bogen DK, Rand C, Bender B, et al. Feasibility, acceptability and preliminary effectiveness of patient advocates for improving asthma outcomes in adults. *J Asthma* 2013;50:850–60.
- Halterman J, Fagnano M, Montes G, Fisher S, Tremblay P, Tajon R, et al. The school-based preventive asthma care trial: results of a pilot study. *J Pediatr* 2012;161:1109–15.
- Bender B, Aloia M, Rankin A, Wamboldt F. Translational behavioral research in respiratory medicine. *Chest* 2011;139:1279–84.
- DiMatteo M. The role of effective communication with children and their families in fostering adherence to pediatric regimens. *Patient Educ Couns* 2004;55:339–44.
- Borrelli B, Riekert K, Weinstein A, Rathier L. Brief motivational interviewing as a clinical strategy to promote asthma medication adherence. *J Allergy Clin Immunol* 2007;120:1023–30.
- Irwin R, Richardson N. Patient-focused care: using the right tools. *Chest* 2006;130:73–82.
- Tamura-Lis W. Teach-back for quality education and patient safety. *Urol Nurs* 2013;33:267–71, 298.
- Vollmer W, Kirshner M, Peter SD, Drane A, Stibolt T, Hickey T, et al. Use and impact of an automated telephone outreach system for asthma in a managed care setting. *Am J Manag Care* 2006;12:725–33.

## REFERENCES

- Valenti W. Treatment adherence improves outcomes and manages costs. *AIDS Read* 2001;11:77–80.
- Baum D, Creer T. Medication compliance in children with asthma. *J Asthma* 1986;23:49.
- Bender B, Milgrom H, Rand CEA. Psychological factors associated with medication nonadherence in asthmatic children. *J Asthma* 1998;35:347–53.
- Urquhart J. Role of patient compliance in clinical pharmacokinetics. *Clin Pharmacokinet* 1994;27:202–15.
- Creer T, Bender B. Psychological disorders: research and clinical applications. Vol research. Washington DC: American Psychological Association; 1993.
- Le T, Bilderback A, Bender B, Wamboldt FS, Turner CF, Rand CS, et al. Do asthma medication beliefs mediate the relationship between minority status and adherence to therapy? *J Asthma* 2008;45:33–7.
- Walders N, Kopel S, Koinis-Mitchell D, McQuaid E. Patterns of quick-relief and long-term controller medication use in pediatric asthma. *J Pediatr* 2005;146:177–82.
- Bender B, Pedan A, Varasteh L. Adherence and persistence with fluticasone propionate/salmeterol combination therapy. *J Allergy Clin Immunol* 2006;118:899–904.
- Evans C, Eurich D, Remillard A, Shevchuk Y, Blackburn D. First-fill medication discontinuations and nonadherence to antihypertensive therapy: an observational study. *Am J Hypertens* 2012;25:195–203.
- Penning-van Beest F, van Herk-Sukel M, Gale R, Lammers J-W, Herings R. Three-year dispensing patterns with long-acting inhaled drugs in COPD: a database analysis. *Respir Med* 2011;105:259–65.
- Bender B, Rankin A, Tran S, Wamboldt F. Brief interval telephone surveys of medication adherence and asthma symptoms in the Childhood Asthma Management Program Continuation Study. *Ann Allergy Asthma Immunol* 2008;101:382–6.
- Bender B, Wamboldt F, O'Connor S, Rand C, Szeffler S, Milgrom H, et al. Measurement of children's asthma medication adherence by self report, mother report, canister weight, and Doser CT. *Ann Allergy Asthma Immunol* 2000;85:416–21.
- Szeffler S, Boushey H, Pearlman D. Time to onset of effect of fluticasone propionate in patients with asthma. *Allergy Clin Immunol* 1999;103:780–8.
- Bender B. Psychosocial factors mediating asthma treatment outcomes. London: Martin Dunitz Ltd; 2001.
- National Heart, Lung, and Blood Institute. Expert Panel report 3: guidelines for the diagnosis and management of asthma. Washington, DC: U.S. Department of Health and Human Services; 2007.
- Suissa S, Ernest P, Benayoun S, Baltzan M, Cai B. Low-dose inhaled corticosteroids and the prevention of death from asthma. *N Engl J Med* 2000;343:332–6.
- Milgrom H, Bender B, Ackerson L, Bowry P, Smith B, Rand C. Non-compliance and treatment failure in children with asthma. *J Allergy Clin Immunol* 1996;98:1051–7.
- Horn C, Clar T, Cochrane G. Compliance with inhaled therapy and morbidity from asthma. *Respir Med* 1990;84:67–70.
- Williams L, Pladevall M, Xi H, Peterson EL, Joseph C, Lafata JE, et al. Relationship between adherence to inhaled corticosteroids and poor outcomes among adults with asthma. *J Allergy Clin Immunol* 2004;114:1288–93.
- Bender B, Milgrom H, Rand C. Nonadherence in asthmatic patients: is there a solution to the problem? *Ann Allergy Asthma Immunol* 1997;79:177–86.
- McGrady M, Hommel K. Medication adherence and health care utilization in pediatric chronic illness: a systematic review. *Pediatrics* 2013;132:730–40.
- Herndon J, Mattke S, Cuellar A, Hong S, Shenkman E. Anti-inflammatory medication adherence, healthcare utilization and expenditures among Medicaid and Children's Health Insurance program enrollees with asthma. *Pharmacoeconomics* 2012;30:397–412.
- Strunk R. Identification of patients at risk and intervention. *J Allergy Clin Immunol* 1987;80:472–7.
- Kahana S, Drotar D, Frazier T. Meta-analysis of psychological interventions to promote adherence to treatment in pediatric chronic health conditions. *J Pediatr Psychol* 2008;33:590–611.
- Haynes R, Ackloo E, Sahota N, McDonald H, Yao X. Interventions for enhancing medication adherence (review). *Cochrane Collab* 2008;2:1–19.
- Apter A, Wan F, Reisine S, Bogen DK, Rand C, Bender B, et al. Feasibility, acceptability and preliminary effectiveness of patient advocates for improving asthma outcomes in adults. *J Asthma* 2013;50:850–60.
- Halterman J, Fagnano M, Montes G, Fisher S, Tremblay P, Tajon R, et al. The school-based preventive asthma care trial: results of a pilot study. *J Pediatr* 2012;161:1109–15.
- Van Dulmen S, Sluijs E, Van Dijk L, De Rider D, Heerdink R, Bensing J. International expert forum on patient adherence. Furthering patient adherence: a position paper of the international expert forum on patient adherence based on an internet forum discussion. *BMC Health Serv Res* 2008;8:47.
- Bender B, Aloia M, Rankin A, Wamboldt F. Translational behavioral research in respiratory medicine. *Chest* 2011;139:1279–84.
- DiMatteo M. The role of effective communication with children and their families in fostering adherence to pediatric regimens. *Patient Educ Couns* 2004;55:339–44.
- Webb S, Litton E, Bamed K, Crozer. Treatment goals: health care improvement through setting and measuring patient-centred outcomes. *Crit Care Resusc* 2013;152:143–6.
- Bayer-Fetzer. Essential elements of communication in medical encounters: the Kalamazoo Consensus Statement. Paper presented at: Bayer-Fetzer Conference on Physician-Patient Communication in Medical Education; 2001.
- Hall J, Roter D, Katz N. Meta-analysis of correlates of provider behavior in medical encounters. *Med Care* 1988;26:657–75.
- Kinmonth A, Woodcock A, Griffin S, Spiegel N, Campbell M. Randomized controlled trial of patient centered care of diabetes in general practice: impact on current well-being and future disease risk. The Diabetes Care From Diagnosis Research Team. *BMJ* 1998;317:1202–8.
- Boulware L, Daumit G, Frick K, Minkovitz C, Lawrence R, Powe N. An evidence-based review of patient-centered behavioral interventions for hypertension. *Am J Prev Med* 2001;21:221–32.
- Ockene I, Hebert J, Ockene J, Saperia G, Stanek E, Nicolosi REA. Effect of physician-delivered nutrition counseling training and an office-support program on saturated fat intake, weight, and serum lipid measurements in a hyperlipidemic population: Worcester Area Trial for Counseling in Hyperlipidemia (WATCH). *Arch Intern Med* 1999;159:725–31.
- Wilson S, Strub P, Buist A, Verghese S, Brown N, Lunda V, et al. Does involving patients in treatment decisions improve asthma controller medication adherence? Paper presented at: 102nd International Conference of the American Thoracic Society. San Diego, California; 2006.
- Little P, Everitt H, Williamson I, Warner G, Moore M, Gould C, et al. Preferences of patients for patient centred approach to consultation in primary care: observational study. *BMJ* 2001;322:468–72.
- Stewart M. Effective physician-patient communication and health outcomes: a review. *Can Med Assoc* 1995;152:1423–32.
- DiMatteo R, Sherbourne C, Hays R, Ordway L, Kravitz RL, McGlynn EA, et al. Physicians' characteristics influence patients' adherence to medical treatment: results from the medical outcomes study. *Health Psychol* 1993;12:93–102.
- Woolf S, Kuzel A, Dovey S, Phillips RJ. A string of mistakes: the importance of cascade analysis in describing, counting, and preventing medical errors. *Ann Fam Med* 2004;2:317–26.
- Rosenstock I. Historical origins of the health belief model. *Health Educ Monogr* 1974;2.
- Bender B, Bender S. Barriers to asthma treatment adherence: responses to interviews, focus groups, and questionnaires. *Immunol Allergy Clin North Am* 2005;25:107–30.
- Conn K, Halterman J, Fisher S, Yoos H, Chin N, Szilagyi P. Parental beliefs about medications and medication adherence among urban children with asthma. *Ambul Pediatr* 2005;5:306–10.
- Horne R. Compliance, adherence, and concordance implications of asthma treatment. *Chest* 2006;130:655–72S.
- Miller W, Rollnick S. Motivational interviewing: preparing people to change addictive behavior. New York: Guilford; 1991. p. 191–202.
- Borrelli B, Riekert K, Weinstein A, Rathier L. Brief motivational interviewing as a clinical strategy to promote asthma medication adherence. *J Allergy Clin Immunol* 2007;120:1023–30.
- Irwin R, Richardson N. Patient-focused care: using the right tools. *Chest* 2006;130:73–82.
- Bosworth H, Olsen M, Neary AEA. Take control of your blood pressure (TCYB) study: a multifactorial tailored behavioral and educational intervention for achieving blood pressure control. *Patient Educ Couns* 2008;70:338–47.
- Noble P, Fuller-Lafreniere S, Meftah M, Dwyer M. Challenges in outcome measurement: discrepancies between patient and provider definitions of success. *Clin Orthop Relat Res* 2013;471:3437–45.
- Wilson S. Does shared treatment decision-making improve asthma adherence and outcomes? Paper presented at: American Thoracic Society. San Diego, CA; 2006.



52. Clark N, Ko Y, Gong Z, Johnson T. Outcomes associated with a negotiated treatment plan. *Chron Respir Dis* 2012;9:175–82.
53. McKinstry B. Do patients wish to be involved in decision making in consultation? A cross sectional survey with video vignettes. *BMJ* 2000;321:867–71.
54. Cabana M, Slish K, Evans D, Mellins RB, Brown RW, Lin X, et al. Impact of physician asthma care education on patient outcomes. *Pediatrics* 2006;117:2149–57.
55. Barry C, Bradley C, Britten N, Stevenson F. Patients' unvoiced agendas in general practice consultations: qualitative study. *BMJ* 2000;520:1246–50.
56. Smith R. Patient-centered interviewing: an evidence-based method. 2nd ed. Lippincott Williams & Wilkins; 2002. p. 35–71.
57. Marvel M, Epstein R, Flowers K, Beckman HB. Soliciting the patient's agenda: have we improved? *J Am Med Assoc* 1999;281:283–7.
58. Tamura-Lis W. Teach-back for quality education and patient safety. *Urol Nurs* 2013;33:267–71, 298.
59. Villaire M, Mayer G. Low health literacy: the impact on chronic illness management. *Prof Case Manag* 2007;12:213–16.
60. Hughes L, Done J, Young A. Not 2 old 2 TXT: there is potential to use email and SMS text message healthcare reminders for rheumatology patients up to 65 years old. *Health Informatics* 2011;17:266–76.
61. Sternfeld B. Improving diet and fitness with ALIVE. A worksite randomized trial. *Am J Prev Med* 2009;36:475–83.
62. Montes J, Gomez-Beneyto M, Maurino J. A short message service (SMS)-based strategy for enhancing adherence to antipsychotic medication in schizophrenia. *Psychiatry Res* 2012;200:89–95.
63. Stacy J, Schwawrtz S, Ershoff D, Shreve M. Incorporating tailored interactive patient solutions using interactive voice response technology to improve statin adherence: results of a randomized clinical trial in a managed care setting. *Popul Health Manag* 2009;12:241–54.
64. Vollmer W, Kirshner M, Peter SD, Drane A, Stibolt T, Hickey T, et al. Use and impact of an automated telephone outreach system for asthma in a managed care setting. *Am J Manag Care* 2006;12:725–33.
65. Goldman R, Sanchez-Hernandez M, Ross-Degnan D, Piette J, Trinacty C, Simon S. Developing an automated speech-recognition telephone diabetes intervention. *J Qual Health Care* 2008;20:264–70.

# New Directions in Asthma Management: A Tale of Two Cities

STANLEY J. SZEFLER

## KEY POINTS

- Recent statistics show that asthma deaths and hospitalizations are decreasing, but there are still health disparities in that the African American/black population bears a heavier burden of the disease.
- There is a need to *standardize* and *harmonize* our approach to asthma care; a continuing need for *communication* among the various stakeholders; and also a need for *collaboration* in order to address the health disparities in asthma care.
- In managing asthma today the focus is on achieving asthma control through an effort to minimize asthma impairment, specifically factors that affect day-to-day symptoms, and risk for future asthma events, such as asthma exacerbations, progression and adverse effects of medications.
- New medications have been developed and the positive responses to them have been linked to certain biomarkers, e.g. sputum or blood eosinophil count with anti-IL-5 therapy and serum periostin with anti-IL-13 therapy.
- There is emerging concern regarding the potential for overlap of asthma and COPD in certain patients, called the 'asthma-COPD overlap syndrome', and growing interest in preventing this phenomenon.

## Introduction

'It was the best of times, it was the worst of times.' This well-known quote opens Charles Dickens' popular novel 'A Tale of Two Cities.' Charles Dickens characterized the bleak times of an industrializing country having personally experienced many trials and tribulations while growing up and then reflecting on the bad and good times as an adult. While painting a very depressing picture of strife and struggle, there are threads of optimism throughout his work and even glimmers of humor. His writing and public speaking brought attention to the problems and ultimately had impact on changing society. However, he did not live long enough to see the changes that followed.

In many ways analogies can be made between the situation described by Dickens and the healthcare system. The poor seek help. The system is complicated. There is a growing concern that two levels of care are emerging. This situation is of great concern worldwide, but especially in the USA, where the economy is strong yet the healthcare system is in apparent disarray. A careful examination of various national healthcare systems reveals that each has its benefits and limitations.<sup>1</sup>

Certainly, asthma provides a good model for the healthcare situation generally. There continues to be a high burden of asthma among the poor. On the other hand, scientific advancements are being made regarding the use of patient characteristics, biomarkers and genetics to assist in individualizing care. New medications are being developed but there are financial limits to their application.

The review on new directions in asthma management in the previous edition of this book concentrated on the understanding of the therapeutic interventions at the time and the possibilities for improving asthma management and perhaps halting the progression of the disease.<sup>2</sup> It also emphasized an integrated approach to patient care. At the time, there were serious deficiencies in the healthcare system that influenced access to health care. The reported decline in asthma mortality and morbidity was encouraging, but it was pointed out that this could be deceptive since the decline did not encompass all racial/ethnic groups. Recent statistics have shown that asthma deaths and hospitalizations are indeed decreasing, but there are still health disparities in that the African American/black population bears a heavier burden of the disease (Figure 39-1).<sup>3</sup>

Concerted efforts are now being directed toward understanding this phenomenon and recommendations are being made to integrate the various national resources available to improve outcomes of asthma care for children in the USA. The application of electronic medical records and additional methods of surveying disease management should prompt improvements in medical care.

This chapter will describe the current state of asthma care, using some quotes from Dickens' writing to highlight the important points. Perhaps this will inspire a reflection on the past to help set a vision for the future. The key message is that there is a need to *standardize* and *harmonize* our approach to asthma care; a continuing need for *communication* among the various stakeholders; and a need for *collaboration* in order to address health disparities in asthma care.

## Asthma: Past, Present and Future

In the Christmas Carol, Dickens wrote 'It is a fair, even-handed, noble adjustment of things, that while there is infection in disease and sorrow, there is nothing in the world so irresistibly contagious as laughter and good humor.' In the past, asthma was treated as an episodic disease, primarily with bronchodilators (Figure 39-2). As it began to be realized that asthma has an inflammatory component, inhaled corticosteroids became the cornerstone of asthma management. Advances in extending the duration and specificity of the bronchodilator led to the development of the long-acting  $\beta$ -adrenergic agonists and their combination with inhaled corticosteroids. Additional medications

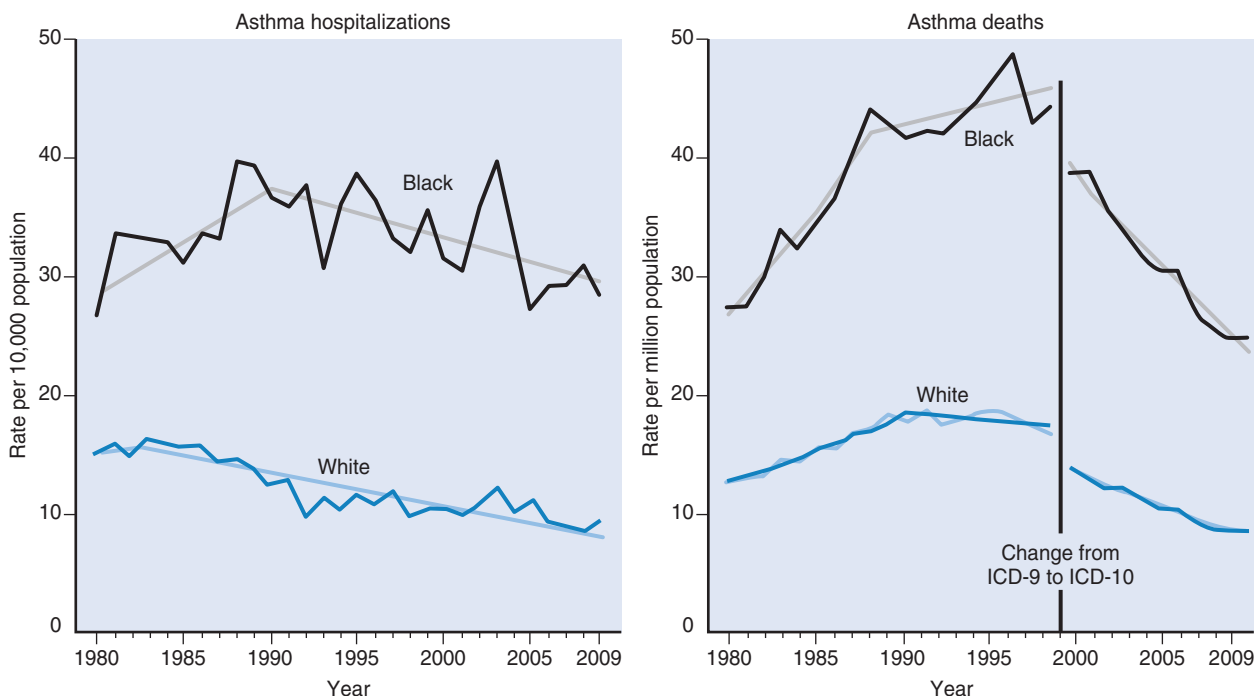

Notes: Population-based rates are age adjusted to the 2000 standard population. Light blue and gray lines show the modeled trend estimated by Joinpoint. Inflection points represent a change in the annual percent change.

**Figure 39-1** Asthma hospitalization rates and asthma death rates (population-based) by race: United States, 1980–2009. (From Moorman JE, Akinbami LJ, Bailey CM, National Surveillance of Asthma, et al.<sup>3</sup>)

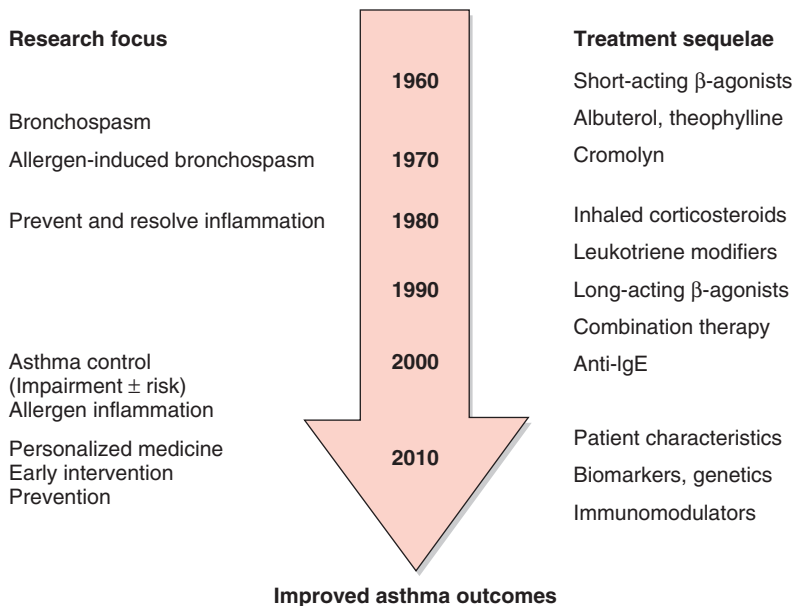

**Figure 39-2** Timeline of advances in asthma care showing the interaction of research focus and development of new medications.

introduced in the last 20 years included leukotriene modifiers and anti-IgE therapy. Asthma guidelines were also introduced and revised over the past 30 years and helped to standardize and harmonize asthma care.

Currently, we have the Global Initiative for Asthma<sup>4</sup> as a template global strategy for managing asthma. This strategy is updated regularly and the latest version was released in May 2014. Many countries have their own specific guidelines, such as the National Asthma Education and Prevention Program *Guidelines for the Diagnosis and Management of Asthma* in the

USA.<sup>5</sup> These guidelines were last released in 2007 and placed an emphasis on asthma control. They are currently being reviewed for revision and there are several areas that need to be updated to integrate recent studies that impact asthma management.<sup>6</sup> The importance of guidelines in asthma management is addressed by Allan Becker in Chapter 29.

In managing asthma today the focus is on achieving asthma control through an effort to minimize asthma impairment, specifically factors that affect day-to-day symptoms, and risk for future asthma events, such as asthma exacerbations,

progression and adverse effects of medications. The issues for current management in young and older children include asthma worsening due to exercise, infection and living in the inner city, as well as severe asthma are comprehensively addressed in Chapters 31–34, 36 and 37.<sup>7,8</sup> Up to date information related to immunology and pulmonary physiology have been summarized (see Chapters 28 and 30). Information is also provided on methods to improve asthma management by improving medication adherence (see Chapter 38), as well as supporting students with asthma through school-centered asthma programs (see Chapter 35).

Some key observations have been made that can be useful in designing strategies for future asthma management, including the variability in response to medications, the association of a positive response to certain biomarkers and patient characteristics, and the potential to utilize intermittent inhaled corticosteroid therapy in place of or in addition to daily administration of inhaled corticosteroids. There is growing concern about the management of patients with difficult-to-control asthma. Of interest, new medications have been developed and the positive response to them have been linked to certain biomarkers, e.g. sputum or blood eosinophil count with anti-IL 4 therapy and serum periostin with anti-IL13 therapy.<sup>7,8</sup>

For the future, there is emerging concern regarding the potential for overlap of asthma and chronic obstructive pulmonary disease (COPD) in certain patients, called the ‘asthma-COPD overlap syndrome’, and growing interest in preventing this phenomenon.<sup>4</sup> There is also a growing need to address the special needs of children and asthma management must be viewed across the ages. Of great interest is the development of strategies to prevent asthma.<sup>9,10</sup>

## Key Steps in Moving Asthma Care Forward

### MANAGED CARE TO ORGANIZED CARE

The USA is gradually moving from a system of managed care to one of more collaborative care. In the managed care system, the care of the patient is directed toward the medical home where the primary care physician oversees the direction of care and is responsible for a number of individuals and their ongoing care, including referral to specialty care when needed. The reimbursement system is changing from a fee per service to a certain cost per individual. However, the specialist still is largely paid on a fee per service basis for medical consultations and procedures. The next step is to integrate the specialist into the system and creating what is called a medical neighborhood in order to provide comprehensive care and reimbursement; this is called bundled care. However, it will be a challenge for each specialty area to determine where it fits in this system of care.<sup>11</sup> For example, for asthma care, specialty areas include allergy and immunology and also pulmonary medicine. In this setting, either specialty or both working together could oversee the care of patients with asthma within a certain medical system. That is, the specialist or preferably a multidisciplinary team would monitor the care of all asthma patients within the medical system, including those seen personally. This requires careful analysis of data regarding patient visits, medical costs and urgent care utilization within a system. These are all indicators of asthma control for individual patients and within a medical system.

### PERSONALIZED MEDICINE

Over the past 15 years, only one new medication has been introduced for asthma therapy, namely anti-IgE and specifically omalizumab. The use of this medication is linked to having a certain level of serum IgE as well as demonstration of specific allergen sensitivity. On the horizon is the imminent approval of a set of new medications that are directed toward blocking key cytokines related to asthma. Of interest, the response to these medications has been linked to the level of the identified biomarkers. For example, the use of lebrikizumab, an anti-IL-13 antibody, has been linked to a high level of periostin or exhaled nitric oxide, while the response to anti-IL4 and anti-IL5, e.g. dupilumab and mepolizumab, has been linked to a certain level of sputum or blood eosinophils.<sup>12,13</sup> These observations have brought attention to the use of biomarkers to predict response to asthma therapy. Since these medications are likely to be expensive, at least initially, there is a need to develop criteria to allow the careful selection of patients for their use, and also to realize that the cost of the medication may greatly outweigh the anticipated savings for medical care. A potential benefit, however, is that perhaps one of these medications when used early in treatment may actually alter the course of the disease. This would represent lifetime cost savings rather than immediate cost savings related to reducing costs of hospitalizations over a short-term period, such as a year or two. This will raise questions regarding reapportioning the costs of care.

In the interim, it will be important to maximize the use of available medications before considering these more expensive alternatives, including improved methods to enhance adherence to conventional therapy. To do this, we will need to standardize and harmonize medical care, while improving communication and setting up systems of collaboration.

### SUPPORT SYSTEMS FOR MEDICAL CARE

Chapter 35 on school-centered asthma programs raises a number of issues around asthma care. Schools can be a source of support for the medical system in monitoring asthma control, education of children regarding the management of chronic disease and reporting back to the clinician certain observations related to the child’s medical care.

In order to do this successfully, we must *standardize* medical forms of communication, such as the so-called asthma action plan that is designed for administering medications in the school setting as prevention for exercise-induced asthma, as well as administering rescue therapy for symptoms. Some experts prefer to call this form the school asthma care plan. This differs from the comprehensive treatment plan that the patient receives from the clinician and could be called the home asthma treatment plan. In order to appreciate and support the medical treatment plan, it would be useful for the school, particularly the school nurse and the medical support team in the school setting, to see both treatment plans. The school treatment plan gives the directions for school-administered medications in the school setting, e.g. by the nurse or a designated assistant. Access to the home treatment plan would allow the school nurse to see the whole management plan in order to assess adherence to the plan in the school setting and support appropriate medication inhaler technique and asthma knowledge. Standardizing the name for each treatment plan as well as standardizing the



format for these two communication documents is necessary and will help in communication electronically.

In addition, it would be useful if the electronic medical record systems could alert clinicians to potential risk factors for loss of control, e.g. a certain constellation of symptom clusters, seasonal exacerbations, or biologic risk factors, that could help predict an asthma exacerbation in order to take steps to prevent it. Systems must continue to be standardized as we gain more knowledge about risk factors for exacerbations, as well as progression and even onset of disease.

In order to effectively communicate within the system and co-manage patients, we must also improve methods to *harmonize* asthma care. Asthma guidelines have helped in designing a uniform approach to management. Asthma guidelines are available for individual countries and are sometimes modified for regional application. The Global Initiative for Asthma has helped to present a global strategy for asthma care.<sup>4</sup> In regards to a harmonized implementation effort, the Easy Breathing program is a cost-effective, evidence-based, asthma management program for healthcare providers that includes training and tools to improve the recognition and management of childhood asthma.<sup>14,15</sup> The program has led to improvements for inner city children with asthma in reducing hospitalizations, outpatient visits and asthma-specific emergency department visits, which have varied among black and Hispanic children.<sup>15</sup> Additional information about the Easy Breathing program can be obtained from their website at <http://www.connecticutchildrens.org/community-child-health/easy-breathing-asthma/>.

The asthma specialist is in a unique position and has the expertise to provide guidance and oversight for asthma care in the medical system, including the support of school-centered asthma programs. It is important for the specialist to encourage *harmonization* of the approach to asthma care by applying an evidence-based guidelines approach to asthma care. This will lead to consistency across the community and less confusion. There is also a need for ongoing bidirectional *communication* between community asthma care providers and the schools, which should prompt a spirit of *collaboration* and *coordination* in managing asthma among schools, healthcare providers and families. We must also improve electronic communication between asthma specialists and primary care providers within medical systems and across medical systems. Key stakeholders in this coordinated effort include students, families, school nurses (central role for the school), school administration, school personnel (teachers, coaches, etc.), clinicians including primary care physicians and specialist care, and payers (families' ability to acquire multiple quick relief inhalers, reimbursement for disease management, case management and care coordination efforts). A concerted effort should result in better asthma control with reduced costs from urgent care utilization.

Our own experience with a collaborative program being implemented and evaluated in Denver, Colorado and Hartford, Connecticut, 'Building Bridges for Asthma Care', is an attempt to improve communication between schools and medical care providers. The Building Bridges school-centered asthma program incorporates many of the effective components described above, including case management according to the asthma risk level for the individual student, use of school asthma care plans, onsite quick relief inhalers, asthma education for students, families and school staff, and the build out and optimization of existing information technology platforms

in schools (see Chapter 35). This program is the first to combine a multifaceted school-centered program and a multifaceted asthma care provider program, while identifying barriers to overcome and the potential synergies to be realized. Models of asthma care that place schools at the center or core of the model and coordinate evidence-based asthma care are applicable nationwide and may serve as a model for managing other chronic illnesses.

Our Building Bridges program seeks to utilize school nurses to identify students with asthma based on parent history, assess their level of severity based on a set of key questions, monitor their school absence, physical activity and ongoing asthma control as well as school performance, and communicate this information to their parents and healthcare provider. It is hoped that this level of communication will be useful in better preparing students for school and also preventing seasonal exacerbations. Communication between the provider and the school may also help to support the overall school and home asthma care plan. In certain situations, directly observed therapy is needed to assure adherence to the treatment schedule.<sup>16</sup> An important feature of any school-centered asthma program is finding sustainability mechanisms. This may come through reorganization of school staffing or some unique mechanisms of payment to supplement schools that are struggling with budget appropriations. Indeed, communication and collaboration among key stakeholders are essential in providing students with the necessary assistance in managing their asthma in the school setting to improve school attendance and academic performance, and to encourage physical activity to reduce the health risks of obesity. It is also our hope that national medical and nursing societies will support these efforts and make them ongoing community engagement and quality improvement features of their continuing education and maintenance of certification programs.

## Addressing Asthma Mortality, Morbidity and Origins

Another quote from Charles Dickens, this time from 'Great Expectations' is, 'Suffering has been stronger than all other teaching, and has taught me to understand what your heart used to be. I have been bent and broken, but – I hope – into a better shape.' Indeed, we have learned a lot from past suffering related to asthma, and we now look to a brighter future. Effective treatments have now been developed not only to relieve but also to prevent symptoms including exacerbations. However, much has still to be learned if the progression of the disease is to be altered and eventually its onset prevented. The tools to accomplish this task are being developed.

There are reasons for optimism that overall management of asthma can improve. For example, there are devices that can effectively measure adherence to asthma therapy. Prompts can then be included in order to remind the patient to take his/her medication and the clinician can use motivational techniques to encourage better self-care. Telemedicine is being developed in order to facilitate communication between clinicians at a distance and also for patients from the home or school setting to their own clinician.

In relation to the science around asthma care, a systems biology approach is being developed to understand better ways to predict response to medications and also to monitor disease

activity. However, such approaches will not only add to the cost of medical care but will lead to the implementation of medications, such as immunomodulators, that may be more costly than conventional therapy. The benefits and risks of such an approach will need to be carefully assessed in terms of lifetime benefits. The pharmaceutical industry has responded by developing these new medications, and partnerships with academic centers and providers will be necessary in order to advance this area of discovery in order to meet regulatory requirements and assess cost-benefit. This will involve use of such medications at the early stage of disease onset or perhaps even before it occurs if indicated by a certain risk profile. Hopefully, this new form of treatment for childhood asthma coupled with preventative measures, such as reduction in tobacco smoke exposure and smoking avoidance, will lead to an improved quality of life and reduced risk of chronic obstructive airway disease as children

reach adulthood. If executed effectively, this effort should have a marked impact on reducing the prevalence of lung disease in the future and the consequent burden of respiratory illness on society.

#### ACKNOWLEDGEMENTS

The author is supported by the Colorado Department of Public Health and Environment, Caring for Colorado Foundation, the McCormick Foundation and Glaxo Smith Kline FLV116794. Also supported by NHLBI AsthmaNet U10 HL098075 and in part by Colorado CTSA Grant UL1 RR025780 from NCCR/NIH and UL1 TR000154 from NIH/NCATS.

The complete reference list can be found on the companion Expert Consult website at <http://www.expertconsult.inkling.com>.

#### KEY REFERENCES

3. Moorman JE, Akinbami LJ, Bailey CM, National Center for Health Statistics, et al. National Surveillance of asthma: United States, 2001–2010. *Vital Health Stat* 2012;2:1–67.
4. Global Initiative for Asthma. Global Strategy for Asthma Management and Prevention, <[www.ginasthma.org](http://www.ginasthma.org)>; 2014.
6. Szefer SJ. Is it time to revise the asthma guidelines? *J Allergy Clin Immunol* 2011;128:937–8.
9. Busse W, Erzurum SC, Blaisdell CJ, Noel P. Executive summary: NHLBI workshop on the primary prevention of chronic lung diseases. *Ann ATS* 2014;11:S123–4.
11. Huang X, Rosenthal MB. Transforming specialty practice – the patient-centered medical neighborhood. *N Engl J Med* 2014;370:1376–9.
14. Cloutier MM, Jones GA, Hinckson V, Wakefield DB. Effectiveness of an asthma management program reducing disparities in care in urban children. *Ann Allergy Asthma Immunol* 2008;100:545–50.
16. Halterman JS, Szilagyi PG, Fisher SG, Fagnanao M, Tremblay P, Conn KM, et al. Randomized controlled trial to improve care for urban children with asthma: Results of a school-based asthma therapy trial. *Arch Pediatr Adolesc Med* 2011;165:262–8.

## REFERENCES

1. Reid TR. *The Healing of America, A Global Quest for Better, Cheaper, and Fairer Health Care*. New York: The Penguin Press; 2009.
2. Szeffler SJ. New directions in asthma management. In: Leung DYM, Sampson HA, Geha RS, Szeffler SJ, editors. *Pediatric Allergy: Principles and Practice*. 2nd ed. Philadelphia, PA: WB Saunders; 2010.
3. Moorman JE, Akinbami LJ, Bailey CM, National Center for Health Statistics, et al. National Surveillance of asthma: United States, 2001–2010. *Vital Health Stat* 2012;2:1–67.
4. Global Initiative for Asthma. *Global Strategy for Asthma Management and Prevention*, <[www.ginasthma.org](http://www.ginasthma.org)>; 2014.
5. National Institutes of Health, National Heart, Lung, and Blood Institute. *National Asthma Education and Prevention Program. Expert Panel Report 3: Guidelines for the Diagnosis and Management of Asthma*. NIH Publication No. 07-4051, <<http://www.nhlbi.nih.gov/guidelines/asthma/index.htm>>; 2007.
6. Szeffler SJ. Is it time to revise the asthma guidelines? *J Allergy Clin Immunol* 2011;128:937–8.
7. Corren J, Lemanske RF, Hanania NA, Korenblat PE, Parsey MV, Arron JR, et al. Lebrikizumab treatment in adult with asthma. *N Engl J Med* 2011;365:1088–98.
8. Wenzel S, Ford L, Pearlman D, Spector S, Sher L, Skobieranda F, et al. Dupilumab in persistent asthma with elevated eosinophil levels. *N Engl J Med* 2013;368:2455–66.
9. Busse W, Erzurum SC, Blaisdell CJ, Noel P. Executive summary: NHLBI workshop on the primary prevention of chronic lung diseases. *Ann ATS* 2014;11:S123–4.
10. Jackson DJ, Hartert TV, Martinez FD, Weiss ST, Fahy JV. Asthma: NHLBI Workshop on the primary prevention of chronic lung diseases. *Ann ATS* 2014;11:S139–45.
11. Huang X, Rosenthal MB. Transforming specialty practice – the patient-centered medical neighborhood. *N Engl J Med* 2014;370:1376–9.
12. Pavord ID, Korn S, Howarth P, Bleecker ER, Buhl R, Keene ON, et al. Mepolizumab for severe eosinophilic asthma (DREAM) a multi-centre, double-blind, placebo-controlled trial. *Lancet* 2012;380:651–9.
13. Ortego H, Li H, Suruki R, Albers F, Gordon D, Yancey S. Cluster analysis and characterization of response to mepolizumab: a step closer to personalized medicine for patients with severe asthma. *Ann ATS* 2014;11:1011–17.
14. Cloutier MM, Jones GA, Hinckson V, Wakefield DB. Effectiveness of an asthma management program reducing disparities in care in urban children. *Ann Allergy Asthma Immunol* 2008;100:545–50.
15. Cloutier MM, Grosse SD, Wakefield DB, Nurmagambetov TA, Brown CM. The economic impact of an urban asthma management program. *Am J Manag Care* 2009;15:345–51.
16. Halterman JS, Szilagyi PG, Fisher SG, Fagnanao M, Tremblay P, Conn KM, et al. Randomized controlled trial to improve care for urban children with asthma: Results of a school-based asthma therapy trial. *Arch Pediatr Adolesc Med* 2011;165:262–8.

# Mucosal Immunology: An Overview

M. CECILIA BERIN | MIRNA CHEHADE

## KEY POINTS

- The gastrointestinal associated lymphoid tissue protects the vast surface of the gastrointestinal tract from pathogens while remaining tolerant to antigens from food and commensal microbiota.
- Several specialized antigen uptake mechanisms exist for the sampling of luminal contents by antigen-presenting cells in the Peyer's patch and lamina propria.
- Antigen-presenting cells of the gastrointestinal tract, including dendritic cells and macrophages, maintain immune tolerance to antigens from food and commensal microbiota by generating regulatory T cells.
- Immune homeostasis is regulated by factors in the diet and by the microbiota.
- Secretory IgA provides an immune barrier by excluding antigens from uptake, but antibodies including IgA, IgG and IgE can function as antigen uptake mechanisms across the intestinal epithelium.

## Introduction

The gastrointestinal (GI) tract is the largest immunologic organ in the body. The small intestine itself has the largest surface area in the GI tract due to structural features including villi and microvilli. The purpose of this extensive surface is to facilitate nutrient absorption from ingested foods. From the stomach to the rectum, a single layer of columnar epithelial cells separates the external environment of the gastrointestinal lumen from the body proper. The lumen contains a myriad of microorganisms and dietary proteins. The challenge from an immune perspective is to guard the extensive surface area of the GI tract from breaches by microorganisms, in particular pathogenic microorganisms. In the small intestine, the main antigenic load is from ingested food. Along the proximal to distal axis, the food antigen load decreases as it is digested and absorbed, but the microbial load increases. In the large intestine, there are  $10^{10}$ – $10^{12}$  organisms per gram of dry luminal contents.<sup>1</sup> The intestinal immune system must remain nonreactive or tolerant to antigens from food or commensal flora, yet retain the ability to mount a protective immune response to enteropathogens. This function is accomplished by the gastrointestinal associated lymphoid tissue (GALT) that has adapted to its unique environment.

## Structure of the Gastrointestinal Associated Lymphoid Tissue (GALT)

The gastrointestinal tract has several types of organized lymphoid tissue comprising the GALT. Underlying the intestinal

epithelial layer is a loose connective tissue stroma called the lamina propria (LP), containing a resident population of CD4 and CD8 T lymphocytes, plasma cells, macrophages, dendritic cells (DCs), eosinophils and innate lymphoid cells (ILCs). The LP of the small and large intestine is drained via lymphatics that empty into the mesenteric lymph nodes (MLN). Migratory DCs capture antigens in the LP and deliver those antigens to the MLN. The MLN is a typical secondary lymph node with organized B cell follicles and paracortical T cell areas. Peyer's patches (PP) are lymph nodes found within the mucosal wall and have direct access to the intestinal lumen. PP are large and visible by eye as bulges on the serosal surface of the intestine. In addition to PPs, the intestine contains smaller structures called isolated lymphoid follicles (ILF), each containing a single B cell follicle with an overlying follicular epithelium. Mouse intestine contains an abundance of these small organized structures.<sup>2,3</sup> The precursor of the ILF is the cryptopatch, comprised of clusters of lymphoid tissue inducer cells.<sup>4</sup> Bacterial signals promote the enlargement of the ILFs through the recruitment of B cells.<sup>5,6</sup> The MLN, PP and ILF comprise the inductive sites in the gastrointestinal tract. In addition, T lymphocytes are normally found between epithelial cells (intraepithelial lymphocytes, or IELs). IELs are predominantly CD8<sup>+</sup> T cells in the small intestine and have an oligoclonal repertoire. The immune cells of the LP and the IELs comprise the effector cells of the GALT and are responsible for both the maintenance of tolerance to harmless antigens and immunity against pathogens. [Figure 40-1](#) shows a schematic of the structure of the GALT.

## Mechanisms of Antigen Sampling in the Intestinal Mucosa

Food protein antigens are digested by a combination of gastric acid, pancreatic proteases and brush border peptidases, resulting in a mixture of amino acids and di- and tri-peptides, which are then absorbed by the intestinal epithelial cells. Dietary antigens that escape proteolysis in the lumen can be taken up by the intestine in various ways. Soluble antigens are taken up by enterocytes via fluid phase endocytosis by the microvillous membrane, transported in small vesicles and larger phagosomes, and then digested when lysosomes combine to form phagolysosomes. Intact molecules that remain after digestion are deposited in the extracellular space by exocytosis.<sup>7</sup> As a result, approximately 2% of intact proteins reach the intestinal lymph and portal circulation under physiologic conditions.<sup>8</sup> Goblet cells have also been identified as portals of uptake of soluble antigens, delivering these antigens to subepithelial DCs.<sup>9</sup>

Particulate antigens are poorly sampled by enterocytes, where the glycocalyx provides a barrier to even relatively small particles.<sup>10</sup> PPs are overlaid by specialized epithelial cells, referred to as membranous or microfold (M) cells.<sup>11</sup> M cells that



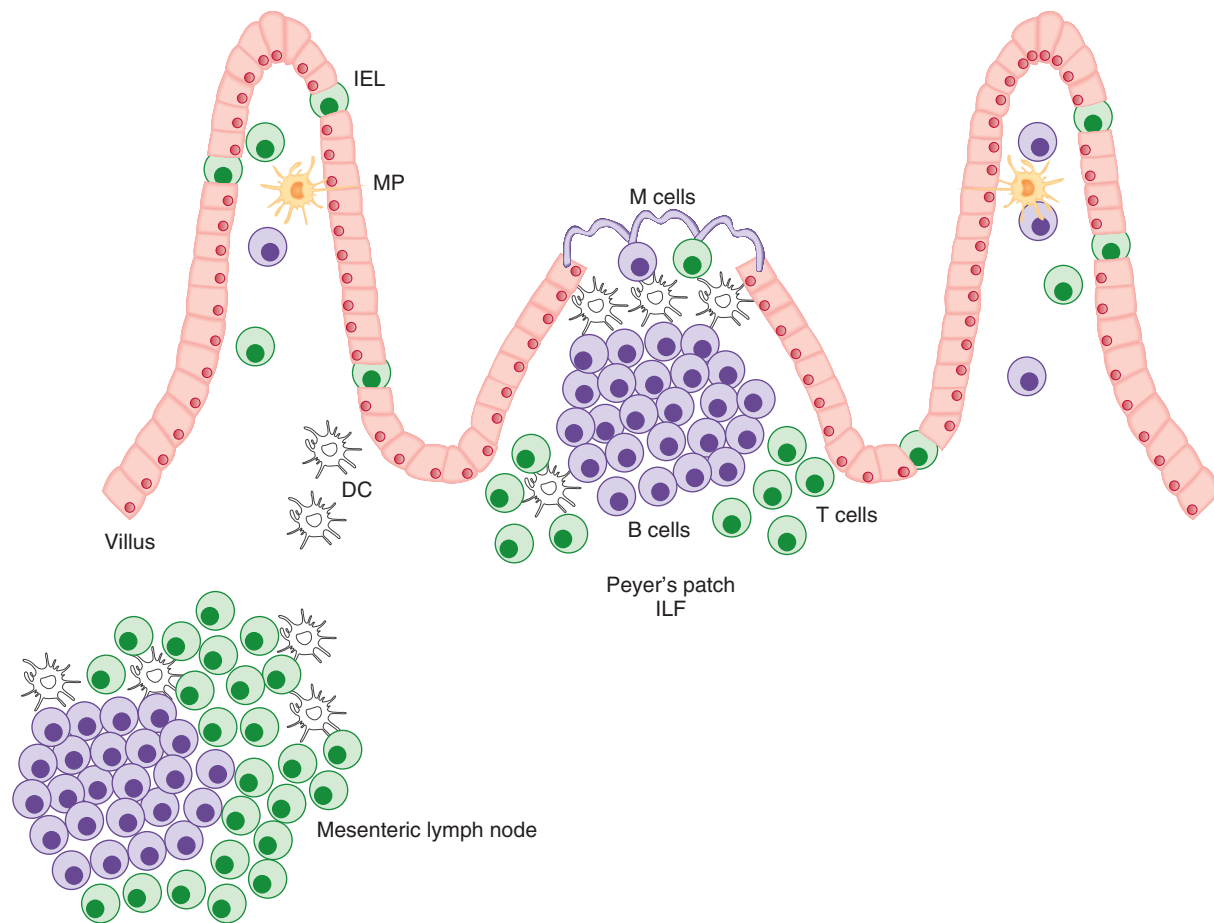

**Figure 40-1** Structure of the GALT. Organized lymphoid structures in the gastrointestinal tract include the mesenteric lymph node (MLN) that drains the mucosa via the lymphatics. Peyer's patches and isolated lymphoid follicles (ILF) are present within the mucosal wall and are covered by specialized antigen sampling cells called M cells. Dendritic cells (DC) continuously migrate from the lamina propria into the MLN to present antigen. Organized lymphoid structures contain B cell follicles surrounded by T cell areas. Within the lamina propria are scattered T cells, B cells, macrophages (MP) and DCs. A population of intraepithelial lymphocytes (IEL) is also found through the gastrointestinal tract. A single layer of columnar epithelium separates the mucosal immune system from the luminal contents.

overlay PPs have a reduced glycocalyx layer and shortened microvilli that allow for binding of particles that cannot adhere to enterocytes.<sup>10</sup> In addition, they have a sparse flattened cytoplasm and enhanced endocytic activity, allowing rapid antigen delivery into the subepithelial dome region of the Peyer's patch. The subepithelial dome is rich in DCs that process and present antigen to T lymphocytes or transfer antigen to B lymphocytes.

The intestinal mucosa is densely populated with a network of DCs that function to acquire antigen, migrate to T cell areas of lymph nodes, and present antigen to naïve T cells. They can acquire this antigen after it has been transcytosed across enterocytes, M cells or goblet cells as outlined above. In addition, mononuclear phagocytes with dendritic morphology have been shown to extend dendrites between enterocytes into the intestinal lumen.<sup>12,13</sup> These dendrites are functional, as antigen sampling extensions can acquire luminal bacteria.<sup>12,13</sup> This mononuclear phagocyte subset is more similar to macrophages than DCs by transcriptional profiling<sup>14</sup> and does not migrate to the lymph nodes under steady-state conditions.<sup>15</sup> These antigen-sampling resident macrophages provide antigen to DCs, which are the cells that carry antigen to the draining lymph nodes and

can prime naïve T cells.<sup>16</sup> Figure 40-2 outlines these major pathways of antigen uptake.

Antigen transport across the intestinal barrier has been shown to be altered by immunization or allergic sensitization, either enhancing<sup>17,18</sup> or inhibiting<sup>19</sup> uptake. As discussed in detail later, IgA-, IgG- and IgE-facilitated antigen sampling have been documented in the intestinal mucosa.

## Normal Immune Response to Sampled Antigens in the Intestine

Food contains a diverse mix of antigens that are capable of stimulating immune responses if administered by other routes. Administration of antigens by the oral route is one of the most effective means of inducing tolerance. The process of oral tolerance was first defined experimentally in laboratory rodents that displayed systemic unresponsiveness to immunization with antigens to which they had previously been fed. Tolerance can be transferred to a naïve animal by transferring T lymphocytes,<sup>20,21</sup> demonstrating that this is an active immune-mediated process. Oral tolerance has also been demonstrated in humans

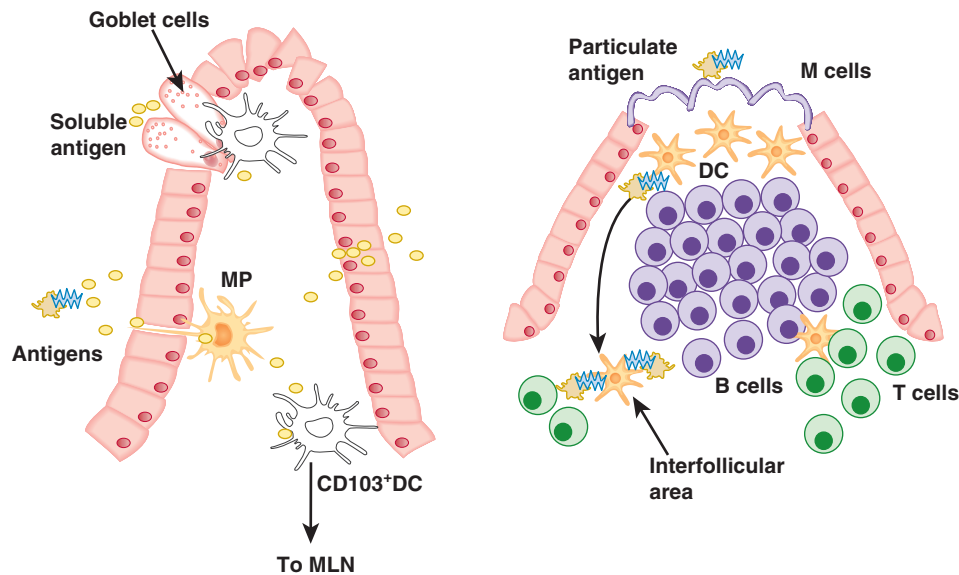

**Figure 40-2** Antigen uptake in the intestine. In the intestinal villus (left), antigen can reach subepithelial dendritic cells (DCs) by several routes. Macrophages (MP) can send extensions between enterocytes to sample particulate antigens directly from the lumen and transfer these antigens to DCs. Alternatively, soluble antigens can be taken up by fluid phase endocytosis by enterocytes and be deposited in the lamina propria for uptake by macrophages or DCs. Goblet cells can also function as conduits for delivery of antigen to DCs. DCs migrate from the lamina propria to the mesenteric lymph node (MLN), where antigen can be presented to naïve T cells. In the Peyer's patch (right), M cells are specialized for uptake of particulate antigens that are delivered to DCs in the subepithelial space. These DCs can then traffic to the interfollicular areas of the Peyer's patch for presentation to T cells (green) or interaction with B cells (blue).

by feeding a neo-antigen prior to immunization with that antigen.<sup>22,23</sup>

Several different phenotypes of regulatory T cells have been shown to contribute to oral tolerance induction to fed antigens, including CD8<sup>+</sup> T<sub>REGS</sub>,<sup>24</sup> and different subsets of CD4<sup>+</sup> T<sub>REGS</sub>.<sup>20,21</sup> Of the CD4<sup>+</sup> T<sub>REGS</sub>, T helper 3 (Th3) cells and Foxp3<sup>+</sup>CD25<sup>+</sup> cells have been described as contributing to oral tolerance to fed antigens. Th3 cells produce TGF- $\beta$  together with IL-4 and IL-10, can be identified by surface expression of latency-associated peptide (LAP), and were first described using myelin basic protein (MBP)-specific CD4<sup>+</sup> T cell clones from the mesenteric lymph nodes of MBP-fed mice. Adoptive transfer of these cells from MBP-fed mice suppressed experimental allergic encephalomyelitis, an experimental model of multiple sclerosis.<sup>25</sup> Inhibition of TGF- $\beta$  with neutralizing antibodies can abrogate tolerance responses in this model.<sup>26,27</sup> CD25<sup>+</sup>Foxp3<sup>+</sup> T<sub>REGS</sub> include both thymic-derived natural T<sub>REGS</sub> (nT<sub>REGS</sub>) and induced T<sub>REGS</sub> (iT<sub>REGS</sub>) generated in the periphery. There are data both for and against a role for nT<sub>REGS</sub> in oral tolerance.<sup>26,28</sup> Feeding mice induces a population of antigen-specific T regulatory cells that express similar markers as natural T regulatory cells (CD25<sup>+</sup>, Foxp3<sup>+</sup> and CTLA-4) and mediate regulatory responses via TGF- $\beta$  but not IL-10.<sup>26</sup> Specific depletion of all Foxp3<sup>+</sup> T cells, followed by a rest period to allow nT<sub>REGS</sub> to rebound, provides supporting evidence that iT<sub>REGS</sub> are the most critical regulatory population mediating oral tolerance.<sup>29</sup> Tr1 cells are another regulatory subset that secrete IL-10. Although several studies indicate that IL-10 is dispensable for the induction of oral tolerance to foods, IL-10 is critical for the suppression of inflammatory responses initiated by the intestinal microbiota.<sup>30</sup>

Naïve T cells must be instructed to become regulatory in phenotype rather than becoming effector Th1, Th2 or Th17 cells. There is growing evidence that the milieu in which food

antigens are presented to the naïve T cells by DCs is a critical factor promoting the development of regulatory T cells in the intestine.

## The Role of Intestinal Dendritic Cells in Tolerance and Immunity

An abundant network of DCs surrounds the epithelium and fills the lamina propria. The role of DCs in both tolerance and immunity in the intestinal mucosa was first explored using the growth factor FMS-like tyrosine kinase 3 ligand (Flt3L) to expand the DC population in mice. Flt3L treatment enhanced tolerance responses to an innocuous antigen when it was delivered orally.<sup>31</sup> In addition, when antigen was administered with adjuvant to elicit protective immunity, DC expansion also enhanced that response.<sup>32</sup> These studies show that, like elsewhere in the body, DCs are essential for the initiation of an active CD4<sup>+</sup> T cell response, whether regulatory, or effector Th1, Th2 or Th17 in nature.

In the lamina propria, DCs bearing the marker CD103 are derived from DC progenitors and constitutively express CCR7, a chemokine receptor required for lymph node homing.<sup>33</sup> These CD103<sup>+</sup> DCs are required for the generation of oral tolerance.<sup>15,34</sup> CD103<sup>+</sup> DCs from the mesenteric lymph node preferentially induce the development of Foxp3<sup>+</sup> regulatory T cells that express chemokine receptors and adhesion molecules that support homing back to the intestine. This resulting phenotype is induced by release of retinoic acid and expression of TGF- $\beta$  by the DCs.<sup>35,36</sup> The regulatory activity of these DCs is modified by environmental factors. Local tissue factors, including the cytokine GM-CSF<sup>37</sup> and mucins produced by the epithelium,<sup>38</sup> enhance the regulatory function of CD103<sup>+</sup> DCs. In contrast, administration of the mucosal adjuvant cholera toxin can

modify these CD103<sup>+</sup> DCs into immunogenic rather than tolerogenic DCs.<sup>39</sup>

## Macrophages Have a Regulatory Phenotype in the Intestine

Macrophages are the most abundant phagocytic cells resident in the small and large intestinal LP. They form a band of cells directly beneath the surface epithelium distinct from the localization of DCs.<sup>40</sup> Like DCs, macrophages can take up antigen and present it to T lymphocytes; however macrophages are not migratory, and do not reach lymph nodes for interaction with naïve T cells. Macrophages from the human intestine are adept at both phagocytosis and killing of microbes after uptake.<sup>41,42</sup> Therefore, they function as a secondary barrier after the epithelium in preventing the influx of microbes from the gut lumen into the body proper. Macrophages from the intestinal mucosa of mouse and human are nonresponsive to microbial stimuli compared to monocytes or macrophages from other sites.<sup>42,43</sup> This was shown to be due to TGF- $\beta$  released from the intestinal stroma in humans<sup>42</sup> or autocrine effects of IL-10 in the mouse.<sup>43</sup> IL-10 is clearly important for immune homeostasis in the intestine because mice lacking IL-10 develop spontaneous colitis,<sup>44</sup> as do mice lacking IL-10 receptor specifically in macrophages.<sup>45</sup> Although resident macrophages do not have access to naïve T cells to initiate tolerance to fed antigens, they play an important role in the expansion of T<sub>REGS</sub> during the generation of tolerance.<sup>29</sup> CX<sub>3</sub>CR1<sup>+</sup> macrophages extend dendrites across the epithelium to interact with luminal contents. In mice genetically deficient in CX<sub>3</sub>CR1, these dendrites cannot form, and oral tolerance to fed antigens is impaired. The role of gastrointestinal DCs and macrophages in the generation of tolerance and immunity is outlined in Figure 40-3.

## Homing of Lymphocytes to the Intestine

Lymphocytes that differentiate in the inductive sites of the GALT into effector or regulatory T cells or IgA-producing B cells home preferentially to the intestinal lamina propria to

carry out their function.<sup>46,47</sup> Targeted homing of lymphocytes is determined by expression of specific adhesion molecules and chemokine receptors.<sup>48</sup> Homing to the intestine is mediated by the adhesion molecule  $\alpha$ 4 $\beta$ 7 binding to MAdCAM on high endothelial venules.<sup>49</sup> In addition, the chemokine receptor CCR9 promotes migration to the small intestine where constitutive expression of the ligand CCL25 is found.<sup>50,51</sup> Migration to the large intestine is promoted by the chemokine receptor CCR10 binding to its ligand CCL28.<sup>52,53</sup> The intestinal migratory phenotype is imprinted on lymphocytes by stromal cells,<sup>54</sup> as well as the CD103<sup>+</sup> population of DCs in the MLN,<sup>35,55</sup> via a retinoic-acid dependent mechanism.

## Microbial Regulation of Mucosal Immunity

The gastrointestinal mucosa is often described as being in a state of 'physiologic inflammation'. In mice, the genetic deletion of a wide range of immunoregulatory genes results in colitis, a phenotype that is commonly absent if the mice are raised in germ-free conditions.<sup>56</sup> Although microbial signals can induce inflammation and tissue damage if not appropriately controlled, these signals are also necessary for the health of the organism. Our intestinal microbiota contributes locally to the digestion of nutrients, regulates the epithelial barrier, and is essential for maturation of the mucosal immune system in addition to having systemic effects on metabolism and the neuroendocrine system.<sup>57</sup>

Mice reared under germ-free conditions have poorly developed lymphoid structures in the gastrointestinal tract, and colonization with a single strain of bacteria is sufficient to induce significant changes in gene expression in the intestinal epithelium and maturation of the mucosal immune system.<sup>58</sup> Different organisms have differing effects on the development of effector and regulatory responses in the gastrointestinal tract. Segmented filamentous bacteria that are in intimate contact with mouse intestinal epithelium promote the development of Th17 responses in the gastrointestinal tract.<sup>59</sup> *Bacteroides fragilis* and several Clostridia strains promote the development of regulatory T cells.<sup>60,61</sup> Humoral immunity is also significantly regulated by the commensal microbiota. Germ-free mice have

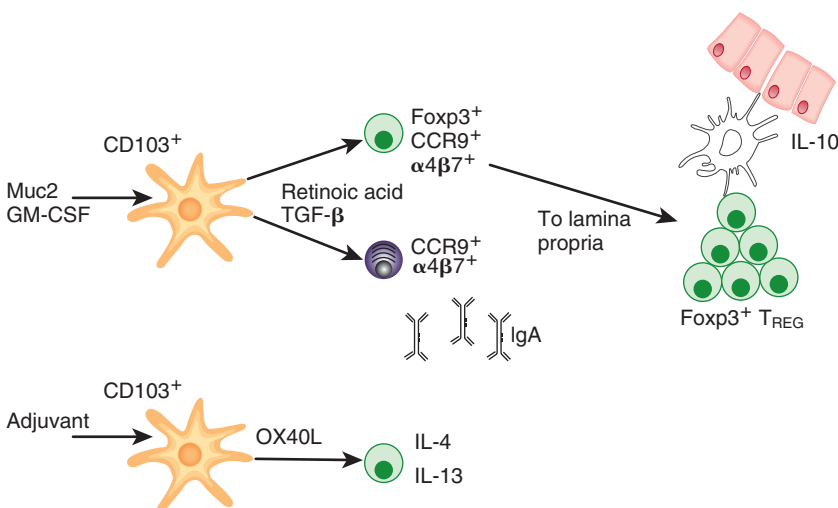

**Figure 40-3** Function of antigen presenting cells in the intestine. A subset of DCs in the lamina propria express the marker CD103. These are migratory DCs that acquire antigen and traffic to the MLN. In normal conditions, CD103<sup>+</sup> DCs prime naïve T cells and B cells to generate a gut-homing phenotype expressing CCR9 and  $\alpha$ 4 $\beta$ 7. CD103<sup>+</sup> DCs promote the generation of regulatory T cells expressing Foxp3, and promote IgA secretion from B cells. The T<sub>REGS</sub> migrate to the lamina propria, where they interact with IL-10-expressing CX<sub>3</sub>CR1<sup>+</sup> macrophages and are expanded in response to antigen. Mucosal factors such as GM-CSF and mucins (Muc2) promote the regulatory phenotype of DCs, while the presence of the mucosal adjuvant cholera toxin induces CD103<sup>+</sup> DCs to up-regulate OX40L and induce Th2 skewing from responder T cells.

reduced levels of all isotypes of antibodies with the exception of IgE, which is uniquely elevated.<sup>62</sup> IgA production is carefully regulated by the commensal microbiota, and the specificity of the IgA response adapts to respond to changes in intestinal microbial populations.<sup>63</sup>

Cellular and humoral immune responses in the gastrointestinal tract are influenced by the commensal microbiota, and it is therefore not surprising that the microbiota is a key factor in the development of tolerance or allergy in the gastrointestinal tract. Germ-free mice have a reduced capacity for the generation of oral tolerance, and conversely show increased susceptibility to allergic sensitization through the oral route.<sup>64</sup> Colonization with normal microbiota, or with *Clostridia* strains, results in the expansion of regulatory T cells and the suppression of allergic sensitization.<sup>64</sup> Toll-like receptor (TLR)2, TLR4 and TLR9 are host receptors that have been shown to contribute to tolerogenic effects of the intestinal microbiota.<sup>65–67</sup> Metabolic products of the microbiota, such as short chain fatty acids, also promote a tolerogenic tone in the intestine.<sup>68</sup> Although the microbiota has generally been shown to be tolerogenic, susceptibility to food allergy has been shown to be transmissible in mice,<sup>69</sup> suggesting that there may be pro-allergenic bacterial strains as well as pro-tolerogenic strains, although these have yet to be identified.

## Influence of Diet on Mucosal Immunity

Diet and the microbiota are the two factors with the strongest impact on the mucosal immune system, although we are only beginning to gain an understanding of the impact of diet on immunity. The microbiota is significantly altered by changes in diet,<sup>70</sup> demonstrating an indirect mechanism of dietary regulation of the mucosal immune system. Dietary components can also have direct effects on the mucosal immune system. The vitamin A metabolite retinoic acid is best known for promoting the generation of regulatory T cells as outlined above, although the impact of retinoic acid is not always regulatory. In the

presence of the inflammatory cytokine IL-15, retinoic acid can amplify inflammatory responses and in this way has been shown to contribute to intestinal damage in a murine model of celiac disease.<sup>71</sup> Vitamin D promotes homing of lymphocytes to the gastrointestinal tissue and suppresses IL-17 production,<sup>72</sup> and vitamin D insufficiency results in significant reduction of a unique population of regulatory intraepithelial lymphocytes bearing the marker CD8 $\alpha\alpha$ .<sup>73</sup> Aryl hydrocarbon receptor ligands (AHR ligands) that are found in the diet are also regulatory<sup>74</sup> and promote the development of immune tolerance to foods.<sup>75</sup> In contrast to these regulatory elements of the diet, a high fat diet can have proinflammatory effects by altering cytokines from innate lymphoid cells that regulate epithelial barrier function.<sup>76</sup>

## Humoral Immune Responses in the Intestine

The intestinal mucosa is a rich site of antibody production, particularly secretory IgA. Naïve B cells in the MLN and PP are activated by binding to their antigen, proliferate, and with T cell help differentiate into antibody-secreting cells or memory B cells. GALT DCs promote the differentiation of B cells into IgA-secreting cells, as well as up-regulating CCR9 and  $\alpha 4\beta 7$  on B cells to promote homing of cells to the lamina propria.<sup>46</sup> CCR10 is also expressed on a subset of antibody-secreting cells and contributes to homing to the large intestinal mucosa.<sup>52,77</sup> Immunoglobulins play an important role in neutralization of pathogens, and also function together with epithelial-expressed receptors as specific antigen-sampling mechanisms in the intestinal mucosa. IgA is the most abundant immunoglobulin produced within the intestinal mucosa, but there is also evidence for a significant contribution of IgG to host defense against enteropathogens. In the context of food allergy, IgE and its receptor CD23 also come into play as an antigen-sampling mechanism and inducer of inflammatory reactions in the intestine. **Figure 40-4** shows the function of these immunoglobulin receptors in the intestine.

**Figure 40-4** Immunoglobulin secretion and antibody-facilitated antigen uptake in the intestine. Epithelial cells express receptors for IgA (pIgR), IgG (FcRn) and IgE (CD23). All three receptors can facilitate the secretion of their respective immunoglobulins in a basal-to-apical direction. IgA can facilitate uptake of antigen by M cells through Dectin-1. FcRn captures IgG-antigen complexes for delivery to dendritic cells (DCs) and promotes the generation of tolerance to foods or immunity to pathogens. When allergen-specific IgE is produced and secreted (i.e. during food allergy), IgE-allergen complexes can be captured from the apical side by CD23 and transported to the basal side of the epithelium. IgE-allergen complexes can then degranulate effector cells or induce the migration of DCs through epithelial-derived chemokines.

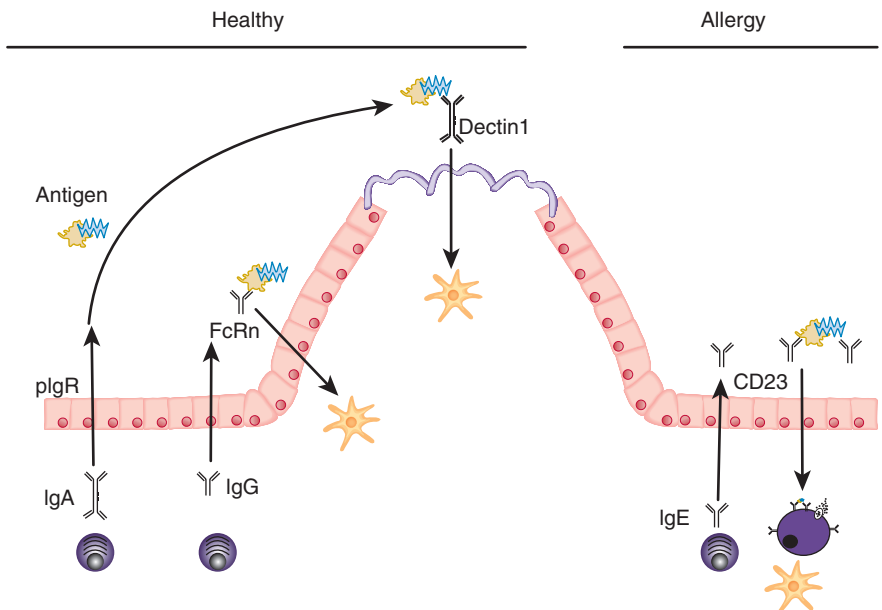



## IgA/pIgR

Eighty percent of IgA-secreting cells are found in the gastrointestinal mucosa, and daily production of IgA outpaces that of all other immunoglobulin isotypes combined.<sup>78</sup> IgA in plasma occurs primarily as monomers, but IgA in mucosal secretions is comprised of polymeric IgA (2–4 molecules) joined at the Fc region by a joining 'J' chain and secretory component that is a fragment of the polymeric Ig receptor (pIgR). There are two IgA subclasses, IgA1 and IgA2, that differ in their resistance to intestinal proteases (IgA2 being more resistant than IgA1). pIgR is expressed on the intestinal epithelium and transports polymeric IgA from the basolateral face into the intestinal lumen. Pentameric IgM is also transported into the lumen via the pIgR. Binding of dimeric IgA and pentameric IgM to pIgR occurs through the J chain that connects the Ig subunits. Each molecule of pIgR can only perform one transport of Ig, as the extracellular portion is cleaved to form the secretory component.

Secretory IgA has been shown to selectively bind to M cells via the interaction of constant domains<sup>79</sup> with Dectin-1.<sup>80</sup> Antigens tagged to IgA are taken up by M cells and delivered to DCs in the PP<sup>81</sup> where they induce an immunoglobulin response. Thus IgA may selectively allow for controlled entry of antigens into the PP while preventing broad access to the remaining intestinal mucosa.

## IgG/FcRn

Like IgA, IgG is also found in intestinal secretions in significant quantities. In rodents, the neonatal Fc receptor for IgG (FcRn) is expressed in the intestine prior to weaning and facilitates the transfer of passive immunity from the mother via colostrum. In humans, passive immunity is delivered via the placenta, but FcRn is expressed in the intestine and is maintained throughout adult life.<sup>82</sup> This suggests a function for FcRn beyond transfer of passive immunity. In vitro systems have shown that FcRn functions as a bi-directional transporter of IgG.<sup>83</sup> The development of transgenic mice expressing human FcRn into

adulthood has uncovered a critical role for FcRn as an antigen-sampling mechanism in vivo. IgG is secreted into the intestinal lumen via FcRn, where it binds to its antigens and can be recaptured by FcRn and transported into the intestinal LP.<sup>84</sup> Antigen is then delivered to subepithelial DCs that can generate a functional T cell response. This pathway was shown to promote clearance of the murine enteric pathogen *Citrobacter rodentium*.<sup>85</sup> Induction of tolerance in the neonate by antigen exposure via IgG-containing breast milk has also been shown to be mediated via FcRn-facilitated uptake and delivery to DCs.<sup>86</sup>

## IgE/CD23

IgE is not generally thought of as a secretory immunoglobulin, but it can be detected in the intestinal secretions and stool of subjects with food allergy.<sup>87,88</sup> The low-affinity IgE receptor CD23 is constitutively expressed by human intestinal epithelial cells.<sup>89,90</sup> Similar to studies with FcRn, CD23 has been shown to function as a bi-directional transporter of IgE across gastrointestinal as well as respiratory epithelial cells.<sup>89,91</sup>

## Conclusions

The mucosal immune system is tightly regulated to prevent inappropriate immune reactions to food antigens or the commensal flora, and is responsible for guarding a vast surface area against pathogenic entry. Antigens can gain access to the mucosal immune system by a number of different mechanisms including direct DC uptake and antibody-facilitated antigen uptake. The normal response to food antigens is an active tolerance response mediated by regulatory T cells and induced by gastrointestinal DCs and macrophages. Microbiota and diet are critical factors in the maintenance of gastrointestinal immune homeostasis.

The complete reference list can be found on the companion Expert Consult website at <http://www.expertconsult.inkling.com>.

## KEY REFERENCES

- McDole JR, Wheeler LW, McDonald KG, Wang B, Konjufca V, Knoop KA, et al. Goblet cells deliver luminal antigen to CD103+ dendritic cells in the small intestine. *Nature* 2012;483:345–9.
- Rescigno M, Urbano M, Valzasina B, Francolini M, Rotta G, Bonasio R, et al. Dendritic cells express tight junction proteins and penetrate gut epithelial monolayers to sample bacteria. *Nat Immunol* 2001;2:361–7.
- Hadis U, Wahl B, Schulz O, Hardtke-Wolenski M, Schippers A, Wagner N, et al. Intestinal tolerance requires gut homing and expansion of FoxP3+ regulatory T cells in the lamina propria. *Immunity* 2011;34:237–46.
- Coombes JL, Siddiqui KR, Arancibia-Carcamo CV, Hall J, Sun CM, Belkaid Y, et al. A functionally specialized population of mucosal CD103+ DCs induces Foxp3+ regulatory T cells via a TGF-beta and retinoic acid-dependent mechanism. *J Exp Med* 2007;204:1757–64.
- Kuhn R, Lohler J, Rennick D, Rajewsky K, Muller W. Interleukin-10-deficient mice develop chronic enterocolitis. *Cell* 1993;75:263–74.
- Zigmond E, Bernshtein B, Friedlander G, Walker CR, Yona S, Kim KW, et al. Macrophage-restricted interleukin-10 receptor deficiency, but not IL-10 deficiency, causes severe spontaneous colitis. *Immunity* 2014;40:720–33.
- Blumberg R, Powrie F. Microbiota, disease, and back to health: a metastable journey. *Sci Transl Med* 2012;4:137rv7.
- Kau AL, Ahern PP, Griffin NW, Goodman AL, Gordon JI. Human nutrition, the gut microbiome and the immune system. *Nature* 2011;474:327–36.
- Noval Rivas M, Burton OT, Wise P, Zhang YQ, Hobson SA, Garcia Lloret M, et al. A microbiota signature associated with experimental food allergy promotes allergic sensitization and anaphylaxis. *J Allergy Clin Immunol* 2013;131:201–12.
- Yoshida M, Claypool SM, Wagner JS, Mizoguchi E, Mizoguchi A, Roopenian DC, et al. Human neonatal Fc receptor mediates transport of IgG into luminal secretions for delivery of antigens to mucosal dendritic cells. *Immunity* 2004;20:769–83.

## REFERENCES

- Whitman WB, Coleman DC, Wiebe WJ. Prokaryotes: the unseen majority. *Proc Natl Acad Sci U S A* 1998;95:6578–83.
- Williams IR. CCR6 and CCL20: partners in intestinal immunity and lymphorganogenesis. *Ann N Y Acad Sci* 2006;1072:52–61.
- Forster R, Pabst O, Bernhardt G. Homeostatic chemokines in development, plasticity, and functional organization of the intestinal immune system. *Semin Immunol* 2008;20:171–80.
- Nochi T, Denton PW, Wahl A, Garcia JV. Cryptopatches are essential for the development of human GALT. *Cell Rep* 2013;3:1874–84.
- Lorenz RG, Chaplin DD, McDonald KG, McDonough JS, Newberry RD. Isolated lymphoid follicle formation is inducible and dependent upon lymphotoxin-sufficient B lymphocytes, lymphotoxin beta receptor, and TNF receptor I function. *J Immunol* 2003;170:5475–82.
- Bouskra D, Brezillon C, Berard M, Werts C, Varona R, Boneca IG, et al. Lymphoid tissue genesis induced by commensals through NOD1 regulates intestinal homeostasis. *Nature* 2008;456:507–10.
- Walker WA, Isselbacher KJ. Uptake and transport of macromolecules by the intestine. Possible role in clinical disorders. *Gastroenterology* 1974;67:531–50.
- Warshaw AL, Walker WA, Isselbacher KJ. Protein uptake by the intestine: evidence for absorption of intact macromolecules. *Gastroenterology* 1974;66:987–92.
- McDole JR, Wheeler LW, McDonald KG, Wang B, Konjufca V, Knoop KA, et al. Goblet cells deliver luminal antigen to CD103+ dendritic cells in the small intestine. *Nature* 2012;483:345–9.
- Frey A, Giannasca KT, Weltzin R, Giannasca PJ, Reggio H, Lencer WI, et al. Role of the glycocalyx in regulating access of microparticles to apical plasma membranes of intestinal epithelial cells: implications for microbial attachment and oral vaccine targeting. *J Exp Med* 1996;184:1045–59.
- Wolf JL, Bye WA. The membranous epithelial (M) cell and the mucosal immune system. *Annu Rev Med* 1984;35:95–112.
- Rescigno M, Urbano M, Valzasina B, Francolini M, Rotta G, Bonasio R, et al. Dendritic cells express tight junction proteins and penetrate gut epithelial monolayers to sample bacteria. *Nat Immunol* 2001;2:361–7.
- Niess JH, Brand S, Gu X, Landsman L, Jung S, McCormick BA, et al. CX3CR1-mediated dendritic cell access to the intestinal lumen and bacterial clearance. *Science* 2005;307:254–8.
- Miller JC, Brown BD, Shay T, Gautier EL, Jojic V, Cohain A, et al. Deciphering the transcriptional network of the dendritic cell lineage. *Nat Immunol* 2012;13:888–99.
- Schulz O, Jaensson E, Persson EK, Liu X, Worbs T, Agace WW, et al. Intestinal CD103+, but not CX3CR1+, antigen sampling cells migrate in lymph and serve classical dendritic cell functions. *J Exp Med* 2009;206:3101–14.
- Mazzini E, Massimiliano L, Penna G, Rescigno M. Oral tolerance can be established via gap junction transfer of fed antigens from CX3CR1(+) macrophages to CD103(+) dendritic cells. *Immunity* 2014;40:248–61.
- Bockman D, Winborn W. Light and electron microscopy of intestinal ferritin absorption: observations in sensitized and non-sensitized hamster (*Mesocricetus auratus*). *Anat Rec* 1965;155:603–22.
- Berin MC, Kiliaan AJ, Yang PC, Groot JA, Taminiau JA, Perdue MH. Rapid transepithelial antigen transport in rat jejunum: impact of sensitization and the hypersensitivity reaction. *Gastroenterology* 1997;113:856–64.
- Walker WA, Isselbacher KJ, Bloch KJ. Intestinal uptake of macromolecules. II. Effect of parenteral immunization. *J Immunol* 1973;111:221–6.
- Chen Y, Inobe J, Weiner HL. Induction of oral tolerance to myelin basic protein in CD8-depleted mice: both CD4+ and CD8+ cells mediate active suppression. *J Immunol* 1995;155:910–16.
- Garside P, Steel M, Liew FY, Mowat AM. CD4+ but not CD8+ T cells are required for the induction of oral tolerance. *Int Immunol* 1995;7:501–4.
- Kraus TA, Toy L, Chan L, Childs J, Mayer L. Failure to induce oral tolerance to a soluble protein in patients with inflammatory bowel disease. *Gastroenterology* 2004;126:1771–8.
- Husby S, Mestecky J, Moldoveanu Z, Holland S, Elson CO. Oral tolerance in humans. T cell but not B cell tolerance after antigen feeding. *J Immunol* 1994;152:4663–70.
- Arnaboldi PM, Roth-Walter F, Mayer L. Suppression of Th1 and Th17, but not Th2, responses in a CD8(+) T cell-mediated model of oral tolerance. *Mucosal Immunol* 2009;2:427–38.
- Chen Y, Kuchroo VK, Inobe J, Hafler DA, Weiner HL. Regulatory T cell clones induced by oral tolerance: suppression of autoimmune encephalomyelitis. *Science* 1994;265:1237–40.
- Mucida D, Kutchukhidze N, Erazo A, Russo M, Lafaille JJ, Curotto de Lafaille MA. Oral tolerance in the absence of naturally occurring T<sub>REGS</sub>. *J Clin Invest* 2005;115:1923–33.
- Neurath MF, Fuss I, Kelsall BL, Presky DH, Waegell W, Strober W. Experimental granulomatous colitis in mice is abrogated by induction of TGF-beta-mediated oral tolerance. *J Exp Med* 1996;183:2605–16.
- Dubois B, Chapat L, Goubier A, Papiernik M, Nicolas JF, Kaiserlian D. Innate CD4+CD25+ regulatory T cells are required for oral tolerance and inhibition of CD8+ T cells mediating skin inflammation. *Blood* 2003;102:3295–301.
- Hadis U, Wahl B, Schulz O, Hardtke-Wolenski M, Schippers A, Wagner N, et al. Intestinal tolerance requires gut homing and expansion of FoxP3+ regulatory T cells in the lamina propria. *Immunity* 2011;34:237–46.
- Groux H, O'Garra A, Bigler M, Rouleau M, Antonenko S, de Vries JE, et al. A CD4+ T-cell subset inhibits antigen-specific T-cell responses and prevents colitis. *Nature* 1997;389:737–42.
- Viney JL, Mowat AM, O'Malley JM, Williamson E, Fanger NA. Expanding dendritic cells in vivo enhances the induction of oral tolerance. *J Immunol* 1998;160:5815–25.
- Williamson E, Westrich GM, Viney JL. Modulating dendritic cells to optimize mucosal immunization protocols. *J Immunol* 1999;163:3668–75.
- Bogunovic M, Ginhoux F, Helft J, Shang L, Hashimoto D, Greter M, et al. Origin of the lamina propria dendritic cell network. *Immunity* 2009;31:513–25.
- Worbs T, Bode U, Yan S, Hoffmann MW, Hintzen G, Bernhardt G, et al. Oral tolerance originates in the intestinal immune system and relies on antigen carriage by dendritic cells. *J Exp Med* 2006;203:519–27.
- Jaensson E, Uronen-Hansson H, Pabst O, Eksteen B, Tian J, Coombes JL, et al. Small intestinal CD103+ dendritic cells display unique functional properties that are conserved between mice and humans. *J Exp Med* 2008;205:2139–49.
- Coombes JL, Siddiqui KR, Arancibia-Carcamo CV, Hall J, Sun CM, Belkaid Y, et al. A functionally specialized population of mucosal CD103+ DCs induces Foxp3+ regulatory T cells via a TGF-beta and retinoic acid-dependent mechanism. *J Exp Med* 2007;204:1757–64.
- Morha A, Chudnovskiy A, Hashimoto D, Bogunovic M, Spencer SP, Belkaid Y, et al. Microbiota-dependent crosstalk between macrophages and ILC3 promotes intestinal homeostasis. *Science* 2014;343:1249288.
- Shan M, Gentile M, Yeiser JR, Walland AC, Bornstein VU, Chen K, et al. Mucus enhances gut homeostasis and oral tolerance by delivering immunoregulatory signals. *Science* 2013;342:447–53.
- Blazquez AB, Berin MC. Gastrointestinal dendritic cells promote Th2 skewing via OX40L. *J Immunol* 2008;180:4441–50.
- Pavli P, Maxwell L, Van de Pol E, Doe F. Distribution of human colonic dendritic cells and macrophages. *Clin Exp Immunol* 1996;104:124–32.
- Smith PD, Janoff EN, Mosteller-Barnum M, Merger M, Orenstein JM, Kearney JF, et al. Isolation and purification of CD14-negative mucosal macrophages from normal human small intestine. *J Immunol Methods* 1997;202:1–11.
- Smythies LE, Sellers M, Clements RH, Mosteller-Barnum M, Meng G, Benjamin WH, et al. Human intestinal macrophages display profound inflammatory anergy despite avid phagocytic and bacteriocidal activity. *J Clin Invest* 2005;115:66–75.
- Denning TL, Wang YC, Patel SR, Williams IR, Pulendran B. Lamina propria macrophages and dendritic cells differentially induce regulatory and interleukin 17-producing T cell responses. *Nat Immunol* 2007;8:1086–94.
- Kuhn R, Lohler J, Rennick D, Rajewsky K, Muller W. Interleukin-10-deficient mice develop chronic enterocolitis. *Cell* 1993;75:263–74.
- Zigmond E, Bernshtein B, Friedlander G, Walker CR, Yona S, Kim KW, et al. Macrophage-restricted interleukin-10 receptor deficiency, but not IL-10 deficiency, causes severe spontaneous colitis. *Immunity* 2014;40:720–33.
- Mora JR, Iwata M, Eksteen B, Song SY, Junt T, Senman B, et al. Generation of gut-homing IgA-secreting B cells by intestinal dendritic cells. *Science* 2006;314:1157–60.
- Johansson-Lindbom B, Svensson M, Wurbel MA, Malissen B, Marquez G, Agace W. Selective generation of gut tropic T cells in gut-associated lymphoid tissue (GALT): requirement for GALT dendritic cells and adjuvant. *J Exp Med* 2003;198:963–9.
- Kunkel EJ, Butcher EC. Chemokines and the tissue-specific migration of lymphocytes. *Immunity* 2002;16:1–4.
- Williams MB, Butcher EC. Homing of naive and memory T lymphocyte subsets to Peyer's

- patches, lymph nodes, and spleen. *J Immunol* 1997;159:1746–52.
50. Stenstad H, Ericsson A, Johansson-Lindbom B, Svensson M, Marsal J, Mack M, et al. Gut-associated lymphoid tissue-primed CD4+ T cells display CCR9-dependent and -independent homing to the small intestine. *Blood* 2006;107:3447–54.
  51. Svensson M, Marsal J, Ericsson A, Carramolino L, Broden T, Marquez G, et al. CCL25 mediates the localization of recently activated CD8alpha-beta(+) lymphocytes to the small-intestinal mucosa. *J Clin Invest* 2002;110:1113–21.
  52. Kunkel EJ, Kim CH, Lazarus NH, Vierra MA, Soler D, Bowman EP, et al. CCR10 expression is a common feature of circulating and mucosal epithelial tissue IgA Ab-secreting cells. *J Clin Invest* 2003;111:1001–10.
  53. Pan J, Kunkel EJ, Gossler U, Lazarus N, Langdon P, Broadwell K, et al. A novel chemokine ligand for CCR10 and CCR3 expressed by epithelial cells in mucosal tissues. *J Immunol* 2000;165:2943–9.
  54. Hammerschmidt SI, Ahrendt M, Bode U, Wahl B, Kremmer E, Forster R, et al. Stromal mesenteric lymph node cells are essential for the generation of gut-homing T cells in vivo. *J Exp Med* 2008;205:2483–90.
  55. Johansson-Lindbom B, Svensson M, Pabst O, Palmqvist C, Marquez G, Forster R, et al. Functional specialization of gut CD103+ dendritic cells in the regulation of tissue-selective T cell homing. *J Exp Med* 2005;202:1063–73.
  56. Blumberg R, Powrie F. Microbiota, disease, and back to health: a metastable journey. *Sci Transl Med* 2012;4:137rv7.
  57. Kau AL, Ahern PP, Griffin NW, Goodman AL, Gordon JI. Human nutrition, the gut microbiome and the immune system. *Nature* 2011;474:327–36.
  58. Hooper LV, Wong MH, Thelin A, Hansson L, Falk PG, Gordon JI. Molecular analysis of commensal host-microbial relationships in the intestine. *Science* 2001;291:881–4.
  59. Ivanov II, Atarashi K, Manel N, Brodie EL, Shima T, Karaoz U, et al. Induction of intestinal Th17 cells by segmented filamentous bacteria. *Cell* 2009;139:485–98.
  60. Round JL, Mazmanian SK. Inducible Foxp3+ regulatory T-cell development by a commensal bacterium of the intestinal microbiota. *Proc Natl Acad Sci U S A* 2010;107:12204–9.
  61. Atarashi K, Tanoue T, Shima T, Imaoka A, Kuwahara T, Momose Y, et al. Induction of colonic regulatory T cells by indigenous *Clostridium* species. *Science* 2011;331:337–41.
  62. Cahenzli J, Koller Y, Wyss M, Geuking MB, McCoy KD. Intestinal microbial diversity during early-life colonization shapes long-term IgE levels. *Cell Host Microbe* 2013;14:559–70.
  63. Slack E, Hapfelmeier S, Stecher B, Velykoredko Y, Stoel M, Lawson MA, et al. Innate and adaptive immunity cooperate flexibly to maintain host-microbiota mutualism. *Science* 2009;325:617–20.
  64. Stefka AT, Feehley T, Tripathi P, Qiu J, McCoy K, Mazmanian SK, et al. Commensal bacteria protect against food allergen sensitization. *Proc Natl Acad Sci U S A* 2014;111:13145–50.
  65. Round JL, Lee SM, Li J, Tran G, Jabri B, Chatila TA, et al. The Toll-like receptor 2 pathway establishes colonization by a commensal of the human microbiota. *Science* 2011;332:974–7.
  66. Bashir ME, Louie S, Shi HN, Nagler-Anderson C. Toll-like receptor 4 signaling by intestinal microbes influences susceptibility to food allergy. *J Immunol* 2004;172:6978–87.
  67. Hall JA, Bouladoux N, Sun CM, Wohlfert EA, Blank RB, Zhu Q, et al. Commensal DNA limits regulatory T cell conversion and is a natural adjuvant of intestinal immune responses. *Immunity* 2008;29:637–49.
  68. Arpaia N, Campbell C, Fan X, Dikiy S, van der Veeken J, deRoos P, et al. Metabolites produced by commensal bacteria promote peripheral regulatory T-cell generation. *Nature* 2013;504:451–5.
  69. Noval Rivas M, Burton OT, Wise P, Zhang YQ, Hobson SA, Garcia Lloret M, et al. A microbiota signature associated with experimental food allergy promotes allergic sensitization and anaphylaxis. *J Allergy Clin Immunol* 2013;131:201–12.
  70. Turnbaugh PJ, Ridaura VK, Faith JJ, Rey FE, Knight R, Gordon JI. The effect of diet on the human gut microbiome: a metagenomic analysis in humanized gnotobiotic mice. *Sci Transl Med* 2009;1:6ra14.
  71. DePaolo RW, Abadie V, Tang F, Fehlner-Peach H, Hall JA, Wang W, et al. Co-adjuvant effects of retinoic acid and IL-15 induce inflammatory immunity to dietary antigens. *Nature* 2011;471:220–4.
  72. Chang JH, Cha HR, Lee DS, Seo KY, Kweon MN. 1, 25-Dihydroxyvitamin D3 inhibits the differentiation and migration of T(H)17 cells to protect against experimental autoimmune encephalomyelitis. *PLoS ONE* 2010;5:e12925.
  73. Yu S, Bruce D, Froicu M, Weaver V, Cantorna MT. Failure of T cell homing, reduced CD4/CD8alphaalpha intraepithelial lymphocytes, and inflammation in the gut of vitamin D receptor KO mice. *Proc Natl Acad Sci U S A* 2008;105:20834–9.
  74. Quintana FJ, Basso AS, Iglesias AH, Korn T, Farez MF, Bettelli E, et al. Control of T(reg) and T(H)17 cell differentiation by the aryl hydrocarbon receptor. *Nature* 2008;453:65–71.
  75. Schulz VJ, Smit JJ, Willemsen KJ, Fiechter D, Hassing I, Bleumink R, et al. Activation of the aryl hydrocarbon receptor suppresses sensitization in a mouse peanut allergy model. *Toxicol Sci* 2011;123:491–500.
  76. Upadhyay V, Poroyko V, Kim TJ, Devkota S, Fu S, Liu D, et al. Lymphotoxin regulates commensal responses to enable diet-induced obesity. *Nat Immunol* 2012;13:947–53.
  77. Feng N, Jaimes MC, Lazarus NH, Monak D, Zhang C, Butcher EC, et al. Redundant role of chemokines CCL25/TECK and CCL28/MEC in IgA+ plasmablast recruitment to the intestinal lamina propria after rotavirus infection. *J Immunol* 2006;176:5749–59.
  78. Mora JR, von Andrian UH. Differentiation and homing of IgA-secreting cells. *Mucosal Immunol* 2008;1:96–109.
  79. Mantis NJ, Cheung MC, Chintalacharuvu KR, Rey J, Corthesy B, Neutra MR. Selective adherence of IgA to murine Peyer's patch M cells: evidence for a novel IgA receptor. *J Immunol* 2002;169:1844–51.
  80. Rochereau N, Drocourt D, Perouzel E, Pavot V, Redelinguys P, Brown GD, et al. Dectin-1 is essential for reverse transcytosis of glycosylated SIgA-antigen complexes by intestinal M cells. *PLoS Biol* 2013;11:e1001658.
  81. Corthesy B. Roundtrip ticket for secretory IgA: role in mucosal homeostasis? *J Immunol* 2007;178:27–32.
  82. Israel EJ, Taylor S, Wu Z, Mizoguchi E, Blumberg RS, Bhan A, et al. Expression of the neonatal Fc receptor, FcRn, on human intestinal epithelial cells. *Immunology* 1997;92:69–74.
  83. Dickinson BL, Badizadegan K, Wu Z, Ahouse JC, Zhu X, Simister NE, et al. Bidirectional FcRn-dependent IgG transport in a polarized human intestinal epithelial cell line. *J Clin Invest* 1999;104:903–11.
  84. Yoshida M, Claypool SM, Wagner JS, Mizoguchi E, Mizoguchi A, Roopenian DC, et al. Human neonatal Fc receptor mediates transport of IgG into luminal secretions for delivery of antigens to mucosal dendritic cells. *Immunity* 2004;20:769–83.
  85. Yoshida M, Kobayashi K, Kuo TT, Bry L, Glickman JN, Claypool SM, et al. Neonatal Fc receptor for IgG regulates mucosal immune responses to luminal bacteria. *J Clin Invest* 2006;116:2142–51.
  86. Mosconi E, Rekima A, Seitz-Polski B, Kanda A, Fleury S, Tissandie E, et al. Breast milk immune complexes are potent inducers of oral tolerance in neonates and prevent asthma development. *Mucosal Immunol* 2010;3:461–74.
  87. Brown WR, Borthistle BK, Chen ST. Immunoglobulin E (IgE) and IgE-containing cells in human gastrointestinal fluids and tissues. *Clin Exp Immunol* 1975;20:227–37.
  88. Belut D, Moneret-Vautrin DA, Nicolas JP, Grilliat JP. IgE levels in intestinal juice. *Dig Dis Sci* 1980;25:323–32.
  89. Li H, Nowak-Wegrzyn A, Charlop-Powers Z, Shreffler W, Chehade M, Thomas S, et al. Transcytosis of IgE-antigen complexes by CD23a in human intestinal epithelial cells and its role in food allergy. *Gastroenterology* 2006;131:47–58.
  90. Kaiserlian D, Lachaux A, Grosjean I, Graber P, Bonnefoy JY. Intestinal epithelial cells express the CD23/Fc epsilon RII molecule: enhanced expression in enteropathies. *Immunology* 1993;80:90–5.
  91. Palaniyandi S, Tomei E, Li Z, Conrad DH, Zhu X. CD23-dependent transcytosis of IgE and immune complex across the polarized human respiratory epithelial cells. *J Immunol* 2011;186:3484–96.

# Evaluation of Food Allergy

S. ALLAN BOCK | HUGH A. SAMPSON

## KEY POINTS

- A *food allergy* is an adverse health effect arising from an immune response that occurs reproducibly on exposure to a given food, whereas a *food intolerance* is an adverse effect due to a nonimmunologic response, e.g. metabolic, pharmacologic or toxic.
- Food allergies may be 'immediate' (IgE-mediated) or 'delayed' (non-IgE-mediated) in onset and induce a variety of symptoms involving the skin, respiratory or gastrointestinal tracts and/or cardiovascular system.
- A thorough and detailed history is the most important part of the evaluation and determines which laboratory tests should be ordered, which food challenges and treatments may be required, and the education that will be needed regarding the results.
- Prick skin tests and food-specific IgE levels confirm sensitization and provide some evidence on the probability of clinical allergy, but alone are never adequate to make the diagnosis of food allergy.
- The oral food challenge remains the 'gold standard' for diagnosing food allergy.

## Introduction

It is now 40 years since the first double-blind placebo-controlled food challenges were performed and demonstrated that histories of adverse food reactions could be objectively confirmed or refuted.<sup>1</sup> Recently, new diagnostic tools have become available that may decrease the number of challenges required for accurate diagnosis and management. In addition, treatments for food allergy are being developed and studied, and while they are not quite ready for clinical use, these developments are exciting and offer hope that one day a treatment will end the impact of food allergy on patients' quality of life.<sup>2</sup>

The definitions of terms in this discussion are derived from and consistent with the 2010 Guidelines for the Diagnosis and Management of Food Allergy in the United States: summary of the NIAID Sponsored Expert Panel Report, and the recent Practice Parameter Update.<sup>3,4</sup>

'*Food allergy* is defined as an adverse health effect arising from a specific immune response that occurs reproducibly on exposure to a given food.'<sup>3</sup> These immune responses may be IgE-mediated, non-IgE-mediated or an apparent mixture of multiple mechanisms. The term *food intolerance* is used to designate a nonimmune mediated reaction that may include metabolic, pharmacologic or toxic mechanisms. Another

important term is *sensitization*, which indicates that individuals may have demonstrable IgE or other antibodies or antigen-reactive cells in the absence of clinical symptoms. An immune-mediated food allergy requires both the presence of sensitization and clinical responsiveness when the food is ingested.

## Prevalence

Current literature suggests that food allergy may affect up to 10% of the population, but probably not more than that percentage. Studies of prevalence have certain limitations, making them difficult to compare. In children, a 2009–2010 study estimated that 8% of the study population of children have food allergy.<sup>5</sup> In a Canadian study,<sup>6</sup> after adjusting for improbable reports of food allergy, it was estimated that 6.7% of the overall population, 7.1% of children and 6.6% of adults, had food allergy. Since these conclusions were based upon self-reporting, it is clear that they are estimates at best. McGowan et al<sup>7</sup> used the National Health and Nutrition Examination Study (NHANES) 2007–2010 data based upon specific food allergen IgE measurements and a specific set of definitions to arrive at an estimated prevalence of food allergy among children of 6.5%.

## IgE-Mediated Symptoms (Box 41-1)

### CUTANEOUS SYMPTOMS

Food allergy-induced skin symptoms generally fall into two main categories: atopic dermatitis and urticaria. Urticaria typically begins promptly after the ingestion of a known food allergen, is usually diagnosed early and the culprit food determined. Chronic urticaria is rarely due to a food allergen. Rarely, food additives have been reported to cause chronic urticaria in adults, but there are no systematically confirmed reports in children.

Atopic dermatitis has been shown to be exacerbated by food allergies in numerous, carefully controlled studies using double-blind, placebo-controlled food challenges. Food allergic reactions may trigger an eczematous rash in 30–40% of children with moderate-to-severe atopic dermatitis. In some situations, the onset of symptoms is subtle and somewhat delayed, with irritability and then itching being the first symptoms to appear, followed by erythema and/or urticaria preceding the more typical erythema and morbilliform eruption that may be most prominent the day after the offending food is consumed. There does not appear to be a single pattern of presentation, but careful observations by families can often make the connection, especially when parents are instructed on the typical presentation. The mechanisms of these reactions are considered in detail in Chapter 47.<sup>8–10</sup>



### BOX 41-1 DIFFERENTIAL DIAGNOSIS OF ADVERSE REACTIONS TO FOODS: IMMUNE

#### IgE-MEDIATED

- Immediate (gastrointestinal, respiratory, cutaneous, ocular, cardiovascular, anaphylactic)
- Immediate and late-phase (atopic dermatitis, allergic gastrointestinal disorders)
- Oral allergy syndrome or pollen-food allergy syndrome

#### NON-IgE IMMUNE-MEDIATED

- Celiac disease, dermatitis herpetiformis
- Food protein-induced gastrointestinal illnesses
  - Food protein-induced enterocolitis
  - Eosinophilic esophagitis, gastroenteritis (allergic)
  - Allergic colitis/proctocolitis
  - Food protein-induced enteropathy (milk, soy, others)
- Food-induced pulmonary hemosiderosis (Heiner's syndrome)

#### NON-IMMUNE-MEDIATED

- Toxic reactions
- Toxic reactions (food poisoning, e.g. scombroid fish poisoning)
- Non-toxic reactions
- Intolerances
  - Carbohydrate malabsorption (e.g. lactase deficiency, fructose deficiency, sucrase-isomaltase deficiency)
- Psychological reactions (strongly held beliefs)

## RESPIRATORY SYMPTOMS

Respiratory symptoms of a food allergic reaction include those in the upper respiratory tract – sneezing, nasal pruritus, rhinorrhea and congestion, and periocular pruritus and tearing. In the lower respiratory tract, symptoms and signs include stridor, hoarse voice, cough, dyspnea and wheezing. It is important to note that a hacking staccato cough may be a sign of impending laryngeal obstruction without other symptoms and may lead to abrupt airway closure. Asthma is infrequently the sole manifestation of an allergic reaction to food. However when a patient with asthma has symptoms that are not responding in the usual fashion to treatment, a food reaction should be considered and the treatment approach altered to include injected epinephrine. Food allergy in individuals with asthma may predispose them to more severe episodes and may be a risk factor for more severe and fatal asthma.<sup>11–19</sup>

## GASTROINTESTINAL SYMPTOMS

Immediate-onset gastrointestinal symptoms include nausea, abdominal pain and cramps, vomiting and diarrhea. Nausea and vomiting are often immediate – while the food is being consumed, raising the suspicion of food allergy, especially in an individual with a known food allergy. In individuals without known food allergy, these symptoms should raise the suspicion of a food allergy as often as ‘food poisoning’ is suspected. It should be noted that the gastrointestinal symptoms may not be accompanied by skin manifestations. Rapid resolution of gastrointestinal symptoms and return of appetite are frequently noted after a gastrointestinal food reaction. Diarrhea may occur immediately or be delayed for a few hours.

The issue of colic as a gastrointestinal food allergic reaction in infants remains controversial. With newer feeding guidelines

suggesting that delaying food introduction may increase food allergy, it is often difficult to determine whether or not to try elimination diets.<sup>20</sup> However, when infants and families are under significant distress, a brief trial of dietary elimination may be warranted.<sup>21–25</sup>

### *Pollen/Food Allergy Syndrome* (also see Chapter 46)

Pollen-food allergy syndrome (oral allergy syndrome) is a common disorder in which oral symptoms, itching of the throat and occasionally mild oral edema occur immediately upon the ingestion of certain foods, most commonly raw fruits and vegetables, but also certain nuts, e.g. hazelnuts and peanuts can trigger these symptoms. These complaints are due to specific IgE antibodies directed to aeroallergens that cross-react with certain food proteins. It is often useful to perform skin tests with fresh fruits and vegetables to confirm the diagnosis, and component protein testing for hazelnut (Cor a 9 and 14) and peanut (Ara h 8) will identify IgE to the birch pollen cross-reactive protein, Bet v 1. This constellation of symptoms is often present in children, but it is often unrecognized unless patients with pollen allergy (and/or their parents) are specifically queried about the presence of oral symptoms with certain foods.<sup>26–29</sup>

### *Chronic Constipation*

A few controlled trials suggest that this is worth considering in youngsters having persistent constipation issues, but this remains controversial.<sup>30</sup>

### *Eosinophilic Esophagitis*

(see Chapter 45 and below)

Many children with eosinophilic esophagitis (EoE) have an IgE-mediated food allergy and atopy, but the underlying immunopathogenic mechanism of EoE is not IgE-mediated and routine allergy tests are generally not helpful in identifying foods provoking symptoms.

## CARDIOVASCULAR SYMPTOMS

Allergic reactions to foods that involve the cardiovascular system in children usually appear as respiratory compromise first and then progress to a drop in blood pressure and shock, as contrasted with adults who may have the sudden onset of cardiovascular symptoms before any other symptoms occur.

## ANAPHYLAXIS (see also Chapter 58)

The working definition of anaphylaxis is ‘a serious allergic reaction that is rapid in onset and may cause death.’<sup>31</sup> The clinical criteria for diagnosing anaphylaxis are outlined in Chapter 58. Acceptance and use of these criteria should aid emergency responders in the rapid identification of anaphylaxis and prompt the institution of resuscitative measures, as validated in recent studies.<sup>32,33</sup>

## Non-IgE Immune-Mediated Reactions to Food

Celiac disease is an autoimmune process that occurs when antibodies directed to gluten cross-react with epithelial cells in the gastrointestinal tract. When gluten-containing foods are

removed from the diet, the gastrointestinal lesion resolves. An associated but less common condition is dermatitis herpetiformis that is often mistaken for atopic dermatitis. Virtually all individuals with celiac disease exhibit HLA-DQ2 or DQ8 genetic haplotypes.<sup>34</sup>

The eosinophilic gastrointestinal disorders (see Chapter 45), especially EoE, appear to be increasing. In the majority of children, food allergy is a significant trigger; however, it is not IgE-mediated and therefore current diagnostic methods for detection of IgE (skin tests and specific serum antibody measurements) are generally not helpful. A careful and detailed history may be the most important means of raising suspicion of the disease and prompting referral of the youngster for endoscopy. A pattern of seasonal exacerbation in some individuals raises the possibility of swallowed aeroallergens as triggers. It is often difficult to monitor the effectiveness of food elimination diets because there are no noninvasive tests to examine the esophagus for a response.

Another gastrointestinal syndrome that is immunologically mediated is food protein-induced enterocolitis syndrome (FPIES; see also Chapter 44). A careful history elicits a pattern of repetitive vomiting that is delayed by about 2 hours after the ingestion of culprit foods. Characteristics of FPIES that distinguish it from IgE-mediated gastrointestinal reactions are the delayed onset of symptoms, the lack of immediate recovery after the vomiting, and the continuous pattern of vomiting, pallor and hypotension in about 15% of cases. There is a helpful website for both parents and providers (fpies.org).<sup>35,36</sup> Food protein-induced proctocolitis is characterized by gross or occult blood in the stools with an otherwise healthy appearing infant (see Chapter 44).

## Non-Immunologic Reactions

### TOXIC REACTIONS

A number of toxic reactions have been described that could be confused with allergic reactions to food. Food poisoning due to bacterial contamination commonly provokes nausea, abdominal pain and often profuse diarrhea. Scombroid fish poisoning, due to histamine in poorly prepared histidine-containing fish, is less common and can more easily mimic an allergic reaction, including triggering skin changes that are not caused by bacterial food poisoning. These skin changes may include flushing, urticaria and angioedema. Respiratory symptoms may occur due to the large amount of histamine present.

### NON-TOXIC REACTIONS

Auriculotemporal syndrome (Frey's syndrome) is triggered when foods that increase salivation cause a flushing reflex through the auriculotemporal branch of the trigeminal nerve resulting in a 'strap-like' rash on both sides of the face.<sup>37</sup> Gustatory rhinitis triggers rhinorrhea due to the ingestion of spicy foods.<sup>38</sup>

Lactose intolerance due to lactase deficiency is the most common carbohydrate malabsorption condition. When there is insufficient lactase in the intestinal mucosa, diarrhea and bloating ensue, and the condition may be confused with milk allergy. Depending upon the degree of lactase deficiency, some patients may tolerate small quantities of milk products without symptoms. Chronic diarrhea in young children may be due to carbohydrate malabsorption caused by fructose in fruit and

especially fruit juice. The diarrhea, which often has an acrid smell, may be accompanied by a scalded skin appearance in the perianal and diaper area in the youngest children.

## Psychological Reactions

Some parents harbor strongly held beliefs about specific foods that trigger various symptoms in their children, including behavioral changes. These beliefs are usually imposed on children by their parents and may lead to food aversions. Clinicians must be vigilant to ensure these beliefs and dietary restrictions do not lead to malnutrition or deficiency in specific nutrients. Occasionally, Münchausen syndrome by proxy must be considered, most often related to behavioral changes or other subjective symptoms.<sup>39</sup>

## Evaluation

### HISTORY

A thorough and detailed history is the most important part of the evaluation and will determine which specific laboratory tests to order, which food challenges and treatments may be required, and the education that will be needed regarding the results and avoidance of food triggers. The details to be ascertained include a detailed description of the following: symptoms that have been observed including the sequence of those symptoms; timing from onset of symptoms to their resolution; number of events that have occurred for each suspected food; possible ingestion of the food without symptoms; quantity of food eliciting symptoms, including the least amount (threshold) that has triggered symptoms if there has been more than one event; and associated factors such as exercise (in food-dependent exercise-induced anaphylaxis), medication (especially antireflux medication) and alcohol ingestion accompanying the suspected food.<sup>2-4</sup>

A history of anaphylaxis or a severe reaction increases the need for accurate details that include getting the ingredients of a meal from the facility (restaurant, home or school) where the reaction occurred. This may lead to suspicions about less obvious culprits, especially spices. Emergency department records may be helpful. It is also important in situations where wheezing has been part of the reaction, to inquire if the asthma symptoms responded in the usual manner for that individual. If not then a food might have been the trigger.

### PHYSICAL EXAMINATION

A complete physical examination should be done in children with a history of a food allergic reaction; however, the exam is usually normal unless the reaction is occurring acutely. The major exception is atopic dermatitis, which is a chronic condition that may exacerbate during the acute reaction. Other stigmata to observe include a possible abnormal abdominal examination, signs of malnutrition, or significant failure to thrive in young children placed on a restricted diet.

### LABORATORY STUDIES

#### Skin Testing

Skin testing by the prick/puncture technique is an easy to perform, cost-effective method for identifying sensitization to

a food and for determining the probability that a food challenge is likely to be helpful.<sup>40</sup> Food allergens eliciting wheal diameters of at least 3 mm or larger than the negative control are considered positive test results. Negative skin tests have a high negative predictive accuracy, thus usually excluding food allergy to common foods. The negative predictive accuracy for children younger than 3 or 4 years of age tends to be lower than for older children.<sup>2-4</sup>

Food extracts that elicit a positive result in the absence of a strong history of clinical reactivity typically have a positive predictive accuracy of less than 50% and cannot be considered diagnostic of symptomatic food allergy. Some studies suggest that larger skin tests ( $\geq 8$ -mm wheals for some foods) correlate better with symptomatic food allergy, but there is no correlation between skin test size and severity of reactions.<sup>41</sup> If there is a history of a convincing allergic reaction to a food and the skin test is positive, the test may be viewed as diagnostic. There have been rare reports of adverse reactions to intracutaneous skin tests.<sup>42</sup>

Skin test outcomes can be variable depending on a few factors: reagents and devices used for testing, experience of the testing personnel and the interpretation of the test results. A strongly positive history incriminating a specific food in the face of a negative skin test must be evaluated further, e.g. food-specific serum IgE determination and/or physician-supervised oral food challenge.

Skin tests must be selected judiciously based upon the history rather than performing 'panels of food skin tests'. Selection of numerous foods to be eliminated from the diet based on large numbers of poorly selected skin tests may lead to diets that are difficult for families to follow and may eliminate foods that are clearly tolerated, making adherence to the diet poor.<sup>43</sup> In rare instances these diets can be so strict as to be nutritionally inadequate.<sup>39,44</sup>

Commercial skin test extracts vary considerably in allergen content. It is often very useful to use fresh fruits and vegetables for skin testing by the technique referred to as 'prick to prick'. In this technique the fresh food is 'pricked with the skin test device and then the skin is pricked immediately'. The results of these tests are very helpful when positive, but less so when negative.<sup>45-47</sup>

Limitations of skin testing include a number of variables: (1) commercially prepared extracts often lack labile proteins responsible for IgE-mediated sensitization to most fruits and vegetables (as noted above); (2) skin testing on skin surfaces that have been treated with topical steroids may induce smaller wheals than those measured on untreated skin; (3) negative prick skin tests with commercial extracts that do not confirm convincing histories of food reactions should be repeated with the fresh food before concluding that IgE is absent; and (4) long-term, high-dose systemic steroid therapy may reduce allergen wheal size.

Intradermal skin testing for food is not recommended because of its high false positive rate and its occasional association with systemic reactions. However, intradermal skin tests have been found to be useful in reactions to beef, pork and lamb due to reactivity to the meat proteins and galactose- $\alpha$ -1, 3-galactose.<sup>48</sup>

### In Vitro Testing

Numerous studies have shown that specific serum antibody levels correlate well with the outcome of oral food challenges, especially for peanut, egg, milk and tree nuts, but there is less

information on fish, shellfish and a few other foods. As with skin testing, detectable antibody in an immunoassay gives probability information on the likelihood of a reaction to a suspected food, but the history and food challenge remain crucial. Two early studies established 'cut-off values' giving 95% decision points, which suggested that values exceeding these levels obviated the need for a food challenge.<sup>49,50</sup> Since then, numerous other studies have been performed in various populations and with children of various ages.<sup>40,51-55</sup> Recent studies suggest that longitudinal monitoring of specific serum antibody levels may be useful in deciding when a child may have outgrown a particular food allergy and when a challenge is likely to be helpful in identifying the resolution of a food allergy. The rate of fall of specific serum antibody levels may be a useful predictor of the resolution of a food allergy. These decision points have also been used as 'cut-off' values to determine a reasonable level for doing food challenges based on the likelihood of resolution of a food allergy.<sup>56</sup> Two recent studies have formulated predictive curves for the probability of resolution of egg and milk allergy in young children.<sup>57,58</sup>

In vitro measurements are preferred in a number of situations: (1) patients with extensive dermatographism; (2) patients with extensive skin disease (atopic dermatitis or urticaria); (3) patients who cannot discontinue antihistamines; and more recently (4) use by nonspecialists who do not perform skin testing to evaluate children for potential food allergy.

There is no consensus on whether skin tests or specific serum antibody levels are most sensitive. However, at least one study has found that prick/puncture skin tests and immunoassays have similar sensitivities and specificities when compared with double-blind, placebo-controlled food challenges.<sup>59</sup> At present, most allergists use the two tests together to decide whether or not to do challenges (see below), and the probability of the challenge being positive for a particular food (Table 41-1).

A new and potentially important advance in in vitro diagnosis is the availability of component-resolved diagnostics for evaluation of food allergy (see Chapter 18). However, at this time only a limited number of food component proteins have been demonstrated to correlate well with clinical reactivity to food, e.g. peanut (Ara h 1, 2, 3, 6 and 8) and hazelnut (Cor a 1, 9 and 14).<sup>60-63</sup> As with other diagnostic tests, care needs to be taken when using component measurements to ensure that patients are not told a food is safe when it is not.<sup>64</sup>

TABLE 41-1 Predictive Value of Food-Specific IgE

Allergen	Decision Point (kU <sub>A</sub> /L)	Rechallenge Value (kU <sub>A</sub> /L)
Egg	$\geq 7.0$	$\leq 1.5$
$\leq 2$ years old	$\geq 2.0$	
Milk	$\geq 15.0$	$\leq 7.0$
$\leq 2$ years old	$\geq 5.0$	
Peanut	$\geq 14.0$	$\leq 5.0$
Fish	$\geq 20.0$	
Tree nuts	$\geq 15.0$	$< 2$

Adapted from Sampson HA.<sup>50</sup>

Note: Patients with food-specific IgE values less than the listed diagnostic values may experience an allergic reaction following challenge. Unless history strongly suggests tolerance, a physician-supervised food challenge should be performed to determine if the child can ingest the food safely.

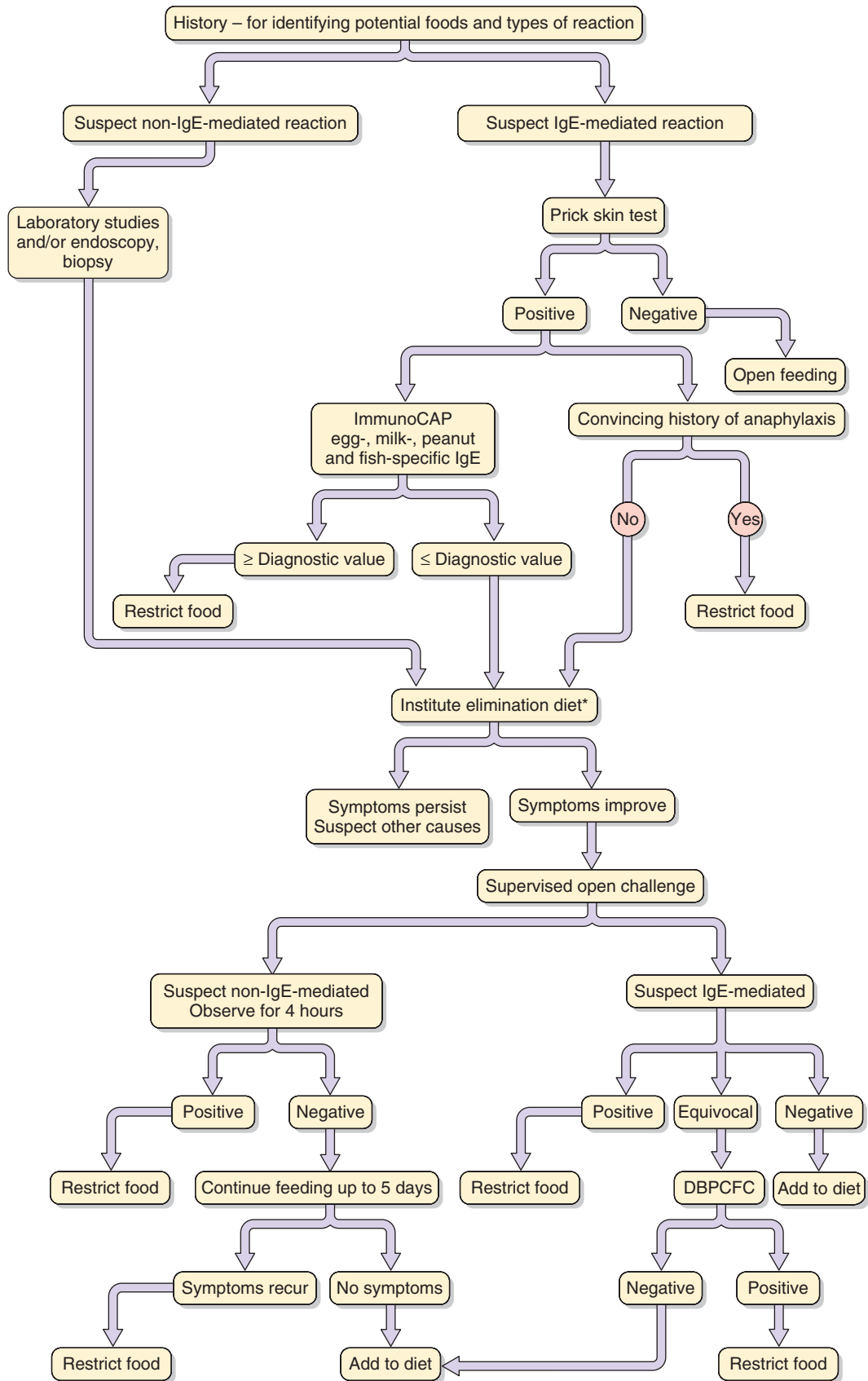

\* Up to 2 weeks for IgE-mediated reactions; up to 8 weeks for non-IgE-mediated food hypersensitivity.

Figure 41-1 Algorithm diagnosing food hypersensitivity. IgE – Immunoglobulin E, DBPCFC, – double-blind, placebo-controlled food challenge.



It has also been found that patients with antibodies to sequential (linear) epitopes in egg and milk, as compared to conformational epitopes to these foods, are more likely to exhibit persistent food allergy. Extensive heating (baking) of milk and egg changes conformational epitopes that are recognized by the majority of youngsters, allowing them to tolerate baked milk- and egg-containing products. Peptide microarray technology is characterizing patient heterogeneity and may more accurately predict clinically significant food allergy as opposed to just allergen sensitization.<sup>65–78</sup>

Serum IgG levels to foods have not been found to have clinical utility. All individuals with a normal immune system will produce some IgG antibodies to many food proteins.<sup>79</sup>

'Atopy patch tests' have not been found to be consistently useful for detection of clinically significant food allergy.<sup>3,4,80</sup>

## FOOD CHALLENGES

The double-blind, placebo-controlled food challenge (DBPCFC) is the gold standard for precise diagnosis of allergic reactions to foods, and has provided a standard by which to evaluate other tests. All food challenges are designed to confirm or refute patient histories with the double-blind technique being the most precise, but also the most cumbersome. Recently, an attempt has been made to establish standard protocols. Challenges that use both active and placebo foods may generally be given on two separate days or one set (active or placebo) in the morning and the other set (placebo or active) after lunch.<sup>81–91</sup>

Unless a specific protocol is being used as part of a study, the quantity of food used in the challenge and the interval between portions is determined by the history elicited from the patient/parents. One approach is to start with an amount about one half of that thought to be lower than the amount previously triggering symptoms. Another approach is to make up the entire challenge and then give a certain percentage at the prescribed intervals. The time between portions should allow for the possibility of symptoms to occur before the next portion is

ingested (as suggested by the history). When the challenge is negative or passed, up to approximately 8–10 g of dried foods or 60–100 g of wet food in a single portion, the challenge ends. A negative or passed challenge is not considered negative until the food is actually in the patient's diet in usual and customary portions on multiple occasions.

Single blind food challenges are useful in situations in which an objective result from the patient is important, such as a history of subjective symptoms, but it is less important for the individual providing the challenge to be blinded. The protocols may be the same or similar to those used for DBPCFC. This procedure may be useful when an open challenge (see below) is not likely to be accurate but the rigor of DBPCFC is not needed.

In the clinical setting, open food challenges are very useful for refuting food allergy histories and may be useful when the challenge is positive with objective symptoms that recapitulate symptoms that have been reported in the history. Open challenges are also useful for determining if there are foods that have never been ingested but for which there is a positive diagnostic test with low likelihood. For example a youngster with egg allergy who has never ingested peanut but who has a small positive skin test or a low level of specific antibody may be challenged under observation using an open challenge.

## SUMMARY OF APPROACH

Figure 41-1 outlines a summary of the approach for the evaluation of children with a history of adverse reactions to food. A detailed history is followed by selection of skin tests and in vitro tests to be performed. The results of these tests allow selection of foods to be challenged under observation or reintroduced at home. Care must always be taken to be certain that any possible food culprit is introduced under observation.

The complete reference list can be found on the companion Expert Consult website at <http://www.expertconsult.inkling.com>.

## KEY REFERENCES

- Sicherer SH, Sampson HA. Food allergy: epidemiology, pathogenesis, diagnosis, and treatment. *J Allergy Clin Immunol* 2014;133:291–307.
- Boyce JA, Assa'ad A, Burks AW, Jones SM, Sampson HA, Wood RA, et al. Guidelines for the diagnosis and management of food allergy in the United States: report of the NIAID-sponsored expert panel. *J Allergy Clin Immunol* 2010;126:S1–58.
- Sampson HA, Aceves S, Bock SA, James J, Jones SM, Lang D, et al. Food Allergy: a practice parameter update – 2014. *J Allergy Clin Immunol* 2014;134:1016–25.
- Gupta RS, Springston EE, Warriar MR, Smith B, Kumar R, Pongracic J, et al. The prevalence, severity, and distribution of childhood food allergy in the United States. *Pediatrics* 2011;128:e9–17.
- Friedlander JL, Sheehan WJ, Baxi SN, Kopel LS, Gaffin JM, Ozonoff A, et al. Food allergy and increased asthma morbidity in a school-based inner-city asthma study. *J Allergy Clin Immunol Pract* 2013;1:479–84.
- Flesicher DM, Spergel JM, Assa'ad AH, Pongracic JA. Primary prevention of allergic disease through nutritional interventions. *J Allergy Clin Immunol Pract* 2013;1:479–84.
- Sampson HA, Munoz-Furlong A, Campbell RL, Adkinson NF, Bock SA, Branum A. Second Symposium on the definition and management of anaphylaxis: summary report – Second National Institute of Allergy and Infectious Disease/Food Allergy and Anaphylaxis Network symposium. *J Allergy Clin Immunol* 2006;117:391–7.
- Nowak R, Farrar JR, Brenner BE, Lewis L, Silverman RA, Emerman C, et al. Customizing anaphylaxis guidelines for emergency medicine. *J Emerg Med* 2013;45:299–306.
- Burks AW, Tang M, Sicherer S, Muraro A, Eigenmann PA, Ebisawa M, et al. ICON: food allergy. *J Allergy Clin Immunol* 2012;129:906–20.
- Sampson HA, van Wijk RG, Bindslev-Jensen C, Sicherer SH, Teuber SS, Burks AW, et al. Standardizing double-blind, placebo-controlled oral food challenges: American Academy of Allergy, Asthma & Immunology-European Academy of Allergy and Clinical Immunology PRACTALL consensus report. *J Allergy Clin Immunol* 2012;130:1260–74.

## REFERENCES

- May CD. Objective clinical and laboratory studies of immediate hypersensitivity reactions to food in asthmatic children. *J Allergy Clin Immunol* 1976;58:500–15.
- Sicherer SH, Sampson HA. Food allergy: epidemiology, pathogenesis, diagnosis, and treatment. *J Allergy Clin Immunol* 2014;133:291–307.
- Boyce JA, Assa'ad A, Burks AW, Jones SM, Sampson HA, Wood RA, et al. Guidelines for the diagnosis and management of food allergy in the United States: report of the NIAID-sponsored expert panel. *J Allergy Clin Immunol* 2010;126:S1–58.
- Sampson HA, Aceves S, Bock SA, James J, Jones SM, Lang D, et al. Food Allergy: a practice parameter update – 2014. *J Allergy Clin Immunol* 2014;134:1016–25.
- Gupta RS, Springston EE, Warrier MR, Smith B, Kumar R, Pongracic J, et al. The prevalence, severity, and distribution of childhood food allergy in the United States. *Pediatrics* 2011;128:e9–17.
- Soller L, Ben Shoshan M, Harrington DW, Fragapane J, Joesph L, St Pierre Y, et al. Overall prevalence of self-reported food allergy in Canada. *J Allergy Clin Immunol* 2012;130:986–8.
- McGowan EC, Keet CA. Prevalence of self-reported food allergy in the National Health and Nutrition Examination Survey (NHANES) 2007–2010. *J Allergy Clin Immunol* 2013;132:1216–19.
- Sampson HA, McCaskill CM. Food hypersensitivity and atopic dermatitis: evaluation of 113 patients. *J Pediatr* 1985;107:669–75.
- Burks AW, Mallory SB, Williams L, Shirrell MA. Atopic dermatitis: clinical relevance of food hypersensitivity reactions. *J Pediatr* 1988;113:447–51.
- Schneider AD, Tilles S, Lo P. Atopic dermatitis: a practice parameter update. *J Allergy Clin Immunol* 2013;131:295–9.
- Roberts G, Patel N, Levi-Schaffer F, Habibi P, Lack G. Food allergy as a risk factor for life-threatening asthma in childhood: a case controlled study. *J Allergy Clin Immunol* 2003;112:168–74.
- Schroeder A, Kumar R, Pongracic JA, Sullivan CL, Caruso DM, Costello J. Food allergy is associated with an increased risk of asthma. *Clin Exp Allergy* 2009;39:261–70.
- Bock SA, Munoz-Furlong A, Sampson HA. Fatalities due to anaphylactic reactions to foods. *J Allergy Clin Immunol* 2001;107:101–3.
- Bock SA, Munoz-Furlong A, Sampson HA. Further fatalities caused by anaphylactic reactions to foods, 2001–2006. *J Allergy Clin Immunol* 2007;119:1016–18.
- Pumphrey RSH, Stanworth SJ. The clinical spectrum of anaphylaxis in north-west England. *Clin Exp Allergy* 1996;26:1364–70.
- Pumphrey RS, Gowland MH. Further fatal allergic reactions to food in the United Kingdom, 199–2006. *J Allergy Clin Immunol* 2007;119:1018–19.
- Wang J, Visness CM, Sampson HA. Food allergen sensitization in inner-city children with asthma. *J Allergy Clin Immunol* 2005;115:1076–80.
- Preece K, Bhatia R, Belcher J, Patchett K, McElduff P, Collison A, et al. The fraction of exhaled nitric oxide improves prediction of clinical allergic reaction to peanut challenge in children. *Clin Exp Allergy* 2014;44:371–80.
- Friedlander JL, Sheehan WJ, Baxi SN, Kopel LS, Gaffin JM, Ozonoff A, et al. Food allergy and increased asthma morbidity in a school-based inner-city asthma study. *J Allergy Clin Immunol Pract* 2013;1:479–84.
- Flesicher DM, Spergel JM, Assa'ad AH, Pongracic JA. Primary prevention of allergic disease through nutritional interventions. *J Allergy Clin Immunol Pract* 2013;1:479–84.
- Sampson HA. Infantile colic and food allergy: fact or fiction. *J Pediatr* 1989;115:583–4.
- Hill DJ, Hudson IL, Sheffield L, Shelton MJ, Menahem S, Hosking CS. A low allergen diet is a significant intervention in infantile colic: results of a community-based study. *J Allergy Clin Immunol* 1995;96:886–92.
- Lucassen PLBJ, Assendelft WJJ, Bubbels JW, van eijk JT, Douwes AC. Infantile colic crying time reduction with a whey hydrolysate: a double-blind randomized placebo-controlled trial. *Pediatr* 2000;106:1349–54.
- Hill DJ, Roy N, Heine RG, Hosking CS, Francis DE, Brown J, et al. Effect of a low allergen maternal diet on colic among breastfed infants: a randomized, controlled trial. *Pediatrics* 2005;116:709–15.
- Al Dhaheri W, Diksic D, Ben-Shoshan M. IgE Mediated cow milk allergy and infantile colic: diagnostic and management challenges. *BMJ Case Rep* 2013.
- Wang J. Oral allergy syndrome in food allergy, adverse reactions to foods and food additives. In: Metcalfe DD, Sampson HA, Simon RA, editors. *Food allergy, adverse reactions to foods and food additives*. Malden, MA: Blackwell Publishing; 2008. p. 133–43 [Ch. 11].
- Katellaris CH. Food allergy and oral allergy or pollen food allergy syndrome. *Curr Opin Allergy Clin Immunol* 2010;10:245–51.
- Hofmann A, Burks AW. Pollen food syndrome: update on the allergens. *Curr Allergy Asthma Rep* 2008;8:413–17.
- Webber CM, England RW. Oral allergy syndrome: a clinical diagnostic and therapeutic challenge. *Ann Allergy Asthma Immunol* 2010;104:101–8.
- Sopo SM, Arena R, Greco M, Bergamini M, Monaco S. Constipation and cow's milk allergy: a review of the literature. *Int Arch Allergy Immunol* 2014;164:40–5.
- Sampson HA, Munoz-Furlong A, Campbell RL, Adkinson NE, Bock SA, Branum A. Second Symposium on the definition and management of anaphylaxis: summary report – Second National Institute of Allergy and Infectious Disease/Food Allergy and Anaphylaxis Network symposium. *J Allergy Clin Immunol* 2006;117:391–7.
- Campbell RL, Hagan JB, Manivannan V, Decker WW, Kanthala AR, Bellolio MF. Evaluation of National Institute of Allergy and Infectious Diseases/FAAN criteria for the diagnosis of anaphylaxis in emergency department patients. *J Allergy Clin Immunol* 2012;129:748–52.
- Nowak R, Farrar JR, Brenner BE, Lewis L, Silverman RA, Emerman C, et al. Customizing anaphylaxis guidelines for emergency medicine. *J Emerg Med* 2013;45:299–306.
- Guandalini S, Assiri A. Celiac disease: a review. *JAMA Pediatr* 2014;163:272–8.
- Ruffner MA, Ruymann K, Barni S, Cianferoni A, Brown-Whitehorn T, Spergel JM. Food protein-induced enterocolitis syndrome: insights from review of a large referral population. *J Allergy Clin Immunol Pract* 2013;1:343–9.
- Jarvinen KM, Nowak-Węgrzyn A. Food protein-induced enterocolitis syndrome (FPIES): current management strategies and review of the literature. *J Allergy Clin Immunol Pract* 2013;1:317–22.
- Giovannini-Chami L, Blanc S, Albertini M, Bourrier T. Frey's syndrome: differential diagnosis of food allergy. *Arch Dis Childhood* 2014;99:457.
- Jovancevic L, Georgalas C, Savovic S, Janjevic D. Gustatory rhinitis. *Rhinology* 2010;48:7–10.
- Roesler TA, Barry PC, Bock SA. Factitious food allergy and failure to thrive. *Arch Pediatr Adolesc Med* 1994;148:1150–5.
- Sicherer SH, Wood RA. Advances in diagnosing peanut allergy. *J Allergy Clin Immunol Pract* 2013;1:1–13.
- Hill DJ, Heine RG, Hosking CS. The diagnostic value of skin prick testing in children with food allergy. *Pediatr Allergy Immunol* 2004;15:435–41.
- Liccardi G, Salzillo A, D'Amato G. The risk of generalized allergic reactions to skin prick testing may be higher in poly-sensitized individuals and in those who underwent SPT with fresh foods. *Pediatr Allergy Immunol* 2010;21:656–7.
- Fleischer DM, Bock SA, Spears GC, Wilson CG, Miyazawa NK, Gleason MC, et al. Oral food challenges in children with a diagnosis of food allergy. *J Pediatr* 2011;158:578–83.
- Noimark L, Cox HE. Nutritional problems related to food allergy in childhood. *Pediatr Allergy Immunol* 2008;19:188–95.
- Ortolani C, Spano M, Pastorello EA, Bigi A, Ansaloni R. Comparison of results of skin prick tests (with fresh foods and commercial food extracts) and RAST in 100 patients with oral allergy syndrome. *J Allergy Clin Immunol* 1989;83:683–90.
- Rance F, Juchet A, Bremont F, Dutau G. Correlations between skin prick tests using commercial extracts and fresh foods, specific IgE, and food challenges. *Allergy* 1997;52:1031–5.
- Begin P, Des RA, Nguyen M, Masse MS, Paradis J, Paradis L. Freezing does not alter antigenic properties of fresh fruits for skin testing in patients with birch tree pollen-induced oral allergy syndrome. *J Allergy Clin Immunol* 2011;127:1624–6.
- Commins SP, James HR, Kelly LA, Pochan SL, Workman LJ, Perzanowski MS, et al. The relevance of tick bites to the production of IgE antibodies to the mammalian oligosaccharide galactose-alpha-1, 3-galactose. *J Allergy Clin Immunol* 2011;127:1286–93.
- Sampson HA, Ho DG. Relationship between food-specific IgE concentrations and the risk of positive food challenges in children and adolescents. *J Allergy Clin Immunol* 1997;100:444–51.
- Sampson HA. Utility of food-specific IgE concentrations in predicting symptomatic food allergy. *J Allergy Clin Immunol* 2001;107:891–6.
- Sicherer SH, Sampson HA. Cow's milk protein-specific IgE concentrations in two age groups of milk-allergic children and in children achieving

- clinical tolerance. *Clin Exp Allergy* 1999;29:507–12.
52. Boyano-Martinez T, Garcia-Ara C, Diaz-Pena JM, Muñoz FM, García Sánchez G, Esteban MM. Validity of specific IgE antibodies in children with egg allergy. *Clin Exp Allergy* 2001;31:1464–9.
  53. Garcia-Ara C, Boyano-Martinez T, Diaz-Pena JM, Martin-Muñoz F, Reche-Frutos M, Martin-Esteban M. Specific IgE levels in the diagnosis of immediate hypersensitivity to cows' milk protein in the infant. *J Allergy Clin Immunol* 2001;107:185–90.
  54. van der Gugten A, den Otter M, Meijer Y, Pasmans S, Knulst AC, Hoekstra MO. Usefulness of specific IgE levels in predicting cow's milk allergy. *J Allergy Clin Immunol* 2008;121:631–3.
  55. Johannsen H, Nolan R, Pascoe EM, Cuthbert P, Noble V, Corderoy T, et al. Skin prick testing and peanut-specific IgE can predict peanut challenge outcomes in preschool children with peanut sensitization. *Clin Exp Allergy* 2011;41:994–1000.
  56. Shek LPC, Soderstrom L, Ahlstedt S, Beyer K, Sampson HA. Determination of food specific IgE levels over time can predict the development of tolerance in cow's milk and hens' egg allergy. *J Allergy Clin Immunol* 2004;114:387–91.
  57. Wood RA, Sicherer SS, Vickery BP, Jones SM, Liu AH, Fleischer DM, et al. The natural history of milk allergy in an observational cohort. *J Allergy Clin Immunol* 2013;131:805–12.
  58. Sicherer SH, Wood RW, Vickery BP, Jones SM, Liu AH, Fleischer DM, et al. The natural history of egg allergy in an observational cohort. *J Allergy Clin Immunol* 2014;133:49.
  59. Wainstein BK, Yee A, Jelley D, Ziegler M, Ziegler JB. Combining skin prick, immediate skin application and specific IgE testing in the diagnosis of peanut allergy in children. *Pediatr Allergy Immunol* 2007;18:231–9.
  60. Dang TD, Tang M, Choo S, Licciardi PV, Koplin JJ, Martin PE, et al. Increasing the accuracy of peanut allergy diagnosis by using Ara h 2. *J Allergy Clin Immunol* 2012;129:1056–63.
  61. Nicolaou N, Poorafshar M, Murray C, Simpson A, Winell H, Kerry G, et al. Allergy or tolerance in children sensitized to peanut: prevalence and differentiation using component-resolved diagnostics. *J Allergy Clin Immunol* 2010;125:191–7.
  62. Asarnoj A, Moverare R, Ostblom E, Poorafshar M, Lilja G, Hedlin G, et al. IgE to peanut allergen components: relation to peanut symptoms and pollen sensitization in 8-year-olds. *Allergy* 2010;65:1189–95.
  63. Vereda A, van Hage M, Ahlstedt S, Ibañez MD, Cuesta-Herranz J, van Odijk J, et al. Peanut allergy: clinical and immunologic differences among patients from 3 different geographic regions. *J Allergy Clin Immunol* 2011;127:603–7.
  64. Keet CA, Johnson K, Savage JH, Hamilton RG, Wood RA. Evaluation of Ara h2 thresholds in the diagnosis of peanut allergy in a clinical population. *J Allergy Clin Immunol Pract* 2013;1:101–3.
  65. Vila L, Beyer K, Jarvinen KM, Chatchatee P, Bardina L, Sampson HA. Role of conformational and linear epitopes in the achievement of tolerance in cow's milk allergy. *Clin Exp Allergy* 2001;31:1599–606.
  66. Chatchatee P, Jarvinen KM, Bardina L, Beyer K, Sampson HA. Identification of IgE- and IgG-binding epitopes on  $\alpha$ s1-casein: differences in patients with persistent and transient cow's milk allergy. *J Allergy Clin Immunol* 2001;107:379–83.
  67. Chatchatee P, Jarvinen KM, Bardina L, Vila L, Beyer K, Sampson HA. Identification of IgE and IgG binding epitopes on beta- and kappa-casein in cow's milk allergic patients. *Clin Exp Allergy* 2001;31:1256–62.
  68. Cocco RR, Jarvinen KM, Sampson HA, Beyer K. Mutational analysis of major, sequential IgE-binding epitopes in  $\alpha$  s1-casein, a major cow's milk allergen. *J Allergy Clin Immunol* 2003;112:433–7.
  69. Jarvinen KM, Beyer K, Vila L, Bardina L, Mishoe M, Sampson HA. Specificity of IgE antibodies to sequential epitopes of hen's egg ovomucoid as a marker for persistence of egg allergy. *Allergy* 2007;62:758–65.
  70. Lemon-Mulé H, Sampson HA, Sicherer SH, Shreffler WG, Noone S, Nowak-Węgrzyn A. Immunologic changes in children with egg allergy ingesting extensively heated egg. *J Allergy Clin Immunol* 2008;122:977–83.
  71. Lin J, Sampson HA. The role of immunoglobulin E-binding epitopes in the characterization of food allergy. *Curr Opin Allergy Clin Immunol* 2009;9:357–63.
  72. Alessandri C, Zennaro D, Scala E. Ovomucoid (Gal d 1) specific IgE detected by microarray system predict tolerability to boiled hen's egg and an increased risk to progress to multiple environmental allergen sensitization. *Clin Exp Allergy* 2012;42:441–50.
  73. Kim JS, Nowak-Węgrzyn A, Sicherer SH. Dietary baked milk accelerates the resolution of cow's milk allergy in children. *J Allergy Clin Immunol* 2011;128:125–31.
  74. Shreffler WG, Beyer K, Chu TH, Burks AW, Sampson HA. Microarray immunoassay: association of clinical history, in vitro IgE function, and heterogeneity of allergenic peanut epitopes. *J Allergy Clin Immunol* 2004;113:446–82.
  75. Shreffler WG, Lencer DA, Bardina L, Sampson HA. IgE and IgG4 epitope mapping by microarray immunoassay reveals the diversity of immune response to the peanut allergen, Ara h 2. *J Allergy Clin Immunol* 2005;116:893–9.
  76. Cerecedo I, Zamora J, Shreffler WG, Lin J, Bardina L, Diequez MC, et al. Mapping of the IgE and IgG4 sequential epitopes of milk allergens with a peptide microarray-based immunoassay. *J Allergy Clin Immunol* 2008;122:589–94.
  77. Sanz ML, Blazquez AB, Garcia BE. Microarray of allergenic component-based diagnosis in food allergy. *Curr Opin Allergy Clin Immunol* 2011;11:204–9.
  78. Lin J, Bruni FM, Fu Z, Maloney J, Bardina L, Boner AL, et al. A bioinformatics approach to identify patients with symptomatic peanut allergy using peptide microarray immunoassay. *J Allergy Clin Immunol* 2012;129:1321–8.
  79. Stapel SO, Asero R, Ballmer-Weber BK, Zeiger RS, Lehrer S, Sachs M, et al. Testing for IgG4 against foods is not recommended as a diagnostic tool. EAACI task force report. *Allergy* 2008;63:793–6.
  80. Burks AW, Tang M, Sicherer S, Muraro A, Eigenmann PA, Ebisawa M, et al. ICON: food allergy. *J Allergy Clin Immunol* 2012;129:906–20.
  81. Bock SA, Sampson HA, Atkins FM, Zeiger RS, Lehrer S, Sachs M, et al. Double blind placebo controlled food challenge (DBPCFC) as an office procedure: a manual. *J Allergy Clin Immunol* 1988;82:986–97.
  82. Niggemann B, Beyer K. Diagnosis of food allergy in children: toward a standardization of food challenge. *J Pediatr Gastroenterol Nutr* 2007;45:399–404.
  83. Sicherer SH. Food allergy: when and how to perform oral food challenges. *Pediatr Allergy Immunol* 1999;10:226–34.
  84. Vlieg-Boerstra BJ, Bijleveld CMA, van der Heide S, Beusekamp BJ, Wolt-Plompen SA, Kukler J, et al. Development and validation of challenge materials for double-blind, placebo-controlled food challenges in children. *J Allergy Clin Immunol* 2004;113:341–6.
  85. Huijbers GB, Colen AAM, Jansen JJ, Kardinaal AF, Vlieg-Boerstra BJ, Martens BP. Masking foods for food challenge: practical aspects of masking foods for a double-blind, placebo-controlled food challenge. *J Am Dietetic Assn* 1994;94:645–9.
  86. Sampson HA. Use of food-challenge tests in children. *Lancet* 2001;358:1832–3.
  87. Nowak-Węgrzyn A, Assa'ad AH, Bahna SL, Bock SA, Sicherer SH, Teuber SS. Oral food challenge: a working group report. *J Allergy Clin Immunol* 2009;123:S365–83.
  88. Niggemann B. When is an oral food challenge positive. *Allergy* 2010;65:2–6.
  89. Sampson HA, van Wijk RG, Bindslev-Jensen C, Sicherer SH, Teuber SS, Burks AW, et al. Standardizing double-blind, placebo-controlled oral food challenges: American Academy of Allergy, Asthma & Immunology-European Academy of Allergy and Clinical Immunology PRACTALL consensus report. *J Allergy Clin Immunol* 2012;130:1260–74.
  90. Niggemann B, Lange L, Finger A, Ziegert M, Müller V, Beyer K. Accurate oral food challenge requires a cumulative dose on a subsequent day. *J Allergy Clin Immunol* 2012;130:261–3.
  91. Vlieg-Boerstra BJ, van der Heide S, Bijleveld CMA, Kukler J, Duiverman EJ, Dubois AE. Placebo reactions in double-blind placebo-controlled food challenges in children. *Allergy* 2007;62:905–12.

# Approach to Feeding Problems in the Infant and Young Child

ARNE HØST | SUSANNE HALKEN

## KEY POINTS

- Infants most often develop food allergies in the order of exposure (e.g. milk, egg, fish, vegetables, etc.).
- The majority of infants and young children with food allergies have symptoms that affect at least two organs (cutaneous, gastrointestinal or respiratory).
- The most frequent allergic gastrointestinal reactions to food in infants and young children include colic, vomiting, diarrhea and failure to thrive. None of these is pathognomonic for allergy and may be caused by many other conditions.
- Food allergy should be suspected in cases of persistent severe symptoms, symptoms related to food intake, two or more different symptoms, two or more organ systems involved and allergic predisposition.
- Among children presenting with symptoms suggestive of food allergy, the diagnosis can be confirmed by controlled elimination/food challenge procedures in only about one third.

For the past decades, an increasing awareness of food allergy has emerged in western industrialized societies where confirmed food allergy seems to affect around 3% to 7% of young children and 3% to 5% of adults depending on population, methods and diagnostic criteria.<sup>1,2</sup> However, the public perceives food allergy to be much more common.<sup>2-4</sup> Given the public's frequent misperception that various mild symptoms are caused by food-induced allergic reactions, performing a careful evaluation and correct diagnostic procedures is imperative to avoid over-diagnosis, which may lead to malnutrition, eating disorders and psychosocial problems, as well as family disruption.<sup>1,5</sup> In contrast, under-diagnosis may result in unnecessary symptoms, growth failure and physical impairment.

True food allergies (i.e. immune-mediated reactions) are most often immunoglobulin E (IgE)-mediated reactions. However, non-IgE-mediated reactions may play a major role in delayed reactions.<sup>1,5</sup> It is evident that a correct classification of an adverse reaction to foods will depend on the extent and the quality of the diagnostic tests and procedures performed.

No single laboratory test is diagnostic of food allergy. Therefore, the diagnosis has to be based on strict, well-defined food elimination and oral challenge procedures, preferably double-blind, placebo-controlled food challenges (DBPCFCs) in children older than 2–3 years and in cases of subjective symptoms.<sup>5-7</sup> In infants, open, controlled challenges have been shown to be reliable when performed under professional observation in a hospital setting or a clinic.<sup>8,9</sup> Food allergy is primarily a problem

in infancy and early childhood. Most often the infants develop food allergies in the same order as the introduction of foods into the diet. Thus, the prevalence of reactions to different foods depends in part on the eating habits of a given population.<sup>10,11</sup>

This review concentrates on gastrointestinal symptoms, which may cause suspicion of food allergy in early childhood, focussing on indications for food allergy evaluation. Specific disease entities, such as enterocolitis, proctocolitis, enteropathies and allergic eosinophilic esophagitis/gastroenterocolitis, are discussed in Chapters 44 and 45.

## Frequency

In prospective studies, the incidence of cow's milk protein allergy (CMPA) during the first year of life has been estimated to be about 2% to 3% based on strict diagnostic criteria, as reviewed by Høst.<sup>12</sup> Other common food allergens in children are egg, peanuts, tree nuts, soy, fish and cereal grains.<sup>11</sup> The total cumulated incidence of food protein allergy during the first 3 to 5 years of life has been found to be about 4% to 7%.<sup>2,13,14</sup> In a prospective birth cohort study, the point prevalence of food allergy at 3 years was 2.3%.<sup>4</sup>

Adverse reactions to *food additives* have been demonstrated to affect less than 1% of unselected school children when using DBPCFCs.<sup>15</sup> The most common positive reaction was worsening of atopic eczema and urticaria in atopic children. Among children with atopic symptoms referred to hospital allergy clinics,<sup>16</sup> 23% were suspected of food additive intolerance. However, only 7% reacted to food additives on open challenge and only 2% had reproducible reactions when DBPCFCs were performed. Another study indicates that artificial colors and/or preservatives (sodium benzoate) in the diet may result in a dose-dependent increased hyperactivity in 3-year-old and 8–9-year-old children in the general population.<sup>17</sup>

In children with symptoms suggestive of food allergy, it has been possible to confirm the diagnosis in only about one third by means of controlled elimination/challenge procedures.<sup>2,3,5,12,14</sup>

## Age at Onset of Symptoms

The age at which symptoms start depends on the time of introduction of the foods; infants frequently develop food allergies in the same order as that in which the foods have been introduced into the diet. Many prospective studies have demonstrated that symptoms in CMPA develop in early infancy, rarely after 12 months of age.<sup>12</sup> The onset of disease is, in most cases, closely related to the time of introduction of cow's milk-based formula. Allergy to hen's egg is also more common in younger children, whereas allergies against peanut, tree nuts, fish and



**TABLE 42-1** Age at Onset of Food Allergy Against Different Foods

Age (Years)	Food
0–1	Milk, eggs
1–2	Peanuts, fish in Scandinavian countries
>2	Fruits, legumes, vegetables
>3	Pollen-related cross-reactivities (oral allergy syndrome)

**TABLE 42-2** Clinical Features of Food Allergy in Children and Their Most Frequent Mechanisms

<b>CUTANEOUS REACTIONS</b>	
IgE mediated	Urticaria, acute or chronic (rare) Angioedema Atopic dermatitis
Non-IgE mediated	Atopic dermatitis Contact rash (e.g. perioral flare due to benzoic acid in citrus fruits)
<b>GASTROINTESTINAL REACTIONS</b>	
IgE-mediated	Immediate gastrointestinal hypersensitivity (e.g. nausea, vomiting, diarrhea) Oral allergy syndrome Colic
Non-IgE-mediated	Allergic eosinophilic esophagitis, gastritis or gastroenterocolitis Enterocolitis syndrome Dietary protein colitis Dietary protein enteropathy
<b>RESPIRATORY REACTIONS</b>	
IgE-mediated	Rhinoconjunctivitis Asthma (wheezing, cough) Laryngeal edema Food-dependent exercise-induced asthma
Non-IgE-mediated	Pulmonary hemosiderosis (Heiner's syndrome [rare])
<b>SYSTEMIC ANAPHYLAXIS</b>	
IgE-mediated	Anaphylaxis Food-dependent exercise-induced anaphylaxis
<b>OTHER REACTIONS</b>	
IgE-mediated	Otitis media (secondary to allergic rhinitis and Eustachian tube dysfunction) or an allergic middle ear inflammation)
Unknown mechanisms	Migraine (rare), arthritis (rare), Henoch-Schönlein purpura (rare)

shellfish, fruit and fruit juice often have a later age of onset.<sup>11,14</sup> In a Spanish study,<sup>10</sup> this relationship between the age of introduction of various foods into the child's diet and allergy to these foods was demonstrated (Table 42-1).

## Clinical Features

The clinical features of food allergy in childhood are shown in Table 42-2. In early infancy the most common food allergy is to cow's milk protein. Similar to other food allergies, the majority have at least two symptoms and symptoms that affect at least two organ systems. About 50% to 70% have cutaneous symptoms; 50% to 60% gastrointestinal symptoms and about 20%

to 30% respiratory symptoms.<sup>8</sup> Also, approximately 0.5% of exclusively breastfed infants may react to food protein in their mother's milk,<sup>12</sup> and in these infants severe atopic eczema is the predominant symptom.

Symptoms occurring within a few minutes to 2 hours after food exposure (i.e. 'immediate reactions') are mostly IgE-mediated, whereas symptoms occurring more than 2 hours after food intake are classified as delayed reactions and are typically not IgE-mediated. Late reactions may occur after many hours even up to a few days, such as in allergic eosinophilic gastroenteritis. Delayed reactions are mostly non-IgE mediated. Anaphylaxis has been reported with varying frequencies, reflecting differences in patient selection. It is clear that patterns of reactions to foods may vary due to different exposure levels and different time intervals between exposures, as well as different thresholds of reaction.

*Immediate IgE-mediated reactions* to foods often involve two or more target organs, such as the gastrointestinal tract, the skin and the lungs, and may result in a variety of symptoms, including life-threatening reactions such as exacerbations of asthma, laryngeal edema and anaphylaxis with cardiovascular collapse. An exception is the *food-pollen allergy*, or *oral allergy syndrome* (OAS), a mucosal equivalent of urticaria, which is described in Chapter 46. OAS is associated with allergic rhinoconjunctivitis and allergy to specific pollen, e.g. birch, ragweed and mugwort pollens, and is most often elicited by specific foods with pollen IgE cross-reacting with homologous proteins in fresh fruits or vegetables. After ingestion, pruritus and swelling in the mouth and oropharynx occurs, which may prompt the child to refuse the offending foods. However, in some cases OAS may progress to more severe reactions.<sup>18</sup>

## Gastrointestinal Problems in Early Childhood

Gastrointestinal manifestations of food allergy can be classified as a continuum from clearly IgE-mediated to mixed reactions dominated by eosinophilic granulocytes, to clearly non-IgE-mediated reactions.<sup>19,20</sup> Immediate gastrointestinal hypersensitivity and oral allergy symptoms are mainly IgE-mediated; allergic eosinophilic esophagitis, allergic eosinophilic gastritis, and allergic eosinophilic gastroenterocolitis are mixed-IgE and non-IgE-mediated reactions, and food protein-induced enterocolitis, proctocolitis and enteropathy, and celiac disease are non-IgE mediated. The most frequent adverse reactions to food in the infant and young child are immediate IgE-mediated reactions with manifestations such as nausea, abdominal pain (colic) and vomiting within 1 to 2 hours after food intake, and diarrhea within 1 to 6 hours. The frequency of presenting gastrointestinal symptoms in infants with CMPA is shown in Table 42-3.

Among non-IgE-mediated disorders, food protein-induced enterocolitis and proctocolitis typically have their onset in early infancy, up to 6 to 18 months of age. Mixed IgE- and cell-mediated reactions, allergic eosinophilic esophagitis and allergic eosinophilic gastroenterocolitis may present between early infancy and adolescence. Dietary protein enteropathy and celiac disease occur in early childhood, depending on the age of exposure to the antigen involved. The mixed-IgE- and non-IgE-mediated disorders are discussed in detail in Chapters 44 and 45.

The symptoms provoked by immediate gastrointestinal allergy typically develop within minutes to 2 hours after food

TABLE  
42-3

Presenting Gastrointestinal Symptoms in Infants with Cow's Milk Protein Allergy

Symptom	SELECTED PATIENT SAMPLES (%)			UNSELECTED PATIENTS COHORTS, PROSPECTIVELY FOLLOWED FROM BIRTH (%)		
	Goldman et al (1963) <sup>21*</sup>	Gerrard et al (1967) <sup>22†</sup>	Hill et al (1986) <sup>23‡</sup>	Gerrard et al (1973) <sup>24§</sup>	Jakobsson and Lindberg (1979) <sup>25  </sup>	Høst and Halken (1990) <sup>8¶</sup>
	N = 89	N = 150	N = 100	N = 59	N = 20	N = 39
Colic	28	19	14	20	35	46
Vomiting	33	34	34	22	50	38
Diarrhea	37	47	48	41	25	8
Failure to thrive	NG	NG	22	NG	10	8
Diarrhea with blood	NG	NG	4	NG	NG	0
Gastroesophageal reflux	NG	NG	6	NG	NG	NG

NG – Not given.

\*Age at investigation: Group A median, 6 months (2 weeks to 6 years); group B median, 10 months (6 weeks to 13 years).

†Age at investigation: not given.

‡Age at investigation: mean, 16 months (3 to 66 months).

§Age at investigation: not given, but infants followed for 0 to 2 years.

||Age at investigation: median, 4 months (3 weeks to 1 year).

¶Age at investigation: median, 3.5 months (1 to 11 months), infants followed for 0 to 3 years.

intake. None of the symptoms is pathognomonic for allergy and may be caused by many other factors or diseases. Symptoms like colic, vomiting and diarrhea may be chronic or intermittent. Frequently, the children have a poor appetite, poor weight gain, intermittent abdominal pain and failure to thrive. Children who show concomitant symptoms in other organ systems like urticaria or atopic dermatitis or respiratory symptoms may easily be suspected of having a food allergy. When symptoms from other organ systems are lacking, the cause of the symptoms may remain undiagnosed for prolonged periods. A family history of atopic disease in such cases should give a clue to the diagnosis of possible food allergy. A variety of feeding problems in young infants may be associated with food allergy. Allergic gastrointestinal motility disorders such as gastroesophageal reflux disease (GERD), constipation and colic are among the most common disorders in infancy and early childhood. In a subset of infants with these functional disorders, a relation with food allergy has been reported following controlled food elimination and challenge procedures.<sup>26</sup>

## INFANTILE COLIC

Infantile colic has often been related to food allergy,<sup>18</sup> especially CMPA, and high frequencies of food allergy of up to 71% have been in children with colic.<sup>27</sup> In that and another study,<sup>28</sup> the infants with colic due to cow's milk protein only rarely showed other features of CMPA. Although infantile colic is a common symptom of CMPA, it is almost always seen in combination with other features of CMPA.<sup>8,29</sup>

## GASTROESOPHAGEAL REFLUX DISEASE

It has been reported that nearly half of the cases of GERD in infants younger than 1 year of age are not only CMPA associated but also CMPA induced.<sup>18,30,31</sup> GERD is a common disease, affecting up to 10% of infants in the first year of life. It is related to esophagitis but may be present without visible or histologic inflammation of the esophagus. Typical symptoms of GERD include vomiting with weight loss and symptoms of esophagitis (dysphagia, vomiting, abdominal pain, sleep disturbance), as

### BOX 42-1 SYMPTOMS OF GASTROESOPHAGEAL REFLUX DISEASE

- Regurgitation
- Failure to thrive
- Esophagitis
- Feeding problems
- Signs of pain, especially with meals
- Anemia, hematemesis
- Stricture symptoms
- Respiratory symptoms
- Wheezing
- Recurrent pneumonia
- Apnea, cyanotic episodes
- Laryngospasm
- Neurologic symptoms
- Sandifer's syndrome

well as respiratory symptoms (Box 42-1). Proteins other than cow's milk protein have been implicated in allergic eosinophilic esophagitis, such as wheat, soy, peanut and egg; often multiple antigens. Most cases in young infants resolve in less than 1 year. Some studies suggest that a portion of patients have both CMPA and GERD, particularly infants and children with severe GERD.<sup>32</sup> Given possible selection bias in previously reported studies, more population-based studies on this subject are warranted to evaluate the significance of this possible causal relationship.

## CONSTIPATION

Constipation is a common clinical problem affecting up to 10% of infants and children,<sup>33</sup> and in a population-based study from Italy, 1.8% (91/5113) of children up to 12 years of age fulfilled the criteria for chronic constipation with the highest frequency (3.3%) among children aged 6 months to 6 years.<sup>34</sup> Chronic constipation may cause blood in the stools as well as symptoms of colitis and recurrent abdominal pain in older children. Some reports<sup>35-37</sup> describe chronic constipation as a manifestation of CMPA. In a recent study, the prevalence of atopy among children with chronic constipation was similar to that in the general

population.<sup>34</sup> Thus, food allergy should be considered in severe cases of chronic constipation, but constipation does not appear to be a common manifestation of food allergy.

## DIARRHEA

Diarrhea is often reported as a symptom of food allergy in young infancy. On the other hand, diarrhea is also a very common symptom due to ‘normal reactions’ caused by inappropriate or excessive intake of certain foods, such as raisins, carrots, legumes and other fruit – toddler’s diarrhea. Transient or secondary lactase deficiency may occur in response to gastrointestinal infections, which are very common in infancy. This intolerance to lactose often lasts only a few days, after which there is a complete recovery.<sup>38</sup>

## SPITTING UP/VOMITING

Symptoms of spitting up and vomiting may be very normal in young infants. The most common cause of vomiting is over-feeding. Such infants show normal growth and development, in contrast to infants with underlying gastrointestinal disease.<sup>19</sup> In some cases, nonorganic causes, e.g. behavioral causes, should be considered.<sup>39</sup>

## FAILURE TO THRIVE

Failure to thrive may be caused by immediate gastrointestinal food allergy but is more often due to mixed-IgE- and non-IgE-mediated disorders of the gastrointestinal tract causing malabsorption, severe vomiting or diarrhea.<sup>18,19</sup> In some children with failure to thrive, organic causes cannot be demonstrated and it may be very difficult to confirm nonorganic causes. A report indicated the relevance of ‘behavioral causes’ such as food refusal, food fixation, abnormal parental feeding practices and onset after a specific trigger.<sup>39</sup>

## Differential Diagnoses

The differential diagnostic considerations of possible food-related symptoms are age dependent and include, for example, chronic gastrointestinal infections, nonspecific diarrhea of childhood, irritable bowel syndrome and recurrent abdominal pain, as described in [Box 42-2](#). Some differential diagnoses of food allergy are mainly related to the upper gastrointestinal tract whereas others are associated with diseases in the lower gastrointestinal tract.

### NONENTERAL INFECTIONS

Commonly seen in all ages, although most frequent in early infancy, are the nonenteral infections that may cause gastrointestinal upset, regardless of the focus of the infection; ‘secondary dyspepsia’. Such sequelae after acute or chronic gastrointestinal infection should always be ruled out before evaluation of food allergy.

### LACTOSE INTOLERANCE

Lactose intolerance is an important differential to consider in the diagnosis of food allergy, especially cow’s milk allergy. Lactose constitutes a majority of the carbohydrate content of

## BOX 42-2 DIFFERENTIAL DIAGNOSES OF FOOD ALLERGY

### INFANT

Upper gastrointestinal symptoms  
 Infection  
 Colic\*  
 Gastroesophageal reflux\*  
 Pyloric stenosis (defined age group)  
 Hiatal hernia  
 Tracheoesophageal fistula  
 Lower gastrointestinal symptoms  
 Enzyme deficiency  
 Disaccharidase deficiencies (lactase, sucrase-isomaltase)  
 Glucose-galactose malabsorption  
 Galactosemia  
 Phenylketonuria  
 Infection  
 Constipation\*  
 Hirschsprung’s disease

### TODDLER

Infection  
 Toddler’s diarrhea  
 Gastroesophageal reflux\*  
 Constipation\*  
 Lactose intolerance  
 Malabsorption (celiac disease, cystic fibrosis)  
 Bizarre diets

### SCHOOL-AGE CHILD

Infection  
 Recurrent abdominal pain  
 Lactose intolerance  
 Malabsorption (celiac disease, cystic fibrosis, Schwachman syndrome)  
 Inflammatory bowel disease  
 Eosinophilic gastroenteritis\*  
 Other causes (immunodeficiency, Henoch-Schönlein disease)

\*Could be caused by food allergy.

human and cow’s milk and is an important part of the energy supply for infants in particular. Lactose is degraded in the gastrointestinal mucosa by the enzyme lactase. Lactose intolerance in the newborn is extremely rare and is caused by congenital deficiency of lactase. Acquired or adult-type lactase deficiency usually appears at the age of 3 to 5 years. Adult-type lactase deficiency is very common in those of African and Asian descent. It is less common in whites, especially in some groups such as the Scandinavian populations; in Denmark, only 3% of adults are affected.

Secondary lactase deficiency is temporary and may occur in response to malnutrition or gastrointestinal infections, which cause temporary damage to the villi of the small intestine, where the enzyme lactase is produced. This sensitivity to lactose often lasts only a few days, followed by complete recovery.

Lactase deficiency (lactose malabsorption) may or may not be associated with gastrointestinal symptoms, depending on many factors and co-existing conditions. Lactose intolerance is defined as a condition with gastrointestinal symptoms after ingestion of lactose in a person with lactase deficiency.<sup>38</sup>

Lactose intolerance may be diagnosed by oral lactose challenge tests and measurements of increased breath hydrogen, by glucose measurements or by direct enzyme measurements within a duodenal biopsy. A genetic test to diagnose the adult

type of lactase deficiency was found to be valid, especially in older children.<sup>38,40</sup> Recently, it has been proposed that such tests should be followed by a blinded single-dose challenge of ingested lactose.<sup>38</sup>

Adult-type or primary lactase deficiency is a lifelong condition. The treatment of lactose intolerance is reduced ingestion of milk and dairy products with lactose. Avoidance does not need to be complete, such as for children with CMPA. A firm diagnosis of lactose intolerance and the threshold for development of symptoms should be established because the sensitivity to lactose is variable. In most lactose-intolerant individuals, considerable amounts of lactose – usually up to 250 mL of milk – may be ingested before symptoms develop. Lactase enzyme replacement is another treatment option.<sup>38</sup>

## IRRITABLE BOWEL SYNDROME

Irritable bowel syndrome (IBS) or recurrent abdominal pain in children is a clinical syndrome with a variable pathogenic background, including psychosomatic reactions, lactose intolerance, food allergy and inflammatory conditions such as gastritis or inflammatory bowel disease. It has been concluded that food reactions are unlikely to be major determinants in the pathogenesis of IBS and that double-blind, placebo-controlled food challenges are mandatory for investigation of this possible causal relationship.<sup>41,42</sup>

## TODDLER'S DIARRHEA

To avoid unnecessary investigations for food allergy, it is important to pay attention to this very common 'disorder'. Many infants and young children have a high intake of dietary fiber and fruit sugar from high amounts of fruits, legumes, vegetables, raisins and great volumes of fruit juice. This is a normal cause of loose stools and diarrhea, often resulting in referrals to allergists for investigation of food allergy, which is unnecessary when children have normal growth and development. Laypersons, especially parents, need more information and knowledge about 'normal' reactions to foods in children. The simple advice is to reduce the intake of such foods.

## MÜNCHHAUSEN'S SYNDROME BY PROXY

During the past decades, many infants and young children have been investigated for food allergy without a convincing indication for such, often comprehensive, diagnostic procedures. In cases where there is a lack of obvious possible allergic symptoms, physicians should abstain from unnecessary and potentially harmful investigations of healthy children with parent-, often mother-, induced or imaginary symptoms.<sup>43</sup>

## Evaluation and Management

In infants and young children, food allergy should be suspected if severe symptoms persist, especially if there is more than one symptom and if relevant differential diagnoses have been excluded (Boxes 42-3 and 42-4).

Gastrointestinal symptoms in food allergy are often chronic or acute vomiting, diarrhea and colic. Colic appears to be a common symptom,<sup>18</sup> but as already mentioned nearly always occurs in combination with other symptoms.<sup>8,12,29</sup> Since most of these gastrointestinal symptoms are nonspecific and may be

### BOX 42-3 KEY CONCEPTS

#### Characteristics of Food Allergy

- Persistent symptoms
- Symptoms related to food intake
- Two or more different symptoms
- Symptoms in two or more different organs
- Allergic predisposition

### BOX 42-4 THERAPEUTIC PRINCIPLES

#### General Approach to Evaluation of Food Allergy in Children with Gastrointestinal Problems

##### CONSIDER EVALUATION IN CASE OF:

- Persistent symptoms in infant/young child with vomiting, diarrhea, colic or failure to thrive, and
- Other common differential diagnoses are excluded, especially gastroenteritis and lactose intolerance
- Particularly in cases where:
  - History of symptoms exacerbated by particular foods or
  - Other coexisting atopic manifestations, especially
    - Atopic eczema/urticaria
    - Allergic rhinitis
- Initial screen
- Careful case history and physical examination
- Skin prick test/specific IgE to implicated foods
  - Extra suspicion for 'history-positive' foods
  - Extra suspicion for common food allergens (milk, hen's egg, wheat, soy, peanut, tree nut, fish, shellfish)
- Consider elimination diet for a sufficient period to eliminate symptoms
- Consider controlled oral challenges to exclude/confirm food allergy

caused by other conditions, a careful evaluation for other causes is important at an early stage.

None of the symptoms related to immunologically or non-immunologically mediated adverse reactions to foods is pathognomonic, although some characteristics should be suggestive of food allergy (Box 42-3).

No laboratory test is diagnostic of food allergy.<sup>1,6,9,20</sup> Therefore, the diagnosis has to be based on a careful case history and on strict, well-defined food elimination and challenge procedures establishing a causal relation between the ingestion of a particular food (or food protein) and a subsequent obvious clinical reaction<sup>1,6,9,19,20</sup> (see also Chapter 41). Possible helpful diagnostic tests include skin prick tests or determinations of serum allergen-specific IgE levels. These tests are often useful in choosing the elimination diet and the challenge procedure for the classification of the disorder and for determining the prognosis.

## Conclusions

Food allergy is most frequently a problem in infancy and early childhood. Children with food allergy may experience a variety of symptoms affecting different organ systems and leading to feeding disorders. The disease manifestations often are localized to the gastrointestinal tract, but food allergy may also cause local symptoms in the skin and the respiratory tract. About



50% to 70% of food allergic infants show cutaneous symptoms, 50% to 60% gastrointestinal symptoms and about 20% to 30% respiratory symptoms. Among young children with cow's milk allergy, the majority have two or more symptoms, and symptoms generally affect two or more organ systems. Mostly, the symptoms occur within a few minutes after food exposure (immediate reactions), but delayed reactions involving the skin, gastrointestinal tract and lungs may also occur. Among children presenting with symptoms suggestive of food allergy, the diagnosis can be confirmed by controlled elimination/challenge procedures in only about one third of individuals.

To avoid unnecessary diets and stigmatization, it is important to rule-out 'normal reactions' to foods and relevant differential diagnoses before undertaking specific comprehensive diagnostic procedures for food allergy. To avoid unnecessary diets, malnutrition and severe reactions such as anaphylaxis, it is important to make the proper diagnosis in case of suspected food allergy.

The complete reference list can be found on the companion Expert Consult website at <http://www.expertconsult.inkling.com>.



## KEY REFERENCES

1. Sicherer SH, Sampson HA. Food allergy: Epidemiology, pathogenesis, diagnosis, and treatment. *J Allergy Clin Immunol* 2014;133:291–307.
2. Nwaru BI, Hickstein L, Panesar SS, Muraro A, Werfel T, Cardona V, et al. The epidemiology of food allergy in Europe: a systematic review and meta-analysis. *Allergy* 2013;69:62–75.
5. Muraro A, Werfel T, Hoffmann-Sommergruber K, Roberts G, Beyer K, Bindslev-Jensen C, et al. EAACI Food Allergy and Anaphylaxis Guidelines: diagnosis and management of food allergy. *Allergy* 2014;69:1008–25.
11. Nwaru BI, Hickstein L, Panesar SS, Roberts G, Muraro A, Sheikh A. Prevalence of common food allergies in Europe: a systematic review and meta-analysis. *Allergy* 2014;69:992–1007.
18. Ho MH, Wong WH, Chang C. Clinical spectrum of food allergies: a comprehensive review. *Clin Rev Allergy Immunol* 2014;46:225–40.
20. Sicherer SH, Sampson HA. Food allergy. *J Allergy Clin Immunol* 2010;125(2 Suppl. 2): S116–25.
26. Heine RG. Allergic gastrointestinal motility disorders in infancy and early childhood. *Pediatr Allergy Immunol* 2008;19:383–91.
38. Misselwitz B, Pohl D, Fruhauf H, Fried M, Vavricka SR, Fox M. Lactose malabsorption and intolerance: pathogenesis, diagnosis and treatment. *United Eur Gastroenterol J* 2013;1: 151–9.
39. Levy Y, Levy A, Zangen T, Kornfeld L, Dalal I, Samul E, et al. Diagnostic clues for identification of nonorganic and organic causes of food refusal and poor feeding. *J Pediatr Gastroenterol Nutr* 2009;48:355–62.
42. Cuomo R, Andreozzi P, Zito FP, Passananti V, De Carlo G, Sarnelli G. Irritable bowel syndrome and food interaction. *World J Gastroenterol* 2014;20:8837–45.

## REFERENCES

- Sicherer SH, Sampson HA. Food allergy: Epidemiology, pathogenesis, diagnosis, and treatment. *J Allergy Clin Immunol* 2014;133:291–307.
- Nwaru BI, Hickstein L, Panesar SS, Muraro A, Werfel T, Cardona V, et al. The epidemiology of food allergy in Europe: a systematic review and meta-analysis. *Allergy* 2013;69:62–75.
- Rona RJ, Keil T, Summers C, Gislason D, Zuidmeer L, Sodergren E, et al. The prevalence of food allergy: a meta-analysis. *J Allergy Clin Immunol* 2007;120:638–46.
- Osterballe M, Hansen TK, Mortz CG, Host A, Bindslev-Jensen C. The prevalence of food hypersensitivity in an unselected population of children and adults. *Pediatr Allergy Immunol* 2005;16:567–73.
- Muraro A, Werfel T, Hoffmann-Sommergruber K, Roberts G, Beyer K, Bindslev-Jensen C, et al. EAACI Food Allergy and Anaphylaxis Guidelines: diagnosis and management of food allergy. *Allergy* 2014;69:1008–25.
- Bindslev-Jensen C, Ballmer-Weber BK, Bengtsson U, Blanco C, Ebner C, Hourihane J, et al. Standardization of food challenges in patients with immediate reactions to foods – position paper from the European Academy of Allergology and Clinical Immunology. *Allergy* 2004;59:690–7.
- Venter C, Pereira B, Voigt K, Grundy J, Clayton CB, Gant C, et al. Comparison of open and double-blind placebo-controlled food challenges in diagnosis of food hypersensitivity amongst children. *J Hum Nutr Diet* 2007;20:565–79.
- Høst A, Halken S. A prospective study of cow milk allergy in Danish infants during the first 3 years of life. Clinical course in relation to clinical and immunological type of hypersensitivity reaction. *Allergy* 1990;45:587–96.
- Niggemann B, Beyer K. Diagnosis of food allergy in children: toward a standardization of food challenge. *J Pediatr Gastroenterol Nutr* 2007;45:399–404.
- Crespo JF, Pascual C, Burks AW, Helm RM, Esteban MM. Frequency of food allergy in a pediatric population from Spain. *Pediatr Allergy Immunol* 1995;6:39–43.
- Nwaru BI, Hickstein L, Panesar SS, Roberts G, Muraro A, Sheikh A. Prevalence of common food allergies in Europe: a systematic review and meta-analysis. *Allergy* 2014;69:992–1007.
- Høst A. Cow's milk protein allergy and intolerance in infancy. Some clinical, epidemiological and immunological aspects. *Pediatr Allergy Immunol* 1994;5(5 Suppl.):1–36.
- Venter C, Pereira B, Voigt K, Grundy J, Clayton CB, Higgins B, et al. Prevalence and cumulative incidence of food hypersensitivity in the first 3 years of life. *Allergy* 2008;63:354–9.
- Bock SA. Prospective appraisal of complaints of adverse reactions to foods in children during the first 3 years of life. *Pediatrics* 1987;79:683–8.
- Fuglsang G, Madsen C, Saval P, Osterballe O. Prevalence of intolerance to food additives among Danish school children. *Pediatr Allergy Immunol* 1993;4:123–9.
- Fuglsang G, Madsen G, Halken S, Jorgensen S, Ostergaard PA, Osterballe O. Adverse reactions to food additives in children with atopic symptoms. *Allergy* 1994;49:31–7.
- McCann D, Barrett A, Cooper A, Crumpler D, Dalen L, Grimshaw K, et al. Food additives and hyperactive behaviour in 3-year-old and 8/9-year-old children in the community: a randomised, double-blinded, placebo-controlled trial. *Lancet* 2007;370:1560–7.
- Ho MH, Wong WH, Chang C. Clinical spectrum of food allergies: a comprehensive review. *Clin Rev Allergy Immunol* 2014;46:225–40.
- Sampson HA, Anderson JA. Summary and recommendations: classification of gastrointestinal manifestations due to immunologic reactions to foods in infants and young children. *J Pediatr Gastroenterol Nutr* 2000;30(Suppl.):S87–94.
- Sicherer SH, Sampson HA. Food allergy. *J Allergy Clin Immunol* 2010;125(2 Suppl. 2):S116–25.
- Goldman AS, Anderson DW, Jr, Sellers WA, Saperstein S, Kniker WT, Halpern SR. Milk allergy. I. Oral challenge with milk and isolated milk proteins in allergic children. *Pediatrics* 1963;32:425–43.
- Gerrard JW, Lubos MC, Hardy LW, Holmlund BA, Webster D. Milk allergy: clinical picture and familial incidence. *Can Med Assoc J* 1967;23:97:780–5.
- Hill DJ, Firer MA, Shelton MJ, Hosking CS. Manifestations of milk allergy in infancy: clinical and immunologic findings. *J Pediatr* 1986;109:270–6.
- Gerrard JW, MacKenzie JW, Goluboff N, Garson JZ, Maningas CS. Cow's milk allergy: prevalence and manifestations in an unselected series of newborns. *Acta Paediatr Scand Suppl* 1973;234:1–21.
- Jakobsson I, Lindberg T. A prospective study of cow's milk protein intolerance in Swedish infants. *Acta Paediatr Scand* 1979;68:853–9.
- Heine RG. Allergic gastrointestinal motility disorders in infancy and early childhood. *Pediatr Allergy Immunol* 2008;19:383–91.
- Iacono G, Carroccio A, Montalto G, Cavataio F, Bragion E, Lorello D, et al. Severe infantile colic and food intolerance: a long-term prospective study. *J Pediatr Gastroenterol Nutr* 1991;12:332–5.
- Lothe L, Lindberg T, Jakobsson I. Cow's milk formula as a cause of infantile colic: a double-blind study. *Pediatrics* 1982;70:7–10.
- Hill DJ, Hosking CS. Infantile colic and food hypersensitivity. *J Pediatr Gastroenterol Nutr* 2000;30(Suppl.):S67–76.
- Cavataio F, Iacono G, Montalto G, Soresi M, Tumminello M, Carroccio A. Clinical and pH-metric characteristics of gastro-oesophageal reflux secondary to cows' milk protein allergy. *Arch Dis Child* 1996;75:51–6.
- Iacono G, Carroccio A, Cavataio F, Montalto G, Kazmierska I, Lorello D, et al. Gastroesophageal reflux and cow's milk allergy in infants: a prospective study. *J Allergy Clin Immunol* 1996;97:822–7.
- Nielsen RG, Bindslev-Jensen C, Kruse-Andersen S, Husby S. Severe gastroesophageal reflux disease and cow milk hypersensitivity in infants and children: disease association and evaluation of a new challenge procedure. *J Pediatr Gastroenterol Nutr* 2004;39:383–91.
- Clayden GS, Lawson JO. Investigation and management of long-standing chronic constipation in childhood. *Arch Dis Child* 1976;51:918–23.
- Simeone D, Miele E, Boccia G, Marino A, Troncione R, Staiano A. Prevalence of atopy in children with chronic constipation. *Arch Dis Child* 2008;93:1044–7.
- Daher S, Tahan S, Sole D, Naspitz CK, Da Silva Patricio FR, Neto UF, et al. Cow's milk protein intolerance and chronic constipation in children. *Pediatr Allergy Immunol* 2001;12:339–42.
- Iacono G, Cavataio F, Montalto G, Florena A, Tumminello M, Soresi M, et al. Intolerance of cow's milk and chronic constipation in children. *N Engl J Med* 1998;339:1100–4.
- Shah N, Lindley K, Milla P. Cow's milk and chronic constipation in children. *N Engl J Med* 1999;340:891–2.
- Misselwitz B, Pohl D, Fruhauf H, Fried M, Vavricka SR, Fox M. Lactose malabsorption and intolerance: pathogenesis, diagnosis and treatment. *United Eur Gastroenterol J* 2013;1:151–9.
- Levy Y, Levy A, Zangen T, Kornfeld L, Dalal I, Samul E, et al. Diagnostic clues for identification of nonorganic and organic causes of food refusal and poor feeding. *J Pediatr Gastroenterol Nutr* 2009;48:355–62.
- Rasinpera H, Savilahti E, Enattah NS, Kuokkanen M, Totterman N, Lindahl H, et al. A genetic test which can be used to diagnose adult-type hypolactasia in children. *Gut* 2004;53:1571–6.
- Ortolani C, Bruijnzeel-Koomen C, Bengtsson U, Bindslev-Jensen C, Bjorksten B, Host A, et al. Controversial aspects of adverse reactions to food. European Academy of Allergology and Clinical Immunology (EAACI) Reactions to Food Subcommittee. *Allergy* 1999;54:27–45.
- Cuomo R, Andreozzi P, Zito FP, Passananti V, De Carlo G, Sarnelli G. Irritable bowel syndrome and food interaction. *World J Gastroenterol* 2014;20:8837–45.
- Warner JO, Hathaway MJ. Allergic form of Meadow's syndrome (Munchausen by proxy). *Arch Dis Child* 1984;59:151–6.

# Prevention and Natural History of Food Allergy

SUSAN PRESCOTT | KATRINA ALLEN

## KEY POINTS

- The rise in food allergy is more rapid than genetic deviation would allow and the current consensus is that environmental factors integrally linked to the 'modern lifestyle' are likely to be key drivers of this phenomenon. The concept that these factors might be potentially modifiable is supported by studies demonstrating that food allergy is more common in developed than developing countries, and migrants appear to acquire the incident risk of allergy of their adopted country.
- There is emerging evidence that the early immunomodulatory effects of microbial exposure (including through indoor pet ownership and siblings) and nutritional patterns (including breast or formula feeding, exposure to allergenic solids and specific nutrient optimization such as vitamin D) are both important determinants of the risk of early-onset inflammatory diseases such as allergic disease, including food allergy.
- At present there is no clear evidence that prebiotics, probiotics or synbiotics prevent food allergy and mixed evidence regarding hydrolyzed formula. Although 'breast is best,' there are insufficient data currently to support the hypothesis that breastfeeding is protective.
- Food allergy is most commonly acquired during the first year of life, with peak incidence of 5% to 10% occurring at 1 year of age. The prevalence falls until late childhood, where it plateaus at about 3.5% through adulthood.
- Whereas milk and egg allergies are most frequently outgrown in childhood, peanut allergy most commonly remains a lifelong issue. Tree nut, fish and shellfish allergy are also much more likely to continue into adulthood than are egg and cow's milk allergy.

## Introduction

Allergic diseases have become the most common chronic diseases of childhood as part of a shifting profile of disease in modern societies. Even more recently, an epidemic of food allergy has emerged, particularly in the last 10 to 15 years. For good reason, we have described this as the 'second wave' of the allergy epidemic.<sup>1</sup> This phenomenon appears to still be evolving in many regions, and it is still unclear why it has occurred decades after the 'first wave' of asthma and respiratory allergy reached a peak in industrialized countries.

There is concern that this growing early predisposition for the allergic phenotype may portend a greater burden of

later-onset allergic diseases such as asthma and allergic rhinitis, and contribute to an escalating burden of inflammatory disease in this new generation.<sup>2</sup> The parallel increase in many other immune diseases and inflammatory noncommunicable diseases (NCDs) strongly suggests broader immunologic effects of modern risk factors on human health.<sup>2</sup> In this context, allergy may be regarded as the most common and earliest manifestation of the vulnerability of the immune system to modern environmental change. Strategies to improve early 'immune health' may therefore not only prevent allergic disease but also ultimately reduce the burden of other inflammatory diseases.

Because the rise in food allergy is more rapid than genetic deviation would allow, the current consensus is that environmental factors integrally linked to the 'modern lifestyle' are likely to be key drivers of this phenomenon. The concept that these factors might be potentially modifiable is supported by studies demonstrating that food allergy is more common in developed than developing countries, and migrants appear to acquire the incident risk of allergy of their adopted country.<sup>3</sup>

Factors associated with a 'modern lifestyle' include a myriad of changes to our level of public health including improved sanitation, secure water supplies (with associated decreased prevalence of *Helicobacter pylori* infection), widespread use of antibiotics and increasing rates of immunization, improved nutrition, decreased helminthic infestation, improved food quality (and presumably less microbial load in the food chain) as well as generally improved nutrition and associated obesity. These factors might work individually or in concert to effect a failure in the development of oral immune tolerance in the first year of life when development of IgE-mediated food allergy is most likely to occur. In addition there is likely to be at least some component of gene-environment interaction. That is to say, lifestyle factors may have a differential effect depending on genetic status of the individual.<sup>4</sup>

## The Importance and Timing of Early Intervention

This new epidemic of food allergy is most striking in preschool children, particularly in the first year of life. In high-income countries such as Australia, more than 20% of 1-year-old infants now have evidence of food sensitization and more than 10% now have challenge-proven IgE-mediated food allergy.<sup>5</sup> However it is not yet clear whether intervention measures need to be targeted prenatally or will be equally effective if administered postnatally. There is certainly evidence that an atopic predisposition has declared itself by the time of birth in at least some infants although, since food allergy phenotypes cannot be declared until postnatally, it is difficult to tease out whether interventions may still be effective in the postnatal period.

## ANTENATAL INTERVENTION

During pregnancy, there is close immunologic interaction between the mother and her offspring providing enormous opportunities to influence fetal immune development. The placenta and the fetus are vulnerable to a wide range of exogenous and endogenous maternal influences. Contrary to traditional concepts, human fetal T cells are responsive as early as 22 weeks' gestation.<sup>6</sup> We have shown emergent differences in immune function at birth in newborns destined to develop allergy<sup>7,8</sup> indicating that 'the scene is set' to some extent by birth. This highlights the importance of considering a broad range of immunomodulatory factors that may begin to have their effects much earlier in pregnancy than previously suspected. Notably, most of the environmental factors implicated in the development of allergic disease (including microbial exposure, dietary factors, cigarette smoke and other pollutants) have been shown to influence fetal immune function and contribute to an increased risk of subsequent allergic disease (reviewed in references 9 and 10). Moreover, there is also preliminary evidence that each of these has been associated with epigenetic effects, including activation or silencing of immune-related genes through epigenetic modifications.<sup>9,10</sup>

## POSTNATAL INTERVENTION

The early postnatal period also appears to be a critical period in the development of oral tolerance. Events in the gastrointestinal tract are vitally important for normal immune maturation. After birth we encounter a vast array of new antigenic proteins in relatively high 'doses'. Most of this foreign antigenic load is derived from colonizing commensal bacteria and food components. We have to learn very quickly to distinguish 'friend' from 'foe' on a large scale. To prevent inflammatory responses to largely harmless antigens, the gastrointestinal associated lymphoid tissue (GALT) has evolved complex mechanisms to promote tolerance as a default response (reviewed in reference 11). The human intestines harbor between 10 and 100 trillion resident microbiota, and this vast and complex ecosystem forms gradually over the first years of life. The collective genetic material of these bacteria (called the 'microbiome') is estimated to contain 150 times more genes than our human genome.<sup>12</sup> Through co-evolution and established 'mutualism' the microbiota play an essential role in homeostasis of multiple interconnected host metabolic and immune functions.<sup>13</sup>

The success of oral tolerance appears to depend on a number of oral exposures. Although the best known of these is breast milk, 'optimal' microbial diversity (still an ill-defined concept) and other dietary immunomodulatory factors including prebiotics (soluble fiber), fat soluble vitamins (including vitamin D) and polyunsaturated fatty acids (PUFAs) may all have important antiinflammatory effects (reviewed in reference 14). There is also some evidence to suggest that both the gastric acid milieu<sup>15</sup> and a possible 'window of opportunity' of optimal allergenic solids introduction between 4 and 6 months of age<sup>16,17</sup> are potential factors for oral tolerance development (see below).

## Immunomodulatory Strategies

There is now emerging evidence that the early immunomodulatory effects of microbial exposure (including through indoor pet ownership and siblings<sup>18</sup>) and nutritional patterns

(including breast or formula feeding, exposure to allergenic solids and specific nutrient optimization such as vitamin D) are both important determinants of the risk of early-onset inflammatory diseases such as allergic disease, including food allergy, although the interplay between these two sets of risk factors has not been formally evaluated.

## INFANT FEEDING

### Breast Milk

It is universally agreed that human milk should be the first and most important source of nutrition for the infant. It contains a vast array of bioactive factors including hormones, growth factors, neuropeptides and antiinflammatory and immunomodulatory agents that influence many physiologic systems and promote normal gut colonization for both short-term and long-term benefits.<sup>19</sup>

Allergens are normally secreted in breast milk and appear to be an important early source of exposure.<sup>20–22</sup> This may actually be important in initiating, maintaining and reinforcing normal tolerance to foods and even inhaled allergens.<sup>23,24</sup> While this has been demonstrated in animals, human evidence is more limited because randomized controlled trials are not possible. Systematic analysis of observational studies on the protective effect of breastfeeding has shown conflicting results, and many of the studies included were conducted decades ago when food allergy was uncommon and methods of assessment were limited.<sup>25</sup> An early review by Muraro et al<sup>26</sup> including 15 observational and 14 interventional studies concluded that breastfeeding for at least 4 months was associated with a reduced cumulative risk of cow's milk allergy in high-risk infants over 18 months of age. None of these studies was either randomized or prospective, and most systematic reviews since have failed to find a specific beneficial effect on food allergy.<sup>27,28</sup> Several cohort studies suggested that extended *exclusive* breastfeeding may increase the likelihood of sensitization or food allergy<sup>29,30</sup> in infants at high risk (reviewed in reference 28). This may relate to the timing of first complementary foods rather than the effects of breast milk per se (below). In this regard there is some, albeit limited, evidence that continued breastfeeding during the period when complementary foods are initiated may promote tolerance and have protective effects.<sup>31</sup> Even so, many expert bodies recommend that breastfeeding should continue while solids are introduced into the diet<sup>32,33</sup> although strong scientific evidence that it plays a role in the prevention of allergic disease is both lacking and unlikely to be available due to the unethical aspects of randomization trials that would need to include a 'no breastfeeding' arm.<sup>34</sup>

### Formula Feeding

There has been significant interest in the use of modified infant formulas – especially partially (PHF) and extensively hydrolyzed cow's milk formula (EHF) – for prevention of early childhood allergic disease. Intense expectations from families with a history of allergy seeking readily available primary prevention interventions have been responded to by industry with the development of a range of 'allergy prevention' formulae. Furthermore expert bodies have felt the need to provide recommendations regarding the use of formula for prevention of allergies. Current infant feeding guidelines in Europe,<sup>33</sup> the USA<sup>32</sup> and Australia all recommend that hydrolyzed formula can be considered as primary prevention therapy for allergic



diseases. These guidelines have been informed by the Cochrane review, the last update of which occurred in 2009.<sup>35</sup> This review supports the use of hydrolyzed formula for the prevention of allergy especially in high-risk infants who are unable to be completely breastfed although the authors themselves recommend further larger trials because of the methodological concerns and inconsistency of the findings of the studies included in the review. It should be noted that the findings of this review are heavily influenced by the reported benefits of PHF during the first six years of life demonstrated by the largest study of the review, the German Infant Nutritional Intervention (GINI) study. We have recently demonstrated that the Cochrane review suffers from small-study publication bias (scarcity of small negative studies),<sup>36</sup> and thus is likely to have overestimated the beneficial effect of PHF. Since the last update of this review, new evidence from a large intervention trial of high-risk infants (the Melbourne Atopic Cohort Study; MACS) has emerged challenging the effectiveness of PHF.<sup>37</sup> Additionally, while the GINI study outcomes up until the 6-year follow-up were promising, subsequent results have shown little evidence of an ongoing preventive effect between the ages of 7 and 10 years.<sup>38</sup> These more recent findings have also not yet been incorporated into the Cochrane review.<sup>35</sup> GINI and MACS are the two largest trials conducted to evaluate the effectiveness of PHF and both were industry supported through the provision of formulae. Interestingly, although there is significant debate around the role of PHF for the prevention of allergic disease,<sup>39,40</sup> both show similar results when the findings of the intention to treat analysis (ITT) are compared. Although both have substantial strengths, each has limitations. As it would be unethical to mandate one type of feeding – breastfeeding exclusively or fully over complementary formula feeding – it is not surprising that both studies are complicated by the impact of parental choice during the feeding intervention. Irrespective of the strengths and limitations of each study, even in the best case scenario, the number of high-risk children who would need to be fed with partially hydrolyzed formula to prevent one child from developing allergic disease in the first year of life is as high as 80<sup>41</sup> provided infant feeding patterns in GINI were replicated.

It is interesting that most recent recommendations from GINI suggest that casein-predominant EHF might be expected to have a more profound biologic effect because the formula is more extensively modified.<sup>42</sup> However most guidelines' recommendations are based on the fact that PHF is both cheaper and more palatable than EHF and therefore should be considered in place of EHF. Certainly in some countries EHF can only be medically prescribed, which significantly increases costs to the healthcare system. Added to the fact that a large number of infants would require treatment for a beneficial effect, the data suggest that recommendation of modified formula as a prevention measure for allergic disease may be premature.

### Timing of First Solids

Infant diet has long been thought to affect the risk of developing food allergies. In the 1960s infants were typically given solid foods in the first 3 months of life, but the 1970s saw the introduction of guidelines recommending delayed introduction of solids until after 4 months of age because of a perceived link between early introduction of gluten and celiac disease.<sup>43</sup> By the late 1990s, expert bodies had begun to recommend delaying solids until after 6 months of age, with further delay in the introduction of allergenic foods such as egg and nuts until at

least 2 years of age recommended for infants with a family history of allergy.<sup>44</sup> This did not, however, appear to have the desired effect of reducing the prevalence of food allergy and in 2008 lack of evidence of a protective effect led to the removal of advice to delay the introduction of any foods beyond 4 to 6 months of age with current guidelines outlined below.

A systematic review of the relationship between early introduction of solid foods, defined as introduction before 4 months of age, and allergy, conducted in 2005, identified only one cohort study investigating the relationship between early introduction of solids and food allergy.<sup>45</sup> The one included study, a birth cohort of 135 infants with atopic parents, found that early introduction of solid foods was associated with an increased risk of having reported symptoms of food allergy by 1 year of age. However, no difference was seen in food challenge confirmed allergy and there was also no difference in allergy to milk, egg or wheat, diagnosed by history and skin prick test, at 5 years of age.

In a recent large observational cohort study in Melbourne, Australia, we found no relationship between timing of introduction of solid foods and challenge-confirmed egg allergy at 1 year of age.<sup>17</sup> Solid foods in this cohort were predominantly introduced between 4 and 6 months of age, with only 4% introducing solids before age 4 months and 5% after 6 months, thus an effect of very early or late introduction of solids cannot be ruled out.

### Exposure to Allergenic Foods

Early intervention studies primarily investigated the impact of combined maternal and infant allergen avoidance on the prevalence of food sensitization and allergy among 'high-risk' infants with a family history of allergy. Not surprisingly, the initial reports from these studies showed lower rates of food sensitization and allergy in infants avoiding allergenic foods, indicating that allergic symptoms did not develop in the absence of exposure to these foods. However, protection did not appear to be maintained after the introduction of allergenic foods into the diet. Later follow-up of the study population in early childhood showed no reduction in the prevalence of food sensitization and allergy among those with early allergen avoidance, suggesting that these strategies were ineffective in promoting the development of tolerance.<sup>46</sup>

More recently, large observational studies have attempted to untangle the impact of timing of introduction of specific foods (such as peanut, egg or cow's milk) and development of allergy to those foods. The relationship between age at introduction of cow's milk products and cow's milk sensitization at age 2 was investigated in the Dutch birth cohort study described previously.<sup>47</sup> Although there was a trend for a decreased risk of sensitization with delayed introduction of cow's milk, this did not reach statistical significance. This analysis was also limited by the low percentage of the cohort for which sensitization data were available and by the lack of a clinically relevant outcome (symptomatic cow's milk allergy). A study of 12,234 newborn infants in Israel with 0.5% prevalence of IgE-mediated cow's milk allergy found that infants exposed to cow's milk in the first 14 days of life were less likely to be cow's milk allergic compared to those first exposed to cow's milk after 14 days,<sup>48</sup> although this was not controlled for family history of cow's milk allergy.

Two birth cohort studies designed to investigate risk factors for type 1 diabetes investigated the relationship between timing of food introduction and food sensitization or allergy.<sup>49,50</sup> Both

studies contained only infants with a family history or personal genetic risk of diabetes. Poole and colleagues found that introduction of wheat after 6 months of age was associated with an increased risk of parent-reported wheat allergy.<sup>49</sup> This finding was based on 16 children with parent-reported wheat allergy, only four of whom had detectable levels of wheat-specific IgE on blood testing. The authors also failed to control for a history of eczema in the child, which is likely to be associated with both dietary modifications and an increased risk of food sensitization. The second study found that introduction of egg after 10.5 months was associated with an increased risk of sensitization to egg at age 5.<sup>50</sup> The relevance of this finding is questionable as neither history of early allergic symptoms in the child nor family history of food allergy or eczema were considered in the analysis, both of which are likely to be important confounders. A recent Turkish study of 1015 infants found no association between age at introduction of egg and egg sensitization,<sup>51</sup> however the study was relatively underpowered with only 19 egg sensitized infants and, as for the above studies, did not use objectively confirmed food allergy as the outcome.

A landmark study by Du Toit et al compared the prevalence of peanut allergy among Jewish school children in Israel and the UK.<sup>52</sup> Although the study found that Israel had a lower prevalence of peanut allergy in school aged children and that in general peanuts were introduced earlier into the diet of infants in that country compared to the UK, the study design did not allow a direct link between age at first peanut consumption and peanut allergy on the individual level. Furthermore, the study was unable to eliminate other environmental factors as the cause of the differing prevalence of peanut allergy, a possibility that is consistent with the study finding a higher prevalence of other food allergies such as egg, tree nut and cow's milk allergy in the UK as well as a difference in prevalence of eczema, a co-associated condition. Interestingly, although there was a higher prevalence of egg allergy in the UK, this was not accompanied by a statistically significant difference in age at introduction of egg.

By contrast, the Healthnuts study in Australia found that, compared with introduction at 4 to 6 months, introducing egg into the diet later was associated with higher rates of egg allergy (adjusted odds ratio 3.4 [95% CI 1.8 to 6.5] for introduction after 12 months). Most interestingly, introduction of cooked egg such as scrambled, baked or fried was more protective than simply introducing egg in baked goods, with those who had been introduced to cooked egg at 4 to 6 months being five times less likely to develop egg allergy than those waiting until the normally recommended time of 10 to 12 months of age, even after adjusting for confounding factors. There was no protective effect among infants who were first introduced to baked egg in their diet between 4 and 6 months, presumably because a lower dose exposure does not provide protection. No other factors such as maternal food allergen avoidance or prolonged breastfeeding were associated with altered risk of egg allergy after adjusting for confounders.<sup>17</sup>

Together these studies provide reasonable evidence that delaying the introduction of solids in general or allergenic solids in particular is unlikely to reduce the risk of food allergy and may even paradoxically increase the risk. This is reflected in current guidelines in Australia, Europe and the USA, which no longer provide any recommendations on the best time to introduce these foods, citing a lack of evidence base for the prevention of food allergy.

TABLE 43-1

### Modified and Updated Summary of Data, with Regard to Infant Diet and the Primary Prevention of Food Allergy

Interventions	Summary
Pregnancy diet	No evidence of effectiveness
Lactation diet	Maternal antigen avoidance does not prevent atopic disease with the possible exception of atopic dermatitis. More data needed
Breastfeeding	Evidence exists that exclusive breastfeeding for at least 4 months vs feeding with cow's milk formula decreases cumulative incidence of atopic dermatitis and cow's milk allergy in the first 2 years of life Evidence exists that exclusive breastfeeding for at least 3 months protects against wheezing in early life, but there is not convincing evidence that exclusive breastfeeding in high-risk infants protects against allergic asthma beyond 6 years of age
Soy formula	No convincing evidence exists for the use of soy formula for allergy prevention
Protein hydrolyzate formula	Mixed evidence exists that atopic dermatitis may be delayed or prevented by the use of an extensively or partially hydrolyzed formula as compared to cow's milk formula in high-risk infants who are not breastfed exclusively for 4 to 6 months although more recent studies suggest a null effect. Not all hydrolyzed formulas have the same protective benefit. Cost must be considered in any decision-making process
Delayed introduction of solid foods	No convincing current evidence exists that delaying the introduction of solid food, including fish, egg and peanut, beyond 4 to 6 months protects against the development of allergic disease. There is emerging evidence that introduction of solids between 4 and 6 months may even be protective

Data from Greer FR, et al. *Pediatrics* 2008;121:183–91. Copyright © by the American Academy of Pediatrics, all rights reserved.

The most recent American Academy of Pediatrics guidelines (Table 43-1) state that there is insufficient evidence to recommend maternal dietary restrictions during pregnancy or breastfeeding. For infants at high risk of atopic disease, there is some evidence that exclusive breastfeeding for at least 4 months is protective against cow milk allergy in the first 2 years of life. However, there is no evidence that delaying the introduction of solids, including allergenic foods, until after 4 to 6 months is protective.<sup>32</sup>

## Restoring More Traditional PUFA Status

Declining consumption of antiinflammatory n-3 polyunsaturated fatty acids (PUFA) has been another significant dietary change with increasing urbanization. This has been replaced by increasing intakes of proinflammatory saturated fat and synthetic and n-6 PUFA. In many western diets, the ratio of n-6 to n-3 fatty acids ranges from approximately 20 to 30 : 1 instead of the traditional range of 1 to 2 : 1.<sup>53</sup> Changes in the diets of

Australian women are also reflected in the changing content of breast milk, which has similarly shown falling n-3 PUFA content and increasing n-6 PUFA levels.<sup>54</sup> This has led to falling intake of antiinflammatory n-3 PUFA in early life during the critical period of immune maturation.

Based on this, n-3 PUFA rich fish oils have been logical interventions for prevention and treatment of a number of inflammatory conditions. In one of the earliest randomized controlled trial (RCT) intervention studies for allergy prevention, we supplemented allergic women with fish oil from 20 weeks' gestation and demonstrated a range of immunomodulatory effects in their neonates.<sup>55-57</sup> We also saw preliminary evidence of reduced food (egg) sensitization and eczema severity at 1 year of age<sup>55</sup> although food allergy itself was not assessed. In a much larger subsequent RCT in 706 pregnant women, we again observed that fish oil supplementation significantly reduced egg sensitization at 12 months of age in high-risk infants.<sup>58</sup> Atopic eczema was also less common in the fish oil group. At the 3-year follow-up, eczema was still less common in the fish oil group although this was no longer statistically significant.<sup>59</sup> These observed reductions may still be important given the cost and burden of allergic disease. In a separate study, we also examined the effects of early postnatal fish oil supplementation in high-risk infants ( $N = 420$ ) for the first 6 months of life. We observed that increased infant n-3 PUFA levels were associated with lowered allergen-specific Th2 responses and elevated polyclonal Th1 responses.<sup>60</sup> Although n-3 PUFA levels at 6 months were associated with lower risk of eczema and recurrent wheeze, there was no effect of the intervention per se on the primary study outcomes.<sup>61</sup>

The results from these and other n-3 long-chain PUFA supplementation RCTs suggest that the dose, timing and duration of n-3 long-chain PUFA supplementation may influence sensitization and allergic disease outcomes. It has been proposed that a combination of measures to ensure more traditional PUFA status throughout the pre- and postnatal period, during important periods of immune development and maturation, may be most efficacious.<sup>62</sup> Notably, early interventions using fish oil for allergy prevention in early childhood<sup>60,61,63</sup> have also shown benefits for metabolic programming,<sup>64</sup> oxidative stress<sup>56</sup> and reducing cardiovascular risk.<sup>65,66</sup> Furthermore, in addition to immunomodulation<sup>55,60</sup> and allergy reduction,<sup>55,58</sup> we have also seen beneficial effects on aspects of neurodevelopment after both prenatal<sup>67</sup> and early postnatal<sup>68</sup> fish oil supplementation. In summary, restoring the higher n-3 PUFA levels seen in more traditional diets provides a clear example of an early immunomodulatory intervention with potential multisystem benefits.

## Vitamin D

The recent hypothesis that low vitamin D may increase the risk of food allergy<sup>69</sup> is supported by two lines of ecologic inquiry. First, there is a strong latitudinal prevalence gradient, with those countries further from the Equator (and thus lower ambient ultraviolet radiation) recording more admissions to hospital for food allergy-related events<sup>70</sup> and more prescriptions for epinephrine autoinjectors for the treatment of anaphylaxis.<sup>70,71</sup> These findings appear to be independent of longitude, physician density or socioeconomic status. Second, season of birth may play a role: children attending emergency departments in Boston with a food-related acute allergic reaction were more likely to be born in autumn/winter, when vitamin D levels reach

their nadir, than in spring/summer<sup>72</sup> and there are similar links to birth seasonality in the southern hemisphere.<sup>71</sup>

We have recently confirmed that Melbourne, the most southern major city in Australia, has the highest reported prevalence of documented infantile food allergy in the world, with more than 10% of a population sample of 1-year-old infants having challenge-proven IgE-mediated food allergy.<sup>5</sup> In a separate study, we have shown that, compared to the northern states, children residing in Australia's southern states are six times more likely to have peanut allergy at age 6 years and twice as likely to have egg allergy than those in the northern states.<sup>73</sup> We have also shown that the delayed introduction of egg, one of breastfed infants' richest sources of vitamin D, increases the risk of developing egg allergy by age 12 months by at least 5-fold.<sup>17</sup> Finally, increasing vitamin D insufficiency in Melbourne over the last 20 years,<sup>74</sup> paralleling the rise in food allergy, is supported by our own data showing that 20% of pregnant women are vitamin D insufficient.<sup>69,75</sup>

Using the Healthnuts population based study we found that infants of Australian-born parents, but not of parents born overseas, with vitamin D insufficiency ( $<50$  nM/L) were more likely to be peanut (aOR 11.51, 95% CI 2.01, 65.79,  $P = .006$ ) and/or egg (aOR 3.79, 95% CI 1.19, 12.08,  $P = .025$ ) allergic than those with adequate vitamin D levels independent of eczema status.<sup>76</sup> Among those with Australian-born parents, infants with vitamin D insufficiency were more likely to have multiple ( $\geq 2$ ) than single food allergies (aOR 10.48, 95% CI 1.60, 68.61 vs aOR 1.82, 95% CI 0.38, 8.77 respectively). These results provide the first direct evidence that vitamin D sufficiency may be an important protective factor for food allergy in the first year of life.

Vitamin D could influence the onset and resolution of food allergy via several plausible mechanisms. The vitamin D receptor is widely expressed in the immune system including T cells, in particular promoting the expression of IL-10 secreting T regulatory cells crucial to maintaining immune tolerance<sup>77</sup> and, potentially, playing a key role in the induction of tolerance in food allergic individuals.<sup>78</sup> Vitamin D metabolites also contribute to innate epithelial defenses by stimulating production of antimicrobial proteins such as cathelicidins<sup>79,80</sup> and defensins.<sup>81</sup> Randomized controlled trials assessing the potential role of vitamin D in the prevention of food allergy are urgently needed.

## Modulation of the Maternal and Infant Microbiome

Changes in the microbiota, induced by a range of modern environmental factors and dietary patterns, are implicated in the rising predisposition to a range of inflammatory and metabolic disorders.<sup>82</sup> This underscores the likely importance of strategies that improve gut homeostasis and the microbiome as part of disease prevention strategies.<sup>2,83</sup> A low-fiber, high-fat 'western' diet is associated with adverse changes in gut microbiome, altered gut barrier function,<sup>84</sup> increased systemic endotoxin and low-grade Toll-like receptor (TLR)-mediated systemic inflammation with increased C-reactive protein (CRP), IL-1 $\beta$ , tumor necrosis factor (TNF) and IL-6. Animal models provide clear evidence that the gut microbiota modulate immune programming, and that manipulation of the microbiome can prevent not only allergic disease<sup>85</sup> and autoimmune



phenomena, but also the risk of obesity, cardiovascular and metabolic disease through well-described metabolic effects (reviewed in references 2 and 82).

Early microbial diversity, beginning in utero, is a major driving factor<sup>86,87</sup> in the normal maturation of both Th1<sup>7,88</sup> and T<sub>REG</sub> function<sup>89,90</sup> and suppressing the propensity for Th2 allergic responses in early childhood.<sup>8</sup> Epidemiologic studies also indicate that a 'high microbial environment' during pregnancy affords greater protection from allergy than postnatal exposure alone.<sup>91</sup> Thus, while continued postnatal microbial exposure is critical for immune maturation and allergy protection, the role of the antenatal period must not be overlooked or underestimated.

Contrary to long-standing assumptions, the womb is not 'sterile' after all. In normal healthy pregnancies, microbes can be detected in amniotic fluid, placental and fetal membranes, cord blood and meconium, providing a 'pioneer' microbiome.<sup>92</sup> In murine studies, labeled bacteria are transferred from mother to fetus during pregnancy.<sup>93</sup> It is increasingly clear that the maternal microbial environment during pregnancy is also important in early immune programming, providing an initial antenatal source of immunostimulation.<sup>82,94</sup>

So far, most allergy prevention studies aimed at improving early colonization have focused on improving postnatal colonization in the infant, rather than on influencing immune development during fetal life. The first attempts to increase gut microbial diversity for allergy prevention were with probiotic supplements.<sup>95</sup> Although some of these studies used probiotics in pregnancy, most only used probiotics the last 2 to 4 weeks of gestation with the dominant goal of influencing infant colonization in the postnatal period.<sup>83</sup> The only RCT ( $N = 241$ ) to use probiotics earlier than this for allergy prevention (but still for only 8 weeks in late pregnancy) significantly reduced infant eczema.<sup>96</sup>

Collectively there have now been more than 20 studies to examine the effects of probiotics in allergy prevention. Although the findings have been variable, the most consistent finding has been protection from early allergic outcomes such as eczema (reviewed in references 83 and 97). Several meta-analyses have now been performed, each generally concluding that probiotics reduce the risk of eczema but have no consistent effects on food allergy or other allergic outcomes.<sup>97–101</sup> The most recent meta-analysis<sup>97</sup> included 13 prevention studies and found that probiotic treatment reduced the incidence of eczema by 21% (RR 0.79, 95% CI 0.71–0.88). This effect was still evident when the analysis was restricted to patients with IgE-associated eczema (RR 0.80, 95% CI 0.66–0.96).

We speculate that, given the likely role of the maternal microbiome in pregnancy for both immune and metabolic homeostasis,<sup>102</sup> it is logical to investigate the effects of the combination of pre- and probiotics (synbiotics) much earlier in pregnancy, at a time when fetal responses are first initiated.<sup>94</sup> Providing some support for this, a recent large-scale observational study of 40,614 Norwegian mother-child pairs found that probiotic milk consumption in pregnancy (assessed at 22 weeks' gestation) was associated with a reduced incidence of atopic eczema and allergic rhinoconjunctivitis at 3 years of age.<sup>103</sup> To our knowledge the only RCT ( $N = 256$ ) to use probiotics from the first trimester did not assess immune effects or allergic outcomes but reported a number of metabolic benefits for both the mother and the fetus.<sup>104</sup> Even in the final weeks of

pregnancy, probiotics have been shown to significantly alter expression of innate TLR-related genes in the placenta and in the fetal gut.<sup>93</sup> We have also shown changes in cord blood serum cytokines.<sup>105</sup>

There is now growing interest in using 'prebiotic' fiber to promote favorable colonization and reduce inflammation. In humans, prebiotic fiber selectively stimulates growth of beneficial gut microbiota, particularly bifidobacteria but also lactobacilli,<sup>106</sup> in a dose dependent manner. Prebiotic fermentation products, short-chain fatty acids (SCFA), have direct anti-inflammatory effects.<sup>107</sup> This promotes intestinal integrity and reduces systemic endotoxin and antigenic load in experimental models. Acetate, butyrate and propionate are among the most abundant SCFA and play a critical role in local and systemic metabolic function and stimulating regulatory immune responses.<sup>84</sup> Accordingly, human randomized controlled trials using prebiotics have shown some beneficial effects on the microbiome and immune function with reduced systemic inflammation, and metabolic dysregulation.<sup>108</sup>

There are now several studies in the postnatal period showing beneficial effects on early colonization and a reduction of eczema with prebiotic supplementation<sup>106,109</sup> although effects on the prevention of food allergy have been disappointing, which is somewhat surprising since eczema and food allergy so frequently co-associate in the first year of life. The first major study to investigate the effect of prebiotics on allergy prevention used a mixture of galactooligosaccharide/fructooligosaccharide prebiotics during the first 6 months of life in formula-fed infants at high risk of atopy.<sup>106</sup> At 6 months of age the rate of eczema was significantly lower in the treatment group (9.8%; 95% CI 5.4–17.1%) compared with the placebo group (23.1%; 95% CI 16.0–32.1%). By 2 years of age, the cumulative incidence of eczema, recurrent wheeze and allergic urticaria were all significantly lower in the treatment group compared with the control group, although the follow-up was limited to approximately half of the original population.<sup>110</sup> In a similar study of formula-fed infants at low risk of allergy, there was also a significant reduction in eczema in those randomized to a formula containing prebiotics (neutral oligosaccharides and pectin-derived acidic oligosaccharides) compared with regular formula.<sup>109</sup> The results of other studies are awaited before recommendations can be considered.

Studies of prebiotic oligosaccharides in pregnancy are also still limited. In animal models, probiotics in pregnancy alter colonization and metabolic homeostasis<sup>111</sup> and reduce eczema-like inflammation in offspring.<sup>112</sup> Observational studies in human pregnancy show that high-fiber diets are associated with a reduced risk of pre-eclampsia and dyslipidemia. To our knowledge, the only RCT to use prebiotics in pregnancy was too small ( $N = 48$ ) to reliably assess immune effects on the fetus or clinical effects, but did achieve favorable changes in maternal gut microbiota.<sup>113</sup> This highlights the need for human studies of prebiotics in pregnancy.

While the use of a prebiotic alone may be effective,<sup>106</sup> the combination with bifidobacteria and lactobacilli probiotics is a logical strategy to assist in favorable diversity, already showing some benefit in the postnatal period.<sup>114</sup> Prebiotics promote microbial diversity by stimulating the growth of commensals. Prebiotics also provide the substrate for anti-inflammatory short-chain fatty acid production by bacteria. This is likely to have more global effects on gut homeostasis than only adding



one or two probiotic strains into the vast and complex ecosystem of the gut.

In summary, at present there is no clear evidence that prebiotics, probiotics or synbiotics prevent food allergy.

## Targeting and Individualizing Prevention Strategies – Considering Phenotypic, Environmental and Genotypic Risk

The effectiveness of any ‘preventive’ intervention is likely to vary with both genetic and environmental factors, including maternal allergic status, which may also have direct effects on the immunologic milieu during pregnancy and lactation. Just as concepts of individualized ‘precision medicine’ are being explored for disease treatment, prevention strategies may also ultimately need to be tailored according to the context, conditions and other factors determining risk. This requires a better understanding of both the genetic and environmental determinants of allergic risk, which are likely to be extremely variable and complex, and raises a series of issues that will become increasingly relevant as technologies evolve, including how to target interventions, how to identify specific groups at risk and how to refine strategies according to the level of risk.

At present there are no good early markers of genetic risk apart from ‘family history’, which remains the only predictor of allergic disease in use. This is crude and imperfect with variable specificity (48–67%) and sensitivity (22–72%) and a positive predictive value generally less than 40%.<sup>115–117</sup> Because there are many and diverse genetic determinants of allergy, predicting risk through genotyping is not yet possible. In the meantime there have been attempts to identify early predictive biologic markers. Currently none of these has any established predictive value.<sup>118</sup>

A better understanding of the genetic predispositions existing to food allergy will lead to the determination of whether a rise in food allergy is occurring asymmetrically between high-risk and low-risk groups. There is evidence that Asian populations may be more susceptible to allergic disease when living in ‘westernized’ environments.<sup>119,120</sup> Earlier studies of respiratory disease observed that both allergic symptoms and sensitization were more common in Asian Australians than in non-Asian Australians.<sup>119</sup> Rates were also higher in Australian-born Asians than in Asian immigrants, in whom the prevalence increased with length of stay in Australia.<sup>119</sup> Recently, the Healthnuts study (2011) found a higher rate of food-sensitized eczema among children of Asian descent.<sup>121</sup> Interestingly, on examination of risk factors for eczema development (a closely associated infantile allergic disease) the study found that Asian children were not only more likely to have eczema than their non-Asian counterparts but that their parents were less likely to have allergic disease than non-Asian parents. This was particularly so for Asian parents who had migrated to Australia less than five years previously, suggesting a strong gene-environment interaction even over and above that of a migrational generational effect.<sup>122</sup> More recent studies have similarly noted that non-white races are more susceptible to food allergy. In the USA, the 2007 National Health Interview Survey found that non-Hispanic children had higher rates of reported food allergy compared with Hispanic children.<sup>123</sup> Asian populations in particular

are also highly susceptible to food allergy,<sup>120</sup> suggesting a strong genetic propensity that is amplified by a western environment. This is consistent with earlier work indicating evolutionary differences in genetic polymorphisms affecting candidate genes.

Finally, eczema does appear to be an important risk factor for the development of food allergic disease: up to 50% of infants with moderately severe early-onset eczema (within the first 3 months) develop challenge-proven food allergy by age 1 year.<sup>124</sup> This population-based observation has been noted in clinical populations and suggests that eczema genes (such as *filaggrin*, *FLG*) may be important determinants of food allergic disease. A multisite study of peanut allergy found that *FLG* null mutations were associated with a significantly increased risk of peanut allergy;<sup>125</sup> however, history of eczema and sensitization status was not available for all infants, therefore the impact of *FLG* on these outcomes could not be assessed independently of food allergy. In the Healthnuts study we found that *FLG* null mutations were associated with food sensitization (but not food allergy over and above that risk) independent of eczema status. This suggests that there could be a different pathogenesis for food sensitization and food allergy. That is, the epidermal barrier dysfunction due to filaggrin deficiency might cause food sensitization regardless of clinical eczema status, but filaggrin-induced skin barrier dysfunction might not play a further role in the progression to food allergy from sensitization. These results provide support for the dual allergen hypothesis proposed by Gideon Lack.<sup>126</sup> Expanding on this hypothesis, filaggrin deficiency might provide a mechanism for the development of sensitization, but a second factor (or factors), either environmental or genetic (or both), may be important for converting food sensitized infants to food allergic status.

## Natural History of Food Allergy

Food allergy is most commonly acquired during the first year of life, with peak incidence of 5% to 10% occurring at 1 year of age. The prevalence falls until late childhood, where it plateaus at about 3.5% through adulthood. The prevalence of perceived, but unconfirmed, food allergy or food intolerance is as high as 25%.<sup>127</sup>

It appears that prevalence of food allergies has been increasing over recent years. In 2003, Sicherer and colleagues<sup>128</sup> reported that the rate of allergy to peanut or tree nut, or both, in children, rose from 0.6% to 1.2% between 1997 and 2003, primarily as a result of an increase in the reported allergy to peanuts from 0.4% to 0.8% over this period. In 2004, the overall prevalence of food allergy in the USA was reported as 6% in young children and 3.7% in adults.<sup>129</sup> The prevalence of milk allergy in children vs adults was 2.5% vs 0.3%, egg 1.3% vs 0.2%, peanut 0.8% vs 0.6%, tree nut 0.2% vs 0.5%, fish 0.1% vs 0.4% and shellfish 0.1% vs 2.0%. Prevalence of sensitization to foods peaked at 10% at 1 year, declining to 3% at 6 years of age. Egg and milk IgE were the most common positives, followed by wheat and soy; no clinical confirmation of food allergy was reported.

In a Danish study by Host and Halken,<sup>130</sup> 1,749 children were followed prospectively from birth to the age of 3 years. Milk allergy was suspected in 117 children (6.7%) and confirmed by milk elimination and oral challenge in 39 (2.2%), with more than half having documented IgE-mediated disease. In a study from the Isle of Wight,<sup>131</sup> all children born over a 1-year period

( $N = 1,456$ ) were followed for the development of peanut and tree nut allergy until 4 years of age. Fifteen (1.2%) of the 981 skin-tested children were found to be sensitized to peanuts or tree nuts. In a large German study,<sup>132</sup> radioallergosorbent tests (RASTs) were performed yearly to the age of 6 years on a birth cohort of 4,082 children.

It has long been established that, whereas milk and egg allergies are most frequently outgrown in childhood, peanut allergy most commonly remains a lifelong issue. Tree nut, fish and shellfish allergy are also much more likely to continue into adulthood than are egg and cow's milk allergy. Recent studies suggest that milk<sup>133</sup> and egg allergy<sup>134</sup> are more persistent than they were 15 years ago. In addition, the eventual tolerance or persistence of allergy may be predictable by degree of positivity of allergy tests or concomitant allergic conditions. Cow's milk and egg allergy in particular are more likely to resolve early although the first data to look longitudinally<sup>134</sup> found that up to 60% of children presenting to a tertiary center with food allergy had developed tolerance by 16 years of age. However this study was limited because it followed the self-fulfilling clinical prophesy that those with a sustained elevated skin prick test were unlikely to have developed oral tolerance and therefore were not offered oral food challenges – the most objective way to formally diagnose tolerance. Recently Peters et al followed a population-based longitudinal cohort and found that 47% of infants with challenge-proven food allergy at 12 months had resolution by age 2 years.<sup>135</sup> This study was unique in that oral food challenges were systematically undertaken in all infants with a positive skin prick test (SPT), irrespective of how large the wheal size, minimizing underdiagnosis of tolerance. Furthermore, egg allergy was subphenotyped by undertaking baked egg challenges in addition to raw egg allergy challenges. The study found that those with baked egg tolerance (80% of egg allergic infants at age 12 months) were three times more likely to develop tolerance by age 2 years than those who were baked egg allergic. This study was supported by a similarly designed study from the CoFAR collaboration although the latter assessed the rate of egg allergy resolution in a clinic cohort of older children.<sup>136</sup>

In addition to baked egg allergy status described by Peters et al,<sup>135</sup> predictors of egg allergy remission in the CoFAR study<sup>136</sup> included initial reaction characteristics (isolated urticaria/angioedema vs other presentations), baseline egg-specific IgE level, egg SPT wheal size, eczema severity and IgG4 and IL-4 responses. Further studies assessing prognostic implications for food allergy should therefore carefully subphenotype at baseline using clear and valid criteria (including baked egg challenges for egg allergy) as well as ensuring that analysis of tolerance is made using the gold standard outcome, oral food challenge.

In addition to a lower general prevalence, peanut and tree nut allergies appear to have a lower rate of resolution than either egg or cow's milk allergies. Again very few longitudinal data exist and only peanut data from clinic recruited cohorts are available.<sup>137</sup> Ho and colleagues<sup>137</sup> demonstrated that peanut SPT wheal of 6 mm or greater (hazard ratio 2.74, 95% CI 1.13–3.79) and specific IgE  $>3$  kU<sub>A</sub>/L (hazard ratio 2.74, 95% CI 1.13–6.61) were predictive of persistent peanut allergy. As per the Savage report,<sup>134</sup> challenges in this cohort were only initiated if SPT wheal sizes fell below a threshold consistent with the 95% PPV for allergy diagnosis.<sup>137</sup> Information about peanut allergy resolution using systematic challenges is urgently needed as are any longitudinal data regarding tree nut allergy resolution.

Although it had generally been thought that once food allergies have resolved they are unlikely to recur, the unsettling recurrence of peanut<sup>138</sup> and fish<sup>139</sup> allergy has been reported in patients with previously negative food challenges following a history of earlier allergy. Further to this point, in 2003, Fleischer and colleagues<sup>140</sup> reported that in a group of 84 patients with peanut allergy, 55% of those with peanut IgE levels  $<5$  kU<sub>A</sub>/L were able to pass peanut challenges, while 63% of those with levels  $<2$  kU<sub>A</sub>/L were able to tolerate peanuts. Recurrence of the peanut allergy was reported in 2 patients, both of whom did not ingest peanuts regularly after they had passed their challenges. Two years later,<sup>141</sup> this group also reported that 9% of patients with tree nut allergy could ultimately pass a double-blind, placebo-controlled food challenge to tree nut.

It seems that there are likely different phenotypes of food allergy, whose natural history depends not only on the amount of IgE measured or concomitant allergic conditions but also the specific epitope against which the IgE is directed. Vila and colleagues<sup>142</sup> demonstrated that the specific cow's milk IgE from patients with persistent cow's milk allergy is more likely to bind to the linear (sequential) epitopes of  $\alpha$ 1- and  $\beta$ -casein as compared to higher levels of IgE to the conformational (native) epitopes in children who had lost their clinical sensitivity to cow's milk as documented by oral food challenge.

Lately, the phenomenon that some children with egg allergy can tolerate heated egg (egg in baked goods) but not whole egg has been studied. Lemon-Mulé and colleagues<sup>143</sup> recently reported that a majority of egg allergic children could tolerate heated egg, particularly those with smaller SPT and egg-specific IgE levels. Furthermore, continued ingestion of heated egg led to decreased skin test wheal diameter, ovalbumin-specific IgE and ovalbumin- and ovomucoid-specific IgG4. The authors noted that these immunologic changes parallel those that one would expect to see in clinical tolerance. The same group earlier reported similar immunologic findings in milk allergic children who could tolerate heated milk products.<sup>144</sup> Seventy five percent of the milk allergic children were able to tolerate heated milk. The authors postulated that this tolerance could be due to the loss of conformational epitopes that comes from heating. There is now an evolving practice of offering baked cow's milk or baked egg oral food challenges to infants and children with cow's milk and egg allergy respectively with the aim of providing a more liberated diet and the potential to induce tolerance to the uncooked food allergen.<sup>145,146</sup>

## Conclusions and Future Directions

The modern environment, with its compound risk factors for development of allergy, presents many challenges. Strategies to effectively overcome these risk factors present even greater challenges, particularly as many risk factors are driven by wider social, cultural and economic factors and cannot necessarily be addressed by individual efforts. If the hygiene hypothesis is found to be central to the rise of both atopy in general and food allergy more specifically, this effect might be expressed through a delayed generational effect and the impact of maternal epigenetic modification on fetal priming of the immune system.

Countries with a westernized lifestyle appear to have the highest rates of allergic disease, and allergies are less common in developing countries. To date there has been little information on these differences or why they might be occurring. Emerging evidence suggests that changes in the environment

related to a western lifestyle and to economic development are the most important factors causing the rise in allergic disease.<sup>1</sup> In particular, improved hygiene, less exposure to microbial organisms, changes in diet (eating less fish and vegetables), less exposure to sunlight (reduced UV and therefore reduced vitamin D), and possibly increased use of antibiotics are thought

to be the main factors contributing specifically to the rise in food allergy.

The complete reference list can be found on the companion Expert Consult website at <http://www.expertconsult.inkling.com>.

## KEY REFERENCES

1. Prescott SL, Allen KJ. Food allergy: riding the second wave of the allergy epidemic. *Pediatr Allergy Immunol* 2011;22:155–60.
2. Prescott SL. Early-life environmental determinants of allergic diseases and the wider pandemic of inflammatory noncommunicable diseases. *J Allergy Clin Immunol* 2013;131:23–30.
16. Prescott SL, Smith P, Tang MLK, Palmer DJ, Sinn J, Huntley SJ, et al. The importance of early complementary feeding in the development of oral tolerance: concerns and controversies. *Pediatr Allergy Immunol* 2008;19:375–80.
25. Grimshaw KE, Allen K, Edwards CA, Beyer K, Boulay A, van der Aa LB, et al. Infant feeding and allergy prevention: a review of current knowledge and recommendations. A EuroPrevall state of the art paper. *Allergy* 2009;64:1407–16.
27. Kramer MS, Kakuma R. The optimal duration of exclusive breastfeeding: a systematic review. *Adv Exp Med Biol* 2004;554:63–77.
33. Agostoni C, Decsi T, Fewtrell M, Goulet O, Kolacek S, Koletzko B, et al. Complementary feeding: a commentary by the ESPGHAN Committee on Nutrition. *J Pediatr Gastroenterol Nutr* 2008;46:99–110.
34. Matheson MC, Allen KJ, Tang ML. Understanding the evidence for and against the role of breastfeeding in allergy prevention. *Clin Exp Allergy* 2012;42:827–51.
44. American Academy of Pediatrics. Committee on Nutrition. Hypoallergenic infant formulas. *Pediatrics* 2000;106(2 Pt 1):346–9.
69. Vuillermin PJ, Ponsonby AL, Kemp AS, Allen KJ. Potential links between the emerging risk factors for food allergy and vitamin D status. *Clin Exp Allergy* 2013;43:599–607.
84. Maslowski KM, Mackay CR. Diet, gut microbiota and immune responses. *Nat Immunol* 2011;12:5–9.

## REFERENCES

- Prescott SL, Allen KJ. Food allergy: riding the second wave of the allergy epidemic. *Pediatr Allergy Immunol* 2011;22:155–60.
- Prescott SL. Early-life environmental determinants of allergic diseases and the wider pandemic of inflammatory noncommunicable diseases. *J Allergy Clin Immunol* 2013;131:23–30.
- Cataldo F, Accomando S, Fragapane ML, Montaperto D, SIGENP and GLNBI Working Groups on Food Intolerances. Are food intolerances and allergies increasing in immigrant children coming from developing countries? *Pediatr Allergy Immunol* 2006;17:364–9.
- Dempfle A, Scherag A, Hein R, Beckmann L, Chang-Claude J, Schafer H. Gene-environment interactions for complex traits: definitions, methodological requirements and challenges. *Eur J Hum Genet* 2008;16:1164–72.
- Osborne NJ, Koplin JJ, Martin PE, Gurrin LC, Lowe AJ, Matheson MC, et al. Prevalence of challenge-proven IgE-mediated food allergy using population-based sampling and predetermined challenge criteria in infants. *J Allergy Clin Immunol* 2011;127:668–76. e1–2.
- Jones A, Miles E, Warner J, Colwell B, Bryant T, Warner J. Fetal peripheral blood mononuclear cell proliferative responses to mitogenic and allergenic stimuli during gestation. *Pediatr Allergy Immunol* 1996;7:109–16.
- Tulic MK, Hodder M, Forsberg A, McCarthy S, Richman T, D'Vaz N, et al. Differences in innate immune function between allergic and nonallergic children: new insights into immune ontogeny. *J Allergy Clin Immunol* 2011;127:470–8. e1.
- Prescott S, Macaubas C, Holt B, Smallacombe T, Loh R, Sly P, et al. Transplacental priming of the human immune system to environmental allergens: universal skewing of initial T-cell responses towards Th-2 cytokine profile. *J Immunol* 1998;160:4730–7.
- Martino D, Prescott SL. Epigenetics and prenatal influences on asthma and allergic airways disease. *Chest* 2011;139:640–7.
- Martino DJ, Prescott SL. Progress in understanding the epigenetic basis for immune development, immune function, and the rising incidence of allergic disease. *Curr Allergy Asthma Rep* 2013;13:85–92.
- Tsuji NM, Kosaka A. Oral tolerance: intestinal homeostasis and antigen-specific regulatory T cells. *Trends Immunol* 2008;29:532–40.
- Qin J, Li R, Raes J, Arumugam M, Burgdorf KS, Manichanh C, et al. A human gut microbial gene catalogue established by metagenomic sequencing. *Nature* 2010;464:59–65.
- McFall-Ngai M, Hadfield MG, Bosch TC, Carey HV, Domazet-Lozo T, Douglas AE, et al. Animals in a bacterial world, a new imperative for the life sciences. *Proc Natl Acad Sci U S A* 2013;110:3229–36.
- West CE, Videky D, Prescott SL. Role of diet in the development of immune tolerance in the context of allergic disease. *Curr Opin Pediatr* 2010;22:635–41.
- Pali-Scholl I, Jensen-Jarolim E. Anti-acid medication as a risk factor for food allergy. *Allergy* 2011;66:469–77.
- Prescott SL, Smith P, Tang MLK, Palmer DJ, Sinn J, Huntley SJ, et al. The importance of early complementary feeding in the development of oral tolerance: concerns and controversies. *Pediatr Allergy Immunol* 2008;19:375–80.
- Koplin JJ, Osborne NJ, Wake M, Martin PE, Gurrin LC, Robinson MN, et al. Can early introduction of egg prevent egg allergy in infants? A population-based study. *J Allergy Clin Immunol* 2010;126:807–13.
- Koplin JJ, Dharmage SC, Ponsonby AL, Tang ML, Lowe AJ, Gurrin LC, et al. Environmental and demographic risk factors for egg allergy in a population-based study of infants. *Allergy* 2012;67:1415–22.
- Goldman AS. Modulation of the gastrointestinal tract of infants by human milk. Interfaces and interactions. An evolutionary perspective. *J Nutr* 2000;130(2S Suppl.):426S–31S.
- Vance GH, Lewis SA, Grimshaw KE, Wood PJ, Briggs RA, Thornton CA, et al. Exposure of the fetus and infant to hens' egg ovalbumin via the placenta and breast milk in relation to maternal intake of dietary egg. *Clin Exp Allergy* 2005;35:1318–26.
- Palmer DJ, Gold MS, Makrides M. Effect of cooked and raw egg consumption on ovalbumin content of human milk: a randomized, double-blind, cross-over trial. *Clin Exp Allergy* 2005;35:173–8.
- Macchiaverni P, Rekima A, Turfkruyer M, Mascarelli L, Airouche S, Moingeon P, et al. Respiratory allergen from house dust mite is present in human milk and primes for allergic sensitization in a mouse model of asthma. *Allergy* 2014;69:395–8.
- Verhassel V, Milcent V, Cazareth J, Kanda A, Fleury S, Dombrowicz D, et al. Breast milk-mediated transfer of an antigen induces tolerance and protection from allergic asthma. *Nat Med* 2008;14:170–5.
- Yamamoto T, Tsubota Y, Kodama T, Kageyama-Yahara N, Kadowaki M. Oral tolerance induced by transfer of food antigens via breast milk of allergic mothers prevents offspring from developing allergic symptoms in a mouse food allergy model. *Clin Dev Immunol* 2012;2012:721085.
- Grimshaw KE, Allen K, Edwards CA, Beyer K, Boulay A, van der Aa LB, et al. Infant feeding and allergy prevention: a review of current knowledge and recommendations. A EuroPrevall state of the art paper. *Allergy* 2009;64:1407–16.
- Muraro A, Dreborg S, Halken S, Host A, Niggemann B, Aalberse R, et al. Dietary prevention of allergic diseases in infants and small children. Part III: critical review of published peer-reviewed observational and interventional studies and final recommendations. *Pediatr Allergy Immunol* 2004;15:291–307.
- Kramer MS, Kakuma R. The optimal duration of exclusive breastfeeding: a systematic review. *Adv Exp Med Biol* 2004;554:63–77.
- de Silva D, Geromi M, Halken S, Host A, Panesar SS, Muraro A, et al. Primary prevention of food allergy in children and adults: systematic review. *Allergy* 2014;69:581–9.
- Saarinen KM, Juntunen-Backman K, Jarvenpaa AL, Kuitunen P, Lope L, Renlund M, et al. Supplementary feeding in maternity hospitals and the risk of cow's milk allergy: a prospective study of 6209 infants. *J Allergy Clin Immunol* 1999;104(2 Pt 1):457–61.
- Wetzig H, Schulz R, Diez U, Herbarth O, Viehweg B, Borte M. Associations between duration of breast-feeding, sensitization to hens' eggs and eczema infantum in one and two year old children at high risk of atopy. *Int J Hyg Environ Health* 2000;203:17–21.
- Grimshaw KE, Maskell J, Oliver EM, Morris RC, Foote KD, Mills EN, et al. Introduction of complementary foods and the relationship to food allergy. *Pediatrics* 2013;132:e1529–38.
- Greer FR, Sicherer SH, Burks AW. Effects of early nutritional interventions on the development of atopic disease in infants and children: the role of maternal dietary restriction, breastfeeding, timing of introduction of complementary foods, and hydrolyzed formulas. *Pediatrics* 2008;121:183–91.
- Agostoni C, Decsi T, Fewtrell M, Goulet O, Kolacek S, Koletzko B, et al. Complementary feeding: a commentary by the ESPGHAN Committee on Nutrition. *J Pediatr Gastroenterol Nutr* 2008;46:99–110.
- Matheson MC, Allen KJ, Tang ML. Understanding the evidence for and against the role of breastfeeding in allergy prevention. *Clin Exp Allergy* 2012;42:827–51.
- Osborn DA, Sinn J. Formulas containing hydrolysed protein for prevention of allergy and food intolerance in infants. *Cochrane Database Syst Rev* 2006;4:CD003664.
- Lowe AJ, Dharmage SC, Allen KJ, Tang ML, Hill DJ. The role of partially hydrolyzed whey formula for the prevention of allergic disease: evidence and gaps. *Expert Rev Clin Immunol* 2013;9:31–41.
- Lowe AJ, Hosking CS, Bennett CM, Allen KJ, Axelrad C, Carlin JB, et al. Effect of a partially hydrolyzed whey infant formula at weaning on risk of allergic disease in high-risk children: a randomized controlled trial. *J Allergy Clin Immunol* 2011;128:360–5. e4.
- von Berg A, Filipiak-Pittroff B, Kramer U, Hoffmann B, Link E, Beckmann C, et al. Allergies in high-risk schoolchildren after early intervention with cow's milk protein hydrolysates: 10-year results from the German Infant Nutritional Intervention (GINI) study. *J Allergy Clin Immunol* 2013;131:1565–73.
- Brand PL. Partially hydrolysed whey and soy-based infant formulas did not prevent allergic disease in high-risk children. *Arch Dis Child Educ Pract Ed* 2012;97:120.
- Arshad SH. Primary prevention of allergy by using protein hydrolysate: an achievable objective? *J Allergy Clin Immunol* 2013;131:1574–5.
- von Berg A, Koletzko S, Filipiak-Pittroff B, Laubereau B, Grubl A, Wichmann HE, et al. Certain hydrolyzed formulas reduce the incidence of atopic dermatitis but not that of asthma: three-year results of the German Infant Nutritional Intervention Study. *J Allergy Clin Immunol* 2007;119:718–25.
- von Berg A, Koletzko S, Filipiak-Pittroff B, Heinrich J, Bauer CP, Kramer U, et al. The German Infant Nutritional Intervention (GINI) study and formulation issues. Reply. *J Allergy Clin Immunol* 2013;132:770–1.
- Challacombe DN. The incidence of coeliac disease and early weaning. *Arch Dis Child* 1983;58:326.
- American Academy of Pediatrics. Committee on Nutrition. Hypoallergenic infant formulas. *Pediatrics* 2000;106(2 Pt 1):346–9.
- Tarini BA, Carroll AE, Sox CM, Christakis DA. Systematic review of the relationship between



- early introduction of solid foods to infants and the development of allergic disease. *Arch Pediatr Adolesc Med* 2006;160:502-7.
46. Zeiger R, Heller S. The development and prediction of atopy in high-risk children: follow-up at age seven years in a prospective randomized study of combined maternal and infant food allergen avoidance. *J Allergy Clin Immunol* 1995;96:1179-90.
  47. Sniijders BE, Thijs C, van Ree R, van den Brandt PA. Age at first introduction of cow milk products and other food products in relation to infant atopic manifestations in the first 2 years of life: the KOALA Birth Cohort Study. *Pediatrics* 2008;122:e115-22.
  48. Katz Y, Rajuan N, Goldberg MR, Eisenberg E, Heyman E, Cohen A, et al. Early exposure to cow's milk protein is protective against IgE-mediated cow's milk protein allergy. *J Allergy Clin Immunol* 2010;126:77-82. e1.
  49. Poole JA, Barriga K, Leung DYM, Hoffman DR, Eisenbarth G, Rewers M, et al. Timing of initial exposure to cereal grains and the risk of wheat allergy. *Pediatrics* 2006;117:2175-82.
  50. Nwaru BI, Erkkola M, Ahonen S, Kaila M, Haapala AM, Kronberg-Kippila C, et al. Age at the introduction of solid foods during the first year and allergic sensitization at age 5 years. *Pediatrics* 2010;125:50-9.
  51. Kucukosmanoglu E, Yazı D, Yesil O, Akkoc T, Gezer M, Bakirci N, et al. Prevalence of egg sensitization in Turkish infants based on skin prick test. *Allergol Immunopathol (Madr)* 2008;36:141-4.
  52. Du Toit G, Katz Y, Sasieni P, Mesher D, Maleki SJ, Fisher HR, et al. Early consumption of peanuts in infancy is associated with a low prevalence of peanut allergy. *J Allergy Clin Immunol* 2008;122:984-91.
  53. Simopoulos AP. Essential fatty acids in health and chronic disease. *Am J Clin Nutr* 1999;70(3 Suppl.):560S-9S.
  54. Makrides M, Simmer K, Neumann M, Gibson R. Changes in the polyunsaturated fatty acids of breast milk from mothers of full-term infants over 30 wk of lactation. *Am J Clin Nutr* 1995;61:1231-3.
  55. Dunstan J, Mori TA, Barden A, Beilin LJ, Taylor A, Holt PG, et al. Fish oil supplementation in pregnancy modifies neonatal allergen-specific immune responses and clinical outcomes in infants at high risk of atopy: a randomised controlled trial. *J Allergy Clin Immunol* 2003;112:1178-84.
  56. Barden A, Mori TA, Dunstan JA, Taylor AL, Thornton CA, Croft KD, et al. Fish oil supplementation in pregnancy lowers F2 isoprostanes in neonates at high risk of atopy. *Free Radic Res* 2004;38:233-9.
  57. Prescott SL, Barden AE, Mori TA, Dunstan JA. Maternal fish oil supplementation in pregnancy modifies neonatal leukotriene production by cord-blood-derived neutrophils. *Clin Sci (Lond)* 2007;113:409-16.
  58. Palmer DJ, Sullivan T, Gold MS, Prescott SL, Heddle R, Gibson RA, et al. Effect of n-3 long chain polyunsaturated fatty acid supplementation in pregnancy on infants' allergies in first year of life: randomised controlled trial. *BMJ* 2012;344:e184.
  59. Palmer DJ, Sullivan T, Gold MS, Prescott SL, Heddle R, Gibson RA, et al. Randomized controlled trial of fish oil supplementation in pregnancy on childhood allergies. *Allergy* 2013;68:1370-6.
  60. D'Vaz N, Meldrum SJ, Dunstan JA, Lee-Pullen TE, Metcalfe J, Holt BJ, et al. Fish oil supplementation in early infancy modulates developing infant immune responses. *Clin Exp Allergy* 2012;42:1206-16.
  61. D'Vaz N, Meldrum SJ, Dunstan JA, Martino D, McCarthy S, Metcalfe J, et al. Postnatal fish oil supplementation in high-risk infants to prevent allergy: randomized controlled trial. *Pediatrics* 2012;130:674-82.
  62. Jenmalm MC, Duchon K. Timing of allergy-preventive and immunomodulatory dietary interventions - are prenatal, perinatal or postnatal strategies optimal? *Clin Exp Allergy* 2013;43:273-8.
  63. Mihrshahi S, Peat JK, Marks GB, Mellis CM, Tovey ER, Webb K, et al. Eighteen-month outcomes of house dust mite avoidance and dietary fatty acid modification in the Childhood Asthma Prevention Study (CAPS). *J Allergy Clin Immunol* 2003;111:162-8.
  64. Innis SM. Metabolic programming of long-term outcomes due to fatty acid nutrition in early life. *Matern Child Nutr* 2011;7(Suppl. 2):112-23.
  65. Skilton MR, Ayer JG, Harmer JA, Webb K, Leeder SR, Marks GB, et al. Impaired fetal growth and arterial wall thickening: a randomized trial of omega-3 supplementation. *Pediatrics* 2012;129:e698-703.
  66. Forsyth JS, Willatts P, Agostoni C, Bissenden J, Caser P, Boehm G. Long chain polyunsaturated fatty acid supplementation in infant formula and blood pressure in later childhood: follow up of a randomised controlled trial. *BMJ* 2003;326:953-8.
  67. Dunstan JA, Breckler L, Hale J, Lehmann H, Franklin P, Lyons G, et al. Associations between antioxidant status, markers of oxidative stress and immune responses in allergic adults. *Clin Exp Allergy* 2006;36:993-1000.
  68. Meldrum SJ, D'Vaz N, Simmer K, Dunstan JA, Hird K, Prescott SL. Effects of high-dose fish oil supplementation during early infancy on neurodevelopment and language: a randomised controlled trial. *Br J Nutr* 2012;112:64-71.
  69. Vuillermin PJ, Ponsonby AL, Kemp AS, Allen KJ. Potential links between the emerging risk factors for food allergy and vitamin D status. *Clin Exp Allergy* 2013;43:599-607.
  70. Mullins RJ, Camargo CA. Latitude, sunlight, vitamin D, and childhood food allergy/anaphylaxis. *Curr Allergy Asthma Rep* 2012;12:64-71.
  71. Mullins RJ, Clark S, Camargo CA Jr. Regional variation in epinephrine autoinjector prescriptions in Australia: more evidence for the vitamin D-anaphylaxis hypothesis. *Ann Allergy Asthma Immunol* 2009;103:488-95.
  72. Vassallo MF, Banerji A, Rudders SA, Clark S, Mullins RJ, Camargo CA Jr. Season of birth and food allergy in children. *Ann Allergy Asthma Immunol* 2010;104:307-13.
  73. Osborne NJ, Ukoumunne OC, Wake M, Allen KJ. Prevalence of eczema and food allergy is associated with latitude in Australia. *J Allergy Clin Immunol* 2012;129:865-7.
  74. Holick MF. Vitamin D deficiency. *N Engl J Med* 2007;357:266-81.
  75. Morley R, Carlin JB, Pasco JA, Wark JD, Ponsonby AL. Maternal 25-hydroxyvitamin D concentration and offspring birth size: effect modification by infant VDR genotype. *Eur J Clin Nutr* 2009;63:802-4.
  76. Allen KJ, Koplin JJ, Ponsonby AL, Gurrin LC, Wake M, Vuillermin PJ, et al. Vitamin D insufficiency is associated with challenge-proven food allergy in infants. *J Allergy Clin Immunol* 2013;131:1109-16. 16 e1-6.
  77. Cantorna MT, Mahon BD. D-hormone and the immune system. *J Rheumatol Suppl* 2005;76:11-20.
  78. Shreffler WG, Wanich N, Moloney M, Nowak-Wegrzyn A, Sampson HA. Association of allergen-specific regulatory T cells with the onset of clinical tolerance to milk protein. *J Allergy Clin Immunol* 2009;123:43-52. e7.
  79. Liu PT, Stenger S, Li H, Wenzel L, Tan BH, Krutzik SR, et al. Toll-like receptor triggering of a vitamin D-mediated human antimicrobial response. *Science* 2006;311:1770-3.
  80. Yim S, Dhawan P, Raganath C, Christakos S, Diamond G. Induction of cathelicidin in normal and CF bronchial epithelial cells by 1,25-dihydroxyvitamin D(3). *J Cyst Fibros* 2007;6:403-10.
  81. Wang TT, Dabbas B, Laperriere D, Bitton AJ, Soualhine H, Tavera-Mendoza LE, et al. Direct and indirect induction by 1,25-dihydroxyvitamin D3 of the NOD2/CARD15-defensin beta2 innate immune pathway defective in Crohn disease. *J Biol Chem* 2010;285:2227-31.
  82. Renz H, Brandtzaeg P, Hornef M. The impact of perinatal immune development on mucosal homeostasis and chronic inflammation. *Nat Rev Immunol* 2012;12:9-23.
  83. Pfefferle PI, Prescott SL, Kopp M. Microbial influence on tolerance and opportunities for intervention with prebiotics/probiotics and bacterial lysates. *J Allergy Clin Immunol* 2013;131:1453-63. quiz 64.
  84. Maslowski KM, Mackay CR. Diet, gut microbiota and immune responses. *Nat Immunol* 2011;12:5-9.
  85. Blumer N, Sel S, Virna S, Patrascan CC, Zimmermann S, Herz U, et al. Perinatal maternal application of *Lactobacillus rhamnosus* GG suppresses allergic airway inflammation in mouse offspring. *Clin Exp Allergy* 2007;37:348-57.
  86. Abrahamsson TR, Jakobsson HE, Andersson AF, Bjorksten B, Engstrand L, Jenmalm MC. Low diversity of the gut microbiota in infants with atopic eczema. *J Allergy Clin Immunol* 2012;129:434-40. 40 e1-2.
  87. Schaub B, Liu J, Hoppler S, Schleich I, Huehn J, Olek S, et al. Maternal farm exposure modulates neonatal immune mechanisms through regulatory T cells. *J Allergy Clin Immunol* 2009;123:774-82. e5.
  88. Prescott S, Macaubas C, Smallacombe T, Holt B, Sly P, Loh R, et al. Development of allergen-specific T-cell memory in atopic and normal children. *Lancet* 1999;353:196-200.
  89. Smith M, Tourigny MR, Noakes P, Thornton CA, Tulic MK, Prescott SL. Children with egg allergy have evidence of reduced neonatal CD4(+)CD25(+)CD127(lo/-) regulatory T cell function. *J Allergy Clin Immunol* 2008;121:1460-6. 6 e1-7.
  90. Tulic MK, Andrews D, Crook ML, Charles A, Tourigny MR, Moqbel R, et al. Changes in thymic regulatory T-cell maturation from birth to puberty: differences in atopic children. *J Allergy Clin Immunol* 2012;129:199-206. e1-4.
  91. Ege MJ, Bieli C, Frei R, van Strien RT, Riedler J, Ublagger E, et al. Prenatal farm exposure is related to the expression of receptors of

- the innate immunity and to atopic sensitization in school-age children. *J Allergy Clin Immunol* 2006;117:817–23.
92. Rautava S, Luoto R, Salminen S, Isolauri E. Microbial contact during pregnancy, intestinal colonization and human disease. *Nat Rev Gastroenterol Hepatol* 2012;9:565–76.
  93. Rautava S, Collado MC, Salminen S, Isolauri E. Probiotics modulate host-microbe interaction in the placenta and fetal gut: a randomized, double-blind, placebo-controlled trial. *Neonatology* 2012;102:178–84.
  94. Jenmalm MC, Duchén K. Timing of allergy-preventive and immunomodulatory dietary interventions – are prenatal, perinatal or postnatal strategies optimal? *Clin Exp Allergy* 2013;43:273–8.
  95. Kalliomäki M, Salminen S, Arvilommi H, Kero P, Koskinen P, Isolauri E. Probiotics in primary prevention of atopic disease: a randomised placebo-controlled trial. *Lancet* 2001;357:1076–9.
  96. Rautava S, Kainonen E, Salminen S, Isolauri E. Maternal probiotic supplementation during pregnancy and breast-feeding reduces the risk of eczema in the infant. *J Allergy Clin Immunol* 2012;130:1355–60.
  97. Pelucchi C, Chatenoud L, Turati F, Galeone C, Moja L, Bach JF, et al. Probiotics supplementation during pregnancy or infancy for the prevention of atopic dermatitis: a meta-analysis. *Epidemiology* 2012;23:402–14.
  98. Tang ML, Lahtinen SJ, Boyle RJ. Probiotics and prebiotics: clinical effects in allergic disease. *Curr Opin Pediatr* 2010;22:626–34.
  99. Osborn D, Sinn J. Probiotics in infants for prevention of allergic disease and food hypersensitivity. *Cochrane Database Syst Rev* 2007;4:CD006475.
  100. Lee J, Seto D, Bielory L. Meta-analysis of clinical trials of probiotics for prevention and treatment of pediatric atopic dermatitis. *J Allergy Clin Immunol* 2008;121:116–21. e11.
  101. Doege K, Grajecki D, Zyriax BC, Detinkina E, Zu Eulenburg C, Buhling KJ. Impact of maternal supplementation with probiotics during pregnancy on atopic eczema in childhood – a meta-analysis. *Br J Nutr* 2012;107:1–6.
  102. Koren O, Goodrich JK, Cullender TC, Spor A, Laitinen K, Backhed HK, et al. Host remodeling of the gut microbiome and metabolic changes during pregnancy. *Cell* 2012;150:470–80.
  103. Bertelsen RJ, Brantsaeter AL, Magnus MC, Haugen M, Myhre R, Jacobsson B, et al. Probiotic milk consumption in pregnancy and infancy and subsequent childhood allergic diseases. *J Allergy Clin Immunol* 2014;133:165–71. e8.
  104. Aaltonen J, Ojala T, Laitinen K, Poussa T, Ozanne S, Isolauri E. Impact of maternal diet during pregnancy and breastfeeding on infant metabolic programming: a prospective randomized controlled study. *Eur J Clin Nutr* 2011;65:10–19.
  105. Prescott SL, Wickens K, Westcott L, Jung W, Currie H, Black PN, et al. Supplementation with *Lactobacillus rhamnosus* or *Bifidobacterium lactis* probiotics in pregnancy increases cord blood interferon-gamma and breast milk transforming growth factor-beta and immunoglobulin A detection. *Clin Exp Allergy* 2008;38:1606–14.
  106. Moro G, Arslanoglu S, Stahl B, Jelinek J, Wahn U, Boehm G. A mixture of prebiotic oligosaccharides reduces the incidence of atopic dermatitis during the first six months of age. *Arch Dis Child* 2006;91:814–19.
  107. Maslowski KM, Vieira AT, Ng A, Kranich J, Sierro F, Yu D, et al. Regulation of inflammatory responses by gut microbiota and chemottractant receptor GPR43. *Nature* 2009;461:1282–6.
  108. Vulevic J, Juric A, Tzortzis G, Gibson GR. A mixture of trans-galactooligosaccharides reduces markers of metabolic syndrome and modulates the fecal microbiota and immune function of overweight adults. *J Nutr* 2013;143:324–31.
  109. Gruber C, van Stuijvenberg M, Mosca F, Moro G, Chirico G, Braegger CP, et al. Reduced occurrence of early atopic dermatitis because of immunoactive prebiotics among low-atopy-risk infants. *J Allergy Clin Immunol* 2010;126:791–7.
  110. Arslanoglu S, Moro GE, Schmitt J, Tandoi L, Rizzardi S, Boehm G. Early dietary intervention with a mixture of prebiotic oligosaccharides reduces the incidence of allergic manifestations and infections during the first two years of life. *J Nutr* 2008;138:1091–5.
  111. Maurer AD, Reimer RA. Maternal consumption of high-prebiotic fibre or -protein diets during pregnancy and lactation differentially influences satiety hormones and expression of genes involved in glucose and lipid metabolism in offspring in rats. *Br J Nutr* 2011;105:329–38.
  112. Fujiwara R, Takemura N, Watanabe J, Sonoyama K. Maternal consumption of fructooligosaccharide diminishes the severity of skin inflammation in offspring of NC/Nga mice. *Br J Nutr* 2010;103:530–8.
  113. Shadid R, Haarman M, Knol J, Theis W, Beermann C, Rjosk-Dendorfer D, et al. Effects of galactooligosaccharide and long-chain fructooligosaccharide supplementation during pregnancy on maternal and neonatal microbiota and immunity – a randomized, double-blind, placebo-controlled study. *Am J Clin Nutr* 2007;86:1426–37.
  114. Kukkonen K, Savilahti E, Haahtela T, Juntenen-Backman K, Korpela R, Poussa T, et al. Probiotics and prebiotic galacto-oligosaccharides in the prevention of allergic diseases: a randomized, double-blind, placebo-controlled trial. *J Allergy Clin Immunol* 2007;119:192–8.
  115. Hansen LG, Halcken S, Host A, Møller K, Østerballe O. Prediction of allergy from family history and cord blood IgE levels. *Pediatr Allergy Immunol* 1993;4:34–40.
  116. Hide DW, Arshad SH, Twiselton R, Stevens M. Cord serum IgE: an insensitive method for prediction of atopy. *Clin Exp Allergy* 1991;21:739–43.
  117. Bergmann RL, Edenharter G, Bergmann KE, Guggenmoos-Holzmann I, Forster J, Bauer CP, et al. Predictability of early atopy by cord blood IgE and parental history. *Clin Exp Allergy* 1997;27:752–60.
  118. Allam JP, Zivanovic O, Berg C, Gembruch U, Bieber T, Novak N. In search for predictive factors for atopy in human cord blood. *Allergy* 2005;60:743–50.
  119. Leung R, Carlin J, Burdon J, Czarny D. Asthma, allergy and atopy in Asian immigrants in Melbourne. *Med J Aust* 1994;161:418–25.
  120. Sicherer SH, Wood RA, Stablein D, Lindblad R, Burks AW, Liu AH, et al. Maternal consumption of peanut during pregnancy is associated with peanut sensitization in atopic infants. *J Allergy Clin Immunol* 2010;126:1191–7.
  121. Dharmage SC, Martin PE, Osborne NJ, Koplin JJ, Gurrin LC, Ponsonby AL, et al. The epidemiology of food sensitization-associated eczema in infancy in HealthNuts, a population-based study. *J Allergy Clin Immunol* 2011;127:AB35. 02/01.
  122. Martin PE, Koplin JJ, Eckert JK, Lowe AJ, Ponsonby AL, Osborne NJ, et al. The prevalence and socio-demographic risk factors of clinical eczema in infancy: a population-based observational study. *Clin Exp Allergy* 2013;43:642–51.
  123. Branum AM, Lukacs SL. Food allergy among U.S. children: trends in prevalence and hospitalizations. *NCHS Data Brief* 2008;10:1–8.
  124. Martin PE, Eckert JK, Koplin JJ, Lowe AJ, Gurrin LC, Dharmage SC, et al. Which infants with eczema are at risk of food allergy? Results from a population-based cohort. *Clin Exp Allergy* 2015;45:255–64.
  125. Brown SJ, Asai Y, Cordell HJ, Campbell LE, Zhao Y, Liao H, et al. Loss-of-function variants in the filaggrin gene are a significant risk factor for peanut allergy. *J Allergy Clin Immunol* 2011;127:661–7.
  126. Lack G. Update on risk factors for food allergy. *J Allergy Clin Immunol* 2012;129:1187–97.
  127. Wood RA. The natural history of food allergy. *Pediatrics* 2003;111(6 Pt 3):1631–7.
  128. Sicherer SH, Munoz-Furlong A, Sampson HA. Prevalence of peanut and tree nut allergy in the United States determined by means of a random digit dial telephone survey: a 5-year follow-up study. *J Allergy Clin Immunol* 2003;112:1203–7.
  129. Sampson HA. Update on food allergy. *J Allergy Clin Immunol* 2004;113:805–19. quiz 20.
  130. Host A, Halcken S. A prospective study of cow milk allergy in Danish infants during the first 3 years of life. Clinical course in relation to clinical and immunological type of hypersensitivity reaction. *Allergy* 1990;45:587–96.
  131. Tariq SM, Stevens M, Matthews S, Ridout S, Twiselton R, Hide DW. Cohort study of peanut and tree nut sensitisation by age of 4 years. *BMJ* 1996;313:514–17.
  132. Kulig M, Bergmann R, Klettke U, Wahn U, Tacke U, Wahn U. Natural course of sensitization to food and inhalant allergens during the first 6 years of life. *J Allergy Clin Immunol* 1999;103:1173–9.
  133. Skripak JM, Matsui EC, Mudd K, Wood RA. The natural history of IgE-mediated cow's milk allergy. *J Allergy Clin Immunol* 2007;120:1172–7.
  134. Savage JH, Matsui EC, Skripak JM, Wood RA. The natural history of egg allergy. *J Allergy Clin Immunol* 2007;120:1413–17.
  135. Peters RL, Dharmage SC, Gurrin LC, Koplin JJ, Ponsonby AL, Lowe AJ, et al. The natural history and clinical predictors of egg allergy in the first 2 years of life: a prospective, population-based cohort study. *J Allergy Clin Immunol* 2014;133:485–91.
  136. Sicherer SH, Wood RA, Vickery BP, Jones SM, Liu AH, Fleischer DM, et al. The natural history of egg allergy in an observational cohort. *J Allergy Clin Immunol* 2014;133:492–9.
  137. Ho MH, Wong WH, Heine RG, Hosking CS, Hill DJ, Allen KJ. Early clinical predictors of remission of peanut allergy in children. *J Allergy Clin Immunol* 2008;121:731–6.

138. Busse PJ, Nowak-Wegrzyn AH, Noone SA, Sampson HA, Sicherer SH. Recurrent peanut allergy. *N Engl J Med* 2002;347:1535–6.
139. De Frutos C, Zapatero L, Rodriguez A, Baranco R, Alonso E, Martinez MI. Re-sensitization to fish after a temporary tolerance. *Allergy* 2003;58:1067–8.
140. Fleischer DM, Conover-Walker MK, Christie L, Burks AW, Wood RA. The natural progression of peanut allergy: resolution and the possibility of recurrence. *J Allergy Clin Immunol* 2003;112:183–9.
141. Fleischer DM, Conover-Walker MK, Matsui EC, Wood RA. The natural history of tree nut allergy. *J Allergy Clin Immunol* 2005;116:1087–93.
142. Vila L, Beyer K, Jarvinen KM, Chatchatee P, Bardina L, Sampson HA. Role of conformational and linear epitopes in the achievement of tolerance in cow's milk allergy. *Clin Exp Allergy* 2001;31:1599–606.
143. Lemon-Mulé H, Sampson HA, Sicherer SH, Shreffler WG, Noone S, Nowak-Wegrzyn A. Immunologic changes in children with egg allergy ingesting extensively heated egg. *J Allergy Clin Immunol* 2008;122:977–83. e1.
144. Nowak-Wegrzyn A, Bloom KA, Sicherer SH, Shreffler WG, Noone S, Wanich N, et al. Tolerance to extensively heated milk in children with cow's milk allergy. *J Allergy Clin Immunol* 2008;122:342–7. 7 e1-2.
145. Kim JS, Nowak-Wegrzyn A, Sicherer SH, Noone S, Moshier EL, Sampson HA. Dietary baked milk accelerates the resolution of cow's milk allergy in children. *J Allergy Clin Immunol* 2011;128:125–31. e2.
146. Leonard SA, Sampson HA, Sicherer SH, Noone S, Moshier EL, Godbold J, et al. Dietary baked egg accelerates resolution of egg allergy in children. *J Allergy Clin Immunol* 2012;130:473–80. e1.

# Enterocolitis, Proctocolitis and Enteropathies

SCOTT H. SICHERER | ANNA NOWAK-WĘGRZYN

## KEY POINTS

- A number of gastrointestinal food allergic disorders are not typically associated with food-specific IgE antibodies.
- These dietary protein-induced cell-mediated disorders usually present in infancy.
- There is a broad differential diagnosis to consider when evaluating infants with possible gastrointestinal food allergy.
- Diagnosis may require medically supervised oral food challenges, and treatment requires dietary elimination.
- Except for celiac disease, these non-IgE-mediated gastrointestinal allergies typically resolve during childhood.

This chapter focusses upon four non-IgE-mediated food hypersensitivity disorders that affect the gastrointestinal tract: food protein-induced proctocolitis, enterocolitis, enteropathy and celiac disease.<sup>1</sup> These disorders have overlapping symptoms, but are distinguishable clinically and have distinct patterns of symptoms and clinical course.<sup>2</sup>

## Epidemiology/Etiology

### DIETARY PROTEIN PROCTOCOLITIS

*Eosinophilic proctocolitis* is characterized by the presence of mucus, bloody stools in an otherwise healthy infant. The disorder is attributed to an immune response directed, most commonly, against cow's milk protein. The mean age at diagnosis is approximately 60 days, with a range of 1 day to 6 months.<sup>3-6</sup> The bleeding is often mistakenly attributed to perirectal fissures, although bleeding associated with fissures tends to present with streaks of blood on hard, formed stool rather than mixed in frothy, mucousy stool, which is typical of proctocolitis. Failure to thrive is absent. About 60% of cases occur in breastfed infants where the immune response results from maternal ingestion of the food allergen, usually cow's milk, which is passed in immunologically recognizable form into the breast milk. In formula-fed infants, the reaction is associated with cow's milk or, less commonly, soy.<sup>4,7</sup> Proctocolitis has rarely been described in infants fed hypoallergenic, extensively hydrolyzed formulas.<sup>8</sup> Associated peripheral blood eosinophilia, hypoalbuminemia and/or anemia are uncommon.<sup>4,9,10</sup> Markers of atopy such as

atopic dermatitis or a positive family history of atopy are not significantly increased compared with the general population.

Endoscopic examination is usually not needed for diagnostic purposes but, when performed, shows patchy erythema, friability and a loss of vascularity generally limited to the rectum.<sup>11</sup> High numbers of eosinophils (5 to 20 per high-power field) or eosinophilic abscesses are seen in the lamina propria, crypt epithelium and muscularis mucosa.<sup>9,12</sup> The eosinophils are frequently associated with lymphoid nodules (lymphonodular hyperplasia)<sup>9,13</sup> and rarely with granuloma formation.<sup>14</sup> However, lymphonodular hyperplasia is not unique to this condition.<sup>9,12</sup> The pathophysiology is unknown. Because inflammation is confined to the lower colon and is common in breastfed infants, it has been hypothesized that dietary antigens complexed to breast milk IgA may play a part in the activation of eosinophils and the distribution of the inflammatory process.<sup>3</sup>

The frequency of food allergy causing rectal bleeding in infants has not been extensively studied. Xanthakos and colleagues<sup>5</sup> performed colonoscopy and biopsy on 22 infants presenting with rectal bleeding, and proved eosinophilic colitis in 14 (64%). The remainder had normal biopsies (23%) or non-specific colitis (14%). This group recommended dietary elimination for those with eosinophilic colitis and the majority had resolution within 1 to 3 weeks. However, the relationship of cow's milk protein to symptoms was not proven by rechallenge. Arvola and colleagues<sup>15</sup> examined 40 infants presenting with rectal bleeding. Infants were randomized to either avoid cow's milk protein or maintain their current diet. The duration or severity of bleeding was no different between the two groups. During follow-up, cow's milk allergy was diagnosed in 18% of the infants (based upon various criteria including flares of atopic dermatitis and urticaria upon food challenge as well as rectal bleeding) and for these infants, there was a reduced length of bleeding when they had been randomized to an elimination diet at study outset. Atopic dermatitis and inflammation of the colonic mucosa were associated with persistence of cow's milk allergy to the age of 1 year. These studies indicate that food allergy may not be a common cause of rectal bleeding in infants unless there are additional signs of allergy, and that milk protein-induced proctocolitis has to be differentiated from benign idiopathic neonatal transient eosinophilic colitis.<sup>6,16</sup>

### FOOD PROTEIN-INDUCED ENTEROCOLITIS SYNDROME (DIETARY PROTEIN ENTEROCOLITIS) (Box 44-1)

*Food protein-induced enterocolitis syndrome* [FPIES]) describes a symptom constellation of profuse vomiting, lethargy and diarrhea, usually diagnosed in the first months of life and most commonly attributable to an immune response to cow's milk or soy.<sup>17</sup>



**BOX 44-1 CLINICAL PEARLS: FOOD PROTEIN-INDUCED ENTEROCOLITIS SYNDROME (FPIES)**

- May mimic sepsis with presentations that include vomiting, lethargy, diarrhea, acidemia, leukocytosis, thrombocytosis, hypotension and methemoglobinemia.
- Common triggers include milk, soy, rice and oats.
- For infants with milk or soy FPIES, use an extensively hydrolyzed casein-based formula rather than a soy or milk formula due to common (up to 50%) concomitant FPIES to these foods.
- For infants with milk/soy FPIES, avoid oats/rice as first solids.
- Onset of FPIES after the age of 1 year is uncommon and FPIES typically resolves in the first 1 to 5 years.
- Children with detectable milk-specific IgE antibodies have a more protracted course than those without IgE antibodies; some may convert to immediate IgE-mediated milk allergy.

Inflammation involves both the small and large bowels. Unlike allergic proctocolitis, the majority of affected infants are asymptomatic while exclusively breastfed on an unrestricted maternal diet. When the causal protein remains in the diet (e.g. in young infants fed with cow's milk or soy-based formulas), chronic symptoms can include watery or bloody diarrhea, poor growth, anemia, hypoalbuminemia and fecal leukocytes; the illness may progress to dehydration and hypotension over the course of days to weeks.<sup>18–20</sup> Removal of the causal protein leads to resolution of symptoms but re-exposure results in a characteristic delayed (by about 1 to 3 hours) onset of repetitive, often projectile vomiting, lethargy, elevation of the peripheral blood polymorphonuclear leukocyte count and possibly reduced temperature, thrombocytosis, hypotension, diarrhea, dehydration, acidemia and methemoglobinemia.<sup>21</sup> These reactions mimic sepsis.

Powell<sup>22</sup> initially characterized the syndrome. She described nine infants with severe, protracted diarrhea and vomiting. The symptoms developed at 4 to 27 days after birth (mean, 11 days) in infants on a cow's milk-based formula. Switching to a soy-based formula resulted in transient improvement, but symptoms generally recurred in 7 days. Seven of the nine infants were below birth weight, and eight of nine presented with dehydration. Eight of the infants appeared acutely ill and underwent sepsis evaluations that were negative. All infants were noted to have low serum albumin, elevated peripheral blood polymorphonuclear leukocyte counts, and stools that were positive for hemoglobin and reducing substances. The hospital course usually involved improvement while on intravenous fluids, followed by recurrence of dramatic symptoms with reintroduction of soy- or cow's milk-based formula, including the development of shock in several infants. Follow-up with oral challenges was carried out with cow's milk and soybean formulas at a mean age of 5.5 months, and 14 of the 18 challenges were positive. Ten of 14 challenges resulted in vomiting (onset 1 to 2.5 hours after ingestion; mean 2.1 hours) and all experienced diarrhea (onset 2 to 10 hours; mean 5 hours) with blood, polymorphonuclear leukocytes and eosinophils, and increased carbohydrate in the stool. There was a rise in peripheral blood polymorphonuclear cell counts in all positive challenges, peaking at 6 hours after ingestion, with a mean rise of 9900 cells/mm<sup>3</sup> (range 5,500 to 16,800 cells/mm<sup>3</sup>). Only isolated gastrointestinal symptoms were reported.

The results of these studies led Powell<sup>22,23</sup> to propose criteria for a positive oral challenge to diagnose food protein-

induced enterocolitis of infancy.<sup>24</sup> Confirmation of the allergy included a negative search for other causes, improvement when not ingesting the causal protein and a positive oral challenge resulting in vomiting/diarrhea, evidence of gastrointestinal inflammation through stool examination, and a rise in the peripheral polymorphonuclear leukocyte count to over 3,500 cells/mL.

Numerous foods, other than milk and soy, have subsequently been documented as triggers for FPIES, including rice, oat, meats, fish, fruits, vegetables and egg.<sup>25–29</sup> The dramatic nature of the presentation often results in evaluations for sepsis or surgical diagnoses,<sup>30</sup> and a delay in final diagnosis until more than one episode has occurred.<sup>25</sup>

Since infantile FPIES is a diagnosis that can be made clinically, there are no large series in which biopsies have been performed solely in patients fulfilling Powell's criteria. Regarding immunopathology, studies have focussed upon the role of T cells and the importance of tumor necrosis factor (TNF)- $\alpha$ .<sup>31–35</sup> In a large cohort of Japanese infants with non-IgE-mediated food allergy, TNF- $\alpha$ , interleukin (IL)-6, and Th2 cytokines (IL-3, IL-5 and IL-13), but not interferon (IFN)- $\gamma$  or IL-17 were increased in the supernatant from milk protein-stimulated peripheral blood mononuclear cell cultures of patients compared to nonallergic controls.<sup>36</sup> Chung and colleagues<sup>37</sup> examined the presence of TNF- $\alpha$  in duodenal biopsy specimens using immunostains in infants with FPIES. Semiquantitative analyses revealed higher staining for TNF- $\alpha$  in affected infants with villus atrophy compared to those without atrophy and in normal controls. Taken together, these studies support the notion that TNF- $\alpha$  plays a role in the acute and chronic symptoms of FPIES. It is also known that the regulatory cytokine transforming growth factor (TGF)- $\beta$ 1 is involved in the protection of the epithelial barrier of the gut from the penetration of foreign antigens.<sup>37–39</sup> Chung and colleagues<sup>37</sup> demonstrated that the type 1, but not type 2, receptor for TGF- $\beta$ 1 were decreased in duodenal biopsy specimens in patients with FPIES compared to controls. Analysis of humoral features in milk-induced enterocolitis showed milk-protein specific IgA, but very low levels of specific IgG1 and IgG4; this has been theorized to be pathogenic because IgG4 might otherwise block complement fixing antibodies.<sup>40</sup> Specific IgE is sometimes noted as well, and may be a marker of persistence.<sup>21,41,42</sup>

## DIETARY PROTEIN ENTEROPATHY

This disorder is characterized by protracted diarrhea, vomiting, malabsorption and failure to thrive. Additional features may include abdominal distention, early satiety, edema, hypoproteinemia and protein-losing enteropathy.<sup>43</sup> Symptoms usually begin in the first several months of life, depending on the time of exposure to the causal proteins. The disorder was described primarily from the 1960s to the 1990s<sup>44–47</sup> and was commonly attributed to cow's milk protein. A decrease in prevalence was documented in Finland<sup>48</sup> and Spain<sup>49</sup> and attributed to a rise in breastfeeding and/or the use of adapted infant formula. There have been no clear reports of this diagnosis in the past several years, although presentations of eosinophilic gastroenteritis with protein-losing enteropathy share many features with previous descriptions of this disorder.<sup>50–52</sup>

Unlike gluten-sensitive enteropathy (celiac disease), this enteropathy generally resolves in 1 to 2 years, and there is no increased threat of future malignancy.<sup>53</sup>

## CELIAC DISEASE

Celiac disease, also termed *celiac sprue* or *gluten-sensitive enteropathy* and estimated to affect 1% of the population, is caused by an immune response triggered by wheat gluten or related rye and barley proteins that results in inflammatory injury to the small intestinal mucosa.<sup>54-57</sup> The classic presentation occurs in infants after weaning, at the time when cereals are introduced into the diet. Early (<4 months of age) or delayed (>7 months) introduction of wheat may be a risk factor,<sup>58,59</sup> and breastfeeding may be a related protective factor.<sup>60</sup> Symptoms partly reflect malabsorption, with patients exhibiting failure to thrive, anemia and muscle wasting. Additional symptoms are varied and include diarrhea, abdominal pain, vomiting, osteoporosis, bone pain and aphthous stomatitis. Subclinical or minimal disease is possible, delaying diagnosis into adulthood.<sup>57</sup> Chronic ingestion of gluten-containing grains in patients with celiac disease is associated with increased risk of enteropathy-associated T cell lymphoma. Celiac disease is associated with autoimmune disorders and IgA deficiency. Another associated disorder is *dermatitis herpetiformis*,<sup>61</sup> a gluten-responsive dermatitis characterized by pruritic, erythematous papules, and/or vesicles distributed symmetrically on the extensor surfaces of the elbows and knees, and also on the face, buttocks, neck and trunk.

Endoscopy of the small bowel in active celiac disease typically reveals total villous atrophy and extensive cellular infiltrate. The disorder is caused by gliadin-specific T cell responses against deamidated gliadin produced by tissue transglutaminase.<sup>62</sup> Gliadin stimulation of monocytes and macrophages may also contribute to the inflammatory response.<sup>63,64</sup> Antigen presentation appears to be a central issue in the immunopathology because about 95% of patients are HLA-DQ2, with the remainder being HLA-DQ8.<sup>54,65</sup> Gliadin is one of the few substrates for tissue transglutaminase, which deamidates specific glutamines within gliadin, creating epitopes that bind efficiently to DQ2 gut-derived T cells.<sup>66</sup> The activation of DQ2- or DQ8-restricted T cells initiates the inflammatory response.<sup>56</sup> Elimination of gliadin from the diet results in a down-regulation of the T cell-induced inflammatory process and normalization of the mucosal histology.

## Differential Diagnosis

Because the gastrointestinal tract has a limited number of responses to inflammatory damage, there is an overlap in the symptoms observed with these disorders. Differentiating them requires consideration of key, distinct clinical features and directed laboratory examinations. Moreover, numerous medical disorders must be considered in the evaluation of patients presenting with gastrointestinal complaints. Some of these disorders include other food hypersensitivities, but food intolerance (nonimmune disorders such as lactase deficiency) and toxic reactions (e.g. bacterial poisoning) are potential considerations.

The differential diagnosis can encompass virtually any cause of abdominal complaint, including the following categories: infection (viral, bacterial, parasitic), anatomic (pyloric stenosis, anal fissures, motility disorders, lymphangiectasia, Hirschsprung's disease, reflux, intussusception), inflammatory disorders (inflammatory bowel disease), metabolic disorders (disaccharidase deficiencies), malignancy, immunodeficiency and others. The differential diagnosis of severe FPIES includes

anaphylaxis. Depending on the constellation of findings, various diagnostic strategies are used, description of which is beyond the scope of this chapter. However, the presence of a number of clinical elements may underscore the possibility of a food allergic disorder. The general approach to the diagnosis of food-allergic disorders affecting the gut is outlined in [Figure 44-1](#). Various features may suggest a differentiation of the disorders described in this chapter from those related to IgE antibody-mediated gastrointestinal allergies (oral allergy, gastrointestinal anaphylaxis) and those that are sometimes associated with IgE antibodies (eosinophilic gastroenteropathies and reflux). The timing of symptoms following ingestion of the causal food (acute in IgE antibody-mediated disease), symptoms (isolated vomiting in gastroesophageal reflux disease) and selected test results (biopsy revealing an eosinophilic infiltrate in allergic eosinophilic gastroenteropathy) differentiate these food allergic disorders. The food-related disorders must also be distinguished from a host of disorders that have similar clinical findings but alternative etiologies. [Table 44-1](#) delineates the disorders whose features may most closely overlap the cell-mediated food allergic disorders.

The distinguishing clinical features of dietary protein-induced proctocolitis, enteropathy, enterocolitis and celiac disease are listed in [Table 44-2](#). Although they may represent a spectrum of disorders with similar etiologies, the treatment and natural course of these diseases vary, making a specific diagnosis imperative. The causal foods, symptoms and family history usually indicate the likely disorder. In some cases, the diagnosis requires initial confirmation of reactivity/association determined by resolution of symptoms with an elimination diet and recurrence of symptoms after oral challenge.<sup>1,2</sup> In some cases, specific tests are needed (e.g. serologic tests for IgA endomysial or tissue transglutaminase antibody and small bowel biopsy). The disorders are not IgE antibody-mediated, but if there has been immediate onset of symptoms following ingestion or an association of gastrointestinal allergy with other features of IgE antibody-mediated food allergy (e.g. atopic dermatitis, asthma), screening tests for food-specific IgE antibody (prick skin tests, serum food-specific IgE antibodies) may be helpful in defining the process causing the reactions. A number of tests are of unproved value for the diagnosis of food allergy and should not be used. These include measurement of IgG4 antibody, provocation-neutralization (drops placed under the tongue or injected to diagnose and treat various symptoms) and applied kinesiology (muscle strength testing).<sup>67</sup>

## Evaluation and Management

### DIETARY PROTEIN PROCTOCOLITIS

The diagnosis of dietary protein proctocolitis should be entertained in an infant who is otherwise well and presents with mucousy bloody stools, an absence of symptoms indicating a systemic disease, coagulation defect or another source of bleeding. The definitive diagnosis requires withdrawal of the presumed allergen with monitoring for resolution of symptoms; however, additional testing and refeeding of the eliminated protein is advisable after resolution because transient rectal bleeding in infancy is more frequently not related to allergy.<sup>15</sup> A survey of 56 pediatric gastroenterologists showed that 84% prescribe empiric dietary trials.<sup>5</sup> In the absence of biopsy confirmation and especially in the absence of other signs of atopy,

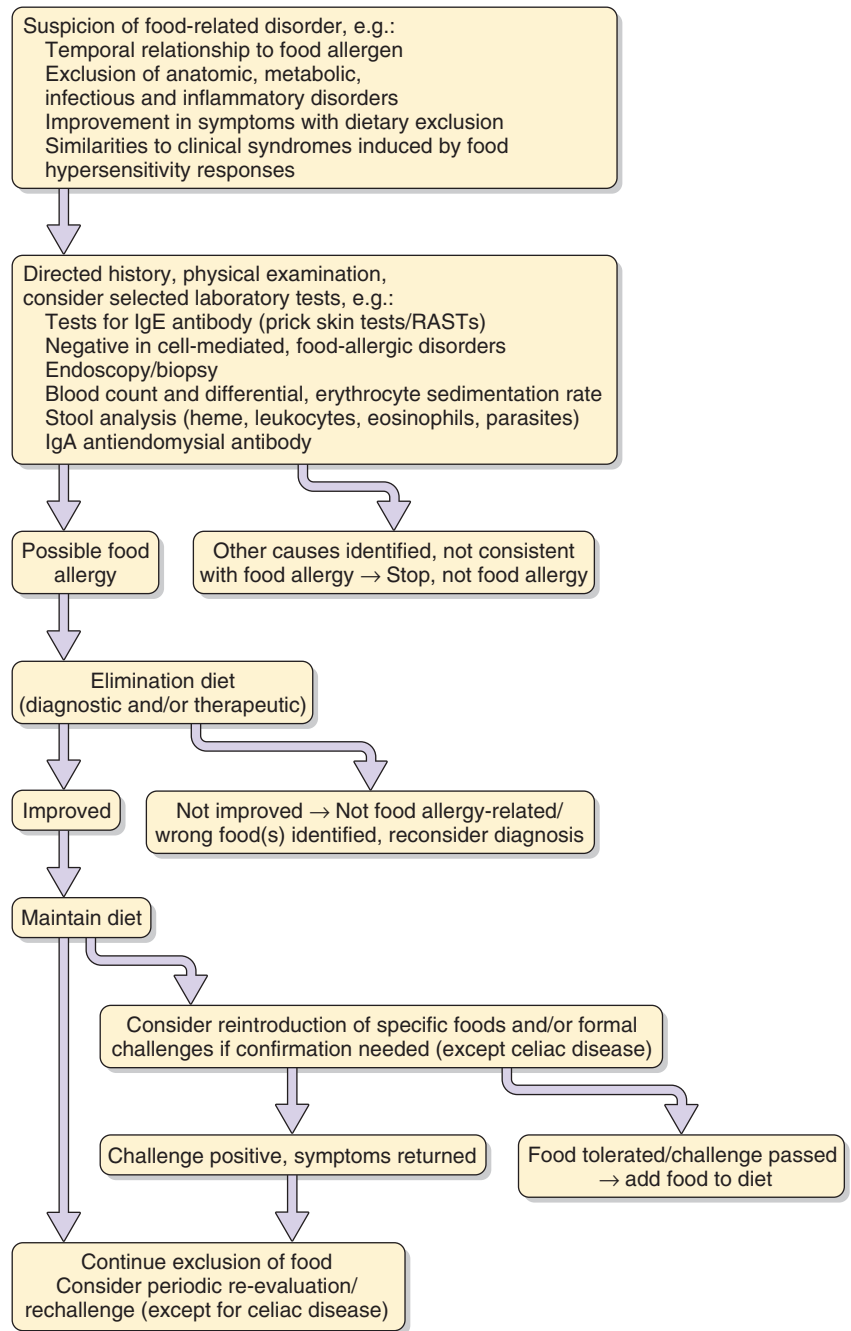

**Figure 44-1** Evaluation of food allergy requires a simultaneous consideration of alternative diagnoses (infection, anatomic, metabolic, etc.) and disorders caused by food allergy, including those described in this chapter and others (i.e. oral allergy syndrome, anaphylaxis, eosinophilic gastroenteropathies, food-related reflux disease) and nonimmune adverse reactions to foods (lactose intolerance). Laboratory tests and decisions for elimination and challenge are based on specific elements of the history and an appreciation for the clinical manifestations and course of the various disorders (see text). RAST – Radioallergosorbent test.

refeeding should be considered soon after resolution of symptoms, given the high rate of spontaneous resolution.<sup>6,16</sup> In cow's milk or soy formula-fed infants, substitution with a protein hydrolysate formula can be undertaken. The majority of infants who develop this condition while ingesting protein hydrolysate formulas will experience resolution of bleeding with the substitution of an amino acid-based formula, although follow-up challenges to prove that the formula substitution was required have not been systematically undertaken.<sup>5,8,68</sup> Management in breastfed infants requires maternal restriction of cow's milk or possibly soy, egg or other foods.<sup>4</sup> In up to 12% of breastfed infants, bleeding may persist despite extensive food elimination from the maternal diet and requires switching the infant to a

hypoallergenic formula. If breastfeeding is continued, chronic bleeding may lead to mild anemia despite iron supplementation and to hypoalbuminemia. In spite of the persistent symptoms, most children become tolerant to cow's milk by the age of 12 months and have no long-term sequelae.<sup>3</sup> Progressive bleeding, despite dietary restriction, should prompt re-evaluation with consideration for proctocolonoscopy and biopsy.<sup>69</sup> Since there is generally no risk of a severe reaction, the foods can be gradually reintroduced into the diet either as a trial to prove a causal relationship or months afterward to monitor for resolution of the allergy. However, if there is a suspicion of mild enterocolitis (e.g. vomiting in addition to hematochezia) or a history to suggest IgE-mediated reactions, dietary advancement may

require caution with repeated testing (e.g. skin or serum tests for specific IgE to the causal food) and medically supervised oral food challenges (OFCs).

### FOOD PROTEIN-INDUCED ENTEROCOLITIS SYNDROME

As noted earlier, the diagnosis of FPIES rests on clinical and challenge criteria. Most patients do not undergo a formal challenge during infancy because the diagnosis becomes self-evident after elimination of the causal protein, and frequently patients experience inadvertent re-exposure, proving their sensitivity before a diagnostic test feeding.<sup>67</sup> It must be appreciated that chronic ingestion, or re-exposure to the causal food, can result in a clinical picture that is severe, may mimic sepsis, and may include acidemia and methemoglobinemia.<sup>21,25,27,41,42,70–72</sup> Approximately half of infants with cow's milk reactions also react to soy, and among children reacting to milk/soy, about 25% react to additional proteins such as rice or oat.<sup>41,42,71</sup> Since

there is a high percentage of patients with sensitivity to both cow's milk and soy, switching directly to a casein hydrolysate is recommended. For the rare patients reactive to hydrolysate, an amino acid-based formula is appropriate.<sup>42,73</sup> Caution and delay are also advised regarding the introduction of common triggers such as rice and oat when milk/soy reactions have already occurred.<sup>17,74</sup>

Follow-up challenges should be performed at intervals to determine tolerance (approximately every 12 to 24 months, depending on the clinical severity). These challenges should be performed under physician supervision with intravenous fluids and emergency medications immediately available because dramatic reactions, including shock, can occur. Re-evaluation for the development of antigen-specific IgE antibody before challenge is helpful because 4–30% of cases develop IgE antibodies to the FPIES food, and among those with food-specific IgE, one in four converts to IgE-mediated reactions over time.<sup>21,41,42</sup> Patch testing does not provide diagnostic information.<sup>75,76</sup> In the experience of the authors,<sup>21,42</sup> about half of positive challenges require treatment (usually intravenous fluids). In view of the presumed T cell involvement in FPIES pathophysiology, corticosteroids have been administered for severe reactions. A small case series suggested effectiveness of intravenous ondansetron for stopping emesis induced during FPIES OFCs.<sup>77</sup> Five children older than 3 years who developed emesis during an FPIES OFC were treated with a 0.2 mg/kg dose of ondansetron, together with an intravenous physiologic saline bolus. Three of the four children treated with intravenous ondansetron experienced resolution of emesis and lethargy within 10 to 15 minutes, while one required an additional dose of ondansetron. Another child who was treated with oral ondansetron required an additional dose of intravenous ondansetron to improve severe abdominal pain. Intramuscular ondansetron has been used in five young children (four were under the age of 3 years) with rapid resolution of symptoms during the OFC.<sup>78</sup> Ondansetron is usually well tolerated, although special caution may be warranted in children with underlying heart disease due to the potential to prolong the QT interval. More studies are needed to define the role of ondansetron in FPIES management.

While intravenous fluids constitute first-line management in the treatment of FPIES, the role of epinephrine in treatment is not known, but it should be available in case of severe cardiovascular reactions. Given the risk for hypotension, the challenge is best performed under physician supervision with consideration for obtaining intravenous access. Food challenges for this non-IgE-mediated syndrome are typically performed with 0.06 to 0.6 g/kg of the causal protein, with lower doses for those patients with a history of severe reactions. The challenge protocol and definition of a positive response are shown in [Table 44-3](#).

TABLE 44-1

**Examples of Clinical Disease That May Overlap Symptoms of Cell-Mediated, Dietary Protein-Induced Disease**

Clinical Disease	Symptoms
Proctocolitis	Anal fissure Infection Perianal dermatitis Transient idiopathic neonatal eosinophilic colitis Necrotizing enterocolitis Volvulus Hirschsprung's disease Intussusception Coagulation disorders
FPIES	Sepsis/infection Necrotizing enterocolitis Intussusception Lymphangiectasia Volvulus Ileus Metabolic disorder
Enteropathy	Infection Eosinophilic gastroenteropathy with protein loss Bowel ischemia Inflammatory bowel disease Lymphangiectasia Autoimmune enteropathy Immune deficiency Tropical sprue Malignancy

TABLE 44-2

**Clinical Features Helpful in Distinguishing Dietary Protein-Induced Proctocolitis, Enteropathy, Enterocolitis and Celiac Disease**

	Vomiting	Diarrhea	Growth	Foods	Other	Onset
Proctocolitis	Absent	Minimal, bloody	Normal	Breast/milk/soy		Days to 6 months
FPIES	Prominent	Prominent	Poor	Milk/soy/rice/oat	Re-exposure: severe, subacute symptoms	Days to 1 year; adult onset to shellfish
Enteropathy	Variable	Moderate	Poor	Milk/soy	Edema due to intestinal protein loss	2–24 months
Celiac	Variable	Variable	Poor	Gluten	HLA-DQ2-associated	>4 months



**TABLE 44-3** Oral Food Challenges for Food Protein-Induced Enterocolitis Syndrome

Diagnostic Step	Procedures and Assessment
Preparation for challenge	Verify normal weight gain, no gastrointestinal symptoms while off causal protein Obtain baseline stool sample and peripheral blood polymorphonuclear leukocyte count Consider intravenous access Medications ready to treat reaction
Administration of challenge	Administer challenge (typically 0.15–0.6 g of food protein/kg body weight) Observe for symptoms (usual onset of vomiting 1–3 hours) Repeat peripheral blood polymorphonuclear leukocyte count 6 hours after ingestion Collect subsequent stools for 24 hours
Evaluation of positive challenge	Symptoms (vomiting, lethargy, diarrhea) Rise in peripheral polymorphonuclear leukocyte count (>3,500 cells/mm <sup>3</sup> ) Fecal blood (gross or occult) Fecal leukocytes Fecal eosinophils Positive challenge: three of five criteria positive Equivocal: two of five criteria positive

From Powell<sup>24</sup> and Sicherer et al.<sup>21</sup>

The natural history is variable, depending on the population studied. A large population-based cohort study from Israel reported resolution of milk FPIES in 90% by age 2 years.<sup>79</sup> A retrospective study of 35 children from Australia evaluated over a span of 16 years showed rice (14 children), soy<sup>12</sup> and milk<sup>7</sup> to be the most common triggers, and sensitivity was lost by the age of 3 years to rice and soy in about 80%.<sup>25</sup> In a cohort of 23 Korean infants with milk/soy FPIES, resolution rates were 64% for milk and 92% for soy by 10 months of age and all were tolerant by 20 months.<sup>80</sup> In a retrospective US study, overall significantly lower rates of resolution of FPIES were found, 35% by age 2 years, 70% by age 3 years and 85% by age 5 years.<sup>41</sup> In a mixed design US study, overall median age at resolution of milk FPIES was 13 years, while the median age for patients with undetectable milk IgE antibodies was 5 years, indicating that IgE positivity is associated with a more persistent form of FPIES.<sup>42</sup> These differences may reflect differences in study designs and/or selection bias toward a more severe and persistent phenotype among children evaluated at referral centers. About 50% of children outgrow rice or oat FPIES by age 4 to 5 years.<sup>41,42,81</sup> However, some patients maintain their allergy well beyond the age of 6 years, even into adulthood.<sup>41,42,81</sup>

### DIETARY PROTEIN ENTEROPATHY AND CELIAC DISEASE

There are no specific diagnostic tests for dietary protein-induced enteropathy; therefore, the diagnosis depends on exclusion of alternative diagnoses, biopsy evidence of enteropathy, and proof of sensitivity through dietary elimination and rechallenge. Since the symptoms are not as dramatic as enterocolitis syndrome, observation during dietary ingestion and exclusion of the causal protein must be undertaken to verify the diagnosis. Unlike dietary protein enteropathy, celiac disease can be evaluated in part through specific *in vitro* tests. Tests for IgA antiendomysial

antibody (using tissue transglutaminase) are sensitive (85–98%) and specific (94–100%) with excellent positive (91–100%) and negative (80–98%) predictive values.<sup>56,82,83</sup> If celiac disease is suspected based on a suspicious cadre of findings (family history, steatorrhea, anemia, failure to thrive), serologic tests for IgA endomysial antibody and a small bowel biopsy should be undertaken.<sup>55,56,84,85</sup> If there is enteropathy, but negative serology, alternative diagnoses (see Tables 44-1 and 44-2) should be reconsidered. If the diagnosis is not strongly suspected, the *in vitro* tests can be undertaken, and if negative, the diagnosis is generally excluded, but a positive test would warrant confirmation with a biopsy. A gluten-free diet is necessary to treat celiac disease and must be maintained indefinitely. However, enteropathy induced by milk generally resolves in 1 to 2 years, at which time rechallenge is warranted.

### Treatment

There are no curative therapies for dietary protein-induced proctocolitis, enteropathy, enterocolitis or celiac disease; treatment is based on dietary elimination. Only patients with dietary protein-induced enterocolitis or some individuals with celiac disease and ‘celiac crisis’ experience severe reactions, so these patients must also be instructed on how to proceed in the event of an accidental ingestion. Such patients should report to an emergency department in the event that fluid resuscitation is needed.

Education concerning dietary management is reviewed elsewhere (Chapter 48). It must be emphasized that education about the details of avoidance is crucial so that dietary elimination trials and therapeutic interventions are accurately undertaken. Often, recurrence of symptoms is caused by poor adherence or insufficient education. Issues of cross-contamination, label reading, restaurant dining and even the use of medications that may contain causal food proteins make avoidance of major dietary proteins very difficult. With celiac disease, oat does not contain gluten,<sup>56,86</sup> but contamination of oat flour with wheat gluten remains a problem. Support groups and the advice of a knowledgeable dietician are crucial adjuncts for patients undertaking these nutritionally and socially limiting diets.

Even without performing adjunctive laboratory tests or challenges to confirm a specific disorder, switching between milk, soy and casein-hydrolysate formulas is commonly undertaken by pediatricians and families as a test of intolerance or allergy. There are no specific guidelines concerning these formula changes. It is helpful to know that only a small proportion of infants with IgE-mediated cow’s milk allergy (14%) will react to soy.<sup>87</sup> In contrast, those with FPIES are more likely (40–50%) to react to soy protein. For these infants, a switch to extensively hydrolyzed cow’s milk-based formula should be considered. For the few infants with symptoms that persist while taking a casein hydrolysate, amino acid-based formula may be required.<sup>42,88</sup> Breastfeeding is preferred over commercial formulas as the source for infant nutrition, but maternally ingested protein can elicit allergic symptoms in the breastfed infant.<sup>19,89,90</sup> Therefore, maternal dietary manipulation (e.g. avoidance of milk protein) can be undertaken for treatment of breastfed infants, but with infants who have multiple food allergies this may be difficult, so substitution with infant formulas may be needed in some cases.

Except for celiac disease, resolution of the allergy is expected, so a review of the diet and any accidental exposures, and tests

as indicated are undertaken on a yearly basis with the expectation that proctocolitis will resolve in 1 year and protein-induced enteropathy and enterocolitis in general in 1 to 3 years. It has been hypothesized that some adults with isolated gastrointestinal responses to foods (usually seafood) may have a stable form of mild enterocolitis.<sup>91</sup>

## Conclusions

Dietary protein-induced proctocolitis, enterocolitis (FPIES) and enteropathy (including celiac disease) represent well-characterized immunologic responses to dietary proteins (Box 44-2). Although distinct in their clinical presentation, they represent cell-mediated hypersensitivity disorders that are not based on IgE antibody-mediated mechanisms. The symptoms of these disorders generally present in infancy or early childhood and must be differentiated from disorders with similar symptoms, and from each other. A careful clinical history, limited laboratory studies, and directed elimination and challenge can readily disclose the type of disorder and causal foods. Knowledge of the course of these disorders assists in making a plan for long-term therapy: either reintroduction of the food to determine if tolerance has occurred or prolonged dietary elimination. The immunologic mechanisms of these disorders are being elucidated, and these advances are likely to permit improved diagnostic and therapeutic strategies in the future.

 The complete reference list can be found on the companion Expert Consult website at <http://www.expertconsult.inkling.com>.

### BOX 44-2 KEY CONCEPTS: EVALUATION AND MANAGEMENT OF DIETARY PROTEIN-INDUCED, CELL-MEDIATED DISORDERS

- The differential diagnosis of cell-mediated (non-IgE-mediated) gastrointestinal food allergic disorders includes other types of food hypersensitivity (IgE-mediated, eosinophilic gastroenteropathy), nonimmune reactions to foods, and disorders with similar manifestations (infection, anatomic disorders, metabolic disease).
- Diagnosis requires a history, physical examination, exclusion of alternative diagnoses and selected diagnostic procedures, including dietary elimination and oral challenge, biopsy and selected laboratory evaluations.
- Proctocolitis occurs in infants and consists of mucousy, bloody stools attributed primarily to cow's milk proteins passed in maternal breast milk. However, rectal bleeding in infants is not commonly caused by food allergy.
- Enteropathy occurs in infancy and has symptoms related to protein malabsorption. It is most commonly caused by cow's milk protein and generally resolves by age 1 to 3 years.
- FPIES occurs in infancy and has symptoms that include prominent vomiting, lethargy, diarrhea and growth failure with possible progression to a sepsis-like clinical picture. It is usually attributed to cow's milk and/or soy protein and usually resolves by the age of 1 to 5 years.
- Celiac disease often presents at weaning due to an immunologic response to gluten. The disease may present at any age. Classic symptoms include vomiting, anemia, poor growth, and steatorrhea. The diagnosis is assisted through serology for IgA antiendomysial antibodies and is a lifelong disorder requiring elimination of gluten.

## KEY REFERENCES

- Lake AM, Whittington PF, Hamilton SR. Dietary protein-induced colitis in breast-fed infants. *J Pediatr* 1982;101:906–10.
- Mori M, Ohtsuka Y, Ishida A, Yamazaki S, Jimbo K, Inage E, et al. Outcome of infants presenting rectal bleeding: a retrospective study in a single institution. *Pediatr Int* 2014;56:884–90.
- Jarvinen K, Nowak-Węgrzyn A. Food protein-induced enterocolitis syndrome: current management strategies. *J Allergy Clin Immunol Pract* 2013;1:317.
- Nomura I, Morita H, Hosokawa S, Hoshina H, Fukuie T, Watanabe M, et al. Four distinct subtypes of non-IgE-mediated gastrointestinal food allergies in neonates and infants, distinguished by their initial symptoms. *J Allergy Clin Immunol* 2011;127:685–8. e1–8.
- Ruffner MA, Ruymann K, Barni S, Cianferoni A, Brown Whitehorn T, Spergel JM. Food protein-induced enterocolitis syndrome: insights from review of a large referral population. *J Allergy Clin Immunol Pract* 2013;1:343–9.
- Caubet JMFL, Sickles L, Järvinen KM, Sicherer SH, Sampson HA, Nowak-Węgrzyn A. Clinical features and resolution of food protein-induced enterocolitis syndrome: 10-year experience. *J Allergy Clin Immunol* 2014;134:382–9.
- Green PH, Cellier C. Celiac disease. *N Engl J Med* 2007;357:1731–43.
- Fasano A, Catassi C. Clinical practice. Celiac disease. *N Engl J Med* 2012;367:2419–26.
- Katz Y, Goldberg MR, Rajuan N, Cohen A, Leshno M. The prevalence and natural course of food protein-induced enterocolitis syndrome to cow's milk: a large-scale, prospective population-based study. *J Allergy Clin Immunol* 2011;127:647–53. e1–3.
- Husby S, Koletzko S, Korponay-Szabo IR, Mearin ML, Phillips A, Shamir R, et al. European Society for Pediatric Gastroenterology, Hepatology, and Nutrition guidelines for the diagnosis of coeliac disease. *J Pediatr Gastroenterol Nutr* 2012;54:136–60.

## REFERENCES

- Sicherer SH, Sampson HA. Food allergy: epidemiology, pathogenesis, diagnosis, and treatment. *J Allergy Clin Immunol* 2014;133:291–307; quiz 308.
- Caubet JC, Nowak-Węgrzyn A. Current understanding of the immune mechanisms of food protein-induced enterocolitis syndrome. *Expert Rev Clin Immunol* 2011;7:317–27.
- Lake AM. Food-induced eosinophilic proctocolitis. *J Pediatr Gastroenterol Nutr* 2000;30(Suppl 1):S58–60.
- Lake AM, Whittington PF, Hamilton SR. Dietary protein-induced colitis in breast-fed infants. *J Pediatr* 1982;101:906–10.
- Xanthakos SA, Schwimmer JB, Melin-Aldana H, Rothenberg ME, Witte DP, Cohen MB. Prevalence and outcome of allergic colitis in healthy infants with rectal bleeding: a prospective cohort study. *J Pediatr Gastroenterol Nutr* 2005;41:16–22.
- Mori M, Ohtsuka Y, Ishida A, Yamazaki S, Jimbo K, Inage E, et al. Outcome of infants presenting rectal bleeding: a retrospective study in a single institution. *Pediatr Int* 2014;56:884–90.
- Anveden-Hertzberg L, Finkel Y, Sandstedt B, Karpe B. Proctocolitis in exclusively breast-fed infants. *Eur J Pediatr* 1996;155:464–7.
- Vanderhoof JA, Murray ND, Kaufman SS, Mack DR, Antonson DL, Corkins MR, et al. Intolerance to protein hydrolysate infant formulas: an underrecognized cause of gastrointestinal symptoms in infants. *J Pediatr* 1997;131:741–4.
- Odze RD, Bines J, Leichtner AM, Goldman H, Antonioli DA. Allergic proctocolitis in infants: a prospective clinicopathologic biopsy study. *Hum Pathol* 1993;24:668–74.
- Wilson NW, Self TW, Hamburger RN. Severe cow's milk induced colitis in an exclusively breast-fed neonate. Case report and clinical review of cow's milk allergy. *Clin Pediatr* 1990;29:77–80.
- Jenkins HR, Pincott JR, Soothill JF, Milla PJ, Harries JT. Food allergy: the major cause of infantile colitis. *Arch Dis Child* 1984;59:326–9.
- Winter HS, Antonioli DA, Fukagawa N, Marcial M, Goldman H. Allergy-related proctocolitis in infants: diagnostic usefulness of rectal biopsy. *Mod Pathol* 1990;3:5–10.
- Ravelli A, Villanacci V, Chiappa S, Bolognini S, Manenti S, Fuoti M. Dietary protein-induced proctocolitis in childhood. *Am J Gastroenterol* 2008;103:2605–12.
- Dargent JL, Souayah H, Hainaut M. Granulomatous variant of allergic proctocolitis. *Histopathology* 2009;55:758–60.
- Arvola T, Ruuska T, Keranen J, Hyoty H, Salminen S, Isolauri E. Rectal bleeding in infancy: clinical, allergological, and microbiological examination. *Pediatrics* 2006;117:e760–8.
- Jang HJ, Kim AS, Hwang JB. The etiology of small and fresh rectal bleeding in not-sick neonates: should we initially suspect food protein-induced proctocolitis? *Eur J Pediatr* 2012;171:1845–9.
- Jarvinen K, Nowak-Węgrzyn A. Food protein-induced enterocolitis syndrome: current management strategies. *J Allergy Clin Immunol Pract* 2013;1:317.
- Hwang JB, Lee SH, Kang YN, Kim SP, Suh SI, Kam S. Indexes of suspicion of typical cow's milk protein-induced enterocolitis. *J Korean Med Sci* 2007;22:993–7.
- Nomura I, Morita H, Hosokawa S, Hoshina H, Fukuie T, Watanabe M, et al. Four distinct subtypes of non-IgE-mediated gastrointestinal food allergies in neonates and infants, distinguished by their initial symptoms. *J Allergy Clin Immunol* 2011;127:685–8. e1–8.
- Feuille E, Nowak-Węgrzyn A. Definition, etiology, and diagnosis of food protein-induced enterocolitis syndrome. *Curr Opin Allergy Clin Immunol* 2014;14:222–8.
- Sicherer SH, Eigenmann PA, Sampson HA. Clinical features of food protein-induced enterocolitis syndrome. *J Pediatr* 1998;133:214–19.
- Powell GK. Milk- and soy-induced enterocolitis of infancy. Clinical features and standardization of challenge. *J Pediatr* 1978;93:553–60.
- Powell GK. Enterocolitis in low-birth-weight infants associated with milk and soy protein intolerance. *J Pediatr* 1976;88:840–4.
- Powell GK. Food protein-induced enterocolitis of infancy: differential diagnosis and management. *Compr Ther* 1986;12:28–37.
- Mehr S, Kakakios A, Frith K, Kemp AS. Food protein-induced enterocolitis syndrome: 16-year experience. *Pediatrics* 2009;123:e459–64.
- Mehr SS, Kakakios AM, Kemp AS. Rice: a common and severe cause of food protein-induced enterocolitis syndrome. *Arch Dis Child* 2009;94:220–3.
- Nowak-Węgrzyn A, Sampson HA, Wood RA, Sicherer SH. Food protein-induced enterocolitis syndrome caused by solid food proteins. *Pediatrics* 2003;111(4 Pt 1):829–35.
- Zapatero Remon L, Alonso Lebrero E, Martin Fernandez E, Martinez Molero MI. Food-protein-induced enterocolitis syndrome caused by fish. *Allergol Immunopathol* 2005;33:12–16.
- Vandenplas Y, Edelman R, Sacre L. Chicken-induced anaphylactoid reaction and colitis. *J Pediatr Gastroenterol Nutr* 1994;19:240–1.
- Jayasooriya S, Fox AT, Murch SH. Do not laparotomize food-protein-induced enterocolitis syndrome. *Pediatr Emerg Care* 2007;23:173–5.
- Heyman M, Darmon N, Dupont C, Dugas B, Hirribaren A, Blaton MA, et al. Mononuclear cells from infants allergic to cow's milk secrete tumor necrosis factor alpha, altering intestinal function. *Gastroenterology* 1994;106:1514–23.
- Kapel N, Matarazzo P, Haouchine D, Abiola N, Guerin S, Magne D, et al. Fecal tumor necrosis factor alpha, eosinophil cationic protein and IgE levels in infants with cow's milk allergy and gastrointestinal manifestations. *Clin Chem Lab Med* 1999;37:29–32.
- Majamaa H, Aittoniemi J, Miettinen A. Increased concentration of fecal alpha1-antitrypsin is associated with cow's milk allergy in infants with atopic eczema. *Clin Exp Allergy* 2001;31:590–2.
- Benlounes N, Dupont C, Candalh C, Blaton MA, Darmon N, Desjeux JF, et al. The threshold for immune cell reactivity to milk antigens decreases in cow's milk allergy with intestinal symptoms. *J Allergy Clin Immunol* 1996;98:781–9.
- Benlounes N, Candalh C, Matarazzo P, Dupont C, Heyman M. The time-course of milk antigen-induced TNF-alpha secretion differs according to the clinical symptoms in children with cow's milk allergy. *J Allergy Clin Immunol* 1999;104(4 Pt 1):863–9.
- Morita H, Nomura I, Matsuda A, Saito H, Matsumoto K. Gastrointestinal food allergy in infants. *Allergol Int* 2013;62:297–307.
- Chung HL, Hwang JB, Park JJ, Kim SG. Expression of transforming growth factor beta1, transforming growth factor type I and II receptors, and TNF-alpha in the mucosa of the small intestine in infants with food protein-induced enterocolitis syndrome. *J Allergy Clin Immunol* 2002;109:150–4.
- Planchon S, Fiocchi C, Takafuji V, Roche JK. Transforming growth factor-beta1 preserves epithelial barrier function: identification of receptors, biochemical intermediates, and cytokine antagonists. *J Cell Physiol* 1999;181:55–66.
- Planchon SM, Martins CA, Guerrant RL, Roche JK. Regulation of intestinal epithelial barrier function by TGF-beta 1. Evidence for its role in abrogating the effect of a T cell cytokine. *J Immunol* 1994;153:5730–9.
- Shek LP, Bardina L, Castro R, Sampson HA, Beyer K. Humoral and cellular responses to cow milk proteins in patients with milk-induced IgE-mediated and non-IgE-mediated disorders. *Allergy* 2005;60:912–19.
- Ruffner MA, Ruyman K, Barni S, Cianferoni A, Brown Whitehorn T, Spergel JM. Food protein-induced enterocolitis syndrome: insights from review of a large referral population. *J Allergy Clin Immunol Pract* 2013;1:343–9.
- Caubet JMFL, Sickles L, Jarvinen KM, Sicherer SH, Sampson HA, Nowak-Węgrzyn A. Clinical features and resolution of food protein-induced enterocolitis syndrome: 10-year experience. *J Allergy Clin Immunol* 2014;134:382–9.
- Sampson HA, Anderson JA. Summary and recommendations: Classification of gastrointestinal manifestations due to immunologic reactions to foods in infants and young children. *J Pediatr Gastroenterol Nutr* 2000;30(Suppl.):S87–94.
- Kuitunen P, Visakorpi JK, Savilahti E, Pelkonen P. Malabsorption syndrome with cow's milk intolerance. Clinical findings and course in 54 cases. *Arch Dis Child* 1975;50:351–6.
- Iyngkaran N, Yadav M, Boey CG, Lam KL. Severity and extent of upper small bowel mucosal damage in cow's milk protein-sensitive enteropathy. *J Pediatr Gastroenterol Nutr* 1988;7:667–74.
- Yssing M, Jensen H, Jarnum S. Dietary treatment of protein-losing enteropathy. *Acta Paediatr Scand* 1967;56:173–81.
- Walker-Smith JA. Food sensitive enteropathies. *Clin Gastroenterol* 1986;15:55–69.
- Verkasalo M, Kuitunen P, Savilahti E, Tiilikainen A. Changing pattern of cow's milk intolerance. An analysis of the occurrence and clinical course in the 60s and mid-70s. *Acta Paediatr Scand* 1981;70:289–95.
- Vitoria JC, Sojo A, Rodriguez-Soriano J. Changing pattern of cow's milk protein intolerance. *Acta Paediatr Scand* 1990;79:566–7.
- Chehade M, Magid MS, Mofidi S, Nowak-Węgrzyn A, Sampson HA, Sicherer SH. Allergic eosinophilic gastroenteritis with protein-losing enteropathy: intestinal pathology, clinical course, and long-term follow-up. *J Pediatr Gastroenterol Nutr* 2006;42:516–21.
- Ko J, Magid MS, Benkov KJ, Chehade M, Nowak-Węgrzyn A. A 17-month-old boy with periorbital swelling. *Ann Allergy Asthma Immunol* 2004;93:220–6.
- Kondo M, Fukao T, Omoya K, Kawamoto N, Aoki M, Teramoto T, et al. Protein-losing enteropathy associated with egg allergy in a

- 5-month-old boy. *J Investig Allergol Clin Immunol* 2008;18:63–6.
53. Walker-Smith JA. Cow milk-sensitive enteropathy: predisposing factors and treatment. *J Pediatr* 1992;121(5 Pt 2):S111–15.
  54. Sollid LM, Lie BA. Celiac disease genetics: current concepts and practical applications. *Clin Gastroenterol Hepatol* 2005;3:843–51.
  55. Farrell RJ, Kelly CP. Celiac sprue. *N Engl J Med* 2002;346:180–8.
  56. Green PH, Cellier C. Celiac disease. *N Engl J Med* 2007;357:1731–43.
  57. Fasano A, Catassi C. Clinical practice. Celiac disease. *N Engl J Med* 2012;367:2419–26.
  58. Norris JM, Barriga K, Hoffenberg EJ, Taki I, Miao D, Haas JE, et al. Risk of celiac disease autoimmunity and timing of gluten introduction in the diet of infants at increased risk of disease. *JAMA* 2005;293:2343–51.
  59. Sellitto M, Bai G, Serena G, Fricke WF, Sturgeon C, Gajer P, et al. Proof of concept of microbiome-metabolome analysis and delayed gluten exposure on celiac disease autoimmunity in genetically at-risk infants. *PLoS ONE* 2012;7:e33387.
  60. Ivarsson A, Hernell O, Stenlund H, Persson LA. Breast-feeding protects against celiac disease. *Am J Clin Nutr* 2002;75:914–21.
  61. Egan CA, O'Loughlin S, Gormally S, Powell FC. Dermatitis Herpetiformis: a review of fifty-four patients. *Ir J Med Sci* 1997;166:241–4.
  62. Molberg O, McAdam S, Lundin KE, Kristiansen C, Arentz-Hansen H, Kett K, et al. T cells from celiac disease lesions recognize gliadin epitopes deamidated in situ by endogenous tissue transglutaminase. *Eur J Immunol* 2001;31:1317–23.
  63. Harris KM, Fasano A, Mann DL. Cutting edge: IL-1 controls the IL-23 response induced by gliadin, the etiologic agent in celiac disease. *J Immunol* 2008;181:4457–60.
  64. Thomas KE, Sapone A, Fasano A, Vogel SN. Gliadin stimulation of murine macrophage inflammatory gene expression and intestinal permeability are MyD88-dependent: role of the innate immune response in Celiac disease. *J Immunol* 2006;176:2512–21.
  65. Johnson TC, Diamond B, Memeo L, Negulescu H, Hovhanissyan Z, Verkarre V, et al. Relationship of HLA-DQ8 and severity of celiac disease: comparison of New York and Parisian cohorts. *Clin Gastroenterol Hepatol* 2004;2:888–94.
  66. Anderson RP, Degano P, Godkin AJ, Jewell DP, Hill AV. In vivo antigen challenge in celiac disease identifies a single transglutaminase-modified peptide as the dominant A-gliadin T-cell epitope. *Nat Med* 2000;6:337–42.
  67. Boyce JA, Assa'ad A, Burks AW, Jones SM, Sampson HA, Wood RA, et al. Guidelines for the Diagnosis and Management of Food Allergy in the United States: summary of the NIAID-sponsored expert panel report. *J Allergy Clin Immunol* 2010;126:1105–18.
  68. Lucarelli S, Di Nardo G, Lastrucci G, D'Alfonso Y, Marcheggiano A, Federici T, et al. Allergic proctocolitis refractory to maternal hypoallergenic diet in exclusively breast-fed infants: a clinical observation. *BMC Gastroenterol* 2011;11:82.
  69. Sampson HA, Sicherer SH, Birnbaum AH. AGA technical review on the evaluation of food allergy in gastrointestinal disorders. *American Gastroenterological Association. Gastroenterology* 2001;120:1026–40.
  70. Murray KF, Christie DL. Dietary protein intolerance in infants with transient methemoglobinemia and diarrhea. *J Pediatr* 1993;122:90–2.
  71. Burks AW, Casteel HB, Fiedorek SC, Williams LW, Pumphrey CL. Prospective oral food challenge study of two soybean protein isolates in patients with possible milk or soy protein enterocolitis. *Pediatr Allergy Immunol* 1994;5:40–5.
  72. Sopo SM, Giorgio V, Dello Iacono I, Novembre E, Mori F, Onesimo R. A multicentre retrospective study of 66 Italian children with food protein-induced enterocolitis syndrome: different management for different phenotypes. *Clin Exp Allergy* 2012;42:1257–65.
  73. Kelso JM, Sampson HA. Food protein-induced enterocolitis to casein hydrolysate formulas. *J Allergy Clin Immunol* 1993;92:909–10.
  74. Sicherer SH. Food protein-induced enterocolitis syndrome: case presentations and management lessons. *J Allergy Clin Immunol* 2005;115:149–56.
  75. Jarvinen KM, Caubet JC, Sickles L, Ford LS, Sampson HA, Nowak-Wegrzyn A. Poor utility of atopy patch test in predicting tolerance development in food protein-induced enterocolitis syndrome. *Ann Allergy Asthma Immunol* 2012;109:221–2.
  76. Fogg MI, Brown-Whitehorn TA, Pawlowski NA, Spergel JM. Atopy patch test for the diagnosis of food protein-induced enterocolitis syndrome. *Pediatr Allergy Immunol* 2006;17:351–5.
  77. Holbrook T, Keet CA, Frischmeyer-Guerrero PA, Wood RA. Use of ondansetron for food protein-induced enterocolitis syndrome. *J Allergy Clin Immunol* 2013;132:1219–20.
  78. Miceli Sopo S, Batista A, Greco M, Monaco S. Ondansetron for food protein-induced enterocolitis syndrome. *Int Arch Allergy Immunol* 2014;164:137–9.
  79. Katz Y, Goldberg MR, Rajuan N, Cohen A, Leshno M. The prevalence and natural course of food protein-induced enterocolitis syndrome to cow's milk: a large-scale, prospective population-based study. *J Allergy Clin Immunol* 2011;127:647–53. e1–3.
  80. Hwang JB, Sohn SM, Kim AS. Prospective follow-up oral food challenge in food protein-induced enterocolitis syndrome. *Arch Dis Child* 2009;94:425–8.
  81. Katz Y, Goldberg MR. Natural history of food protein-induced enterocolitis syndrome. *Curr Opin Allergy Clin Immunol* 2014;14:229–39.
  82. Rostom A, Dube C, Cranney A, Saloojee N, Sy R, Garrity C, et al. The diagnostic accuracy of serologic tests for celiac disease: a systematic review. *Gastroenterology* 2005;128(4 Suppl. 1):S38–46.
  83. Wolf J, Hasenclever D, Petroff D, Richter T, Uhlig HH, Laabeta MW, et al. Antibodies in the diagnosis of coeliac disease: a biopsy-controlled, international, multicentre study of 376 children with coeliac disease and 695 controls. *PLoS ONE* 2014;9:e97853.
  84. Husby S, Koletzko S, Korponay-Szabo IR, Mearin ML, Phillips A, Shamir R, et al. European Society for Pediatric Gastroenterology, Hepatology, and Nutrition guidelines for the diagnosis of coeliac disease. *J Pediatr Gastroenterol Nutr* 2012;54:136–60.
  85. Rubio-Tapia A, Hill ID, Kelly CP, Calderwood AH, Murray JA. ACG clinical guidelines: diagnosis and management of celiac disease. *Am J Gastroenterol* 2013;108:656–76. quiz 77.
  86. Hoffenberg EJ, Haas J, Drescher A, Barnhurst R, Osberg I, Bao F, et al. A trial of oats in children with newly diagnosed celiac disease. *J Pediatr* 2000;137:361–6.
  87. Zeiger RS, Sampson HA, Bock SA, Burks AW Jr, Harden K, Noone S, et al. Soy allergy in infants and children with IgE-associated cow's milk allergy. *J Pediatr* 1999;134:614–22.
  88. Isolauri E, Sutas Y, Makinen-Kiljunen S, Oja SS, Isosomppi R, Turjanmaa K. Efficacy and safety of hydrolyzed cow milk and amino acid-derived formulas in infants with cow milk allergy. *J Pediatr* 1995;127:550–7.
  89. Nomura I, Morita H, Ohya Y, Saito H, Matsumoto K. Non-IgE-mediated gastrointestinal food allergies: distinct differences in clinical phenotype between Western countries and Japan. *Curr Allergy Asthma Rep* 2012;12:297–303.
  90. Jarvinen KM, Makinen-Kiljunen S, Suomalainen H. Cow's milk challenge through human milk evokes immune responses in infants with cow's milk allergy. *J Pediatr* 1999;135:506–12.
  91. Fernandes BN, Boyle RJ, Gore C, Simpson A, Custovic A. Food protein-induced enterocolitis syndrome can occur in adults. *J Allergy Clin Immunol* 2012;130:1199–200.



# Allergic and Eosinophilic Gastrointestinal Disease

AMANDA B. MUIR | JONATHAN E. MARKOWITZ | CHRIS A. LIACOURAS

## KEY POINTS

- IgE-mediated anaphylactic reactions to foods occur immediately after ingestion, are acute life-threatening events, and can cause gastrointestinal, pulmonary and cardiovascular symptoms.
- Eosinophilic esophagitis (EoE), involving chronic eosinophilic inflammation limited to the esophagus, causes weight loss, feeding difficulties, emesis, dysphagia and food impaction.
- Eosinophilic gastroenteritis (EoG) involves eosinophilic infiltration into any area of the gastrointestinal tract, most commonly the stomach and small intestine.
- Eosinophilic proctocolitis (EoP) usually presents in early infancy as a result of milk protein intolerance.

## Overview

Gastrointestinal disorders involving an accumulation of eosinophils include a variety of conditions including classic IgE-mediated food allergy, inflammatory bowel disease, gastroesophageal reflux and the primary eosinophilic gastrointestinal disorders (eosinophilic esophagitis, eosinophilic gastroenteritis and eosinophilic colitis). The goal of this chapter is to provide an overview of those conditions that are characterized by an eosinophilic infiltration in the gastrointestinal tract and are largely driven by food-specific antigens. Food hypersensitivity will be briefly reviewed; the majority of the discussion will focus on the primary eosinophilic gastrointestinal disorders.

## Food Allergy or Hypersensitivity

### IgE-MEDIATED ALLERGY AND ANAPHYLAXIS

Type I (IgE-mediated) immediate hypersensitivity reactions to foods are most common in young children, with 50% of these reactions developing in the first year of life. The majority are reactions to cow's milk or to soy protein from infant formulas.<sup>1</sup> Other food allergies begin to predominate in older children, including egg, fish, peanut and wheat. Together with milk and soy, these account for more than 90% of food allergy in children.<sup>2</sup>

Blinded food challenges have shown that symptoms referable to the gastrointestinal tract in IgE-mediated allergy typically begin within minutes of the ingestion, although occasionally they may be delayed for up to 2 hours. They tend to be short-lived, lasting 1 to 2 hours.<sup>3,4</sup> Symptoms include nausea,

vomiting, abdominal pain and diarrhea; there may also be oral symptoms, skin manifestations, wheezing or airway edema.

## Eosinophilic Gastroenteropathies

The eosinophilic gastroenteropathies are an interesting, yet somewhat poorly defined set of disorders that must include the infiltration of at least one layer of the gastrointestinal tract with eosinophils, in the absence of other known causes for eosinophilia (e.g. parasitic infections or drug reactions).<sup>5,6</sup> Peripheral eosinophilia is not required for diagnosis, although it is a frequent finding. First reported over 50 years ago, the clinical spectrum of these disorders was defined solely by various case reports. As these reports became more frequent, various aspects of the disease became better described and stratified. Additional insight into the role of the eosinophil in health and disease has allowed further description of these disorders with respect to the underlying defect that drives the inflammatory response in those afflicted. Perhaps most important to the definition of these disorders has been the understanding of the heterogeneity of the sites affected within the gastrointestinal tract (Box 45-1).

Eosinophilic gastroenteropathies are thought to arise from the interaction of genetic and environmental factors. Of note, approximately 10% of individuals with one of these disorders has a family history in an immediate family member.<sup>7</sup> In addition there is evidence for the role of allergy in the etiology of these conditions, including the observations that up to 75% of patients are atopic<sup>8,9</sup> and that an allergen-free diet can sometimes reverse disease activity.<sup>8-10</sup> Interestingly, only a minority of individuals with eosinophilic gastroenteropathies have food-induced anaphylaxis<sup>11</sup> and therefore these disorders exhibit properties that are intermediate between pure IgE-mediated allergy and cellular mediated hypersensitivity disorders.

### EOSINOPHILIC ESOPHAGITIS

Eosinophilic esophagitis (EoE) represents a chronic, immune/antigen-mediated esophageal disease characterized clinically by symptoms related to esophageal dysfunction and histologically by eosinophil-predominant inflammation.<sup>12</sup> This disorder has been given several names including eosinophilic esophagitis, allergic esophagitis, primary eosinophilic esophagitis and idiopathic eosinophilic esophagitis.

#### Etiology

EoE is caused by an abnormal immunologic response to specific antigens. In the vast majority of cases the antigens responsible are food antigens, although there appears to be a contribution from other environmental antigens in certain individuals.<sup>13</sup> While several studies have documented resolution of EoE with

**BOX 45-1 TYPICAL NUMBER OF GASTROINTESTINAL MUCOSAL EOSINOPHILS PER HIGH POWER FIELD IN NORMAL INDIVIDUALS**

- Gastric antrum: <10
- Duodenum: <20
- Colon: 10–20
  - In infants: <10
- Esophagus: 0

strict avoidance of food antigens, in 1995 Kelly et al published the seminal paper on EoE.<sup>14</sup> Because the suspected etiology was an abnormal immunologic response to specific unidentifiable food antigens, each patient was treated with a strict elimination diet which included an amino acid based formula. Patients were also allowed clear liquids, corn and apples. Seventeen patients were initially offered a dietary elimination trial; 10 patients adhered to the protocol. The initial trial was determined by a history of anaphylaxis to specific foods and abnormal skin testing. These patients were subsequently placed on a strict diet consisting of an amino acid based formula for a median of 17 weeks. Symptomatic improvement was seen within an average of 3 weeks after the introduction of the elemental diet (resolution in 8 patients, improvement in 2). In addition, all 10 patients demonstrated a significant improvement in esophageal eosinophilia. All patients reverted to previous symptoms upon reintroduction of foods.

While an exact explanation for this type of response was not determined, Kelly et al suggested an immunologic basis, secondary to a delayed hypersensitivity or a cell-mediated hypersensitivity response, as the cause for EoE. Spergel et al demonstrated that foods that cause EoE do not do so through immediate hypersensitivity reactions.<sup>9</sup> By using a combination of traditional skin prick testing and a lesser used technique of atopy patch testing, they established that a delayed cellular mediated allergic response may be responsible for many cases of EoE. Further supporting a delayed type response, CD8<sup>+</sup> lymphocytes have been identified as the predominant T cell within the squamous epithelium of patients diagnosed with EoE.<sup>15</sup>

A link between EoE and atopy has been established.<sup>10,16</sup> It is these links between atopy and EoE that originally suggested that food allergies play a role in the pathogenesis of this disease. The role of food allergy was confirmed when patients improved on elemental diets. Elimination of the responsible food usually does not lead to rapid resolution of the symptoms. Rather, improvement of symptoms occurs approximately 1 to 2 weeks after the removal of the causative antigen. Also, in patients with EoE, symptoms do not always occur immediately after reintroduction to the foods. It may take several days for symptoms to develop, suggesting either a mixed IgE and T cell mediated allergic response or strictly a T cell delayed mechanism in the pathogenesis of this disease. While both IgE and T cell mediated reactions have been identified as possible causative factors, T cell mediated reactions seem to be the predominant mechanism of disease.<sup>17</sup>

Several authors have suggested that aeroallergens may contribute to the development of EoE. Mishra et al used a mouse model to show that the inhalation of *Aspergillus* caused EoE.<sup>18</sup> They found that the allergen-challenged mice developed elevated levels of esophageal eosinophils and features of

epithelial cell hyperplasia that mimic EoE. In addition, Fogg et al reported a case of a 21-year-old female with asthma and allergic rhinoconjunctivitis who also had EoE.<sup>19</sup> The patient's EoE became symptomatic with exacerbations during pollen seasons, followed by resolution during winter months.

Familial clustering of cases of EoE has led to the assumption that there may be a genetic predisposition to the disease. In recent years, several candidate genes have been identified as risk variants for the development of EoE. Among these are the genes that code for eotaxin-3,<sup>20</sup> thymic stromal lymphoprotein (TSLP)<sup>21</sup> and filaggrin.<sup>22</sup> A genome-wide association approach to identify EoE risk variants was undertaken in two independent EoE and control populations, revealing a single susceptibility locus in both cohorts that corresponded to locus 5q22.1,<sup>21</sup> in which 11 single nucleotide polymorphisms (SNPs) resided within a single haplotype block spanning the *TSLP* gene. *TSLP* has been implicated in the development of atopic disease previously,<sup>23,24</sup> and more recently Noti et al showed that in a mouse model of eosinophilic esophagitis, neutralization with anti-TSLP antibody alleviated tissue eosinophilia associated with disease.<sup>25</sup>

### Clinical Manifestations

Eosinophilic esophagitis can occur in all age groups but traditionally presents in younger patients with a male to female ratio of about 3:1. However, with increased awareness of the disorder among internist-gastroenterologists, there has also been increased recognition of the disorder in adults. Estimates of prevalence are approximately 50 patients per 100,000 population, but EoE appears to be more prevalent in certain populations.

Patients typically present with one or more of the following symptoms: vomiting, regurgitation, nausea, epigastric or chest pain, water brash, globus and/or decreased appetite.<sup>10,26</sup> Less common symptoms include growth failure and hematemesis. Esophageal dysmotility and dysphagia are less common in younger children but become increasingly prevalent in adolescents and adults. Symptoms can be frequent and severe in some patients but extremely intermittent and mild in others. The majority of patients may experience daily dysphagia or chronic nausea or regurgitation while others may have infrequent or rare episodes of dysphagia. Some patients develop coping mechanisms to adapt to their chronic dysphagia including overchewing food, drinking excessively during meals to propel food downward, dipping foods in 'lubricants' such as ketchup or gravy and avoiding meats. It is important for the physician to perform a detailed history of these compensatory mechanisms. Up to 50% of patients manifest additional allergy-related symptoms such as asthma, eczema or rhinitis. Furthermore, more than 50% of patients have one or more parents with history of allergy (Box 45-2).

Children with EoE have been studied in comparison to those with gastroesophageal reflux (GER).<sup>8,9</sup> While the symptoms of vomiting and abdominal pain occurred similarly in both groups, dysphagia, diarrhea and growth failure were predominant in those with EoE (Table 45-1).

### Evaluation and Diagnosis

Patients with chronic refractory symptoms of gastroesophageal reflux disease (GERD) or dysphagia should undergo evaluation for EoE. While laboratory and radiologic assessment may be appropriate, the majority of these patients should undergo an

upper endoscopy with biopsy. Historically, the diagnosis of EoE was often given when an isolated severe histologic esophagitis unresponsive to aggressive acid blockade, associated with symptoms similar to those seen in gastroesophageal reflux disease, was seen.<sup>27</sup> The diagnosis is further supported if the patient responds both clinically and histologically to the elimination of a specific food. In the past, a 24-hour pH probe was required to demonstrate that the esophageal disease was not acid induced; however, more recent guidelines allow for diagnosis in the setting of appropriate clinical and histologic findings. According to the most recent consensus guidelines, the threshold of esophageal eosinophilia should be 15 or more eosinophils per HPF on esophageal biopsies.<sup>12</sup>

However, very high levels of esophageal eosinophilia have been demonstrated with GER alone,<sup>28</sup> emphasizing that failure of appropriate medical therapy is an important feature of the diagnosis. A more recently recognized condition, known as PPI-responsive esophageal eosinophilia (PPI-Ree), has also complicated the diagnostic picture. PPI-Ree was first discovered among cohorts of patients with symptoms and endoscopic and histologic findings characteristic of EoE, in whom all findings normalized after treatment with proton pump inhibitors.<sup>29</sup> For these reasons, where possible, it is preferable to defer endoscopy until after a course of aggressive acid suppression with proton pump inhibitors. At that point, findings of esophageal eosinophilia are more likely to represent true EoE in the appropriate clinical setting. Currently, upper endoscopy with biopsy is the

only diagnostic test that can accurately determine if the esophageal inflammation of EoE is present.

Once EoE is suspected, patients should be encouraged to seek an allergy consultation. Skin prick testing and serum allergen-specific IgE measurements may provide some clues to possible food allergens. Unfortunately, these tests are most useful in determining IgE-based allergic disorders. Since EoE is considered to be either a T cell mediated disease or a mixed IgE and T cell mediated disorder, the sensitivity and specificity of skin prick tests alone are low. Atopy patch testing (the placement of an antigen on the skin for several days followed by assessment for localized skin reaction) may be more useful in determining the antigens responsible for causing esophageal eosinophilia,<sup>9</sup> although this remains to be established. If no specific antigen(s) are found through allergy testing, a trial of an elimination diet, consisting of removal of the antigens that most commonly cause EoE, can be attempted.<sup>30</sup> The most common foods identified as causing EoE are milk, soy, egg and wheat. If all of these measures fail, an elemental diet utilizing an amino acid based formula should be considered. The assessment of success should be based on both the improvement of clinical symptoms and histologic improvement.

Once EoE has resolved, foods should be reintroduced in a systematic manner. Because of the possibility of delayed reactions, it is advisable to wait several days to one week between each new food introduction. This time period is usually sufficient to see a recurrence of symptoms; if symptoms develop, the food should be discontinued. However, in some cases symptoms do not occur despite recurrence of eosinophilic infiltration. A repeat endoscopy with biopsy is required in order to evaluate for the presence of esophageal mucosal injury. Since clinical symptoms often occur sporadically, biopsy remains the most important way to accurately determine the presence or resolution of EoE.

While upper endoscopy with biopsy can precisely determine the diagnosis, noninvasive diagnostic tests have proven to be less useful. These include the evaluation of serum IgE levels and quantitative peripheral eosinophils, radiographic upper gastrointestinal series (UGI), pH probe and manometry, allergen-specific IgE measurements and skin prick and patch testing. A promising new modality is the esophageal string test, where a string is swallowed but then anchored at the mouth so it can be removed and analyzed for the presence of eosinophil-derived proteins. Initial reports show that results from this test correlate strongly with histologic findings of eosinophilia.<sup>31</sup>

EoE should be considered only when the eosinophilia is isolated strictly to the esophagus. To make an accurate diagnosis, the remainder of the gastrointestinal tract must be normal. When EoE is suspected, the sensitivity for detecting the disease is increased when more biopsies are obtained from the

#### BOX 45-2 CHARACTERISTICS OF EOSINOPHILIC ESOPHAGITIS

##### CLINICAL SYMPTOMS

- Similar to symptoms of gastroesophageal reflux disease: vomiting, regurgitation, heartburn, epigastric pain, dysphagia
- Symptoms different in infants and adolescents
- Often intermittent symptoms
- Male > female

##### ASSOCIATED SIGNS AND SYMPTOMS (>50% PATIENTS)

- Bronchospasm
- Eczema
- Allergic rhinitis

##### FAMILY HISTORY (50% PATIENTS)

- Food allergy
- Asthma

TABLE 45-1

**Contrasting Characteristics of Eosinophilic Esophagitis, Gastroesophageal Reflux and Proton Pump Inhibitor Responsive Esophageal Eosinophilia**

	Eosinophilic Esophagitis	Gastroesophageal Reflux	PPI-responsive Esophageal Eosinophilia
Symptoms	Intermittent	Persistent	Intermittent
pH probe	Normal or slightly abnormal	Abnormal	Normal or abnormal
Acid blockade	Unresponsive	Responsive	Responsive
Number of esophageal eosinophils per high-powered field	>5	1–5	>15



esophagus. Sensitivity seems to be highest when at least five biopsies are obtained.<sup>32</sup>

EoE has been associated with visual findings on endoscopy: concentric ring formation called ‘trachealization’ or a ‘feline esophagus’, longitudinal linear furrows and patches of small, white papules on the esophageal surface.<sup>33</sup> Most investigators believe that the esophageal rings and furrows are a response to full thickness esophageal tissue inflammation. The white papules appear to represent the formation of eosinophilic microabscesses (Figures 45-1 and 45-2).

In 2000, Fox et al utilized high-resolution probe endosonography in patients with EoE in order to determine the extent of tissue involvement.<sup>34</sup> They compared eight patients identified with EoE to four control patients without esophagitis and discovered that the layers of the esophageal wall were thicker in EoE patients than in the control group (2.8 to 2.2 mm). Additionally, the mucosa to submucosa ratio (1.6 to 1.1 mm) and the muscularis propria thickness (1.3 to 1.0 mm) were greater in EoE patients. These findings suggested that EoE patients had more than just surface involvement of eosinophils.

### Complications of Disease

While stomach pain, vomiting and failure to thrive are hallmarks of pediatric EoE, food impaction and dysphagia are often found in teenagers diagnosed with EoE.<sup>35</sup> Food impaction prevalence is increasing in parallel with the incidence of EoE.<sup>36</sup> This may be due to the fact that the esophagus in EoE is both more rigid and dysmotile than a normal esophagus. Up to 37% of patients with EoE have been shown to have abnormal esophageal peristalsis,<sup>37</sup> either weak or absent. In addition, the disten-

sibility of the esophagus in EoE patients with a history of food impaction and stricture is decreased.<sup>38</sup>

In addition to food bolus impaction, esophageal stricture is another significant complication of EoE. Esophageal stricture not only causes esophageal dysfunction and dysphagia, but often requires esophageal dilation. There is enhanced collagen deposition in the lamina propria of patients with EoE when compared to patients with GERD.<sup>39</sup> Excessive collagen deposition eventually leads to lumen narrowing and stricture. Stricture formation is part of the natural history of untreated EoE. Adults with longstanding untreated disease are more likely to develop esophageal stricture when compared to those with a relatively short duration of disease.<sup>40</sup> Based on this finding, it is postulated that years of unremitting inflammation eventually lead to excessive esophageal collagen deposition and stricture.

While the pathogenesis of fibrosis in EoE is poorly understood, this complication can lead to decreased quality of life and lifelong dysphagia. Despite successful therapy, patients with EoE continue to have increased lamina propria collagen when compared to control patients. This suggests some degree of permanence in esophageal remodeling,<sup>41</sup> underscoring the importance of prompt diagnosis.

### Management

The identification and removal of allergic dietary antigens is the mainstay of treatment for EoE. While removal of the offending food(s) reverses the disease process in patients with EoE, in many cases the identification of these foods is difficult. Often, patients with EoE cannot correlate their gastrointestinal symptoms with the ingestion of specific foods. Several reports have demonstrated that several days may be required for symptoms to recur upon ingestion of antigens that cause EoE.<sup>14,26</sup> Even when a particular food causing EoE has been eliminated, it may take days or weeks for the symptoms to resolve. In addition,



Rings - 16%

**Figure 45-1** ‘Trachealization’ or ‘feline esophagus’ of the mid-esophagus in a patient with eosinophilic esophagitis. The terms arise from the ringed appearance of the esophagus that cause it to resemble a human trachea or a cat esophagus (which has rings of cartilage).



White plaques - 15%

**Figure 45-2** White plaques seen in the mid-esophagus in a patient with eosinophilic esophagitis.



although one food may be identified, there may be several other foods (not identified) that could also be contributing.

While attempts should be made to identify and eliminate potential food allergens through a careful history and the use of allergy testing, it may be difficult to determine the responsible allergenic foods; the administration of a strict diet, utilizing an amino acid based formula, is often necessary. The use of an elemental diet rapidly improves both clinical symptoms and histology in patients with EoE.<sup>10,14,42</sup> Because of poor palatability, the elemental formula is commonly administered by continuous nasogastric feeding, although some more palatable options have emerged in the last few years. The diet may be supplemented with water, and some have also approved the use of a protein-free single antigen juice such as white grape or apple.

Reversal of symptoms typically occurs within 10 days with histologic improvement within 4 weeks. Although the strict use of an amino acid based formula may initially be difficult for patients (and parents) to accept, its benefits may outweigh the risks of other treatments and the rapid improvement in symptoms proves very reinforcing to families. While the use of other medications, such as corticosteroids, may temporarily improve the disease and its symptoms, the disease recurs upon their discontinuation. In contrast, when foods that cause EoE are identified through a combination of allergy testing, endoscopy, elimination and selective reintroduction, then lifelong remission without medication can be attained.

Treatment of true EoE with aggressive acid blockade, including medical and surgical therapy, has not been proven effective. Several published reports have demonstrated the failure of H<sub>2</sub> blocker and proton pump therapy in patients with EoE.<sup>43,44</sup> While acid blockade may improve clinical symptoms by improving acid reflux that occurs secondary to the underlying inflamed esophageal mucosa, it does not reverse the esophageal histologic abnormality. Although some case reports suggested that fundoplication was beneficial for patients with EoE, in 1997 Liacouras reported on two cases of failed Nissen fundoplication in patients who were diagnosed with severe eosinophilic esophagitis.<sup>45</sup> Both patients underwent fundoplication for presumed acid reflux esophagitis unresponsive to medical therapy. However, post-surgical evaluation of both patients revealed ongoing clinical symptoms. Repeat esophagogastroduodenoscopy demonstrated persistent esophageal eosinophilia. Subsequently, both patients responded to oral corticosteroids with resolution of symptoms and histologic improvement.

Prior to 1997, reports suggested that systemic corticosteroids improved the symptoms of EoE in adults identified with a severe eosinophilic esophagitis.<sup>46,47</sup> In 1997, Liacouras et al were the first to publish the use of oral corticosteroids in 20 children diagnosed with EoE.<sup>44</sup> These patients were treated with oral methylprednisolone (average dose 1.5 mg/kg/day; maximum dose 48 mg/day) for 1 month. Symptoms were significantly improved in 19 of 20 patients by an average of 8 days. A repeat endoscopy with biopsy, 4 weeks after the initiation of therapy, demonstrated a significant reduction of esophageal eosinophils, from 34 to 1.5 eosinophils per HPF. However, upon discontinuation of corticosteroids, 90% had recurrence of symptoms.

In 1999, Faubion et al reported that swallowing a metered dose of aerosolized corticosteroids was also effective in treating the symptoms of EoE in children.<sup>48</sup> Four patients diagnosed with EoE manifested by epigastric pain, dysphagia and a severe esophageal eosinophilia unresponsive to aggressive acid

blockade were given fluticasone, 4 puffs twice a day. Patients were instructed to use an inhaler but to immediately swallow after inhalation in order to deliver the medication to the esophagus. Histologic improvement was not determined. Within 2 months, all 4 patients responded with an improvement in symptoms. Two patients required repeat use of inhalation therapy. Success with this therapy has been confirmed.

Later, Konikoff et al performed a randomized double-blind placebo-controlled trial utilizing swallowed fluticasone in patients with EoE.<sup>49</sup> The study revealed symptom improvement and decreased esophageal eosinophils in those who received the study drug compared to those who received placebo. Aceves et al reported an effective alternative by using liquid budesonide mixed with a sucralose suspension.<sup>50</sup>

Side-effects can include esophageal candidiasis and growth failure.<sup>51,52</sup> As with all therapies that do not involve removal of antigens, symptoms often recur in patients upon discontinuation of the therapy.

Other forms of medical therapy that have been evaluated previously include the mast cell stabilizing agent cromolyn sodium and the leukotriene antagonist montelukast.<sup>53-57</sup> While each of these medications represents an appealing option from a pathophysiologic standpoint, the available data do not support their use, based either upon lack of clinical improvement or minimal to no histologic resolution.

The latest innovation in therapy is the use of biologic agents directed at the cytokine interleukin 5 (IL-5). IL-5 plays an important role in eosinophil recruitment, activation and proliferation. In the past, two small studies demonstrated the effectiveness of anti IL-5 in improving both symptoms and esophageal histology.<sup>58,59</sup> The first large-scale pediatric trial utilizing an anti-IL-5 monoclonal antibody, reslizumab, had mixed results. Patients receiving active drug showed improvement in biopsy findings compared to placebo. However, subjects receiving both active drug and placebo showed symptomatic improvement, which resulted in failure to meet one of the study endpoints required to receive FDA approval.<sup>60</sup> The drug is still in testing for the indication of eosinophilic asthma.

## EOSINOPHILIC GASTROENTERITIS

Eosinophilic gastroenteritis (EoG) is a general term that describes a constellation of symptoms attributable to the gastrointestinal tract, in combination with pathologic infiltration by eosinophils. This group includes eosinophilic gastritis, gastroenteritis and enterocolitis. There are no strict diagnostic criteria for this disorder and it has been largely shaped by multiple case reports and series. A combination of gastrointestinal complaints with supportive histologic findings is sufficient to make the diagnosis. These conditions are grouped together under the term EoG for the discussion here, though it is likely that they are distinct entities in most patients (Box 45-3).

EoG was originally described by Kaijser in 1937.<sup>61</sup> It is a disorder characterized by tissue eosinophilia that can affect different layers of the bowel wall, anywhere from mouth to anus. The gastric antrum and small bowel are most frequently affected. In 1970, Klein et al classified EoG into three categories: a mucosal, muscular and serosal form.<sup>62</sup>

### Etiology

EoG affects patients of all ages, with a slight male predominance. Most commonly, eosinophils infiltrate only the mucosa,

**BOX 45-3 CHARACTERISTICS OF EOSINOPHILIC GASTROENTERITIS**

- Clinical characteristics:
  - nausea, vomiting, regurgitation
  - severe abdominal pain
  - diarrhea, protein losing enteropathy
  - gastrointestinal bleeding
  - ascites
  - intestinal obstruction
- >95% gastric antrum involved
- Peripheral eosinophilia (>50%)
- Associated allergies, eczema, asthma, rhinitis, atopy

leading to symptoms associated with malabsorption such as growth failure, weight loss, diarrhea and hypoalbuminemia. Mucosal EoG may affect any portion of the gastrointestinal tract. A review of the biopsy findings in 38 children with EoG revealed that all patients examined had mucosal eosinophilia of the gastric antrum.<sup>63</sup> Seventy-nine percent of the patients also demonstrated eosinophilia of the proximal small intestine, with 60% having esophageal involvement and 52% having involvement of the gastric corpus. Those with colonic involvement tended to be less than 6 months of age and were ultimately classified as having allergic colitis.

Details of the etiology of EoG remain unknown, although it is now recognized to be a result of both IgE and non-IgE mediated sensitivity.<sup>9</sup> The association between IgE mediated inflammatory response (typical allergy) and EoG is supported by the increased likelihood of other allergic disorders such as atopic disease, food allergies and seasonal allergies.<sup>64,65</sup> Specific foods have been implicated in the cause of EoG in some patients.<sup>66,67</sup> In contrast, the role of non-IgE mediated immune dysfunction, in particular the interplay between lymphocyte-produced cytokines and eosinophils, has received attention. IL-5 is a chemoattractant responsible for tissue eosinophilia.<sup>68</sup> Desreumaux et al found that among patients with EoG, the levels of IL-3, IL-5 and granulocyte-macrophage colony stimulating factor (GM-CSF) were significantly increased as compared to control patients.<sup>69</sup> Once recruited to the tissue, eosinophils may further recruit similar cells through their own production of IL-3 and IL-5, as well as production of leukotrienes.<sup>70</sup> This mixed type of immune dysregulation in EoG has implications for the way this disorder is diagnosed, as well as the way it is treated.

### Clinical Manifestations

The most common symptoms of EoG include colicky abdominal pain, bloating, diarrhea, weight loss, dysphagia and vomiting.<sup>54,71</sup> In addition, up to 50% of patients have a past or family history of atopy.<sup>63</sup> Features of severe disease include gastrointestinal bleeding, iron deficiency anemia, protein losing enteropathy (hypoalbuminemia) and growth failure.<sup>71</sup> Approximately 75% of affected patients have an elevated blood eosinophilia.<sup>70</sup> Males are more commonly affected than females. Rarely, ascites can occur.<sup>72,73</sup>

In an infant, EoG may present in a manner similar to hypertrophic pyloric stenosis, with progressive vomiting, dehydration, electrolyte abnormalities and thickening of the gastric outlet.<sup>74,75</sup> When an infant presents with this constellation of symptoms, in addition to atopic symptoms such as eczema and reactive airway disease, an elevated eosinophil count, or a strong

family history of atopic disease, then EoG should be considered in the diagnosis before surgical intervention.

Uncommon presentations of EoG include acute abdomen (even mimicking acute appendicitis)<sup>76</sup> or colonic obstruction.<sup>77</sup> There have also been reports of serosal infiltration with eosinophils, with associated complaints of abdominal distention, eosinophilic ascites and bowel perforation.<sup>73,78–82</sup>

### Evaluation and Diagnosis

EoG should be considered in any patient with a history of chronic symptoms including vomiting, abdominal pain, diarrhea, anemia, hypoalbuminemia or poor weight gain in combination with the presence of eosinophils in the gastrointestinal tract. Other causes of eosinophilic infiltration of the gastrointestinal tract include the other disorders of the eosinophilic gastroenteropathy spectrum, as well as parasitic infection, inflammatory bowel disease, neoplasm, chronic granulomatous disease, collagen vascular disease and the hypereosinophilic syndrome.<sup>83–87</sup>

A number of tests may aid in the diagnosis of EoG, however no single test is pathognomonic and there are no standards for diagnosis. Eosinophils in the gastrointestinal tract must be documented before EoG can be truly entertained as a diagnosis. This is most readily done with biopsies of either the upper gastrointestinal tract through esophagogastroduodenoscopy or the lower tract through flexible sigmoidoscopy or colonoscopy. A history of atopy supports the diagnosis but is not a necessary feature. Peripheral eosinophilia or an elevated IgE level occurs in approximately 70% of affected individuals.<sup>88</sup> Measures of absorptive activity such as the D-xylose absorption test and lactose hydrogen breath testing may reveal evidence of malabsorption, reflecting small intestinal damage. Radiographic contrast studies may demonstrate mucosal irregularities or edema, wall thickening, ulceration or luminal narrowing. A lacy mucosal pattern of the gastric antrum known as *areae gastricae* is a unique finding that may be present in patients with EoG.<sup>89</sup>

Evaluation of other causes of eosinophilia should be undertaken, including stool analysis for ova and parasites and serologic tests for specific parasites in endemic areas. Signs of intestinal obstruction warrant abdominal imaging. Allergen-specific IgE testing, as well as skin testing for environmental antigens, is rarely useful. Skin testing using both traditional prick tests and patch tests may increase the sensitivity for identifying foods responsible for EoG by evaluating both IgE mediated and T cell mediated sensitivities.<sup>9</sup>

### Management

There is as much ambiguity in the treatment of EoG as there is in its diagnosis. This is in large part because the entity of EoG was defined mainly by case series, each of which employed its own mode of treatment. Since EoG is such a difficult disease to diagnose and relatively rare in prevalence, randomized trials for its treatment are uncommon, leading to considerable debate as to the optimal treatment.

Food allergy is considered one of the potential underlying causes of EoG. The elimination of pathogenic foods, as identified by any form of allergy testing or by random removal of the most likely antigens, should be a first-line consideration. Unfortunately, this approach results in improvement in a limited number of patients. In severe cases, or when other treatment options have failed, the administration of a strict diet, utilizing

an elemental formula, has been shown to be successful.<sup>65,90</sup> In these cases, elemental formula provided as the sole source of nutrition has been reported to be effective in the resolution of clinical symptoms and tissue eosinophilia.

When the use of a restricted or elemental diet fails, corticosteroids are often employed due to their high likelihood of success in attaining remission.<sup>54</sup> However, when weaned, the duration of remission is variable and can be short-lived, leading to the need for repeated courses or continuous low doses of steroids. In addition, the chronic use of corticosteroids carries an increased likelihood of undesirable side-effects, including cosmetic problems (cushingoid facies, hirsutism, acne), decreased bone density, impaired growth and personality changes. A response to these side-effects has been to look for substitutes that may act as steroid-sparing agents, while still allowing for control of symptoms. Anecdotally, immunomodulators more commonly used as steroid-sparing agents in inflammatory bowel disease, such as mercaptopurine or azathioprine, have been used with some success.

Orally administered cromolyn sodium also has been effective in some patients,<sup>54,91-93</sup> and recent reports have detailed the efficacy of other oral antiinflammatory medications. Montelukast, a selective leukotriene receptor antagonist used to treat asthma, has been reported to successfully treat two patients with EoG.<sup>56,94</sup> Treatment of EoG with inhibition of leukotriene D<sub>4</sub>, a potent chemotactic factor for eosinophils, relies on the theory that the inflammatory response in EoG is perpetuated by the presence of the eosinophils already present in the mucosa. This therapy causes an interruption in the chemotactic cascade and breaks the inflammatory cycle. Suplatast tosilate, another suppressor of cytokine production, has also been reported as a treatment for EoG.<sup>95</sup>

Given the possibilities for treatment of EoG, the combination of therapies incorporating the best chance of success with the smallest likelihood of side-effects should be employed. When particular food antigens that may be causing disease can be identified, elimination of those antigens should be first-line therapy. When testing fails to identify potentially pathogenic foods, systematic elimination of the most commonly involved foods<sup>96</sup> can be employed. If this approach fails, a total elimination diet with an amino acid based formula should be considered. Trials of nonsteroidal antiinflammatory medications such as cromolyn, montelukast and suplatast are a reasonable option, although some might prefer to wait for more detailed studies. Monoclonal antibodies against IL-5 may also hold some promise in the future, although current studies are limited to patients with EoE; further research will be necessary in the EoG population.

When other treatments fail, corticosteroids remain a reliable treatment for EoG, with attempts at limiting the total dose or the number of treatment courses where possible. Due to the diffuse and inconsistent nature of symptoms in this disease, serial endoscopy with biopsy is a useful and important modality for monitoring disease progression.

## EOSINOPHILIC PROCTOCOLITIS

Eosinophilic proctocolitis (EoP), also known as allergic proctocolitis or milk protein proctocolitis, has been recognized as one of the most common etiologies of rectal bleeding in infants.<sup>63,97</sup> This disorder is characterized by the onset of rectal bleeding, generally in children less than 2 months of age.

## Etiology

The gastrointestinal tract plays a major role in the development of oral tolerance to foods. Through the process of endocytosis by the enterocyte, food antigens are generally degraded into nonantigenic proteins.<sup>98,99</sup> Although the gastrointestinal tract serves as an efficient barrier to ingested food antigens, this barrier may not be mature for the first few months of life.<sup>100</sup> As a result, ingested antigens may have an increased propensity for being presented intact to the immune system. These intact antigens have the potential to stimulate the immune system and drive an inappropriate response directed at the gastrointestinal tract. Because the major component of the young infant's diet is milk or formula, it stands to reason that the inciting antigens in EoP are derived from the proteins found in them. Cow's milk and soy proteins are the foods most frequently implicated in EoP.

Commercially available infant formulas most commonly utilize cow's milk as the protein source. There are at least 25 known immunogenic proteins within cow's milk, beta-lactoglobulin and the caseins being the most antigenic.<sup>101</sup> It is thought that up to 7.5% of the population in developed countries exhibit cow's milk allergy, although there is wide variation in the reported data.<sup>102-104</sup> Soy protein allergy is considered to be less common than cow's milk allergy, with a reported prevalence of approximately 0.5%.<sup>101</sup> However, soy protein intolerance becomes more prominent in individuals who have developed milk protein allergy, with prevalence from 15% to 50% or more in milk protein sensitized individuals.<sup>105</sup> For this reason, substitution of a soy protein based formula for a milk protein based formula in patients with suspected milk protein proctocolitis is often unsuccessful.

Maternal breast milk represents a different challenge to the immune system. Up to 50% of cases of EoP occur in breastfed infants; however it is thought that, rather than developing an allergy to human milk protein, the infants are manifesting allergy to antigens ingested by the mother and transferred via the breast milk. The transfer of maternal dietary protein via breast milk was first demonstrated in 1921.<sup>106</sup> More recently, the presence of cow's milk antigens in breast milk has been established.<sup>107-109</sup>

When a problem with antigen handling occurs, whether secondary to increased absorption through an immature gastrointestinal tract or through a damaged epithelium secondary to gastroenteritis, sensitization of the immune system results. Once sensitized, the inflammatory response is perpetuated with continued exposure to the inciting antigen. This may explain the reported relationship between early exposure to cow's milk protein or viral gastroenteritis and the development of allergy.<sup>110-112</sup>

## Clinical Manifestations

Diarrhea, rectal bleeding and increased mucus production are the typical symptoms seen in patients who present with EoP.<sup>63,113</sup> There is a bimodal age distribution with the majority of patients presenting in infancy (mean age at diagnosis of 60 days<sup>114</sup>) and the other group presenting in adolescence and early adulthood.

The typical infant with EoP is well appearing with no constitutional symptoms. Rectal bleeding begins gradually, initially appearing as small flecks of blood. Usually, increased stool frequency occurs accompanied by water loss or mucus streaks. The

TABLE 45-2

**Characteristics of Eosinophilic Proctocolitis vs Food Protein Induced Enterocolitis Syndrome (FPIES)**

	Eosinophilic Proctocolitis	FPIES
Appearance	Well	Ill, dehydrated, shocky
Blood streaked stools	Common	Rare
Diarrhea	Mild	Severe
Abdominal pain	Mild to none	Severe
Vomiting	No	Aggressive
Age of onset	<3 months	3–6 months
Failure to thrive	No	Yes
Common foods	Milk, soy	Milk, soy, rice, among others
Laboratory findings	Normal	Anemia, hypoalbuminemia

development of irritability or straining with stools is also common and can falsely lead to the initial assumption of anal fissuring. Atopic symptoms such as eczema and reactive airway disease may be associated. Continued exposure to the inciting antigen causes increased bleeding and may, on rare occasions, cause anemia and poor weight gain. Despite the progression of symptoms, the infants are generally well appearing and rarely appear ill. Other manifestations of gastrointestinal tract inflammation such as vomiting, abdominal distention or weight loss almost never occur and would be suggestive of another problem such as food protein induced enterocolitis syndrome (FPIES) (Table 45-2).

### Evaluation and Diagnosis

EoP is primarily a clinical diagnosis, although several laboratory parameters and diagnostic procedures may be useful. Initial assessment should be directed at the overall health of the child. A toxic appearing infant is not consistent with the diagnosis of EoP and should prompt evaluation for other causes of gastrointestinal bleeding. A complete blood count is useful because the majority of infants with EoP have a normal or borderline low hemoglobin. An elevated serum eosinophil count may be present. Stool studies for bacterial pathogens such as *Salmonella* and *Shigella* should be considered in the setting of rectal bleeding. A stool specimen may be analyzed for the presence of white blood cells, and specifically for eosinophils. The sensitivity of these tests is not well documented, and the absence of a positive finding on these tests does not exclude the diagnosis.<sup>115</sup> Eosinophils can also accumulate in the colon in other conditions such as pinworm and hookworm infections, drug reactions, vasculitis and inflammatory bowel disease, and it is important to exclude these, especially in older children.

Although not always necessary, flexible sigmoidoscopy may be useful to demonstrate the presence of colitis. Visually, one may find erythema, friability or frank ulceration of the colonic mucosa. Alternatively, the mucosa may appear normal, or show evidence of lymphoid hyperplasia.<sup>116,117</sup> Histologic findings typically include increased eosinophils in focal aggregates within the lamina propria, with generally preserved crypt architecture. Findings may be patchy, so care should be taken to examine many levels of each specimen if necessary.<sup>118,119</sup>

### Management

In a well appearing patient with a history consistent with EoP, it is acceptable to make an empiric change in the protein source of the formula. Because of the frequent development of soy protein EoP in milk-sensitized individuals, a protein hydrolysate formula is often the best choice.<sup>111</sup> Resolution of symptoms begins almost immediately after the elimination of the problematic food. Although symptoms may linger for several days to weeks, continued improvement is the rule. If symptoms do not quickly improve, or persist beyond 4 to 6 weeks, other antigens should be considered, as well as other potential causes of rectal bleeding. In breastfed infants, dietary restriction of milk and soy containing products from the mother's diet may result in improvement; however, care should be taken to ensure that the mother maintains adequate protein and calcium intake from other sources.

EoP in infancy is generally benign and withdrawing the milk protein trigger resolves the condition. Though gross blood in the stool usually disappears within 72 hours, occult blood loss may persist for longer.<sup>114</sup> The prognosis is excellent and the majority of patients are able to tolerate the culprit milk protein by 1 to 3 years of age. In older individuals it is more difficult to identify the food triggers and therefore patients usually require medical management. Though there is a paucity of clinical data regarding therapy for this condition, it appears that glucocorticoids and aminosalicylates are efficacious.<sup>6</sup> The prognosis for older onset EoP is less favorable than the infant presentation and is typically chronic and relapsing.

### OTHER MANIFESTATIONS OF GASTROINTESTINAL ALLERGY

Although we have described several specific manifestations of allergic bowel disease in the sections above, there remain numerous nonspecific complaints that may occur in the infant that have also been linked to food allergy. These nonspecific complaints create an especially difficult situation for the practitioner, as only a proportion of infants with these complaints will have them as a result of allergy. Further, there are no specific findings that, independently, can confirm or exclude the diagnosis. Among these potential nonspecific manifestations are gastroesophageal reflux, colic, constipation and diarrhea.

#### Gastroesophageal Reflux

Gastroesophageal reflux (GER) is a common complaint among infants, children and adults. Up to two thirds of 4-month-old infants experience regurgitation on a daily basis,<sup>120</sup> with other complaints such as forceful vomiting, arching, irritability and feeding refusal occurring to varying degrees. Furthermore, many infants and children may experience GER without the presence of any overt signs or symptoms. Most cases of GER are not attributable to a specific underlying cause; however, one of the leading identifiable causes of GER in this population is food allergy.<sup>121,122</sup>

The association between GER and cow's milk allergy (CMA) was prospectively investigated.<sup>122</sup> In a 3-year prospective study, infants with symptoms compatible with GER underwent pH monitoring and endoscopy to confirm the presence of GER. Patients with a reflux index (percentage of time with acid reflux) of greater than 5% and the presence of esophagitis were considered to have GER. The presence of CMA in these patients



was assessed using skin prick tests, by the presence of eosinophils in fecal mucus, nasal mucus or peripheral blood, and by circulating levels of anti-beta-lactoglobulin IgG. Patients who had positive assays for CMA and GER were placed on a cow's milk restricted diet with a protein hydrolysate formula. After 3 months, a double-blind cow's milk challenge was performed to confirm the diagnosis of CMA. This stringent method of diagnosing both GER and CMA revealed a surprisingly high prevalence (42%) of patients with GER who also had CMA. Further, this author group went on to show that 14 of 47 patients (30%) had GER that was attributable to the CMA itself, based on resolution of symptoms on a restricted diet followed by return of symptoms when re-challenged. Whether cow's milk or other food allergies are responsible for such a high proportion of GER in all populations remains to be seen; however these results imply that refractory cases of GER warrant consideration of food allergy as a contributing factor.

### *Infantile Colic*

Infantile colic is a term that is generally used to describe acute self-limited episodes of irritability (presumably due to abdominal pain) that occur in otherwise healthy infants in the first several months of life.<sup>123</sup> Although the labeling of an infant as having 'colic' implies there is no organic disease responsible, a subset of infants diagnosed with colic will have an underlying organic cause. Food allergies, and specifically CMA, have been highly implicated in the organic etiologies of infantile colic.

Traditionally, changing the infant's formula is a common way of dealing with colic; often several formula changes are made (e.g. from cow's milk based to soy based to hydrolyzed protein). It is often unclear, however, whether the formula change is responsible for the eventual resolution of symptoms, as colic by definition begins to resolve by 4 to 5 months of age.

### *Diarrhea*

The presence of diarrhea in the context of food allergies can be multifactorial. As discussed in previous sections, eosinophilic gastroenteritis (EoG) and eosinophilic proctitis (EoP) may both lead to intestinal mucosal damage and subsequent diarrhea. However, food allergy may also result in diarrhea in the absence of mucosal damage or eosinophilic infiltration.

Gastrointestinal symptoms, in particular diarrhea, are commonly seen among children with atopic eczema,<sup>124,125</sup> avoidance of particular foods in these patients will alleviate the symptoms.<sup>125</sup> In patients with gastrointestinal symptoms related to milk ingestion (confirmed by double-blind challenge), the instillation of milk into the intestinal lumen resulted in increased production of histamine and eosinophil cationic protein within 20 minutes.<sup>126</sup> Albumin concentration in the intestine also increased, suggesting increased gut permeability and leakage; none of these findings were seen in normal controls.

### *Constipation*

Constipation is a common problem among infants and children, and although often short-lived or self-limited, a substantial proportion may have symptoms that persist for 6 months or more.<sup>127</sup> It has long been suggested that cow's milk plays a role in the development of chronic constipation,<sup>128</sup> and there is evidence that CMA is a causative factor. One of the most compelling studies involved a blinded cross-over study of cow's milk restriction in children with chronic constipation.<sup>129</sup> In this trial, 65 children with chronic constipation (all of whom received

cow's milk in their regular diet) were randomized to receive either cow's milk or soy milk for 15 days, followed by a washout period and reversal of the previous diet. Sixty-eight percent of the children had improvement in their constipation while taking soy milk, while none had improvement on cow's milk. Re-challenging the responders with cow's milk resulted in return of constipation. Evidence of CMA was based upon higher frequencies of co-existing rhinitis, dermatitis and bronchospasm in responders, as well as increased likelihood of elevated IgE to cow's milk antigens and inflammatory cells on rectal biopsy. A subsequent study revealed further evidence of the causative nature of CMA in constipation.<sup>130</sup>

## **Approach to the Potentially Allergic Infant with Nonspecific Gastrointestinal Symptoms**

Because gastrointestinal complaints such as those listed in the section 'Other Manifestations of Gastrointestinal Allergy' are quite common in the infant population, the practitioner who cares for infants will commonly be faced with the issue of when to implicate food allergy. Further complicating the issue is that general allergic complaints such as atopic eczema and rhinitis are also quite common in this population. Optimally, the allergic contribution to any gastrointestinal complaint would be investigated through double-blind food challenges. However, this is not practical for most practitioners.

Any infant with gastrointestinal symptoms refractory to standard treatment may be manifesting signs of food allergy. Because CMA is implicated most commonly in this population, removal of this antigen from the diet is a reasonable approach. However, this change should be made in concert with appropriate investigations for other etiologic factors (e.g. anatomic studies such as upper gastrointestinal series in chronic reflux, stool cultures in chronic diarrhea). Soy formula may be substituted for cow's milk formula, although hypersensitivity to both milk and soy protein is not uncommon. Protein hydrolysate formulas represent a good option, more likely to result in improvement in a truly allergic infant. Breastfeeding mothers may need to restrict their intake of milk and soy for several weeks before the antigens no longer appear in breast milk. The use of amino acid based elemental formulas should be reserved for those who have failed hydrolyzed protein formulas and, preferably, those who have some other objective positive findings of allergy. It should be remembered that the natural history of allergy in the infant is often self-limited, and thus improvement with dietary elimination does not independently confirm food allergy. Formally re-challenging the infant with the suspected food antigen is a better way to confirm that allergy existed and was responsible for the symptoms in question. Formal consultation with an allergist in this context is highly advisable.

## **Conclusion**

Eosinophilic disorders of the gastrointestinal tract are becoming increasingly recognized as distinct clinical entities with specific management strategies. While EoG is rare and difficult to diagnose, EoP and EoE are much more common and easily diagnosed by endoscopic biopsy. While EoP is a well accepted entity, the diagnosis of EoE has recently been receiving a great

deal of attention. Recent literature suggests a mini-epidemic of EoE in the pediatric population, though controversy still exists regarding the etiology and treatment.

Future research should focus on clarifying the prevalence and natural history (e.g. the potential development of strictures) and optimizing the diagnostic approach and treatment options of all gastrointestinal eosinophilic disorders. The particular management challenges posed by these conditions warrant close liaison between gastroenterologists, allergists and dietitians. In addition, patients and families require particular support, especially when trying to adopt restricted diets. Patient-founded, support advocacy groups have been established for this purpose (e.g. American Partnership for Eosinophilic Disorders, [www.APFED.org](http://www.APFED.org)).

Awareness of food-induced allergic and eosinophilic disease of the gastrointestinal tract has increased, but many unan-

swered questions remain. The variation in geographic distribution of EoG and EoE has yet to be explained. The pathogenesis of these conditions has to be fully elucidated, in particular the role of environmental and infectious agents. Advances need to be made in diagnosing these conditions, especially with the use of less invasive techniques than endoscopy with biopsy, and also in better identifying offending food antigens and allergens. In addition, biochemical studies need to be pursued so that we can determine a cause of these disorders. Is the eosinophil dysregulation due to an immunologic defect or an allergy? These and other research questions reinforce the limitations of our current understanding of gastrointestinal eosinophilic disease.

The complete reference list can be found on the companion Expert Consult website at <http://www.expertconsult.inkling.com>.

## KEY REFERENCES

6. Rothenberg ME. Eosinophilic gastrointestinal disorders (EGID). *J Allergy Clin Immunol* 2004;113:11–28, quiz 29.
12. Liacouras CA, Furuta GT, Hirano I, Atkins D, Attwood SE, Bonis PA, et al. Eosinophilic esophagitis: updated consensus recommendations for children and adults. *J Allergy Clin Immunol* 2011;128:3–20, e6.
15. Teitelbaum JE, Fox VL, Twarog FJ, Yardley JH, Perman JA, Sampson HA. Eosinophilic esophagitis in children: immunopathological analysis and response to fluticasone propionate. *Gastroenterology* 2002;122:1216–25.
25. Noti M, Wojno EDT, Kim BS, Siracusa MC, Giacomini PR, Nair MG, et al. Thymic stromal lymphopoietin-elicited basophil responses promote eosinophilic esophagitis. *Nat Med* 2013;19:1005–13.
30. Kagalwalla AF, Sentongo TA, Ritz S, Hess T, Nelson SP, Emerick KM, et al. Effect of six-food elimination diet on clinical and histologic outcomes in eosinophilic esophagitis. *Clin Gastroenterol Hepatol* 2006;4:1097–102.
40. Schoepfer AM, Safroneeva E, Bussmann C, Kuchen T, Portmann S, Simon H-U, et al. Delay in Diagnosis of eosinophilic esophagitis increases risk for stricture formation, in a time-dependent Manner. *Gastroenterology* 2013;145:1230–6.
42. Markowitz J. Elemental diet is an effective treatment for eosinophilic esophagitis in children and adolescents. *Am J Gastroenterol* 2003;98:777–82.
49. Konikoff MR, Noel RJ, Blanchard C, Kirby C, Jameson SC, Buckmeier BK, et al. A randomized, double-blind, placebo-controlled trial of fluticasone propionate for pediatric eosinophilic esophagitis. *Gastroenterology* 2006;131:1381–91.
99. Husby S, Høst A, Teisner B, Svehag SE. Infants and children with cow milk allergy/intolerance. Investigation of the uptake of cow milk protein and activation of the complement system. *Allergy* 1990;45:547–51.
121. Iacono G, Carroccio A, Cavataio F, Montalto G, Kazmierska I, Lorello D, et al. Gastroesophageal reflux and cow's milk allergy in infants: a prospective study. *J Allergy Clin Immunol* 1996;97:822–7.

## REFERENCES

- Sampson HA. Differential diagnosis in adverse reactions to foods. *J Allergy Clin Immunol* 1986;78:212–19.
- Bock SA, Atkins FM. Patterns of food hypersensitivity during sixteen years of double-blind, placebo-controlled food challenges. *J Pediatr* 1990;117:561–7.
- Atkins FM, Steinberg SS, Metcalfe DD. Evaluation of immediate adverse reactions to foods in adult patients. II. A detailed analysis of reaction patterns during oral food challenge. *J Allergy Clin Immunol* 1985;75:356–63.
- Sampson HA. IgE-mediated food intolerance. *J Allergy Clin Immunol* 1988;81:495–504.
- Heine RG. Pathophysiology, diagnosis and treatment of food protein-induced gastrointestinal diseases. *Curr Opin Allergy Clin Immunol* 2004;4:221–9.
- Rothenberg ME. Eosinophilic gastrointestinal disorders (EGID). *J Allergy Clin Immunol* 2004;113:11–28, quiz 29.
- Guajardo JR, Plotnick LM, Fende JM, Collins MH, Putnam PE, Rothenberg ME. Eosinophil-associated gastrointestinal disorders: a world-wide-web based registry. *J Pediatr* 2002;141:576–81.
- Walsh SV, Antonioli DA, Goldman H, Fox VL, Bousvaros A, Leichtner AM, et al. Allergic esophagitis in children: a clinicopathological entity. *Am J Surg Pathol* 1999;23:390–6.
- Spergel JM, Beausoleil JL, Mascarenhas M, Liacouras CA. The use of skin prick tests and patch tests to identify causative foods in eosinophilic esophagitis. *J Allergy Clin Immunol* 2002;109:363–8.
- Liacouras CA, Spergel JM, Ruchelli E, Verma R, Mascarenhas M, Semeao E, et al. Eosinophilic esophagitis: a 10-year experience in 381 children. *Clin Gastroenterol Hepatol* 2005;3:1198–206.
- Sampson HA. Food allergy. Part 1: immunopathogenesis and clinical disorders. *J Allergy Clin Immunol* 1999;103:717–28.
- Liacouras CA, Furuta GT, Hirano I, Atkins D, Attwood SE, Bonis PA, et al. Eosinophilic esophagitis: updated consensus recommendations for children and adults. *J Allergy Clin Immunol* 2011;128:3–20, e6.
- Sugnam KK, Collins JT, Smith PK, Connor E, Lewindon P, Cleghorn G, et al. Dichotomy of food and inhalant allergen sensitization in eosinophilic esophagitis. *Allergy* 2007;62:1257–60.
- Kelly KJ, Lazenby AJ, Rowe PC, Yardley JH, Perman JA, Sampson HA. Eosinophilic esophagitis attributed to gastroesophageal reflux: improvement with an amino acid-based formula. *Gastroenterology* 1995;109:1503–12.
- Teitelbaum JE, Fox VL, Twarog FJ, Yardley JH, Perman JA, Sampson HA. Eosinophilic esophagitis in children: immunopathological analysis and response to fluticasone propionate. *Gastroenterology* 2002;122:1216–25.
- Roy-Ghanta S, Larosa DF, Katzka DA. Atopic characteristics of adult patients with eosinophilic esophagitis. *Clin Gastroenterol Hepatol* 2008;6:531–5.
- Merves J, Muir A, Modayur-Chandramouleeswaran P, Cianferoni A, Wang ML, Spergel JM. Eosinophilic esophagitis. *Ann Allergy Asthma Immunol* 2014;112:397–403.
- Mishra A, Hogan SP, Brandt EB, Rothenberg ME. An etiological role for aeroallergens and eosinophils in experimental esophagitis. *J Clin Invest* 2001;107:83–90.
- Fogg MI, Ruchelli E, Spergel JM. Pollen and eosinophilic esophagitis. *J Allergy Clin Immunol* 2003;112:796–7.
- Blanchard C, Wang N, Stringer KF, Mishra A, Fulkerson PC, Abonia JP, et al. Eotaxin-3 and a uniquely conserved gene-expression profile in eosinophilic esophagitis. *J Clin Invest* 2006;116:536–47.
- Rothenberg ME, Spergel JM, Sherrill JD, Annaiah K, Martin LJ, Cianferoni A, et al. Common variants at 5q22 associate with pediatric eosinophilic esophagitis. *Nat Genet* 2010;42:89–91.
- Blanchard C, Stucke EM, Burwinkel K, Caldwell JM, Collins MH, Ahrens A, et al. Coordinate interaction between IL-13 and epithelial differentiation cluster genes in eosinophilic esophagitis. *J Immunol* 2010;184:4033–41.
- Zhou B, Comeau MR, De Smedt T, Liggitt HD, Dahl ME, Lewis DB, et al. Thymic stromal lymphopoietin as a key initiator of allergic airway inflammation in mice. *Nat Immunol* 2005;6:1047–53.
- Wong CK, Hu S, Cheung PFY, Lam CW. Thymic stromal lymphopoietin induces chemotactic and pro-survival effects in eosinophils: implications in allergic inflammation. *Am J Respir Cell Mol Biol* 2010;43:305–15.
- Noti M, Wojno EDT, Kim BS, Siracusa MC, Giacomini PR, Nair MG, et al. Thymic stromal lymphopoietin-elicited basophil responses promote eosinophilic esophagitis. *Nat Med* 2013;19:1005–13.
- Liacouras CA, Markowitz JE. Eosinophilic esophagitis: a subset of eosinophilic gastroenteritis. *Curr Gastroenterol Rep* 1999;1:253–8.
- Furuta GT, Liacouras CA, Collins MH, Gupta SK, Justinich C, Putnam PE, et al. Eosinophilic esophagitis in children and adults: a systematic review and consensus recommendations for diagnosis and treatment. *Gastroenterology* 2007;133:1342–63.
- Ngo P, Furuta GT, Antonioli DA, Fox VL. Eosinophils in the esophagus – peptic or allergic eosinophilic esophagitis? Case series of three patients with esophageal eosinophilia. *Am J Gastroenterol* 2006;101:1666–70.
- Molina-Infante J, Ferrando-Lamana L, Ripoll C, Hernandez-Alonso M, Mateos JM, Fernandez-Bermejo M, et al. Esophageal eosinophilic infiltration responds to proton pump inhibition in most adults. *Clin Gastroenterol Hepatol* 2011;9:110–17.
- Kagalwalla AF, Sentongo TA, Ritz S, Hess T, Nelson SP, Emerick KM, et al. Effect of six-food elimination diet on clinical and histologic outcomes in eosinophilic esophagitis. *Clin Gastroenterol Hepatol* 2006;4:1097–102.
- Furuta GT, Kagalwalla AF, Lee JJ, Alumkal P, Maybruck BT, Fillon S, et al. The oesophageal string test: a novel, minimally invasive method measures mucosal inflammation in eosinophilic oesophagitis. *Gut* 2013;62:1395–405.
- Gonsalves N, Policarpio-Nicolas M, Zhang Q, Rao MS, Hirano I. Histopathologic variability and endoscopic correlates in adults with eosinophilic esophagitis. *Gastrointest Endosc* 2006;64:313–19.
- Orenstein SR, Shalaby TM, Di Lorenzo C, Putnam PE, Sigurdsson L, Mousa H, et al. The spectrum of pediatric eosinophilic esophagitis beyond infancy: a clinical series of 30 children. *Am J Gastroenterol* 2000;95:1422–30.
- Fox VL, Nurko S, Teitelbaum JE, Badizadegan K, Furuta GT. High-resolution EUS in children with eosinophilic ‘allergic’ esophagitis. *Gastrointest Endosc* 2003;57:30–6.
- Noel RJ, Putnam PE, Rothenberg ME. Eosinophilic esophagitis. *N Engl J Med* 2004;351:940–1.
- Sperry SL, Crockett SD, Miller CB, Shaheen NJ, Dellon ES. Esophageal foreign-body impactions: epidemiology, time trends, and the impact of the increasing prevalence of eosinophilic esophagitis. *Gastrointest Endosc* 2011;74:985–91. Available at: <<http://linkinghub.elsevier.com/retrieve/pii/S0016510711019110>>.
- Roman S, Hirano I, Kwiatek MA, Gonsalves N, Chen J, Kahrilas PJ, et al. Manometric features of eosinophilic esophagitis in esophageal pressure topography. *Neurogastroenterol Motil* 2011;23:208–14, e111.
- Nicodème F, Hirano I, Chen J, Robinson K, Lin Y, Xiao Y, et al. Esophageal distensibility as a measure of disease severity in patients with eosinophilic esophagitis. *Clin Gastroenterol Hepatol* 2013;11:1101–7, e1.
- Aceves SS, Newbury RO, Dohil R, Bastian JE, Broide DH. Esophageal remodeling in pediatric eosinophilic esophagitis. *J Allergy Clinical Immunol* 2007;119:206–12.
- Schoepfer AM, Safroneeva E, Bussmann C, Kuchen T, Portmann S, Simon H-U, et al. Delay in Diagnosis of eosinophilic esophagitis increases risk for stricture formation, in a time-dependent Manner. *Gastroenterology* 2013;145:1230–6.
- Lucendo AJ, Arias A, De Rezende LC, Yague-Compadre JL, Mota-Huertas T, Gonzalez-Castillo S, et al. Subepithelial collagen deposition, profibrogenic cytokine gene expression, and changes after prolonged fluticasone propionate treatment in adult eosinophilic esophagitis: a prospective study. *J Allergy Clin Immunol* 2011;128:1037–46.
- Markowitz J. Elemental diet is an effective treatment for eosinophilic esophagitis in children and adolescents. *Am J Gastroenterol* 2003;98:777–82.
- Ruchelli E, Wenner W, Voytek T, Brown K, Liacouras C. Severity of esophageal eosinophilia predicts response to conventional gastroesophageal reflux therapy. *Pediatr Dev Pathol* 1999;2:15–18.
- Liacouras CA, Wenner WJ, Brown K, Ruchelli E. Primary eosinophilic esophagitis in children: successful treatment with oral corticosteroids. *J Pediatr Gastroenterol Nutr* 1998;26:380–5.
- Liacouras CA. Failed Nissen fundoplication in two patients who had persistent vomiting and eosinophilic esophagitis. *J Pediatr Surg* 1997;32:1504–6.
- Vitellas KM, Bennett WF, Bova JG, Johnston JC, Caldwell JH, Mayle JE. Idiopathic eosinophilic esophagitis. *Radiology* 1993;186:789–93.
- Lee RG. Marked eosinophilia in esophageal mucosal biopsies. *Am J Surg Pathol* 1985;9:475–9.
- Faubion WA, Perrault J, Burgart LJ, Zein NN, Clawson M, Freese DK. Treatment of eosinophilic esophagitis with inhaled corticosteroids. *J Pediatr Gastroenterol Nutr* 1998;27:90–3.

49. Konikoff MR, Noel RJ, Blanchard C, Kirby C, Jameson SC, Buckmeier BK, et al. A randomized, double-blind, placebo-controlled trial of fluticasone propionate for pediatric eosinophilic esophagitis. *Gastroenterology* 2006;131:1381–91.
50. Aceves SS, Bastian JF, Newbury RO, Dohil R. Oral viscous budesonide: a potential new therapy for eosinophilic esophagitis in children. *Am J Gastroenterol* 2007;102:2271–9, quiz 2280.
51. Simon MR, Houser WL, Smith KA, Long PM. Esophageal candidiasis as a complication of inhaled corticosteroids. *Ann Allergy Asthma Immunol* 1997;79:333–8.
52. Sharek PJ, Bergman DA. The effect of inhaled steroids on the linear growth of children with asthma: a meta-analysis. *Pediatrics* 2000;106:E8.
53. Dahl R. Disodium cromoglycate and food allergy. The effect of oral and inhaled disodium cromoglycate in a food allergic patient. *Allergy* 1978;33:120–4.
54. Whittington PF, Whittington GL. Eosinophilic gastroenteropathy in childhood. *J Pediatr Gastroenterol Nutr* 1988;7:379–85.
55. Businco L, Cantani A. Food allergy in children: diagnosis and treatment with sodium cromoglycate. *Allergol Immunopathol (Madr)* 1990;18:339–48.
56. Schwartz DA, Pardi DS, Murray JA. Use of montelukast as steroid-sparing agent for recurrent eosinophilic gastroenteritis. *Dig Dis Sci* 2001;46:1787–90.
57. Attwood SE, Lewis CJ, Bronder CS, Morris CD, Armstrong GR, Whittam J. Eosinophilic esophagitis: a novel treatment using Montelukast. *Gut* 2003;52:181–5.
58. Garrett JK, Jameson SC, Thomson B, Collins MH, Wagoner LE, Freese DK, et al. Anti-interleukin-5 (mepolizumab) therapy for hypereosinophilic syndromes. *J Allergy Clin Immunol* 2004;113:115–19.
59. Stein ML, Collins MH, Villanueva JM, Kushner JP, Putnam PE, Buckmeier BK, et al. Anti-IL-5 (mepolizumab) therapy for eosinophilic esophagitis. *J Allergy Clin Immunol* 2006;118:1312–19.
60. Spergel JM, Rothenberg ME, Collins MH, Furuta GT, Markowitz JE, Fuchs G 3rd, et al. Reslizumab in children and adolescents with eosinophilic esophagitis: results of a double-blind, randomized, placebo-controlled trial. *J Allergy Clinical Immunol* 2012;129:456–63, e3.
61. Kaijser R. Zur Kenntnis der allergischen Affektion der desmia Verdeanungskanal von Standpunkt desmia Chirurgen aus. *Arch Klin Chir* 1937;188:36–64.
62. Klein NC, Hargrove RL, Slesinger MH, Jeffries GH. Eosinophilic gastroenteritis. *Medicine (Baltimore)* 1970;49:299–319.
63. Goldman H, Proujansky R. Allergic proctitis and gastroenteritis in children. Clinical and mucosal biopsy features in 53 cases. *Am J Surg Pathol* 1986;10:75–86.
64. Park HS, Kim HS, Jang HJ. Eosinophilic gastroenteritis associated with food allergy and bronchial asthma. *J Korean Med Sci* 1995;10:216–19.
65. Justinich C, Katz A, Gurbindo C, Lepage G, Chad Z, Bouthillier L, et al. Elemental diet improves steroid-dependent eosinophilic gastroenteritis and reverses growth failure. *J Pediatr Gastroenterol Nutr* 1996;23:81–5.
66. Leinbach GE, Rubin CE. Eosinophilic gastroenteritis: a simple reaction to food allergens? *Gastroenterology* 1970;59:874–89.
67. Caldwell JH, Sharma HM, Hurtubise PE, Colwell DL. Eosinophilic gastroenteritis in extreme allergy. Immunopathological comparison with nonallergic gastrointestinal disease. *Gastroenterology* 1979;77:560–4.
68. Kelso A. Cytokines: structure, function and synthesis. *Curr Opin Immunol* 1989;2:215–25.
69. Desreumaux P, Bloget F, Seguy D, Capron M, Cortot A, Colombel JF, et al. Interleukin 3, granulocyte-macrophage colony-stimulating factor, and interleukin 5 in eosinophilic gastroenteritis. *Gastroenterology* 1996;110:768–74.
70. Takafuji S, Bischoff SC, De Weck AL, Dahinden CA. IL-3 and IL-5 prime normal human eosinophils to produce leukotriene C4 in response to soluble agonists. *J Immunol* 1991;147:3855–61.
71. Kelly KJ. Eosinophilic gastroenteritis. *J Pediatr Gastroenterol Nutr* 2000;30(Suppl.):S28–35.
72. Talley NJ, Shorter RG, Phillips SF, Zinsmeister AR. Eosinophilic gastroenteritis: a clinicopathological study of patients with disease of the mucosa, muscle layer, and subserosal tissues. *Gut* 1990;31:54–8.
73. Santos J, Junquera F, de Torres I, et al. Eosinophilic gastroenteritis presenting as ascites and splenomegaly. *Eur J Gastroenterol Hepatol* 1995;7:675–8.
74. Aquino A, Dòmini M, Rossi C, Molero X, Vilaseca J, Malagelada JR. Pyloric stenosis due to eosinophilic gastroenteritis: presentation of two cases in mono-ovular twins. *Eur J Pediatr* 1999;158:172–3.
75. Bryan SA, O'Connor BJ, Matti S, Leckie MJ, Kanabar V, Khan J, et al. Effects of recombinant human interleukin-12 on eosinophils, airway hyper-responsiveness, and the late asthmatic response. *Lancet* 2000;356:2149–53.
76. Khan S, Orenstein SR. Eosinophilic gastroenteritis masquerading as pyloric stenosis. *Clin Pediatr (Phila)* 2000;39:55–7.
77. Shweiki E, West JC, Klena JW, Kelley SE, Colley AT, Bross RJ, et al. Eosinophilic gastroenteritis presenting as an obstructing cecal mass – a case report and review of the literature. *Am J Gastroenterol* 1999;94:3644–5.
78. Huang FC, Ko SF, Huang SC, Lee SY. Eosinophilic gastroenteritis with perforation mimicking intussusception. *J Pediatr Gastroenterol Nutr* 2001;33:613–15.
79. Deslandres C, Russo P, Gould P, Hardy P. Perforated duodenal ulcer in a pediatric patient with eosinophilic gastroenteritis. *Can J Gastroenterol* 1997;11:208–12.
80. Wang CS, Hsueh S, Shih LY, Chen MF. Repeated bowel resections for eosinophilic gastroenteritis with obstruction and perforation. Case report. *Acta Chir Scand* 1990;156:333–6.
81. Hoefler RA, Ziegler MM, Koop CE, Schnauffer L. Surgical manifestations of eosinophilic gastroenteritis in the pediatric patient. *J Pediatr Surg* 1977;12:955–62.
82. Lerza P. A further case of eosinophilic gastroenteritis with ascites. *Eur J Gastroenterol Hepatol* 1996;8:407.
83. DeSchryver-Kecskemeti K, Clouse RE. A previously unrecognized subgroup of 'eosinophilic gastroenteritis.' Association with connective tissue diseases. *Am J Surg Pathol* 1984;8:171–80.
84. Dubucquoi S, Janin A, Klein O, Desreumaux P, Quandalle P, Cortot A, et al. Activated eosinophils and interleukin 5 expression in early recurrence of Crohn's disease. *Gut* 1995;37:242–6.
85. Levy AM, Yamazaki K, Van Keulen VP, Burgart LJ, Sandborn WJ, Phillips SF, et al. Increased eosinophil infiltration and degranulation in colonic tissue from patients with collagenous colitis. *Am J Gastroenterol* 2001;96:1522–8.
86. Griscom NT, Kirkpatrick JA, Girdany BR, Berdon WE, Grand RJ, Mackie GG. Gastric antral narrowing in chronic granulomatous disease of childhood. *Pediatrics* 1974;54:456–60.
87. Harris BH, Boles ET. Intestinal lesions in chronic granulomatous disease of childhood. *J Pediatr Surg* 1973;8:955–6.
88. Caldwell JH, Tennenbaum JI, Bronstein HA. Serum IgE in eosinophilic gastroenteritis. Response to intestinal challenge in two cases. *N Engl J Med* 1975;292:1388–90.
89. Teele RL, Katz AJ, Goldman H, Kettell RM. Radiographic features of eosinophilic gastroenteritis (allergic gastroenteropathy) of childhood. *AJR Am J Roentgenol* 1979;132:575–80.
90. Vandenplas Y, Quenon M, Renders F, Dab I, Loeb H. Milk-sensitive eosinophilic gastroenteritis in a 10-day-old boy. *Eur J Pediatr* 1990;149:244–5.
91. Van Dellen RG, Lewis JC. Oral administration of cromolyn in a patient with protein-losing enteropathy, food allergy, and eosinophilic gastroenteritis. *Mayo Clin Proc* 1994;69:441–4.
92. Moots RJ, Prouse P, Gumpel JM. Near fatal eosinophilic gastroenteritis responding to oral sodium cromoglycate. *Gut* 1988;29:1282–5.
93. Di Gioacchino M, Pizzicannella G, Fini N, Falasca F, Antinucci R, Masci S, et al. Sodium cromoglycate in the treatment of eosinophilic gastroenteritis. *Allergy* 1990;45:161–6.
94. Neustrom MR, Friesen C. Treatment of eosinophilic gastroenteritis with montelukast. *J Allergy Clin Immunol* 1999;104:506.
95. Shirai T, Hashimoto D, Suzuki K, Osawa S, Aonahata M, Chida K, et al. Successful treatment of eosinophilic gastroenteritis with suplatast tosilate. *J Allergy Clin Immunol* 2001;107:924–5.
96. Bengtsson U, Hanson LA, Ahlstedt S. Survey of gastrointestinal reactions to foods in adults in relation to atopy, presence of mucus in the stools, swelling of joints and arthralgia in patients with gastrointestinal reactions to foods. *Clin Exp Allergy* 1996;26:1387–94.
97. Jenkins HR, Pincott JR, Soothill JF, Milla PJ, Harries JT. Food allergy: the major cause of infantile colitis. *Arch Dis Child* 1984;59:326–9.
98. Heyman M, Grasset E, Ducroc R, Desjeux JF. Antigen absorption by the jejunal epithelium of children with cow's milk allergy. *Pediatr Res* 1988;24:197–202.
99. Husby S, Høst A, Teisner B, Svehag SE. Infants and children with cow milk allergy/intolerance. Investigation of the uptake of cow milk protein and activation of the complement system. *Allergy* 1990;45:547–51.
100. Kerner JA. Formula allergy and intolerance. *Gastroenterol Clin North Am* 1995;24:1–25.
101. Simpsen E. Gastrointestinal allergy. In: Altschuler SM, editor. *Clinical pediatric gastroenterology*. London: Elsevier Health; 1998. p. 113–18.



102. Gerrard JW, MacKenzie JW, Goluboff N, Garson JZ, Maningas CS. Cow's milk allergy: prevalence and manifestations in an unselected series of newborns. *Acta Paediatr Scand Suppl* 1973;234:1–21.
103. Host A, Jacobsen HP, Halken S, Holmenlund D. The natural history of cow's milk protein allergy/intolerance. *Eur J Clin Nutr* 1995;49 (Suppl. 1):S13–18.
104. Strobel S. Epidemiology of food sensitivity in childhood – with special reference to cow's milk allergy in infancy. *Monogr Allergy* 1993;31:119–30.
105. Klemola T, Vanto T, Juntunen-Backman K, Kalimo K, Korpela R, Varjonen E. Allergy to soy formula and to extensively hydrolyzed whey formula in infants with cow's milk allergy: a prospective, randomized study with a follow-up to the age of 2 years. *J Pediatr* 2002;40:219–24.
106. Shannon WR. Demonstration of food proteins in human breast milk by anaphylactic experiments in guinea pig. *Am J Dis Child* 1921;22:223–5.
107. Mäkinen-Kiljunen S, Palosuo T. A sensitive enzyme-linked immunosorbent assay for determination of bovine beta-lactoglobulin in infant feeding formulas and in human milk. *Allergy* 1992;47:347–52.
108. Axelsson I, Jakobsson I, Lindberg T, Benediktsson B. Bovine beta-lactoglobulin in the human milk. A longitudinal study during the whole lactation period. *Acta Paediatr Scand* 1986;75:702–7.
109. Pittschieler K. Cow's milk protein-induced colitis in the breast-fed infant. *J Pediatr Gastroenterol Nutr* 1990;10:548–9.
110. Vandenplas Y, Hauser B, Van den Borre C, Sacre L, Dab I. Effect of a whey hydrolysate prophylaxis of atopic disease. *Ann Allergy* 1992;68:419–24.
111. Juvonen P, Månsson M, Jakobsson I. Does early diet have an effect on subsequent macromolecular absorption and serum IgE? *J Pediatr Gastroenterol Nutr* 1994;18:344–9.
112. Kaczmarek M, Kurzatowska B. The contribution of some constitutional factors to the development of cow's milk and gluten intolerance in children. *Rocz Akad Med Białymst* 1988;33–34:167–76.
113. Katz AJ, Twarog FJ, Zeiger RS, Falchuk ZM. Milk-sensitive and eosinophilic gastroenteropathy: similar clinical features with contrasting mechanisms and clinical course. *J Allergy Clin Immunol* 1984;74:72–8.
114. Hill SM, Milla PJ. Colitis caused by food allergy in infants. *Arch Dis Child* 1990;65:132–3.
115. Hirano K, Shimojo N, Katsuki T, Ishikawa N, Kohno Y, Niimi H. [Eosinophils in stool smear in normal and milk-allergic infants]. *Arerugi* 1997;46:594–601.
116. Anveden-Hertzberg L, Finkel Y, Sandstedt B, Karpe B. Proctocolitis in exclusively breast-fed infants. *Eur J Pediatr* 1996;155:464–7.
117. Odze RD, Bines J, Leichtner AM, Goldman H, Antonioli DA. Allergic proctocolitis in infants: a prospective clinicopathologic biopsy study. *Hum Pathol* 1993;24:668–74.
118. Machida HM, Catto Smith AG, Gall DG, Trevenen C, Scott RB. Allergic colitis in infancy: clinical and pathologic aspects. *J Pediatr Gastroenterol Nutr* 1994;19:22–6.
119. Alfadda AA, Storr MA, Shaffer EA. Eosinophilic colitis: epidemiology, clinical features, and current management. *Therap Adv Gastroenterol* 2011;4:301–9.
120. Nelson SP, Chen EH, Syniar GM, Christoffel KK. Prevalence of symptoms of gastroesophageal reflux during infancy. A pediatric practice-based survey. *Pediatric Practice Research Group. Arch Pediatr Adolesc Med* 1997;151:569–72.
121. Iacono G, Carroccio A, Cavataio F, Montalto G, Kazmierska I, Lorello D, et al. Gastroesophageal reflux and cow's milk allergy in infants: a prospective study. *J Allergy Clin Immunol* 1996;97:822–7.
122. Cavataio F, Carroccio A, Iacono G. Milk-induced reflux in infants less than one year of age. *J Pediatr Gastroenterol Nutr* 2000;30 (Suppl.):S36–44.
123. Wessel MA, Cobb JC, Jackson EB, Harris GS Jr, Detwiler AC. Paroxysmal fussing in infancy, sometimes called colic. *Pediatrics* 1954;14:421–35.
124. Ruuska T. Occurrence of acute diarrhea in atopic and nonatopic infants: the role of prolonged breast-feeding. *J Pediatr Gastroenterol Nutr* 1992;14:27–33.
125. Caffarelli C, Cavagni G, Deriu FM, Zanotti P, Atherton DJ. Gastrointestinal symptoms in atopic eczema. *Arch Dis Child* 1998;78:230–4.
126. Bengtsson U, Knutson TW, Knutson L, Dannaes A, Hällgren R, Ahlstedt S. Eosinophil cationic protein and histamine after intestinal challenge in patients with cow's milk intolerance. *J Allergy Clin Immunol* 1997;100:216–21.
127. Loening-Baucke V. Constipation in children. *N Engl J Med* 1998;339:1155–6.
128. Clein NW. Cow's milk allergy in infants and children. *Int Arch Allergy Appl Immunol* 1958;13:245–56.
129. Iacono G, Cavataio F, Montalto G, Florena A, Tumminello M, Soresi M, et al. Intolerance of cow's milk and chronic constipation in children. *N Engl J Med* 1998;339:1100–4.
130. Daher S, Tahan S, Solé D, Naspitz CK, Da Silva Patricio FR, Neto UF, et al. Cow's milk protein intolerance and chronic constipation in children. *Pediatr Allergy Immunol* 2001;12:339–42.

# Oral Allergy Syndrome

JULIE WANG

## KEY POINTS

- OAS is an IgE-mediated allergy that is due to cross-reactivity between pollens and homologous food proteins.
- There is significant regional variation in OAS prevalence.
- Several pollen-food associations have been described.
- Although symptoms are generally mild and limited to the oropharyngeal area, systemic reactions can occur.
- Management entails avoiding the foods that trigger symptoms; heated food forms are often well-tolerated when the relevant allergens are heat-labile proteins.

Oral allergy syndrome (OAS) is an IgE-mediated allergy that is due to cross-reacting, homologous proteins between pollens and food proteins.<sup>1</sup> First reported over 70 years ago,<sup>2</sup> OAS involves primarily localized oropharyngeal symptoms in pollen allergic individuals ingesting fresh fruits and vegetables. The increased prevalence of allergic rhinitis and OAS in recent years,<sup>3</sup> along with advances in identification of relevant allergenic proteins, have led to a better understanding of the diverse associations characterizing OAS.

## Epidemiology

Few studies have examined the prevalence of OAS in children; a recent Italian study reported that approximately 25% of children with pollen-induced allergic rhinitis have OAS.<sup>4</sup> Since OAS develops after sensitization to pollens is established, symptoms can develop to food(s) that were previously tolerated. Thus, it is not surprising that the prevalence of OAS in adults is higher, ranging from 30% to 70% among individuals with allergic rhinitis.<sup>5–8</sup> Those who are sensitized to multiple pollens have a higher likelihood of developing clinical allergy to plant-derived foods.<sup>5,9</sup> In addition, data suggest that OAS is more likely in those who have had a longer duration of allergic rhinitis.<sup>4</sup>

Significant regional variations in OAS prevalence have been reported. Differences in pollen exposures as well as differences in relevant proteins contribute to the variations in clinical features. For example, OAS to apple is primarily due to birch pollen sensitization in northern and central Europe, whereas grass pollen sensitization is the main driver of symptoms for OAS to apple in Spain.<sup>10</sup> Regionally distinct allergen sensitization patterns are also reported for kiwi.<sup>11</sup> These geographic differences may be due to regional pollen exposures as well as

differing dietary patterns. In addition, changes in environmental exposures can lead to new sensitizations. For example, two patients who previously tolerated jackfruit while living in the Philippines (a birch-free region) were reported to later develop OAS to jackfruit while in Switzerland, a birch-endemic area.<sup>12</sup>

## Molecular Basis/Pathogenesis

Different phenotypes of IgE-mediated food allergies exist depending on whether the allergy is due to primary or secondary sensitization to food allergens. OAS develops as a result of secondary sensitization, since pollen allergens are the primary sensitizers, and the symptoms elicited by homologous proteins in plant-derived foods are a secondary phenomenon.<sup>13</sup> Conformational epitopes of relevant pollen allergens involved in OAS are generally heat-labile and highly susceptible to gastric digestion, resulting primarily in limited symptoms in the oropharyngeal areas. However, in some cases, systemic reactions or reactions to cooked forms of the foods can occur.

A number of plant proteins that are widely distributed throughout the plant kingdom are mediators of OAS. Pathogenesis-related (PR) proteins are commonly involved. IgE antibodies to the major birch tree pollen (Bet v 1) cross-react with homologous plant food allergens belonging to the PR-10 protein family, often resulting in symptoms to fruits of the order Rosaceae (i.e. apple, pear, cherry and apricot). Other plant-derived foods that contain homologous proteins include peanut, hazelnut and soy, foods that also trigger classic IgE-mediated food allergies.

Profilin is a second category of proteins involved in mediating OAS.<sup>14</sup> The birch tree pollen Bet v 2 is a profilin protein. Although Bet v 2 is reported to be responsible for a broader spectrum of cross-reactivity than Bet v 1,<sup>15</sup> this broad sensitization is not always correlated with clinical reactivity.<sup>16</sup>

Cross-reactive carbohydrate determinants (CCDs) are a group of high molecular weight allergens (45–60 kDa) contained in various pollens and foods<sup>17</sup> that are highly cross-reactive IgE-binding structures.<sup>18</sup> In vitro studies show that 30% to 40% of pollen-allergic individuals have specific IgE against CCDs,<sup>19</sup> but their role in OAS remains less clear.

As more is learned about plant proteins involved in triggering IgE-mediated reactions to foods, a broader term, pollen food allergy syndrome (PFAS), has been coined. Plant-related proteins not only trigger localized symptoms seen in OAS, but also systemic symptoms. Thus, PFAS is used to describe the wide spectrum of symptoms, ranging from localized oropharyngeal to systemic symptoms, that can result from plant-derived foods.

Lipid transfer proteins (LTPs), belonging to the PR-14 family,<sup>20</sup> are major allergens involved in systemic reactions to

plant-related foods that occur in individuals without pollen allergies. Unlike the PR-10 proteins and profilin, LTPs are not susceptible to heat<sup>21</sup> and gastric digestion.<sup>22</sup> LTPs have been identified in a wide variety of foods, including Rosacea fruits as well as other unrelated plant-derived foods (i.e. peanut, corn, asparagus, grape, lettuce, sunflower seeds).<sup>12,23,24</sup>

## Pollen-Food Associations/Syndromes

Several associations and syndromes have been described (Table 46-1).

### BIRCH-FRUIT-VEGETABLE SYNDROME

Many individuals with birch pollen allergy report symptoms when ingesting foods belonging to the order Rosaceae (e.g. apple, pear, peach). The major birch tree pollen allergen, Bet v 1, accounts for most of this cross-reactivity.<sup>25</sup> There is high variability in prevalence of birch-fruit-vegetable syndrome depending on geographic location, with higher rates in birch endemic areas. Birch trees are more common in northern and central Europe and higher rates of OAS to apple are reported in Denmark (34% of birch pollen allergic patients) as compared to Italy (9% of birch pollen allergic patients).<sup>26,27</sup> Although birch trees are not as common outside the northeastern states in the USA, there is a high degree of homology among trees of the Fagales order (e.g. birch, oak, walnut, beech, alder, hazel). Thus, a very high rate of OAS is seen in the USA, with one study reporting that 75.9% of birch pollen allergic patients had clinical symptoms from exposure to apple.<sup>28</sup>

Bet v 1-related proteins have also been identified in peanut,<sup>29</sup> hazelnut<sup>30</sup> and soy.<sup>31</sup> Individuals sensitized to the Bet v 1-homologs in these foods often have no symptoms or localized, transient symptoms with ingestion, despite having detectable IgE levels to these foods. In recent years, there is improved understanding and new technology that allows identification of the relevant allergenic proteins for individuals in order to distinguish between those who have IgE to the major allergens of peanut (Ara h 1, 2, 3) and who are more likely to have systemic reactions, versus those who have elevated IgE to the birch pollen homologous protein (Ara h 8) who have a high chance of tolerance.<sup>32</sup> Similar work has been done for hazelnut<sup>33</sup> and soy.<sup>31,34</sup>

### CELERIAC-MUGWORT-SPICE SYNDROME

Celeriac (also known as turnip-rooted or knob celery) contains Bet v 1 homologs that can trigger OAS in birch endemic areas. However, celeriac allergy has also been reported in birch-free areas; in these cases, mugwort pollen allergens are the primary sensitizers.<sup>14,35</sup> Unlike individuals with celeriac-birch allergy who generally have undetectable IgE levels to celery, those affected by celeriac-mugwort syndrome often have elevated IgE levels to cooked and uncooked celeriac, supporting the finding that different allergens are involved in these two groups.<sup>36</sup> In these individuals who react to cooked celeriac the relevant allergens have been identified to be profilins and cross-reactive carbohydrate determinants.<sup>37,38</sup> Other foods in the Apiaceae family that may trigger similar symptoms include carrot, caraway, parsley, fennel, coriander, fenugreek, cumin, dill and aniseed.<sup>14,39,40</sup>

### RAGWEED-MELON-BANANA ASSOCIATION

Many ragweed allergic patients have detectable IgE to at least one member of the gourd family Cucurbitaceae (e.g. watermelon, cantaloupe, honeydew, zucchini, cucumber).<sup>41</sup> The relevant allergen in these cases is profilin,<sup>14</sup> thus, symptoms are usually limited to the oropharyngeal areas. Banana also has homologous proteins and can trigger similar symptoms in ragweed allergic individuals.<sup>42</sup> Although these symptoms are often mild, reports of systemic reactions to melon range from 11% to 20%,<sup>43,44</sup> suggesting that more stable allergens such as LTPs may be involved at least for some. Moreover, individuals with ragweed-melon-banana association have higher rates of asthma than pollen-allergic individuals without melon allergy, further lending support for a more severe phenotype in these individuals.<sup>43</sup>

### LIPID TRANSFER PROTEIN SYNDROME

Allergies to plant-derived foods can occur in individuals without associated pollen allergies.<sup>45</sup> LTPs act as the primary sensitizer for individuals with allergies to fruits and/or vegetables but no reported symptoms of allergic rhinitis and negative skin tests to pollens,<sup>46,47</sup> particularly in Mediterranean areas.<sup>48-50</sup> Affected individuals have significantly higher rates of systemic reactions (82% vs 45%), including anaphylaxis (73% vs 18%), less frequent oral symptoms (64% vs 91%) and later onset of symptoms to plant-derived foods (19 years of age vs ~12 years) when compared to those who have concurrent pollen allergy. Furthermore, those without pollen allergy have symptoms primarily to the fruits of the order Rosaceae, whereas those with pollen allergy tend to have more diverse sensitizations to different families of fruits, resulting in symptoms to a greater number of foods in general. While the nonpollen allergic group have a higher rate of systemic reactions, the risk of asthma is reported to be higher in those who have concurrent pollen allergy.<sup>14</sup>

The stability of LTPs in the acidic and proteolytic conditions of the gastrointestinal tract as well as their resistance to heating<sup>51</sup> are important factors contributing to the higher rates of systemic reactions reported for this syndrome as compared to the birch-fruit-vegetable syndrome. Data also suggest that LTPs may sensitize via the gastrointestinal route<sup>52</sup> in addition to the respiratory route;<sup>53</sup> thus, LTP may be considered to be a true food allergen.

TABLE 46-1 Pollen-Food Associations

Associations	Examples of Foods That may Trigger Symptoms
Birch-fruit-vegetable syndrome	Apple, pear, peach, almond, hazelnut, peanut, soy
Celeriac-mugwort-spice syndrome	Carrot, caraway, parsley, fennel, coriander, fenugreek, cumin, dill, aniseed
Ragweed-melon-banana association	Banana, cantaloupe, honeydew, watermelon, cucumber, zucchini
Lipid transfer protein (LTP) syndrome	Peach, apple, hazelnut, peanut
Latex-fruit syndrome	Avocado, banana, chestnut, potato, tomato

## LATEX-FRUIT SYNDROME

Significant cross-reactivity between latex and various fruits has been demonstrated, with reports of up to 88% of latex allergic adults having evidence of specific IgE to plant-derived foods.<sup>54,55</sup> While a high degree of immunologic cross-reactivity exists between latex and plant food allergens, the clinical significance appears to be much lower. In a German study of 136 adults with latex allergy, 42.5% reported symptoms with fruit ingestion, but only 32.1% of those reporting symptoms had detectable fruit-specific IgE.<sup>56</sup> In another study that included 57 fruit-allergic individuals, 86% were sensitized to latex, but only 10.5% (6 of 57) had clinically relevant latex allergy.<sup>57</sup>

Primary sensitization to latex occurs via inhalation. Latex-fruit syndrome can manifest with only localized oral symptoms or trigger systemic reactions.<sup>58</sup> The diversity of symptoms is due to the variety of latex allergens that have been identified, including profilins (Hev b 8) as well as more stable allergens such as hevein.<sup>13</sup> A major allergen that belongs to the PR-3 protein family, Hev b 11, retains its IgE-binding epitopes even after the allergen is extensively degraded in simulated gastric fluid.<sup>59</sup>

## Diagnosis

The most important aspect of food allergy diagnosis is the history. Since allergic reactions to plant-derived foods may be due to either primary sensitization from a major food allergen or to a secondary phenomenon with pollens being the primary sensitizer, documentation of the onset and type of symptoms can be very informative for characterizing and managing the allergy. OAS symptoms are generally mild, with localized oropharyngeal symptoms such as lip/mouth itching and swelling that develop acutely with exposure; however, systemic reactions, including anaphylaxis, can occur as well (Table 46-2).<sup>60</sup> Severity of symptoms can have seasonal variations with worsening during the pollen season. In one study of 159 individuals with birch pollen allergy and food-related symptoms, 44% reported worsening of their symptoms during the birch pollen season.<sup>8</sup> This is believed to be a result of up-regulation of birch pollen (Bet v 1 and 2)-specific IgE due to the seasonal pollen exposure.<sup>61</sup>

The utility of skin prick tests (SPTs) and serum specific IgE levels (sIgEs) for the diagnosis of OAS is variable depending on the food allergen in question. In general, SPTs and sIgEs are poor predictors for clinical reactivity to foods. In particular for

OAS, commercial extracts used for SPTs may not contain all the relevant allergens and/or may have low potency for the heat labile allergens as a result of extract processing. Proteases contained in fruits can significantly affect potency as well. For pineapple, bromelain destroys profilin in extracts prepared without protease inhibitors.<sup>62</sup>

Although not technically standardized, using fresh fruits and vegetables for SPTs generally has improved diagnostic utility compared to commercial extracts. In one study of 36 grass and/or birch pollen allergic individuals, SPTs with fresh hazelnut, apple and melon had high sensitivity (89–97%) and specificity (>70%). The negative predictive value was >90%, but the positive predictive value was more variable, ranging from 50% to 85%.<sup>63</sup> Since it is not always possible to have fresh fruits and vegetables available for SPTs, use of frozen fruits is an acceptable alternative as freezing does not alter the antigenic properties of fresh fruits.<sup>64</sup>

Several other factors can significantly affect the sensitivity of fresh food SPTs. Allergenicity increases with ripening in several foods, including banana<sup>65</sup> and peach.<sup>66</sup> Time of storage and storage conditions can further influence allergenicity. The apple allergen, Mal d 1, has been shown to increase significantly with storage.<sup>67</sup> Differing levels of allergen are also noted among different cultivars. For example, high variations in Mal d 1 and LTP content are found across different apple cultivars.<sup>68,69</sup>

Measurement of sIgE may also be used to support the diagnosis of OAS. In a study of patients with a clinical history of OAS to melons, the positive predictive value was comparable for sIgE (ImmunoCAP®; Thermo Fisher Scientific, Waltham, MA, USA) and fresh food SPT (44% for sIgE vs 42% for SPT), and a slightly higher negative predictive value was observed for fresh food SPT (77% SPT vs 70% sIgE).<sup>44</sup> Similar to SPTs, the utility of sIgE measurement varies for different food allergens.

With advances in the identification and characterization of relevant allergens, recombinant proteins for the detection of sIgE are increasingly being used for food allergy diagnostic purposes. While component resolved diagnosis (CRD) has been shown to be useful to distinguish between phenotypes of allergy for some foods such as peanut and hazelnut,<sup>32,33</sup> the utility of CRD for other plant-derived food allergies is variable. In one study of individuals with birch pollen allergies, CRD was not shown to have added diagnostic utility in predicting clinical reactivity to raw fruits and vegetables.<sup>70</sup> Another group reported improved sensitivity of CRD with individual celeriac allergens compared with extract-based ImmunoCAP diagnosis (88% for CRD vs 67% for extract).<sup>71</sup> However, sIgE levels to individual allergens or extract did not predict severity of reactions to celeriac. Similarly, while some studies note the value of measuring sIgE to individual peach proteins for characterization of peach reactions,<sup>72,73</sup> these levels were not predictive of systemic symptoms.<sup>74</sup> Further studies are needed to determine the role of CRD in the diagnosis of OAS.

Since SPT and sIgE results do not always correlate with clinical reactivity, double-blind, placebo-controlled food challenge remains the gold standard for food allergy diagnosis. While standardized protocols are established for challenges to food allergens that are the primary sensitizer, there are currently no standardized protocols for diagnosing OAS. Adequate blinding of fresh foods is also a challenge. In many cases, a convincing history is sufficient to diagnose OAS; Anhoj et al reported high sensitivity and specificity of case histories in predicting challenge outcome for apple and melon.<sup>63</sup>

TABLE  
46-2

### Clinical Manifestations of Oral Allergy Syndrome (OAS)/Pollen Food Allergy Syndrome (PFAS)

Localized, oropharyngeal symptoms:
Lip/mouth swelling
Lip/mouth/throat itching
Laryngeal edema
Systemic symptoms:
Cutaneous – urticaria, angioedema
Ocular – conjunctivitis
Upper respiratory tract – rhinorrhea, congestion
Lower respiratory tract – wheezing
Gastrointestinal – abdominal pain, cramps, nausea, vomiting, diarrhea
Anaphylaxis



## Management

Since consensus guidelines for the management of OAS do not exist, management of OAS is highly variable among practicing physicians.<sup>75</sup> In a survey of US allergists, responses ranged from advising avoidance of only the offending fruits or vegetables to recommending elimination of entire botanical families of foods. It is important to note that clinical reactivity to one member of a botanical family does not guarantee that symptoms will occur to all foods in a botanical family. In one study of 23 individuals with OAS to peach, 63% reported symptoms to more than one Prunoideae fruit,<sup>76</sup> and another study of 26 individuals with fruit allergy reported that 46% had reactions to more than one Rosaceae fruit.<sup>77</sup> Thus, elimination of entire botanical families is not necessary and will be overly restrictive for many affected individuals.

As previously stated, allergenicity can vary between different cultivars of fruits.<sup>68,69</sup> Therefore, choosing lower allergenic cultivars may reduce symptoms for some. In addition, the distribution of allergen is not uniform throughout the fruit. Much higher concentrations of LTP are found in the skin of apples and peaches compared to the pulp.<sup>78</sup> In one small study, over 40% of individuals with allergies to apple and pear were able to tolerate the flesh, but had symptoms upon ingestion of the whole fruit.<sup>79</sup>

When heat-labile proteins are the main elicitor of symptoms, heating or cooking the fruits and vegetables denatures the relevant proteins, which allows affected individuals to ingest the foods without incurring symptoms. For foods that are more typically eaten in the uncooked form (e.g. apples), brief heating in the microwave can sufficiently denature the Bet v 1-homolog while maintaining the integrity of the fruit. A recent study showed that continuous consumption may be of benefit for OAS triggered by apple; frequent consumption was associated with reductions in OAS symptoms.<sup>80</sup> This has not been explored in controlled trials or reported for other foods.

Since plant-derived foods can also trigger systemic reactions, prescription of self-injectable epinephrine and education on the management of severe reactions is advisable. A study of Spanish children with peach allergy found that 28% reported having severe reactions that required treatment with epinephrine.<sup>81</sup> Factors identified to increase an individual's risk for systemic reactions include prior history of a systemic reaction to the food, reaction to cooked forms of the food,<sup>20,37</sup> positive SPT to the commercial food extract,<sup>82</sup> lack of pollen sensitization<sup>45</sup> and sensitization to LTP.<sup>83</sup> Additionally, concurrent atopic conditions and medications are important details to consider. For example, individuals taking daily antihistamines for allergic rhinitis may not notice early, mild OAS symptoms, leading to increased consumption of the triggering foods and thus increasing the risk of systemic symptoms.<sup>84</sup>

## IMMUNOTHERAPY

Immunotherapy has been explored for the treatment of OAS as it has proven to be an effective treatment for allergic rhinitis.

Several small studies have demonstrated reductions in oral symptoms in over half of subjects receiving immunotherapy to pollens for the treatment of OAS; however, these studies were limited by the lack of objective outcome measures and/or placebo controls.<sup>85-88</sup> Other studies have shown no significant benefit of immunotherapy (subcutaneous, oral or sublingual) for OAS.<sup>88-90</sup> Immunotherapy using specific food allergens has also been explored, but relapse of symptoms occurs quickly after discontinuation immunotherapy.<sup>80</sup> Moreover, a case report of OAS developing after a patient started on birch pollen sublingual therapy has been published.<sup>91</sup> Therefore, immunotherapy remains an unproven approach for treating OAS.

## Conclusions

Oral allergy syndrome (pollen food allergy syndrome) is a common food allergy that occurs as a result of cross-reactivities between plant pollens and proteins in plant-derived foods. As more understanding of relevant allergens is gained, advances in diagnosis and management may be possible.

### KEY CONCEPTS FOR OAS

#### CHARACTERISTICS

- Patients sensitized to multiple pollens or who have had a longer duration of allergic rhinitis are at higher risk for OAS.
- OAS symptoms are generally mild, with localized oropharyngeal symptoms such as lip/mouth itching and swelling.
- Systemic reactions can occur as well; anaphylaxis can occur in 2% of cases.
- Seasonal variations for OAS have been observed, with some reporting worsening of symptoms during the pollen season.

#### DIAGNOSIS

- History is the most important aspect of OAS diagnosis.
- While SPT and measurement of sIgE levels can identify the pollens that are triggering allergic rhinitis, SPT and sIgE are less reliable for identifying the triggering foods for OAS.
- SPT with fresh fruits and vegetables correlate better with clinical symptoms when compared to commercial extracts; however, this is not standardized.
- Double-blind, placebo-controlled food challenge remains the gold standard for food allergy diagnosis.

#### MANAGEMENT

- Symptoms elicited by one food do not necessarily predict symptoms elicited by all members within a botanical family; thus, patients are advised to avoid only the fruits and/or vegetables that trigger symptoms.
- When heat-labile proteins are the main elicitor of symptoms, heating the food allergens denatures the relevant protein(s), allowing symptom-free consumption.
- Since OAS can lead to systemic reactions and anaphylaxis in some cases, it is important for patients to be knowledgeable about the identification and treatment of systemic reactions, including indications for self-injectable epinephrine.

The complete reference list can be found on the companion Expert Consult website at <http://www.expertconsult.inkling.com>.



## KEY REFERENCES

4. Dondi A, Tripodi S, Panetta V, Asero R, Businco AD, Bianchi A, et al. Pollen-induced allergic rhinitis in 1360 Italian children: comorbidities and determinants of severity. *Pediatr Allergy Immunol* 2013;24:742–51.
22. Asero R, Mistrello G, Roncarolo D, de Vries SC, Gautier MF, Ciurana CL, et al. Lipid transfer protein: a pan-allergen in plant-derived foods that is highly resistant to pepsin digestion. *Int Arch Allergy Immunol* 2001;124:67–9.
27. Osterballe M, Hansen TK, Mortz CG, Bindslev-Jensen C. The clinical relevance of sensitization to pollen-related fruits and vegetables in unselected pollen-sensitized adults. *Allergy* 2005;60:218–25.
32. Nicolaou N, Poorafshar M, Murray C, Simpson A, Winell H, Kerry G, et al. Allergy or tolerance in children sensitized to peanut: prevalence and differentiation using component-resolved diagnostics. *J Allergy Clin Immunol* 2010;125:191–7. e1–13.
44. Rodriguez J, Crespo JF, Burks W, Rivas-Plata C, Fernandez-Anaya S, Vives R, et al. Randomized, double-blind, crossover challenge study in 53 subjects reporting adverse reactions to melon (*cucumis melo*). *J Allergy Clin Immunol* 2000;106:968–72.
56. Brehler R, Theissen U, Mohr C, Luger T. ‘Latex-fruit syndrome’: frequency of cross-reacting IgE antibodies. *Allergy* 1997;52:404–10.
60. Kleine-Tebbe J, Vogel L, Crowell DN, Hausteiner UF, Vieths S. Severe oral allergy syndrome and anaphylactic reactions caused by a Bet v 1-related PR-10 protein in soybean, SAM22. *J Allergy Clin Immunol* 2002;110:797–804.
67. Matthes A, Schmitz-Eiberger M. Apple (*Malus domestica* L. Borkh.) allergen Mal d 1: effect of cultivar, cultivation system, and storage conditions. *J Agric Food Chem* 2009;57:10548–53.
77. Rodriguez J, Crespo JF, Lopez-Rubio A, De La Cruz-Bertolo J, Ferrando-Vivas P, Vives R, et al. Clinical cross-reactivity among foods of the Rosaceae family. *J Allergy Clin Immunol* 2000;106:183–9.
82. Asero R. Detection and clinical characterization of patients with oral allergy syndrome caused by stable allergens in rosaceae and nuts. *Ann Allergy Asthma Immunol* 1999;83:377–83.

## REFERENCES

- Amlot PL, Kemeny DM, Zachary C, Parkes P, Lessof MH. Oral allergy syndrome (OAS): symptoms of IgE-mediated hypersensitivity to foods. *Clin Allergy* 1987;17:33–42.
- Tuft L, Blumstein GI. Studies in food allergy. II. Sensitization in fresh fruits: clinical and experimental observations. *J Allergy* 1942;13:574–81.
- De Knop KJ, Verweij MM, Grimmlikhuijsen M, Philipse E, Hagendorens MM, Bridts CH, et al. Age-related sensitization profiles for hazelnut (*Corylus avellana*) in a birch-endemic region. *Pediatr Allergy Immunol* 2011;22:e139–49.
- Dondi A, Tripodi S, Panetta V, Asero R, Businco AD, Bianchi A, et al. Pollen-induced allergic rhinitis in 1360 Italian children: comorbidities and determinants of severity. *Pediatr Allergy Immunol* 2013;24:742–51.
- Osterballe M, Hansen TK, Mortz CG, Bindslev-Jensen C. The clinical relevance of sensitization to pollen-related fruits and vegetables in unselected pollen-sensitized adults. *Allergy* 2005;60:218–25.
- Bircher AJ, Van Melle G, Haller E, Curty B, Frei PC. IgE to food allergens are highly prevalent in patients allergic to pollens, with and without symptoms of food allergy. *Clin Exp Allergy* 1994;24:367–74.
- Eriksson NE, Formgren H, Svenonius E. Food hypersensitivity in patients with pollen allergy. *Allergy* 1982;37:437–43.
- Geroldinger-Simic M, Zelniker T, Aberer W, Ebner C, Egger C, Greiderer A, et al. Birch pollen-related food allergy: clinical aspects and the role of allergen-specific IgE and IgG<sub>4</sub> antibodies. *J Allergy Clin Immunol* 2011;127:616–22.
- Ricci G, Righetti F, Menna G, Bellini F, Miniaci A, Masi M. Relationship between bet v 1 and bet v 2 specific IgE and food allergy in children with grass pollen respiratory allergy. *Mol Immunol* 2005;42:1251–7.
- Pastorello EA, Ortolani C. Oral allergy syndrome. In: Metcalfe DD, Sampson HA, Simon RA, editors. *Food allergy*. 3rd ed. Massachusetts: Blackwell Publishing; 2003. p. 169–82.
- Bublin M, Mari A, Ebner C, Knulst A, Scheiner O, Hoffmann-Sommergruber K, et al. IgE sensitization profiles toward green and gold kiwifruits differ among patients allergic to kiwifruit from 3 European countries. *J Allergy Clin Immunol* 2004;114:1169–75.
- van Ree R. Clinical importance of cross-reactivity in food allergy. *Curr Opin Allergy Clin Immunol* 2004;4:235–40.
- Yagami T, Haishima Y, Nakamura A, Osuna H, Ikezawa Z. Digestibility of allergens extracted from natural rubber latex and vegetable foods. *J Allergy Clin Immunol* 2000;106:752–62.
- Egger M, Mutschlechner S, Wopfner N, Gademajer G, Briza P, Ferreira F. Pollen-food syndromes associated with weed pollinosis: an update from the molecular point of view. *Allergy* 2006;61:461–76.
- Wensing M, Akkerdaas JH, van Leeuwen WA, Stapel SO, Bruijnzeel-Koomen CA, Aalberse RC, et al. IgE to bet v 1 and profilin: cross-reactivity patterns and clinical relevance. *J Allergy Clin Immunol* 2002;110:435–42.
- Pauli G, Oster JP, Deviller P, Heiss S, Bessot JC, Susani M, et al. Skin testing with recombinant allergens rBet v 1 and birch profilin, rBet v 2: diagnostic value for birch pollen and associated allergies. *J Allergy Clin Immunol* 1996;97:1100–9.
- Ebo DG, Hagendorens MM, Bridts CH, De Clerck LS, Stevens WJ. Sensitization to cross-reactive carbohydrate determinants and the ubiquitous protein profilin: mimickers of allergy. *Clin Exp Allergy* 2004;34:137–44.
- Pastorello EA, Farioli L, Pravettoni V, Giuffrida MG, Ortolani C, Fortunato D, et al. Characterization of the major allergen of plum as a lipid transfer protein. *J Chromatogr B Biomed Sci Appl* 2001;756:95–103.
- Mari A. Multiple pollen sensitization: a molecular approach to the diagnosis. *Int Arch Allergy Immunol* 2001;125:57–65.
- Pastorello EA, Pompei C, Pravettoni V, Farioli L, Calamari AM, Scibilia J, et al. Lipid-transfer protein is the major maize allergen maintaining IgE-binding activity after cooking at 100 degrees C, as demonstrated in anaphylactic patients and patients with positive double-blind, placebo-controlled food challenge results. *J Allergy Clin Immunol* 2003;112:775–83.
- Sancho AI, Rigby NM, Zuidmeer L, Asero R, Mistrello G, Amato S, et al. The effect of thermal processing on the IgE reactivity of the non-specific lipid transfer protein from apple, Mal d 3. *Allergy* 2005;60:1262–8.
- Asero R, Mistrello G, Roncarolo D, de Vries SC, Gautier MF, Ciurana CL, et al. Lipid transfer protein: a pan-allergen in plant-derived foods that is highly resistant to pepsin digestion. *Int Arch Allergy Immunol* 2001;124:67–9.
- Krause S, Reese G, Randow S, Zennaro D, Quarantino D, Palazzo P, et al. Lipid transfer protein (Ara h 9) as a new peanut allergen relevant for a Mediterranean allergic population. *J Allergy Clin Immunol* 2009;124:771–8.
- Pastorello EA, Farioli L, Pravettoni V, Ispano M, Scibola E, Trambaioli C, et al. The maize major allergen, which is responsible for food-induced allergic reactions, is a lipid transfer protein. *J Allergy Clin Immunol* 2000;106:744–51.
- Breiteneder H, Pettenburger K, Bito A, Valenta R, Kraft D, Rumpold H, et al. The gene coding for the major birch pollen allergen Betv1, is highly homologous to a pea disease resistance response gene. *EMBO J* 1989;8:1935–8.
- Hannuksela M, Lahti A. Immediate reactions to fruits and vegetables. *Contact Dermatitis* 1977;3:79–84.
- Osterballe M, Hansen TK, Mortz CG, Bindslev-Jensen C. The clinical relevance of sensitization to pollen-related fruits and vegetables in unselected pollen-sensitized adults. *Allergy* 2005;60:218–25.
- Ebner C, Birkner T, Valenta R, Rumpold H, Breitenbach M, Scheiner O, et al. Common epitopes of birch pollen and apples—studies by western and northern blot. *J Allergy Clin Immunol* 1991;88:588–94.
- Mittag D, Akkerdaas J, Ballmer-Weber BK, Vogel L, Wensing M, Becker WM, et al. Ara h 8, a bet v 1-homologous allergen from peanut, is a major allergen in patients with combined birch pollen and peanut allergy. *J Allergy Clin Immunol* 2004;114:1410–17.
- Pastorello EA, Vieths S, Pravettoni V, Farioli L, Trambaioli C, Fortunato D, et al. Identification of hazelnut major allergens in sensitive patients with positive double-blind, placebo-controlled food challenge results. *J Allergy Clin Immunol* 2002;109:563–70.
- Mittag D, Vieths S, Vogel L, Becker WM, Rihs HP, Helbling A, et al. Soybean allergy in patients allergic to birch pollen: clinical investigation and molecular characterization of allergens. *J Allergy Clin Immunol* 2004;113:148–54.
- Nicolaou N, Poorafshar M, Murray C, Simpson A, Winell H, Kerry G, et al. Allergy or tolerance in children sensitized to peanut: prevalence and differentiation using component-resolved diagnostics. *J Allergy Clin Immunol* 2010;125:191–7. e1–13.
- Masthoff LJ, Mattsson L, Zuidmeer-Jongejan L, Lidholm J, Andersson K, Akkerdaas JH, et al. Sensitization to Cor a 9 and Cor a 14 is highly specific for a hazelnut allergy with objective symptoms in Dutch children and adults. *J Allergy Clin Immunol* 2013;132:393–9.
- Ito K, Sjölander S, Sato S, Movérare R, Tanaka A, Söderström L, et al. IgE to Gly m 5 and Gly m 6 is associated with severe allergic reactions to soybean in Japanese children. *J Allergy Clin Immunol* 2011;128:673–5.
- Hoffmann-Sommergruber K, Demoly P, Cramer R, Breiteneder H, Ebner C, Laimer Da Camara Machado M, et al. IgE reactivity to Api g 1, a major celery allergen, in a central European population is based on primary sensitization by Bet v 1. *J Allergy Clin Immunol* 1999;104:478–84.
- Wüthrich B, Stager J, Johansson SG. Celery allergy associated with birch and mugwort pollinosis. *Allergy* 1990;45:566–71.
- Ballmer-Weber BK, Hoffmann A, Wüthrich B, Lüttkopf D, Pompei C, Wangorsch A, et al. Influence of food processing on the allergenicity of celery: DBPCFC with celery spice and cooked celery in patients with celery allergy. *Allergy* 2002;57:228–35.
- Bublin M, Radauer C, Wilson IB, Kraft D, Scheiner O, Breiteneder H, et al. Cross-reactive N-glycans of Api g 5, a high molecular weight glycoprotein allergen from celery, are required for immunoglobulin E binding and activation of effector cells from allergic patients. *FASEB J* 2003;17:1697–9.
- Wüthrich B, Stäger J, Johansson SG. Celery allergy associated with birch and mugwort pollinosis. *Allergy* 1990;45:566–71.
- Yagami A, Nakazawa Y, Suzuki K, Matsunaga K. Curry spice allergy associated with pollen-food allergy syndrome and latex fruit-syndrome. *J Dermatol* 2009;36:45–9.
- Enberg RN, Leickly FE, McCullough J, Bailey J, Ownby DR. Watermelon and ragweed share allergens. *J Allergy Clin Immunol* 1987;79:867–75.
- Grob M, Reindl J, Vieths S, Wüthrich B, Ballmer-Weber BK. Heterogeneity of banana allergy: characterization of allergens in banana-allergic patients. *Ann Allergy Asthma Immunol* 2002;89:513–16.
- Figueredo E, Cuesta-Herranz J, De-Miguel J, Lázaro M, Sastre J, Quirce S, et al. Clinical characteristics of melon (*Cucumis melo*) allergy. *Ann Allergy Asthma Immunol* 2003;91:303–8.
- Rodríguez J, Crespo JF, Burks W, Rivas-Plata C, Fernandez-Anaya S, Vives R, et al. Randomized, double-blind, crossover challenge study in 53 subjects reporting adverse reactions to melon (*cucumis melo*). *J Allergy Clin Immunol* 2000;106:968–72.
- Fernandez-Rivas M, van Ree R, Cuevas M. Allergy to rosaceae fruits without related

- pollinosis. *J Allergy Clin Immunol* 1997;100:728–33.
46. Ortolani C, Spano M, Pastorello E, Bigi A, Ansaloni R. The oral allergy syndrome. *Ann Allergy* 1988;61:47–52.
  47. Hernández J, García Sellés FJ, Pagán JA, Negro JM. Immediate hypersensitivity to fruits and vegetables and pollenosis. *Allergol Immunopathol* 1985;13:197–211.
  48. Fernández-Rivas M, González-Mancebo E, Rodríguez-Pérez R, Benito C, Sánchez-Monge R, Salcedo G, et al. Clinically relevant peach allergy is related to peach lipid transfer protein, Pru p 3, in the Spanish population. *J Allergy Clin Immunol* 2003;112:789–95.
  49. Ballmer-Weber BK. Lipid transfer protein as a potential panallergen? *Allergy* 2002;57:873–5.
  50. Scheurer S, Pastorello EA, Wangorsch A, Kästner M, Hausteiner D, Vieths S. Recombinant allergens Pru av 1 and Pru av 4 and a newly identified lipid transfer protein in the in vitro diagnosis of cherry allergy. *J Allergy Clin Immunol* 2001;107:724–31.
  51. Scheurer S, Lauer I, Foetisch K, San Miguel Moncin M, Retzek M, Hartz C, et al. Strong allergenicity of Pru av 3, the lipid transfer protein from cherry, is related to high stability against thermal processing and digestion. *J Allergy Clin Immunol* 2004;114:900–7.
  52. Schulten V, Radakovics A, Hartz C, Mari A, Vazquez-Cortes S, Fernandez-Rivas M, et al. Characterization of the allergic T-cell response to Pru p 3, the nonspecific lipid transfer protein in peach. *J Allergy Clin Immunol* 2009;124:100–7.
  53. Borghesan F, Mistrello G, Roncarolo D, Amato S, Plebani M, Asero R. Respiratory allergy to lipid transfer protein. *Int Arch Allergy Immunol* 2008;147:161–5.
  54. Beezhold DH, Sussman GL, Liss GM, Chang NS. Latex allergy can induce clinical reactions to specific foods. *Clin Exp Allergy* 1996;26:416–22.
  55. Ebo DG, Bridts CH, Hagendorens MM, De Clerck LS, Stevens WJ. The prevalence and diagnostic value of specific IgE antibodies to inhalant, animal and plant food, and ficus allergens in patients with natural rubber latex allergy. *Acta Clin Belg* 2003;58:183–9.
  56. Brehler R, Theissen U, Mohr C, Luger T. 'Latex-fruit syndrome': frequency of cross-reacting IgE antibodies. *Allergy* 1997;52:404–10.
  57. García Ortiz JC, Moyano JC, Alvarez M, Bellido J. Latex allergy in fruit-allergic patients. *Allergy* 1998;53:532–6.
  58. Yagami T. Allergies to cross-reactive plant proteins. latex-fruit syndrome is comparable with pollen-food allergy syndrome. *Int Arch Allergy Immunol* 2002;128:271–9.
  59. Diaz-Perales A, Blanco C, Sanchez-Monge R, Varela J, Carrillo T, Salcedo G. Analysis of avocado allergen (Prs a 1) IgE-binding peptides generated by simulated gastric fluid digestion. *J Allergy Clin Immunol* 2003;112:1002–7.
  60. Kleine-Tebbe J, Vogel L, Crowell DN, Hausteiner UF, Vieths S. Severe oral allergy syndrome and anaphylactic reactions caused by a Bet v 1-related PR-10 protein in soybean, SAM22. *J Allergy Clin Immunol* 2002;110:797–804.
  61. Magnusson J, Lin XP, Dahlman-Högglund A, Hanson LLA, Telemo E, Magnusson O, et al. Seasonal intestinal inflammation in patients with birch pollen allergy. *J Allergy Clin Immunol* 2003;112:45–50.
  62. Reindl J, Rihs HP, Scheurer S, Wangorsch A, Hausteiner D, Vieths S. IgE reactivity to profilin in pollen-sensitized subjects with adverse reactions to banana and pineapple. *Int Arch Allergy Immunol* 2002;128:105–14.
  63. Anhoj C, Backer V, Nolte H. Diagnostic evaluation of grass- and birch-allergic patients with oral allergy syndrome. *Allergy* 2001;56:548–52.
  64. Begin P, Des Roches A, Nguyen M, Masse MS, Paradis J, Paradis L. Freezing does not alter antigenic properties of fresh fruits for skin testing in patients with birch tree pollen-induced oral allergy syndrome. *J Allergy Clin Immunol* 2011;127:1624–6.
  65. Clendennen SK, May GD. Differential gene expression in ripening banana fruit. *Plant Physiol* 1997;115:463–9.
  66. Brenna OV, Pastorello EA, Farioli L, Pravettoni V, Pompei C. Presence of allergenic proteins in different peach (*Prunus persica*) cultivars and dependence of their content on fruit ripening. *J Agric Food Chem* 2004;52:7997–8000.
  67. Matthes A, Schmitz-Eiberger M. Apple (*Malus domestica* L. Borkh.) allergen Mal d 1: effect of cultivar, cultivation system, and storage conditions. *J Agric Food Chem* 2009;57:10548–53.
  68. Carnes J, Ferrer A, Fernandez-Caldas E. Allergenicity of 10 different apple varieties. *Ann Allergy Asthma Immunol* 2006;96:564–70.
  69. Sancho AI, van Ree R, van Leeuwen A, Meulenbroek BJ, van de Weg EW, Gilissen LJ, et al. Measurement of lipid transfer protein in 88 apple cultivars. *Int Arch Allergy Immunol* 2008;146:19–26.
  70. Tolkki L, Alanko K, Petman L, Blem Skydtsgaard M, Gronager Milvang P, Seppälä U, et al. Clinical characterization and IgE profiling of Birch (*Betula verrucosa*)-allergic individuals suffering from allergic reactions to raw fruits and vegetables. *J Allergy Clin Immunol Pract* 2013;1:623–31. e1.
  71. Bauermeister K, Ballmer-Weber BK, Bublin M, Fritsche P, Hanschmann KM, Hoffmann-Sommergruber K, et al. Assessment of component-resolved in vitro diagnosis of celiac allergy. *J Allergy Clin Immunol* 2009;124:1273–81. e2.
  72. Rossi RE, Monasterolo G, Canonica GW, Pasalacqua G. Systemic reactions to peach are associated with high levels of specific IgE to Pru p 3. *Allergy* 2009;64:1795–6.
  73. Gaier S, Oberhuber C, Hemmer W, Radauer C, Rigby NM, Marsh JT, et al. Pru p 3 as a marker for symptom severity for patients with peach allergy in a birch pollen environment. *J Allergy Clin Immunol* 2009;124:166–7.
  74. Novembre E, Mori F, Contestabile S, Rossi ME, Pucci N. Correlation of anti-Pru p 3 IgE levels with severity of peach allergy reactions in children. *Ann Allergy Asthma Immunol* 2012;108:271–4.
  75. Ma S, Sicherer SH, Nowak-Wegrzyn A. A survey on the management of pollen-food allergy syndrome in allergy practices. *J Allergy Clin Immunol* 2003;112:784–8.
  76. Pastorello EA, Ortolani C, Farioli L, Pravettoni V, Spano M, Borga A, et al. Allergenic cross-reactivity among peach, apricot, plum, and cherry in patients with oral allergy syndrome: an in vivo and in vitro study. *J Allergy Clin Immunol* 1994;94:699–707.
  77. Rodriguez J, Crespo JF, Lopez-Rubio A, De La Cruz-Bertolo J, Ferrando-Vivas P, Vives R, et al. Clinical cross-reactivity among foods of the Rosaceae family. *J Allergy Clin Immunol* 2000;106:183–9.
  78. Borges JP, Jauneau A, Brulé C, Culerrier R, Barre A, Didier A, et al. The lipid transfer proteins (LTP) essentially concentrate in the skin of Rosaceae fruits as cell surface exposed allergens. *Plant Physiol Biochem* 2006;44:535–42.
  79. Fernández-Rivas M, Cuevas M. Peels of Rosaceae fruits have a higher allergenicity than pulps. *Clin Exp Allergy* 1999;29:1239–47.
  80. Kopac P, Rudin M, Gentinetta T, Gerber R, Pichler Ch, Hausmann O, et al. Continuous apple consumption induces oral tolerance in birch-pollen-associated apple allergy. *Allergy* 2012;67:280–5.
  81. Boyano-Martínez T, Pedrosa M, Belver T, Quirce S, García-Ara C. Peach allergy in Spanish children: tolerance to the pulp and molecular sensitization profile. *Pediatr Allergy Immunol* 2013;24:168–72.
  82. Asero R. Detection and clinical characterization of patients with oral allergy syndrome caused by stable allergens in rosaceae and nuts. *Ann Allergy Asthma Immunol* 1999;83:377–83.
  83. Pastorello EA, Farioli L, Pravettoni V, Ortolani C, Spano M, Monza M, et al. The major allergen of peach (*Prunus persica*) is a lipid transfer protein. *J Allergy Clin Immunol* 1999;103:520–6.
  84. Mari A, Ballmer-Weber BK, Vieths S. The oral allergy syndrome: improved diagnostic and treatment methods. *Curr Opin Allergy Clin Immunol* 2005;5:267–73.
  85. Asero R. Effects of birch pollen-specific immunotherapy on apple allergy in birch pollen-hypersensitive patients. *Clin Exp Allergy* 1998;28:1368–73.
  86. Bolhaar ST, Tiemessen MM, Zuidmeer L, van Leeuwen A, Hoffmann-Sommergruber K, Brujnzeel-Koomen CA, et al. Efficacy of birch-pollen immunotherapy on cross-reactive food allergy confirmed by skin tests and double-blind food challenges. *Clin Exp Allergy* 2004;34:761–9.
  87. Alonso R, Enrique E, Pineda F, Basagaña M, San Miguel-Moncin MM, Bartra J, et al. An observational study on outgrowing food allergy during non-birch pollen-specific, subcutaneous immunotherapy. *Int Arch Allergy Immunol* 2007;143:185–9.
  88. Mauro M, Russello M, Incorvaia C, Gazzola G, Frati F, Moingeon P, et al. Birch-apple syndrome treated with birch pollen immunotherapy. *Int Arch Allergy Immunol* 2011;156:416–22.
  89. Moller C. Effect of pollen immunotherapy on food hypersensitivity in children with birch pollenosis. *Ann Allergy* 1989;62:343–5.
  90. Kinaciyan T, Jahn-Schmid B, Radakovics A, Zwölfer B, Schreiber C, Francis JN, et al. Successful sublingual immunotherapy with birch pollen has limited effects on concomitant food allergy to apple and the immune response to the Bet v 1 homolog Mal d 1. *J Allergy Clin Immunol* 2007;119:937–43.
  91. Ciprandi G. Onset of oral allergic syndrome during birch sublingual immunotherapy. *Eur Ann Allergy Clin Immunol* 2012;44:170–1.



# Atopic Dermatitis and Food Hypersensitivity

JULIE WANG | HUGH A. SAMPSON

## KEY POINTS

- About one third of children with moderate to severe atopic dermatitis (AD) are affected by food hypersensitivity.
- A food allergy evaluation should be considered in children with moderate to severe AD.
- Egg allergy is the most common food hypersensitivity in children with AD; milk, eggs and peanuts generally cause more than 75% of the IgE-mediated reactions.
- Appropriate diagnosis of food allergy and elimination of the responsible food allergen lead to significant clearing of eczematous lesions in the majority of children with AD and food hypersensitivity.
- Infants with AD and egg allergy are at high risk for developing respiratory allergy and asthma.

## Introduction

Atopic dermatitis (AD) is a complex, chronic disorder that has been referred to as ‘the itch that rashes’. The origin of AD is multifactorial, including many commonly encountered triggers. In 1892 Besnier<sup>1</sup> used the term ‘neurodermatitis’ to describe a chronic, pruritic skin condition seen in patients with a nervous disorder. In the early 1900s, Coca and Cooke<sup>2</sup> noted the occurrence of a similar disorder with asthma and hay fever, and used the term ‘atopy’ to refer to the constellation of these allergic diseases. The term ‘atopic dermatitis’ was then coined by Wise and Sulzberger<sup>3</sup> in 1933 to comprehensively describe this inheritable skin disorder. Since its earliest description, AD has had one primary feature: intense pruritus triggered by a variety of stimuli. In this chapter, we review how the ingestion of specific foods can trigger the condition of AD.

A strong correlation exists between AD and other atopic conditions, and AD is often the first manifestation of the ‘atopic march’. Approximately 50% of patients with AD develop it in the first year of life, and as many as 50% to 80% of children with AD will develop allergic respiratory disease later in life.<sup>4</sup> Because of these early historical observations, investigators have explored the role of various allergens as triggers for the pathogenesis of AD (Box 47-1).

Food allergy has been strongly correlated with the development and persistence of AD, especially during infancy and early childhood. The skin is the site that is most often involved in food hypersensitivity reactions. For most skin manifestations of food hypersensitivity, pruritus is a hallmark of the disease. As depicted in Figure 47-1, the earlier the onset and the more

severe the AD, the more likely it is that the child will develop food allergies.<sup>5</sup>

## Pathophysiology

In the early 20th century, Schloss,<sup>6</sup> Talbot<sup>7</sup> and Blackfan<sup>8</sup> published case reports of patients who had improvement in their AD after removing specific foods from their diets. Subsequent conflicting reports spurred controversy related to the role of specific food allergens in the pathogenesis of AD.<sup>9</sup> This controversy has continued into the 21st century, although there is now significant laboratory and clinical evidence that would suggest the debate is no longer valid. Factors important in the pathophysiology of AD include barrier function, innate and adaptive immune responses and genetics, all of which have some relationship to allergen exposure.<sup>10,11</sup> Studies have demonstrated that allergen-induced, IgE-mediated mast cell activation has, as its end product, hypersensitivity reactions characterized by tissue (i.e. skin) infiltration of eosinophils, monocytes and lymphocytes.<sup>10–12</sup> The pattern of cytokine and chemokine expression found in lymphocytes infiltrating acute AD lesions is predominantly that of the T helper cell type 2 (Th2) (interleukin [IL]-4, IL-5, and IL-13).<sup>13,14</sup> In addition, these cytokines promote influx of activated eosinophils and release of eosinophil products.<sup>13–16</sup> Epidermal, myeloid-derived dendritic cells express high-affinity IgE receptors (FcεRI) that bind IgE and are noted in biopsy tissue from inflamed AD skin. These cells take up and present allergens to Th1, Th2 and T regulatory cells, all of which are important in AD.<sup>10</sup> In addition, IgE-bearing Langerhans cells that are up-regulated by cytokines are highly efficient at presenting allergens to T cells, activating a combined Th1/Th2 profile in chronic lesions. Thus, it appears that IgE antibody and the Th2 cytokine/chemokine milieu combine to play a major role in AD.

Several articles have speculated on the role of food-specific T cells in the pathophysiology of AD and have used the atopic patch test (APT) to provide further information.<sup>17–21</sup> In some patients who may have a delayed response to foods, authors hypothesize that the reactions may occur via high-affinity IgE receptors expressed on Langerhans and dendritic cells leading to allergen-specific T cell responses capable of promoting IgE production and delayed-type hypersensitivity reactions.

Genetic mutations resulting in clinical disease have provided additional insight into the potential relationship of AD and food allergy. Two disorders provide particularly compelling information. IPEX (immune dysregulation, polyendocrinopathy, enteropathy, X-linked) is a fatal disorder characterized by autoimmune enteropathy, endocrinopathy, severe dermatitis, elevated serum IgE and multiple food allergies.<sup>22</sup> IPEX syndrome results from a mutation in FOXP3, a protein that plays

a central role in the generation of regulatory T cells that are important for balance between oral tolerance and food allergy development. Similarly, mutations in the *SPINK5* gene have been associated with Netherton syndrome, an autosomal recessive disorder characterized by an AD-like rash and associated Th2 skewing and increased IgE levels. Japanese investigators have also found an association of *SPINK5* mutations in children with AD and food allergy.<sup>23</sup> More recently, a significant association has been found between loss-of-function mutations of filaggrin, a key epidermal protein for maintaining the barrier function of the skin, and food allergy.<sup>24,25</sup>

### BOX 47-1 ALLERGIC TRIGGERS OF ATOPIC DERMATITIS

#### FOOD ALLERGENS (MOST COMMON)

Milk  
Eggs  
Peanuts  
Soy  
Wheat  
Shellfish  
Fish

#### AEROALLERGENS

Pollen  
Mold  
Dust mite  
Animal dander  
Cockroach

#### MICROORGANISMS

Bacteria  
*Staphylococcus aureus*  
*Streptococcus* species  
Fungi/yeasts  
*Pityrosporum ovale/orbiculare*  
*Trichophyton* species  
Other yeast species (e.g. *Candida*, *Malassezia*)

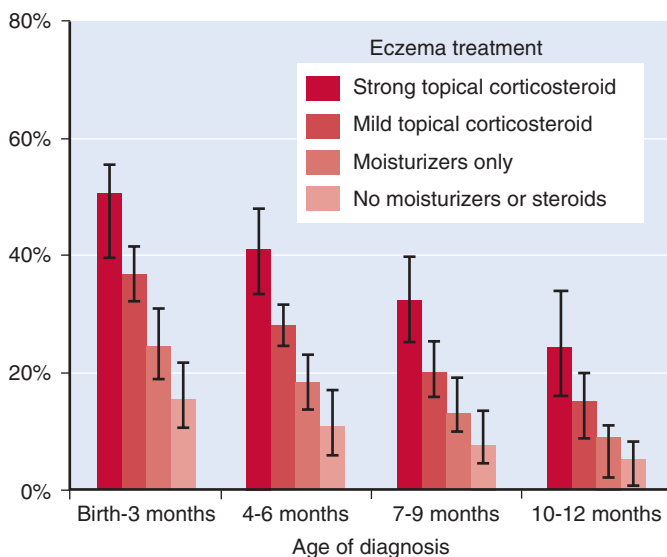

**Figure 47-1** The prevalence of infants allergic to foods (peanut, egg, sesame) is correlated with the age of diagnosis of eczema and treatment required for eczema. Infants diagnosed at a younger age and with increased severity of eczema had higher prevalence of food allergy. (From Martin PE & The HealthNuts Study Investigators. *Clin Exp Allergy* 2015;45(1):255–64.

## Laboratory Investigation

Several studies support a role for food-specific IgE antibodies in the pathogenesis of AD. Many patients have elevated concentrations of total IgE and food-specific IgE antibodies.<sup>26,27</sup> More than 50 years ago, Wilson and Walzer<sup>28,29</sup> demonstrated that the ingestion of foods would allow antigens to penetrate the gastrointestinal barrier and then be transported in the circulation to IgE-bearing mast cells in the skin. Additional investigations have shown that in children with food-specific IgE antibodies undergoing oral food challenges, positive challenges are accompanied by increases in plasma histamine concentration,<sup>30</sup> elaboration of eosinophil products<sup>31</sup> and activation of plasma eosinophils<sup>32</sup> (Box 47-2).

Children with AD who were chronically ingesting foods to which they were allergic were found to have increased 'spontaneous' basophil histamine release (SBHR) from peripheral blood basophils in vitro compared with children without food allergy or normal subjects.<sup>33</sup> After placement on the appropriate elimination diet, food-allergic children experienced significant clearing of their skin and a significant fall in their SBHR.<sup>33</sup> Other studies have shown that peripheral blood mononuclear cells from food-allergic patients with high SBHR elaborate specific cytokines termed histamine-releasing factors (HRFs) that activate basophils from food-sensitive, but not food-insensitive, patients. Furthermore, passive sensitization experiments in vitro with basophils from nonatopic donors and IgE from patients allergic to specific foods showed that basophils could be rendered sensitive to HRFs.<sup>33</sup>

Food allergen-specific T cells have been cloned from normal skin and active skin lesions in patients with AD.<sup>34,35</sup> There has been some disagreement in the literature about the validity of in vitro lymphocyte proliferation responses to specific foods in this disorder. There appears to be an increase in antigen-specific lymphocyte proliferation, but there is considerable overlap in individual responses with that seen in normal individuals. Cutaneous lymphocyte associated antigen (CLA) is a homing molecule that interacts with E-selectin and directs T cells to the skin. A study compared patients with milk-induced AD to control subjects with milk-induced gastrointestinal reactions without AD and with nonatopic control subjects.<sup>34</sup> Casein-reactive T cells from children with milk-induced AD had a significantly higher expression of CLA than *Candida albicans* reactive T cells from the same patients and either casein or *C. albicans* reactive T cells from the control groups.<sup>34</sup>

### BOX 47-2 LABORATORY INVESTIGATION OF ATOPIC DERMATITIS AND FOOD HYPERSENSITIVITY

- Positive food challenges produce increases in:
  - Plasma histamine concentrations
  - Activation of plasma eosinophils and eosinophil products
- Patients ingesting foods to which they are allergic have:
  - Increased spontaneous basophil histamine release
  - Histamine-releasing factors that activate basophils from food-sensitive patients
- Patients with milk allergy have:
  - Higher expression of milk-specific activated cutaneous lymphocyte antigen
- Patients with milk and peanut allergy (or food allergy?) have:
  - Differential patterns of expression of IgE binding epitopes that add insight into prognosis

An alternative and emerging paradigm has been championed by several investigators: that sensitization to food allergens occurs due to cutaneous exposure to antigen, e.g. peanut protein in house dust, due to poor barrier function in the skin of AD patients.<sup>10,36</sup> Lack and colleagues found an association between peanut allergy in preschool children with AD and increased exposure to peanut-based skin oils.<sup>37</sup> Subsequent studies from the same group noted a dose-response effect between environmental peanut exposure and the development of peanut allergy.<sup>38</sup> These observations have led to the hypothesis that environmental exposure to allergens through skin of infants with AD is responsible for allergen sensitivity and allergic disease.<sup>36</sup> Results using a murine model of filaggrin (FLG) deficiency support the theory that skin barrier dysfunction and inflammation can lead to epicutaneous sensitization to food proteins, e.g. ovalbumin<sup>39</sup> and peanut.<sup>40</sup> Further research should elucidate the role of filaggrin in AD and food allergies as well as identify additional factors involved in skin barrier function since more than 50% of patients with moderate to severe AD do not have *FLG* mutations and 60% of all carriers of *FLG*-null alleles do not have AD.<sup>41</sup>

## Clinical Studies

Multiple clinical studies have addressed the role of food allergy in AD. Investigators have shown that elimination of the relevant food allergen can lead to improvement in skin symptoms and that repeat challenges can lead to recurrence of symptoms.

A number of studies have addressed the therapeutic effect of dietary elimination in the treatment of AD. Atherton and colleagues<sup>42</sup> reported that two thirds of children with AD between the ages of 2 and 8 years showed marked improvement during a double-blind, cross-over trial of milk and egg exclusion. However, there were problems in this study, including high dropout and exclusion rates, as well as confounding variables such as environmental factors and other triggers of AD. Another trial by Neild and colleagues<sup>43</sup> was able to demonstrate improvement in some patients during the milk and egg exclusion phase, but no significant difference was seen in 40 patients completing the cross-over trial. Juto and colleagues<sup>44</sup> reported that approximately one third of AD patients had resolution of their rash and that one half improved on a highly restricted diet. The cumulative results of these studies support the role for food allergy in the exacerbation of AD. Notably, most of the trials failed to control for confounding factors such as other trigger factors, as well as the placebo effect or observer bias.

In one of the original prospective follow-up studies, Sampson and Scanlon<sup>45</sup> studied 34 patients with AD, of whom 17 had food allergy diagnosed by double-blind, placebo-controlled food challenges (DBPCFCs). These patients were placed on appropriate allergen elimination and experienced significant improvement in their clinical symptoms. At 1- to 2-year and 3- to 4-year follow-ups, the subjects were compared with control subjects who did not have food allergy and to children with food allergy who were not compliant with their diet. Food-allergic patients with appropriate dietary restriction demonstrated highly significant improvement in their AD compared with the control groups.

Lever and colleagues<sup>46</sup> performed a randomized controlled trial of egg elimination in young children with AD and a positive radioallergosorbent test (RAST) to eggs who presented to their dermatology clinic. At the end of this study, egg allergy

was confirmed by oral challenge, and 55 children who were allergic to egg were ultimately identified. There was a significant decrease in the skin area affected in the children avoiding eggs compared with the control subjects (percent involvement, 19.6% to 10.9% vs 21.9% to 18.9%). There was also a significant improvement in symptom score ( $P = .04$ ) for the children avoiding eggs.

Oral food challenges have been used to demonstrate that food allergens can induce symptoms of rash and pruritus in children with food allergy-related AD. Sampson and colleagues<sup>45,47,48</sup> and Eigenmann and colleagues<sup>49</sup> published a number of articles using DBPCFCs to identify causal food proteins that are involved as trigger factors of AD. In studies during the past 25 years, Sampson and colleagues have conducted more than 4,000 oral food challenges with greater than 40% of the challenges resulting in reaction (personal communication). These studies showed that cutaneous reactions occurred in 75% of the positive challenges, generally consisting of pruritic, morbilliform or macular eruptions in the predilection sites for AD. Isolated skin symptoms were seen in only 30% of the reactions; gastrointestinal (50%) and respiratory (45%) reactions also occurred. Almost all reactions occurred within the first hour of beginning the oral challenges. Clinical reactions to egg, milk, wheat and soy accounted for almost 75% of the reactions. Some patients had repeated reactions during a series of daily challenges and had increasingly severe AD, further showing that ingestion of the causal food protein can trigger pruritus and scratching with recrudescence of typical lesions of AD.

Subsequent studies confirmed that a limited number of foods cause clinical symptoms in younger patients with AD.<sup>50,51</sup> Milk, eggs and peanuts generally cause more than 75% of the IgE-mediated reactions. If soy, wheat, fish and tree nuts were added to this list of foods, more than 98% of the foods that cause clinical symptoms would be identified.

## Prevention

Longitudinal studies have been conducted in general population birth cohorts and cohorts of high-risk infants to determine the role of breastfeeding, maternal diet restriction during pregnancy and lactation, the use of hydrolyzed formulas and delayed food introduction on development of AD and other atopic diseases. These studies led to new recommendations for early nutritional interventions by the American Academy of Pediatrics in 2008.<sup>52</sup> A meta-analysis determined that exclusive breastfeeding during the first 3 months of life is associated with lower incidence rates of AD during childhood in children with a family history of atopy.<sup>53</sup> The authors concluded that breastfeeding should be strongly recommended to mothers of infants with a family history of atopy as a possible means of preventing AD.

In two series, infants from atopic families whose mothers excluded eggs, milk and fish from their diets during lactation (prophylaxis group) had significantly less AD and food allergy compared at 18 months with those infants whose mothers' diets were unrestricted.<sup>54,55</sup> Follow-up at 4 years showed that the prophylaxis group had less AD, but there was no difference in food allergy or respiratory allergy.<sup>55</sup> In a 2006 Cochrane review,<sup>56</sup> the authors concluded that dietary avoidance of allergenic foods by lactating mothers of infants with AD may reduce the severity of the eczema, however larger trials are needed to confirm this.

In the German Infant Nutritional Intervention Study (GINI),<sup>57</sup> 2,252 healthy term infants were randomized to receive

one of four blinded formulas during the first 4 months of life when breastfeeding was insufficient: partially (PHW) or extensively hydrolyzed whey (EHW), extensively hydrolyzed casein (EHC) or cow's milk (CM). These infants were followed for 6 years for allergic manifestations. The study showed a long-term preventive effect of hydrolyzed infant formulas for AD until age 6 years with the relative risk of a physician diagnosis of AD compared with CM of 0.79 (95% CI, 0.64–0.97) for PHW and 0.71 (95% CI, 0.58–0.88) for EHC. No preventive effect was seen for EHW. Similar findings were noted in a high-risk birth cohort of 120 infants from the Isle of Wight followed for 8 years.<sup>58</sup> In the prophylactic group, infants were either breastfed with the mother maintaining a low allergen diet or given extensively hydrolyzed formula and placed on an allergen elimination diet (egg, milk, soy, wheat, nuts, fish) and dust mite avoidance through age 12 months, and compared to control infants in routine care. Those in the intervention group were noted to have reduced asthma (OR 0.24), AD (OR 0.23), allergic rhinitis (OR 0.42) and atopy (OR 0.13) compared to the controls ( $P < .001$ ).

Timing of solid food introduction and its influence on AD has been examined as well. A study by Saarinen and Kajosaari<sup>59</sup> found that while exclusive breastfeeding for the first 6 months of life led to decreased AD at 1 year of age compared to early introduction of solids (at 3 months), no difference in the prevalence of AD was observed during follow-up at 5 years. Ferguson and Horwood<sup>60</sup> also noted an increased risk for AD with early introduction of a diverse number of solid foods in the first 4 months of life using a birth cohort of 1,265 children followed to the age of 10 years. In contrast, delayed introduction of solid foods has not been shown to have a protective effect against AD.<sup>61</sup> Thus, current recommendations encourage exclusive breastfeeding until 4–6 months of age as well as introduction of solid foods at 4–6 months of age.<sup>62</sup>

Vitamin D is another factor recently implicated in atopy, therefore several studies have explored its potential role in AD. In a study examining cord blood vitamin D levels in 231 high-risk infants from an Australian prospective birth cohort, reduced maternal vitamin D levels during pregnancy were noted to be significantly associated with eczema in the first year of life.<sup>63</sup> In addition, Peroni et al reported an association between vitamin D deficiency and increased severity of AD in children.<sup>64</sup> Vitamin D deficiency has also been noted to correlate with IgE-mediated food sensitization<sup>65</sup> as well as food allergy.<sup>66</sup> Recently, Baek et al<sup>67</sup> have suggested that severity of AD is independently associated with vitamin D status and allergic sensitization to foods.

Gut microbiota is hypothesized to have an immune regulatory role in protecting from allergic disorders. Thus, there has been interest in exploring the possibility of probiotic supplementation for the primary prevention of allergies in children at high risk for allergy (defined as those with a biological parent or sibling with current or history of allergic rhinitis, asthma, eczema or food allergy).<sup>62</sup> In a double-blind placebo-controlled trial of 241 mother-infant pairs, a significant reduction of risk for developing eczema during the first 24 months of life was seen in infants whose mothers received probiotics 2 months before delivery and during the first 2 months of breastfeeding.<sup>68</sup> Recent systematic reviews concluded that probiotic supplementation in pregnancy and early life moderately reduces the incidence and severity of atopic dermatitis.<sup>69,70</sup> Thus, World Allergy Organization (WAO) guidelines suggest that probiotics be used in pregnant women at high risk for allergy in their children, in

women who are breastfeeding infants at high risk for allergy, and in infants at high risk for allergy because studies have shown a benefit for the prevention of eczema.<sup>71</sup>

## Epidemiology of Food Allergy in Atopic Dermatitis

The prevalence of food allergy in patients with AD varies with the age of the patient and severity of AD. In a study of 2,184 Australian infants, investigators found that the earlier the age of onset of AD and the greater the severity of disease, the greater the frequency of associated high levels of food-specific IgE.<sup>72</sup> Lowe and colleagues<sup>73</sup> also noted that, in some infants, sensitization precedes and predicts the development of AD, while in others AD precedes and predicts the development of sensitization. In a study of children with AD, Burks and colleagues<sup>50,51</sup> diagnosed food allergy in approximately 35% of 165 patients with AD referred to both university allergy and university dermatology clinics. Many of the patients were referred to an allergist, which might lead to an ascertainment bias favoring food-allergic subjects, so Eigenmann and colleagues<sup>49</sup> addressed this potential bias by studying 63 unselected children with moderate to severe AD who were referred to a university dermatologist. After an evaluation including oral food challenges, 37% of these patients were diagnosed with food allergy. In another study<sup>74</sup> that evaluated more than 250 children with AD, investigators noted that increased severity of AD in the younger patients was directly correlated with the presence of food allergy. Additional studies in adults with severe AD are relatively limited and have not shown a significant role for food allergy<sup>75</sup> or success in reducing symptoms during trials of elimination diets.<sup>76</sup>

## Diagnosis

### GENERAL APPROACH

The diagnosis of food allergy in AD is complicated by several factors related to the disease: (1) the immediate response to ingestion of causal foods is down-regulated with repetitive ingestion, making obvious 'cause and effect' relations by history difficult to establish; (2) other environmental trigger factors (other allergens, irritants, infection) may play a role in the waxing and waning of the disease, obscuring the effect of dietary changes; and (3) patients have the ability to generate IgE to multiple allergens, many not associated with clinical symptoms, making diagnosis based solely on laboratory testing impossible (Box 47-3).

The National Institute of Allergy and Infectious Diseases (NIAID) guidelines for the diagnosis and management of food allergy suggest that a food allergy evaluation should be considered in children with moderate to severe AD.<sup>62</sup> As outlined in Chapter 41, a careful medical history is essential in the diagnostic work-up (Figure 47-2). For breastfed infants, a maternal dietary history is also helpful because of the passage of food proteins in breast milk. Selected foods are then evaluated by tests for specific IgE (e.g. prick skin test [PST], food-specific IgE tests), as reviewed in Chapter 41. A small number of foods account for more than 90% of reactions<sup>47,51,77</sup> (Table 47-1). Food additives have been documented to cause flaring of AD, but with a much lower prevalence.<sup>78–80</sup> Patients with AD will often have positive skin tests and/or food-specific IgE tests for several



### BOX 47-3 FACTORS RELATED TO ATOPIC DERMATITIS THAT COMPLICATE THE DIAGNOSIS OF FOOD ALLERGY

Immediate response to ingestion of causal foods is apparently down-regulated with repetitive ingestion, making obvious 'cause and effect' relations by history difficult to establish. Other environmental trigger factors (other allergens, irritants, infection) may play a role in the waxing and waning of the disease, obscuring the effect of dietary changes. Patients have the ability to generate IgE to multiple allergens, making diagnosis based solely on laboratory testing impossible.

TABLE 47-1 Foods Responsible for the Majority of Food-Allergic Reactions

Infants	Children	Older Children/Adults
Cow's milk	Cow's milk	Peanuts
Eggs	Eggs	Tree nuts
Peanuts	Peanuts	Fish
Soy	Soy	Shellfish
	Wheat	
	Tree nuts (walnut, cashew, etc.)	
	Fish	
	Shellfish	

From Sicherer SH, Sampson HA. *J Allergy Clin Immunol* 1999;104:S114–22.

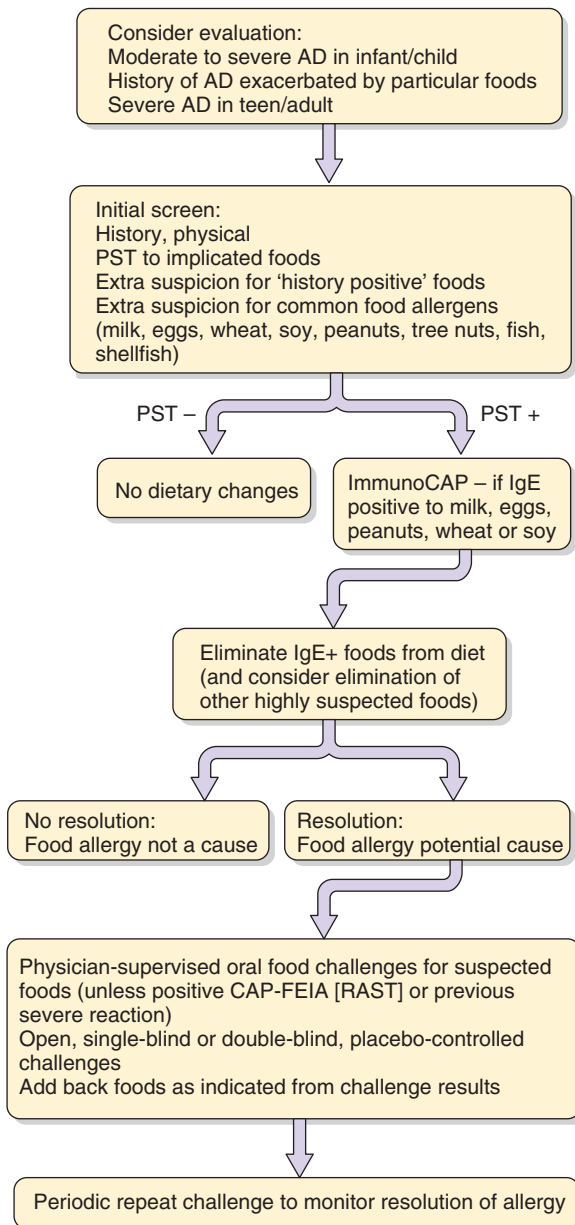

**Figure 47-2** General approach to evaluation of food allergy in atopic dermatitis (AD). CAP-FEIA – ImmunoCAP® fluorezymeimmunoassay, PST – prick skin test. (From Sicherer SH, Sampson HA. *J Allergy Clin Immunol* 1999;104:S114–22.)

members of a botanical family (e.g. wheat and grass) or animal species (e.g. egg and chicken), more likely indicating immunologic cross-reactivity but not symptomatic intra-botanical or intra-species cross-reactivity. Therefore, the practice of avoiding all foods within a botanical family when one member is suspected of provoking allergic symptoms generally appears to be unwarranted.

After the laboratory studies are performed, the best initial treatment would be elimination of the suspected food from the diet, followed by a food challenge if indicated (Table 47-2). No further testing or food challenges may be necessary in cases of severe, acute reactions or if dramatic improvement in skin disease occurs. Because symptoms are chronic in AD and often a large number of foods are implicated, it is generally necessary to perform diagnostic oral food challenges.

## Oral Food Challenges

As outlined in Chapter 41, oral food challenges are invaluable in the appropriate diagnosis and management of patients with AD and possible food allergy. Oral challenges are also necessary to evaluate the resolution (or development of tolerance) of the specific food allergy and can be performed safely.<sup>81,82</sup> However, oral challenges are contraindicated when there is a clear, recent history of food-induced airway reactivity or anaphylaxis. Additionally, patients should not be instructed to perform home food challenges because of the potential risk of severe allergic reactions.<sup>83</sup>

## Management

The elimination of food proteins can often be a difficult task, and incomplete elimination of the offending food can lead to confusion and inconclusive results during an open trial of dietary elimination. For example, in a milk-free diet, patients must be instructed not only to avoid all milk products but also to read all food labels in order to identify 'hidden' sources of cow's milk protein, as reviewed in Chapter 48.

## Natural History

Most children outgrow their allergies to milk, eggs, wheat and soy<sup>84</sup> (Box 47-4), although studies have shown that the rate of resolution of some food allergens (e.g. egg and milk) may be slower than previously described. In one study of the natural history of egg allergy in children followed in a pediatric allergy

TABLE 47-2

### Performance Characteristics of 90% Specificity Diagnostic Decision Points Generated in the Prospective Study in Diagnosing Food Allergy in 100 Consecutive Children and Adolescents Referred for Evaluation of Food Hypersensitivity

Allergen	Decision Point (kU/L)	Sensitivity (%)	Specificity (%)	Efficiency (%)	PPV (%)	NPV (%)
Eggs	7	61	95	68	98	38
Milk	15	57	94	69	95	53
Peanuts	14	57	100	84	100	36
Fish	3	63	91	87	56	93
Soybean	30	44	94	81	73	82
Wheat	26	61	92	84	74	87

From Sampson HA. *J Allergy Clin Immunol* 2001;107:891–6.

NPV, Negative predictive value; PPV, positive predictive value.

Given are PPV and NPV of food-specific IgE concentrations for predicting reactions on oral challenge by using the ImmunoCAP® system.

The PPVs for eggs, milk, and peanuts on the basis of the 90% specificity values are excellent (i.e. 98–100%) but are less predictive for fish, wheat and soy (i.e. 56%, 73% and 74%, respectively).

#### BOX 47-4 NATURAL HISTORY OF FOOD HYPERSENSITIVITY

##### FOOD ALLERGY OFTEN OUTGROWN BY ADOLESCENCE

Milk  
Eggs  
Soy  
Wheat

##### FOOD ALLERGY OFTEN NOT OUTGROWN BY ADOLESCENCE

Peanuts  
Tree nuts  
Fish  
Shellfish

practice, investigators found the age distribution of resolution of allergy to be 4% by age 4 years, 12% by age 6 years, 37% by age 10 years, and 68% by age 16 years.<sup>85</sup> The egg-specific IgE level was predictive of allergy outcome and it can be used in combination with skin testing results to counsel patients on prognosis.<sup>86</sup> Perry et al also showed that food-specific IgE levels are helpful in determining the likelihood that a child has outgrown their food allergy.<sup>87</sup> Patients allergic to peanuts, tree nuts, fish and shellfish are much less likely to lose their clinical reactivity.<sup>88,89</sup> It does appear, however, that approximately 20% of patients who have a reaction to peanuts early in life may outgrow

their sensitivity.<sup>89</sup> Only approximately 9% of patients with tree nut allergy will outgrow their allergy.<sup>90</sup> Clinical reactivity is lost over time more quickly than the loss of food-specific IgE measured by PST or serum food-specific IgE testing.<sup>87</sup> Certainly, children with food allergy need to be followed at regular intervals with food-specific IgE testing and PST, followed by oral food challenge when indicated, to determine when clinical tolerance is achieved.

## Conclusions

The number of triggers associated with disease pathogenesis and clinical symptoms for patients with AD is vast. The role of allergens as a trigger factor, particularly food allergens, early in life is clearly very important. A careful history and appropriate diagnostic testing coupled with a comprehensive treatment program can be disease modifying and life altering for patients with AD.

## Helpful Website

The Food Allergy Research and Education website ([www.foodallergy.org](http://www.foodallergy.org))

The complete reference list can be found on the companion Expert Consult website at <http://www.expertconsult.inkling.com>.

## KEY REFERENCES

- Martin PE, Eckert JK, Koplin JJ, Lowe AJ, Gurrin LC, Dharmage SC, et al. Which infants with eczema are at risk of food allergy? Results from a population-based cohort. *Clin Exp Allergy* 2015;45:255–64.
- Venkataraman D, Soto-Ramírez N, Kurukulaaratchy RJ, Holloway JW, Karmaus W, Ewart SL, et al. Filaggrin loss-of-function mutations are associated with food allergy in childhood and adolescence. *J Allergy Clin Immunol* 2014;134:876–82.
- O'Regan GM, Irvine AD. The role of filaggrin in the atopic diathesis. *Clin Exp Allergy* 2010;40:965–72.
- Eigenmann PA, Sicherer SH, Borkowski TA, Cohen BA, Sampson HA. Prevalence of IgE-mediated food allergy among children with atopic dermatitis. *Pediatrics* 1998;101:E8.
- Greer FR, Sicherer SH, Burks AW. Effects of early nutritional interventions on the development of atopic disease in infants and children: the role of maternal dietary restriction, breastfeeding, timing of introduction of complementary foods, and hydrolyzed formulas. *Pediatrics* 2008;121:183–91.
- von Berg A, Filipiak-Pittroff B, Krämer U, Link E, Bollrath C, Brockow I, et al. Preventive effect of hydrolyzed infant formulas persists until age 6 years: long-term results from the German Infant Nutritional Intervention Study (GINI). *J Allergy Clin Immunol* 2008;121:1442–7.
- Boyce JA, Assa'ad A, Burks AW, Jones SM, Sampson HA, Wood RA, et al. Guidelines for the diagnosis and management of food allergy in the United States: summary of the NIAID-Sponsored Expert Panel Report. *J Allergy Clin Immunol* 2010;126(Suppl. 6):1105–18.
- Baek JH, Shin YH, Chung IH, Kim HJ, Yoo EG, Yoon JW, et al. The link between serum vitamin D level, sensitization to food allergens, and the severity of atopic dermatitis in infancy. *J Pediatr* 2014;165:849–54.
- Fiocchi A, Pawankar R, Cuello-Garcia C, Ahn K, Al-Hammadi S, Agarwal A, et al. World Allergy Organization-McMaster University Guidelines for Allergic Disease Prevention (GLAD-P): Probiotics. *World Allergy Organ J* 2015;8:4.
- Hill DJ, Hosking CS, de Benedictis FM, Oranje AP, Diepgen TL, Bauchau V, et al. Confirmation of the association between high levels of immunoglobulin E food sensitization and eczema in infancy: an international study. *Clin Exp Allergy* 2008;38:161–8.

## REFERENCES

- Besnier E. Première note et observations préliminaires pour servir d'introduction à l'étude des prurigos diathésiques. *Ann de Dermatol* 1892;23:634.
- Coca A, Cooke R. On the classification of the phenomena of hypersensitiveness. *J Immunol* 1923;18:163–82.
- Wise F, Sulzberger M. Eczematous eruptions. *Year Book of Dermatology and Syphilology*. Chicago: Year Book Medical; 1933.
- Illi S, von Mutius E, Lau S, Nickel R, Grüber C, Niggemann B, et al. The natural course of atopic dermatitis from birth to age 7 years and the association with asthma. *J Allergy Clin Immunol* 2004;113:925–31.
- Martin PE, Eckert JK, Koplin JJ, Lowe AJ, Gurrin LC, Dharmage SC, et al. Which infants with eczema are at risk of food allergy? Results from a population-based cohort. *Clin Exp Allergy* 2015;45:255–64.
- Schloss O. Allergy to common foods. *Trans Am Pediatr Soc* 1915;27:62–8.
- Talbot F. Eczema in childhood. *Med Clin North Am* 1918;1:985–96.
- Blackfan K. A consideration of certain aspects of protein hypersensitiveness in children. *Am J Med Sci* 1920;160:341–50.
- Hanifin JM. Critical evaluation of food and mite allergy in the management of atopic dermatitis. *J Dermatol* 1997;24:495–503.
- Bieber T. Atopic dermatitis. *N Engl J Med* 2008;358:1483–94.
- Leung DY, Boguniewicz M, Howell MD, Nomura I, Hamid QA. New insights into atopic dermatitis. *J Clin Invest* 2004;113:651–7.
- Solley GO, Gleich GJ, Jordan RE, Schroeter AL. The late phase of the immediate wheal and flare skin reaction: its dependence upon IgE antibodies. *J Clin Invest* 1976;58:408–20.
- Hamid Q, Boguniewicz M, Leung DY. Differential in situ cytokine gene expression in acute versus chronic atopic dermatitis. *J Clin Invest* 1994;94:870–6.
- Hamid Q, Naseer T, Minshall EM, Song YL, Boguniewicz M, Leung DY. In vivo expression of IL-12 and IL-13 in atopic dermatitis. *J Allergy Clin Immunol* 1996;98:225–31.
- Tsicopoulos A, Hamid Q, Varney V, Ying S, Moqbel R, Durham SR, et al. Preferential messenger RNA expression of Th1-type cells (IFN- $\gamma$ +, IL-2+) in classical delayed-type (tuberculin) hypersensitivity reactions in human skin. *J Immunol* 1992;148:2058–61.
- Leiferman KM, Ackerman SJ, Sampson HA, Haugen HS, Venencie PY, Gleich GJ. Dermal deposition of eosinophil-granule major basic protein in atopic dermatitis: comparison with onchocerciasis. *N Engl J Med* 1985;313:282–5.
- Niggemann B, Reibel S, Wahn U. The atopy patch test (APT): a useful tool for the diagnosis of food allergy in children with atopic dermatitis. *Allergy* 2000;55:281–5.
- Niggemann B, Reibel S, Roehr CC, Felger D, Ziegert M, Sommerfeld C, et al. Predictors of positive food challenge outcome in non-IgE-mediated reactions to food in children with atopic dermatitis. *J Allergy Clin Immunol* 2001;108:1053–8.
- Kekki OM, Turjanmaa K, Isolauri E. Differences in skin-prick and patch-test reactivity are related to the heterogeneity of atopic eczema in infants. *Allergy* 1997;52:755–9.
- Mehl A, Rolinck-Werninghaus C, Staden U, Verstege A, Wahn U, Beyer K, et al. The atopy patch test in the diagnostic workup of suspected food-related symptoms in children. *J Allergy Clin Immunol* 2006;118:923–9.
- Devillers AC, de Waard-van der Spek FB, Mulder PG, Oranje AP. Delayed- and immediate-type reactions in the atopy patch test with food allergens in young children with atopic dermatitis. *Pediatr Allergy Immunol* 2009;20:53–8.
- Torgerson TR, Linane A, Moes N, Anover S, Mateo V, Rieux-Laucat F, et al. Severe food allergy as a variant of IPEX syndrome caused by a deletion in a noncoding region of the FOXP3 gene. *Gastroenterology* 2007;132:1705–17.
- Kusunoki T, Okafuji I, Yoshioka T, Saito M, Nishikomori R, Heike T, et al. SPINK5 polymorphism is associated with disease severity and food allergy in children with atopic dermatitis. *J Allergy Clin Immunol* 2005;115:636–8.
- Brown SJ, Asai Y, Cordell HJ, Campbell LE, Zhao Y, Liao H, et al. Loss-of-function variants in the filaggrin gene are a significant risk factor for peanut allergy. *J Allergy Clin Immunol* 2011;127:661–7.
- Venkataraman D, Soto-Ramírez N, Kurukulaaratchy RJ, Holloway JW, Karmaus W, Ewart SL, et al. Filaggrin loss-of-function mutations are associated with food allergy in childhood and adolescence. *J Allergy Clin Immunol* 2014;134:876–82.
- Johnson EE, Irons JS, Patterson R, Roberts M. Serum IgE concentration in atopic dermatitis: relationship to severity of disease and presence of atopic respiratory disease. *J Allergy Clin Immunol* 1974;54:94–9.
- Boguniewicz M, Schmid-Grendelmeier P, Leung DY. Atopic dermatitis. *J Allergy Clin Immunol* 2006;118:40–3.
- Walzer M. Studies in absorption of undigested proteins in human beings. I. A simple direct method of studying the absorption of undigested protein. *J Immunol* 1927;14:143–74.
- Wilson S, Walzer M. Absorption of undigested proteins in human beings. IV. Absorption of unaltered egg protein in infants. *Am J Dis Child* 1935;50:49–54.
- Sampson HA, Jolie PL. Increased plasma histamine concentrations after food challenges in children with atopic dermatitis. *N Engl J Med* 1984;311:372–6.
- Suomalainen H, Soppi E, Isolauri E. Evidence for eosinophil activation in cow's milk allergy. *Pediatr Allergy Immunol* 1994;5:27–31.
- Magnarin M, Knowles A, Ventura A, Vita F, Fanti L, Zucchi G. A role for eosinophils in the pathogenesis of skin lesions in patients with food-sensitive atopic dermatitis. *J Allergy Clin Immunol* 1995;96:200–8.
- Sampson HA, Broadbent KR, Bernhisel-Broadbent J. Spontaneous release of histamine from basophils and histamine-releasing factor in patients with atopic dermatitis and food hypersensitivity. *N Engl J Med* 1989;321:228–32.
- Abernathy-Carver KJ, Sampson HA, Picker LJ, Leung DY. Milk-induced eczema is associated with the expansion of T cells expressing cutaneous lymphocyte antigen. *J Clin Invest* 1995;95:913–18.
- van Reijssen FC, Bruijnzeel-Koomen CA, Kalthoff FS, Maggi E, Romagnani S, Westland JK, et al. Skin-derived aeroallergen-specific T cell clones of Th2 phenotype in patients with atopic dermatitis. *J Allergy Clin Immunol* 1992;90:184–93.
- Lack G. Epidemiologic risks for food allergy. *J Allergy Clin Immunol* 2008;121:1331–6.
- Lack G, Fox D, Northstone K, Golding J; Avon Longitudinal Study of Parents and Children Study Team. Factors associated with the development of peanut allergy in childhood. *N Engl J Med* 2003;348:977–85.
- Fox AT, Sasieni P, du Toit G, Syed H, Lack G. Household peanut consumption as a risk factor for the development of peanut allergy. *J Allergy Clin Immunol* 2009;123:417–23.
- Oyoshi MK, Murphy GF, Geha RS. Filaggrin-deficient mice exhibit TH17-dominated skin inflammation and permissiveness to epicutaneous sensitization with protein antigen. *J Allergy Clin Immunol* 2009;124:485–93, 493.e1.
- Dunkin D, Berin MC, Mayer L. Allergic sensitization can be induced via multiple physiologic routes in an adjuvant-dependent manner. *J Allergy Clin Immunol* 2011;128:1251–8.
- O'Regan GM, Irvine AD. The role of filaggrin in the atopic diathesis. *Clin Exp Allergy* 2010;40:965–72.
- Atherton DJ, Sewell M, Soothill JF, Wells RS, Chilvers CE. A double-blind controlled crossover trial of an antigen-avoidance diet in atopic eczema. *Lancet* 1978;1:401–3.
- Neild VS, Marsden RA, Bailes JA, Bland JM. Egg and milk exclusion diets in atopic eczema. *Br J Dermatol* 1986;114:117–23.
- Juto P, Engberg S, Winberg J. Treatment of infantile atopic dermatitis with a strict elimination diet. *Clin Allergy* 1978;8:493–500.
- Sampson HA, Scanlon SM. Natural history of food hypersensitivity in children with atopic dermatitis. *J Pediatr* 1989;115:23–7.
- Lever R, MacDonald C, Waugh P, Aitchison T. Randomised controlled trial of advice on an egg exclusion diet in young children with atopic eczema and sensitivity to eggs. *Pediatr Allergy Immunol* 1998;9:13–19.
- Sampson HA, McCaskill CC. Food hypersensitivity and atopic dermatitis: evaluation of 113 patients. *J Pediatr* 1985;107:669–75.
- Sampson HA, Metcalfe DD. Food allergies. *JAMA* 1992;268:2840–4.
- Eigenmann PA, Sicherer SH, Borkowski TA, Cohen BA, Sampson HA. Prevalence of IgE-mediated food allergy among children with atopic dermatitis. *Pediatrics* 1998;101:E8.
- Burks AW, Mallory SB, Williams LW, Shirrell MA. Atopic dermatitis: clinical relevance of food hypersensitivity reactions. *J Pediatr* 1988;113:447–51.
- Burks AW, James JM, Hiegel A, Wilson G, Wheeler JG, Jones SM, et al. Atopic dermatitis and food hypersensitivity reactions. *J Pediatr* 1998;132:132–6.
- Greer FR, Sicherer SH, Burks AW. Effects of early nutritional interventions on the development of atopic disease in infants and children: the role of maternal dietary restriction, breastfeeding, timing of introduction of complementary foods, and hydrolyzed formulas. *Pediatrics* 2008;121:183–91.
- Gdalevich M, Mimouni D, David M, Mimouni M. Breast-feeding and the onset of atopic dermatitis in childhood: a systematic review and meta-analysis of prospective studies. *J Am Acad Dermatol* 2001;45:520–7.

54. Hattevig G, Kjellman B, Sigurs N, Björkstén B, Kjellman NI. Effect of maternal avoidance of eggs, cow's milk and fish during lactation upon allergic manifestations in infants. *Clin Exp Allergy* 1989;19:27–32.
55. Sigurs N, Hattevig G, Kjellman B. Maternal avoidance of eggs, cow's milk, and fish during lactation: effect on allergic manifestations, skin-prick tests, and specific IgE antibodies in children at age 4 years. *Pediatrics* 1992;89(4 Pt 2):735–9.
56. Kramer MS, Kakuma R. Maternal dietary antigen avoidance during pregnancy or lactation, or both, for preventing or treating atopic disease in the child. *Cochrane Database Syst Rev* 2006;3:CD000133.
57. von Berg A, Filipiak-Pittroff B, Krämer U, Link E, Bollrath C, Brockow I, et al. Preventive effect of hydrolyzed infant formulas persists until age 6 years: long-term results from the German Infant Nutritional Intervention Study (GINI). *J Allergy Clin Immunol* 2008;121:1442–7.
58. Arshad SH, Bateman B, Sadeghnejad A, Gant C, Matthews SM. Prevention of allergic disease during childhood by allergen avoidance: the Isle of Wight prevention study. *J Allergy Clin Immunol* 2007;119:307–13.
59. Saarinen UM, Kajosaari M. Breastfeeding as prophylaxis against atopic disease: prospective follow-up study until 17 years old. *Lancet* 1995;346:1065–9.
60. Fergusson DM, Horwood LJ. Early solid food diet and eczema in childhood: a 10-year longitudinal study. *Pediatr Allergy Immunol* 1994;5(Suppl. 6):44–7.
61. Zutavern A, Brockow I, Schaaf B, Bolte G, von Berg A, Diez U, et al. Timing of solid food introduction in relation to atopic dermatitis and atopic sensitization: results from a prospective birth cohort study. *Pediatrics* 2006;117:401–11.
62. Boyce JA, Assa'ad A, Burks AW, Jones SM, Sampson HA, Wood RA, et al. Guidelines for the diagnosis and management of food allergy in the United States: summary of the NIAID-Sponsored Expert Panel Report. *J Allergy Clin Immunol* 2010;126(Suppl. 6):1105–18.
63. Jones AP, Palmer D, Zhang G, Prescott SL. Cord blood 25-hydroxyvitamin D3 and allergic disease during infancy. *Pediatrics* 2012;130:e1128–35.
64. Peroni DG, Piacentini GL, Cametti E, Chinellato I, Boner AL. Correlation between serum 25-hydroxyvitamin D levels and severity of atopic dermatitis in children. *Br J Dermatol* 2011;164:1078–82.
65. Sharief S, Jariwala S, Kumar J, Muntner P, Melamed ML. Vitamin D levels and food and environmental allergies in the United States: results from the National Health and Nutrition Examination Survey 2005–2006. *J Allergy Clin Immunol* 2011;127:1195–202.
66. Allen KJ, Koplin JJ, Ponsonby AL, Gurrin LC, Wake M, Vuillermier P, et al. Vitamin D insufficiency is associated with challenge-proven food allergy in infants. *J Allergy Clin Immunol* 2013;131:1109–16, 1116.e1–6.
67. Baek JH, Shin YH, Chung IH, Kim HJ, Yoo EG, Yoon JW, et al. The link between serum vitamin D level, sensitization to food allergens, and the severity of atopic dermatitis in infancy. *J Pediatr* 2014;165:849–54.
68. Rautava S, Kainonen E, Salminen S, Isolauri E. Maternal probiotic supplementation during pregnancy and breast-feeding reduces the risk of eczema in the infant. *J Allergy Clin Immunol* 2012;130:1355–60.
69. Foolad N, Brezinski EA, Chase EP, Armstrong AW. Effect of nutrient supplementation on atopic dermatitis in children: a systematic review of probiotics, prebiotics, formula, and fatty acids. *JAMA Dermatol* 2013;149:350–5.
70. Pelucchi C, Chatenoud L, Turati F, Galeone C, Moja L, Bach JF, et al. Probiotics supplementation during pregnancy or infancy for the prevention of atopic dermatitis: a meta-analysis. *Epidemiology* 2012;23:402–14.
71. Fiocchi A, Pawankar R, Cuello-Garcia C, Ahn K, Al-Hammadi S, Agarwal A, et al. World Allergy Organization-McMaster University Guidelines for Allergic Disease Prevention (GLAD-P): Probiotics. *World Allergy Organ J* 2015;8:4.
72. Hill DJ, Hosking CS, de Benedictis FM, Oranje AP, Diepgen TL, Bauchau V, et al. Confirmation of the association between high levels of immunoglobulin E food sensitization and eczema in infancy: an international study. *Clin Exp Allergy* 2008;38:161–8.
73. Lowe AJ, Abramson MJ, Hosking CS, Carlin JB, Bennett CM, Dharmage SC, et al. The temporal sequence of allergic sensitization and onset of infantile eczema. *Clin Exp Allergy* 2007;37:536–42.
74. Guillet G, Guillet MH. Natural history of sensitizations in atopic dermatitis. A 3-year follow-up in 250 children: food allergy and high risk of respiratory symptoms. *Arch Dermatol* 1992;128:187–92.
75. de Maat-Bleeker F, Bruijnzeel-Koomen C. Food allergy in adults with atopic dermatitis. *Monogr Allergy* 1996;32:157–63.
76. Munkvad M, Danielsen L, Høj L, Povlsen CO, Secher L, Svegaard E, et al. Antigen-free diet in adult patients with atopic dermatitis: a double-blind controlled study. *Acta Derm Venereol* 1984;64:524–8.
77. Bock SA, Atkins FM. Patterns of food hypersensitivity during sixteen years of double-blind, placebo-controlled food challenges. *J Pediatr* 1990;117:561–7.
78. Young E, Patel S, Stoneham M, Rona R, Wilkinson JD. The prevalence of reaction to food additives in a survey population. *J R Coll Physicians Lond* 1987;21:241–7.
79. Fuglsang G, Madsen G, Halken S, Jørgensen S, Ostergaard PA, Osterballe O. Adverse reactions to food additives in children with atopic symptoms. *Allergy* 1994;49:31–7.
80. Sampson HA, Aceves S, Bock SA, James J, Jones S, Lang D, et al. Food allergy: a practice parameter update-2014. *J Allergy Clin Immunol* 2014;134:1016–25.e43.
81. Perry TT, Matsui EC, Conover-Walker MK, Wood RA. Risk of oral food challenges. *J Allergy Clin Immunol* 2004;114:1164–8.
82. Mankad VS, Williams LW, Lee LA, LaBelle GS, Anstrom KJ, Burks AW. Safety of open food challenges in the office setting. *Ann Allergy Asthma Immunol* 2008;100:469–74.
83. David TJ. Hazards of challenge tests in atopic dermatitis. *Allergy* 1989;44(Suppl. 9):101–7.
84. Bock SA. The natural history of food sensitivity. *J Allergy Clin Immunol* 1982;69:173–7.
85. Savage JH, Matsui EC, Skripak JM, Wood RA. The natural history of egg allergy. *J Allergy Clin Immunol* 2007;120:1413–17.
86. Knight AK, Shreffler WG, Sampson HA, Sicherer SH, Noone S, Mofidi S, et al. Skin prick test to egg white provides additional diagnostic utility to serum egg white-specific IgE antibody concentration in children. *J Allergy Clin Immunol* 2006;117:842–7.
87. Perry TT, Matsui EC, Conover-Walker MK, Wood RA. The relationship of allergen-specific IgE levels and oral food challenge outcome. *J Allergy Clin Immunol* 2004;114:144–9.
88. Skolnick HS, Conover-Walker MK, Koerner CB, Sampson HA, Burks W, Wood RA. The natural history of peanut allergy. *J Allergy Clin Immunol* 2001;107:367–74.
89. Fleischer DM, Conover-Walker MK, Christie L, Burks AW, Wood RA. The natural progression of peanut allergy: resolution and the possibility of recurrence. *J Allergy Clin Immunol* 2003;112:183–9.
90. Fleischer DM, Conover-Walker MK, Matsui EC, Wood RA. The natural history of tree nut allergy. *J Allergy Clin Immunol* 2005;116:1087–93.



# Management of Food Allergy

MARION GROETCH | HUGH A. SAMPSON

## KEY POINTS

- The management of food allergy entails dietary avoidance of the identified allergen to prevent chronic and acute food allergic reactions.
- Allergen elimination diets should not be prescribed lightly as they present great challenges to families and come with potential social, psychological, financial and nutritional burdens.
- Patients with food allergies and their caregivers must learn how to read and interpret product labels to successfully identify and eliminate food allergens.
- Children with food allergies may have inadequate nutrient intake and poor growth if the elimination diet is not well designed to substitute for nutrients lost to the elimination diet.
- The use of nutritionally appropriate substitute formulas and foods may be required.

## Overview

The therapeutic management of food allergy entails dietary avoidance of the identified allergen to prevent chronic and acute food allergic reactions. Many alternative immunomodulatory approaches are being explored as a means to prevent immunoglobulin E (IgE)-mediated food allergic reactions, although most have not yet moved into clinical practice. Therefore, at this time, with the exception of extensively heated (baked) milk or egg proteins for a subset of patients with milk and egg allergy, strict dietary avoidance is the only consistently viable management option.<sup>1-4</sup>

Allergen elimination diets present great challenges to families and come with potential social, psychological, financial and nutritional burdens.<sup>5-10</sup> Food is an integral part of social gatherings and without adequate planning the child and family may feel unable to participate fully in daily activities. Going to parties, eating in friends' homes, even going to school or camp requires planning so that these opportunities can be safely enjoyed. Eating competence is also vitally important to the socialization of the child, and children with food allergies may have food aversions and self-limited diets beyond the elimination diet (see Chapter 42). Anxiety issues may even arise about eating and food in general, which will further impact the child's ability to participate fully in activities. Shopping and meal preparation requires significantly more time when avoiding allergens, and specialty allergen-free foods can be more expensive.

Lastly, elimination diets may impact nutrient intake; great care must be taken to plan for a diet that continues to provide appropriate nutrition for growth and development. Rickets, vitamin and mineral deficiencies, suboptimal growth and failure to thrive have all been associated with food elimination diets.<sup>11</sup>

In addition to comprehensive education on how to recognize and treat food allergic reactions (see Chapter 58), food allergy management entails teaching the family how to avoid the allergen, manage the allergy in all areas of daily living, and provide a nutritionally balanced diet within the context of the allergen avoidance diet. The goal of providing extensive education is to reduce the risk of accidental allergen exposure, as well as to empower the family, and eventually the child, to participate in all daily activities while avoiding the food to which they are allergic. (See [Box 48-1](#) for a sample elimination diet with substitutions.) Living with food allergies is a daily challenge but, with planning, activities can be safe and manageable, and the allergen avoidance diet nutritionally complete and enjoyable.

## Avoidance Diets – General

Elimination diet education begins with knowing how to identify the allergen in the food supply. The elimination of a single allergen from the diet may seem an easy task. If the allergen plays a minor role in our food supply, such as cashew nut, the task may be simple enough. On the other hand, if the allergen is pervasive in our food supply, such as milk or wheat, avoidance issues become much more complex. Avoidance of a single allergen such as cow's milk necessitates avoidance of many common foods including not only milk, butter, cheese, yogurt and ice cream, but also numerous manufactured products such as crackers, breads, cookies, cereals, cakes, and processed meats and cold cuts that may also contain milk protein as an ingredient. Allergen avoidance sheets are available ([www.foodallergy.org](http://www.foodallergy.org) or [www.cofargroup.org](http://www.cofargroup.org) – click on Food Allergy Education Program) and are helpful when used as a starting point for allergen avoidance education. Allergen avoidance sheets identify foods and ingredients that typically contain the allergen, in addition to identifying situations that may require special caution. It should be noted that avoidance sheets do not provide the extensive education needed for strict dietary elimination.

## LABEL READING

Those shopping for a family member with food allergies must understand how to read and interpret product labels to successfully identify and eliminate food allergens.<sup>12</sup>

Food labeling legislation is dependent on the country or region in which the product is sold. Ingredients considered

**BOX 48-1 SAMPLE ELIMINATION DIET****BREAKFAST**

Gluten-free oat pancakes<sup>a</sup> or oatmeal with blueberries (or cooked blueberry compote)  
100% pure maple syrup  
Calcium fortified orange juice – 4 ounces

**SNACK**

Fresh watermelon or applesauce  
Buckwheat or crispy rice crackers with white bean spread (white beans pureed with olive oil)

**LUNCH**

Homemade chicken fingers<sup>b</sup>  
Baked sweet potato fries or mashed potatoes made with rice milk and milk-free, soy-free margarine  
Carrot and red pepper strips with vinaigrette for dipping (or cooked carrots with milk-free, soy-free margarine)  
Enriched alternative milk beverage or commercial hypoallergenic formula

**SNACK**

Enriched alternative milk beverage or commercial hypoallergenic formula  
Homemade Birthday Brownie

**DINNER**

Turkey meatballs in tomato sauce (use a fruit puree to bind the meat and a gluten-free breadcrumb or a dry infant oat or rice cereal as a breadcrumb substitute)  
Brown rice or quinoa pasta with olive oil  
Steamed broccoli florets  
Enriched grain 'milk' or commercial hypoallergenic formula  
Fresh peach (or canned peaches packed in own juice)  
This sample menu eliminates milk, egg, wheat, soy, peanut, tree nut, fish and shellfish. For a strict diagnostic elimination diet, you may choose to substitute the cooked fruits and vegetables for the raw versions. Serving size and texture modifications should be individualized and based on the child's nutritional needs and feeding skills.

<sup>a</sup>*Sophie Safe Cooking* by Emily Hendrix.

<sup>b</sup>*Eight Degrees of Ingredients* by Melisa K. Priem.

<sup>c</sup>*The Food Allergy News Cookbook* by members of The Food Allergy Network.

major allergens based on the labeling laws of a specific country or region are listed in [Table 48-1](#).

In the United States of America (USA), The Food Allergen Labeling and Consumer Protection Act (FALCPA) mandates clear, plain language labeling of all ingredients derived from the foods considered major allergens. Those foods considered major allergens in the USA are listed in [Table 48-1](#).<sup>13</sup> The plain language stipulation requires the presence of a major food allergen to be listed, using its common name (e.g. milk) rather than a scientific term (e.g. casein, whey) on the product label in one of the following ways:

- In parentheses, following the food protein derivative, for example: casein (milk)
- In the ingredient list, for example: milk, wheat, peanut
- Immediately below the ingredient list in a 'contains' statement, for example: CONTAINS EGG.<sup>14</sup>

Additionally, a major food allergen may not be omitted from the product label even if it is only an incidental ingredient such as in a spice, flavoring, coloring, additive, or used merely as a processing aid. These regulations only apply to ingredients derived from the eight foods that are considered the major allergens. An individual with allergy to an ingredient not covered under FALCPA, such as garlic or sesame, would still need to call the manufacturer to ascertain if garlic, sesame or sesame oil was included in a vague ingredient term such as 'spice' or 'natural flavoring' of a product.

Manufactured food products, including those imported for sale in the USA, dietary supplements, medical foods and infant formulas are all required to comply with FALCPA.<sup>13</sup> Currently, highly refined vegetable oils derived from major food allergens (including highly refined soy and peanut oils) are not considered allergens by FALCPA because highly refined oils have almost complete removal of allergenic protein and have not been shown to pose a risk to human health.<sup>15</sup> In the USA, soy oil is almost always a highly refined oil, meaning it would not be considered an allergenic ingredient. Peanut oil, on the other hand, may or may not be highly refined. Peanut oil can also be present as expeller-pressed, cold-pressed, expelled or extruded, which may contain enough peanut protein to cause an allergic reaction. As the ingredient list of a finished food will not tell a consumer the nature of the oil ingredient or how the oil was

**TABLE 48-1 Major Allergens by Country or Region**

Country or Countries	USA, Mexico, Hong Kong, China	Australia and New Zealand	Canada	European Union
Allergens requiring full disclosure on package labels based on allergy labeling regulation in specified country	Milk Egg Wheat Soy Peanut Tree nuts Fish Crustacean shellfish	Milk Egg Wheat Soy Peanut Tree nuts Fish Crustacean shellfish Sesame	Milk Egg Wheat Soy Peanut Tree nuts Fish Crustacean shellfish Mollusks Sesame	Milk Egg Wheat Soy Peanut Tree nuts Fish Crustacean shellfish Mollusks Mustard Celery Lupine Sesame All gluten-containing grains

The specific tree nut, fish or shellfish species must be identified.

processed, it will not be possible to tell from a product label if the peanut oil listed is highly refined or otherwise processed. Calling the manufacturer may provide more specific information. However, since peanut oil is infrequently used in manufactured products and the labeling of the oil is not sufficient to determine if the ingredient is safe, avoidance of peanut oil is frequently recommended. Tree nut oils and sesame oil are typically not highly refined and will pose a risk to allergic consumers and therefore should be avoided.<sup>14,15</sup>

The presence of ingredients in manufactured foods due to cross-contact is not required to be listed on product labels. Cross-contact occurs when an 'allergen-safe' food unintentionally comes in contact with an allergen during the use of shared storage, transportation or production equipment or routine methods of growing and harvesting crops. Cross-contact may lead to significant levels of hidden allergens in a product without identification on the product label. Many manufacturers are addressing the issue of cross-contact with precautionary labeling such as: 'May contain [allergen]', 'Manufactured in a facility that also manufactures [allergen]' or 'Manufactured on shared equipment with [allergen]'. Those with food allergies should be aware that these statements are currently voluntary and unregulated. A variety of statements are being employed, some of which provide food allergic consumers with little meaningful information on the potential presence of allergens in pre-packaged foods. For instance, in a 2010 study, product labels stating, 'Good Manufacturing Practices were used to segregate ingredients in a facility that also processes peanut, tree nuts, milk, shellfish, fish, and soy ingredients,' were interpreted to mean that the product was safe for these otherwise undisclosed ingredients; however, milk was detected in two, and egg in one of the three products with this statement.<sup>16</sup> A 2007 study by Hefle and colleagues<sup>17</sup> evaluated 179 products with peanut advisory labeling. Two different lot numbers of each of these 179 products were analyzed for detectable peanut allergen. The results revealed that 7% (13/179) of the products tested contained detectable levels of peanut in one or both lots and the type of advisory statement used did not reflect the degree of risk. Precautionary statements carry a small but real risk to the consumer with food allergies and no one statement represents a greater or lesser degree of risk than another. The FDA is currently working on developing a long-term strategy to assist manufacturers in using allergen precautionary labeling that is truthful and not misleading, conveys a clear and uniform message and adequately informs US consumers of risk. In the USA, the National Institutes of Allergy and Infectious Diseases (NIAID) expert panel guidelines for the diagnosis and management of food allergy suggest advising patients to avoid precautionary-labeled products. However, individual guidance based on clinical assessment may be appropriate.

Although similar legislation exists in many countries, the foods identified as allergens (see Table 48-1) and slight variations of regulations exist. For instance, precautionary statements in Canada must use the wording, 'May Contain —,' to prevent confusion and misinterpretation. Unique to the European Union (EU) food businesses are required to provide allergy information on food sold unpackaged or pre-packed for direct sale (such as in bakeries, delicatessens and caterers).<sup>18</sup> In Australia, a voluntary incident trace allergen labeling (VITAL) system may be used by food producers to provide standardized, consistent precautionary advice to consumers with food allergy.

Although label ambiguities continue to exist, the package label provides information to the consumer about the contents of a product and should be read each and every time a product is purchased. Healthcare professionals must be prepared to offer extensive education to patients with food allergies so that safe food selections can be made.

## DAILY LIVING WITH FOOD ALLERGIES

Once a food item is purchased and brought into the home, that item must continue to be carefully handled to prevent cross-contact with the identified allergen. Storage of ingredients in the home should be planned to prevent cross-contact. A separate shelf in the refrigerator or cupboard may be reserved for the allergen-free foods. Meal preparation to prevent cross-contact in the home is also essential. All food preparation areas, cooking utensils and cooking equipment should be cleansed with warm soapy water and rinsed. Allergen-free foods and meal items can be prepared first, covered, and removed from the area prior to the preparation of other foods for the home. Families will also benefit from guidance on how to prepare meals without their allergenic ingredients.

Families living with food allergies report that avoiding eating in restaurants is the number one cause of decreased quality of life due to the food allergy.<sup>19</sup> Those with food allergies may be especially at risk while dining out since restaurants are not required to list ingredients and the wait staff is generally ignorant about the ingredients in a dish.

Planning ahead and communication with restaurant staff is the first key step in obtaining a safe restaurant meal. Calling ahead to ask how a food allergy is accommodated as well as avoiding the restaurant's busiest hours is often helpful. Families should be taught to inform the staff that their child has a food allergy, not simply to ask if a menu item contains their allergen. 'Chef Cards' provide a written list of ingredients to avoid for specific allergens and are available from organizations such as Food Allergy Research and Education (FARE; [www.foodallergy.org](http://www.foodallergy.org)). In addition to ingredient inquiries, families must learn to inform restaurant staff about cross-contact risk. Cross-contact in a restaurant environment is not uncommon. For example, the same grill might be used to make a cheeseburger that is used for a plain hamburger, or the French fries might have been cooked in the same deep fat fryer as fried shrimp or milk-containing onion rings. The same tongs or mixing bowls may be used to assemble a salad with nuts as are used to assemble a plain green salad. Families should be taught to speak directly to the chef or food service manager to inquire about ingredients and cross-contact risk. It is important to inform the chef that a clean cooking area, cooking equipment and utensils must be used. Ordering single ingredient foods, prepared simply, will decrease the risk of hidden ingredients. When the food arrives at the table, families should confirm with the chef that the meal was prepared correctly and not have their child eat the food if there is any doubt as to the safety of the meal. Lastly, as always, emergency medications should be available when eating at home or away from home.

Certain types of eating establishments will present a greater risk of allergen exposure. For example, cafeterias, buffets and salad bars have inherently greater risk of cross-contact due to spillage and shared serving utensils. Asian and other ethnic restaurants may use more allergenic ingredients (soy, peanuts, tree nuts, fish and shellfish) in a wide variety of dishes and the

cooking equipment is generally not washed between each meal prepared. Ice cream parlors use the same scooper for all flavors of ice cream. Asking for a clean scooper may not eliminate the risk as previous servings with a contaminated scooper into the otherwise safe flavor may have already caused cross-contact. For seafood allergies, seafood restaurants may be problematic even if a non-seafood item is ordered because of the greater risk of cross-contact in the kitchen.<sup>20</sup>

Children with food allergies will attend schools just like their nonallergic peers and some planning ahead will help to make the environment safer. Management issues in schools involve methods to prevent relevant exposure to allergens and plans to recognize and treat allergic reactions and anaphylaxis.<sup>21</sup> Physicians should provide written, easy-to-follow instructions in the form of an emergency care plan (ECP), which includes direction on recognizing and treating an allergic reaction including the medication to be given and the appropriate dosing. Parents will need to provide a copy of the ECP to the school staff and inform teachers, nurses, administrators and food service staff about the food allergy. Families should plan to meet with school personnel prior to the start of the school year. Communication with the school about topics such as classroom parties, transportation, supervision in the lunch room if needed, substitute teacher notification, field trips and after-school programs will help to plan food allergy management in all areas of the school environment. FARE has developed a variety of resources and products including a downloadable ECP for physicians to complete and management tips for classrooms and school cafeterias. The Centers for Disease Control and Prevention has published a document entitled Voluntary Guidelines for Managing Food Allergies in Schools and Early Care and Education Programs, a PDF that can be downloaded directly from their website ([www.cdc.gov/HealthyYouth/foodallergies/pdf/13\\_243135\\_A\\_Food\\_Allergy\\_Web\\_508.pdf](http://www.cdc.gov/HealthyYouth/foodallergies/pdf/13_243135_A_Food_Allergy_Web_508.pdf)) or accessed via the FARE website at [www.foodallergy.org](http://www.foodallergy.org). Parents, physicians, school administrators, teachers, school nurses, food service staff, and childcare and camp staff will find these resources valuable in the planning required to keep children with food allergies safe. Additionally, the Consortium of Food Allergy Research (CoFAR) has developed and validated an extensive food allergy education program that has free and downloadable patient education handouts on specific allergen avoidance diets, fact sheets on specific food allergic disorders, label reading, cross-contact, restaurant meals, cooking without allergens, nutrition and management issues in schools and camps ([www.cofargroup.org](http://www.cofargroup.org)).<sup>22</sup>

## Nutrition

### OVERVIEW

Fundamental to the care of any infant or child, including those with food allergies, is the assessment of nutritional status. Children with food allergies may have inadequate nutrient intake if the elimination diet is not well designed to substitute for nutrients lost to the elimination diet. Additionally, feeding problems such as food aversion and a limited acceptance of a variety of foods are common in children with food allergies and may significantly contribute to poor energy and overall nutrient intake. Certain food allergic disorders such as eosinophilic gastrointestinal disorders are commonly accompanied by poor appetite and early satiety, which may have an impact on overall nutrient intake.<sup>23–25</sup> Numerous studies have demonstrated that

children with food allergies are at risk of inadequate nutritional intake and poor growth.<sup>7,26–30</sup>

A comprehensive baseline nutrition assessment includes gathering, verifying and interpreting data from anthropometric measurements, dietary history, medical history, physical examination and laboratory indices. Additionally, when assessing pediatric nutritional status, eating abilities and competencies must also be determined. Key indicators of potential nutritional risk in children with food allergies are a greater number of eliminated foods or greater nutritional value of eliminated foods, picky or self-selective eating, feeding delays/difficulties, poor variety or volume of foods provided/accepted or an unwillingness of the child to ingest supplemental formula or other substitute foods.<sup>31</sup>

### GROWTH

Several studies have evaluated growth in the pediatric population with food allergy. Christie and colleagues compared height, weight, body mass index and estimates of energy and nutrient intakes in a group of 98 children with food allergy and 99 children without food allergy and found that children with two or more food allergies were shorter, based on height-for-age percentiles than those with no food allergy or only one food allergy.<sup>26</sup> Similarly, Isolauri and colleagues found length and weight-for-length indices in a group of 100 infants with food allergy decreased compared with healthy, age-matched controls.<sup>28</sup> Jensen and colleagues found height for age was significantly reduced in a group of patients living with cow's milk allergy for more than 4 years when compared with height of parents and siblings as well as normal controls.<sup>32</sup> Additionally, it is possible that children with food allergies may have decreased growth despite adequate nutritional intake. Flammarion and colleagues<sup>30</sup> conducted a cross-sectional study comparing children with food allergies ( $N = 96$ ) who had been counseled by a dietitian to paired controls without food allergies ( $N = 95$ ). Children with food allergies had weights and heights within the normal range; however, they were smaller for their age than the nonallergic controls, even when they received similar nutrition. Suboptimal nutrition in this population may exacerbate the risk and decreased growth can more easily become poor growth. So while there may be other contributing factors associated with decreased growth in children with food allergy, in general the primary cause of poor growth likely stems from inadequate substitution in the elimination diet.

The NIAID Food Allergy Guidelines recommend close growth monitoring for all children with food allergies.<sup>12</sup> Review of current and historical growth should be completed according to current standards of care that are based on Centers for Disease Control and Prevention (CDC) and World Health Organization (WHO) or other national standards. Measurements, including weight, length or height, and head circumference as age appropriate, should be obtained and plotted on appropriate growth charts (WHO charts for infants and children from birth to 24 months and CDC charts for children age 2 to 20 years). Growth typically follows predictable increases in length, weight and head circumference and significant changes in growth velocity are not expected. Plotting growth measurements on the appropriate standardized growth chart will allow assessment of growth velocity for that particular child as well as provide a comparison of growth with the reference population.



Weight for length (under 2 years) and body mass index (BMI; 2 years and older), defined as weight in kilograms divided by the square of height in meters, may be helpful as they take into consideration weight for height. The WHO considers less than the 3rd percentile and greater than the 97th percentile to reflect abnormal growth. The CDC defines underweight in children as a BMI of less than the 5th percentile. Children are considered to be overweight when their BMI is greater than the 85th percentile and obese when their BMI is greater than the 95th percentile.

## DIETARY INTAKE ASSESSMENT

Dietary intakes can be obtained by 24-hour recall or multiple-day food diary or food frequency questionnaire. A 24-hour recall is generally useful when assessing intake in an infant who is predominantly breastfed or bottle-fed but may provide limited information for older children, as accuracy of a mixed diet may not be reflected with recall. For older infants and children, a food diary will provide a more accurate estimate of intake. A food diary of at least three days (including one weekend and two weekdays) should include the amount and types of foods ingested and the timing of meals and snacks. Questions about typical dietary patterns or food frequency questionnaires may also be used and are especially useful in assessing specific nutrient intakes. For example, assessment of calcium and vitamin D intake may be determined by asking about frequency and amounts of dairy or enriched dairy substitutes consumed.

A registered dietitian will be able to compare dietary patterns to recommendations from the Dietary Reference Intakes (DRI; <http://fnic.nal.usda.gov/dietary-guidance/dietary-reference-intakes>) or food group guides specified by the US Department of Agriculture ([www.choosemyplate.gov](http://www.choosemyplate.gov)) or provided by governmental agencies in other countries. The DRI and other guidelines may be used as a tool to assess nutrient intake, plan interventions and/or monitor the patient's ongoing nutrient intakes.<sup>33</sup> Even clinicians who are not trained to assess nutrient intake may glean valuable information from a food diary or food frequency questionnaires. For instance, unusual meal or snack patterns such as feeding on demand beyond infancy, or unusual food intakes such as excessive fruit juice consumption may become apparent and give clues to potential causes of poor growth or nutritional status in a child.

## EATING COMPETENCE

Eating competence describes a child's ability to eat and enjoy a wide variety of foods of varying flavors and textures that will support adequate nutrition for growth and development. Eating competence and pediatric nutrition are often discussed side by side because feeding problems are common in childhood, with an estimated 25% to 35% of otherwise healthy children affected.<sup>34</sup> Eating is a complex, learned process involving the acquisition of physical skills, behaviors, acquired tastes, and attitudes and feelings about eating in general as well as about particular food items.<sup>35,36</sup> Even mild, self-selective or 'picky' eating can impact nutrient intake and, in combination with an allergen elimination diet, can have serious nutritional implications. Assessment of eating competencies will provide the information needed to provide an effective nutrition care plan. See Chapter 42 for more information on management of feeding problems.

## ESTIMATING NUTRITIONAL NEEDS

### Energy

The estimated energy requirement (EER) is the average dietary energy intake that is predicted to maintain energy balance. For children, the EER includes the needs associated with the deposition of tissues at rates consistent with good health. There is no established recommended dietary allowance (RDA) for energy because energy intakes exceeding the EER would be expected to result in excessive weight gain. EER can be calculated using the equations provided in the DRI reports ([www.nap.edu](http://www.nap.edu)) or by using the interactive DRI calculator for healthcare professionals available on the USDA website (<http://fnic.nal.usda.gov/fnic/interactiveDRI/>). Energy is provided in the pediatric diet through three major classes of macronutrients: proteins, carbohydrates and fats.

**Protein.** Adequate protein in the diet is crucial in all age groups. Many excellent sources of protein are also common allergens including milk, egg, soy, fish, shellfish, peanut and tree nuts. Diets must be carefully planned to meet protein needs when high quality protein sources are eliminated from the diet. Inadequate dietary protein intake may be a contributing factor in the decreased stature reportedly seen in the population of children with food allergies.

Protein needs may be estimated using the DRI for protein found in [Table 48-2](#).<sup>37</sup> An estimated 65% to 70% of protein needs should come from sources of high biologic value, meaning animal products for the most part, which contain a full complement of indispensable amino acids. Animal products (milk, eggs, meat, fish and poultry) are not necessary to provide optimal protein, but most alternative sources from plants, legumes, grains, nuts, seeds and vegetables do not contain a full complement of indispensable amino acids and therefore greater dietary planning will be required. Additionally, dietary protein recommendations are based on the assumption that energy intake is adequate. If energy intake is insufficient, free amino acids will be oxidized for energy, allowing for less available amino acids for anabolic and synthetic pathways.<sup>37</sup>

**Fat.** Adequate dietary fat is crucial as fats are an important source of concentrated energy, support the transport of fat-soluble vitamins and provide the two fatty acids – omega 3, alpha-linolenic acid (ALA) and omega 6, linoleic acid (LA) – which are essential in the human diet. Dietary fat needs may be estimated using the DRI for fats in [Table 48-2](#).<sup>37</sup> Adequate dietary fat is an especially important source of energy and nutrients for rapidly growing infants and toddlers. Dietary fat intakes below 22% of total caloric intake increase risk of energy, vitamin E and essential fatty acid deficiency. Dietary fat is present in a wide variety of foods, such as dairy products, eggs, meat, fish and poultry, vegetable oils and margarines and many manufactured and processed snack foods, convenience meals and desserts. Children on allergen-restricted diets, who must eliminate not only the allergen but also many processed and manufactured foods, may find it especially difficult to meet dietary fat needs without adding supplemental fats (in the form of vegetable oils) to the diet.

**Carbohydrates.** Carbohydrates make up the remaining energy sources and provide an important supply of numerous vitamins, minerals and trace elements. Carbohydrates should

**TABLE 48-2** Dietary Reference Intakes for Macronutrients for Children

Nutrient	Age	RDA*/AI g/day (Unless Otherwise Specified)	AMDR % of Total Energy Intake
Protein	0–12/mo	1.5/g/kg/day	ND
	1–3/yr	1.1*/g/kg/day	5–20
	4–13/yr	0.95*/g/kg/day	10–30
	14–18/yr	0.85*/g/kg/day	10–30
Carbohydrates	0–6/mo	60	ND
	7–12/mo	95	ND
	1–18/yr	130*	45–65
Total fat	0–6/mo	31	ND
	7–12/mo	30	ND
	1–3/yr		30–40
	4–18/yr		25–35
n-3 Fatty acids	0–6/mo	0.5	ND
	7–12/mo	0.5	ND
	1–3/yr	0.7	0.6–1.2
	4–8/yr	0.90	0.6–1.2
	Males		
	9–13/yr	1.2	0.6–1.2
	14–18/yr	1.6	0.6–1.2
	Females		
	9–13/yr	1.0	0.6–1.2
	14–18/yr	1.1	0.6–1.2
n-6 Fatty acids	0–6/mo	4.4	ND
	7–12/mo	4.6	ND
	1–3/yr	7	5–10
	4–8/yr	10	5–10
	Males		
	9–13/yr	12	5–10
	14–18/yr	16	5–10
	Females		
	9–13/yr	10	5–10
	14–18/yr	11	5–10

Adapted from the DRI report: *Dietary Reference Intakes for Energy, Carbohydrate, Fiber, Fat, Fatty Acids, Cholesterol, Protein, Amino Acids (2002/2006)*. Available at: [www.nap.edu](http://www.nap.edu).

AI – adequate intake is the recommended average daily intake level based on observed or experimentally determined approximations or estimates of nutrient intake by a group (or groups) of apparently healthy people that are assumed to be adequate. The AI is used when an RDA cannot be determined.

AMDR – acceptable macronutrient distribution range is the range of intake for an energy source that is associated with reduced risk of chronic disease while providing adequate intakes of essential nutrients.

ND – not determinable.

\*RDA – recommended dietary allowances are set to meet the needs of almost all individuals in a group.

comprise between 45% and 65% of total caloric intake. Grains, dairy products, legumes, fruits and vegetables provide dietary carbohydrates. Simple sugars and foods with added sugars also contribute carbohydrates and additional energy, but are of little further nutritional benefit and should be limited to no more than 25% of total energy intake. Dietary carbohydrates are an important source of iron, thiamin, niacin, riboflavin and folic acid. Children on wheat avoidance diets should substitute alternative grains to meet the recommended dietary allowance (RDA) for carbohydrate of 130 g/day for adults and children 1 year of age or older.

Macronutrient intake should be considered in the nutritional assessment and modifications made to ensure an appro-

priate nutritional balance. Meeting the recommended dietary intakes of macronutrients can often be challenging when food groups are eliminated due to food allergies. Acceptable macronutrient distribution ranges (AMDR) have also been established for protein, carbohydrates and fats and indicate the range of intake for a particular energy source, expressed as a percentage of total caloric intake that is associated with reduced risk of chronic disease, while providing adequate intakes of essential nutrients.<sup>37</sup> The AMDR may be found in [Table 48-2](#) and can be used to guide the appropriate intake and distribution of carbohydrates, fats and proteins.

### Micronutrients

Variety in the diet contributes to adequacy of nutrients provided. When a food group is eliminated, the nutrients provided by that food group must be provided by other dietary sources. In 2002, Christie and colleagues<sup>36</sup> found that children with multiple food allergies or cow's milk allergy consumed less dietary calcium than age-specific recommendations compared with children without cow's milk allergy and/or one food allergy. Henricksen and colleagues<sup>27</sup> surveyed a sample of families with young children with milk allergy and/or egg allergy and assessed dietary intake using a complete 4-day, weighed recording. Children on milk-free diets had significantly lower intake of energy, fat, protein, calcium, riboflavin and niacin.

While it is important to ensure adequate intake of all essential nutrients, certain nutrients will be at greater risk of insufficiency depending on the food allergen and must be adequately replaced by other foods in the diet. When foods are chosen carefully, and appropriate substitutions are made, the diet for a child with food allergies can be nutritionally adequate. When dietary modifications are inadequate to meet vitamin, mineral and trace element needs, appropriate supplementation may be considered. Dietary supplements, however, may pose a risk of contamination with food allergens and they should be chosen carefully, with consideration for safe ingredients as well as risk assessment of potential cross-contact during manufacturing.

## Common Allergen Elimination Diets of Early Childhood

The prevalence of food allergy in infants and young children is approaching 8%<sup>38</sup> with the major allergens of early childhood being milk, egg, soy, peanut and wheat.

### COW'S MILK ALLERGY

Cow's milk allergy (CMA) affects predominantly the pediatric population, as approximately 80% of children with CMA eventually develop clinical tolerance. Recent epidemiologic studies indicate that milk allergy may be more persistent with fewer children becoming tolerant to milk in the first few years of life. One large retrospective study from a specialty clinic reported resolution rates in 807 children with CMA and found the rates of resolution were 19% at the age of 4 years, 42% by 8 years, 64% by 12 years, and 79% by 16 years.<sup>39</sup> In a recent observational cohort of 244 infants with CMA, 52.5% of patients had resolution of milk allergy at a median age of 62 months and a median age of last follow-up at 66 months.<sup>40</sup> These studies indicate that children with CMA may be required to eliminate

milk, a nutrient-dense food source, for longer durations throughout childhood.

The nutritional effect of cow's milk elimination in the pediatric population is great because milk is not only a good source of fat, protein, calcium and vitamin D but is also the primary source for most young children. Milk also provides vitamin B<sub>12</sub>, vitamin A, pantothenic acid, riboflavin and phosphorus. Finding a nutritionally dense substitute for cow's milk in the pediatric diet is essential and parents of children with CMA require detailed advice about nutritionally sound food choices.

In 2010, the World Allergy Organization (WAO) Diagnosis and Rationale for Action against Cow's Milk Allergy (DRACMA) guidelines provided recommendations for the treatment of cow's milk allergy (CMA).<sup>41</sup> Specific guidance was provided on how long an infant should maintain a substitute milk and what kind of substitute milk is appropriate based on the symptom or food allergic disorder. DRACMA recommends a cow's milk substitute of adequate nutritional value for infants and young toddlers until 2 years of age. Adequate substitutes are identified as either breast milk (with maternal milk avoidance and calcium supplementation) or a substitute formula, which can be either extensively hydrolyzed or amino acid based in early infancy. Soy formula is not recommended for pre-term infants and has no benefit over hypoallergenic formula in CMA.<sup>41,42</sup> The type of formula recommended may vary based on the age and nutritional needs of the patient, the type of food allergic disorder and the degree of severity of the presenting symptoms. See Table 48-3 for substitute pediatric formula recommendations based on DRACMA guidelines.

Transitioning an infant from a complete formula to a milk product is typically considered around 1 year of age or, ideally, when at least two thirds of the total daily caloric intake comes from a varied solid food diet since a wide variety of foods is more likely to contribute to micronutrient adequacy. However, other criteria for the infant with CMA must be considered as the milk elimination diet may not be nutritionally equivalent to the diet that is not restricted. Additionally, the enriched alternative beverage (soy, tree nut, seed or grain-based 'milks') may not provide comparable nutrition. Alternative mammalian milks, such as goat's or sheep's milk, are also not suitable due to homologous proteins and the strong risk of cross-reactivity.<sup>43</sup>

For children with concomitant milk and soy allergy, enriched rice, coconut and almond milks may provide a good source of

calcium and vitamin D, but they provide essentially no protein and are low in fat. Therefore, protein requirements will need to be met entirely through the solid food diet before switching to these enriched 'milk' beverages. Fat intake will also need to be assessed and additional fat in the form of vegetable oils may be required. Christie and colleagues showed that the risk of consuming inadequate intakes of calcium and vitamin D among children with CMA was decreased if a safe enriched soymilk or commercially prepared infant/toddler formula was provided, suggesting that children with milk allergy should continue to include an adequate, nutrient-dense milk substitute in the diet.<sup>26</sup> It is often the case that a 1-year-old child is not capable of meeting protein and fat needs exclusively through the solid food diet, therefore maintaining the child on a hypoallergenic commercial formula, as recommended in DRACMA guidelines, certainly may be warranted.<sup>41</sup>

The nutritional impact of milk allergy is great because milk is an excellent source of protein, calcium, vitamin D, phosphorus, vitamin A, vitamin B<sub>12</sub> and riboflavin. Possible alternative dietary sources for these nutrients can be found in Table 48-4.

## EGG ALLERGY

Eggs contribute protein, vitamin B<sub>12</sub>, riboflavin, pantothenic acid, biotin and selenium in the diet. Many foods supply the nutrients found in eggs. Egg in the diet does not usually account for a large proportion of daily dietary intake and therefore the nutrients lost through egg avoidance are not significant if the allergy stands alone and the diet is otherwise varied.

Egg is a common ingredient in many recipes such as baked goods, casseroles and meat-based dishes such as meatballs, meatloaf and breaded meats. Learning to replace egg in the diet will help families to continue to enjoy traditional foods. Many commercial egg substitutes actually contain egg protein and therefore are not suitable for those with egg allergy, although egg-free replacers for baking are available. A free downloadable cooking handout from the CoFAR food allergy education program ([www.cofargroup.org](http://www.cofargroup.org)) will help families learn how to substitute for egg in their favorite recipes.

## BAKED MILK AND EGG TOLERANCE

We now know that as many as 70% of patients with milk and egg allergy tolerate extensively heated (baked) milk and egg

**TABLE 48-3 Pediatric Formula Recommendations Based on DRACMA Guidelines**

Food Allergy Symptom or Disorder	First Formula Recommendation	Second Formula Recommendation	Third Formula Recommendation
IgE-mediated allergy Low risk anaphylaxis	Extensively hydrolyzed formula	Amino acid based formula	Soy formula
IgE-mediated allergy High risk anaphylaxis	Amino acid based formula	Extensively hydrolyzed formula	Soy formula
Food protein-induced enterocolitis (FPIES) or proctitis/proctocolitis	Extensively hydrolyzed formula	Amino acid based formula	–
Eosinophilic esophagitis	Amino acid based formula	–	–
Heiner syndrome	Amino acid based formula	Extensively hydrolyzed formula	Soy formula

\*Diagnosis and Rationale for Action Against Cow's Milk Allergy.<sup>41</sup>

**TABLE 48-4** Nutrients Provided by Milk and Milk Products and Alternative Dietary Sources

Nutrients in Cow's Milk	Alternative Sources
<b>MACRONUTRIENTS</b>	
Dietary protein	Commercial formula, meat, fish, poultry, egg, soybean or enriched soy beverage, peanut, other legumes, tree nuts
Dietary fat	Commercial formula, vegetable oils, milk-free margarine, avocado, meats, fish, poultry, peanut, tree nuts, seeds
<b>MICRONUTRIENTS</b>	
Calcium	Commercial formula, enriched alternative 'milk' beverage (soy, rice, almond, coconut, oat, potato), calcium fortified tofu, calcium fortified juice
Vitamin D	Commercial formula, enriched alternative 'milk' beverage, fortified milk-free margarine, fortified eggs, liver, fish liver oils, fatty fish
Vitamin A	Retinol: Liver, egg yolk, fortified milk-free margarine Carotene: Dark green leafy vegetables, deep orange fruits and vegetables (broccoli, spinach, carrots, sweet potatoes, pumpkin, apricot, peach, cantaloupe), enriched alternative 'milk' beverage
Pantothenic acid	Meats, vegetables (broccoli, sweet potato, potato, tomato products), egg yolk, whole grains, legumes
Riboflavin	Dark green leafy vegetables, enriched and whole grain products
Vitamin B <sub>12</sub>	Meat, fish, poultry, egg, enriched alternative 'milk' beverage, fortified cereals, nutritional yeast

ingredients.<sup>44,45</sup> Heating milk and egg ingredients generally decreases protein allergenicity by destroying conformational epitopes. The introduction of extensively heated milk and egg to the diet of those who tolerate baked milk and egg ingredients can improve the nutritional quality of the diet and decrease the strain and burden of strict avoidance, and importantly, appears to represent an alternative approach to oral immunomodulation. Nowak-Wegrzyn et al<sup>44</sup> introduced baked milk into the diets of children who were baked milk tolerant yet reactive to unheated milk. Children who incorporated baked milk into the diet were 16 times more likely to become tolerant to unheated milk compared to a comparison group of children ( $P < .001$ ) who continued strict avoidance of milk ingredients.<sup>45</sup> Children who incorporated baked egg into the diet were 14.6 times more likely than children in the comparison group ( $P < .0001$ ) to develop regular egg tolerance, and they developed tolerance earlier (median 50.0 vs 78.7 months;  $P < .0001$ ).<sup>46</sup>

Although the patients who tolerate baked egg and milk ingredients can have a more liberalized diet, there are additional complexities in avoidance. For instance, a cake may have baked milk or egg ingredients in the cake and unbaked ingredients in the frosting or filling. Flavorings on crackers or chips may be topically applied after the item is baked. Other products such

as quiche may have too much milk or egg protein to be tolerated. A general guideline is to allow only the amount of baked ingredient to which the patient has been shown to be tolerant (based on physician-supervised oral food challenge) and to avoid commercial products with baked egg or milk listed as the first or second ingredient. Generally, commercial products such as plain cookies or breads that carry a precautionary statement do not need to be avoided but a soy yogurt or vegan cheese for instance may carry the risk of cross-contact with a fresh milk ingredient, so caution is still warranted.

## WHEAT ALLERGY

The child with wheat allergy must avoid all wheat-containing foods, resulting in the elimination of many processed and manufactured products, including bread, cereal, pasta, crackers, cookies and cakes. Wheat is also commonly used as a minor ingredient in other commercial food products such as condiments and marinades, cold cuts, soups, soy sauce, some low or non-fat products, hard candies, licorice and jelly beans. Wheat contributes carbohydrates as well as many micronutrients such as thiamin, niacin, riboflavin, iron and folic acid. Whole grain wheat products also contribute fiber to the diet. Alternative dietary sources of these nutrients should be provided. Four servings of wheat-based products, such as whole grain and enriched cereals or breads, generally provide greater than 50% of the RDA/AI for carbohydrate, iron, thiamin, riboflavin and niacin for children 1 year of age and older, as well as a significant source of vitamin B<sub>6</sub> and magnesium. Elimination of wheat products from the diet has great nutritional impact when nutrient-dense alternatives are not provided. Alternative sources for the nutrients found in wheat can be found in Table 48-5.

Many alternative flours are available to patients with wheat allergy, including rice, corn, oat, arrowroot, potato, sorghum, soy, barley, buckwheat, rye, amaranth, millet, teff and quinoa. It has been reported that 20% of individuals with one grain allergy may be clinically reactive to another grain, therefore use of alternative grains should be individualized and based on tolerance as determined by the patient's allergist.<sup>47</sup> Alternative flours (grain, vegetable, legume, seed or nut) may improve the nutritional quality, variety and convenience of the wheat-restricted diet. Many of these flours are commercially available for home use and there is also a broad array of gluten-free products available that may be suitable for the patient with wheat allergy. Choosing those made from enriched or whole grains will improve the nutritional quality of the diet.

## SOYBEAN ALLERGY

Soybean/soy protein is an ingredient in a surprising variety of manufactured products. Eliminating many manufactured foods with soy as an ingredient will have an impact on the variety of manufactured products available to those with soy allergy. Highly refined soybean oil is a soy ingredient that is not considered an allergen and does not require labeling as such.<sup>48</sup> Studies show that the vast majority of soy-allergic individuals can also tolerate soy lecithin although soy lecithin must be labeled as an allergen.<sup>15</sup> Products containing soy lecithin, with a 'Contains soy' statement, may in fact be safe for consumption by most patients with soy allergy. Families should never assume



**TABLE 48-5** Nutrients Provided by Wheat and Alternative Dietary Sources

Nutrients Provided by Wheat	Alternative Dietary Sources
<b>MACRONUTRIENTS</b>	
Carbohydrates	Products made with alternative grains: amaranth, buckwheat, corn, millet, oat, rice, sorghum, teff, quinoa; fruits, vegetables, legumes
Fiber	Fruits, vegetables, alternative whole grain products, legumes
<b>MICRONUTRIENTS</b>	
Thiamin	Enriched and whole alternative grain products, nuts, legumes, liver, pork, sunflower seeds
Riboflavin	Enriched and whole alternative grain products, milk, dark green leafy vegetables
Niacin	Enriched and whole alternative grain products, meat, fish, poultry, liver, peanuts, sunflower seed, legumes
Folic acid	Enriched and whole alternative grain products, beef liver, dark green leafy vegetables, legumes, seeds
Iron	Heme iron: Meat, liver, fish, shellfish, poultry Non-heme iron: Enriched and whole alternative grain products, legumes and dried fruits

that a product is safe without first calling the manufacturer to determine if any soy ingredient other than soy lecithin is contained in the product.

While soy itself is a nutritionally dense food, it generally is not a major component of the diet, and therefore the nutrients lost due to soy elimination may easily be replaced. If there are other food allergies or dietary patterns such as a vegetarian diet, then the child with soy allergy may be at nutritional risk.

## PEANUT ALLERGY

Peanut allergy affects approximately 1.8% of children in the USA.<sup>38</sup> Avoidance of peanuts in the diet does not necessarily pose any specific nutritional risk when there are no other nutritional risk factors.

Approximately 20% of young children with peanut allergy may eventually develop clinical tolerance. Children with peanut allergy are at greater risk for tree nut allergies. In fact, about 35% of those allergic to peanut will react to at least one tree nut although these two foods are botanically different, peanut being a legume rather than a nut.<sup>47</sup> Cross-reactivity between peanuts and legumes is rare with only about 5% of those with a peanut allergy reacting to another legume.<sup>47</sup> However the legume lupine (lupin) appears to carry a greater risk of cross-reactivity with peanut. In recognition of the risk of cross-reactivity with peanut as well as the risk of having a primary allergy to lupine, the EU has included lupine as a major allergen, with products containing lupine or its derivatives requiring full disclosure on

EU product labels.<sup>49</sup> Lupine is not, however, considered a major allergen in the USA, Canada or Australia.<sup>48</sup>

## Oral Food Challenges

A child with food allergies may undergo an oral food challenge to identify or confirm immediate and occasionally delayed food allergic reactions or to determine if clinical tolerance to a particular food has been acquired. The individual patient history and the results of prick skin tests and food-specific serum IgE values will determine if an oral food challenge is appropriate. The type of challenge is determined by the history, the age of the patient and the likelihood of encountering subjective reactions. The food challenge requires evaluation of the patient prior to the procedure and preparation of the office for the organized conduct of the challenge, for a careful assessment of the symptoms and signs and the treatment of reactions.

During the physician-supervised oral food challenge, the challenge food is administered gradually in incremental doses.<sup>50</sup> The patient is observed for symptoms during the procedure and for a period of time after the full test dose is administered. Challenges can be open, single-blind or double-blind. While the utility of the double-blind, placebo-controlled food challenge (DBPCFC) as the 'gold standard' for food allergy testing is acknowledged, the NIAID Food Allergy Guidelines noted that open or single-blind challenges could also be acceptable for food allergy evaluation when the challenge outcome is negative or when objective symptoms are elicited that recapitulate the reaction history.<sup>12</sup> Regardless of the type of food challenge, emergency medications should be available and an emergency treatment protocol should be in place.

There are a number of primary documents available to the practicing allergist/immunologist to guide the administration of the physician-supervised oral food challenge.<sup>50,51</sup> In 2012, the American Academy of Allergy, Asthma and Immunology (AAAAI) and the European Academy of Allergy and Clinical Immunology (EAACI) jointly published a consensus report on standardizing the DBPCFC, which is part of the PRACTALL initiative.<sup>50</sup> The Adverse Reactions to Foods Committee of the AAAAI published a work group report on oral food challenge testing, which is a comprehensive guide on conducting physician-supervised oral food challenges.<sup>51</sup> These documents offer in-depth, practical guidance and should be utilized by practicing allergists/immunologists to ensure that safe and scientifically sound challenge procedures are conducted.

## Conclusions

Current management of food allergy entails dietary avoidance of the identified allergen, requiring extensive education (Box 48-2). Allergen elimination diets should not be prescribed lightly and the global impact of these diets should be considered. In theory, elimination of dietary allergens may seem an easy enough task, but avoidance issues are complex and accidental ingestions are not uncommon. Hence, food allergy management must also include comprehensive education on how to recognize and treat a food-allergic reaction. This topic is discussed fully in Chapter 58.

The complete reference list can be found on the companion Expert Consult website at <http://www.expertconsult.inking.com>.

**BOX 48-2 KEY FOOD ALLERGY MANAGEMENT POINTS**

- Avoidance of the identified allergen is key in the management of food allergies. Provide comprehensive education on the scope of allergen elimination issues such as label reading, avoiding hidden sources of the allergen and cross-contact risk. Allergen avoidance sheets are an excellent resource to begin educating families about allergen elimination.
- Provide education to help families manage daily living activities such as going to school or camp, eating in restaurants or friends' homes, shopping and cooking. The goal of education is to reduce the risk of accidental allergen exposure while empowering the family, and eventually the child, to participate in all daily living activities while avoiding the food to which they are allergic. Visit [www.cofargroup.org](http://www.cofargroup.org) for free patient handouts on many issues of food allergy management.
- Ensure that a nutrient-dense alternative food source is recommended to substitute for the nutrients lost to the elimination diet. Follow-up to ensure that the alternative food has been accepted and incorporated into the diet is essential.
- Encourage the family to offer a variety of developmentally appropriate allergen-free foods of varying tastes and textures to help the child develop eating competence and allow even a food elimination diet, with appropriate substitutions, to provide adequate nutrition.
- Use of a milk substitute such as breast milk or a commercially available, hypoallergenic formula may be warranted until 2 years of age in children with milk allergy.
- All children with food allergies should receive nutrition counseling and close growth monitoring as they are at risk of inadequate nutrient intake and poor growth.
- Educate the family on how to recognize and treat a food-allergic reaction.
- Recommend that children with food allergy wear medical alert jewelry.
- Instruct families to have their child's epinephrine autoinjector device immediately available at all times.
- Instruct families to seek medical help immediately by calling 9-1-1 or getting transportation to an emergency room if their child experiences a food-allergic reaction, even if epinephrine has already been given.

**KEY REFERENCES**

- Panel NI-SE, Boyce JA, Assa'ad A, Burks AW, Jones SM, Sampson HA, et al. Guidelines for the diagnosis and management of food allergy in the United States: report of the NIAID-sponsored expert panel. *J Allergy Clin Immunol* 2010;126:S1–58.
- Christie L, Hine RJ, Parker JG, Burks W. Food allergies in children affect nutrient intake and growth. *J Am Diet Assoc* 2002;102:1648–51.
- Groetch M, Henry M, Feuling MB, Kim J. Guidance for the nutrition management of gastrointestinal allergy in pediatrics. *J Allergy Clin Immunol Pract* 2013;1:323–31.
- Sicherer SH, Sampson HA. Food allergy: Epidemiology, pathogenesis, diagnosis, and treatment. *J Allergy Clin Immunol* 2014;133:291–307, quiz 8.
- Fiocchi A, Brozek J, Schunemann H, Bahna SL, von Berg A, Beyer K, et al. World Allergy Organization (WAO) Diagnosis and Rationale for Action against Cow's Milk Allergy (DRACMA) Guidelines. *Pediatr Allergy Immunol* 2010; 21(Suppl. 21):1–125.
- Nowak-Węgrzyn A, Bloom KA, Sicherer SH, Shreffler WG, Noone S, Wanich N, et al. Tolerance to extensively heated milk in children with cow's milk allergy. *J Allergy Clin Immunol* 2008;122:342–7, 347 e1–2.
- Leonard SA, Sampson HA, Sicherer SH, Noone S, Moshier EL, Godbold J, et al. Dietary baked egg accelerates resolution of egg allergy in children. *J Allergy Clin Immunol* 2012;130:473–80 e1.
- Groetch M, Nowak-Węgrzyn A. Practical approach to nutrition and dietary intervention in pediatric food allergy. *Pediatr Allergy Immunol* 2013;24:212–21.
- Sampson HA, Gerth van Wijk R, Bindslev-Jensen C, Sicherer S, Teuber SS, Burks AW, et al. Standardizing double-blind, placebo-controlled oral food challenges: American Academy of Allergy, Asthma & Immunology-European Academy of Allergy and Clinical Immunology PRACTALL consensus report. *J Allergy Clin Immunol* 2012;130:1260–74.
- Nowak-Węgrzyn A, Assa'ad AH, Bahna SL, Bock SA, Sicherer SH, Teuber SS, et al. Work Group report: oral food challenge testing. *J Allergy Clin Immunol* 2009;123(Suppl. 6):S365–83.

## REFERENCES

- Nowak-Węgrzyn A. Future therapies for food allergy. *Przegl Lek* 2013;70:1065–70.
- Nowak-Węgrzyn A. Immunotherapy for food allergy. *Inflamm Allergy Drug Targets* 2006;5: 23–34.
- Wood RA, Sampson HA. Oral immunotherapy for the treatment of peanut allergy: is it ready for prime time? *J Allergy Clin Immunol Pract* 2014;2:97–8.
- Wang J, Sampson HA. Oral and sublingual immunotherapy for food allergy. *Asian Pac J Allergy Immunol* 2013;31:198–209.
- Patel DA, Holdford DA, Edwards E, Carroll NV. Estimating the economic burden of food-induced allergic reactions and anaphylaxis in the United States. *J Allergy Clin Immunol* 2011; 128:110–5 e5.
- Lieberman JA, Sicherer SH. Quality of life in food allergy. *Curr Opin Allergy Clin Immunol* 2011;11:236–42.
- Mehta H, Groetch M, Wang J. Growth and nutritional concerns in children with food allergy. *Curr Opin Allergy Clin Immunol* 2013; 13:275–9.
- Berenson G, Srinivasan S, Chen W, Li S, Patel D for the Bogalusa Heart Study Group. Racial (black-white) contrasts of risk for hypertensive disease in youth have implications for preventive care: the Bogalusa Heart Study. *Ethn Dis* 2006;16(3 Suppl. 4):S4–2–9.
- Gupta R, Holdford D, Bilaver L, Dyer A, Holl JL, Meltzer D. The economic impact of childhood food allergy in the United States. *JAMA Pediatr* 2013;167:1026–31.
- Shemesh E, Annunziato RA, Ambrose MA, Ravid NL, Mullarkey C, Rubes M, et al. Child and parental reports of bullying in a consecutive sample of children with food allergy. *Pediatrics* 2013;131:e10–17.
- Carvalho NF, Kenney RD, Carrington PH, Hall DE. Severe nutritional deficiencies in toddlers resulting from health food milk alternatives. *Pediatrics* 2001;107:E46.
- Panel NI-SE, Boyce JA, Assa'ad A, Burks AW, Jones SM, Sampson HA, et al. Guidelines for the diagnosis and management of food allergy in the United States: report of the NIAID-sponsored expert panel. *J Allergy Clin Immunol* 2010;126:S1–58.
- FDA. <http://www.fda.gov/Food/GuidanceRegulation/GuidanceDocumentsRegulatoryInformation/Allergens/> 2014.
- Taylor SL, Hefle SL. Food allergen labeling in the USA and Europe. *Curr Opin Allergy Clin Immunol* 2006;6:186–90.
- Crevel RW, Kerkhoff MA, Koning MM. Allergenicity of refined vegetable oils. *Food Chem Toxicol* 2000;38:385–93.
- Ford LS, Taylor SL, Pacenza R, Niemann LM, Lambrecht DM, Sicherer SH. Food allergen advisory labeling and product contamination with egg, milk, and peanut. *J Allergy Clin Immunol* 2010;126:384–5.
- Hefle SL, Furlong TJ, Niemann L, Lemon-Mule H, Sicherer S, Taylor SL. Consumer attitudes and risks associated with packaged foods having advisory labeling regarding the presence of peanuts. *J Allergy Clin Immunol* 2007;120: 171–6.
- Food Standards Agency. Food Allergen Labeling. 2014. <http://www.food.gov.uk/business>
- industry/allergy-guide. Last accessed January 13, 2014.
- Cohen BL, Noone S, Munoz-Furlong A, Sicherer SH. Development of a questionnaire to measure quality of life in families with a child with food allergy. *J Allergy Clin Immunol* 2004; 114:1159–63.
- Furlong TJ, DeSimone J, Sicherer SH. Peanut and tree nut allergic reactions in restaurants and other food establishments. *J Allergy Clin Immunol* 2001;108:867–70.
- Young MC, Munoz-Furlong A, Sicherer SH. Management of food allergies in schools: a perspective for allergists. *J Allergy Clin Immunol* 2009;124:175–82, 182 e1–4; quiz 83–4.
- Sicherer SH, Vargas PA, Groetch ME, Christie L, Carlisle SK, Noone S, et al. Development and validation of educational materials for food allergy. *J Pediatr* 2012;160:651–6.
- Haas AM, Maune NC. Clinical presentation of feeding dysfunction in children with eosinophilic gastrointestinal disease. *Immunol Allergy Clin North Am* 2009;29:65–75.
- Mukkada VA, Haas A, Maune NC, Capocelli KE, Henry M, Gilman N, et al. Feeding dysfunction in children with eosinophilic gastrointestinal diseases. *Pediatrics* 2010;126:E672–7.
- Penttiuk SP, Miller CK, Kaul A. Eosinophilic esophagitis in infants and toddlers. *Dysphagia* 2007;22:44–8.
- Christie L, Hine RJ, Parker JG, Burks W. Food allergies in children affect nutrient intake and growth. *J Am Diet Assoc* 2002;102:1648–51.
- Henriksen C, Eggesbo M, Halvorsen R, Botten G. Nutrient intake among two-year-old children on cows' milk-restricted diets. *Acta Paediatr* 2000;89:272–8.
- Isolauri E, Sutas Y, Salo MK, Isosomppi R, Kaila M. Elimination diet in cow's milk allergy: risk for impaired growth in young children. *J Pediatr* 1998;132:1004–9.
- Kim J, Kwon J, Noh G, Lee SS. The effects of elimination diet on nutritional status in subjects with atopic dermatitis. *Nutr Res Pract* 2013;7: 488–94.
- Flammarion S, Santos C, Guimber D, Jouannic L, Thumerelle C, Gottrand F, et al. Diet and nutritional status of children with food allergies. *Pediatr Allergy Immunol* 2011;22: 161–5.
- Groetch M, Henry M, Feuling MB, Kim J. Guidance for the nutrition management of gastrointestinal allergy in pediatrics. *J Allergy Clin Immunol Pract* 2013;1:323–31.
- Jensen VB, Jorgensen IM, Rasmussen KB, Mølgård C, Prah P. Bone mineral status in children with cow milk allergy. *Pediatr Allergy Immunol* 2004;15:562–5.
- Trumbo PR, Barr SI, Murphy SP, Yates AA. Dietary reference intakes: cases of appropriate and inappropriate uses. *Nutr Rev* 2013;71: 657–64.
- Fishbein M, Cox S, Swenny C, Mogren C, Walbert L, Fraker C. Food chaining: a systematic approach for the treatment of children with feeding aversion. *Nutr Clin Pract* 2006;21: 182–4.
- Satter E. Eating competence: definition and evidence for the Satter Eating Competence model. *J Nutr Educ Behav* 2007;39(Suppl. 5): S142–53.
- Bernard-Bonnin AC. Feeding problems of infants and toddlers. *Can Fam Physician* 2006; 52:1247–51.
- Trumbo P, Schlicker S, Yates AA, Poos M. Food, Nutrition Board of the Institute of Medicine of the National Academies. Dietary reference intakes for energy, carbohydrate, fiber, fat, fatty acids, cholesterol, protein and amino acids. *J Am Diet Assoc* 2002;102:1621–30.
- Sicherer SH, Sampson HA. Food allergy: Epidemiology, pathogenesis, diagnosis, and treatment. *J Allergy Clin Immunol* 2014;133: 291–307, quiz 8.
- Skripak JM, Matsui EC, Mudd K, Wood RA. The natural history of IgE-mediated cow's milk allergy. *J Allergy Clin Immunol* 2007;120: 1172–7.
- Wood RA, Sicherer SH, Vickery BP, Jones SM, Liu AH, Fleischer DM, et al. The natural history of milk allergy in an observational cohort. *J Allergy Clin Immunol* 2013;131:805–12.
- Fiocchi A, Brozek J, Schunemann H, Bahna SL, von Berg A, Beyer K, et al. World Allergy Organization (WAO) Diagnosis and Rationale for Action against Cow's Milk Allergy (DRACMA) Guidelines. *Pediatr Allergy Immunol* 2010;21 (Suppl. 21):1–125.
- Bhatia J, Greer F. American Academy of Pediatrics Committee on Nutrition. Use of soy protein-based formulas in infant feeding. *Pediatrics* 2008;121:1062–8.
- American Academy of Pediatrics. Committee on Nutrition. Hypoallergenic infant formulas. *Pediatrics* 2000;106(2 Pt 1):346–9.
- Nowak-Węgrzyn A, Bloom KA, Sicherer SH, Shreffler WG, Noone S, Wanich N, et al. Tolerance to extensively heated milk in children with cow's milk allergy. *J Allergy Clin Immunol* 2008;122:342–7, 347 e1–2.
- Kim JS, Nowak-Węgrzyn A, Sicherer SH, Noone S, Moshier EL, Sampson HA. Dietary baked milk accelerates the resolution of cow's milk allergy in children. *J Allergy Clin Immunol* 2011;128:125–31 e2.
- Leonard SA, Sampson HA, Sicherer SH, Noone S, Moshier EL, Godbold J, et al. Dietary baked egg accelerates resolution of egg allergy in children. *J Allergy Clin Immunol* 2012;130:473–80 e1.
- Sicherer SH. Clinical implications of cross-reactive food allergens. *J Allergy Clin Immunol* 2001;108:881–90.
- Gendel SM. Comparison of international food allergen labeling regulations. *Regul Toxicol Pharmacol* 2012;63:279–85.
- Groetch M, Nowak-Węgrzyn A. Practical approach to nutrition and dietary intervention in pediatric food allergy. *Pediatr Allergy Immunol* 2013;24:212–21.
- Sampson HA, Gerth van Wijk R, Bindslev-Jensen C, Sicherer S, Teuber SS, Burks AW, et al. Standardizing double-blind, placebo-controlled oral food challenges: American Academy of Allergy, Asthma & Immunology-European Academy of Allergy and Clinical Immunology PRACTALL consensus report. *J Allergy Clin Immunol* 2012;130:1260–74.
- Nowak-Węgrzyn A, Assa'ad AH, Bahna SL, Bock SA, Sicherer SH, Teuber SS, et al. Work Group report: oral food challenge testing. *J Allergy Clin Immunol* 2009;123(Suppl. 6):S365–83.

# Immunotherapeutic Approaches to the Treatment of Food Allergy

STACIE M. JONES | A. WESLEY BURKS

## KEY POINTS

- Restoration or induction of immune tolerance is the primary goal for immunotherapy (IT) for food allergy, requiring significant immunomodulation to be effective.
- Emerging immunotherapeutic approaches to food allergy have largely induced desensitization but have met with some clinical successes, i.e. sustained unresponsiveness, in subsets of patients with food allergy.
- Immunomodulation has been noted with a variety of immunotherapy approaches to food allergy, with oral immunotherapy offering the most robust impact to date.
- Factors such as biomarkers or patient characteristics that can predict successful immunotherapy for food allergy are currently lacking.
- Further study in larger, more diverse populations of food-allergic patients is needed before immunotherapy for food allergy can be broadly applied to the clinical setting.

## Introduction

Food allergy is an immune-mediated disorder that can often be life-threatening but is always life-altering.<sup>1</sup> In food allergy significant immune deviation is evident, preventing oral tolerance of foods and resulting in allergic sensitization that leads to clinical allergy.<sup>2</sup> Immune deviation in food allergy includes reductions in regulatory T cell and tolerogenic dendritic cell activity, with Th2 skewing of the immune response and Th2-predominant cytokine production, increased IgE and elevated mast cell and basophil activation.<sup>2,3</sup> Restoration or induction of immune tolerance is the over-arching goal of any approach employing allergen immunotherapy for food allergy, requiring significant immunomodulation to be effective (Table 49-1). In fact, true immunologic tolerance to foods may not be achievable without some level of ongoing treatment or allergen exposure. Allergen immunotherapy has been documented for decades as a safe, effective treatment for many allergic disorders.<sup>4</sup> Despite its success for other allergic diseases, subcutaneous immunotherapy (SCIT) has not been implemented for the treatment of food allergy due to its unacceptable safety profile in early studies.<sup>5,6</sup> Due to the lack of active treatment options for food allergy, a vast amount of clinical and translational research has focussed on the development of novel immunotherapeutic strategies. Several approaches have emerged as promising future therapeutic options (Figure 49-1).

Common terms have been employed to describe the clinical state of allergic disease in response to immunotherapy. *Desensitization* refers to a change in the threshold dose of allergen required to induce allergic symptoms after allergen ingestion. This is a reversible state in which effector cells are rendered less reactive by administration of allergen, thus consistent allergen dosing is required to maintain protection from allergic reactions. *Tolerance* refers to the long-lasting beneficial effects of treatment, presumably due to the impact of therapy on adaptive immune cells that persists after the treatment is stopped. The immunomodulatory effects of desensitization can be seen early (days to weeks to months) in the course of immunotherapy; however, a state of relative tolerance is only achieved after a longer duration of therapy (months to years). *Sustained unresponsiveness* reflects a state of relative tolerance or longer-term desensitization requiring only intermittent allergen exposure to maintain suppression of allergic reactions; however, this state may be reversible when all treatment is discontinued. This chapter will highlight the allergen-specific and allergen-nonspecific immunomodulatory treatments that are currently under investigation for IgE-mediated food allergy, in addition to those in preclinical development (Table 49-2). None of these therapies has achieved US Food and Drug Administration (FDA) designation for safe use in patients, but several hold promise for the future.

## Allergen-Directed Immunotherapy

During the past decade, clinical trials in food allergy have focussed primarily on allergen-specific immunotherapy encompassing three major forms: oral (OIT), sublingual (SLIT) and epicutaneous (EPIT) immunotherapy. Each of these forms of immunotherapy is in different stages of investigation with similar immunologic targets but with clear differences in the route of administration, antigen dose and clinical research outcomes, and these therapies are the primary focus of this chapter (Table 49-3). Novel immunotherapeutic approaches are in early stages of development.

### ORAL IMMUNOTHERAPY (OIT)

Oral immunotherapy is the therapeutic approach most explored in clinical trials for food allergy to date. Unlike other therapies that have been adapted from preclinical studies or treatment models shown to be effective in other diseases, OIT trials began in earnest over 10 years ago in small, uncontrolled trials using commercially available food products. Early open-label trials have shown a beneficial response to OIT to a variety of allergens, such as milk, egg and fish, with evidence of clinical desensitization in up to 80% of subjects treated.<sup>7,8</sup> More recent trials have expanded to multicenter, randomized controlled OIT



trials that have taken advantage of the foods as 'therapeutic tools'. OIT products are viewed by the FDA as new therapeutics and are bound by FDA regulation for labeling and widespread, safe usage in the clinical setting. Most clinical trials to date are FDA registered and accessible through the NIH clinical trials registry ([www.clinicaltrials.gov](http://www.clinicaltrials.gov)).

Typically, OIT protocols encompass three phases of allergen delivery using a standard protocol in a well-controlled setting: (1) initial escalation dosing of 6 to 8 doses of allergen given rapidly during a single day under medical supervision; (2)

Immune Parameters	Food Allergy	Effective Immunotherapy
Allergen-specific IgE	Increased	Decreased
Allergen-specific IgG4	Negligible	Increased
Allergen-specific IgA	Negligible	Increased
IgE epitope binding	Variable	Targeted binding
Mast cell and basophil activation	Increased	Decreased
Th2 cytokines	Increased	Decreased
Regulatory T cell activity	Negligible	Increased

build-up dosing under observation weekly or biweekly until a target dose is reached after 6 to 12 months; and (3) daily maintenance dosing at home (typically for years). OIT is associated with beneficial short-term and longer-term treatment responses for most individuals through immunomodulation that involves tissue and circulating effector cells.<sup>2</sup> Despite the benefits seen, safety concerns further highlight the need for larger trials and FDA registration before widespread use is acceptable.<sup>9–11</sup>

Recent randomized, controlled, multicenter clinical trials have provided valuable efficacy and safety data for evaluation of OIT as an active treatment.<sup>12–19</sup> In a trial of peanut OIT, 28 children (ages 1–16 years) were randomized to receive peanut OIT (maintenance dose = 4,000 mg) versus placebo OIT.<sup>19</sup> Peanut OIT treatment was associated with clinical desensitization when compared to placebo OIT treatment after 12 months (5,000 mg [ $\sim$ 20 peanuts] vs 280 mg [ $\sim$ 1 peanut],  $P < .001$ ). In a recent randomized trial, 62% of children (ages 7–16 years) on active OIT could be desensitized to a dose of 1,400 mg ( $\sim$ 5 peanuts) of peanut after 6 months of OIT at a dose up to 800 mg compared to none of placebo OIT subjects ( $P < .001$ ).<sup>12</sup> Similar findings were noted during a 6-month milk OIT trial in 20 milk-allergic children (ages 6–21 years) randomized to milk OIT (maintenance dose = 500 mg) compared to placebo OIT when assessing change in reaction threshold at baseline oral food challenge (OFC) compared to 6-month OFC (5,100 mg [ $\sim$ 160 mL] vs 0 mg,  $P = .002$ ).<sup>18</sup> Other milk OIT

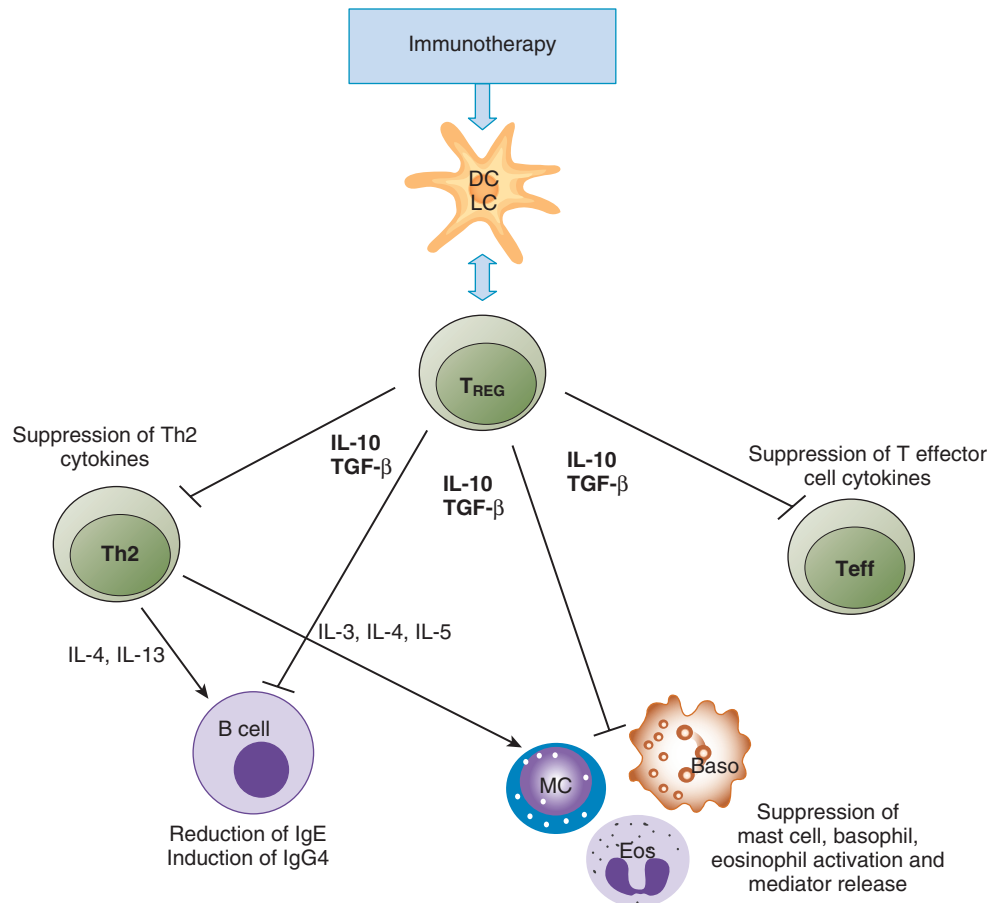

**Figure 49-1** Immunotherapeutic approaches for the treatment of food allergy requires modulation of the allergic response to foods through activation of dendritic cells (DC), Langerhans cells (LC) and regulatory T cells (T<sub>REG</sub>) with subsequent suppression of a variety of effector cell types (Th2 – type 2 T helper cells; B cells, MC – mast cells; Baso – basophils; Eos – eosinophils).

**TABLE 49-2 Immunotherapeutic Approaches for Treatment of Food Allergy**

Immunotherapy	Stage of Study	Food Allergen
<b>ALLERGEN-SPECIFIC THERAPY</b>		
Subcutaneous IT	Human Phase I	Peanut
Oral IT	Human Phase I–III	Peanut, milk, egg, fish, fruits
Heated antigen	Human Phase I–II	Egg, milk
Sublingual IT	Human Phase I–II	Peanut, milk, hazelnut, kiwi, peach
Epicutaneous IT	Human Phase I–II	Peanut, milk
Recombinant protein IT with adjuvants	Human Phase I	Peanut
Recombinant protein IT	Preclinical	Peanut
Peptide IT	Preclinical	Peanut, egg
Plasmid DNA IT	Preclinical	Peanut
ISS-ODN IT	Preclinical	Peanut
Human Fc-FC fusion proteins	Preclinical	Peanut
Engineered allergen	Preclinical	Egg, peanut, milk, fish, fruits
Mannoside-conjugated BSA	Preclinical	Bovine serum albumin (BSA)
Antigen-fixed leukocytes	Preclinical	Peanut
<b>ALLERGEN-NONSPECIFIC THERAPY</b>		
Anti-IgE therapy	Human Phase I–II	Peanut, milk
Traditional Chinese medicine	Human Phase I–II	Peanut, tree nut, fish, shellfish, sesame
Probiotics/Prebiotics	Longitudinal study	Nonspecific
<i>Lactococcus lactis</i> for peptide/cytokine delivery	Preclinical	Milk
Toll-like receptor 9	Preclinical	Peanut
<i>Trichuris suis</i> egg therapy	Preclinical	Peanut
<b>FUTURE THERAPY</b>		
Adjuvant treatment	Preclinical	
Nanoparticle use	Preclinical	
IgE receptor molecules	Preclinical	

trials in children have shown similar clinical findings.<sup>14–17</sup> In a study from the Consortium of Food Allergy Research (CoFAR), 55 egg-allergic children (ages 5–18 years) were randomized to egg versus placebo OIT.<sup>13</sup> After 10 months of OIT (maintenance dose = 2,000 mg), 55% of egg OIT subjects were desensitized to 5 g of egg (~ $\frac{3}{4}$  whole egg) compared to 0% of placebo OIT subjects (5,000 mg vs 50 mg;  $P < .001$ ), and 75% of egg OIT subjects passed a 10 g (~1.5 whole egg) OFC at 22 months. These studies highlight the efficacy of OIT induction of desensitization and treatment-specific immunomodulation (as described below).<sup>9–11</sup>

In a recent study, investigators delivered combination OIT to participants (ages 4–25 years) sensitized to up to five foods ( $N = 25$  subjects) compared to those that were mono-allergic ( $N = 15$ )<sup>20</sup> and reported that multi-allergen OIT could be delivered with similar safety and efficacy to single-allergen OIT. Alternatively, in a multisensitized mouse model of tree nut allergy, OIT with a single tree nut induced desensitization to multiple nuts with associated immune changes.<sup>21</sup> Further clinical studies are ongoing to evaluate the efficacy and safety of multi-allergen OIT and cross-reactive allergen OIT.

Several studies have evaluated longer-term outcomes of OIT, including sustained unresponsiveness.<sup>13,22–24</sup> All of these studies have been either uncontrolled, open-label studies or open-label extension phases of randomized, controlled trials that include years of OIT dosing. In an open-label study of 6 egg-allergic children (ages 3–13 years), all passed an OFC after 33 months of OIT and introduced egg into their diet.<sup>23</sup> After 5 years of peanut OIT (maintenance dose = 4,000 mg), 50% of subjects demonstrated sustained unresponsiveness to 5 g of peanut protein and were considered treatment successes with incorporation of a median of 555 mg/day (range, 0–4,000 mg/day) of peanut in their diets ~3 days/week.<sup>24</sup> During a 60-week trial of milk OIT compared to milk SLIT, OFCs were performed after 1 and 6 weeks off therapy in subjects demonstrating desensitization at week 60;<sup>22</sup> 10% failed at week 1 and 20% failed at 6 weeks. In the CoFAR egg OIT trial, sustained unresponsiveness treatment successes improved as therapy was extended, with 27.5% noted at 24 months, 47.5% at 36 months and 55% at 48 months.<sup>13,25</sup> Among peanut OIT subjects surveyed about duration of treatment effects, none of the treatment successes reported symptoms with peanut consumption after 3 to 4 years.<sup>24</sup> Follow-up of successful milk OIT yielded 22% of subjects reporting limitations with milk consumption due to symptoms, although for various reasons only 20% were ingesting milk on an unlimited basis.<sup>26</sup> Another study found that twice-weekly ingestion (150–200 mL) was effective to maintain

**TABLE 49-3 Comparison of Allergen-Targeted Immunotherapies in Clinical Trials**

	OIT	SLIT	EPIT
Daily maintenance dose	300–4,000 mg	2–7 mg	50–500 µg
Primary side-effects	Oral, gastrointestinal (systemic symptoms associated with infection, exercise, menses)	Oropharyngeal	Skin
Desensitization	Significant, sustained effect	Moderate, sustained effect	Ongoing investigation
Sustained unresponsiveness	Effective in subset of patients	Ongoing investigation	Ongoing investigation
Long-term tolerance	Ongoing investigation	Unknown	Unknown
Immune modulation	Significant	Present	Ongoing investigation

EPIT – Epicutaneous immunotherapy; OIT – oral immunotherapy; SLIT – sublingual immunotherapy.

desensitization.<sup>27</sup> Following 2 to 3 years after completion of egg OIT, 67% of egg OIT subjects compared to 18.2% of placebo OIT subjects could consume both baked and concentrated egg.<sup>25</sup> Overall, sustained unresponsiveness is possible in a subset of subjects, but the long-term impact of OIT remains unclear. To address this issue further, the Immune Tolerance Network IMPACT trial is evaluating long-term tolerance among peanut-allergic children (ages 1–4 years) in a randomized, controlled 3-year peanut OIT trial.

Immunologic changes associated with clinical findings following successful OIT have been compelling. Single-allergen OIT has been associated with beneficial immunomodulatory effects including reduced basophil and mast cell activation, down-regulation of Th2 effector cells and cytokine production, as well as initial increased T regulatory cell activity and reduced IgE antibodies with increased IgG4 antibodies.<sup>13,18,19,22,24,28–30</sup> Some of these changes following peanut OIT, in particular those related to basophil activation, are antigen specific but some are also associated with nonspecific stimuli including evidence of basophil suppression after anti-IgE stimulation or after nonspecific antigen (egg) stimulation.<sup>30</sup> Peanut OIT has also been shown to induce transient tolerance with associated increase in antigen-induced T<sub>REG</sub> function and intracellular IL-10 levels and decreases in methylation of Foxp3, a known indicator of T<sub>REG</sub> cell suppressive function.<sup>29</sup> Following long-term peanut OIT, treatment successes were associated with reduced peanut-specific IgE and Ara h 1 and 2, and skin prick tests (SPT) when compared to treatment failures, parameters that were predictive of outcomes.<sup>24</sup> Low baseline specific IgE levels were predictive of treatment success for desensitization in both milk<sup>31</sup> and egg<sup>32</sup> OIT studies, but not predictive of success in the multicenter CoFAR egg OIT study.<sup>13</sup> Analysis of IgE and IgG4 binding epitopes before and after milk<sup>33</sup> and peanut<sup>34</sup> OIT is particularly interesting. Reductions in IgE binding and increases in IgG4 binding with overlap of key binding epitopes are associated with response to therapy; however, in some individuals significant discordance indicates that antigen-nonspecific changes may play a role.<sup>34</sup> Overall, the immunodulation following OIT is often robust and strongly linked to clinical outcomes.

OIT trials have been conducted through study protocols under close monitoring by experienced research staff in clinical research centers with necessary rescue equipment and procedures in place. Although OIT has demonstrated clinical efficacy, meta-analyses highlight the fact that insufficient data exist for full efficacy assessments and safety concerns persist.<sup>9,10,35–38</sup> Generally, side-effects associated with OIT treatment trials are mild to moderate, predominantly oropharyngeal and easily treated;<sup>13,18,19,39,40</sup> however, more severe reactions have been reported. Currently, the highest rate of adverse events related to OIT occurs during the first year of therapy with up to ~10–15% of subjects withdrawing, often due to gastrointestinal side-effects.<sup>13,24</sup> During blinded peanut OIT,<sup>19</sup> symptoms were noted in most active treatment subjects when compared to placebo treated subjects. During OIT, ~45% of active subjects compared to ~10% of placebo subjects experienced dose-associated symptoms, primarily mild and oropharyngeal, but with ~1% requiring epinephrine.<sup>18,19</sup> During the first year of blinded egg OIT, 75% of 11,860 OIT doses were symptom free versus 96% of 4,018 placebo doses.<sup>13</sup> During years 3 and 4, 95% of OIT doses were symptom free.<sup>25</sup>

Acute illness with viral infections, menses and exercise have been associated with lowering the reaction threshold for

subjects on stable OIT dosing<sup>41</sup> and often require dose adjustments in the face of acute illness.<sup>39</sup> Additionally, eosinophilic esophagitis has been reported in association with OIT, adding potential risks for a subset of children.<sup>42,43</sup> The implementation of rush OIT protocols has been associated with increased adverse symptoms and has been generally abandoned as a viable treatment option.<sup>14,39,44,45</sup> Pre-treatment with omalizumab has shown promise for reducing side-effects and shortening time to maintenance therapy.<sup>46–48</sup> Overall, additional studies in larger study cohorts are needed before OIT can be sanctioned and encouraged for widespread use.<sup>9,10,35–38</sup> Larger scale Phase II and Phase III studies are underway currently for peanut OIT and are planned for other allergens.

Treatment with extensively heated (baked) milk and/or egg allergen may prove to be an important treatment option that mirrors allergen immunotherapy. Clinical trials performed in milk<sup>49</sup> and egg<sup>50</sup> allergic children have demonstrated that ~70–80% of milk or egg allergic children can safely ingest baked milk or egg products.<sup>49,50</sup> Daily consumption of 1 to 3 servings of baked allergen products was safe and associated with accelerated tolerance development and immunomodulation when compared to age-matched controls.<sup>50–53</sup> Questions remain regarding the best way to identify those patients tolerant of baked milk/egg, the effective dose required, the degree of heating needed, the role of the food matrices and the ability of heated proteins to induce lasting tolerance.

## SUBLINGUAL IMMUNOTHERAPY (SLIT)

Sublingual immunotherapy (SLIT) has been employed in asthma and allergic rhinitis in the form of allergen extracts and sublingual allergen tablets with favorable safety and efficacy profiles.<sup>54–56</sup> SLIT presumably works by allergen interaction with pro-tolerogenic Langerhans cells in the oral mucosa, leading to down-regulation of the allergic response. Several clinical trials have been conducted using SLIT for food allergy. As with OIT, SLIT protocols include escalation and maintenance dosing, although SLIT doses are smaller, generally less than 10 mg daily. Participants administer SLIT by placing a gradually increasing dose of allergen extract under the tongue, holding it there for several minutes and then spitting out or swallowing.

The first published reports of SLIT for food allergy appeared more than a decade ago, when SLIT for kiwi allergy was described in a case report in which a 29-year-old woman with a history of multiple anaphylactic reactions to kiwi was desensitized.<sup>57</sup> That patient subsequently underwent approximately 5 years of maintenance therapy with a solution made from fresh kiwi pulp and became tolerant of the fruit.<sup>58</sup> In a study of hazelnut SLIT, 22 adults received 8 to 12 weeks of treatment with hazelnut SLIT or placebo SLIT.<sup>59</sup> In the subsequent food challenge, almost half of patients in the hazelnut SLIT group consumed 20 g of hazelnut compared to only 9% of the placebo SLIT group. Systemic symptoms were noted in only 0.2%. Oropharyngeal symptoms were observed in 7.4% of subjects, many with oral allergy syndrome reported at baseline. In a study of peach SLIT, 49 adults received peach SLIT ( $N = 33$ ) or placebo SLIT ( $N = 16$ ) during 6 months of treatment.<sup>60</sup> During the post-therapy food challenge, the peach SLIT group consumed peach at levels that were 3-fold higher than those in the placebo SLIT group before experiencing symptoms.

SLIT studies have expanded to include both pediatric and adult patients with milk or peanut allergy in the last few years. In a 6-month, open-label study of 8 children (age >6 years) with cow's milk allergy, milk SLIT led to an increase in the mean volume of milk that elicited allergy symptoms from 39 mL to 143 mL.<sup>61</sup> In a study of 30 milk-allergic children (ages 6–17 years), milk SLIT was compared to milk OIT in a two-center study.<sup>22</sup> Participants were randomly assigned to receive SLIT alone (7 mg) or SLIT followed by OIT at two different doses (1 or 2 g) during 60 weeks of immunotherapy. At the end of the study, 1 of 10 SLIT-only participants achieved desensitization to 8 g of milk protein, while 6 of 10 participants in the lower-dose SLIT+OIT group and 8 of 10 patients in the higher-dose SLIT+OIT group achieved desensitization. Overall, SLIT in combination with OIT was associated with more robust clinical benefits than SLIT alone; however, systemic side-effects occurred only in the SLIT+OIT groups with higher levels of antihistamine and epinephrine usage. Symptoms reported with milk SLIT were limited to the oropharynx.<sup>22</sup>

The first randomized, controlled trial of peanut SLIT was performed in a single-center study of 18 children (ages 1–11 years) receiving 12 months of SLIT (maintenance dose = 2 mg daily) with peanut or placebo.<sup>62</sup> At the conclusion of 1 year of treatment, those receiving peanut SLIT were able to safely consume 1,710 mg (~8 peanuts) of peanut protein, compared to only 85 mg (<0.5 peanut) in those receiving peanut SLIT ( $P = .011$ ), representing a 20-fold increase in peanut consumption. During dosing, side-effects were minimal and localized to the oropharynx, noted in 11.5% of peanut SLIT subjects compared to 8.6% of placebo SLIT subjects. Symptoms were typically untreated, and no participant required epinephrine during treatment. Immunologic changes were noted in peanut SLIT subjects when compared from baseline to OFC at 12 months including decreased peanut-specific IgE ( $P = .003$ ), SPT size ( $P = .02$ ), basophil activation ( $P = .009$ ), and IL-5 levels ( $P = .015$ ) with increase in peanut-specific IgG4 ( $P = .014$ ). Clinical benefits in addition to evidence of immunomodulation suggested modification of the allergic response by peanut SLIT in these young children. A subsequent multicenter study from CoFAR of 40 peanut-allergic patients (ages 12–40 years) evaluated the efficacy of peanut SLIT vs placebo SLIT.<sup>63</sup> Treatment success was defined during OFC when 5 g of peanut protein was consumed or when a 10-fold or higher increase in peanut protein consumption was achieved when comparing baseline to follow-up OFC. After 44 weeks of therapy (target maintenance dose = 1,386  $\mu$ g), 14 (70%) of 20 subjects who received peanut SLIT compared to only 3 (15%) of 20 subjects who received placebo SLIT demonstrated treatment success: primarily greater than a 10-fold increase in eliciting dose over baseline challenge. The median dose of peanut consumed at the 44-week OFC compared to baseline OFC was significantly higher for peanut SLIT subjects (371 mg [about 1 peanut] vs 21 mg,  $P = .01$ ) when compared to placebo SLIT subjects (146 mg vs 71 mg,  $P = .14$ ). When evaluation took place at week 68 the mean consumed dose rose to 996 mg, which was significantly higher than at week 44 ( $P = .05$ ). For the 12 of 17 placebo subjects that crossed over to higher dose SLIT (target maintenance dose = 3,696  $\mu$ g) and completed a 5 g OFC, the median consumed dose was higher than at baseline OFC (603 mg vs 71 mg,  $P = .02$ ). Although the results were encouraging, none of the subjects treated with low-dose or high-dose SLIT was able to consume the full 5 g OFC during the desensitization phase. Peanut SLIT was well tolerated with 95%

of doses being symptom free when local oropharyngeal symptoms were excluded. Clinical outcomes were associated with only modest immunologic changes including reductions in basophil activation and modest changes in titrated skin tests. No significant changes were noted in peanut-specific IgE or IgG4 levels. Differences in the two peanut SLIT studies may be explained by the difference in ages of the study cohorts, subject selection and differences in target maintenance doses, indicating that further study is warranted.

A retrospective comparison study of peanut-allergic children treated with either peanut OIT or SLIT indicated that after 12 months of therapy patients who received SLIT reacted at lower eliciting dose thresholds and were less likely to pass food challenges evaluating desensitization.<sup>64</sup> Thus, available evidence for milk and peanut allergy suggests that SLIT therapy is less effective than OIT for desensitization but has a better safety profile.<sup>22,64</sup> Studies of SLIT have also largely excluded patients with a history of severe allergic reactions. Among patients who have undergone treatment, response has been variable and potentially age dependent and allergen dependent. Therefore, the applicability of SLIT in the general food-allergic population remains unclear. There are ongoing SLIT studies in younger age groups and using different SLIT delivery systems that should help us better understand the possible role of this type of immunotherapy for food allergy for the future.

## EPICUTANEOUS IMMUNOTHERAPY (EPIT)

Epicutaneous immunotherapy is a newer form of immunotherapy that utilizes a novel delivery of allergen to the skin surface through application of an allergen-containing patch. EPIT has been utilized for grass pollen-induced allergic rhinitis with demonstrated efficacy and safety.<sup>65</sup> In preclinical studies of EPIT for food allergy, effective antigen delivery and treatment outcomes have been noted and have led to clinical trials in milk and peanut allergy. EPIT acts by delivering a small dose of allergenic protein directly to the epidermal layer of the skin where it is taken up, activating Langerhans cells that subsequently traffic to regional lymph nodes and lead to down-regulation of effector cell responses.<sup>66–69</sup> In mouse studies, fluorescently labeled allergen (Alexa488-ovalbumin) applied via an allergen patch remained in the epidermal layer without evidence of systemic absorption but with induction of downstream immunologic effects.<sup>67</sup> In mouse studies, investigators sensitized mice to ovalbumin, peanut or aeroallergen and then treated with EPIT, SCIT or sham therapy for 8 weeks.<sup>70</sup> Mice treated with EPIT showed reduced airway hyperreactivity to inhaled allergen, decreased allergen-specific IgE levels and increased allergen-specific IgG2a when compared to controls ( $P < .05$ ), changes that were similar to treatment-induced effects noted with SCIT.<sup>70</sup> Reduced inflammation was also noted on bronchoalveolar lavage with evidence for decreased eosinophils, eotaxin and cytokines with both EPIT and SCIT when compared to controls ( $P < .001$ ). Further preclinical studies have demonstrated allergen-specific induction in tolerogenic regulatory T cells with repeated allergen patch application, a treatment effect that was eliminated when EPIT was applied to tape-stripped skin.<sup>71</sup> In a mouse model of peanut-induced eosinophilic gastrointestinal disorders, peanut EPIT treatment resulted in expansion of a CD25+ T regulatory cell population that was long-lasting and that could be adoptively transferred to peanut-sensitized, untreated animals to provide



protection.<sup>72,73</sup> These findings from preclinical studies have highlighted the novel mechanistic action of EPIT and beneficial treatment effects that have paved the way for the first human studies in milk- and peanut-allergic individuals.

To date, all EPIT studies conducted for food allergy have employed the technology developed by DBV Technologies, Inc. (Paris, France). This technology consists of a small, adhesive patch, known as the Viaskin™ device, that has been electrostatically coated with allergen and is applied to the upper arm or interscapular space. The first study conducted was a 3-month double-blind, placebo-controlled pilot study in milk-allergic infants and children (3 months to 15 years).<sup>74</sup> Nineteen subjects were randomized to treatment with milk or placebo EPIT applied at 48-hour intervals during 3 months of treatment (using the Diallertest™ device, a precursor to Viaskin™). The cumulated dose of cow's milk consumed during OFC (baseline vs 3 months) trended higher in the milk EPIT group ( $1.77 \pm 2.98$  mL vs  $23.61 \pm 28.61$  mL) compared to the placebo group ( $4.36 \pm 5.87$  mL vs  $5.44 \pm 5.88$  mL) ( $P = .13$ ). Adverse events were higher among milk EPIT treated subjects when compared to placebo treatment and were limited to mild skin reactions at the patch site and increased risk of local eczema (OR 8.20; 2.72–24.5;  $P < .001$ ). This limited duration pilot study of EPIT in food-allergic children provided early evidence that EPIT could be used safely with potential for beneficial clinical outcomes.

Since completion of the EPIT pilot study in children, the focus of clinical trials for EPIT has been on peanut allergy, with both Phase I and Phase II studies conducted using the Viaskin™ patch device. A Phase I safety trial was conducted among 100 peanut-allergic participants (ages 6–25 years), categorized as severe and nonsevere based on reaction history, using a randomized, double-blind, placebo-controlled trial design comparing placebo Viaskin™ to four different doses of peanut Viaskin™ patches administered over 2 weeks of therapy. The peanut Viaskin™ proved safe and convenient up to a dose of 250 µg for children and up to 500 µg in adolescents and adults.<sup>75</sup> Overall, 2 of 80 active EPIT and 1 of 20 placebo EPIT subjects dropped out due to adverse events; 90% experienced mild or moderate local symptoms, and systemic symptoms were mostly mild and transient, with no severe reactions and no epinephrine use.

The first peanut efficacy trial (ARACHILD), a randomized, controlled study, included 54 peanut-allergic children (ages 5–17 years), all treated with the peanut patch (100 µg pp) and challenged after 6 months of blinded therapy. OFCs were conducted at 6-month intervals over an 18-month period to assess reaction threshold. Safety data after 12 to 18 months were satisfactory and consistent with Phase I results. Treatment was associated with some level of desensitization with up to 67% responders (defined as  $\geq 10$ -fold increase in cumulative reactive dose from baseline) at 18 months with 4 subjects reaching 1–2.5 g of peanut protein ( $\sim 3.5$ –8 peanuts).<sup>76</sup>

A large randomized, controlled Phase IIb trial (VIPES) has enrolled 221 highly peanut-allergic individuals (ages 6–55 years) in 22 centers in the USA and Europe, for a 1-year treatment comparison of peanut EPIT vs placebo EPIT. Results are expected for 2015 with a planned extension phase up to 36 months. Additionally, the CoFAR study group has initiated a randomized, controlled study of peanut EPIT planned for 30 months of treatment in 75 children and young adults (ages 4–25 years). Additional EPIT studies with other allergens are in planning and implementation stages.

## NOVEL IMMUNOTHERAPY APPROACHES IN EARLY DEVELOPMENT

Novel immunotherapeutic applications in food allergy are under investigation in murine models.<sup>77</sup> *Modified or recombinant allergen immunotherapy* has taken advantage of recombinant technology to alter the host response to allergen through modification of the antigenic features of the protein and has been used in preclinical trials and a single Phase I study. Based on positive findings from a peanut mouse model using heat-killed *Escherichia coli* (HKE) in combination with modified Ara h1, 2, and 3 proteins (HKE-EMP123),<sup>78,79</sup> a Phase I clinical trial using HKE-EMP123 delivered rectally was conducted in nonallergic adults and peanut-allergic adults.<sup>80</sup> In peanut-allergic subjects, 50% had significant allergic reactions preventing further dosing (30% required epinephrine), while healthy controls tolerated the treatment. Other immune-specific approaches in preclinical studies include peptide vaccine immunotherapy, plasmid DNA immunotherapy, cytokine-modulated immunotherapy, immunostimulatory sequence-conjugated protein-modulated immunotherapy, human immunoglobulin fusion proteins, sugar-conjugated BSA and antigen-fixed leukocytes.<sup>77,81</sup> These approaches may provide an important first step in organ-targeted immunotherapy with molecules that induce immunomodulation with improved safety profiles.

## Allergen Nonspecific Immunotherapy

Several immunomodulatory therapies that globally impact the allergic immune response are under investigation as single-agent treatments or as adjunctive treatments to synergize with allergen-targeted immunotherapy. These treatment approaches do not target specific allergens, thus they may be applicable for individuals allergic to multiple allergens or those with severe allergic reactions that could benefit from additional safety considerations.

## HUMANIZED MONOCLONAL ANTI-IgE

Humanized monoclonal anti-IgE has proven to be a valuable biologic therapy for a variety of allergic disorders. Omalizumab, a recombinant, humanized, monoclonal anti-IgE antibody, is FDA approved for the treatment of allergic asthma and chronic urticaria and has demonstrated efficacy when used in concert with rush immunotherapy for allergic rhinitis,<sup>82</sup> as an adjunctive therapy to minimize systemic immunotherapy reactions in allergic asthmatics<sup>83</sup> and as an effective treatment for chronic urticaria.<sup>84</sup> The mechanism of action involves binding of antibody to the Fc portion of free IgE molecules with added benefit of reducing high-affinity receptors on effector cells, thereby reducing the potential for anaphylaxis in a global, nonallergen targeted manner.<sup>84</sup> These molecules are associated with an extended half-life of IgE and treatment response that are typically reversible with drug cessation. The first clinical trial of anti-IgE for peanut allergy used a novel antibody, Hu-901, to demonstrate efficacy in increasing the reaction threshold to peanut during oral food challenge (OFC) from 178 mg to 2,805 mg.<sup>85</sup> However,  $\sim 25\%$  of subjects were non-responders. A second multicenter, randomized, controlled trial using omalizumab to treat peanut allergy was initiated in 26 subjects, but was stopped prematurely due to safety issues during baseline OFCs.<sup>86</sup> Fourteen subjects randomized to receive omalizumab

or placebo during 20 to 22 weeks of treatment completed OFC assessment prior to study discontinuation. The dose threshold of peanut flour at  $\geq 1,000$  mg was noted in 44% of omalizumab-treated subjects compared to 20% of placebo-treated subjects, but over half of the subjects did not reach the 1,000 mg threshold, leaving unanswered questions about efficacy.

Omalizumab treatment before and during OIT has shown benefits in reducing side-effects and shortening build-up dosing time to maintenance therapy during a trial of 11 subjects treated with milk OIT<sup>47</sup> and during a trial of 13 children treated with peanut OIT.<sup>48</sup> Both studies report lower overall side-effect profiles during build-up and maintenance dosing. Additionally, omalizumab pre-treatment in both studies reduced the time interval of OIT build-up phase to maintenance therapy by several months when compared to other studies employing OIT alone. In a Phase I study of 25 children and adults with multi-food allergy, 16-week pre-treatment with omalizumab was used to advance multi-allergen OIT over weeks rather than months with 94% of dosing reactions reported as mild and only one subject reported to have a severe allergic reaction.<sup>46</sup> Adverse reactions were still noted in all of the pilot studies, some requiring epinephrine administration, thus the risk of OIT is not fully mitigated by omalizumab pre-treatment based on current studies. New studies are currently assessing the role of omalizumab combined with OIT in randomized, controlled multicenter trials. Additionally, other molecules in preclinical development are focussed on improving or altering binding affinity of anti-IgE molecules<sup>87</sup> while others focus on displacement of IgE from its receptor.<sup>88</sup>

## TRADITIONAL CHINESE MEDICINE

Traditional Chinese medicine has been used for centuries to treat a variety of disorders, with anecdotal reports of medicinal benefits for allergic disorders. FAHF-2 was developed as a formulation of nine Chinese herbs and studied extensively in preclinical studies. FAHF-2 was shown to block peanut-induced anaphylaxis and induce immunologic changes when comparing peanut-sensitized to sham-sensitized mice, with effects sustained for up to 6 months (25% of the lifespan of a mouse).<sup>89</sup> During a Phase I study,<sup>90</sup> subjects received FAHF-2 tablets or placebo over 1 week. Treatment was well tolerated, with only minor gastrointestinal symptoms in ~10% of participants and with associated reductions in serum IL-5 levels. A Phase II, multicenter clinical trial has recently been completed in multifeed-allergic adolescents and adults (ages 12–50 years). A treatment response was not identified but may have been influenced by poor compliance by participants requiring dosing of 10 tablets three times daily over 6 months of treatment.<sup>91</sup> A newer form of treatment, designed to reduce dosing barriers, is in development.

## OTHER THERAPIES

Based on an ever-increasing body of evidence about the role of host microbiome in allergic and inflammatory disease,<sup>92–95</sup>

therapeutic intervention with agents that alter the microbiome and impact the immune response may be of value. Probiotics, such as *Lactobacillus* and *Bifidobacterium* species, and oligosaccharide prebiotics promote beneficial bacterial colonization of the gastrointestinal tract and may have immunomodulatory effects.<sup>95,96</sup> To date, studies using probiotics or prebiotics have not been utilized effectively in clinical trials for food allergy. Other therapies, such as *Lactococcus lactis* supplementation and expression systems and Toll-like receptor-9 (TLR9) agonists, have shown some benefit in allergic animal models.<sup>81</sup> *Trichuris suis* egg therapy has shown benefit for autoimmune disorders and in a murine model of food allergy, but side-effects have limited the overall benefit to date.<sup>81</sup>

## Future Approaches to Immunotherapy

Novel therapies have been utilized in vaccine development for infectious diseases, cancer and neurologic inflammatory disorders, using targeted treatment to enhance immune responses and/or target treatments to specific organ systems. Immune adjuvants are such agents that work by amplification of the adaptive immune response to incite immune deviation. Lipopolysaccharide-derived lipid A ligands of the Toll-like receptor-4 (TLR4) pathway have been used effectively in human vaccines for infectious disease and cancer and in combination with SCIT and SLIT to enhance treatment responses for allergic disease.<sup>97–99</sup> These TLR4 adjuvants have not been studied in food allergy trials to date.

Nanotechnology may provide another treatment approach in food allergy. Nanoparticles are in research and development phases to deliver medications for numerous diseases.<sup>100</sup> Because of their small size (<100 nm) and potential for tissue targeting, nanoparticles can be delivered through a variety of routes to a variety of specific tissues to impact local immune environments and have been evaluated with some success in several preclinical studies for food allergy.<sup>101,102</sup>

## Conclusions

In conclusion, immunotherapeutic approaches for the treatment of food allergy hold promise for the future. These therapies are not fully vetted in large populations and require further study before widespread clinical use can be recommended. Several of these approaches are in Phase II clinical trials with Phase III studies planned targeting future FDA registration. The future is bright for patients with food allergy and for clinicians and families who are seeking treatment options that will make a difference.

The complete reference list can be found on the companion Expert Consult website at <http://www.expertconsult.inkling.com>. 

**KEY REFERENCES**

2. Vickery BP, Scurlock AM, Jones SM, Burks AW. Mechanisms of immune tolerance relevant to food allergy. *J Allergy Clin Immunol* 2011;127:576–84.
11. Wood RA, Sampson HA. Oral immunotherapy for the treatment of peanut allergy: is it ready for prime time? *J Allergy Clin Immunol Pract* 2014;2:97–8.
13. Burks AW, Jones SM, Wood RA, Fleischer DM, Sicherer SH, Lindblad RW, et al. Oral immunotherapy for treatment of egg allergy in children. *N Engl J Med* 2012;367:233–43.
18. Skripak JM, Nash SD, Rowley H, Brereton NH, Oh S, Hamilton RG, et al. A randomized, double-blind, placebo-controlled study of milk oral immunotherapy for cow's milk allergy. *J Allergy Clin Immunol* 2008;122:1154–60.
19. Varshney P, Jones SM, Scurlock AM, Perry TT, Kemper A, Steele P, et al. A randomized controlled study of peanut oral immunotherapy: clinical desensitization and modulation of the allergic response. *J Allergy Clin Immunol* 2011;127:654–60.
41. Varshney P, Steele PH, Vickery BP, Bird JA, Thyagarajan A, Scurlock AM, et al. Adverse reactions during peanut oral immunotherapy home dosing. *J Allergy Clin Immunol* 2009;124:1351–2.
47. Nadeau KC, Schneider LC, Hoyte L, Borrás I, Umetsu DT. Rapid oral desensitization in combination with omalizumab therapy in patients with cow's milk allergy. *J Allergy Clin Immunol* 2011;127:1622–4.
48. Schneider LC, Rachid R, LeBovidge J, Blood E, Mittal M, Umetsu DT. A pilot study of omalizumab to facilitate rapid oral desensitization in high-risk peanut-allergic patients. *J Allergy Clin Immunol* 2013;132:1368–74.
62. Kim EH, Bird JA, Kulis M, Laubach S, Pons L, Shreffler W, et al. Sublingual immunotherapy for peanut allergy: clinical and immunologic evidence of desensitization. *J Allergy Clin Immunol* 2011;127:640–6.
63. Fleischer DM, Burks AW, Vickery BP, Scurlock AM, Wood RA, Jones SM, et al. Sublingual immunotherapy for peanut allergy: a randomized, double-blind, placebo-controlled multicenter trial. *J Allergy Clin Immunol* 2013;131:119–127 e111–117.

## REFERENCES

- Boyce JA, Assa'ad A, Burks AW, Jones SM, Sampson HA, Wood RA, et al. Guidelines for the diagnosis and management of food allergy in the United States: report of the NIAID-sponsored expert panel. *J Allergy Clin Immunol* 2010;126(Suppl. 6):S1–58.
- Vickery BP, Scurlock AM, Jones SM, Burks AW. Mechanisms of immune tolerance relevant to food allergy. *J Allergy Clin Immunol* 2011;127:576–84.
- Johnston LK, Chien KB, Bryce PJ. The immunology of food allergy. *J Immunol* 2014;192:2529–34.
- Akdis CA, Akdis M. Mechanisms of allergen-specific immunotherapy. *J Allergy Clin Immunol* 2011;127:18–27.
- Nelson HS, Lahr J, Rule R, Bock A, Leung D. Treatment of anaphylactic sensitivity to peanuts by immunotherapy with injections of aqueous peanut extract. *J Allergy Clin Immunol* 1997;99(6 Pt 1):744–51.
- Oppenheimer JJ, Nelson HS, Bock SA, Christensen F, Leung DY. Treatment of peanut allergy with rush immunotherapy. *J Allergy Clin Immunol* 1992;90:256–62.
- Meglio P, Bartone E, Plantamura M, Arabito E, Giampietro PG. A protocol for oral desensitization in children with IgE-mediated cow's milk allergy. *Allergy* 2004;59:980–7.
- Patriarca G, Nucera E, Roncallo C, Pollastrini E, Bartolozzi F, De Pasquale T, et al. Oral desensitizing treatment in food allergy: clinical and immunological results. *Aliment Pharmacol Ther* 2003;17:459–65.
- Nurmatov U, Devereux G, Worth A, Healy L, Sheikh A. Effectiveness and safety of orally administered immunotherapy for food allergies: a systematic review and meta-analysis. *Br J Nutr* 2014;111:12–22.
- Sun J, Hui X, Ying W, Liu D, Wang X. Efficacy of allergen-specific immunotherapy for peanut allergy: a meta-analysis of randomized controlled trials. *Allergy Asthma Proc* 2014;35:171–7.
- Wood RA, Sampson HA. Oral immunotherapy for the treatment of peanut allergy: is it ready for prime time? *J Allergy Clin Immunol Pract* 2014;2:97–8.
- Anagnostou K, Islam S, King Y, Foley L, Pasea L, Bond S, et al. Assessing the efficacy of oral immunotherapy for the desensitisation of peanut allergy in children (STOP II): a phase 2 randomised controlled trial. *Lancet* 2014;383:1297–304.
- Burks AW, Jones SM, Wood RA, Fleischer DM, Sicherer SH, Lindblad RW, et al. Oral immunotherapy for treatment of egg allergy in children. *N Engl J Med* 2012;367:233–43.
- Longo G, Barbi E, Berti I, Meneghetti R, Pittalis A, Ronfani L, et al. Specific oral tolerance induction in children with very severe cow's milk-induced reactions. *J Allergy Clin Immunol* 2008;121:343–7.
- Martorell A, De la Hoz B, Ibanez MD, Bone J, Terrados MS, Michavila A, et al. Oral desensitization as a useful treatment in 2-year-old children with cow's milk allergy. *Clin Exp Allergy* 2011;41:1297–304.
- Pajno GB, Caminiti L, Ruggeri P, De Luca R, Vita D, La Rosa M, et al. Oral immunotherapy for cow's milk allergy with a weekly up-dosing regimen: a randomized single-blind controlled study. *Ann Allergy Asthma Immunol* 2010;105:376–81.
- Salmivesi S, Korppi M, Makela MJ, Paasilta M. Milk oral immunotherapy is effective in school-aged children. *Acta Paediatr* 2013;102:172–6.
- Skripak JM, Nash SD, Rowley H, Brereton NH, Oh S, Hamilton RG, et al. A randomized, double-blind, placebo-controlled study of milk oral immunotherapy for cow's milk allergy. *J Allergy Clin Immunol* 2008;122:1154–60.
- Varshney P, Jones SM, Scurlock AM, Perry TT, Kemper A, Steele P, et al. A randomized controlled study of peanut oral immunotherapy: clinical desensitization and modulation of the allergic response. *J Allergy Clin Immunol* 2011;127:654–60.
- Begin P, Winterroth LC, Dominguez T, Wilson SP, Bacal L, Mehrotra A, et al. Safety and feasibility of oral immunotherapy to multiple allergens for food allergy. *Allergy Asthma Clin Immunol* 2014;10:1.
- Kulis M, Li Y, Lane H, Pons L, Burks W. Single-tree nut immunotherapy attenuates allergic reactions in mice with hypersensitivity to multiple tree nuts. *J Allergy Clin Immunol* 2010;127:81–8.
- Keet CA, Frischmeyer-Guerrero PA, Thyagarajan A, Schroeder JT, Hamilton RG, Boden S, et al. The safety and efficacy of sublingual and oral immunotherapy for milk allergy. *J Allergy Clin Immunol* 2012;129:448–55, 455 e441–445.
- Vickery BP, Pons L, Kulis M, Steele P, Jones SM, Burks AW. Individualized IgE-based dosing of egg oral immunotherapy and the development of tolerance. *Ann Allergy Asthma Immunol* 2010;105:444–50.
- Vickery BP, Scurlock AM, Kulis M, Steele PH, Kamilaris J, Berglund JP, et al. Sustained unresponsiveness to peanut in subjects who have completed peanut oral immunotherapy. *J Allergy Clin Immunol* 2014;133:468–75.
- Jones SM, Burks A, Wood R, Fleischer DM, Sicherer SH, Henning A, et al. Long-lasting egg consumption in egg allergic children treated with oral immunotherapy (OIT): follow-up from the Consortium of Food Allergy Research (CoFAR) Study. *J Allergy Clin Immunol* 2014;133:AB403.
- Keet CA, Seopaul S, Knorr S, Narisety S, Skripak J, Wood RA. Long-term follow-up of oral immunotherapy for cow's milk allergy. *J Allergy Clin Immunol* 2013;132:737–739 e736.
- Pajno GB, Caminiti L, Salzano G, Crisafulli G, Aversa T, Messina MF, et al. Comparison between two maintenance feeding regimens after successful cow's milk oral desensitization. *Pediatr Allergy Immunol* 2013;24:376–81.
- Jones SM, Pons L, Roberts JL, Scurlock AM, Perry TT, Kulis M, et al. Clinical efficacy and immune regulation with peanut oral immunotherapy. *J Allergy Clin Immunol* 2009;124:292–300, 300.
- Syed A, Garcia MA, Lyu SC, Bucayu R, Kohli A, Ishida S, et al. Peanut oral immunotherapy results in increased antigen-induced regulatory T-cell function and hypomethylation of forkhead box protein 3 (FOXP3). *J Allergy Clin Immunol* 2014;133:500–10.
- Thyagarajan A, Jones SM, Calatroni A, Pons L, Kulis M, Woo CS, et al. Evidence of pathway-specific basophil anergy induced by peanut oral immunotherapy in peanut-allergic children. *Clin Exp Allergy* 2012;42:1197–205.
- Garcia-Ara C, Pedrosa M, Belver MT, Martin-Munoz MF, Quirce S, Boyano-Martinez T. Efficacy and safety of oral desensitization in children with cow's milk allergy according to their serum specific IgE level. *Ann Allergy Asthma Immunol* 2013;110:290–4.
- Vazquez-Ortiz M, Alvaro M, Piquer M, Dominguez O, Machinena A, Martín-Mateos MA, et al. Baseline specific IgE levels are useful to predict safety of oral immunotherapy in egg-allergic children. *Clin Exp Allergy* 2014;44:130–41.
- Savilahti EM, Kuitunen M, Valori M, Rantanen V, Bardina L, Gimenez G, et al. Use of IgE and IgG4 epitope binding to predict the outcome of oral immunotherapy in cow's milk allergy. *Pediatr Allergy Immunol* 2014;25:227–35.
- Vickery BP, Lin J, Kulis M, Fu Z, Steele PH, Jones SM, et al. Peanut oral immunotherapy modifies IgE and IgG4 responses to major peanut allergens. *J Allergy Clin Immunol* 2013;131:128–134 e121–123.
- Brozek JL, Terracciano L, Hsu J, Kreis J, Compalati E, Santesso N, et al. Oral immunotherapy for IgE-mediated cow's milk allergy: a systematic review and meta-analysis. *Clin Exp Allergy* 2012;42:363–74.
- Fisher HR, Du TG, Lack G. Specific oral tolerance induction in food allergic children: is oral desensitisation more effective than allergen avoidance? a meta-analysis of published RCTs. *Arch Dis Child* 2011;96:259–64.
- Vazquez-Ortiz M, Alvaro-Lozano M, Alsina L, Garcia-Paba MB, Piquer-Gibert M, Giner-Munoz MT, et al. Safety and predictors of adverse events during oral immunotherapy for milk allergy: severity of reaction at oral challenge, specific IgE and prick test. *Clin Exp Allergy* 2013;43:92–102.
- Yeung JP, Kloda LA, McDevitt J, Ben-Shoshan M, Alizadehfar R. Oral immunotherapy for milk allergy. *Cochrane Database Syst Rev* 2012;11:CD009542.
- Blumchen K, Ulbricht H, Staden U, Dobberstein K, Beschoner J, de Oliveira LC, et al. Oral peanut immunotherapy in children with peanut anaphylaxis. *J Allergy Clin Immunol* 2010;126:83–91.
- Hofmann AM, Scurlock AM, Jones SM, Palmer KP, Lokhnygina Y, Steele PH, et al. Safety of a peanut oral immunotherapy protocol in children with peanut allergy. *J Allergy Clin Immunol* 2009;124:286–91, 291.
- Varshney P, Steele PH, Vickery BP, Bird JA, Thyagarajan A, Scurlock AM, et al. Adverse reactions during peanut oral immunotherapy home dosing. *J Allergy Clin Immunol* 2009;124:1351–2.
- Morais Silva P, Antunes J, Chambel M, Prates S, Leiria Pinto P. Diagnosis of eosinophilic esophagitis in an infant undergoing milk oral immunotherapy – a case report. *Eur Ann Allergy Clin Immunol* 2014;46:154–6.
- Sanchez-Garcia S, Rodriguez Del Rio P, Escudero C, Martinez-Gomez MJ, Ibanez MD. Possible eosinophilic esophagitis induced by milk oral immunotherapy. *J Allergy Clin Immunol* 2012;129:1155–7.
- Barbi E, Longo G, Berti I, Neri E, Saccari A, Rubert L, et al. Adverse effects during specific oral tolerance induction: in-hospital 'rush' phase. *Eur Ann Allergy Clin Immunol* 2012;44:18–25.



45. Pajno GB. Oral desensitization for milk allergy in children: state of the art. *Curr Opin Allergy Clin Immunol* 2011;11:560–4.
46. Begin P, Dominguez T, Wilson SP, Bacal L, Mehrotra A, Kausch B, et al. Phase I results of safety and tolerability in a rush oral immunotherapy protocol to multiple foods using omalizumab. *Allergy Asthma Clin Immunol* 2014; 10:7.
47. Nadeau KC, Schneider LC, Hoyte L, Borrás I, Umetsu DT. Rapid oral desensitization in combination with omalizumab therapy in patients with cow's milk allergy. *J Allergy Clin Immunol* 2011;127:1622–4.
48. Schneider LC, Rachid R, LeBovidge J, Blood E, Mittal M, Umetsu DT. A pilot study of omalizumab to facilitate rapid oral desensitization in high-risk peanut-allergic patients. *J Allergy Clin Immunol* 2013;132:1368–74.
49. Nowak-Węgrzyn A, Bloom KA, Sicherer SH, Shreffler WG, Noone S, Wanich N, et al. Tolerance to extensively heated milk in children with cow's milk allergy. *J Allergy Clin Immunol* 2008;122:342–7, 347.
50. Lemon-Mule H, Sampson HA, Sicherer SH, Shreffler WG, Noone S, Nowak-Węgrzyn A. Immunologic changes in children with egg allergy ingesting extensively heated egg. *J Allergy Clin Immunol* 2008;122:977–83.
51. Kim JS, Nowak-Węgrzyn A, Sicherer SH, Noone S, Moshier EL, Sampson HA. Dietary baked milk accelerates the resolution of cow's milk allergy in children. *J Allergy Clin Immunol* 2011;128:125–31.
52. Ford LS, Bloom KA, Nowak-Węgrzyn AH, Shreffler WG, Masilamani M, Sampson HA. Basophil reactivity, wheal size, and immunoglobulin levels distinguish degrees of cow's milk tolerance. *J Allergy Clin Immunol* 2013; 131:180–186 e181–183.
53. Shreffler WG. Evaluation of basophil activation in food allergy: present and future applications. *Curr Opin Allergy Clin Immunol* 2006;6:226–33.
54. Cox LS, Larenas LD, Nolte H, Weldon D, Finegold I, Nelson HS. Sublingual immunotherapy: a comprehensive review. *J Allergy Clin Immunol* 2006;117:1021–35.
55. Radulovic S, Calderon MA, Wilson D, Durham S. Sublingual immunotherapy for allergic rhinitis. *Cochrane Database Syst Rev* 2010;12:CD002893.
56. Wilson DR, Lima MT, Durham SR. Sublingual immunotherapy for allergic rhinitis: systematic review and meta-analysis. *Allergy* 2005; 60:4–12.
57. Mempel M, Rakoski J, Ring J, Ollert M. Severe anaphylaxis to kiwi fruit: immunologic changes related to successful sublingual allergen immunotherapy. *J Allergy Clin Immunol* 2003;111:1406–9.
58. Kerzl R, Simonowa A, Ring J, Ollert M, Mempel M. Life-threatening anaphylaxis to kiwi fruit: protective sublingual allergen immunotherapy effect persists even after discontinuation. *J Allergy Clin Immunol* 2007;119:507–8.
59. Enrique E, Pineda F, Malek T, Bartra J, Basagana M, Tella R, et al. Sublingual immunotherapy for hazelnut food allergy: a randomized, double-blind, placebo-controlled study with a standardized hazelnut extract. *J Allergy Clin Immunol* 2005;116:1073–9.
60. Fernandez-Rivas M, Garrido Fernandez S, Nadal JA, Alonso Diaz de Durana MD, Garcia BE, Gonzalez-Mancebo E, et al. Randomized double-blind, placebo-controlled trial of sublingual immunotherapy with a Pru p 3 quantified peach extract. *Allergy* 2009;64:876–83.
61. de Boissieu D, Dupont C. Sublingual immunotherapy for cow's milk protein allergy: a preliminary report. *Allergy* 2006;61:1238–9.
62. Kim EH, Bird JA, Kulis M, Laubach S, Pons L, Shreffler W, et al. Sublingual immunotherapy for peanut allergy: clinical and immunologic evidence of desensitization. *J Allergy Clin Immunol* 2011;127:640–6.
63. Fleischer DM, Burks AW, Vickery BP, Scurlock AM, Wood RA, Jones SM, et al. Sublingual immunotherapy for peanut allergy: a randomized, double-blind, placebo-controlled multicenter trial. *J Allergy Clin Immunol* 2013;131:119–127 e111–117.
64. Chin SJ, Vickery BP, Kulis MD, Kim EH, Varshney P, Steele P, et al. Sublingual versus oral immunotherapy for peanut-allergic children: a retrospective comparison. *J Allergy Clin Immunol* 2013;132:476–478 e472.
65. Senti G, Graf N, Haug S, Rudei N, von Moos S, Sonderegger T, et al. Epicutaneous allergen administration as a novel method of allergen-specific immunotherapy. *J Allergy Clin Immunol* 2009;124:997–1002.
66. Benhamou PH, Diszeghy V, Puteaux E, Ligouis M, Dhelft V, Plaquet C, et al. Long-term protection against new sensitization after milk-EPIT in mice sensitized to milk is mediated by Tregs [abstract]. *J Allergy Clin Immunol* 2014;133(Suppl.):AB47.
67. Dioszeghy V, Mondoulet L, Dhelft V, Ligouis M, Puteaux E, Benhamou PH, et al. Epicutaneous immunotherapy results in rapid allergen uptake by dendritic cells through intact skin and downregulates the allergen-specific response in sensitized mice. *J Immunol* 2011;186:5629–37.
68. Dioszeghy V, Mondoulet L, Dhelft V, Ligouis M, Puteaux E, Plaquet C, et al. Epicutaneous immunotherapy-induced regulatory T cells could migrate to more various sites of allergen exposure compared to sublingual or subcutaneous immunotherapy in mice sensitized to peanut [abstract]. *J Allergy Clin Immunol* 2014;133(Suppl.):AB48.
69. Novak N, Gros E, Bieber T, Allam JP. Human skin and oral mucosal dendritic cells as 'good guys' and 'bad guys' in allergic immune responses. *Clin Exp Immunol* 2010;161: 28–33.
70. Mondoulet L, Dioszeghy V, Ligouis M, Dhelft V, Dupont C, Benhamou PH. Epicutaneous immunotherapy on intact skin using a new delivery system in a murine model of allergy. *Clin Exp Allergy* 2010;40:659–67.
71. Mondoulet L, Dioszeghy V, Puteaux E, Ligouis M, Dhelft V, Letourneur F, et al. Intact skin and not stripped skin is crucial for the safety and efficacy of peanut epicutaneous immunotherapy (EPIT) in mice. *Clin Transl Allergy* 2012;2:22.
72. Dioszeghy V, Mondoulet L, Dhelft V. Protection from oral peanut-induced esophageal lesions in sensitized mice treated by epicutaneous immunotherapy is mediated by CD25+CD4+Tregs [abstract]. *J Allergy Clin Immunol* 2012;129:AB114.
73. Dioszeghy V, Mondoulet L, Dhelft V. Long-term maintenance of regulatory T cells induced by specific epicutaneous vs sublingual immunotherapy in mice sensitized to peanut [abstract]. *J Allergy Clin Immunol* 2013;68:S97.
74. Dupont C, Kalach N, Soulaïnes P, Legouë-Morillon S, Piloquet H, Benhamou PH. Cow's milk epicutaneous immunotherapy in children: a pilot trial of safety, acceptability, and impact on allergic reactivity. *J Allergy Clin Immunol* 2010;125:1165–7.
75. Agbotounoi W, Martin L, Dupont D, Pascal I, Vauleon C, Benhamou P. Epicutaneous immunotherapy (EPIT) is safe for the treatment of peanut allergy in allergic patients [abstract]. *J Allergy Clin Immunol* 2012;131:AB91.
76. Dupont C, Bourrier T, de Blay F, Guenard-Bilbault L, Sauvage C, Cousin MO, et al. Peanut epicutaneous immunotherapy (EPIT) in peanut-allergic children: 18 months treatment in the ARACHILD Study [abstract]. *J Allergy Clin Immunol* 2014;133(Suppl.):AB102.
77. Oyoshi MK, Oettgen HC, Chatila TA, Geha RS, Bryce PJ. Food allergy: insights into etiology, prevention, and treatment provided by murine models. *J Allergy Clin Immunol* 2014;133: 309–17.
78. Li XM, Srivastava K, Grishin A, Huang CK, Schofield B, Burks W, et al. Persistent protective effect of heat-killed *Escherichia coli* producing 'engineered,' recombinant peanut proteins in a murine model of peanut allergy. *J Allergy Clin Immunol* 2003;112:159–67.
79. Li XM, Srivastava K, Huleatt JW, Bottomly K, Burks AW, Sampson HA. Engineered recombinant peanut protein and heat-killed *Listeria monocytogenes* coadministration protects against peanut-induced anaphylaxis in a murine model. *J Immunol* 2003;170:3289–95.
80. Wood RA, Sicherer SH, Burks AW, Grishin A, Henning AK, Lindblad R, et al. A phase I study of heat/phenol-killed, *E. coli*-encapsulated, recombinant modified peanut proteins Ara h 1, Ara h 2, and Ara h 3 (EMP-123) for the treatment of peanut allergy. *Allergy* 2013;68: 803–8.
81. Nowak-Węgrzyn A, Sampson HA. Future therapies for food allergies. *J Allergy Clin Immunol* 2011;127:558–73.
82. Casale TB, Busse WW, Kline JN, Ballas ZK, Moss MH, Townley RG, et al. Omalizumab pretreatment decreases acute reactions after rush immunotherapy for ragweed-induced seasonal allergic rhinitis. *J Allergy Clin Immunol* 2006;117:134–40.
83. Massanari M, Nelson H, Casale T, Busse W, Kianifard F, Geba GP, et al. Effect of pretreatment with omalizumab on the tolerability of specific immunotherapy in allergic asthma. *J Allergy Clin Immunol* 2010;125:383–9.
84. Chang TW, Chen C, Lin CJ, Metz M, Church MK, Maurer M. The potential pharmacologic mechanisms of omalizumab in patients with chronic spontaneous urticaria. *J Allergy Clin Immunol* 2015;135:337–42.
85. Leung DY, Sampson HA, Yunginger JW, Burks AW Jr, Schneider LC, Wortel CH, et al. Effect of anti-IgE therapy in patients with peanut allergy. *N Engl J Med* 2003;348: 986–93.
86. Sampson HA, Leung DY, Burks AW, Lack G, Bahna SL, Jones SM, et al. A phase II, randomized, double-blind, parallelgroup, placebo-controlled oral food challenge trial of Xolair (omalizumab) in peanut allergy. *J Allergy Clin Immunol* 2011;127:1309–10.
87. Dullaers M, De Bruyne R, Ramadani F, Gould HJ, Gevaert P, Lambrecht BN. The who, where, and when of IgE in allergic airway disease. *J Allergy Clin Immunol* 2012;129:635–45.

88. Eggel A, Baravalle G, Hobi G, Kim B, Buschor P, Forrer P, et al. Accelerated dissociation of IgE-FcεpsilonRI complexes by disruptive inhibitors actively desensitizes allergic effector cells. *J Allergy Clin Immunol* 2014;133:1709–1719 e1708.
89. Li XM, Brown L. Efficacy and mechanisms of action of traditional Chinese medicines for treating asthma and allergy. *J Allergy Clin Immunol* 2009;123:297–306.
90. Wang J, Patil SP, Yang N, Ko J, Lee J, Noone S, et al. Safety, tolerability, and immunologic effects of a food allergy herbal formula in food allergic individuals: a randomized, double-blinded, placebo-controlled, dose escalation, phase I study. *Ann Allergy Asthma Immunol* 2010;105:75–84.
91. Ross J, Carlisle S, Vazquez M, Jones S, Pongracic J, Wang J. Food Allergy Herbal Formula-2 (FAHF-2) – adherence to treatment. *J Allergy Clin Immunol* 2014;133:AB403.
92. Huang YJ, Nelson CE, Brodie EL, Desantis TZ, Baek MS, Liu J, et al. Airway microbiota and bronchial hyperresponsiveness in patients with suboptimally controlled asthma. *J Allergy Clin Immunol* 2011;127:372–381 e371–373.
93. Kong HH, Oh J, Deming C, Conlan S, Grice EA, Beatson MA, et al. Temporal shifts in the skin microbiome associated with disease flares and treatment in children with atopic dermatitis. *Genome Res* 2012;22:850–9.
94. Noval Rivas M, Burton OT, Wise P, Zhang YQ, Hobson SA, Garcia Lloret M, et al. A microbiota signature associated with experimental food allergy promotes allergic sensitization and anaphylaxis. *J Allergy Clin Immunol* 2013;131:201–12.
95. West CE, Jenmalm MC, Prescott SL. The gut microbiota and its role in the development of allergic disease: a wider perspective. *Clin Exp Allergy* 2015;45:43–53.
96. Prescott SL, Bjorksten B. Probiotics for the prevention or treatment of allergic diseases. *J Allergy Clin Immunol* 2007;120:255–62.
97. Moingeon P. Adjuvants for allergy vaccines. *Hum Vaccin Immunother* 2012;8:1492–8.
98. Pfaar O, Barth C, Jaschke C, Hormann K, Klimek L. Sublingual allergen-specific immunotherapy adjuvanted with monophosphoryl lipid A: a phase I/IIa study. *Int Arch Allergy Immunol* 2011;154:336–44.
99. Treanor JJ, Essink B, Hull S, Reed S, Izikson R, Patriarca P, et al. Evaluation of safety and immunogenicity of recombinant influenza hemagglutinin (H5/Indonesia/05/2005) formulated with and without a stable oil-in-water emulsion containing glucopyranosyl-lipid A (SE+GLA) adjuvant. *Vaccine* 2013;31:5760–5.
100. Syed S, Zubair A, Frieri M. Immune response to nanomaterials: implications for medicine and literature review. *Curr Allergy Asthma Rep* 2013;13:50–7.
101. Hiraide E, Nakajima-Adachi H, Hachimura S. Oral administration of T cell epitope peptide inhibits the systemic IL-4 response elicited by an egg-white diet in a TCR transgenic mouse model. *Bioscience Microbiota Food Health* 2014;33:47–51.
102. Rupa P, Mine Y. Oral immunotherapy with immunodominant T-cell epitope peptides alleviates allergic reactions in a Balb/c mouse model of egg allergy. *Allergy* 2012;67:74–82.

# Role of Barrier Dysfunction and Immune Response in Atopic Dermatitis

NATALIJA NOVAK | DONALD Y.M. LEUNG

## KEY POINTS

- Pruritus and chronic or relapsing eczematous dermatitis with typical distribution are essential for diagnosis of atopic dermatitis (AD).
- Interactions between susceptibility genes, the host's environment, pharmacologic abnormalities and immunologic factors contribute to the pathogenesis of AD.
- Recent genome-wide association studies have confirmed the association of single-nucleotide polymorphisms (SNPs) of loci of the epidermal differentiation complex (EDC) with AD.
- Bacterial and viral antigens as well as allergens and autoantigens play a role in the pathogenesis of AD.

Atopic dermatitis is a highly pruritic chronic inflammatory skin disease that commonly presents during early childhood.<sup>1</sup> It is frequently associated with a personal or family history of respiratory allergy, i.e. allergic asthma and/or rhinitis, and can have profound effects on patients' lives, career choices and social interactions. Recent interest in AD has been sparked by reports of its increasing prevalence.<sup>2</sup> Management approaches in AD have evolved from our rapidly increased understanding of the mechanisms underlying this skin disease and novel therapeutic avenues.

## Epidemiology

Atopic dermatitis is a common skin disease with a lifetime prevalence in children of 10% to 20% in the USA, Northern and Western Europe, Japan, and other westernized countries. Environmental factors are critical in determining disease expression. Some of the potential risk factors that have received attention as being associated with the rise in atopic disease include small family size, increased income and education both in whites and blacks, migration from rural to urban environments, and increased use of antibiotics, that is, the so-called 'western lifestyle'. These observations are supported by observations that allergic responses are driven by T helper cell type 2 (Th2) immune responses, whereas infections are induced by Th1 responses. Since Th1 responses antagonize the development of Th2 cells, a decreased number of infections or the lack of Th1 signals during early childhood could predispose to Th2 allergic responses (see Chapters 1 and 2).

## Diagnosis and Differential Diagnosis

Clinical features of AD are listed in [Box 50-1](#). Of the major features, pruritus and chronic or relapsing eczematous dermatitis with typical distribution are essential for diagnosis.<sup>3</sup> Intense pruritus and cutaneous reactivity are cardinal features of AD. Pruritus may be intermittent throughout the day but is usually worse at night. Its consequences are scratching, prurigo papules, lichenification and eczematous skin lesions. Patients with AD have a reduced threshold for pruritus. As a result, allergens, reduced humidity, excessive sweating and low concentrations of irritants (e.g. wool, acrylic, soaps and detergents) can exacerbate itching and scratching.

During infancy AD is generally more acute with excoriation, vesicles over erythematous skin and serous exudate. The rash primarily involves the face, scalp and extensor surfaces of the extremities ([Figure 50-1](#)). In the patient with chronic AD, skin lesions become lichenified ([Figure 50-2](#)) and the rash localizes to the flexural folds of the extremities. Approximately half of children with AD continue to have persistent skin disease as adults. At all stages of AD, patients usually have dry, lackluster skin. Chronic hand eczema, the most common form of occupational skin disease, may be the primary manifestation in many adults with AD. Other features, including exogenous allergy or elevated IgE, are variable although commonly seen in AD.

[Box 51-1](#) lists a number of inflammatory skin diseases, immunodeficiencies, skin malignancies, metabolic disorders, and infectious diseases that share features of AD. The differential diagnosis of AD should be considered particularly in patients with refractory AD. Infants presenting in the first year of life with failure to thrive, diarrhea, a generalized scaling erythematous rash and recurrent cutaneous and/or systemic infections should be evaluated for severe combined immunodeficiency syndrome (see Chapter 9). Wiskott-Aldrich syndrome is an X-linked recessive disorder characterized by thrombocytopenia, defects in humoral and cellular immunity and recurrent bacterial infections. The hyperimmunoglobulin E (hyper-IgE) syndrome is characterized by elevated serum IgE levels, defective T and B cell function, recurrent deep-seated bacterial infections including cutaneous abscesses caused by *Staphylococcus aureus* and/or pruritic skin disease caused by *S. aureus*, such as pustulosis, or recalcitrant dermatophytosis, reported with human immunodeficiency virus as well as with a variety of infestations such as scabies. Dock8 deficiency should be considered in patients with severe recurrent eczema herpeticum. Other conditions that can be confused with AD include psoriasis, ichthyosis, and seborrheic dermatitis.





**Figure 50-1** Infant with acute atopic dermatitis. Note the oozing and crusting skin lesions. (Reproduced with permission from Weston WL, Morelli JG, Lane A, editors. *Color textbook of pediatric dermatology*. 3rd ed. St Louis: Mosby; 2002.)

### BOX 50-1 CLINICAL FEATURES OF ATOPIC DERMATITIS\*

#### ESSENTIAL FEATURES

- Pruritus
- Facial and extensor eczema in infants and children
- Flexural eczema in adults
- Chronic or relapsing dermatitis

#### FREQUENTLY ASSOCIATED FEATURES

- Personal or family history of atopic disease
- Xerosis
- Cutaneous infections
- Nonspecific dermatitis of the hands or feet
- Elevated serum IgE levels
- Positive immediate-type allergy skin tests
- Early age of onset

#### OTHER FEATURES

- Ichthyosis, palmar hyperlinearity, keratosis pilaris
- Pityriasis alba
- Nipple eczema
- White dermatographism and delayed blanch response
- Anterior subcapsular cataracts, keratoconus
- Dennie-Morgan infraorbital folds, orbital darkening
- Facial erythema or pallor
- Perifollicular accentuation

\*Other skin conditions that may mimic atopic dermatitis should be excluded (see Box 51-1).

Adolescents or adults who present with an eczematous dermatitis with no history of childhood eczema, respiratory allergy or atopic family history may have allergic contact dermatitis (see Chapter 53). Of note, topical glucocorticoid contact allergy has been reported increasingly in patients with chronic dermatitis on topical corticosteroid therapy.

## Pathogenesis

Interactions between susceptibility genes, the host's environment, pharmacologic abnormalities and immunologic factors contribute to the pathogenesis of AD. There are two disease models: first, that AD is a skin disease that primarily derives from an intrinsic defect of epithelial cells and skin

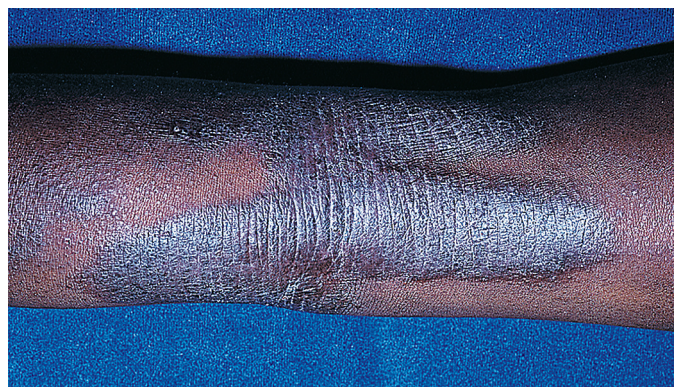

**Figure 50-2** Adolescent with lichenification of the popliteal fossa from chronic atopic dermatitis. (Reproduced with permission from Weston WL, Morelli JG, Lane A, editors. *Color textbook of pediatric dermatology*. 3rd ed. St Louis: Mosby; 2002.)

barrier, thereby facilitating as a second step numerous modifications of innate and adaptive immunity (the outside-inside hypothesis); second, that AD is primarily an immunologic disease with mechanisms related to the overactivation of the immune system and Th2 dominated immune responses that impact secondarily on skin barrier function (the inside-outside hypothesis).<sup>4</sup> However, it is most likely that a combination of both hypotheses and a continuous interplay contributes to the complexity of AD.

## Genetics

The fact that AD and atopic disorders frequently affect more than one family member accounts for the strong genetic background of this disease. Several genetic factors contribute to the complex pathophysiology of AD, indicating that it is not a monogenic but a genetically complex disorder.<sup>5,6</sup> It seems most likely that not only AD itself but, in particular, different subtypes of AD such as AD with early onset, childhood AD versus adulthood AD or AD with IgE mediated allergic reactions might be based on distinct genetic constellations.<sup>7-9</sup> Therefore, one approach to achieve clarity could be systematic distinction of genetic modifications associated with (1) skin barrier dysfunction, (2) deficient innate immune responses and (3) modified adaptive immune reactions in AD.<sup>10,11</sup>

## GENETICS AND SKIN BARRIER DYSFUNCTION

Dry skin, mirrored by increased transepidermal water loss, reduced skin hydration and decreased amounts of natural moisturizing factor indicate skin barrier impairment in AD.<sup>12,13</sup> A candidate gene region for AD, localized on chromosome 1q21,<sup>5</sup> contains a selection of genes encoding structural proteins of epidermal cornification, such as S100A proteins, profilaggrin, small proline-rich region proteins (SPRRs) and late envelope proteins (LEP), which form the so-called 'epidermal differentiation complex' (EDC). Filaggrin is an essential protein in maintenance of the formation of the stratum corneum barrier.<sup>14</sup> In recent years, loss-of function mutations in the filaggrin gene have been shown to be strongly associated with AD.<sup>15</sup> This finding was replicated and confirmed by an impressive series of independent studies.<sup>16,17</sup> Moreover, a closer look at the filaggrin loss-of-function carriers within the group of AD



patients revealed that specific clinical features and subtypes of AD are highly associated, including AD with early onset and a high number of allergen sensitizations. Moreover, specific interactions between genetic predisposition and environmental factors such as cat exposure at the time of birth seem to increase the risk for manifestations of eczema during the first year of life, in particular in children with filaggrin mutations.<sup>18</sup> In addition, in the context of a genetically determined disturbed skin barrier in AD, there are reports of associations of polymorphisms in the *SPINK5* gene, which encodes the lymphoepithelial kazal-type related inhibitor (LEKTI), an inhibitor of serine proteases. Other studies have reported on the association with AD of genetic modifications in the gene region encoding the stratum corneum chymotryptic enzyme (SCCE), leading to impaired stratum corneum integrity and function.<sup>19</sup> Studies have also reported on gene associations with other epidermal components, such as collagen 29 (COL29),<sup>20</sup> or a genetic variant on chromosome. In addition to these genetically predetermined factors, highly active endogenous proteases such as mast cell chymase (MCC), as well as exogenous proteases derived from house dust mite allergens or *S. aureus*, cleave corneodesmosomes and accelerate desquamation of corneocytes.<sup>21</sup> They may also delay epithelial regeneration by binding proteinase-activated receptors (PAR)-2 and thereby contribute to skin barrier impairment in AD.<sup>22</sup> Recent genome-wide association studies have confirmed the association of SNPs of loci of the EDC with AD.<sup>23,24</sup> As well as from these genetic changes, epigenetic modifications have been demonstrated in lesional skin of AD patients and are another putative factor impacting on epidermal skin barrier function.<sup>25</sup>

## GENETICS AND INNATE IMMUNITY

First-line host defense mechanisms of the innate immune system are maintained by pattern-recognition receptors (PRR) that sense the environment for invading pathogens. Toll-like receptors (TLR), intracellular nucleotide-binding oligomerization domain (NOD) proteins and the LPS receptor CD14<sup>26,27</sup> belong to the PRRs and discriminate between diverse pathogen associated molecular patterns. Deficient maturation of the immune system and decreased efficiency in responding to PRR stimulation are suspected to account not only for higher prevalence of atopy but also the greatly increased propensity of AD patients to microbial infections. Several studies have focussed on a putative association between variations within gene regions encoding components of the innate immune system and AD. A polymorphism within the *TLR2* gene has been shown to be associated with severe forms of AD with recurrent bacterial infections<sup>28</sup> and has been linked to functional modifications of *TLR2*.<sup>29</sup> However, no association of polymorphisms in the *TLR2*, *TLR4* and *TLR6* genes with AD could be shown in other studies.<sup>30,31</sup> A polymorphism in the *TLR9* gene of putative functional relevance on *TLR9* promoter activity was associated with pure AD.<sup>32</sup>

SNPs within five known loci (1q21.3 [*LCE3A*], 5q31.1 [*IL13*, *KIF3A*, *SLC22A4*], 11q13.5 [*C11orf30*] and 20q13.33 [*TNFRSF6B*]) as well as four new loci (4q27 [*IL2*, *IL21*], 11p13 [*PRR5L*], 16p3 [*CLEC16A*] and 17q21.32 [*TNFRSF6B*]) were detected in genome-wide study thresholds for association with AD in a recent study.<sup>23</sup> Moreover, 36 SNPs within three chromosomal regions, i.e. 2q12, 6p21 and 11p15.4, were significantly associated with AD in another study.<sup>24</sup>

## GENETICS AND ADAPTIVE IMMUNITY

Induction of different receptors on effector cells, dendritic cells or other cells after passage of allergens and microbial pathogens into the skin contributes to numerous other mechanisms involving the adaptive immune system. To date, a wide repertoire of genetic modifications of gene regions encoding components of adaptive immunity has been associated with AD.<sup>6,33,34</sup> Soluble factors such as cytokines and chemokines, which play a crucial role as soluble mediators of the adaptive immune system, show profound variations in AD, and it is more than likely that some of these deviations are already genetically encoded.<sup>35</sup> These comprise genetic variations on chromosome 5q31-33 that cover genes of the Th2 cytokine cluster such as interleukin (IL)-3, IL-4, IL-5, IL-13 and granulocyte-macrophage colony stimulating factor (GM-CSF),<sup>6,7</sup> functional mutations of the promoter region of *RANTES/CCL5* (17q11) and gain-of-function polymorphisms in the *IL4RA* gene (16q12).<sup>6,7,36</sup> Interestingly, polymorphisms in the *IL4RA* gene region were associated with AD with low IgE serum levels and no allergen sensitization. Beyond this, polymorphisms in the *IL18* gene associated with AD might contribute to modified IL-18 production of peripheral blood mononuclear cells (PBMC) of patients with AD after stimulation with microbial components.<sup>37</sup>

## SYSTEMIC IMMUNE RESPONSE

Most patients with AD have peripheral blood eosinophilia and increased serum IgE levels. Nearly 80% of children with AD develop allergic rhinitis or asthma. Serum IgE level is strongly associated with the prevalence of asthma, which suggests that allergen sensitization through the skin predisposes the patient to respiratory disease because of its effects on the systemic allergic response. Indeed, epicutaneous sensitization of mice with protein antigen induces allergic dermatitis, elevated serum IgE, airway eosinophilia and hyperresponsiveness to methacholine. This suggests that epicutaneous exposure to allergen in AD enhances the development of allergic asthma.

An increased frequency of skin-homing T cells producing IL-4, IL-5 and IL-13 but little interferon (IFN)- $\gamma$  has been found in the peripheral blood of patients with AD. There is evidence that this predominance of Th2 cells results partially from selective apoptosis of circulating memory/effector Th1 cells. These immunologic alterations are important because IL-4 and IL-13 are the only cytokines that induce germline transcription at the  $C_{\epsilon}$  exon, thereby promoting isotype switching to IgE. IL-4 and IL-13 also induce the expression of vascular adhesion molecules, such as vascular cell adhesion molecule-1 involved in eosinophil infiltration, and down-regulate Th1-type cytokine activity. IL-5 plays a key role in the development, activation and cell survival of eosinophils. In contrast, IFN- $\gamma$  inhibits IgE synthesis as well as the proliferation of Th2 cells and expression of the IL-4 receptor on T cells. The decreased IFN- $\gamma$  produced by T cells from AD patients may be the result of reduced production of IL-18. Furthermore, an inverse relationship between skin colonization with *S. aureus* and spontaneous IFN- $\gamma$  production of CD4<sup>+</sup> T cells as well as induced IFN- $\gamma$  production of CD8<sup>+</sup> T cells has been observed.<sup>38</sup>

A number of determinants support Th2 cell development in AD. These include the cytokine milieu in which T cell development is taking place, pharmacologic factors, the costimulatory signals used during T cell activation, and the antigen-presenting

cells (APCs). In this regard, IL-4 promotes Th2 cell development, whereas IL-12, produced by macrophages, dendritic cells or eosinophils, induces Th1 cells. Mononuclear cells from patients with AD have increased cyclic adenosine monophosphate (cAMP)-phosphodiesterase (PDE) enzyme activity. This cellular abnormality contributes to the increased IgE synthesis by B cells and IL-4 production by T cells in AD as IgE and IL-4 production is decreased in vitro by PDE inhibitors.

## SKIN IMMUNOPATHOLOGY

### Pathology

Clinically unaffected skin of AD patients exhibits mild epidermal hyperplasia and a sparse perivascular T cell infiltrate. Furthermore, increased transepidermal water loss and reduced skin hydration is detectable even in nonlesional AD skin.<sup>39</sup> AD has a biphasic nature, characterized by an acute phase, which is predominated by Th2 cytokines, followed by a chronic phase, featuring Th1 cytokines.<sup>40</sup> Acute eczematous skin lesions are characterized by marked intercellular edema (spongiosis) of the epidermis. Dendritic APCs such as Langerhans cells (LCs) and macrophages in lesional and, to a lesser extent, in nonlesional skin of AD patients have surface-bound IgE molecules. Within 24 to 48 hours after allergen application rapid influx of IgE-receptor bearing inflammatory dendritic epidermal cells (IDEC) and up-regulation of FcεRI expression are detectable in the epidermis of atopy patch test lesions.<sup>41</sup> In the dermis of the acute lesion there is a marked perivascular T cell infiltrate with occasional monocyte-macrophages. The critical role of T cells in AD is suggested by the obligate role of T cells in mouse models of AD. The lymphocytic infiltrate consists predominantly of activated memory T cells bearing CD3, CD4 and CD45RO. Eosinophils, basophils and neutrophils are rarely present in acute AD; mast cells are found in normal numbers but in various stages of degranulation. There is an increase in *S100A7*, *S100A8* and *S100A9* gene expression together with activation of Th2 and Th22 cytokines during the acute phase of AD.<sup>42</sup>

Chronic lichenified lesions are characterized by a hyperplastic epidermis with elongation of the rete ridges and prominent hyperkeratosis. There is an increased number of IgE-bearing DCs in the epidermis, and macrophages dominate the dermal mononuclear cell infiltrate. Mast cells are increased in number. Increased numbers of eosinophils are observed in chronic AD skin lesions. Eosinophils secrete cytokines and mediators that augment allergic inflammation and induce tissue injury in AD through the production of reactive oxygen intermediates and release of toxic granule proteins.

After topical treatment with calcineurin inhibitors, there is a decreased number of infiltrating T cells, B cells and eosinophils as well as expression of Th2 cytokines in addition to frequency of CD8<sup>+</sup> T cells expressing the Th1 cytokine IFN-γ has been observed.<sup>43,44</sup> Later on, surface expression of FcεRI epidermal DCs and number of epidermal inflammatory DC subtypes decreased, while frequency of LCs increased.

### Cytokine Expression

Th2- and Th1-type cytokines contribute to the pathogenesis of skin inflammation in AD. As compared with the skin of normal controls, unaffected skin of AD patients has an increased number of cells expressing IL-4 and IL-13, but not IL-5, IL-12, or IFN-γ, mRNA. Acute and chronic skin lesions, when compared to normal skin or uninvolved skin of AD patients, have

significantly greater numbers of cells that are positive for IL-4, IL-5 and IL-13 mRNA. However, acute AD is not characterized by significant expression of IFN-γ or IL-12.

Chronic AD skin lesions have significantly fewer IL-4 and IL-13 mRNA-expressing cells, but greater numbers of IL-5, granulocyte-macrophage colony-stimulating factor (GM-CSF), IL-12 and IFN-γ mRNA-expressing cells than acute AD. IL-5 and GM-CSF probably contribute to the increased numbers of eosinophils and macrophages. The increased expression of IL-12 in chronic AD skin lesions is of interest in that cytokine plays a key role in IFN-γ induction. Its expression in eosinophils and/or macrophages may initiate the switch to Th1 or Th0 cell development in chronic AD.

Aside from Th2 cytokines, elevated expression of Th22 cytokines has been observed in AD skin<sup>42,45</sup> and small numbers of IL-17<sup>+</sup> cells have been demonstrated to infiltrate the dermis of AD skin lesions.<sup>46,47</sup> Higher mRNA expression of Th17 and Th22 cytokines has been observed in intrinsic AD as compared to extrinsic AD. Severity score of AD positively correlated with mRNA expression of Th2 cytokines in the skin and negatively correlated with expression of barrier proteins.

Activated T cells infiltrating the skin of AD patients have also been found to induce keratinocyte apoptosis, which contributes to the spongiotic process found in AD skin lesions. This process is mediated by IFN-γ, which up-regulates *Fas* on keratinocytes. The lethal hit is delivered to keratinocytes by *Fas*-ligand expressed on the surface of T cells that invade the epidermis and soluble *Fas*-ligand released from T cells. Additionally, there is some evidence that caspase-3 cleavage in the spinous epidermal layer also contributes to spongiosis.<sup>48</sup> Mechanisms of IFN-γ induced keratinocyte apoptosis in AD have been analyzed in more detail and three apoptosis-related genes (*NOD2*, *DUSP1* and *ADM*) and eight genes overexpressed in AD skin lesions (*CCDC109B*, *CCL5*, *CCL8*, *IFI35*, *LYN*, *RAB31*, *IFITM1* and *IFITM2*) have been identified as playing a key role in this process.<sup>49</sup>

Another factor inducing keratinocyte cell death is alpha toxin released by *S. aureus*. The amount of the enzyme acid sphingomyelinase, which is capable of preventing Th2 mediated increase of alpha toxin induced cell death, is reduced in AD skin.<sup>50</sup> Additionally, it has been demonstrated that filaggrin is able to inhibit *S. aureus* alpha toxin mediated keratinocyte cell death.<sup>51</sup> Together these data provide evidence for increased keratinocyte cell death in AD due to lower filaggrin expression and the increased Th2 microenvironment in the skin.

The role of regulatory T cell subtypes in AD is still unclear. There is some evidence for functional deficiency of resident T<sub>REG</sub> cells in the skin,<sup>52</sup> while other studies report increased local numbers of CD4<sup>+</sup>CD25<sup>+</sup>Foxp3<sup>+</sup> T<sub>REG</sub> cells in patients with AD. In addition, it has been demonstrated that activated CD25-expressing T cells with a phenotype of regulatory T cells, lacking CCR6 expression, promote Th2 immune responses in patients with AD.<sup>53</sup> However, additional studies are required to elucidate the role of T<sub>REG</sub> cells in AD.

### Antigen-Presenting Cells

Atopic dermatitis skin contains an increased number of IgE-bearing LCs, which appear to play an important role in cutaneous allergen presentation to Th2 cells.<sup>54</sup> Binding of IgE to LCs occurs primarily via high-affinity IgE receptors. The clinical importance of these IgE receptors on LCs is supported by the observation that the presence of FcεRI-expressing LCs bearing

IgE molecules is required to provoke eczematous skin lesions by application of aeroallergens on uninvolved skin of AD patients. In contrast to mast cells and basophils where the FcεRI is a tetrameric structure constitutively expressed at high levels, this receptor on APCs consists of the α-chain, which binds IgE and γ-chain dimers containing an immunoreceptor tyrosine-based activation motif (ITAM) for downstream signaling, but lacks the classic β-chain.<sup>55</sup> It is assumed that allergens which invade the skin are taken up by IgE molecules bound to FcεRI-expressing DCs. In the epidermis, FcεRI expression on DCs is related to the atopic state of the individual, with higher expression in AD lesions as compared to nonlesional skin of AD patients or epidermal skin of nonatopic individuals. Different FcεRI-bearing DC subtypes have been identified in lesional AD skin. CD207<sup>+</sup>/CD1a<sup>+</sup>, i.e. LCs, as well as CD207<sup>+</sup>/CD1a<sup>+</sup>/FcεRI<sup>+</sup> DCs are located in the epidermis. CD1c<sup>+</sup>/FcεRI<sup>+</sup> DCs represent the major DC subpopulation of the dermal compartment, while low numbers of CD207<sup>+</sup>/FcεRI<sup>+</sup>/CD1a<sup>+</sup> DCs are also detectable in the dermis.<sup>56</sup>

Furthermore it has been demonstrated that the ability of cutaneous DC subsets to prime Th1, Th2, Th17 and Th22 immune responses *in vitro* is the same for DC derived from skin lesions of patients with AD or patients with other inflammatory skin diseases such as psoriasis. This indicates that chemokine expression and release together with other soluble and cellular factors of the skin micromilieu might be crucial for the outcome of T cell responses and disease-specific T cell responses in the skin.<sup>57</sup>

Besides myeloid DCs, macrophage-like cells with high histamine receptor 1 expression are detectable in the dermis of lesional AD skin and might amplify inflammation after stimulation with histamine released by mast cells and other cells.<sup>58</sup>

### MYELOID DENDRITIC CELLS (MDC) CONTRIBUTE TO ALLERGIC SENSITIZATION AND MAINTENANCE OF INFLAMMATION WITH TH2-TH1 SWITCH

Langerhans cells bearing FcεRI are the main myeloid DC population present in nonlesional AD skin; upon allergen challenge and inflammation, FcεRI bearing myeloid DCs, so-called 'inflammatory dendritic epidermal cells (IDECs)' are detectable in the epidermis. After IgE binding and internalization of the allergen, LCs migrate to peripheral lymph nodes and present the processed allergen efficiently to naïve T cells, thus initiating a Th2 immune response with sensitization to the antigen. Beyond, the activated LCs can present the allergen-derived peptides locally to transiting antigen-specific T cells and induce a T cell mediated secondary immune response. Concomitantly, aggregation of FcεRI on the surface of LCs *in vitro* promotes the release of chemotactic factors, which *in vivo* supposedly contribute to the recruitment of IDECs into the epidermis. IDECs mainly present at inflammatory sites, produce high amounts of proinflammatory cytokines after FcεRI cross-linking, display a high stimulatory capacity toward T cells and serve as amplifiers of the allergic inflammatory immune response.<sup>59</sup> Moreover, stimulation of FcεRI on the surface of IDECs induces the release of IL-12 and IL-18 and enhances the priming of naïve T cells into IFN-γ producing Th1 or Th0 cells. These mechanisms may contribute to the switch from the initial Th2 immune response in the acute phase to the Th1 immune responses in the chronic phase.<sup>59</sup>

Precursor cells of myeloid DCs display lower responsiveness to TGF-β, which might contribute to a lower number of LCs in favor of higher numbers of DCs with inflammatory properties differentiating from precursor cells.<sup>60</sup> Additionally, DCs and precursor cells of DCs of patients with AD show an attenuated response to IFN-γ stimulation, which in part results from a lower expression of IFN-γRI and IFN-γRII, leading to lower phosphorylation of STAT-1 and lower expression of IFN-γ inducible genes. Together this reduced IFN-γ response might contribute to the overbalance of the Th2 immune response in the acute phase of AD.<sup>61</sup>

### PLASMACYTOID DENDRITIC CELLS

Human plasmacytoid DCs (PDCs) are the only professional interferon (IFN) producing cells and express the IL-3 receptor α-chain (CD123) and the blood dendritic cell antigen (BDCA)-2.<sup>62</sup> Stimulation of PDCs with viral antigens induces the production of IFN-α/β, which is of crucial importance for the defense against viral infections. Human PDCs bear the PRRs TLR7 and TLR9 on their cell surface. Furthermore, they express the high-affinity receptor for IgE (FcεRI).<sup>63,64</sup> Based on a close interaction of FcεRI with TLR9, the amount of IFN-α and IFN-β released in response to TLR9 stimulation is profoundly down-regulated in PDCs after FcεRI aggregation and allergen challenge *in vitro*.<sup>63,65,66</sup> In view of frequent FcεRI aggregation induced by allergen challenge of PDCs of AD patients, this counterregulation might account for a profoundly reduced release of IFNs after viral antigen stimulation.

Furthermore, as compared to psoriasis, contact dermatitis or lupus erythematosus, the frequency of PDCs in the lesional epidermal skin of AD is low, although PDCs are recruited to the dermis during atopy patch test (APT).<sup>40</sup> This might result from Th2 cytokines or IL-10 in the skin micromilieu, leading to apoptosis of PDCs and, together with the counterregulation of FcεRI with TLRs, promote enhanced susceptibility of AD patients to viral skin infections.

### Inflammatory Cell Infiltration

Several chemokines have been linked to recruitment of inflammatory cell subtypes such as DCs, T cells eosinophils, etc. to the skin in AD, including CCL2, CCL3, CCL4, CCL5, CCL11, CCL13, CCL18, CCL20, CCL22, CCL26 and CCL27.<sup>67</sup> Moreover, serum levels of some of these chemokines correlate directly with disease activity<sup>67</sup> and decrease in response to successful topical treatment, as shown for CCL5 and CCL11 after tacrolimus treatment.<sup>68</sup> A role of CCL18 in the amplification of allergic inflammation by increased homing of memory T cells has been demonstrated.<sup>69,70</sup> Another chemokine shown to be selectively up-regulated in AD was CCL1, the ligand to C-C chemokine receptor (CCR)8, which *in vitro* promoted the recruitment of T cells and Langerhans cell-like DCs.<sup>71</sup> IL-16, a chemoattractant for CD4<sup>+</sup> T cells, is increased in acute AD skin lesions. The C-C chemokines, RANTES/CCL5, monocyte chemoattractant protein-4 (MCP-4/CCL13) and eotaxin/CCL11 have also been found to be increased in AD skin lesions and likely contribute to the chemotaxis of eosinophils and Th2 lymphocytes into the skin.

IL-31 is a novel cytokine, preferentially expressed by Th2 cells, which signals through a heterodimeric receptor composed of IL-31 receptor A and oncostatin M receptor.<sup>72</sup> Interestingly, up-regulated IL-31 expression has been observed in pruritic AD



skin lesions<sup>73</sup> and was inducible by both stimulation of cutaneous lymphocyte antigen bearing (CLA<sup>+</sup>) T cells of AD patients with staphylococcal enterotoxin B (SEB) in vitro and application of SEB to the skin of AD patients in vivo.<sup>72-74</sup> Furthermore, IL-31 induced the expression of the inflammatory chemokines CCL1, CCL17 and CCL22 in keratinocytes.<sup>75</sup> Since IL-31 induces severe pruritus and dermatitis in transgenic mice<sup>75</sup> and IL-31 receptor showed most abundant expression in dorsal root ganglia,<sup>72</sup> these findings provide a new link between staphylococcal colonization, subsequent T cell recruitment and activation and pruritus induction in patients with AD.<sup>72</sup>

In terms of T cells infiltrating the inflamed skin, it has been suggested that the so-called 'Th17 cells' may be of relevance not only in psoriasis but also in AD. Reports from animal models combined with studies using atopy patch tests or microarrays imply that Th17 may be induced in the skin by the topical application of allergens and may therefore assist skin infection in AD. However, as compared to psoriasis, Th17 most likely plays a rather minor role in AD skin.<sup>76</sup>

### INTRINSIC DEFECT OF KERATINOCYTES IN ATOPIC DERMATITIS

Keratinocytes play an important role in the production of antimicrobial protein and cytokines in response to stimulation by invading pathogens, mediating both innate and adaptive inflammatory immune reactions. In addition, AD keratinocytes express high levels of the IL-7 like cytokine thymic stromal lymphopoietin (TSLP), which activates myeloid dendritic cells (DCs) to increase expression of IL-5, IL-13, CCL17 and CCL22. Skin-specific overexpression of TSLP in a transgenic mouse resulted in an AD-like phenotype, with the development of eczematous lesions containing inflammatory dermal cellular infiltrates, an increase in Th2 CD4<sup>+</sup> T cells expressing cutaneous homing receptors and elevated serum levels of IgE,<sup>77</sup> pointing to an important role of TSLP in AD.<sup>78</sup> DCs primed by TSLP may convert to strong inducers of T cell responses of the Th2 type in vitro,<sup>79</sup> so that enhanced TSLP release triggered by frequent allergen challenge, microbial infections and inflammation might initiate and perpetuate Th2 immune responses in AD.

#### Chronic Skin Inflammation

Chronic AD is linked to the prolonged survival of inflammatory cells in atopic skin. IL-5 expression during chronic AD plays a role in prolonging survival of eosinophils and enhancement of their function. In chronic AD, increased GM-CSF expression maintains the survival and function of monocytes, LCs and eosinophils. Epidermal keratinocytes from AD patients have significantly higher levels of RANTES expression following stimulation with tumor necrosis factor (TNF)- $\alpha$  and IFN- $\gamma$  than keratinocytes from psoriasis patients. This may serve as one mechanism by which cytokines such as TNF- $\alpha$  enhances the chronicity and severity of eczema. Mechanical trauma can also induce the release of TNF- $\alpha$  and many other proinflammatory cytokines from epidermal keratinocytes. Thus, chronic scratching plays a role in the perpetuation and elicitation of skin inflammation in AD.

#### Antimicrobial Peptides

The innate immune system provides a rapid response to invasion of microbes. Research results from recent years strongly

imply that impaired innate immune mechanisms with deficiency of the antimicrobial peptides (AMPs), which are represented by human intracellular proteins, i.e. human cathelicidin LL-37, human  $\beta$ -defensin (HBD)2 and HBD3 as well as dermcidin-derived antimicrobial proteins in sweat, might contribute to the susceptibility of AD patients to skin infections.<sup>80</sup> Defensins are broad-spectrum antibiotics that kill a wide variety of bacterial and fungal pathogens. Antimicrobial activity against viral pathogens is maintained by LL-37.<sup>81</sup> Efficient killing of *S. aureus* is achieved by LL-37 together with HBD2. Since inflammatory mediators up-regulate AMP expression, chronic inflammatory skin diseases such as psoriasis and contact dermatitis are characterized by increased amounts of AMP. Conversely, only weak up-regulation of HBD2, 3 and LL-37 is detectable in both lesional and nonlesional skin of patients with AD.<sup>82</sup> The Th2 cytokines IL-4, IL-13 and IL-10 down-regulate AMP expression in vitro and might account for low AMP in AD skin.<sup>80,83</sup> Moreover, reduced mobilization of human HBD3 accounts for defective killing of *S. aureus* in AD.<sup>84</sup> In addition to the propensity to bacterial infections due to low HBD2, 3 and LL-37 expression, cathelicidin deficiency in AD might also predispose to severe viral infections such as eczema vaccinatum caused by orthopox virus<sup>81,85</sup> and eczema herpeticum (EH).<sup>86</sup> In support of this concept, lower levels of cathelicidin are detectable in skin lesions of AD patients with one or more episodes of EH in their history as compared to AD patients without EH.<sup>85</sup> Dermcidin (DCD) is another recently discovered AMP with antibacterial and antimycotic properties and is constitutively expressed in human eccrine sweat glands. The amount of several DCD derived peptides in sweat was found to be significantly reduced in AD patients with a history of bacterial and viral infections<sup>87</sup> and is another cause of higher susceptibility of AD patients to microbial infections. Interestingly, both incubation of keratinocytes with vitamin D<sub>3</sub> in vitro, as well as treatment of AD patients with oral vitamin D<sub>3</sub>, increases cathelicidin production of keratinocytes in AD patients, pointing to a novel opportunity to improve innate immune responses in AD patients therapeutically in the near future.<sup>88-91</sup>

## Immunologic Triggers

### FOODS

Well-controlled studies have demonstrated that food allergens induce skin rashes in children with AD. Based on double-blind, placebo-controlled food challenges, approximately 40% of infants and young children with moderate to severe AD have food allergy.<sup>92,93</sup> Food allergies in AD patients exacerbate eczema and contribute to severity of skin disease in some patients whereas urticaria reactions or other noncutaneous symptoms are triggered in other patients. Removal of food allergens from the patient's diet can lead to significant clinical improvement but requires a great deal of education because most of the common allergens (e.g. egg, milk, wheat, soy and peanut) contaminate many foods and are therefore difficult to avoid.

Infants and young children with food allergy generally have positive immediate skin tests or serum IgE directed to various foods. Positive food challenges are accompanied by significant increases in plasma histamine levels and eosinophil activation. Importantly, food allergen-specific T cells have been cloned from the skin lesions of patients with AD, providing direct



evidence that foods can contribute to skin inflammation. In mouse models of AD, oral sensitization with foods results in the elicitation of eczematous skin lesions on repeat oral food challenges. In patients, however, immediate skin tests for specific allergens do not always indicate clinical sensitivity. Therefore clinically relevant food allergy must be verified by controlled food challenges or carefully investigating the effects of a food elimination diet, which is being done in the absence of other exacerbating factors.

## AEROALLERGENS

A number of well-controlled studies have demonstrated that pruritus and eczematoid skin lesions develop after intranasal or bronchial inhalation challenge with aeroallergens, but not placebo, in AD patients sensitized to inhalant allergens. Epicutaneous application of aeroallergens by patch test techniques on uninvolved atopic skin elicits eczematoid reactions in 30% to 50% of patients with AD. Positive reactions have been observed to dust mite, weeds, animal dander and molds. In contrast, patients with respiratory allergy and healthy volunteers rarely have positive allergen patch tests.

Several studies have examined whether avoidance of aeroallergens results in clinical improvement of AD. Most of these reports have involved uncontrolled trials in which patients were placed in mite-free environments, for example hospital rooms in which acaricides or impermeable mattress covers were used. Such methods have invariably led to improvement in AD. One double-blind, placebo-controlled study using a combination of effective mite-reduction measures, as compared to no treatment, in the home has reported that a reduction in house dust mites is associated with significantly greater improvement in AD.

## STAPHYLOCOCCUS AUREUS

Patients with AD have an increased tendency to develop bacterial (Figure 50-3), viral (Figure 50-4) and fungal skin infections. *S. aureus* is found in over 90% of AD skin lesions. The density of *S. aureus* on inflamed AD lesions without clinical superinfection can reach up to  $10^7$  colony-forming units per  $\text{cm}^2$  on



**Figure 50-3** Patient with atopic dermatitis who is secondarily infected with *Staphylococcus aureus*. Note multiple pustules and areas of crusting. (Reproduced with permission from Boguniewicz M, Leung DYM. Recent insights into atopic dermatitis and implications for management of infectious complications. *J Allergy Clin Immunol* 2010;125(1):4–13.)

lesional skin. Pulsed-field gel electrophoresis of *S. aureus* isolated from families of AD children showed that similar strains are detectable in parents and their children.<sup>94</sup> This finding argues for a high recolonization rate of atopic children.<sup>94</sup> The importance of *S. aureus* is supported by the observation that even AD patients without overt infection show a greater reduction in severity of skin disease when treated with a combination of antistaphylococcal antibiotics and topical corticosteroids as compared to topical corticosteroids alone.

One strategy by which *S. aureus* exacerbates or maintains skin inflammation in AD is by secreting a group of toxins known to act as superantigens, which stimulate marked activation of T cells and macrophages. The skin lesions of over half of AD patients have *S. aureus* that secrete superantigens such as enterotoxins A and B and toxic shock syndrome toxin-1. An analysis of the peripheral blood skin-homing  $\text{CLA}^+$  T cells from these patients as well as T cells in their skin lesions reveals that they have undergone expansion of the beta region of the T cell receptor variable chain consistent with superantigenic stimulation. Most AD patients make specific IgE antibodies directed against the staphylococcal superantigens found on their skin. Basophils from patients with IgE antibodies directed to superantigens release histamine on exposure to the relevant superantigen, but not in response to superantigens to which they have no specific IgE. This raises the interesting possibility that superantigens induce specific IgE in AD patients and mast cell degranulation in vivo when the superantigens penetrate their disrupted epidermal barrier. This promotes the itch-scratch cycle critical to the evolution of skin rashes in AD.

A correlation has also been found between the presence of IgE anti-superantigens and severity of AD. Utilizing a humanized murine model of skin inflammation, the combination of



**Figure 50-4** Eczema herpeticum, the primary skin manifestation of herpes simplex in atopic dermatitis. (Reproduced with permission from Boguniewicz M, Leung DYM. Recent insights into atopic dermatitis and implications for management of infectious complications. *J Allergy Clin Immunol* 2010;125(1):4–13.)

*S. aureus* superantigen plus allergen has been shown to have an additive effect in inducing skin inflammation. Superantigens can also augment allergen-specific IgE synthesis, suggesting that several mechanisms exist by which superantigens could aggravate the severity of AD.

Increased binding of *S. aureus* to AD skin is likely related to underlying atopic skin inflammation. This concept is supported by several lines of investigation. First, it has been found that treatment with topical corticosteroids or tacrolimus will reduce *S. aureus* counts on atopic skin, although they have no antibiotic actions. Second, acute inflammatory lesions have more *S. aureus* than chronic AD skin lesions or normal-looking atopic skin. Scratching likely enhances *S. aureus* binding by disturbing the skin barrier and exposing extracellular matrix molecules known to act as adhesins for *S. aureus*, for example fibronectin and collagens. Finally, in studies of *S. aureus* binding to skin lesions of mice undergoing Th1 versus Th2 inflammatory responses, bacterial binding was significantly greater at skin sites with Th2-mediated inflammation. Importantly, this increased bacterial binding did not occur in IL-4 gene knockout mice, indicating that IL-4 plays a crucial role in the enhancement of *S. aureus* binding to skin. IL-4 appears to enhance *S. aureus* binding to the skin by inducing the synthesis of fibronectin, an important *S. aureus* adhesin. Interestingly, studies of human AD have found a role for fibrinogen in the binding of *S. aureus* to atopic skin. Because acute exudative lesions likely have increased plasma-derived fibrinogen, this may provide a mechanism for further binding of *S. aureus* to acute AD lesions.

The highly increased binding of *S. aureus* to AD skin is not enough to account for the highly increased numbers of *S. aureus* found on AD as compared to normal skin. Once bound to AD skin, *S. aureus* must therefore rapidly proliferate as the result of impaired local immune responses. Interestingly, superantigens induce corticosteroid resistance of human T cells by up-regulation of the glucocorticoid-induced TNF receptor-related protein ligand (GITR-L) on monocytes<sup>95</sup> and signaling via the Raf-MEK-ERK1/ERK2 pathway of T cell receptor signaling.<sup>96</sup> These mechanisms might be of relevance in a subgroup of AD patients recalcitrant to treatment with corticosteroids.

## VIRAL INFECTIONS

AD in childhood as well as in adulthood can be complicated by localized or widespread cutaneous viral infections, which are specific for the disease. Virus infections observable in AD patients are most often caused by herpes simplex virus (HSV), human papilloma virus or molluscipox virus.<sup>97</sup> EH is a disseminated HSV 1 or 2 infection with severe systemic illness that occurs in 10% to 20% of patients with AD.<sup>98</sup> Risk factors for EH are an early onset of AD, severe and untreated AD, head and neck dermatitis, previous HSV infections and EH, and an elevated serum IgE combined with higher level of specific sensitizations, especially against *Malassezia sympodialis*.<sup>99,100</sup> Moreover, genetic variants in *IFNG* and *IFNGR1* as well as *IRF2* and *STAT6* were associated with EH and linked to lower IFN- $\gamma$  response in EH patients in vivo and in vitro.<sup>101–103</sup> Reduced gene expression in Claudin-1, a tight junction protein, has been identified as another putative risk factor for a higher propensity to viral infections induced by HSV of a subgroup of patients with AD.<sup>104</sup> Co-factors such as *S. aureus* and *S. aureus*-released alpha toxins might also be responsible for higher susceptibility of a subgroup of AD patients to EH since it has been demonstrated that alpha toxins promote viral

entry of HSV into human keratinocytes via ADAM10, a disintegrin and metalloprotease.<sup>105</sup> Furthermore, filaggrin and its breakdown products are reported to be capable of preventing HSV replication in vitro. Consequently, lower filaggrin expression due to loss-of function mutations in the *FLG* gene or secondary factors such as increased levels of IL-25, IL-4/IL-13 or other factors down-regulating filaggrin expression might increase the risk for disseminated HSV infections of the skin.<sup>106</sup>

## AUTOALLERGENS

In the 1920s several investigators reported that human skin dander could trigger immediate hypersensitivity reactions in the skin of patients with severe AD.<sup>107</sup> The potential molecular basis for these observations was demonstrated by Valenta et al, who reported that the majority of sera from patients with severe AD contain IgE antibodies directed against human proteins. One of these IgE-reactive autoantigens, a 55 kDa cytoplasmic protein in skin keratinocytes, has been cloned from a human epithelial cDNA expression library and designated Hom s 1. Such antibodies were not detected in patients with other skin diseases such as chronic urticaria, systemic lupus erythematosus or in healthy controls. Although the autoallergens characterized to date have mainly been intracellular proteins, they have been detected in IgE immune complexes of AD sera, suggesting that release of these autoallergens from damaged tissues could trigger responses mediated by IgE or T cells. This concept is supported by the recent observation that IgE autoallergen titers decreased with resolution of AD. These data suggest that, whereas IgE immune responses are initiated by environmental allergens, allergic inflammation can be maintained by human endogenous antigens, particularly in severe AD.

The reason for the development of IgE autoreactivity is currently unclear but it has been supposed that it might be based on chronic tissue damage due to repeated exposure to allergens in sensitized persons. Several atopy related autoantigens (ARA), including Hom s 1–5 and DSF 70, have been characterized so far. Strong IgE autoreactivity is detectable in particular in AD patients with high total serum IgE levels, a large number of sensitizations to food- and aeroallergens, early onset of AD and severe course.<sup>108</sup> Thus, IgE autoreactivity has been supposed to start in early infancy<sup>109</sup> and to contribute to very severe, therapy-resistant and chronic courses of disease. Specific IgE against the stress-inducible enzyme manganese superoxide dismutase (MnSOD), which cross-reacts to the skin-colonizing yeast *Malassezia sympodialis*, correlates with disease activity and has been found to induce T cell reactivity in vitro and eczematous reactions in APT in MnSOD-sensitized patients with AD.<sup>110</sup> Hom s 4 induced Th1 responses accompanied by the release of IFN- $\gamma$ , a cytokine involved in epithelial damage and chronic stages of skin inflammation.<sup>108,111</sup> These observations imply that autoreactivity might contribute to impairment of the allergic inflammatory reaction as well as to chronification of the disease.

## Conclusions

Atopic dermatitis is a common genetically transmitted inflammatory skin disease frequently found in association with respiratory allergy (Box 50-2). The diagnosis is mainly based on clinical parameters (Figure 50-5). The keys to management are: skin hydration; use of effective topical antiinflammatory agents such as corticosteroids, tacrolimus or pimecrolimus; and

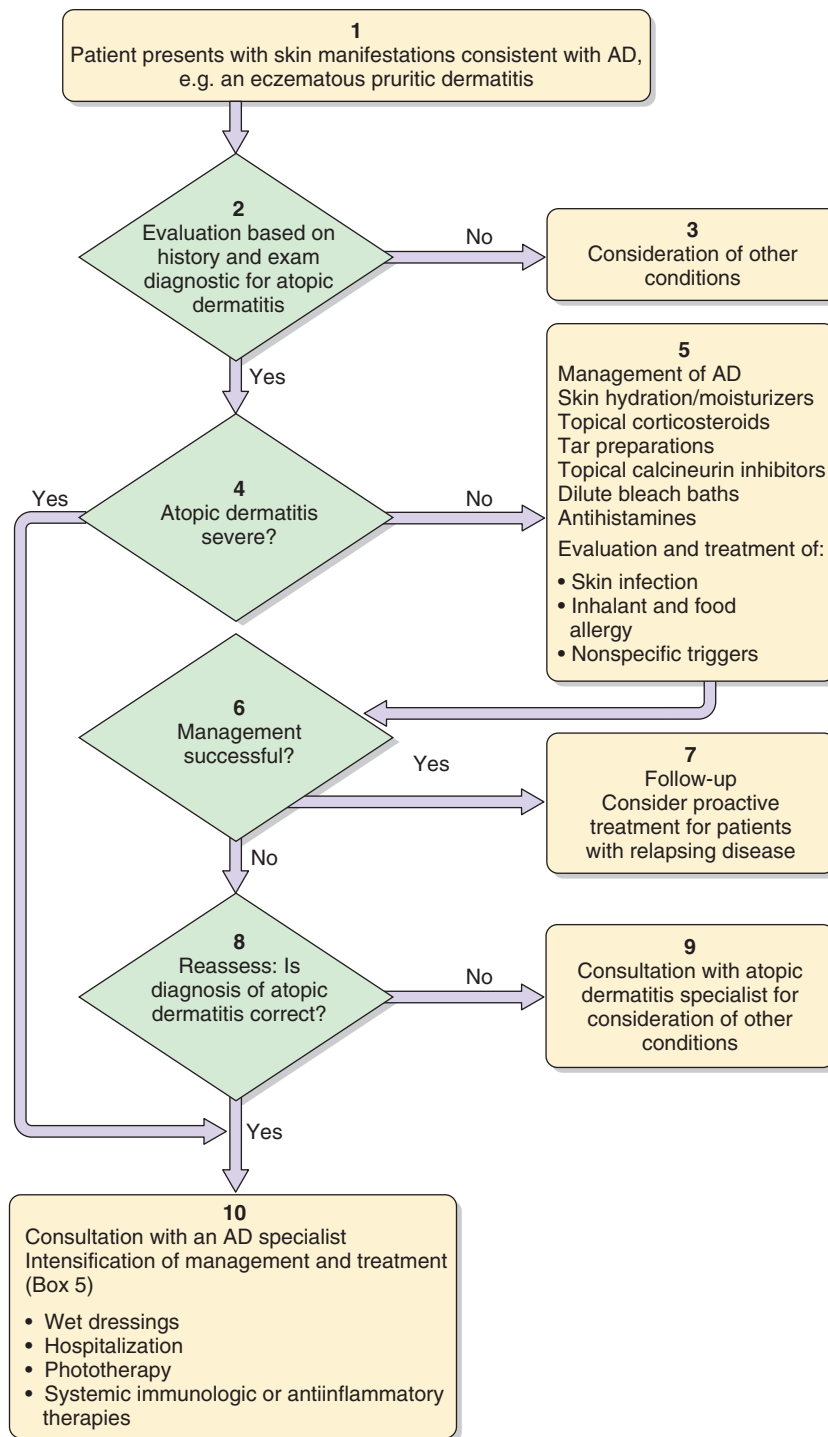

**Figure 50-5** Clinical algorithm for diagnosis and management of atopic dermatitis. (Reproduced with permission from Schneider L, Lio P, Boguniewicz M, Beck L, LeBovidge J, Novak N, et al. Atopic dermatitis: a practice parameter update 2012. *J Allergy Clin Immunol* 2013;131:295–9.)

**BOX 50-2 KEY CONCEPTS****ATOPIC DERMATITIS**

- Atopic dermatitis (AD) affects 10% to 20% of children.
- AD is a genetically transmitted chronic inflammatory allergic skin disease.
- Skin-homing T cells express T helper cell type 2 (Th2) cytokines that induce IgE and eosinophilia.
- Antigen-presenting cells in the skin (e.g. Langerhans cells) express surface-bound IgE molecules.
- Transition from acute to chronic AD is associated with a switch from predominantly Th2 cytokines to a combination of Th1 and Th2 cytokine gene expression.
- Immunologic triggers include foods, aeroallergens, microbial agents and autoallergens.

**BOX 50-3 THERAPEUTIC PRINCIPLES****ATOPIC DERMATITIS**

- Skin hydration and emollients are needed to repair skin barrier function.
- Topical antiinflammatory agents (corticosteroids, pimecrolimus, tacrolimus) are the cornerstones of therapy for acute flares and prevention of relapses.
- Avoidance of food and inhalant allergens may prevent flares.
- Antimicrobial therapy is often useful in poorly controlled patients.
- Sedating antihistamines may promote sleeping at night.
- Nonsedating antihistamines may be useful for patients with concomitant urticaria or coexisting respiratory allergy.
- Considerations for refractory patients include phototherapy, systemic glucocorticoids, cyclosporine, interferon- $\gamma$ , mycophenolate and methotrexate.

avoidance of allergenic triggers and skin irritants (Box 50-3). With a better understanding of the immunoregulatory abnormalities underlying AD, new paradigms are emerging to treat acute flares of AD more effectively and to prevent relapses of this skin condition.

**Helpful Websites**

The American Academy of Dermatology website ([www.aad.org/](http://www.aad.org/))

The American Academy of Family Physicians website ([www.aafp.org/afp/990915ap/1191.html](http://www.aafp.org/afp/990915ap/1191.html))

The National Eczema Association for Science and Education website ([www.nationaleczema.org/](http://www.nationaleczema.org/))

The American Academy of Allergy, Asthma & Immunology website ([www.aaaai.org/](http://www.aaaai.org/))

The complete reference list can be found on the companion Expert Consult website at <http://www.expertconsult.inkling.com>.

**KEY REFERENCES**

1. Boguniewicz M, Leung DY. Atopic dermatitis: a disease of altered skin barrier and immune dysregulation. *Immunol Rev* 2011;242:233–46.
15. Irvine AD, McLean WH, Leung DY. Filaggrin mutations associated with skin and allergic diseases. *N Engl J Med* 2011;365:1315–27.
23. Ellinghaus D, Baurecht H, Esparza-Gordillo J, Rodriguez E, Matanovic A, Marenholz I, et al. High-density genotyping study identifies four new susceptibility loci for atopic dermatitis. *Nat Genet* 2013;45:808–12.
24. Hirota T, Takahashi A, Kubo M, Tsunoda T, Tomita K, Sakashita M, et al. Genome-wide association study identifies eight new susceptibility loci for atopic dermatitis in the Japanese population. *Nat Genet* 2012;44:1222–6.
25. Rodriguez E, Baurecht H, Wahn AF, Kretschmer A, Hotze M, Zeilinger S, et al. An integrated epigenetic and transcriptomic analysis reveals distinct tissue-specific patterns of DNA methylation associated with atopic dermatitis. *J Invest Dermatol* 2014;134:1873–83.
42. Gittler JK, Shemer A, Suarez-Farinas M, Fuentes-Duculan J, Gulewicz KJ, Wang CQ, et al. Progressive activation of T(H)2/T(H)22 cytokines and selective epidermal proteins characterizes acute and chronic atopic dermatitis. *J Allergy Clin Immunol* 2012;130:1344–54.
61. Gros E, Petzold S, Maintz L, Bieber T, Novak N. Reduced IFN-gamma receptor expression and attenuated IFN-gamma response by dendritic cells in patients with atopic dermatitis. *J Allergy Clin Immunol* 2011;128:1015–21.
76. Guttman-Yassky E, Lowes MA, Fuentes-Duculan J, Zaba LC, Cardinale I, Nogales KE, et al. Low expression of the IL-23/Th17 pathway in atopic dermatitis compared to psoriasis. *J Immunol* 2008;181:7420–7.
101. Leung DY, Gao PS, Grigoryev DN, Rafaels NM, Streib JE, Howell MD, et al. Human atopic dermatitis complicated by eczema herpeticum is associated with abnormalities in IFN-gamma response. *J Allergy Clin Immunol* 2011;127:965–73 e1–5.
104. De Benedetto A, Slifka MK, Rafaels NM, Kuo IH, Georas SN, Boguniewicz M, et al. Reductions in claudin-1 may enhance susceptibility to herpes simplex virus 1 infections in atopic dermatitis. *J Allergy Clin Immunol* 2011;128:242–6.e5.



## REFERENCES

- Boguniewicz M, Leung DY. Atopic dermatitis: a disease of altered skin barrier and immune dysregulation. *Immunol Rev* 2011;242:233–46.
- Stensen L, Thomsen SF, Backer V. Change in prevalence of atopic dermatitis between 1986 and 2001 among children. *Allergy Asthma Proc* 2008;29:392–6.
- Akdis CA, Akdis M, Bieber T, Bindslev-Jensen C, Boguniewicz M, Eigenmann P, et al. Diagnosis and treatment of atopic dermatitis in children and adults: European Academy of Allergology and Clinical Immunology/American Academy of Allergy, Asthma and Immunology/PRACTALL Consensus Report. *J Allergy Clin Immunol* 2006;118:152–69.
- Elias PM, Hatano Y, Williams ML. Basis for the barrier abnormality in atopic dermatitis: outside-inside-outside pathogenic mechanisms. *J Allergy Clin Immunol* 2008;121:1337–43.
- Cookson W. The immunogenetics of asthma and eczema: a new focus on the epithelium. *Nat Rev Immunol* 2004;4:978–88.
- Hoffjan S, Epplen JT. The genetics of atopic dermatitis: recent findings and future options. *J Mol Med* 2005;83:682–92.
- Maintz L, Novak N. Getting more and more complex: the pathophysiology of atopic eczema. *Eur J Dermatol* 2007;17:267–83.
- Haagerup A, Bjerke T, Schiotz PO, Dahl R, Binderup HG, Tan Q, et al. Atopic dermatitis – a total genome-scan for susceptibility genes. *Acta Derm Venereol* 2004;84:346–52.
- Garmhausen D, Hagemann T, Bieber T, Dimitriou I, Fimmers R, Diepgen T, et al. Characterization of different courses of atopic dermatitis in adolescent and adult patients. *Allergy* 2013;68:498–506.
- Novak N. New insights into the mechanism and management of allergic diseases: atopic dermatitis. *Allergy* 2009;64:265–75.
- Novak N, Simon D. Atopic dermatitis – from new pathophysiologic insights to individualized therapy. *Allergy* 2011;66:830–9.
- Gupta J, Grube E, Erickson MB, Stevenson MD, Lucky AW, Sheth AP, et al. Intrinsically defective skin barrier function in children with atopic dermatitis correlates with disease severity. *J Allergy Clin Immunol* 2008;121:725–30.
- Kezic S, Kemperman PM, Koster ES, de Jongh CM, Thio HB, Campbell LE, et al. Loss-of-function mutations in the filaggrin gene lead to reduced level of natural moisturizing factor in the stratum corneum. *J Invest Dermatol* 2008;128:2117–19.
- McGrath JA, Uitto J. The filaggrin story: novel insights into skin-barrier function and disease. *Trends Mol Med* 2008;14:20–7.
- Irvine AD, McLean WH, Leung DY. Filaggrin mutations associated with skin and allergic diseases. *N Engl J Med* 2011;365:1315–27.
- Palmer CN, Irvine AD, Terron-Kwiatkowski A, Zhao Y, Liao H, Lee SP, et al. Common loss-of-function variants of the epidermal barrier protein filaggrin are a major predisposing factor for atopic dermatitis. *Nat Genet* 2006;38:441–6.
- Baurecht H, Irvine AD, Novak N, Illig T, Buhler B, Ring J, et al. Toward a major risk factor for atopic eczema: meta-analysis of filaggrin polymorphism data. *J Allergy Clin Immunol* 2007;120:1406–12.
- Bisgaard H, Simpson A, Palmer CN, Bonnelykke K, McLean I, Mukhopadhyay S, et al. Gene-environment interaction in the onset of eczema in infancy: filaggrin loss-of-function mutations enhanced by neonatal cat exposure. *PLoS Med* 2008;5:e131.
- Vasilopoulos Y, Cork MJ, Murphy R, Williams HC, Robinson DA, Duff GW, et al. Genetic association between an AACC insertion in the 3′UTR of the stratum corneum chymotryptic enzyme gene and atopic dermatitis. *J Invest Dermatol* 2004;123:62–6.
- Soderhall C, Marenholz I, Kerscher T, Ruschen-dorf F, Esparza-Gordillo J, Worm M, et al. Variants in a novel epidermal collagen gene (COL29A1) are associated with atopic dermatitis. *PLoS Biol* 2007;5:e242.
- Cork MJ, Robinson DA, Vasilopoulos Y, Ferguson A, Moustafa M, MacGowan A, et al. New perspectives on epidermal barrier dysfunction in atopic dermatitis: gene-environment interactions. *J Allergy Clin Immunol* 2006;118:3–21.
- Jeong SK, Kim HJ, Youm JK, Ahn SK, Choi EH, Sohn MH, et al. Mite and cockroach allergens activate protease-activated receptor 2 and delay epidermal permeability barrier recovery. *J Invest Dermatol* 2008;128:1930–9.
- Ellinghaus D, Baurecht H, Esparza-Gordillo J, Rodriguez E, Matanovic A, Marenholz I, et al. High-density genotyping study identifies four new susceptibility loci for atopic dermatitis. *Nat Genet* 2013;45:808–12.
- Hirota T, Takahashi A, Kubo M, Tsunoda T, Tomita K, Sakashita M, et al. Genome-wide association study identifies eight new susceptibility loci for atopic dermatitis in the Japanese population. *Nat Genet* 2012;44:1222–6.
- Rodriguez E, Baurecht H, Wahn AF, Kretschmer A, Hotze M, Zeilinger S, et al. An integrated epigenetic and transcriptomic analysis reveals distinct tissue-specific patterns of DNA methylation associated with atopic dermatitis. *J Invest Dermatol* 2014;134:1873–83.
- Cook DN, Pisetsky DS, Schwartz DA. Toll-like receptors in the pathogenesis of human disease. *Nat Immunol* 2004;5:975–9.
- Murray PJ. NOD proteins: an intracellular pathogen-recognition system or signal transduction modifiers? *Curr Opin Immunol* 2005;17:352–8.
- Ahmad-Nejad P, Mrabet-Dahbi S, Breuer K, Klotz M, Werfel T, Herz U, et al. The toll-like receptor 2 R753Q polymorphism defines a subgroup of patients with atopic dermatitis having severe phenotype. *J Allergy Clin Immunol* 2004;113:565–7.
- Mrabet-Dahbi S, Dalpke AH, Niebuhr M, Frey M, Draing C, Brand S, et al. The Toll-like receptor 2 R753Q mutation modifies cytokine production and Toll-like receptor expression in atopic dermatitis. *J Allergy Clin Immunol* 2008;121:1013–19.
- Hoffjan S, Stemmler S, Parwez Q, Petrasch-Parwez E, Arinir U, Rohde G, et al. Evaluation of the toll-like receptor 6 Ser249Pro polymorphism in patients with asthma, atopic dermatitis and chronic obstructive pulmonary disease. *BMC Med Genet* 2005;6:34.
- Weidinger S, Novak N, Klopp N, Baurecht H, Wagenpfeil S, Rummeler L, et al. Lack of association between Toll-like receptor 2 and Toll-like receptor 4 polymorphisms and atopic eczema. *J Allergy Clin Immunol* 2006;118:277–9.
- Novak N, Yu CF, Bussmann C, Maintz L, Peng WM, Hart J, et al. Putative association of a TLR9 promoter polymorphism with atopic eczema. *Allergy* 2007;62:766–72.
- Novak N, Bieber T, Leung DY. Immune mechanisms leading to atopic dermatitis. *J Allergy Clin Immunol* 2003;112(6 Suppl.):S128–39.
- Steinke JW, Borish L, Rosenwasser LJ. 5. Genetics of hypersensitivity. *J Allergy Clin Immunol* 2003;111(2 Suppl.):S495–501.
- Wollenberg A, Klein E. Current aspects of innate and adaptive immunity in atopic dermatitis. *Clin Rev Allergy Immunol* 2007;33:35–44.
- Weidinger S, Klopp N, Wagenpfeil S, Rummeler L, Schedel M, Kabesch M, et al. Association of a STAT 6 haplotype with elevated serum IgE levels in a population based cohort of white adults. *J Med Genet* 2004;41:658–63.
- Novak N, Kruse S, Potreck J, Maintz L, Jenneck C, Weidinger S, et al. Single nucleotide polymorphisms of the IL18 gene are associated with atopic eczema. *J Allergy Clin Immunol* 2005;115:828–33.
- Machura E, Mazur B, Golemiec E, Pindel M, Halkiewicz F. Staphylococcus aureus skin colonization in atopic dermatitis children is associated with decreased IFN-gamma production by peripheral blood CD4+ and CD8+ T cells. *Pediatr Allergy Immunol* 2008;19:37–45.
- Proksch E, Folster-Holst R, Jensen JM. Skin barrier function, epidermal proliferation and differentiation in eczema. *J Dermatol Sci* 2006;43:159–69.
- Eyerich K, Huss-Marp J, Darsow U, Wollenberg A, Foerster S, Ring J, et al. Pollen grains induce a rapid and biphasic eczematous immune response in atopic eczema patients. *Int Arch Allergy Immunol* 2008;145:213–23.
- Kerschenlohr K, Decard S, Przybilla B, Wollenberg A. Atopy patch test reactions show a rapid influx of inflammatory dendritic epidermal cells in patients with extrinsic atopic dermatitis and patients with intrinsic atopic dermatitis. *J Allergy Clin Immunol* 2003;111:869–74.
- Gittler JK, Shemer A, Suarez-Farinas M, Fuentes-Duculan J, Gulewicz KJ, Wang CQ, et al. Progressive activation of T(H)2/T(H)22 cytokines and selective epidermal proteins characterizes acute and chronic atopic dermatitis. *J Allergy Clin Immunol* 2012;130:1344–54.
- Simon D, Vassina E, Yousefi S, Kozlowski E, Braathen LR, Simon HU. Reduced dermal infiltration of cytokine-expressing inflammatory cells in atopic dermatitis after short-term topical tacrolimus treatment. *J Allergy Clin Immunol* 2004;114:887–95.
- Simon D, Vassina E, Yousefi S, Braathen LR, Simon HU. Inflammatory cell numbers and cytokine expression in atopic dermatitis after topical pimecrolimus treatment. *Allergy* 2005;60:944–51.
- Teraki Y, Sakurai A, Izaki S. IL-13/IL-22-coproducing T cells, a novel subset, are increased in atopic dermatitis. *J Allergy Clin Immunol* 2013;132:971–4.
- Zhang Z, Xiao C, Gibson AM, Bass SA, Khurana Hershey GK. EGFR signaling blunts allergen-induced IL-6 production and Th17 responses in the skin and attenuates develop-

- ment and relapse of atopic dermatitis. *J Immunol* 2014;192:859–66.
47. Nakajima S, Kitoh A, Egawa G, Natsuki Y, Nakamizo S, Moniaga CS, et al. IL-17A as an inducer for Th2 immune responses in murine atopic dermatitis models. *J Invest Dermatol* 2014;134:2122–30.
  48. Simon D, Lindberg RL, Kozlowski E, Braathen LR, Simon HU. Epidermal caspase-3 cleavage associated with interferon-gamma-expressing lymphocytes in acute atopic dermatitis lesions. *Exp Dermatol* 2006;15:441–6.
  49. Rebane A, Zimmermann M, Aab A, Baurecht H, Koreck A, Karelson M, et al. Mechanisms of IFN-gamma-induced apoptosis of human skin keratinocytes in patients with atopic dermatitis. *J Allergy Clin Immunol* 2012;129:1297–306.
  50. Brauweiler AM, Goleva E, Leung DY. Th2 cytokines increase *Staphylococcus aureus* alpha toxin-induced keratinocyte death through the Signal Transducer and Activator of Transcription 6 (STAT6). *J Invest Dermatol* 2014;134:2114–21.
  51. Brauweiler AM, Bin L, Kim BE, Oyoshi MK, Geha RS, Goleva E, et al. Filaggrin-dependent secretion of sphingomyelinase protects against staphylococcal alpha-toxin-induced keratinocyte death. *J Allergy Clin Immunol* 2013;131:421–7 e1–2.
  52. Verhagen J, Akdis M, Traidl-Hoffmann C, Schmid-Grendelmeier P, Hijnen D, Knol EF, et al. Absence of T-regulatory cell expression and function in atopic dermatitis skin. *J Allergy Clin Immunol* 2006;117:176–83.
  53. Reefer AJ, Satinover SM, Solga MD, Lannigan JA, Nguyen JT, Wilson BB, et al. Analysis of CD25hiCD4+ 'regulatory' T-cell subtypes in atopic dermatitis reveals a novel T(H)2-like population. *J Allergy Clin Immunol* 2008;121:415–22.
  54. Novak N, Peng W, Yu C. Network of myeloid and plasmacytoid dendritic cells in atopic dermatitis. *Adv Exp Med Biol* 2007;601:97–104.
  55. Novak N, Tepel C, Koch S, Brix K, Bieber T, Kraft S. Evidence for a differential expression of the FcepsilonRIgamma chain in dendritic cells of atopic and nonatopic donors. *J Clin Invest* 2003;111:1047–56.
  56. Stary G, Bangert C, Stingl G, Kopp T. Dendritic cells in atopic dermatitis: expression of FcepsilonRI on two distinct inflammation-associated subsets. *Int Arch Allergy Immunol* 2005;138:278–90.
  57. Fujita H, Shemer A, Suárez-Fariñas M, Johnson-Huang LM, Tintle S, Cardinale I, et al. Lesional dendritic cells in patients with chronic atopic dermatitis and psoriasis exhibit parallel ability to activate T-cell subsets. *J Allergy Clin Immunol* 2011;128:574–82.
  58. Novak N, Peng WM, Bieber T, Akdis C. FcepsilonRI stimulation promotes the differentiation of histamine receptor 1-expressing inflammatory macrophages. *Allergy* 2013;68:454–61.
  59. Novak N, Valenta R, Bohle B, Laffer S, Haberstock J, Kraft S, et al. FcepsilonRI engagement of Langerhans cell-like dendritic cells and inflammatory dendritic epidermal cell-like dendritic cells induces chemotactic signals and different T-cell phenotypes in vitro. *J Allergy Clin Immunol* 2004;113:949–57.
  60. Peng WM, Maintz L, Allam JP, Novak N. Attenuated TGF-beta1 responsiveness of dendritic cells and their precursors in atopic dermatitis. *Eur J Immunol* 2013;43:1374–82.
  61. Gros E, Petzold S, Maintz L, Bieber T, Novak N. Reduced IFN-gamma receptor expression and attenuated IFN-gamma response by dendritic cells in patients with atopic dermatitis. *J Allergy Clin Immunol* 2011;128:1015–21.
  62. Sakurai D, Yamasaki S, Arase K, Park SY, Arase H, Konno A, et al. Fc epsilon RI gamma-ITAM is differentially required for mast cell function in vivo. *J Immunol* 2004;172:2374–81.
  63. Novak N, Allam JP, Hagemann T, Jenneck C, Laffer S, Valenta R, et al. Characterization of FcepsilonRI-bearing CD123 blood dendritic cell antigen-2 plasmacytoid dendritic cells in atopic dermatitis. *J Allergy Clin Immunol* 2004;114:364–70.
  64. Nockher WA, Renz H. Neurotrophins in allergic diseases: from neuronal growth factors to intercellular signaling molecules. *J Allergy Clin Immunol* 2006;117:583–9.
  65. Tversky JR, Le TV, Bieneman AP, Chichester KL, Hamilton RG, Schroeder JT. Human blood dendritic cells from allergic subjects have impaired capacity to produce interferon-alpha via Toll-like receptor 9. *Clin Exp Allergy* 2008;38:781–8.
  66. Schroeder JT, Bieneman AP, Xiao H, Chichester KL, Vasagar K, Saini S, et al. TLR9- and FcepsilonRI-mediated responses oppose one another in plasmacytoid dendritic cells by down-regulating receptor expression. *J Immunol* 2005;175:5724–31.
  67. Homey B, Steinhoff M, Ruzicka T, Leung DY. Cytokines and chemokines orchestrate atopic skin inflammation. *J Allergy Clin Immunol* 2006;118:178–89.
  68. Park CW, Lee BH, Han HJ, Lee CH, Ahn HK. Tacrolimus decreases the expression of eotaxin, CCR3, RANTES and interleukin-5 in atopic dermatitis. *Br J Dermatol* 2005;152:1173–81.
  69. Gunther C, Bello-Fernandez C, Kopp T, Kund J, Carballido-Perrig N, Hinteregger S, et al. CCL18 is expressed in atopic dermatitis and mediates skin homing of human memory T cells. *J Immunol* 2005;174:1723–8.
  70. Pivarcsi A, Gombert M, Dieu-Nosjean MC, Lauerma A, Kubitz R, Meller S, et al. CC chemokine ligand 18, an atopic dermatitis-associated and dendritic cell-derived chemokine, is regulated by staphylococcal products and allergen exposure. *J Immunol* 2004;173:5810–17.
  71. Gombert M, Dieu-Nosjean MC, Winterberg F, Bunemann E, Kubitz RC, Da CL, et al. CCL1-CCR8 interactions: an axis mediating the recruitment of T cells and Langerhans-type dendritic cells to sites of atopic skin inflammation. *J Immunol* 2005;174:5082–91.
  72. Sonkoly E, Muller A, Lauerma AI, Pivarcsi A, Soto H, Kemeny L, et al. IL-31: a new link between T cells and pruritus in atopic skin inflammation. *J Allergy Clin Immunol* 2006;117:411–17.
  73. Bilsborough J, Leung DY, Maurer M, Howell M, Boguniewicz M, Yao L, et al. IL-31 is associated with cutaneous lymphocyte antigen-positive skin homing T cells in patients with atopic dermatitis. *J Allergy Clin Immunol* 2006;117:418–25.
  74. Neis MM, Peters B, Dreuw A, Wenzel J, Bieber T, Mauch C, et al. Enhanced expression levels of IL-31 correlate with IL-4 and IL-13 in atopic and allergic contact dermatitis. *J Allergy Clin Immunol* 2006;118:930–7.
  75. Dillon SR, Sprecher C, Hammond A, Bilsborough J, Rosenfeld-Franklin M, Presnell SR, et al. Interleukin 31, a cytokine produced by activated T cells, induces dermatitis in mice. *Nat Immunol* 2004;5:752–60.
  76. Guttman-Yassky E, Lowes MA, Fuentes-Duculan J, Zaba LC, Cardinale I, Nograles KE, et al. Low expression of the IL-23/Th17 pathway in atopic dermatitis compared to psoriasis. *J Immunol* 2008;181:7420–7.
  77. Yoo J, Omori M, Gyarmati D, Zhou B, Aye T, Brewer A, et al. Spontaneous atopic dermatitis in mice expressing an inducible thymic stromal lymphopoietin transgene specifically in the skin. *J Exp Med* 2005;202:541–9.
  78. Esnault S, Rosenthal LA, Wang DS, Malter JS. Thymic stromal lymphopoietin (TSLP) as a bridge between infection and atopy. *Int J Clin Exp Pathol* 2008;1:325–30.
  79. Ebner S, Nguyen VA, Forstner M, Wang YH, Wolfram D, Liu YJ, et al. Thymic stromal lymphopoietin converts human epidermal Langerhans cells into antigen-presenting cells that induce proallergic T cells. *J Allergy Clin Immunol* 2007;119:982–90.
  80. Howell MD. The role of human beta defensins and cathelicidins in atopic dermatitis. *Curr Opin Allergy Clin Immunol* 2007;7:413–17.
  81. Howell MD, Gallo RL, Boguniewicz M, Jones JF, Wong C, Streib JE, et al. Cytokine milieu of atopic dermatitis skin subverts the innate immune response to vaccinia virus. *Immunity* 2006;24:341–8.
  82. Nomura I, Goleva E, Howell MD, Hamid QA, Ong PY, Hall CF, et al. Cytokine milieu of atopic dermatitis, as compared to psoriasis, skin prevents induction of innate immune response genes. *J Immunol* 2003;171:3262–9.
  83. Howell MD, Novak N, Bieber T, Pastore S, Girolomoni G, Boguniewicz M, et al. Interleukin-10 downregulates anti-microbial peptide expression in atopic dermatitis. *J Invest Dermatol* 2005;125:738–45.
  84. Kisich KO, Carspecken CW, Fieve S, Boguniewicz M, Leung DY. Defective killing of *Staphylococcus aureus* in atopic dermatitis is associated with reduced mobilization of human beta-defensin-3. *J Allergy Clin Immunol* 2008;122:62–8.
  85. Howell MD, Jones JF, Kisich KO, Streib JE, Gallo RL, Leung DY. Selective killing of vaccinia virus by LL-37: implications for eczema vaccinatum. *J Immunol* 2004;172:1763–7.
  86. Howell MD, Wollenberg A, Gallo RL, Flaig M, Streib JE, Wong C, et al. Cathelicidin deficiency predisposes to eczema herpeticum. *J Allergy Clin Immunol* 2006;117:836–41.
  87. Rieg S, Steffen H, Seeber S, Humeny A, Kalbacher H, Dietz K, et al. Deficiency of dermcidin-derived antimicrobial peptides in sweat of patients with atopic dermatitis correlates with an impaired innate defense of human skin in vivo. *J Immunol* 2005;174:8003–10.
  88. Hata TR, Kotel P, Jackson M, Nguyen M, Paik A, Udall D, et al. Administration of oral vitamin D induces cathelicidin production in atopic individuals. *J Allergy Clin Immunol* 2008;122:829–31.
  89. Liu PT, Stenger S, Li H, Wenzel L, Tan BH, Krutzik SR, et al. Toll-like receptor triggering of a vitamin D-mediated human antimicrobial response. *Science* 2006;311:1770–3.
  90. Schaubert J, Dorschner RA, Coda AB, Buchau AS, Liu PT, Kiken D, et al. Injury enhances TLR2 function and antimicrobial peptide expression through a vitamin D-dependent mechanism. *J Clin Invest* 2007;117:803–11.

91. Wang TT, Nestel FP, Bourdeau V, Nagai Y, Wang Q, Liao J, et al. Cutting edge: 1,25-dihydroxyvitamin D3 is a direct inducer of antimicrobial peptide gene expression. *J Immunol* 2004;173:2909–12.
92. Hauk PJ. The role of food allergy in atopic dermatitis. *Curr Allergy Asthma Rep* 2008;8:188–94.
93. Ramesh S. Food allergy overview in children. *Clin Rev Allergy Immunol* 2008;34:217–30.
94. Bonness S, Szekat C, Novak N, Bierbaum G. Pulsed-field gel electrophoresis of *Staphylococcus aureus* isolates from atopic patients revealing presence of similar strains in isolates from children and their parents. *J Clin Microbiol* 2008;46:456–61.
95. Cardona ID, Goleva E, Ou LS, Leung DY. Staphylococcal enterotoxin B inhibits regulatory T cells by inducing glucocorticoid-induced TNF receptor-related protein ligand on monocytes. *J Allergy Clin Immunol* 2006;117:688–95.
96. Li LB, Goleva E, Hall CF, Ou LS, Leung DY. Superantigen-induced corticosteroid resistance of human T cells occurs through activation of the mitogen-activated protein kinase/kinase/extracellular signal-regulated kinase (MEK-ERK) pathway. *J Allergy Clin Immunol* 2004;114:1059–69.
97. Wollenberg A, Wetzel S, Burgdorf WH, Haas J. Viral infections in atopic dermatitis: pathogenic aspects and clinical management. *J Allergy Clin Immunol* 2003;112:667–74.
98. Bussmann C, Peng WM, Bieber T, Novak N. Molecular pathogenesis and clinical implications of eczema herpeticum. *Expert Rev Mol Med* 2008;10:e21.
99. Peng WM, Jenneck C, Bussmann C, Bogdanow M, Hart J, Leung DY, et al. Risk factors of atopic dermatitis patients for eczema herpeticum. *J Invest Dermatol* 2007;127:1261–3.
100. Wollenberg A, Zoch C, Wetzel S, Plewig G, Przybilla B. Predisposing factors and clinical features of eczema herpeticum: a retrospective analysis of 100 cases. *J Am Acad Dermatol* 2003;49:198–205.
101. Leung DY, Gao PS, Grigoryev DN, Rafaels NM, Streib JE, Howell MD, et al. Human atopic dermatitis complicated by eczema herpeticum is associated with abnormalities in IFN-gamma response. *J Allergy Clin Immunol* 2011;127:965–73 e1–5.
102. Gao PS, Leung DY, Rafaels NM, Boguniewicz M, Hand T, Gao L, et al. Genetic variants in interferon regulatory factor 2 (IRF2) are associated with atopic dermatitis and eczema herpeticum. *J Invest Dermatol* 2012;132(3 Pt 1):650–7.
103. Howell MD, Gao P, Kim BE, Lesley LJ, Streib JE, Taylor PA, et al. The signal transducer and activator of transcription 6 gene (STAT6) increases the propensity of patients with atopic dermatitis toward disseminated viral skin infections. *J Allergy Clin Immunol* 2011;128:1006–14.
104. De Benedetto A, Slifka MK, Rafaels NM, Kuo IH, Georas SN, Boguniewicz M, et al. Reductions in claudin-1 may enhance susceptibility to herpes simplex virus 1 infections in atopic dermatitis. *J Allergy Clin Immunol* 2011;128:242–6 e5.
105. Bin L, Kim BE, Brauweiler A, Goleva E, Streib J, Ji Y, et al. *Staphylococcus aureus* alpha-toxin modulates skin host response to viral infection. *J Allergy Clin Immunol* 2012;130:683–91 e2.
106. Kim BE, Bin L, Ye YM, Ramamoorthy P, Leung DY. IL-25 enhances HSV-1 replication by inhibiting filaggrin expression, and acts synergistically with Th2 cytokines to enhance HSV-1 replication. *J Invest Dermatol* 2013;133:2678–85.
107. Valenta R, Mittermann I, Werfel T, Garn H, Renz H. Linking allergy to autoimmune disease. *Trends Immunol* 2009;30:109–16.
108. Mittermann I, Reiningger R, Zimmermann M, Gangl K, Reisinger J, Aichberger KJ, et al. The IgE-reactive autoantigen Hom s 2 induces damage of respiratory epithelial cells and keratinocytes via induction of IFN-gamma. *J Invest Dermatol* 2007;128:1451–9.
109. Mothes N, Niggemann B, Jenneck C, Hagemann T, Weidinger S, Bieber T, et al. The cradle of IgE autoreactivity in atopic eczema lies in early infancy. *J Allergy Clin Immunol* 2005;116:706–9.
110. Schmid-Grendelmeier P, Fluckiger S, Disch R, Trautmann A, Wuthrich B, Blaser K, et al. IgE-mediated and T cell-mediated autoimmunity against manganese superoxide dismutase in atopic dermatitis. *J Allergy Clin Immunol* 2005;115:1068–75.
111. Aichberger KJ, Mittermann I, Reiningger R, Seiberler S, Swoboda I, Spitzauer S, et al. Hom s 4, an IgE-reactive autoantigen belonging to a new subfamily of calcium-binding proteins, can induce Th cell type 1-mediated autoreactivity. *J Immunol* 2005;175:1286–94.

# Management of Atopic Dermatitis

MARK BOGUNIEWICZ | DONALD Y.M. LEUNG

## KEY POINTS

- Proper skin hydration and skin barrier protection are key to management of atopic dermatitis (AD).
- Topical antiinflammatory therapy includes use of topical steroids and calcineurin inhibitors.
- Identification and elimination of relevant triggers is an essential component of managing AD.
- Patient and caregiver education is a critical part of caring for patients with AD.
- The risks vs benefits of systemic therapy need to be considered for patients failing conventional therapy.

Atopic dermatitis (AD) is a common, frequently relapsing inflammatory disease that affects up to 20% of children (see the ‘Epidemiology’ section of Chapter 50) and has a significant impact on the quality of life of patients and families. Management approaches in AD have evolved with our increasing understanding of the mechanisms underlying this skin disease. While AD is the most common chronic skin disease of children, it is important to bear in mind the differential diagnosis of a pruritic rash when starting therapy, especially if there are atypical features or the response to treatment is suboptimal. Note that, while rare, cutaneous T cell lymphoma/mycosis fungoides can occur in adolescents and even children (see [Box 51-1](#)). Given the complex nature of AD and its chronic, relapsing course, it will often require a multipronged approach directed at healing or protecting the skin barrier and addressing the immune dysregulation to improve the likelihood of successful outcomes. This includes proper skin hydration and identification and elimination of flare factors such as irritants, allergens, infectious agents and emotional stressors, as well as pharmacologic therapy ([Figure 51-1](#)).<sup>1</sup>

## Hydration and Skin Barrier Protective Measures

As discussed in Chapter 50, patients with AD have genetic or immune-mediated abnormalities in skin barrier function.<sup>2</sup> Of note, filaggrin contributes not only to barrier integrity, but also to hydration through generation of hygroscopic amino acids that are a key component of natural moisturizing factor (NMF). NMF is also involved in the maintenance of skin pH and regulation of key biochemical events, including protease activity, barrier permeability and cutaneous antimicrobial defense. Filaggrin may also contribute to the acid mantle through acid degradation products. Children with AD have dry skin (xerosis)

with microfissures and epidermal defects that serve as portals of entry for irritants, allergens and skin pathogens. Transepidermal water loss occurs even through normal appearing skin.

Hydration of the skin can be accomplished through warm (note that lukewarm and tepid are not comfortable temperatures for bathing!) soaking baths for approximately 10 minutes, followed by immediate application of a moisturizer or medication to prevent evaporation and promote healing. Bathing also removes irritants, allergens and skin pathogens and provides symptomatic relief. Bathing should also be an enjoyable activity. This can be accomplished by providing appropriate bath toys for younger children that are reserved for tub time, or a caregiver may choose to read to them. Older children can read or play hand-held games that are safe for a tub. It is important that areas involved by eczema are immersed, not just wet. Wet towels can be used to hydrate the head and neck regions, with masks created to make the experience both therapeutic and enjoyable. Young children need to be supervised. Baths can be taken several times per day during eczema flares, while showers may be substituted in milder disease or to accommodate busy schedules, especially in the mornings. Cleansers with minimal defatting activity and a neutral pH can be used as necessary. Preparations formulated for sensitive skin that are dye and fragrance free are generally well tolerated. Antibacterial cleansers may be helpful for patients with folliculitis or recurrent skin infections. Patients should be instructed not to scrub with a washcloth while using cleansers. Addition of bleach (sodium hypochlorite) to bath water, especially for patients with methicillin-resistant *Staphylococcus aureus* (MRSA), has been advocated. However, the amount of bleach per volume of water (e.g. an eighth to a half cup per tub of water) and the frequency of such treatments (e.g. 1 to 3 times weekly) have not been well studied and bleach baths can cause significant skin irritation. In a single-center controlled study, children with AD were treated with dilute sodium hypochlorite baths (a half cup of 6% bleach added to 40 gallons of water) twice weekly for 5 to 10 minutes, combined with nasal mupirocin twice daily for 5 days each month, over a 3-month period.<sup>3</sup> Patients tolerated the dilute bleach baths although the number of patients colonized with MRSA was low and, despite clinical improvement, patients remained colonized by *S. aureus* even after 3 months of intervention.

Use of an effective moisturizer combined with hydration therapy will help to restore and preserve the stratum corneum barrier.<sup>4</sup> Moisturizers can also improve skin barrier function, reduce susceptibility to irritants, improve clinical parameters of AD and decrease the need for topical corticosteroids.<sup>5-7</sup> Ingredients that contribute to effective moisturizers include humectants to attract and hold water in the skin such as glycerol, occlusives such as petrolatum to retard evaporation, and emollients such as lanolin to lubricate the stratum corneum.<sup>8</sup>



**BOX 51-1 DIFFERENTIAL DIAGNOSIS OF ATOPIC DERMATITIS****CONGENITAL DISORDERS**

Netherton's syndrome  
Familial keratosis pilaris

**CHRONIC DERMATOSES**

Seborrheic dermatitis  
Contact dermatitis (allergic or irritant)  
Nummular eczema  
Psoriasis  
Ichthyoses

**INFECTIONS AND INFESTATIONS**

Scabies  
Human immunodeficiency virus-associated dermatitis  
Dermatophytosis

**MALIGNANCIES**

Cutaneous T cell lymphoma (mycosis fungoides/Sézary syndrome)  
Letterer-Siwe disease

**AUTOIMMUNE DISORDERS**

Dermatitis herpetiformis  
Pemphigus foliaceus  
Graft-versus-host disease  
Dermatomyositis

**IMMUNODEFICIENCIES**

Wiskott-Aldrich syndrome  
Severe combined immunodeficiency syndrome  
Hyper-IgE syndrome  
Dedicator of cytokinesis 8 (DOCK8) associated immunodeficiency  
Immune dysregulation, polyendocrinopathy, enteropathy X-linked (IPEX) syndrome

**METABOLIC DISORDERS**

Zinc deficiency  
Pyridoxine (vitamin B<sub>6</sub>) and niacin  
Multiple carboxylase deficiency  
Phenylketonuria

Moisturizers are available as ointments, creams, lotions and oils. While ointments have the fewest additives and are the most occlusive, in a hot, humid environment they may trap sweat with associated irritation of the skin. Lotions and creams may be irritating due to added preservatives, solubilizers and fragrances. Lotions contain more water than creams and may be drying due to an evaporative effect. Oils are also less effective moisturizers. Moisturizers should be obtained in the largest size available (one pound jars) since they may need to be applied several times each day on a chronic basis. Vegetable shortening (Crisco®) can be used as an inexpensive moisturizer. Of note, patients and caregivers should understand that petroleum jelly (Vaseline®) is an occlusive, not a moisturizer, and thus needs to be applied on damp, not dry skin. Even young children can be taught to apply their moisturizer, allowing them to participate in their skin care. Patients and caregivers need to be instructed to apply moisturizers routinely but not over or immediately prior to topical medications to avoid dilution or interference with medication on skin.

A number of studies suggest that AD is associated with decreased levels of ceramides, contributing not only to a damaged permeability barrier but also making the stratum

corneum susceptible to colonization by *S. aureus*.<sup>9</sup> A ceramide-dominant emollient added to standard therapy in place of moisturizer in children with 'stubborn-to-recalcitrant' AD was shown to result in clinical improvement.<sup>10</sup> Several ceramide-containing creams are available, including Epiceram® which is registered as a medical device and thus available only by prescription. Preliminary data suggest clinical benefit comparable to a topical mid-potency corticosteroid.<sup>11</sup> Other nonsteroidal creams registered as medical devices with unique ingredients include MAS063DP (Atopiclair®)<sup>12</sup> and S236 (Mimyx®).<sup>13</sup> These creams are not regulated by the US Food and Drug Administration (FDA) and have no restrictions on age or length of use. They may be especially attractive to parents who have concerns about using topical corticosteroids and calcineurin inhibitors. However, they are costly and their place in the treatment algorithm for AD has not been definitively established.

**Topical Antiinflammatory Therapy****TOPICAL GLUCOCORTICOIDS**

Glucocorticoids have been the cornerstone of antiinflammatory treatment for over 50 years. Because of potential side-effects, topical glucocorticoids are used primarily to control acute exacerbations of AD.<sup>1</sup>

Patients should be carefully instructed in the use of topical glucocorticoids to avoid potential side-effects. The potent fluorinated glucocorticoids should be avoided on the face, the genitalia and the intertriginous areas. Patients should be instructed to apply topical glucocorticoids to their skin lesions and to use emollients over uninvolved skin. Failure of a patient to respond to topical glucocorticoids is often due to the inadequate amount applied. It is important to remember that it takes approximately 30 g of cream or ointment to cover the entire skin surface of an adult-sized patient for one application. The fingertip unit (FTU) has been proposed as a measure for applying topical corticosteroids and has been studied in children with AD.<sup>14,15</sup> This is the amount of topical medication that extends from the tip to the first joint on the palmar aspect of the index finger. It takes approximately one FTU to cover the hand or groin, 2 FTUs for the face or foot, 3 FTUs for an arm, 6 FTUs for a leg, and 14 FTUs for the trunk. Of note, adequate application of topical corticosteroids has been shown to correlate with clinical improvement.<sup>16</sup> Obtaining medications in larger quantities can result in significant savings for patients.

There are seven classes of topical glucocorticoids, ranked according to their potency based on vasoconstrictor assays from super-potent (class I) to low potent (class VII). Because of their potential side-effects, the super-potent and high-potent glucocorticoids should be used only for short periods of time and in areas that are lichenified, but not on the face or intertriginous areas. The goal is to use moisturizers to enhance skin hydration and lower-potency glucocorticoids or nonsteroidal agents for long-term therapy if needed. Side-effects from topical glucocorticoids are related to the potency ranking of the compound and the length of use as well as the area of the body to which the drug is applied, so it is incumbent on the clinician to balance the need for a more potent steroid with the potential for side-effects. In general, ointments have a greater potential to occlude the epidermis, resulting in enhanced systemic absorption compared to creams. Side-effects from topical glucocorticoids can be divided into local and systemic. Local side-effects include the

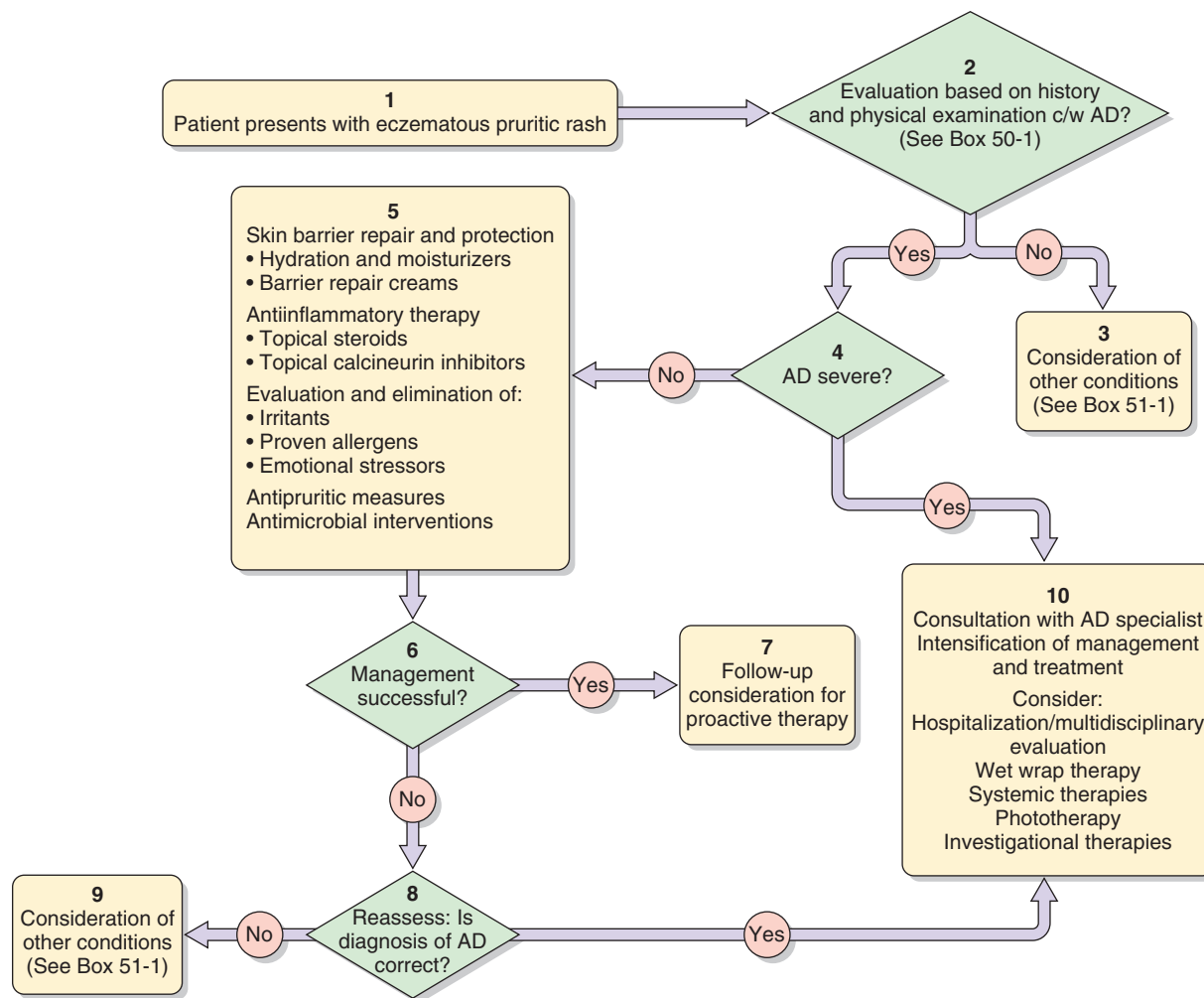

**Figure 51-1** Clinical algorithm for diagnosis and management of atopic dermatitis.

development of striae and skin atrophy.<sup>17</sup> Systemic side-effects in AD are uncommon unless high-potency steroids are used under occlusion, but adrenal suppression and cataracts have been reported.<sup>18–20</sup> However, disease activity, rather than the use of topical corticosteroids, was shown to be responsible for low basal cortisol values in patients with severe AD.<sup>21</sup> Of note, patients and caregivers continue to use topical corticosteroids suboptimally, primarily due to concerns about their use.<sup>22</sup> This may include delaying application of the medication for a number of days after the start of a flare, which contributes to suboptimal outcomes. An expert consensus from the Dermatology Working Group pointed out that ‘in an ideal world, dermatologists, dermatology nurses, ... practitioners, ... pharmacists would work together to advise and reinforce information about the correct way to apply topical corticosteroids, and to address concerns about the safety of these highly effective agents. But in the real world, expert advice, even when given, is soon forgotten ...’<sup>15</sup> Patients and caregivers need to have a basic understanding of topical corticosteroids, including their risks and benefits. Patients may erroneously assume that the potency of a topical corticosteroid is defined by the percent stated after the compound name (as discussed under ‘Education of Patients and Caregivers’ later in this chapter). At times, patients may be prescribed a high-potency corticosteroid with instructions to

discontinue it within 7 to 14 days without a plan to step down, resulting in rebound flaring of their AD. Of note, only a few topical corticosteroids have been approved for use in very young children. These include desonide and fluticasone cream down to 3 months of age, alclometasone down to 1 year of age and mometasone down to 2 years of age. Indications are typically for up to 3 to 4 weeks.

Patients with AD are often labeled as topical corticosteroid treatment failures. Reasons for this may include inadequate potency of the preparation or insufficient amount dispensed or applied, *S. aureus* superinfection, steroid allergy and possibly corticosteroid insensitivity. A much more common reason for therapeutic failure is nonadherence to the treatment regimen. As with any chronic disease, patients or caregivers often expect quick and lasting benefits and become frustrated with the relapsing nature of AD.<sup>23</sup> These factors need to be considered when faced with a patient not responding to therapy before considering alternative therapy, especially systemic treatment.

### TOPICAL CALCINEURIN INHIBITORS

Since their approval by the FDA in 2000 and 2001, respectively, the topical calcineurin inhibitors (TCIs) – tacrolimus ointment (Protopic 0.03% and 0.1%) and pimecrolimus cream (Elidel

1%) – have become well-established, effective and safe nonsteroidal treatments for pediatric AD.<sup>24</sup> They are currently indicated as second-line treatment for intermittent, noncontinuous use in children aged 2 years and older with moderate-severe AD (tacrolimus ointment 0.03%) and mild-moderate AD (pimecrolimus cream 1%). Tacrolimus ointment 0.1% is indicated for patients 16 years and older. Nevertheless, patients and caregivers frequently misunderstand their place in the treatment algorithm and have concerns about the boxed warning for these drugs. Of note, a Joint Task Force of the American College of Allergy, Asthma and Immunology and the American Academy of Allergy, Asthma and Immunology reviewed the available data and concluded that the risk/benefit ratios of tacrolimus ointment and pimecrolimus cream are similar to those of most conventional therapies for the treatment of chronic relapsing eczema.<sup>25</sup> In addition, a case-control study of a large database that identified a cohort of 293,253 patients with AD found no increased risk of lymphoma with the use of TCIs.<sup>26</sup> Children may be prescribed TCIs to replace topical corticosteroids when they are not doing well or during a flare of AD, with unrealistic expectations for this class of drugs. Patients and caregivers may not be instructed about potential side-effects, a common reason for TCIs being discontinued, and patients labeled as treatment failures. While several studies have explored the use of TCIs in children under 2 years of age<sup>27</sup> and as early intervention to reduce the incidence of flare and need for topical steroid rescue,<sup>28</sup> they would currently be considered to be off-label therapy.

## PROACTIVE THERAPY

As discussed in Chapter 50, normal appearing skin in AD is not normal; there are immune and skin barrier abnormalities, as well as *S. aureus* colonization. In patients whose eczema tends to relapse in the same location, an approach that has gained increased attention is that of proactive therapy. After a period of stabilization, topical antiinflammatory therapy is instituted in areas of previously involved but normal-appearing skin, rather than waiting for a flare of eczema in a traditional reactive approach. Studies with topical corticosteroids<sup>29–32</sup> and TCIs,<sup>33,34</sup> including in pediatric patients,<sup>35,36</sup> have shown clinical benefit with this approach. Of note, it is important to recognize that eczema first needs to be brought under control before a 2 to 3 times weekly, long-term regimen can be instituted. This approach would currently be considered off-label in the USA, but it has been approved in EU countries for children 2 years and older for up to 12 months with tacrolimus ointment and shown to be a cost-effective approach by the National Health Service of the UK.<sup>37</sup>

## Identification and Elimination of Triggering Factors

Patients with AD have hyperreactive skin and a number of different triggers including irritants, allergens, infectious agents and emotional stressors can contribute to cutaneous inflammation and flare of eczema.

### IRRITANTS

Patients with AD are more susceptible to irritants than are normal individuals. Thus it is important to identify and

eliminate or minimize exposure to irritants such as soaps or detergents, chemicals, smoke, abrasive clothing and extremes of temperature and humidity. Alcohol and astringents found in toiletries can be drying. Cleansers, ideally formulated for sensitive skin, should be used in place of soaps, especially fragranced ones. Using a liquid rather than powder detergent and adding a second rinse cycle will facilitate removal of the detergent. Recommendations regarding environmental conditions should include temperature and humidity control to avoid problems related to heat, humidity and perspiration. Every attempt should be made to allow children to be as normally active as possible. Certain sports such as swimming may be better tolerated than others that involve intense perspiration, physical contact or heavy clothing and equipment, but chlorine should be rinsed off after swimming with the aid of a cleanser and the skin lubricated. Although ultraviolet light may be beneficial to some patients with AD, sunscreens should be used to avoid sunburn. Sunscreens formulated for the face are often better tolerated.

## SPECIFIC ALLERGENS

Potential allergens can be identified by taking a careful history and carrying out selective allergy tests. Negative skin tests or serum tests for allergen-specific immunoglobulin E (IgE) have a high predictive value for ruling out suspected allergens. Positive skin or in vitro tests, particularly to foods, often do not correlate with clinical symptoms and should be confirmed with controlled food challenges and, if indicated, trials of specific elimination diets.<sup>38</sup> Avoidance of foods implicated in controlled challenges has been shown to result in clinical improvement. Infants who do not improve on formulas containing hydrolyzed proteins can be tried on amino acid formulas. However, these can add a significant financial burden for the family. Extensive elimination diets which, in some cases, can be nutritionally deficient, are rarely if ever required, because even with multiple positive allergy tests, the majority of children will react to three or fewer foods on controlled challenge. Unfortunately, patients with multiple positive allergy tests are often labeled as multiple food-allergic with no attempts to prove clinical relevance. Food challenges after getting the eczema under control and establishing a baseline for immediate, and less frequently delayed, reactions can be of immense value in managing the patient and helping the family with this stressful issue. It is noteworthy that in one retrospective study, 325 (89%) of 364 supervised oral food challenges were reported as negative.<sup>39</sup> In addition, consultation with a dietitian familiar with food allergies can be extremely helpful to ensure a nutritionally sound diet for the child and suggest practical advice to caregivers.<sup>40</sup> The Food Allergy Research & Education website ([www.foodallergy.org](http://www.foodallergy.org)) is a useful resource for patients and families with food allergy (see also Chapter 45 on food allergy).

In patients allergic to dust mites, prolonged avoidance of dust mites has been found to result in improvement of AD.<sup>41–44</sup> Avoidance measures include: using dust mite-proof casings on pillows, mattresses and box springs; washing bedding in hot water weekly; removing bedroom carpeting; and decreasing indoor humidity levels with air conditioning. Because there are many triggers that can contribute to the flare of AD, attention should be focussed on identifying and controlling the flare factors that are important to the individual patient. In addition, allergic contact dermatitis may be overlooked in children and



patch testing should be considered in children with AD (see Chapter 53).<sup>45</sup> In a study to determine the frequency of positive and relevant patch tests in children referred for patch testing in North America, of the children with a relevant positive reaction, 34.0% had a diagnosis of AD.<sup>46</sup>

### EMOTIONAL STRESSORS

AD patients often respond to frustration, embarrassment and other stressful events with increased pruritus and scratching. In some instances, scratching is simply habitual; less commonly it is associated with secondary gain. Psychologic evaluation or counseling should be considered in patients who have difficulty with emotional triggers or psychologic problems contributing to difficulty in managing their disease. Relaxation, behavioral modification or biofeedback may be helpful in patients who habitually scratch.<sup>47</sup>

### INFECTIOUS AGENTS

Children with AD often are colonized or infected with various microbial organisms including bacteria, especially *Staphylococcus aureus* (Figure 51-2), viruses including herpes simplex virus, and occasionally yeast or fungi. Methicillin-resistant *S. aureus* (MRSA) is becoming an increasingly important pathogen in patients with AD. Antistaphylococcal antibiotics are helpful in the treatment of patients who are heavily colonized or infected with *S. aureus*.<sup>48</sup> Cephalosporins or penicillinase-resistant penicillins are usually beneficial for patients who are not colonized with resistant *S. aureus* strains. Erythromycin and other macrolide antibiotics are usually of limited utility due to increasing frequency of erythromycin-resistant *S. aureus*. Topical mupirocin is useful for the treatment of localized impetiginized lesions; however, in patients with extensive skin infection, a course of systemic antibiotics is more practical. Retapamulin ointment 1%, used twice daily for 5 days, was shown to be as effective as oral cephalexin twice daily for 10 days in the treatment of patients with secondarily infected dermatitis and was well tolerated.<sup>49</sup> Use of topical neomycin, on the other hand, can result



**Figure 51-2** Patient with atopic dermatitis who is secondarily infected with *Staphylococcus aureus*. Note multiple pustules and areas of crusting. (From Weston WL, Morelli JG, Lane A, editors. Color textbook of pediatric dermatology. 3rd edn. St Louis: Mosby; 2002.)

in development of allergic contact dermatitis because neomycin is among the more common allergens causing contact dermatitis.<sup>50</sup> Treatment for nasal carriage with an intranasal antibiotic may lead to clinical improvement of AD.<sup>51</sup> MRSA may require culture and sensitivity testing to assist in appropriate antibiotic selection. However, patients and caregivers need to be instructed that the best defense against microbes is an intact skin barrier, and basic skin care principles as discussed above should be emphasized. Of note, antiinflammatory therapy alone, with either a topical corticosteroid or topical calcineurin inhibitor, has been shown to improve AD and reduce *S. aureus* colonization of the skin.<sup>52</sup>

Although antibacterial cleansers have been shown to be effective in reducing bacterial skin flora,<sup>53</sup> they may be too irritating to use on inflamed skin in AD. Baths with dilute sodium hypochlorite (bleach) may also be of benefit to AD patients, especially those with recurrent MRSA as discussed above under 'Hydration and Skin Barrier Protective Measures', although they can be irritating. Of note, a single-center controlled study, while showing clinical benefit, did not demonstrate decreased skin colonization by *S. aureus* even with combined nasal treatment with mupirocin and after 3 months of treatment.<sup>3</sup> A 2014 review discusses an approach to recurrent MRSA infections in patients with AD.<sup>54</sup> Some studies have shown that silver-impregnated clothing reduced staphylococcal colonization, improved clinical parameters and reduced topical corticosteroid use in AD.<sup>55</sup>

AD can be complicated by disseminated herpes simplex virus infection, resulting in Kaposi's varicelliform eruption or eczema herpeticum (Figure 51-3). Vesicular lesions are umbilicated, tend to crop, and often become hemorrhagic and crusted. These lesions may coalesce to large, denuded and bleeding areas that can extend over the entire body. Herpes simplex can provoke recurrent dermatitis and may be misdiagnosed as impetigo, although herpetic lesions can become superinfected by *S. aureus*.<sup>56</sup> The presence of punched-out erosions, vesicles and/or infected skin lesions that fail to respond to oral antibiotics should initiate a search for herpes simplex. This can be diagnosed by a Giemsa-stained Tzanck smear of cells scraped from the vesicle base or by viral culture or polymerase chain reaction (PCR). Test results may be falsely negative if the samples are inadequate. Ideally, vesicle fluid should be obtained



**Figure 51-3** Eczema herpeticum, the primary skin manifestation of herpes simplex in atopic dermatitis. (From Fireman P, Slavin R, editors. Atlas of allergies. 2nd edn. London: Mosby-Wolfe; 1996.)



by unroofing one or more intact vesicles. Lumbar puncture should be considered if meningitis is suspected, but the presence of infected lesions over the lumbar areas should preclude this procedure. Ophthalmology consultation should be obtained for patients with periocular or suspected eye involvement. Treatment may be with oral acyclovir for less severe infections or intravenous acyclovir for widely disseminated disease or toxic-appearing patients at 30 mg/kg/day divided every 8 hours (for patients <1 year old) or 1,500 mg/m<sup>2</sup>/day divided every 8 hours (for patients >1 year old) for 7 to 21 days, depending on the clinical course.<sup>57</sup> Valacyclovir is indicated in pediatric patients 12 years or older for treatment of herpes labialis (2 g every 12 hours for 1 day) and patients 2 to <18 years of age for treatment of chickenpox (20 mg/kg 3 times daily for 5 days) up to a maximum dose of 1 g 3 times daily. Detailed instructions on preparing a liquid suspension (including shelf life) are available under 'Extemporaneous Preparation of Oral Suspension' in the manufacturer's package insert. Of note, the suspension needs to be used within 4 weeks of being prepared. Acyclovir prophylaxis may be necessary for patients with recurrent eczema herpeticum.

In patients with AD, smallpox vaccination, or even exposure to vaccinated individuals, may cause a severe widespread skin rash called eczema vaccinatum that is similar in appearance to eczema herpeticum.<sup>58</sup> An increased risk of fatalities resulting from eczema vaccinatum has been reported in AD. Even if not fatal, eczema vaccinatum is often associated with severe scarring and lifelong complications following recovery from this illness.

Fungi may play a role in chronic inflammation of AD. There has been particular interest in the role of *Malassezia* (Pityrosporum) in AD. *Malassezia sympodialis* is a lipophilic yeast commonly present in the seborrheic areas of the skin. IgE antibodies against *M. sympodialis* are found in AD patients, most frequently in patients with a head and neck distribution of dermatitis. The potential importance of *M. sympodialis* as well as other dermatophyte infections is further supported by the reduction of AD skin severity in patients treated with antifungal agents.<sup>59</sup> However, even patients with IgE antibodies to *M. sympodialis* often respond better to topical steroids than to topical antifungal therapy, and systemic antifungal therapy may benefit AD patients through antiinflammatory properties.<sup>60</sup>

## CONTROL OF PRURITUS AND SLEEP DISTURBANCE

The treatment of pruritus in AD should be directed primarily at the underlying causes. Reduction of skin inflammation and dryness with topical glucocorticoids and skin hydration, respectively, will often symptomatically reduce pruritus. Inhaled and ingested allergens should be eliminated if documented to contribute to eczema. Systemic antihistamines act primarily by blocking the H<sub>1</sub> receptors in the dermis and thereby ameliorating histamine-induced pruritus. However, histamine is only one of many mediators that can induce pruritus of the skin, minimizing benefit from antihistamine therapy. Some antihistamines have anxiolytic agents and may offer symptomatic relief through their tranquilizing and sedative effects. Studies of newer non-sedating antihistamines have shown variable results in the effectiveness of controlling pruritus in AD patients although they may be useful in the subset of AD patients with concomitant urticaria. Because pruritus is usually worse at night, sedating antihistamines such as hydroxyzine or

diphenhydramine may offer an advantage with their soporific side-effects when used at bedtime. Doxepin hydrochloride has both tricyclic antidepressant and H<sub>1</sub>- and H<sub>2</sub>-histamine receptor blocking effects. Thus, it may be useful in treating children and adolescents who do not respond to H<sub>1</sub> sedating antihistamines. If nocturnal pruritus remains severe, short-term use of a sedative to allow adequate rest may be appropriate. Treatment of AD with topical antihistamines or topical anesthetics is not recommended because of potential cutaneous sensitization. Other treatment options for sleep disturbance used by the behavioral health clinicians in the AD program at National Jewish Health include clonidine and melatonin.

## Other Treatments

### TAR PREPARATIONS

Coal tar preparations may have antipruritic and antiinflammatory effects on the skin.<sup>61</sup> They may also have a beneficial effect on the skin barrier, as a recent study showed that coal tar can increase filaggrin protein in the skin.<sup>62</sup> Tar shampoos can be beneficial for scalp dermatitis. Tar preparations should not be used on acutely inflamed skin because this can result in skin irritation. Side-effects associated with tars include folliculitis and photosensitivity.

### PHOTOTHERAPY

Natural sunlight in moderation may be beneficial to patients with AD; however, if the sunlight occurs in the setting of high heat or humidity, triggering sweating and pruritus, it may be deleterious. Broad-band ultraviolet B, broad-band ultraviolet A, narrow-band ultraviolet B (NB-UVB) (311 nm), UVA-1 (340–400 nm) and combined UVAB phototherapy can be useful adjuncts in the treatment of AD. Of note, UVB therapy was shown to increase skin barrier proteins including filaggrin in AD.<sup>63</sup> Studies in children are limited and, in general, UV therapy should be restricted to adolescents, except in exceptional cases.<sup>1</sup> Short-term adverse effects with phototherapy may include erythema, pain, pruritus and pigmentation; long-term adverse effects include premature skin aging and cutaneous malignancies.

### SYSTEMIC THERAPY

Children who are considered candidates for systemic therapy should be evaluated by specialists in AD.<sup>1</sup> Patients with refractory AD often will respond to conventional therapy with appropriate education regarding the relapsing nature of AD and proper skin care.<sup>64</sup> In addition, other diseases with eczematous rash may need to be considered (see [Box 51-1](#)).

#### *Systemic Glucocorticoids*

The use of systemic glucocorticoids, such as oral prednisone, is rarely indicated in the treatment of chronic AD.<sup>1</sup> The dramatic clinical improvement that may occur with systemic glucocorticoids is frequently associated with a severe rebound flare of AD following the discontinuation of systemic glucocorticoids. Short courses of oral glucocorticoids may be appropriate for an acute exacerbation of AD while other treatment measures are being instituted. If a short course of oral glucocorticoids is given, it is important to taper the dosage and begin intensified

skin care, particularly with topical glucocorticoids and frequent bathing followed by application of emollients, in order to prevent rebound flaring of AD. Patients with oral steroid-dependent AD, or who are treated with frequent courses of systemic steroids, need to be evaluated for corticosteroid side-effects, including adrenal suppression, osteoporosis, cataracts and muscle weakness, and switched to other therapy.

### Cyclosporin A

Cyclosporin A (CsA) is a potent immunosuppressive drug that acts primarily on T cells by suppressing cytokine transcription. Studies, including in children, have demonstrated that patients with severe AD, refractory to conventional treatment, can benefit from short-term CsA treatment with reduced skin disease and improved quality of life.<sup>65</sup> A 1-year study of CsA (5 mg/kg/day) in a pediatric population using either intermittent or continuous treatment showed no significant differences between these two approaches with respect to efficacy or safety parameters, and a subset of patients remained in remission after treatment was stopped.<sup>66</sup> In addition, children as young as 22 months of age were shown to respond to low-dose (2.5 mg/kg/day) CsA.<sup>67</sup> Nevertheless, risks must be weighed against benefits and lab parameters, especially serum creatinine and blood pressure, monitored.<sup>1</sup>

### Azathioprine

Azathioprine is a purine analog with antiinflammatory and antiproliferative effects. It has been used for severe AD, including in children, although no controlled trials have been reported.<sup>68</sup> Myelosuppression is a significant adverse effect, although thiopurine methyl transferase levels may predict individuals at risk.<sup>1</sup>

### Mycophenolate Mofetil

Mycophenolate mofetil (MMF), a purine biosynthesis inhibitor used as an immunosuppressant in organ transplantation, has been used for treatment of refractory inflammatory skin disorders.<sup>1</sup> The drug has generally been well tolerated although herpes retinitis and dose-related bone marrow suppression have been reported. A retrospective analysis of children treated with MMF as systemic monotherapy for severe, recalcitrant AD found that of 14 patients, 4 achieved complete clearance, 4 had >90% improvement, 5 had 60–90% improvement and 1 failed to respond.<sup>69</sup> Initial responses occurred within 8 weeks (mean 4 weeks), and maximal effects were attained after 8 to 12 weeks at MMF doses of 40–50 mg/kg/day in younger children and 30–40 mg/kg/day in adolescents. MMF was well tolerated in all patients, with no infectious complications or significant lab abnormalities.

## Education of Patients and Caregivers

Education is a critical component of AD management, especially when the disease is severe or relapsing. Important components include teaching about the chronic or relapsing nature of AD, exacerbating factors and therapeutic options with risks versus benefits and prognosis. Strategies include one-on-one communication, direct demonstration with reinforcement, group discussions, classroom teaching and written materials including an AD Home Care or Action Plan. Observing the patient's or caregiver's method of treatment will often reveal fundamental errors which may explain why a patient is not

experiencing the expected therapeutic response. Patients or caregivers are often observed applying inadequate amounts of topical medications, layering therapy, thus diluting or blocking specific drugs and misunderstanding the potency of topical corticosteroids based on the misperception that corticosteroid potency is based on the percent value (e.g. 2.5% vs 0.05%), rather than on the specific corticosteroid preparation (e.g. mometasone vs hydrocortisone). AD Home Care or Action Plans are integral to the management of children with AD; without them, patients or caregivers may forget or confuse skin care recommendations.<sup>47</sup> These plans should fit the child's and family's needs and should be reviewed and modified at all follow-up visits.

Providing patients and caregivers with appropriate educational resources is an important component of management. Educational brochures and videos can be obtained from the National Eczema Association (800-818-7546 or [www.nationaleczema.org](http://www.nationaleczema.org)). Information, instruction sheets and brochures including the comprehensive booklet, *Understanding Atopic Dermatitis*, are available from National Jewish Health Lung Line (800 222-LUNG or [www.nationaljewish.org](http://www.nationaljewish.org)) as well as from national organizations such as the American Academy of Allergy, Asthma & Immunology ([www.aaaai.org](http://www.aaaai.org)) or the American Academy of Dermatology ([www.aad.org](http://www.aad.org)).

## Wet Wrap Therapy

Wet wrap therapy has been used successfully as part of a step-up therapy regimen for treating severe or recalcitrant AD for over two decades.<sup>70</sup> This therapeutic intervention can improve penetration of topical medications, reduce pruritus and inflammation and act as a barrier against trauma from scratching.<sup>47</sup> A study of wet wraps demonstrated recovery of the epidermal barrier with clinical improvement associated with release of lamellar body and restoration of intercellular lipid lamellar structure.<sup>71</sup> Of note, 1 week after discontinuation of wet wraps, increased water content and decreased transepidermal water loss (TEWL) was still maintained. Wet wrap therapy has been shown to benefit patients during acute flares of AD.<sup>72</sup> This study points to the usefulness of this intervention in acute AD flares and suggests that the time for topical corticosteroid application may be shortened. A technique used successfully at National Jewish Health in Denver employs clothing, such as long underwear and cotton socks, selectively wetted based on distribution of the patient's eczema, applied over an undiluted layer of topical corticosteroids with a dry layer of clothing on top.<sup>47</sup> Treating facial eczema requires nursing skills with wet, followed by dry, gauze expertly applied with spaces for eyes and mouth carefully cut out and secured with a dressing such as surgical Spandage® (Figure 51-4). A DVD demonstrating wrap therapy can be purchased through the Professional Education Department at National Jewish Health ([www.nationaljewish.org](http://www.nationaljewish.org)). Wraps may be removed when they dry out (after approximately 2 hours), however it is often practical to apply them at bedtime and most children are able to sleep with them on. Overuse of wet wraps may result in chilling or maceration of the skin and may be complicated by secondary infection. However, a controlled study of wet wrap therapy with topical corticosteroids found that *S. aureus* colonization was decreased with this intervention.<sup>73</sup> While use of wet wrap therapy over topical calcineurin inhibitors is not indicated on current package labeling, this approach is used 'off-label' by clinicians. Wet wrap therapy



**Figure 51-4** Facial eczema treated with wet, followed by dry, gauze, and secured with a dressing such as surgical Spandage®. (Reprinted from Boguniewicz M, Nicol N, Kelsay K, et al. A multidisciplinary approach to evaluation and treatment of atopic dermatitis. *Semin Cutan Med Surg* 2008;27:115–27, with permission from Elsevier.)

should be thought of as an acute crisis intervention, not as part of maintenance therapy, although occasionally it can be used on a more chronic basis to select areas of resistant dermatitis with appropriate monitoring. An evidence-based critical review of wet wrap therapy in children concluded, with a grade C recommendation, that: (1) wet wrap therapy using cream or ointment and a double layer of cotton bandages, with a moist first layer and a dry second layer, is an efficacious short-term intervention treatment in children with severe and/or refractory AD; (2) the use of wet wrap dressings with diluted topical corticosteroids is a more efficacious short-term intervention treatment in children with severe and/or refractory AD than wet wrap dressings with emollients only; (3) the use of wet wrap dressings with diluted topical corticosteroids for up to 14 days is a safe intervention treatment in children with severe and/or refractory AD, with temporary systemic bioactivity of the corticosteroids as the only reported serious side-effect; (4) lowering the absolute amount of applied topical corticosteroid to once daily application and further dilution of the product can reduce the risk of systemic bioactivity.<sup>74</sup> Recently, the largest controlled study of wet wrap therapy in children using a validated scoring tool and patient questionnaire showed that in patients with moderate to severe AD, SCORAD improved significantly and, importantly, the benefit of this intervention could be demonstrated one month after discharge from the program, even though the treatment itself was discontinued before discharge (used for an average of 4 days).<sup>75</sup> Importantly, none of these patients required treatment with a systemic immunosuppressive agent.

## Multidisciplinary Approach to Atopic Dermatitis

Given the complex nature of AD, its relapsing course and incompletely understood pathogenesis, a significant number of patients have suboptimal outcomes with their prescribed treatment regimens. In addition, there is a significant impact on the quality of life of patients and families that leads to frustration

and often a search for alternative therapies, which may not be in the best interest of the child. While children with AD of all severities could benefit from a multidisciplinary approach, those who especially should be considered candidates include those failing conventional therapy, those with recurrent skin infections, those diagnosed with multiple food allergies, those whose disease is having a significant impact on their or their family's quality of life, those with concerns about medication side-effects and those with need for in-depth education. The significant and sustained clinical improvement often seen in patients treated with a multidisciplinary approach may be due, in large part, to in-depth, hands-on education, along with changes in environmental exposures, reduction in stressors and assurance of adherence with therapy. Of note, a high percentage of these patients experience significant improvement, even when treated with medications that previously were believed to be ineffective, when the treatment is integrated into a comprehensive and individualized management program.

The Atopic Dermatitis Program (ADP) at National Jewish Health in Denver, Colorado, consists of a team of pediatric allergist-immunologists with extensive experience in basic and clinical research in AD, a nurse practitioner/dermatology clinical specialist, pediatric psychiatrist, child psychologists, allergy-immunology fellows-in-training, physician assistants, nurse educators, child life specialists, creative art therapist, social workers, dietitians and rehabilitation therapists.<sup>47</sup> Dermatologists are available for consultation if the diagnosis of AD is in question or phototherapy is being considered. Patients undergo comprehensive evaluation and treatment that is tailored to their needs and the goals of the family. Our ADP provides single-day consultations, multi-day outpatient clinic visits, rarely inpatient hospitalization or a day program for more extensive evaluation, education and treatment typically over 5 to 14 days. In the controlled environment of the day program, patients and caregivers interact with members of the multidisciplinary team and, importantly, with other patients and families in group meetings and informal settings. In addition, sleep disturbance and response to interventions can be evaluated with overnight observation.<sup>76</sup>

## ALLERGEN IMMUNOTHERAPY

Allergen-specific immunotherapy (AIT) has been added as a therapeutic consideration in the most recent AD Practice Parameter Update for selected AD patients with environmental allergies, based on studies with house dust mite immunotherapy.<sup>1</sup> Most of the studies have been done in adult patients and, anecdotally, patients on AIT may have flares of their eczema with allergen injections. Well-controlled studies in children with AD are still required to determine the role for AIT in this disease. In addition, preliminary studies with sublingual immunotherapy suggest a role for a subset of children with AD sensitized to dust mite allergen,<sup>77</sup> but again these data need to be reproduced in a larger pediatric population, especially in light of the natural history of AD for different subsets of patients.

## Investigational or Unproven Therapy

### INTRAVENOUS IMMUNOGLOBULIN

High-dose intravenous immunoglobulin (IVIG) could have immunomodulatory effects in AD. In addition, IVIG could



interact directly with microbes or toxins involved in the pathogenesis of AD. IVIG has been shown to contain high concentrations of staphylococcal toxin-specific antibodies that inhibit the *in vitro* activation of T cells by staphylococcal toxins.<sup>78</sup>

Treatment of severe refractory AD with IVIG has yielded conflicting results. Studies have not been controlled and have involved small numbers of patients.<sup>79,80</sup> Children appear to have a better response than adults, including to IVIG as monotherapy, and the duration of response was also shown to be more prolonged in children. However, additional controlled studies are needed to establish efficacy in a more definitive manner.

## INTERFERON- $\gamma$

IFN- $\gamma$  is known to suppress IgE responses and down-regulate Th2 cell proliferation and function. Several studies of patients with AD, including a multicenter, double-blinded, placebo-controlled trial, have demonstrated that treatment with recombinant IFN- $\gamma$  results in clinical improvement.<sup>81</sup> Reduction in clinical severity of AD was correlated with the ability of IFN- $\gamma$  to decrease total circulating eosinophil counts. Influenza-like symptoms are commonly observed side-effects seen early in the treatment course.

## PROBIOTICS

Data from one meta-analysis suggest a modest role for probiotics in children with moderately severe disease in reducing the Scoring of Atopic Dermatitis Severity Index score (mean change from baseline,  $-3.01$ ; 95% confidence interval,  $-5.36$  to  $-0.66$ ;  $P = .01$ ).<sup>82</sup> Duration of probiotic administration, age and type of probiotic used did not affect outcome. Another meta-analysis found that current evidence is more convincing for probiotic efficacy in prevention rather than treatment of pediatric AD.<sup>83</sup> On the other hand, supplementation with *Lactobacillus GG* during pregnancy and early infancy neither reduced the incidence of AD nor altered the severity of AD in affected children, but was associated with an increased rate of recurrent episodes of wheezing bronchitis.<sup>84</sup> A Cochrane review concluded that probiotics are not an effective treatment for eczema in children and that probiotic treatment carries a small risk of adverse events.<sup>85</sup> In contrast, a more recent meta-analysis of randomized controlled trials through 2011 that attempted to overcome some of the limitations of earlier reviews found a reduction of approximately 20% in the incidence of AD and IgE-associated AD in infants and children with probiotic use.<sup>86</sup> To add to the continued uncertainty, a study in pregnant women and infants up to age 6 months given a multistrain probiotic did not show any difference in diagnosis of eczema at 2 years compared to placebo.<sup>87</sup> However, the frequency of allergic sensitization and allergic eczema (defined as eczema with one or more positive allergy skin tests) was significantly reduced.

## VITAMIN D

Vitamin D deficiency is being increasingly recognized in the US population and may play a role in various allergic illnesses.<sup>88</sup> Of interest, vitamin D may play an important role in regulation of antimicrobial peptides in keratinocytes as discussed in Chapter 50.<sup>89</sup> A trial with oral vitamin D supports this hypothesis.<sup>90</sup> In one small pediatric study, children with AD were treated with

oral vitamin D in a randomized, controlled trial. Investigator Global Assessment (IGA) score improved by 1 IGA category in 4 of 5 subjects treated with vitamin D versus 1 of 6 on placebo. Similar improvements were seen for change in the eczema area and severity index (EASI) score.<sup>91</sup> The updated Practice Parameter states that patients with AD may benefit from supplementation with vitamin D, particularly if they have low vitamin D levels or low dietary intake.<sup>1</sup>

## OMALIZUMAB

Anecdotal reports suggest clinical benefit in some patients with AD, including children treated for their asthma with monoclonal anti-IgE (omalizumab) subcutaneous injections.<sup>92</sup> Adult patients with severe AD and significantly elevated serum IgE levels did not show benefit when omalizumab was used as monotherapy.<sup>93</sup> In contrast, significant improvement in three adolescent patients was observed when omalizumab was added to the usual therapy.<sup>94</sup> In addition, in an open study of 7 patients (aged 6–19 years) with severe AD treated with omalizumab, baseline SCORAD was 75.4 (53–96.2) with mean serum IgE 16,007 IU/L (7,520–35,790 IU/L).<sup>95</sup> After 12 months of treatment, mean SCORAD was 30.0 (16.2–43), a mean improvement of 45.6 (31.6–59.6;  $P < .0005$ ). Specific markers have not been found to identify potential responders although a recent study suggested that adult AD patients who respond are wild type for filaggrin mutations.<sup>96</sup> At present, omalizumab remains an investigational therapy in AD.

## Conclusions

AD is a common, genetically transmitted inflammatory skin disease frequently found in association with respiratory allergy. Key management concepts include protection of the skin barrier, skin hydration, avoidance of irritants and proven allergic triggers and effective use of topical antiinflammatory agents (Box 51-2). Education of patients and caregivers is an essential part of treating AD patients of all levels of severity and a multidisciplinary approach to management may be the best approach for a number of patients. Better understanding of the complex genetic and immunoregulatory abnormalities underlying AD may allow for development of more specific treatments and suggest new paradigms for managing this disease.

### BOX 51-2 THERAPEUTIC PRINCIPLES

#### ATOPIC DERMATITIS

- Proper skin hydration and moisturizers are needed to repair and help preserve skin barrier function.
- Topical antiinflammatory therapy can be used for both treatment of acute flares and prevention of relapses.
- Avoidance of proven food and inhalant allergens may prevent or lessen flares.
- Measures to decrease microbial colonization can improve atopic dermatitis.
- Sedating antihistamines may provide symptomatic relief through sedating side-effects.
- Addressing the psychosocial aspects of a chronic, relapsing illness and providing education with written skin care instructions can lead to improved outcomes.



## Helpful Websites

National Jewish Health ([www.nationaljewish.org](http://www.nationaljewish.org))  
 The National Eczema Association ([www.nationaleczema.org](http://www.nationaleczema.org))  
 The American Academy of Allergy, Asthma & Immunology  
 ([www.aaaai.org](http://www.aaaai.org))  
 The American Academy of Dermatology ([www.aad.org](http://www.aad.org))

The complete reference list can be found on the companion Expert Consult website at <http://www.expertconsult.inkling.com>.

## KEY REFERENCES

- Schneider L, Tilles S, Lio P, Boguniewicz M, Beck L, LeBovidge J, et al. Atopic dermatitis: a practice parameter update 2012. *J Allergy Clin Immunol* 2013;131:295-9 e1-27.
- Fonacier L, Spengel J, Charlesworth EN, Weldon D, Beltrani V, Bernhisel-Broadbent J, et al. Report of the Topical Calcineurin Inhibitor Task Force of the American College of Allergy, Asthma and Immunology and the American Academy of Allergy, Asthma and Immunology. *J Allergy Clin Immunol* 2005;115:1249-53.
- Berth-Jones J, Damstra RJ, Golsch S, Livden JK, Van Hooteghem O, Allegra F, et al. Twice weekly fluticasone propionate added to emollient maintenance treatment to reduce risk of relapse in atopic dermatitis: randomised, double blind, parallel group study. *BMJ* 2003;326:1367.
- Thaci D, Reitamo S, Gonzalez Ensenat MA, Moss C, Boccaletti V, Cainelli T, et al. Proactive disease management with 0.03% tacrolimus ointment for children with atopic dermatitis: results of a randomized, multicentre, comparative study. *Br J Dermatol* 2008;159:1348-56.
- Bergmann MM, Caubet JC, Boguniewicz M, Eigenmann PA. Evaluation of food allergy in patients with atopic dermatitis. *J Allergy Clin Immunol Pract* 2013;1:22-8.
- Fleischer DM, Bock SA, Spears GC, Wilson CG, Miyazawa NK, Gleason MC, et al. Oral food challenges in children with a diagnosis of food allergy. *J Pediatr* 2011;158:578-83.
- Boguniewicz M, Nicol N, Kelsay K, Leung DY. A multidisciplinary approach to evaluation and treatment of atopic dermatitis. *Semin Cutan Med Surg* 2008;27:115-27.
- Ong PY. Recurrent MRSA skin infections in atopic dermatitis. *J Allergy Clin Immunol Pract* 2014;2:396-9.
- Boguniewicz M, Leung DY. The ABC's of managing patients with severe atopic dermatitis. *J Allergy Clin Immunol* 2013;132:511-2.e5.
- Nicol NH, Boguniewicz M, Strand M, Klinnert MD. Wet wrap therapy in children with moderate to severe atopic dermatitis in a multidisciplinary treatment program. *J Allergy Clin Immunol Pract* 2014;2:400-6.

## REFERENCES

- Schneider L, Tilles S, Lio P, Boguniewicz M, Beck L, LeBovidge J, et al. Atopic dermatitis: a practice parameter update 2012. *J Allergy Clin Immunol* 2013;131:295-9 e1-27.
- McLear MA, Irvine AD. The multifunctional role of filaggrin in allergic skin disease. *J Allergy Clin Immunol* 2013;131:280-91.
- Huang JT, Abrams M, Tloutan B, Rademaker A, Paller AS. Treatment of *Staphylococcus aureus* colonization in atopic dermatitis decreases disease severity. *Pediatrics* 2009;123:e808-14.
- Loden M. Biophysical properties of dry atopic and normal skin with special reference to effects of skin care products. *Acta Derm Venereol Suppl (Stockh)* 1995;192:1-48.
- Loden M, Andersson AC, Lindberg M. Improvement in skin barrier function in patients with atopic dermatitis after treatment with a moisturizing cream (Canoderm). *Br J Dermatol* 1999;140:264-7.
- Hanifin JM, Hebert AA, Mays SR. Effects of a low-potency corticosteroid lotion plus a moisturizing regimen in the treatment of atopic dermatitis. *Curr Ther Res* 1998;59:227-33.
- Lucky AW, Leach AD, Laskarzewski P, Wenck H. Use of an emollient as a steroid-sparing agent in the treatment of mild to moderate atopic dermatitis in children. *Pediatr Dermatol* 1997;14:321-4.
- Johnson AW. Overview: fundamental skin care – protecting the barrier. *Dermatol Ther* 2004;17(Suppl. 1):1-5.
- Macheleidt O, Kaiser HW, Sandhoff K. Deficiency of epidermal protein-bound omega-hydroxyceramides in atopic dermatitis. *J Invest Dermatol* 2002;119:166-73.
- Chamlin SL, Kao J, Frieden IJ, Sheu MY, Fowler AJ, Fluhr JW, et al. Ceramide-dominant barrier repair lipids alleviate childhood atopic dermatitis: changes in barrier function provide a sensitive indicator of disease activity. *J Am Acad Dermatol* 2002;47:198-208.
- Elias PM, Hatano Y, Williams ML. Basis for the barrier abnormality in atopic dermatitis: outside-inside-outside pathogenic mechanisms. *J Allergy Clin Immunol* 2008;121:1337-43.
- Boguniewicz M, Zeichner JA, Eichenfield LF, Hebert AA, Jarratt M, Lucky AW, et al. MAS063DP is effective monotherapy for mild to moderate atopic dermatitis in infants and children: a multicenter, randomized, vehicle-controlled study. *J Pediatr* 2008;152:854-9.
- Eberlein B, Eicke C, Reinhardt HW, Ring J. Adjuvant treatment of atopic eczema: assessment of an emollient containing N-palmitoylethanolamine (ATOPA study). *J Eur Acad Dermatol Venereol* 2008;22:73-82.
- Long CC, Mills CM, Finlay AY. A practical guide to topical therapy in children. *Br J Dermatol* 1998;138:293-6.
- Bewley A. Expert consensus: time for a change in the way we advise our patients to use topical corticosteroids. *Br J Dermatol* 2008;158:917-20.
- Niemeier V, Kupfer J, Schill WB, Gieler U. Atopic dermatitis – topical therapy: do patients apply much too little? *J Dermatolog Treat* 2005;16:95-101.
- Luger TA, Lahfa M, Folster-Holst R, Gulliver WP, Allen R, Molloy S, et al. Long-term safety and tolerability of pimecrolimus cream 1% and topical corticosteroids in adults with moderate to severe atopic dermatitis. *J Dermatolog Treat* 2004;15:169-78.
- Gilbertson EO, Spellman MC, Piacquadio DJ, Mulford MI. Super potent topical corticosteroid use associated with adrenal suppression: clinical considerations. *J Am Acad Dermatol* 1998;38:318-21.
- Ellison JA, Patel L, Ray DW, David TJ, Clayton PE. Hypothalamic-pituitary-adrenal function and glucocorticoid sensitivity in atopic dermatitis. *Pediatrics* 2000;105:794-9.
- Kane D, Barnes L, Fitzgerald O. Topical corticosteroid treatment: systemic side-effects. *Br J Dermatol* 2003;149:417.
- Haeck IM, Timmer-de Mik L, Lentjes EG, Buskens E, Hijnen DJ, Guikers C, et al. Low basal serum cortisol in patients with severe atopic dermatitis: potent topical corticosteroids wrongfully accused. *Br J Dermatol* 2007;156:979-85.
- Charman CR, Morris AD, Williams HC. Topical corticosteroid phobia in patients with atopic eczema. *Br J Dermatol* 2000;142:931-6.
- Zuberbier T, Orlov SJ, Paller AS, Taieb A, Allen R, Hernanz-Hermosa JM, et al. Patient perspectives on the management of atopic dermatitis. *J Allergy Clin Immunol* 2006;118:226-32.
- Orlov SJ. Topical calcineurin inhibitors in pediatric atopic dermatitis: a critical analysis of current issues. *Paediatr Drugs* 2007;9:289-99.
- Fonacier L, Spengel J, Charlesworth EN, Weldon D, Beltrani V, Bernhisel-Broadbent J, et al. Report of the Topical Calcineurin Inhibitor Task Force of the American College of Allergy, Asthma and Immunology and the American Academy of Allergy, Asthma and Immunology. *J Allergy Clin Immunol* 2005;115:1249-53.
- Arellano FM, Wentworth CE, Arana A, Fernández C, Paul CF. Risk of lymphoma following exposure to calcineurin inhibitors and topical steroids in patients with atopic dermatitis. *J Invest Dermatol* 2007;127:808-16.
- Kapp A, Papp K, Bingham A, Fölster-Holst R, Ortonne JP, Potter PC, et al. Long-term management of atopic dermatitis in infants with topical pimecrolimus, a nonsteroid antiinflammatory drug. *J Allergy Clin Immunol* 2002;110:277-84.
- Boguniewicz M, Eichenfield LF, Hultsch T. Current management of atopic dermatitis and interruption of the atopic march. *J Allergy Clin Immunol* 2003;112:S140-50.
- Van Der Meer JB, Glazenburg EJ, Mulder PG, Eggink HF, Coenraads PJ. The management of moderate to severe atopic dermatitis in adults with topical fluticasone propionate. The Netherlands Adult Atopic Dermatitis Study Group. *Br J Dermatol* 1999;140:1114-21.
- Hanifin J, Gupta AK, Rajagopalan R. Intermittent dosing of fluticasone propionate cream for reducing the risk of relapse in atopic dermatitis patients. *Br J Dermatol* 2002;147:528-37.
- Berth-Jones J, Damstra RJ, Golsch S, Livden JK, Van Hoogheem O, Allegra F, et al. Twice weekly fluticasone propionate added to emollient maintenance treatment to reduce risk of relapse in atopic dermatitis: randomised, double blind, parallel group study. *BMJ* 2003;326:1367.
- Peserico A, Stadtler G, Sebastian M, Fernandez RS, Vick K, Bieber T. Reduction of relapses of atopic dermatitis with methylprednisolone aceponate cream twice weekly in addition to maintenance treatment with emollient: a multicentre, randomized, double-blind, controlled study. *Br J Dermatol* 2008;158:801-7.
- Wollenberg A, Reitamo S, Girolomoni G, Lahfa M, Ruzicka T, Healy E, et al. Proactive treatment of atopic dermatitis in adults with 0.1% tacrolimus ointment. *Allergy* 2008;63:742-50.
- Breneman D, Fleischer AB Jr, Abramovits W, Zeichner J, Gold MH, Kirsner RS, et al. Intermittent therapy for flare prevention and long-term disease control in stabilized atopic dermatitis: a randomized comparison of 3-times-weekly applications of tacrolimus ointment versus vehicle. *J Am Acad Dermatol* 2008;58:990-9.
- Thaci D, Reitamo S, Gonzalez Ensenat MA, Moss C, Boccaletti V, Cainelli T, et al. Proactive disease management with 0.03% tacrolimus ointment for children with atopic dermatitis: results of a randomized, multicentre, comparative study. *Br J Dermatol* 2008;159:1348-56.
- Paller AS, Eichenfield LF, Kirsner RS, Shull T, Jaracz E, Simpson EL, et al. Three times weekly tacrolimus ointment reduces relapse in stabilized atopic dermatitis: a new paradigm for use. *Pediatrics* 2008;122:e1210-18.
- Healy E, Bentley A, Fidler C, Chambers C. Cost-effectiveness of tacrolimus ointment in adults and children with moderate and severe atopic dermatitis: twice-weekly maintenance treatment vs standard twice-daily reactive treatment of exacerbations from a third party payer (U.K. National Health Service) perspective. *Br J Dermatol* 2011;164:387-95.
- Bergmann MM, Caubet JC, Boguniewicz M, Eigenmann PA. Evaluation of food allergy in patients with atopic dermatitis. *J Allergy Clin Immunol Pract* 2013;1:22-8.
- Fleischer DM, Bock SA, Spears GC, Wilson CG, Miyazawa NK, Gleason MC, et al. Oral food challenges in children with a diagnosis of food allergy. *J Pediatr* 2011;158:578-83.
- Boguniewicz M, Moore N, Paranto K. Allergic diseases, quality of life and the role of the dietitian. *Nutr Today* 2008;43:6-10.
- Tan BB, Weald D, Strickland I, Friedmann PS. Double-blind controlled trial of effect of household-mite allergen avoidance on atopic dermatitis. *Lancet* 1996;347:15-18.
- Ricci G, Patrizi A, Specchia F, Menna L, Bottau P, D'Angelo V, et al. Effect of house dust mite avoidance measures in children with atopic dermatitis. *Br J Dermatol* 2000;143:379-84.
- Holm L, Bengtsson A, van Hage-Hamsten M, Ohman S, Scheynius A. Effectiveness of occlusive bedding in the treatment of atopic dermatitis: a placebo-controlled trial of 12 months' duration. *Allergy* 2001;56:152-8.
- Arlian LG, Platts-Mills TA. The biology of dust mites and the remediation of mite allergens in allergic disease. *J Allergy Clin Immunol* 2001;107:S406-13.
- Mailhol C, Lauwers-Cances V, Rancé F, Paul C, Giordano-Labadie F. Prevalence and risk factors for allergic contact dermatitis to topical treatment in atopic dermatitis: a study in 641 children. *Allergy* 2009;64:801-6.
- Zug KA, McGinley-Smith D, Warshaw EM, Taylor JS, Rietschel RL, Maibach HI, et al. Contact allergy in children referred for patch testing: North American Contact Dermatitis Group data, 2001-2004. *Arch Dermatol* 2008;144:1329-36.
- Boguniewicz M, Nicol N, Kelsay K, Leung DY. A multidisciplinary approach to evaluation and treatment of atopic dermatitis. *Semin Cutan Med Surg* 2008;27:115-27.

48. Boguniewicz M, Sampson H, Leung SB, Harbeck R, Leung DY. Effects of cefuroxime axetil on *Staphylococcus aureus* colonization and superantigen production in atopic dermatitis. *J Allergy Clin Immunol* 2001;108:651–2.
49. Parish LC, Jorizzo JL, Breton JJ, Hirman JW, Scangarella NE, Shawar RM, et al. Topical retapamulin ointment (1%, wt/wt) twice daily for 5 days versus oral cephalexin twice daily for 10 days in the treatment of secondarily infected dermatitis: results of a randomized controlled trial. *J Am Acad Dermatol* 2006;55:1003–13.
50. Albert MR, Gonzalez S, Gonzalez E. Patch testing reactions to a standard series in 608 patients tested from 1990 to 1997 at Massachusetts General Hospital. *Am J Contact Dermat* 1998;9:207–11.
51. Luber H, Amornsiripanch S, Lucky AW. Mupirocin and the eradication of *Staphylococcus aureus* in atopic dermatitis. *Arch Dermatol* 1988;124:853–4.
52. Hung SH, Lin YT, Chu CY, Lee CC, Liang TC, Yang YH, et al. *Staphylococcus* colonization in atopic dermatitis treated with fluticasone or tacrolimus with or without antibiotics. *Ann Allergy Asthma Immunol* 2007;98:51–6.
53. Stalder JF, Fleury M, Sourisse M, Allavoine T, Chalamet C, Brosset P, et al. Comparative effects of two topical antiseptics (chlorhexidine vs KMnO<sub>4</sub>) on bacterial skin flora in atopic dermatitis. *Acta Derm Venereol Suppl (Stockh)* 1992;176:132–4.
54. Ong PY. Recurrent MRSA skin infections in atopic dermatitis. *J Allergy Clin Immunol Pract* 2014;2:396–9.
55. Gauger A, Fischer S, Mempel M, Schaefer T, Foelster-Holst R, Abeck D, et al. Efficacy and functionality of silver-coated textiles in patients with atopic eczema. *J Eur Acad Dermatol Venereol* 2006;20:534–41.
56. Bork K, Brauninger W. Increasing incidence of eczema herpeticum: analysis of seventy-five cases. *J Am Acad Dermatol* 1988;19:1024–9.
57. Wollenberg A, Wetzel S, Burgdorf WH, Haas J. Viral infections in atopic dermatitis: pathogenic aspects and clinical management. *J Allergy Clin Immunol* 2003;112:667–74.
58. Vora S, Damon I, Fulginiti V, Weber SG, Kahana M, Stein SL, et al. Severe eczema vaccinatum in a household contact of a smallpox vaccinee. *Clin Infect Dis* 2008;46:1555–61.
59. Back O, Scheynius A, Johansson SG. Ketoconazole in atopic dermatitis: therapeutic response is correlated with decrease in serum IgE. *Arch Dermatol Res* 1995;287:448–51.
60. Boguniewicz M, Schmid-Grendelmeier P, Leung DY. Atopic dermatitis. *J Allergy Clin Immunol* 2006;118:40–3.
61. Langeveld-Wildschut EG, Riedl H, Thepen T, Bihari IC, Bruijnzeel PL, Bruijnzeel-Koomen CA. Modulation of the atopy patch test reaction by topical corticosteroids and tar. *J Allergy Clin Immunol* 2000;106:737–43.
62. van den Bogaard EH, Bergboer JG, Vonk-Bergers M, van Vlijmen-Willems IM, Hato SV, van der Valk PG, et al. Coal tar induces AHR-dependent skin barrier repair in atopic dermatitis. *J Clin Invest* 2013;123:917–27.
63. Tintle S, Shemer A, Suárez-Fariñas M, Fujita H, Gilleaudeau P, Sullivan-Whalen M, et al. Reversal of atopic dermatitis with narrow-band UVB phototherapy and biomarkers for therapeutic response. *J Allergy Clin Immunol* 2011;128:583–93 e1–4.
64. Boguniewicz M, Leung DY. The ABC's of managing patients with severe atopic dermatitis. *J Allergy Clin Immunol* 2013;132:511–2 e5.
65. Berth-Jones J, Finlay AY, Zaki I, Tan B, Goodyear H, Lewis-Jones S, et al. Cyclosporine in severe childhood atopic dermatitis: a multicenter study. *J Am Acad Dermatol* 1996;34:1016–21.
66. Harper JJ, Ahmed I, Barclay G, Lacour M, Hoeger P, Cork MJ, et al. Cyclosporin for severe childhood atopic dermatitis: short course versus continuous therapy. *Br J Dermatol* 2000;142:52–8.
67. Bunikowski R, Staab D, Kussebi F, Bräutigam M, Weidinger G, Renz H, et al. Low-dose cyclosporin A microemulsion in children with severe atopic dermatitis: clinical and immunological effects. *Pediatr Allergy Immunol* 2001;12:216–23.
68. Murphy LA, Atherton DJ. Azathioprine as a treatment for severe atopic eczema in children with a partial thiopurine methyl transferase (TPMT) deficiency. *Pediatr Dermatol* 2003;20:531–4.
69. Heller M, Shin HT, Orlow SJ, Schaffer JV. Mycophenolate mofetil for severe childhood atopic dermatitis: experience in 14 patients. *Br J Dermatol* 2007;157:127–32.
70. Nicol NH. Atopic dermatitis: the (wet) wrap-up. *Am J Nurs* 1987;87:1560–3.
71. Lee JH, Lee SJ, Kim D, Bang D. The effect of wet-wrap dressing on epidermal barrier in patients with atopic dermatitis. *J Eur Acad Dermatol Venereol* 2007;21:1360–8.
72. Foelster-Holst R, Nagel F, Zoellner P, Spaeth D. Efficacy of crisis intervention treatment with topical corticosteroid prednicarbat with and without partial wet-wrap dressing in atopic dermatitis. *Dermatology* 2006;212:66–9.
73. Schnopp C, Holtmann C, Stock S, Remling R, Fölster-Holst R, Ring J, et al. Topical steroids under wet-wrap dressings in atopic dermatitis: a vehicle-controlled trial. *Dermatology* 2002;204:56–9.
74. Devillers AC, Oranje AP. Efficacy and safety of 'wet-wrap' dressings as an intervention treatment in children with severe and/or refractory atopic dermatitis: a critical review of the literature. *Br J Dermatol* 2006;154:579–85.
75. Nicol NH, Boguniewicz M, Strand M, Klinnert MD. Wet wrap therapy in children with moderate to severe atopic dermatitis in a multidisciplinary treatment program. *J Allergy Clin Immunol Pract* 2014;2:400–6.
76. Bender BG, Ballard R, Canonio B, Murphy JR, Leung DY. Disease severity, scratching, and sleep quality in patients with atopic dermatitis. *J Am Acad Dermatol* 2008;58:145–20.
77. Pajno GB, Caminiti L, Vita D, Barberio G, Salzano G, Lombardo F, et al. Sublingual immunotherapy in mite-sensitized children with atopic dermatitis: a randomized, double-blind, placebo-controlled study. *J Allergy Clin Immunol* 2007;120:164–70.
78. Takei S, Arora YK, Walker SM. Intravenous immunoglobulin contains specific antibodies inhibitory to activation of T cells by staphylococcal toxin superantigens [see comment]. *J Clin Invest* 1993;91:602–7.
79. Wakim M, Alazard M, Yajima A, Speights D, Saxon A, Stiehm ER. High dose intravenous immunoglobulin in atopic dermatitis and hyper-IgE syndrome. *Ann Allergy Asthma Immunol* 1998;81:153–8.
80. Jolles S. A review of high-dose intravenous immunoglobulin treatment for atopic dermatitis. *Clin Exp Dermatol* 2002;27:3–7.
81. Hanifin JM, Schneider LC, Leung DY, Ellis CN, Jaffe HS, Izu AE, et al. Recombinant interferon gamma therapy for atopic dermatitis. *J Am Acad Dermatol* 1993;28:189–97.
82. Michail SK, Stolfi A, Johnson T, Onady GM. Efficacy of probiotics in the treatment of pediatric atopic dermatitis: a meta-analysis of randomized controlled trials. *Ann Allergy Asthma Immunol* 2008;101:508–16.
83. Lee J, Seto D, Bielory L. Meta-analysis of clinical trials of probiotics for prevention and treatment of pediatric atopic dermatitis. *J Allergy Clin Immunol* 2008;121:116–21 e111.
84. Kopp MV, Hennemuth I, Heinzmann A, Urbanek R. Randomized, double-blind, placebo-controlled trial of probiotics for primary prevention: no clinical effects of *Lactobacillus GG* supplementation. *Pediatrics* 2008;121:e850–6.
85. Boyle RJ, Bath-Hextall FJ, Leonardi-Bee J, Murrell DF, Tang ML. Probiotics for treating eczema. *Cochrane Database Syst Rev* 2008;4:CD006135.
86. Pelucchi C, Chatenoud L, Turati F, Galeone C, Moja L, Bach JF, et al. Probiotics supplementation during pregnancy or infancy for the prevention of atopic dermatitis: a meta-analysis. *Epidemiology* 2012;23:402–14.
87. Allen SJ, Jordan S, Storey M, Thornton CA, Gravenor MB, Garaiova I, et al. Probiotics in the prevention of eczema: a randomised controlled trial. *Arch Dis Child* 2014;99:1014–9.
88. Oren E, Banerji A, Camargo CA Jr. Vitamin D and atopic disorders in an obese population screened for vitamin D deficiency. *J Allergy Clin Immunol* 2008;121:533–4.
89. Schaubert J, Gallo RL. Antimicrobial peptides and the skin immune defense system. *J Allergy Clin Immunol* 2008;122:261–6.
90. Hata TR, Kotol P, Jackson M, Nguyen M, Paik A, Udall D, et al. Administration of oral vitamin D induces cathelicidin production in atopic individuals. *J Allergy Clin Immunol* 2008;122:829–31.
91. Sidbury R, Sullivan AF, Thadhani RI, Camargo CA Jr. Randomized controlled trial of vitamin D supplementation for winter-related atopic dermatitis in Boston: a pilot study. *Br J Dermatol* 2008;159:245–7.
92. Vigo PG, Girgis KR, Pfuetez BL, Critchlow ME, Fisher J, Hussain I. Efficacy of anti-IgE therapy in patients with atopic dermatitis. *J Am Acad Dermatol* 2006;55:168–70.
93. Krathen RA, Hsu S. Failure of omalizumab for treatment of severe adult atopic dermatitis. *J Am Acad Dermatol* 2005;53:338–40.
94. Lane JE, Cheyney JM, Lane TN, Kent DE, Cohen DJ. Treatment of recalcitrant atopic dermatitis with omalizumab. *J Am Acad Dermatol* 2006;54:68–72.
95. Lacombe Barrios J, Bégin P, Paradis L, Hatami A, Paradis J, Des Roches A. Anti-IgE therapy and severe atopic dermatitis: a pediatric perspective. *J Am Acad Dermatol* 2013;69:832–4.
96. Hotze M, Baurecht H, Rodríguez E, Chapman-Rothe N, Ollert M, Fölster-Holst R, et al. Increased efficacy of omalizumab in atopic dermatitis patients with wild-type flaggrin status and higher serum levels of phosphatidylcholines. *Allergy* 2014;69:132–5.

# Urticaria and Angioedema

BRUCE L. ZURAW

## KEY POINTS

- The distinction between acute and chronic urticaria/angioedema has important diagnostic and therapeutic implications. Recurrent angioedema without urticaria suggests the possibility of hereditary angioedema.
- The most common type of swelling in children is acute urticaria/angioedema. The cause of acute urticaria can often be determined and is most likely to involve IgE-mediated reactions, viral infections or bites and stings.
- Chronic urticaria/angioedema is typically idiopathic; however, physical stimuli often contribute to the symptoms. Extensive diagnostic evaluation of chronic urticaria is usually not warranted.
- First-line treatment of urticaria/angioedema is non-sedating antihistamines with dosing up to four times the usual dose if necessary.
- Omalizumab or cyclosporine may be considered for patients with chronic urticaria who do not respond to high-dose antihistamines and do not have an underlying urticarial vasculitis.

Urticaria (hives or wheals) typically presents as a pruritic generalized eruption with erythematous circumscribed borders and pale, slightly elevated centers (Figure 52-1A). Angioedema is characterized by an asymmetric nondependent swelling that is generally not pruritic (Figure 52-1B). The pathophysiology of urticaria and angioedema is similar and is due to increased vascular permeability. However, the underlying mechanisms can be very distinct: mast cells are usually implicated in urticaria but bradykinin may be the cause in angioedema. Affected patients may manifest symptoms that range from transient and mildly annoying hives to severe and potentially fatal angioedema. Quality of life has been reported to be moderately to severely impaired in patients with chronic urticaria,<sup>1-3</sup> and children with chronic urticaria exhibit significantly greater psychiatric morbidity than controls.<sup>4</sup> An efficient and cost-effective approach to the management of urticaria and angioedema depends on a careful assessment of the characteristics and likely cause of the swelling. This chapter provides a framework to differentiate the various types of urticaria and angioedema, then outlines a directed evaluation and treatment plan based on the etiology (Box 52-1).

## Epidemiology/Etiology

### EPIDEMIOLOGY

Urticaria/angioedema is conventionally classified as either *acute* or *chronic*, the latter being defined as the continuous or frequent

occurrence of lesions for longer than 6 weeks.<sup>5</sup> While arbitrary, this distinction has significant implications regarding the cause, course and treatment of the swelling. Most urticaria/angioedema is acute, particularly in children. Acute urticaria/angioedema can occur during anaphylaxis, and this possibility needs to be considered when urticaria or angioedema is associated with respiratory, gastrointestinal, cardiovascular or nervous system involvement. Approximately 50% of affected patients experience both urticaria and angioedema, 40% only urticaria, and 10% only angioedema.<sup>6</sup> Surveys have indicated that 15% to 23% of the population experience urticaria at least once during their lifetime,<sup>7</sup> while the prevalence of chronic urticaria is estimated to be 0.5% to 5%, with females over-represented.<sup>8,9</sup> Atopic individuals are at increased risk for acute urticaria/angioedema and some forms of physical urticaria; however, most patients with chronic urticaria/angioedema are not atopic.

The prevalence of hereditary angioedema (HAE) due to C1 inhibitor (C1INH) deficiency (HAE-C1INH) is approximately 1:50,000. The prevalence of HAE with normal C1INH (HAE-nC1INH) is unknown but likely less than HAE-C1INH. Acquired C1INH deficiency is only seen in adults and has an estimated prevalence of 1:500,000. Bradykinin-mediated angioedema can also be associated with use of angiotensin-converting enzyme inhibitors and possibly with recurrent idiopathic angioedema.

### ETIOLOGY

Most urticaria/angioedema is caused by mast cell degranulation with released mediators causing activation of sensory nerves, vasodilation, plasma extravasation, up-regulation of endothelial cell adhesion molecules and recruitment of inflammatory cells.<sup>10-12</sup> Basophils may also play an important role.<sup>13</sup> The causes of mast cell degranulation in urticaria/angioedema are variable. IgE-mediated mast cell degranulation is responsible for many cases of acute urticaria/angioedema in children, most commonly from drugs and foods. Many acute and most chronic urticaria/angioedema cases involve mast cell activation due to nonimmunologic or immune processes not involving IgE, such as direct mast cell degranulators, viral infections, anaphylatoxins, various peptides/proteins and several types of physical stimuli. Viral infections are the most common cause of acute urticaria in children.<sup>14,15</sup>

The underlying cause of mast cell degranulation in chronic urticaria/angioedema usually cannot be determined. Lesions demonstrate a nonnecrotizing mononuclear cell infiltrate around small venules, with increased numbers of basophils, eosinophils and T helper cells.<sup>10,16</sup> Filaggrin is overexpressed in urticarial lesions, the level correlating with urticaria severity.<sup>17</sup> Activation of thrombin with subsequent generation of C5a has also been suggested as a potential underlying mechanism in chronic urticaria.<sup>18</sup> Some children with celiac disease and severe



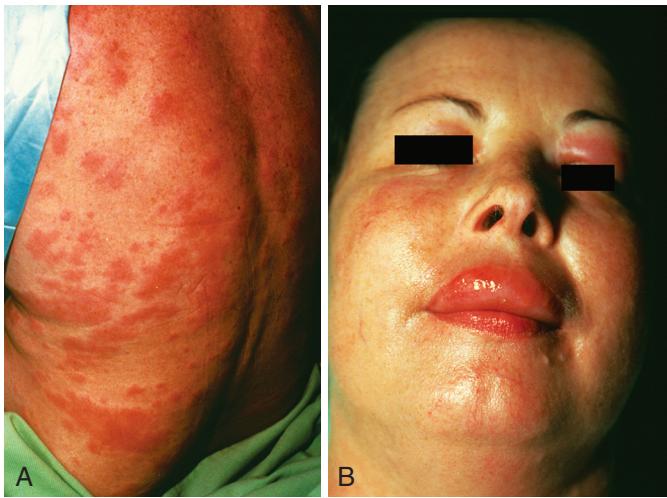

**Figure 52-1** Typical examples of swelling. (A) Diffuse urticaria with areas of confluence. (B) Angioedema of the upper lip and face.

### BOX 52-1 KEY CONCEPTS

#### Urticaria and Angioedema

- The distinction between acute and chronic urticaria/angioedema has important diagnostic and therapeutic implications.
- The most common type of swelling in children is acute urticaria/angioedema.
- The cause of acute urticaria can usually be determined and is most likely to involve IgE-mediated reactions, viral infections or bites and stings.
- The cause of chronic urticaria/angioedema is typically idiopathic; however, physical stimuli often contribute to the symptoms.
- Chronic urticaria/angioedema must be distinguished from urticarial vasculitis.
- Recurrent angioedema without urticaria suggests the possibility of hereditary angioedema.
- Most cases of chronic urticaria/angioedema resolve within 3 to 4 years.

chronic urticaria showed improvement of the urticaria following institution of a gluten-free diet.<sup>19</sup> At least 40% of patients with chronic urticaria have circulating autoantibodies with specificity for IgE or the high-affinity FcεR.<sup>20–22</sup> Skin testing with autologous serum or plasma may detect these antibodies.<sup>23</sup> Approximately 30% of children with chronic urticaria have positive autologous serum skin tests.<sup>24,25</sup> The functional and prognostic significance of these autoantibodies remains unclear.

An increased prevalence of thyroid antimicrosomal and antithyroglobulin antibodies has been described in urticaria/angioedema, with about half of these patients having goiters or abnormal thyroid function;<sup>26–29</sup> however, no causal relationship has been demonstrated.<sup>30</sup> Conversely, an increased cumulative prevalence of urticaria/angioedema has been found in thyroid disease patients with antimicrosomal and antithyroglobulin antibodies (primarily Hashimoto's thyroiditis) but not in patients with other types of thyroid disease.<sup>31</sup> Activation of complement by the complement controller domain of thyroperoxidase has been suggested to be an important contributor to development of urticaria/angioedema in patients with

thyroid autoimmunity.<sup>32</sup> An association between urticaria and a variety of autoimmune diseases has also been described, although the nature of the relationship remains uncertain.<sup>33,34</sup>

Severe urticaria/angioedema associated with marked weight gain, pronounced leukocytosis and striking eosinophilia (Gleich syndrome) has been shown to involve increased serum levels of cytokines (including IL-5) during attacks.<sup>35,36</sup> Other cases of urticaria/angioedema have been reported in association with parathyroid disease, polycythemia vera, hemolytic uremic syndrome, Schnitzler syndrome (chronic urticaria, monoclonal IgM, arthralgia, fever and adenopathy) and pregnancy.<sup>37</sup> Cyclical urticaria occurring prior to menses may be an autoimmune progesterone-induced dermatitis.<sup>38</sup> Genetic causes of swelling include HAE, Muckle-Wells syndrome, vibratory angioedema, familial cold autoinflammatory syndrome, familial localized heat urticaria of delayed type, erythropoietic protoporphyria with solar urticaria, C3 inactivator deficiency with urticaria, and serum carboxypeptidase N deficiency with angioedema.

HAE-C1INH is an autosomal dominant disease caused by a functional deficiency of the plasma protein C1INH. Two major types of HAE-C1INH have been described: type I HAE comprises 85% of cases and is characterized by low C1INH antigenic and functional levels; type II HAE comprises the other 15% of cases and is characterized by normal C1INH antigenic levels with low C1INH functional activity due to secretion of a dysfunctional protein.<sup>39</sup> Type I and type II HAE are caused by mutations in the C1INH gene (*SERPING1*), resulting in increased plasma kallikrein activity and generation of the vasoactive mediator bradykinin.<sup>39</sup> Familial recurrent angioedema with normal C1INH gene and protein was originally called type III HAE,<sup>40,41</sup> but has now been named HAE-nlC1INH.<sup>42</sup> Initially thought to affect primarily women exposed to increased estrogen levels, it has become clear that both men and women are affected, with a variable effect of estrogens.<sup>42</sup> Several coagulation factor XII gene mutations have been found in a minority of HAE-nlC1INH kindreds;<sup>43</sup> however, the underlying cause of the disease remains unclear. C1INH deficiency may also be acquired; however, this occurs primarily in older adults and has not been reported in children.

Familial cold autoinflammatory syndrome and Muckle-Wells syndrome have been shown to be associated with mutations in a gene that encodes cryopyrin.<sup>44</sup> The family of autoinflammatory urticarial syndromes is referred to as cryopyrinopathies.<sup>45</sup> Neonatal-onset multisystem inflammatory disease (NOMID) is a particularly severe cryopyrinopathy. The IL-1 receptor antagonist anakinra has been used successfully to prevent attacks.<sup>46,47</sup> A hereditary cold urticaria syndrome due to genomic deletions of *PLCG2* has been shown to lead to a gain of phospholipase *Cy2* function associated with antibody deficiency, susceptibility to infection, and autoimmunity.<sup>48,49</sup>

## Differential Diagnosis

Recognition of urticaria and angioedema on examination is generally straightforward. The single most important step in the differential diagnosis is to visualize the lesions during swelling. Individual urticarial lesions seldom last for more than a few hours (up to 24 hours), which distinguishes urticaria from almost all other skin diseases. In addition, urticarial lesions blanch with pressure and new hives frequently develop as the older ones fade. If the lesions do not itch, the diagnosis should be reconsidered. Angioedema is not dependent and is typically

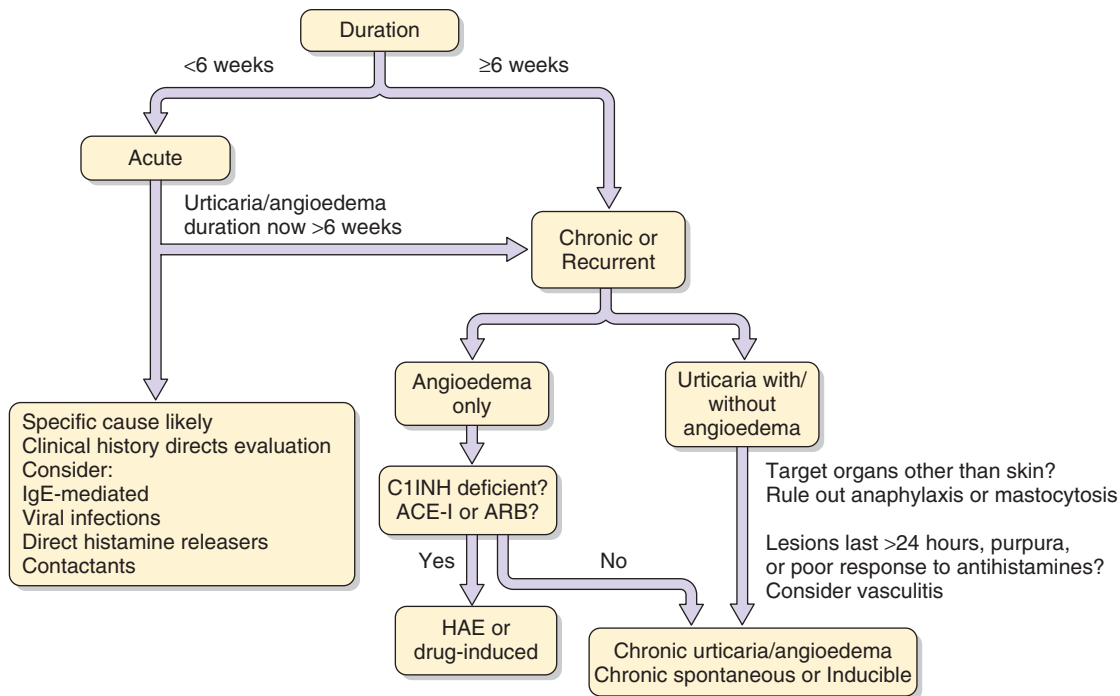

**Figure 52-2** Diagnostic algorithm for urticaria/angioedema. ACE-I – Angiotensin-converting enzyme inhibitor, ARB – angiotensin II receptor blocker, HAE – hereditary angioedema.

not symmetrical. **Figure 52-2** presents an algorithm for the approach to the differential diagnosis.

### ACUTE URTICARIA/ANGIOEDEMA

Acute urticaria/angioedema by definition lasts less than 6 weeks and is most commonly caused by exposure to allergens, toxins or sensitizers, or infections. A cause for acute urticaria/angioedema can frequently be determined. Most cases in children will be secondary to IgE-mediated reactions or viral infections.<sup>14,15</sup> Penicillin and other antibiotics frequently cause urticaria/angioedema. The most common foods associated with IgE-mediated urticaria/angioedema vary with the age of the patient. In younger children, egg, milk, soy, peanut and wheat are the most common allergens, whereas fish, seafood, nuts and peanuts are common offenders in older children.<sup>50</sup> Acute urticaria can also be triggered by ingestion of fish containing high levels of bioactive amines in the absence of specific IgE (scombroid poisoning).<sup>51</sup> Urticaria and angioedema are the most common manifestations of anaphylactic reactions to insect stings and bites. Immunologic reactions to the saliva of bedbugs, fleas or mites can cause papular urticaria, especially on the legs of children. Recently, acute urticaria/angioedema occurring 3 to 6 hours following the ingestion of beef, pork, lamb or venison has been described in patients with IgE against galactose- $\alpha$ -1,3-galactose.<sup>52</sup> Urticaria multiforme (or acute annular urticarial hypersensitivity) is distinguished by transient annular urticarial lesions, often accompanied by angioedema, that respond to antihistamines.<sup>53</sup>

Urticaria/angioedema can also result from exposure to direct mast cell degranulators (such as strawberries, narcotic drugs, polymyxin antibiotics, D-tubocurarine or dextran volume expanders), penetrating substances (such as nettles, Portuguese man-of-war, other forms of sea life, moth and butterfly scales,

tarantula hairs or caterpillar foot processes), or substances that can produce urticaria on contact with intact skin (such as latex, industrial chemicals, benzoic acid, sorbic acid and numerous other agents).<sup>54</sup> Aspirin and other nonsteroidal antiinflammatory drugs (NSAIDs) can provoke acute urticaria/angioedema in children and adults.<sup>55,56</sup>

### CHRONIC URTICARIA/ANGIOEDEMA

This is a diagnosis of exclusion, based on history, examination and carefully selected testing. No clear relationship has been found between chronic urticaria and food allergy, ingestion of food additives or focal infections.<sup>57,58</sup> Parasitic infestations may be suggested by finding substantial eosinophilia, elevated IgE level, abdominal symptoms or a history of recent foreign travel. *Helicobacter pylori* infection has also been suggested as having a link to chronic urticaria.<sup>59-61</sup>

Chronic urticaria is further subdivided into chronic spontaneous urticaria (CSU, previously referred to as chronic idiopathic urticaria) or inducible urticaria (previously known as physical urticaria) based on whether there is a precipitating stimulus.<sup>62</sup> CSU has no identifiable cause and is the most common form of chronic urticaria/angioedema. Patients with CSU may have autoimmune features (see above). Inducible urticaria involves mast cell degranulation precipitated by discrete physical stimuli (**Table 52-1**). Inducible urticaria is often but not always encountered in the setting of co-existing CSU. The percentage of children in whom chronic urticaria also has a physical component ranges from 1% to >10%.<sup>63</sup> Patients may swell in response to one or several physical stimuli, including mechanical pressure or stroking, heat or cold, sunlight or water. Specific physical challenges can be performed to confirm inducible urticaria/angioedema. Dermographism may occur in up to 2% to 5% of the general population (**Figure 52-3A**), and can

**TABLE 52-1** Major Physical Urticaria Syndromes

Type	Provoking Stimuli	Diagnostic Test	Comment
<b>Mechanically Provoked</b>			
Dermographism (urticaria factitia)	Rubbing or scratching of skin causes linear wheals	Stroking the skin (especially the back) elicits a linear wheal	Primary (idiopathic or allergic) or secondary (urticaria pigmentosa or transient following virus or drug reaction)
Delayed dermographism	Same	Same	Rare
Delayed-pressure urticaria	At least 2 hr after pressure is applied to the skin, deep, painful swelling develops, especially involving the palms, soles and buttocks	Attach two sandbags or jugs of fluid (5–15 lb) to either end of a strap and apply over the shoulder or thigh for 10 to 15 min. A positive test exhibits linear wheals or swelling after several hours	Can be disabling and may be associated with constitutional symptoms such as malaise, fever, arthralgia, headache and leukocytosis
Immediate-pressure urticaria	Hives develop within 1 to 2 min of pressure	Several minutes of pressure elicit hives	Rare; seen in conjunction with hypereosinophilic syndrome
<b>Thermally Provoked</b>			
Acquired cold urticaria	Change in skin temperature rapidly provokes urticaria	Place ice cube on extremity for 3 to 5 min, then observe for pruritic welt and surrounding erythema as the skin rewarms over subsequent 5 to 15 min	Relatively common, may occur transiently with exposure to drugs or with infections; other rare cases may be associated with cryoproteins or may be transferable by serum
Familial cold autoinflammatory syndrome	Intermittent episodes of rash, arthralgia, fever and conjunctivitis occur after generalized exposure to cold	Symptoms occur 2 to 4 hr after exposure to cold blowing air	Autosomal dominant inflammatory disorder previously called familial cold 'urticaria'; results from mutation of <i>CIAS1</i> gene, coding for cryopyrin
Cholinergic urticaria	Heat, exertion or emotional upsets cause small punctate wheals with prominent erythematous flare. May be related more to sweating than to heat per se	Methacholine cutaneous challenge is sometimes helpful; better to reproduce the lesions by exercising in a warm environment or while wearing a wetsuit or plastic occlusive suit	Differs from exercise-induced anaphylaxis in that it features smaller wheals and is induced by heat as well as by exercise but does not generally cause patients to collapse. Relatively common in patients with chronic urticaria; can be passively transferred by plasma in some patients
Localized heat urticaria	Urtication occurs at sites of contact with a warm stimulus	Hold a test tube containing warm water against the skin for 5 min	Rare
<b>Miscellaneous Provoked</b>			
Solar urticaria	Urticaria develops in areas of skin exposed to sunlight	Controlled exposure to light; can be divided depending on the wavelength of light eliciting the lesions	Types include genetic abnormality in protoporphyrin IX metabolism as well as types that can be passively transferred by IgE in serum
Aquagenic urticaria	Tiny perifollicular urticarial lesions develop after contact with water of any temperature	Apply towel soaked in 37°C water to the skin for 30 min	Rare; systemic symptoms can occur; females affected more than males; familial form has been described

account for the majority of hives in some patients.<sup>7</sup> Delayed pressure urticaria is more angioedematous than urticarial and causes significant morbidity.<sup>2</sup> Primary and secondary acquired forms of cold urticaria have been described.<sup>64</sup> Primary acquired cold urticaria is often seen in children and is frequently associated with asthma, allergic rhinitis and progression to frank anaphylaxis.<sup>65</sup> Patients with acquired cold urticaria have drowned when exposed to cold water, and must be warned to avoid cold water and never to swim alone. Cold urticaria should be distinguished from familial cold autoinflammatory syndrome, which is marked by cold-induced erythematous rash, fever, arthralgias, leukocytosis and conjunctivitis.<sup>44</sup> Cholinergic urticaria (Figure 52-3B) is relatively common in children, may be confused with exercise-induced anaphylaxis, and can be

associated with angioedema, wheezing or even syncope.<sup>66</sup> Persistent cholinergic erythema, a variant of cholinergic urticaria, can be mistaken for a drug eruption or cutaneous mastocytosis.<sup>67</sup> Many patients have combinations of different physical urticarias, such as cold and cholinergic urticaria, cold and localized heat urticaria, or dermographism with cold urticaria.

Idiopathic anaphylaxis often includes a prominent component of urticaria or angioedema and can be difficult to distinguish from severe urticaria/angioedema.<sup>68</sup> The angioedema of idiopathic anaphylaxis can also resemble HAE; however, a positive family history as well as complement abnormalities will clearly identify HAE-C1INH.

Urticarial vasculitis must be distinguished from chronic idiopathic urticaria/angioedema. When flagrant, urticarial





**Figure 52-3** Examples of physical urticaria. (A) Dermographism. (From Weston WL, Morelli JG, Lane A, editors. *Color textbook of pediatric dermatology*. 3rd ed. St Louis: Mosby; 2002.) (B) Cholinergic urticaria. (From Fireman P, Slavin R, editors. *Atlas of allergies*. 2nd ed. London: Mosby-Wolfe; 1996.)

vasculitis is characterized by palpable purpura and bruising or discoloration that persists after the hive disappears. Persistence of individual urticarial lesions for more than 24 hours or a poor response to antihistamine therapy may suggest the possibility of urticarial vasculitis, which ranges from relatively benign cutaneous hypersensitivity vasculitis to the hypocomplementemic urticarial vasculitis syndrome.<sup>69,70</sup> In children, most cases of cutaneous vasculitis represent Henoch-Schönlein purpura or hypersensitivity vasculitis.<sup>71</sup> The hypocomplementemic urticarial vasculitis syndrome is rarely seen in children.<sup>72</sup>

## ANGIOEDEMA

Angioedema is usually associated with urticaria that is nondependent, asymmetric and nonpruritic. When it occurs with urticaria, the diagnosis and treatment of angioedema mirrors the parameters described for urticaria. Recurrent angioedema without urticaria (including recurrent unexplained abdominal pain) should suggest a possible diagnosis of HAE. Accurate diagnosis of HAE is essential to avoid morbidity and mortality;<sup>73</sup> however, delays in HAE diagnosis are the rule rather than the exception. Repeated surveys have shown a 10- to 20-year interval between onset of symptoms and establishment of the correct diagnosis.<sup>74</sup> Half of all HAE patients begin swelling during the first decade of life, with almost all patients manifesting symptoms by age 18.<sup>75</sup>

Angioedema may also occur during the treatment of hypertension with angiotensin-converting enzyme (ACE) inhibitors

or, less commonly, with angiotensin II receptor blockers.<sup>76</sup> ACE is a peptidase that degrades bradykinin (among other peptides), and the mechanism of ACE inhibitor-associated angioedema is suspected to be due to diminished catabolism of bradykinin.<sup>77</sup> There are also several forms of facial edema that can be confused with angioedema, including the granulomatous cheilitis accompanying Crohn's disease and the Melkersson-Rosenthal syndrome (a rare syndrome of recurrent orofacial swelling, relapsing facial paralysis and fissured tongue).

## Evaluation and Management

### HISTORY

A discerning history is the most important diagnostic procedure in the evaluation of urticaria/angioedema. One should determine whether the urticaria/angioedema is acute or chronic, the duration of the individual lesions, the presence of pruritus (a defining symptom for urticaria), *when* lesions occur, *where* the patient is when lesions occur, *what* has the patient suspected, and the response to prior treatment. Specific inquiry should be made about drugs (including over-the-counter products), foreign sera, foods, food additives, herbal or homeopathic treatments, psychologic factors, inhalants, bites and stings, direct contact of skin with various agents, connective tissue diseases and exposure to physical agents. Associated respiratory, gastrointestinal or musculoskeletal symptoms should be inquired about.

In many patients, the disease is aggravated by vasodilating stimuli such as heat, exercise, emotional stress, alcoholic drinks, fever and hyperthyroidism. Premenstrual exacerbations also are common. Aspirin and other cyclooxygenase (COX)-1 inhibiting NSAIDs can cause acute urticaria or lead to exacerbations in up to 30% of patients. A retrospective review of 1,007 charts of atopic children revealed that 41 (4.07%) had experienced NSAID-induced facial angioedema.<sup>78</sup> Intermittent use of NSAIDs was associated with a higher rate of angioedema than chronic regular use.<sup>79</sup> COX-2 inhibitors and acetaminophen do not typically trigger urticaria or angioedema.<sup>55,80</sup>

Angioedema attacks in HAE-C1INH have distinct manifestations, including: prolonged duration (typically 72 or more hours); frequently triggered by minor trauma or stress; often preceded by a prodromal syndrome; displaying periodicity with attacks of angioedema interspersed by periods of remission (daily episodes suggest an alternate diagnosis); swelling most commonly affecting the extremities, face, gastrointestinal tract or upper airway; and a history of lack of response to prior treatment with antihistamines, corticosteroids or epinephrine.<sup>74</sup> Virtually all HAE-C1INH patients experience extremity and gastrointestinal attacks during their lifetime. Abdominal attacks can be severe, and may resemble a surgical abdomen. Recurrent school absences because of abdominal pain may be a presenting symptom. It is not unusual to obtain a history of a normal exploratory laparotomy for presumed appendicitis. Laryngeal attacks are considerably less common, although over 50% of HAE-C1INH patients will experience a laryngeal attack at some point in their life. Angioedema of the larynx in HAE-C1INH can result in closure of the airway and asphyxiation. In the past, over 30% of HAE-C1INH patients died from airway attacks.<sup>74</sup> A positive family history of angioedema can usually be elicited although up to 25% of HAE-C1INH patients have *de novo* *SERPING1* mutations.<sup>81</sup>



HAE-nlC1INH is also characterized by recurrent prolonged attacks of angioedema that can cause asphyxiation.<sup>40,41,82</sup> Attack frequency varies considerably between affected individuals, from carriers who are asymptomatic to patients with multiple attacks per year. There is a striking female preponderance of patients, and affected women tend to have more severe symptoms than affected men.<sup>83,84</sup> Like HAE-C1INH, the inheritance pattern of HAE-nlC1INH is autosomal dominant; however, the penetrance is often much lower with evidence of obligate asymptomatic carriers, particularly men. HAE-nlC1INH patients appear to manifest symptoms at a somewhat older age than HAE-C1INH patients.<sup>85</sup> They are also less likely to suffer abdominal attacks.

## PHYSICAL EXAMINATION

Urticarial lesions typically are generalized and may involve any part of the body. Individual lesions often coalesce into large lesions. Angioedema is usually asymmetric and typically involves loose connective tissue such as the face or mucous membranes such as the lips or tongue. Occasionally, the appearance of the lesions gives a clue as to the type of urticaria being encountered: linear wheals suggest dermatographism; small wheals surrounded by large areas of erythema suggest cholinergic urticaria; wheals limited to exposed areas suggest solar or cold urticaria; and wheals mainly on the lower extremities suggest papular urticaria or urticarial vasculitis.

## DIAGNOSTIC PROCEDURES

The laboratory evaluation of patients with urticaria or angioedema must be tailored to the clinical situation. In most cases no specific etiology can be established, and the diagnostic approach should therefore be carefully selected and cost effective. If the history or examination provides clues to the cause of the urticaria/angioedema, the evaluation should be pursued using the appropriate tests (e.g. skin testing to confirm IgE-mediated food or drug allergy). In the absence of a specific likely cause, the laboratory evaluation should be minimal.<sup>37,62</sup> **Box 52-2** summarizes a limited laboratory evaluation that could be performed in patients with chronic urticaria/angioedema. Because the cause of chronic urticaria or angioedema is not related to extrinsic allergen exposure in the vast majority of cases, routine skin testing is not cost effective.<sup>37</sup> Patients with a history suggestive of physical urticaria may be challenged to confirm the diagnosis (see **Table 52-1**).<sup>37</sup>

Patients with recurrent angioedema without urticaria should be evaluated for HAE with complement testing, which can readily establish the diagnosis of type I or type II HAE (**Table 52-2**). HAE-nlC1INH patients have a normal C4 as well as normal C1INH antigenic and functional levels. Consensus

criteria for making a diagnosis of HAE-nlC1INH have recently been published.<sup>42</sup> A minority of HAE-nlC1INH patients may have a mutation in the *F12* gene, and testing for these mutations is warranted in suspected cases.

## Treatment

Reassurance is an important aspect of therapy for urticaria/angioedema. Skin lesions are often more frightening in appearance than the generally favorable prognosis warrants and are self-limited. Most urticaria/angioedema spontaneously remits without any irreversible damage. Patients should, however, be made aware of the need for an emergency room visit if laryngeal edema occurs. If the patient has experienced laryngeal edema, many physicians would prescribe and instruct the patient in the use of self-injectable epinephrine. However, one should avoid generating undue anxiety about laryngeal edema because the only known fatalities from this cause have been in patients with HAE, angiotensin-converting enzyme inhibitor-associated angioedema or anaphylactic reactions.

Guidelines for treating patients with urticaria/angioedema are summarized in **Box 52-3**. Obviously the preferred treatment is avoidance of causative agents when these can be identified. An explanation of the disease process and its triggers should

### BOX 52-2 SUGGESTED TESTING FOR CHRONIC URTICARIA/ANGIOEDEMA OF UNKNOWN ETIOLOGY

#### BASIC TESTS

- Routine screening:  
 Complete blood count (CBC) with differential  
 Erythrocyte sedimentation rate (ESR) or C-reactive protein (CRP)
- Optional tests based on history and physical:  
 Liver function tests  
 Antimicrosomal antibodies, antithyroglobulin antibodies  
 Anti-FcεR or anti-IgE antibodies or autologous skin testing  
 Stool for ova and parasites  
 Physical challenges  
 C4, C1INH antigen, C1INH function

#### DISCRETIONARY TESTS BASED ON EVALUATION

- If vasculitis is suspected:  
 Antinuclear antibody  
 Skin biopsy  
 CH<sub>50</sub>  
 Rheumatoid factor  
 Cryoglobulins
- If liver function tests abnormal:  
 Serology for viral hepatitis
- If HAE-nlC1INH is suspected  
 F12 mutation

**TABLE 52-2** Complement Evaluation of Patients with Recurrent Angioedema

Assay	Idiopathic Angioedema	Type I HAE	Type II HAE	HAE-nlC1INH	Acquired C1INH Deficiency	Vasculitis
C4	nl	Low	Low	nl	Low	Low or nl
C1INH level	nl	Low	nl	nl	Low	nl
C1INH function	nl	Low	Low	nl	Low	nl
C1q	nl	nl	nl	nl	Low	Low or nl

HAE – Hereditary angioedema, HAE-nlC1INH – HAE with normal C1INH, C1INH – C1 inhibitor, nl – normal.

**BOX 52-3 THERAPEUTIC PRINCIPLES****Treatment of Urticaria/Angioedema**

Avoidance of known provoking stimuli can greatly improve treatment outcomes.

H<sub>1</sub> antihistamines are the mainstay of treatment, and second-generation H<sub>1</sub> antihistamines are preferred because they have fewer side-effects.

Difficult cases may require treatment with various combinations of second-generation H<sub>1</sub> antihistamines, first-generation H<sub>1</sub> antihistamines, H<sub>2</sub> antihistamines and leukotriene receptor antagonists.

Omalizumab and cyclosporine are often effective for antihistamine-resistant urticaria.

Delayed-pressure urticaria does not generally respond well to antihistamines.

Corticosteroids should be avoided whenever possible and in particular for the treatment of chronic urticaria/angioedema without delayed-pressure urticaria.

The angioedema of hereditary angioedema does not respond to antihistamines, corticosteroids or epinephrine; oropharyngeal attacks of hereditary angioedema must be treated as a medical emergency.

also be helpful for patients with physical urticaria such as dermographism, cholinergic urticaria and delayed-pressure urticaria. Common sense avoidance measures should be reviewed with patients afflicted with cold or solar urticaria. Treatment of any discovered underlying disease is imperative, and genetic counseling should be provided to families with hereditary forms of these conditions. In addition, patients should avoid, to the extent feasible, potentiating factors such as alcoholic drinks, heat, exertion and aspirin.

Antihistamines are the mainstay of treatment for acute or chronic urticaria/angioedema (Figure 52-4).<sup>37,62</sup> Continuous use of antihistamines is justified by their actions as inverse agonists on the H<sub>1</sub> receptor, decreasing spontaneous receptor activity.<sup>86</sup> Used at a sufficient dose, they alleviate pruritus and suppress hive formation. Most first-generation H<sub>1</sub> antihistamines are effective in urticaria; however, common side-effects (particularly drowsiness and anticholinergic effects) are a substantial issue and have limited the usefulness of these drugs.<sup>87</sup> In addition, children may experience either sedation or a paradoxical agitation response to first-generation H<sub>1</sub> antihistamines.<sup>88</sup>

Second-generation H<sub>1</sub> antagonists cross the blood-brain barrier poorly, producing much less central drowsiness or agitation, and have much less anticholinergic effect. In general, first-generation antihistamines should be avoided for the treatment of urticaria, particularly in children.<sup>62</sup> Second-generation H<sub>1</sub> antagonists have thus become the preferred drugs for the first-line treatment of urticaria/angioedema, including for infants as young as 6 months.<sup>37,62,89</sup> The most commonly used second-generation H<sub>1</sub> antihistamines in the USA are cetirizine, loratadine, desloratadine and fexofenadine. Each of these has been shown to be well tolerated and effective for the treatment of urticaria/angioedema.<sup>90</sup> The recommended doses for the pediatric population are shown in Table 52-3. Up-dosing of second-generation antihistamines up to 4 times the usual dosage has been shown to be effective for control of urticaria in adults and children.<sup>91</sup>

Because the cutaneous vasculature expresses H<sub>2</sub> as well as the more abundant H<sub>1</sub> receptors, the addition of an H<sub>2</sub> antihistamine may provide significant benefit for patients who are

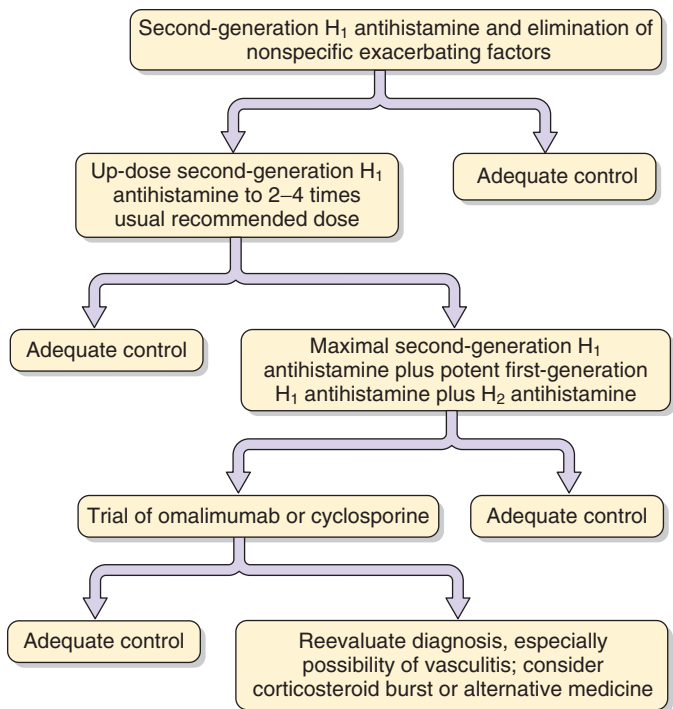

**Figure 52-4** Therapeutic algorithm for chronic urticaria/angioedema.

refractory to H<sub>1</sub> antihistamines alone, although the evidence for their efficacy is weak.<sup>37,62</sup> Leukotriene receptor antagonists have shown some promise in the treatment of urticaria/angioedema, particularly in combination with an antihistamine regimen;<sup>92</sup> however, clear evidence of benefit from randomized, double-blinded studies is lacking.<sup>93</sup> The addition of ephedrine or terbutaline is another option but is generally not effective and is often associated with significant side-effects. While almost all patients will respond to antihistamine therapy, patient variability dictates an empiric approach to achieve optimal results.

Lack of response should raise the possibility of an underlying urticarial vasculitis, particularly when individual hives last for longer than 24 hours. It should be emphasized, however, that the physician must document the continuing hives by direct observation. Patients should be treated with high-dose second-generation H<sub>1</sub> antihistamines for at least one week before they are considered to be ineffective. Furthermore, it is often helpful to counsel the patient and patient's family that the goal of therapy is not to suppress the swelling totally, but rather to minimize the urticaria/angioedema to the point that it is tolerable. Addition of a potent first-generation antihistamine (hydroxyzine or doxepin) titrated to tolerance may help in patients who are not fully responsive to high-dose second-generation antihistamines.<sup>94</sup> Avoidance of dietary 'pseudoallergens' (substances that induce hypersensitivity/intolerance reactions such as food additives, vasoactive substances such as histamine, and some natural substances in fruits, vegetables and spices) has been reported to improve CSU in a minority of patients.<sup>95</sup>

In those patients who require additional therapy, third-line treatments for chronic urticaria are omalizumab or cyclosporine. Omalizumab has been shown in randomized placebo-controlled trials to be highly effective in antihistamine-resistant urticaria in adults and children.<sup>96-100</sup> Cyclosporine has also been

**TABLE 52-3 Dosing of Second-Generation H<sub>1</sub> Antihistamines in the Pediatric Population**

Drug	Supplied As	Usual Dosage	Earliest Approved Age
Cetirizine	Tablets: 5, 10 mg Syrup: 1 mg/mL	6 mo to 1 yr: 2.5 mg/d 1 to 2 yr: 2.5 mg bid 2 to 5 yr: 2.5 mg bid or 5 mg qd 6 to 11 yr: 5–10 mg/d ≥12 yr: 10 mg/d	6 mo
Loratadine	Tablets/Reditabs: 10 mg Syrup: 1 mg/mL	2 to 6 yr: 5 mg/d ≥6 yr: 10 mg/d	2 yr
Fexofenadine	Tablets: 30, 60, 180 mg Oral suspension: 6 mg/mL	6 mo to 2 yr: 15 mg/d 2 to 11 yr: 30 mg bid ≥12 yrs: 60 mg bid or 180 mg/d	6 mo
Desloratadine	Tablets/Reditabs: 5 mg	6 mo to 1 yr: 1 mg/d 1 to 5 yr: 1.25 mg/d 6 to 12 yr: 2.5 mg/d ≥12 yrs: 5 mg/d	6 mo

shown to be effective for chronic urticaria in randomized placebo-controlled studies.<sup>101,102</sup> The safety of cyclosporine in children is less well established than in adults; however, it has also been shown to be efficacious in children with chronic urticaria.<sup>103,104</sup> Patients treated with cyclosporine need to be carefully monitored with cyclosporine serum concentrations and measures of renal function and blood pressure. A variety of other drugs (including dapsone, colchicine, hydroxychloroquine, methotrexate, sulfasalazine and intravenous gammaglobulin) have been reported to be helpful, although most of the reports are anecdotal.

In cases of severe antihistamine-resistant urticaria, a brief course of corticosteroids could be cautiously considered but the potential side-effects need to be discussed.<sup>105</sup> Parenteral corticosteroids are often effective in controlling severe urticaria/angioedema as well as urticarial vasculitis;<sup>105</sup> however, the potential side-effects from chronic use of corticosteroids mandate that they be used at the lowest possible dose for the shortest period of time.<sup>106,107</sup>

The treatment of HAE is distinct from that of allergic or idiopathic angioedema. Treatment of HAE is best considered as three separate goals: treatment of acute attacks, short-term prophylaxis and long-term prophylaxis.<sup>108</sup> It is crucial to recognize that standard angioedema treatment modalities, such as epinephrine, corticosteroids or antihistamines, do not have a significant impact on the swelling in HAE. Due to the complexity of treatment of HAE, involvement of an expert physician and extensive patient education are recommended.<sup>108</sup>

Acute HAE attacks should be treated with drugs that specifically and effectively target the pathophysiology of the disease (Table 52-4). Published guidelines concur that all HAE patients should have ready access to these drugs, that attacks at all sites are eligible for treatment, and that treatment is most effective when administered early in an attack.<sup>73,108–111</sup> Two different C1INH concentrates have been approved in the USA for treatment of HAE attacks – plasma-derived C1INH (Berinert) and recombinant human C1INH (Ruconest). Both are administered by intravenous injection and have been approved for use in adolescent and adult HAE patients. Home therapy with intravenous C1INH was also shown to be safe and effective in children.<sup>112</sup> Two other drugs that antagonize bradykinin generation or action have been approved for treatment of acute HAE attacks: a plasma kallikrein inhibitor (ecallantide) and a

**TABLE 52-4 Drugs Used for Treatment of Acute HAE Attacks in Children**

Drug Class and Name	Dose	Side-Effects
<b>C1INH Concentrates</b>		
Berinert	20 units/kg, IV	<i>Common:</i> bruising and pain at site of injection <i>Uncommon:</i> thrombosis, allergic reaction
Ruconest	50 units/kg, IV	<i>Common:</i> bruising and pain at site of injection <i>Uncommon:</i> thrombosis, allergic reaction
<b>Plasma Kallikrein Inhibitor</b>		
Ecaltantide	30 mg SC children ≥12	<i>Common:</i> none <i>Uncommon:</i> anaphylaxis
<b>Bradykinin B<sub>2</sub> Receptor Antagonist</b>		
Icatibant	30 mg SC children ≥18	<i>Common:</i> wheal and pain at injection site <i>Uncommon:</i> none

IV – Intravenous, SC – subcutaneous.

bradykinin B<sub>2</sub> receptor antagonist (icatibant). Ecallantide and icatibant have been approved for use in the USA for treatment of acute attacks in HAE patients age 16 and older, and 18 and older, respectively.

Prophylactic treatment of HAE is used to reduce the likelihood of swelling in a patient undergoing a stressor or procedure likely to precipitate an attack (short-term prophylaxis) or to decrease the number and severity of angioedema attacks (long-term prophylaxis). The extent of the local trauma may influence the decision on whether to treat the patient prophylactically. C1INH replacement given for short-term prophylaxis should be administered 1 to 12 hours prior to the stressor. High-dose anabolic androgens used for short-term prophylaxis in adults should be started 7 to 10 days prior to the stressor. It is critically important that effective on-demand treatment also be available whether the patient is given short-term prophylaxis or not.

There is little consensus regarding which patients should receive long-term prophylactic treatment. In general, the decision to start a patient on long-term prophylaxis should be

**TABLE 52-5** Drugs Used for Long-Term Prophylaxis of HAE in Children

Drug Class and Name	Usual Pediatric Dose (Typical Range of Doses)	Side-Effects
<b>Antifibrinolytic Agents</b>		
Epsilon aminocaproic acid	0.05 g/kg bid (0.025 g/kg bid–0.1 g/kg bid)	<i>Common:</i> nausea, vertigo, diarrhea, postural hypotension, fatigue, muscle cramps with increased muscle enzymes <i>Uncommon:</i> thrombosis
Tranexamic acid	20 mg/kg bid (10 mg/kg bid–25 mg/kg tid)	
<b>17<math>\alpha</math>-Alkylated Androgens</b>		
Danazol	50 mg/d (50 mg/wk–200 mg/d)	<i>Common:</i> weight gain, virilization, acne, altered libido, muscle pain/cramps, headache, depression, fatigue, nausea, constipation, menstrual abnormalities, increase in liver enzymes, hypertension, altered lipid profile <i>Uncommon:</i> decreased rate of growth in children, masculinization of female fetus, cholestatic jaundice, peliosis hepatis, hepatocellular adenoma
Stanozolol	0.5–1 mg/day for children <6 yr; up to 2 mg/d for children $\geq$ 6 yr	
Oxandrolone	0.1 mg/kg/d	
<b>C1INH Concentrate</b>		
Cinryze	1,000 units IV 2 $\times$ /wk for adolescents	<i>Common:</i> bruising and pain at injection site <i>Uncommon:</i> thrombosis, allergic reaction

individualized, taking into account attack frequency, attack severity, co-morbid conditions, access to emergent treatment and patient experience and preference. The most commonly used medications for long-term prophylaxis of HAE are anabolic androgens and plasma-derived C1INH concentrate (Cinryze) (Table 52-5). Anabolic androgens, however, are relatively contraindicated in children under the age of 16.<sup>113,114</sup> Antifibrinolytic drugs, epsilon aminocaproic acid or tranexamic acid can also be used for long-term prophylaxis but are typically less effective.

## Conclusions

Urticaria and angioedema are common clinical problems whose manifestations range from trivial and intermittent to life threatening. To minimize spending time and money unnecessarily on complicated work-ups, while simultaneously not overlooking important diagnoses, the clinician must be able to characterize urticaria/angioedema by chronicity, type and, increasingly, pathogenesis. With careful detective work, the cause of acute urticaria/angioedema can often be determined and appropriate interventions can be instituted that should lead to prompt

resolution of the problem. A discrete cause of chronic urticaria, by contrast, is rarely established, forcing the clinician into the role of suppressing symptoms but not curing the problem. Although frequently frustrating for both the patient and the physician, the treatment of chronic urticaria can almost always achieve adequate results until the swelling disorder spontaneously remits. Hereditary angioedema is a rare but important cause of recurrent angioedema, and timely screening for HAE is the key to protecting these patients from potentially severe morbidity and mortality.

## Helpful Websites

- The American Academy of Dermatology ([www.aad.org/](http://www.aad.org/))
- The American Academy of Allergy Asthma & Immunology ([www.aaaai.org](http://www.aaaai.org))
- The Hereditary Angioedema (HAE) Association ([www.hereditaryangioedema.com](http://www.hereditaryangioedema.com))

The complete reference list can be found on the companion Expert Consult website at <http://www.expertconsult.inkling.com>.

## KEY REFERENCES

- Sabroe RA, Greaves MW. Chronic idiopathic urticaria with functional autoantibodies: 12 years on. *Br J Dermatol* 2006;154:813–19.
- Confino-Cohen R, Chodick G, Shalev V, Leshno M, Kimhi O, Goldberg A. Chronic urticaria and autoimmunity: associations found in a large population study. *J Allergy Clin Immunol* 2012;129:1307–13.
- Bernstein JA, Lang DM, Khan DA, Craig T, Dreyfus D, Hsieh F, et al. The diagnosis and management of acute and chronic urticaria: 2014 update. *J Allergy Clin Immunol* 2014; 133:1270–7.
- Zuraw BL, Bork K, Binkley KE, Banerji A, Christiansen SC, Castaldo A, et al. Hereditary angioedema with normal C1 inhibitor function: consensus of an international expert panel. *Allergy Asthma Proc* 2012;33(Suppl. 1): S145–56.
- Zuberbier T, Aberer W, Asero R, Bindslev-Jensen C, Brzoza Z, Canonica GW, et al. The EAACI/GA(2) LEN/EDF/WAO Guideline for the definition, classification, diagnosis, and management of urticaria: the 2013 revision and update. *Allergy* 2014;69:868–87.
- Zuraw BL, Bernstein JA, Lang DM, Craig T, Dreyfus D, Hsieh F, et al. A focused parameter update: hereditary angioedema, acquired C1 inhibitor deficiency, and angiotensin-converting enzyme inhibitor-associated angioedema. *J Allergy Clin Immunol* 2013;131:1491–3 e25.
- Kaplan AP. Therapy of chronic urticaria: a simple, modern approach. *Ann Allergy Asthma Immunol* 2014;112:419–25.
- Maurer M, Rosen K, Hsieh HJ, Saini S, Grattan C, Gimenez-Arnau A, et al. Omalizumab for the treatment of chronic idiopathic or spontaneous urticaria. *N Engl J Med* 2013;368:924–35.
- Zuraw BL, Banerji A, Bernstein JA, Busse PJ, Christiansen SC, Davis-Lorton M, et al. US Hereditary Angioedema Association Medical Advisory Board 2013 recommendations for the management of hereditary angioedema due to C1 inhibitor deficiency. *J Allergy Clin Immunol Pract* 2013;1:458–67.
- Cicardi M, Bork K, Caballero T, Craig T, Li HH, Longhurst H, et al. Evidence-based recommendations for the therapeutic management of angioedema owing to hereditary C1 inhibitor deficiency: consensus report of an International Working Group. *Allergy* 2012;67:147–57.



## REFERENCES

- O'Donnell BF, Lawlor F, Simpson J, Morgan M, Greaves MW. The impact of chronic urticaria on the quality of life. *Br J Dermatol* 1997; 136:197–201.
- Poon E, Seed PT, Greaves MW, Kobza-Black A. The extent and nature of disability in different urticarial conditions. *Br J Dermatol* 1999;140: 667–71.
- Jauregui I, Ortiz de Frutos FJ, Ferrer M, Gimenez-Arnau A, Sastre J, Bartra J, et al. Assessment of severity and quality of life in chronic urticaria. *J Investig Allergol Clin Immunol* 2014;24:80–6.
- Herguner S, Kilic G, Karakoc S, Tamay Z, Tuzun U, Guler N. Levels of depression, anxiety and behavioural problems and frequency of psychiatric disorders in children with chronic idiopathic urticaria. *Br J Dermatol* 2011;164: 1342–7.
- Vonakis BM, Saini SS. New concepts in chronic urticaria. *Curr Opin Immunol* 2008;20: 709–16.
- Champion RH, Roberts S, Carpenter RG, Roger JH. Urticaria and angioedema: a review of 554 patients. *Br J Derm* 1969;81:588–97.
- Mathews KP. Urticaria and angioedema. *J Allergy Clin Immunol* 1983;72:1–14.
- Zuberbier T, Balke M, Worm M, Edenharter G, Maurer M. Epidemiology of urticaria: a representative cross-sectional population survey. *Clin Exp Dermatol* 2010;35:869–73.
- Kasperska-Zajac A, Brzoza Z, Rogala B. Sex hormones and urticaria. *J Dermatol Sci* 2008; 52:79–86.
- Hennino A, Berard F, Guillot I, Saad N, Rozieres A, Nicolas JF. Pathophysiology of urticaria. *Clin Rev Allergy Immunol* 2006;30: 3–11.
- Atkins PC, Zweiman B. The IgE-mediated late-phase skin response – unravelling the enigma. *J Allergy Clin Immunol* 1987;79:12–15.
- Haas N, Hermes B, Henz BM. Adhesion molecules and cellular infiltrate: histology of urticaria. *J Investig Dermatol Symp Proc* 2001;6: 137–8.
- Eckman JA, Hamilton RG, Gober LM, Sterba PM, Saini SS. Basophil phenotypes in chronic idiopathic urticaria in relation to disease activity and autoantibodies. *J Invest Dermatol* 2008;128:1956–63.
- Novembre E, Cianferoni A, Mori F, Barni S, Calogero C, Bernardini R, et al. Urticaria and urticaria related skin condition/disease in children. *Eur Ann Allergy Clin Immunol* 2008;40: 5–13.
- Sackesen C, Sekerel BE, Orhan F, Kocabas CN, Tuncer A, Adalioglu G. The etiology of different forms of urticaria in childhood. *Pediatr Dermatol* 2004;21:102–8.
- Ying S, Kikuchi Y, Meng Q, Kay AB, Kaplan AP. TH1/TH2 cytokines and inflammatory cells in skin biopsy specimens from patients with chronic idiopathic urticaria: comparison with the allergen-induced late-phase cutaneous reaction. *J Allergy Clin Immunol* 2002;109: 694–700.
- Ye YM, Kim BE, Shin YS, Park HS, Leung DY. Increased epidermal flaggrin in chronic idiopathic urticaria is associated with severity of urticaria. *Ann Allergy Asthma Immunol* 2014; 112:533–8.
- Asero R, Tedeschi A, Riboldi P, Griffini S, Bonanni E, Cugno M. Severe chronic urticaria is associated with elevated plasma levels of D-dimer. *Allergy* 2008;63:176–80.
- Caminiti L, Passalacqua G, Magazzu G, Comisi F, Vita D, Barberio G, et al. Chronic urticaria and associated coeliac disease in children: a case-control study. *Pediatr Allergy Immunol* 2005;16:428–32.
- Hide M, Francis DM, Grattan CE, Hakimi J, Kochan JP, Greaves MW. Autoantibodies against the high-affinity IgE receptor as a cause of histamine release in chronic urticaria. *N Engl J Med* 1993;328:1599–604.
- Sabroe RA, Greaves MW. Chronic idiopathic urticaria with functional autoantibodies: 12 years on. *Br J Dermatol* 2006;154:813–19.
- Soundararajan S, Kikuchi Y, Joseph K, Kaplan AP. Functional assessment of pathogenic IgG subclasses in chronic autoimmune urticaria. *J Allergy Clin Immunol* 2005;115:815–21.
- Asero R, Tedeschi A, Riboldi P, Cugno M. Plasma of patients with chronic urticaria shows signs of thrombin generation, and its intradermal injection causes wheal-and-flare reactions much more frequently than autologous serum. *J Allergy Clin Immunol* 2006;117:1113–17.
- Brunetti L, Francavilla R, Miniello VL, Platzer MH, Rizzi D, Lospalluti ML, et al. High prevalence of autoimmune urticaria in children with chronic urticaria. *J Allergy Clin Immunol* 2004;114:922–7.
- Du Toit G, Prescott R, Lawrence P, Johar A, Brown G, Weinberg EG, et al. Autoantibodies to the high-affinity IgE receptor in children with chronic urticaria. *Ann Allergy Asthma Immunol* 2006;96:341–4.
- Leznoff A, Sussman GL. Syndrome of idiopathic chronic urticaria and angioedema with thyroid autoimmunity: a study of 90 patients. *J Allergy Clin Immunol* 1989;84:66–71.
- Rumbyrt JS, Katz JL, Schocket AL. Resolution of chronic urticaria in patients with thyroid autoimmunity. *J Allergy Clin Immunol* 1995; 96:901–5.
- Verneuil L, Leconte C, Ballet JJ, Coffin C, Laroche D, Izard JP, et al. Association between chronic urticaria and thyroid autoimmunity: a prospective study involving 99 patients. *Dermatology* 2004;208:98–103.
- Levy Y, Segal N, Weintrob N, Danon YL. Chronic urticaria: association with thyroid autoimmunity. *Arch Dis Child* 2003;88: 517–19.
- Monge C, Demarco P, Burman KD, Wartofsky L. Autoimmune thyroid disease and chronic urticaria. *Clin Endocrinol (Oxford)* 2007;67: 473–5.
- Lanigan SW, Short P, Moul P. The association of chronic urticaria and thyroid autoimmunity. *Clin Exp Derm* 1987;12:335–8.
- Kirkpatrick CH. A mechanism for urticaria/angioedema in patients with thyroid disease. *J Allergy Clin Immunol* 2012;130:988–90.
- Confino-Cohen R, Chodick G, Shalev V, Leshno M, Kimhi O, Goldberg A. Chronic urticaria and autoimmunity: associations found in a large population study. *J Allergy Clin Immunol* 2012;129:1307–13.
- Stitt JM, Dreskin SC. Urticaria and autoimmunity: where are we now? *Curr Allergy Asthma Rep* 2013;13:555–62.
- Gleich GJ, Schroeter AL, Marcoux JP, Sachs MI, O'Connell EJ, Kohler PF. Episodic angioedema associated with eosinophilia. *N Engl J Med* 1984;310:1621–6.
- Butterfield JH, Leiferman KM, Abrams J, Silver JE, Bower J, Gonchoroff N, et al. Elevated serum levels of interleukin-5 in patients with the syndrome of episodic angioedema and eosinophilia. *Blood* 1992;79:688–92.
- Bernstein JA, Lang DM, Khan DA, Craig T, Dreyfus D, Hsieh F, et al. The diagnosis and management of acute and chronic urticaria: 2014 update. *J Allergy Clin Immunol* 2014;133: 1270–7.
- Kakarla N, Zurawin RK. A case of autoimmune progesterone dermatitis in an adolescent female. *J Pediatr Adolesc Gynecol* 2006;19: 125–9.
- Zuraw BL. Clinical practice. hereditary angioedema. *N Engl J Med* 2008;359:1027–36.
- Binkley KE, Davis A 3rd. Clinical, biochemical, and genetic characterization of a novel estrogen-dependent inherited form of angioedema. *J Allergy Clin Immunol* 2000;106:546–50.
- Bork K, Barnstedt SE, Koch P, Traupe H. Hereditary angioedema with normal C1-inhibitor activity in women. *Lancet* 2000;356: 213–17.
- Zuraw BL, Bork K, Binkley KE, Banerji A, Christiansen SC, Castaldo A, et al. Hereditary angioedema with normal C1 inhibitor function: consensus of an international expert panel. *Allergy Asthma Proc* 2012;33(Suppl. 1): S145–56.
- Dewald G, Bork K. Missense mutations in the coagulation factor XII (hageman factor) gene in hereditary angioedema with normal C1 inhibitor. *Biochem Biophys Res Commun* 2006;343:1286–9.
- Hoffman HM, Mueller JL, Broide DH, Wanderer AA, Kolodner RD. Mutation of a new gene encoding a putative pyrin-like protein causes familial cold autoinflammatory syndrome and Muckle-Wells syndrome. *Nat Genet* 2001;29:301–5.
- Federici S, Gattorno M. A practical approach to the diagnosis of autoinflammatory diseases in childhood. *Best Pract Res Clin Rheumatol* 2014;28:263–76.
- Hoffman HM, Rosengren S, Boyle DL, Cho JY, Nayar J, Mueller JL, et al. Prevention of cold-associated acute inflammation in familial cold autoinflammatory syndrome by interleukin-1 receptor antagonist. *Lancet* 2004;364:1779–85.
- Kone-Paut I, Piram M. Targeting interleukin-1beta in CAPS (cryopyrin-associated periodic) syndromes: what did we learn? *Autoimmun Rev* 2012;12:77–80.
- Gandhi C, Healy C, Wanderer AA, Hoffman HM. Familial atypical cold urticaria: description of a new hereditary disease. *J Allergy Clin Immunol* 2009;124:1245–50.
- Ombrello MJ, Remmers EF, Sun G, Freeman AF, Datta S, Torabi-Parizi P, et al. Cold urticaria, immunodeficiency, and autoimmunity related to PLCG2 deletions. *N Engl J Med* 2012;366:330–8.
- Baxi S, Dinakar C. Urticaria and angioedema. *Immunol Allergy Clin North Am* 2005;25:353–67, vii.
- Chegini S, Metcalfe DD. Contemporary issues in food allergy: seafood toxin-induced disease in the differential diagnosis of allergic reactions. *Allergy Asthma Proc* 2005;26: 183–90.

52. Kennedy JL, Stallings AP, Platts-Mills TA, Oliveira WM, Workman L, James HR, et al. Galactose-alpha-1,3-galactose and delayed anaphylaxis, angioedema, and urticaria in children. *Pediatrics* 2013;131:e1545–52.
53. Shah KN, Honig PJ, Yan AC. 'Urticaria multiforme': a case series and review of acute annular urticarial hypersensitivity syndromes in children. *Pediatrics* 2007;119:e1177–83.
54. Burdick AE, Mathias C. The contact urticaria syndrome. *Derm Clin* 1985;3:71–84.
55. Grattan CE. Aspirin sensitivity and urticaria. *Clin Exp Dermatol* 2003;28:123–7.
56. Diaz Jara M, Perez Montero A, Gracia Bara MT, Cabrerizo S, Zapatero L, Martinez Molero MI. Allergic reactions due to ibuprofen in children. *Pediatr Dermatol* 2001;18:66–7.
57. Simon RA. Additive-induced urticaria: experience with monosodium glutamate (MSG). *J Nutr* 2000;130(Suppl. 4S):1063S–6S.
58. Rorsman H. Basophilic leukopenia in different forms of urticaria. *Acta Allergol* 1962;17:168–84.
59. Greaves MW. Pathophysiology of chronic urticaria. *Int Arch Allergy Immunol* 2002;127:3–9.
60. Sadighha A, Shirali R, Zahed GM. Relationship between *Helicobacter pylori* and chronic urticaria. *J Eur Acad Dermatol Venereol* 2009;23:198–9.
61. Yadav MK, Rishi JP, Nijawan S. Chronic urticaria and *Helicobacter pylori*. *Indian J Med Sci* 2008;62:157–62.
62. Zuberbier T, Aberer W, Asero R, Bindslev-Jensen C, Brzoza Z, Canonica GW, et al. The EAACI/GA(2) LEN/EDF/WAO Guideline for the definition, classification, diagnosis, and management of urticaria: the 2013 revision and update. *Allergy* 2014;69:868–87.
63. Greaves MW. Chronic urticaria in childhood. *Allergy* 2000;55:309–20.
64. Wanderer AA, Grandel KE, Wasserman SI, Farr RS. Clinical characteristics of cold-induced systemic reactions in acquired cold urticaria syndromes: recommendations for prevention of this complication and a proposal for a diagnostic classification of cold urticaria. *J Allergy Clin Immunol* 1986;78 (3 Pt 1):417–23.
65. Alangari AA, Twarog FJ, Shih MC, Schneider LC. Clinical features and anaphylaxis in children with cold urticaria. *Pediatrics* 2004;113:e313–17.
66. Lawrence CM, Jorizzo JL, Kobza-Black A, Coutts A, Greaves MW. Cholinergic urticaria with associated angio-oedema. *Br J Dermatol* 1981;105:543–50.
67. Black AK. Unusual urticarias. *J Dermatol* 2001;28:632–4.
68. Hogan MB, Kelly MA, Wilson NW. Idiopathic anaphylaxis in children. *Ann Allergy Asthma Immunol* 1998;81:140–2.
69. Tosoni C, Lodi-Rizzini F, Cinquini M, Pasolini G, Venturini M, Sinico RA, et al. A reassessment of diagnostic criteria and treatment of idiopathic urticarial vasculitis: a retrospective study of 47 patients. *Clin Exp Dermatol* 2009;34:166–70.
70. Wisniewski JJ. Urticarial vasculitis. *Curr Opin Rheumatol* 2000;12:24–31.
71. Blanco R, Martinez-Taboada VM, Rodriguez-Valverde V, Garcia-Fuentes M. Cutaneous vasculitis in children and adults. Associated diseases and etiologic factors in 303 patients. *Medicine (Baltimore)* 1998;77:403–18.
72. Cadnapaphornchai MA, Saulsbury FT, Norwood VF. Hypocomplementemic urticarial vasculitis: report of a pediatric case. *Pediatr Nephrol* 2000;14:328–31.
73. Zuraw BL, Bernstein JA, Lang DM, Craig T, Dreyfus D, Hsieh F, et al. A focused parameter update: hereditary angioedema, acquired C1 inhibitor deficiency, and angiotensin-converting enzyme inhibitor-associated angioedema. *J Allergy Clin Immunol* 2013;131:1491–3 e25.
74. Frank MM, Gelfand JA, Atkinson JP. Hereditary angioedema: the clinical syndrome and its management. *Ann Intern Med* 1976;84:586–93.
75. Bork K, Meng G, Staubach P, Hardt J. Hereditary angioedema: new findings concerning symptoms, affected organs, and course. *Am J Med* 2006;119:267–74.
76. Warner KK, Visconti JA, Tschappel MM. Angiotensin II receptor blockers in patients with ACE inhibitor-induced angioedema. *Ann Pharmacother* 2000;34:526–8.
77. Byrd JB, Adam A, Brown NJ. Angiotensin-converting enzyme inhibitor-associated angioedema. *Immunol Allergy Clin North Am* 2006;26:725–37.
78. Capriles-Behrens E, Caplin J, Sanchez-Borges M. NSAID facial angioedema in a selected pediatric atopic population. *J Investig Allergol Clin Immunol* 2000;10:277–9.
79. Settignano RA, Constantine HP, Settignano GA. Aspirin intolerance and recurrent urticaria in normal adults and children. *Epidemiology and review. Allergy* 1980;35:149–54.
80. Kelkar PS, Butterfield JH, Teaford HG. Urticaria and angioedema from cyclooxygenase-2 inhibitors. *J Rheumatol* 2001;28:2553–4.
81. Pappalardo E, Cicardi M, Duponchel C, Carugati A, Choquet S, Agostoni A, et al. Frequent de novo mutations and exon deletions in the C1 inhibitor gene of patients with angioedema. *J Allergy Clin Immunol* 2000;106:1147–54.
82. Martin L, Degenne D, Toutain A, Ponard D, Walter H. Hereditary angioedema type III: an additional French pedigree with autosomal dominant transmission. *J Allergy Clin Immunol* 2001;107:747–8.
83. Bork K, Gul D, Dewald G. Hereditary angioedema with normal C1 inhibitor in a family with affected women and men. *Br J Dermatol* 2006;154:542–5.
84. Martin L, Raison-Peyron N, Nothen MM, Cichon S, Drouot C. Hereditary angioedema with normal C1 inhibitor gene in a family with affected women and men is associated with the p.Thr328Lys mutation in the F12 gene. *J Allergy Clin Immunol* 2007;120:975–7.
85. Bork K, Gul D, Hardt J, Dewald G. Hereditary angioedema with normal C1 inhibitor: clinical symptoms and course. *Am J Med* 2007;120:987–92.
86. Monczor F, Fernandez N, Fitzsimons CP, Shayo C, Davio C. Antihistaminergics and inverse agonism: potential therapeutic applications. *Eur J Pharmacol* 2013;715:26–32.
87. Qidwai JC, Watson GS, Weiler JM. Sedation, cognition, and antihistamines. *Curr Allergy Asthma Rep* 2002;2:216–22.
88. Simons FE, Simons KJ. The pharmacology and use of H1-receptor-antagonist drugs. *N Engl J Med* 1994;330:1663–70.
89. Simons FE. Prevention of acute urticaria in young children with atopic dermatitis. *J Allergy Clin Immunol* 2001;107:703–6.
90. Wedi B, Kapp A. Evidence-based therapy of chronic urticaria. *J Dtsch Dermatol Ges* 2007;5:146–57.
91. Staevska M, Popov TA, Kralimarkova T, Lazárova C, Kraeva S, Popova D, et al. The effectiveness of levocetirizine and desloratadine in up to 4 times conventional doses in difficult-to-treat urticaria. *J Allergy Clin Immunol* 2010;125:676–82.
92. Bagenstose SE, Levin L, Bernstein JA. The addition of zafirlukast to cetirizine improves the treatment of chronic urticaria in patients with positive autologous serum skin test results. *J Allergy Clin Immunol* 2004;113:134–40.
93. McBayne TO, Siddall OM. Montelukast treatment of urticaria. *Ann Pharmacother* 2006;40:939–42.
94. Kaplan AP. Therapy of chronic urticaria: a simple, modern approach. *Ann Allergy Asthma Immunol* 2014;112:419–25.
95. Magerl M, Pisarevskaja D, Scheufele R, Zuberbier T, Maurer M. Effects of a pseudoallergen-free diet on chronic spontaneous urticaria: a prospective trial. *Allergy* 2010;65:78–83.
96. Maurer M, Rosen K, Hsieh HJ, Saini S, Grattan C, Gimenez-Arnau A, et al. Omalizumab for the treatment of chronic idiopathic or spontaneous urticaria. *N Engl J Med* 2013;368:924–35.
97. Kaplan A, Ledford D, Ashby M, Canvin J, Zazzali JL, Conner E, et al. Omalizumab in patients with symptomatic chronic idiopathic/spontaneous urticaria despite standard combination therapy. *J Allergy Clin Immunol* 2013;132:101–9.
98. Saini S, Rosen KE, Hsieh HJ, Wong DA, Conner E, Kaplan A, et al. A randomized, placebo-controlled, dose-ranging study of single-dose omalizumab in patients with H1-antihistamine-refractory chronic idiopathic urticaria. *J Allergy Clin Immunol* 2011;128:567–73 e1.
99. Uysal P, Eller E, Mortz CG, Bindslev-Jensen C. An algorithm for treating chronic urticaria with omalizumab: dose interval should be individualized. *J Allergy Clin Immunol* 2014;133:914–15 e2.
100. Ferrer M, Gamboa P, Sanz ML, Goikoetxea MJ, Cabrera-Freitag P, Javaloyes G, et al. Omalizumab is effective in nonautoimmune urticaria. *J Allergy Clin Immunol* 2011;127:1300–2.
101. Grattan CE, O'Donnell BF, Francis DM, Niimi N, Barlow RJ, Seed PT, et al. Randomized double-blind study of cyclosporin in chronic 'idiopathic' urticaria. *Br J Dermatol* 2000;143:365–72.
102. Vena GA, Cassano N, Colombo D, Peruzzi E, Pigatto P. Cyclosporine in chronic idiopathic urticaria: a double-blind, randomized, placebo-controlled trial. *J Am Acad Dermatol* 2006;55:705–9.
103. Doshi DR, Weinberger MM. Experience with cyclosporine in children with chronic idiopathic urticaria. *Pediatr Dermatol* 2009;26:409–13.
104. Neverman L, Weinberger M. Treatment of chronic urticaria in children with antihistamines and cyclosporine. *J Allergy Clin Immunol Pract* 2014;2:434–8.
105. Poon M, Reid C. Do steroids help children with acute urticaria? *Arch Dis Child* 2004;89:85–6.
106. Zuberbier T, Maurer M. Urticaria: current opinions about etiology, diagnosis and therapy. *Acta Derm Venereol* 2007;87:196–205.
107. Grattan CE, Humphreys F. Guidelines for evaluation and management of urticaria in adults and children. *Br J Dermatol* 2007;157:1116–23.

108. Zuraw BL, Banerji A, Bernstein JA, Busse PJ, Christiansen SC, Davis-Lorton M, et al. US Hereditary Angioedema Association Medical Advisory Board 2013 recommendations for the management of hereditary angioedema due to C1 inhibitor deficiency. *J Allergy Clin Immunol Pract* 2013;1:458–67.
109. Cicardi M, Bork K, Caballero T, Craig T, Li HH, Longhurst H, et al. Evidence-based recommendations for the therapeutic management of angioedema owing to hereditary C1 inhibitor deficiency: consensus report of an International Working Group. *Allergy* 2012;67:147–57.
110. Craig T, Pursun EA, Bork K, Bowen T, Boysen H, Farkas H, et al. WAO guideline for the management of hereditary angioedema. *World Allergy Organ J* 2012;5:182–99.
111. Lang DM, Aberer W, Bernstein JA, Chng HH, Grumach AS, Hide M, et al. International consensus on hereditary and acquired angioedema. *Ann Allergy Asthma Immunol* 2012;109:395–402.
112. Kreuz W, Rusicke E, Martinez-Saguer I, Aygoren-Pursun E, Heller C, Klingebiel T. Home therapy with intravenous human C1-inhibitor in children and adolescents with hereditary angioedema. *Transfusion* 2012;52:100–7.
113. Gompels MM, Lock RJ, Abinun M, Bethune CA, Davies G, Grattan C, et al. C1 inhibitor deficiency: consensus document. *Clin Exp Immunol* 2005;139:379–94.
114. Farkas H, Varga L, Szeplaki G, Visy B, Harmat G, Bowen T. Management of hereditary angioedema in pediatric patients. *Pediatrics* 2007;120:e713–22.

# Contact Dermatitis

LUZ FONACIER | MARK BOGUNIEWICZ

## KEY POINTS

- Allergic contact dermatitis (ACD) in children is not uncommon and should be suspected in patients with chronic dermatitis.
- Patch testing is the gold standard for the diagnosis of ACD even in children and should be considered for children with chronic or recurrent eczematous dermatitis including those with atopic dermatitis (AD) who fail to improve with standard treatment. The greatest abuse of patch testing is lack of use.
- Counsel the patient and/or family by identifying and providing a list of the chemicals they are sensitive to and giving synonyms and sources.
- Give patients a list of safe products to use, alternatives and substitutions if possible.
- Patients with a suggestive history or physical findings but negative results on the thin-layer rapid-use epicutaneous test (T.R.U.E. TEST®) should be considered for further evaluation in a patch testing clinic.

Contact dermatitis (CD) is a spectrum of inflammatory skin reactions induced by exposure to external agents. Clinically, CD most commonly manifests as a dermatitis or eczema, but it can present as urticaria, erythroderma, phototoxic or photoallergic reactions, hypopigmentation or hyperpigmentation, and even as an acneiform eruption. The more common type of CD results from tissue damage caused by contact with irritants (irritant CD), whereas contact with allergens causes allergic contact dermatitis (ACD). The former is seen commonly in infants as diaper dermatitis, whereas nickel and poison ivy are more frequent causes of ACD in the pediatric population.<sup>1</sup>

An estimated 85,000 chemicals exist in the world, and approximately 2,800 substances have been identified as contact allergens.<sup>2</sup> The majority of these agents, when applied to the skin, can induce an irritant CD (ICD).<sup>3</sup>

## Epidemiology

It was previously thought that ACD occurs less frequently in children, possibly because of reduced exposure to contact allergens or because the immune system in children may be less susceptible to contact allergens. However, subsequent studies found a sensitization rate of 20% to 24%.<sup>4-6</sup> Two multicenter North American studies describing patch testing in pediatric patients with ACD found that allergen sensitivity rates were not different in children when compared to those of adults in the USA; however, the frequency of the relevant allergen reactions

differed between the two populations.<sup>7,8</sup> Another striking difference was the finding that the frequency of the concomitant diagnosis of atopic dermatitis (AD) was higher (34%) in children with a relevant positive patch test reaction compared to only 11.2% in adults.<sup>8</sup>

ACD is considered rare in the first few months of life but has been reported as early as 1 week of age from a hospital ID bracelet.<sup>9</sup> The prevalence rises with increasing age and by 10 years of age the incidence reaches that seen in adults. Subsequently, variations for some allergens depend on the patterns of exposure. With advancing age, ACD diminishes in severity and in the loss of allergic response in previously sensitized individuals.<sup>10</sup>

In patients suspected of having ACD and referred for patch testing, the positive patch test rates ranged from 14% to 70%. Current relevance was reported at 56% to 93%. In a study by Seidenari et al<sup>11</sup> in Italian children, the highest percentage of positive responses was found in children less than 3 years of age, suggesting a higher sensitization rate in young children. In a study designed to look specifically at infants and young children, Bruckner and colleagues<sup>12</sup> found that 24.5% of asymptomatic children aged 6 months to 5 years were sensitized to one or more contact allergens. Approximately one half of the sensitized children were younger than 18 months. In the adolescent age group, females have significantly higher rates of ACD on the face, likely to be explained by increased exposure to nickel in piercing and to preservative and fragrance in cosmetic products. A USA-based study showed nickel, fragrance, cobalt, thimerosal, Balsam of Peru (BOP), potassium dichromate, neomycin, lanolin, thiuram mix and *p*-phenylenediamine (PPD) to be common allergens in children.<sup>7</sup> Less common, but emerging allergens include cocamidopropyl betaine in 'no tears' shampoos, baby washes and cleansers and disperse dyes in clothing materials. A different study looking at age-related specific allergens showed that, with increasing age, nickel takes the place of mercurials as the principal allergen.<sup>13</sup> With respect to race, in a large study of more than 9,000 individuals, De Leo and colleagues<sup>14</sup> found no difference in the overall response rate to allergens on patch testing between white and black patients.

## Pathogenesis

### IRRITANT CONTACT DERMATITIS

Irritant CD results from contact with agents that abrade or irritate the skin. Irritation is usually a cytotoxic event produced by a wide variety of chemicals, detergents, solvents, alcohol, creams, lotions, ointments and powders and by environmental factors such as wetting, drying, perspiration and temperature extremes. A major finding after exposure to skin irritants is perturbation of the skin barrier with an associated increase in



transepidermal water loss. The mechanism associated with this barrier perturbation may include disorganization of the lipid bilayers in the epidermis.<sup>15</sup> In addition, these changes can stimulate an array of proinflammatory cytokine production in the epidermis.<sup>16</sup>

Although allergens are not implicated in ICD, the skin-associated immune system is clearly involved, and historically few differences were noted when ICD and ACD were compared immunohistopathologically.<sup>17</sup> An important difference between the two forms of CD is that ICD does not require prior sensitization and immunologic memory is not involved in the clinical manifestation. The cellular infiltrate includes CD4<sup>+</sup> T cells with a T helper cell type 1 (Th1)-type profile.<sup>18</sup> A number of studies have identified the epidermal keratinocyte as a key effector cell in the initiation and propagation of contact irritancy. Keratinocytes can release both preformed and newly synthesized cytokines, as well as up-regulate major histocompatibility complex (MHC) class II molecules and induce adhesion molecules in response to irritants.<sup>19</sup> These mediators can cause direct tissue damage, activating Langerhans cells, dermal dendritic cells and endothelial cells, which contribute to further cellular recruitment including neutrophils, lymphocytes and mast cells that also contribute to the inflammatory cascade. The 'final' cellular damage results from inflammatory mediators released by activated, nonsensitized T cells. The inflammatory response is dose and time dependent. Any impairment to the epidermal barrier layer (e.g. fissuring, overhydration) renders the skin more susceptible to an irritant effect. The clinical presentation of ICD is usually restricted to the skin site directly in contact with the offending agent, with little or no extension beyond the site of contact.

## ALLERGIC CONTACT DERMATITIS

Allergic CD is recognized as the prototypic cutaneous cell-mediated hypersensitivity reaction, in which the epidermal Langerhans cell plays a pivotal role.<sup>19</sup> The offending agent, acting as an antigen, initiates the immunologic reaction at the site of contact with the skin. Most environmental allergens are haptens (>500 Da) that bind to carrier proteins to form complete antigens before they can cause sensitization. The thickness and integrity of the skin influence the allergic response. Thus thinner sites such as the eyelids, earlobes and genital skin are most vulnerable, whereas the thicker palms and soles are more resistant. Exposure patterns determine the clinical appearance and course of the dermatitis. An association of filaggrin gene (*FLG*) mutations with contact sensitization to nickel and contact sensitization to nickel combined with intolerance to fashion jewelry, but not with other contact allergens, has been demonstrated.<sup>20</sup> Thus, *FLG* deficiency may represent a risk factor for contact sensitization to allergens.

The immune response of ACD requires completion of both an afferent and an efferent limb. The afferent limb consists of the hapten gaining entrance to the epidermis, activating keratinocytes to release inflammatory cytokines and chemokines including tumor necrosis factor (TNF)- $\alpha$ , GM-CSF, interleukin (IL)-1 $\beta$ , IL-10 and macrophage inflammatory protein (MIP)-2. The latter in turn activate Langerhans cells, other dendritic cells and endothelial cells, leading to an accumulation of even more dendritic cells at the site of antigen contact. In addition, the release of IL-1 $\beta$  by epidermal Langerhans cells promotes their egress from the epidermis. After the uptake of antigen,

Langerhans cells process it while migrating to regional lymph nodes, where they present it to naive T cells. Hapten-specific T cells have been shown to include Th1, Th2, Th17 and T regulatory subsets.<sup>19</sup> An important property of Langerhans cells and dendritic cells is their ability to present exogenous antigens on both MHC class I and class II molecules. This cross-priming leads to the activation of both CD4<sup>+</sup> and CD8<sup>+</sup> hapten-specific T cells.<sup>21</sup>

Although classic delayed-type hypersensitivity reactions are mediated primarily by CD4<sup>+</sup> cells, CD to haptens is mediated primarily by CD8<sup>+</sup> cells with a Th1-type cytokine profile.<sup>22,23</sup>

On subsequent contact of the skin with a hapten, that is, during the elicitation phase of ACD, other antigen-presenting cells (APCs), including macrophages and dermal dendritic cells, may stimulate antigen-specific memory T cells and contribute to the initiation of the local inflammatory response (the dermatitis reaction). The sensitized T cells home in on the hapten-provoked skin site, releasing their inflammatory mediators, which results in epidermal spongiosis ('eczema'). Secondary or subsequent hapten exposure shortens the period of latency from contact to appearance of the rash.

## INNATE IMMUNE RECOGNITION OF HAPTENS

A recent review of early events in ACD described the earliest event in ACD as the formation of hapten-self complexes:<sup>24</sup> pre-haptens oxidize before contact with the skin; pro-haptens such as urushiol are oxidized by the host after contact; complete haptens are directly active. Haptens induce the production of reactive oxygen species, which leads to release of ATP and other damage-associated molecular patterns (DAMPs), as well as to the generation of low-molecular-weight hyaluronic acid. The latter is sensed by neighboring cells via Toll-like receptor 2 (TLR2) and TLR4, resulting in increased expression of pro-IL-1 $\beta$  and pro-IL-18. Activation of the inflammasome by ATP with resultant caspase 1 activity generates active IL-1 $\beta$  and IL-18. Of interest, nickel has been found to directly bind histidine residues in the extracellular domain of TLR4, triggering the activation of this receptor.<sup>25</sup>

## KERATINOCYTE APOPTOSIS AND ECZEMA

Spongiosis is a well-established histologic hallmark of the epidermis in eczema. It is characterized by the diminution and rounding of keratinocytes (condensation), and widening of intercellular spaces resulting in a spongiform appearance of the epidermis that can lead to formation of small intraepidermal vesicles. The function and integrity of the epidermis are dependent on specific cell surface adhesion molecules. Activated T cells infiltrating the skin in eczematous dermatitis induce keratinocyte apoptosis, resulting in spongiosis.<sup>26</sup> Resolution of epidermal spongiosis and cellular infiltrate can be demonstrated when ACD is successfully treated.<sup>27</sup>

## T CELL RECRUITMENT IN ALLERGIC CONTACT DERMATITIS

The recruitment of T cells into the skin is regulated by the expression of the specific skin-homing receptor, cutaneous lymphocyte-associated antigen (CLA), which mediates rolling of T cells over activated endothelial cells expressing E-selectin.<sup>28</sup> In addition, chemokine receptors have been proposed as

important regulators of the tissue targeting of T cells. In this respect, CLA<sup>+</sup> T cells co-express the chemokine receptor CCR4, the ligand for thymus and activation-regulated chemokine TARC (CCL17) and macrophage-derived chemokine (CCL22). CCR4 triggered by TARC exposed on the endothelial cell surface during inflammatory skin disorders is thought to augment integrin-dependent firm adhesion of T cells to endothelial intercellular adhesion molecule (ICAM)-1.<sup>29</sup> T cell migration into peripheral tissues mostly depends on their chemokine receptor profiles. Th1-type cells express high levels of CCR5 and CXCR3, interacting with MIP-1 $\beta$  (CCL4) and interferon gamma (IFN- $\gamma$ )-inducible protein 10 (CXCL10), respectively, whereas Th2-type cells express primarily CCR3, CCR4 and CCR8 and interact with eotaxin (CCL11), TARC and MDC, and I-309 (CCL1).<sup>30</sup>

Epidermal keratinocytes have been shown to be an important source of inflammatory mediators for the initiation and amplification of skin immune responses. Treatment with IFN- $\gamma$  or IFN- $\gamma$  plus TNF- $\alpha$  induces keratinocytes to express ICAM-1 and MHC class II molecules and to release a number of chemokines and cytokines, including IL-1, TNF- $\alpha$  and GM-CSF.<sup>31</sup> IL-17 modulates many of the effects induced by IFN- $\gamma$ . Of note, IL-4, a Th2 cytokine, acts synergistically with the Th1 cytokine IFN- $\gamma$  to enhance keratinocyte ICAM-1 expression and release of the CXCR3 agonistic chemokines, IP-10, monokines induced by IFN- $\gamma$  (Mig; CXCL9), and IFN-inducible T cell  $\alpha$ -chemoattractant (I-TAC; CXCL11), thus augmenting both recruitment and retention of Th1-type cells in lesional skin.<sup>32</sup>

### EFFECTOR T CELLS IN ALLERGIC CONTACT DERMATITIS

Both CD4 and CD8 T cells participate in ACD, with CD8 T cells predominating in effector mechanisms of tissue damage.<sup>33</sup> Budinger and colleagues<sup>34</sup> demonstrated that nickel-responsive peripheral T cells from patients with nickel-induced CD showed a significant overexpression of T cell receptor (TCR)-V $\beta$ 17, and the frequency of TCR-V $\beta$ 17<sup>+</sup> T cells correlated significantly with the *in vitro* reactivity of peripheral blood mononuclear cells to nickel. In addition, the cutaneous infiltrate of nickel-induced patch test reactions consisted primarily of V $\beta$ 17<sup>+</sup> T cells, suggesting that T cells with a restricted TCR-V $\beta$  repertoire predominate in nickel-induced CD and may be crucial in the effector phase of nickel hypersensitivity. Of note, these nickel-specific T cells produced IL-5 but not IFN- $\gamma$ , consistent with a Th2-type cytokine profile. Other studies have shown nickel-specific T cells with a Th1-type profile;<sup>35</sup> in addition, nickel-specific CD4<sup>+</sup> Th1-type cells have been shown to be cytotoxic (along with CD8<sup>+</sup> T cells) against keratinocytes, whereas Th2-type nickel-reactive T cells were not.<sup>36</sup> More recently, IL-17-producing TH17 cells have been shown to play a role in the immunopathology of ACD, including in both innate and adaptive immune responses to nickel.<sup>37</sup>

### REGULATORY T CELLS IN ALLERGIC CONTACT DERMATITIS

Cavani and colleagues<sup>38</sup> described nickel-specific CD4<sup>+</sup> T cells from nickel-allergic subjects that secrete predominantly IL-10, which blocks the maturation of dendritic cells including IL-12 release, thus impairing their capacity to activate specific T

effector lymphocytes. Thus regulatory T cells may limit excessive tissue damage and participate in the resolution of ACD.

## Evaluation and Management

### DIFFERENTIAL DIAGNOSIS

A number of both eczematous and noneczematous dermatoses should be considered in the evaluation of a child with suspected CD. Eczematous dermatoses such as seborrheic and atopic dermatitis occur commonly, whereas psoriasis and zinc deficiency are less common. Nummular eczema, neurodermatitis (lichen simplex chronicus) and adverse drug reaction should also be considered. Noneczematous dermatoses such as dermatophytosis, bullous impetigo, vesicular viral eruptions, urticarial vasculitis, mycosis fungoides and Sézary syndrome may mimic CD.

### SPECTRUM OF CONTACT DERMATITIS

Contact dermatitis is traditionally divided into ICD, accounting for 80%, and ACD, accounting for 20% of these reactions. However, there are other diseases that are caused by an external inciting factor such as contact urticaria (CU) and protein contact dermatitis (PCD).<sup>39</sup>

The innate allergenicity or irritancy of the allergen, the site of contact, the degree of contact, the exposure time to contactants, the thickness and integrity of the skin involved, the environmental conditions, the immunocompetency of the patient and genetics affect the type, severity and location of the CD. However, there is frequent overlap between ACD and ICD because many allergens at high enough concentrations can also act as irritants. Impairment to the epidermal barrier layer such as fissuring may increase allergen entry into the epidermis.

CU, a type I immediate hypersensitivity reaction, manifests as pruritic wheals after contact with the triggering substance. CU can be nonimmunologic or immunologic; the latter requires a prior sensitization phase and can spread beyond the localized contact point.<sup>40</sup>

Protein CD manifests as chronic or recurrent eczematous dermatitis (rather than urticaria) upon exposure to specific proteins such as shrimp, fish, meat or latex<sup>41,42</sup> and is thought to be caused by a combination of type I and type IV reactions.<sup>41</sup> Both CU and PCD can be caused by contact to external allergens and can respond to antihistamines and topical corticosteroids.

### ALLERGIC CONTACT DERMATITIS AND ATOPIC DERMATITIS

The relationship between ACD and AD is complex and controversial. Earlier literature suggested that patients with AD, especially severe AD, had a depressed Th1 immune system and therefore were less likely to become sensitized to allergens and develop ACD.<sup>43,44</sup> However, more recent literature suggests that development of ACD may be enhanced in patients with chronic moderate to severe AD.<sup>45-47</sup> Two later studies showed that the rates of ACD in patients are similar regardless of whether they have AD or not, the frequencies of positive patch test reactions in patients with AD being 63% to 74% and without AD 61.3% to 67%.<sup>48,49</sup> In 2010, Jacob et al reported that 95.6% of 69 children with suspected ACD had at least one positive patch test reaction, and of these, 76.7% had a history of AD.<sup>50</sup> Although

many of the common allergens seen in AD, such as fragrances and lanolin, are similar to those seen in the general population there are certain topical agents that are especially relevant in AD such as topical antibiotics (neomycin and bacitracin) and topical corticosteroids. Interestingly, bacitracin is also reported to cause contact urticaria and anaphylactic reactions. Allergic reactions to topical steroids, the mainstay of treatment of AD, have been reported not only to components of the vehicle (e.g. preservative, fragrance, emulsifier) but to the actual corticosteroid itself. Thus, although the incidence of ACD in patients with AD remains unknown, newer recommendations include the consideration of patch testing in patients with AD who are refractory to standard therapies.<sup>50</sup>

## Diagnosis of Contact Dermatitis

### HISTORY

A careful, thorough and comprehensive, age-appropriate history should include possible contact exposure of the child such as diapers, hygiene products, perfume-containing products, moisturizers, cosmetics, sun blocks, tattoos, body piercing, textiles with dyes and fire retardant, medications, pets and pet products, school projects, recreational exposure, sports, work, etc. ICD may be the cause of the dermatitis or an aggravating factor. Frequent handwashing, use of water and soaps, detergents and cleansers should be noted. The evolution of the skin reaction is influenced by many factors, including the patient's skin, age, color, ambient conditions, the use of topical or other oral medication and response to all prior treatment. Because the majority of contact reactions present as eczematous eruptions, it is essential to note clinical evolution from acute vesiculation to chronic lichenification.

Unfortunately, although history can strongly suggest the cause of CD, relying solely on the history, other than with obvious nickel reactions and a few other allergens, may confirm sensitization in only 10% to 20% of patients with ACD. CD must be considered in patients with AD because they have an impaired epidermal barrier layer and use multiple medications, creams and other topical products that subject them to a greater risk for both allergic sensitization and irritation. Also, atopy amplifies the effects of contact irritants and allergens on the skin, and contact sensitization is an aggravating factor in AD.

### PHYSICAL EXAMINATION

The diagnosis of ACD is suspected from the clinical presentation of the rash and the possible exposure to a contact allergen. CD can be described as acute, subacute or chronic. Acute dermatitis can present with erythematous papules, vesicles and even bullae. Chronic CD is generally pruritic, erythematous and may be associated with crusting, scaling, fissuring, excoriations and lichenification. ICD usually presents as well-demarcated, erythematous macules, papules and plaques confined to the area of the skin in direct contact with the offending agents, with little or no extension beyond the site of contact (Figure 53-1). ICD generally spares 'protected' areas such as the inguinal folds in diaper dermatitis. In ACD, the dermatitis can spread beyond the areas of contact and can even cause an activation of dermatitis at distant sites of prior dermatitis as in systemic CD.

Although geographic location of dermatitis can aid in the determination of the suspected allergen, other factors may



Figure 53-1 Irritant contact dermatitis of the arms.

influence the location of the dermatitis. In connubial dermatitis, the product may be transferred to the child by the parent/caregiver or to the patient by a partner. Clinically, it is difficult to differentiate CD from AD, especially in the common areas of involvement such as the eyelids, lips, hands, flexural areas of the neck, and even dermatitis with scattered generalized distribution.

A broader spectrum of ICD, including *acute*, *acute delayed*, *cumulative*, *traumatic* and *subjective*, has been described.<sup>51</sup>

## REGIONAL CONSIDERATIONS IN CHILDREN

### Hand Dermatitis

Hand dermatitis in children is extremely common. Its differential diagnosis can be challenging and it is not often studied with patch testing. Hand dermatitis may be due to ICD or ACD, AD, dyshidrosis or psoriasis. Because the skin on the palm is much thicker than that on the dorsum of the hands, ACD rarely involves the palms, occurring most often on the thinner skin between the fingers and the dorsum of the hands (Figure 53-2). However, because of significant overlap, it may be difficult to distinguish the etiology of hand dermatitis. In a study by Toledo et al,<sup>52</sup> 36% of the children with hand eczema had ACD, supporting the recommendation of patch testing of children with chronic hand eczema, independently of age, sex, personal history of atopic dermatitis or distribution of the eczema.

Patch tests in patients with hand eczema showed that relevant allergens included nickel sulfate (17.6%), potassium dichromate (7.2%), rubber elements including thiuram mix, carba mix, *p*-phenylenediamine (PPD) and mercaptobenzothiazole (MBT) (19.6%) and cobalt chloride (6.4%).<sup>53,54</sup> A





**Figure 53-2** Allergic contact dermatitis of the hand.

Swedish study of 5,700 patients showed that patients whose entire hands were involved were more likely to react to thiuram mix, *p*-phenylenediamine, chromate and BOP, while those with involvement of the fingers and interdigital spaces or palm were more likely to react to nickel, cobalt and 5-chloro-2-methyl-4-isothiazolin-3-one/2-methyl-4-isothiazolin-3-one.<sup>55</sup>

The prevalence of hand eczema in patients with AD is 2- to 10-fold higher than in nonatopics. Involvement of the dorsal aspect of the hand and fingers, combined with volar wrist involvement, suggests AD as a contributing etiologic factor. Irritant CD commonly presents as a localized dermatitis without vesicles over webs of fingers extending onto the dorsal and ventral surfaces ('apron' pattern), dorsum of the hands, palms and ball of the thumb. In contrast, ACD is often associated with vesicles and tends to favor the fingertips, nail folds and dorsum of the hands; less commonly it involves the palms. Since ICD of the hands can precede ACD, pattern changes such as increasing dermatitis from web spaces to fingertips or from palms to dorsal surfaces should prompt patch testing.<sup>56</sup>

### Face and Eyelid Dermatitis

Eyelid dermatitis may be due to ACD (55–63.5%), ICD (15%), AD (<10%) and seborrheic dermatitis (4%).<sup>57</sup> The eyelid is susceptible to ACD because of higher exposure to allergens, greater sensitivity to allergens including aeroallergens, and easy accessibility to touch, facilitating the transfer of chemicals from other areas of the body (e.g. nails, scalp) to the eyelid. Although CD is considered to be the most common cause of eyelid dermatitis, it is believed that 25% of patients with AD may have chronic eyelid dermatitis.

Pure eyelid dermatitis may be distinct from dermatitis with other areas of involvement.<sup>58</sup> Common allergens causing eyelid dermatitis are fragrances (facial tissues, cosmetics), preservatives, nickel (eyelash curlers), thiuram (rubber sponges, masks, balloons, toys), cocamidopropyl betaine and amidoamine (shampoos), tosylamide formaldehyde resin (nail polish) and gold.<sup>59</sup> Facial tissues may contain fragrances, formaldehyde or benzalkonium chloride. PPD and ammonium persulfate can cause urticaria and/or eyelid edema.

Facial dermatitis may also occur secondary to allergens transferred to the face from other regions of the body. The cosmetic industry markets heavily to children, especially the adolescent population. Cosmetics and personal products such as moisturizers, sunscreens, foundations and powders can cause ACD which tends to be symmetrical but can be patchy. The products most likely to cause ACD in the peripheral face

(pre-auricular, submental and jawline areas) are shampoos, conditioners and facial cleansers. In contrast, the products most likely to cause a central facial dermatitis (cheeks, forehead) are make-up and moisturizers. ACD that affects the lateral neck is most likely secondary to perfumes/colognes and nail cosmetics. Preservatives and fragrances are the most common allergens in patients with ACD of the face.<sup>60</sup> Rubber-sensitive individuals may react to rubber sponges, masks, balloons, children's toys and other products that are in contact with the face.

The scalp skin is relatively resistant to allergens in shampoos and hair dyes; shampoos, conditioners, hair sprays, gels and mousses may cause eyelid or facial dermatitis without causing scalp or forehead lesions. Severe burns of the scalp and hair can be caused by the misuse of hair straighteners and relaxers. The manufacturers of hair dyes recommend patch testing with the product before each application.

### Oral Mucous Membranes, Perioral Dermatitis and Cheilitis

Perioral dermatitis and cheilitis are common in children and are associated with lip licking, lip chewing, thumb sucking or excessive drooling. Objectively, changes may be barely visible or may vary from a mild erythema to a fiery red color, with or without edema. Juices of foods and even chewing gum may contribute to skin irritation of these areas. Cinnamon flavorings and peppermint are the most common causes of allergic cheilitis from toothpastes.<sup>61</sup>

Contact allergy of the mucous membrane is rare and use of patch testing to evaluate patients with mucosal involvement is controversial. In a series of 331 patients with different oral diseases (burning mouth syndrome, cheilitis, gingivitis, orofacial granulomatosis, perioral dermatitis, lichenoid tissue reaction and recurrent aphthous stomatitis), metals (nickel and gold) were most frequently positive on patch testing.<sup>62</sup> Metals, including mercury, chromate, nickel, gold, cobalt, beryllium and palladium, have been used in orthodontic materials and are important allergens in patients with dental implants or orthodontic devices presenting with oral lichenoid lesions. Other allergens with a high percentage of positive reactions on patch testing include flavorings and preservatives. 'Fragrances' are used as flavoring in food products, skin care products and dentifrices. Balsam of Peru is found in dentifrice, mouthwash, lip-stick and food. Dodecyl gallate is a preservative used to extend the shelf life of oil-based foods such as peanut butter, soups and pastries. Toothpaste, fluoride mouth washes, chewing gum and other foods may contain cinnamic aldehyde, flavorings and peppermint, which are common causes of allergic cheilitis. Thus, an oral antigen screening series in patients with cheilitis should include not only metals but also an even more comprehensive panel of flavorings, preservatives, medications and dental acrylates. The usefulness of patch testing in the evaluation of orofacial granulomatosis and recurrent aphthous stomatitis is questionable.<sup>62</sup>

### Flexural Areas of Neck and Axillary Dermatitis

The thin intertriginous skin of the neck is vulnerable to irritant reactions from 'perms', hair dyes, shampoos and conditioners. 'Berloque' dermatitis from certain perfumes or nail polish presents as localized areas of eczema. Nickel-sensitive individuals may react to wearing a necklace or to zippers.

ACD can be caused by deodorants but is rarely due to antiperspirants, the latter usually causing ICD. These agents



generally cause a dermatitis involving the entire axillary vault, whereas textile ACD spares the apex of the vault. However, sweat and perspiration may cause increased deodorant allergen in the periphery, giving a dermatitis that is less intense in the apex of the axillae. ACD due to disperse dyes such as disperse Orange 1, disperse blue 106 and disperse blue 124 in clothing can elicit eczematous eruptions in the axillae, arms and groin.<sup>63–65</sup>

### Diaper Dermatitis

Eruptions in the diaper area are the most common dermatologic disorder of infancy.<sup>66</sup> Friction, occlusion, maceration and increased exposure to water, moisture, urine and feces<sup>67</sup> contribute to ICD. The prevalence of diaper dermatitis, an ICD, in infants has been estimated to be 7% to 35% with a peak incidence between ages 9 and 12 months.<sup>68</sup> However, a large-scale study in the UK demonstrated an incidence of 25% in the first 4 weeks of life alone.<sup>69</sup>

Allergic CD to rubber chemicals (mercaptobenzothiazole, cyclohexyl thiophthalimide) or glues (*p*-tertiary butylphenol-formaldehyde resin) has been called ‘Lucky Luke’ CD.<sup>70</sup> The characteristic dermatitis is predominantly located on the outer buttocks and hips in toddlers (‘gun holster’ pattern) and is caused by the elastic bands that hold tightly on the thighs to prevent leaking. Treatment usually involves increasing the frequency of diaper changes, using superabsorbent disposable diapers and applying low-potency corticosteroids and barrier ointments or creams. A topical antifungal agent is beneficial in secondary *Candida albicans* infection. There has been a definite decrease in the incidence of diaper dermatitis due to the availability of newer and improved diapers, including those with superabsorbent gel.<sup>71</sup>

Medication, douches, spermicides, sprays and cleaners can cause CD in the genital area. Fragrances found in liners, toilet paper, soap and bubble baths can cause a reaction in sensitized patients. Contraceptive devices can affect rubber- and latex-sensitive individuals. Ammonia and/or the acidity of urine may cause ICD, especially in incontinent patients. The ingestion of spices, antibiotics or laxatives may cause anal itching.

### Leg and Foot Dermatitis

Shaving agents, moisturizers and rubber in the elastic of socks can cause allergic reactions in children. Romaguera and Vilaplana<sup>72</sup> found that the foot was the most frequent localization of CD in children. Irritant dermatitis of the feet may occur in children because of excessive perspiration or the use of synthetic footwear. More commonly, children can develop ACD to rubber accelerators (MBT mix, thiuram mix, carba mix, and PPD mix), dichromates (Figure 53-3) or glues used in the manufacture of shoes. Chrome used in the tanning and dyeing processes of leather, and colophony used in glues in soles and insoles, may be sensitizing. Other chemicals in footwear (e.g. leather, adhesives, glues and dyes) or in topical medications (e.g. creams, ointments and antiperspirants) can cause ACD. Reactions to nickel sulfate were also frequent with metal in footwear buckles, eyelets and ornaments.<sup>73</sup> In ACD, the involvement of the dorsal aspect of the foot and toes, especially the hallux, and sparing of the interdigital areas is characteristic. Irritant dermatitis can involve either the dorsum or the sole. Patients with hyperhidrosis or ‘sweaty sock’ dermatitis should be encouraged to wear cotton socks and to change them frequently, along with wearing breathable footwear.



**Figure 53-3** Chronic dermatitis on dorsa of feet and toes caused by potassium dichromate allergy from chronic exposure to leather tennis shoes. (From Weston WL, Lane AT, Morelli JG. *Dermatitis. Color textbook of pediatric dermatology*. 4th ed. Mosby; 2007.)

### Generalized Dermatitis

Dermatitis with scattered generalized distribution (SGD) is a difficult diagnostic and therapeutic challenge because it lacks the characteristic distribution that gives a clue as to the possible diagnosis of ACD. Interestingly, the most common body location of dermatitis for both children and adults reported by the NACD in 2013 was scattered/generalized pattern, followed by the hands and then the face.<sup>74</sup> Zug and colleagues<sup>75</sup> reported that approximately half (49%) of patients with SGD referred for patch testing had a positive patch test deemed at least possibly relevant to their dermatitis, the prevalence being higher in patients with a history of AD. The two allergens most commonly identified were nickel and BOP. Hjorth<sup>76</sup> reported two children who were patch test positive to BOP whose eczema flared after oral intake of naturally occurring balsams. Other relevant positive patch test reactions included preservatives (formaldehyde, quaternium 15, methylidibromoglutaronitrile/ phenoxyethanol, diazolidinyl urea, 2-bromo-2-nitropropane-1, 3-diol, imidazolidinyl urea, and DMDM hydantoin) and propylene glycol. Dyes such as disperse blue 106 in synthetic fibers in children’s garments have also been implicated.<sup>11</sup>

Advising patients to use skin care products without the most frequent, relevant allergens (formaldehyde-releasing preservatives, fragrances and propylene glycol) is one strategy that may be helpful while awaiting definitive patch testing results. However, 8% to 10% of patients with SGD remain in the unclassified eczema category.<sup>75</sup>

Systemic CD should be considered as a possible cause of dermatitis with SGD. It manifests as a localized or generalized inflammatory skin disease that occurs in sensitized individuals when they are exposed to the specific allergen orally, transcutaneously, intravenously or by inhalation. There are a variety of manifestations of systemic CD reactions including a reactivation of a previous dermatitis, reactivation of a previously positive patch test (localized ‘recall reactions’), a systemic inflammatory skin disease such as the ‘baboon syndrome’<sup>77–81</sup> and/or oral lichenoid reactions. Patients allergic to ethylenediamine may react to systemic aminophylline and antihistamines of the piperazine or ethanolamine families. Similar reactions have been reported to glucocorticoids, diphenhydramine,

**TABLE 53-1** Reported Causes of Systemic Allergic Contact Dermatitis

Contact Sensitizer	Systemic Reaction to
Glucocorticoids	Oral hydrocortisone
Benadryl cream®	Oral diphenhydramine
Neomycin	Oral neomycin
Penicillin	Oral penicillin
Sulfonamide	Para-amino sulfonamide hypoglycemics (tolbutamide, chlorpropamide)
Thiuram	Antabuse
Colophony, Balsam of Peru, fragrance mix	Spices: clove, nutmeg, cinnamon, cayenne pepper Citrus fruits: oranges, lemon, tangerines Tomatoes
Ethylenediamine	Aminophylline (alternative: oral theophylline, IV theophylline) Piperazine and ethanolamine (Atarax®, Antivert®) (alternatives: diphenhydramine, chlorpheniramine, fexofenadine)
Nickel	Nickel in tap water, utensils and food high in nickel content such as soy, chocolate, lentils, cashews
Chromate	Inhaled chromium: oral potassium dichromate

neomycin, penicillin, sulfonamides, thiuram, colophony, BOP, fragrance mix and nickel (Table 53-1).

## Patch Testing

Unfortunately, even with an extensive history and physical exam, only about 10% to 20% of patients with ACD can be diagnosed accurately without patch testing. Patch testing is needed to identify the responsible allergens, is helpful in young children suspected of ACD and remains the gold standard for confirming ACD. Although the application of antigens for patch testing is rather simple, antigen selection and patch test interpretation require an experienced clinician (Table 53-2).

### SELECTION OF APPROPRIATE SUBJECTS TO TEST

The higher the index of suspicion, the more frequent the diagnosis of ACD. Patch testing should be considered for children with a chronic, pruritic or recurrent eczematous dermatitis, especially those with eyelid or hand involvement,<sup>82</sup> those with uncontrollable or worsening chronic dermatitis of greater than 2 months duration and those who fail to improve following standard treatment protocols including a preliminary avoidance regimen of formaldehyde and fragrance. Indeed, the observation that the greatest abuse of patch testing is its lack of use holds true even for the pediatric population. Immunocompromised patients, including those on oral steroids or those on cancer chemotherapy or immunosuppressive drugs, are not appropriate candidates for patch testing. Ideally, the patient's dermatitis should be quiescent because flare-up reactions may be elicited during patch testing. The patch test site should have had no potent topical immune modulators or steroid applied for 5 to 7 days before testing. Patients should avoid sun or

**TABLE 53-2** Patch Test Interpretation Based on The Recommendation of The International Contact Dermatitis Research Group

Grade	Patch Test Grading
(-)	Negative reaction
(?+)	Doubtful reaction with faint erythema only
1+	Weak positive reaction with nonvesicular erythema, infiltration, possible papules
2+	Strong positive reaction with vesicular erythema, infiltration and papules
3+	Extreme positive reaction with intense erythema and infiltration coalescing vesicles, bullous reaction
IR	Irritant reaction

ultraviolet light exposure for 96 hours. Systemic antihistamines have no effect on patch test results. However, not all children with suspected ACD can have patch testing. Given the smaller surface area for patch testing, especially in young children, if comprehensive patch testing cannot be done, a detailed exposure history may guide the choice of potential allergens to test based on the history of exposures and the patient's own personal care products.

### SOURCES OF ALLERGENS

Commercially available standardized patch testing allergens have been calibrated with respect to nonirritant concentrations and compatibility with the test vehicle. Test systems currently available in the USA are the T.R.U.E. TEST® and the standardized allergens loaded in patch test chambers. Certain screening panels such as the NACD recommended series or the American Contact Dermatitis Society Core Allergen Series, with a range from 65 to 70 allergens are not approved by the US Food and Drug Administration (FDA) but conform to standards of care recommended by CD experts. Commercial sources of customized patch test materials include Smart Practice Canada (1.866.903.2671), SmartPractice Europe +49 (0)40 6701768 and Dormer Laboratories, Inc. (416-242 6167) (chemotechnique@dormer.com).

### ALLERGENS

The German Contact Dermatitis Group (GCDG)<sup>83</sup> recommends that children under 6 should only be subjected to patch testing if there is a high degree of clinical suspicion and that only the suspected allergens should be used. Some authors suggest dose adjustment in younger children for allergens such as nickel, formaldehyde, formaldehyde releasers, mercaptobenzothiazole, thiuram and potassium dichromate to avoid irritant false-positive reactions.<sup>84,85</sup> Jacob et al recommend a reduced concentration of nickel, formaldehyde and rubber additives in children under 5, especially in those who also have AD.<sup>86</sup> Children over the age of 12 can be tested in the same manner as adults and most studies to date suggest that the same test concentrations as in adults can be used.<sup>87</sup>

The ideal number of patch tests to be applied depends on the patient. The usefulness of patch testing is enhanced with the number of allergens tested. Allergens not found on commercially available screening series in the USA frequently give relevant reactions, and personal products are a useful supplement especially in facial or periorbital dermatitis.

A 2011 Pediatric Research Equity Act (PREA)-1 found that the T.R.U.E. TEST<sup>®</sup> test with 29 patches was efficacious and safe, in a study of 102 children aged 6 to 18 years.<sup>88</sup> Since then seven more allergens have been added to the T.R.U.E. TEST<sup>®</sup>, whose safety and efficacy in pediatric age groups are still being studied (Table 53-3). Comparative results of the T.R.U.E. TEST<sup>®</sup> and Finn Chamber method have shown a 64% to 98% concordance, depending on the allergen.

However, a further study suggested that false-negative results may occur with the T.R.U.E. TEST<sup>®</sup>, particularly with fragrance mix and rubber additives (thiuram and carba mix),<sup>89</sup> as well as to neomycin, cobalt and lanolin.

Other standardized allergens can be tested individually with a loading chamber such as the Finn Chamber but clinicians need to be aware of the limitations of each system of patch testing for individual allergens.<sup>90</sup> Caution should be exercised when testing for nonstandardized antigens to avoid adverse effects and false-positive or -negative responses. Ideally, at least two control subjects should be tested with any nonstandardized allergen. 'Leave-on' cosmetics (make-up, perfume, moisturizer, nail polish), clothing and most foods are tested 'as is', whereas 'wash-off' cosmetics (soap, shampoo) are tested at 1 : 10 to 1 : 100 dilution.

Patch testing should never be performed with an unknown substance. Photopatch tests should be performed by physicians with expertise in ultraviolet radiation if photocontact dermatitis is suspected. Additional guidelines for patch testing, including strength of recommendations and quality of evidence, have been published by the British Association of Dermatologists' Therapy Guidelines and Audit Subcommittee.<sup>91</sup> The T.R.U.E. TEST<sup>®</sup> may serve as triage or a screening tool in an allergist's practice but occupational exposures may benefit from early referral for supplemental testing.

## SELECTION OF ALLERGENS IN CHILDREN

The North American Contact Dermatitis Group (NACDG) seeks to determine the frequency of positive and relevant patch tests in children referred for patch testing in North America and to compare results of patch testing in children and adults, as well as results with international data on contact allergy in children. No significant difference in the overall frequency of at least one relevant positive patch test reaction was noted in children (51.2%) compared with adults (54.1%).<sup>8</sup> In a more recent meta-analysis, the top five most prevalent allergens in the pediatric population that should have priority for inclusion in standardized testing are nickel sulfate, ammonium persulfate, gold sodium thiosulfate, thimerosal and toluene-2,5-diamine (*p*-toluenediamine).<sup>92</sup>

The top ten most commonly positive allergens in the pediatric population in North America are nickel, neomycin, cobalt, fragrance, *Myroxylon pereirae* (BOP), gold, formaldehyde, lanolin/wool alcohols, thimerosal and potassium dichromate.<sup>8</sup> Eight of these allergens are also in the top 10 allergens seen in adults.<sup>74</sup> The two allergens in children but not in adults are lanolin/wool alcohols, which can be found in healing ointments, aftershave, baby and bath oil, hand sanitizers and creams, and thimerosal, which is likely a sensitization due to previous vaccination and is not a relevant allergen.

There are additional highly relevant allergens in children which correlate with unique exposures such as (1) methylchlorosiothiazolinone/ methylisothiazolinone (MCI/MI), a

chemical preservative found in infant products such as wet wipes, protective creams, liquid soaps and shampoos; (2) cocamidopropyl betaine (CAPB), a surfactant used in cleansing products (e.g. No More Tears<sup>™</sup> formulations); (3) disperse dyes found in diaper material and colored garments such as school and athletic uniforms; (4) carbamates and thiuram used in rubber production found in gloves, garments, shoes and toys; (5) dialkyl thioureas; and (6) *p*-*tert*-butyl formaldehyde resin found in rubber and neoprene components in shin guards, protective pads and wetsuits.

Thus Jacob et al<sup>93</sup> recommend a basic North American Standard Series for children aged 6 to 12 years to include 20 selected allergens that are the most prevalent in the pediatric population with the highest clinical relevance and therefore would be the highest yield as a basic series. An additional five other allergens could be tested for if there is a relevant exposure history. Table 53-3 gives the most common source of exposure for some significant allergens. Similarly, due to the limited surface available for testing and the potential risk of active sensitization, the GCDRG<sup>83</sup> recommends an even more limited panel of 12 contact allergens as a standard series in children from 6 to 12 years of age. When history suggests exposure to shoe allergens, *p*-*tert*-butylphenol-formaldehyde resin and potassium dichromate are added. Wool alcohols/lanolin is added when there is exposure to skin care products, disperse blue if clothing dermatitis is suspected and *p*-phenylenediamine if there is exposure to henna, tattoos and hair dyes. Table 53-4 compares the recommended allergens for patch testing in children 6 to 12 years of age and the secondary allergens to test based on the recommendations of Jacob and the GCDRG. Of note, 15% and 39% of children had relevant allergens not included in the NACDG series or T.R.U.E. TEST<sup>®</sup>, respectively, hence the need for supplemental allergens as well as the patient's personal products in some cases. It is important to remember that the majority of patients will be allergic to a single allergen or a single group of allergens and that there is a risk of false-positive patch test results. Ideally, one needs to know the value of all the clinical data before patch testing, in predicting a clinically relevant response to any of the allergens tested.

## PATCH TESTING PROCEDURE

Standardized criteria for patch testing have been set by the Task Force on Contact Dermatitis of the American Academy of Dermatology. All results are dependent on the recommended protocol for application, removal and interpretation of results.

Patch tests are typically applied to the upper- or mid-back areas (2.5 cm lateral to a mid-spinal reference point) which must be free of dermatitis and hair and are kept in place for 48 hours. Patients are instructed to keep the area dry and avoid activities that will cause excessive sweating or excessive movement that may cause displacement of the patches. In infants and small children, the patch test can be covered with fabric adhesive tape or a stockinet vest. Patch tests are removed after 48 hours and read 30 minutes after to allow resolution of erythema and irritative effect from the tape and/or chamber if present. A second reading should be done 3 to 5 days after the initial application. Thirty percent of relevant allergens negative at the 48-hour reading become positive in 96 hours. Irritant reactions tend to disappear by 96 hours. Metals (gold, potassium dichromate, nickel, cobalt), topical antibiotics (neomycin, bacitracin), topical corticosteroids and PPD may become positive after 7

**TABLE 53-3 Thin-layer Rapid Use Epicutaneous Test (T.R.U.E. TEST®) Antigens**

Antigen	Common Exposures
<b>PANEL 1.2</b>	
Nickel sulfate	Snaps, jewelry, food
Wool alcohols (lanolin)	Cosmetics (lipstick, hair spray), skin care products (creams, ointments, lotions, moisturizer, baby oil, diaper lotion), personal hygiene items (soaps, cleansers, shampoos), facial masks, sunscreens, over-the-counter and prescription medications for skin rashes, pet grooming aids
Neomycin sulphate	Topical antibiotics
Potassium dichromate	Chrome-tanned leather products (shoes, boots, gloves), cement, pigments in inks and paints, make-up
Caine mix	Topical anesthetics
Fragrance mix	Fragrances, scented household products
Colophony	Cosmetics, sunscreens, adhesives, household products, diapers, feminine napkins, wax depilatories, match tips
Paraben mix	Preservative in topical formulations, cosmetics
Negative control	
Balsam of Peru	Cosmetics, fragrances, dental hygiene products, topical medications, food
Ethylenediamine dihydrochloride	Topical medications, piperazine-related antihistamines, aminophylline, hydroxyzine hydrochloride
Cobalt dichloride	Metal-plated objects (utensils, keys, magnets, clothing fasteners, jewelry), paints, cobalt-based pigments, vitamin B <sub>12</sub> supplements
<b>PANEL 2.2</b>	
<i>p</i> - <i>tert</i> -Butylphenol-formaldehyde resin	Fabrics, glued rubber (rubber-containing footwear, handbags, watchbands, belts, bras), sports gear, leather goods
Epoxy resin	Two-part adhesives and paints, art and sculpture materials, manufacture of tennis racquets, skis, circuit boards, lightweight equipment
Carba mix	Rubber products, shampoos, disinfectants
Black rubber mix	All black rubber products (tires, playgrounds), some hair dyes
CL+ ME– Isothiazolinone (MCI/MI)	Cosmetics (foundations, powders, blush, mascaras, eye shadows, eyeliners and pencils), skin care products (creams, lotions, moisturizers, soaps, cleansers, bubble baths, wipes), hair care products (conditioners, shampoos, coloring agents), laundry products (detergents, fabric softener)
Quaternium-15	Preservative in cosmetics and skin care products
Methyldibromo glutaronitrile	Skin care products such as body creams, facial/hand lotions, sun screens, and baby lotions Personal hygiene products such as moist toilet paper, shampoos, conditioners and shower gels
<i>p</i> -Phenylenediamine	Permanent or semipermanent hair dyes, cosmetics, printing ink, black henna tattoo
Formaldehyde	Fabric finishes, cosmetics
Mercapto mix	Rubber products, glues for leather and plastics
Thimerosal	Preservative in contact lens solutions, cosmetics, injectable drugs
Thiuram mix	Rubber products, adhesives
<b>PANEL 3.2</b>	
Diazolidinyl urea	Products for personal care, hygiene and hair care; cosmetics; pet shampoos
Quinoline mix	Paste bandages; prescription and non-prescription topical antibiotics and antifungal creams, lotions, ointments; animal food
Tixocortol-21-pivalate	Antiinflammatory preparations
Gold sodium thiosulfate	Gold or gold-plated jewelry, dental restorations
Imidazolidinyl urea	Products for personal care, hygiene and hair care; cosmetics; liquid soaps; moisturizers
Budesonide	Corticosteroid creams, lotions and ointments, nasal corticosteroid spray; asthma controller medication in inhaler, nebulized suspension and dry powder forms
Hydrocortizone-17-butyrate	Antiinflammatory preparations
Mercaptobenzothiazole	Rubber products, nitrile or neoprene, such as rubber bands, ear- and headphones, masks, condoms and diaphragms, goggles, shoes, utility gloves, swimwear, toys, hoses, tubing and elastic Sports equipment made with natural rubber, butyl rubber, nitrile or neoprene such as shoes, wetsuits, boots, masks, racquet and club handles
Bacitracin	Prescription and in over-the-counter preparations such as topical antibiotic creams, lotions, ointments, bandages, ophthalmic and otic products
Parthenolide	Plants and gardens, herbal teas containing sesquiterpenes, supplements, tablets or tinctures
Disperse blue 106	Synthetic fabrics such as polyester, acetate, nylon with black or navy blue color; dark-colored polyester velour and in children's diapers and exercise garments; dyed fabrics such as bedding, clothing, nylon stockings, swimming suits, tights, velour, children's diapers
2-Bromo-2-nitropropane-1,3-diol (Bronopol)	Topical antibiotic/antifungal creams/ointments, finger paints, kitty litter, detergents, toiletries and cleansers, cleansing lotions, creams, foundations, hair conditioners, mouthwash, shampoos



TABLE 53-4

**Comparison of Patch Test Recommendations  
By Jacob et al and German Contact  
Dermatitis Research Group for Children 6 to  
12 Years of Age**

Allergen	Jacob et al	GCDRG
Bacitracin	1. Primary*	
Budesonide	2. Primary	
Carba mix	3. Primary	
Cobalt chloride	4. Primary	
Cocamidopropyl betaine	5. Primary	
Colophonium	6. Primary	1. Primary
Compositae mix/dandelion extract	7. Primary	2. Primary
Disperse blue	8. Primary	Secondary†
Ethylenediamine	9. Primary	
Formaldehyde	10. Primary	
Fragrance mix 1	11. Primary	3. Primary
Fragrance mix 2	12. Primary	4. Primary
Lanolin alcohol	13. Primary	Secondary
MCI/MI	14. Primary	5. Primary
<i>Myroxylon pereirae</i> (Balsam of Peru)	15. Primary	
Neomycin sulfate	16. Primary	6. Primary
Nickel sulfate	17. Primary	7. Primary
Potassium dichromate	18. Primary	Secondary
Quaternium 15	19. Primary	
Tixocortol-21-pivalate	20. Primary	
Thiuram		8. Primary
Mercaptobenzothiazole	Secondary	9. Primary
mercapto mix		10. Primary
bufexamac		11. Primary
dibromodicyanobutane		12. Primary
black rubber mix <sup>2</sup>	Secondary	
dialkyl thioureas <sup>9</sup>	Secondary	
para-phenylenediamine <sup>2,9,12,13,17</sup>	Secondary	Secondary
<i>p</i> -tert-butylphenol formaldehyde resin <sup>2,9,13</sup>	Secondary	Secondary

\*Primary allergens: most prevalent in the pediatric population with the highest clinical relevance and therefore would be the highest yield as a basic series.

†Secondary allergens: additional significant allergens that could be tested for if there is a relevant exposure history.

GCDRG – German Contact Dermatitis Research Group;

MCI/MI – methylchloroisothiazolinone/methylisothiazolinone.

days. More than 50% of positive patch testing to gold was delayed for about 1 week.

The International Contact Dermatitis Research Group has developed a grading system that is almost universally recognized and continues to be widely used (Table 53-2).

### DETERMINING CLINICAL RELEVANCE

The relevance of positive reactions to clinical ACD can only be established by carefully correlating the history, including exposure to the allergen. A positive patch test reaction may be relevant to present or previous dermatitis, multiple true-positives

TABLE 53-5

**Relevance**

Definite	If a use test with the putative item containing the suspected allergen is positive or positive patch to object/product
Probable	If the substance identified by patch testing can be verified as present in the known skin contactants of the patient
Possible	If the patient is exposed to circumstances in which skin contact with materials known to contain the putative allergen will likely occur
Past	If the patient had previous exposure but is currently not exposed
Unknown	

**BOX 53-1 STRUCTURAL GROUPS OF CORTICOSTEROIDS: CROSS-REACTIVITY BASED ON TWO IMMUNE RECOGNITION SITES – C 6/9 AND C16/17 SUBSTITUTIONS**

**Class A** (hydrocortisone and tixocortol pivalate: has C17 or C21 short chain ester)

Hydrocortisone, -acetate, tixocortol, prednisone, prednisolone, -acetate, cloprednol, cortisone, -acetate, fludrocortisone, methylprednisolone-acetate

**Class B** (acetonides: has C16 C17 *cis*-ketal or -diol additions)

Triamcinolone acetonide, -alcohol, budesonide, desonide, fluocinonide, fluocinolone acetonide, amcinonide, halcinonide

**Class C** (nonesterified betamethasone; C16 methyl group)

Betamethasone sodium phosphate, dexamethasone, dexamethasone sodium phosphate, flucortolone

**Class D1** (C16 methyl group and halogenated B ring)

Clobetasone 17-butyrate, -17-propionate, betamethasone-valerate, dipropionate, alclometasone dipropionate, flucortolone caproate, -pivalate, mometasone furoate

**Class D2** (labile esters w/o C16 methyl nor B ring halogen substitution)

Hydrocortisone 17-butyrate, -17-valerate, -17-aceponate, -17-buteprate, methylprednisolone aceponate

Wilkinson, SM. Corticosteroids cross reactions: an alternative view. *Contact Dermatitis* 2000;42:59–63.

can occur, and mild responses may still represent allergic reaction. Conversely, patients with negative results may need to be referred for more complete testing to a patch testing clinic. Thus, understanding the sources of antigen in the patient's environment is required to be able to advise the patient adequately regarding avoidance and alternatives in ACD. A positive patch test is considered to be a 'definite' reaction of ACD if the result of a 'use test' with the suspected item was positive or the reaction of the patch test with the object or product was positive. It would be 'probable' if the antigen could be verified as present in known skin contactants and the clinical presentation was consistent, and 'possible' if the patient is exposed to circumstances in which skin contact with materials known to contain allergen was likely (Table 53-5). Multiple sensitivities are possible if different allergens are present in different products used simultaneously, or concomitant sensitization occurs if allergens are present in the same products and both induce sensitization. Cross-sensitization can also occur. Common combinations of a

positive patch test are: PPD and benzocaine (cross-sensitizer); thiuram mix, carba mix and mercapto mix (rubber products); quaternium 15 and paraben (quaternium-15, a formaldehyde releaser, and paraben are preservatives that are frequently combined and cosensitize); cobalt and nickel (cobalt is used in alloys with nickel and chromium and cosensitize). Polysensitization is common in children.

The repeat open application test (ROAT) or exaggerated use test may be done to confirm the presence or absence of ACD. The suspected allergen (for 'leave-on' but not 'wash-off' products) is applied to the antecubital fossa twice daily for 7 days, and observed for dermatitis. The absence of a reaction makes CD unlikely. If eyelid dermatitis is considered, ROAT can be carried out on the back of the ear.

Additional tests used less frequently in the diagnosis of CD include skin biopsy to differentiate from other diseases. Prick or intradermal testing may be helpful, especially in the evaluation of contact urticaria. Contact urticaria can also be evaluated with an 'open' patch test. Potassium hydroxide preparation for fungal hyphae or cultures may be needed to identify fungal disease.

## Allergens of Particular Importance in Children

### NICKEL

Nickel is a more common cause of ACD than all other metals combined, even in children. Of 391 children aged 18 years or less who were patch tested by the NACDG, 28% had a positive patch test to nickel, and 26% were deemed to have a nickel allergy of either current or past relevance.<sup>94</sup> Nickel allergy is more common in adolescents, girls more than boys, and ear piercing is the most important predisposing factor. The prevalence of nickel allergy among children with pierced ears was 13% compared to 1% among those without.<sup>95</sup> The risk of sensitization to nickel appears higher when earlobes are pierced before the age of 20 years ( $P < .05$ )<sup>96</sup> and is increased with the number of piercings.<sup>97</sup> Thus, some authors recommend that ear piercing be delayed until after 10 years of age, presumably to allow for the development of immune tolerance.<sup>98</sup>

Nearly 5 million people in the USA and Canada undergo orthodontic treatment. In patients with contact allergy to orthodontics, nickel is the most common allergen. Nickel is commonly used in orthodontics; stainless steel, which contains about 8% nickel that is not normally biologically available, is generally considered safe in nickel-allergic patients. Certain flexible titanium-nickel arch wires used in orthodontics release increased amounts of nickel compared to stainless steel and may need to be avoided in patients with known nickel sensitivity.<sup>99</sup> A Finnish study of adolescents found that 35% of the girls who had their ears pierced prior to orthodontic treatment were nickel allergic versus none of the girls who had orthodontic treatment prior to ear piercing.<sup>100</sup> The mechanism responsible was suggested to be oral tolerance.<sup>101</sup> In females, nickel sensitivity may increase the risk of developing hand eczema.<sup>102</sup> The presence of releasable nickel from the surface of any object can be detected using the dimethylglyoxime spot test; a pink color indicates the presence of releasable nickel. Despite some studies suggesting benefit,<sup>103,104</sup> the evidence for dietary avoidance of nickel is not strong (quality of evidence IV, strength of recommendation C).<sup>91</sup>

### CHROMATE

Chromates are commonly found in products made of chrome and stainless steel, cement and leather. They are found in shoes and gloves, where chromium salts are used in the tanning process. Chromate sensitivity can be associated with hand or foot dermatitis, which can persist even after chromate avoidance.

### THIMEROSAL

Thimerosal is a mercuric derivative of thiosalicylic acid used as a preservative in vaccines, cosmetics, tattoo inks, eye drops and contact lens solutions as well as a disinfectant (e.g. merthiolate).<sup>105,106</sup> It may cross-react with mercury, which is used as a preservative material in shoe manufacturing. The NACDG reported thimerosal as the fifth most common allergen, inducing allergic reactions in 11% of patch-tested patients,<sup>107</sup> with only 17% of the positive patch tests considered clinically relevant, ranking thimerosal last in relevance among the 50 allergens tested. Sensitization to thimerosal is associated with routine vaccination and this sensitization is lifelong. Thus a positive patch test to thimerosal may not have current relevance. However, thimerosal can still be found in ophthalmic solutions and some eye make-up and may have relevance in eyelid dermatitis. Because of its potential toxicity and allergenicity in children, precautionary measures are underway to remove thimerosal from vaccines.<sup>108</sup> Notably, sensitization to thimerosal is not a contraindication to vaccination<sup>109-111</sup> and the only vaccine for children under 6 years of age that still contains thimerosal is the inactivated influenza vaccine in the multi-dose units; the single-dose units do not contain thimerosal.<sup>112</sup> Thimerosal's removal from the allergy patch testing screening tray has been recommended.<sup>113</sup>

Aside from thimerosal, reactions to adjuvants (e.g. aluminum hydroxide), stabilizers (e.g. gelatin), preservatives and antibiotics (e.g. neomycin) in vaccines have been reported.

### ALUMINUM

Aluminum may cause cutaneous granulomas in response to vaccines containing aluminum hydroxide. These tend to resolve spontaneously, although children subsequently have positive patch tests to metallic aluminum or its salts.<sup>114</sup> The aluminum sensitivity appears to be lost with time as it occurs rarely in adults.

### RUBBER CHEMICALS

Rubber chemicals (thiuram mix, mercaptobenzothiazole, mercapto mix) are used in the manufacturing of both dipped (e.g. balloons, gloves) and molded (e.g. pacifiers, handle bars) rubber products. Mixed dialkyl thioureas (MDTU), a mixture of two thiourea chemicals, is used for rubber acceleration and as an antioxidant in the manufacturing of neoprene. Large quantities of thioureas have been shown to leach from neoprene compounds and the levels were sufficient to elicit ACD.<sup>115</sup> This allergen mixture has one of the highest relevancy rates in the NACDG database. ACD from neoprene includes cases caused by orthopedic braces, prostheses, splints and foot supports; athletic shoes; rubber masks, swim goggles and wet suits; computer wrist rests; neoprene gloves; and rubber-based materials in automobiles.

## Special Considerations

### PLANT DERMATITIS (PHYTODERMATOSES)

A number of plants can cause irritant reactions through mechanical or chemical injury. Most mechanical injury from plants is trivial, although inoculation of cactus hairs can cause pruritus. 'Itching powder' from rose hip hairs has caused maculopapular, and sometimes pustular, eruptions at sites of contact. Chemical irritation caused by oxalate crystals results from contact with mustard, horseradish and capsaicinoids in chili peppers. Contact with stinging nettles injects a mixture of inflammatory mediators, including histamine, causing a hive, and an unidentified neurotoxin that causes localized numbness and tingling.

Plants of the *Toxicodendron* group, including poison ivy and poison oak, are the most common causes of allergic plant dermatitis in children in the USA. Even newborns can be sensitized to the oleoresin (urushiol). The clinical reaction is typically vesicles and bullae, often with a characteristic linear appearance. Although the fluid content of vesicles is not antigenic, the oleoresin can be transferred by handling exposed pet dander, clothing or sports equipment. Soap and water inactivate the antigen. Urushiol is also found in cashew nut trees, Japanese lacquer, *Ginkgo biloba* and mango skin, and the ingestion of cashews or contact with mango skin can cause a similar rash. Rhus patch testing is not recommended because it has a significant sensitizing capacity.

The Compositae family (Asteraceae), the second largest plant family, represents approximately 10% of the world's flowering plants. ACD to Compositae may manifest as acute or chronic dermatitis of exposed sites. Although ACD to Compositae is typically seen in florists, farmers and professional gardeners, recent studies indicate that it may be more common in children than previously believed. Patch test reactions on screening with two different Compositae mixes detected 4.2% and 2.6% positives among children and adolescents, with significantly higher positive results in children with AD.<sup>116</sup> The dermatitis has an airborne contact pattern distribution in the exposed areas of the hands and face with symptoms worse in late spring or summer and worse after picking daisies, dandelions or playing outdoors. Belloni Fortina and colleagues<sup>117</sup> suggested adding Compositae mix to the pediatric screening series when investigating dermatitis of air-exposed areas in children with AD; however, this carries the risk of false-positive results or sensitization. Cross-reactivity between fragrance terpenes and Compositae plant extracts may be a cause of false-positive patch testing to Compositae.<sup>118</sup> In summary, ACD to Compositae should be suspected in children with a family or personal history of atopy, summer-related or -exacerbated dermatitis and a history of plant exposure.

*Ambrosia* species, which include ragweed, can cause allergic plant dermatitis when pollinating, in both atopic and nonatopic individuals. Repeated contact with ornamental cut flowers, including *Alstroemeria* (the lily and tulip family of plants), can result in an ACD that presents with a fissured dermatitis of the fingertips. Plants that contain furocoumarins (psoralens), including parsley, parsnips and wild carrots, can cause phototoxic reactions, especially in summer when psoralens are most abundant in the plants where children are playing. These reactions occur when the skin, contaminated with psoralens, is exposed to ultraviolet A light.

### DERMATITIS FROM TOPICAL MEDICATIONS

The topical application of anesthetics, antihistamines, antibiotics and even antiinflammatory drugs along with preservatives or fragrances has been implicated in sensitization and contact reactions. Neomycin and topical diphenhydramine are frequent and potent sensitizers in children. Contact allergy to topical corticosteroids can be difficult to diagnose<sup>119</sup> and should be suspected in patients whose dermatitis worsens with the application of a corticosteroid. There have been reports of contact allergy in the nasal mucosa to budesonide nasal spray and stomatitis with budesonide for oral inhalation.<sup>120</sup> Patch testing to some corticosteroids is commercially available but because of concurrent antiinflammatory action, delayed readings beyond 72 hours have to be done. Corticosteroids representative of different structural groups A-D with cross-reactivity based on two immune recognition sites – C 6/9 and C16/17 substitutions – are typically used in patch testing<sup>121</sup> (Box 53-1). Cross-reactivity within a group is higher than between agents in different groups. The currently available T.R.U.E. TEST<sup>®</sup> contains tixocortol (Class A), budesonide (Class B) and hydrocortisone-17-butyrate (Class D2).

### CONTACT DERMATITIS TO COSMETICS

An average adult applies 12 personal hygiene products daily and, in the course of using these products, is exposed to 168 discrete chemicals. Children, especially adolescents, may be exposed to similar numbers. Exposure to multiple potential allergens occurs repeatedly with the use of cosmetics and it is not unusual for these products to manifest as contact allergy distant from the sites of application (termed *ectopic contact dermatitis*).

Fragrance is the most common causes of ACD from cosmetics in the USA. Fragrances can be found in cosmetics, personal hygiene products, diapers and even scented toys, either overtly to add an appealing scent or to mask unpleasant odors.

The term *unscented* can erroneously suggest that a product does not contain fragrance when, in fact, a masking fragrance can be present. *Fragrance-free* products are typically free of classic fragrance ingredients and generally acceptable for the allergic patient. However, if a fragrance-based chemical (such as the preservative benzyl alcohol) is added for a purpose other than to act as a fragrance, the product can still claim that it is fragrance free. The addition of botanical and natural chemicals can also alter the smell of the product. The fragrance mix that is popularly used for patch testing contains eight different fragrances and together with BOP will diagnose approximately 60-70% of fragrance-allergic individuals. Fragrance Mix II is one of the top 10 most frequently positive allergens of the NACD 2009–2010 patch test but is not included in the current T.R.U.E. TEST<sup>®</sup> and may therefore be missed.

Preservatives, present in most aqueous-based cosmetics and personal hygiene products to prevent rancidity, are grouped into two broad categories: formaldehyde releasers and non-formaldehyde releasers (Table 53-6). Individuals who are allergic to formaldehyde cannot use any of the formaldehyde releasers. Paraben is the most commonly used preservative in cosmetic, pharmaceutical and industrial products because of its broad spectrum of activity against yeasts, molds and bacteria.

Excipients, including propylene glycol, ethylenediamine and lanolin, serve to solubilize, sequester, thicken, foam or lubricate

**TABLE 53-6**  
**Cosmetic Preservatives**

Formaldehyde Releaser	Nonformaldehyde Releaser
Quaternium 15	MCI/MI
Diazolidinyl urea	Parabens
Imidazolidinyl urea	Chloroxylenol
Bromonitropropane	Iodopropynyl butylcarbamate
DMDM hydantoin	Benzalkonium chloride
	Thimerosal

Note: Paraben, quaternium-15 and formaldehyde preservatives are frequently combined and cosensitize.

the active component in a product. They can cause ACD or, in higher concentrations, can act as irritants. Lanolin is a common component of consumer products whose composition has not been fully characterized. Medicaments containing lanolin are more sensitizing than lanolin-containing cosmetics. Lanolin is a weak sensitizer when applied on normal skin but a stronger sensitizer on damaged skin.

Hair products are second only to skin care products as the most common cause of cosmetic allergy. Allergy to routine hair care products is usually due to fragrance and cocoamidopropyl betaine, an amphoteric surfactant often found in shampoos, bath products, eye and facial cleaners, roll-on deodorants and other skin and hair care products. Cocoamidopropyl betaine is less irritating (e.g. baby shampoo) than the older polar surfactants such as sodium lauryl sulfate,<sup>122</sup> but is more allergenic.

New trends in permanent and temporary tattoos have emerged in our adolescent population. Black henna mixtures, containing indigo, henna and PPD and/or diaminotoluens, to temporarily paint the skin are used in some cultures, primarily before major events. There is increasing use of PPD to give henna (auburn to red color) a darker shade of brown to black for body painting, and the need for a policy for use in children has been suggested.<sup>123</sup> Adolescents working in hair salons may be exposed to PPD, the most common allergen affecting hairdressers. A number of chemicals may cross-react with PPD<sup>124</sup> such as PABA in sunscreens, sulfonamides, *p*-aminosalicylic acid, benzocaine and related 'caines' anaesthetics, azo dyes and black rubber mix.

Glycerol thioglycolate, the active ingredient in permanent wave solutions, is a more common cause of occupational ACD in hairdressers than consumers. Unlike PPD, thioglycolates may remain allergenic in the hair long after it has been rinsed out, thus allergic individuals may continue to have skin eruptions weeks after application of the perm, and allergic hairdressers may be unable to cut permanent waved hair.

Nail cosmetics have become increasingly popular and fashionable and ACD to acrylics can present locally at the distal digit or ectopically on the eyelids and face. The currently marketed products contain various methacrylate ester monomers, dimethacrylates and trimethacrylates as well as cyanoacrylate-based glues.

Sunscreens are frequently present in cosmetics such as moisturizers, lip preparations and foundations. As a group they are the most common cause of photoallergic CD. *Chemical-free* sun blocks use physical blocking agents instead of photoactive chemicals and include titanium dioxide and zinc oxide, which are rarely sensitizers.

## CONTACT DERMATITIS IN ATHLETES

The skin of athletes is exposed to repeated trauma, heat, moisture and numerous allergens and chemicals and is predisposed to ICD or ACD. Early recognition can facilitate appropriate therapy and prevention.<sup>125</sup>

In swimmers, chemicals such as chlorine used to disinfect swimming pools can cause both ICD and ACD. The dermatitis may spare the area under the swimwear. However, swimwear and equipment including goggles, nose plugs, nose clips, ear plugs, fins and swim caps may also cause CD. Although ACD from swimming goggles usually presents with well-demarcated, bilateral periorbital edema and erythema with varying degrees of pruritus, exudate and scaling, conjunctival injection and hypopigmentation have been reported.<sup>126,127</sup> Patch testing to rubber products should ideally include a piece of material taken from the suspected goggles. Allergens include rubber and chemicals used in manufacturing (neoprene, benzoyl peroxide, phenol-formaldehyde resin, thioureas and antioxidants).

'Jogger's nipples' are painful, erythematous and crusted erosions representing an ICD caused by friction from the running shirt.<sup>128</sup> Other skin and nail problems are associated with ICD and ACD from shoes, shirts and topical medications. Contact allergens include components of rubber, leather, glues or dyes used in the manufacture of running shoes. Sweat helps leach out the chemicals from the shoes. Rubber insoles containing mercaptobenzothiazole and dibenzothiazyl disulfide have been reported to cause recurrent eczematous eruptions of the feet, which can be prevented by switching to new insoles made of materials such as polyurethane.<sup>129</sup> In a large case series of student athletes, benzocaine and lanolin (found in topical anesthetics and massage creams) were the most prevalent allergens responsible for CD in runners.<sup>130</sup>

CD in soccer or football players is usually caused by equipment or chemicals used on the field. 'Cement burns' presenting as erythematous, edematous plaques, bullae and erosions on the upper inner thighs are due to the lime component used in field markings. The characteristic rash, a history of exposure to wet field lines, and worsening of symptoms after taking a hot shower point to the diagnosis. Treatment includes removing contaminated clothing, cleaning the areas with water and applying topical antibiotics or petroleum jelly.

Like runners, soccer players may develop ACD from topical anesthetic creams, epoxy resins, nickel in certain athletic shoes and tincture of benzoin used in conjunction with athletic tape.<sup>125</sup>

Urea-formaldehyde resin in shin pads has caused ACD in soccer players.

Ball handling in baseball and basketball can cause both ICD and ACD. 'Basketball pebble fingers', manifesting as small petechiae and abrasions on a shiny denuded surface of the fingertips and pads, is an ICD resulting from mechanical irritation from the ball's pebbled surface. An eczematous rash on both palms, the palmar fingertips and base of the thumbs may be due to rubber allergy.<sup>131</sup> Protective knee padding and adhesives in athletic tape contain rubber accelerators and formaldehyde resins.

Tennis players can develop ICD due to friction of the medial thighs. This manifests as erythematous eruptions over the opposing areas. ACD can be caused by isophorone diamine and epoxy resin used in the manufacture of tennis rackets, neoprene splints for tennis elbow, squash balls with



*N*-isopropyl-*N'*-phenylparaphenylenediamine, rubber and anesthetic sprays with ethyl chloride.

Fiberglass in hockey sticks, epoxy resin adhesives in a face mask and dyes used in the manufacture of hockey gloves have caused ACD.<sup>132</sup> Weightlifters have developed ACD to the nickel and palladium in weights or bars<sup>133</sup> and the chalk used to achieve a better grip.<sup>134</sup>

In summary, the young athlete is constantly exposed to allergens in clothing, equipment, environment and medications. The unique presentation of the rash, a careful sports-directed history and allergen-directed patch testing enhances the ability to diagnose and care for the young athlete with dermatitis.

## Treatment and Prevention

Identification of the allergen to improve avoidance of contact to the allergen and education of patients and/or families is the mainstay of treatment for ACD. All other measures are palliative and temporary. Compliance with allergen avoidance is frequently difficult. Once the offending agent is identified, patients and/or caregivers must be educated regarding the nature of the dermatitis, triggering agents and irritant factors. A list of potential exposure alternatives and substitutes should be offered to the patient to increase compliance (see textbooks such as Fisher's *Contact Dermatitis*<sup>135</sup> or Marks et al's *Contact and Occupational Dermatitis*).<sup>136</sup> There are two US databases of products free of allergens the patient is allergic to: the Contact Allergen Management Program (CAMP) of the American Contact Dermatitis Society ([www.contactderm.org](http://www.contactderm.org)) and the Contact Allergen Replacement Database (CARD) of the Mayo Clinic ([www.AllergyFreeSkin.com](http://www.AllergyFreeSkin.com)).

Topical corticosteroids are the first-line treatment for ACD and are most effective when treating localized dermatitis. Low-potency corticosteroids are recommended for the thinner skin of the face and flexural areas, and high-potency corticosteroids are indicated for thickened, lichenified lesions. Ointments are generally more potent, more occlusive and contain fewer sensitizing preservatives than creams and lotions. Patients with sensitivity to preservatives can use preservative-free corticosteroids such as fluocinolone (Synalar<sup>®</sup>) ointment, triamcinolone (Aristocort<sup>®</sup>) ointment or betamethasone dipropionate (Diprosone<sup>®</sup>) ointment. Of note, high-potency corticosteroids should not be used for diaper dermatitis, yet the results of one survey revealed that a combination antifungal-corticosteroid product containing betamethasone dipropionate was used in 6% of encounters.<sup>137</sup>

Cool compresses with aluminum subacetate (Burrow's solution), calamine or colloidal oatmeal may help acute, oozing lesions. Excessive handwashing should be discouraged in patients with hand dermatitis, and nonirritating or sensitizing moisturizers must be used after washing. Soaps and nonalkaline cleansers should be avoided.

For extensive and severe CD, systemic corticosteroids may offer relief within 12 to 24 hours.

Topical calcineurin inhibitors, approved for children with AD, have been used in both animal models and patients with ACD.<sup>138,139</sup> These agents do not induce skin atrophy

and may be especially valuable in treating facial or eyelid dermatitis, although use in CD would be off-label at the present time.

Antihistamines may offer some benefit in contact urticaria and some relief from pruritus. Oral diphenhydramine should not be used in patients with ACD to diphenhydramine in a calamine base (Caladryl<sup>®</sup>) or hydroxyzine hydrochloride (Atarax<sup>®</sup>) in ethylenediamine-sensitive patients. Other treatments include ultraviolet light as well as immunomodulating agents such as methotrexate, azathioprine and mycophenolate mofetil.

Mechanical barriers such as protective gloves and clothing and barrier creams are helpful in some cases. For nickel-allergic patients, barriers such as gloves, covers for metal buttons and identification of nickel by the dimethylglyoxime test can be prescribed but results can be disappointing.<sup>136</sup>

Frequency of diaper changes using improved product design features, such as superabsorbent disposable diapers, is believed to explain the decline in diaper dermatitis among infants.<sup>140</sup> Low-potency corticosteroids and barrier ointments or creams can be used for a limited period of time.<sup>141</sup> A topical antifungal agent should be used in secondary *C. albicans* infection. A gentle cleansing routine, frequent diaper changes and a thick barrier cream help control this condition.<sup>142</sup>

Patient education regarding the nature of the dermatitis, triggering agents and irritant factors plus instruction for avoidance and appropriate substitutes will not only aid in clearing the dermatitis but also prevent or minimize recurrences. At present, hyposensitization of patients with ACD is not a viable therapy.<sup>143</sup>

## Conclusions

Contact dermatitis includes irritant and allergic forms and can affect patients of any age. Identification and avoidance of the allergen is key to the successful treatment of ACD. Patch testing remains the gold standard for diagnosis of ACD even in children, and negative results in the face of a convincing clinical presentation should prompt further evaluation by a specialist in CD. A limited number of interventions effectively prevent or treat ICD and ACD, but well-controlled, outcome-blinded studies, particularly in the area of ACD prevention, are needed.<sup>144</sup> New insights into the immune mechanisms involved may lead to better treatment strategies, including induction of tolerance, especially with difficult-to-avoid allergens.<sup>145</sup>

## Helpful Websites

American Contact Dermatitis Society website includes 'Find a Physician' for patch testing ([www.contactderm.org](http://www.contactderm.org))

The American Academy of Dermatology website ([www.aad.org](http://www.aad.org))

T.R.U.E. TEST<sup>®</sup> website ([www.truetest.com](http://www.truetest.com))

The complete reference list can be found on the companion Expert Consult website at <http://www.expertconsult.inkling.com>.

## KEY REFERENCES

3. De Groot AC. Patch testing: test concentrations and vehicles for 3700 chemicals. 3rd ed. Amsterdam, the Netherlands: Acdegroot Publishing; 2008.
7. Jacob SE, Brod B, Crawford GH. Clinically relevant patch test reactions in children – a United States based study. *Pediatr Dermatol* 2008;25:520–7.
8. Zug KA, McGinley-Smith D, Warshaw EM, Taylor JS, Rietschel RL, Maibach HI, et al. Contact allergy in children referred for patch testing: North American Contact Dermatitis Group data, 2001–2004. *Arch Dermatol* 2008;144:1329–36.
48. Hogeling M, Pratt M. Allergic contact dermatitis in children: the Ottawa hospital patch-testing clinic experience, 1996 to 2006. *Dermatitis* 2008;19:86–9.
49. Belloni Fortina A, Romano I, Peserico A, Eichenfield LF. Contact sensitization in very young children. *J Am Acad Dermatol* 2011;65:772–9.
64. Wentworth AB, Richardson DM, Davis MD. Patch testing with textile allergens: the Mayo Clinic experience. *Dermatitis* 2012;23:269–74.
74. Warshaw EM, Belsito DV, Taylor JS, Sasseville D, DeKoven JG, Zirwas MJ, et al. North American Contact Dermatitis Group Patch Test Results: 2009 to 2010. *Dermatitis* 2013;24:50–9.
83. Worm M, Aberer W, Agathos M, Becker D, Brasch J, Fuchs T, et al. Patch testing in children – recommendations of the German Contact Dermatitis Research Group (DKG). *J Dtsch Dermatol Ges* 2007;5:107–9.
91. Bourke J, Coulson I, English J; British Association of Dermatologists Therapy Guidelines and Audit Subcommittee. Guidelines for the management of contact dermatitis: an update. *Br J Dermatol* 2009;60:946–54.
125. Kockentiet B, Adams BB. Contact dermatitis in athletes. *J Am Acad Dermatol* 2007;56:1048–55.
145. Fonacier L, Bernstein D, Pacheco K, Holness DL, Blessing-Moore J, Khan D, et al. Contact Dermatitis: A Practice Parameter Update – 2015. *J Allergy Clin Immunol Pract* 2015;3:S1–39.

## REFERENCES

- Mortz CG, Andersen KE. Allergic contact dermatitis in children and adolescents. *Contact Dermatitis* 1999;41:121–30.
- Beltrani VS, Beltrani VP. Contact dermatitis. *Ann Allergy Asthma Immunol* 1997;78:160–73, quiz 174–6.
- De Groot AC. Patch testing: test concentrations and vehicles for 3700 chemicals. 3rd ed. Amsterdam, the Netherlands: Acdegroot Publishing; 2008.
- Militello G, Jacob SE, Crawford GH. Allergic contact dermatitis in children. *Curr Opin Pediatr* 2006;18:385–90.
- Weston WL, Weston JA, Kinoshita J, Kloepfer S, Carreon L, Toth S, et al. Prevalence of positive epicutaneous tests among infants, children, and adolescents. *Pediatrics* 1986;78:1070–4.
- Bruckner AL, Weston WL, Morelli JG. Does sensitization to contact allergens begin in infancy? *Pediatrics* 2000;105:e3.
- Jacob SE, Brod B, Crawford GH. Clinically relevant patch test reactions in children – a United States based study. *Pediatr Dermatol* 2008;25:520–7.
- Zug KA, McGinley-Smith D, Warshaw EM, Taylor JS, Rietschel RL, Maibach HI, et al. Contact allergy in children referred for patch testing: North American Contact Dermatitis Group data, 2001–2004. *Arch Dermatol* 2008;144:1329–36.
- Fisher AA. Allergic contact dermatitis in early infancy. *Cutis* 1994;54:300–2.
- Kwangskukstith C, Maibach HI. Effect of age and sex on the induction and elicitation of allergic contact dermatitis. *Contact Dermatitis* 1995;33:289–98.
- Seidenari S, Giusti F, Pepe P, Mantovani L. Contact sensitization in 1094 children undergoing patch testing over a 7 year period. *Pediatr Dermatol* 2005;22:1–5.
- Bruckner AL, Weston WL, Morelli JG. Does sensitization to contact allergens begin in infancy? *Pediatrics* 2000;105:e3.
- Fernandez Vozmediano JM, Armario Hita JC. Allergic contact dermatitis in children. *J Eur Acad Dermatol Venereol* 2005;19:42–6.
- DeLeo VA, Taylor SC, Belsito DV, Fowler JF Jr, Fransway AF, Maibach HI, et al. The effect of race and ethnicity on patch test results. *J Am Acad Dermatol* 2002;46:5107–12.
- Fartasch M, Schnetz E, Diepgen TL. Characterization of detergent-induced barrier alterations: effect of barrier cream on irritation. *J Invest Dermatol Symp Proc* 1998;3:121–7.
- Wood LC, Jackson SM, Elias PM, Grunfeld C, Feingold KR. Cutaneous barrier perturbation stimulates cytokine production in the epidermis of mice. *J Clin Invest* 1992;90:482–7.
- Brasch J, Burgard J, Sterry W. Common pathogenetic pathways in allergic and irritant contact dermatitis. *J Invest Dermatol* 1992;98:166–70.
- Hoefakker S, Caubo M, van't Erve EH, Roggeveen MJ, Boersma WJ, van Joost T, et al. In vivo cytokine profiles in allergic and irritant contact dermatitis. *Contact Dermatitis* 1995;33:258–66.
- Gittler JK, Krueger JG, Guttman-Yassky E. Atopic dermatitis results in intrinsic and immune abnormalities: Implications for contact dermatitis. *J Allergy Clin Immunol* 2013;131:300–13.
- Novak N, Baurecht H, Schäfer T, Rodriguez E, Wagenpfeil S, Klopp N, et al. Loss-of-function mutations in the filaggrin gene and allergic contact sensitization to nickel. *J Invest Dermatol* 2008;128:1430–5.
- Krasteva M, Kehren J, Horand F, Akiba H, Choquet G, Ducluzeau MT, et al. Dual role of dendritic cells in the induction and down-regulation of antigen-specific cutaneous inflammation. *J Immunol* 1998;160:1181–90.
- Grabbe S, Schwarz T. Immunoregulatory mechanisms involved in elicitation of allergic contact hypersensitivity. *Immunol Today* 1998;19:37–44.
- Xu H, DiIulio NA, Fairchild RL. T cell populations primed by hapten sensitization in contact sensitivity are distinguished by polarized patterns of cytokine production: interferon gamma-producing (Tc1) effector CD8+ T cells and interleukin (IL) 4/IL-10-producing (Th2) negative regulatory CD4+ T cells. *J Exp Med* 1996;183:1001–12.
- Kaplan DH, Igyártó BZ, Gaspari AA. Early immune events in the induction of allergic contact dermatitis. *Nat Rev Immunol* 2012;12:114–24.
- Schmidt M, Raghavan B, Müller V, Vogl T, Fejer G, Tchaptchet S, et al. Crucial role for human Toll-like receptor 4 in the development of contact allergy to nickel. *Nat Immunol* 2010;11:814–19.
- Trautmann A, Akdis M, Kleemann D, Altnauer F, Simon HU, Graeve T, et al. T cell-mediated Fas-induced keratinocyte apoptosis plays a key pathogenetic role in eczematous dermatitis. *J Clin Invest* 2000;106:25–35.
- Trautmann A, Akdis M, Schmid-Grendelmeier P, Disch R, Bröcker EB, Blaser K, et al. Targeting keratinocyte apoptosis in the treatment of atopic dermatitis and allergic contact dermatitis. *J Allergy Clin Immunol* 2001;108:839–46.
- Robert C, Kupper TS. Inflammatory skin diseases, T cells, and immune surveillance. *N Engl J Med* 1999;341:1817–28.
- Campbell JJ, Haraldsen G, Pan J, Rottman J, Qin S, Ponath P, et al. The chemokine receptor CCR4 in vascular recognition by cutaneous but not intestinal memory T cells. *Nature* 1999;400:776–80.
- Sallusto F, Mackay CR, Lanzavecchia A. The role of chemokine receptors in primary, effector, and memory immune responses. *Annu Rev Immunol* 2000;18:593–620.
- Albanesi C, Scarponi C, Cavani A, Federici M, Nasorri F, Girolomoni G. Interleukin-17 is produced by both Th1 and Th2 lymphocytes, and modulates interferon gamma- and interleukin-4-induced activation of human keratinocytes. *J Invest Dermatol* 2000;115:81–7.
- Cavani A, Albanesi C, Traidl C, Sebastiani S, Girolomoni G. Effector and regulatory T cells in allergic contact dermatitis. *Trends Immunol* 2001;22:118–20.
- Martin S, Lappin MB, Kohler J, Delattre V, Leicht C, Preckel T, et al. Peptide immunization indicates that CD8+ T cells are the dominant effector cells in trinitrophenyl-specific contact hypersensitivity. *J Invest Dermatol* 2000;115:260–6.
- Budinger L, Neuser N, Totzke U, Merk HF, Hertl M. Preferential usage of TCR-Vbeta17 by peripheral and cutaneous T cells in nickel-induced contact dermatitis. *J Immunol* 2001;167:6038–44.
- Kapsenberg ML, Wierenga EA, Stiekema FE, Tiggeleman AM, Bos JD. Th1 lymphokine production profiles of nickel-specific CD4+ T lymphocyte clones from nickel contact allergic and non-allergic individuals. *J Invest Dermatol* 1992;98:59–63.
- Cavani A, Mei D, Guerra E, Corinti S, Giani M, Pirrotta L, et al. Patients with allergic contact dermatitis to nickel and nonallergic individuals display different nickel-specific T cell responses: evidence for the presence of effector CD8+ and regulatory CD4+ T cells. *J Invest Dermatol* 1998;111:621–8.
- Larsen JM, Bonefeld CM, Poulsen SS. IL-23 and TH17-mediated inflammation in human allergic contact dermatitis. *J Allergy Clin Immunol* 2009;123:486–92.
- Cavani A, Nasorri F, Prezzi C, Sebastiani S, Albanesi C, Girolomoni G. Human CD4+ T lymphocytes with remarkable regulatory functions on dendritic cells and nickel-specific Th1 immune responses. *J Invest Dermatol* 2000;114:295–302.
- Jacob SE, Herro EM. *Practical Patch Testing and Chemical Allergens in Contact Dermatitis*. Lexington: Springer; 2013. p. 13–20, 86, 112, 113.
- McFadden J. Immunologic contact urticaria. *Immunol Allergy Clin North Am* 2014;34:157–67.
- Gimenez-Arnau A, Maurer M, De La Cuadra J, Maibach H. Immediate contact skin reactions, an update of Contact Urticaria, Contact Urticaria Syndrome and Protein Contact Dermatitis – ‘A Never Ending Story’. *Eur J Dermatol* 2010;20:552–62.
- Hjorth N, Roed-Peterson J. Occupational protein contact dermatitis in food handlers. *Contact Dermatitis* 1976;2:28–42.
- Uehara M, Sawai T. A longitudinal study of contact sensitivity in patients with atopic dermatitis. *Arch Dermatol* 1989;125:366–8.
- Lobitz WC Jr, Honeyman JF, Winkler NW. Suppressed cell-mediated immunity in two adults with atopic dermatitis. *Br J Dermatol* 1972;86:317–28.
- Lammintausta K, Kalimo K, Fagerlund VL. Patch test reactions in atopic patients. *Contact Dermatitis* 1992;26:234–40.
- Belhadjali H, Mohamed M M, Youssef M, Mandhouj S, Chakroun M, Zili J. Contact sensitization in atopic dermatitis: results of a prospective study of 9 cases in Tunisia. *Contact Dermatitis* 2008;58:188–9.
- Oranje AP, Bruynzeel DP, Stenveld HJ, Dieges PH. Immediate- and delayed-type contact hypersensitivity in children older than 5 years with atopic dermatitis: a pilot study comparing different tests. *Pediatr Dermatol* 1994;11:209–15.
- Hogeling M, Pratt M. Allergic contact dermatitis in children: the Ottawa hospital patch-testing clinic experience, 1996 to 2006. *Dermatitis* 2008;19:86–9.
- Belloni Fortina A, Romano I, Peserico A, Eichenfield LF. Contact sensitization in very young children. *J Am Acad Dermatol* 2011;65:772–9.
- Jacob SE, Yang A, Herro E, Zhang C. Contact allergens in a pediatric population: association with atopic dermatitis and comparison with other north American referral

- centers. *J Clin Aesthet Dermatol* 2010;3:29–35.
51. Iliiev D, Elsnér P. Clinical irritant contact dermatitis syndromes. *Immunol Allergy Clin North Am* 1997;17:365–75.
  52. Toledo F, Garcia-Bravo B, Fernández-Redondo V, De la Cuadra J, Giménez-Arnau AM, Borrego L, et al. Patch testing in children with hand eczema. A 5-year multicentre study in Spain. *Contact Dermatitis* 2011;65:213–19.
  53. Duarte I, Terumi Nakano J, Lazzarini R. Hand eczema: evaluation of 250 patients. *Am J Contact Dermat* 1998;9:216–23.
  54. Warshaw EM, Ahmed RL, Belsito DV, DeLeo VA, Fowler JF Jr, Maibach HI, et al. Contact dermatitis of the hands: cross-sectional analyses of North American Contact Dermatitis Group Data, 1994–2004. *J Am Acad Dermatol* 2007;57:301–14.
  55. Edman B. Statistical relations between hand eczema and contact allergens. In: Menne T, Maibach HI, editors. *Hand eczema*. 2nd ed. Boca Raton (LA): CRC Press; 2000. p. 75–83.
  56. Warshaw E, Lee G, Storrs FJ. Hand dermatitis: a review of clinical features, therapeutic options, and long-term outcomes. *Dermatitis* 2003;14:119–28.
  57. Ayala F, Fabbrocini G, Bacchilega R, Berardesca E, Caraffini S, Corazza M, et al. Eyelid dermatitis: an evaluation of 447 patients. *Dermatitis* 2003;14:69–74.
  58. Guin JD. Eyelid dermatitis: experience in 203 cases. *J Am Acad Dermatol* 2002;47:755–65.
  59. Rietschel RL, Warshaw EM, Sasseville D, Fowler JF, DeLeo VA, Belsito DV, et al. Common contact allergens associated with eyelid dermatitis: data from the North American Contact Dermatitis Group 2003–2004 Study Period. *Dermatitis* 2007;18:78–81.
  60. Katz AS, Sherertz EF. Facial dermatitis: patch test results and final diagnoses. *Am J Contact Dermat* 1999;10:153–6.
  61. Sainio EL, Kanerva L. Contact allergens in toothpastes and a review of their hypersensitivity. *Contact Dermatitis* 1995;33:100–5.
  62. Torgerson RR, Davis MDP, Bruce AJ, Farmer SA, Rogers RS 3rd. Contact allergy in oral disease. *J Am Acad Dermatol* 2007;57:315–21.
  63. Giusti F, Massone F, Bertoni L, Pellacani G, Seidenari S. Contact sensitization to disperse dyes in children. *Pediatr Dermatol* 2003;20:393–7.
  64. Wentworth AB, Richardson DM, Davis MD. Patch testing with textile allergens: the Mayo Clinic experience. *Dermatitis* 2012;23:269–74.
  65. Ryberg K, Isaksson M, Gruvberger B, Hindsen M, Zimerson E, Bruze M. Contact allergy to textile dyes in southern Sweden. *Contact Dermatitis* 2006;54:313–21.
  66. Jordon WE, Lawson KD, Berg RW, Franxman JJ, Marrer AM. Diaper dermatitis: frequency and severity among a general infant population. *Pediatr Dermatol* 1986;3:198–207.
  67. Bonifazi E. Napkin dermatitis-causative factors. In: Harper J, Oranje A, Prose N, editors. *Textbook of pediatric dermatology*. London: Blackwell Scientific Publications; 2000.
  68. Scheinfeld N. Diaper dermatitis: a review and brief survey of eruptions of the diaper area: therapy in practice. *Am J Clin Dermatol* 2005;6:273–81.
  69. Philipp R, Hughes A, Golding J. Getting to the bottom of nappy rash. ALSPAC Survey Team. *Avon Longitudinal Study of Pregnancy and Childhood*. *Br J Gen Pract* 1997;47:493–7.
  70. Belhadjali H, Giordano-Labadie F, Rance F, Bazex J. ‘Lucky Luke’ contact dermatitis from diapers: a new allergen? *Contact Dermatitis* 2001;44:248.
  71. Reid CM, van Grutten M, Rycroft RJ. Allergic contact dermatitis from ethylbutylthiourea in neoprene. *Contact Dermatitis* 1993;28:193.
  72. Romaguera C, Vilaplana J. Contact dermatitis in children: 6 years experience (1992–1997). *Contact Dermatitis* 1998;39:277–80.
  73. Lazzarini R, Duarte I, Marzagao C. Contact dermatitis of the feet: a study of 53 cases. *Dermatitis* 2004;15:125–30.
  74. Warshaw EM, Belsito DV, Taylor JS, Sasseville D, DeKoven JG, Zirwas MJ, et al. North American Contact Dermatitis Group Patch Test Results: 2009 to 2010. *Dermatitis* 2013;24:50–9.
  75. Zug KA, Rietschel RL, Warshaw EM, Belsito DV, Taylor JS, Maibach HI, et al. The value of patch testing patients with a scattered generalized distribution of dermatitis: retrospective cross-sectional analyses of North American Contact Dermatitis Group data, 2001 to 2004. *J Am Acad Dermatol* 2008;59:426–31.
  76. Hjorth N. Eczematous allergy to balsams, allied perfumes and flavoring agents. Copenhagen: Munksgaard; 1961. p. 134.
  77. Moreno-Ramirez D, Garcia-Bravo B, Pichardo AR, Rubio FP, Martínez FC. Baboon syndrome in childhood: easy to avoid, easy to diagnose, but the problem continues. *Pediatr Dermatol* 2004;21:250–3.
  78. Goossens C, Sass U, Song M. Baboon syndrome. *Dermatology* 1997;194:421–2.
  79. Audicana M, Bernedo N, Gonzalez I, Muñoz D, Fernández E, Gastaminza G. An unusual case of baboon syndrome due to mercury present in a homeopathic medicine. *Contact Dermatitis* 2001;45:185.
  80. Alegre M, Pujol RM, Alomar A. A generalized itchy flexural eruption in a 7-year-old boy. *Arch Dermatol* 2000;136:1055–60.
  81. Bartolome B, Cordoba S, Sanchez-Perez J, Fernandez-Herrera J, Garcia-Diez A. Baboon syndrome of unusual origin. *Contact Dermatitis* 2000;43:113.
  82. Beattie PE, Green C, Lowe G, Lewis-Jones MS. Which children should we patch test? *Clin Exp Dermatol* 2007;32:6–11.
  83. Worm M, Aberer W, Agathos M, Becker D, Brasch J, Fuchs T, et al. Patch testing in children – recommendations of the German Contact Dermatitis Research Group (DKG). *J Dtsch Dermatol Ges* 2007;5:107–9.
  84. Fisher AA. Childhood allergic contact dermatitis. *Cutis* 1975;15:635–42.
  85. Carder KR. Hypersensitivity reactions in neonates and infants. *Dermatol Ther* 2005;18:160–75.
  86. Jacob SE, Burk CJ, Connelly EA. Patch testing: another steroid-sparing agent to consider in children. *Pediatr Dermatol* 2008;25:81–7.
  87. Weston WL, Weston JA, Kinoshita J, Kloepper S, Carreon L, Toth S, et al. Prevalence of positive epicutaneous tests among infants, children, and adolescents. *Pediatrics* 1986;78:1070–4.
  88. Jacob SE, Herro EM, Sullivan K, Matiz C, Eichenfield L, Hamann C. Safety and efficacy evaluation of TRUE TEST panels 1.1, 2.1, and 3.1 in children and adolescents. *Dermatitis* 2011;22:204–10.
  89. Sherertz EF, Fransway AF, Belsito DV, DeLeo VA, Fowler JF Jr, Maibach HI, et al. Patch testing discordance alert: false-negative findings with rubber additives and fragrances. *J Am Acad Dermatol* 2001;45:313–14.
  90. Suneja T, Belsito DV. Comparative study of Finn Chambers and T.R.U.E. test methodologies in detecting the relevant allergens inducing contact dermatitis. *J Am Acad Dermatol* 2001;45:836–9.
  91. Bourke J, Coulson I, English J; British Association of Dermatologists Therapy Guidelines and Audit Subcommittee. Guidelines for the management of contact dermatitis: an update. *Br J Dermatol* 2009;60:946–54.
  92. Bonitiss NG, Tatsioni A, Bassioukas K, Ioannidis JPA. Allergens responsible for allergic contact dermatitis among children: a systematic review and meta-analysis. *Contact Dermatitis* 2011;64:245–7.
  93. Jacob SE, Admani S, Herro EM. Invited Commentary: Recommendation for a North American Pediatric Patch Test Series. *Curr Allergy Asthma Rep* 2014;14:444.
  94. Kornik R, Zug KA. Nickel. *Dermatitis* 2008;19:3–8.
  95. Larsson-Stymne B, Widstrom L. Ear piercing: a cause of nickel allergy in schoolgirls. *Contact Dermatitis* 1985;3:289–93.
  96. Rystedt I, Fischer T. Relationship between nickel and cobalt sensitization in hard metal workers. *Contact Dermatitis* 1983;9:95–200.
  97. Dotterud LK, Falk ES. Metal allergy in north Norwegian schoolchildren and its relationship with ear piercing and atopy. *Contact Dermatitis* 1994;31:308–13.
  98. Kütting B, Brehler R, Traupe H. Allergic contact dermatitis in children: strategies of prevention and risk management. *Eur J Dermatol* 2004;14:80–5.
  99. Rahilly G, Price N. Nickel allergy and orthodontics. *J Orthod* 2003;30:171–4.
  100. Kerosuo H, Kullaa A, Kerosuo E, Kanerva L, Hensten-Petersen A. Nickel allergy in adolescents in relation to orthodontic treatment and piercing of ears. *Am J Orthod Dentofacial Orthop* 1996;109:148–54.
  101. White JM, Goon AT, Jowsey IR, Basketter DA, Mak RK, Kimber I, et al. Oral tolerance to contact allergens: a common occurrence? A review. *Contact Dermatitis* 2007;56:247–54.
  102. Christensen OB, Moller H. Nickel allergy and hand eczema. *Contact Dermatitis* 1975;1:129–35.
  103. Veien NK, Hattel T, Laurberg G. Low nickel diet: an open, prospective trial. *J Am Acad Dermatol* 1993;29:1002–7.
  104. Antico A, Soana R. Chronic allergic-like dermatopathies in nickel sensitive patients: results of dietary restrictions and challenge with nickel salts. *Allergy Asthma Proc* 1999;20:235–42.
  105. Breithaupt A, Jacob SE. Thimerosal and the relevance of patch-test reactions in children. *Dermatitis* 2008;19:275–7.
  106. Goncalo M, Figueiredo A, Goncalo S. Hypersensitivity to thimerosal: the sensitizing moiety. *Contact Dermatitis* 1996;34:201–3.
  107. Marks JG Jr, Belsito DV, DeLeo VA, Fowler JF Jr, Fransway AF, Maibach HI, et al. North American Contact Dermatitis Group patch-test results, 1996–1998. *Arch Dermatol* 2000;136:272–3.
  108. Van’t Veen AJ. Vaccines without thimerosal: why so necessary, why so long coming? *Drugs* 2001;61:565–72.



109. Wantke F, Demmer CM, Götz M, Jarisch R. Contact dermatitis from thimerosal: 2 years' experience with ethylmercuric chloride in patch testing thimerosal-sensitive patients. *Contact Dermatitis* 1994;30:115-17.
110. Suneja T, Belsito D. Thiomersal in the detection of clinically relevant allergic contact reactions. *J Am Acad Dermatol* 2001;45:23-7.
111. Osawa J, Kitamura K, Ikezawa Z, Nakajima H. A probable role for vaccines containing thiomersal in thiomersal hypersensitivity. *Contact Dermatitis* 1991;24:178-82.
112. Centers for Disease Control and Prevention. Thimerosal and 2013-2014 Seasonal Flu Vaccines. CDC, 3 Sep 2013. Web. 12 Dec 2013.
113. Belsito DV. Thimerosal: contact (non)allergen of the year. *Am J Contact Dermat* 2002;13:1-2.
114. Kaaber K, Nielsen AO, Veien NK. Vaccination granulomas and aluminum allergy: course and prognostic factors. *Contact Dermatitis* 1992;26:304-6.
115. Anderson BE. Mixed dialkyl thioureas. *Dermatitis* 2009;20:3-5.
116. Paulsen E, Otkjaer A, Andersen KE. Sesquiterpene lactone dermatitis in the young: is atopy a risk factor? *Contact Dermatitis* 2008;59:1-6.
117. Fortina AB, Romano I, Peserico A. Contact sensitization to compositae mix in children. *J Am Acad Dermatol* 2005;53:877-80.
118. Paulsen E, Andersen KE. Colophonium and Compositae mix as markers of fragrance allergy: cross reactivity between fragrance terpenes, colophonium and compositae plant extracts. *Contact Dermatitis* 2005;53:285-91.
119. Matura M, Goossens A. Contact allergy to corticosteroids. *Allergy* 2000;55:698-704.
120. Gonzalo Garijo MA, Bobadilla Gonzalez P. Cutaneous-mucosal allergic contact reaction due to topical corticosteroids. *Allergy* 1995;50:833-6.
121. Wilkinson SM. Corticosteroids cross reactions: an alternative view. *Contact Dermatitis* 2000;42:59-63.
122. Toxicology EPotACo. Final report on the safety assessment of cocamidopropyl betaine. *J Am Coll Toxicol* 1991;10:33-40.
123. Jacob SE, Zapolski T, Chayavichitsilp P, Connelly EA, Eichenfield LF. p-Phenylenediamine in black henna tattoos: a practice in need of policy in children. *Arch Pediatr Adolesc Med* 2008;162:790-2.
124. De Leo V. p-Phenylenediamine. *Dermatitis* 2006;17:53-5.
125. Kockentiet B, Adams BB. Contact dermatitis in athletes. *J Am Acad Dermatol* 2007;56:1048-55.
126. Goette DK. Raccoon-like periorbital leukoderma from contact with swim goggles. *Contact Dermatitis* 1984;10:129-31.
127. Vaswani SK, Collins DD, Pass CJ. Severe allergic contact eyelid dermatitis caused by swimming goggles. *Ann Allergy Asthma Immunol* 2003;90:672-3.
128. Mailler EA, Adams BB. The wear and tear of 26.2: dermatological injuries reported on marathon day. *Br J Sports Med* 2004;38:498-501.
129. Jung JH, McLaughlin JL, Stannard J, Guin JD. Isolation, via activity-directed fractionation, of mercaptobenzothiazole and dibenzothiazyl disulfide as 2 allergens responsible for tennis shoe dermatitis. *Contact Dermatitis* 1988;19:254-9.
130. Ventura MT, Dagnello M, Matino MG, Di Corato R, Giuliano G, Tursi A. Contact dermatitis in students practicing sports: incidence of rubber sensitization. *Br J Sports Med* 2001;35:100-2.
131. Rodriguez-Serna M, Molinero J, Febrer I, Aliaga A. Persistent hand eczema in a child. *Am J Contact Dermat* 2002;13:35-6.
132. Helm TN, Bergfeld WF. Sports dermatology. *Clin Dermatol* 1998;16:159-65.
133. Guerra L, Misciali C, Borrello P, Melino M. Sensitization to palladium. *Contact Dermatitis* 1988;19:306-7.
134. Scott MJ Jr, Scott NI, Scott LM. Dermatologic stigmata in sports: weightlifting. *Cutis* 1992;50:141-5.
135. Reitschel RL, Fowler JF, Fisher AA, editors. *Fisher's Contact Dermatitis*. Ontario: Hamilton; 2008.
136. Marks JG Jr, Elsner P, DeLeo VA. *Contact and occupational dermatology*. 3rd ed. St Louis: Mosby Inc; 2002.
137. Ward DB, Fleischer AB Jr, Feldman SR, Krowchuk DP. Characterization of diaper dermatitis in the United States. *Arch Pediatr Adolesc Med* 2000;154:943-6.
138. Queille-Roussel C, Graeber M, Thurston M, Lachapelle JM, Decroix J, de Cuyper C, et al. SDZ ASM 981 is the first non-steroid that suppresses established nickel contact dermatitis elicited by allergen challenge. *Contact Dermatitis* 2000;42:349-50.
139. Gupta AK, Adamiak A, Chow M. Tacrolimus: a review of its use for the management of dermatoses. *J Eur Acad Dermatol Venereol* 2002;16:100-14.
140. Runeman B. Skin interaction with absorbent hygiene products. *Clin Dermatol* 2008;26:45-51.
141. Atherton DJ. A review of the pathophysiology, prevention and treatment of irritant diaper dermatitis. *Curr Med Res Opin* 2004;20:645-9.
142. Shin HT. Diaper dermatitis that does not quit. *Dermatol Ther* 2005;18:124-35.
143. Marks JG Jr, Trautlein JJ, Epstein WL, Laws DM, Sicard GR. Oral hyposensitization to poison ivy and poison oak. *Arch Dermatol* 1987;123:476-8.
144. Saary J, Qureshi R, Palda V, DeKoven J, Pratt M, Skotnicki-Grant S, et al. A systematic review of contact dermatitis treatment and prevention. *J Am Acad Dermatol* 2005;53:845.
145. Fonacier L, Bernstein D, Pacheco K, Holness DL, Blessing-Moore J, Khan D, et al. *Contact Dermatitis: A Practice Parameter Update - 2015*. *J Allergy Clin Immunol Pract* 2015;3:S1-39.

# Allergic and Immunologic Eye Disease

LEONARD BIELORY | BRETT P. BIELORY | RUDOLPH S. WAGNER

## KEY POINTS

- The hallmark of allergic conjunctivitis is itching. Bacterial and viral conjunctivitis do not commonly present with pruritus.
- Bacterial and viral conjunctivitis generally have a self-limited course ranging from 5 to 14 days. Signs and symptoms of acute allergic conjunctivitis wax and wane over longer periods of time coinciding with the circulating allergen (e.g. seasonal pollens).
- Chronic conjunctival vascular injection, 'red or pink eye', may occur in children with dry eye disease related to intense viewing of cell phones and other electronic devices.
- Disorders of the tear film as in meibomian gland disease (MGD) can result in chronic blepharoconjunctivitis.
- Topical steroids should be used with caution in treating conjunctivitis in children because they may raise the intraocular pressure (glaucoma) or exacerbate a herpes simplex virus (HSV) keratoconjunctivitis.
- Some systemic antihistamines may produce dry eye symptoms that confound the diagnosis of allergic conjunctivitis.

Allergic disease affects as many as 25% of the pediatric population. The direct costs of upper airway allergies are approximately \$5.9 billion, with children < 12 years accounting for 38% (\$2.3 billion) of the total.<sup>1</sup> In a study of 5,000 allergic children, ocular allergy was reported in 32% as the single manifestation of their allergies.<sup>2</sup> In the USA ocular allergy symptoms have doubled over the past 25 years with up to 40% of the population reporting ocular symptoms in the NHANES study,<sup>3</sup> coinciding with the international market growth in the treatment of anterior ocular inflammatory disorders with anti-allergics occupying 25% of the market.<sup>4</sup> This chapter provides an overview of pediatric 'red eye' eye disease and a focus on the approach to proper diagnosis and management of allergic disorders.

## Eye Anatomy, Histology and Immune Function

The eye is a common target of local and systemic inflammatory disorders that impact on the patient's quality of life, due to its considerable vascularization and vessel sensitivity, and the potential for visual loss. Anterior ocular inflammatory disorder

can pose a formidable diagnostic challenge to clinicians, and thus a solid understanding of the eye's anatomy, histology and immune function is essential.

The eye is essentially constructed of two immunologically active portions (Figure 54-1):

1. Anteriorly the eyelids, conjunctiva (palpebral and bulbar) and tear fluid layer provide the primary barrier against environmental aeroallergens, chemicals and infectious agents and are contiguous with the collagenous sclera, involved in autoimmune disorders.
2. Internally the highly vascular uvea is involved in immune complexes and cell-mediated systemic inflammatory disorders and is contiguous with the retina, which is an extension of the central nervous system.

Immunologic hypersensitivity reactions involving the eye incorporate the spectrum of the classic Gell and Coombs classification<sup>5</sup> (Table 54-1).

## EYELIDS

The eyelids are the first line of defense for the eye as they provide a mechanical barrier that maintains moisture and cleanses the anterior ocular surface. However, the palpebral skin is extremely thin compared to the dermis elsewhere (0.55 mm thick compared to the 2 mm integument of the face), and is also commonly involved in fluid retention, such as in periorbital edema and anasarca.

## CONJUNCTIVA

The conjunctiva is an active immunologic tissue as it consists of a thin mucous membrane that extends from the eyelid margin to the limbus of the eye. It is divided into: (1) the palpebral conjunctiva lining the inner surface of the eyelids; (2) the bulbar conjunctiva covering the sclera; and (3) the fornix or conjunctival sac at the junction between the bulbar and palpebral conjunctiva. The conjunctiva consists of two distinct histologic layers: the epithelium composed of two to five layers of stratified columnar cells, with interspersed mucin producing goblet cells and the substantia propria composed of connective tissue.

Inflammatory cells such as mast cells, eosinophils and basophils normally do not reside in the ocular epithelium. In the substantia propria, mast cells (~6,000/mm<sup>3</sup>) are present, predominantly (>95%) of connective tissue type (MC<sub>TC</sub>).<sup>6-8</sup> However, in the more chronic forms of allergic conjunctivitis, an increase in mucosal type mast cells (MC<sub>T</sub>) can be found in the epithelial layer.<sup>7</sup> Epithelial cells have also been found to have an extensive proinflammatory capability in the production of various cytokines, such as tumor necrosis factor alpha (TNF- $\alpha$ ),

interleukin (IL)-6 and IL-10 as well as various adhesion molecules, such as intracellular adhesion molecules (ICAM-1).

Various mononuclear cells, including Langerhans cells, CD3<sup>+</sup> lymphocytes and CD4<sup>+</sup>/CD8<sup>+</sup> lymphocytes, are also an active component of the anterior surface immune response and are primarily found in the epithelial layer. Langerhans cells, which serve as antigen-presenting cells in the skin, have a similar role in the eye.<sup>6</sup> The primary lymphoid organ for intraocular reactions is the spleen. Although lymphatics do drain from the lateral conjunctiva to the preauricular nodes (e.g. parotid node) just anterior to the tragus of the ear, the nasal conjunctival lymphatics drain to the submandibular nodes. It is generally believed that activated conjunctival lymphocytes travel first to these regional lymph nodes, then to the spleen, and ultimately back to the conjunctiva.

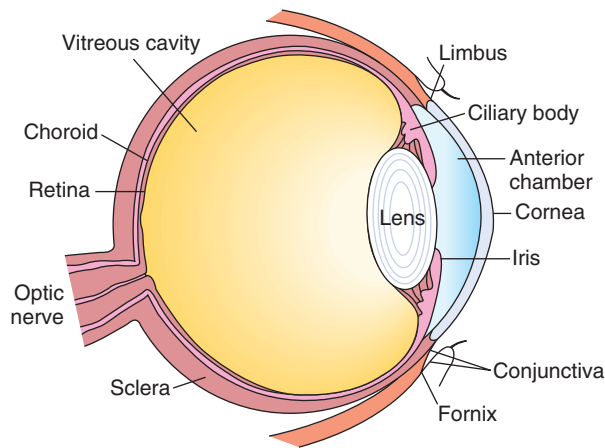

**Figure 54-1** Sagittal cross-sectional view of the human eye revealing the parts commonly involved in immunologic reactions: eyelids (blepharitis and dermatitis); conjunctiva (conjunctivitis); cornea (keratitis); sclera (episcleritis and scleritis); optic nerve (neuritis); iris (iritis); vitreous (vitritis); choroid (choroiditis); and retina (retinitis). The last four parts constitute the inner portion of the eye (the uveal tract) and are classified as forms of uveitis.

## TEAR FILM

The conjunctival surface is bathed in a thin layer of tear film that appears approximately 2 to 4 weeks after birth. A recent model of tear film structure describes an aqueous layer with a gradient of mucin that decreases from the ocular surface to the overlying lipid layer.<sup>9</sup> Goblet cells distributed along the conjunctival surface produce this mucin, which decreases the surface tension of the tear film, thus maintaining a moist hydrophobic corneal surface. The outermost lipid component of the tear film decreases the evaporation rate of the aqueous tears. The aqueous portion of the tear film contains a variety of solutes, including electrolytes, carbohydrates, ureas, amino acids, lipids, enzymes and tear-specific prealbumin, and immunologically active proteins, including immunoglobulin A (IgA), IgG, IgM, IgE, trypsin, histamine, lysozyme, lactoferrin, ceruloplasmin, vitronectin and cytokines.

## UVEAL TRACT

The uveal tract comprises the iris, ciliary body and choroid, each of which possesses a rich vascular architecture and pigment. The pigment acts as a filtering system. The ciliary body is involved in the production of aqueous humor and is a common site for the deposition of immune complexes. In addition, disturbances in the production or outflow of aqueous humor may lead to increased intraocular pressure (IOP; i.e. glaucoma). There are congenital forms of glaucoma that are not specifically associated with immunologic disorders but must be considered in the differential diagnosis of pediatric conjunctivitis ('pink eye' or 'red eye').

## Differential Diagnosis

The differential diagnosis of the pediatric red eye can be broadly divided into four categories: allergic, infectious, immunologic and nonspecific (Figure 54-2). Each category possesses distinct signs and symptoms.<sup>10</sup> These indicators are summarized in Table 54-2 and can be used as a guide to delineate pediatric red eye.

**TABLE 54-1** Categories of Pediatric Ocular Inflammation

Category	Recognition Component	Soluble Mediators	Time Course	Cellular Response	Clinical Example
IgE/mast cell	IgE	Leukotrienes Arachidonates Histamine	Seconds Minutes	Eosinophils Neutrophils Basophils	Allergic conjunctivitis Anaphylaxis Vernal keratoconjunctivitis
Cytotoxic antibody	IgG IgM	Complement	Hours Days	Neutrophils Macrophages	Mooren's ulcer Pemphigus Pemphigoid
Immune complex	IgG IgM	Complement	Hours Days	Neutrophils Eosinophils Lymphocytes	Serum sickness uveitis Corneal immune rings Lens-induced uveitis Behçet's syndrome Kawasaki's disease Vasculitis
Delayed hypersensitivity	Lymphocytes Monocytes	Lymphokines Monokines	Days Weeks	Lymphocytes Monocytes Eosinophils Basophils	Corneal allograft rejection Sympathetic ophthalmia Sarcoid-induced uveitis

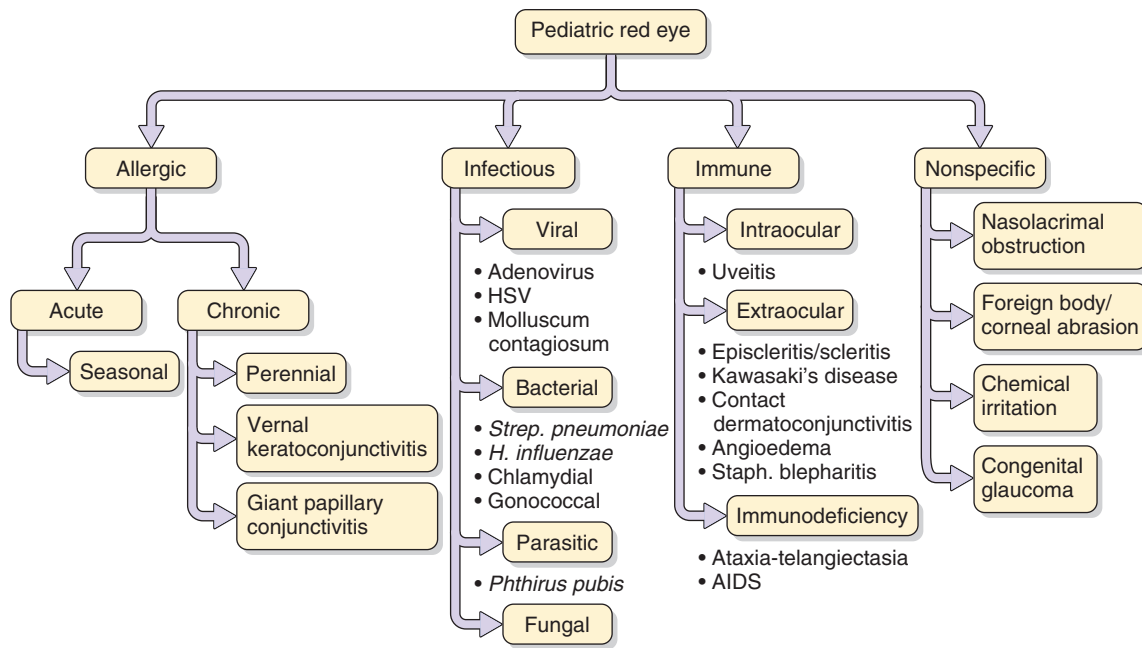

**Figure 54-2** The differential diagnosis of pediatric 'red eye' includes infectious agents (e.g. chlamydial disease, adenovirus), allergic conditions (e.g. SAC, PAC, GPC, VKC), immunologic disorders (e.g. Kawasaki's disease, uveitis, ataxia-telangiectasia) and nonspecific causes (e.g. foreign body, chemical irritation, nasolacrimal obstruction).

## History

A detailed and accurate history is the most important element in distinguishing allergic from nonallergic causes of pediatric conjunctivitis. When evaluating a newborn, a full prenatal history, including developmental delays and maternal infections (e.g. HSV, *Chlamydia* or human immunodeficiency virus [HIV]), needs to be obtained. Ocular trauma from forceps or vacuum delivery has been known to occur. In addition, ocular medications such as silver nitrate and erythromycin given at childbirth may cause chemical irritation. In the older child, recent exposure to individuals with conjunctivitis or upper respiratory tract infection, either within the family or at school, may suggest exposure to adenovirus infection in an endemic area. The conjunctivitis-otitis media syndrome, occurring frequently in preschool children, is usually caused by nontypable *Haemophilus influenzae* or *Streptococcus pneumoniae*.<sup>11,12</sup> Family history is particularly important when inherited disorders are suspected. Accidental trauma resulting in corneal abrasions or ocular foreign bodies may also occur, especially in the curious and mobile toddler. Yet, while accidents occur frequently, child abuse must also be considered; in these circumstances a thorough social history is merited. In teenagers, a sexual history may suggest a chlamydial or neisserial infection. Patient use and abuse of over-the-counter topical medications (e.g. vasoconstrictors, artificial tears, cosmetics or contact lens wear) has the potential to produce inflammation (conjunctivitis medicamentosa or toxic keratopathy). As with all allergies, environmental factors and time of onset must be addressed, including seasonal variation and exposure to tobacco smoke, cleaning supplies, pets, air-conditioning, carpets and other sources of irritants.

Many of the signs and symptoms of allergic conjunctivitis are nonspecific as they involve the four classical signs of inflammation (calor, dolor, rubor and tumor), originally recorded by the Roman encyclopedist Celsus in the 1st century AD, and

include heat, pain, redness, swelling, tearing, irritation, stinging, burning and photophobia. The hallmark of allergic conjunctivitis is itching. Pruritus can be mild or prominent and may last from hours to days. A stringy or ropy discharge is also characteristic of a persistent ocular allergy, and may range from serous to purulent. While a purulent discharge may be present, morning crusting and difficulty opening the lids are more characteristic of bacterial causes, especially Gram-negative organisms (e.g. *Neisseria* and *Haemophilus*). Environmental allergens affect both eyes at once, although a unilateral reaction may result if one eye is inoculated with animal hair or dander. Ocular pain is not typically associated with allergic conjunctivitis and suggests an extraocular process such as a corneal abrasion, scleritis or foreign body, or an intraocular process such as uveitis.

## Eye Examination

The eye should be carefully examined for evidence of eyelid involvement such as blepharitis, dermatitis, swelling, discoloration, ptosis or blepharospasm (Table 54-3). Conjunctival involvement may present with chemosis, hyperemia, cicatrization or formation of papillae on the palpebral and bulbar membranes. The presence of increased or abnormal secretions should also be noted. A fundoscopic examination should be performed to detect such conditions as uveitis (often associated with autoimmune disorders) and cataracts (associated with atopic disorders and chronic steroid use).

The examination starts with an inspection of the face and area surrounding the eye. A horizontal skin crease on the nose (nasal salute) suggests a history of allergic rhinitis. Allergic shiners are ecchymotic-looking areas beneath the eyes thought to result from impaired venous return from the subcutaneous tissues (Figure 54-3). Angioedema commonly involves the conjunctiva, but it more commonly affects the periorbital space and is more prominent around the lower lids secondary to gravity.



**TABLE 54-2**  
**Differential Diagnosis of Pediatric Conjunctivitis**

	Predominant Cell Type	Chemosis	Lymph Node	Cobblestoning	Discharge	Lid Involvement	Pruritus	Gritty Sensation	Pain	Seasonal Variation
<b>ALLERGIC</b>										
AC	Mast cell EOS	+	-	-	Clear mucoid	-	+	+/-	-	+
VKC	Lymph EOS	+/-	-	++	Stringy mucoid	+	++	+/-	+/- if cornea is involved	+
GPC	Lymph EOS	+/-	-	++	Clear white	-	++	+	-	+/-
<b>INFECTIOUS</b>										
Bacterial: Strep., Staph., <i>Haemophilus</i>	PMN	+/-	+	-	++ Mucopurulent	-	-	+	+/-	+/-
Viral	PMN Monolymph	+/-	++	+/-	Clear mucoid	-	-	+	+/-	+/-
Chlamydial	Monolymph	+/-	+/-	+	++ Mucopurulent	-	-	+	+/-	+/-
<b>IMMUNOLOGIC</b>										
Kawasaki's disease	PMN, lymph	+/-	++	-	Serous mucoid	-	-	+/-	+/-	-
Uveitis	Lymph	-	-	-	-	-	-	-	++	-
Sarcoidosis	Lymph	-	-	-	-	Grey flat papules	-	-	+/-	-
JIA	Lymph	-	-	-	-	-	-	-	+/-	-
Episcleritis	Lymph	-	-	-	-	-	-	-	++	-
Contact dermatitis	Lymph	-	-	-	+/-	++	+	-	+/- if cornea is involved	-
Angioedema	Mast cell	++	-	-	-	+++	+/-	-	-	-
Ataxia-telangiectasia	-	-	-	-	-	-	-	-	-	-
Staphylococcal blepharitis	Monolymph	+/-	-	-	++ mucopurulent	++	+	++	+/- if cornea is involved	-
<b>NONSPECIFIC</b>										
Congenital entropion epiblepharon	-	-	-	-	Serous watery	++	-	+	+++	-
Congenital glaucoma	-	-	-	-	Serous	+/-	-	+/-	+++	-
Corneal abrasion	-	-	-	-	Serous watery	+	-	+/-	+++	-
Chemical	-	-	-	-	Serous mucoid	++	-	+/-	+++	-
Nasolacrimal obstruction	PMN if secondary infection	-	-	-	Mucopurulent	+	-	+/-	+/-	-

AC – Allergic conjunctivitis, EOS – eosinophils, VKC – vernal keratoconjunctivitis, GPC – giant papillary conjunctivitis, PMN – polymorphonuclear leukocytes, JIA – juvenile idiopathic arthritis.

**TABLE 54-3** Ocular Clinical Signs

Disorder	Description
Blepharitis	Inflammation of the eyelids; sometimes associated with the loss of eyelashes (madarosis)
Chalazion	A chronic, granulomatous inflammation of the meibomian gland
Chemosis	Edema of the conjunctiva due to transudate leaking through fenestrated conjunctival capillaries
Epiphora	Excessive tearing; may be due to increased tear production or more commonly congenital obstruction of the nasolacrimal drainage system. This may occur in as many as 20% of infants, but resolves spontaneously in most cases before 1 year of age. <sup>13</sup> Children with chronic sinusitis and/or rhinitis may have intermittent nasolacrimal duct obstruction since the distal nasolacrimal duct drains below the inferior meatus. Congenital glaucoma may also present with epiphora but has other characteristic findings (e.g. corneal enlargement, photophobia and eventually corneal edema presenting as a corneal haze) usually within the first year of life*
Hordeolum	Synonymous with a styne
Keratitis	Inflammation and infection of the corneal surface, stroma and endothelium, with numerous causes
Leukocoria	A white pupil; seen in patients with Chédiak-Higashi syndrome (a neutrophil defect), retinoblastoma, cataracts and retrolental fibroplasia
Papillae	Large, hard, polygonal, flat-topped excrescences of the conjunctiva seen in many inflammatory and allergic ocular conditions
Phlyctenule	The formation of a small, gray, circumscribed lesion at the corneal limbus that has been associated with staphylococcal sensitivity, tuberculosis and malnutrition
Proptosis	Forward protrusion of the eye or eyes
Ptosis	Drooping of the eyelid, which may have neurogenic, muscular or congenital causes. Conditions specific to the eyelid that may cause a ptotic lid include chalazia, tumors and preseptal cellulitis
Scleritis	Inflammation of the tunic that surrounds the ocular globe. Episcleritis presents as a red, somewhat painful eye in which the inflammatory reaction is located below the conjunctiva and only over the globe of the eye. The presence of scleritis should prompt a search for other systemic immune-mediated disorders
Trichiasis	In-turned eyelashes; usually results from the softening of the tarsal plate within the eyelid
Trantas' dots	Pale, grayish-red, uneven nodules made up of eosinophils with a gelatinous composition seen at the limbal conjunctiva in vernal conjunctivitis

\*Data from Seidman DJ, Nelson LB, Calhoun JH, et al. *Pediatrics* 1986;77:399-404.

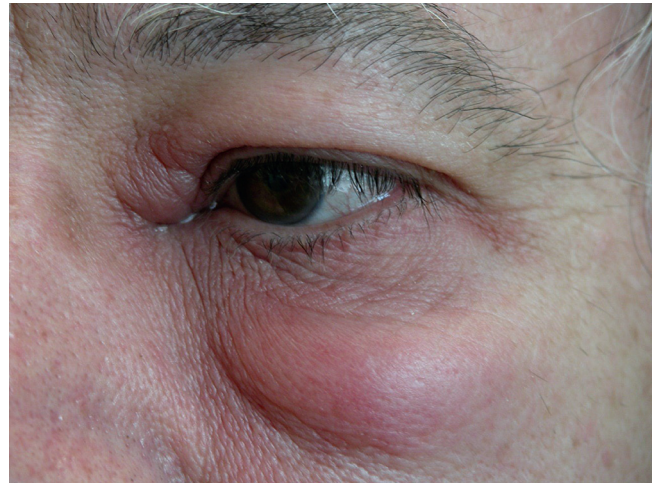

**Figure 54-3** Patient with periorbital swelling.

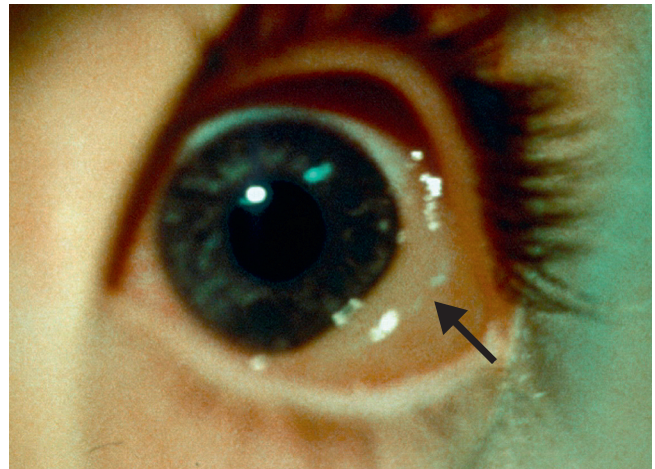

**Figure 54-4** Conjunctival edema or chemosis with milky appearance obscuring conjunctival vessels in an acute allergic reaction.

Eyelid or nasal vesicular eruptions are often seen in ophthalmic zoster, but can also reflect recurrent bacterial infection-associated staphylococcal blepharoconjunctivitis due to constant rubbing of the eyelids. Scratches and scars on the face or eyelid suggest ocular injury. In addition, palpation of the sinuses and the preauricular and cervical chain lymph nodes is of diagnostic importance.

Next, the conjunctiva should be thoroughly inspected. The bulbar conjunctiva examination is performed by looking directly at the eye and asking the patient to look up and then down, while gently retracting the opposite lid. Examine the palpebral (tarsal) conjunctiva by grasping the upper lid at its base with a cotton swab on the superior portion of the lid while gently pulling the lid out and up as the patient looks down. To return the lid to its normal position, have the patient look up. The lower tarsal conjunctiva is examined by placing a finger near the lid margins, everting the lower eyelid and drawing downward. A 'milky' appearance of the conjunctiva is characteristic of allergy and is the result of the obscuring of blood vessels by conjunctival edema (Figure 54-4). In contrast, a velvety, beefy-red conjunctiva with purulent discharge suggests a viral or bacterial etiology, while follicular or papillary

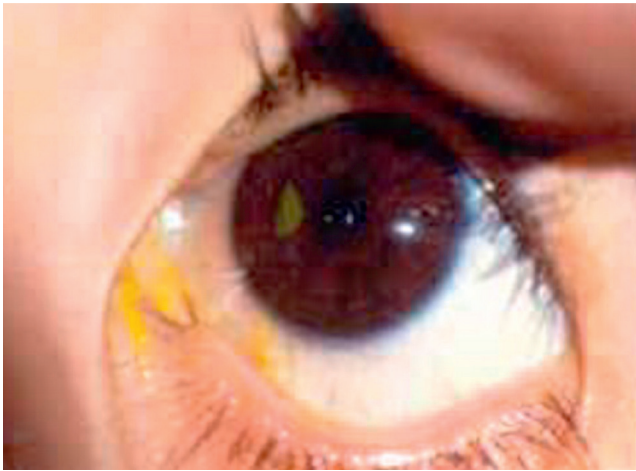
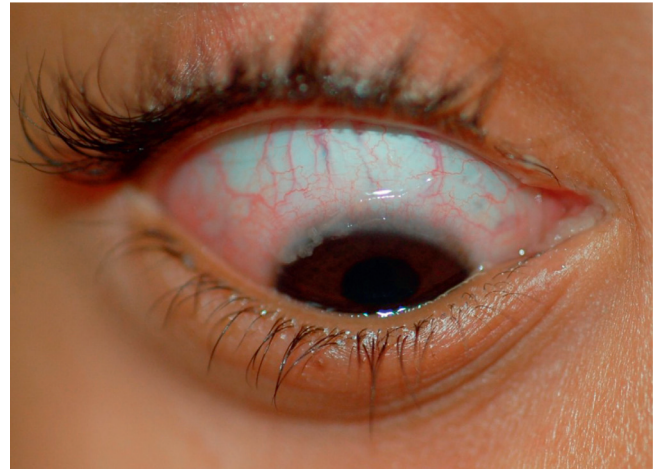

**Figure 54-5** Triangular corneal abrasion highlighted with fluorescein dye.

hyperplasia of the conjunctival surface reflects a more persistent or chronic inflammatory condition. Follicles appear as grayish, clear or yellow bumps varying in diameter from a pinpoint to 2 mm, with conjunctival vessels on their surface, while papillae contain a centrally located tuft of vessels. Although a fine papillary reaction is nonspecific, giant papillae (greater than 1 mm) on the upper tarsal conjunctiva indicate an allergic source. Papillae are generally not seen in active viral or bacterial conjunctivitis. The presence of follicles, a lymphocytic response in the conjunctiva, is a specific finding that occurs primarily in viral and chlamydial infections, but is also seen in chronic and persistent forms of ocular allergy.

The cornea is best examined with a slit lamp biomicroscope, although many important clinical features can be seen with the naked eye or with the use of an ophthalmoscope. The cornea should be perfectly smooth and transparent. Dusting of the cornea may indicate punctate epithelial keratitis. A localized corneal defect may suggest erosion or a larger ulcer that could be related to major basic protein deposition. Surface lesions can best be demonstrated by applying fluorescein dye to the eye, preferably following the instillation of a topical anesthetic drop (Figure 54-5). The end of the fluorescein strip is touched to the marginal tear meniscus. When the patient blinks, the dye is dispersed throughout the ocular surface and stains wherever an epithelial defect exists, as in a corneal or conjunctival abrasion. A light utilizing a cobalt filter, found on most modern ophthalmoscopes, will best demonstrate abnormal accumulations of the dye. Mucus adhering to the corneal or conjunctival surfaces is considered pathologic.

The limbus is the zone immediately surrounding the cornea that becomes intensely inflamed with a deep pink coloration in cases of anterior uveitis or iritis, the so-called 'ciliary flush'. Discrete swellings with small white dots are indicative of degenerating cellular debris, which is commonly seen in vernal conjunctivitis (Figure 54-6). The anterior chamber is examined for clearness or cloudiness of the aqueous humor and for the presence of blood, either diffuse or settled out (i.e. hyphema) or the settling out of pus (i.e. hypopyon). A shallow anterior chamber suggests narrow-angle glaucoma and is a contraindication for the use of mydriatic agents. An estimation of the anterior chamber depth can be made by illuminating it from the side with a pen light; if the iris creates a shadow on the far side from



**Figure 54-6** Limbal conjunctivitis (a form of vernal conjunctivitis).

the light, then there is a high index of suspicion for increased IOP (i.e. glaucoma).

## Allergic Disorders

Conjunctivitis caused by IgE-mast cell-mediated reactions is the most common hypersensitivity response of the eye. Direct exposure of the ocular mucosal surface to the environment stimulates these mast cells, clinically producing the acute- and late-phase signs and symptoms of allergic conjunctivitis.<sup>14,15</sup> In addition, the conjunctiva is infiltrated with inflammatory cells such as neutrophils, eosinophils, lymphocytes and macrophages. Interestingly, acute forms of allergic conjunctivitis lack an eosinophilic predominance, as seen in asthma. However, eosinophils and other immunologically active cells are prevalent in the more chronic forms.

### SEASONAL ALLERGIC CONJUNCTIVITIS

Seasonal allergic conjunctivitis (SAC) is the most common allergic conjunctivitis, representing over half of all cases. As its name implies, SAC is characterized by symptoms that are seasonal and related to specific aeroallergens. Symptoms predominate in the spring and in some areas during the fall (Indian summer). Grass pollen is thought to produce the most ocular symptoms. Patients report itchy eyes and/or a burning sensation with watery discharge, commonly associated with nasal or pharyngeal symptoms. A white exudate may be present that turns stringy in the chronic form of the condition. The conjunctiva appears milky or pale pink and is accompanied by vascular congestion that may progress to conjunctival swelling (chemosis). Symptoms are usually bilateral but not always symmetric in degree of involvement. SAC rarely results in permanent visual impairment but can interfere greatly with daily activities.

### PERENNIAL ALLERGIC CONJUNCTIVITIS

Perennial allergic conjunctivitis (PAC) is considered a variant of SAC that persists throughout the year. Dust mites, animal dander and feathers are the most common allergens. Symptoms are analogous to those of SAC, and 79% of PAC patients have



seasonal exacerbations. In addition, both PAC and SAC are similar in distribution of age, sex and associated symptoms of asthma or eczema. The prevalence of PAC has been reported to be lower than that of SAC (3.5:10,000) although it is subjectively more severe,<sup>16</sup> but with the increasing prevalence of allergies as reported in the International Study of Asthma and Allergies in Childhood this may be underrepresented; in fact, perennial forms of ocular allergy may be more common than pure seasonal forms.

### VERNAL KERATOCONJUNCTIVITIS

Vernal keratoconjunctivitis (VKC) is a severe, bilateral, recurrent, chronic inflammatory process of the upper tarsal conjunctival surface. It has a marked seasonal incidence, and its frequent onset in the spring has led to use of the term 'vernal catarrh'. It occurs most frequently in children and young adults who have a history of seasonal allergy, asthma and eczema. The age of onset for VKC is usually before puberty, with boys being affected twice as often as girls. After puberty it becomes equally distributed between the sexes and 'burns out' by the third decade of life (about 4 to 10 years after onset). VKC may threaten sight if the cornea is involved and is more common in persons of Asian or African origin.

Symptoms of VKC include intense pruritus exacerbated by time and exposure to wind, dust, bright light, hot weather or physical exertion associated with sweating. Associated symptoms involving the cornea include photophobia, foreign body sensation and lacrimation. Signs include: conjunctival hyperemia with papillary hypertrophy ('cobblestoning') reaching 7 to 8 mm in diameter in the upper tarsal plate; a thin, copious milk-white fibrinous secretion composed of eosinophils, epithelial cells and Charcot-Leyden granules; limbal or conjunctival 'yellowish-white points' (Horner's points and Trantas' dots) lasting 2 to 7 days; an extra lower eyelid crease (Dennie's line); corneal ulcers infiltrated with Charcot-Leyden crystals; or pseudomembrane formation of the upper lid when everted and exposed to heat (Maxwell-Lyon's sign; Figure 54-7). Although VKC is a bilateral disease, it may affect one eye more than the other.

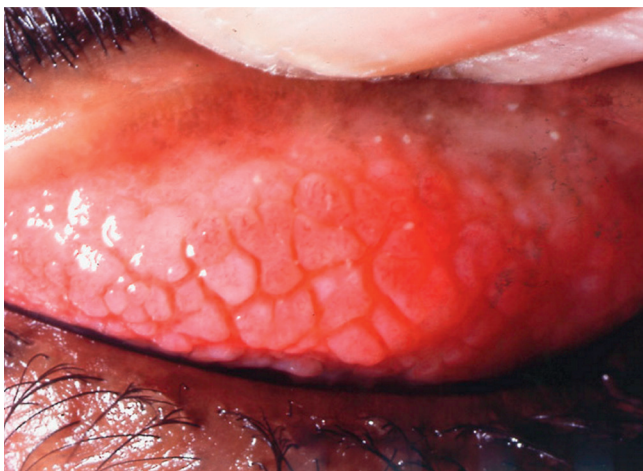

**Figure 54-7** Conjunctival hyperemia with papillary hypertrophy (cobblestoning) on the everted palpebral conjunctiva of the upper eyelid in a patient with vernal conjunctivitis.

VKC is characterized by conjunctival infiltration by eosinophils, degranulated mast cells, basophils, plasma cells, lymphocytes and macrophages. Degranulated eosinophils and their toxic enzymes (e.g. major basic proteins) have been found in the conjunctiva and in the periphery of corneal ulcers, a fact that may suggest their etiopathogenic role in many of the problems associated with VKC.<sup>15,16</sup> MC<sub>T</sub> cells are increased in the conjunctiva of these patients.<sup>8</sup> Tears from VKC patients have been found to contain higher levels of leukotrienes and histamine (16 ng/mL) when compared to controls (5 ng/mL).<sup>17</sup> Tears from VKC patients also contain major basic protein, Charcot-Leyden crystals, basophils, IgE and IgG specific for aeroallergens (e.g. ragweed pollen) and eosinophils (in 90% of cases).<sup>18</sup> The tear-specific IgE does not correlate with the positive immediate skin tests that VKC patients may have, thus it represents more than a chronic allergic response as reflected in a study that suggested that exposure to house dust mite allergen aggravates VKC symptoms.<sup>19</sup>

### GIANT PAPILLARY CONJUNCTIVITIS

Giant papillary conjunctivitis (GPC) is associated with the infiltration of basophils, eosinophils, plasma cells and lymphocytes. GPC has been directly linked to the continued use of contact lenses with a seasonal increase of symptoms during the spring pollen season, including itching. Signs include a white or clear exudate upon awakening that chronically becomes thick and stringy. Patients may develop Trantas' dots, limbal infiltration and bulbar conjunctival hyperemia and edema. Upper tarsal papillary hypertrophy ('cobblestoning') has been described in 5% to 10% of soft and 3% to 4% of hard contact lens wearers. The contact lens polymer, the preservative (thimerosal) and proteinaceous deposits on the surface of the lens have been implicated in GPC, but this remains controversial. Analysis of the glycoprotein deposits on disposable soft contact lenses has revealed that the higher the water content, the higher the protein integration (lysozyme, tear-specific prealbumin and the heavy chain components of IgG) into the lens.<sup>20</sup>

## Immunologic Disorders

### KAWASAKI'S DISEASE

Kawasaki's disease (KD) (*mucocutaneous lymph node syndrome*) is the most common systemic vasculitis after Henoch-Schönlein purpura and the most common cause of acquired heart disease in the pediatric population. KD is an acute exanthematous illness that almost exclusively affects children: 50% of cases occurring in males less than 2 years of age, with an increased prevalence in individuals of Japanese ancestry. Five of the following six criteria must be present for diagnosis: (1) fever, (2) bilateral conjunctival injection, (3) changes in upper respiratory tract mucous membrane, (4) changes in skin and nails, (5) maculopapular cutaneous eruptions, and (6) cervical lymphadenopathy. The cutaneous eruption characteristically involves the extremities and desquamates in the later stages. The disease may occur in cyclic epidemics, supporting an infectious hypothesis. It was originally associated with toxin-producing *S. aureus*,<sup>21</sup> but more recently *Rickettsia*-like organisms have been demonstrated by electron microscopy. KD is usually benign and self-limited, although 2% of Japanese KD cases (nearly all male) experience sudden cardiac death<sup>22</sup> due to an acute thrombosis



of aneurysmally dilated coronary arteries secondary to direct vasculitic involvement.

The most typical ocular finding is bilateral nonexudative conjunctival vasodilatation, typically involving the bulbar conjunctiva, with medium to large sized blood vessels being tortuous and engorged. No ocular discharge or pretragal lymph nodes are noted. However, there appears to be an increase in neutrophilic infiltration in conjunctival epithelial cells.<sup>23</sup> Anterior uveitis is seen in up to 80% of patients and is usually mild, bilateral and symmetric without ciliary injection (most common in children >2 years of age);<sup>24</sup> superficial punctate keratitis is seen in 12% of patients. Vitreous opacifications and papilledema have been reported. Choroiditis has been reported in a case of infantile periarteritis nodosa, which may be indistinguishable from KD (see Chapter 12).

## UVEITIS

Uveitis may be anatomically classified as anterior, intermediate, posterior or diffuse. Patients typically complain of diminished or hazy vision accompanied by black floating spots. Severe pain, photophobia and blurred vision occur in cases of acute iritis or iridocyclitis. The major signs of anterior uveitis are pupillary miosis and ciliary/perilimbal flush (a peculiar injection seen adjacent to the limbus) that can be easily confused with conjunctivitis. Vitreous cells and cellular aggregates are characteristic of intermediate uveitis and can be seen with the direct ophthalmoscope. Cells, flare, keratic precipitates on the corneal endothelium, and exudates with membranes covering the ciliary body can be visualized with the slit lamp and indirect ophthalmoscopy.

Anterior uveitis may be confused with conjunctivitis because its primary manifestations are a red eye and tearing; ocular pain and photophobia are also present. Anterior uveitis may be an isolated phenomenon that presents to an ophthalmologist or may be associated with a systemic autoimmune disorder that presents to a general practitioner. It is found in approximately 50% of cases of HLA-linked spondyloarthropathies (HLA-B27, e.g. ankylosing spondylitis [sacroiliitis], Reiter's syndrome); infections, such as *Klebsiella* bowel infections (resulting from molecular mimicry), brucellosis, syphilis and tuberculosis; HLA B5, Bw22, A29, and D5 genotypes; and inflammatory bowel diseases (e.g. Crohn's disease). The inflammatory response in the anterior chamber of the eye results in an increased concentration of proteins (flare [i.e. Tyndall effect]), a constricted pupil (miosis) with afferent pupillary defect (a poor response to illumination), or cells in the aqueous humor. White cells can pool in the anterior chamber, forming a hypopyon, or stick to the endothelial surface of the cornea, forming keratic precipitates. The sequelae of anterior uveitis may be acute, resulting in synechia (adhesions of the posterior iris to the anterior capsule of the lens), angle-closure glaucoma (blockage of the drainage of the aqueous humor) and cataract formation.

Posterior uveitis commonly presents with inflammatory cells in the vitreous, retinal vasculitis and macular edema, which threatens vision. Posterior uveitis caused by toxoplasmosis occurs as a result of congenital transmission. Serologic assays for toxoplasmosis (enzyme-linked immunosorbent assay or immunofluorescent antibody) assist in the diagnosis.<sup>25</sup>

Panuveitis is the involvement of all three portions of the uveal tract, including the anterior, intermediate (pars plana) and posterior sections. In an Israeli study it was clearly linked

(over 95% of cases) to a systemic autoimmune disorder, such as Behçet's disease.<sup>26</sup>

## SARCOIDOSIS

Sarcoidosis is rare in children; 50% to 80% have ocular involvement associated with anterior, intermediate, posterior or diffuse nongranulomatous uveitis. Classically, noncaseating granulomas appear as 'mutton fat precipitates', obstructive glaucoma, Koeppe nodules at the pupillary margin, or sheathing of vessels ('candle wax drippings'). The ocular inflammatory response may occur independently of any evidence of systemic involvement. Diagnostic tests include biopsy of the conjunctival or lacrimal granulomas, serum angiotensin-converting enzyme and lysozyme, chest radiograph for hilar adenopathy, and gallium scan. Biopsy of the lacrimal gland, the conjunctiva or the periocular skin is only useful when direct visualization reveals a nodule. Other granulomatous processes involving the eye include toxocariasis, tuberculosis and histoplasmosis, which may occur months to years after the primary infection.

## JUVENILE RHEUMATOID ARTHRITIS

Juvenile rheumatoid arthritis (JRA), now more commonly referred to as juvenile idiopathic arthritis (JIA) and accounting for 70% of chronic arthritis in children, exists as three subtypes: (1) systemic JIA (10–20%), usually characterized by a febrile onset, lymphadenopathy and evanescent rash; (2) polyarticular JIA (30–40%), characterized by involvement of multiple (>4) joints with few systemic manifestations; and (3) pauciarticular JIA (40–50%), characterized by no more than four joints involved, usually larger joints, and a positive antinuclear antibody (≈75%). Anterior uveitis can develop in all types although it is seen most often in pauciarticular JIA (≈25%). JIA is associated with chronic bilateral iridocyclitis and Russell bodies (large crystalline deposits of immunoglobulin in the iris). Ocular manifestations do not parallel the patient's arthritis; instead, onset generally occurs within 7 years after joint inflammation, so frequent screening and early detection are crucial to decrease the risk of vision loss.

## BLEPHARITIS (TABLE 54-4)

Blepharitis, inflammation of the eyelid margin, is one of the most common causes of pediatric red eye and is often misdiagnosed as an ocular allergy. It may be either anterior, involving the lash line, or posterior, involving a dysfunction of the meibomian glands; both are strongly associated with dermatologic disorders including atopic dermatitis and rosacea. Anterior and posterior blepharitis often occur together due to their common association with dermatologic disorders.

A specific form of anterior blepharitis involves colonization of the lid margin by *Staphylococcus aureus*. Coagulase-negative staphylococci colonize the normal lid without causing blepharitis (positive cultures of normal lid 6–15%) and thus a culture is not sufficient for diagnosis. However, it is known that 76% of blepharitis cases are associated with atopic dermatitis, while ulcerative blepharitis is almost exclusively associated with atopic dermatitis. Staphylococci may contribute to the development of conjunctivitis via direct infection as well as enterotoxin<sup>27</sup> or, indirectly, lipids because the bacteria release esterases and lipases generating fatty acids that can act as direct irritants.

TABLE  
54-4**Blepharoconjunctivitis: Inflammation of the Eyelid Can Involve Different Portions of the Anterior and Posterior Eyelid (Either Alone or in Combination)**

	ANTERIOR		Posterior Meibomian Gland Dysfunction	Anterior and Posterior Blepharo-Keratoconjunctivitis
	Staphylococcal	Seborrheic		
Lashes	Soft scales around roots	Soft greasy scales in between eyelashes	Unremarkable	Crusty
Lid margin	Ulceration Notching microabscesses	Shiny	Posterior oil capping with occlusion of meibomian glands	Chronic anterior and posterior involvement
Tear film	Dry	Dry	Dry and frothy	Dry
Conjunctiva	Papilla Phlyctenules	Unremarkable	Unremarkable	Follicular and papillary hypertrophy
Cornea	Punctate erosions Marginal infiltrates	Punctate erosions Peripheral infiltrates	Punctate erosions	Punctate erosion, vascularizations
Associated dermatitis	Atopic dermatitis	Seborrheic dermatitis	Acne rosacea	None
Cysts	Hordeolum		Meibomian	Styes (often multiple) and meibomian gland blockage

Patients typically complain of persistent burning, itching, tearing and a feeling of 'dryness'. These symptoms tend to be more severe in the morning and an exudative crust may be present leading to a child's eye becoming 'glued shut'. The signs of staphylococcal blepharitis include conjunctival injection, dilated blood vessels, erythema, scales, collarettes of exudative material around the eyelash bases, crusting, lid ulceration, folliculitis, foamy exudates in the tear film, telangiectasias, the loss of eyelashes (madarosis) in more chronic forms and even chronic papillary conjunctivitis. In addition, corneal immune deposits may cause severe photophobia. Treatment is directed toward eyelid hygiene with detergents (baby shampoo) and steroid ointments applied to the lid margin.

Posterior blepharitis is primarily manifested by meibomian gland obstruction that may result in an acute infection (internal hordeolum or stye) but more commonly produces a chalazion (a localized granulomatous inflammation caused by an accumulation of lipids and waxes within the meibomian gland). Chalazion clinically results in edema, erythema and burning of the eyelid that evolves into a firm, painless nodule. Bilateral eye involvement and conjunctivitis may also be present, which further contribute to allergic mimicry; once again, eyelid hygiene is the mainstay of therapy. In the ophthalmologic literature, 'hyposensitization' has been proposed for the subset of cell-mediated associated staphylococcal blepharoconjunctivitis.

*Phthirus pubis*, the pubic or crab louse, has a predilection for eyelash infestation<sup>29</sup> and may also cause blepharitis. Often the lice may be visualized with direct inspection. Involvement of the eyelashes in prepubertal children should raise the suspicion of sexual abuse.

Ocular rosacea is a rare cause of blepharitis in children, although it is believed to be underdiagnosed due to its typically mild symptoms.<sup>30,31</sup> The majority of cases are unilateral and present with a chronic red eye or recurrent chalazia with a female:male ratio of 3:1. Conjunctival phlyctenules that appear as clear vesicles are pathognomonic for this condition, and are thought to arise from inflammation directed against the bacterial flora of the eyelids. Treatment with lid hygiene, antibiotics, topical corticosteroids and topical cyclosporine may prevent serious complications including corneal involvement.

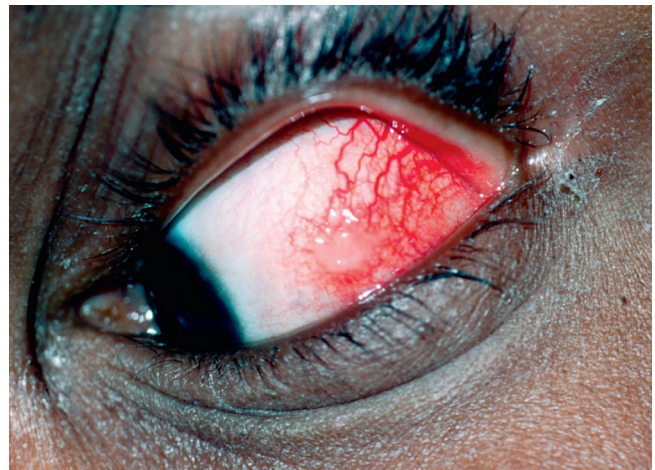

**Figure 54-8** Localized bulbar conjunctival vascular injection in a patient with nodular episcleritis.

## EPISCLERITIS

Inflammation of the scleral surface is termed *episcleritis*. It occurs mainly in adolescents and young adults, presenting as a localized injection of the conjunctiva around the lateral rectus muscle insertion (Figure 54-8). Typically, the inflammation is bilateral and accompanied by ocular pain. The presence of pain and absence of pruritus distinguishes episcleritis from allergic conjunctivitis. Episcleritis is self-limited and usually not associated with systemic disease.

## CONTACT DERMATOCONJUNCTIVITIS

Contact dermatitis involving the eyelids frequently causes the patient to seek medical attention for a cutaneous reaction that elsewhere on the skin would be of less concern. The eyelid skin, being soft, pliable and thin, has an increased susceptibility to contact dermatitis. Initially there is erythema and edema associated with ipsilateral conjunctivitis with thickening and crusting noted in cases of longer standing. Cosmetics are a major offender, but in the pediatric population it may be due

to ophthalmic medications or preservatives. Ophthalmic lubricants such as thimerosal, which are found in contact lens cleaning solutions and other topical agents, have been shown by patch tests to be among the culprits. Because of the high incidence of irritant false-positive reactions, patch testing is generally used only as a confirmatory tool.

## ANGIOEDEMA

Angioedema is the swelling of the dermis, and the conjunctiva is one of the most commonly involved sites in a variety of systemic hypersensitivity reactions. A documented local IgE-mast cell sensitization has been reported to papain enzyme in contact lens cleaning solution in which serum specific IgE to papain and chymopapain was detected.<sup>32</sup> The anatomy of the eyelid consists of loose epidermal tissue that provides an extensive reservoir for edema to even minor allergic reactions, but the differential diagnosis of periorbital cellulitis, which may be life-threatening, should also be considered.

## ATAXIA-TELANGIECTASIA

### Louis-Bar's Syndrome

Ataxia-telangiectasia presents with large tortuous vessels on the bulbar conjunctiva, most prominent in the exposed canthal regions<sup>33</sup> (Figure 54-9), that typically become evident between 1 and 6 years of age and progress with time. There are no other signs or symptoms of conjunctivitis. These children eventually develop ataxia, hypogammaglobulinemia (with absent or deficient IgA) and recurrent sinopulmonary infections.<sup>34</sup>

## ACQUIRED IMMUNODEFICIENCY SYNDROME

Children stricken with acquired immunodeficiency syndrome (AIDS) rarely have eye involvement. Cytomegalovirus retinitis is the most frequently encountered disorder, affecting approximately 7% of children with AIDS, and can lead to permanent vision loss if untreated. It is characterized by regions of intraretinal hemorrhage and white areas of edematous retina. HIV cotton-wool spots retinitis, herpes zoster retinitis and toxoplasmosis retinitis have also been documented in children.



**Figure 54-9** Tortuous conjunctival vessels on the bulbar conjunctiva in a patient with ataxia-telangiectasia.

## INFECTIONS

### Conjunctivitis

With increasing contact lens wear in the pediatric population there has been an increase in bacterial conjunctivitis and thus parents and children should be vigilant with eyelid hygiene and contact lens procedures.<sup>35</sup>

### Cellulitis

Orbital cellulitis is an infectious process that involves the extraocular contents and presents with a key symptom of 'pain' as well as lid edema, proptosis and diplopia due to involvement of extraocular muscles, in contrast to other allergic disorders affecting the eye. A majority of cases are due to extension of sinusitis with the most common pathogens being *Streptococcus pyogenes*, *Staphylococcus aureus* and *Haemophilus influenzae*. Preseptal cellulitis may resemble orbital cellulitis with intense lid swelling except that there is normal ocular movement and there is no inflammation of the globe. However, delay in diagnosis may lead to extension of infection into the orbit. The infectious agents are the same as in orbital cellulitis. A more lethal form of a deep subcutaneous infection of the eyelid that evolves into a necrotizing fasciitis is caused by beta-hemolytic *S. pyogenes* Lancefield group A, C and G and *S. aureus* in 25% of cases. The underlying process is associated with septic thrombophlebitis of the dermal vessels that can lead to septicemia and is considered a medical emergency.

## TRANSPLANTATION

Bone marrow transplantation is associated with the development of xerophthalmia.

Corneal transplantation is one of the most frequently performed transplant procedures, in which a diseased cornea is replaced by a cadaveric cornea that must be harvested within 24 hours of death. Tissue typing is not required for initial transplants as the cornea is avascular. Repeated transplants may require tissue typing. The primary indication for corneal allografts is maintaining optical integrity. Keratoconus is the most common indication, but other keratopathies (e.g. interstitial keratitis, corneal scars or ulcers, herpetic keratitis) and endothelial dystrophies may also necessitate transplantation.

Ocular complications involving the conjunctiva and the lacrimal system are noted in patients undergoing bone marrow transplantation. In acute graft versus host disease (GVHD), conjunctival involvement progresses from erythema to chemosis, serosanguineous exudate, and ultimately to the sloughing of the conjunctiva and potentially the cornea (pseudomembranous conjunctivitis) (Table 54-5).<sup>36</sup> The lacrimal gland may develop a stasis picture with inspissated blockage of the

**TABLE 54-5** Clinical Staging of Conjunctival Acute GVHD

Stage 1	Hyperemia
Stage 2*	Hyperemia, chemosis, serosanguineous exudate
Stage 3	Pseudomembranous conjunctivitis
Stage 4	Pseudomembranous conjunctivitis with corneal epithelial sloughing

\*Occurs in 12% of patients and is associated with increased mortality ~90%.<sup>38</sup>

ductules. These complications are not commonly seen in solid heart/lung organ transplantation.<sup>37</sup> In chronic forms of GVHD there is increased scarring of the conjunctiva and lacrimal inflammation with over 50% of patients developing a dry eye and a Sjögren-like syndrome.

## Treatment

Once an allergic etiology is identified, treatment is approached in a stepwise fashion. Treatment can be divided into primary, secondary and tertiary interventions (Table 54-6), as well as acute (seasonal) versus chronic (persistent).

Current treatment is primarily aimed at restoring the patient's quality of life and may require at least 2 weeks of therapy.

## PRIMARY INTERVENTION

Nonpharmacologic interventions are commonly the first line of treatment to be considered. Interventions include minimizing or avoiding contact with environmental allergens, application of cool compresses to the eye, lubrication and use of disposable contact lenses, and the use of preservative-free lubricants.<sup>39,40</sup>

### Environmental Control

Avoidance of allergens remains the first option in the management of any ocular disorder.

### Cold Compresses

Cold compresses provide considerable symptomatic relief, especially from ocular pruritus. In general, all ocular

TABLE  
54-6

Overview of the Treatment of Pediatric Ocular Allergic Disorders in a Stepwise Format

Therapeutic Intervention	Clinical Rationale	Pharmaceutic Agents	Comments
<b>PRIMARY</b>			
Avoidance	Effective, simple in theory, typically difficult in practice		>30% symptom improvement
Cold compresses	Decrease nerve c-fiber stimulation, reduce superficial vasodilation		Effective for mild-to-moderate symptoms
Preservative-free tears	Lavage, dilutional effect	Artificial tears	Extremely soothing, recommend refrigeration to improve symptomatic relief, inexpensive OTC, safe for all ages, comfortable, use as needed
<b>SECONDARY</b>			
Topical antihistamine and decongestants	Antihistamine relieves pruritus, vasoconstrictor relieves injection	Antazoline naphazoline, pheniramine naphazoline	No prescription required, quick onset, more effective than systemic antihistamines, limited duration of action, frequent dosing required
Topical antihistamine and mast cell stabilizer (plus other mechanisms)	Single agent with multiple actions, has immediate and prophylactic activity, eliminates need for 2-drug therapy, comfort enhances patient compliance	Olopatadine (Patanol), ketotifen (Zaditor), azelastine (Optivar), bepotastine (Bepreve)	Twice-daily dosing, dual-acting agents, antihistamine, mast cell stabilizer, inhibitor of inflammatory mediators, more effective at relieving symptoms than other classes of agents, longer duration of action, safe and effective for 3 years and older
Topical mast cell stabilizers	Safe and effective for allergic diseases, especially those associated with corneal changes	Cromolyn (Crolom), lodoxamide (Alomide), nedocromil (Alocril), pemirolast (Alamast)	Cromolyn relieves mild-to-moderate symptoms of vernal keratoconjunctivitis, vernal conjunctivitis, vernal keratitis. Lodoxamide is highly potent
Topical antihistamines	Relieves signs and symptoms of pruritus and erythema	Levocabastine (Livostin), emedastine (Emadine)	Dosing 1–4 times daily, safe and effective for 3 years and older
Topical NSAIDs	Relieves pruritus	Ketorolac (Acular)	Stinging and/or burning on instillation experienced up to 40% of patients
<b>TERTIARY</b>			
Topical corticosteroids	Relieves all facets of the inflammatory response including erythema, edema and pruritus	Loteprednol (Lotemax, Alrex), rimexolone (Vexol), fluorometholone (FML)	Appropriate for short-term use only, contraindicated in patients with viral infections
Immunotherapy SCIT SLIT	Identify and modulate allergen sensitivity		Adjunctive, although may be considered in secondary treatment in conjunction with allergic rhinitis
<b>ANCILLARY</b>			
Oral antihistamines	Mildly effective for pruritus	Loratadine, fexofenadine, cetirizine	May cause dry eyes, worsening allergy symptoms; may not effectively resolve the ocular signs and symptoms of allergy

NSAID – Nonsteroidal antiinflammatory drug, OTC – over the counter.



medications provide additional subjective relief when refrigerated and immediately applied in a cold state.

### Lubrication

Many conditions require the use of lubricants for either temporary relief (e.g. seasonal ocular allergy, corneal abrasion) or for more long-term complications (e.g. keratoconjunctivitis sicca in patients undergoing bone marrow transplantation). Tear substitutes consist of a viscosity agent in three formulations in order to increase the length of action while decreasing the length of time vision is blurred after instillation: aqueous (seconds), gel (a few minutes) and ointment (~30 minutes). Ointments are best tolerated overnight. Most are buffered to pH 7.7–7.8 and contain a preservative. Artificial tears can be applied topically 2 to 4 times daily as necessary. If drops are used more than 4 times a day then a preservative-free preparation should be considered. Lubrication primarily assists in the direct removal and dilution of allergens that may come in contact with the ocular surface. Ocular lubricants vary by class, osmolarity and electrolyte composition; no product has yet emerged as a clear favorite. Patients should be given the name of one or two brands from each class of lubricant to try until a suitable product or combination of products is found.

### Contact Lenses

In general, adolescent patients who have seasonal allergy should avoid contact lens use during seasonal flare-ups. The need for clean lenses with minimal deposit build-up must be stressed, and the use of daily wear lenses with rigid disinfecting and cleaning techniques is recommended. Alternatively, daily disposable lenses should be used.<sup>41,42</sup> When such individuals wear contact lenses (CLs), a special set of circumstances arises that increases the risk of ocular infection. The risk is greatest if the lenses are soft and, therefore, provide for little tear exchange beneath their surface. Under such circumstances, limited tear flow allows for a greater build-up of lens deposits and metabolic wastes, while permitting increased tear evaporation from the lens surface.<sup>43</sup>

In a study evaluating the impact of daily disposable lenses versus patient's standard chronic wear lenses, 67% reported that the 1-day disposable lenses provided improved comfort in comparison to the lenses they wore prior to the study. This compared with 18% agreeing that the new pair of habitual lenses provided improved comfort, suggesting that the use of 1-day disposable lenses may be an effective strategy for managing allergy-suffering contact lens wearers.<sup>44</sup> Overall, the newer soft silicone lenses with increased gas permeability have had a higher comfort satisfaction rate (56%) than the rigid gas-permeable lens (14%), while 63% of nonatopic and only 47% of atopic subjects described their lenses as very comfortable to wear.<sup>45,46</sup>

## SECONDARY INTERVENTION – A STEP APPROACH<sup>47</sup>

The development of therapeutic agents to specifically address the various signs and symptoms of allergic inflammation of the conjunctival surface is ongoing. In the search for more effective medications for ocular allergy, the conjunctival allergen challenge (CAC), also known as the conjunctival provocation test (CPT), has been critical as a standardized model for the assessment of efficacy and duration of effect that new agents have on the allergy signs and symptoms of erythema (redness), pruritus

(itching), epiphora (tearing), lid swelling and conjunctival swelling (chemosis). Many of the newer agents are also being evaluated for potential treatment of the more chronic ocular allergy-associated disorders, such as atopic keratoconjunctivitis, or the potential to treat both ocular and nasal symptoms as the medication drains down the nasolacrimal duct onto the nasal mucosa.

### Decongestants

Topical decongestants act primarily as vasoconstrictors that are highly effective in reducing erythema and are widely used in combination with topical antihistamines. The decongestants are applied topically 2 to 4 times daily as necessary. They have no effect in diminishing the allergic inflammatory response. Vasocon-A is the only antihistamine/decongestant proven to be effective in treating the signs and symptoms (itch and redness) of allergic conjunctivitis. The usual dose is 1 to 2 drops per eye every 2 hours, up to four times daily. The primary contraindication is narrow-angle glaucoma. Excessive use of these agents has been associated with an increased conjunctival hyperemia known as the rebound phenomenon (a form of conjunctivitis medicamentosa).<sup>48</sup>

### Antihistamines

Initially, oral antihistamines were extensively employed to systemically control the symptoms of allergic rhinoconjunctivitis, although with an obvious delayed onset of action on the ocular domain when compared to topical antihistamine agents. However, oral antihistamine appears to have a longer biological half-life and can have a longer-lasting effect. Information on oral antihistamine use in the treatment of allergic conjunctivitis is commonly buried within studies on allergic rhinitis instead of *rhinoconjunctivitis*. Oral antihistamines, especially the older generation (e.g. chlorpheniramine), appear to have an effect on excessive tearing (lacrimation and epiphora).<sup>49</sup> Another assessment tool has been ocular challenge testing (OCT), which has shown that oral antihistamines, such as terfenadine or loratadine, can increase several-fold the tolerance to a dose of specific allergen treatment in children and adults.<sup>50,51</sup> Oral antihistamines can offer relief from the symptoms of ocular allergy but have a delayed onset of action. Newer, second-generation H<sub>1</sub> receptor (nonsedating) antagonists are less likely to cause unwanted sedative or anticholinergic (dry eye) effects compared to earlier compounds.<sup>52</sup> It has therefore been suggested that the concomitant use of an eye drop may treat ocular allergic symptoms more effectively.<sup>53</sup>

H<sub>1</sub> stimulation principally mediates the symptom of conjunctival pruritus whereas the H<sub>2</sub> receptor appears to be clinically involved in vasodilation.<sup>54–57</sup> Although topical antihistamines can be used alone to treat allergic conjunctivitis, they have been shown to have a synergistic effect when used in combination with a vasoconstrictor or when the agents themselves have been shown to have effects on other mediators of allergic inflammation. Dosing is 1 to 4 times daily and is safe for children 3 years and older.

In general, the older topical antihistamines are known to be irritating to the eye, especially with prolonged use, and may be associated with ciliary muscle paralysis, mydriasis, angle-closure glaucoma and photophobia, especially those that are nonselective and block muscarinic receptors. Interestingly, this effect is more pronounced in patients with lighter irides and has not been reported with the newer topical agents.

The newer topical antihistamines have also been found to have other potential antiinflammatory actions, such as mast cell stabilization, cytokine expression or interleukin release (discussed later in the chapter).

#### Antihistamines with Multiple Antiinflammatory Activities (Table 54-7)

**Olopatadine.** Olopatadine 0.01% (Patanol and Pataday) possesses antihistaminic activity and mast cell stabilizing effects. Olopatadine was approximately 10 times more potent as an inhibitor of cytokine secretion (50% inhibitory concentration 1.7–5.5 nmol/L) than predicted from binding data whereas antazoline and pheniramine were far less potent (20–140 times) in functional assays, including TNF- $\alpha$  mediator release from human conjunctival mast cells. Olopatadine has been shown to be significantly more effective than placebo in relieving itching and redness for up to 8 hours.<sup>58</sup> In a comparison study with another multiple-action agent, ketotifen, olopatadine fared only slightly better over 2 weeks.<sup>59</sup> In a reformulated form it has been approved for once a day treatment of ocular allergy (Pataday).<sup>60</sup>

**Epinastine.** Epinastine 0.05% (Elestat) is another topical antihistamine with other antiinflammatory properties that include H<sub>2</sub>-receptor antagonism, mast cell stabilization and inhibition of cytokine production. Pretreatment by epinastine differentially reduced histamine, TNF- $\alpha$  and - $\beta$ , IL-5, IL-8 and IL-10. In vivo, epinastine and olopatadine pretreatment significantly reduced clinical scores and eosinophil numbers while epinastine also reduced neutrophils ( $P < .02$ ), reflecting that there are different patterns of inhibition of inflammation.<sup>61</sup> The role of the histamine H<sub>1</sub>, H<sub>2</sub> and H<sub>3</sub> receptor affinities is unclear in the actual treatment, but from past clinical experience it would appear that having such multiple binding would be beneficial. In an animal model of histamine-induced vascular leakage, epinastine, azelastine and ketotifen had a shorter duration of effect than olopatadine.<sup>62</sup> In CAC placebo trials, multiple signs and symptoms (ocular itching, eyelid swelling, conjunctival and episcleral hyperemia, and chemosis) of allergic conjunctivitis were significantly reduced by instillation of epinastine compared with vehicle.<sup>63</sup>

**Bepotastine.** Bepotastine 1.5% (Bepreve) is the newest of the FDA-approved ophthalmic antihistamines. There is evidence for multiple antiinflammatory properties that include H<sub>1</sub>-receptor antagonism, mast cell stabilization and inhibition of cytokine production including IL-5.<sup>58,64,65</sup> Pretreatment by bepotastine differentially reduced IL-5 as well as itching associated with LTB-4 injection in an animal model.<sup>65,66</sup> The agent also appears to have the highest selectivity for H<sub>1</sub>.<sup>67</sup> Bepotastine besilate was originally developed in Japan by Tanabe in conjunction with Ube Industries and was approved in Japan as an oral preparation (Talion) in July 2000 for the treatment of allergic rhinitis and subsequently approved for the treatment of pruritus/itching accompanying urticaria and other skin conditions in January 2002. Since bepotastine relieves antihistamine-resistant pruritus, it is possible that mechanisms of action other than H<sub>1</sub> receptor antagonism are also responsible for the antipruritic effects of this agent. In CAC placebo trials, multiple signs and symptoms (ocular itching, eyelid swelling, tearing, total nonocular symptoms score, nasal congestion and rhinorrhea) of allergic conjunctivitis were significantly reduced by instillation of bepotastine compared with vehicle.<sup>68,69</sup>

**Ketotifen.** Ketotifen 0.025% (Zaditor) is a benzocycloheptathiophene that has been shown to display several antimediator properties, including strong H<sub>1</sub> receptor antagonism and inhibition of leukotriene formation.<sup>70,71</sup> Ketotifen has also been shown to have pronounced antihistaminic and antianaphylactic properties that result in moderate to marked symptom improvement in the majority of patients with asthma, atopic dermatitis, seasonal or perennial rhinitis, allergic conjunctivitis, chronic or acute urticaria and food allergy. Ketotifen is distinguished from the sodium cromolyn and nedocromil, by a conjoint mast cell stabilizer with, several antimediator properties including strong H<sub>1</sub> receptor antagonism and inhibition of leukotriene formation.<sup>72</sup> It is now available as an over-the-counter therapy for ocular allergy.

**Azelastine.** Azelastine 0.05% (Optivar) is a second-generation H<sub>1</sub> receptor antagonist. It was demonstrated in a pediatric SAC

TABLE 54-7 Topical Multiple Action Agents for Treatment of Ocular Allergy

	Azelastine HCl 0.05% (Optivar)	Epinastine HCl 0.05% (Elestat)	Ketotifen Fumarate 0.25% (Zaditor)*	Olopatadine HCl 0.2% (Pataday)	Bepotastine Besilate 1.5% (Bepreve)	Alcaftadine 0.25% (Lastacaft)
Indication	Relief of itching associated with allergic conjunctivitis	Relief of itching associated with allergic conjunctivitis	Temporary prevention of itching of the eye caused by allergies	Relief of itching associated with allergic conjunctivitis	Treatment of itching associated with allergic conjunctivitis	Prevention of itching associated with allergic conjunctivitis
Dosage	1 drop in each affected eye twice a day	1 drop in each affected eye twice a day (age 3 yr and older)	1 drop in each affected eye every 8–12 hr	1 drop in each affected eye once a day	1 drop in each affected eye twice a day (age 2 yr and up)	1 drop in each eye daily (2 years or older)
Adverse event	Transient sting ( $\approx$ 30%) Headache ( $\approx$ 15%) Bitter taste ( $\approx$ 10%)	Cold symptoms ( $\approx$ 10%) Upper respiratory infection ( $\approx$ 10%)	Headache ( $\approx$ 10–25%) Conjunctival injection ( $\approx$ 10–25%) Rhinitis ( $\approx$ 10–25%)	Cold syndrome ( $\approx$ 10%) Pharyngitis ( $\approx$ 10%)	Taste ( $\approx$ 25%)	Eye irritation, burning and/or stinging upon instillation (<4%)

\*Ketotifen (Zaditor) is now available over the counter in the USA.

study that the response rate in the azelastine eye drops group (74%) was significantly higher than that in the placebo group (39%) and comparable with that in the levocabastine group.<sup>73</sup> Apart from the ability to inhibit histamine release from mast cells and to prevent the activation of inflammatory cells, it is likely that the antiallergic potency of azelastine is partially the result of down-regulation of ICAM-1 expression during the early- and late-phase components of ocular allergic response, probably leading to a reduction of inflammatory cell adhesion to epithelial cells and confirming the prophylactic properties of azelastine.<sup>74</sup> It is safe to use in children 3 years and older.

**Alcaftadine.** Alcaftadine 0.25% (Lastacast) is an antihistamine with affinity to H<sub>1</sub>, H<sub>2</sub> and less to H<sub>4</sub> receptors that is superior to placebo and as effective as olopatadine 0.1% in preventing ocular itching and conjunctival redness at 15 minutes and 16 hours after administration.<sup>75</sup> Interestingly, in an animal model for allergic conjunctivitis, alcaftadine demonstrated a decrease of eosinophil infiltration when compared to controls and olopatadine.<sup>76</sup> It is approved for children 2 years and older.

### Mast Cell Stabilizers

**Cromolyn.** Cromolyn 4% (Crolom) is the prototypic mast cell stabilizer. The efficacy of this medication appears to be dependent on the concentration of the solution used (i.e. 1% – no effect, 2% – possible effect, and 4% solution – probable effect).<sup>40,77</sup> Sodium cromolyn was originally approved for more severe forms of conjunctivitis with corneal involvement (e.g. GPC, VKC) but many physicians have used it for the treatment of SAC and PAC with an excellent safety record, although the original studies reflecting its clinical efficacy were marginal when compared to placebo<sup>51,54</sup> and in some animal models.<sup>78</sup> Cromolyn sodium 4% ophthalmic solution requires application 4 to 6 times daily for effectiveness. It is approved for children 3 years and older. The major adverse effect is burning and stinging, which has been reported in 13% to 77% of patients treated.

**Lodoxamide.** Lodoxamide 0.1% (Alomide) is a mast cell stabilizer that is approximately 2,500 times more potent than cromolyn in the prevention of histamine release in several animal models.<sup>79</sup> Lodoxamide is effective in reducing tryptase and histamine levels and the recruitment of inflammatory cells in the tear fluid after allergen challenge,<sup>54,55</sup> as well as tear eosinophil cationic protein<sup>80</sup> and leukotrienes (BLT and CysLT<sub>1</sub>) when compared to cromolyn. In early clinical trials lodoxamide (0.1%) was shown to deliver greater and earlier relief in patients with more chronic forms, such as VKC, including upper tarsal papillae, limbal signs (papillae, hyperemia and Trantas' dots) and conjunctival discharge, and to improve epithelial defects seen in the chronic forms of conjunctivitis (VKC, GPC) than cromolyn.<sup>81</sup> In patients with allergic conjunctivitis, it is approved for the treatment of VKC at a concentration of 0.1% four times daily. Lodoxamide may be used continuously for 3 months in children older than 2 years of age.

**Pemirolast.** Pemirolast potassium 0.1 % (Alamast) is a mast cell stabilizer for the prevention and relief of ocular manifestations of allergic conjunctivitis. It was originally marketed for the treatment of bronchial asthma and allergic rhinitis and then registered in Japan as an ophthalmic formulation for the treatment of allergic and vernal conjunctivitis.<sup>82</sup> It has been studied

in children as young as 2 years of age, with no reports of serious adverse events. In various animal and in vitro studies it was found to be superior and, in others, equivalent to cromolyn.<sup>83</sup> The usual regimen is 1 to 2 drops four times daily for each eye.

**Nedocromil.** Nedocromil 2% (Alocril) is a pyranoquinoline derivative of cromolyn that inhibits various activities on multiple cells involved in allergic inflammation including eosinophils, neutrophils, macrophages, mast cells, monocytes and platelets. Nedocromil inhibits activation and release of inflammatory mediators such as histamine, prostaglandin D<sub>2</sub> and leukotriene C<sub>4</sub> from eosinophils. The mechanism of action of nedocromil may be due partly to inhibition of axon reflexes and release of sensory neuropeptides, such as substance P, neurokinin A and calcitonin gene-related peptides. Nedocromil does not possess any antihistamine or corticosteroid activity.<sup>84</sup> Nedocromil has been shown to improve clinical symptoms in the control of ocular pruritus and irritation in the treatment of SAC.<sup>85–92</sup> Its safety profile is similar to that of sodium cromolyn, but it is more potent and can be given just twice daily. The results of several placebo-controlled studies have shown that nedocromil is effective in alleviating the signs and symptoms of SAC and provides relief in approximately 80% of patients.<sup>86</sup> In a study comparing nedocromil (2%) with cromolyn eye drops, nedocromil was more efficacious in its impact on hyperemia, keratitis, papillae and pannus formation with less time to have an effect on itching, grittiness, hyperemia and keratitis.<sup>87</sup>

### Nonsteroidal Antiinflammatory Drugs

Topically applied inhibitors of the cyclooxygenase system (1% suprofen)<sup>88</sup> have been used in the treatment of VKC.<sup>87,88</sup> Oculfen (diclofenac) is one of three topical NSAIDs approved for the treatment of intraocular inflammatory disorders. Another topically applied NSAID (0.03% flurbiprofen) has been examined for the treatment of allergic conjunctivitis and was found to decrease conjunctival, ciliary and episcleral hyperemia and ocular pruritus when compared to the control (vehicle-treated eyes). Pruritus is associated with prostaglandin release. It has been shown that prostaglandins can lower the threshold of human skin to histamine-induced pruritus, which may also be the primary benefit of these medications in the eye.

**Ketorolac Tromethamine.** Ketorolac tromethamine (Acular, Allergan) was approved for the treatment of SAC with a primary mechanism of action on the inhibition of cyclooxygenase, thus blocking the production of prostaglandins but not the formation of leukotrienes. Clinical studies have shown that prostanooids are associated with ocular itching and conjunctival hyperemia and thus inhibitors can interfere with ocular itch and hyperemia produced by antigen-induced and seasonal allergic conjunctivitis.<sup>89–91</sup> NSAIDs (e.g. ketorolac) do not mask ocular infections, affect wound healing, increase IOP or contribute to cataract formation, unlike topical corticosteroids. A recent study compared diclofenac sodium with ketorolac tromethamine and the results for both agents were similar.<sup>92</sup> Treatment group differences were observed for the pain/soreness score with an advantage observed for the diclofenac sodium group over ketorolac tromethamine (20.7% versus 3.2%). Ketorolac and other NSAIDs are classically associated with a low-to-moderate incidence of burning and stinging upon instillation into the eye.

## TERTIARY INTERVENTION

### Topical Corticosteroids

When topically administered medications such as antihistamines, vasoconstrictors, cromolyn sodium and other multiple-action agents are ineffective, mild topical steroids are a consideration. Topical corticosteroids are highly effective in the treatment of acute and chronic forms of allergic conjunctivitis and are even required for control of some of the more severe variants of conjunctivitis including VKC and GPC. However, local administration of these medications is not without possible localized ocular complications including increased IOP (e.g. in glaucoma), viral infections and cataract formation. Topically or systemically administered steroids will produce a transient rise in IOP in susceptible individuals; this trait is thought to be genetically influenced.<sup>91,93-95</sup> Unlike efficacy, which varies among the steroid esters, IOP effects are consistent among the different esters of the same corticosteroid base.

**Loteprednol.** Loteprednol 0.2% (Alrex) is an ophthalmic suspension approved for the treatment of ocular allergy. One of its unique features is its claim to be a site-specific steroid (i.e. the active drug resides at the target tissue long enough to render a therapeutic effect but rarely long enough to cause secondary effects such as increased IOP and posterior subcapsular cataract development). The higher dose loteprednol (0.5%) formulation has been shown to be effective in reducing the signs and symptoms of GPC, acute anterior uveitis and inflammation following cataract extraction with intraocular lens implantation,<sup>91</sup> and as prophylactic treatment for the ocular signs and symptoms of SAC administered 6 weeks before the onset of the allergy.<sup>93</sup>

It is recommended that only patients with more chronic forms of allergic conjunctivitis use topical steroids in a routine manner. Ophthalmologic consultation should be obtained for any patient using ocular steroids for more than 2 weeks to assess cataract formation or increased IOP. Consultation is also merited for any persistent ocular complaint or if the use of strong topical steroids or systemic steroids is being considered.

### Immunotherapy

The efficacy of allergen immunotherapy is well established, although it appears that allergic rhinitis may respond better to treatment than allergic conjunctivitis.<sup>96</sup> Similarly, for allergic patients who had asthma and rhinoconjunctivitis when exposed to animal dander (Fel d-I allergen), immunotherapy clearly improved the overall symptoms of rhinoconjunctivitis, decreased the use of allergy medications and required a 10-fold increase in the dose of allergen to induce a positive OCT reaction after 1 year of immunotherapy with the specific cat allergen.<sup>97</sup> Symptom assessment post challenge for ragweed-sensitive patients treated for at least 2 years with specific ragweed immunotherapy revealed improvement in nasal more than ocular symptoms when compared with controls.<sup>98</sup> The effect of immunotherapy specific for Japanese cedar (*Cryptomeria japonica*) pollenosis had reduced the daily total symptom medication score, not only in cedar but also in the cross-allergenic Japanese cypress (*Chamaecyparis obtusa*) pollination season, but not significantly.<sup>99</sup> Thus immunotherapy plays more of an important role in the 'long-term' control of SAC.

## New Directions and Future Developments

Cyclosporine was FDA approved in 2002 as an ophthalmic solution to increase tear production in patients with tear film dysfunction. The safety and efficacy of ophthalmic cyclosporine, however, has not been established in patients under 16 years of age. This agent acts on IL-2, which has an immunomodulatory effect on the activation of T lymphocytes. Studies and reports on the use of topical cyclosporine in cases of VKC have demonstrated marked and lasting improvement in symptoms.<sup>13</sup> Likewise, tacrolimus has been shown to improve the signs and symptoms of VKC when administered as an ophthalmic solution or ointment, with results occurring in as little as 1 week.<sup>100,101</sup> Tacrolimus is a macrolide antibiotic that acts primarily on T lymphocytes by inhibiting the production of lymphokines, particularly IL-2. It has been effective in the treatment of immune-mediated ocular diseases such as corneal graft rejection, keratitis, scleritis, ocular pemphigoid and uveitis. The drug is approximately 100 times as potent as cyclosporine. Both tacrolimus and cyclosporine have been shown in vitro to inhibit histamine release.<sup>102</sup>

Alternative delivery systems for topical agents are also under investigation. Immunization approaches using 'naked plasmid' DNA (pDNA) are being pursued. This approach induces an altered antiallergic immune state in which there is a preference for the T helper cell type 1 response, producing primarily IgG2a whereas allergens would normally induce an IgG1 and IgE response.<sup>102,103</sup> Additional areas of future research include cytokine antagonists and anti-IgE therapy.<sup>15</sup>

Sublingual immunotherapy has been approved for use in Europe and appears to have potential for patients with single allergen-induced symptoms. It is undergoing multiple clinical studies for its efficacy and cost effectiveness in studies in the USA.<sup>103-105</sup>

Recent studies have demonstrated the potential of the positive impact of intranasal treatment (intranasal steroids and possibly intranasal antihistamines) on allergic rhinitis and its associated ocular allergy symptoms.<sup>106-108</sup> It appears that this treatment would be best for mild-to-moderate cases, such as in seasonal allergic conjunctivitis (more than in perennial allergic conjunctivitis). Such patients would still benefit the most from topical allergy medications.

Evidence shows that herbal remedies (e.g. butterbur, *Urtica dioica*, citrus unshiu powder), dietary products (e.g. *Spirulina*, cellulose powder), Indian Ayurvedic medicine and Traditional Chinese medicine have an effect on the symptoms of allergic rhinoconjunctivitis.<sup>109,110</sup> Randomized, placebo-controlled trials are needed to evaluate the safety and efficacy of complementary and alternative medicine in both children and adults.

## Conclusions

Ocular disorders in children seen in the clinical subspecialty of allergy and immunology are increasing as our basic understanding of underlying mechanisms of the eye's immune response coupled with a stepwise diagnostic approach facilitates proper diagnosis and treatment, especially for allergic disorders (Boxes 54-1 and 54-2). As we develop a greater understanding of the biomolecular mechanisms of these disease states, treatment will continue to progress from symptomatic relief to more directed therapeutic interventions.



**BOX 54-1 KEY CONCEPTS****Allergic Eye Disease**

- Conjunctivitis caused by IgE mast cell-mediated reactions is the most common hypersensitivity response of the eye.
- Seasonal allergic conjunctivitis is the most common allergic conjunctivitis, representing over half of all cases.
- Grass pollen, dust mites, animal dander and feathers are the most common allergens.
- Most environmental allergens affect both eyes at once.
- The hallmark of allergic conjunctivitis is pruritus.
- A stringy or ropy discharge may also be characteristic of allergy.
- A detailed history is the cornerstone of proper diagnosis.
- Eye examination: simple observation alone may be diagnostic.
- Ocular inflammation caused by systemic immunologic diseases is frequently observed in children.
- Immunologic disorders of the eye commonly affect the interior portion of the visual tract and are associated with visual disturbances.

**BOX 54-2 THERAPEUTIC PRINCIPLES****Allergic Eye Disease**

- Approached in a stepwise fashion:  
*Primary:* avoidance, cold compresses, artificial tears  
*Secondary:* topical antihistamines, decongestants, mast cell stabilizers, nonsteroidal antiinflammatory drugs, multiple action agents  
*Tertiary:* Topical corticosteroids, immunotherapy (immunotherapy may be considered in the secondary category for some cases)
- Novel approaches: cyclosporine, tacrolimus, liposomal drug delivery systems, cytokine antagonists, anti-IgE therapy, complementary and alternative medicine
- Ophthalmology consultation is merited for any persistent ocular complaint or if the use of strong topical steroids or systemic steroids is being considered

The complete reference list can be found on the companion Expert Consult website at <http://www.expertconsult.inkling.com>.

**KEY REFERENCES**

- Bielory L. Allergic and immunologic disorders of the eye. Part I. Immunology of the eye. *J Allergy Clin Immunol* 2000;106:805–16.
- Lemp MA. Advances in understanding and managing dry eye disease. *Am J Ophthalmol* 2008;146:350–6.
- Bielory L. Differential diagnoses of conjunctivitis for clinical allergist-immunologists. *Ann Allergy Asthma Immunol* 2007;98:105–14, quiz 14–7, 52.
- Bielory L. Allergic and immunologic disorders of the eye. Part II. Ocular allergy. *J Allergy Clin Immunol* 2000;106:1019–32.
- Rosenbaum JT. An algorithm for the systemic evaluation of patients with uveitis: guidelines for the consultant. *Semin Arthritis Rheum* 1990;19:248–57.
- Bielory L, Mongia A. Current opinion of immunotherapy for ocular allergy. *Curr Opin Allergy Clin Immunol* 2002;2:447–52.
- Alvarez-Cuesta E, Cuesta-Herranz J, Puyana-Ruiz J, Cuesta-Herranz C, Blanco-Quirós A. Monoclonal antibody-standardized cat extract immunotherapy: risk-benefit effects from a double-blind placebo study. *J Allergy Clin Immunol* 1994;93:556–66.
- Donovan JP, Buckeridge DL, Briscoe MP, Clark RH, Day JH. Efficacy of immunotherapy to ragweed antigen tested by controlled antigen exposure. *Ann Allergy Asthma Immunol* 1996;77:74–80.
- Origlieri C, Bielory L. Intranasal corticosteroids and allergic rhinoconjunctivitis. *Curr Opin Allergy Clin Immunol* 2008;8:450–6.
- Bielory L, Heimall J. Review of complementary and alternative medicine in treatment of ocular allergies. *Curr Opin Allergy Clin Immunol* 2003;3:395–9.

## REFERENCES

- Ray NF, Baraniuk JN, Thamer M, Rinehart CS, Gergen PJ, Kaliner M, et al. Direct expenditures for the treatment of allergic rhinoconjunctivitis in 1996, including the contributions of related airway illnesses. *J Allergy Clin Immunol* 1999;103(3 Pt 1):401-7.
- Marrache F, Brunet D, Frandeboeuf J. The role of ocular manifestations in childhood allergy syndromes. *Rev Fr Allergol Immunol Clin* 1978;18:151-5.
- Singh K, Axelrod S, Bielory L. The epidemiology of ocular and nasal allergy in the United States, 1988-1994. *J Allergy Clin Immunol* 2010;126:778-783 e776.
- Bielory L, Syed BA. Pharmacoeconomics of anterior ocular inflammatory disease. *Curr Opin Allergy Clin Immunol* 2013;13:537-42.
- Bielory L. Allergic and immunologic disorders of the eye. Part I. Immunology of the eye. *J Allergy Clin Immunol* 2000;106:805-16.
- Gillette TE, Chandler JW, Greiner JV. Langerhans cells of the ocular surface. *Ophthalmology* 1982;89:700-11.
- Irani AA. Ocular mast cells and mediators. In: Bielory L, editor. *Ocular allergy*. New York: W.B. Saunders; 1997. p. 1-17.
- Irani AM, Butrus SI, Tabbara KF, Schwartz LB. Human conjunctival mast cells: distribution of MCT and MCTC in vernal conjunctivitis and giant papillary conjunctivitis. *J Allergy Clin Immunol* 1990;86:34-40.
- Lemp MA. Advances in understanding and managing dry eye disease. *Am J Ophthalmol* 2008;146:350-6.
- Bielory L. Differential diagnoses of conjunctivitis for clinical allergist-immunologists. *Ann Allergy Asthma Immunol* 2007;98:105-14, quiz 14-7, 52.
- Wald ER, Greenberg D, Hoberman A. Short term oral cefixime therapy for treatment of bacterial conjunctivitis. *Pediatr Infect Dis J* 2001;20:1039-42.
- Murphy TF, Faden H, Bakaletz LO, Kyd JM, Forsgren A, Campos J, et al. Nontypeable *Haemophilus influenzae* as a pathogen in children. *Pediatr Infect Dis J* 2009;28:43-8.
- Mendicutte J, Aranzasti C, Eder F, Ostolaza JI, Salaberria M. Topical cyclosporin A 2% in the treatment of vernal keratoconjunctivitis. *Eye* 1997;11(Pt 1):75-8.
- Choi SH, Bielory L. Late-phase reaction in ocular allergy. *Curr Opin Allergy Clin Immunol* 2008;8:438-44.
- Bielory L. Allergic and immunologic disorders of the eye. Part II. Ocular allergy. *J Allergy Clin Immunol* 2000;106:1019-32.
- Dart JK, Buckley RJ, Monnickendam M, Prasad J. Perennial allergic conjunctivitis: definition, clinical characteristics and prevalence. A comparison with seasonal allergic conjunctivitis. *Trans Ophthalmol Soc U K* 1986;105(Pt 5): 513-20.
- Abelson MB, Baird RS, Allansmith MR. Tear histamine levels in vernal conjunctivitis and other ocular inflammations. *Ophthalmology* 1980;87:812-14.
- Udell IJ, Gleich GJ, Allansmith MR, Ackerman SJ, Abelson MB. Eosinophil granule major basic protein and Charcot-Leyden crystal protein in human tears. *Am J Ophthalmol* 1981;92:824-8.
- Mumcuoglu YK, Zavaro A, Samra Z, Lazarowitz Z. House dust mites and vernal keratoconjunctivitis. *Ophthalmologica* 1988; 196:175-81.
- Tripathi PC, Tripathi RC. Analysis of glycoprotein deposits on disposable soft contact lenses. *Invest Ophthalmol Vis Sci* 1992;33:121-5.
- Leung DY, Meissner HC, Fulton DR, Murray DL, Kotzin BL, Schlievert PM. Toxic shock syndrome toxin-secreting *Staphylococcus aureus* in Kawasaki syndrome. *Lancet* 1993;342: 1385-8.
- Dreborg S, Agrell B, Foucard T, Kjellman NI, Koivikko A, Nilsson S. A double-blind, multi-center immunotherapy trial in children, using a purified and standardized *Cladosporium herbarum* preparation. I. Clinical results. *Allergy* 1986;41:131-40.
- Al-Abbadi MA, Abuhammour W, Harahsheh A, Abdel-Haq NM, Hasan RA, Saleh HA. Conjunctival changes in children with Kawasaki disease: cytopathologic characterization. *Acta Cytol* 2007;51:370-4.
- Bligard CA. Kawasaki disease and its diagnosis. *Pediatr Dermatol* 1987;4:75-84.
- Rosenbaum JT. An algorithm for the systemic evaluation of patients with uveitis: guidelines for the consultant. *Semin Arthritis Rheum* 1990;19:248-57.
- Weiner A, BenEzra D. Clinical patterns and associated conditions in chronic uveitis. *Am J Ophthalmol* 1991;112:151-8.
- Fujishima H, Okada N, Dogru M, Baba F, Tomita M, Abe J, et al. The role of Staphylococcal enterotoxin in atopic keratoconjunctivitis and corneal ulceration. *Allergy* 2012;67: 799-803.
- Dougherty JM, McCulley JP. Tear lysozyme measurements in chronic blepharitis. *Ann Ophthalmol* 1985;17:53-7.
- Hogan DJ, Schachner L, Tanglertsampan C. Diagnosis and treatment of childhood scabies and pediculosis. *Pediatr Clin North Am* 1991; 8:941-57.
- Donaldson KE, Karp CL, Dunbar MT. Evaluation and treatment of children with ocular rosacea. *Cornea* 2007;26:42-6.
- Doan S, Chang P, Hoang-Xuan T. Conjunctival and lid inflammation in children. *Contemp Ophthalmol* 2009;8:1-8.
- Bernstein DJ, Gallagher JS, Grad M, Bernstein IL. Local ocular anaphylaxis to papain enzyme contained in a contact lens cleansing solution. *J Allergy Clin Immunol* 1984;74(3 Pt 1): 258-60.
- Boder E, Sedgwick RP. Ataxia-telangiectasia: a familial syndrome of progressive cerebellar ataxia, oculocutaneous telangiectasia and frequent pulmonary infection. *Pediatrics* 1958;21: 526-54.
- Harley RD, Baird HW, Craven EM. Ataxia-telangiectasia. Report of seven cases. *Arch Ophthalmol* 1967;77:582-92.
- Wong VW, Lai TY, Chi SC, Lam DS. Pediatric ocular surface infections: a 5-year review of demographics, clinical features, risk factors, microbiological results, and treatment. *Cornea* 2011;30:995-1002.
- Hessen M, Akpek EK. Ocular graft-versus-host disease. *Curr Opin Allergy Clin Immunol* 2012;12:540-7.
- Akerele T, Lightman S. Ocular complications in heart, lung and heart-lung recipients. *Br J Ophthalmol* 2007;91:310-12.
- Johnson DA, Jabs DA. The ocular manifestations of graft-versus-host disease. *Int Ophthalmol Clin* 1997;37:119-33.
- Bielory L. Update on ocular allergy treatment. *Expert Opin Pharmacother* 2002;3:541-53.
- Bielory L. Ocular allergy guidelines: a practical treatment algorithm. *Drugs* 2002;62:1611-34.
- Lemp MA. Contact lenses and associated anterior segment disorders: dry eye, blepharitis, and allergy. *Ophthalmol Clin North Am* 2003;16:463-9.
- Lemp MA, Bielory L. Contact lenses and associated anterior segment disorders: dry eye disease, blepharitis, and allergy. *Immunol Allergy Clin North Am* 2008;28:105-17.
- Lemp MA. Is the dry eye contact lens wearer at risk? *Yes. Cornea* 1990;9(Suppl. 1):S48-50, discussion S4.
- Hayes VY, Schneider CM, Veys J. An evaluation of 1-day disposable contact lens wear in a population of allergy sufferers. *Cont Lens Anterior Eye* 2003;26:85-93.
- Kari O, Haahela T. Is atopy a risk factor for the use of contact lenses? *Allergy* 1992;47(4 Pt 1): 295-8.
- Kari O, Teir H, Huuskonen R, Boström C, Lemola R. Tolerance to different kinds of contact lenses in young atopic and non-atopic wearers. *CLAO J* 2001;27:151-4.
- Bielory L, Meltzer EO, Nichols KK, Melton R, Thomas RK, Bartlett JD. An algorithm for the management of allergic conjunctivitis. *Allergy Asthma Proc* 2013;34:408-20.
- Spector SL, Raizman MB. Conjunctivitis medicamentosa. *J Allergy Clin Immunol* 1994;94: 134-6.
- Bielory L. Role of antihistamines in ocular allergy. *Am J Med* 2002;113(Suppl. 9A):34S-37S.
- Ciprandi G, Buscaglia S, Pesce GP, Marchesi E, Canonica GW, et al. Protective effect of loratadine on specific conjunctival provocation test. *Int Arch Allergy Appl Immunol* 1991;96: 344-7.
- Kjellman NI, Andersson B. Terfenadine reduces skin and conjunctival reactivity in grass pollen allergic children. *Clin Allergy* 1986;16: 441-9.
- Hingorani M, Lightman S. Therapeutic options in ocular allergic disease. *Drugs* 1995;50: 208-21.
- Butrus S, Portela R. Ocular allergy: diagnosis and treatment. *Ophthalmol Clin North Am* 2005;18:485-92, v.
- Abelson MB, Udell IJ. H2-receptors in the human ocular surface. *Arch Ophthalmol* 1981; 99:302-4.
- Jaanus SD. Oral and topical antihistamines: pharmacologic properties and therapeutic potential in ocular allergic disease. *J Am Optom Assoc* 1998;69:77-87.
- Sharif NA, Wiernas TK, Griffin BW, Davis TL. Pharmacology of [3H]-pyrilamine binding and of the histamine-induced inositol phosphates generation, intracellular Ca<sup>2+</sup>-mobilization and cytokine release from human corneal epithelial cells. *Br J Pharmacol* 1998; 125:1336-44.
- Yanni JM, Sharif NA, Gamache DA, Miller ST, Weimer LK, Spellman JM. A current appreciation of sites for pharmacological intervention in allergic conjunctivitis: effects of new topical ocular drugs. *Acta Ophthalmol Scand* 1999; 228(Suppl.):33-7.
- Tashiro M, Duan X, Kato M, Miyake M, Watanuki S, Ishikawa Y, et al. Brain histamine H1 receptor occupancy of orally administered antihistamines, bepotastine and diphenhydramine, measured by PET with 11C-doxepin. *Br J Clin Pharmacol* 2008;65:811-21.

59. Aguilar AJ. Comparative study of clinical efficacy and tolerance in seasonal allergic conjunctivitis management with 0.1% olopatadine hydrochloride versus 0.05% ketotifen fumarate. *Acta Ophthalmol Scand* 2000;78(Suppl. 230):52–5.
60. Scoper SV, Berdy GJ, Lichtenstein SJ, Rubin JM, Bloomenstein M, Prouty RE, et al. Perception and quality of life associated with the use of olopatadine 0.2% (Pataday) in patients with active allergic conjunctivitis. *Adv Ther* 2007;24:1221–32.
61. Galatowicz G, Ajayi Y, Stern ME, Calder VL. Ocular anti-allergic compounds selectively inhibit human mast cell cytokines in vitro and conjunctival cell infiltration in vivo. *Clin Exp Allergy* 2007;37:1648–56.
62. Beauregard C, Stephens D, Roberts L, Gamache D, Yanni J. Duration of action of topical antiallergy drugs in a guinea pig model of histamine-induced conjunctival vascular permeability. *J Ocul Pharmacol Ther* 2007;23:315–20.
63. Abelson MB, Gomes P, Crampton HJ, Schiffman RM, Bradford RR, Whitcup SM. Efficacy and tolerability of ophthalmic epinastine assessed using the conjunctival antigen challenge model in patients with a history of allergic conjunctivitis. *Clin Ther* 2004;26:35–47.
64. Kobayashi M, Kabashima K, Nakamura M, Tokura Y. Downmodulatory effects of the antihistaminic drug bepotastine on cytokine/chemokine production and CD54 expression in human keratinocytes. *Skin Pharmacol Physiol* 2009;22:45–8.
65. Andoh T, Kuraishi Y. Suppression by bepotastine besilate of substance P-induced itch-associated responses through the inhibition of the leukotriene B4 action in mice. *Eur J Pharmacol* 2006;547:59–64.
66. Kaminuma O, Ogawa K, Kikkawa H, Kikuchi M, Naito K, Ikezawa K. A novel anti-allergic drug, betotastine besilate, suppresses interleukin-5 production by human peripheral blood mononuclear cells. *Biol Pharm Bull* 1998;21:411–13.
67. Kato M, Nishida A, Aga Y, Kita J, Kudo Y, Narita H, et al. Pharmacokinetic and pharmacodynamic evaluation of central effect of the novel antiallergic agent betotastine besilate. *Arzneimittelforschung* 1997;47:1116–24.
68. Abelson MB, Torkildsen GL, Williams JI, Gow JA, Gomes PJ, McNamara TR, et al. Time to onset and duration of action of the antihistamine bepotastine besilate ophthalmic solutions 1.0% and 1.5% in allergic conjunctivitis: a phase III, single-center, prospective, randomized, double-masked, placebo-controlled, conjunctival allergen challenge assessment in adults and children. *Clin Ther* 2009;31:1908–21.
69. Bielory L, Duttachoudhury S, McMunn A. Bepotastine besilate for the treatment of pruritus. *Expert Opin Pharmacother* 2013;14:2553–69.
70. Tomioka H, Yoshida S, Tanaka M, Kumagai A. Inhibition of chemical mediator release from human leukocytes by a new antiasthma drug, HC 20-511 (ketotifen). *Monogr Allergy* 1979;14:313–17.
71. Nishimura N, Ito K, Tomioka H, Yoshida S. Inhibition of chemical mediator release from human leukocytes and lung in vitro by a novel antiallergic agent, KB-2413. *Immunopharmacol Immunotoxicol* 1987;9:511–21.
72. Grant SM, Goa KL, Fitton A, Sorkin EM. Ketotifen. A review of its pharmacodynamic and pharmacokinetic properties, and therapeutic use in asthma and allergic disorders. *Drugs* 1990;40:412–48.
73. Sabbah A, Marzetto M. Azelastine eye drops in the treatment of seasonal allergic conjunctivitis or rhinoconjunctivitis in young children. *Curr Med Res Opin* 1998;14:161–70.
74. Ciprandi G, Buscaglia S, Pesce G, Villaggio B, Bagnasco M, Canonica GW. Allergic subjects express intercellular adhesion molecule-1 (ICAM-1 or CD54) on epithelial cells of conjunctiva after allergen challenge. *J Allergy Clin Immunol* 1993;91:783–92.
75. Greiner JV, Edwards-Swanson K, Ingerman A. Evaluation of alcaftadine 0.25% ophthalmic solution in acute allergic conjunctivitis at 15 minutes and 16 hours after instillation versus placebo and olopatadine 0.1%. *Clin Ophthalmol* 2011;5:87–93.
76. Ono SJ, Lane K. Comparison of effects of alcaftadine and olopatadine on conjunctival epithelium and eosinophil recruitment in a murine model of allergic conjunctivitis. *Drug Des Devel Ther* 2011;5:77–84.
77. Friday GA, Biglan AW, Hiles DA, Murphey SM, Miller DL, Rothbach C, et al. Treatment of ragweed allergic conjunctivitis with cromolyn sodium 4% ophthalmic solution. *Am J Ophthalmol* 1983;95:169–74.
78. Kamei C, Izushi K, Tasaka K. Inhibitory effect of levocabastine on experimental allergic conjunctivitis in guinea pigs. *J Pharmacobiodyn* 1991;14:467–73.
79. Johnson HG, White GJ. Development of new antiallergic drugs (cromolyn sodium, lodoxamide tromethamine). What is the role of cholinergic stimulation in the biphasic dose response? *Monogr Allergy* 1979;14:299–306.
80. Leonardi A, Borghesan F, Avarello A, Plebani M, Secchi AG. Effect of lodoxamide and disodium cromoglycate on tear eosinophil cationic protein in vernal keratoconjunctivitis. *Br J Ophthalmol* 1997;81:23–6.
81. Santos CI, Huang AJ, Abelson MB, Foster CS, Friedlaender M, McCulley JP. Efficacy of lodoxamide 0.1% ophthalmic solution in resolving corneal epitheliopathy associated with vernal keratoconjunctivitis. *Am J Ophthalmol* 1994;117:488–97.
82. Nakagawa Y, Jikuhara Y, Higasida M, Yuasa T. [Suppression of conjunctival provocation by 0.1% pemirolast potassium ophthalmic solution in VKC]. *Arerugi* 1994;43:1405–8.
83. Yanni JM, Miller ST, Gamache DA, Spellman JM, Xu S, Sharif NA. Comparative effects of topical ocular anti-allergy drugs on human conjunctival mast cells. *Ann Allergy Asthma Immunol* 1997;79:541–5.
84. Gonzalez JB, Brogden RN. Nedocromil sodium: a preliminary review of its pharmacodynamic and pharmacokinetic properties, and therapeutic efficacy in the treatment of reversible obstructive airways disease. *Drugs* 1987;34:560–77.
85. Leino M, Carlson C, Jaanio E, Koivunen T, Lavikkala H, Riihelä K, et al. Double-blind group comparative study of 2% nedocromil sodium eye drops with placebo eye drops in the treatment of seasonal allergic conjunctivitis. *Ann Allergy* 1990;64:398–402.
86. Verin P. Treating severe eye allergy. *Clin Exp Allergy* 1998;28:44–8.
87. Verin PH, Dicker ID, Mortemousque B. Nedocromil sodium eye drops are more effective than sodium cromoglycate eye drops for the long-term management of vernal keratoconjunctivitis. *Clin Exp Allergy* 1999;29:529–36.
88. Wood TS, Stewart RH, Bowman RW, McCulley JP, Reaves TA Jr. Suprofen treatment of contact lens-associated giant papillary conjunctivitis. *Ophthalmology* 1988;95:822–6.
89. Abelson MB, Butrus SI, Weston JH. Aspirin therapy in vernal conjunctivitis. *Am J Ophthalmol* 1983;95:502–5.
90. Meyer E, Kraus E, Zonis S. Efficacy of antiprostaglandin therapy in vernal conjunctivitis. *Br J Ophthalmol* 1987;71:497–9.
91. Howes JF. Loteprednol etabonate: a review of ophthalmic clinical studies. *Pharmazie* 2000;55:178–83.
92. Tauber J, Raizman MB, Ostrov CS, Laibovitz RA, Abelson MB, Betts JG, et al. A multicenter comparison of the ocular efficacy and safety of diclofenac 0.1% solution with that of ketorolac 0.5% solution in patients with acute seasonal allergic conjunctivitis. *J Ocul Pharmacol Ther* 1998;14:137–45.
93. Dell SJ, Shulman DG, Lowry GM, Howes J. A controlled evaluation of the efficacy and safety of loteprednol etabonate in the prophylactic treatment of seasonal allergic conjunctivitis. Loteprednol Allergic Conjunctivitis Study Group. *Am J Ophthalmol* 1997;123:791–7.
94. Dell SJ, Lowry GM, Northcutt JA, Howes J, Novack GD, Hart K. A randomized, double-masked, placebo-controlled parallel study of 0.2% loteprednol etabonate in patients with seasonal allergic conjunctivitis. *J Allergy Clin Immunol* 1998;102:251–5.
95. Friedlaender MH, Howes J. A double-masked, placebo-controlled evaluation of the efficacy and safety of loteprednol etabonate in the treatment of giant papillary conjunctivitis. The Loteprednol Etabonate Giant Papillary Conjunctivitis Study Group I. *Am J Ophthalmol* 1997;123:455–64.
96. Bielory L, Mongia A. Current opinion of immunotherapy for ocular allergy. *Curr Opin Allergy Clin Immunol* 2002;2:447–52.
97. Alvarez-Cuesta E, Cuesta-Herranz J, Puyana-Ruiz J, Cuesta-Herranz C, Blanco-Quirós A. Monoclonal antibody-standardized cat extract immunotherapy: risk-benefit effects from a double-blind placebo study. *J Allergy Clin Immunol* 1994;93:556–66.
98. Donovan JP, Buckeridge DL, Briscoe MP, Clark RH, Day JH. Efficacy of immunotherapy to ragweed antigen tested by controlled antigen exposure. *Ann Allergy Asthma Immunol* 1996;77:74–80.
99. Ito Y, Takahashi Y, Fujita T, Fukuyama S. Clinical effects of immunotherapy on Japanese cedar pollinosis in the season of cedar and cypress pollination. *Auris Nasus Larynx* 1997;24:163–70.
100. Talymus Ophthalmic Suspension 0.1%, ClinicalStudyResults.org. 2009 [cited 2009 May 20]; Available from [http://www.clinicalstudyresults.org/drugdetails/viewfile.php?study\\_name=FJ-506D-AC09+summary&file=%2FDocuments%2Fcompany-study\\_8768\\_0.pdf](http://www.clinicalstudyresults.org/drugdetails/viewfile.php?study_name=FJ-506D-AC09+summary&file=%2FDocuments%2Fcompany-study_8768_0.pdf).
101. Vichyanond P, Tantimongkolsuk C, Dumrongkigchaiporn P, Jirapongsananuruk O, Visitsunthorn N, Kosriukvongs P. Vernal keratoconjunctivitis: result of a novel therapy with 0.1% topical ophthalmic FK-506 ointment. *J Allergy Clin Immunol* 2004;113:355–8.

102. Sperr WR, Agis H, Semper H, Valenta R, Susani M, Sperr M, et al. Inhibition of allergen-induced histamine release from human basophils by cyclosporine A and FK-506. *Int Arch Allergy Immunol* 1997;114:68–73.
103. Agostinis F, Foglia C, Landi M, Cottini M, Lombardi C, Canonica GW, et al. The safety of sublingual immunotherapy with one or multiple pollen allergens in children. *Allergy* 2008;63:1637–9.
104. Seasonal allergic rhinitis: limited effectiveness of treatments. *Prescrire Int* 2008;17:28–32.
105. Durham SR, Riis B. Grass allergen tablet immunotherapy relieves individual seasonal eye and nasal symptoms, including nasal blockage. *Allergy* 2007;62:954–7.
106. Bielory L. Ocular symptom reduction in patients with seasonal allergic rhinitis treated with the intranasal corticosteroid mometasone furoate. *Ann Allergy Asthma Immunol* 2008;100:272–9.
107. Origlieri C, Bielory L. Intranasal corticosteroids and allergic rhinoconjunctivitis. *Curr Opin Allergy Clin Immunol* 2008;8:450–6.
108. Bielory B, Bielory L. Over-the-counter migration of steroid use: impact on the eye. *Curr Opin Allergy Clin Immunol* 2014;14:471–6.
109. Mainardi T, Kapoor S, Bielory L. Complementary and alternative medicine: herbs, phytochemicals and vitamins and their immunologic effects. *J Allergy Clin Immunol* 2009;123:283–94, quiz 95–6.
110. Bielory L, Heimall J. Review of complementary and alternative medicine in treatment of ocular allergies. *Curr Opin Allergy Clin Immunol* 2003;3:395–9.



## KEY POINTS

- While true drug hypersensitivity is relatively uncommon, many children are labeled as being 'allergic' to various medications, particularly antibiotics. They end up carrying this label into adulthood and are likely to be treated with alternative antibiotics, which may be less effective, more toxic, more expensive and lead to the development and spread of certain types of drug-resistant bacteria.
- In children, the drugs most frequently involved in suspected drug hypersensitivity reactions are similar to those in the adult population:  $\beta$ -lactam antibiotics, non-steroidal antiinflammatory drugs, other antibiotics, acetaminophen/paracetamol and others.
- The entire spectrum of drug hypersensitivity reactions can be seen in children, even the most severe cutaneous and organ-specific types.
- Most of the lessons learnt from drug hypersensitivity reactions in adults can be and have been extrapolated and applied to the pediatric population. However, some peculiarities arise in children in terms of prevalence and involved classes as well as practical aspects of the drug allergy work-up.
- Certain approaches such as simplifying and reducing the protocol steps in highly selected pediatric populations seem increasingly attractive to groups working in pediatric settings. It remains to be seen whether they will stand the test of time and be accepted as a general rule in drug allergy work-up in children.

## Introduction

Drug hypersensitivity reactions (DHRs) are adverse effects of pharmaceutical formulations (including active drugs and excipients) that clinically resemble allergy.<sup>1</sup> Iatrogenic by nature, drug allergy goes against the ultimate purpose of prescribing a drug, which is to alleviate, and not to induce a disease. DHRs represent a public health problem whose burden arises from:

- misdiagnosis: both underdiagnosis (due to under-reporting<sup>2,3</sup>) and overdiagnosis (due to an over-use of the term 'allergy', e.g. in the presence of symptoms due to co-existing factors such as infections<sup>2,4</sup>);
- prevalence: affecting more than 7% of the general population;<sup>2</sup>
- misbeliefs: not only is the suspicion of DHRs long lasting, with patients carrying the 'allergy' label into adulthood, but the field of DHRs must be one of the very few in medicine where the suspicion of a condition may persist even after the diagnosis has been discarded with the best available means.<sup>5,6</sup>

The work of numerous groups dealing with DHR management has provided a growing body of evidence leading to guidelines and/or consensus documents to support medical decision making on several aspects of DHR. These documents vary in scope and methodology in that they: (1) are national,<sup>7-11</sup> regional, or international;<sup>12-23</sup> (2) concern one specific drug class;<sup>8,9,15-17,19,21,22,24</sup> (3) focus specifically on evaluation tools/management;<sup>12-14,18,20,24,25</sup> or (4) are more general.<sup>7,9,26,27</sup> Recently, the International Collaboration in Asthma, Allergy and Immunology (iCAALL)<sup>28</sup> contributed to the issue of an International Consensus (ICON) on drug allergy,<sup>29</sup> a comprehensive reference aimed at highlighting the key messages that are common to the existing guidelines, while critically reviewing and commenting on any differences. As for the ICON on pediatric asthma,<sup>30</sup> unmet needs, research and guideline update recommendations were generated.

Most of the lessons learnt from DHR in adults have been extrapolated and applied to the pediatric population. However, some peculiarities arise in terms of prevalence and involved classes as well as practical aspects of drug allergy work-up. For instance, a shorter algorithm of testing has been recently proposed by some groups in highly selected pediatric patients with a suspicion of  $\beta$ -lactam (BL) allergy. Nevertheless, there are hardly any specific recommendations for the pediatric population. Currently, a Task Force on Paediatric Drug Allergy is ongoing within the European Academy of Allergy and Clinical Immunology (EAACI) drug allergy interest group (DAIG) and its core group, the European Network of Drug Allergy (ENDA).

Clinicians and researchers working in the field of DHR are aware that there is a risk of iatrogenesis in subjects with histories that suggest, but do not always confirm, DHR. Proper identification of a DHR, and all the steps leading to it, upholds the principle of '*primum non nocere*'.

Due to space limitation, the entire spectrum of DHRs cannot be addressed and, for this, the reader is referred to the previously mentioned guidelines. This chapter will focus on the most clinically relevant reactions: to antibiotics, aspirin (acetylsalicylic acid; ASA) and other nonsteroidal antiinflammatory drugs (NSAIDs) and vaccines. There is an emphasis on novel approaches in drug allergy work-up in children.

## Epidemiology

Patients and physicians commonly refer to all adverse drug reactions (ADRs) as being 'allergic'. This causes confusion and misconception with regards to drug hypersensitivity. Drugs can indeed induce several different types of immunologic reactions that, together with nonallergic DHRs, comprise 15% of all ADRs.<sup>29</sup> Nonallergic DHRs resemble allergy, but have no proven immunologic mechanism.

While true DHR is relatively uncommon, many children are labeled as being 'allergic' to various medications, particularly

antibiotics such as penicillins (or more widely, BL). They end up carrying this label into adulthood. These patients are more likely to be treated with alternative antibiotics, which may be less effective, more toxic, more expensive and lead to the development and spread of certain types of drug-resistant bacteria.

Estimates of the prevalence of DHR in the pediatric population vary widely between studies. Recent cross-sectional surveys revealed that the incidence of self-reported DH ranged between 2.5% and 10.2% of children.<sup>31</sup>

A systematic review and meta-analysis<sup>32</sup> concluded that the overall incidence of ADRs in hospitalized children was 9.5%, and that for outpatient children it was 1.5%. A large study from the USA found that the overall incidence of self-reported antibiotic allergy was 15.3%, and that increasing age had a significant correlation with antibiotic allergy prevalence.<sup>33</sup> Nonetheless, these data are based on studies that, in most cases, have addressed ADRs in general, ignoring the underlying mechanism. Indeed, a study on children in Portugal<sup>34</sup> highlighted the fact that although ADRs were frequently reported in an outpatient pediatric survey (10.2%), after a complete evaluation very few (4.5%) of these reactions could be attributed to DHRs.

It is assumed that in children most skin reactions are attributable to infectious diseases or interactions between drugs and infectious agents rather than to the drugs themselves.<sup>35–37</sup>

Whether or not children carry a drug hypersensitivity into adulthood is not known; there are no follow-up studies addressing this aspect of the natural history of DHRs. While there is little or no evidence regarding nonallergic DHRs, we do have some insight with respect to allergic DHRs: the IgE response (to BL) is known to decrease with time (in adults),<sup>38</sup> while T cell mediated response is long lasting.<sup>19,39</sup> Proven DHR seems to be less common in children compared with adults. However, the validity of a negative drug allergy work-up performed in adults who have had a reaction suggesting drug hypersensitivity in

childhood can be questioned because of the time that has elapsed since the occurrence of the reaction. In a study involving 3,275 patients, Rubio and colleagues<sup>40</sup> reported that when the first reaction occurred during childhood, the prevalence rate of positive tests was similar whether the test was carried out during childhood (10.6%) or adulthood (10.6%). It could be therefore extrapolated that drug hypersensitivity in childhood does not resolve with time, although prescription habits have dramatically changed over the last 20 years, with increasing use of antibiotics in particular.

In children, the drugs most frequently involved in suspected DHRs are similar to those in the adult population: BL antibiotics, NSAIDs, other antibiotics, acetaminophen/paracetamol and local anesthetics.<sup>40</sup>

## Clinical Manifestations

Drug hypersensitivity reactions are classified artificially into two types, according to the delay in onset of the reaction after the last administration of the drug: (1) immediate reaction, occurring less than 1 hour after the last drug intake, and (2) non-immediate reaction, with variable cutaneous symptoms occurring after more than 1 hour and up to several days after the last drug intake.

The entire spectrum of DHRs (Table 55-1) can be seen in children, even the most severe cutaneous and organ-specific types.<sup>41,42</sup>

## Drug Allergy Work-Up

### EVALUATION OF THE CLINICAL HISTORY

The suspicion of DHR arises from several factors elicited from the clinical history. The following details should be

TABLE 55-1

Classification of Drug Allergies

Type	Type of Immune Response	Pathophysiology	Clinical Symptoms	Typical Chronology of the Reaction
I	IgE	Mast cell and basophil degranulation	Anaphylactic shock Angioedema Urticaria Bronchospasm	Within 1–6 hours after the last intake of the drug
II	IgG and complement	IgG and complement-dependent cytotoxicity	Cytopenia	5–15 days after the start of the eliciting drug
III	IgM or IgG and complement or FcR	Deposition of immune complexes	Serum sickness Urticaria Vasculitis	7–8 days for serum sickness/urticaria 7–21 days after the start of the eliciting drug for vasculitis
IVa	Th1 (IFN $\gamma$ )	Monocytic inflammation	Eczema	1–21 days after the start of the eliciting drug
IVb	Th2 (IL-4 and IL-5)	Eosinophilic inflammation	Maculopapular exanthem (MPE), DRESS	1 to several days after the start of the eliciting drug for MPE 2–6 weeks after the start of the eliciting drug for DRESS
IVc	Cytotoxic T cells (perforin, granzyme B, FasL)	Keratinocyte death mediated by CD4 or CD8	Maculopapular exanthem, SJS/TEN, pustular exanthem	1–2 days after the start of the eliciting drug for fixed drug eruption 4–28 days after the start of the eliciting drug for SJS/TEN
IVd	T cells (IL-8/CXCL8)	Neutrophilic inflammation	Acute generalized exanthematous pustulosis	Typically 1–2 days after the start of the eliciting drug (but could be longer)

DRESS – Drug reaction with eosinophilia and systemic symptoms; SJS – Stevens-Johnson syndrome; TEN – toxic epidermal necrolysis.

(With permission from Demoly P, Adkinson NF, Brockow K, Castells M, Chiriac AM, Greenberger PA, et al. *International Consensus on drug allergy*. *Allergy* 2014;69(4):420–37.)

**TABLE 55-2**  
**Severity/Danger Signs in Drug Hypersensitivity Reactions**

	Visible Severity Signs	Invisible Severity Parameters
<b>Immediate reactions</b>	Sudden onset of multisystem symptoms (respiratory, skin and mucosal) Reduced blood pressure Dyspnea Dysphonia Sialorrhoea	High levels of serum tryptase*
<b>Non-immediate reactions</b>	General Lymphadenopathy Fever > 38.5°C Organ specific  Painful skin Skin extension > 50%  Atypical target lesions Erosions of mucosa Skin blisters, bullae Centrofocal edema Purpuric infiltrated papules, cutaneous necrosis	Changes in blood count† Cytopenia Eosinophilia Alteration of liver function tests†  Alteration of kidney function†

\*No clinical utility in the acute setting.

†If a severe delayed DHR is suspected, all patients should have complete blood count and liver and kidney function tests.

(With permission from Chiriac AM, Demoly P. *Drug allergy diagnosis. Immunol Allergy Clin North Am* 2014;34:461-71.)

addressed: (1) the timing of the reaction (with respect to drug administration), (2) the nature of the drugs involved, (3) the history of a previous exposure to the same drug or to cross-reactive drugs, (4) the medical/genetic background, (5) the circumstances of the occurrence of the reaction and (6) differential diagnosis.<sup>29</sup> If possible, these details should be compiled in a standardized manner.<sup>12</sup> Documentation of the presence of severity signs (Table 55-2) is mandatory since they will tailor the drug allergy work-up and establish contraindications to re-exposure.

## SKIN TESTS

### General Aspects of Skin Tests

Skin tests are the first step in in vivo re-exposure to the drug, and are therefore of utmost importance. If positive at validated, nonirritant concentrations, they confirm the diagnosis of sensitization to the culprit and/or cross-reactive drugs and avoid the need for a drug provocation test (DPT). The tests should follow standard operating procedures and should be performed by personnel trained in their practice and interpretation. They have to be applied according to the suspected pathogenetic mechanism of the DHR, with immediate and/or late-reading prick tests and intradermal tests according to the initial clinical presentation (patch tests can also be used to explore delayed DHRs, but late-reading intradermal tests are preferred whenever possible, because of their demonstrated higher sensitivity for BL in adults).<sup>19</sup> The diagnostic value of skin tests is limited by several factors:

1. They only address true allergic reactions, providing evidence for type I and type IV drug allergies.
2. For most drug allergens, standardized and validated test concentrations and vehicles have not been elucidated. The European Network of Drug Allergy/Drug Allergy Interest Group (ENDA/DAIG) network took on the task of reviewing the literature for evidence to support the recommendation of specific appropriate drug concentrations for systemically administered drugs. Their conclusions and recommendations have recently been published.<sup>23</sup>
3. Sometimes the drug is not available in an adequately reactive form (generally because it is a metabolic derivative that is immunogenic and not the parent drug).

### Peculiar Aspects of Skin Tests in Children

The pain of intradermal tests may limit their use in young children and, in the absence of therapeutic necessity, a 'waiting approach' is generally adopted until the patient is older. On the other hand, viral infections are thought to be the most common cause of maculopapular or urticarial eruptions in children<sup>36</sup> and this hypothesis is strongly favored after a negative drug allergy work-up. With these two considerations in mind, a shorter algorithm of testing, i.e. bypassing skin tests, in highly selected pediatric patients has been proposed by some groups. In the first prospective study of its kind, Caubet et al<sup>36</sup> performed DPT in 88 children with benign delayed eruptions (maculopapular exanthema or urticaria) to BL antibiotics, irrespective of skin test results. The lack of any criteria of severity had been confirmed by a trained allergist in the acute phase of the reaction. Six out of 88 children (6.8%) had a positive DPT (4 of them also had immediate positive intradermal tests but, interestingly, none had positive patch tests or delayed-reading intradermal tests). The authors found that the group with positive intradermal tests did have a significantly higher rate of positive DPT ( $P < .05$ ), but that none of the 6 patients with a positive DPT developed a more severe reaction than the index event. They thus concluded that skin tests had a limited value in the diagnosis of these benign cutaneous eruptions in children and suggested performing DPT without previous skin testing in these selected patients.

## DRUG PROVOCATION TESTS

### General Aspects of Drug Provocation Tests

The DPT is performed at the end of a stepwise approach in the drug allergy work-up. There is general agreement that this procedure has better sensitivity than all the other available diagnostic tools, and that it may considerably improve patient management. However, its use as the 'gold standard' to establish (or exclude) the diagnosis of DHR is not unanimously accepted or widespread in the medical community, due to its inherent risks. Interestingly, however, a study carried out in three European centers dealing with the patient's perspective and satisfaction with regard to DPT revealed that most patients accepted DPT for diagnostic purposes, irrespective of the final test results. Furthermore, 95% of them believed that it was useful and stated that they would recommend it to others.<sup>43</sup> Similar findings were observed across other centers, in adults as well as in children.

Although not well established, the negative predictive value (NPV) of DPTs is important for both the patient and the physician. One of the main limitations of DPT is that a negative test

does not prove beyond any doubt tolerance for the drug in the future, but rather that there is no DHR at the time of the test. Studies regarding the NPV of DPTs are, however, encouraging and display virtually the same results in both adult and pediatric populations. A high NPV of BL DPT of 94% to 98% was found in a large study involving 256 children,<sup>44</sup> and most of the reactions reported by the patients were mild and non-immediate. This information should reassure the patients and their doctors about prescription of drugs after negative DPT.

General considerations on DPTs, with regard to indications, contraindications, methods, limitations and interpretation, have been thoroughly addressed<sup>14</sup> and protocols published.<sup>4,15,16,19,45</sup> Nevertheless, the precise DPT procedure may vary considerably from one team to the next. Moreover, in pediatric settings, novel approaches arise, awaiting either validation or refutation by larger studies in the future.

### *Particular Aspects of Drug Provocation Testing in Children*

**(1) Methodology of DPT.** Technical aspects vary between published studies in terms of initial dose, number of and interval between protocol steps, and duration of DPT. In a child with negative testing and in the absence of contraindications, drug hypersensitivity should be ruled out or confirmed by administering an age- and weight-appropriate cumulative dose of the drug to which the patient initially reacted. An observation period should then follow, before discharging the child, in order to ensure that no life-threatening reaction occurs. Informed consent should be obtained (ideally from both parents).

A maximum single dose of the specific drug must be achieved and the administration of the defined daily dose is desirable.

**(2) Duration of the DPT.** Depending on the type of the drug itself, the severity of the DHR under investigation and the expected time latency between application and reaction, the DPT may take hours, days or, occasionally, weeks before it is complete.<sup>14</sup>

There is controversy among different groups as to whether one full therapeutic dose (of the tested drug) is sufficient to elicit reactions in non-immediate responders, particularly in children. Hence, prolonged<sup>36,46</sup> courses have been suggested to increase the sensitivity of DPTs. However, this suggestion is still subject to debate and must be considered with caution in terms of diagnostic improvement, cost and medical implications.

Another matter for discussion concerning non-immediate reactions is the duration of the DPT, and also, for some authors, the location. Theoretically, DPT should be performed in the hospital, under medical supervision. In the study of Ponvert et al,<sup>46</sup> DPTs were carried out either in a hospital setting (for immediate reactors) or at home (for a group of children with a clinical history of mild to moderately severe non-immediate reactions). The latter group was prescribed the daily therapeutic dose for up to 10 days, according to the chronology of the index reaction. Eighty-eight reactions were reported for DPT performed at home, accounting for 6.1% of the 1,431 tested patients. One urticaria with asthma exacerbation and two severe serum sickness-like reactions (SSLR) were elicited by DPT performed at home.

**(3) Step Dosing.** Based on their initial results in the prospective study of 88 children with benign delayed cutaneous reactions during BL treatment (challenged irrespective of skin

test outcome), Caubet et al<sup>36</sup> concluded that, in these patients, performing a single-dose DPT can be considered safe. The group is currently generating data with this practice (single-dose protocol, followed by 30-minute observation). The authors emphasize that this procedure requires careful primary evaluation by an experienced allergist and cannot be performed in patients suspected of having a more severe reaction. Such a level of certainty about the initial reaction history is only possible if the clinician has observed the reaction first hand, or if there is clear documentation of the reaction in the medical record. Otherwise, in case of doubt, the group recommends performing a complete drug allergy work-up, including skin testing, prior to a more progressive DPT.

Other authors have also performed DPT with or without skin testing. Chambel et al<sup>47</sup> implemented this practice and reported a 6-year experience of drug allergy work-up in children with clinical histories of either immediate or delayed reactions to BL antibiotics. However, in this study, patients with positive skin tests were not challenged, and in about one third of the patients (32 out of 114, 28%) who underwent DPT directly, an alternative cross-reactive drug was used. Of the 68 patients not skin tested to BL and submitted to a DPT with the culprit antibiotic, almost two thirds (62.5%) could not specify the chronology of the initial reaction. In this study, there were more DPT reactors in the subgroup with immediate index reactions than in the delayed-type reaction group (36.4% vs 16.9%). Conversely, there were more DPT negative patients in the delayed group (19.7% vs 9% who had presented immediate reactions in their clinical history), although this difference did not reach statistical significance in simple univariate analysis.

Regarding these practices (bypassing skin testing, single-dose DPT), no recommendation has been issued by the national or international allergology societies. A growing body of evidence regarding (1) standardization of the various protocols, (2) precise identification of the selected pediatric patients that could benefit from it, and (3) safety profile must be provided before its possible acceptance and adoption as a standard practice in the diagnosis of BL allergy in children.

**(4) DPT Contraindications.** Drug provocation testing should never be performed on patients who have experienced severe, life-threatening immunocytotoxic reactions, vasculitic syndromes, exfoliative dermatitis, erythema multiforme major/Stevens-Johnson syndrome, drug-induced hypersensitivity reactions (with eosinophilia)/DRESS, toxic epidermal necrolysis or organ involvement. In a large retrospective study regarding BL allergy in children, Ponvert et al<sup>46</sup> suggested that SSLR, erythema multiforme and Stevens-Johnson syndrome in children are mainly due to viral infections and that in such patients, with a negative allergologic work-up based on late-reading intradermal and patch tests, DPT might be considered for essential (future necessity) BL. However, this course of action must be regarded with the utmost caution, given that supporting evidence is lacking and due to the high risk of recurrence of such reactions.<sup>48</sup>

## DESENSITIZATION

In order to confirm or rule out DHR, elective testing, i.e. performing a drug allergy work-up in children labeled 'allergic' to important drugs (BL, NSAIDs, local anesthetics), is always preferred to testing during situations of acute need. However, in



cases where testing could not be performed before the situation that required therapeutic administration, and in the absence of contraindication, desensitization is an option. Referral to successfully applied existing protocols is recommended because there are no generally accepted protocols for drug desensitization in immediate DHRs.<sup>20,29</sup> For non-immediate DHRs the literature is more controversial and desensitization should be restricted to uncomplicated exanthems or fixed drug eruption, due to the unpredictability and limited therapeutic options in severe DHRs.<sup>25</sup>

## Beta-lactam Antibiotics

Beta-lactam antibiotic DHRs are explored as described above, by a thorough clinical history, standardized skin tests, and DPTs if necessary.

There is still an ongoing debate on whether to recommend a fixed panel of haptens to be included in the diagnostic evaluation of BL allergy due to: (1) different experiences, (2) different drug prescription habits and (3) different patterns of sensitization (which certainly follow past and present patterns of antibiotic use). However, classically, a certain number of reagents are considered to be essential for the diagnosis of BL allergy. The current recommended reagents used for skin testing<sup>7,19</sup> comprise, when available, a combination of PPL (the penicillin major determinant benzylpenicilloyl conjugated to poly-L-lysine), MDM (mixture of minor determinants), and/or penicillin G (in cases of unavailability of PPL/MDM or if skin tests to PPL/MDM are negative) in addition to the suspected determinants that bring their side-chain structures into the panel (i.e. amoxicillin and culprit drugs such as cephalosporins). Of note, a few recent reports pointed out the role of selective clavulanic acid hypersensitivity in reactions attributed to the combination of amoxicillin and clavulanic acid.<sup>49</sup> Selective immediate and delayed-type DHRs to clavulanic acid were diagnosed based on positive skin tests (or DPT) with amoxicillin associated with clavulanic acid, whereas skin tests (and DPT) with amoxicillin remained negative. Some authors<sup>49,50</sup> performed skin tests with purified clavulanic acid alone (the drug is unstable in solution, requiring the use of excipients and limiting its availability) and obtained positive results at concentrations that proved negative in exposed controls. In the largest retrospective study to date on BL allergy in children (1,431 patients evaluated over a 20-year period), Ponvert et al<sup>46</sup> observed that up to 37 of the 87 (42.5%) children diagnosed as hypersensitive (by means of positive DPT) to combined amoxicillin/clavulanic acid were actually selective responders to the latter and tolerated amoxicillin. However, in another large pediatric European study, tackling immediate drug hypersensitivity reactions to penicillins and cephalosporins in 1,170 children,<sup>51</sup> no such case was mentioned.

Beta-lactam skin tests have been used for decades and systemic reactions (ranging from generalized cutaneous reactions to anaphylactic shock, including a few cases of fatalities) have been described, especially in relation to IgE-mediated allergy. In a predominantly adult population, the prevalence of such reactions was up to 8.8% to 9.4% of the positive skin-tested patients (1.2–1.3% of the tests).<sup>52,53</sup> The safety of skin tests to BL in children appears to be better, with an overall prevalence ranging between 0 and 1.2%<sup>51,54</sup> of the tested patients and 2.6% and 3.8% of the allergic children.<sup>46,54</sup>

The prevalence of BL DHR varies greatly between large series, from 7.92%<sup>55</sup> to 58.3%.<sup>51</sup> As with adults, skin tests are of

greater diagnostic value in confirming immediate rather than delayed-type DHR to BL, with a sensitivity ranging from 86%<sup>46</sup> for the former to 3.77%<sup>55</sup> for the latter. Overall, most of the cases, whether immediate or non-immediate, are confirmed by DPT.<sup>46,55</sup>

Some groups focussed on the use of specific BL in particular pediatric settings, i.e. in patients suffering from cystic fibrosis.<sup>56–59</sup>

## Non- $\beta$ -lactam Antibiotics

Children suspected of having DHRs for antibiotics other than BL are not generally subjected to elective testing. The attitude most frequently adopted by physicians is definitive avoidance, mainly because these drugs are rarely used as a first-line treatment. Apart from BL, the two antibiotic classes most commonly involved in pediatric DHRs are sulfonamides and macrolides.<sup>37,60</sup> Because they are not systematically studied, the bulk of the data derives from case reports, case series or studies in specific populations (i.e. HIV-infected subjects for sulfonamides). Moreover, the true prevalence of DHRs to these antibiotics is difficult to determine due to certain issues interfering with the drug allergy work-up:

1. The lack of standardized, nonirritating concentrations for skin tests, most of the diagnosis relying therefore upon DPTs.
2. The relative use of DPT as a diagnostic procedure, because of alternative approaches:
  - a. for macrolides, the use of an alternative drug, as a matter of principle in most cases, without prior confirmation of DHRs to the culprit macrolide
  - b. for sulfonamides, the use of desensitization for therapeutic purposes.

## SULFONAMIDES

Antibacterial sulfonamides (sulfamethoxazole, sulfadoxine and sulfapyridine) – which are derivatives of sulfanilamides – are of allergenic importance. Patients with an allergy to a sulfanilamide might cross-react with other sulfanilamides with a different side chain, but not with sulfonamides in general.<sup>61</sup> Although they can induce a broad spectrum of DHRs (including type I and type II allergies, i.e. hemolytic anemia), they are known and feared elicitors of severe cutaneous adverse reactions (SCARs) such as DRESS, Stevens-Johnson syndrome and toxic epidermal necrolysis. The drug allergy work-up obeys the general rules, but with a few peculiarities:

1. Positive skin tests have been described<sup>61</sup> but their sensitivity is low and certain groups support the use of in vitro tests (the lymphocyte transformation test) to increase sensitivity (with the advantage of using compounds that are not available for in vivo testing).
2. In a clinical situation requiring treatment and in the absence of contraindications, desensitization has been an option for many years (it is extensively used in the HIV-infected population) and protocols have been published.<sup>25,62</sup>

## MACROLIDES

Macrolide antibiotics are considered to be one of the safest antibiotic treatments available, with a DHR prevalence of 0.4% to 3% of all treatments.<sup>45,63</sup> Their chemical structure is

characterized by a large lactone ring, which can vary from 12 to 16 atoms, with one or more sugar chains attached. Cross-reactivity among different macrolides has not been extensively studied, but when it was tested, a majority of patients with a demonstrated DHR to a certain macrolide could tolerate another macrolide with a different number of atoms in the lactone ring. Moreover, macrolide antibiotics are unlikely to cross-react with macrolide immunosuppressants such as 23-C tacrolimus and 29-C sirolimus. Published series reveal that, after performing DPT, DHRs to macrolides are confirmed in only 2.7% to 17% of cases.<sup>45,63</sup>

## Nonsteroidal Antiinflammatory Drugs (NSAIDs)

Together with BL, NSAIDs are the most common elicitors of DHRs in children, as well as in adults.

Some considerations are worth mentioning with regard to the pediatric population:

1. The infrequent use of acetyl salicylic acid (ASA) because of concerns about Reye's syndrome in children.
2. The use of NSAIDs that are known to be generally well-tolerated alternatives in adults is regulated by prescription restrictions. Nimesulide was removed from the market in several countries due to concerns about hepatic ADRs, and oxicams and coxibs are only approved for children older than 15 years and adults, respectively.

Five major clinical entities are recognized in the new nomenclature proposed by the EAACI<sup>64</sup> although overlaps may exist: (1) NSAID-exacerbated respiratory disease (NERD); (2) NSAID-exacerbated cutaneous disease (NECD), (3) NSAID-induced urticaria/angioedema (NIUA); (4) single NSAID-induced urticaria/angioedema or anaphylaxis (SNIUAA); (5) NSAID-induced delayed hypersensitivity reactions (NIDHR). These entities underpin two reactive patterns: the cross-reactive types (1, 2 and 3), or cross-intolerant (CI), involving nonallergic mechanisms, and the single drug-induced types (4 and 5), presumably allergic in nature, involving putative IgE and T cell mediated mechanisms.

Several studies have confirmed that isolated angioedema is the most common manifestation of confirmed NSAID DHRs in children, with ibuprofen being the most frequently involved drug in the clinical history,<sup>55,65</sup> as well as in proven NSAID DHRs.

As with adults, the diagnosis is mainly based on clinical history and DPT. For nonallergic type 1–3 DHRs, neither skin nor laboratory tests are of value. However, for patients experiencing type 4 and 5 allergic reactions, skin tests and some *in vitro* tests can be of value, although with limitations.

Some authors perform ASA challenge, in order to confirm or discard cross-reactive status, in patients whose clinical history is not reliable, *i.e.* patients who developed a reaction with 1 or 2 NSAIDs. However, when challenged with ASA, ibuprofen-sensitive children reacted faster and at a lower total cumulative dose, and occasionally with more severe reactions (including respiratory symptoms such as rhinoconjunctivitis and also asthma) than their index reactions.<sup>55</sup>

Corzo *et al*<sup>66</sup> studied paracetamol and etoricoxib tolerance in 41 children with DHR (proven by means of DPT) to ASA and ibuprofen and found that all of them tolerated these

alternative drugs. All but two patients had clinical histories of NIUA (83.3% with angioedema). When challenged with meloxicam, only two patients (4.9%) reacted. The authors concluded that there was better tolerance to these drugs than in the adult NSAID hypersensitive population.<sup>67</sup> However, it cannot be ruled out that, in the natural evolution of NSAID DHR, reactions to these drugs may appear in initially tolerant children. Moreover, although their results indicate that paracetamol can be a safe alternative in these children, the authors underline that this needs to be verified by a DPT, because the estimated reaction to paracetamol varies in other studies and may be as high as 40%.<sup>65,68,69</sup> This high cross-reactive rate was found in a pediatric study (carrying the pitfall of a smaller sample size with only a few DPTs to find safe alternatives), where the tolerability rate for nimesulide was 88.8%.<sup>65</sup>

The clinical phenotype of NERD is less common in children. Reactions to COX-1 inhibitors can be life-threatening.<sup>70</sup>

## Vaccines

Vaccines are complex preparations and hold a special place in preventive medicine by generating a protective immune response against various infectious diseases. Withholding vaccination from patients with histories of possible or even confirmed DHRs to any component of the culprit vaccine may result in significant individual and social consequences because of the need for vaccination coverage of the population. Generally, the risks of vaccinating are outweighed by the risks of not vaccinating.<sup>8,71</sup> Given these considerations, as well as the growing body of evidence about the rarity of true DHRs to vaccines, recommendations regarding the re-administration of vaccines to a patient with a clinical history are somewhat different and more critical than in other areas of DHR.

Allergic-like reactions elicited by vaccines can be attributed to the microbial components, the residual components of the culture medium or the preservatives, stabilizers and adjuvants added to the vaccines.<sup>71</sup> Both food (gelatin, egg) and drug (*i.e.* neomycin, gentamicin, polymyxin B and streptomycin) hypersensitivities must be considered when evaluating vaccine DHRs. Local reactions are by far the most frequent adverse event after immunization, whereas systemic reactions (either immediate or non-immediate) occur with an estimated incidence ranging between 1 and 3 reactions per million vaccine doses.<sup>72,73</sup> Systemic reactions carry the risk of life-threatening anaphylaxis if the patient is re-exposed. Drug allergy work-up is therefore mandatory before the patient is re-exposed.

Vaccination is subject to immunization schedules but 'catch-up' booster doses can be administered to children whose vaccination has been delayed due to a suspicion of DHR. If skin testing, especially intradermal testing, to the vaccine itself is unreliable (because it may cause false and clinically irrelevant positive reactions), measuring levels of IgG antibodies to the immunizing agents in a vaccine suspected of causing a serious DHR can be considered as a step in the drug allergy work-up in these patients.<sup>8,71</sup> Determining whether or not they are at protective levels can help to determine whether subsequent doses of the vaccine are required. If the patients reach the established level associated with protection from disease, consideration can be given to withholding additional doses, although the induced immunity might be lower than if all doses were injected. Follow-up of levels of protection is then recommended.

## DIAGNOSIS AND MANAGEMENT OF A PATIENT WITH A CLINICAL HISTORY OF LOCAL REACTION AFTER VACCINE ADMINISTRATION

Patients developing local reactions after vaccine administration do not have a higher rate of systemic reactions upon re-exposure, so tests are not usually needed except in patients with a large local inflammatory reaction. If there is a suspicion of Arthus reaction, measurement of serum vaccine-specific antibodies (IgM/IgG) is indicated in order to detect a hyperimmunized status.

Patch tests can be useful in patients developing eczema or persistent nodules after vaccine administration. They can demonstrate a delayed DHR to preservatives or adjuvants and guide the physician to avoid vaccines and other products containing these incriminated components. However, a positive patch test is not accurate for the purpose of assessing a patient's ability to tolerate a vaccine and is not a contraindication to administering the vaccine following a risk-benefit analysis.<sup>8</sup> There are no contraindications for booster injections in relevant infectious agent seronegative subjects, even if they are aluminum or thimerosal patch test positive.<sup>8,71</sup>

## GENERAL MANAGEMENT OF PATIENTS WITH A HISTORY OF SYSTEMIC REACTION TO VACCINES

In children with systemic reactions, skin testing (and/or specific IgE) to the vaccine itself but also to the potential single components that may have caused the reaction (when commercially available) is required. Although the sensitivity and specificity of skin tests with the vaccine itself have not been studied, and false-positive reactions occur, the result can guide the approach. Patients with negative skin tests can receive the full dose of vaccine, while in patients with positive skin tests to the vaccine itself (or with confirmed allergy to one of its components) the ratio between risk and therapeutic benefit should be assessed

(including measurement of protective antibody levels) and the physician should determine whether subsequent doses of the suspected vaccine, or other vaccines with similar components, are required. If needed, the vaccine can still be administered following the protocol proposed by the American Academy of Pediatrics.<sup>8</sup>

## Multiple Drug Hypersensitivity Syndrome

About one third of the patients seen in a drug allergy consultation report multiple drug allergies.<sup>51,74</sup> True multiple drug hypersensitivity syndrome (MDH), as opposed to self-reported MDH, is rare and has been estimated in the range of 0.3% to 0.6% in large series of patients presenting with a suspicion of DHR.<sup>74,75</sup> However its incidence is definitely higher in delayed-type reactions, including SCARs.<sup>76,77</sup> Interestingly, although the prevalence of proven DHR in children is lower than in adults, Atanaskovic-Markovic et al<sup>51</sup> reported MDH in 7 of 279 children (2.5%) evaluated for suspected DHR over a 5-year period. In this series, one patient had a history of SCAR, namely SJS.

## Conclusions

Drug allergy work-up in children faces the same issues, challenges and unmet needs as in adults. Certain approaches (e.g. simplifying and reducing the protocol steps in highly selected pediatric populations) seem increasingly attractive to the groups working in pediatric settings. It remains to be seen whether they will stand the test of time and be accepted as a general rule in drug allergy work-up in children.

The complete reference list can be found on the companion Expert Consult website at <http://www.expertconsult.inkling.com>.

## KEY REFERENCES

- Ponvert C, Weilenmann C, Wassenberg J, Walecki P, Bourgeois ML, de Blic J, et al. Allergy to betalactam antibiotics in children: a prospective follow-up study in retreated children after negative responses in skin and challenge tests. *Allergy* 2007;62:42–6.
- Demoly P, Adkinson NF, Brockow K, Castells M, Chiriac AM, Greenberger PA, et al. International Consensus on drug allergy. *Allergy* 2014; 69:420–37.
- Caubet JC, Kaiser L, Lemaitre B, Fellay B, Gervaix A, Eigenmann PA. The role of penicillin in benign skin rashes in childhood: a prospective study based on drug rechallenge. *J Allergy Clin Immunol* 2011;127:218–22.
- Rubio M, Bousquet PJ, Gomes E, Romano A, Demoly P. Results of drug hypersensitivity evaluations in a large group of children and adults. *Clin Exp Allergy* 2012;42:123–30.
- Ferrandiz-Pulido C, Garcia-Patos V. A review of causes of Stevens-Johnson syndrome and toxic epidermal necrolysis in children. *Arch Dis Child* 2013;98:998–1003.
- Ponvert C, Perrin Y, Bados-Albiero A, Le Bourgeois M, Karila C, Delacourt C, et al. Allergy to betalactam antibiotics in children: results of a 20-year study based on clinical history, skin and challenge tests. *Pediatr Allergy Immunol* 2011; 22:411–18.
- Torres MJ, Ariza A, Mayorga C, Dona I, Blanca-Lopez N, Rondon C, et al. Clavulanic acid can be the component in amoxicillin-clavulanic acid responsible for immediate hypersensitivity reactions. *J Allergy Clin Immunol* 2010;125:502–5 e502.
- Atanaskovic-Markovic M, Gaeta F, Gavrovic-Jankulovic M, Cirkovic Velickovic T, Valluzzi RL, Romano A. Diagnosing multiple drug hypersensitivity in children. *Pediatr Allergy Immunol* 2012;23:785–91.
- Zambonino MA, Corzo JL, Munoz C, Requena G, Ariza A, Mayorga C, et al. Diagnostic evaluation of hypersensitivity reactions to beta-lactam antibiotics in a large population of children. *Pediatr Allergy Immunol* 2014;25:80–7.
- Corzo JL, Zambonino MA, Munoz C, Mayorga C, Requena G, Urda A, et al. Tolerance to COX-2 inhibitors in children with hypersensitivity to nonsteroidal anti-inflammatory drugs. *Br J Dermatol* 2014;170:725–9.
- Caubet JC, Rudzeviciene O, Gomes E, Terreehorst I, Brockow K, Eigenmann PA. Managing a child with possible allergy to vaccine. *Pediatr Allergy Immunol* 2014;25:394–403.

## REFERENCES

- Johansson SG, Bieber T, Dahl R, Friedmann PS, Lanier BQ, Lockey RF, et al. Revised nomenclature for allergy for global use: Report of the Nomenclature Review Committee of the World Allergy Organization, October 2003. *J Allergy Clin Immunol* 2004;113:832–6.
- Gomes E, Cardoso MF, Praca F, Gomes L, Marino E, Demoly P. Self-reported drug allergy in a general adult Portuguese population. *Clin Exp Allergy* 2004;34:1597–601.
- Mittmann N, Knowles SR, Gomez M, Fish JS, Cartotto R, Shear NH. Evaluation of the extent of under-reporting of serious adverse drug reactions: the case of toxic epidermal necrolysis. *Drug Saf* 2004;27:477–87.
- Messaad D, Sahla H, Benahmed S, Godard P, Bousquet J, Demoly P. Drug provocation tests in patients with a history suggesting an immediate drug hypersensitivity reaction. *Ann Intern Med* 2004;140:1001–6.
- Ponvert C, Weilenmann C, Wassenberg J, Walecki P, Bourgeois ML, de Blic J, et al. Allergy to betalactam antibiotics in children: a prospective follow-up study in retreated children after negative responses in skin and challenge tests. *Allergy* 2007;62:42–6.
- Demoly P, Romano A, Botelho C, Bousquet-Rouanet L, Gaeta F, Silva R, et al. Determining the negative predictive value of provocation tests with beta-lactams. *Allergy* 2010;65:327–32.
- Joint Task Force on Practice Parameters, American Academy of Allergy AaIAcOA, Asthma and Immunology; Joint Council of Allergy, Asthma and Immunology. Drug allergy: an updated practice parameter. *Ann Allergy Asthma Immunol* 2010;105:259–73.
- Kelso JM, Greenhawt MJ, Li JT, Nicklas RA, Bernstein DI, Blessing-Moore J, et al. Adverse reactions to vaccines practice parameter 2012 update. *J Allergy Clin Immunol* 2012;130:25–43.
- Mirakian R, Ewan PW, Durham SR, Youlten LJ, Dugue P, Friedmann PS, et al. BSACI guidelines for the management of drug allergy. *Clin Exp Allergy* 2009;39:43–61.
- Ewan PW, Dugue P, Mirakian R, Dixon TA, Harper JN, Nasser SM. BSACI guidelines for the investigation of suspected anaphylaxis during general anaesthesia. *Clin Exp Allergy* 2010;40:15–31.
- Przybilla B, Aberer W, Bircher AJ, Brehler R, Brockow K, Dickel H, et al. Allergological approach to drug hypersensitivity reactions. *J Dtsch Dermatol Ges* 2008;6:240–3.
- Demoly P, Kropf R, Bircher A, Pichler WJ, EAACI interest group on drug hypersensitivity. Drug hypersensitivity: questionnaire. *Allergy* 1999;54:999–1003.
- Brockow K, Romano A, Blanca M, Ring J, Pichler W, Demoly P. General considerations for skin test procedures in the diagnosis of drug hypersensitivity. *Allergy* 2002;57:45–51.
- Aberer W, Bircher A, Romano A, Blanca M, Campi P, Fernandez J, et al. Drug provocation testing in the diagnosis of drug hypersensitivity reactions: general considerations. *Allergy* 2003;58:854–63.
- Torres MJ, Blanca M, Fernandez J, Romano A, Weck A, Aberer W, et al. Diagnosis of immediate allergic reactions to beta-lactam antibiotics. *Allergy* 2003;58:961–72.
- Romano A, Blanca M, Torres MJ, Bircher A, Aberer W, Brockow K, et al. Diagnosis of nonimmediate reactions to beta-lactam antibiotics. *Allergy* 2004;59:1153–60.
- Brockow K, Christiansen C, Kanny G, Clement O, Barbaud A, Bircher A, et al. Management of hypersensitivity reactions to iodinated contrast media. *Allergy* 2005;60:150–8.
- Bousquet PJ, Demoly P, Romano A, Aberer W, Bircher A, Blanca M, et al. Pharmacovigilance of drug allergy and hypersensitivity using the ENDA-DAHD database and the GALEN platform. The Galenda project. *Allergy* 2009;64:194–203.
- Blanca M, Romano A, Torres MJ, Fernandez J, Mayorga C, Rodriguez J, et al. Update on the evaluation of hypersensitivity reactions to beta-lactams. *Allergy* 2009;64:183–93.
- Cernadas JR, Brockow K, Romano A, Aberer W, Torres MJ, Bircher A, et al. General considerations on rapid desensitization for drug hypersensitivity – a consensus statement. *Allergy* 2010;65:1357–66.
- Mertes PM, Malinovsky JM, Jouffroy L, Aberer W, Terreehorst I, Brockow K, et al. Reducing the risk of anaphylaxis during anaesthesia: 2011 updated guidelines for clinical practice. *J Investig Allergol Clin Immunol* 2011;21:442–53.
- Kowalski ML, Makowska JS, Blanca M, Bavbek S, Bochenek G, Bousquet J, et al. Hypersensitivity to nonsteroidal anti-inflammatory drugs (NSAIDs) – classification, diagnosis and management: review of the EAACI/ENDA(®) and GA2LEN/HANNA. *Allergy* 2011;66:818–29.
- Brockow K, Garvey LH, Aberer W, Atanaskovic-Markovic M, Barbaud A, Bilo MB, et al. Skin test concentrations for systemically administered drugs – an ENDA/EAACI Drug Allergy Interest Group position paper. *Allergy* 2013;68:702–12.
- Nizankowska-Mogilnicka E, Bochenek G, Mastalerz L, Swierczynska M, Picado C, Scadding G, et al. EAACI/GA2LEN guideline: aspirin provocation tests for diagnosis of aspirin hypersensitivity. *Allergy* 2007;62:1111–18.
- Scherer Hofmeier K, in press. 2013.
- Thong B, Motala C, Vervloet D. Disease summaries – Drug allergies. Available from: [http://www.worldallergy.org/professional/allergic\\_diseases\\_center/drugallergy/](http://www.worldallergy.org/professional/allergic_diseases_center/drugallergy/).
- Pichler WJ, Thong B. GLORIA module 11. Drug allergy. Available from: [http://www.worldallergy.org/educational\\_programs/loria/international/materials.php](http://www.worldallergy.org/educational_programs/loria/international/materials.php).
- Lotvall J, Pawankar R, Wallace DV, Akdis CA, Rosenwasser LJ, Weber RW, et al. We call for iCAALL: International Collaboration in Asthma, Allergy and Immunology. *Allergy* 2012;67:449–50.
- Demoly P, Adkinson NF, Brockow K, Castells M, Chiriac AM, Greenberger PA, et al. International Consensus on drug allergy. *Allergy* 2014;69:420–37.
- Papadopoulos NG, Arakawa H, Carlsen KH, Custovic A, Gern J, Lemanske R, et al. International consensus on (ICON) pediatric asthma. *Allergy* 2012;67:976–97.
- Thong BY, Tan TC. Epidemiology and risk factors for drug allergy. *Br J Clin Pharmacol* 2011;71:684–700.
- Impicciatore P, Choonara I, Clarkson A, Provasi D, Pandolfini C, Bonati M. Incidence of adverse drug reactions in paediatric in/outpatients: a systematic review and meta-analysis of prospective studies. *Br J Clin Pharmacol* 2001;52:77–83.
- Macy E, Poon KYT. Self-reported antibiotic allergy incidence and prevalence: age and sex effects. *Am J Med* 2009;122:778 e771–7.
- Rebello Gomes E, Fonseca J, Araujo L, Demoly P. Drug allergy claims in children: from self-reporting to confirmed diagnosis. *Clin Exp Allergy* 2008;38:191–8.
- Ponvert C, Le Clainche L, de Blic J, Le Bourgeois M, Scheinmann P, Paupe J. Allergy to beta-lactam antibiotics in children. *Pediatrics* 1999;104:e45.
- Caubet JC, Kaiser L, Lemaitre B, Fellay B, Gervais A, Eigenmann PA. The role of penicillin in benign skin rashes in childhood: a prospective study based on drug rechallenge. *J Allergy Clin Immunol* 2011;127:218–22.
- Caubet JC, Eigenmann PA. Managing possible antibiotic allergy in children. *Curr Opin Infect Dis* 2012;25:279–85.
- Blanca M, Torres MJ, Garcia JJ, Romano A, Mayorga C, de Ramon E, et al. Natural evolution of skin test sensitivity in patients allergic to beta-lactam antibiotics. *J Allergy Clin Immunol* 1999;103(5 Pt 1):918–24.
- Barbaud A, Collet E, Milpied B, Assier H, Stauromont D, Avenel-Audran M, et al. A multicentre study to determine the value and safety of drug patch tests for the three main classes of severe cutaneous adverse drug reactions. *Br J Dermatol* 2013;168:555–62.
- Rubio M, Bousquet PJ, Gomes E, Romano A, Demoly P. Results of drug hypersensitivity evaluations in a large group of children and adults. *Clin Exp Allergy* 2012;42:123–30.
- Ferrandiz-Pulido C, Garcia-Patos V. A review of causes of Stevens-Johnson syndrome and toxic epidermal necrolysis in children. *Arch Dis Child* 2013;98:998–1003.
- Raucci U, Rossi R, Da Cas R, Rafaniello C, Mores N, Bersani G, et al. Stevens-Johnson syndrome associated with drugs and vaccines in children: a case-control study. *PLoS ONE* 2013;8:e68231.
- Gomes ER, Kvedariene V, Demoly P, Bousquet PJ. Patients' satisfaction with diagnostic drug provocation tests and perception of its usefulness. *Int Arch Allergy Immunol* 2011;156:333–8.
- Ponvert C. Diagnosis of allergic and non-allergic hypersensitivity reactions to commonly used drugs and biological substances in children: diagnostic algorithm. *Arch Pediatr* 2011;18:486–92.
- Benahmed S, Scaramuzza C, Messaad D, Sahla H, Demoly P. The accuracy of the diagnosis of suspected macrolide antibiotic hypersensitivity: results of a single-blinded trial. *Allergy* 2004;59:1130–3.
- Ponvert C, Perrin Y, Bados-Albiero A, Le Bourgeois M, Karila C, Delacourt C, et al. Allergy to betalactam antibiotics in children: results of a 20-year study based on clinical history, skin and challenge tests. *Pediatr Allergy Immunol* 2011;22:411–18.
- Chambel M, Martins P, Silva I, Palma-Carlos S, Romeira AM, Leiria Pinto P. Drug provocation tests to betalactam antibiotics: experience in a paediatric setting. *Allergol Immunopathol (Madr)* 2010;38:300–6.
- Finkelstein Y, Soon GS, Acuna P, George M, Pope E, Ito S, et al. Recurrence and outcomes of Stevens-Johnson syndrome and toxic epidermal necrolysis in children. *Pediatrics* 2011;128:723–8.



49. Torres MJ, Ariza A, Mayorga C, Dona I, Blanca-Lopez N, Rondon C, et al. Clavulanic acid can be the component in amoxicillin-clavulanic acid responsible for immediate hypersensitivity reactions. *J Allergy Clin Immunol* 2010;125:502–5 e502.
50. Sanchez-Morillas L, Perez-Ezquerria PR, Reano-Martos M, Laguna-Martinez JJ, Sanz ML, Martinez LM. Selective allergic reactions to clavulanic acid: a report of 9 cases. *J Allergy Clin Immunol* 2010;126:177–9.
51. Atanaskovic-Markovic M, Gaeta F, Gavrovic-Jankulovic M, Cirkovic Velickovic T, Valluzzi RL, Romano A. Diagnosing multiple drug hypersensitivity in children. *Pediatr Allergy Immunol* 2012;23:785–91.
52. Co Minh HB, Bousquet PJ, Fontaine C, Kvedariene V, Demoly P. Systemic reactions during skin tests with beta-lactams: a risk factor analysis. *J Allergy Clin Immunol* 2006;117:466–8.
53. Gadde J, Spence M, Wheeler B, Adkinson NF Jr. Clinical experience with penicillin skin testing in a large inner-city STD clinic. *JAMA* 1993;270:2456–63.
54. Pichichero ME, Pichichero DM. Diagnosis of penicillin, amoxicillin, and cephalosporin allergy: reliability of examination assessed by skin testing and oral challenge. *J Pediatr* 1998;132:137–43.
55. Zambonino MA, Corzo JL, Munoz C, Requena G, Ariza A, Mayorga C, et al. Diagnostic evaluation of hypersensitivity reactions to beta-lactam antibiotics in a large population of children. *Pediatr Allergy Immunol* 2014;25:80–7.
56. Matar R, Le Bourgeois M, Scheinmann P, de Blic J, Ponvert C. Beta-lactam hypersensitivity in children with cystic fibrosis: a study in a specialized pediatric center for cystic fibrosis and drug allergy. *Pediatr Allergy Immunol* 2014;25:88–93.
57. Caimmi S, Sanfiorenzo C, Caimmi D, Bousquet PJ, Chiron R, Demoly P. Comprehensive allergy work-up is mandatory in cystic fibrosis patients who report a history suggestive of drug allergy to beta-lactam antibiotics. *Clin Transl Allergy* 2012;2:10.
58. Whitaker P, Shaw N, Gooi J, Etherington C, Conway S, Peckham D. Rapid desensitization for non-immediate reactions in patients with cystic fibrosis. *J Cyst Fibros* 2011;10:282–5.
59. Whitaker P, Naisbitt D, Peckham D. Nonimmediate beta-lactam reactions in patients with cystic fibrosis. *Curr Opin Allergy Clin Immunol* 2012;12:369–75.
60. Fernandez TD, Mayorga C, Ariza A, Corzo JL, Torres MJ. Allergic reactions to antibiotics in children. *Curr Opin Allergy Clin Immunol* 2014;14:278–85.
61. Schnyder B, Pichler WJ. Allergy to sulfonamides. *J Allergy Clin Immunol* 2013;131:256–7. e251–5.
62. Demoly P, Messaad D, Reynes J, Faucherre V, Bousquet J. Trimethoprim-sulfamethoxazole-graded challenge in HIV-infected patients: long-term follow-up regarding efficacy and safety. *J Allergy Clin Immunol* 2000;105:588–9.
63. Kuyucu S, Mori F, Atanaskovic-Markovic M, Caubet JC, Terreehorst I, Gomes E, et al; Pediatric Task Force of EAACI Drug Allergy Interest Group. Hypersensitivity reactions to non-beta-lactam antibiotics in children: an extensive review. *Pediatr Allergy Immunol* 2014;25:534–43.
64. Kowalski ML, Asero R, Bavbek S, Blanca M, Blanca-Lopez N, Bochenek G, et al. Classification and practical approach to the diagnosis and management of hypersensitivity to nonsteroidal anti-inflammatory drugs. *Allergy* 2013;68:1219–32.
65. Yilmaz O, Ertoy Karagol IH, Bakirtas A, Topal E, Celik GE, Demirsoy MS, et al. Challenge-proven nonsteroidal anti-inflammatory drug hypersensitivity in children. *Allergy* 2013;68:1555–61.
66. Corzo JL, Zambonino MA, Munoz C, Mayorga C, Requena G, Urda A, et al. Tolerance to COX-2 inhibitors in children with hypersensitivity to nonsteroidal anti-inflammatory drugs. *Br J Dermatol* 2014;170:725–9.
67. Dona I, Blanca-Lopez N, Jagemann LR, Torres MJ, Rondon C, Campo P, et al. Response to a selective COX-2 inhibitor in patients with urticaria/angioedema induced by nonsteroidal anti-inflammatory drugs. *Allergy* 2011;66:1428–33.
68. Boussetta K, Ponvert C, Karila C, Bourgeois ML, Blic J, Scheinmann P. Hypersensitivity reactions to paracetamol in children: a study of 25 cases. *Allergy* 2005;60:1174–7.
69. Kidon MI, Kang LW, Chin CW, Hoon LS, See Y, Goh A, et al. Early presentation with angioedema and urticaria in cross-reactive hypersensitivity to nonsteroidal antiinflammatory drugs among young, Asian, atopic children. *Pediatrics* 2005;116:e675–80.
70. Ameratunga R, Randall N, Dalziel S, Anderson BJ. Samter's triad in childhood: a warning for those prescribing NSAIDs. *Paediatr Anaesth* 2013;23:757–9.
71. Caubet JC, Rudzeviciene O, Gomes E, Terreehorst I, Brockow K, Eigenmann PA. Managing a child with possible allergy to vaccine. *Pediatr Allergy Immunol* 2014;25:394–403.
72. Bohlke K, Davis RL, Marcy SM, Braun MM, DeStefano F, Black SB, et al. Risk of anaphylaxis after vaccination of children and adolescents. *Pediatrics* 2003;112:815–20.
73. Zent O, Arras-Reiter C, Broecker M, Hennig R. Immediate allergic reactions after vaccinations – a post-marketing surveillance review. *Eur J Pediatr* 2002;161:21–5.
74. Chiriac AM, Demoly P. Multiple drug hypersensitivity syndrome. *Curr Opin Allergy Clin Immunol* 2013;13:323–9.
75. Studer M, Waton J, Bursztejn AC, Aimone-Gastin I, Schmutz JL, Barbaud A. Does hypersensitivity to multiple drugs really exist? *Ann Dermatol Venereol* 2012;139:375–80.
76. Neukomm CB, Yawalkar N, Helbling A, Pichler WJ. T-cell reactions to drugs in distinct clinical manifestations of drug allergy. *J Invest Allergol Clin Immunol* 2001;11:275–84.
77. Barbaud A, Waton J, Herbeth B, Bursztejn AC, Bollaert M, Schmutz JL, et al. Comparison of cytokine gene polymorphism in drug-induced maculopapular eruption, urticaria and drug reaction with eosinophilia and systemic symptoms (DRESS). *J Eur Acad Dermatol Venereol* 2014;28:491–9.

# Latex Allergy

KEVIN J. KELLY | BRIAN T. KELLY

## KEY POINTS

- Natural rubber latex (NRL) is contained in thousands of consumer and medical products and is responsible for an epidemic of IgE-mediated latex allergy in the past three decades. Products made by a dipping method (e.g. gloves, condoms) have the highest content of allergenic protein that may result in urticaria, angioedema, asthma, rhinoconjunctivitis and anaphylaxis. Latex finished products contain multiple chemicals that may induce cell-mediated contact dermatitis, although this is uncommon in pediatric practice.
- Latex proteins may have clinical cross-reactivity with multiple foods and lead to clinical allergic responses, especially to banana, avocado and/or kiwi, in nearly 50% of latex-allergic subjects. A small subset of patients with fruit and vegetable allergies may develop allergic reactions from cross-reactions to latex but these occur in less than 15% of patients.
- Patients with spina bifida are at highest risk of developing latex allergy. Occupational asthma is a common problem seen in adult workers exposed to latex materials that use a cornstarch donning powder, which may carry latex protein into the ambient environment.
- Diagnosis is best achieved by performance of a history, physical examination and allergy tests using skin test, serologic tests and provocation tests, although standard reagents are lacking. Serologic tests may produce false-positive results by a variety of mechanisms while up to 25% of serologic tests may be falsely negative.
- Avoidance of latex through 'latex safe precautions' is essential for the treatment of latex allergy.

## Introduction

In the 1980s a worldwide epidemic of immunoglobulin E (IgE)-mediated allergy to natural rubber latex (referred to as NRL or latex) occurred. A marked increase in personal exposure to latex with the implementation of healthcare standard precautions and manufacturing changes in latex production resulted in sensitization to protein allergens retained in finished products. This chapter reviews the clinical presentation of latex allergy (LA), production of latex products, patterns of latex use in the context of clinical symptoms, allergens, diagnosis, clinical and laboratory cross-reactivity with foods and pollens, and treatment options.

## Clinical Manifestations – Initial Observations

The clinical circumstances in patients who develop LA are highly variable and may not be readily recognized by patients.

This requires clinicians to have a high index of suspicion and astute diagnostic skills.

In 1927, a single case of chronic urticaria from contact with rubber prosthetics was reported in the German literature.<sup>1</sup> It was not until 1979 that the first clear case of LA was reported in a homemaker.<sup>2</sup> The diagnosis was confirmed by a medical history of intense pruritus and atopic dermatitis after the use of rubber gloves, with confirmation by patch test and prick test-induced hives from a latex glove. The clinical spectrum of LA was broadened by the first report of latex exposure in a healthcare worker causing urticaria, rhinitis and ocular symptoms.<sup>3</sup>

The introduction of standard precautions saw an exponential rise in latex exam glove use, paralleling a rise in reporting of LA but latex is now being replaced by nitrile butadiene rubber (Figure 56-1) in exam gloves. A 1987 prevalence study confirmed the presence of LA in 15/512 (2.9%) hospital employees screened by prick test to latex.<sup>4</sup> A subset of individuals (operating room personnel) had the highest prevalence at 6.2%. Atopy was found to be a strong contributing factor to LA development with 10/15 (66.7%) of subjects having environmental allergies. In 1987, Axelsson et al reported five individuals with systemic reactions to latex gloves; only one was a healthcare worker.<sup>5</sup> Seaton and Cherrie completed the medical literature spectrum of latex allergy manifestations a decade after the first modern publication, when a case of occupational asthma caused by latex gloves was confirmed, and suggested that latex exposure came from airborne allergen.<sup>6</sup> Previous mucosal reactions of conjunctivitis and rhinitis were believed to have come from direct allergen transfer by hand contact. This report moved the medical community toward an understanding that the environment could be contaminated by allergen-carrying glove powder.

After these earliest observations, specific risk groups emerged with common exposures. Throughout the first decade of reporting this disorder, women, healthcare workers and atopic individuals were identified as being at risk. Reports identified individuals undergoing surgical operations having severe allergic reactions during anesthesia. Two children with spina bifida suffered anaphylactic reactions when undergoing anesthesia in two completely different clinical scenarios. One child experienced systemic symptoms within 15 minutes of anesthesia induction and prior to surgical incision while the other child's reaction occurred at the time of closure of the surgical incision. These reactions were characterized by generalized flushing, expiratory wheezing, marked increase in airway pressure needed to mechanically ventilate, and severe hypotension requiring epinephrine for symptom reversal. These observations were confirmed in the next 3 years by multiple clinical observations of allergic reactions in spina bifida patients undergoing surgery.<sup>7-9</sup>

## SPINA BIFIDA

Children with spina bifida (SB) emerged in the early 1990s as the group at highest risk for developing LA.<sup>10</sup> Recurrent

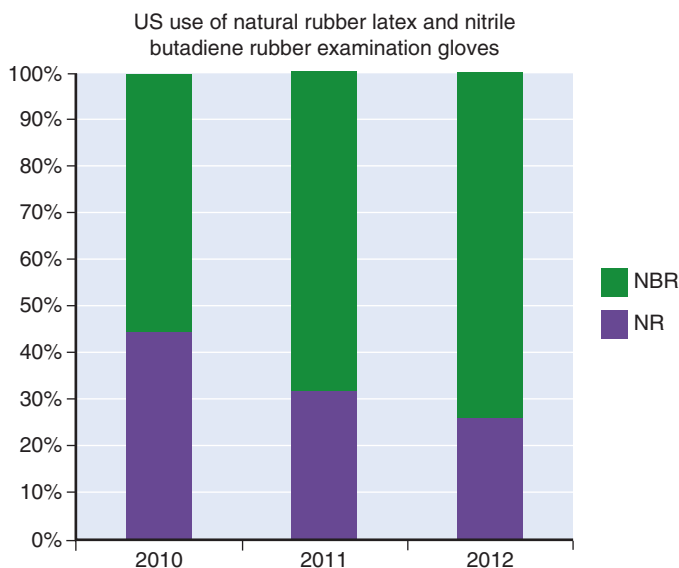

**Figure 56-1** The introduction of standard precautions saw an exponential rise in use of latex examination gloves but not sterile surgical latex gloves. After 2009, a marked buying change of latex examination gloves occurred in the USA with nitrile butadiene rubber (NBR) replacing natural rubber (NR) as the most common source for latex gloves. In addition, powdered latex examination gloves now constitute a small proportion of latex examination gloves. (Adapted from Whitfield A. Synthomer Investor Day pdf presentation on November 19, 2013 at [http://www.synthomer.com/fileadmin/content\\_investor/2013/Investorday2013.pdf](http://www.synthomer.com/fileadmin/content_investor/2013/Investorday2013.pdf).)

exposure to latex products in their daily care, multiple surgeries, atopic disposition and epigenetic factors may all contribute to this response. Patients with SB seem exceptionally capable of mounting an IgE response to latex proteins, with subjects undergoing surgery in a prior year having a 68% prevalence of NRL sensitization. Alarming, one of every eight patients with SB in one hospital, prior to the use of latex avoidance precautions in the operating room, developed systemic allergic reactions during anesthesia, representing a 500-fold higher rate of anaphylaxis than expected during general anesthesia and surgery. Two case series reported anaphylaxis occurring 40 to 220 minutes into surgery with direct mucosal glove contact, while another series noted anaphylaxis within 30 minutes of the induction of anesthesia.<sup>9,10</sup> One case series compared differences between SB patients who developed intraoperative anaphylaxis and those who did not, while a second case series compared SB to atopic and nonatopic control groups. SB groups developed LA more frequently than atopic subjects (40.5% vs 11.4%) and at >20 times the rate of healthy controls (40.5% vs 1.9%). Other case series without control groups suggest that atopy, > 5 surgeries, high antilatax IgE (>3.5 kU/L), and skin test reactivity to foods (kiwi, pear or tomato) are important factors.<sup>11–15</sup>

Recently, sensitization to latex in SB patients has declined significantly (5% vs 55%) with the introduction of latex safe conditions.<sup>16</sup> Therefore, latex avoidance measures have been extremely successful in reducing sensitization and allergy in patients with SB.

### LATEX ALLERGY IN PATIENTS WITH UROLOGIC OR NEUROLOGIC DEFECTS

In addition to patients with SB, patients with cloacal anomalies, chronic renal failure or bladder anomalies are at risk for latex

anaphylaxis. Two studies published in the same year reached opposite conclusions about the risk of LA or sensitization in patients with spinal cord injuries. Konz et al performed a cross-sectional study of 36 SB patients, 50 patients with spinal cord injury, 10 patients with cerebrovascular accidents and 10 healthy control patients.<sup>17</sup> While 72% of the SB subjects had clinical histories and confirming tests compatible with LA, no positive histories were identified in either of the other two groups with neural disease. Antilatex IgE was noted in 4% of spinal cord-injured patients despite no history of latex-induced reactions. Vogel et al reported only 2/67 spinal cord-injured patients with a clinical history of latex reactions, but 10 (15%) with evidence of latex sensitization, a historically higher rate than the general population.<sup>18</sup> Regardless, there appear to be significant differences between neurologically injured patients and patients with SB.

### HEALTHCARE WORKERS

The clinical manifestations of healthcare workers' (HCW) disease are quite different from other groups.<sup>19–23</sup> While most children with LA do not have irritant dermatitis or contact dermatitis, the majority of latex-allergic healthcare workers show evidence of dermatitis, with the irritant type being the most prevalent. Hand symptoms have been correlated closely with latex sensitization. In fact, HCW with more than two hand symptoms are 11 times more likely to have positive skin prick tests.<sup>24</sup> Dermatitis often heralds the development of IgE-mediated symptoms of urticaria, angioedema, occupational asthma, rhinoconjunctivitis and anaphylaxis, but is not a prerequisite for the development of LA. The prevalence of HCW disease has ranged from 5% to 17% with >50% having latex-induced asthma. Several reasons for LA development in this group include frequent use of latex gloves, manufacturing changes that lead to higher allergen content of gloves, processing changes or manufacturing changes. Airborne antigen exposure has been found to be a significant source of latex sensitization among HCWs. The use of powder-free examination gloves reduces the risk of sensitization 16-fold.<sup>25</sup>

### SURGERY

Multiple reports suggest that surgical intervention increases LA risk.<sup>12,26</sup> In addition, children with cerebral palsy, esophageal atresia, gastroschisis and omphalocele may be at higher risk. Since these diseases are confounded by frequent latex glove use and multiple surgeries, the contribution of each variable is unclear.

### LATEX ALLERGY IN THE GENERAL POPULATION

Multiple reports and clinical experience have shown that individuals with no apparent risk factors of exposure, SB, healthcare work or surgery may develop LA. The symptoms in these individuals are usually predicted by the route of exposure: rhinitis, conjunctivitis and asthma occur after inhalation, while anaphylaxis occurs after abdominal mucosa or intravenous exposure. The most dramatic presentations were the first cases of anaphylaxis seen after rectal mucosal surface exposure to latex balloons, glove or condom materials. In the 1980s, air contrast barium enema procedures used a catheter that was inflated to help retain the air and barium in the colon.<sup>27,28</sup> Rectal

manometry with a catheter tipped with a balloon or covered by condom material was common. Case series described severe anaphylaxis, including deaths, associated with these procedures. Only in retrospect were these cases identified as LA, with most occurring in non-healthcare workers, although some were atopic or had had prior surgery. One particular catheter was implicated in barium enema-induced anaphylaxis (E-Z-Em Company) with as many as 148 episodes of anaphylaxis and 9 deaths. Most of these subjects were not from identified risk groups, raising significant concern about the risk in the general population.

Two large studies<sup>26,29</sup> showed a prevalence of LA in children of 0.7% to 1.1%, well below the reported prevalence in children with SB and healthcare workers. These observations were contrasted by serologic studies from blood donors, non-healthcare workers, and consecutive emergency department patients that demonstrated antilatax IgE presence in the blood of 4% to 8% of these subjects.<sup>29-34</sup> Whether this represents a predictable rate of false-positive tests in low-prevalence populations, or accurate results in subjects at risk of latex-allergic reactions following future exposures, is unclear.

## FRUIT ALLERGY AND CONCURRENT LATEX ALLERGY

Clinical observations raised the question of pan-allergens and clinical cross-reactivity of fruit and latex. Multiple clinical reactions to bananas, kiwi, avocado, mango, chestnut, papaya and stone fruits such as cherries or peaches have been published in known latex-allergic subjects.<sup>34-41</sup> In addition, individuals with primary food allergy have had clinical reactions to latex, but much less frequently than might have been expected from the initial frequency of in vitro allergen cross-reactions. This syndrome has been termed the 'latex-fruit syndrome' and was extended to the 'latex-vegetable syndrome' when cross-reactions were found between a number of vegetables and latex proteins.

Over 50% of individuals with LA may have clinical reactions to fruit (Table 56-1) due to specific cross-reacting allergens.<sup>31</sup> A common tertiary structure of Hev b 6 (hevein) is shared with

two banana proteins, avocado and chestnut. Kiwi has significant homology with Hev b 5.<sup>42-44</sup> While Hev b 7 has structural similarity to patatin from potato, the clinical relevance may be minor. Hev b 8, a profilin, may cross-react with other plant profilins. Hev b 2 is a pathogen-related protein  $\beta$ -1,3-glucan with cross-reactive homology. Hev b 12 is a lipid transfer protein that has been a common protein type to cause clinical reactions to vegetables and fruit in patients who are pollen reactive.

Latex-fruit syndrome was investigated from the perspective of whether individuals with primary fruit allergy have concurrent LA. Of 57 subjects with primary fruit allergy, 49 (86%) had IgE reactivity in serum and/or skin test. Only 6 (12.2%) reported prior symptoms from latex exposure; however, fruit allergy symptoms preceded these.<sup>45</sup>

The concern of hidden food allergen has been brought to light by multiple reports of transfer of allergen to food (a bagel, cheese, lettuce and doughnut) by handlers wearing latex gloves.<sup>46,47</sup>

## DIABETES AND LATEX ALLERGY

The development of LA in patients with type 1 diabetes was unexpected.<sup>48</sup> In 1995, anaphylaxis was reported during surgery and was presumed to be from latex contamination of injectable medication drawn from a latex rubber-topped bottle during anesthesia. A series of case reports<sup>49-51</sup> and a prevalence study investigating the risk of LA in individuals who require insulin injection were subsequently reported. Local allergic reactions at the site of insulin injection occurred after the needle used to draw up the insulin was inserted through a rubber-stopped bottle containing latex. Removal of the latex top and subsequent drawing up of the insulin into the syringe did not produce allergic reactions in any of these cases. These observations suggest that the latex stopper does not contaminate the medication vial, but does contaminate the needle during insertion. One report in the pharmacy literature found that multiple needle punctures of multidose vials did not elute allergen in sufficient quantity to result in allergic reactions. Serum samples from children with type 1 diabetes demonstrated that latex-specific IgE was detectable only in atopic diabetic children, but was not more prevalent than in nondiabetic atopic subjects. In this study, 7/112 (6%) of subjects had IgE antibody and were all derived from the atopic group of 42 subjects (17%). In contrast, none (0/70) of the nonatopic subjects had antilatax IgE antibody detected in the serum.<sup>52</sup>

## Latex Production

Produced by nearly 2,000 lactiferous plants and trees, the polymer cis-1,4 polyisoprene has been exploited for broad commercial use from the tree *Hevea brasiliensis* and recently from other lactiferous plants such as guayule latex.<sup>53-57</sup> Charles Goodyear's critical discovery of sulfur heat vulcanization, a method that effectively cross-links the rubber polyisoprene while reducing the tackiness and sensitivity to temperature change of latex, catapulted NRL use into one of the most important industries in the world. Worldwide latex consumption has increased dramatically, with nearly 6 million tons/year produced in 1995 and over 21 million tons/year utilized, mainly due to China's spectacular economic growth. Latex demand for NRL in Japan, Europe and North America has remained stable. Whether a new epidemic of LA will emerge in China is unknown.

**TABLE 56-1** Foods that Cross-React with *Hevea brasiliensis* Latex

Primary Food Allergies Causing Latex Reactions	Clinical Cross-Reacting Foods
Bananas Melons Peaches	Avocados Bananas Chestnuts Kiwi Papaya Potato
FOODS WITH IN VITRO CROSS-REACTIVITY BUT UNCOMMON IN VIVO SYMPTOMS IN LATEX ALLERGY	
Apple Bell pepper Celery Cherry Fig Mango	Passion fruit Pear Pineapple Tomato Turnip Wheat



Rubber hydrocarbon (cis-1,4 polyisoprene) makes up the majority of the latex suspension while protein, carbohydrate, lipids, inorganic constituents and amino acids are a minor percentage of the mix. Despite proteins being a minor portion of NRL, the retention of these proteins in finished products is the cause of IgE-mediated reactions in humans. During the manufacturing of latex products, over 200 different chemicals have been utilized and fall into broad categories of accelerators of cross-linking, antioxidants, antiozonates, biocides, colorants, epoxies and plasticizers. It is the accelerator class of chemicals, including thiurams, thiazoles and carbamates, that most frequently causes type IV cell-mediated contact dermatitis of the skin from latex. Synthetic rubber materials and alternative medical glove materials may retain these same chemicals, resulting in contact dermatitis. Gloves made of polyvinyl chloride, styrene butadiene rubber or Tactylon® (styrene ethylene butylene styrene) may not contain these accelerators.

### LATEX COLLECTION

NRL flows through a circulation system of the tree and is collected when bark is shaved off just short of the cambium layer. Latex is treated with a stabilizer such as sodium sulfite, formaldehyde, ammonia (0.05–0.2%) or ammonia with a 1 : 1 mixture of zinc oxide and tetramethylthiuram disulfide (TMTD). A number of chemicals can be used to enhance the yield of latex. Such chemicals (e.g. 2-chloroethylphosphonic acid or ethepon) may enhance the quantity and type of allergenic proteins. Demand to produce more medical-grade latex with the advent of standard precautions in the 1980s resulted in more frequent tapping of trees and reduced storage time of latex. As many allergenic proteins are defense proteins, their production may have been enhanced.

### LATEX PRODUCT MANUFACTURING

Approximately 88% or more of the world's harvested latex is acid coagulated, prepared as dry raw rubber in sheets or crumbs of technically specified rubber and dried at 60°C or higher temperature. Allergic IgE reactions have been rarely reported from this type of rubber but contact reactions may be seen.

The other 10% to 12% of NRL is produced in a latex concentrate by centrifugation or creaming to make products such as gloves and condoms from a dipping method. Most latex is concentrated to 60% isoprene, stabilized in either a high concentration of ammonia (0.7%) or low ammonia (0.2%) with TMTD and zinc oxide and stored in tanks for at least 2 to 3 weeks and often longer before being shipped to manufacturers. After shipping, the latex is prepared by the manufacturer, with proprietary methods, for dipping of forms (e.g. gloves) coated with a surface coagulant into latex slurry. The latex adheres to the form, is wet leached, heat vulcanized and dried, and various methods are used to prevent the latex products from sticking to each other. In the past, the most common agent used to prevent sticking was highly cross-linked cornstarch powder or talc. Given its ability to act as a carrier of latex allergen, cornstarch powder has fallen out of favor. Talc was found to induce granulomatous inflammation and decrease wound healing and has mostly been abandoned in medical-grade gloves. Halogenation or surface coating with a synthetic polymer has been useful in replacing donning powder.

## Latex Allergens

Field latex varies in its protein content by clonal origin of the rubber plant, climatic factors, soil types, fertilizers and yield enhancers used for the rubber cultivation. Latex-producing trees are susceptible to invasion by a variety of microorganisms, especially fungi, and insects that can injure and kill the tree. NRL contains numerous defense-related proteins and enzymes that are integral in the protection of the plant, biosynthesis of polyisoprene and coagulation of latex, but which cause allergic sensitization and clinical reactions in susceptible hosts. Proteins present in freshly harvested latex are detected in finished latex products, either in their natural configuration or an altered configuration, which may lead to the formation of neo-antigens.<sup>53</sup> Based on their IgE-binding properties, the Allergen Nomenclature Subcommittee of the International Union of Immunological Societies (IUIS) has accepted 13 proteins as latex allergens (<http://www.allergen.org>).

### IMMUNOLOGIC PROPERTIES

The immunologic properties of individual latex allergens have been evaluated by immune responses in either healthcare workers or patients with SB since those individuals make up the majority of subjects found to have clinical disease. The allergens that the general population reacts to are likely to parallel these current observations (Table 56-2).

## Functional Properties of Latex Allergens

Latex proteins are involved in rubber biosynthesis (Hev b 1, 3, 6, 7), plant defense (Hev b 2, 4, 6.01–6.03, 7, 11, 12, 13), enzyme actions and structural formation (Hev b 5, 8, 9). Some of these proteins have multiple functions and elicit variable IgE responses in humans who contact them.<sup>44,54</sup>

### IMMUNE RESPONSES TO RUBBER BIOSYNTHESIS PROTEINS

The four allergens most involved in rubber biosynthesis include Hev b 1, Hev b 3, Hev b 6.01–6.03 and Hev b 7. What is most interesting is the dichotomy of reactions seen between healthcare workers and SB patients to this particular group of allergens. SB patients react more frequently to Hev b 1 and Hev b 3 than other risk groups, possibly due to genetic differences, surgical exposure, timing or route of exposure to the allergens.

#### *Hev b 1 (Rubber Elongation Factor or REF)*

A tetramer with a molecular mass of 58 kDa and tightly bound on large rubber particles (>350 nm in diameter), Hev b 1 is a major allergen, inducing IgE reactions in 13% to 32% of latex-sensitive healthcare workers and 52% to 100% of SB patients. This very important allergen must be present in sufficient quantity for diagnosis in patients with SB.<sup>58–60</sup>

#### *Hev b 3 (REF Homolog)*

This protein, with strong IgE-binding reactivity in patients with SB and LA, is associated with the small rubber particles (<75 nm) in latex. Clinical and immunologic reactivity of Hev b 3 with serum IgE in healthcare workers is less frequent and weaker than

**TABLE 56-2**  
**Hevea brasiliensis Latex Allergens**

Allergens	Allergen Name	Molecular Weight kDa	Function	Significance as Allergens
Hev b 1	Elongation factor	14.6	Rubber biosynthesis	Major
	<b>Tetramer</b>	58		
Hev b 2	1,3-glucanase	34/36	Defense protein	Major
Hev b 3	Elongation factor	23	Rubber biosynthesis	Major
Hev b 4	Microhelix complex	50–57	Defense protein	Major
	<b>Dimer</b>	100–115		
Hev b 5		16	Enzyme	Major
Hev b 6.01	Prohevein	20	Defense protein	Major
Hev b 6.02	Hevein	4.7	Defense protein	Major
Hev b 6.03	C-terminal hevein	14	Defense protein	Major
Hev b 7	Patatin homolog	42.9	Defense protein Inhibit rubber biosynthesis	Minor
Hev b 8	Latex profiling	14	Structural protein	Minor
Hev b 9	Latex enolase	51	Enzyme	Minor
Hev b 10	Mn superoxide dismutase	26	Enzyme	Minor
Hev b 11	Class 1 chitinase	33	Defense protein	Minor
Hev b 12	Lipid transfer protein	9.3	Defense protein	Major
Hev b 13	Latex esterase	42	Enzyme	Major

in SB patients. The amino acid sequence homology is 47% when compared to Hev b 1. Preincubated latex-allergic sera with Hev b 1 show >80% enzyme linked immunosorbent assay (ELISA) inhibition to solid phase Hev b 3, indicating the presence of similar conformational allergens in these proteins.<sup>59–61</sup>

#### Hev b 7 (Patatin-Like Protein)

An important potato storage protein allergen (Sol t 1), Hev b 7, a 46 kDa protein with patatin storage protein homology, inhibits rubber biosynthesis but also has defense hydrolase and esterase activity that inhibits the growth of invertebrate pests. IgE-binding reactivity occurs in 23% of healthcare workers with LA but Hev b 7 has not been demonstrated to be a major allergen for patients with SB.<sup>62</sup>

#### Hev b 6.01–6.03

Hev b 6.01–6.03 has latex coagulation activity but will be presented under defense-related proteins.

### IMMUNE RESPONSES TO PLANT DEFENSE-RELATED PROTEINS

The Hevea latex allergens that have defense-related functions include Hev b 2, 4, 6.01–6.03, 7 (see above), 11, 12 and 13. Most latex-allergic patients recognize one or more of these allergens and their potential cross-reactions with fruit proteins account for the serious allergic reactions after ingestion of a food with such proteins. In addition, hevamine, a common protein that is not officially accepted as an allergen, is also a defense-related protein that some individuals develop IgE antibody against.<sup>37,38,41–43,62–64</sup>

Higher plants have a defense system of proteins that is compared frequently to the immune system of animals, but in reality is significantly different. Static defense proteins (e.g. storage proteins) may exert antifungal activity (e.g. lectins) or antimicrobial activity. Pathogenesis-related proteins (PR

proteins) are encoded by the host plant but are induced only in pathologic situations (e.g. tapping of a latex tree). There are 14 identified families of PR proteins with defense functions and many are associated with food allergy cross-reactions in pollen-induced food allergy and the latex-fruit syndrome. Thus it is important to understand the type of defense proteins that are allergens in NRL in order to predict which fruit and environmental allergens will cause clinical cross-reactivity.

#### Hev b 2

This basic  $\beta$ -1,3-glucanase exhibits significant IgE binding in latex-sensitized SB and healthcare workers.<sup>63</sup> IgE reactivity may range from 20% to 61% of patients with clinical symptoms from latex allergen content. Foods such as banana, potato and tomato may contain  $\beta$ -1,3-glucanase activity, but it is not clear if this is truly the protein resulting in cross-reactions.<sup>65,66</sup>

#### Hev b 4

This microhelix component of latex is an acidic protein (50–57 kDa) and 65% of healthcare workers are found to have IgE against this component. However, only 14% of these patients showed peripheral blood mononuclear cell (PBMC) stimulation to Hev b 4.

#### Hev b 6 (Prohevein)

Hev b 6.01, one of the most abundant latex proteins, has two distinct domains: a 4.7 kDa C-terminal domain (Hev b 6.02) and an N-terminal 14 kDa peptide (Hev b 6.03).<sup>41–44</sup> Prohevein has strong reactivity with IgE from healthcare workers and SB patients with LA. The 43 amino acid-long N-domain exhibits IgE binding with a significantly higher number of latex-sensitized patients when compared to the 144 amino acid-long C-domain of Hev b 6. Skin test reactions correlate well with the in vitro IgE to latex allergens. Epitope mapping of the prohevein molecule revealed more IgE-binding regions near the N-terminal end of the protein.

### *Hev b 11 (Endochitinase)*

The class 1 chitinase shares homology with N-terminal hevein domain (resulting in cross-reactivity and the latex-fruit syndrome) and also shares epitopes with chitinases from avocado, chestnut and banana. They appear to be minor contributors to disease.<sup>38,40,41</sup>

### *Hev b 12 (Lipid Transfer Protein)*

Lipid transfer proteins with antifungal and antibacterial activity are named for their ability to transfer phospholipids from liposomes to mitochondria, and are widely distributed in the plant kingdom.<sup>64,67</sup> This class of proteins is the most important allergen in the Prunoideae fruits such as peach, cherry, apricot and plum, which may help explain the cross-reactivity seen with stone fruits in latex-allergic healthcare workers.

### *Hev b 13 (Latex Esterase)*

The biologic role of this protein is not as well defined, but it is one of the major allergens found in natural and finished latex products to which healthcare workers react. This important allergen correlates well with the allergenic content of finished latex gloves and has been proposed to be one of four allergens used in a standard to measure immunologic allergenic content of manufactured products.<sup>68</sup>

## IMMUNE RESPONSES TO COMMON ENZYMES AND STRUCTURAL PROTEINS

### *Hev b 5*

A proline-rich protein with a 46% amino acid sequence homology to an 18.9 kDa acidic protein from kiwi, Hev b 5 has been cloned and expressed with a molecular mass of 16 kDa.<sup>68,69</sup> It is presumed to be partially responsible for clinical reactions to kiwi in LA patients. This protein is a major allergen with strong IgE-binding reactivity in both healthcare workers (92%) and SB (56%) patients.

### *Hev b 8 (Profilin)*

Profilin, an actin binding protein, is involved in the formation of the actin network of plant exoskeleton. Purified latex profilin, when used in skin prick testing, showed positive reactions in 100% (24/24) of SB patients and 6/17 healthcare workers with LA, but its role in the clinical induction of symptoms is unclear, due to carbohydrate binding in vitro.<sup>70-73</sup>

### *Hev b 9 (Enolase)*

A high degree of cross-reactivity can be expected because of the homology of enolases present in different organisms. However, unpublished work from our laboratory on sera from 26 healthcare workers with LA failed to demonstrate any IgE binding with the recombinant latex Hev b 9 and fungal enolases.

### *Hev b 10 (Manganese Superoxide Dismutase)*

This highly conserved enzyme (MnSOD) has been reported from a number of fungi and bacteria, as well as from human beings, but its role in cross-reactive allergenicity is unclear.<sup>37,38,41,64</sup>

## Diagnosis of Latex Allergy

The diagnosis of LA in a patient requires a medical provider to take a complete medical history, perform a physical

examination and then supplement the clinical conclusions with appropriate testing. An algorithm that outlines one method of approaching the diagnosis is shown in [Figure 56-2](#). Epicutaneous skin testing or serologic testing for antilatax IgE in the absence of a clinical history and physical exam is inadequate for an accurate diagnosis of LA, since each of those tests has variable sensitivity, specificity, positive predictive values and negative predictive values. Testing for LA has been hindered in the USA by lack of a standard reagent clearance through the US Food and Drug Administration (FDA).

## SKIN TESTING

Skin testing has been the most sensitive and predictive test for confirming a diagnosis.<sup>11,74-77</sup> Achieving the highest sensitivity has required the use of more than one source material for latex (e.g. natural latex nonammoniated and a latex glove extract).<sup>11,75</sup> In one series using two source materials, the sensitivity was 100%, specificity 99%, and a negative test had 100% predictive value in concluding that a patient was not allergic to latex.<sup>11</sup> Failure of a skin test reagent to be approved in the USA may relate to the frequency of adverse reactions to epicutaneous testing with latex allergen.<sup>11,74,78</sup> Early information demonstrated that skin testing resulted in a high rate of systemic reactions not seen with other allergens approved for skin testing. This high rate of reaction was confirmed in a comparative retrospective study from the Mayo Clinic where the rate of systemic reactions to latex was 228/100,000 latex skin tests, while the rate of reactions of this nature to other allergens was 72/100,000 penicillin skin tests and 23/100,000 aeroallergen tests.<sup>78</sup> This represents a 10-fold elevated risk of systemic reactions to latex skin testing in comparison to aeroallergen tests. Even the multicenter skin test study with cloned latex resulted in 16% of subjects having systemic, albeit mild, reactions to skin testing.<sup>74</sup> Comparisons of latex extracts made using different techniques indicated that the protein content obtained from a latex glove can vary widely, depending on the extraction method.<sup>75</sup> In addition, the stability of the different latex antigens is variable. The antigen content of gloves can vary several 100-fold, therefore nonstandardized extracts may contain vastly different amounts of latex protein. Some of the risk associated with latex skin tests can be attributed to uncharacterized extracts. Although the algorithm in [Figure 56-2](#) recommends skin testing, it may be safest to perform such tests with a commercial latex standardized reagent such as the Stallergenes S.A. (Marseilles, France) used in Europe.

## IN VITRO TESTING FOR LATEX ALLERGY

Detection of antilatax IgE in serum of patients has been the most widely accepted testing method in the USA.<sup>76,78-83</sup> Tests include research laboratory prepared enzyme linked immunosorbent assays (ELISA) or commercial tests from Pharmacia, UniCAP FEIA (Pharmacia, Peapack, NJ), AlaSTAT (Diagnostic Products Corporation, Los Angeles, CA) and Hycor HYTECH (Hycor Biomedical, Inc., Garden Grove, CA) systems.

Comparative performance of the three commercially available serologic assays for latex-specific IgE was studied in 117 clinically allergic individuals and 195 clinically nonallergic controls. When compared to skin test, both the Pharmacia CAP and AlaSTAT had similar sensitivities of 76% and 73% respectively with 97% specificity. Unfortunately, 25% of the latex-sensitized

## Algorithm for Diagnosed Immediate Hypersensitivity in Latex Allergy

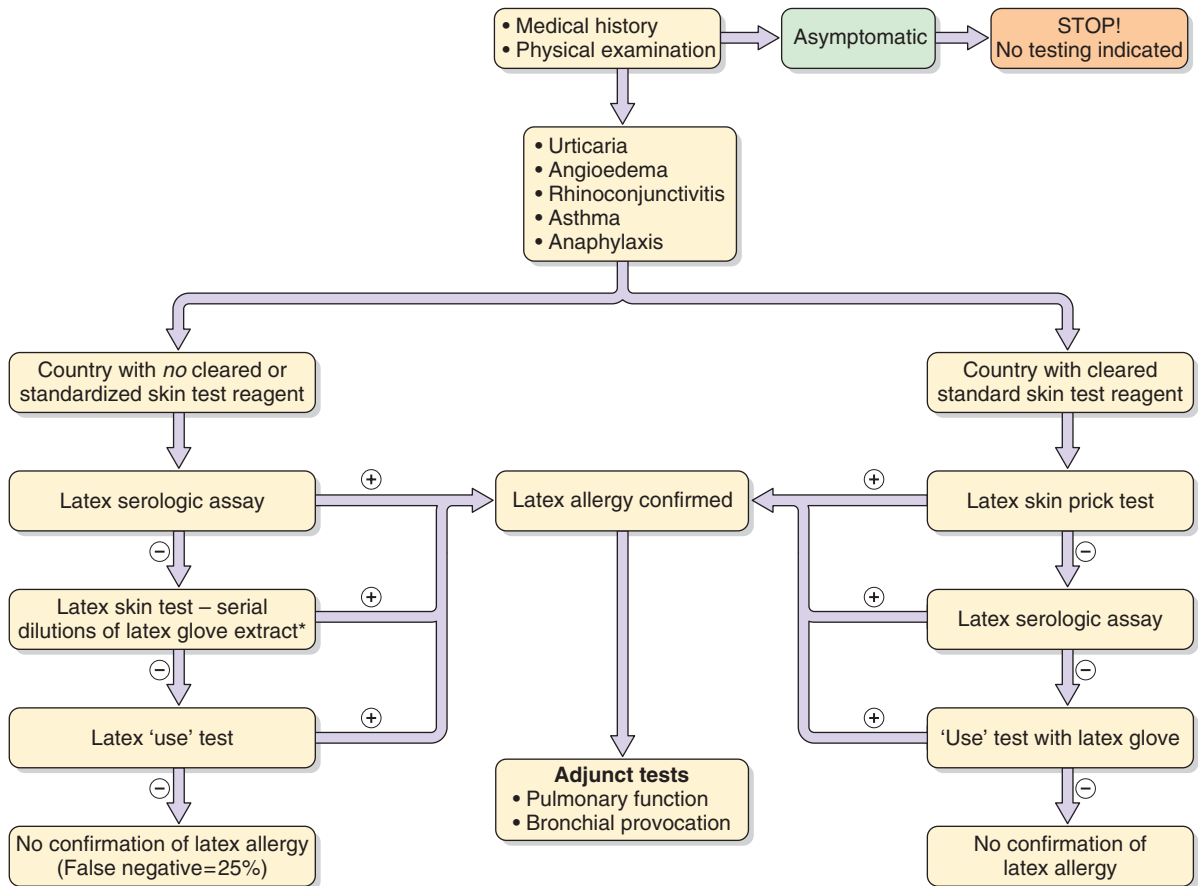

\* Latex skin tests and latex 'use' tests, especially with unstandardized latex, may result in anaphylaxis

**Figure 56-2** This algorithm outlines the common decision analysis for the diagnosis of latex allergy. Countries that lack an FDA cleared skin test reagent, such as the USA, are significantly hindered from making a diagnosis, especially with a 25% rate of false-negative serologic assays. Patients with histories and physical examinations inconsistent with latex allergy should not undergo testing. This is due to the high rate of false-positive serologic assays in populations with a low prevalence of disease.

cases had false-negative results. HyTECH had a significantly lower specificity of 73%, which indicates that 27% of the positive results are erroneous.<sup>79</sup> Thus, screening studies for LA in a population with a low prevalence of disease may result in a significant number of false-positive reactions. In addition, 25% of patients with disease may have a false-negative test. These characteristics make these tests undesirable for screening without a follow-up definitive test. Analysis of the three available methods performed using an unselected at-risk group of patients determined that the FDA-cleared Pharmacia CAP sensitivity was lower than reported, and that this method should only be used for confirmation of LA, not screening.<sup>84</sup>

Other *in vitro* methods of diagnosing LA have included basophil histamine release, CD63 activation of basophils and lymphocyte proliferation methods.<sup>85–87</sup> These assays are more specific but lack sensitivity. Their most useful activity has been to identify specific IgE epitopes and T cell epitopes. These tests have not become useful clinical tools although genetic altering of strongly allergenic epitopes may be useful in down-regulating and inducing tolerance by immunotherapy in latex-allergic subjects.<sup>88</sup>

## IN VIVO PROVOCATION TESTING

In addition to using serologic testing or skin prick testing in diagnosing LA, it is sometimes necessary to understand whether a specific allergen or latex product reported by the clinical history is truly responsible for the symptoms, or to clarify discordant serum and skin test results. Provocation tests for diagnosing LA have included 'glove use tests', utilizing standardized gloves as described in the multicenter latex skin test study.<sup>81</sup> In addition, multiple investigations have used a 'latex glove wearing' test with or without a coupled inhalation test. The critical value of the provocation test is making certain that objective measurable or observable reactions are measured.<sup>89</sup> These may include such things as urticaria, angioedema or pulmonary function changes.

Some investigators have used inhalation provocation challenges alone or mucous membrane allergen contact. These have been progressive, graded challenges and are currently only standardized in research settings. Assuring standard allergen content in the provocation may be helped by the LEAP<sup>®</sup> assay or equivalent.<sup>90</sup>



## Prevention and Treatment of the Patient with Latex Allergy

Prevention of LA has focussed on avoidance strategies for children who have SB, individuals who require multiple surgeries, and workers in health care and other occupations that require contact with natural rubber latex gloves.<sup>91–97</sup> The prototype patient for prevention of LA is the infant born with SB. Avoidance measures include complete abstinence from use of latex materials in the care of these patients from birth. This means preventing contact with latex gloves, catheters, dressings, tape or other medical devices that contain latex in the hospital and home setting. Given the level of disability and the vast number of surgeries in these subjects, an opinion article to vastly change care and prevent LA was published in 1996. Over 40,000 devices and materials contained natural rubber latex as a component, therefore stopping all use of latex-containing materials became impractical. Avoiding the use of latex materials that were made by a dipping process with short vulcanization times and low heat was the most likely strategy to prevent allergic reactions. Indeed, the concept of ‘latex-safe’ environments vs ‘latex-free’ environments turned out to be safe, practical and ideal for patients with LA.

Further observations in Canada, Europe and the USA noted that airborne latex was created by cornstarch donning powder

from latex gloves which continued to sensitize and cause allergic reactions, not only in patients but also in healthcare workers.<sup>93–97</sup> This has led to a change in manufacturing and possibly in the prevalence of LA in healthcare workers through powder-free glove use, reduced airborne latex exposure and reduction in product allergen content.

The care of the patient with LA requires that individuals avoid personal contact of the skin and mucous membranes with latex materials. In addition, they should only enter areas where airborne latex allergen is controlled by use of nonpowdered latex products. If the individuals are healthcare workers, they should use nonlatex gloves and only work in areas where either powder-free latex gloves are used routinely or nonlatex gloves are used.

Rarely, immunotherapy is a consideration for the cure of LA. However, the side-effects of such therapy, length of time to achieve tolerance and lack of a standardized reagent make this therapy relatively futile.<sup>98,99</sup> The promise of modified allergens to make immunotherapy safer and more effective is on the horizon.<sup>88</sup>

The complete reference list can be found on the companion Expert Consult website at <http://www.expertconsult.inkling.com>.



## KEY REFERENCES

- Kelly KJ, Pearson ML, Kurup VP, Havens PL, Byrd RS, Setlock MA, et al. A cluster of anaphylactic reactions in children with spina bifida during general anesthesia: epidemiologic features, risk factors, and latex hypersensitivity. *J Allergy Clin Immunol* 1994;94:53–61.
- Kelly KJ, Kurup V, Zacharisen M, Resnick A, Fink JN. Skin and serologic testing in the diagnosis of latex allergy. *J Allergy Clin Immunol* 1993;91:1140–5.
- Liss GM, Sussman GL, Deal K, Brown S, Cividino M, Siu S, et al. Latex allergy: epidemiological study of 1351 hospital workers. *Occup Environ Med* 1997;54:335–42.
- Wang WL, Kelly KJ, Klancnik M, Petsonk EL. Self-reported hand symptoms: a role in monitoring health care workers for latex sensitization? *Ann Allergy* 2012;109:314–18.
- Kelly KJ, Wang ML, Klancnik M, Petsonk EL. Prevention of IgE sensitization to latex in health care workers after reduction of antigen exposures. *J Occup Environ Med* 2011;53:934–40.
- Blanco C, Carrillo T, Castillo R, Quirarte J, Cuevas M. Latex allergy: clinical features and cross reactivity with fruits. *Ann Allergy* 1994;73:309–14.
- Beezhold DH, Reschke JE, Allen JH, Kostyal DA, Sussman GL. Latex protein: a hidden ‘food’ allergen. *Allergy Asthma Proc* 2000;21:301–6.
- Subramaniam A. The chemistry of natural rubber latex. In: Fink JN, editor. *Immunology and allergy clinics of North America*. Philadelphia: W.B. Saunders; 1995. p. 1–20.
- Acetta DJ, Klancnik M, Elms N, Wang ML, Hoffmann RG, Kurup VP, et al. Analysis of available diagnostic tests for latex sensitization in an at-risk population. *Ann Allergy Asthma Immunol* 2012;108:94–7.
- Ebo D, Lechkar B, Schuerwegh A, Bridts CH, De Clerck LS, Stevens WJ. Validation of a two-color flow cytometric assay detecting in vitro basophil activation for the diagnosis of IgE-mediated natural rubber latex allergy. *Allergy* 2002; 57:706–12.

## REFERENCES

- Stern G. Ueberempfindlichkeit gegen Kautschuk als Ursache von Urticaria und Quinckeschem Ödem. *Klin Wochenschr* 1927;6:1096–7.
- Nutter AF. Contact urticaria to rubber. *Br J Dermatol* 1979;101:597–8.
- Forstrom L. Contact urticaria from latex surgical gloves. *Contact Dermatitis* 1980;16:33–4.
- Turjanmaa K. Incidence of immediate allergy to latex gloves in hospital personnel. *Contact Dermatitis* 1987;17:270–5.
- Axelsson JGK, Johansson SGO, Wrangsjö K. IgE-mediated anaphylactoid reactions to rubber. *Allergy* 1987;42:46–50.
- Seaton A, Cherrie B. Rubber glove asthma. *Br Med J* 1988;296:531–2.
- Slater J. Rubber anaphylaxis. *N Eng J Med* 1989;320:1126–30.
- Kelly KJ, Setlock M, Davis JP. Anaphylactic reactions during general anesthesia among pediatric patients. *MMWR* 1991;40:437.
- Gold M, Swartz J, Braude B, Dolovich J, Shandling B, Gilmour RE. Intraoperative anaphylaxis: an association with latex sensitivity. *J Allergy Clin Immunol* 1991;87:662–6.
- Kelly KJ, Pearson ML, Kurup VP, Havens PL, Byrd RS, Setlock MA, et al. A cluster of anaphylactic reactions in children with spina bifida during general anesthesia: epidemiologic features, risk factors, and latex hypersensitivity. *J Allergy Clin Immunol* 1994;94:53–61.
- Kelly KJ, Kurup V, Zacharisen M, Resnick A, Fink JN. Skin and serologic testing in the diagnosis of latex allergy. *J Allergy Clin Immunol* 1993;91:1140–5.
- Hourihane JO, Allard MN, Wade AM, McEwan AI, Strobel S. Impact of repeated surgical procedures on the incidence and prevalence of latex allergy: a prospective study of 1263 children. *J Pediatr* 2002;140:479–82.
- Nieto A, Externell F, Mazon A, Reig C, Nieto A, Garcia-Ibarra F. Allergy to latex in spina bifida: a multivariate study of associated factors in 100 consecutive patients. *J Allergy Clin Immunol* 1996;98:501–7.
- Cremer R, Hoppe A, Korsch E, Kleine-Diepenbruck U, Blaker F. Natural rubber latex allergy: prevalence and risk factors in patients with spina bifida compared with atopic children and controls. *Eur J Pediatr* 1998;157:13–16.
- Bernardini R, Novembre E, Lombardi E, Mezzetti P, Cianferoni A, Danti DA, et al. Risk factors for latex allergy in patients with spina bifida and latex sensitization. *Clin Exp Allergy* 1999;29:681–6.
- Blumchen K, Bayer P, Michael T, Michael T, Cremer R, Fricke C, et al. Effects of latex avoidance on latex sensitization, atopy and allergic diseases in patients with spina bifida. *Allergy* 2010;65:1585–93.
- Konz KR, Chia JK, Kurup VP, Resnick A, Kelly KJ, Fink JN. Comparison of latex hypersensitivity among patients with neurologic defects. *J Allergy Clin Immunol* 1995;95:950–4.
- Vogel LC, Schrader T, Lubicky JP. Latex allergy in children and adolescents with spinal cord injuries. *J Pediatr Orthop* 1995;15:517–20.
- Tarlo S, Sussman G, Holness D. Latex sensitivity in dental students and staff: a cross-sectional study. *J Allergy Clin Immunol* 1997;99:396–401.
- Kelly KJ, Walsh-Kelly CM. Latex allergy: a patient and health care system emergency. *Ann Emerg Med* 1998;32:723–9.
- Liss GM, Sussman GL, Deal K, Brown S, Cividine M, Siu S, et al. Latex allergy: epidemiological study of 1351 hospital workers. *Occup Environ Med* 1997;54:335–42.
- Lagier F, Vervloet D, Lhermet I, Poyen D, Charpin D. Prevalence of latex allergy in operating room nurses. *J Allergy Clin Immunol* 1993;90:319–22.
- Yassin MS, Lierl MB, Fischer TJ, O'Brien K, Cross J, Steinmetz C. Latex allergy in hospital employees. *Ann Allergy* 1994;72:245–9.
- Wang WL, Kelly KJ, Klancnik M, Petsonk EL. Self-reported hand symptoms: a role in monitoring health care workers for latex sensitization? *Ann Allergy* 2012;109:314–18.
- Kelly KJ, Wang ML, Kancnik M, Petsonk EL. Prevention of IgE sensitization to latex in health care workers after reduction of antigen exposures. *J Occup Environ Med* 2011;53:934–40.
- Ylitalo L, Turjanmaa K, Palosuo T, Reunala T. Natural rubber latex allergy in children who had not undergone surgery and children who had undergone multiple operations. *J Allergy Clin Immunol* 1997;100:606–12.
- Owby DR, Tomlanovich M, Sammons N, McCullough J. Anaphylaxis associated with latex allergy during barium enema examinations. *Am J Radiol* 1991;156:903–8.
- Schwartz EE, Glick SN, Foggs MB, Silverstein GS. Hypersensitivity reactions after barium enema examination. *AJR Am J Roentgenol* 1984;143:103–4.
- Bernardini R, Novembre E, Ingargiola A, Veltroni M, Mugnaini L, Cianferoni A, et al. Prevalence and risk factors of latex sensitization in an unselected pediatric population. *J Allergy Clin Immunol* 1998;101:621–5.
- Levenbom-Mansour MH, Oesterle JR, Ownby DR, Jennett MK, Post SK, Zaglaniczny K. The incidence of latex sensitivity in ambulatory surgical patients: a correlation of historical factors with positive serum IgE levels. *Anesth Analg* 1997;85:44–9.
- Reinheimer G, Ownby DR. Prevalence of latex-specific IgE antibodies in patients being evaluated for allergy. *Ann Allergy Asthma Immunol* 1995;74:184–7.
- Ownby DR, Ownby HEB, McCullough JA, Shafer AW. The prevalence of anti-latex IgE antibodies to natural rubber latex in 1,000 volunteer blood donors. *J Allergy Clin Immunol* 1996;97:1188–92.
- Gryzbowski M, Ownby DR, Rivers EP, Ander D, Nowak RM. The prevalence of latex-specific IgE in patients presenting to an urban emergency department. *Ann Emerg Med* 2002;40:411–19.
- Liss GM, Sussman GL. Latex sensitization: occupational versus general population prevalence rates. *Am J Ind Med* 1999;35:196–200.
- Blanco C, Carrillo T, Castillo R, Quiralte J, Cuevas M. Latex allergy: clinical features and cross reactivity with fruits. *Ann Allergy* 1994;73:309–14.
- Kurup VP, Kelly T, Elms N, Kelly K, Fink J. Cross reactivity of food allergens in latex allergy. *Allergy Proc* 1994;15:211–16.
- Yagami T. Defense-related proteins as families of cross-reactive plant allergens. *Recent Res Devel Allergy & Clin Immunol* 2000;1:41–64.
- Brehler R, Theissen U, Mohr C, Luger T. 'Latex fruit syndrome' frequency of cross-reacting IgE antibodies. *Allergy* 1997;52:404–10.
- Beezhold DH, Sussman GL, Liss GM, Chang NS. Latex allergy can induce clinical reactions to specific foods. *Clin Exp Immunol* 1996;26:416–22.
- Ahlroth M, Alenius H, Turjanmaa K, Madkinen-Kiljunen S, Reunala T, Palosuo T. Cross-reacting allergens in natural rubber latex and avocado. *J Allergy Clin Immunol* 1995;96:167–73.
- Breiteneder H, Ebner C. Molecular and biochemical classification of plant-derived food allergens. *J Allergy Clin Immunol* 2000;106:27–36.
- Alenius H, Kalkkinen N, Reunala T, Turjanmaa K, Palosuo T. The main IgE-binding epitope of a major latex allergen, prohevein, is present in its N-terminal 43-amino acid fragment, hevein. *J Immunol* 1996;156:1618–25.
- Banerjee B, Wang X, Kelly KJ, Fink JN, Sussman GL, Kurup VP. IgE from latex-allergic patients binds to cloned and expressed B cell epitopes of prohevein. *J Immunol* 1997;159:5724–32.
- Breiteneder H. The allergens of *Hevea brasiliensis*. *ACI International* 1998;10:101–9.
- Garcia Ortiz JC, Moyano JC, Alvarez M, Bellido J. Latex allergy in fruit allergic patients. *Allergy* 1998;53:532–6.
- Schwartz HJ. Latex: a potential hidden 'food' allergen in fast food restaurants. *J Allergy Clin Immunol* 1995;95:139–40.
- Beezhold DH, Reschke JE, Allen JH, Kostyal DA, Sussman GL. Latex protein: a hidden 'food' allergen. *Allergy Asthma Proc* 2000;21:301–6.
- Vassallo SA, Thurston TA, Kim SH, Todres ID. Allergic reaction to latex from stopper of a medication vial. *Anesth Analg* 1995;80:1057–8.
- Towse A, O'Brien M, Twarog FJ, Braimon J, Moses AC. Local reaction secondary to insulin injection: a potential role for latex antigens in insulin vials and syringes. *Diabetes Care* 1995;18:1195–7.
- Roest MA, Shaw S, Orton DI. Insulin-injection-site reactions associated with type I latex allergy. *N Engl J Med* 2003;348:265–6.
- Thomsen DJ, Burke TG. Lack of latex allergen contamination of solutions withdrawn from vials with natural rubber stoppers. *Am J Health Syst Pharm* 2000;57:44–7.
- Danne T, Niggemann B, Weber B, Wahn U. Prevalence of latex specific IgE antibodies in atopic and nonatopic children with type 1 diabetes. *Diabetes Care* 1997;20:476–8.
- Makinen-Kiljunen S, Turjanmaa K, Palosuo T, Reunala T. Characterization of latex antigens and allergens in surgical gloves and natural rubber by immunoelectrophoretic methods. *J Allergy Clin Immunol* 1992;90:230–5.
- Subramaniam A. The chemistry of natural rubber latex. In: Fink JN, editor. *Immunology and allergy clinics of North America*. Philadelphia: W.B. Saunders; 1995. p. 1–20. <http://www.madehow.com/Volume-3/Latex.html>; [accessed 20 May 2007].
- Burger K. The changing outlook for natural rubber. In: *Natural rubber* (Newsletter of the Rubber Foundation Information Center for Natural Rubber). Eindhoven: 2005;40:1–2.
- Ownby DR. A history of latex allergy. *J Allergy Clin Immunol* 2002;110:S27–32.
- Chen ZP, Cremer R, Posch A, Raulf-Heimsoth M, Rihs HP, Baur X. On the allergenicity of Hev b 1 among health care workers and patients with spina bifida allergic to natural rubber latex. *J Allergy Clin Immunol* 1997;100:684–93.

59. Kurup VP, Yeang HY, Sussman GL, Bansal NK, Beezhold DH, Kelly KJ, et al. Detection of immunoglobulin antibodies in the sera of patients using purified latex allergens. *Clin Exp Allergy* 1999;30:359–69.
60. Alenius H, Palosuo T, Kelly K, Kurup V, Reunala T, Makinen-Kiljunen S, et al. IgE reactivity to 14-kD and 27-kD natural rubber proteins in latex-allergic children with spina bifida and other congenital anomalies. *Int Arch Allergy Immunol* 1993;102:61–6.
61. Banerjee B, Kanitpong K, Fink JN, Zussman M, Sussman GL, Kelly KJ, et al. Unique and shared IgE epitopes of Hev b 1 and Hev v 3 in latex allergy. *Mol Immunol* 2000;37:789–98.
62. Beezhold DH, Sussman GL, Kostyal DA, Chang NS. Identification of a 46-kD latex protein allergen in health care workers. *Clin Exp Immunol* 1994;98:408–13.
63. Breton F, Coupe M, Sanier C, et al. Demonstration of beta-1,3-glucanase activities in lutoids of *Hevea brasiliensis* latex. *J Nat Rubb Res* 1995; 10:37–45.
64. Yagami T, Sato M, Nakamura A, Komiyama T, Kitagawa K, Akasawa A, et al. Plant defense-related enzymes as latex antigens. *J Allergy Clin Immunol* 1998;101:379–85.
65. Johnson BD, Kurup VP, Sussman GL, Arif SA, Kelly KJ, Beezhold DH, et al. Purified and recombinant latex proteins stimulate peripheral blood lymphocytes of latex allergic patients. *Int Arch Allergy Immunol* 1999;120:270–9.
66. Wagner S, Radauer C, Hafner C, Fuchs H, Jensen-Jarolim E, Wuthrich B, et al. Characterization of cross-reactive bell pepper allergens involved in the latex-fruit syndrome. *Clin Exp Allergy* 2004;34:1739–46.
67. Fernández-Rivas M, Benito C, González-Mancebo E, de Durana DA. Allergies to fruits and vegetables. *Pediatr Allergy Immunol* 2008; 19:675–81.
68. Yeang H, Arif SAM, Raouf-Heimsouth M, Loke YH, Sander I, Sulong SH, et al. Hev b 5 and Hev b 13 as allergen markers to estimate the allergenic potency of latex gloves. *J Allergy Clin Immunol* 2004;114:593–8.
69. Slater JE, Vedvick T, Arthur-Smith A, Trybul DE, Kekwick RG. Identification, cloning, and sequence of a major allergen (Hev b 5) from natural rubber latex (*Hevea brasiliensis*). *J Biol Chem* 1996;271:25394–9.
70. Yagami A, Nakazawa Y, Suzuki K, Matsunaga K. Curry spice allergy associated with pollen-food allergy syndrome and latex fruit-syndrome. *J Dermatol* 2009;36:45–9.
71. Raulf-Heimsoth M, Kespohl S, Crespo JF, Rodriguez J, Felio A, Bruning T, et al. Natural rubber latex and chestnut allergy: cross-reactivity or co-sensitization? *Allergy* 2007;62: 1277–81.
72. Ebo DG, Hagendorens MM, Bridts CH, De Clerck LS, Stevens WJ. Sensitization to cross-reactive carbohydrate determinants and the ubiquitous protein profilin: mimickers of allergy. *Clin Exp Allergy* 2004;34:137–44.
73. Nieto A, Mazon A, Boquete M, Carballada F, Asturias JA, Martinez J, et al. Assessment of profilin as an allergen for latex-sensitized patients. *Allergy* 2002;57:776–84.
74. Hamilton RG, Adkinson NF Jr. Multicenter latex skin testing study task force: Diagnosis of natural rubber latex allergy: multicenter latex skin testing efficacy study. *J Allergy Clin Immunol* 1998;102:482–90.
75. Fink JN, Kelly KJ, Elms N, Kurup VP. Comparative studies of latex extracts used in skin testing. *Ann Allergy Asthma Immunol* 1996;76:149–52.
76. Kelly K, Kurup V, Reijula K, Fink JN. The diagnosis of natural rubber latex allergy. *J Allergy Clin Immunol* 1994;93:813–16.
77. Hamilton R, Peterson E, Ownby D. Clinical and laboratory-based methods in the diagnosis of natural rubber latex allergy. *J Allergy Clin Immunol* 2002;110:547–56.
78. Valyasevi MA, Maddox DE, Li JT. Systemic reactions to allergy skin tests. *Ann Allergy Asthma Immunol* 1999;83:132–6.
79. Hamilton RG, Biagini RE, Krieg EF. Multi-center latex skin testing study task force: Diagnostic performance of FDA-cleared serological assays for natural rubber latex-specific IgE antibody. *J Allergy Clin Immunol* 1999;103:925–30.
80. Ownby D, McCullough J. Testing for latex allergy. *J Clin Immunol* 1993;16:109–13.
81. Biagini R, Krieg E, Pinkerton L, Hamilton RG. Receiver operating characteristics analyses of Food and Drug Administration-cleared serological assays for natural rubber latex-specific immunoglobulin E antibody. *Clin Diagn Lab Immunol* 2001;8:1145–9.
82. Lundberg M, Chen Z, Rihs HP, Wrangsjö K. Recombinant spiked allergen extracts. *Allergy* 2001;56:794–5.
83. Ownby D, Magera B, Williams P. A blinded, multi-center evaluation of two commercial in vitro tests for latex-specific IgE antibodies. *Ann Allergy Asthma Immunol* 2000;84:193–6.
84. Acetta DJ, Klančnik M, Elms N, Wang ML, Hoffmann RG, Kurup VP, et al. Analysis of available diagnostic tests for latex sensitization in an at-risk population. *Ann Allergy Asthma Immunol* 2012;108:94–7.
85. Turjanmaa K, Rasanen L, Lehto M, Makinen-Kiljunen S, Reunala T. Basophil histamine release and lymphocyte proliferation tests in latex contact urticaria. *Allergy* 1989;44:181–6.
86. Ebo D, Lechkar B, Schuerwegh A, Bridts CH, De Clerck LS, Stevens WJ. Validation of a two-color flow cytometric assay detecting in vitro basophil activation for the diagnosis of IgE-mediated natural rubber latex allergy. *Allergy* 2002;57:706–12.
87. Murali P, Kelly K, Fink J, Kurup VP. Investigations into the cellular immune responses in latex allergy. *J Lab Clin Med* 1994;124:638–43.
88. Karisola P, Mikkola J, Kalkkinen N, Airenne KJ, Laitinen OH, Repo S, et al. Construction of hevein (Hev b 6.02) with reduced allergenicity for immunotherapy of latex allergy by comutation of six amino acid residues on the conformational IgE epitopes. *J Immunol* 2004;172: 2621–8.
89. Kurtz KM, Hamilton RG, Schaefer JA, Adkinson NF. A hooded exposure chamber method for semi-quantitative latex aeroallergen challenge. *J Allergy Clin Immunol* 2001;107:178–84.
90. Beezhold D. LEAP: Latex ELISA for Antigenic Proteins ©\* preliminary report. *Guthrie Journal* 1992;61:77–81.
91. Kelly KJ, Sussman G, Fink JN. Stop the sensitization. *J Allergy Clin Immunol* 1996;98:857–8.
92. Committee Report. Task force on allergic reactions to latex. (Committee Members: Slater J, Abramson S, Graft D, Honsinger R, Kelly K, Kwittken P, Ownby D, Virant F.) *J Allergy Clin Immunol* 1993;92(1 Pt 1):16–18.
93. Baur X, Ammon J, Chen Z, Beckmann U, Czuppon AB. Health risk in hospitals through airborne allergens for patients presensitized to latex. *Lancet* 1993;342:1148–9.
94. Tarlo S, Sussman G, Contala A, Swanson MC. Control of airborne latex by use of powder-free latex gloves. *J Allergy Clin Immunol* 1994;93: 985–9.
95. Kelly KJ. Management of the latex allergy patient. In: Fink JN, editor. *Immunology and allergy clinics of North America*. Philadelphia: W.B. Saunders; 1995. p. 139–57.
96. Baur X, Chen Z, Allmers H. Can a threshold limit value for natural rubber latex airborne allergens be defined? *J Allergy Clin Immunol* 1998;101(1 Pt 1):24–7.
97. Allmers H, Schmengler J, Skudlik C. Primary prevention of natural rubber latex allergy in the German health care system through education and intervention. *J Allergy Clin Immunol* 2002; 110:318–23.
98. Nettis E, Colanardi MC, Soccio AL, Marcandrea M, Pinto L, Ferrannini A, et al. Double-blind, placebo-controlled study of sublingual immunotherapy in patients with latex-induced urticaria: a 12-month study. *Br J Dermatol* 2007; 156:674–81.
99. Sastre J, Fernandez-Nieto M, Rico P, Martin S, Barber D, Cuesta J, et al. Specific immunotherapy with a standardized latex extract in allergic workers: a double-blind, placebo-controlled study. *J Allergy Clin Immunol* 2003; 111:985–94.

# Insect Sting Allergy

HANNEKE (JOANNE) N.G. OUDE ELBERINK

## KEY POINTS

- The majority of insect sting reactions in children are mild and frequently only dermal (hives, angioedema).
- Children who have only dermal reactions have a very benign prognosis and generally do not retain their allergic sensitivity.
- Children with more severe reactions have a 30% to 40% risk of recurrent anaphylaxis.
- Venom immunotherapy (VIT) provides more than 95% protection against subsequent re-sting reactions in children, and if there are reactions, they are milder.
- For most individuals, 3 to 5 years of therapy appears adequate despite the persistence of specific IgE.
- VIT is associated with an improvement in quality of life in contrast to use of an epinephrine autoinjector (EAI).
- In children, the prescription of an EAI should carefully take into account the risks of the disease versus the risks of having an EAI (diminished quality of life) versus the benefits (preparedness for treating a potentially life-threatening event).

## Introduction

Allergic reactions to insect stings are common. An allergic reaction can occur at any age, often after a number of uneventful stings. It is estimated to affect at least 0.3% to 3% of the population.<sup>1</sup> The severity of the reaction ranges from a local reaction to anaphylaxis. Children tend to suffer from less serious reactions, a large local reaction being the most common presentation in this age group. The incidence of insect anaphylaxis in children is estimated to constitute 0.3% to 1.0% of all cases of childhood anaphylaxis, in contrast to adults where anaphylaxis to insect stings makes up 3% to 34% of all adult anaphylaxis cases. Stinging insect allergy is responsible for considerable anxiety that is detrimental to lifestyle.

This chapter reviews the general concepts relating to insect sting allergy and, in particular, addresses those aspects that are more relevant to children.

## The Insects

Biting insects are different to stinging insects. The former primarily cause reactions due to the saliva they inject when feeding, while stinging insects inject venom with the stinging apparatus at the back of their abdomen. Salivary gland secretions have no relation to venom allergens. While the venom of a sting typically causes an intense, burning pain, the saliva of a biting insect is

a chemical cocktail of substances designed to make blood flow quickly and painlessly to avoid being squished. Unlike insect stings, insect bites rarely cause anaphylaxis.

## BITING INSECTS

The most common biting insects are mosquitoes, flies, midges, gnats, fleas, ticks and bedbugs.

Itching and a wheal may develop immediately and mostly disappear after about 2 hours, but they are often followed by a small itchy lump (papule) that develops up to 24 hours later and may last for several days before fading away. Large local reactions from mosquito bites are more common in young children.<sup>2</sup> Over time, and with repeated exposure, the reactions become less intense and are less frequent problems in adolescents and adults. Anaphylaxis has been described after the bites of mosquitoes,<sup>3,4</sup> deer flies,<sup>5</sup> bed bugs and black flies.

Mosquito bites may be associated with IgE and perhaps IgG antibodies. Elevated titers correlate with the intensity of the local reactions and appear to be the immunologic mediators responsible for the reactions.<sup>2</sup>

Skeeter syndrome describes a localized (allergic) reaction to mosquito bites masquerading as cellulitis and accompanied by lethargy, fever and general malaise.<sup>2</sup> Skeeter syndrome usually progresses over the course of hours while cellulitis typically will evolve over the course of several days. Diagnosis can therefore be made clinically by the course of the symptoms and can be confirmed by measuring IgE and IgG antibodies to mosquito saliva antigens.

A mild reaction to an insect bite will probably resolve itself within a day or two without any need for treatment. In some cases, the use of a topical steroid may assist in reducing inflammation and an antipruritic may relieve itchiness. There is a scarcity of quantitative scientific studies into the various treatments for insect bite reactions.

## STINGING INSECTS

Insects that sting are members of the order Hymenoptera of the class Insecta. It is almost exclusively the social Aculeata of the families Apidae, Vespidae and Formicidae that cause significant allergic reactions in human beings. Aculeata from other families can cause painful stings to people, but repeated stings from the same species are so unlikely that allergy to them is practically unheard of. There are three major subgroups: Vespidae, which include the yellow jacket, hornet and wasp; Apidae, which include the honeybee and bumblebee; and the Formicidae (Figure 57-1). An overview of the Hymenoptera is given in Figure 57-2.

The Aculeata share in common a stinging apparatus that originates in the abdomen of the female insect and actually is a modified ovipositor; therefore only female insects can sting.



The sting consists of a sac containing venom attached to a barbed stinger. The honeybee's stinger has multiple barbs, which usually cause the stinging apparatus to detach from the insect, leading to its death. In contrast, the stingers of vespids have few and finer barbs than the Apidae, and do not commonly autotomize, so vespids can inflict multiple stings (Figure 57-3).

**Vespidae**

The Vespidae are divided into the subfamilies Vespinae (yellow jackets and hornets) and Polistinae (wasps). The Vespinae are



**Figure 57-1** The common stinging insects. Shown clockwise from the top right portion of the figure are a yellow jacket, honeybee, bumblebee, Polistes wasp and two hornets. (From Reisman RE. *Insect stings*. *N Engl J Med* 1994;331:523-7. Copyright 1994 Massachusetts Medical Society. All rights reserved.)

split into three genera: *Vespula* (yellow jackets), *Dolichovespula* and *Vespa* (hornets). The common names in general usage can be misleading: in Europe the term 'wasps' refers generally to any of the social wasps rather than just to Polistes species (Table 57-1).

In most parts of the USA and Europe, yellow jackets are the principal cause of allergic reactions, whereas Polistes are more commonly implicated in the Gulf Coast areas of the USA and along the Mediterranean coast of Europe. In Australia yellow jackets were only introduced around 20 years ago, but are already found in every state.<sup>6</sup>

The *Vespula* (yellow jackets) preferably build their nests underground, but can also be found under the roof and in window shutters. They live mostly in proximity to humans. Their nests are often encountered by children playing in the garden, or are disturbed by lawn mowing, gardening or other outdoor activities. Yellow jackets are scavengers and are often encountered at outdoor events when food and drinks abound. Most stings occur in summer.<sup>7,8</sup>

TABLE 57-1 Popular Names for Vespids in Europe and the USA		
Genus	Europe	USA
<i>Vespula</i>	Wasp	Yellow jacket
<i>Dolichovespula</i>	Wasp	Hornet, white-faced hornet, aerial yellow jacket
<i>Vespa</i>	Hornet	European hornet
<i>Polistes</i>	Paper wasp	Wasp

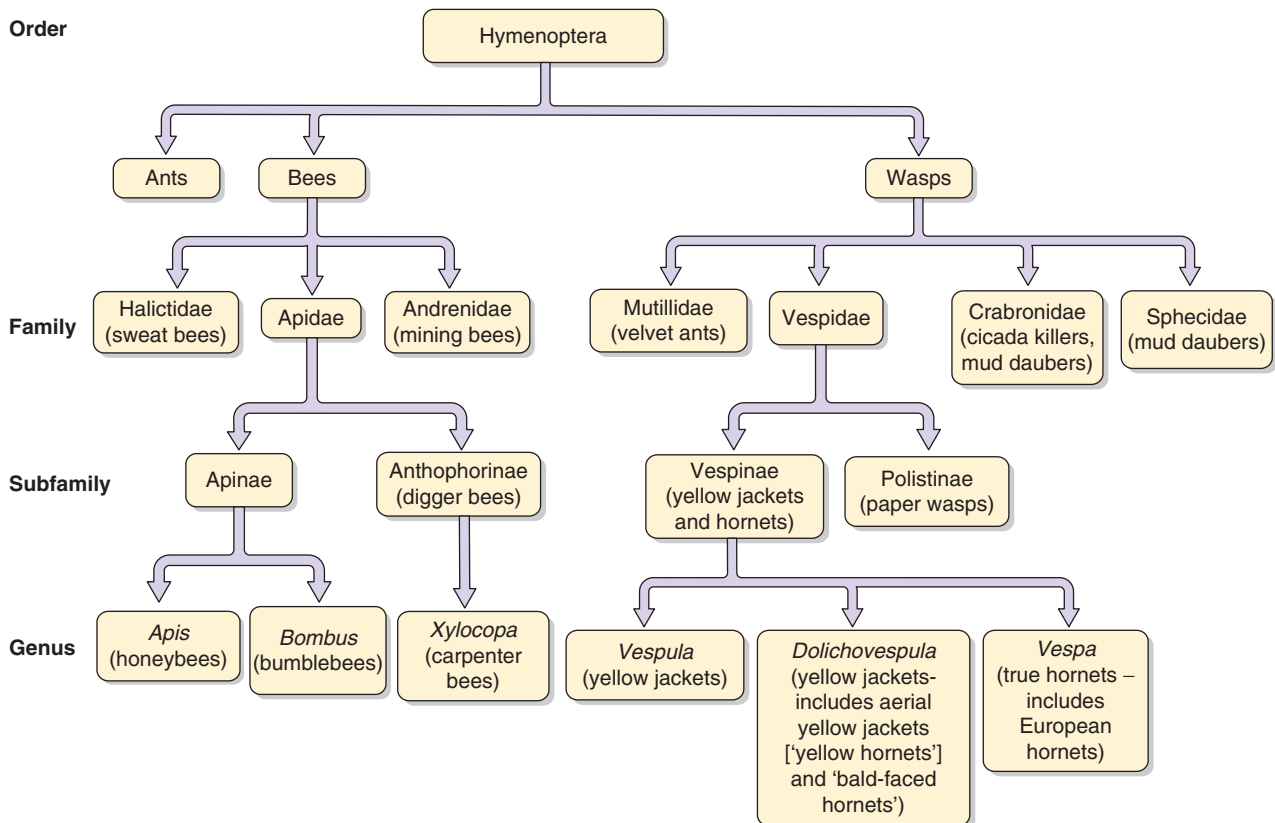

**Figure 57-2** Overview of taxonomy of common Hymenoptera (stinging insects).

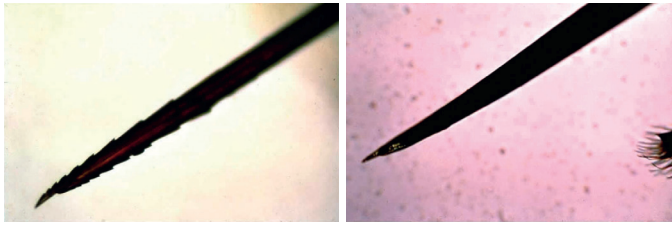

**Figure 57-3** The honeybee stinger on the left has multiple barbs. The yellow jacket stinger on the right is smooth.

*Vespa* include the European hornet (*V. crabro*) which also exists in significant numbers in eastern North America, and the Asian hornet (*V. orientalis*). Hornets nest in shrubs, trees and birds' nest-boxes. Near their nests, hornets are very aggressive. However, they are attracted much less to meat and sweet food-stuffs than the *Vespula*. Therefore hornet stings are rare.

The common paper wasps (*Polistes*) build honeycomb nests in shrubs or under the eaves of houses. Their nests are generally limited to a single layer of open cells (or comb) with minimal outer covering. They are important predators, preying on agricultural and horticultural pests. Important *Polistes* species in Europe are *P. dominula* and *P. gallicus*, whereas in North America other species such as *P. annularis*, *P. apachus*, *P. exclamans*, *P. fuscatus* and *P. metricus* are dominant. In the last decades, *P. dominula* has increasingly spread across the North American continent and central and northern parts of Europe. The coloring of wasps varies greatly: they can be brown, black, red or striped. The European species, the Mediterranean wasp (*P. dominula*), is difficult to distinguish from a yellow jacket because it has the same bright yellow and black stripes. Outwardly they are distinguishable by differences at the junction of thorax and abdomen: the waist becomes thicker more rapidly in the Vespinae compared to the Polistinae and they have characteristic dangling legs when in flight (Figure 57-4). *Polistes* are more prevalent early in the summer season. In some areas of the USA, such as Texas, they are the most frequent cause of sting reactions.

### Apidae

The Apidae are divided into the genera *Apis* (honeybees) and *Bombus* (bumblebees). Honeybees and bumblebees are docile and sting only when provoked. The most significant species in causing allergic reactions is the domesticated *A. mellifera*, cultured all over the world for honey production and to pollinate fruit trees.

Africanized honeybees, or 'killer bees', have received much publicity.<sup>9</sup> They are a cross between the European *A. mellifera mellifera* and the African *A. mellifera adansonii*. They were introduced into Brazil from Africa in 1956 for the purpose of more productive pollination and have gradually spread north into the USA. The venom components of the Africanized honeybees and the domesticated European honeybees are similar. African honeybees are much more aggressive. Massive stinging incidents have occurred, leading to death from venom toxicity.

Members of the genus *Bombus*, the bumblebees, also live in colonies. The nests are usually in the earth. Most bumblebee species are bigger than honeybees, more heavily built and more hairy. Bumblebees are not aggressive; children can incur stings when walking on grass. Systemic reactions occur in particular in owners of greenhouses where bumblebees are kept for pollination of plants (e.g. tomatoes).<sup>10</sup>

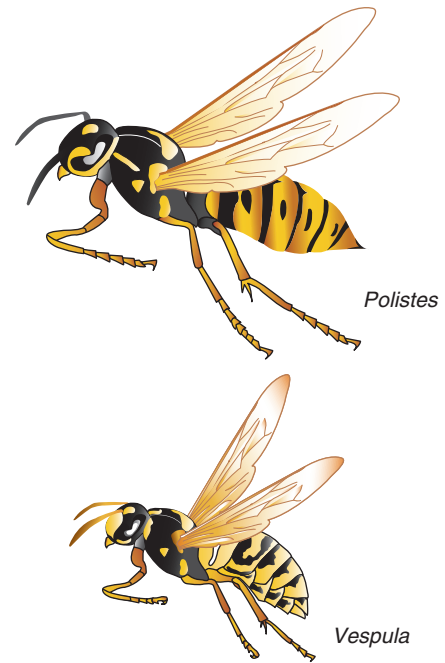

**Figure 57-4** *Polistes* compared to *Vespula*: thicker waist and dangling legs when in flight. (From: <http://crawford.tardigrade.net/bugs/BugofMonth16.html>.)

### Formicids

The family *Formicidae* has a subfamily *Myrmecinae*, which subsequently can be divided in two genera: *Myrmecia* (jack jumper ants [JJA] and bull ants) and *Solenopsis* (imported fire ants [IFA]). *Myrmecia* are solitary roamers, do not appear in ant trails, and attack when aggravated. JJA cause the highest rate of anaphylaxis in the world from a single insect sting/bite.<sup>11</sup>

The main two members of the *Solenopsis* genus are the red fire ant (*S. invicta*) and the black fire ant (*S. richteri*). Fire ants build characteristic nests, which can grow to 40 cm in height, and often migrate in trails.

Red fire ants are found in the southeastern and south central USA, especially along the Gulf Coast. They have now spread to California. In Australia they are only found in Brisbane.

Stings occur most frequently in summer, most commonly in children and typically on the lower extremities. The fire ant attaches itself to a person by biting with its powerful mandibles to hold onto the skin. It then pivots around its head and stings at multiple sites in a circular pattern with the stinger located at the tip of its abdomen. Within 24 hours a sterile pustule develops, which is diagnostic of the fire ant's sting. Allergic reactions to fire ant stings are becoming increasingly common in the southern USA.<sup>12,13</sup>

### Insect Venoms

Venoms contain vasoactive amines (e.g. histamine, dopamine, norepinephrine), acetylcholine and kinins, which account for the burning, pain and itching normally experienced from a sting. They increase permeability, allowing the spread of the venom through the body of the victim. The different venom components known to date are listed in Table 57-2.<sup>14</sup>

The major allergenic components of Hymenoptera venoms are phospholipase A in honeybee venom and antigen 5 in vespids.

TABLE  
57-2

## Overview of the Presently Known Hymenoptera Venom Allergens, Including the Percentage Dry Weight (% DW) and Glycosylation Sites

Allergen	Name/Function	MW (kDa)	% DW	Potential N-Glycosylation	Eukaryotic Expression
<b>BEES (<i>Apis mellifera</i>, <i>A. cerana</i>, <i>A. dorsata</i>)</b>					
Api m 1, Api c 1, Api d 1	Phospholipase A2	17	12	1	+
Api m 2	Hyaluronidase	45	2	3	+
Api m 3	Acid phosphatase	49	1–2	2	+
Api m 4	Melittin	3	50	0	–
Api m 5	Allergen C/DPP IV	100	<1	6	+
Api m 6	Protease inhibitor	8	1–2	0	+
Api m 7	Protease	39	?	3	+
Api m 8	Carboxylesterase	70	?	4	+
Api m 9	Carboxypeptidase	60	?	4	+
Api m 10	CRP/icarapin	55	<1	2	+
Api m 11.0101	MRJP 8	65	?	6	+
Api m 11.0201	MRJP 9	60	?	3	+
Api m 12	Vitellogenin	200	?	1	+
<b>BUMBLEBEE (<i>Bombus pennsylvanicus</i>, <i>B. terrestris</i>)</b>					
Bom p 1, Bom t 1	Phospholipase A2	16		1	–
Bom p 4, Bom t 4	Protease	27		0, 1	–
<b>YELLOW JACKETS (<i>Vespa vulgaris</i>, <i>V. flavopilosa</i>, <i>V. germanica</i>, <i>V. maculifrons</i>, <i>V. pensylvanica</i>, <i>V. squamosa</i>, <i>V. vidua</i>)</b>					
Ves v 1, Ves m 1, Ves s 1	Phospholipase A1	35	6–14	0, 0, 2	+
Ves v 2.0101, Ves m 2	Hyaluronidase	45	1–3	4	+
Ves v 2.0201	Hyaluronidase*	45	?	2	+
Ves v 3	DPP IV	100	?	6	+
Ves v 5, Ves f 5, Ves g 5, Ves m 5, Ves p 5, Ves s 5, Ves vi 5	Antigen 5	25	5–10	0	+
Ves v 6	Vitellogenin	200	?	4	+
<b>WHITE-FACED HORNET, YELLOW HORNET (<i>Dolichovespula maculata</i>, <i>D. arenaria</i>)</b>					
Dol m 1	Phospholipase A1	34		2	–
Dol m 2	Hyaluronidase	42		2	–
Dol m 5, Dol a 5	Antigen 5	23		0	+
<b>HORNETS (<i>Vespa crabro</i>, <i>V. magnifica</i>, <i>V. mandarinia</i>)</b>					
Vesp c 1, Vesp m 1	Phospholipase A1	34		0	–
Vesp ma 2	Hyaluronidase	35		4	–
Vesp c 5, Vesp ma 5, Vesp m 5	Antigen 5	23		0	–
<b>EUROPEAN PAPER WASPS (<i>Polistes dominula</i>, <i>P. gallicus</i>)</b>					
Pol d 1, Pol g 1	Phospholipase A1	34		1	–
Pol d 4	Protease	33		6	–
Pol d 5, Pol g 5	Antigen 5	23		0	–
<b>AMERICAN PAPER WASPS (<i>Polistes annularis</i>, <i>P. exclamans</i>, <i>P. fuscatus</i>, <i>P. metricus</i>)</b>					
Pol a 1, Pol e 1	Phospholipase A1	34		0	–
Pol a 2	Hyaluronidase	38		2	–
Pol e 4	Protease	?			
Pol a 5, Pol e 5, Pol f 5, Pol m 5	Antigen 5	23		0	+
<b>FIRE ANTS (<i>Solenopsis invicta</i>, <i>S. geminata</i>, <i>S. richteri</i>, <i>S. saevissima</i>)</b>					
Sol i 1	Phospholipase A1	35	<1	3	–
Sol i 2, Sol g 2, Sol r 2, Sol s 2		14		0	+
Sol i 3, Sol g 3, Sol r 3, Sol s 3	Antigen 5	26		2	+
Sol i 4, Sol g 4		12		0	–

CRR – Carbohydrate-rich protein, DPP IV – dipeptidyl peptidase IV, DW – dry weight, MRJP – major royal jelly protein.

\*Inactive iso form.

The venom of fire ants differs markedly from the other venoms by consisting approximately of 95% water-insoluble alkaloids. The alkaloids produce a sterile pustule. The protein content is only 5%, with a higher content in summer.<sup>15</sup>

Commercial Hymenoptera venom products are available in many countries as lyophilized protein extracts of honeybee, yellow jacket and *Polistes* wasp venoms.

## CROSS-REACTIVITY

A common problem of in vivo and in vitro diagnosis of insect venom allergy using venom extracts is that patients may have double positive test results for honeybee venom (HBV) and yellow jacket venom (YJV).<sup>14</sup> This double positivity may reflect true double sensitization to HBV and YJV, or may be based on IgE cross-reactivity.

Cross-reactivity may be based on IgE reactivity to homologous single venom allergens present in venoms of different families or on IgE reactivity to cross-reactive carbohydrate determinants (CCD).<sup>15</sup> Causative for the latter are IgE antibodies that are directed against an alpha 1,3-linked fucose residue of the *N*-glycan core established by insects and plants. Most HBV and YJV allergens are glycoproteins with one or more such carbohydrate structures (Table 57-2). CCD-specific IgE antibodies have been reported to be responsible for more than 50% of double sensitizations to HBV and YJV.<sup>16</sup> The clinical relevance of CCD-reactive IgE antibodies in the case of insect venom allergy appears to be low or nonexistent.<sup>14,17,18</sup> *Polistes* species seem to lack the alpha 1,3-linked fucose residue that is responsible for IgE reactivity to CCDs.<sup>19</sup>

Recombinant allergens lack CCDs, allowing for a more precise distinction between true double sensitization and cross-reactivity between different venoms.<sup>20</sup> By using CCD-free, correctly folded Ves v 2.0101 and Ves v 2.0201, it could also be demonstrated that hyaluronidases – contrary to previous assumptions – do not play a significant role as major allergens of YJV.<sup>16</sup>

Vespid venoms have been extensively analyzed. Venom allergens of diverse *Vespidae* species such as the white-faced hornet (*Dolichovespula maculata*) or the European hornet (*V. crabro*) are fairly similar to those of the yellow jacket,<sup>21</sup> allowing *V. crabro* allergic patients to be treated with yellow jacket venom.<sup>22</sup>

The IgE cross-reactivity between European and American *Polistes* species is described as low because they belong to different subgenera. In contrast, cross-reactivity between *Polistinae* and *Vespinae* (*Vespula*, *Dolichovespula* and *Vespa*) venoms and purified venom proteins<sup>23</sup> is frequently observed, especially for *Vespula* and both American and European *Polistes* venoms.<sup>24</sup> *Polistes* VIT is not necessary. The converse is also true: half of the people who have had *Polistes* sting reactions have positive skin tests to yellow jacket or hornet venom and require treatment with *Polistes* venom only.

Within the *Apidae* there is cross-reactivity in that people initially sensitized to honeybee venom then react to bumblebee venom due to cross-reactive allergens. Honeybee venom should be effective immunotherapy. Bumblebees have particular importance for pollination industry workers; it has turned out that some of these patients need to be treated with specific bumblebee venom.<sup>10,25</sup>

Little is known of immunologic cross-reactivity between fire ant and vespid venom.

Sol i 1 shares sequences with the venom phospholipases of *Vespula maculifrons*.<sup>26</sup>

## Epidemiology/Etiology

Demographic studies suggest that the incidence of insect sting allergy in the general population ranges between 0.4% and 3%.<sup>1</sup> The majority of reactions that do occur are in younger individuals, although the fatality rate is greater in adults.<sup>9–12</sup> Data on fatal reactions are scarce. It is estimated that 40 to 50 deaths per year occur in the USA as the result of insect sting anaphylaxis<sup>27</sup> and in France 16 to 38.<sup>28</sup> Most of these individuals have had no warning or indication of their allergies and had tolerated earlier stings with no difficulty. Fatal reactions are particularly associated with mastocytosis.<sup>29</sup>

## DEVELOPMENT OF INSECT STING ALLERGY

Hymenoptera stings are frequently encountered in the population. The younger the child, the more often they are (re)stung; in contrast, prevalence of systemic reactions to field stings was significantly lower in preschool (3.4%) and school-age children (4.3%) compared with adolescents (15.6%).<sup>20</sup>

No immunologic criterion, such as skin test reactivity or titers of serum venom-specific IgE or IgG, distinguishes or identifies sting reactors from nonreactors.<sup>30</sup>

The chance of developing an allergy increases with sting frequency.<sup>1</sup> In general, no time relationship exists between the last uneventful sting and the subsequent sting that leads to an allergic reaction<sup>31</sup> although multiple stings or repeated stings in close temporal proximity (only weeks apart) have been associated with a greater risk of developing an allergic reaction.<sup>32</sup> A confusing observation is the occurrence of initial insect sting anaphylaxis after the first known insect sting, primarily in children, raising the issue of the cause of sensitization or the pathogenesis of this initial reaction.<sup>26,33</sup>

## Classification of Reactions

### NORMAL REACTION

The usual reaction to an insect sting consists of localized pain, slight swelling, and erythema at the site of the sting. This reaction usually subsides within several hours. Little treatment is needed other than analgesics and cold compresses.

### LARGE LOCAL REACTIONS

More extensive local reactions are common. Large local reactions are defined as reactions extending from the sting site over a large area, often peaking at 24 to 48 hours and taking 5 to 10 days to resolve. For example, the swelling from a sting on the finger may extend to the wrist or elbow. Fatigue and nausea may develop in addition. For a general clinician it might be difficult to distinguish large local reactions from cellulitis, resulting in misdiagnosis and unnecessary antibiotic treatment.

The cause of these large local reactions has not been established, but it is thought to be an IgE-mediated late-phase reaction.<sup>34</sup>

### TOXIC REACTIONS

Large numbers of simultaneous stings (50–100) may result in a toxic reaction due to the vasoactive properties of the venom. Symptoms can have the same clinical characteristics as



anaphylaxis, including nausea, vomiting, diarrhea, headache, vertigo, syncope, convulsions and fever. Hemolysis, cardiac complications, renal failure and rhabdomyolysis have also been described.<sup>35,36</sup>

As insect venom is highly sensitizing, most patients will develop specific IgE, making the differentiation from an allergic reaction difficult.

### UNUSUAL REACTIONS

There have been rare reports of vasculitis, nephrosis, neuritis, encephalitis and serum sickness occurring in a temporal relationship to insect stings.<sup>37</sup> The symptoms usually start several days to several weeks after the sting and may last for a long period. Serum sickness, characterized by urticaria, joint pain and fever, may occur approximately 7 to 10 days after an insect sting.<sup>22</sup>

Some patients develop cold-induced urticaria days to weeks after Hymenoptera stings, not necessarily accompanied by an allergic reaction to the sting.<sup>38</sup>

#### Systemic Reactions

A systemic allergic reaction consists of signs and symptoms distant from the site of the sting, and may range from mild to life-threatening in one or more anatomic systems. Symptoms usually start within 10 to 15 minutes; the more severe the reaction, the earlier it begins.<sup>39</sup> On occasion, reactions can occur as long as 72 hours later.

The clinical features of anaphylaxis from an insect sting are the same as those of anaphylaxis from any other cause. Diagnosis of the acute reaction can be quite difficult if hypotension or cardiac manifestations occur with no other signs or symptoms.<sup>39</sup>

Studies from children with venom allergy usually report a milder clinical presentation (predominantly isolated cutaneous symptoms) than in adults.<sup>40–42</sup> In a study<sup>43</sup> including more than 500 children, more than 60% suffered only from mild cutaneous reactions. In a more recent study, however, half of the children suffered from respiratory or cardiovascular symptoms.<sup>44</sup>

### Natural History

To assess appropriate intervention, it is necessary to understand the natural history of any disease process. This is particularly true of insect sting allergy. Observations of individuals who have been stung without suffering a reaction, as well as from individuals who had allergic reactions from insect stings and who did not receive VIT, have provided insight into the natural history of this allergy and suggest that insect sting allergy is a self-limiting process for many people, especially children.<sup>45</sup>

### IgE SENSITIZATION

Insect venom is a strong IgE inducer. In the general population, 27.1% to 40.7% have detectable specific IgE (sIgE) to Hymenoptera venoms.<sup>45</sup> In 30% to 50% of these individuals these tests become negative after 2 to 5 years.<sup>46</sup> In a study evaluating the risk to normal adults with positive venom skin tests, there was a 17% incidence of systemic reactions to subsequent stings.<sup>47</sup> In a recent study of asymptomatic patients sensitized to venom who were sting challenged, only 5% experienced

a systemic reaction, whereas >40% had a large local reaction.<sup>30</sup>

Specific IgE for venom, either measured by skin test or serologically, without a history of an allergic reaction therefore does not indicate a risk for venom anaphylaxis.

### NATURAL HISTORY OF LARGE LOCAL REACTIONS

In the past, there was a common misconception that large local reactions after insect stings, particularly those that increased in size with each sting, might precede an anaphylactic reaction. Clinical observations in more recent years indicate that these large local reactions tend to be repetitive.

In children, the risk of anaphylaxis is between 2% and 7%.<sup>45,48</sup> This risk has remained unchanged over a period of 10 to 20 years, and where systemic reactions occurred they were mild to moderate; none was severe.

People who have had large local reactions do not require venom skin tests and they generally are not candidates for VIT, although VIT might be helpful in reducing size and duration of the large local reaction as demonstrated in a placebo-controlled study.<sup>49</sup> In an earlier study the occurrence of subsequent large local reactions was not affected by VIT.<sup>34</sup>

### NATURAL HISTORY OF INSECT STING ANAPHYLAXIS

The majority of children outgrow their allergy, as has been documented in a long-term study of children who were not treated with VIT.<sup>43</sup>

Several factors increase the risk for a repeated systemic reaction. The first is age: the risk for recurrence is higher in adults than in children.<sup>42,43,50</sup> In adults the risk varies between 23.5% and 73%.<sup>31,51–55</sup> The second is the culprit insect: those who are allergic to honeybee venom have a higher risk compared to those with a vespid allergy.<sup>52,54</sup> A third risk factor is the time interval between the stings: there appears to be a gradual decline in the chance of a systemic reaction over time, from almost 50% after a recent reaction to 25% some 7 to 10 years later.<sup>26,31</sup> However, the risk never seems to disappear in some patients having severe reactions to stings, even after decades without an intervening sting.<sup>55</sup> Also, in untreated children, the frequency of systemic allergic reactions declines only slowly over a 20-year period.<sup>43</sup> Even in the same patient the outcome of the next sting may be somewhat unpredictable in that systemic reactions may occur on some occasions and not on others.<sup>56</sup> In a sting challenge study where no reaction occurred at the first sting, a repeated sting caused a systemic reaction in 20% of the patients.<sup>55</sup> It is hypothesized that this variability may be due as much to variation of the allergen during the season,<sup>15</sup> variation in the insect species<sup>57</sup> or the delivery of the allergen<sup>58,59</sup> as to the variations in the patient's physiology or immune status.

### THE SEVERITY OF THE REACTION IS OF PARTICULAR PROGNOSTIC VALUE

Children who have dermal reactions (urticaria, angioedema) only, without other allergic symptoms, are a specific subgroup. These children have a particularly low reaction rate to re-stings, varying from 13%<sup>43</sup> to 18%,<sup>42,50</sup> and when a reaction does occur it tends to be of similar intensity. In adults with dermal

reactions not treated with VIT the risk varies from 9.1% to 33.3% in wasp venom allergic patients and up to 40% in bee venom allergic patients.<sup>54,60–62</sup> In children with more severe reactions (moderate to severe) the risk is about 40%,<sup>31,43</sup> again with generally milder or similar symptoms to those that had occurred previously. Overall, these data suggest that children who only have dermal reactions have a very benign prognosis and generally do not retain their allergic sensitivity.

In contrast to winged Hymenoptera venom allergy, the natural history of imported fire ant venom allergy is not well known. The prevalence of allergic sensitization to imported fire ant (IFA) has been studied in 183 children living in an imported fire ant endemic area.<sup>63</sup> Serum IFA-specific IgE was detected in 7.1% of children aged less than 1 year, 57.1% of those aged 2 to 5 years and 64.4% of those aged 6 to 10 years. Despite this high sensitization rate, the number of anaphylactic reactions to imported fire ant stings was low. These limited data suggest a benign prognosis for children who have had large local or generalized cutaneous reactions only from IFA stings, analogous to experience with winged Hymenoptera.<sup>64</sup>

In an observational study<sup>39</sup> of 657 patients, of which 73% suffered from yellow jacket allergy, four significant indicators and risk factors were identified: elevation of basal serum tryptase (BST), the absence of urticaria or angioedema during anaphylaxis, a time interval of less than 5 minutes from sting to onset of symptoms, and senior age. The absence of urticaria/angioedema was significantly related to BST elevation, suggestive for mastocytosis. In children with preexisting insect venom hypersensitivity, minor increases in BST levels (>5 µg/L) within the normal range are associated with a higher risk of severe systemic reactions.<sup>44</sup>

## Diagnosis and Detection of Venom-Specific IgE

The diagnosis of potential allergy to Hymenoptera venom requires both a history of a sting event that resulted in a systemic allergic reaction and the presence of venom-specific IgE sensitization, assessed either by skin testing or in vitro testing (e.g. IgE immunoassay). Both of these components are necessary to document the diagnosis of insect sting allergy and the possibility of administering VIT.

### HISTORY

As insect stings always cause pain, the history in this regard seems reliable. A comprehensive history should review the patient's past stings and risk for future stings and determine whether the patient's reaction was local or systemic. Relevant questions are listed in [Box 57-1](#).

### VENOM SKIN TESTS

For diagnostic (as well as for therapeutic) purposes, generally refined venom preparations are used because whole body extracts contain little or no venom.<sup>51,56</sup> The exception is fire ant, where skin tests with extracts prepared from whole bodies appear to be reliable.<sup>11,12</sup>

Skin tests can be performed either as prick or intradermal tests. A disadvantage of the skin prick test is its low sensitivity.<sup>30</sup>

### BOX 57-1 RELEVANT QUESTIONS IN ELICITING A HISTORY OF INSECT VENOM REACTIONS

- When did the sting event occur?
- How many stings were sustained?
- Where was the patient when stung? (e.g. On the terrace, in a wood, on vacation in the south, etc.)
- Could the patient identify the insect? (Notoriously unreliable part of the history)
- Where on the body did the sting occur? (As an example, a sting on the face could cause extensive facial angioedema as part of a local reaction, but the same symptoms from a sting on the leg would indicate a systemic response)
- Which symptoms occurred? (Ask about all symptoms, not only the major symptoms)
- Was the patient taking any medication that might have aggravated the reaction? (e.g. β-blockers, ACE inhibitors)
- Were there any previous or subsequent stings? If so, what symptoms developed?
- Is there regular exposure to Hymenoptera insects? (e.g. Bee-keeper, or occupational activities)

Intradermal skin tests are performed starting with venom doses usually around 0.001 µg/mL and testing up to a concentration of 1 µg/mL.<sup>65</sup> Greater venom concentrations may cause irritant reactions that are not immunologically specific. Simultaneous testing of all concentrations of two venoms (bee and wasp) is safe.<sup>66</sup> The skin test should be performed with a fixed amount of allergen (0.02 or 0.03 mL) and also include a negative diluent (human albumin-saline) control and a positive histamine control. A wheal at least half the size of the positive control is considered positive (histamine equivalent wheal size of 3 mm), while others consider a wheal size 3 mm greater than the negative control as positive.

Skin tests are clearly positive in the majority of patients with a convincing history but might be falsely negative if patients are tested too soon after a systemic reaction (attributable to a refractory period of 'anergy'),<sup>67</sup> in patients with mastocytosis<sup>68</sup> or due to lack of particular allergens that are lost or degraded during processing.<sup>58</sup> Generally, guidelines recommend sIgE determination and skin testing no earlier than 2 weeks after the sting because sIgE levels could be decreased or even undetectable.<sup>69</sup> However, there is only weak evidence in the literature for this recommendation.

### IN VITRO MEASUREMENT OF VENOM-SPECIFIC IgE

Venom sIgE can be measured in the serum by in vitro tests, performed by many commercial laboratories with variable assays and variable outcomes. Therefore, especially in the USA, skin tests remain the preferred test for the diagnosis of venom allergy, and are considered to be more sensitive than the in vitro test.<sup>41,70</sup> ImmunoCAP is recognized as a reliable commercial assay and is generally used in Europe.

False-negative results might be partly due to the same problems as in a skin test with loss or degradation of particular allergens during the processing.<sup>58</sup> Of patients with a well-documented history of yellow jacket sting anaphylaxis but negative IgE test results to YJV extract, 84% subsequently were diagnosed using recombinant Ves v 5 as allergen. This discrepancy could be resolved by spiking the venom extract with rVes v 5.<sup>71</sup>

## OTHER DIAGNOSTIC TESTS

### Tryptase

A baseline serum tryptase should be measured to screen for an underlying mast cell disorder, particularly if urticaria/angioedema was absent.<sup>68</sup> Reports about the relevance of mast cell disorders in insect venom allergic children are lacking. BST levels are found to be significantly higher in younger infants compared with older ones, with a gradual decrease to levels similar to those in adults.<sup>72</sup>

Tryptase can also be measured in connection with signs and symptoms of anaphylaxis: an increase from baseline serum tryptase is highly suggestive of IgE-mediated mast cell activation. Concentrations of serum tryptase peak at 60 to 90 minutes after anaphylaxis and decrease to baseline levels over subsequent hours. Total tryptase levels > 11.4 in serum are consistent with systemic anaphylaxis.<sup>73</sup> The tryptase measured immediately after the anaphylactic reaction should preferably be compared with a baseline tryptase sample collected several days after all signs and symptoms have been resolved.

Other mast cell metabolites that can be used either to screen for mastocytosis or to determine anaphylaxis are urinary histamine metabolites.<sup>74,75</sup>

## STING CHALLENGE TESTS

A live sting challenge has been assumed to be the gold standard, especially to evaluate the efficacy of venom immunotherapy. Live sting challenges are mainly performed in research settings. Routine use of a live sting challenge as a diagnostic procedure for selection of patients for immunotherapy has drawbacks, partly ethical<sup>76</sup> but also due to its limited significance because of the lack of reproducibility of one sting.<sup>55,77</sup>

## Therapy

### LARGE LOCAL REACTION

The treatment of large local reactions is symptomatic. There are no studies comparing different treatments. Cold compresses can be used to soothe. Antihistamines can be used to reduce pruritus. Nonsteroidal antiinflammatory drugs can reduce pain and additional flu-like symptoms of nausea and fever. Oral corticosteroids can be used, preferably as quickly as possible after the sting, to reduce significant swelling. They can also be used to prevent large local reactions in individuals with predictable local reactions.

### ACUTE REACTION

The medical treatment for acute anaphylaxis is the same as that for anaphylaxis from any cause and is detailed in Chapter 58.

As venom is deposited very quickly after the sting, prompt removal of the stinger is not able to prevent an allergic reaction. An insect stinger that remains in the skin should be gently flicked off to avoid squeezing the sac, which might inject more venom.

Prior to discharge from the acute care setting, patients should receive a prescription for an EAI, with instructions about how and when to use it, and a referral to an allergist to determine if they are really at risk and need to carry an EAI and whether they are candidates for VIT.

## Prevention of Acute Reactions

The optimal approach in the prevention of any IgE-mediated disease is avoidance of the antigen. Although insect venom allergic patients are able to reduce the frequency of their stings,<sup>36,78,79</sup> this is difficult in practice (e.g. yellow jackets live in close proximity to humans and have unpredictable and pugnacious behavior). Avoidance advice is not evidence based (Box 57-2).

### EPINEPHRINE AUTOINJECTOR

Individuals at risk are advised to carry epinephrine, available in preloaded syringes for self-administration.

Current practice regarding prescribing of EAIs varies widely before, as well as during and/or after stopping VIT,<sup>69,80,81</sup> with some practitioners prescribing them lifelong and also during and/or after stopping VIT. Findings from studies evaluating effects on quality of life suggest the adoption of a more selective approach to prescribing an EAI.

In a randomized study evaluating VIT versus EAI in adults, patients randomized to treatment solely carrying an EAI deteriorated in health-related quality of life,<sup>79</sup> and carrying an EAI was associated with a significant burden.<sup>82</sup> After 1 year of carrying an EAI, almost 80% of the patients preferred to start VIT. The same results were found in dermal reactors,<sup>83</sup> a subgroup of patients who are often prescribed an EAI without being given the option of starting VIT.<sup>69,80</sup> It is not known if the reduced quality of life relates to the prescription of an EAI or actually having to carry one.

The effects of the different treatment options on health-related quality of life have not been studied so far in children with an insect venom allergy. In children with a food allergy it has been shown that carrying an EAI can have a detrimental effect on quality of life, independent of other factors that can also impact quality of life such as whether they have previously suffered anaphylaxis.<sup>84</sup> These studies emphasize that physicians prescribing an EAI should carefully take into account the risks of the disease versus the risks of having an EAI (diminished quality of life) versus benefits (preparedness for treating a potentially life-threatening event).

### VENOM IMMUNOTHERAPY

Therapy with venom is remarkably effective, preventing subsequent allergic reactions in the great majority of treated patients and, in many instances, providing a permanent 'cure'. Whole venom preparations should be used because whole body extracts contain little or no venom.<sup>51,56</sup> However, immunotherapy with whole body fire ant extract appears to be quite effective.<sup>85-87</sup> In

#### BOX 57-2 OPTIONAL PRECAUTIONS TO AVOID SUBSEQUENT STINGS

- Wear slacks, long-sleeved shirts and shoes when outside, especially when involved in activities that might increase insect exposure such as gardening.
- Cosmetics, perfumes and hair sprays might attract insects.
- Light-colored clothing is less likely to attract insects.
- Take care outside around food and garbage, which especially attracts yellow jackets.

jack jumper ant allergy, venom is used and is as effective as honeybee therapy.<sup>88</sup>

Major remaining issues relate to the refining of the selection process for people requiring VIT, choosing the right venom and refining criteria for duration of treatment.

### Indications

Potential candidates for VIT are people who have had an allergic reaction to an insect sting and have a positive venom skin test or elevated levels of serum venom-specific IgE (Table 57-3). As noted, studies of the natural history of insect sting allergy have shown that only approximately 60% or less of these individuals will have a subsequent reaction when re-stung;<sup>31,51</sup> in children the rate is even lower.

Children with only dermal (hives, angioedema) reactions have a very benign prognosis and they do not require immunotherapy.<sup>31,43,50</sup> The risk to both adults and children, including very young children, who have had severe allergic reactions is increased.

Anaphylactic reactions following insect stings can have a great impact on the quality of life of insect sting allergic patients, both adults and children.<sup>79,89</sup> Health-related quality of life is an important therapeutic target in the treatment of allergic patients, as re-sting rates are generally low<sup>22,43</sup> and mortality is surprisingly low, especially in children. In a recent review evaluating the cost-effectiveness of VIT, Hockenull et al<sup>90</sup> concluded that VIT is only cost-effective if it is able to improve health-related quality of life (HRQL), or in the case of a high re-sting rate.

VIT has been shown to improve HRQL in contrast to EAI prescription only.<sup>79</sup> In a randomized study evaluating VIT versus EAI in adults, VIT – with information about the risks and benefits of the treatment – was preferred by most patients and shown to improve health-related quality of life<sup>82</sup> in patients with moderate-to-severe reactions as well as those with only dermal reactions,<sup>83</sup> even if patients are not re-stung. The effect of VIT on health-related quality of life has not been studied so far in children. It is not known what the burden of this

treatment (e.g. receiving injections in addition to frequent visits to the doctor) will be for children.

### Venom Selection

There is general agreement that a positive skin test cannot be used as the sole criterion to start VIT, because at least 25% of the population has specific IgE to one or more venoms without a history of anaphylaxis.<sup>69,80,81</sup> Unnecessary use of additional venoms should be prevented. The administration of a single venom is much better tolerated than the administration of three or four venoms, especially in children, and VIT is a costly treatment.

Knowledge of cross-reactions is necessary to select the correct venom (see Cross-reactivity).

### Dosing Schedule

Treatment is initiated in small doses; the starting dose can be based on the intensity of the skin test reaction and/or the nature of the allergic symptoms. Incremental doses are given until the maintenance dose is reached, traditionally 100 µg. In the USA mixed vespid venom preparations are available for therapy containing the two hornet venoms and yellow jacket venom with a top dose of 300 µg.

There is agreement about the efficacy of 100 µg, originally selected based on the estimated venom protein content of 2 to 4 stings. However, the amount of venom of the different species is different. The amount of honeybee venom is in the range of 50 µg; the amount of vespids is less consistent, ranging from 2 to 20 µg.<sup>91</sup> Patients who are not adequately protected might be protected with higher doses.<sup>92</sup>

A number of dosing regimens are used with different numbers of injections during weekly build-up phases and commonly reaching a maintenance dose in 4 to 6 weeks. VIT can also be given according to a rush desensitization program with multiple doses administered, often in a hospital setting, over a period of 2 or 3 days to 1 week. For some examples of schedules see Table 57-4.

TABLE 57-3

Indications for Venom Immunotherapy in Patients with Positive Venom Skin Tests or Serologically Positive sIgE

Previous Reaction		Skin Test or RAST	Risk of a Systemic Reaction	Advice
No reaction	Children and adults	Unknown	1–3% <sup>1</sup>	None
		Positive	5% <sup>30</sup> to 17% <sup>47</sup>	None
Large local	Children Adults	Not relevant (negative or positive)	2% <sup>43</sup>	None
		Not relevant (negative or positive)	5–10% <sup>13</sup>	None
Systemic reaction – dermal	Children Adults	Positive	1–13% <sup>43</sup>	No VIT, no EAI*
		Positive	9.1–33% (YJ) <sup>60–62</sup> 40% (bee) <sup>54</sup>	EAI* and VIT <sup>183</sup>
Systemic reaction – grade II–IV	Children <5 yr	Positive	>20%/? <sup>43</sup>	EAI* and VIT – controversial due to age
	Children >5 yr	Positive	>32% <sup>43</sup>	EAI* and VIT
	Adults (>15 yr)	Positive	25–70% <sup>31,52–55</sup>	EAI* and VIT
		Negative	?	Further diagnostics: • repeat skin test • sIgE • consider other insects • consider mastocytosis • consider other diagnosis • consider sting challenge

\*The decision to provide an EAI will depend on the practice patterns in each country.

<sup>1</sup>Quality of life is an important target.

RAST – radioallergosorbent test.



**TABLE 57-4** Representative Examples of Venom Immunotherapy Dosing Schedules

	Traditional	Cluster	Modified Rush	Rush
Day				
1	0.1	0.01 0.1 1	0.1 0.3 0.6	0.1 <sup>†</sup> 0.3 0.6 1.0 3.0 6.0 15.0
2				30.0 50.0 <sup>‡</sup> 75.0
3				100.0
Week				
1	0.3		1.0 3.0 6.0	
2	0.6	2.0 4.0	10.0 15.0	100 Repeat every 4 wks
3	1.0	6.0 10.0	30.0	
4	3.0	10.0 20.0	40.0	
5	6.0	30.0 30.0	50.0 <sup>‡</sup>	
6	15.0	50.0 50.0	65.0	
7	30.0	100.0	80.0	
8	50.0 <sup>‡</sup>		100.0	
9	65.0			
10	80.0		100.0	
11	100.0	Repeat every 4–6 wks	Repeat every 4 wks	
12				
13	100.0 Repeat every 4 wks			

\*Starting dose may vary depending on patient's skin test sensitivity. Subsequent doses are modified by local or systemic reactions. Doses expressed in micrograms.

<sup>†</sup>Sequential venom doses administered on the same day at 20- to 30-minute intervals.

<sup>‡</sup>50 µg may be used as the top dose.

Once the top maintenance dose is reached, it can be administered every 4 to 6 weeks.

Preventive medication with antihistamines can be used during VIT, especially during the initial phase. It has been demonstrated to significantly reduce large local and generalized cutaneous reactions in double-blind placebo-controlled trials.<sup>93</sup> This pretreatment affects the expression of histamine receptor and cytokine production of allergen-specific cells. It might also increase the efficacy of VIT,<sup>94</sup> although this could not be proven in the prospective study,<sup>93</sup> probably due to type II error.

### BOX 57-3 APPROACHES IN THE CASE OF SIDE-EFFECTS

#### LARGE LOCAL REACTION

- The venom dose can be split into two injections, limiting the amount delivered at one site.
- Administration of an antihistamine 30–60 minutes before the venom injection.
- Addition of a small amount of epinephrine to the venom may minimize immediate local swelling.
- In the case of extensive delayed-onset swelling, corticosteroids are usually effective, either locally applied or by the addition of a small amount of steroid to the venom.
- In the case of fatigue, successful treatment is usually accomplished with the administration of aspirin approximately 30 minutes before the injection and every 4 hours thereafter for 1–2 days, if needed.

#### SYSTEMIC REACTION

- Dose reduction to 20% with subsequent slow increase.
- Pretreatment with antihistamine 30–60 minutes before the venom injection.
- A few patients require the maintenance dose every 2–3 weeks to avoid a systemic reaction.
- If individuals are receiving multiple venoms, it might be advisable to administer single venoms on separate days.
- Concomitant administration of β-adrenergic blocking drugs can increase the severity of anaphylaxis. ACE inhibitors also have been suggested as potentially exacerbating the severity of allergic reactions.<sup>95</sup>
- Check (again) for mastocytosis.

#### Side-Effects

Reported immunotherapy reaction rates with both rapid and slower schedules vary but are not significantly different. The critical issue is to reach the top maintenance dose.

Local swelling may occur, as may generalized fatigue and aching. Several approaches are available to minimize these reactions (Box 57-3).

Systemic reactions to VIT are unusual and much less common than those induced by pollen immunotherapy. Honeybee venom as compared to vespid venoms is associated with a higher incidence of systemic reactions during the build-up phase. Adverse reactions are no more common in the ultra rush regimen as compared to the modified rush regimen.<sup>96</sup>

There have been no identified adverse reactions caused by long-term VIT. Injections appear to be safe during pregnancy with no effect on the pregnancy or the fetus.

#### Results

VIT is highly effective in preventing subsequent anaphylaxis in children at risk, with comparable efficacy as in adults. In a follow-up study of children, 84.4% of those with anaphylaxis to honeybee and 94.1% to *Vespula* venom were completely protected.<sup>36</sup> In a study by Golden et al in 512 patients the efficacy was 95% in more than dermal reactors, and 100% in dermal reactors; the culprit insects were not mentioned.<sup>43</sup>

Graft et al<sup>97</sup> reported that during a 3- to 6-year period, 200 re-stings in 49 VIT-treated children resulted in only four mild systemic reactions (98% efficacy). Another study of children receiving bee VIT reported five reactors in 55 children after field re-stings.<sup>98</sup>

A recent study by Ruëff et al included more than 1,500 adults receiving a sting challenge 1 year after start of VIT, with a protection rate of 84% for bee VIT and 96% for yellow jacket VIT.<sup>99</sup>

This difference in honeybee versus yellow jacket VIT has been known for decades. Recent studies demonstrated that more than 50% of HBV-allergic patients display IgE reactivity to low-abundance proteins such as Api m 3, Api m 5 and Api m 10.<sup>14,59</sup> Two of these allergens, Api m 3 and Api m 10, are present in the crude venom abstract but absent or under-represented in therapeutic venom preparations.<sup>58</sup> Based on these findings, it is tempting to speculate that the relative lack of these two allergens in therapeutic venom preparations may account for the reduced efficacy of VIT in bee venom-allergic patients, a hypothesis that is currently under investigation.

### Treatment Duration

The question of duration of treatment or when it is safe to discontinue VIT has been a persistent issue. The re-sting reaction rate after cessation of VIT is low, generally in the range of 5% to 15%. The risk of a recurrent systemic reaction to a sting after stopping venom immunotherapy decreases the longer VIT has lasted.<sup>100</sup>

It appears that 3 to 5 years of VIT is adequate for the large majority of individuals who have had mild-to-moderate anaphylactic reactions, despite the persistence of a positive skin test.<sup>60–64</sup> One year of VIT does not provide sufficient protection for nearly 25% of patients.<sup>28</sup> After 3 years of VIT, 83% to 100% of patients are protected against recurrent systemic reactions in

### BOX 57-4 RISK FACTORS FOR INCREASED INEFFICACY OF VIT TREATMENT

Mastocytosis<sup>29,68</sup>

Severe anaphylactic symptoms, such as loss of consciousness, caused by insect sting;<sup>31,101,105</sup> might also be due to mastocytosis

Systemic reactions to venom immunotherapy;<sup>47</sup> might also be due to mastocytosis

Honeybee venom allergy (compared with vespid venom allergy)<sup>101</sup>

Presence of significant medical problems, such as cardiovascular disease

High sting frequency<sup>47,101</sup>

the first 1 to 3 years after stopping, and most of these reactions were only mild.<sup>47,101–107</sup> Studies evaluating more than 5 years of treatment show slightly higher rates of protection.<sup>101,107</sup>

There are several risk factors that are associated with lower efficacy or increased recurrence of systemic reactions (see Box 57-4).

The complete reference list can be found on the companion Expert Consult website at <http://www.expertconsult.inkling.com>.

### KEY REFERENCES

- Reisman RE. Natural history of insect sting allergy: relationship of severity of symptoms of initial sting anaphylaxis to resting reactions. *J Allergy Clin Immunol* 1992;90:335–9.
- Stritzke AI, Eng PA. Age-dependent sting recurrence and outcome in immunotherapy-treated children with anaphylaxis to Hymenoptera venom. *Clin Exp Allergy* 2013;43:950–5.
- Golden DB, Kagey-Sobotka A, Norman PS, Hamilton RG, Lichtenstein LM. Outcomes of allergy to insect stings in children, with and without venom immunotherapy. *N Engl J Med* 2004;351:668–74.
- Yavuz ST, Sahiner UM, Buyuktiryaki B, Soyer OU, Sackesen C, Sekerel BE, et al. Clinical features of children with venom allergy and risk factors for severe systemic reactions. *Int Arch Allergy Immunol* 2013;160:313–21.
- Franken HH, Dubois AE, Minkema HJ, van der Heide S, de Monchy JG. Lack of reproducibility of a single negative sting challenge response in the assessment of anaphylactic risk in patients with suspected yellow jacket hypersensitivity. *J Allergy Clin Immunol* 1994;93:431–6.
- Köhler J, Blank S, Müller S, Bantleon F, Frick M, Huss-Marp J, et al. Component resolution reveals additional major allergens in patients with honeybee venom allergy. *J Allergy Clin Immunol* 2014;133:1383–9.
- Oude Elberink JN, De Monchy JG, Van Der Heide S, Guyatt GH, Dubois AE. Venom immunotherapy improves health-related quality of life in patients allergic to yellow jacket venom. *J Allergy Clin Immunol* 2002;110:174–82.
- Oude Elberink JN, van der Heide S, Guyatt GH, Dubois AE. Analysis of the burden of treatment in patients receiving an EpiPen for yellow jacket anaphylaxis. *J Allergy Clin Immunol* 2006;118:699–704.
- Brown SG, Heddle RJ, Wiese MD, Blackman KE. Efficacy of ant venom immunotherapy and whole body extracts. *J Allergy Clin Immunol* 2005;116:464.
- Golden DB. Long-term outcome after venom immunotherapy. *Curr Opin Allergy Clin Immunol* 2010;10:337–41.

## REFERENCES

- Charpin D, Birnbaum J, Vervloet D. Epidemiology of hymenoptera allergy. *Clin Exp Allergy* 1994;24:1010–15.
- Simons F, Simons R, Peng Z. Mosquito allergy in monograph on insect allergy. In: Levine MI, Lockey RE, editors. *American Academy of Allergy Asthma and Immunology*. Pittsburgh: Dave Lambert Associates; 2003.
- McCormack DR, Salata KF, Hershey JN, Carpenter GB, Engler RJ. Mosquito bite anaphylaxis: immunotherapy with whole body extracts. *Ann Allergy Asthma Immunol* 1995;74:39–44.
- Reiter N, Reiter M, Altrichter S, Becker S, Kristensen T, Broesby-Olsen S, et al. Anaphylaxis caused by mosquito allergy in systemic mastocytosis. *Lancet* 2013;382:1380.
- Hemmer W, Focke M, Vieluf D, Berg-Drewniok B, Götz M, Jarisch R. Anaphylaxis induced by horsefly bites: identification of a 69 kd IgE-binding salivary gland protein from *Chrysops* spp. (Diptera, Tabanidae) by western blot analysis. *J Allergy Clin Immunol* 1998;101(1 Pt 1):134–6.
- Goddard J. *Physician's guide to arthropods of medical importance*. 4th ed. Boca Raton: CRC Press; 2003.
- Vetter RS, Visscher PK, Camazine S. Mass envenomations by honey bees and wasps. *West J Med* 1999;170:223.
- Rudders SA, Clark S, Wei W, Camargo CA Jr. Longitudinal study of 954 patients with stinging insect anaphylaxis. *Ann Allergy Asthma Immunol* 2013;111:199–204.
- McKenna WR. Killer bees: what the allergist should know. *Pediatr Asthma Allergy Immunol* 1992;4:275–85.
- De Groot H. Allergy to bumblebees. *Curr Opin Allergy Clin Immunol* 2006;6:294–7.
- Tan JW, Campbell DE. Insect allergy in children. *J Paediatrics Child Health* 2013;49:E381–7.
- Stafford CT. Hypersensitivity to fire ant venom. *Ann Allergy Asthma Immunol* 1996;77:87–95.
- Kemp SF, deShazo RD, Moffitt JE, Williams DF, Buhner WA 2nd. Expanding habitat of the imported fire ant (*Solenopsis invicta*): a public health concern. *J Allergy Clin Immunol* 2000;105:683–91.
- Spillner E, Blank S, Jakob T. Hymenoptera allergens: from venom to 'venome'. *Front Immunol* 2014;5:77.
- Hannan CJ Jr, Stafford CT, Rhoades RB, Wray BB, Baer H, Anderson MC. Seasonal variation in antigens of the imported fire ant *Solenopsis invicta*. *J Allergy Clin Immunol* 1986;78:331–6.
- Seismann H, Blank S, Braren I, Greunke K, Cifuentes L, Grunwald T, et al. Dissecting cross-reactivity in Hymenoptera venom allergy by circumvention of alpha-1,3-core fucosylation. *Mol Immunol* 2010;47:799–808.
- Hemmer W, Focke M, Kolarich D, Dalik I, Gotz M, Jarisch R. Identification by immunoblot of venom glycoproteins displaying immunoglobulin E-binding N-glycans as cross-reactive allergens in honeybee and yellow jacket venom. *Clin Exp Allergy* 2004;34:460–9.
- Jappe U, Raulf-Heimsoth M, Hoffmann M, Burow G, Hubsch-Muller C, Enk A. In vitro Hymenoptera venom allergy diagnosis: improved by screening for cross-reactive carbohydrate determinants and reciprocal inhibition. *Allergy* 2006;61:1220–9.
- Blank S, Neu C, Hasche D, Bantleon FI, Jakob T, Spillner E. *Polistes* species venom is devoid of carbohydrate-based cross-reactivity and allows interference-free diagnostics. *J Allergy Clin Immunol* 2013;131:1239–42.
- Jakob T, Köhler J, Blank S, Magnusson U, Huss-Marp J, Spillner E, et al. Comparable IgE reactivity to natural and recombinant Api m 1 in cross-reactive carbohydrate determinant-negative patients with bee venom allergy. *J Allergy Clin Immunol* 2012;130:276–8.
- King TP, Joslyn A, Kochoumian L. Antigenic cross-reactivity of venom proteins from hornets, wasps, and yellow jackets. *J Allergy Clin Immunol* 1985;75:621.
- Severino MG, Caruso B, Bonadonna P, Labardi D, Macchia D, Campi P, et al. Cross reactivity between European hornet and yellow jacket venoms. *Eur Ann Allergy Clin Immunol* 2010;42:141–5.
- Monsalve RI, Vega A, Marques L, Miranda A, Fernandez J, Soriano V, et al. Component-resolved diagnosis of vespid venom-allergic individuals: phospholipases and antigen 5s are necessary to identify *Vespula* or *Polistes* sensitization. *Allergy* 2012;67:528–36.
- Caruso B, Bonadonna P, Severino MG, Manfredi M, Dama A, Schiappoli M, et al. Evaluation of the IgE cross-reactions among vespid venoms. A possible approach for the choice of immunotherapy. *Allergy* 2007;62:561–4.
- Hoffman DR, El-Choufani SE, Smith MM, de Groot H. Occupational allergy to bumblebees: allergens of *Bombus terrestris*. *J Allergy Clin Immunol* 2001;108:855–60.
- Hoffman DR, Dove DE, Moffitt JE, Stafford CT. Allergens in Hymenoptera venom. XXI. Cross-reactivity and multiple reactivity between fire ant venom and bee and wasp venoms. *J Allergy Clin Immunol* 1988;82(5 Pt 1):828–34.
- Barnard JH. Studies of 400 Hymenoptera sting deaths in the United States. *J Allergy Clin Immunol* 1973;52:259–64.
- Golden DB, Kwitrovich KA, Kagey-Sobotka A, Lichtenstein LM. Discontinuing venom immunotherapy: extended observations. *J Allergy Clin Immunol* 1998;101:298–305.
- Oude Elberink JN, de Monchy JG, Kors JW, van Doormaal JJ, Dubois AE. Fatal anaphylaxis after a yellow jacket sting, despite venom immunotherapy, in two patients with mastocytosis. *J Allergy Clin Immunol* 1997;99(1 Pt 1):153–4.
- Sturm GJ, Kranzelbinder B, Schuster C, Sturm EM, Bokanovic D, Vollmann J, et al. Sensitization to Hymenoptera venoms is common, but systemic sting reactions are rare. *J Allergy Clin Immunol* 2014;133:1635–43.
- Reisman RE. Natural history of insect sting allergy: relationship of severity of symptoms of initial sting anaphylaxis to resting reactions. *J Allergy Clin Immunol* 1992;90:335–9.
- Pucci S, Antonicelli L, Bilò MB, Garritani MS, Bonifazi F. Shortness of interval between two stings as risk factor for developing Hymenoptera venom allergy. *Allergy* 1994;49:894–6.
- Reisman RE, Osur SL. Allergic reactions following first insect sting exposure. *Ann Allergy* 1987;59:429–32.
- Mauriello PM, Barde SH, Georgitis JW, Reisman RE. Natural history of large local reactions from stinging insects. *J Allergy Clin Immunol* 1984;74:494–8.
- Betten DP, Richardson WH, Tong TC, Clark RF. Massive honey bee envenomation-induced rhabdomyolysis in an adolescent. *Pediatrics* 2006;117:231.
- Stritzke AI, Eng PA. Age-dependent sting recurrence and outcome in immunotherapy-treated children with anaphylaxis to Hymenoptera venom. *Clin Exp Allergy* 2013;43:950–5.
- Light WC, Reisman RE, Shimizu M, Arbesman CE. Unusual reactions following insect stings: clinical features and immunologic analysis. *J Allergy Clin Immunol* 1977;59:391–7.
- Wong CG, Borici-Mazi R. Delayed-onset cold anaphylaxis after hymenoptera sting. *Ann Allergy Asthma Immunol* 2012;109:77.
- Stoevesandt J, Hain J, Kerstan A, Trautmann A. Over- and underestimated parameters in severe Hymenoptera venom-induced anaphylaxis: cardiovascular medication and absence of urticaria/angioedema. *J Allergy Clin Immunol* 2012;130:698–704.
- Lockey RE, Turkeltaub PC, Baird-Warren IA, Olive CA, Olive ES, Peppe BC, et al. The Hymenoptera venom study, I, 1979–82: demographics and history-sting data. *J Allergy Clin Immunol* 1988;82:370–81.
- Chippes BE, Valentine MD, Kagey-Sobotka A, Schuberth KC, Lichtenstein LM. Diagnosis and treatment of anaphylactic reactions to Hymenoptera stings in children. *J Pediatr* 1980;97:177–84.
- Schuberth KC, Lichtenstein LM, Kagey-Sobotka A, Szklo M, Kwitrovich KA, Valentine MD. Epidemiologic study of insect allergy in children. II. Effect of accidental stings in allergic children. *J Pediatr* 1983;102:361–5.
- Golden DB, Kagey-Sobotka A, Norman PS, Hamilton RG, Lichtenstein LM. Outcomes of allergy to insect stings in children, with and without venom immunotherapy. *N Engl J Med* 2004;351:668–74.
- Yavuz ST, Sahiner UM, Buyuktiryaki B, Soyer OU, Sackesen C, Sekerel BE, et al. Clinical features of children with venom allergy and risk factors for severe systemic reactions. *Int Arch Allergy Immunol* 2013;160:313–21.
- Schafer T, Przybylla B. IgE antibodies to Hymenoptera venoms in the serum are common in the general population and are related to indications of atopy. *Allergy* 1996;51:372–7.
- Golden DB, Marsh DG, Freidhoff LR, Kwitrovich KA, Addison B, Kagey-Sobotka A, et al. Natural history of Hymenoptera venom sensitivity in adults. *J Allergy Clin Immunol* 1997;100:760–6.
- Golden DB, Kwitrovich KA, Kagey-Sobotka A, Valentine MD, Lichtenstein LM. Discontinuing venom immunotherapy: outcome after five years. *J Allergy Clin Immunol* 1996;97:579–87.
- Graft DF, Schuberth KC, Kagey-Sobotka A, Kwitrovich KA, Niv Y, Lichtenstein LM et al. A prospective study of the natural history of large local reactions after Hymenoptera stings in children. *J Pediatr* 1984;104:664–8.
- Golden DB, Kelly D, Hamilton RG, Craig TJ. Venom immunotherapy reduces large local reactions to insect stings. *J Allergy Clin Immunol* 2009;123:1371–5.

50. Valentine MD, Schubert KC, Kagey-Sobotka A, Graft DF, Kwitrovich KA, Szkló M, et al. The value of immunotherapy with venom in children with allergy to insect stings. *N Engl J Med* 1990;323:1601–3.
51. Hunt KJ, Valentine MD, Sobotka AK, Benton AW, Amodio FJ, Lichtenstein LM. A controlled trial of immunotherapy in insect hypersensitivity. *N Engl J Med* 1978;299:157–61.
52. Blaauw PJ, Smithuis LO. The evaluation of the common diagnostic methods of hypersensitivity for bee and yellow jacket venom by means of an in-hospital insect sting. *J Allergy Clin Immunol* 1985;75:556–62.
53. Parker JL, Santrach PJ, Dahlberg MJ, Yunginger JW. Evaluation of Hymenoptera-sting sensitivity with deliberate sting challenges: inadequacy of present diagnostic methods. *J Allergy Clin Immunol* 1982;69:200–7.
54. van der Linden PW, Hack CE, Struyvenberg A, van der Zwan JK. Insect-sting challenge in 324 subjects with a previous anaphylactic reaction: current criteria for insect-venom hypersensitivity do not predict the occurrence and the severity of anaphylaxis. *J Allergy Clin Immunol* 1994;94:151–9.
55. Franken HH, Dubois AE, Minkema HJ, van der Heide S, de Monchy JG. Lack of reproducibility of a single negative sting challenge response in the assessment of anaphylactic risk in patients with suspected yellow jacket hypersensitivity. *J Allergy Clin Immunol* 1994;93:431–6.
56. Golden DB, Langois J, Valentine MD, Kagey-Sobotka A, Lichtenstein LM. Treatment failures with whole-body extract therapy of insect sting allergy. *JAMA* 1981;246:2460–3.
57. Golden DB, Breisch NL, Hamilton RG, Guralnick MW, Greene A, Craig TJ, et al. Clinical and entomological factors influence the outcome of sting challenge studies. *J Allergy Clin Immunol* 2006;117:670–5.
58. Blank S, Seismann H, Michel Y, McIntyre M, Cifuentes L, Braren I, et al. Api m 10, a genuine *A. mellifera* venom allergen, is clinically relevant but underrepresented in therapeutic extracts. *Allergy* 2011;66:1322–9.
59. Köhler J, Blank S, Müller S, Bantleon F, Frick M, Huss-Marp J, et al. Component resolution reveals additional major allergens in patients with honeybee venom allergy. *J Allergy Clin Immunol* 2014;133:1383–9.
60. Kampelmacher MJ, van der Zwan JC. Provocation test with a living insect as a diagnostic tool in systemic reactions to bee and wasp venom: a prospective study with emphasis on the clinical aspects. *Clin Allergy* 1987;17:317–27.
61. Engel T, Heinig JH, Weeke ER. Prognosis of patients reacting with urticaria to insect sting. Results of an in-hospital sting challenge. *Allergy* 1988;43:289–93.
62. Golden DB, Breisch NL, Hamilton RG, Guralnick MW, Greene A, Craig TJ, et al. Clinical and entomological factors influence the outcome of sting challenge studies. *J Allergy Clin Immunol* 2006;117:670–5.
63. Partridge ME, Blackwood W, Hamilton RG, Ford J, Young P, Ownby DR. Prevalence of allergic sensitization to imported fire ants in children living in an endemic region of the southeastern United States. *Ann Allergy Asthma Immunol* 2008;100:54–8.
64. Nguyen SA, Napoli DC. Natural history of large local and generalized cutaneous reactions to imported fire ant stings in children. *Ann Allergy Asthma Immunol* 2005;94:387–90.
65. Hunt KJ, Valentine MD, Sobotka AK, Lichtenstein LM. Diagnosis of allergy to stinging insects by skin testing with Hymenoptera venoms. *Ann Intern Med* 1976;85:56–9.
66. Strohmeier B, Aberer W, Bokanovic D, Komeric P, Sturm GJ. Simultaneous intradermal testing with Hymenoptera venoms is safe and more efficient than sequential testing. *Allergy* 2013;68:542–4.
67. Goldberg A, Confino-Cohen R. Timing of venom skin tests and anaphylaxis. *J Allergy Clin Immunol* 1997;100:183.
68. Niedoszytko M, Bonadonna P, Oude Elberink JN, Golden DB. Epidemiology, diagnosis, and treatment of Hymenoptera venom allergy in mastocytosis patients. *Immunol Allergy Clin North Am* 2014;34:365–81.
69. Biló BM, Rueff F, Mosbech H, Bonifazi F, Oude Elberink JN. EAACI Interest Group on Insect Venom Hypersensitivity. Diagnosis of Hymenoptera venom allergy. *Allergy* 2005;60:1339–49.
70. Lantner R, Reisman RE. Clinical and immunologic features and subsequent course of patients with severe insect-sting anaphylaxis. *J Allergy Clin Immunol* 1989;84:900–6.
71. Vos B, Köhler J, Müller S, Stretz E, Ruëff F, Jakob T. Spiking venom with rVesv 5 improves sensitivity of IgE detection in patients with allergy to *Vespula* venom. *J Allergy Clin Immunol* 2013;131:1225–7.
72. Belhocine W, Ibrahim Z, Grandné V, Buffat C, Robert P, Gras D, et al. Total serum tryptase levels are higher in young infants. *Pediatr Allergy Immunol* 2011;22:600–7.
73. Schwartz LB, Metcalfe DD, Miller JS, Earl H, Sullivan T. Tryptase levels as an indicator of mast cell activation in systemic anaphylaxis and mastocytosis. *NEJM* 1987;316:1622–6.
74. van Doormaal JJ, van der Veer E, van Voorst Vader PC, Kluijn PM, Mulder AB, van der Heide S, et al. Tryptase and histamine metabolites as diagnostic indicators of indolent systemic mastocytosis without skin lesions. *Allergy* 2012;67:683–90.
75. Keyzer JJ, de Monchy JG, van Doormaal JJ, van Voorst Vader PC. Improved diagnosis of mastocytosis by measurement of urinary histamine metabolites. *N Engl J Med* 1983;309:1603–5.
76. Reisman RE. Intentional diagnostic insect sting challenges: a medical and ethical issue. *J Allergy Clin Immunol* 1993;91:1100.
77. Hauk P, Friedl K, Kaufmehl K, Urbanek R, Forster J. Subsequent insect stings in children with hypersensitivity to Hymenoptera. *J Pediatr* 1995;126:185–90.
78. Murphy EE, Slavina RG. Decreased incidence of stings in venom-sensitive patients following venom immunotherapy. *Allergy Proc* 1994;15:57–9.
79. Oude Elberink JN, De Monchy JG, Van Der Heide S, Guyatt GH, Dubois AE. Venom immunotherapy improves health-related quality of life in patients allergic to yellow jacket venom. *J Allergy Clin Immunol* 2002;110:174–82.
80. Krishna MT, Ewan PW, Diwakar L, Durham SR, Frew AJ, Leech SC, et al. Diagnosis and management of hymenoptera venom allergy: British Society for Allergy and Clinical Immunology (BSACI) guidelines. *Clin Exp Allergy* 2011;41:1201–20.
81. Moffitt JE, Golden DB, Reisman RE, Lee R, Nicklas R, Freeman T, et al. Stinging insect hypersensitivity: a practice parameter update. *J Allergy Clin Immunol* 2004;114:869–86.
82. Oude Elberink JN, van der Heide S, Guyatt GH, Dubois AE. Analysis of the burden of treatment in patients receiving an EpiPen for yellow jacket anaphylaxis. *J Allergy Clin Immunol* 2006;118:699–704.
83. Oude Elberink JN, van der Heide S, Guyatt GH, Dubois AE. Immunotherapy improves health-related quality of life of adult patients with dermal reactions following yellow jacket stings. *Clin Exp Allergy* 2009;39:883–9.
84. Pinczower GD, Bertalli NA, Busmann N, Hamidon M, Allen KJ, DunnGalvin A, et al. The effect of provision of an adrenaline auto-injector on quality of life in children with food allergy. *J Allergy Clin Immunol* 2013;131:238–40.
85. Freeman TM, Hylander R, Ortiz A, Martin ME. Imported fire ant immunotherapy: effectiveness of whole body extracts. *J Allergy Clin Immunol* 1992;90:210.
86. Tankersley MS, Walker RL, Butler WK, Hagan LL, Napoli DC, Freeman TM. Safety and efficacy of an imported fire ant rush immunotherapy protocol with and without prophylactic treatment. *J Allergy Clin Immunol* 2002;109:556.
87. Judd CA, Parker AL, Meier EA, Tankersley MS. Successful administration of a 1-day imported fire ant rush immunotherapy protocol. *Ann Allergy Asthma Immunol* 2008;101:311.
88. Brown SG, Heddle RJ, Wiese MD, Blackman KE. Efficacy of ant venom immunotherapy and whole body extracts. *J Allergy Clin Immunol* 2005;116:464.
89. Cichocka-Jarosz E, Brzyski P, Swiebocka E, Lange J, Tobiasz-Adamczyk B, Lis G, et al. Health-related quality of life in Polish adolescents with Hymenoptera venom allergy treated with venom immunotherapy. *Arch Med Sci* 2012;8:1076–82.
90. Hockenull J, Elremeli M, Cherry MG, Mahon J, Lai M, Darroch J, et al. A systematic review of the clinical effectiveness and cost-effectiveness of Pharmedin® for the treatment of bee and wasp venom allergy. *Health Technol Assess* 2012;16:III–IV, 1–110.
91. Hoffman DR, Jacobson RS. Allergens in hymenoptera venom XII: how much protein is in a sting? *Ann Allergy* 1984;52:276–8.
92. Ruëff F, Wenderoth A, Przybylla B. Patients still reacting to a sting challenge while receiving conventional Hymenoptera venom immunotherapy are protected by increased venom doses. *J Allergy Clin Immunol* 2001;108:1027–32.
93. Müller UR, Jutel M, Reimers A, Zumkehr J, Huber C, Kriegel C, et al. Clinical and immunologic effects of H1 antihistamine preventative medication during honeybee venom immunotherapy. *J Allergy Clin Immunol* 2008;122:1001–7.
94. Müller U, Hari Y, Berchtold E. Premedication with antihistamines may enhance efficacy of specific-allergen immunotherapy. *J Allergy Clin Immunol* 2001;107:81–6.
95. Ober AI, MacLean JH, Hannaway PJ. Life-threatening anaphylaxis to venom immunotherapy in a patient taking an angiotensin-converting enzyme inhibitor. *J Allergy Clin Immunol* 2003;112:1008–9.
96. Birnbaum J, Charpin D, Vervloet D. Rapid Hymenoptera venom immunotherapy: com-



- parative safety of three protocols. *Clin Exp Allergy* 1993;23:226–30.
97. Graft DF, Schuberth KC, Kagey-Sobotka A, Kwitrovich KA, Niv Y, Lichtenstein LM, et al. Assessment of prolonged venom immunotherapy in children. *J Allergy Clin Immunol* 1987;80:162–9.
  98. Gold SG. A six year review of bee venom immunotherapy in children (abstract). *J Allergy Clin Immunol* 2002;109:S202.
  99. Ruëff F, Vos B, Oude Elberink J, Bender A, Chatelain R, Dugas-Breit S, et al. Predictors of clinical effectiveness of hymenoptera venom immunotherapy. *Clin Exp Allergy* 2014;44:736–46.
  100. Golden DB. Long-term outcome after venom immunotherapy. *Curr Opin Allergy Clin Immunol* 2010;10:337–41.
  101. Lerch E, Muller UR. Long-term protection after stopping venom immunotherapy: results of restings in 200 patients. *J Allergy Clin Immunol* 1998;101:606–12.
  102. Urbanek R, Forster J, Kuhn W, Ziupa J. Discontinuation of bee venom immunotherapy in children and adolescents. *J Pediatr* 1985;107:367.
  103. Müller U, Berchtold E, Helbling A. Honeybee venom allergy: results of a sting challenge 1 year after stopping successful venom immunotherapy in 86 patients. *J Allergy Clin Immunol* 1991;87:702.
  104. Haugaard L, Nørregaard OF, Dahl R. In-hospital sting challenge in insect venom-allergic patients after stopping venom immunotherapy. *J Allergy Clin Immunol* 1991;87:699.
  105. Keating MU, Kagey-Sobotka A, Hamilton RG, Yunginger JW. Clinical and immunologic follow-up of patients who stop venom immunotherapy. *J Allergy Clin Immunol* 1991;88:339.
  106. Golden DB, Addison BI, Gadde J, Kagey-Sobotka A, Valentine MD, Lichtenstein LM. Prospective observations on stopping prolonged venom immunotherapy. *J Allergy Clin Immunol* 1989;84:162.
  107. Ruëff F, Przybilla B, Biló MB, Müller U, Scheipl F, Seitz MJ, et al. Clinical effectiveness of hymenoptera venom immunotherapy: a prospective observational multicenter study of the European academy of allergology and clinical immunology interest group on insect venom hypersensitivity. *PLoS ONE* 2013;8:e63233.

# Anaphylaxis: Assessment and Management

F. ESTELLE R. SIMONS

## KEY POINTS

- Most episodes of anaphylaxis occur in the community, not in healthcare settings. Food is by far the most common trigger. Concomitant asthma increases the risk of severe or fatal anaphylaxis.
- Diagnosis of anaphylaxis is based on recognition of symptoms and signs that occur suddenly (minutes to a few hours) after exposure to a known or likely trigger.
- Prompt treatment of anaphylaxis is essential: call for assistance, inject epinephrine IM in the mid-outer thigh, and place the patient supine or in a position of comfort. Provide oxygen, IV fluids, and other interventions as needed.
- Patients at risk of anaphylaxis should carry one or more epinephrine auto-injectors and a written, personalized, anaphylaxis emergency action plan, and wear medical ID.
- Anaphylaxis triggers should be confirmed and vigilantly avoided. Immunotherapy effectively prevents venom anaphylaxis. Regular follow-up and anaphylaxis education are important aspects of long-term management.

## Introduction

The areas covered in this chapter on anaphylaxis in infants, children and teenagers include: epidemiology, patients at increased risk, mechanisms, triggers, diagnosis, treatment of the acute anaphylactic episode, and long-term management.

Anaphylaxis is defined as a serious generalized allergic or hypersensitivity reaction that is rapid in onset and might cause death. It typically occurs minutes to a few hours after exposure to the trigger and involves two or more body organ systems (Box 58-1). The presence of hypotension or shock is not required in order to make the diagnosis. The term 'anaphylactoid' is no longer recommended for use.<sup>1-4</sup>

## EPIDEMIOLOGY

The rate of occurrence of anaphylaxis is increasing, yet under-diagnosis and under-coding remain a problem. In the general population, the incidence doubled from 21 per 100,000 person years in the 1980s to 49.8 per 100,000 person years in the 1990s, and the highest rate (70 per 100,000 person years) was reported in patients 0.8 to 19 years of age.<sup>6,7</sup>

The hospitalization rate for anaphylaxis in patients under 20 years old increased more than 4-fold between 1990 and 2006, with peaks in the very young (0-4 years) and in teenagers. The

incidence of emergency department (ED) visits and hospitalizations for anaphylaxis increased by 8.8% per year between 1993/4 and 2004/5, with a steep increase in hospitalizations for food-triggered anaphylaxis in children less than 5 years of age. The hospitalization rate for food-induced anaphylaxis more than doubled between 2000 and 2009, from 0.60 to 1.26 per 1,000 total hospitalizations, with corresponding increases in associated healthcare costs.<sup>6-10</sup>

In addition to the increase in ED visits and hospitalizations, critical care unit admissions are also increasing; however, in hospitalized patients, the case fatality rate is low.<sup>11</sup>

Most anaphylaxis fatalities occur in community settings.<sup>12-14</sup> Indeed, most anaphylaxis episodes occur in such settings, where they predominate in boys and in atopic patients. Foods are by far the most common trigger, followed by insect stings and drugs.<sup>15-20</sup>

## PATIENTS AT INCREASED RISK OF SEVERE ANAPHYLAXIS

Severity of concomitant atopic diseases is a predictor of life-threatening anaphylactic episodes. Persistent asthma, especially if not optimally controlled, is an important risk factor for fatal anaphylaxis. Urticaria pigmentosa with extensive (>90%) involvement of the skin or blistering increases the risk of anaphylaxis in infants and children. Concurrent use of antihypertensive medications such as beta-adrenergic blockers and angiotensin-converting enzyme (ACE) inhibitors potentially makes anaphylaxis more severe.<sup>2,21-26</sup> Additionally, infants, teenagers and pregnant teens can be uniquely vulnerable in anaphylactic episodes because of issues with under-recognition and under-treatment.<sup>2,27,28</sup>

Co-factors that can amplify anaphylaxis include exercise, ethanol, NSAIDs (nonsteroidal antiinflammatory drugs), colds or other acute infections, fever, perimenstrual status and emotional stress. Some amplification mechanisms are better understood than others; for example, exercise, ethanol and NSAIDs increase food allergen bioavailability from the gastrointestinal tract, and acute viral infections decrease the mast cell activation threshold.<sup>2,29-31</sup>

## PATHOLOGIC MECHANISMS IN ANAPHYLAXIS

In the pediatric population, anaphylaxis typically involves IgE specific to food, venom or other allergen, high-affinity IgE receptors (FcεR1 receptors), mast cells and basophils and release of mediators of inflammation. These include preformed histamine and tryptase, and newly generated mediators such as platelet-activating factor, leukotrienes, prostaglandins, cytokines and chemokines<sup>2,3</sup> (Figure 58-1).

**BOX 58-1 CLINICAL CRITERIA FOR DIAGNOSIS OF ANAPHYLAXIS**

Anaphylaxis is highly likely when any one of the following three criteria is fulfilled:

1. Acute onset of an illness (minutes to several hours) with involvement of the skin, mucosal tissue, or both (e.g. *generalized hives, pruritus or flushing, swollen lips-tongue-uvula*) **AND AT LEAST ONE OF THE FOLLOWING:**
  - Respiratory compromise (e.g. *dyspnea, wheeze-bronchospasm, stridor, hypoxemia*)\*
  - Reduced BP<sup>†</sup> or associated symptoms of end-organ dysfunction (e.g. *hypotonia [collapse], syncope, incontinence*)
2. Two or more of the following that occur rapidly after exposure to a *likely allergen for that patient* (minutes to several hours):
  - Involvement of the skin-mucosal tissue (e.g. *generalized hives, itch-flush, swollen lips-tongue-uvula*)
  - Respiratory compromise (e.g. *dyspnea, wheeze-bronchospasm, stridor, hypoxemia*)\*
  - Reduced BP<sup>†</sup> or associated symptoms (e.g. *hypotonia [collapse], syncope, incontinence*)
  - Gastrointestinal symptoms (e.g. *crampy abdominal pain, persistent vomiting*)
3. Reduced BP<sup>†</sup> after exposure to a *known allergen for that patient* (minutes to several hours):
  - Infants and children: low systolic BP<sup>†</sup> (age-specific) or greater than 30% decrease in systolic BP<sup>†</sup>
  - Adults: systolic BP<sup>†</sup> or less than 90 mm Hg or greater than 30% decrease from that person's baseline

References: 2,4,5.

BP – Blood pressure.

\*Another example is reduced peak expiratory flow.

<sup>†</sup>Low systolic blood pressure for children is defined as less than 70 mm Hg from 1 month to 1 year, less than (70 mm Hg + [2 × age]) from 1 to 10 years, and less than 90 mm Hg from 11 to 17 years.

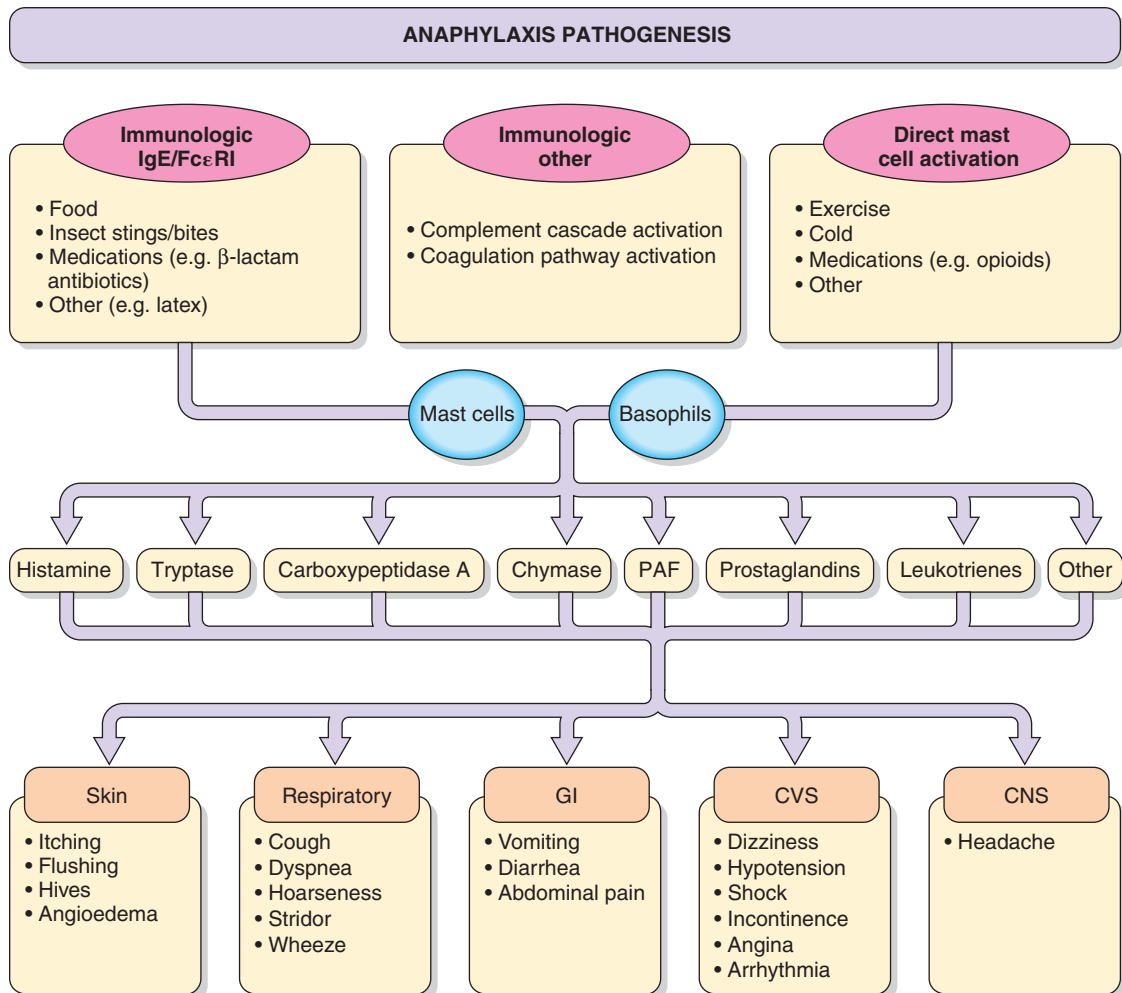

**Figure 58-1** Summary of the pathogenesis of anaphylaxis. Details about mechanisms, triggers, key cells and mediators are found in the text. Two or more target organ systems are typically involved in anaphylaxis. (Adapted from references 1,3.)

Recruitment of other inflammatory pathways has been reported. These include activation of the complement cascade leading to formation of C3a, activation of the coagulation pathway, and activation of the kallikrein-kinin system pathway with kinin formation. Direct activation of mast cells by physical factors such as exercise, exposure to cold water or cold air, or ingestion of medications such as opioids can also trigger anaphylaxis.<sup>1-3,32,33</sup>

IgG-mediated anaphylaxis is reported after administration of high molecular weight dextran or monoclonal antibodies such as infliximab.<sup>1-3,32,34</sup>

## Triggers

In the pediatric population, food is by far the most common trigger of anaphylaxis. Milk, egg, peanut, tree nuts such as cashew, crustacean shellfish such as shrimp, and finned fish are the predominant food triggers in many geographic areas, while sesame, wheat and peach predominate in others. The relative importance of food triggers also differs with age; for example, in infants, milk, egg and peanut are the common concerns<sup>12-20,35-40</sup> (Box 58-2).

Potential food triggers include hidden, substituted, cross-reacting or cross-contacting foods, additives such as spices and colorants, novel food allergens (for example, red

meats containing the carbohydrate allergen galactose- $\alpha$ -1,3,-galactose), contaminants such as storage mites in flour, and food parasites such as the live nematode *Anisakis simplex* in fish. Rarely, anaphylaxis is triggered by skin contact from food as such, vomited food, or inhalation of odors or cooking vapors, e.g. from fish.<sup>1,2,35-37,41-49</sup>

Other anaphylaxis triggers include venom from stinging insects such as bees, yellow jackets, wasps, hornets and ants, and less commonly, saliva from biting insects such as mosquitoes, caterpillars and ticks.<sup>15-20,50-56</sup>

Medication triggers include penicillins, cephalosporins and other antibiotics, NSAIDs such as ibuprofen, and antineoplastic agents. Contaminants in medications, including traces of food, can also trigger anaphylaxis. Peri-operative anaphylaxis can be triggered by antibiotics or by neuromuscular blockers/muscle relaxants such as suxamethonium, but any inhaled, injected or topically applied agent can be implicated, including antiseptics such as chlorhexidine.<sup>15-20,57-65</sup>

Natural rubber latex in medical equipment and supplies can trigger anaphylaxis in healthcare settings, and latex found in some infant pacifiers, bottle nipples, teethers, toys, balloons, sports equipment including balls and racquet handles, and condoms can trigger it in community settings.<sup>2,66</sup>

Other potential triggers include biologic agents such as the monoclonal antibodies infliximab and omalizumab, allergen skin tests (especially intradermal tests), allergen challenge tests, and allergen immunotherapy by any route.<sup>67-69</sup>

Vaccines that protect against infectious diseases seldom trigger anaphylaxis. If they do, the culprit is usually an excipient (such as gelatin, yeast, dextran, polysorbate-80), egg (influenza and yellow fever vaccines), neomycin or polymyxin B, *not* the microbial content.<sup>34,70</sup>

In exercise-induced anaphylaxis, common co-triggers/co-factors include foods (wheat, shrimp, celery), NSAIDs, ethanol, and concurrent exposure to cold water or cold air, which can also trigger anaphylaxis independently of exercise.<sup>30</sup>

Idiopathic anaphylaxis is uncommon in infants, children and teenagers<sup>15-20,71</sup> (see also Idiopathic Anaphylaxis, pages 534 and 535, and Box 58-6).

## Diagnosis

In the pediatric population, diagnosis of anaphylaxis depends almost entirely on the history and physical findings.

## CLINICAL DIAGNOSIS

Diagnosis of anaphylaxis is based on recognition of the sudden onset of characteristic symptoms and signs within minutes to hours after exposure to a known or likely trigger or activity (Figure 58-2). Clinical criteria for diagnosis have been developed and validated as an instrument for rapid assessment of patients who present with a possible diagnosis of anaphylaxis in EDs and other medical settings, or those who present to their primary care physician after the acute event, and for use in epidemiologic studies (Box 58-1). These criteria have high sensitivity for identification of anaphylaxis, good specificity and a high negative predictive value.<sup>4,5,73</sup>

Anaphylaxis is under-reported in the pediatric population,<sup>7</sup> especially in infants.<sup>27,74</sup> First episodes might not be recognized as such, especially if symptoms are mild and/or transient. Skin involvement (itching, flushing, generalized urticaria and/or

### BOX 58-2 ANAPHYLAXIS TRIGGERS

#### ALLERGEN TRIGGERS (IgE-DEPENDENT IMMUNOLOGIC MECHANISMS)

- Foods, e.g. milk, egg, peanut, tree nut, finned fish, crustacean shellfish, soy, and wheat
- Food additives, e.g. spices, colorants, vegetable gums, and contaminants
- Stinging insects: *Hymenoptera* species, e.g. bees, yellow jackets, wasps, hornets and ants
- Medications, e.g. penicillins, cephalosporins and other antibiotics, ibuprofen and other NSAIDs, and chemotherapeutic agents
- Biologic agents, e.g. monoclonal antibodies, and allergens (challenge tests, allergen-specific immunotherapy)
- Natural rubber latex
- Inhalants (rare), e.g. horse dander, and grass pollen
- Uncommon triggers\*
- Novel allergens

#### DIRECT MAST CELL ACTIVATORS

- Physical factors
  - Exercise<sup>†</sup>
  - Cold water or cold air
  - Heat
  - Sunlight/ultraviolet radiation
- Medications, e.g. opioids

#### IDIOPATHIC ANAPHYLAXIS<sup>‡</sup>

Adapted from references 1,2.

NSAIDs – Nonsteroidal antiinflammatory drugs.

\*In the pediatric population, uncommon triggers include vaccines to prevent infectious disease.

<sup>†</sup>With or without co-triggers/co-factors such as foods, ethanol, NSAIDs, cold water or cold air.

<sup>‡</sup>Idiopathic anaphylaxis is uncommon in children. The possibility of a novel trigger or a mast cell activation syndrome should be ruled out.



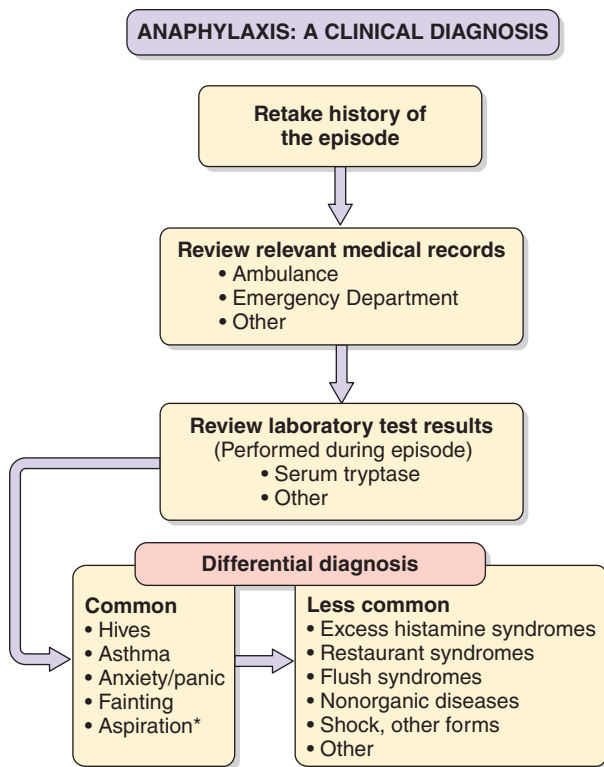

**Figure 58-2** \*of a foreign body. Algorithm for confirming the clinical diagnosis of anaphylaxis. Details about the supreme importance of the history, the role of serum tryptase levels and other laboratory tests, and the differential diagnosis are found in the text and in Box 58-3. (Adapted from references 1–3,36,72.)

angioedema) is helpful in making the diagnosis; however, it is absent or unrecognized in 10% to 20% of anaphylactic episodes and can be missed if itching is absent, if a partial skin examination is performed or if an  $H_1$  antihistamine has been given. Patients with dysphonia, dyspnea or shock might not be able to describe their symptoms. Anaphylaxis might not be recognized as such in an asthmatic with acute respiratory symptoms if concomitant symptoms such as itching, vomiting or dizziness are not reported. Lack of recognition or delayed recognition of anaphylaxis due to patient or caregiver depression or substance abuse might also be relevant.<sup>15–20,27</sup>

In infants, a high index of suspicion is needed in order to diagnose anaphylaxis. They cannot describe their symptoms, and some of their signs can be difficult to interpret because they also occur in healthy babies (Table 58-1). A typical presentation includes skin signs such as generalized urticaria, gastrointestinal signs such as persistent vomiting, and/or respiratory symptoms and signs. Hypotension is often undocumented, for example in settings where infant-size blood pressure cuffs are unavailable.<sup>27,74–76</sup>

## DIFFERENTIAL DIAGNOSIS

The differential diagnosis of anaphylaxis in infants includes age-unique entities<sup>27,74</sup> (Box 58-3). The differential diagnosis of anaphylaxis in children and teens includes common entities such as acute generalized hives associated with viral infection, acute asthma, syncope (faint), anxiety or panic attack, and aspiration of a foreign body. It also includes less

common entities such as excess histamine syndromes (e.g. mast cell activation syndromes, ruptured or leaking hydatid cyst); restaurant (post-prandial) syndromes (e.g. food poisoning, scombroid poisoning); and nonorganic diseases (e.g. vocal cord dysfunction, Munchausen syndrome or Munchausen syndrome by proxy). Flush syndromes are rare in the pediatric population except for nonallergic red man syndrome triggered by vancomycin. Seizures and stroke and other forms of shock (septic, hypovolemic or cardiogenic) should also be considered in the differential diagnosis.<sup>1–3,15–20</sup>

## LABORATORY TESTS TO SUPPORT THE CLINICAL DIAGNOSIS

In the pediatric population, laboratory tests (Figure 58-2) are seldom helpful in confirming the clinical diagnosis of anaphylaxis. The most widely used test, measurement of serum or plasma total tryptase levels,<sup>72</sup> takes several hours to perform and is not available on an emergency basis. Even in blood samples obtained promptly (between 15 minutes and 3 hours) after symptom onset, tryptase levels are seldom elevated in children and in food-induced anaphylaxis. Lack of availability of tryptase measurements is *not* a barrier to prompt clinical diagnosis of anaphylaxis. A tryptase level in the normal reference range *cannot* be used to refute the clinical diagnosis of anaphylaxis. Initial treatment of anaphylaxis should *never* be delayed in order to obtain a blood sample for tryptase measurement.<sup>1–4,72,77–79</sup>

In young infants, interpretation of tryptase levels presents additional complexities, because *baseline* tryptase levels are elevated due to an increased mast cell burden in the developing immune system. At age 3 months, median *baseline* tryptase levels are reported as  $14.2 \pm 10.2 \mu\text{g/L}$  in atopic infants and  $6.1 \pm 3.54 \mu\text{g/L}$  in healthy infants. Levels gradually decline, and by age 9 to 12 months, they reach those found in older infants and young children.<sup>80,81</sup>

Plasma histamine levels and 24-hour urine levels of histamine and its metabolite, *N*-methylhistamine, are measured in some clinical laboratories. Other mast cell mediators such as platelet-activating factor are measured only in research laboratories.<sup>72,77–79</sup>

## Treatment of the Acute Anaphylactic Episode

The essentials of prompt initial anaphylaxis treatment are outlined in Box 58-4. It is important to have a printed protocol that is posted and rehearsed regularly, to have the essential medications, supplies and equipment for emergency treatment readily available, and to pre-designate staff responsibilities. Remove any suspected relevant trigger. Rapidly assess the patient's airway, breathing, circulation, skin and body weight (mass). Simultaneously, call to request help from a resuscitation team in a healthcare setting or from emergency medical services (EMS) in a community setting, inject epinephrine promptly, and place the patient supine or semi-reclining in a position of comfort.<sup>1–4,82,83,91–93</sup>

## EPINEPHRINE (ADRENALINE)

Epinephrine has life-saving  $\alpha_1$ -adrenergic vasoconstrictor effects that prevent and relieve airway obstruction, hypotension

**TABLE 58-1** Symptoms and Signs of Anaphylaxis in Infants

Anaphylaxis Symptoms that Infants Cannot Describe	Anaphylaxis Signs that May be Difficult to Interpret/Unhelpful in Infants, and Why	Anaphylaxis Signs in Infants
<b>GENERAL</b>		
Feeling of warmth, weakness, anxiety, apprehension, impending doom	Behavioral changes such as persistent crying, fussing, clinging, irritability, fright	
<b>SKIN/MUCOUS MEMBRANES</b>		
Itching of lips, tongue, palate, uvula, ears, throat, nose, eyes, etc.; mouth tingling or metallic taste	Flushing (may also occur with fever, hyperthermia or crying spells)	Sudden onset of generalized hives (potentially difficult to discern in infants with acute atopic dermatitis; scratching and excoriations will be absent in young infants); also, angioedema (face, tongue, oropharynx)
<b>RESPIRATORY</b>		
Throat tightness; chest tightness; shortness of breath	Hoarseness, dysphonia (common after a crying spell); drooling/increased secretions (common in teething infants)	Sudden onset of coughing, stridor, wheezing, dyspnea, apnea, cyanosis
<b>GASTROINTESTINAL</b>		
Dysphagia, nausea, abdominal pain/cramping	Drooling, spitting up/regurgitation (common after feeds), loose stools (normal in infants, especially if breastfed); colicky abdominal pain	Sudden onset of persistent vomiting
<b>CARDIOVASCULAR</b>		
Feeling faint or dizzy (pre-syncope), confusion, blurred vision, difficulty in hearing	Hypotension (need appropriate size blood pressure cuff; low systolic blood pressure for infants is defined as less than 70 mm Hg from 1 month to 1 year, and less than (70 mm Hg + [2 × age]) in years in the first and second years of life; tachycardia, defined as greater than 120–130 beats per minute from 3 months to 2 years, inclusive; loss of bowel and bladder control (ubiquitous in infants)	Weak pulse, arrhythmia, diaphoresis/sweating, collapse/unconsciousness
<b>CENTRAL NERVOUS SYSTEM</b>		
Headache	Behavioral changes (see above), drowsiness, somnolence (common in infants after feeding)	Sudden onset of lethargy, hypotonia, unresponsiveness or seizures

Adapted from reference 27.

and shock, and life-saving  $\beta_2$ -adrenergic effects, including bronchodilation and suppression of mediator release from mast cells and basophils<sup>1-4,82-84,94-98</sup> (Box 58-4, Table 58-2).

Epinephrine should be promptly injected intramuscularly in the mid-outer thigh (vastus lateralis muscle) to achieve peak plasma and tissue concentrations rapidly. The epinephrine dose is 0.01 mg/kg IM for first aid treatment (maximum 0.15 mg in an infant; maximum 0.3 mg in a child; maximum 0.5 mg in a teenager). It needs to be injected *before* anaphylaxis progresses to severe respiratory or cardiac symptoms. If indicated, it can be repeated several times at 5–15 minute intervals. Failure to inject it promptly increases the risk of hypoxic-ischemic encephalopathy and death. There is no absolute contraindication to epinephrine treatment<sup>1-4,12-14,82-84,93,94</sup> (Box 58-4).

The severity of an anaphylactic episode can differ from one patient to another, and in the same patient from one episode to another. At the onset, it is impossible to predict whether the patient will respond promptly to treatment, die within minutes or recover spontaneously due to endogenous secretion of epinephrine, angiotensin II and endothelin I.<sup>2</sup>

Rates of epinephrine injection in anaphylaxis are improving in some pediatric emergency departments. In one study

that included prospective data collection, 79% of all pediatric patients with anaphylaxis (and 100% of those with severe anaphylaxis) received epinephrine injections as initial treatment.<sup>95</sup>

Fewer than 20% of pediatric patients with food-induced anaphylaxis treated with epinephrine receive a second dose, either because of failure to respond to the initial dose or because of biphasic anaphylaxis, defined as recurrence of symptoms hours after resolution of the initial symptoms, despite no further exposure to the trigger.<sup>96</sup>

In a retrospective review of ED patients with anaphylaxis, most of whom were children, 17% of those who received one epinephrine injection required one or more additional injections; however, the need for subsequent injections did not correlate with obesity or overweight status. In some patients, the heights and weights used for body mass index calculations were estimated, not measured during the ED visit.<sup>97</sup>

Epinephrine seldom causes serious adverse events in the pediatric population. In patients of all ages, IM epinephrine is 10 times safer than an IV bolus dose of epinephrine. IV injection can be associated with delayed epinephrine administration due to difficult venous access, and with overdose due, for example, to overly rapid infusion or use of a 1:1,000

**BOX 58-3 DIFFERENTIAL DIAGNOSIS OF ANAPHYLAXIS IN INFANTS****SKIN**

Acute episode of urticaria, urticaria pigmentosa/mast cell activation syndrome, hereditary angioedema

**RESPIRATORY (UPPER OR LOWER RESPIRATORY TRACT)**

Acute onset of symptoms due to obstruction, which can be congenital (e.g. laryngeal web, vascular ring, malacias) or acquired (e.g. aspiration of foreign body\*, croup, bronchiolitis, asthma); asphyxiation/suffocation, breath-holding

**GASTROINTESTINAL TRACT**

Acute onset of symptoms due to obstruction, which can be congenital (e.g. pyloric stenosis, malrotation) or acquired (e.g. intussusception), food protein-induced enterocolitis syndrome with an acute presentation

**CARDIOVASCULAR SYSTEM**

Apparent life-threatening event/sudden infant death syndrome; different forms of shock: septic, hypovolemic, cardiogenic, distributive (other than anaphylaxis)

**CENTRAL NERVOUS SYSTEM**

Seizure, postictal state, stroke, trauma, child abuse, increased intracranial pressure

**OTHER, INCLUDING**

- Metabolic disorders
- Infectious diseases: pertussis, gastroenteritis, meningitis
- Ingestion of: drug overdose, poison or toxin (e.g. food, chemical, plant)
- Munchausen syndrome by proxy (Meadow's syndrome)

Adapted from reference 27.

\*Peanuts and tree nuts are commonly associated with both foreign body inhalation and anaphylaxis.

epinephrine solution that has not been appropriately diluted 10-fold or 100-fold.<sup>98</sup> Unless cardiopulmonary arrest is imminent or has occurred, IV epinephrine should be given by physicians skilled in vasopressor administration through an infusion pump with dose titration based on the clinical information obtained by continuous electronic monitoring of blood pressure and cardiac rate and function. Reasons for failure to inject epinephrine promptly and reasons for occasional apparent failure of response to epinephrine injections are listed in **Box 58-5**.<sup>1-4,82-84,95-98</sup>

**OTHER LIFE-SAVING MEASURES**

Supplemental oxygen should be administered by face mask at a flow rate of 8–10 L/minute to patients receiving repeated doses of epinephrine, and those with moderate or severe respiratory symptoms or concomitant asthma.<sup>1-4</sup>

Isotonic (0.9%) saline is preferred for IV fluid resuscitation in anaphylaxis<sup>1-4,36,50</sup> (**Box 58-4**). A Cochrane review of randomized controlled trials (RCT) of IV fluid resuscitation in more than 20,000 critically ill patients (including infants and children) with distributive shock found that administration of colloids such as hetastarch or albumin conferred no survival advantage over crystalloids such as 0.9% saline.<sup>114</sup>

For patients with cardiopulmonary arrest, in addition to rescue breathing at a rate of 15–20 breaths/minute, CPR guidelines now emphasize chest compressions at a rate of at least 100/minute and a depth of 4 cm in infants and 5 cm in children. In teens, they should be performed at a rate of 100–120/minute and a depth of 5–6 cm. Interruptions should be minimized<sup>85</sup> (**Box 58-4**).

**BOX 58-4 TREATMENT OF AN ACUTE ANAPHYLACTIC EPISODE**

- Have a printed, posted emergency protocol for recognition and treatment of anaphylaxis, and rehearse it regularly
- Rapidly assess airway, breathing, circulation, skin and weight (body mass)
- Call for help: emergency medical services (e.g. 9-1-1) in community settings, or resuscitation team in healthcare settings\*
- Inject epinephrine (adrenaline) intramuscularly in the mid-outer thigh in a dose of 0.01 mg/kg (up to a maximum dose of 0.15 mg in an infant, 0.3 mg in a child, or 0.5 mg in a teenager); if there is minimal or no response, it can be repeated several times at 5–15 minute intervals\*†
- Place the patient supine (or in a position of comfort if dyspneic or vomiting) and elevate the lower extremities\*; the patient should not suddenly sit up or stand and should not walk or run
- When indicated:
  - Administer high-flow oxygen (8–10 L/minute) by face mask

- Give nebulized albuterol (salbutamol), 1.25–2.5 mg every 20 minutes or continuously to relieve bronchospasm that persists despite epinephrine injection
- Give IV fluids (child: 0.9% [isotonic] saline, up to 10–20 mL/kg in the first 5–10 minutes<sup>§</sup>; teen: 0.9% [isotonic] saline, 1–2 liters rapidly (5–10 mL/kg in the first 5 minutes)<sup>§</sup>)
- Start cardiopulmonary resuscitation
- Start continuous electronic monitoring of cardiac rate and function, blood pressure, respiratory rate, and monitor oxygen saturation (by pulse oximetry)<sup>||</sup>
- Consider second-line medications<sup>¶</sup>:
  - methylprednisolone IV, 1–2 mg/kg/day (single dose)
  - H<sub>1</sub> antihistamines such as cetirizine by mouth, 0.25 mg/kg to a maximum of 10 mg, or diphenhydramine IV, 1 mg/kg (to a maximum of 50 mg) to relieve itch/hives persisting despite epinephrine injection

Adapted from references 1-4,82-98.

\*Simultaneous steps: call for help, inject epinephrine and position the patient.

†The epinephrine solution for intramuscular injection is 1 mg/mL (1:1,000).

‡Patients with anaphylaxis refractory to intramuscular injection of epinephrine and fluid resuscitation should preferably be transferred to the care of an emergency medicine team with the training, experience and equipment to provide skilled management of the airway and ventilation, and to provide optimal shock management by administering vasopressors safely through an infusion pump, with frequent dose titrations based on continuous electronic monitoring of cardiac rate and function and blood pressure, and monitoring of oxygenation using pulse oximetry.

§Titrate the rate of volume expansion to the cardiac rate and blood pressure; monitor for volume overload; in many pediatric emergency departments, hand-held ultrasound units are now used to monitor for and prevent volume overload.

||If continuous monitoring is not available, monitor vital signs every 1–5 minutes.

¶These second-line medications do not replace epinephrine.

TABLE 58-2

Medications for Anaphylaxis Treatment: Why Epinephrine is the Initial Medication of Choice

Medications	Epinephrine*	$\beta_2$ -Adrenergic Agonist	H <sub>1</sub> Antihistamine†	Glucocorticoid
Pharmacologic effects	At $\alpha_1$ -receptor ↑ vasoconstriction ↑ peripheral vascular resistance ↑ blood pressure ↓ mucosal edema, e.g. in larynx At $\beta_1$ receptor ↑ heart rate ↑ force of cardiac contraction At $\beta_2$ receptor ↓ release of mediators ↑ bronchodilation	At $\beta_2$ receptor ↑ bronchodilation	At H <sub>1</sub> receptor ↓ itch (skin, mucous membranes) ↓ hives and flushing	At glucocorticoid receptor Given to prevent or diminish the late-phase response and biphasic, multiphasic or protracted symptoms associated with ongoing mediator release
Potential adverse effects when given in standard doses	Transient anxiety, pallor, restlessness, tremor, palpitations, headache, dizziness	Tremor, tachycardia, dizziness, jitteriness	First-generation H <sub>1</sub> antihistamines sedate, impair cognitive function, and cause other adverse effects	Adverse effects are unlikely after 1 or 2 doses
Current recommendations	Treatment of first choice	<i>In addition to epinephrine</i> , an inhaled bronchodilator, e.g. albuterol (salbutamol) can be given for bronchospasm	Not life-saving; <i>in addition to epinephrine</i> can be given for relief of itching and hives, if needed; not for initial or sole treatment	Not life-saving; <i>in addition to epinephrine</i> , can be given for the reasons stated above; not for initial or sole treatment

Adapted from references 1–4,82–84,86–90.

\*Epinephrine by IM injection in the mid-outer thigh is the initial treatment of choice in healthcare settings and in community settings.

†Cetirizine 0.25 mg/kg to a maximum of 10 mg by mouth; for intravenous use, diphenhydramine 1 mg/kg, maximum 50 mg.

## SECOND-LINE MEDICATIONS

H<sub>1</sub> antihistamines, H<sub>2</sub> antihistamines, glucocorticoids and  $\beta_2$ -adrenergic agonists are second-line medications in anaphylaxis and should not be substituted for epinephrine in initial treatment or given as the only treatment because they do not prevent or relieve life-threatening laryngeal edema, hypotension or shock<sup>1–4,36,86–90</sup> (Box 58-4, Table 58-2).

In a Cochrane systematic review, no high-quality evidence from RCTs was found to support the use of H<sub>1</sub> antihistamines in the treatment of anaphylaxis. H<sub>1</sub> antihistamines relieve itching, urticaria, flushing and angioedema, but do not relieve life-threatening respiratory or cardiovascular symptoms. Onset of action of an oral liquid formulation of cetirizine takes 30 minutes for relief of itch and 40 minutes for relief of hives. Impairing, nonsedating H<sub>1</sub> antihistamines can interfere with recognition of anaphylaxis symptoms<sup>86–88</sup> (Box 58-4, Table 58-2).

In another systematic review, no high-quality evidence from RCTs was found to support H<sub>2</sub> antihistamine use in anaphylaxis. If given in addition to H<sub>1</sub> antihistamines, they provide slightly increased relief of hives and flushing, but they do not relieve itching or life-threatening respiratory or cardiovascular symptoms.<sup>89</sup>

In other Cochrane systematic reviews, no high-quality evidence from RCTs has been found to support glucocorticoid use in anaphylaxis treatment.<sup>90</sup> These medications do not relieve acute symptoms and signs. Based on limited evidence, they are given to prevent biphasic anaphylaxis symptoms, which are reported to occur in 6% of pediatric patients with anaphylaxis.<sup>115</sup> As their onset of action through transcription of genes encoding pro-inflammatory proteins is relatively slow (hours, not minutes), corticosteroids are good candidates for investigation in RCTs<sup>116</sup> (Box 58-4, Table 58-2).

An inhaled  $\beta_2$ -adrenergic agonist such as albuterol (salbutamol) can be given to patients with wheezing that persists after epinephrine injection<sup>1–4</sup> (Box 58-4, Table 58-2).

## REFRACTORY ANAPHYLAXIS

Patients with anaphylaxis refractory to epinephrine, supplemental oxygen and IV fluids should, if possible, be transferred to the care of a specialist team for ventilatory and inotropic support and continuous electronic monitoring of blood pressure, cardiac rate and function, and respiratory rate and oxygenation (by using pulse oximetry). Where continuous electronic monitoring and pulse oximetry are not available, vital signs should be measured at frequent regular intervals (every 1–5 minutes).<sup>1–4</sup> Based on case reports in adults, methylene blue infusion is life-saving in anaphylaxis refractory to conventional treatment; however, there are no pediatric studies.<sup>117</sup>

## OBSERVATION AND MONITORING

Duration of observation and monitoring in healthcare settings should be individualized; for example, patients with moderate or severe respiratory or cardiovascular symptoms require monitoring for at least 6 to 8 hours. Recommendations for safe observation periods are supported by the finding that mediators measured at intervals during anaphylaxis peak at different times, and some mediators such as histamine, tryptase, IL-6 and IL-10 correlate with delayed deterioration.<sup>77</sup> At discharge, patients should be equipped with an anaphylaxis emergency action plan listing common symptoms, given (or prescribed) an EAI, with information about when, why and how to use it, and instructed to seek follow-up care<sup>1–4</sup> (Box 58-4).

## Long-term Management of Anaphylaxis

Anaphylaxis can lead to impaired quality of life, psychosocial burdens, disrupted activities and anxiety, as assessed by using



**BOX 58-5 EPINEPHRINE IN ANAPHYLAXIS: POINTS TO PONDER****WHY HEALTHCARE PROFESSIONALS FAIL TO INJECT EPINEPHRINE PROMPTLY**

- Lack of recognition of anaphylaxis symptoms/failure to diagnose anaphylaxis
- Episode appears mild, or there is a history of previous mild episode(s)\*
- Inappropriate concern about transient mild pharmacologic effects of epinephrine, e.g. tremor
- Lack of awareness that serious adverse effects are nearly always attributable to epinephrine overdose or to IV administration, especially IV bolus, rapid IV infusion or IV infusion of a 1 : 1,000 epinephrine solution instead of an appropriately diluted solution (1 : 10,000 or 1 : 100,000 concentrations)

**WHY PATIENTS AND CAREGIVERS FAIL TO INJECT EPINEPHRINE PROMPTLY**

- Lack of recognition of anaphylaxis symptoms/failure to diagnose anaphylaxis
- Episode appears mild, or there is a history of previous mild episode(s)\*
- H<sub>1</sub> antihistamine or asthma puffer is used initially instead, relieving early warning signs such as itch and cough, respectively
- Prescription for epinephrine autoinjectors (EAI) not provided by physician
- Prescription for EAI provided but not filled at pharmacy (e.g. if not affordable)
- Patients do not carry EAI consistently (due to size and bulk, or 'don't think they'll need it')
- Patients and caregivers are afraid to use EAI (fear of making an error when giving the injection, or a bad outcome)
- Patients and caregivers are concerned about injury from EAI
- Competence in using EAI is associated with regular allergy clinic visits; it decreases as time elapses from first EAI instruction; regular re-training is needed
- Difficulty in understanding how to use EAI (15% of mothers with no EAI experience could not fire an EAI immediately after a one-on-one demonstration)
- Errors in EAI use can occur despite education, possibly related to the design of some EAI

**WHY PATIENTS OCCASIONALLY FAIL TO RESPOND TO EPINEPHRINE INJECTION**

- Delayed recognition of anaphylaxis symptoms; delayed diagnosis
- Error in diagnosis: problem being treated (e.g. foreign body inhalation) is not anaphylaxis
- Rapid progression of anaphylaxis<sup>†</sup>
- Epinephrine<sup>†</sup>:
  - injected too late, dose too low on mg/kg basis, dose too low because epinephrine solution has degraded (e.g. past the expiration date, stored in a hot place, etc.)
  - injection route or site not optimal; dose took too long to be absorbed
  - patient suddenly sits up or walks or runs, leading to the empty ventricle syndrome
  - concurrent use of certain medications, e.g.  $\beta$ -adrenergic blockers

Adapted from references 2,4,36,82–84,91–113.

\*Subsequent anaphylaxis episodes can be more severe, less severe or similar in severity.

<sup>†</sup>Median times to respiratory or cardiac arrest are 5 minutes in iatrogenic anaphylaxis, 15 minutes in stinging insect venom anaphylaxis, and 30 minutes in food anaphylaxis; however, regardless of the trigger, respiratory or cardiac arrest can occur within 1 minute in anaphylaxis.

validated instruments. The impact is highly variable, ranging from death, disability due to hypoxic-ischemic encephalopathy, severe impact that sometimes necessitates referral to a psychologist or a psychiatrist, minimal impact, or no impact at all if anaphylaxis is unrecognized or undiagnosed, or if the possibility of recurrence is denied or ignored<sup>1,12–14,118–120</sup> (Figure 58-3).

Multiple complexities in anaphylaxis contribute to anxiety. These might include difficulty or lack of confidence in avoiding allergen triggers,<sup>121–123</sup> different allergen thresholds for development of reactions<sup>124</sup> and variation in a patient's personal allergen threshold due to exercise, intercurrent infection, perimenstrual status, emotional stress and other co-factors.<sup>29–31</sup> Patients and caregivers also report anxiety about carrying and using EAI.<sup>125</sup>

Personalized long-term anaphylaxis management aims to achieve a state of minimal impact, in which patients and caregivers are aware of the risk of recurrences but confident that if preventive measures fail, they are prepared to recognize and manage an anaphylactic episode.<sup>1</sup>

Long-term risk reduction measures include emergency preparedness to treat anaphylaxis in community settings, follow-up with a physician, preferably an allergy/immunology specialist, as well as contact with parent/patient support groups.<sup>99–113,126</sup> Additional important measures include investigations to confirm the triggers,<sup>36,50,127–132</sup> prevention of recurrences through avoidance and, where relevant, immune modulation,<sup>36,50,51,125,133–143</sup> and optimal management of asthma and other co-morbidities<sup>1–3</sup> (Box 58-6, Figure 58-4).

**EMERGENCY PREPAREDNESS TO TREAT ANAPHYLAXIS IN COMMUNITY SETTINGS**

Anaphylactic episodes can occur despite vigilant efforts to avoid known confirmed triggers.<sup>121–123</sup>

**Self-Injectable Epinephrine**

Those at risk for anaphylaxis in the community and/or their caregivers, should be taught how to recognize anaphylaxis and inject epinephrine correctly and safely using an EAI (Table 58-2, Box 58-5). Only two pre-measured fixed doses of epinephrine, 0.15 mg and 0.3 mg, in autoinjector formulations are available in the USA and Canada. The 0.15 mg dose is high for infants weighing 10 kg or less and for some young children. The 0.3 mg dose might be low for some overweight or obese children and adolescents. Written instructions should be provided along with a website link demonstrating the correct EAI technique. EAI are not available in many countries. Patients at risk of anaphylaxis who travel abroad should therefore carry more than two EAI.<sup>1–4,99</sup>

Currently available alternatives to EAI are not recommended. These include use (by a non-healthcare professional) of a 1 mL syringe to draw up and measure an epinephrine dose from an ampule (problems: delay in drawing up the epinephrine and inaccurate dosing) and use of an unsealed syringe prefilled with the epinephrine dose (problem: loss of dose within 3 or 4 months due to air exposure and rapid epinephrine solution degradation).<sup>83,100,101</sup>

Deaths from anaphylaxis typically occur in community settings,<sup>12–14</sup> yet some physicians fail to prescribe EAI for their patients at risk of anaphylaxis recurrences in the community. Moreover, many patients do not carry their EAI consistently or use them when anaphylaxis occurs, even for severe symptoms including throat tightness, difficulty breathing, wheezing and loss of consciousness.<sup>102,103</sup> Many mothers cannot 'fire' an EAI

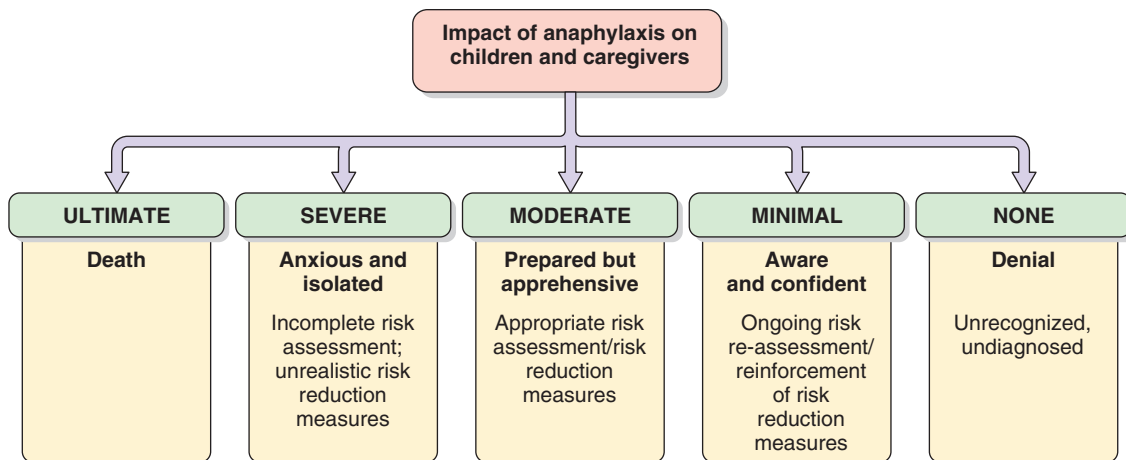

**Figure 58-3** The impact of anaphylaxis on infants, children, teens and their caregivers and families ranges from the ultimate impact, death, to no impact at all. Long-term risk reduction measures include emergency preparedness to treat anaphylaxis recurrences in community settings, confirmation of the triggers and prevention of recurrences through avoidance and, where relevant, immune modulation. Other measures, including optimal management of co-morbidities such as asthma and contact with parent/patient support groups, are also important in minimizing the impact of anaphylaxis on pediatric patients, their caregivers and families. (Adapted from references 1,118–120.)

### BOX 58-6 STRATEGIES TO PREVENT ANAPHYLAXIS IN COMMUNITY SETTINGS

#### AVOID SPECIFIC ALLERGEN TRIGGERS\*

Foods, including hidden or cross-reacting foods and food additives, e.g. spices, colorants, vegetable gums, contaminants  
 Insect stings and bites  
 Drugs  
 Biologic agents  
 Natural rubber latex  
 Novel allergens<sup>†</sup>

#### AVOID DIRECT MAST CELL TRIGGERS, IF RELEVANT

Exercise: do not avoid exertion, but avoid co-triggers and co-factors<sup>‡</sup>  
 Cold air, cold water  
 Heat  
 Sunlight/ultraviolet radiation  
 Medications, e.g. opioids

#### IMMUNE MODULATION, IF RELEVANT

Foods: natural desensitization to milk and egg often occurs and can be facilitated; see text for details  
 OIT and SLIT to milk, egg and peanut: research settings only (see text for details)  
 Insect venoms: subcutaneous allergen immunotherapy  
 Medications, e.g. penicillins and other antibiotics: desensitization

#### PHARMACOLOGIC PROPHYLAXIS, IF RELEVANT

Idiopathic anaphylaxis: favorable natural history. Prophylaxis with a glucocorticoid, e.g. prednisone, an H<sub>1</sub> antihistamine, e.g. cetirizine, and, if indicated, omalizumab can be given

Adapted from references 35–37,50–63,70,133–143.

NSAIDs – Nonsteroidal antiinflammatory drugs; OIT – oral immunotherapy; RCT – randomized controlled trials; SLIT – sublingual immunotherapy.

\*Suggested by the history and confirmed by skin tests and allergen-specific IgE levels.

<sup>†</sup>Save the allergen, e.g. food or insect for identification, and save the patient's serum for allergen-specific IgE measurements.

<sup>‡</sup>Avoid relevant co-triggers such as foods, cold air and cold water, and avoid relevant co-factors such as NSAIDs.

### Long-Term Risk Reduction (Community Settings)

#### Assess/treat co-morbidities

- Asthma
- Mast cell activation disorder
- Cardiovascular disease
- Other

#### Assess need for co-medications

- $\beta$ -blockers, ACE inhibitors
- Other

#### Allergen avoidance information

- [www.foodallergy.org](http://www.foodallergy.org)
- [www.latexallergyresources.org](http://www.latexallergyresources.org)
- [www.aaaai.org](http://www.aaaai.org)
- [www.acaai.org](http://www.acaai.org)

#### Immunomodulation

- **Allergen specific**
  - Immunotherapy with insect venom
  - Desensitization to medication, e.g.  $\beta$ -lactam antibiotics, other
- **Allergen nonspecific**
  - Idiopathic anaphylaxis: consider prophylaxis

#### Emergency preparedness

- Epinephrine autoinjector
- Anaphylaxis emergency action plan ([www.aaaai.org](http://www.aaaai.org))
- Medical ID

**Figure 58-4** Summary of the approach to long-term management. Optimal management of co-morbidities such as asthma decreases the risk of severe or fatal anaphylaxis. Avoidance measures are allergen specific. Immune modulation is currently used to prevent anaphylaxis recurrences from insect stings and from some medications. Emergency preparedness measures, including epinephrine autoinjectors, written, personalized, anaphylaxis emergency action plans and medical ID are critically important. ID – Medical identification (e.g. bracelet, wallet card). (Adapted from references 1–3,126,144.)

trainer correctly when tested immediately after one-on-one instruction.<sup>104</sup> Many parents fear using EAI due to the possibility of hurting or injuring their child, or a bad outcome.<sup>105,121</sup> Thousands of unintentional injections and injuries to digits and other body parts have been reported with pen-type EAI.<sup>106</sup> Training to use EAI increases accuracy and speed; however, these skills are lost within a few months.<sup>107,108</sup> For all these reasons, anaphylaxis recognition and EAI technique should be reviewed at frequent regular intervals<sup>102–108,121</sup> (Box 58-5).

A novel, user-friendly EAI introduced in the USA and Canada in 2013 was designed with input from children, teens, and adult caregivers. It is compact, robust and intuitive to use correctly. It has audio and visual prompt systems that tell the user what to do and signal when injection is complete. It also protects from unintentional injections before and after use because the safety guard and needle guard are on the same end of the device; additionally, the needle is fully retractable.<sup>109,110</sup>

Pediatric allergists were surveyed about when they typically began to transfer responsibilities for anaphylaxis recognition and EAI use from adult caregivers to children and teenagers at increased risk of anaphylaxis in community settings. They expected that by age 12 to 14 years, their patients should begin to share these responsibilities. They started to train early and individualized the time of transfer based on patient factors such as presence of asthma and absence of cognitive dysfunction. However, caregivers of at-risk children and teenagers expected to begin transfer of responsibilities considerably earlier, when children are age 6 to 11 years.<sup>111,112</sup>

### Anaphylaxis Emergency Action Plan

Epinephrine autoinjectors should be prescribed in the context of a written, personalized, anaphylaxis emergency action plan; for examples, see [www.aaaai.org](http://www.aaaai.org), [www.aaaai.org](http://www.aaaai.org) or [www.anaphylaxis.ca](http://www.anaphylaxis.ca). Such plans typically list common symptoms and signs of anaphylaxis, and list the steps for initial anaphylaxis treatment: call 9-1-1 or EMS, inject epinephrine promptly from an EAI and avoid sitting up, standing, walking or running. Plans should include reminders that H<sub>1</sub> antihistamines and asthma puffers should not be used as initial treatment or as the only treatment. As documented in an RCT, healthcare professionals' knowledge about recognition and treatment of anaphylaxis improved significantly after brief study of a wallet card-size plan.<sup>1,2,4,36,113,126</sup>

### Medical Identification

Patients at risk for anaphylaxis recurrences should wear medical identification listing their confirmed trigger(s) and their relevant co-morbidities such as asthma. Options include medical identification jewelry, eg. Medic-Alert (Turlock, CA, [www.medicalert.org](http://www.medicalert.org)), cards (available at [www.aaaai.org](http://www.aaaai.org)) for carrying in a wallet, purse or backpack, and T-shirts or cloth badges imprinted with allergy alert messages for infants and young children. Medical identification needs to be updated regularly.<sup>1,2,36,126</sup>

## INVESTIGATIONS TO CONFIRM THE TRIGGER(S)

Patients with a history of an anaphylactic episode benefit from assessment by a trained and certified allergy/immunology specialist who takes the time required to obtain a meticulous history of the event as the basis for selection of allergens for skin tests and specific IgE levels in serum, and for interpretation of test results<sup>2,35–37,50,57–62,127–129</sup> (Figure 58-5).

## ANAPHYLAXIS: CONFIRM THE TRIGGER

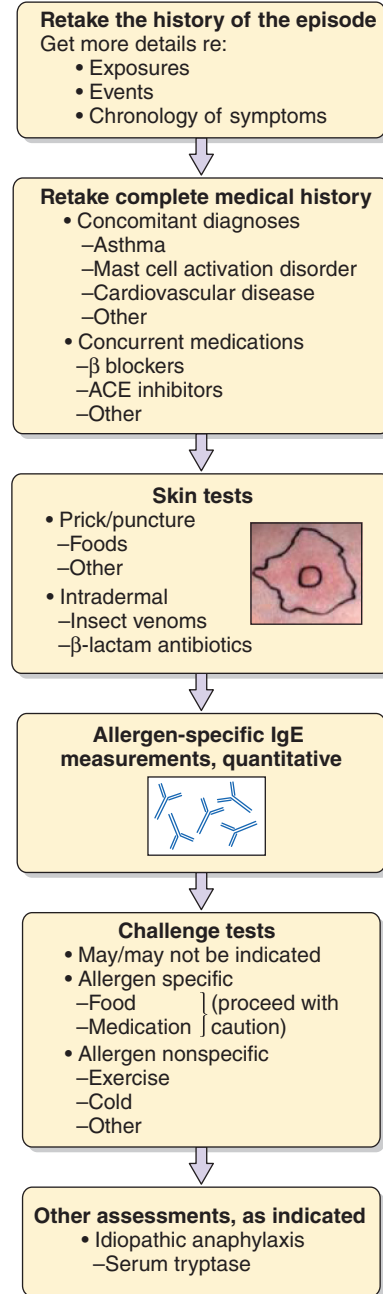

**Figure 58-5** Algorithm for confirming anaphylaxis triggers. The importance of the history, and information about skin tests and specific IgE measurements to determine allergen sensitization are described in detail in the text. In selected patients, physician-monitored challenge tests are needed to determine the clinical relevance of sensitization. (Adapted from references 1,2,35–37,50,57–62,127–132.)

Skin prick tests are performed to assess sensitization to foods, stinging insect venoms, medications, natural rubber latex and other allergens. Fresh foods, for example fresh fruits and vegetables, can be tested using the prick-prick technique. Intradermal tests are contraindicated in the work-up for food-induced anaphylaxis;<sup>35–37,127–129</sup> however, they are useful in the work-up for venom-induced anaphylaxis<sup>50</sup> and drug-induced anaphylaxis.<sup>57–62</sup>

Allergen-specific IgE levels are typically measured using the ImmunoCap assay (ThermoFisher Scientific, Waltham, MA). Reference ranges developed for milk-, egg-, peanut-, tree nut- and fish-specific IgE levels are based on this immunoassay and are not necessarily interchangeable with those based on other immunoassays.<sup>35</sup>

Positive allergen skin tests and/or increased allergen-specific IgE levels confirm sensitization to the allergens tested. They are not diagnostic of anaphylaxis because allergen sensitization without food-induced anaphylaxis is extremely common in the general pediatric population and in patients with atopic dermatitis. Although children with positive allergen skin tests and positive allergen-specific IgE levels have an increased probability of clinical reactivity to the allergens tested, the level of positivity of these tests does not necessarily predict the severity of future anaphylactic episodes.<sup>35–37,127–129</sup>

Physician-monitored incremental food challenge (provocation) tests are sometimes needed to determine the clinical relevance of borderline positive allergen skin tests or absent or low-positive allergen-specific IgE levels in patients who have an equivocal history of anaphylaxis. Food challenge tests should be conducted in well-equipped healthcare facilities staffed by professionals trained and experienced in patient selection, performing and interpreting these tests and recognizing and treating anaphylaxis. A positive (failed) challenge provides a sound basis for continued avoidance of the food. A negative (passed) challenge allows introduction or re-introduction of the food into the diet. Food challenge tests have recently been standardized. The caveat ‘First, do no harm’ applies. Patients with a convincing history of a food-induced reaction and evidence of sensitization to that food should *not* undergo oral food challenge tests because of their risk of anaphylaxis.<sup>35–37,130</sup>

The need for potentially risky challenge tests can be reduced by use of allergen component tests that differentiate clinical reactivity associated with IgE binding to potent stable allergens such as casein in milk, ovomucoid (Gal d 1) in egg, or Ara h 2 in peanut from less clinically relevant sensitization (allergens binding to heat-labile proteins).<sup>131,132</sup>

Physician-supervised challenge tests are contraindicated in patients with venom-induced anaphylaxis, unless performed in the context of an RCT.<sup>50</sup> Challenges are indicated in selected patients with a history of drug-induced anaphylaxis.<sup>57–62</sup>

Before making the diagnosis of idiopathic anaphylaxis, physicians should rule out a hidden or novel anaphylaxis trigger, perform a meticulous examination of the skin and obtain a baseline serum tryptase level to rule out a mast cell activation syndrome.<sup>71</sup>

## AVOIDANCE OF TRIGGER(S)

Printed personalized information about avoidance of specific trigger(s) should be provided and reviewed at regular intervals (Box 58-6).

### Foods

Complete avoidance of exposure to some foods such as milk, egg or peanut is easier said than done and is easier done than maintained over years or decades. Unintentional exposures are common. The constant vigilance required every day in order to avoid hidden, cross-contacting and cross-reacting food triggers can negatively affect quality of life of patients, caregivers and family members. Bullying of food-allergic

children and teens is widespread and often occurs without parental awareness.<sup>35–37,41,42,118–120</sup>

Reliable resources for accurate, practical information are maintained and updated by Food Allergy Research & Education (FARE) ([www.foodallergy.org](http://www.foodallergy.org)) and by Anaphylaxis Canada ([www.anaphylaxis.ca](http://www.anaphylaxis.ca)). For patients with multiple dietary restrictions, a licensed nutritionist can provide helpful information about essential nutrients, basic food groups and safe substitutes.<sup>35–37</sup>

### Stinging Insects

Avoidance of exposure involves professional extermination of yellow jacket or wasp nests or fire ant mounds around the patient’s home, and having the patient avoid uncovered sources of food and beverages at barbecues, picnics and campgrounds and wear protective clothing including shoes and socks when outdoors. Personal insect repellents such as DEET are not effective in preventing *Hymenoptera* stings, although they prevent insect bites.<sup>50</sup> Children less than 6 years old are more likely to be stung than older children but systemic allergic reactions increase with age.<sup>52</sup>

### Drugs and Biologic Agents

Culprit drugs or agents should be avoided. An alternative non-cross-reacting agent should be substituted, preferably from a different therapeutic class but sometimes from the same class (for example, a third-generation cephalosporin for a first-generation cephalosporin).<sup>57–62</sup>

### Exercise

Patients with exercise-induced anaphylaxis should not avoid exertion; however, they should avoid their relevant co-triggers/co-factors (foods, ethanol, NSAIDs, cold water or cold air, and high pollen counts). If none can be identified, they should have a trial of fasting for 4 to 6 hours before exertion. Also, they should never exercise alone, and if any symptom develops, they should stop exercise immediately and avoid running for help. They should carry one or more EAs and, if relevant (e.g. during skiing), carry a cell phone for dialing 9-1-1/EMS.<sup>1,4,30</sup>

## IMMUNE MODULATION

Immune modulation is currently recommended for prevention of anaphylaxis triggered by insect venoms and some drugs. It is not yet recommended for prevention of food-induced anaphylaxis, except in the context of an RCT<sup>50,57–63,137–142</sup> (Box 58-6, Figure 58-4).

### Food-Induced Anaphylaxis

Natural desensitization occurs in many infants and children with clinical reactivity to food such as milk or egg, especially in those with relatively low allergen-specific IgE levels, small prick test wheal sizes and mild initial reactions. A history of tolerating small amounts of unintentionally ingested extensively heated (baked) milk or egg is a marker of transient IgE-mediated allergy. Addition of baked milk or egg to the diet of these patients accelerates the development of tolerance to unheated milk or egg during childhood and adolescence. In contrast, ongoing reactivity to small amounts of baked milk or egg suggests a more severe phenotype and the need to continue strict dietary avoidance.<sup>135–136</sup>

RCTs of oral immunotherapy (OIT) or sublingual immunotherapy (SLIT) of foods such as milk, egg or peanut can lead to



clinical tolerance (desensitization). Immunologic tolerance is more elusive. Adverse effects are common. Food OIT should be undertaken only in well-equipped centers by physicians who are specifically trained and experienced in administering OIT and in diagnosing and treating anaphylaxis. Adverse effects during food OIT can potentially be reduced by pretreatment and co-treatment with omalizumab. SLIT to prevent food-induced anaphylaxis causes fewer adverse effects than OIT but is less effective.<sup>137–140</sup>

### *Insect Sting-Induced Anaphylaxis*

Anaphylaxis from bee, yellow jacket, wasp and hornet venom(s) can be prevented in 97% to 98% of children and teenagers with a history of systemic reactions treated with a 3- to 4-year course of subcutaneous injections of the relevant standardized stinging insect venom(s). The protective effect can last 10 to 20 years after venom injections are discontinued. For prevention of anaphylaxis from fire ant stings, subcutaneous injections with whole body fire ant extract are indicated.<sup>50–52,54,93,141</sup>

### *Drug-Induced Anaphylaxis*

For prevention of anaphylaxis recurrence from a drug such as an antibiotic, an NSAID, a chemotherapeutic agent, or a monoclonal antibody, when no safe substitute is available, desensitization can be conducted by an experienced allergy/immunology specialist using incremental doses and a published protocol. This technique is safe and effective for one uninterrupted course of treatment; however, long-lasting immunologic tolerance is not achieved and symptoms typically recur when the drug or biologic agent is restarted after being discontinued.<sup>57–63,142</sup>

### *Idiopathic Anaphylaxis*

The natural history of idiopathic anaphylaxis is favorable. In the absence of RCTs of pharmacologic prophylaxis, management recommendations are based on expert opinion. If episodes are frequent ( $\geq 6$  per year, or  $\geq 2$  per 2 months), prophylaxis with an oral glucocorticoid such as prednisone and a nonimpairing, nonsedating H<sub>1</sub> antihistamine such as cetirizine should be considered. Omalizumab can be helpful in patients refractory to conventional treatment.<sup>71</sup>

### *Pharmacologic Prophylaxis of Anaphylaxis*

There are few RCTs of pharmacologic prophylaxis; however, one RCT has confirmed that epinephrine pretreatment reduces anaphylaxis to anti-snake venom by 43% and is more effective prophylaxis than H<sub>1</sub> antihistamine and/or glucocorticoid pretreatment.<sup>143</sup>

## **PREVENTION OF ANAPHYLAXIS IN SPECIFIC SETTINGS**

Unique aspects of anaphylaxis prevention in the physician's office or clinic setting and in school settings will be reviewed briefly.

### *Physician's Office or Clinic*

Anaphylaxis in this setting, although probably inevitable, is not a random event. It can be triggered by a food or drug challenge test, infusion of a biologic agent, subcutaneous allergen-specific immunotherapy and, rarely, by allergen skin tests or vaccinations to prevent infectious diseases. In this setting, the allergen and time of exposure are known and the healthcare professionals involved are likely aware of the patient's co-morbidities, concurrent medications and body mass (weight).<sup>1</sup>

Prevention of anaphylaxis in an office or clinic setting involves awareness of procedure-related risk factors and patient-related risk factors, careful selection of patients for diagnostic and therapeutic interventions, reassessment of patients before each intervention and deferral of interventions when clinically indicated, for example in a patient with an asthma exacerbation or an FEV<sub>1</sub> of  $\leq 70\%$  predicted.<sup>1</sup>

Specific wait times after diagnostic and therapeutic interventions are suggested to ensure patient safety; for example, 30 minutes after allergen immunotherapy, one hour after completion of a food challenge and 30 minutes to 2 hours after omalizumab injections for asthma. As patients and caregivers can be inconvenienced by waiting, and sometimes try to leave early, an EAI should be prescribed and they should be trained to recognize anaphylaxis symptoms and use the EAI promptly if symptoms occur after they leave the office or clinic.<sup>50,67,68</sup>

### *Anaphylaxis in Schools and Other Community Settings*

Twenty percent of children experience their first anaphylaxis episode at school. The first episode can be fatal. Increased availability of stock (unassigned) EAI that are not prescribed for a specific child but available for use in any child with anaphylaxis is anticipated to reduce morbidity and mortality in this setting. Prevention of anaphylaxis recurrences in schools, and preparedness to recognize and treat it, involves the student, the family, the student's physician and the school.<sup>145–148</sup> (Box 58-7).

In community settings, broader training in prompt recognition and treatment of anaphylaxis is needed not only for teachers and all other school personnel, but also for coaches, camp directors, childcare providers, restaurant and food industry workers, airline personnel and the public. The goal of training is to increase awareness that anaphylaxis is not a trivial lifestyle problem but rather a killer allergy that needs to be recognized and treated promptly. Increased availability of stock EAI in public places such as shopping malls and sports facilities will contribute to decreased morbidity and mortality from anaphylaxis in community settings.<sup>1,2,144–150</sup>

Anaphylaxis education for everyone involved with infants, children and teens should emphasize the sudden onset and potentially rapid progression to multisystem involvement and life-threatening symptoms during an anaphylactic episode, the need to be prepared, to recognize and treat it promptly, and to understand the critical role of allergen avoidance in prevention of anaphylaxis recurrences.<sup>1,2,144–150</sup>

## **Conclusions**

The rate of occurrence of anaphylaxis is increasing in the pediatric population. The pathologic mechanism typically involves allergen-specific IgE and high-affinity IgE receptors (FcεR1 receptors) on mast cells and basophils. Food is by far the most common trigger; however, any trigger is possible. Some patients, for example those with severe or uncontrolled asthma, are at increased risk for severe and fatal anaphylaxis.

Diagnosis of anaphylaxis is based on recognition of sudden onset of characteristic symptoms and signs within minutes to a few hours after exposure to a known or likely trigger or activity. Validated clinical criteria for diagnosis are available for use. Prompt recognition and initial treatment of an acute anaphylactic episode are essential. Call for assistance. Inject epinephrine 0.01 mg/kg in the mid-outer thigh (maximum 0.15 mg in an infant, 0.3 mg in a child, and 0.5 mg in a teenager). When

**BOX 58-7 ANAPHYLAXIS IN SCHOOLS****STUDENT'S RESPONSIBILITIES\***

Food-allergic students at risk of anaphylaxis:

- Avoid ingesting known food allergen(s), trading food with others, or eating snacks or treats containing unknown ingredients

All students at risk of anaphylaxis:

- Notify an adult immediately if inadvertently exposed to trigger or if symptoms develop
- Wear medical identification jewelry/carry an anaphylaxis identification card in backpack or wallet
- Carry an epinephrine auto-injector if age-appropriate and if permitted by local regulations

**FAMILY'S RESPONSIBILITIES\***

- Notify the school in writing of the student's risk for anaphylaxis and his/her confirmed trigger(s)
- Educate student about trigger avoidance
- Provide medical documentation from the student's physician, including a written, personalized, anaphylaxis emergency action plan
- Discuss the student's personalized anaphylaxis emergency action plan with school personnel
- Provide a properly labeled epinephrine autoinjector
- Replace epinephrine autoinjector after use, or if past expiry date
- Provide emergency contact information for parents/caregivers

**PHYSICIAN'S RESPONSIBILITIES\***

- Provide appropriate medical information to student and parents/caregivers
- Provide an accurate assessment of the student's risk of anaphylaxis recurrence

- Recommend relevant risk reduction strategies (e.g. allergen avoidance, venom immunotherapy)
- Prescribe an epinephrine auto-injector
- Train student and parents to recognize anaphylaxis and use epinephrine autoinjector
- Recommend medical identification jewelry/anaphylaxis identification card
- Develop a written, personalized, anaphylaxis emergency action plan with the student, and/or if age-appropriate, the parents/caregivers, listing allergen trigger(s), relevant concurrent co-morbidities such as asthma, and medications
- If the student has asthma, help him/her maintain optimal control of symptoms

**SCHOOL'S RESPONSIBILITIES\***

- Develop a comprehensive school policy for prevention, recognition and treatment of anaphylaxis that includes after-hours events and school-sponsored excursions
- Identify students at risk of anaphylaxis and review their health records<sup>†</sup>
- Identify a team: principal, teachers, school nurses, food service workers and food suppliers to help prevent anaphylaxis in the school
- Designate the school personnel who are trained to recognize anaphylaxis and administer epinephrine injections using EALs
- Rehearse the response to an anaphylactic episode: (1) call 9-1-1 or emergency medical services (EMS); (2) inject epinephrine promptly; (3) do not let the student sit up suddenly, walk or run; (4) lastly, contact parents/caregivers

Adapted from reference 146 and [www.foodallergy.org](http://www.foodallergy.org); [www.anaphylaxis.ca](http://www.anaphylaxis.ca); [www.whyriskit.ca](http://www.whyriskit.ca).

\*All information should be reviewed annually before the start of the school year and at additional intervals as needed, e.g. if an episode of anaphylaxis occurs, or if a student's allergen triggers change.

<sup>†</sup>Of the many students at risk for anaphylaxis in schools, those with milk, peanut, tree nut or shrimp allergy, and those with concomitant asthma are at highest risk for severe or fatal anaphylaxis.

needed, provide supplemental oxygen, administer IV fluids and initiate CPR. Mild anaphylaxis symptoms such as hives and cough can worsen with astonishing rapidity and progress to fatality within minutes.

Patients and caregivers should be prepared for recurrences of anaphylaxis in community settings through development and use of written, personalized, anaphylaxis emergency action plans that describe how to recognize symptoms promptly and inject epinephrine promptly using an EAL. Medical identification should be worn.

Long-term management focusses on prevention of anaphylaxis recurrences. It includes confirmation of anaphylaxis

triggers suggested by the history, vigilant avoidance of relevant triggers, and immune modulation where relevant, for example *Hymenoptera* venom immunotherapy.

Anaphylaxis education aims to increase awareness of the importance of prompt recognition and treatment of acute episodes and the need for prevention of anaphylactic episodes.

The complete reference list can be found on the companion Expert Consult website at <http://www.expertconsult.inkling.com>.

**KEY REFERENCES**

2. Simons FER, Arduoso LRF, Bilo MB, El-Gamal YM, Ledford DK, Ring J, et al. for the World Allergy Organization. World Allergy Organization guidelines for the assessment and management of anaphylaxis. *J Allergy Clin Immunol* 2011;127:593 e1–e22.
27. Simons FER, Sampson HA. Anaphylaxis: unique aspects of clinical diagnosis and management in infants (birth to age 2 years). *J Allergy Clin Immunol* 2015;135:1125–31.
35. Sicherer SH, Sampson HA. Food allergy: epidemiology, pathogenesis, diagnosis, and treatment. *J Allergy Clin Immunol* 2014;133:291–307.
74. Rudders SA, Banerji A, Clark S, Camargo CA Jr. Age-related differences in the clinical presentation of food-induced anaphylaxis. *J Pediatr* 2011;158:326–8.
83. Simons KJ, Simons FER. Epinephrine and its use in anaphylaxis: current issues. *Curr Opin Allergy Clin Immunol* 2010;10:354–61.
90. Choo KJL, Simons FER, Sheikh A. Glucocorticoids for the treatment of anaphylaxis. *Cochrane Database Syst Rev* 2012;4:CD007596.
98. Campbell RL, Bellolio MF, Knutson BD, Belamkonda VR, Fedko MG, Nestler DM, et al. Epinephrine in anaphylaxis: higher risk of cardiovascular complications and overdose after administration of intravenous bolus epinephrine compared with intramuscular epinephrine. *J Allergy Clin Immunol Pract* 2015;3:76–80.
121. Fleischer DM, Perry TT, Atkins D, Wood RA, Burks AW, Jones SM, et al. Allergic reactions to foods in preschool-aged children in a prospective observational food allergy study. *Pediatrics* 2012;130:e25–32.

## REFERENCES

1. Simons FER. Anaphylaxis: an overview of assessment and management. In: Leung DYM, Sampson HA, Geha R, Szefer SJ, editors. *Pediatric allergy: principles and practice*. 2nd ed. Edinburgh, UK: Saunders; 2010. p. 650–3.
2. Simons FER, Arduoso LRF, Bilo MB, El-Gamal YM, Ledford DK, Ring J, et al. for the World Allergy Organization. World Allergy Organization guidelines for the assessment and management of anaphylaxis. *J Allergy Clin Immunol* 2011;127:593 e1–e22.
3. Brown SGA, Kemp SF, Lieberman PL. Anaphylaxis. In: Adkinson NF Jr, Bochner BS, Burks AW, Busse WW, Holgate ST, Lemanske RF Jr, et al., editors. *Middleton's Allergy principles and practice*, vol. 2. 8th ed. Philadelphia, PA: Saunders; 2014. p. 1237–59.
4. Sampson HA, Munoz-Furlong A, Campbell RL, Adkinson NF Jr, Bock SA, Branum A, et al. Second symposium on the definition and management of anaphylaxis: summary report – Second National Institute of Allergy and Infectious Disease/Food Allergy and Anaphylaxis Network symposium. *J Allergy Clin Immunol* 2006;117:391–7.
5. Campbell RL, Hagan JB, Manivannan V, Decker WW, Kanthala AR, Bellolio MF, et al. Evaluation of National Institute of Allergy and Infectious Diseases/Food Allergy and Anaphylaxis Network criteria for the diagnosis of anaphylaxis in emergency department patients. *J Allergy Clin Immunol* 2012;129:748–52.
6. Decker WW, Campbell RL, Manivannan V, Luke A, St. Sauver JL, Weaver A, et al. The etiology and incidence of anaphylaxis in Rochester, Minnesota: a report from the Rochester Epidemiology Project. *J Allergy Clin Immunol* 2008;122:1161–5.
7. Simons FER, Sampson HA. Anaphylaxis epidemic: fact or fiction? *J Allergy Clin Immunol* 2008;122:1166–8.
8. Lin RY, Anderson AS, Shah SN, Nurruzzaman F. Increasing anaphylaxis hospitalizations in the first 2 decades of life: New York State, 1990–2006. *Ann Allergy Asthma Immunol* 2008;101:387–93.
9. Poulos LM, Waters AM, Correll PK, Loblay RH, Marks GB. Trends in hospitalizations for anaphylaxis, angioedema, and urticaria in Australia, 1993–1994 to 2004–2005. *J Allergy Clin Immunol* 2007;120:878–84.
10. Rudders SA, Arias SA, Camargo CA Jr. Trends in hospitalizations for food-induced anaphylaxis in US children, 2000–2009. *J Allergy Clin Immunol* 2014;134:960–2.
11. Gibbison B, Sheikh A, McShane P, Haddow C, Soar J. Anaphylaxis admissions to UK critical care units between 2005 and 2009. *Anaesthesia* 2012;67:833–9.
12. Sampson HA, Mendelson L, Rosen JP. Fatal and near-fatal anaphylactic reactions to food in children and adolescents. *N Engl J Med* 1992;327:380–4.
13. Bock SA, Munoz-Furlong A, Sampson HA. Further fatalities caused by anaphylactic reactions to food, 2001–2006. *J Allergy Clin Immunol* 2007;119:1016–18.
14. Pumphrey RSH, Gowland MH. Further fatal allergic reactions to food in the United Kingdom, 1999–2006. *J Allergy Clin Immunol* 2007;119:1018–19.
15. Huang F, Chawla K, Jarvinen KM, Nowak-Wegrzyn A. Anaphylaxis in a New York City pediatric emergency department: triggers, treatments, and outcomes. *J Allergy Clin Immunol* 2012;129:162–8 e3.
16. Silva R, Gomes E, Cunha L, Falcao H. Anaphylaxis in children: a nine years retrospective study (2001–2009). *Allergol Immunopathol (Madr)* 2012;40:31–6.
17. Hompes S, Kohli A, Nemat K, Scherer K, Lange L, Rueff F, et al. Provoking allergens and treatment of anaphylaxis in children and adolescents – data from the anaphylaxis registry of German-speaking countries. *Pediatr Allergy Immunol* 2011;22:568–74.
18. Orhan F, Canitez Y, Bakirtas A, Yilmaz O, Boz AB, Can D, et al. Anaphylaxis in Turkish children: a multi-centre, retrospective case study. *Clin Exp Allergy* 2011;41:1767–76.
19. De Swert LF, Bullens D, Raes M, Dermaux A-M. Anaphylaxis in referred pediatric patients: demographic and clinical features, triggers, and therapeutic approach. *Eur J Pediatr* 2008;167:1251–61.
20. de Silva IL, Mehr SS, Tey D, Tang MLK. Paediatric anaphylaxis: a 5 year retrospective review. *Allergy* 2008;63:1071–6.
21. Summers CW, Pumphrey RS, Woods CN, McDowell G, Pemberton PW, Arkwright PD. Factors predicting anaphylaxis to peanuts and tree nuts in patients referred to a specialist center. *J Allergy Clin Immunol* 2008;121:632–8.
22. Gonzalez-Perez A, Aponte Z, Vidaurre CF, Rodriguez LAG. Anaphylaxis epidemiology in patients with and patients without asthma: a United Kingdom database review. *J Allergy Clin Immunol* 2010;125:1098–104 e1.
23. Iribarren C, Tolstykh IV, Miller MK, Eisner MD. Asthma and the prospective risk of anaphylactic shock and other allergy diagnoses in a large integrated health care delivery system. *Ann Allergy Asthma Immunol* 2010;104:371–7.
24. Triggiani M, Montagni M, Parente R, Ridolo E. Anaphylaxis and cardiovascular diseases: a dangerous liaison. *Curr Opin Allergy Clin Immunol* 2014;14:309–15.
25. Valent P. Mast cell activation syndromes: definition and classification. *Allergy* 2013;68:417–24.
26. Alvarez-Twose I, Vano-Galvan S, Sanchez-Munoz L, Morgado JM, Matito A, Torreló A, et al. Increased serum baseline tryptase levels and extensive skin involvement are predictors for the severity of mast cell activation episodes in children with mastocytosis. *Allergy* 2012;67:813–21.
27. Simons FER, Sampson HA. Anaphylaxis: unique aspects of clinical diagnosis and management in infants (birth to age 2 years). *J Allergy Clin Immunol* 2015;135:1125–31.
28. Simons FER, Schatz M. Anaphylaxis during pregnancy. *J Allergy Clin Immunol* 2012;130:597–606.
29. Wolbing F, Fischer J, Koberle M, Kaesler S, Biedermann T. About the role and underlying mechanisms of cofactors in anaphylaxis. *Allergy* 2013;68:1085–92.
30. Robson-Ansley P, Du Toit G. Pathophysiology, diagnosis and management of exercise-induced anaphylaxis. *Curr Opin Allergy Clin Immunol* 2010;10:312–17.
31. Bauer CS, Kampitak T, Messieh ML, Kelly KJ, Vadas P. Heterogeneity in presentation and treatment of catamenial anaphylaxis. *Ann Allergy Asthma Immunol* 2013;111:107–11.
32. Khodoun MV, Strait R, Armstrong L, Yanase N, Finkelstein FD. Identification of markers that distinguish IgE- from IgG-mediated anaphylaxis. *Proc Natl Acad Sci U S A* 2011;108:12413–18.
33. Kishimoto TK, Viswanathan K, Ganguly T, Elankumaran S, Smith S, Pelzer K, et al. Contaminated heparin associated with adverse clinical events and activation of the contact system. *N Engl J Med* 2008;358:2457–67.
34. Zanoni G, Puccetti A, Dolcino M, Simone R, Peretti A, Ferro A, et al. Dextran-specific IgG response in hypersensitivity reactions to measles-mumps-rubella vaccine. *J Allergy Clin Immunol* 2008;122:1233–5.
35. Sicherer SH, Sampson HA. Food allergy: epidemiology, pathogenesis, diagnosis, and treatment. *J Allergy Clin Immunol* 2014;133:291–307.
36. Boyce JA, Assa'ad A, Burks AW, Jones SM, Sampson HA, Wood RA, et al. Guidelines for the diagnosis and management of food allergy in the United States: summary of the NIAID-sponsored expert panel report. *J Allergy Clin Immunol* 2010;126:1105–18.
37. Muraro A, Werfel T, Hoffmann-Sommergruber K, Roberts G, Beyer K, Bindslev-Jensen C, et al. EAACI Food Allergy and Anaphylaxis Guidelines: diagnosis and management of food allergy. *Allergy* 2014;69:1008–25.
38. Vetander M, Helander D, Flodstrom C, Ostblom E, Alfvén T, Ly DH, et al. Anaphylaxis and reactions to foods in children – a population-based case study of emergency department visits. *Clin Exp Allergy* 2012;42:568–77.
39. Liew WK, Chiang WC, Goh AE, Lim HH, Chay OM, Chang S, et al. Paediatric anaphylaxis in a Singaporean children cohort: changing food allergy triggers over time. *Asia Pac Allergy* 2013;3:29–34.
40. Vereda A, van Hage M, Ahlstedt S, Ibanez MD, Cuesta-Herranz J, van Odijk J, et al. Peanut allergy: clinical and immunologic differences among patients from 3 different geographic regions. *J Allergy Clin Immunol* 2011;127:603–7.
41. Zurzolo GA, Mathai ML, Koplin JJ, Allen KJ. Hidden allergens in foods and implications for labeling and clinical care of food allergic patients. *Curr Allergy Asthma Rep* 2012;12:292–9.
42. Taylor SL, Baumert JL. Cross-contamination of foods and implications for food allergic patients. *Curr Allergy Asthma Rep* 2010;10:265–70.
43. Chen JL, Bahna SL. Spice allergy. *Ann Allergy Asthma Immunol* 2011;107:191–9.
44. Mullins RJ, James H, Platts-Mills TAE, Commins S. Relationship between red meat allergy and sensitization to gelatin and galactose- $\alpha$ -1,3-galactose. *J Allergy Clin Immunol* 2012;129:1334–42 e1.
45. Chiang WC, Huang C-H, Llanora GV, Gerez I, Goh SH, Shek LPC, et al. Anaphylaxis to cow's milk formula containing short-chain galactooligosaccharide. *J Allergy Clin Immunol* 2012;130:1361–7.
46. Sanchez-Borges M, Suarez Chacon R, Capriles-Hulett A, Caballero-Fonseca F, Fernandez-Caldas E. Anaphylaxis from ingestion of mites: pancake anaphylaxis. *J Allergy Clin Immunol* 2013;131:31–5.



47. Kelso JM. Potential food allergens in medications. *J Allergy Clin Immunol* 2014;133:1509–18.
48. Chernin LR, Swender DA, Hostoffer RW, Tcheurekdjian H. Anaphylaxis secondary to contact with a vomited food allergen. *Ann Allergy Asthma Immunol* 2012;109:279.
49. Armentia A, Pineda F, Martin B, San Miguel A, Gil FJM, Puente Y, et al. Anaphylaxis caused by hidden soybean allergens in pillows. *J Allergy Clin Immunol* 2013;131:228–30.
50. Golden DB, Moffitt J, Nicklas RA, Freeman T, Graft DF, Reisman RE, et al. Stinging insect hypersensitivity: a practice parameter update 2011. *J Allergy Clin Immunol* 2011;127:852–4 e23.
51. Golden DBK, Kagey-Sobotka A, Norman PS, Hamilton RG, Lichtenstein LM. Outcomes of allergy to insect stings in children, with and without venom immunotherapy. *N Engl J Med* 2004;351:668–74.
52. Stritzke AJ, Eng PA. Age-dependent sting recurrence and outcome in immunotherapy-treated children with anaphylaxis to Hymenoptera venom. *Clin Exp Allergy* 2013;43:950–5.
53. Brown SGA, van Eeden P, Wiese MD, Mullins RJ, Solley GO, Puy R, et al. Causes of ant sting anaphylaxis in Australia: the Australian Ant Venom Allergy Study. *Med J Aust* 2011;195:69–73.
54. Cochran J, McSwain SD, Evans M, Webb S, Tecklenburg F. Anaphylaxis and delayed hymenoptera in a child with fire ant envenomation. *Am J Emerg Med* 2013;31:632 e1–e3.
55. Peng Z, Beckett AN, Engler RJ, Hoffman DR, Ott NL, Simons FER. Immune responses to mosquito saliva in 14 individuals with acute systemic allergic reactions to mosquito bites. *J Allergy Clin Immunol* 2004;114:1189–94.
56. Rappo TB, Cottee AM, Ratchford AM, Burns BJ. Tick bite anaphylaxis: incidence and management in an Australian emergency department. *Emerg Med Australas* 2013;25:297–301.
57. Khan DA, Solensky R. Drug allergy. *J Allergy Clin Immunol* 2010;125:S126–37.
58. Demoly P, Adkinson NF, Brockow K, Castells M, Chiriac AM, Greenberger PA, et al. International consensus on drug allergy. *Allergy* 2014;69:420–37.
59. Banerji A, Rudders S, Clark S, Wei W, Long AA, Camargo CA Jr. Retrospective study of drug-induced anaphylaxis treated in the emergency department or hospital: patient characteristics, management, and 1-year follow-up. *J Allergy Clin Immunol Pract* 2014;2:46–51.
60. Romano A, Caubet JC. Antibiotic allergies in children and adults: from clinical symptoms to skin testing diagnosis. *J Allergy Clin Immunol Pract* 2014;2:3–12.
61. Macy E, Ngor EW. Safely diagnosing clinically significant penicillin allergy using only penicilloyl-polylysine, penicillin, and oral amoxicillin. *J Allergy Clin Immunol Pract* 2013;1:258–63.
62. Sanchez-Borges M, Thong B, Blanca M, Ensina LF, Gonzalez-Diaz S, Greenberger PA, et al. Hypersensitivity reactions to non beta-lactam antimicrobial agents, a statement of the WAO special committee on drug allergy. *WAO J* 2013;6:18.
63. Hong DI, Dioun AF. Indications, protocols, and outcomes of drug desensitizations for chemotherapy and monoclonal antibodies in adults and children. *J Allergy Clin Immunol Pract* 2014;2:13–19.
64. Mertes PM, Alla F, Trechot P, Auroy Y, Jouglia E, and the Groupe d'Etudes des Reactions Anaphylactoides Peranesthesiques. Anaphylaxis during anesthesia in France: an 8-year national survey. *J Allergy Clin Immunol* 2011;128:366–73.
65. Brockow K, Ring J. Anaphylaxis to radiographic contrast media. *Curr Opin Allergy Clin Immunol* 2011;11:326–31.
66. Accetta Pedersen DJ, Klancnik M, Elms N, Wang ML, Hoffmann RG, Kurup VP, et al. Analysis of available diagnostic tests for latex sensitization in an at-risk population. *Ann Allergy Asthma Immunol* 2012;108:94–7.
67. Cox L, Lieberman P, Wallace D, Simons FER, Finegold I, Platts-Mills T, et al. American Academy of Allergy Asthma and Immunology/American College of Allergy, Asthma & Immunology Omalizumab-Associated Anaphylaxis Joint Task Force follow-up report. *J Allergy Clin Immunol* 2011;128:210–12.
68. Cox L, Nelson H, Lockey R, Calabria C, Chacko T, Finegold I, et al. Allergen immunotherapy: a practice parameter third update. *J Allergy Clin Immunol* 2011;127:S1–55.
69. Calderon MA, Simons FER, Malling HJ, Lockey RF, Moingeon P, Demoly P. Sublingual allergen immunotherapy: mode of action and its relationship with the safety profile. *Allergy* 2012;67:302–11.
70. Kelso JM, Greenhawt MJ, Li JT, Nicklas RA, Bernstein DI, Blessing-Moore J, et al. Adverse reactions to vaccines practice parameter 2012 update. *J Allergy Clin Immunol* 2012;130:25–43.
71. Greenberger PA, Lieberman P. Idiopathic anaphylaxis. *J Allergy Clin Immunol Pract* 2014;2:243–50.
72. Simons FER, Frew AJ, Ansotegui IJ, Bochner BS, Golden DB, Finkelman FD, et al. Risk assessment in anaphylaxis: current and future approaches. *J Allergy Clin Immunol* 2007;120:S2–24.
73. Harduar-Morano L, Simon MR, Watkins S, Blackmore C. Algorithm for the diagnosis of anaphylaxis and its validation using population-based data on emergency department visits for anaphylaxis in Florida. *J Allergy Clin Immunol* 2010;126:98–104.
74. Rudders SA, Banerji A, Clark S, Camargo CA Jr. Age-related differences in the clinical presentation of food-induced anaphylaxis. *J Pediatr* 2011;158:326–8.
75. Topal E, Bakirtas A, Yilmaz O, Karagol IHE, Arga M, Demirsoy MS, et al. When should we perform a repeat training on adrenaline auto-injector use for physician trainees? *Allergol Immunopathol (Madr)* 2014;42:472–5.
76. Jacobs TS, Greenhawt MJ, Hauswirth D, Mitchell L, Green TD. A survey study of index food-related allergic reactions and anaphylaxis management. *Pediatr Allergy Immunol* 2012;23:582–9.
77. Brown SGA, Stone SF, Fatovich DM, Burrows SA, Holdgate A, Celenza A, et al. Anaphylaxis: clinical patterns, mediator release, and severity. *J Allergy Clin Immunol* 2013;132:1141–9 e5.
78. Vadas P, Gold M, Perelman B, Liss G, Lack G, Blyth T, et al. Platelet-activating factor, PAF acetylhydrolase and severe anaphylaxis. *N Engl J Med* 2008;358:28–35.
79. Vadas P, Perelman B, Liss G. Platelet-activating factor, histamine, and tryptase levels in human anaphylaxis. *J Allergy Clin Immunol* 2013;131:144–9.
80. Belhocine W, Ibrahim Z, Grandne V, Buffat C, Robert P, Gras D, et al. Total serum tryptase levels are higher in young infants. *Pediatr Allergy Immunol* 2011;22:600–7.
81. Komarow HD, Hu Z, Brittain E, Uzzaman A, Gaskins D, Metcalfe DD. Serum tryptase levels in atopic and nonatopic children. *J Allergy Clin Immunol* 2009;124:845–8.
82. Sheikh A, Shehata YA, Brown SGA, Simons FER. Adrenaline for the treatment of anaphylaxis: Cochrane systematic review. *Allergy* 2009;64:204–12.
83. Simons KJ, Simons FER. Epinephrine and its use in anaphylaxis: current issues. *Curr Opin Allergy Clin Immunol* 2010;10:354–61.
84. Vadas P, Perelman B. Effect of epinephrine on platelet-activating factor-stimulated human vascular smooth muscle cells. *J Allergy Clin Immunol* 2012;129:1329–33.
85. Field JM, Hazinski MF, Sayre MR, Chameides L, Schexnayder SM, Hemphill R, et al. Part 1: executive summary: 2010 American Heart Association Guidelines for Cardiopulmonary Resuscitation and Emergency Cardiovascular Care. *Circulation* 2010;122:S640–56.
86. Sheikh A, Ten Broek V, Brown SGA, Simons FER. H<sub>1</sub>-antihistamines for the treatment of anaphylaxis: Cochrane systematic review. *Allergy* 2007;62:830–7.
87. Park JH, Godbold JH, Chung D, Sampson HA, Wang J. Comparison of cetirizine and diphenhydramine in the treatment of acute food-induced allergic reactions. *J Allergy Clin Immunol* 2011;128:1127–8.
88. Simons FER, Simons KJ. Histamine and H<sub>1</sub>-antihistamines: celebrating a century of progress. *J Allergy Clin Immunol* 2011;128:1139–50.
89. Nurmatov U, Rhatigan E, Simons FER, Sheikh A. H<sub>2</sub>-antihistamines for the treatment of anaphylaxis with and without shock: a systematic review. *Ann Allergy Asthma Immunol* 2014;112:126–31.
90. Choo KJL, Simons FER, Sheikh A. Glucocorticoids for the treatment of anaphylaxis. *Cochrane Database Syst Rev* 2012;4:CD007596.
91. Arroabarren E, Lasa EM, Olaciregui I, Sarasqueta C, Munoz JA, Perez-Yarza EG. Improving anaphylaxis management in a pediatric emergency department. *Pediatr Allergy Immunol* 2011;22:708–14.
92. Pumphrey RSH. Fatal posture in anaphylactic shock. *J Allergy Clin Immunol* 2003;112:451–2.
93. Dhami S, Panesar SS, Roberts G, Muraro A, Worm M, Bilò MB, et al. Management of anaphylaxis: a systematic review. *Allergy* 2014;69:168–75.
94. Pumphrey RSH. Lessons for management of anaphylaxis from a study of fatal reactions. *Clin Exp Allergy* 2000;30:1144–50.
95. Ben-Shoshan M, La Vieille S, Eisman H, Alizadehfar R, Mill C, Perkins E, et al. Anaphylaxis treated in a Canadian pediatric hospital: incidence, clinical characteristics, triggers, and management. *J Allergy Clin Immunol* 2013;132:739–41 e3.
96. Jarvinen KM, Sicherer SH, Sampson HA, Nowak-Wegrzyn A. Use of multiple doses of epinephrine in food-induced anaphylaxis in children. *J Allergy Clin Immunol* 2008;122:133–8.
97. Rudders SA, Geyer BC, Banerji A, Phipatanakul W, Clark S, Camargo CA Jr. Obesity is not a risk factor for repeat epinephrine use in



- the treatment of anaphylaxis. *J Allergy Clin Immunol* 2012;130:1216–18.
98. Campbell RL, Bellolio MF, Knutson BD, Bellamkonda VR, Fedko MG, Nestler DM, et al. Epinephrine in anaphylaxis: higher risk of cardiovascular complications and overdose after administration of intravenous bolus epinephrine compared with intramuscular epinephrine. *J Allergy Clin Immunol Pract* 2015;3:76–80.
  99. Sheikh A, Simons FER, Barbour V, Worth A. Adrenaline auto-injectors for the treatment of anaphylaxis with and without cardiovascular collapse in the community. *Cochrane Database Syst Rev* 2012;8:CD008935.
  100. Simons FER, Chan ES, Gu X, Simons KJ. Epinephrine for the out-of-hospital (first-aid) treatment of anaphylaxis in infants: is the ampule/syringe/needle method practical? *J Allergy Clin Immunol* 2001;108:1040–4.
  101. Rawas-Qalaji M, Simons FER, Collins D, Simons KJ. Long-term stability of epinephrine dispensed in unsealed syringes for the first-aid treatment of anaphylaxis. *Ann Allergy Asthma Immunol* 2009;102:500–3.
  102. Simons FER, Clark S, Camargo CA. Anaphylaxis in the community: learning from the survivors. *J Allergy Clin Immunol* 2009;124:301–6.
  103. Noimark L, Wales J, Du Toit G, Pastacaldi C, Haddad D, Gardner J, et al. The use of adrenaline autoinjectors by children and teenagers. *Clin Exp Allergy* 2012;42:284–92.
  104. Brown J, Tuthill D, Alfaham M, Spear E. A randomized maternal evaluation of epinephrine autoinjection devices. *Pediatr Allergy Immunol* 2013;24:173–7.
  105. Chad L, Ben-Shoshan M, Asai Y, Cherkaoui S, Alizadehfah R, St-Pierre Y, et al. A majority of parents of children with peanut allergy fear using the epinephrine auto-injector. *Allergy* 2013;68:1605–9.
  106. Simons FER, Edwards ES, Read EJ Jr, Clark S, Liebelt EL. Voluntarily reported unintentional injections from epinephrine auto-injectors. *J Allergy Clin Immunol* 2010;125:419–23.
  107. Topal E, Bakirtas A, Yilmaz O, Ertoyl IH, Arga M, Demirsoy MS, et al. A real-life study on acquired skills from using an adrenaline auto-injector. *Int Arch Allergy Immunol* 2013;160:301–6.
  108. Arga M, Bakirtas A, Catal F, Derinoz O, Harmanci K, Razi CH, et al. Training of trainers on epinephrine autoinjector use. *Pediatr Allergy Immunol* 2011;22:590–3.
  109. Camargo CA Jr, Guana A, Wang S, Simons FER. Auvi-Q versus EpiPen: preferences of adults, caregivers and children. *J Allergy Clin Immunol Pract* 2013;1:266–72.
  110. Edwards ES, Edwards ET, Simons FER, North R. Drug-device combination products in the 21st century: development using a human factors engineering approach. *Expert Opin Drug Deliv* 2015;12:751–62.
  111. Simons E, Sicherer SH, Simons FER. Timing the transfer of responsibilities for anaphylaxis recognition and use of an epinephrine auto-injector from adults to children and teenagers: pediatric allergists' perspective. *Ann Allergy Asthma Immunol* 2012;108:321–5.
  112. Simons E, Sicherer SH, Weiss C, Simons FER. Caregivers' perspectives on timing the transfer of responsibilities for anaphylaxis recognition and treatment from adults to children and teenagers. *J Allergy Clin Immunol Pract* 2013;1:309–11.
  113. Nurmatov U, Worth A, Sheikh A. Anaphylaxis management plans for the acute and long-term management of anaphylaxis: a systematic review. *J Allergy Clin Immunol* 2008;122:353–61.
  114. Perel P, Roberts I, Ker K. Colloids versus crystalloids for fluid resuscitation in critically ill patients. *Cochrane Database Syst Rev* 2013;2:CD000567.
  115. Mehr S, Liew WK, Tey D, Tang MLK. Clinical predictors for biphasic reactions in children presenting with anaphylaxis. *Clin Exp Allergy* 2009;39:1390–6.
  116. Simons FER. Pharmacologic treatment of anaphylaxis: can the evidence base be strengthened? *Curr Opin Allergy Clin Immunol* 2010;10:384–93.
  117. Jang DH, Nelson LS, Hoffman RS. Methylene blue for distributive shock: a potential new use of an old antidote. *J Med Toxicol* 2013;9:242–9.
  118. Cummings AJ, Knibb RC, King RM, Lucas JS. The psychosocial impact of food allergy and food hypersensitivity in children, adolescents and their families: a review. *Allergy* 2010;65:933–45.
  119. Shemesh E, Annunziato RA, Ambrose MA, Ravid NL, Mullarkey C, Rubes M, et al. Child and parental reports of bullying in a consecutive sample of children with food allergy. *Pediatrics* 2013;131:e10–17.
  120. Manassis K. Managing anxiety related to anaphylaxis in childhood: a systematic review. *J Allergy* 2012;2012:316296. doi:10.1155/2012/316296.
  121. Fleischer DM, Perry TT, Atkins D, Wood RA, Burks AW, Jones SM, et al. Allergic reactions to foods in preschool-aged children in a prospective observational food allergy study. *Pediatrics* 2012;130:e25–32.
  122. Nguyen-Luu NU, Ben-Shoshan M, Alizadehfah R, Joseph L, Harada L, Allen M, et al. Inadvertent exposures in children with peanut allergy. *Pediatr Allergy Immunol* 2012;23:133–9.
  123. Crotty MP, Taylor SL. Risks associated with foods having advisory milk labeling. *J Allergy Clin Immunol* 2010;125:935–7.
  124. Luccioli S, Kwegyer-Afful EK. Benefits of understanding allergen thresholds. *J Allergy Clin Immunol* 2014;134:399–400.
  125. Oude Elberink JNG, de Monchy JGR, van der Heide S, Guyatt GH, Dubois AEJ. Venom immunotherapy improves health-related quality of life in patients allergic to yellow jacket venom. *J Allergy Clin Immunol* 2002;110:174–82.
  126. Hernandez-Trujillo V, Simons FER. Prospective evaluation of an anaphylaxis education mini-handout: the AAAAI Anaphylaxis Wallet Card. *J Allergy Clin Immunol Pract* 2013;1:181–5.
  127. Mehl A, Niggemann B, Keil T, Wahn U, Beyer K. Skin prick test and specific serum IgE in the diagnostic evaluation of suspected cow's milk and hen's egg allergy in children: does one replace the other? *Clin Exp Allergy* 2012;42:1266–72.
  128. Sicherer SH, Wood RA, and the Section on Allergy and Immunology. Allergy testing in childhood: using allergen-specific IgE tests. *Pediatrics* 2012;129:193–7.
  129. Sicherer SH, Wood RA. Advances in diagnosing peanut allergy. *J Allergy Clin Immunol Pract* 2013;1:1–13.
  130. Sampson HA, Gerth van Wijk R, Bindslev-Jensen C, Sicherer S, Teuber SS, Burks AW, et al. Standardizing double-blind, placebo-controlled oral food challenges: American Academy of Allergy, Asthma & Immunology-European Academy of Allergy and Clinical Immunology PRACTALL consensus report. *J Allergy Clin Immunol* 2012;130:1260–74.
  131. Dang TD, Tang M, Choo S, Licciardi PV, Koplin JJ, Martin PE, et al. Increasing the accuracy of peanut allergy diagnosis by using Ara h 2. *J Allergy Clin Immunol* 2012;129:1056–63.
  132. Ford LS, Bloom KA, Nowak-Wegrzyn AH, Shreffler WG, Masilamani M, Sampson HA. Basophil reactivity, wheal size, and immunoglobulin levels distinguish degrees of cow's milk tolerance. *J Allergy Clin Immunol* 2013;131:180–6.
  133. Peters RL, Dharmage SC, Gurrin LC, Koplin JJ, Ponsonby AL, Lowe AJ, et al. The natural history and clinical predictors of egg allergy in the first 2 years of life: a prospective, population-based cohort study. *J Allergy Clin Immunol* 2014;133:485–91.
  134. Wood RA, Sicherer SH, Vickery BP, Jones SM, Liu AH, Fleischer DM, et al. The natural history of milk allergy in an observational cohort. *J Allergy Clin Immunol* 2013;131:805–12 e4.
  135. Lemon-Mule H, Sampson HA, Sicherer SH, Shreffler WG, Noone S, Nowak-Wegrzyn A. Immunologic changes in children with egg allergy ingesting extensively heated egg. *J Allergy Clin Immunol* 2008;122:977–83.
  136. Kim JS, Nowak-Wegrzyn A, Sicherer SH, Noone S, Moshier EL, Sampson HA. Dietary baked milk accelerates the resolution of cow's milk allergy in children. *J Allergy Clin Immunol* 2011;128:125–31.
  137. Brozek JL, Terracciano L, Hsu J, Kreis J, Compalati E, Santesso N, et al. Oral immunotherapy for IgE-mediated cow's milk allergy: a systemic review and meta-analysis. *Clin Exp Allergy* 2012;42:363–74.
  138. Nurmatov U, Venderbosch I, Devereux G, Simons FER, Sheikh A. Allergen-specific immunotherapy for peanut allergy. *Cochrane Database Syst Rev* 2012;9:CD009014.
  139. Jones SM, Burks AW, Dupont C. State of the art on food allergen immunotherapy: oral, sublingual, and epicutaneous. *J Allergy Clin Immunol* 2014;133:318–23.
  140. Wood RA, Sampson HA. Oral immunotherapy for the treatment of peanut allergy: is it ready for prime time? *J Allergy Clin Immunol Pract* 2014;2:97–8.
  141. Boyle RJ, Elremeli M, Hockenhull J, Cherry MG, Bulsara MK, Daniels M, et al. Venom immunotherapy for preventing allergic reactions to insect stings. *Cochrane Database Syst Rev* 2012;10:CD008838.
  142. Liu A, Fanning L, Chong H, Fernandez J, Sloane D, Sanch-Serra M, et al. Desensitization regimens for drug allergy: state of the art in the 21st century. *Clin Exp Allergy* 2011;41:1679–89.
  143. de Silva HA, Pathmeswaran A, Ranasinha CD, Jayamanne S, Samarakoon SB, Hitharage A, et al. Low-dose adrenaline, promethazine, and hydrocortisone in the prevention of acute adverse reactions to antivenom following snakebite: a randomised, double-blind, placebo-controlled trial. *PLoS Med* 2011;8:e1000435.
  144. Muraro A, Agache I, Clark A, Sheikh A, Roberts G, Akdis CA, et al. EAACI Food Allergy and

- Anaphylaxis Guidelines: managing patients with food allergy in the community. *Allergy* 2014;69:1046–67.
145. McIntyre CL, Sheetz AH, Carroll CR, Young MC. Administration of epinephrine for life-threatening allergic reactions in school settings. *Pediatrics* 2005;116:1134–40.
  146. Young MC, Munoz-Furlong A, Sicherer SH. Management of food allergies in schools: a perspective for allergists. *J Allergy Clin Immunol* 2009;124:175–82.
  147. Morris P, Baker D, Belot C, Edwards A. Preparedness for students and staff with anaphylaxis. *J Sch Health* 2011;81:471–6.
  148. Cicutto L, Julien B, Li NY, Nguyen-Luu NU, Butler J, Clarke A, et al. Comparing school environments with and without legislation for the prevention and management of anaphylaxis. *Allergy* 2012;67:131–7.
  149. Bailey S, Albardiaz R, Frew AJ, Smith H. Restaurant staff's knowledge of anaphylaxis and dietary care of people with allergies. *Clin Exp Allergy* 2011;41:713–17.
  150. Barnett J, Botting N, Gowland MH, Lucas JS. The strategies that peanut and nut-allergic consumers employ to remain safe when traveling abroad. *Clin Transl Allergy* 2012;2:12.

- A**
- Abatacept (Orencia®), 162
- Acquired antibody deficiency, 75
- Acquired cold urticaria, 460–461, 461*t*
- Acquired immunodeficiency syndrome (AIDS), 491
- Actemra®, 165
- Activation-induced cytidine deaminase (AID), 34, 34*f*
- Acute sinusitis
- antibiotics for, 235*t*
  - antimicrobial therapy in, 234–236
  - history and physical examination of, 233
  - microbiology of, 229–230, 230*t*
  - sinus surgery in, 236–237
- Acyclovir, 452–453
- AD. *see* Atopic dermatitis (AD)
- ADA. *see* Adenosine deaminase deficiency (ADA)
- ADA-deficient SCID, gene therapy for, 155–156, 155*f*
- Adalimumab (Humira®), 161–163
- ADAM33, 29*f*, 257
- Adaptive immunity
- atopic dermatitis and, 440
  - immunoglobulin therapy on, 150–151
- Adenoid hypertrophy, 237
- Adenoidectomy, 237
- Adenosine deaminase 2 (ADA2), deficiency of, 135*t*, 141
- Adenosine deaminase deficiency (ADA), 80, 85–86
- Adjacent tests, placement of, 182
- Adjuvants, immunotherapy, 208
- ADRB2, 27
- β<sub>2</sub>-adrenergic agonists, for asthma, in older children, 325
- Aeroallergens
- atopic dermatitis and, 444
  - immunotherapy for, 203–209
  - indoor, 191–195
  - measurements, of indoor environment, 174–175
  - outdoor, 185–190, 201
  - samplers, 187*t*, 188*f*
- Affirmations, 356
- Agammaglobulinemia, 143
- autosomal, 72
  - X-linked, 71–72
- Age, in prevalence of positive skin tests, 177–178
- Aggressive antiinflammatory therapy, 115
- AH50 assay, 98, 98*f*
- AID. *see* Activation-induced cytidine deaminase (AID)
- AIDS. *see* Acquired immunodeficiency syndrome (AIDS)
- Air pollution
- allergic diseases and, 4, 29*f*
  - indoor, 201, 305
- Airborne allergens. *see* Aeroallergens
- Airflow
- limitation, asthma, 268–269, 269*f*
  - in response to bronchodilators, 270
- Airway abnormalities, 65
- Airway responsiveness, heightened, asthma, 269–270
- Airways, spread of infection from upper to lower, 278
- Alcaftadine, 494*t*, 495
- Alexa488-ovalbumin, 434–435
- Alkalosis, respiratory, 270–271
- Allele-sharing methods test, 20
- Allergen
- delivery of, in oral immunotherapy, 431
  - exposure to, refractory asthma and, 347
- Allergen elimination diets, 420, 421*b*, 425–428
- Allergen exposure, 5
- Allergen extracts, 206–208, 207*t*
- administration and dosing, 207
  - duration of immunotherapy, 207
  - immunotherapy and, 209*b*
  - injection regimens in, 207
  - reactions to immunotherapy, 207–208
  - storage in, 207
- Allergen immunotherapy
- allergic rhinitis and, 217–218
  - for asthma, in older children, 325
  - for atopic dermatitis, 455
- Allergen-specific IgE antibody analysis, 172, 172*b*
- Allergenic foods
- avoidance *versus* early introduction of, 15
  - exposure to, 385–386
- Allergenic particles, submicronic, 185
- Allergens, 11–12, 167–168, 169*b*
- animal
    - control of, 198–199
    - environmental control, 198–199, 199*b*  - cat, 198
  - characterized, 186–187
  - cockroach, 199–200
  - by country or region, 421*t*
  - dog, 198
  - exposure
    - evaluation of, 194–195
    - thresholds for sensitization, 192*t*  - extracts, 206–208, 207*t*
  - in food, 420
  - general principles of, 185–187
  - immunotherapy for, 203–209
  - indoor, 191–195, 306
  - inhalant, 316–317
  - latex, 508, 509*t*
    - functional properties of, 508–510
    - immunologic properties of, 508  - mold, 200–201
  - nomenclature, 186–187, 191
  - outdoor, 185–190, 201
  - of particular importance in children, 477
  - peptides and recombinant, 208
  - rodent, 200
  - sampling, 187
  - secretion of, 384
  - structure and function of, 191–192, 192*f*
- Allergen-specific immunotherapy (AIT), 16
- Allergic bronchopulmonary aspergillosis, 247
- Allergic conjunctivitis, 484
- Allergic contact dermatitis, 467–468 *see also*
- Contact dermatitis
    - atopic dermatitis and, 469–470
    - effector T cells in, 469
    - of the hand, 471*f*
    - regulatory T-cells in, 469
    - T cell recruitment in, 468–469
- Allergic disease
- epigenetics and, 27–28
  - human, laboratory diagnosis of, 167–176
  - immune modulators, 208
  - immunotherapy for, 203–209
  - susceptibility genes for, 29*f*
  - undertaking genetic studies of, 18, 28*b*, 30*b*
- Allergic fungal sinusitis (AFS), 232
- Allergic inflammatory response, mechanisms of, 250–253, 251*f*
- Allergic march of childhood, 7
- Allergic proctocolitis, 405
- Allergic response
- early phase, 211
  - late phase, 211
- Allergic rhinitis (AR), 7, 14, 210–218, 218*b*, 288
- asthma and, 317
  - chronic cough, 245
  - developing ages in, 210
  - diagnosis
    - and management, 214–215, 215*f*
    - skin testing, 214, 214*t*  - diagnostic tests, 214
  - differential diagnosis of, 212–213
  - epidemiology of, 1, 210–211
  - evaluation and management of, 213–218
  - management of, 215–218
  - mechanism of action, immunotherapy for, 204–205
  - otitis media and, 226
  - pathophysiology of, 211–212
  - patient selection in, 206
  - risk factors of, 210
  - signs and symptoms of, 213*b*
  - sinusitis and, 232
  - skin tests and, 177, 180, 182–183
  - sublingual immunotherapy for, 433
- Allergic sensitization
- asthma, in older children, 315
  - definition of, 279–280
  - postnatal maturation of, 60–62
- Allergic shiners, 484–486, 486*f*
- Allergist/immunologist, indications for referral to, 214*b*
- Allergoids, 208
- Allergy, 11
- asthma, in older children, 312
  - diagnosis of, variables that influence, 172*b*
  - immune development and, 54–62
  - and infections, interactions between, 279–280
  - recurrent infections and, 63–64
- Allergy immunotherapy, skin test reactions and, 179
- Allergy skin testing, 177
- Alloimmune neonatal neutropenia (ANN), 102–103
- ALPS. *see* Autoimmune lymphoproliferative syndrome (ALPS)
- Alternaria, 189, 190*f*
- Aluminum, as allergen, 477
- Ambrosia species, allergic plant dermatitis and, 478
- Anakinra (Kineret®), 138, 163, 459
- Anaphylaxis
- assessment and management of, 524–536
  - in community setting, emergency preparedness to treat in, 531–533, 532*b*
  - emergency action plan for, 533
  - medical identification in, 533
  - self-injectable epinephrine in, 531–533

- Anaphylaxis (*Continued*)  
 definition of, 524  
 diagnosis of, 372, 526–527  
   clinical, 526–527, 527f  
   criteria for, 525b  
 differential diagnosis of, 527, 529b  
 drug-induced, 535  
 education for, 535  
 epidemiology of, 524  
 food-induced, 534–535  
 idiopathic, 461, 535  
 IgE-mediated allergy and, 399  
 impact of, 532f  
 insect sting-induced, 14, 535  
 to IVIG infusions, 148  
 laboratory tests for, 527  
 long-term management of, 530–535, 532f  
 mechanism of, 44–45  
 natural history of, 7, 14  
 observation and monitoring of, 530  
 pathologic mechanisms in, 524–526, 525f  
 patients at increased risk of, 524  
 pharmacologic prophylaxis of, 535  
 prevention of, in specific settings, 535  
   in physician's office or clinic, 535  
   in schools and community settings, 535, 536b  
 refractory, 530  
 risk of, 208  
 signs and symptoms of, in infants, 528t  
 treatment of, 527–530, 529b  
   epinephrine in, 527–529, 529b, 530t, 531b  
   isotonic saline in, 529, 529b  
   second-line medications for, 530  
   supplemental oxygen in, 529  
 triggers of, 526, 526b  
   avoidance of, 534  
   drugs and biologic agents, 534  
   exercise-induced, 526, 534  
   foods, 526, 534  
   immune modulation for, 534–535  
   investigations to confirm, 533–534, 533f  
   latex as, 526  
   medication, 526  
   stinging insects, 534  
   vaccines, 526  
   venom, 526
- Andersen cascade impactor, 187, 188f
- Angioedema, 458–466  
 acute, 460  
 chronic, 460–462  
 definition, 458, 459f  
 diagnostic procedures for, 463, 463b  
 differential diagnosis for, 459–462, 460f  
 epidemiology of, 458  
 etiology of, 458–459  
 evaluation of, 462–463  
 eye disease and, 491  
 hereditary, 95, 95f, 99, 459, 462  
   attacks in, 462  
   long-term prophylaxis of, 465–466, 466t  
   management of, 96–97  
   with normal C1INH gene and protein, 459, 463  
   prevalence of, 458  
   treatment of, 465, 465t  
 history of, 462–463  
 key concepts in, 459b  
 management of, 462–463  
 physical examination of, 463  
 recurrent, 463  
   complement evaluation of, 463t  
   treatment of, 464b
- Angiotensin-converting enzyme (ACE) inhibitors,  
 angioedema and, 462
- Animal, allergens and, 5
- Animal allergens  
 control of, 198–199  
 indoor, 193, 201  
 outdoor, 185
- Animal exposures, 12
- ANN. *see* Alloimmune neonatal neutropenia (ANN)
- Anti-IgE therapy, 174
- Anti-infection therapy, 282–283, 283f  
 for antibody deficiency, 78
- Anti-thyroglobulin antibodies, urticaria/  
 angioedema and, 459
- Antibiotic therapy  
 otitis media and, 224–225  
 sinusitis, 234–235
- Antibiotics  
 for antibody deficiency, 78  
 as risk factor for asthma, 5  
 use of, in asthma, 283–284
- Antibody, reference ranges for, 77t
- Antibody capacity, 183
- Antibody deficiency, 71–79  
 differential diagnosis of, 75, 75b, 76f  
 evaluation of, 75–78, 76f  
 with normal immunoglobulins, 74  
 treatment of, 78, 78b
- Antibody response, and immunotherapy, 204, 205f
- Anticholinergic agents, for asthma  
 exercise-induced, 341  
 in older children, 325–326
- Antigen-presenting cells (APCs)  
 asthma, 256  
 atopic dermatitis and, 441–442  
 B cells as, 59  
 immediate hypersensitivity response and, 167  
 immune development and, 55–56, 59–60  
 T helper cell differentiation and, 35
- Antigen sampling, mechanisms of, in intestinal  
 mucosa, 365–366
- Antihistamines, 480  
 allergic rhinitis and, 215–216  
 for anaphylaxis, 530, 530t  
 asthma pharmacologic intervention, 16  
 chronic cough and, 248–249  
 for eye diseases, 493–494  
 with multiple antiinflammatory activities,  
 494–495, 494t  
 second generation, 216t, 464, 465t  
 systemic, for atopic dermatitis, 453  
 third generation, 216t  
 for urticaria/angioedema, 464
- Antiinflammatory activity, of IVIG, 149–150
- Antiinflammatory therapy  
 principles of, 114–115, 114b  
 strategies for, 115–116, 115b  
   novel therapeutic targets in, 116  
   systemic immunosuppression in, 115–116
- Antimicrobial peptides, 443
- Antimicrobial antibodies, urticaria/angioedema  
 and, 459
- Antinuclear antibody (ANA), 117  
 test for, 120, 120t
- Antiviral immune responses, role of, 278–279
- APCs. *see* Antigen-presenting cells (APCs)
- APECED. *see* Autoimmune polyendocrinopathy,  
 candidiasis, ectodermal dystrophy (APECED)
- Apidae, 515
- Apoptosis  
 atopic dermatitis and, 442  
 IVIG effects on, 150
- Apoptotic cell, clearance of, 90
- Appraisal of guidelines, research and evaluation  
 (AGREE) process, 264–265
- Apurinic/aprimidinic endonuclease 1 (APE1),  
 34–35
- Aquagenic urticaria, 461t
- AR. *see* Allergic rhinitis (AR)
- Arachidonic acid metabolites, in inflammatory  
 response, 113
- ARACHILD trial, 435
- Arcalyst®, 165
- Arterial blood gases, asthma, 270–271
- Arterial values of pH, 271
- Arthralgia, familial Mediterranean fever and, 136
- Arthritis  
 familial Mediterranean fever and, 136  
 juvenile idiopathic, 116–118
- Aseptic meningitis, from IVIG, 147
- Aspiration syndrome, cough associated with,  
 246
- Association studies, 20, 24
- Asthma  
 acute, functional assessment of, 273  
 airway remodeling in, 257  
 anti-infection therapy for, 282–283, 283f  
 athletes, 336  
 chemokines and, 50  
 childhood, 276–277  
   to adulthood, 10, 10f  
 classification of severity and control, 319,  
 320t–321t  
 cough-variant, 241–242  
 definitive characteristics of, 268–271  
 development, 193  
 differential diagnosis, 339  
 environmental factors and, 279  
 epidemiology of, 1  
 epithelial cell activation and barrier function in,  
 257–258  
 epithelial-mesenchymal unit, 257  
 evaluation of, in older children, 314–316, 315f  
 exercise-induced, 336–342  
   areas for future research, 342  
   characteristic clinical features of, 338–339  
   diagnostics, 339–340  
   differential diagnosis of, 339  
   epidemiology of, 336  
   groups requiring special consideration, 339  
   impact, 336–337  
   pathophysiology of, 337–338  
   therapeutic agents for, 340–342, 340t, 341f  
 functional assessment of, 267–275  
   acute, 273  
   chronic, 273–274, 274f  
   diseases that masquerade as, 272–273, 273f  
   in infants and small children, 271–272  
 gastroesophageal reflux and, 317  
 gene-environment interactions in, 14–15  
 genetics, 21  
   gene-environment interactions, 6  
   in older children, 311–312  
   pharmacogenetics of, 27  
   phenotype of, 19  
   therapy response and, 27  
 guidelines for treatment of, 262–266  
   benefitted children and families, 264–266  
   development, 262  
   evidence-based medicine, 262–263, 263f,  
   263t  
   management of, children, 264, 265f  
 hygiene hypothesis, 12, 258  
 immunoglobulin E and, 38  
 infants and young children, 298–299  
   alternative and/or adjunct medications for,  
   295–297  
   confounding factors, 286, 287f  
   diagnostic tools for, 287–289  
   inhaled corticosteroids for, 294–295  
   management of, 289–298, 290t  
   monitoring disease activity and response,  
   292–297



- Asthma (Continued)**  
 predicting persistent, 285–286  
 special considerations for, 285–302  
 infections and, 276–284  
 acute exacerbations, 277  
 allergy and, 279–280  
 bacteria, 277  
 early life, 276–277  
 sinus, 277  
 treatment of, 280–283  
 viruses, 276–277  
 inflammation, measurement of, 288  
 inflammatory and effector cells and, 41  
 innate inflammatory mechanisms in, 255–257  
 inner city  
 community-wide coalitions, 309  
 interventions for, 306–309  
 management of, 303–304  
 prevalence of, 3  
 risk factors of, 3  
 strategies to reduce mortality and morbidity, 303–310, 304f, 304t  
 interventions for, inner city, 306–309  
 IVIG therapy on, 150–151  
 long-term management of, 265f  
 management and treatment, 346–347, 360–364, 361f  
 acute episodes of, 326, 327f  
 adherence, 298, 318–319, 354–359  
 allergen exposure as, 195  
 bronchoconstriction perception, 319–321  
 case management and care coordination, 331  
 challenges in schools, 330  
 collaboration in, 363  
 communication in, 330, 363  
 communication strategies, for changing patient behavior, 355–359  
 controller medications, 321–325  
 coordination in, 363  
 cost-effectiveness of strategies, 333–334  
 directly observed therapy, 331  
 education for, 347  
 in emergency department/hospital, 299  
 exacerbating phenotype, 351  
 exacerbations, 347  
 follow-up, 358–359, 359b  
 goals of, 321b  
 guidelines for, 264, 265f  
 harmonization in, 363  
 home, 298–299  
 infants and young children, 287f, 289–299, 290t  
 inner city, 303–304  
 managed care to organized care, 362  
 multidisciplinary team discussion, 347–348  
 in older children, 321  
 parental doublespeak, 347  
 personalized medicine, 362  
 pharmacological, 321, 322f  
 physical activity, 330  
 quick reliever medications for, 325–326  
 self-management, 354–359  
 self-management skills, 332  
 severity-based, 321  
 shared decision-making model, 357–358  
 steps in, 362–363  
 strategies to change patient behavior, 355  
 support systems for medical care, 362–363  
 time for patient encounters, 358  
 morbidity, 363–364  
 mortality, 363–364  
 natural history of, 7–17, 8f–9f, 276–284, 313–314  
 in older children, 311–328  
 differential diagnosis of, 314  
 epidemiology and etiology, 311–313  
 evaluation of, 314–316, 315f  
 factors influencing, 311–313, 312t
- Asthma (Continued)**  
 morbidity and mortality, 314  
 natural history of, 313–314  
 persistence and progression into adulthood, 313  
 prevalence of, 311  
 severity of, factors which increase, 316–319  
 treatment of, 321  
 onset of, 271  
 origins of, 363–364  
 parental history of, 11  
 past, present, future, 360–362, 361f  
 pathology of, 267  
 inflammatory cells, 267  
 patient selection in, 206  
 pharmacologic intervention of, 16  
 phenotypes of, 9b, 13, 19  
 physiology of, 267–268  
 airflow in response to bronchodilators, 270  
 arterial blood gases, 270–271  
 heightened airway responsiveness, 269–270  
 lung volumes, 270  
 prevalence of, 1–3, 2f  
 prevention of, in infants and young children, 299–301  
 prevention studies of, 15–16  
 protective influences of, 12–13  
 refractory, 343–353  
 co-morbidities, 344–345  
 differential diagnosis, 344, 344t  
 principles of, 343  
 problematic severe asthma, 343–350, 344t  
 rhinitis and, 317  
 risk factors of, 3, 10–12, 10b, 11f  
 infections, 11–12  
 inner city, 3, 303  
 role of respiratory viruses in, 258  
 school-centered programs for, 329–335, 334b  
 asthma care providers, in community, 334, 335t  
 asthma friendly schools, 332–333, 333t  
 evaluated strategies, 331  
 information technology infrastructure, 331–332  
 physical activity, 330  
 rescue therapy and, 330  
 severity and control, 263–264  
 sinusitis and, 232, 317  
 skin tests and, 177  
 sublingual immunotherapy for, 433  
 treatment and induction of immune tolerance, 258–259  
 use of antibiotics in, 283–284  
 viral illnesses and, 279  
 virus-induced cytopathic effects, 278, 278b  
 'Asthma-COPD overlap syndrome', 362  
 Asthma friendly schools, 332–333, 333t  
 Asthma predictive index (API), 286  
 Asthmatic inflammation (effector phase), 260f  
 Asthmatic response, immunology of, 250–261  
 Ataxia-telangiectasia (AT), 65t, 87  
 Athletes, contact dermatitis in, 479–480  
 Atopic dermatitis (AD), 288, 438–447, 447b  
 allergic contact dermatitis and, 469–470  
 autoallergens and, 445  
 chronic, 443  
 clinical features of, 439b  
 diagnosis of, 173, 438–439, 439f, 446f  
 clinical algorithm for, 450f  
 differential diagnosis of, 438–439, 449b  
 emotional stressors and, 452  
 environmental risk factors of, 4  
 epidemiology of, 1, 438  
 food allergy, 417  
 food allergy and, 414, 443  
 allergic triggers, 415b  
 clinical studies of, 416
- Atopic dermatitis (AD) (Continued)**  
 diagnosis of, 417–418, 418b, 418f, 418t–419t  
 epidemiology of, 417  
 laboratory investigation in, 415–416, 415b  
 management of, 418  
 natural history of, 418–419  
 onset and severity of, 415f  
 oral food challenges, 418  
 pathophysiology of, 414–415  
 prevention of, 416–417  
 genetic mutations in, food allergy, 414–415  
 genetics of, 439–443, 448  
 immunologic triggers of, 443–445  
 infectious agents and, 452–453, 452f  
 irritants and, 451  
 management of, 446f, 448–457  
 allergen immunotherapy for, 455  
 calcineurin inhibitors for, 450–451  
 control of pruritus in, 453  
 hydration in, 448–449  
 interferon- $\gamma$ , 456  
 intravenous immunoglobulin for, 455–456  
 omalizumab for, 456  
 patients and caregivers, education of, 454  
 phototherapy for, 453  
 proactive therapy for, 451  
 probiotics for, 456  
 skin barrier protective measures in, 448–449  
 sleep disturbance, control of, 453  
 systemic therapy for, 453–454  
 tar preparations for, 453  
 topical antiinflammatory therapy for, 449–451  
 topical glucocorticoids for, 449–450  
 triggering factors of, elimination of, 451–453  
 vitamin D for, 456  
 wet wrap therapy in, 454–455, 455f  
 multidisciplinary approach to, 455  
 natural history of, 7, 8f, 13, 14f  
 pathogenesis of, 414, 439  
 specific allergens and, 451–452  
 therapeutic principles for, 456b  
 Atopic Dermatitis Program (ADP), 455  
 Atopic disease, genetics of  
 heritability, 22  
 molecular regulation of, 22–27  
 susceptibility genes, 22–26  
 Atopic patch test (APT), 414  
 Atopic sensitization, prevalence of, 2f  
 Atopy  
 definition of, 22  
 heritability of, 22  
 molecular regulation of, 22–27  
 'Atopy patch tests', 376  
 Audiogram, 224  
 Auriculotemporal syndrome, 373  
 Autoallergens, 445  
 Autoimmune/chronic inflammatory disease, 64–65  
 Autoimmune disorders  
 IVIG in, 148–151, 149f  
 management of, 96  
 systemic, complement deficiency and, 90–91  
 Autoimmune lymphoproliferative syndrome (ALPS), 128–131, 128f, 129b  
 classification of, 130  
 clinical course of, 129, 129f  
 diagnosis and treatment of, 130–131, 130b  
 genetics and immunopathogenesis of, 130, 130f  
 laboratory findings in, 129, 129b  
 RAS associated, 131  
 Autoimmune neutropenia, primary and secondary, 103–104  
 Autoimmune polyendocrinopathy, candidiasis, ectodermal dystrophy (APECED), 124–125, 125b  
 Autoimmune regulator (AIRE), 124  
 Autoimmune syndromes, 73

- Autoinflammatory disorders, 133–142  
 familial Mediterranean fever, 136  
 features of, 133–136, 134*t*–135*t*  
 pathogenesis of, 136  
 recently discovered, 141
- Autophagy, 116
- Autosomal agammaglobulinemia, 72
- Autosomal recessive traits, inherited complement deficiencies and, 91
- Axillary dermatitis, 471–472
- Azathioprine  
 for atopic dermatitis, 454  
 for systemic lupus erythematosus, 121
- Azelastine, 494–495, 494*t*
- B**
- B cells, 47–48  
 antibody deficiency and, 71  
 as antigen-presenting cells, 59  
 atopic dermatitis and, 440–441  
 IgE  
 production of, 31, 34, 167  
 regulation of, 39  
 immune development and, 57, 59  
 IVIG effects on, 149  
 mucosal immunology and, 365, 366*f*, 368
- B regulatory cells, 255
- Bacitracin, 469–470
- Bacteria  
 asthma and, 277  
 exposure to, 12  
 infections from, atopic dermatitis and, 452  
 interactions with, 279
- Bacterial endotoxins, role of, 258
- Bacterial infections  
 in atopic dermatitis, 443  
 immune development and, 58  
 IVIG therapy for, 144–146  
 neutrophil disorders and, 101  
 recurrent, humoral immunodeficiency and, 71  
 sinusitis and, 229
- Baked egg tolerance, 426–427
- Baked milk tolerance, 426–427
- Balsam of Peru, 467
- Baseball players, 479
- Basiliximab (Simulect®), 163
- 'Basketball pebble fingers', 479
- Basketball players, 479
- Basophils, 41, 44–45, 44*b*  
 anaphylaxis and, 44–45  
 asthma, 256  
 food allergy and, 415  
 IL-4 sources, 36  
 immediate hypersensitivity response and, 167  
 immunotherapy, 204  
 IVIG effects on, 149  
 oral immunotherapy and, 433
- Bathing, for atopic dermatitis, 448
- BCL-6, IgE isotype switching and, 32
- Behavioral factors, for asthma, 305
- Bepotastine, 494, 494*t*
- Beta-lactam antibiotics, drug allergy to, 502
- Biologic therapies, 160–166, 161*t*
- Biological agents, for severe therapy-resistant asthma, 351
- Biologics, 160  
 approved, 161*t*–162*t*  
 nomenclature of, 161*t*  
 off-label, 162*t*  
 for pediatric therapeutic use, 162–165
- Biosimilars, 160
- Birch-fruit-vegetable syndrome, 410, 410*t*
- Birch tree pollen, 168, 186
- Bird fancier's disease, 247
- Blau syndrome, 135*t*, 139
- Bleach, in baths, 448, 452
- Blepharitis, 486*t*, 489–490, 490*t*
- Blood gases, arterial, asthma, 270–271
- Body mass index, food allergy and, 424
- Bone marrow transplantation  
 for DiGeorge syndrome, 87  
 for IPEX syndrome, 125
- Bordetella pertussis*, 243–244
- Bortezomib, for myeloma, 116
- Breast milk, 384, 405
- Breastfeeding, 4–5, 12–13, 15  
 in allergy prevention, 384, 416  
 immune development and, 58
- British Thoracic Society guidelines, 262
- Bronchial allergen challenges, 177, 184
- Bronchial challenge testing, 346
- Bronchial reactivity, measurement of, 288
- Bronchial stenosis, 245–246
- Bronchiolitis  
 acute viral, 243  
 respiratory syncytial virus, 11
- Bronchiolitis obliterans, 272
- Bronchitis, acute, 242
- Bronchoalveolar lavage (BAL), 267, 316
- Bronchodilator responsiveness, 346  
 persistent airflow limitation and, 346
- Bronchodilator therapy, for exercise-induced asthma, 339
- Bronchodilators  
 airflow in response to, 270  
 pharmacogenetics and, 27
- Bronchomalacia, 245–246
- Bronchoscopy, asthma, in older children, 316
- Bronchospasm, 241
- 'Bruton's agammaglobulinemia', 71
- Bruton's tyrosine kinase (BTK), 71
- Budesonide  
 for asthma  
 in infants and young children, 294–295, 294*t*  
 virus-induced, 281  
 for eosinophilic esophagitis, 403
- 'Building Bridges for Asthma Care', 363
- Bumblebees, 515
- Burkard spore trap, 187, 188*f*
- C**
- C1 esterase inhibitor (C1-INH) deficiency, 94–95, 95*f*
- C1INH replacement, 465
- C1q deficiency, 91–92, 92*f*
- C1r/C1s deficiency, 92
- C2 deficiency, 93
- C3 deficiency, 93
- C4 deficiency, 92–93
- C5 deficiency, 93
- C6 deficiency, 93–94
- C7 deficiency, 94
- C8 deficiency, 94
- C9 deficiency, 94
- Calcineurin inhibitors, 450–451
- Calcium-release activated channels (CRAC) deficiency, 84
- Canakinumab (Ilaris®), 161, 163
- Candidate genes, analysis of, 21, 24–26
- Candidiasis, mucocutaneous, 110, 124
- CAPS. *see* Cryopyrin-associated periodic syndromes (CAPS)
- Carbohydrates, need for, 424–425, 425*t*
- Carbon dioxide tension, asthma, 271
- Cardiopulmonary bypass, complement deficiency and, 97
- Care coordination, for asthma, 331
- Cartilage hair hypoplasia (CHH), 87
- Case management, for asthma, 331
- Caspase eight deficiency state (CEDS), 128–129
- Cat allergen, 5, 12, 168, 173, 193–194  
 clinical significance of, 193–194  
 environmental control, 198  
 measurement of, 174
- Cat asthma, immunotherapy for, 205
- Cathelicidin, 443
- CD3 deficiencies, 82
- CD4<sup>+</sup> T cells, 125  
 atopic dermatitis and, 440  
 immune development and, 55–56, 58  
 in irritant contact dermatitis, 468
- CD4<sup>+</sup> T lymphocytes, 365, 367  
 allergic rhinitis, 211  
 immunodeficiency of, 83
- CD4<sup>+</sup> Th2 cells, asthma, 250–251, 251*f*
- CD5, 59
- CD8<sup>+</sup> suppressor activity, immunotherapy, 204
- CD8<sup>+</sup> T cells  
 asthma, 257  
 atopic dermatitis and, 440  
 immune development and, 55–56, 60
- CD8<sup>+</sup> T lymphocytes, 365  
 immunodeficiency of, 83
- CD14, 15, 29*f*
- CD23, 31, 36, 38*f*  
 antigen capture and, 39  
 IgE regulation of, 31, 39  
 mucosal immunology and, 370  
 regulation of IgE, 38–39
- CD25 deficiency, 84, 127
- CD25<sup>+</sup> T cells, immune development and, 55
- CD27 deficiency, 84
- CD40/CD154  
 hyper-IgM syndromes, 88  
 IgE production, 33–35
- CD45 deficiency, 82
- CD45RA and CD45RO, 56
- Celecoxib, for juvenile idiopathic arthritis, 118
- Celeriac, 410
- Celeriac-mugwort-spice syndrome, 410, 410*t*
- Celiac disease, 394, 396*t*, 397, 398*b*, 458–459
- Cell-mediated immunity, evaluation of, 67–68, 68*f*
- Cellular activation, 52
- Cellular antiviral responses, outcome of viral infections and, 279
- Cellular receptor expression, 51
- Cellulitis, 491
- 'Cement burns', 479
- Ceramides, 449
- Cetirizine, 465*t*  
 asthma and, 300
- CF. *see* Cystic fibrosis (CF)
- CGD. *see* Chronic granulomatous disease (CGD)
- CH50 assay, 98, 98*f*
- Chalazion, 486*t*, 490
- 'Challenge gold standard,' of human allergic disease, 172
- Challenge testing, asthma, in older children, 316
- Chédiak-Higashi syndrome, 104, 104*f*
- Cheilitis, 471
- Chemoattraction, 51–52
- Chemokines, 41, 49, 50*f*, 51*b*  
 in allergic responses, 52*b*  
 asthma and, 50  
 atopic dermatitis and, 440, 442  
 ligands for, 50*f*  
 nomenclature of, 49  
 otitis media, 221  
 receptors, 46, 49–50, 257  
 immune development and, 57  
 mucosal immunology and, 367–368  
 WHIM syndrome and, 102  
 regulatory elements in, 51*f*
- Chemoprophylaxis, for antibody deficiency, 78
- Chemosis, 486*t*
- Chest pain, systemic lupus erythematosus and, 120

- Childhood Asthma Management Program (CAMP), 11, 317
- Children, management of asthma for, 264, 265f
- Chip-based microarray system, 168
- Chlamydia trachomatis* infection, 244
- Chlorofluorocarbon (CFC) propellant, 298
- Cholinergic urticaria, 460–461, 461t, 462f
- Chromate, as allergen, 477
- Chronic asthma, functional assessment of, 273–274, 274f
- Chronic granulomatous disease (CGD), 105–107, 154  
gene therapy for, 156–157  
prevalence of infection in, 105t
- Chronic hyperplastic sinusitis and nasal polyposis (CHS/NP), 231
- Chronic infantile neurologic cutaneous and articular syndrome (CINCA), 138
- Chronic rhinosinusitis (CRS), 229–230
- Chronic sinusitis  
antibiotics for, 235t  
antimicrobial therapy in, 236  
history and physical examination of, 233  
microbiology of, 230–231, 230t, 231f  
sinus surgery in, 236
- Chronic spontaneous urticaria, 460–461
- Cilia, evaluation of, 68–69
- Ciliary structure disorders, 65
- Cirrhosis, complement deficiency and, 97
- Class switch recombination (CSR), IgE and, 31–32
- Class switching, 74
- Climate change, on aeroallergens, 190
- ‘Clinical criteria gold standard,’ of human allergic disease, 172
- Clothing, antimicrobial, 451
- Cockroach allergen, 194  
clinical significance of, 194  
control of, 200  
environmental control of, 199–200, 200b  
inner city asthma, 3  
measurement of, 174–175  
skin test reactions to, 179
- Codeine, skin test reactions to, 178
- COL29A1*, 29f
- Colchicine, for familial Mediterranean fever, 136
- Cold compresses, 492–493
- Colic, infantile, 379, 381, 407
- Combined immunodeficiency, 80–86  
genetic and immunologic features of, 81t
- Common variable immunodeficiency (CVID), 72–73  
IVIG therapy for, 146
- Communication, 356  
asthma and, 330  
strategies, for changing patient behavior, 355–359
- Community-wide asthma coalitions, 309
- Complement deficiency, 75
- Complement system, 90  
classical pathway of, 92f  
deficiencies of, 90–100  
clinical presentations of, 99b  
hemolytic uremic syndrome in, 91  
infection in, 90  
inherited, 91–96, 91t  
laboratory assessment for, 98–99, 98f  
management of, 96–97  
secondary, 97–98  
SLE in, 90  
systemic autoimmune disorders in, 90–91  
evaluation of, 68  
functions of, 91t
- Complex genetic disease, 18  
identifying genes underlying, 18–21
- Compositae* family, allergic plant dermatitis and, 478
- ‘Composite gold standard,’ of human allergic disease, 172
- Compression syndromes, cough associated with, 245–246
- Confirmatory tests, IgE antibody, 171–173
- Confounding factors, wheezing, in infants and young children, 286, 287f
- Congenital disorder of glycosylation type IIc, 108
- Congenital immune dysregulation disorders, 124–132
- Conifer pollens, 187–188
- Conjugate pneumococcal vaccine, 76–77
- Conjunctiva, 482–483  
edema of, 486–487, 486f  
examination of, 486–487
- Conjunctival hyperemia, 488, 488f
- Conjunctival provocation test, 493
- Conjunctivitis, 491
- Conjunctivitis-otitis media syndrome, 484
- Connective tissue mast cells (CTMCs), 44, 60
- Constipation, 379–380, 407  
chronic, 372
- Contact dermatitis, 467–481  
allergens, 473–474  
selection of, in children, 474  
sources of, 473  
allergic, 468  
in athletes, 479–480  
and children, regional considerations in, 470–473  
clinical relevance, determination of, 476–477  
from cosmetics, 478–479  
diagnosis of, 470–473  
differential diagnosis of, 469  
epidemiology of, 467  
evaluation and management of, 469–470  
eyelid, 471  
haptens, innate immune recognition of, 468  
history of, 470  
irritant, 467–468, 470f  
of mucous membrane, 471  
patch testing, 473–477, 473t  
procedure for, 474–476  
recommendations for, 476t  
relevance of, 476t  
pathogenesis of, 467–469  
physical examination of, 470  
from plants, 478  
special considerations in, 478–480  
spectrum of, 469  
systemic, 472–473, 473t  
from topical medications, 478  
treatment and prevention of, 480
- Contact dermatoconjunctivitis, 490–491
- Contact lenses, 493
- Contact urticaria, 469
- Controller therapy, for small children with persistent asthma, 289–292, 291t, 292f, 293t
- Conventional ‘controller’ pharmacotherapy, for asthma, 16
- Cord blood, for transplantation, 153
- Cornea, examination of, 487, 487f
- Corneal transplantation, 491
- Coronin-1A deficiency, 83
- Corticosteroids  
for eosinophilic esophagitis, 403  
inhaled, for acute wheezing exacerbations, 281–282  
oral, for acute exacerbations of asthma, in young children, 280–281  
pharmacogenetics and, 27  
for rheumatologic diseases, 115  
skin test reactions and, 179  
structural groups of, 476b  
for urticaria/angioedema, 465
- Cosmetics, contact dermatitis to, 478–479
- Cough, chronic, 238–249  
allergic bronchopulmonary aspergillosis, 247  
allergic rhinitis, 245  
aspiration syndromes associated with, 246  
and bronchospasm, 241  
with compression syndromes, 245–246  
cough-variant asthma, 241–242  
cystic fibrosis, 247  
differential diagnosis of, 238–240, 239f, 240b  
environment and, 248  
evaluation of, 247–248, 249b  
foreign body, 246  
gastroesophageal reflux of, 238, 246  
hypersensitivity lung disease, 247  
pathophysiology of, 240–241, 240f–241f  
postnasal drip, 245  
psychogenic, 247  
respiratory infection after, 242–245  
rhinosinusitis, 245  
treatment of, 248–249  
vocal cord dysfunction, 247
- Cow’s milk allergy, 425–426, 426t–427t
- C-reactive protein (CRP), in systemic inflammation, 114, 114f
- Crohn’s disease, 139
- Cromolyn, 495  
for asthma, 296  
in older children, 324–325
- Cromolyn sodium  
allergic rhinitis and, 217  
for eosinophilic esophagitis, 403  
for eosinophilic gastroenteritis, 405
- Cross-reactive carbohydrate determinants (CCDs), 409, 517
- Cryopyrin, 138, 140f, 458–459
- Cryopyrin-associated periodic syndromes (CAPS), 137–138
- Cryptosporidium* infection, 88
- Cutaneous lymphocyte-associated antigen, 468–469
- Cyclic citrullinated peptide (CCP), 117
- Cyclic hematopoiesis, 102
- Cyclic neutropenia, 102
- Cyclosporin A, for atopic dermatitis, 454
- Cyclosporine  
for eye diseases, 496  
for urticaria/angioedema, 464–465
- Cystic fibrosis (CF), 65, 69  
chronic cough, 247  
sinusitis and, 232
- Cytidine 5’ triphosphate synthase 1 (CTPS1) deficiency, 84–85
- Cytokines  
asthma, 250–252  
atopic dermatitis and, 440–441  
chemokine regulation and, 50  
food allergy and  
eosinophilic esophagitis, 403  
eosinophilic gastroenteritis, 404  
mucosal immunology, 367–369  
oral immunotherapy, 433  
probiotics, 388  
food allergy and, atopic dermatitis, 414  
IgE and, 32–35  
production, 167  
immune development and, 55–57, 60  
natural history of, 7–8  
immunotherapy, 208  
in inflammatory response, 112–113  
otitis media, 221  
in pathogenesis of disease, atopic dermatitis, 414  
pathophysiology of, allergic rhinitis, 211  
T cell responses and, 35  
urticaria/angioedema and, 459

- Cytomegalovirus retinitis, 491  
 Cytoinductive conditioning, prior to HSCT, 153  
 Cytotoxic antibody, ocular inflammation, 483*t*
- D**
- Damage associated molecular patterns (DAMPs), 255
- Decongestants  
 allergic rhinitis and, 216  
 chronic cough, 248–249  
 for eye diseases, 493
- Deficiency of interleukin-1 receptor antagonist (DIRA), 134*t*, 139
- Deficiency of interleukin-36 receptor antagonist (DITRA), 134*t*, 141
- Delayed hypersensitivity, ocular inflammation, 483*t*
- Deletional switch recombination, IgE and, 31–32
- Demographic factors, asthma, older children, 312
- Dendritic cells (DCs), 46–47, 47*b*  
 asthma, 251*f*, 254*f*  
 atopic dermatitis and, 414, 440  
 food allergy and  
 mucosal immunology, 365, 367–368, 367*f*  
 food allergy and, atopic dermatitis and, 414  
 immune development and, 55, 59  
 IVIG effects on, 150–151  
 phenotype of, 35–36  
 T helper cell differentiation and, 35  
 Th cell differentiation and, 46, 46*f*
- Denosumab (Xgeva®), 163
- Dermatitis, IPEX syndrome and, 125
- Dermatitis herpetiformis, 394
- Dermatomyositis, IVIG and, 150
- Dermographism, 460–461, 461*t*, 462*f*
- Desensitization, definition of, 430
- Desloratadine, 465*t*
- Developing countries, 1–2
- Diabetes  
 food allergy and, 385–386  
 latex allergy and, 507
- Diagnostic tools, to evaluate asthma, in young children, 287–289
- Diaper dermatitis, 472
- Diarrhea  
 food allergy and, 380, 407  
 toddler's, 381
- Dickens, Charles, 360
- Diesel exhaust, 15
- Diet(s), 5  
 allergen elimination, 420, 421*b*, 425–428  
 asthma, older children, 313  
 exercise-induced asthma and, 342  
 infant, 385, 386*t*  
 intake assessment, 424  
 during lactation, 386*t*  
 lactation and, 416  
 mucosal immunity and, 369  
 during pregnancy, 313, 388
- Dietary protein enterocolitis, 392–393, 393*b*, 396–397, 396*t*, 398*b*
- Dietary protein enteropathy, 393, 396*t*, 397, 398*b*
- Dietary protein proctocolitis, 392, 394–396, 396*t*, 398*b*
- 'Difficult asthma', 347–348  
 severe therapy-resistant asthma and, 348
- DiGeorge syndrome (DGS), 65*t*, 86–87, 86*f*
- Dihydrorhodamine oxidation (DHR) assay, 106
- Diphtheria-tetanus-acellular pertussis (DTaP)  
 risk from disease vs. risk from, 243*b*  
 vaccine, 243
- Directly observed therapy, for asthma, 331
- DITRA. *see* Deficiency of interleukin-36 receptor antagonist (DITRA)
- DNA  
 gene therapy and, 158  
 genetic markers and, 20  
 IgE gene organization and, 31, 34–35  
 immunodeficiency syndromes with defective repair of, 87
- DOCK8 deficiency, 83, 110
- Dog allergen, 5, 193–194  
 clinical significance of, 193–194  
 environmental control of, 198  
 measurement of, 174
- Dog extracts, skin test reactions to, 179
- Domestic water supply, 4
- Double-blind, placebo-controlled food challenges (DBPCFCs), 374, 376, 416
- $\alpha/\beta$  double negative T cells (DNT), 128
- Doxepin hydrochloride, 453
- Drug allergy, 498–504  
 to beta-lactam antibiotics, 502  
 classification of, 499*t*  
 clinical history, evaluation of, 499–500  
 clinical manifestations of, 499  
 desensitization to, 501–502  
 drug provocation tests for, 500–501  
 in children, 501  
 contraindications of, 501  
 duration of, 501  
 general aspects of, 500–501  
 methodology of, 501  
 step dosing in, 501  
 epidemiology of, 498–499  
 incidence of, 499  
 multiple drug hypersensitivity syndrome, 504  
 to non- $\beta$ -lactam antibiotics, 502–503  
 to nonsteroidal antiinflammatory drugs (NSAIDs), 503  
 severity/danger signs in, 500*t*  
 skin tests for, 500  
 in children, 500  
 general aspects of, 500  
 to vaccines, 503–504  
 with local reaction after administration, diagnosis and management of, 504  
 with systemic reaction, management of, 504  
 work-up for, 499–502
- Drug-induced anaphylaxis, 535
- Drug provocation tests, for drug allergy, 500–501  
 in children, 501  
 contraindications for, 501  
 duration of, 501  
 general aspects of, 500–501  
 methodology of, 501  
 step dosing in, 501
- Dry-powder inhalers (DPIs), in infants and young children, 297
- DTaP vaccine, 243
- Durham sampler, 187
- Dust mites  
 allergy in, atopic dermatitis and, 451–452  
 control measures, 197–198  
 environmental control, 196–198  
 house, environmental control of, 197*b*
- Dust mites allergen, 192–193  
 clinical significance of, 192–193
- Dysfunctional breathing, refractory childhood asthma and, 345
- Dysmotile cilia syndromes, 65*t*
- Dysrhythmias, exercise-induced asthma and, 339
- E**
- E-selectin, 468–469
- Early-phase asthmatic response (EAR), 41, 42*f*
- East-West gradient, 2
- Eating competence, 424
- Ecallantide (Kalbitor®), 163–164  
 for angioedema, 97  
 hereditary, 465
- Ectopic contact dermatitis, 478
- Eculizumab (Soliris®), 164  
 for hemolytic uremic syndrome, 97
- Eczema, 468
- Eczema herpeticum, 452–453, 452*f*
- Eczema vaccinatum, 453
- Education  
 on food allergy, 420, 422  
 of patients and caregivers, in atopic dermatitis, 454
- Egg allergy, 426  
 atopic dermatitis and, 416, 419*t*  
 food labeling, 422  
 micronutrients and, 425  
 natural history of, 390, 418–419
- EIA. *see* Exercise-induced asthma (EIA)
- ELA2 gene, mutations in, 101
- Elimination diets, 420, 421*b*, 425–428
- Emergency department/hospital  
 for asthma, 299  
 interventions, inner city asthma and, 307
- Emollients, 449
- Enbrel®, 164
- Endochitinase (Hcv b 11), 510
- Endoscopic sinus surgery (ESS), 236
- Endotoxin exposure, 6, 12, 15
- Energy, need for, 424–425
- Enolase (Hcv b 9), 510
- Enterocolitis  
 dietary protein, 392–393, 393*b*, 396–397, 396*t*, 398*b*  
 food protein-induced, 378
- Enteropathy, dietary protein, 393, 396*t*, 397, 398*b*
- Environmental control, 196–202  
 of animal allergens, 199*b*  
 of cockroach allergen, 200*b*  
 of house dust mites, 197*b*  
 of mold allergens, 201*b*  
 of rodent allergens, 200*b*
- Environmental exposures, asthma, in older children, 317–318
- Environmental factors, asthma, in older children, 312
- Environmental interventions, inner city asthma, 308
- Environmental risk factors, 4–6  
 allergic rhinitis, 210, 215*t*  
 control of, 215  
 gene-environment interactions and, 6  
 genetics and, 29*f*  
 natural history studies and, 10
- Environmental tobacco smoke (ETS), 4, 12, 15  
 asthma and, 4, 9, 15, 305  
 chronic cough, 248  
 elimination/reduction of, 15–16  
 refractory asthma and, 347
- Enzyme immunoassay, 174
- Enzyme-linked immunosorbent assay (ELISA), allergen exposure, 195
- Eosinophil cationic protein (ECP), 41–42, 288
- Eosinophil-derived neurotoxin (EDN), 41–42
- Eosinophil peroxidase (EPO), 41–42
- Eosinophilic gastroenteropathies, 394, 399–407, 400*b*
- Eosinophils, 41–43, 42*f*, 43*b*  
 allergic rhinitis and, 211  
 asthma and, 43, 250  
 atopic dermatitis and, 440  
 immune development and, 60  
 immunotherapy, 204  
 otitis media and, 222
- Eotaxin, 51–52
- Epicutaneous immunotherapy (EPIT), 434–435



- Epidemiology of allergic diseases, 1–6  
time trends in prevalence of, 3–4
- Epigenetics, 27–28
- Epinastine, 494, 494*t*
- Epinephrine  
for acute anaphylactic episodes, 527–529, 529*b*, 530*t*, 531*b*  
for oral allergy syndrome, 412  
self-injectable, 531–533
- Epinephrine autoinjectors, for insect sting allergy, 520
- Epiphora, 486*t*
- Episcleritis, 490, 490*f*
- Epithelial cells  
activation of, in asthma, 257–258  
antiviral immune responses of, 278–279
- Epitopes, food allergy and, 376
- Erythrocyte sedimentation rate (ESR), in systemic inflammation, 114
- Esophagitis, eosinophilic, 372, 399–403  
characteristics of, 401*b*, 401*t*  
clinical manifestations of, 400  
complications of, 402  
diagnosis of, 400–402, 402*f*  
etiology of, 399–400  
evaluation of, 400–402, 402*f*  
management of, 402–403  
oral immunotherapy and, 433
- Etanercept (Enbrel®), 164  
for TRAPS, 137
- Ethnic minorities, asthma and, 303
- ETS. *see* Environmental tobacco smoke (ETS)
- Eucapnic voluntary hyperventilation, 340
- European Community Respiratory Health Survey (ECRHS), 2
- European Union, food labeling by, 421*t*
- Eustachian tube obstruction, 220–221, 222*t*  
types of, 221*b*
- Exercise, asthma, in older children, 319
- Exercise-induced anaphylaxis, 340  
co-triggers of, 526
- Exercise-induced asthma (EIA), 336–342  
areas for future research, 342  
characteristic clinical features of, 338–339  
diagnostics, 339–340  
differential diagnosis of, 339  
epidemiology of, 336  
groups requiring special consideration, 339  
impact, 336–337  
pathophysiology of, 337–338  
therapeutic agents for, 340–342, 340*t*, 341*f*
- Exercise-induced bronchoconstriction (EIB), 336  
pathogenesis of, disease model of, 338*f*
- Exhaled nitric oxide (eNO), level of, in asthma, 288
- Extracorporeal membrane oxygenation,  
complement deficiency and, 97
- Extrinsic allergic alveolitis, 174, 247
- Eye disease  
allergic disorders, 487–488  
giant papillary conjunctivitis, 488  
key concepts for, 497*b*  
perennial allergic conjunctivitis, 487–488  
seasonal allergic conjunctivitis, 487  
therapeutic principles for, 497*b*  
vernal keratoconjunctivitis, 488, 488*f*  
clinical signs of, 486*t*  
differential diagnosis of, 483, 484*f*, 485*t*  
examination in, 484–487  
eye anatomy and, 482–483, 483*f*  
histology of, 482–483  
history in, 484  
immune function of, 482–483  
immunologic, 488–492  
acquired immunodeficiency syndrome, 491  
angioedema, 491
- Eye disease (*Continued*)  
ataxia-telangiectasia, 491  
blepharitis, 489–490, 490*t*  
cellulitis, 491  
conjunctivitis, 491  
contact dermatitis, 490–491  
episcleritis, 490, 490*f*  
juvenile rheumatoid arthritis, 489  
Kawasaki's disease, 488–489  
sarcoidosis, 489  
uveitis, 489  
new directions and future developments in, 496  
ocular inflammation, categories of, 483*t*  
from transplantation, 491–492  
treatment of, 492–496, 492*t*  
antihistamines in, 493–494  
cold compresses, 492–493  
contact lenses, 493  
decongestants, 493  
environmental control in, 492  
immunotherapy in, 496  
lubrication in, 493  
primary intervention in, 492–493  
secondary intervention in, 493–495  
tertiary intervention in, 496  
topical corticosteroids in, 496
- Eyelid dermatitis, 471
- Eyelids, 482
- F**
- Facial dermatitis, 471
- Factor D deficiency, 96
- Factor H deficiency, 91, 95
- Factor I deficiency, 95–96
- FAHF-2, 436
- Failure to thrive, 380
- Familial cold autoinflammatory syndrome (FCAS), 134*t*, 138, 459, 461*t*
- Familial Mediterranean fever, 136
- Family size, 5–6
- Family studies, genetics, 19, 22
- Farming environments, 2–3, 6
- Fat, dietary, need for, 424, 425*t*
- Fc receptor, neonatal (FcRn), 370
- Fc receptors, immune modulation of, 148–150
- FCAS. *see* Familial cold autoinflammatory syndrome (FCAS)
- FcεRI, 31, 36–38, 37*f*  
atopic dermatitis and, 414, 441–442  
basophil expression of, 44  
IgE antibody and, 167  
IgE regulation of, 31, 38
- FcγRIIB, 149
- Feeding problems, approach to, in infant and young child, 377–382
- FERMT3* gene, mutations in, 108
- Fetal life, immune function during, 54–56
- Fetus, immune development of, 7–8
- Fever  
autoinflammatory disorders and, 133  
in systemic onset juvenile idiopathic arthritis, 117  
in TRAPS, 137
- Fexofenadine, 465*t*
- Filaggrin, 26, 257  
in atopic dermatitis, 448  
atopic dermatitis and, 439–440  
cat exposure and, 439–440
- Fingertip unit (FTU), 449
- Fish allergy  
food labeling, 422  
natural history of, 390, 418–419
- Fish oil, PUFA rich, 387
- Floristic zones, 186
- Flow cytometry, of LAD1, 107–108
- Fluticasone, for eosinophilic esophagitis, 403
- Food additives  
food labeling of, 421  
intolerance to, 377
- Food allergen  
atopic dermatitis, natural history, 13  
natural history, 13
- Food allergy  
anaphylaxis and, diagnosis of, 372  
atopic dermatitis and, 414, 443, 451  
allergic triggers, 415*b*  
clinical studies of, 416  
diagnosis of, 417–418, 418*b*, 418*f*, 418*t*–419*t*  
epidemiology of, 417  
laboratory investigation in, 415–416, 415*b*  
management of, 418  
natural history of, 418–419, 419*b*  
onset and severity of, 415*f*  
oral food challenges, 418  
pathophysiology of, 414–415  
prevention of, 416–417  
cardiovascular symptoms of, 372  
celiac disease and, 394, 396*t*, 397, 458–459  
daily living, 422–423  
diagnosis of, 173  
dietary protein enterocolitis and, 392–393, 393*b*, 396–397, 396*t*, 398*b*  
dietary protein enteropathy and, 393, 396*t*, 397, 398*b*  
dietary protein proctocolitis and, 392, 394–396, 396*t*, 398*b*  
differential diagnoses of, 380–381, 380*b*, 394  
eosinophilic gastroenteropathies and, 394, 399–407, 400*b*  
evaluation of, 371–376  
food challenges in, 376  
history in, 373  
in infants and young children, 381, 381*b*  
laboratory studies in, 373–376  
laboratory tests in, 381, 395*f*  
oral food challenges in, 418  
physical examination in, 373  
skin testing in, 373–374  
in vitro testing in, 374–376  
exposure to allergenic foods, 385–386  
first solids and, timing of, 385  
formula feeding for, 384–385  
gastrointestinal symptoms of, 372  
growth and, 423–424  
IgE-mediated symptoms of, 371–372, 372*b*  
cutaneous, 371  
immunomodulatory strategies for, 384–386  
breast milk, 384  
infant feeding, 384–386  
in infants and young children  
age at onset of symptoms, 377–378, 378*t*  
breastfeeding, 384  
clinical features of, 378, 378*t*  
differential diagnoses of, 380–381, 380*b*  
evaluation of, 381, 381*b*  
frequency of, 377  
gastrointestinal problems in, 378–380  
management of, 381  
natural history, 389–390  
prevention, 383–391  
timing of first solids, 385  
intervention for  
antenatal, 384  
importance and timing of early, 383–384  
postnatal, 384  
management of, 381, 420–429, 429*b*  
allergen elimination diets, 420, 425–428  
atopic dermatitis, 418  
avoidance diets, 420–423  
label reading, 420–422  
nutrition, 423–425  
oral food challenges, 428

- Food allergy (*Continued*)  
 maternal and infant microbiome and modulation of, 387–389  
 mechanism of action, immunotherapy, 206  
 mucosal immunology and, 365–370, 366f  
 natural history of, 7–8, 8f, 14, 389–390, 418–419  
 prevalence of, 371  
 prevention of, 383–391, 386t  
   phenotypic, environmental and genotypic risk in, 389  
 protein-induced enterocolitis, 378  
 protein-induced proctocolitis, 378  
 PUFA status and, restoration of traditional, 386–387  
 refractory childhood asthma and, 345  
 respiratory symptoms of, 372  
 treatment of, 397–398  
   immunotherapeutic approaches to, 430–437, 431f, 431t–432t  
   urticaria/angioedema and, 460  
   vitamin D for, 387
- Food extracts, skin test reactions to, 179–180
- Food hypersensitivity, diagnosis of, algorithm for, 375f
- Food-induced anaphylaxis, 534–535
- Food labeling, 420–421
- 'Food poisoning', 372
- Food-pollen allergy, 378
- Food protein-induced enterocolitis syndrome (FPIES), 378, 392–393, 396–397, 396t, 398b  
 oral food challenges for, 397t
- Food protein-induced proctocolitis, 378
- Foot dermatitis, 472, 472f
- Forced oscillation, 271–272
- Forced oscillometry, 288
- Formicids, 515
- Formoterol, in infants and young children, 296
- Formula feeding, 384–385
- FOXN1 defect, 83, 85
- FOXP3, 125, 126f, 128, 253–254, 414–415  
 oral immunotherapy and, 433
- FPIES. *see* Food protein-induced enterocolitis syndrome (FPIES)
- Fragrance, allergic contact dermatitis from, 478
- Frey's syndrome, 373
- Fruit allergy, concurrent latex allergy and, 507, 507t
- 'Functional antibody deficiency', 74
- Fungal exposures, 6
- Fungal infections, neutrophil disorders and, 101
- Fungi  
 allergen, 185  
 evaluation of, in indoor environments, 175  
 representative, 189, 190f
- G**
- G protein-coupled receptors (GPCRs), 49
- GALT. *see* Gastrointestinal associated lymphoid tissue (GALT)
- Gastroenteritis, eosinophilic, 403–405  
 characteristics of, 404b
- Gastroesophageal reflux disease (GERD)  
 asthma and, 317  
 chronic cough, 238, 246  
 food allergy and, 379, 379b  
 refractory childhood asthma and, 344–345  
 sinusitis and, 232
- Gastrointestinal associated lymphoid tissue (GALT), 365, 366f, 369, 384
- Gastrointestinal disease, allergic and eosinophilic, 399–408
- Gastrointestinal involvement, in systemic lupus erythematosus, 120
- Gastrointestinal (GI) microbiota, exposure to, 12
- Gastrointestinal reflux, food allergy and, 401t, 406–407
- Gastrointestinal symptoms, food allergy and, 378–380  
 celiac disease, 394, 396t, 397  
 dietary protein enteropathy, 393, 396t, 397, 398b  
 eosinophilic gastroenteropathies and, 394, 399–407, 400b  
 nonspecific, approach to potentially allergic infant with, 407  
 protein enterocolitis, 392–393, 393b, 396–397, 396t, 398b
- Gastrointestinal tract  
 chronic granulomatous disease in, 105  
 eosinophil accumulation in, 41  
 hereditary angioedema in, 95, 462  
 immune development of, 54  
 IPEX syndrome and, 414–415  
 mucosa and, 54  
 mucosal immunology and, 365  
 non-IgE mediated immune reactions in, in infants and young children, 378
- G-CSF receptor, mutations in, 101
- Gender, in asthma, 11
- Gene correction, 157–159, 158f
- Gene-environment interactions, 6, 14–15  
 asthma, older children, 312
- Gene organization, immunoglobulin E and, 31–32
- Gene therapy, using hematopoietic stem cells, 155–159, 155f  
 for ADA-deficient SCID, 155–156  
 for CGD, 156–157  
 gene correction in, 157–159, 158f  
 new approaches to, 157  
 perspectives for, 157  
 for WAS, 157  
 for X-linked SCID, 156
- Generalized dermatitis, 472–473
- Genetic mutations, in food allergy, 414–415
- Genetics  
 of allergic disease and asthma, 18–30  
 analytical approaches to, 20–21  
 asthma. *see* Asthma, genetics  
 clinically defined subgroups analysis of, 26  
 complement deficiency and, 91  
 disease heritability assessment of, 18–19  
 disease-modifying genes, 26–27  
 epigenetics, 27–28  
 gene identification in, 21–24  
 genetic markers in, 20  
 immunodeficiency diseases, antibody, 71  
 influences on disease severity, 26–27  
 phenotype definition in, 19, 22  
 population and, 20  
 predictive power of genetic testing, 28  
 susceptibility genes, 22–26, 28  
 T helper cells in, 35  
 therapy response regulation, 27
- Genitourinary tracts, chronic granulomatous disease in, 105, 106f
- Genome scanning, 21
- Genome-wide association studies (GWAS), 21–24, 23f
- Geographical pattern, of allergic disease, 2
- GERD. *see* Gastroesophageal reflux disease (GERD)
- German Contact Dermatitis Group (GCDG), 473  
 patch testing recommendations from, 476t
- German Infant Nutritional Intervention (GINI), 384–385
- German Multicentre Allergy Study (MAS), 7, 11–12
- $\epsilon$ -Germline transcription, 32, 33f
- GFI1* gene, neutropenia and, 102
- Giant papillary conjunctivitis, 488
- GINA. *see* Global Initiative for Asthma (GINA)
- Gleich syndrome, 459
- Gliadin, 394
- Global Initiative for Asthma (GINA), 262, 290–291, 293t, 296, 361, 363  
 assessment of asthma control, 264t, 290–291, 293t  
 guidelines, 289
- Global Lung Function Initiative (GLI), 268
- Glomerulonephritis, C3 deficiency and, 93
- Glucocorticoids  
 for anaphylaxis, 529b, 530, 530t  
 systemic, for atopic dermatitis, 453–454  
 topical, for atopic dermatitis, 449–450  
 side effects of, 449–450
- Glucose-6-phosphatase catalytic subunit 3 (G6PC3), mutations in, 101
- Glutathione-S-transferase genes (GSTM1), 29–30, 29f
- Glutathione S-transferases (GSTs), 15
- Glycerol thioglycolate, 479
- Glycosylation, type IIc, congenital disorder of, 108
- Graft *versus* host disease (GvHD), 152  
 conjunctival, 491–492, 491t
- Granular lymphocytosis, 102
- Granule formation/content, defects of, 104–105
- Granulocyte, immune development and, 60
- Granulocyte-colony stimulating factor (G-CSF), 102
- Granulocyte macrophage colony-stimulating factor (GM-CSF), 45, 441
- Granulomatous arthritis, pediatric, 139
- Grass, skin test reactions to, 178
- Grass pollen, 187  
 seasonal allergic conjunctivitis and, 487
- Growth, food allergy and, 423–424
- Growth charts, 423
- GSDML, 23, 29f
- Guadeloupe-type fever syndrome, 138
- Guidelines for the Diagnosis and Management of Asthma*, 361
- Guillain-Barré syndrome, IVIG therapy on, 150–151
- GWAS. *see* Genome-wide association studies (GWAS)
- H**
- HAE. *see* Hereditary angioedema (HAE)
- Hair products, allergy to, 479
- Hand dermatitis, 470–471, 471f
- Haptens, innate immune recognition of, 468
- HAX1 deficiency, 101
- Hay fever  
 epidemiology of, 1  
 prevalence of, 2f
- Hay fever, weed pollens, 189
- Health Beliefs Model, 356
- Health promotion, 356
- Healthcare workers, latex allergy in, 506
- Heightened airway responsiveness, asthma, 269–270
- Helminthic infections, 5
- Helminths, 54–55  
 eosinophil response to, 42f
- Hematopoiesis, 54  
 chemokine regulation and, 52  
 cyclic, 102
- Hematopoietic stem cell therapy (HSCT), 152–159, 155f  
 for chronic granulomatous disease, 154  
 donors for, 152–153, 154b  
 graft *versus* host disease in, 152  
 for hemophagocytic lymphohistiocytosis, 154  
 infections following, 152  
 for severe combined immune deficiency, 152–154, 153b

- Hematopoietic stem cell therapy (HSCT)  
(*Continued*)  
T cell in, depletion of, 152, 153*b*  
for Wiskott-Aldrich syndrome, 154
- Hematopoietic stem cell transplantation, for  
chronic granulomatous disease, 107
- Hemodialysis, complement deficiency and, 97
- Hemolytic adverse reactions, in IVIG therapy, 148
- Hemolytic uremic syndrome (HUS)  
complement deficiency and, 91, 95, 99  
management of, 97
- Hemophagocytic lymphohistio cytosis, 154
- Hepatic acute-phase response, 112–113, 113*f*–114*f*
- Hepatitis C virus infection, 148
- Hereditary angioedema (HAE), 95, 95*f*, 99, 459, 462  
attacks in, 462  
long-term prophylaxis of, 465–466, 466*t*  
management of, 96–97  
with normal C1INH gene and protein, 459, 463  
prevalence of, 458  
treatment of, 465, 465*t*
- Herpes simplex virus infection, 452–453
- Hevea brasiliensis*, 507  
latex allergens, 509*t*  
'Hibernian fever', 137
- HIES syndrome. *see* Hyper-IgE syndrome
- High-resolution computed tomographic (HRCT)  
scanning, 346
- Histamine  
in anaphylaxis, 527  
skin test reactions and, 179, 183
- History, asthma, in older children, 314–315
- HLA-B27 test, for juvenile idiopathic arthritis, 118
- HLA class I molecules, 84
- Hockey players, 480
- Home management, for asthma, 298–299
- Homeostasis, 36–39
- Honeybee, 514*f*  
stinger of, 515*f*
- Hordeolum, 486*t*
- Hornet, 174, 515
- Hospital visit, nurse-led, 345–347, 345*t*
- House dust  
aeroallergen measurement of, 174–175  
endotoxin, 12
- House dust mite allergen, 191  
environmental control of, 197*b*  
inner city asthma and, 306  
skin test reactions to, 178, 182–183
- HSCT. *see* Hematopoietic stem cell therapy (HSCT)
- Human allergic disease, laboratory diagnosis of,  
167–176
- Human immunodeficiency virus, evaluation for, 69
- Human immunoglobulin heavy chain, 33*f*
- Human leukocyte antigen (HLA), 84  
HSCT and, 152
- Human ligands, systematic names for, 51*t*
- Human 'nude' phenotype (FOXN1 defect), 83
- Human resource supplementation, of school health  
team, 331
- Humanized monoclonal anti-IgE, 435–436
- Humira®, 162–163
- Humoral immune responses, in intestine, 369–370,  
369*f*
- Humoral immunity, evaluation of, 67
- Humoral immunodeficiency, 71  
classification of, 72*t*
- HUS. *see* Hemolytic uremic syndrome (HUS)
- Hydration, 448–449
- Hydrolyzed formulas, 384–385, 392, 416
- Hydroxychloroquine, for malaria, 116
- Hygiene, 5–6
- Hygiene hypothesis, 12, 258
- Hymenoptera, 174, 513, 514*f*  
venom allergens of, 516*t*  
venom immunotherapy, 206
- Hyper IgD syndrome (HIDS), 137
- Hyper-IgE syndrome (HIES; Job's syndrome), 65*t*,  
110, 110*t*
- Hyper-IgM syndrome (HIGM), 34, 74–75, 88
- 'Hyper-IgM syndrome type 3' (HIM3), 74–75
- Hypersensitivity lung disease, chronic cough, 247
- Hypersensitivity pneumonitis, serum markers of,  
174
- Hypersensitivity response, immediate (type 1), 167,  
168*b*  
diagnosis of, 168–174, 170*b*
- Hypertension, systemic lupus erythematosus and,  
119
- 'Hypoallergenic' pets, 194
- Hypocomplementemia, 97
- Hypogammaglobulinemia  
IVIG therapy for, 144  
in WHIM syndrome, 102
- Hypoxemia, exercise-induced asthma and, 339
- I**
- Icatibant  
for angioedema, 97  
for hereditary angioedema, 465
- Idiopathic thrombocytopenic purpura (ITP),  
147–148
- I $\epsilon$  promoter, 32
- IgG subclass deficiency (IGGSD), 73–74
- IL-7R $\alpha$  deficiency, 82
- IL-21 receptor (IL-21R) deficiency, 84
- IL-33, 26, 29*f*
- IL1RL1, 29*f*
- IL2RG, 80–82
- IL13, 25, 29*f*
- Ilaris®, 163
- Immediate (type 1) hypersensitivity response, 167,  
168*b*  
diagnosis of, 168–174, 170*b*  
clinical history in, 169  
IgE antibody confirmatory tests in, 171–173  
laboratory methods for, 169–171, 170*b*  
variables that influence, 172*b*  
management of, 174–175, 175*b*
- Immediate-phase response (IPR), 252*f*
- Immune complexes  
complement system and, 90–91  
ocular inflammation, 483*t*
- Immune development, natural history studies of,  
7–9, 12
- Immune dysregulation, polyendocrinopathy,  
enteropathy, X-linked (IPEX) syndrome, 125,  
125*b*, 126*f*, 414–415
- Immune-mediated neutropenias, 102–104
- Immune modulating agent, IVIG as, 148–151,  
149*f*
- Immune modulation, for anaphylaxis triggers,  
534–535
- Immune response  
in allergic contact dermatitis, 468  
in allergic rhinitis, 211  
atopic, 29*f*  
in atopic dermatitis, 438–447  
to common enzymes, 510  
food allergy and  
IgE-mediated, 371–372, 372*b*  
non-IgE immune-mediated, 372–373, 372*b*  
IgE components of, 31–36, 32*b*  
inflammatory and effector cells and, 43  
to plant defense-related proteins, 509–510  
to rubber biosynthesis proteins, 508–509  
to sampled antigens in intestine, 366–367  
to structural proteins, 510
- Immune system  
in allergic response, 62*b*  
development of, 54–62
- Immune system (*Continued*)  
gastrointestinal tract and, 365  
maturation of, 55*b*  
neutrophil and, 58  
postnatal maturation of, 60–62
- Immune tolerance, asthma, 253–254, 258–259
- Immuno-osseous syndromes, 87
- Immuno-solid phase allergen chip (ISAC), 171
- Immunoassays, food allergy and, 374
- Immunodeficiency  
diagnosis of, 224  
IVIG treatment for, 150–151  
laboratory tests for, 66, 67*t*  
primary  
hematopoietic stem cell transplantation for,  
152  
immunoglobulin replacement therapy in,  
143–148, 151*b*  
recurrent infections and, 64, 64*b*, 65*t*  
T cell, 80–89
- Immunogenicity, of biologics, 160–161
- Immunoglobulin A (IgA)  
anaphylactic reactions and, 148  
celiac disease and, 394  
in IPEX syndrome, 125  
mucosal immunology and, 370
- Immunoglobulin A (IgA) deficiency, 73
- Immunoglobulin D (IgD), hyper, syndrome, 137
- Immunoglobulin E (IgE), 1  
allergen-specific, 8  
allergic rhinitis and, 210  
antibody confirmatory tests  
using defined positive cut-off point, 171–173  
using probability of clinical disease, 173–174  
atopic dermatitis and, 440–441  
defining atopy, 22  
disease mechanism principles of, 36–39, 37*b*  
food allergy and  
atopic dermatitis, 414  
differential diagnosis of, 372*b*  
in infants and young children, 378  
oral immunotherapy, 433  
food-specific, predictive value of, 374*t*  
immune development and, 57–58  
immune response components and, 31–36,  
32*b*  
allergen-specific, 35–36  
gene organization and, 31–32  
isotype switching, 32–35  
receptors, 36  
immunotherapy, 203–204  
in IPEX syndrome, 125, 127*b*  
IVIG therapy and, 148  
mucosal immunology and, 370  
natural history studies of, 8  
network of, 39*f*  
ocular inflammation, 483*t*  
regulation and biology of, 31–40  
sites of, 36  
skin tests in, 214*t*  
structure of, 31–32, 32*f*  
type 1 hypersensitivity and, 167
- Immunoglobulin E (IgE)-allergen binding, 183
- Immunoglobulin E (IgE) sensitization, insect sting  
allergy and, 518
- Immunoglobulin G (IgG)  
allergen-specific, 204  
anaphylaxis mediated and, 44–45  
food allergy and, 376  
immunotherapy, 204  
IVIG therapy and, 148  
mucosal immunology and, 370
- Immunoglobulin infusions, for severe therapy-  
resistant asthma, 351
- Immunoglobulin M (IgM), immune development  
and, 54–55, 59

- Immunoglobulin replacement therapy, 143–151  
 for antibody deficiency, 78  
 in primary immunodeficiency, 143–148, 144*b*  
 intravenous. *see* Intravenous immune serum globulin (IVIG)  
 principles of, 151*b*  
 subcutaneous, 146–147
- Immunoglobulins, reference ranges for, 77*t*
- Immunologic disorders, 488–492
- Immunology, of asthmatic response, 250–261  
 mechanisms of allergic inflammatory response, 250–253, 251*f*
- Immunomodulatory factors, in breast milk, 384
- Immunosuppressants  
 for APECED, 124–125  
 for IPEX syndrome, 125  
 for severe therapy-resistant asthma, 351
- Immunotherapy  
 allergen, for atopic dermatitis, 455  
 allergen-directed, 430–435, 432*t*  
 allergen extracts for, 206  
 allergen nonspecific, 432*t*, 435–436  
 for allergic disease, 203–209  
 allergic rhinitis, 204–205  
 antibody response and, 204, 205*f*  
 asthma, 205–206  
 epicutaneous, 432*t*, 434–435  
 for eye diseases, 496  
 future approaches to, 432*t*, 436  
 mechanism of action, 204  
 modified or recombinant allergen, 435  
 novel, 435  
 oral, 430–433, 432*t*  
 for oral allergy syndrome, 412  
 otitis media, 226  
 practical considerations in, 206–208  
 as prevention, 209  
 principles of, 203–204, 208*b*–209*b*  
 sublingual, 432*t*, 433–434  
 venom, 206  
 optimizing, 174
- Impaired NF-κB activation, T cell defects with, 84
- In vivo testing  
 for allergic disease, 167  
 for immunoglobulin E-mediated sensitivity, 177–184
- Indoor aeroallergens, 174, 175*b*
- Indoor air pollution, 201
- Indoor allergens, 191–195, 306  
 clinical significance of, 192–194  
 structure and function of, 192*b*
- Indoor environmental exposures, 305–306
- Induced pluripotent stem cells (iPS), 158–159
- Inducible urticaria, 460–461
- Inducing tolerance, immunotherapy, 208
- Infancy, virus-induced wheezing in, 280
- Infant feeding, 384–386
- Infant microbiome, modulation of, 387–389
- Infantile colic, 379, 381, 407
- Infections  
 allergic diseases and, 5–6, 9, 11–12  
 asthma, in older children, 313  
 autoimmune neutropenia and, 104  
 chronic cough, 242–245  
 complement deficiency diseases and, 90, 95–96  
 following hematopoietic stem cell therapy, 152  
 immune development and, 54–58  
 neutrophil disorders and, 101  
 recurrent, 64  
 IVIG therapy for, 144  
 in WHIM syndrome, 102  
 white blood cell defects and, 103*t*
- Infectious agents, atopic dermatitis and, 452–453, 452*f*
- Infectious complications, of IVIG therapy, 148
- Infectious diseases, prevention of, 96
- Inflammation, 112–113  
 airway, assessment of, in severe therapy-resistant asthma, 349  
 asthma, 250  
 measurement of, 288  
 atopic, 29*f*  
 immunoglobulin E and, 31  
 CD23 function, 39  
 FcεRI signaling, 38  
 systemic, assessing, 113–114
- Inflammatory and effector cells/cell migration, 41–53
- Inflammatory bowel disease (IBD), chronic  
 granulomatous disease and, 105–106
- Inflammatory cells  
 asthma, 267  
 effects on, 204  
 infiltration of, 442–443
- Inflammatory dendritic epidermal cells (IDECs), 441
- Inflammatory disorders, IVIG in, 148–151, 149*f*
- Inflammatory response, irritant contact dermatitis and, 468
- Infliximab (Remicade®), 164
- Influenza immunization, 298
- Information technology infrastructure, for asthma management, 331–332
- Inhalant allergens, 316–317  
 elimination/reduction of, 15
- Inhaled corticosteroids  
 for acute wheezing exacerbations, 281–282  
 adherence, 354  
 chronic cough, 248  
 for exercise-induced asthma, 340  
 fine particle, for severe, therapy-resistant asthma, 350  
 high dose, for severe, therapy-resistant asthma, 350  
 for infants and young children, 294–295  
 in older children, 323
- Inhaler devices, use of, in refractory asthma, 346–347
- Inheritance, genetics and, 19
- Innate immunity  
 atopic dermatitis and, 440  
 defects of, 101–111  
 therapeutic principles for, 111*b*  
 disorders of, 71  
 effects of immunoglobulin on, 150  
 in neonates, 58–59  
 otitis media, 221
- Innate lymphoid cells, 48, 48*f*
- Innate lymphoid cells type 2 (ILC2), asthma, 257
- Inner city asthma, 3, 199  
 interventions for, 306–309  
 emergency department, 307  
 environmental, 308  
 multifactorial, 308–309  
 provider targeted, 307–308  
 school-based, 307  
 technology-based, 308  
 therapy, 306, 307*f*  
 management of, 303–304  
 strategies to reduce mortality and morbidity, 303–310, 304*f*, 304*t*  
 access to care, 305  
 adherence, 304–305, 305*b*  
 indoor environmental exposures, 305–306  
 knowledge and patterns of, 304  
 obesity, 306  
 outdoor environmental exposures, 306  
 psychosocial factors, 305
- Insect sting allergy, 513–523  
 acute reactions  
 prevention of, 520–523, 520*b*  
 therapy for, 520  
 anaphylaxis and, 14
- Insect sting allergy (*Continued*)  
 biting insects, 513  
 development of, 517  
 epidemiology of, 517  
 etiology of, 517  
 IgE sensitization and, 518  
 introduction, 513  
 large local reactions, 517  
 natural history of, 518  
 therapy for, 520  
 natural history of, 518–519  
 of insect sting anaphylaxis, 518  
 reactions to  
 classification of, 517–518  
 normal, 517  
 severity of, 518–519  
 stinging insects, 513–515, 514*f*  
 Apidae, 515  
 Formicids, 515  
 Vespidae, 514–515, 514*t*  
 systemic reactions, 518  
 therapy for, 520  
 toxic reactions, 517–518  
 unusual reactions, 518  
 venom in, 515–517, 516*t*  
 cross-reactivity of, 517  
 venom-specific IgE, diagnosis and detection of, 519–520  
 history of, 519, 519*b*  
 sting challenge tests for, 520  
 tryptase for, 520  
 venom skin tests in, 519  
 in vitro measurement of, 519
- Insect sting-induced anaphylaxis, 535
- Interferon-α/β, 442
- Interferon-γ (IFN-γ)  
 allergic disease and, 9, 12  
 asthma, 253  
 atopic dermatitis and, 440–441, 456  
 immune development and, 7–8, 55–58
- Interleukin-1 receptor antagonist, 137, 459  
 deficiency of, 139
- Interleukin-2 (IL-2), signaling defects in, 127–128, 127*f*
- Interleukin-3 (IL-3), 44
- Interleukin-4 (IL-4)  
 allergen-specific T cell responses and, 35  
 asthma, 251  
 atopic dermatitis and, 440–441  
 IgE and, 32–33  
 immune development and, 57, 59  
 mucosal immunology and, 367  
 non-T cell sources of, 36
- Interleukin-5 (IL-5)  
 asthma, 251  
 atopic dermatitis and, 440–441  
 immune development and, 57–58
- Interleukin-6 (IL-6), 58  
 asthma, 254
- Interleukin-7 (IL-7), immune development and, 56
- Interleukin-9 (IL-9), asthma, 255
- Interleukin-10 (IL-10)  
 immune development and, 55, 57–58  
 mucosal immunology and, 367–368
- Interleukin-12 (IL-12)  
 atopic dermatitis and, 441  
 immune development and, 57–58
- Interleukin-13 (IL-13)  
 asthma, 251–252  
 atopic dermatitis and, 440–441  
 IgE and, 32–33  
 non-T cell sources of, 36  
 polymorphisms and, 25
- Interleukin-17 (IL-17), 58  
 asthma, 253  
 contact dermatitis, 469



- Interleukin-18 (IL-18), 58–59  
 Interleukin-21 (IL-21), 32, 57–58  
 Interleukin-23 (IL-23)  
   asthma, 254–255  
   immune development and, 58  
   Th17 cells, 254–255  
 Interleukin-25 (IL-25; IL17E), 255–256  
 Interleukin-31 (IL-31), 442–443  
 Interleukin-33 (IL-33), 26, 29f  
   asthma, 256  
 Interleukin-36 receptor antagonist, deficiency of, 141  
 International Study of Asthma and Allergy in Childhood (ISAAC), 1–2, 3f, 11  
 Interstitial lung disease (ILD), 272  
 Intracutaneous test, 180–181  
 Intradermal testing, 180  
 Intraepithelial lymphocytes (IELs), 365, 366f  
 Intranasal corticosteroid sprays, 216–217, 216t  
 Intravenous immune serum globulin (IVIG)  
   administration of, 146–147  
   antibodies in, half-life of, 144  
   for atopic dermatitis, 455–456  
   in autoimmune or inflammatory disorders, 148–151, 149f  
   dosage for, 144–146  
   preparation of, 143–144, 144b, 145t  
   principles of, 151b  
   for rheumatologic diseases, 115–116  
   for SCID, 86  
   SCIG *versus*, 146  
   side-effects of, 147–148, 147b  
     anaphylactic reactions, 148  
     hemolytic adverse reactions, 148  
     infectious complications, 148  
     rate-related adverse reactions, 147  
     renal adverse effects, 147–148  
     thromboembolic events, 148  
 IPEX syndrome, 125, 125b, 126f, 414–415  
 Ipratropium bromide, allergic rhinitis and, 217  
 IRAKM, 29f  
 Irritable bowel syndrome (IBS), 381  
 Irritant contact dermatitis, 467–468, 470, 470f  
 Irritants, environmental, refractory asthma and, 347  
 Isohemagglutinins, 75–76  
 Isolated lymphoid follicles (ILFs), 365, 366f
- J**  
 JAK-3 deficiency, 82  
 JIA. *see* Juvenile idiopathic arthritis (JIA)  
 Job's syndrome. *see* Hyper-IgE syndrome  
 Joggers, contact dermatitis in, 479  
 Juvenile dermatomyositis, 121–122, 122f  
 Juvenile idiopathic arthritis (JIA), 116–118  
   laboratory assessment of, 117–118  
   prognosis of, 118  
   systemic onset, 117  
   treatment of, 118  
 Juvenile myelomonocytic leukemia (JMML), 131  
 Juvenile rheumatoid arthritis, 489
- K**  
 Kaiser San Diego study, 7, 11  
 Kalbitor®, 163–164  
 Kawasaki's disease, 488–489  
   IVIG therapy on, 150–151  
 Keratinocytes  
   apoptosis of, 468  
   atopic dermatitis, 441, 443  
 Keratitis, 486t  
 Ketorolac tromethamine, 495  
 Ketotifen, 494, 494t  
   asthma and, 300
- Killer bees, 515  
 Kineret®, 163  
 Kiwi allergy, sublingual immunotherapy for, 433
- L**  
 LABAs. *see* Long-acting  $\beta$ -agonists (LABAs)  
 Laboratory assessment  
   of juvenile idiopathic arthritis, 117–118  
   of systemic lupus erythematosus, 120–121  
 Laboratory diagnosis, of human allergic disease, 167–176  
 Laboratory evaluation  
   asthma, in older children, 315  
   of neutrophil disorder, 101, 103t  
 Laboratory investigation, for allergic disease, food allergy, 415–416  
 Laboratory studies, for allergic diseases, food allergy, 373–376  
 Laboratory tests  
   for allergic disease, food allergy, 381, 395f  
   for recurrent infections, 66–69  
 Lactobacilli, 388–389  
 Lactose intolerance, 373, 380–381  
 Langerhans cells, allergic contact dermatitis and, 468  
 'Late-onset wheezers', 285–286  
 Late-phase asthmatic response (LAR), 41, 42f, 44  
 Late-phase response (LPR), immunoglobulin E and, 38  
 Lateral flow test, point-of-care IgE antibody, 171  
 Latex allergy, 169, 505–512  
   allergens in, 508, 509t  
   functional properties of, 508–510  
   immunologic properties of, 508  
   clinical manifestations of, 505–507, 506f  
   concurrent, fruit allergy and, 507, 507t  
   diabetes and, 507  
   diagnosis of, 510–511, 511f  
   in general population, 506–507  
   in healthcare workers, 506  
   and latex collection, 508  
   latex product manufacturing and, 508  
   and latex production, 507–508  
   in patients with urologic or neurologic defects, 506  
   prevention and treatment of, 512  
   skin testing for, 510  
   spina bifida and, 505–506  
   in surgery, 506  
   in vitro testing for, 510–511  
   in vivo provocation testing for, 511  
 Latex esterase (Hev b 13), 510  
 Latex-fruit syndrome, 410t, 411  
 Leg dermatitis, 472  
 Lentiviral vectors, for gene therapy, 157  
 Leukocoria, 486t  
 Leukocyte adhesion deficiency  
   type 1 (LAD1), 107–108, 107t, 108f  
   type 2 (LAD2), 108  
   type 3 (LAD3), 108  
 Leukocytes  
   allergic inflammation and, 41  
   antiviral immune responses of, 279  
   chemokine regulation of, 51–52  
   migration of, 49, 49f  
   recruitment of, 48–51  
   trafficking of, 49b  
 Leukotriene biosynthetic pathway, 27  
 Leukotriene modifiers, in older children, 323–324  
 Leukotriene modifying agents, for asthma, 296  
 Leukotriene receptor antagonists (LTRAs)  
   allergic rhinitis and, 217  
   for asthma, exercise-induced, 340  
   for eosinophilic esophagitis, 403  
   for eosinophilic gastroenteritis, 405
- Leukotrienes modifiers, role in virus-induced wheezing, 282  
 Ligase IV (LIG4) deficiency, 87  
 Limbal conjunctivitis, 487, 487f  
 Linkage analysis, genetics, 20  
 Linkage disequilibrium (LD), 25  
 Lipid transfer protein (Hev b 12), 510  
 Lipid transfer protein syndrome, 410, 410t  
 Lipocalin, 169b  
 Listening  
   focusing on, 356–357  
   reflective, 356, 357t  
 Liver, immune development of, 54  
 Liver abscesses, chronic granulomatous disease and, 105  
 Local allergy, skin tests for, 182–183  
 Localized heat urticaria, 461t  
 Lodoxamide, 495  
 Long-acting  $\beta$ -agonists (LABAs)  
   for exercise-induced asthma, 340–341  
   inhaled, in infants and young children, 296–297  
   in older children, 324  
 Loratadine, 465t  
 Loteprednol, 496  
 Louis-Bar's syndrome, 491, 491f  
 LTRAs. *see* Leukotriene receptor antagonists (LTRAs)  
 Lubrication, for eye diseases, 493  
 'Lucky Luke' contact dermatitis, 472  
 Lung, cell trafficking, 257  
 Lung clearance index (LCI), 272  
 Lung disease, hypersensitivity, 247  
 Lung function  
   assessments of, asthma, 272–274  
   asthma and, 9–10  
   exercise-induced, 340  
 Lung volumes, 270  
 Lupus nephritis, 119  
 Lyell's syndrome, 150  
 Lymphocytes, 47  
   apoptosis pathways of, 130f  
   immune development and, 55  
   mucosal immunology and, 368  
 Lymphocytosis, granular, 102
- M**  
 Macrolide antibiotics, for severe therapy-resistant asthma, 350–351  
 Macrolides, allergy to, 502–503  
 Macrophage colony-stimulating factor (M-CSF), 45  
 Macrophages, 41, 45  
   immune development and, 55  
   IVIG effects on, 149  
   mucosal immunology and, 368, 368f  
 Majeed syndrome, 135t, 139  
 Major basic protein (MBP), 41–42  
 Major histocompatibility complex (MHC)  
   C4 and, 92  
   immunodeficiencies of, 83–84  
 Malaria, immune development and, 57–58  
*Malassezia sympodialis*, 453  
 Malnutrition, complement deficiency and, 98  
 Manganese superoxide dismutase (Hev b 10), 510  
 Mannan binding lectin (MBL), deficiency of, 94  
 Mannan binding lectin associated serine protease 2 (MASP2), deficiency of, 94  
 Mannitol, for exercise-induced asthma, 340  
 MASP2. *see* Mannan binding lectin associated serine protease 2 (MASP2)  
 Mast cell, immunotherapy, 204  
 Mast cell chymase, 439–440  
 Mast cell stabilizers  
   allergic rhinitis and, 217  
   for eye diseases, 495

- Mast cell stabilizing agents (MCSAs), for exercise-induced asthma, 341
- Mast cell tryptase, 174
- Mast cells, 43–44, 43f, 44b
- activation of, 36–39
- allergic rhinitis and, 211
- asthma, 256
- atopic dermatitis and, 415, 441
- degranulation of, 458
- immediate hypersensitivity response and, 167
- immunoglobulin E and, 31, 36
- IVIg effects on, 149
- ocular inflammation, 483t
- oral immunotherapy and, 433
- otitis media, 221
- urticaria/angioedema and, 458
- Mastocytosis, 460–461
- Matched unrelated donor (MUD), 153
- Maternal allergy, 58
- Maternal microbiome, modulation of, 387–389
- Maternal T cell engraftment, SCID and, 85
- Matrix metalloproteinases (MMPs), 257
- Maxwell-Lyon's sign, 488
- MBL. *see* Mannan binding lectin (MBL)
- Mediastinal masses, 245
- Mediator release, IgE production and, 167
- Mediators, in antiviral immune responses, 279
- Medications
- alternative and/or adjunct, asthma, 295–297
  - issues related to delivery of, infants and young children, 297–298
- MEFV* gene, 136
- Membrane attack complex (MAC), deposition of, 150
- Membrane cofactor protein (CD46) deficiency, 96
- Membranoproliferative glomerulonephritis, 93
- Membranous (microfold/M) cells, 365–366, 366f
- Meningococcal disease, complement deficiency and, 90, 96
- Mesenteric lymph nodes (MLNs), 365, 366f, 368
- Metabolic acidosis, asthma, 271
- Methicillin-resistant *Staphylococcus aureus*, 452
- Methotrexate, for juvenile idiopathic arthritis, 118
- Methylprednisolone, for eosinophilic esophagitis, 403
- Mevalonate kinase deficiency (MKD), 134t, 137
- Mevalonic aciduria, 137
- MHC-bound processed peptides, Th differentiation and, 35
- Microbial exposures, 6, 12
- Microbial products, phenotype of, 35–36
- Microbial regulation, of mucosal immunity, 368–369
- Microbicidal disorders, of neutrophil, 102b
- Micronutrients, 425
- Milk allergy, 425–426, 426t–427t
- atopic dermatitis and, 415b, 419t
  - breastfeeding and, 384
  - food labeling, 422
  - gastrointestinal symptoms of, eosinophilic proctocolitis, 405
  - growth and, 423
  - lactose intolerance and, 373, 380
  - micronutrients and, 425
  - natural history of, 390, 418–419
  - sublingual immunotherapy for, 434
- Milk protein allergy
- gastrointestinal symptoms of, 379t
  - in infants, 379t
- Mixed dialkyl thioureas (MDTU), 477
- Modified allergen immunotherapy, 435
- Modified version of the API (mAPI), 286
- Moisturizers, for atopic dermatitis, 448
- Mold
- allergens, environmental control of, 200–201, 201b
  - evaluation of, in indoor environments, 175
- Molecular diagnostics, 69
- Monoclonal antibody, 161, 162t
- Mononuclear phagocytes (MPCs), 59
- Montelukast
- allergic rhinitis and, 217
  - for eosinophilic esophagitis, 403
  - for eosinophilic gastroenteritis, 405
  - skin test reactions and, 179
- Mosquito bites, 513
- Motility disorders, of neutrophil, 102b
- Motivational interviewing, 356–357, 357t
- Mouse allergen, 194
- Mouse ligands, systematic names for, 51t
- Muckle-Wells syndrome (MWS), 134t, 138, 459
- Mucocutaneous candidiasis, 110, 124
- Mucosal immunology, 365–370
- Mucosal mast cell (MMC), 44
- Multi-allergen IgE antibody screening assays, 173
- Multidisciplinary care, for atopic dermatitis, 455
- Multifactorial interventions, for inner city asthma, 308–309
- Multiple drug hypersensitivity syndrome, 504
- Multiple gene defects, 69
- Multiple-headed skin test devices, 181–182, 182f
- Multiple intestinal atresias, combined immunodeficiency with, 87
- Multiplex array for indoor allergens (MARIA), 195
- Münchhausen's syndrome by proxy, 381
- Murmonab-CD3, 160–161
- Muscle pain, familial Mediterranean fever and, 136
- MYB*, 29f
- Mycobacteria, environmental, syndromes with susceptibility to, 108–110, 109f
- Mycobacterium tuberculosis*, 244–245
- Mycophenolate mofetil (MMF)
- for atopic dermatitis, 454
  - for systemic lupus erythematosus, 121
- Mycoplasma pneumoniae* infections, 243
- Myelocytes, 41–48
- Myeloid dendritic cells (mDC), 442
- Myeloid disorders, qualitative, 101
- Myelokathexis, in WHIM syndrome, 102
- Myeloperoxidase deficiency, 107
- Myxovirus resistance protein A (MXA), 58
- N**
- NACDG. *see* North American Contact Dermatitis Group (NACDG)
- NADPH oxidase, 105
- Nail cosmetics, 479
- 'Naked plasmid' DNA, 496
- NALP3 inflammasome, 139, 140f
- Nanotechnology, for food allergy, 436
- Nasal allergen challenges, 177, 183–184
- Nasal polyps on rhinoscopy, 213f
- Nasal products, combination, allergic rhinitis and, 217
- National Asthma Education and Prevention Program (NAEPP) Expert Panel Report 3 (EPR-3), 195, 195b
- guidelines, 289–290, 292f
- National Heart Lung and Blood Institute (NHLBI), 262
- Natural history
- of allergic diseases, 7–17, 389–390, 418–419, 419b
  - of asthma, 313–314
- Natural killer (NK) cells, 48
- asthma, 256–257
  - IL-4 sources, 36
- Natural killer (NK) cells (*Continued*)
- immune development and, 55, 58–59
  - immunodeficiencies, combined, 84
- Natural killer T (NKT) cells, 48
- asthma, 256
  - IL-4 sources, 36
- Natural moisturizing factor (NMF), 448
- Neck, flexural areas of, 471–472
- Nedocromil, 495
- for asthma, in older children, 324–325
- Neisserial infections, complement deficiency and, 90, 95–96
- NEMO mutations, 109
- Neonatal Fc receptor (FcRn), 149
- Neonatal onset multisystem inflammatory disease (NOMID), 134t, 138, 459
- Nephelometry, for complement deficiency, 98
- Nephrotic syndrome, complement deficiencies in, 97
- Neuroinflammatory mechanisms, in viral respiratory infections, 279
- Neuropsychiatric involvement, in systemic lupus erythematosus, 120
- Neutropenia, 78, 101
- alloimmune neonatal, 102–103
  - causes of, 102b
  - cyclic, 102
  - immune-mediated, 102–104
  - severe congenital, 101–102
- Neutrophil disorders, 101, 102b
- therapeutic principles for, 111b
- Neutrophil elastase 2 (*ELA2*), 101
- Neutrophil-specific granule deficiency, 104–105
- Neutrophilia, 101
- causes of, 102b
- Neutrophils, 41, 45–46
- asthma, 253, 256
  - immune development and, 58–59
- Newborn, complement deficiencies in, 97
- NF- $\kappa$ B nuclear-binding activities, IgE isotype switching and, 32
- NHLBI. *see* National Heart Lung and Blood Institute (NHLBI)
- Nickel, as allergen, 477
- Nijmegen breakage syndrome (NBS), 87
- Nitrogen dioxide, 305–306
- NLRP12-associated autoinflammatory disorder, 134t, 138
- NOD2 (*CARD15*), 139
- Non- $\beta$ -lactam antibiotics, allergy to, 502–503
- Non-specific lipid transfer proteins, 169b
- Nonenteral infections, food allergy and, 380
- Nonsteroidal antiinflammatory drugs (NSAIDs)
- allergy to, 503
  - for eosinophilic gastroenteritis, 405
  - for eye diseases, 495
  - for juvenile idiopathic arthritis, 118
  - urticaria/angioedema and, 462
- Normal immunoglobulins, antibody deficiency with, 74
- North American Contact Dermatitis Group (NACDG), 474
- Novel therapeutic targets, for autoimmune diseases, 116
- NSAIDs. *see* Nonsteroidal antiinflammatory drugs (NSAIDs)
- Nucleoside phosphorylase deficiency, 83
- Nutrition, 4–5, 423–425
- complement deficiency and, 98
- O**
- OAS. *see* Oral allergy syndrome (OAS)
- Obesity, 5
- asthma and, 306
  - in older children, 313, 319
  - refractory childhood asthma and, 345

- OIT. *see* Oral immunotherapy (OIT)
- Older children, asthma in, 311–328  
 differential diagnosis of, 314  
 epidemiology and etiology of, 311–313  
 evaluation of, 314–316, 315f  
 factors influencing, 311–313, 312t  
 factors which increase severity of disease,  
 evaluation and management of, 316–319  
 morbidity and mortality, 314  
 natural history of, 313–314  
 persistence and progression into adulthood,  
 313  
 prevalence of, 311  
 treatment of, 321
- Oligoarticular arthritis, 117
- Olopatadine, 494
- OM-85 BV, 300
- Omalizumab (Xolair®), 164, 435–436  
 for asthma, in older children, 325  
 for atopic dermatitis, 456  
 for severe, therapy-resistant asthma, 350  
 skin test reactions and, 179  
 for urticaria/angioedema, 464–465
- Omenn syndrome, 82–83, 82f
- Open-ended questions, 356
- ORAI1, 84
- Oral allergy syndrome (OAS), 378, 409–413  
 characteristics of, 412b  
 clinical manifestations of, 411t  
 diagnosis of, 411, 412b  
 epidemiology of, 409  
 immunotherapy for, 412  
 management of, 412, 412b  
 molecular basis of, 409–410  
 pathogenesis of, 409–410
- Oral corticosteroids, for acute exacerbations of  
 asthma, in young children, 280–281
- Oral immunotherapy (OIT), 430–433, 432t  
 food, 534–535
- Oral mucous membranes, contact allergy of,  
 471
- Oral prednisolone, for severe, therapy-resistant  
 asthma, 350
- Oral tolerance, success of, 384
- Orchitis, familial Mediterranean fever and, 136
- Orencia®, 162
- Organic dust antigens, 174
- ORMDL3, 23, 29f
- Osmotic hypothesis, exercise-induced asthma,  
 337
- Otitis media, 219–227, 227b  
 acute, 221–222, 222t, 224–226, 225f  
 chronic, with effusion, 222–223, 223f–224f  
 classification of, 220b  
 definitions of, 219  
 diagnosis of, 222–224  
 diagnostic techniques in, 223–224  
 with effusion, 221–222, 226  
 mediators of allergy, 222  
 epidemiology of, 219–220  
 etiology of, 221–222  
 mediators of allergy and, 222  
 pathogenesis of, 221  
 pathophysiology of, 220–221  
 recurrent, 63  
 risk factors for, 220b  
 structure and function of, 220  
 treatment of, 224–226
- Otoscopy, pneumatic, 224
- Outdoor aeroallergens, 173
- Outdoor allergens, 185–190  
 climate change on, 190  
 environmental control, 201  
 meteorological variables in, 189–190  
 sampling, 187, 188f  
 sources and types, 186t
- Outdoor environmental exposures, 306
- Overweight children  
 asthma, 313  
 definition of, 424
- Oxidative metabolism, defects of, 105–110
- Oximetry, 273
- Oxygen tension, asthma, 270–271, 270f
- P**
- P. jirovecii* pneumonia (PIP), 86
- p-Phenylenediamine (PPD), 467
- p56lck deficiency, 83
- Package label, of food, 422
- PAL. *see* Persistent airflow limitation (PAL)
- Palivizumab (Synagis®), 164
- Panuveitis, 489
- Papillae, 486t
- Paranasal sinuses, computed tomography of,  
 229f
- Parental supervision, refractory asthma, 346
- Paroxysmal nocturnal hemoglobinuria (PNH),  
 complement deficiency and, 98
- Particulate matter (PM), 305
- 'Partly controlled' asthma, 290–291
- Partnership, 356, 357b
- Parvalbumin, 169b
- Patatin-like protein (Hev b 7), 509
- Patch testing, 414, 504  
 in contact dermatitis, 473–477, 473t  
 appropriate subjects to test on, selection of,  
 473  
 procedure for, 474–476  
 recommendations for, 476t  
 relevance of, 476t
- Pathogen-associated molecular patterns (PAMPs),  
 112, 255
- Pathogenesis related protein (PR10 family), 168,  
 169b
- Patient behavior, strategies to change, 355
- Patient-centered care, 355–357, 356b
- Pattern recognition receptors (PRRs)  
 asthma, 255  
 atopic dermatitis and, 440
- Pauciartthritis, 117
- Peak flow meters, 269
- Peanut, food labeling, 422
- Peanut allergy, 428  
 atopic dermatitis and, 415b, 419t  
 natural history of, 390, 418–419  
 prevalence of, 386  
 sublingual immunotherapy for, 434
- Pediatric granulomatous arthritis, 139
- Pemirolast, 495
- Percutaneous test  
 devices for, 181–182, 182f  
 diagnostic usefulness of, 180
- Perennial allergic conjunctivitis, 487–488
- Perennial allergic rhinitis, 212
- Pericarditis, systemic lupus erythematosus and, 120
- Periodic fevers, aphthous stomatitis, pharyngitis  
 and adenitis (PFAPA), 135t, 137, 140
- Periodicity, autoinflammatory disorders and, 133
- Perioral dermatitis, 471
- Peripheral blood smear, examination of, 66–67
- Persistent airflow limitation (PAL)  
 assessment of, 349–350  
 bronchodilator responsiveness, 346  
 'Persistent wheezers', 285–286
- Personal hygiene product, 478
- Pertussis, 243
- Pet allergens, 193–194  
 clinical significance of, 193–194
- Pet ownership, 12–13
- Peyer's patches (PPs), 365, 366f
- pH, arterial values of, 271
- Phagocytic cells, evaluation of, 68–69
- Phagocytosis disorders, 102b
- Pharmacogenetics, 27
- PHF11, 29f
- Phlyctenules, 486t, 490
- Phototherapy, for atopic dermatitis, 453
- Phox proteins, 105
- Phthirus pubis*, 490
- Physical activity, asthma and, 330
- Physical examination, asthma, in older children,  
 315
- Physical methods, for severe, therapy-resistant  
 asthma, 351
- Phytoproteroses, 478
- PI3K- $\delta$  mutations, immunodeficiency due to, 84
- Pimecrolimus cream, 450–451
- Placebo effect, 203
- Plant dermatitis, 478
- Plasmacytoid dendritic cells (PDCs), 254,  
 442–443
- Plasmapheresis, for rheumatologic diseases,  
 115–116
- Pleuritis, familial Mediterranean fever and, 136
- Pluripotent stem cells, induced, 158–159
- Pneumatic otoscopy, 224
- Pneumonia  
 asthma, 245  
 recurrent, 63  
 hyper-IgE syndrome and, 110
- Pneumonitis, hypersensitivity, 174
- Point of maximal inspiration, 269f
- Polistes* allergens, 174, 515f
- Pollen, 168, 185  
 climate change in, 190  
 extracts, skin test reactions to, 179  
 representative, 187–189, 189f
- Pollen-food allergy syndrome, 372
- Pollen-food associations, 410–411, 410t
- Pollution, air, indoor, 201
- Polyarthritides, 117
- Polymeric Ig receptor (pIgR), mucosal  
 immunology and, 370
- Polysaccharide antibody, 75–76
- Polyunsaturated fatty acids (PUFA), 386–387
- Positional cloning, gene identification and, 21–22
- Postnasal drip, 245
- Prebiotics, 388–389
- Precipitin assays, 174
- Prednisolone, oral, for severe, therapy-resistant  
 asthma, 350
- Prednisone  
 for atopic dermatitis, 453–454  
 for chronic granulomatous disease, 105–106  
 for systemic lupus erythematosus, 121
- Pregnancy  
 allergy-protective influences, 13  
 allergy risk factors, 4  
 immune development and, 54–55, 57
- Preschool children, virus-induced wheezing in,  
 280
- Preservatives, allergy to, 478, 479t
- Pressure equalization (PE) tubes, 226
- Pressurized metered dose inhaler (pMDI),  
 297–298
- Prevention, immunotherapy as, 209
- Prick skin test, 177–178, 180
- Primary autoimmune neutropenia, 104
- Primary ciliary dyskinesia (PCD), 65
- Primary Immune Deficiency Treatment  
 Consortium (PIDTC), 153
- Primary immunodeficiency, patterns of illness  
 associated with, 66t
- Proactive therapy, for atopic dermatitis, 451
- Probiotics, 16, 259, 388  
 for atopic dermatitis, 456
- Procalcitonin, 169b

- Proctocolitis  
 dietary protein, 392, 394–396, 396*t*, 398*b*  
 eosinophilic, 405–406  
 clinical manifestations of, 405–406  
 diagnosis of, 406  
 etiology of, 405  
 evaluation of, 406  
*versus* FPIES, 406*t*  
 management of, 406  
 food protein-induced, 378  
 Profilin, 169*b*, 409, 510  
 Prohevein (Hev b 6), 509  
 Properdin deficiency, 96  
 Proptosis, 486*t*  
 Prostaglandin E<sub>2</sub>, in inflammatory response, 113  
 Protein contact dermatitis, 469  
 Protein hydrolysate formula, 394–396, 406  
 Protein-induced enterocolitis, 378, 394  
 Protein-induced enteropathy, 394  
 Protein-induced proctocolitis, 378, 394  
 Protein kinase C delta deficiency, 131  
 Protein kinase inhibitors, for autoimmune diseases, 116  
 Proteins  
 antigenic, after birth, 384  
 need for, 424, 425*t*  
 Proteasome associated autoinflammatory syndromes (PRAAS), 135*t*, 141  
 Provider targeted interventions, for inner city asthma, 307–308  
 Pruritus, control of, 453  
 PSTPIP1, 139  
 Psychogenic cough, 247  
 Psychological factors, asthma, in older children, 318  
 Psychological reactions, to food, 373  
 Psychosocial factors, asthma, 305  
 Psychosocial issues, refractory asthma and, 347  
 Ptosis, 486*t*  
 Pulmonary function  
 IVIG in, 144  
 tests for asthma in older children, 314, 316  
 Pulmonary inflammation, role of cell trafficking and migration in, 257  
 Puncture testing, 180  
 Pyogenic sterile arthritis, pyoderma gangrenosum and acne (PAPA), 134*t*, 139–140  
 Pyrin protein, familial Mediterranean fever and, 136
- Q**  
 Quick reliever medications, for asthma, 325–326
- R**  
 RAC2 gene, mutations in, 108  
 Radioallergosorbent test (RAST), 170  
 Radiographic imaging, sinusitis, 232  
 Radiology, asthma, in older children, 315–316  
 RAG1, 82  
 RAG2, 82  
 Ragweed-melon-banana association, 410, 410*t*  
 Ragweed pollen, 204*f*  
 RANTES (regulated upon activation normal T cell-expressed and secreted), 52, 222  
 RAS associated autoimmunity lymphoproliferative disorder, 131  
 Rash  
 familial Mediterranean fever and, 136  
 in juvenile dermatomyositis, 122, 122*f*  
 in systemic lupus erythematosus, 119, 119*f*  
 in systemic onset juvenile idiopathic arthritis, 117, 118*f*  
 Rat allergen, measurement of, 174–175  
 Raxibacumab, 164–165  
 Recent thymic emigrants (RTE), 56  
 Recombinant allergen immunotherapy, 435  
 Recurrent infections  
 approach to child with, 63–70, 69*b*  
 clinical presentation of, 63–66  
 definition of, 63, 64*b*  
 laboratory tests for, 66–69  
 Recurrent respiratory tract bacterial infections, differential diagnosis of, 75*b*  
 Red fire ants, 515  
 venom of, allergy to, natural history of, 519  
 Reflective listening, 356, 357*t*  
 Refractory anaphylaxis, 530  
 Regulatory T cells, asthma, 253–254  
 different mechanisms, 259*f*  
 Relationship, building, 355–356, 356*b*  
 Renal failure, from IVIG treatment, 147–148  
 Repeat open application test (ROAT), 477  
 Rescue therapy, school asthma care plans and, 330  
 Respiratory alkalosis, 270–271  
 Respiratory diseases  
 environmental risk factors and, 4  
 hypersensitivity pneumonitis, 247  
 Respiratory infections  
 asthma and, 11–12  
 chronic cough and after, 242–245  
 environmental risk factors for, 5  
 immune development and, 57–58  
 otitis media, 219  
 Respiratory syncytial virus (RSV)  
 allergy skin testing and, 178  
 asthma and, 11, 242, 258  
 chronic cough, 242  
 Respiratory tract, hereditary angioedema in, 95  
 Respiratory tract infections, autoimmune neutropenia and, 104  
 Reticular dysgenesis, 80, 85, 102  
 Retina, chronic granulomatous disease and, 106  
 Retinoic acid, 367–369  
 Retroviral vectors, for gene therapy, 157  
 Rheumatic diseases of childhood, therapeutic principles for, 112–123  
 Rheumatology, definition of, 112–123  
 Rhinitis  
 asthma and, 317  
 causes of, 212*b*  
 defined, 210  
 infectious, 212  
 Rhinosinusitis  
 definition of, 228  
 refractory childhood asthma and, 345  
 Rhinovirus infection  
 asthma and, 11–12, 258  
 pathogenesis of, 221  
 Rilonacept (Arcalyst®), 138, 165  
 RNA, IgE isotype switching and, 32, 33*f*  
 Rodent allergens, environmental control of, 200, 200*b*  
 Rosacea, ocular, 490  
 Rotorod aeroallergen samplers, 187, 188*f*  
 Rubber chemicals, as allergens, 472, 477  
 Rubber elongation factor (Hev b 1), 508  
 Rubber elongation factor (REF) homolog (Hev b 3), 508–509  
 Rubber hydrocarbon, 508  
 Rural populations, 2–3
- S**  
 Saline, allergic rhinitis and, 217  
 Salmeterol, in infants and young children, 296  
 Sarcoidosis, 489  
 Schimke syndrome, 87  
 School-based interventions, for inner city asthma, 307  
 School-centered programs, for asthma, 329–335, 334*b*  
 asthma care providers, in community, 334, 335*t*  
 asthma friendly schools, 332–333, 333*t*  
 evaluated strategies, 331  
 information technology infrastructure, 331–332  
 management and treatment  
 case management and care coordination, 331  
 challenges in schools, 330  
 communication and, 330  
 cost-effectiveness of strategies, 333–334  
 directly observed therapy, 331  
 physical activity, 330  
 self-management skills, 332  
 rescue therapy and, 330  
 School health team, human resource supplementation of, 331  
 School visit, refractory asthma and, 347  
 SCID. *see* Severe combined immunodeficiency (SCID)  
 SCIG. *see* Subcutaneous immunoglobulin (SCIG)  
 Scleritis, 486*t*  
 Scratch test, 180  
 Seasonal allergic conjunctivitis, 487  
 Seasonal allergic rhinitis, 212  
 Second signals, for isotype switch recombination, 34  
 Secondary antibody deficiency, 75  
 Secondary autoimmune neutropenia, 104  
 Secondary immunodeficiency, 66  
 Segregation analysis, genetics, 19  
 Self-management skills, for asthma, 332  
 Sepsis, complement deficiency and, 97  
 Serological tests, for human allergic disease, 172, 172*b*  
 ‘Seropositive’ arthritis, 117  
 SERPING1 gene, 459  
 Serum albumin, 169*b*  
 Serum markers, of hypersensitivity pneumonitis, 174  
 Serum sickness, complement deficiency and, 97  
 Serum specific IgE levels (sIgEs), in oral allergy syndrome, 411  
 Severe Asthma Research Program (SARP), lessons from, 352  
 Severe asthma with fungal sensitization (SAFS), 345, 346*t*  
 criteria for, 350  
 Severe combined immunodeficiency (SCID), 80–86, 81*t*, 152–154  
 differential diagnosis of, 85, 85*b*, 85*f*  
 evaluation and management of, 85–86  
 gene therapy for, 155–156  
 genetic causes of, 153*b*  
 HSCT for, 153*b*  
 infants with, 153, 154*b*  
 reticular dysgenesis, 80, 85  
 treatment of, 86, 86*b*  
 X-linked, 156  
 Severe congenital neutropenia (SCN), 101–102  
 Sex differences  
 allergic rhinitis, 210  
 classification of, 211–212  
 ‘Shared-care approach’, 289  
 Shared decision-making model, 357–358  
 Shellfish allergy  
 food labeling, 422  
 natural history of, 390, 418–419  
 Short-acting  $\beta$ -agonists (SABAs)  
 for exercise-induced asthma, 340  
 pharmacogenetics and, 27  
 Sib pairs analysis, genetics and, 20  
 Sickle cell disease (SCD), IVIG and, 150  
 Signal transducer and activator of transcription (STAT), 125–126  
 Simulect®, 163



- Single-dose blind food challenges, 376
- Single-nucleotide polymorphisms (SNPs), 20  
 candidate gene studies and, 24–25, 25f  
 genome-wide association studies, 21
- Sinopulmonary infections, recurrent, 64
- Sinus development, 228
- Sinus ostia, anatomic obstructions of, 229
- Sinusitis, 228–237  
 adjunctive medical therapy in, 237  
 adjunctive surgical procedures in, 237  
 allergic fungal, 232  
 allergy risk factors of, 232  
 antimicrobials in, 234b  
 asthma and, 232, 317  
 chronic cough, 238–249  
 chronic rhinosinusitis in young children, 232  
 clinical definitions of, 228  
 complications, 234, 234f  
 surgery for, 236–237  
 and cystic fibrosis, 232  
 differential diagnosis and risk factors for, 233b  
 epidemiology of, 228–229  
 etiology of, 229–232  
 genetic risk factors of, 232  
 immune pathogenesis of, 231–232  
 management of, 232–234  
 microbial pathogenesis of, 229–231  
 pathogenesis of, 228  
 radiographic imaging of, 233  
 recurrent, 63, 228  
 treatment, 234–237
- Skeeter syndrome, 513
- Skin  
 barrier function of, 29f, 439, 448–449  
 immunopathology, 441–442  
 juvenile dermatomyositis and, 122  
 systemic lupus erythematosus and, 118–119
- Skin diseases  
 dermatitis herpetiformis, 394  
 IPEX syndrome, 414–415
- Skin tests, 170–171, 172b, 184b  
 allergic rhinitis and, 214  
 for anaphylaxis, 533  
 asthma and, 177  
 bronchial allergen challenge and, 184  
 delayed reactions to, 183  
 for drug allergy, 500  
 in children, 500  
 general aspects of, 500  
 expressing results of, 181, 181t  
 factors affecting size and prevalence of positive, 177–180  
 age as, 177–178  
 medication as, 179, 179t  
 physiologic, 178  
 quantity and quality of extracts as, 179–180  
 skin reactivity as, 178  
 viral infections as, 178  
 for food allergy, 373–374  
 for latex allergy, 510  
 for local allergy, 182–183  
 methods of, 180–182  
 nasal allergen challenge and, 183–184  
 for oral allergy syndrome, 411  
 oral immunotherapy and, 433  
 prevalence of positive, 177  
 rhinitis and, 177  
 safety of, 182  
 special considerations for, 182–184  
 on venom, insect sting allergy, 519  
 in vitro measurements of IgE and, 183
- SLE. *see* Systemic lupus erythematosus (SLE)
- Sleep disordered breathing, refractory childhood  
 asthma and, 345
- SMART regimen, 350  
 for severe, therapy-resistant asthma, 350
- Smoking  
 environmental tobacco smoke and, 4  
 asthma and, 4, 9, 12, 305, 317–318  
 genetics and, 25, 28, 29f  
 otitis media, 219–220
- Socioeconomic impact, allergic rhinitis and, 211
- Socioeconomic status, asthma and, 303  
 in older children, 311
- Sodium hypochlorite, 448, 452
- Solar urticaria, 461t
- Soliris®, 164
- Soy formula, 407, 426
- Soybean allergy, 427–428  
 atopic dermatitis and, 419t  
 food labeling, 422
- Specific antibody deficiency with normal immunoglobulins' (SADNI), 74
- SPINK5* gene, 414–415, 439–440
- Spirometry, 268, 316, 346
- Spitting up, food allergy and, 380
- Spleen, 483  
 immune development of, 54
- Staphylococcus aureus*  
 atopic dermatitis and, 444–445, 444f, 452, 452f  
 blepharitis and, 489
- STAT-6  
 allergic asthma, 252  
 IgE isotype switching and, 32
- STAT1 gain of function (STAT1-GOF) mutations, 125–127, 126b
- STAT5B deficiency, 84, 127–128, 128b
- Stem cell factor (SCF), 43–44
- Stem cell therapy, for antibody deficiency, 78
- Stem cells, gene therapy using, 155–159, 155f
- 'Step-up, step-down' approach, in NAEPP guidelines, 290
- Steroid responsiveness  
 assessment of, 349  
 domains and definition of, 349t
- Steroids  
 for eosinophilic gastroenteritis, 405  
 pharmacogenetics and, 27  
 resistance to, 27, 255  
 skin test reactions and, 179  
 for systemic lupus erythematosus, 121
- Still's disease, 117
- Sting associated vasculopathy with onset in infancy (SAVI), 135t, 141
- Sting challenge tests, for venom-specific IgE, 520
- Stinging insect  
 immunotherapy, 206  
 venom immunotherapy, 206
- Storage proteins, 169b
- Stress, asthma and, in older children, 312–313
- Stressors, emotional, atopic dermatitis and, 452
- Structural database of allergenic proteins (SDAP), 168
- Subacute sinusitis  
 antibiotics for, 235t  
 antimicrobial therapy in, 234–236  
 microbiology of, 229–230, 230t
- Subcutaneous immunoglobulin (SCIG), 143  
 administration of, 146–147  
*versus* IVIG, 146  
 reactions to, 148
- Sublingual immunotherapy (SLIT), 203, 206, 208–209, 432t, 433–434
- Subtotal C6 deficiency (C6SD), 93
- Sulfonamides, allergy to, 502
- Sulfur heat vulcanization, 507
- Summary statements, 356–357
- Sunscreens, 479
- Superantigens, staphylococcal, 444
- Support systems, for medical care, in asthma, 362–363
- Surgery  
 latex allergy in, 506  
 sinusitis, 236–237
- Sustained unresponsiveness, definition of, 430
- Swimmers, 479
- Synagis®, 164
- Syndrome complexes, 65–66
- Systemic antihistamines, for atopic dermatitis, 453
- Systemic autoimmune disorders, complement deficiency and, 90–91
- Systemic contact dermatitis, 472–473, 473t
- Systemic corticosteroids, for asthma, 299  
 in older children, 326
- Systemic immunosuppression, for rheumatologic diseases, 115–116
- Systemic inflammation, assessing, 113–114
- Systemic lupus erythematosus (SLE), 118–121  
 complement deficiency and, 90, 97, 99  
 diagnosis of, 119–120, 119b, 119f  
 laboratory assessment of, 120–121  
 musculoskeletal symptoms of, 119  
 prognosis of, 121  
 treatment of, 121
- Systemic onset juvenile idiopathic arthritis, 117
- T**
- T<sub>B</sub> SCID, 82
- T cell epitopes, immunotherapy, 208
- T cell immunodeficiencies, 80–89  
 adenosine deaminase, 80, 85  
 ataxia-telangiectasia, 87  
 bone marrow transplantation, 87  
 intravenous immunoglobulins, 86  
 SCID. *see* Severe combined immunodeficiency (SCID)  
 Wiskott-Aldrich syndrome, 87–88
- T cell receptor excision circles (TRECs), 56
- $\gamma\delta$  T cell receptors, 257
- T cell subsets, asthma, 253–255
- T cells, 47, 48b  
 atopic dermatitis and, 414–415, 440  
 autoimmune lymphoproliferative syndrome and, 128  
 depletion of, in HSCT, 153b  
 effector, in contact dermatitis, 469  
 food allergy and, 384  
 atopic dermatitis, 414–415  
 celiac disease, 394  
 eosinophilic esophagitis, 400  
 mucosal immunology, 365–367, 366f  
 functional phenotype of, 56–58  
 $\gamma\delta$  type, 48  
 helper cell differentiation, 35, 35f
- IgE  
 allergen-specific responses, 35–36  
 isotype switching and, 33  
 immune development and, 54, 58–59  
 immunotherapy effects on, 204  
 modulation of, 52  
 recruitment of, in allergic contact dermatitis, 468–469  
 regulatory  
 asthma, 253–255, 259f  
 in contact dermatitis, 469  
 surface phenotype of, 56  
 tolerance, 367
- T-helper 1 (Th1) cells  
 allergen specificity of, 8–9, 35  
 atopic dermatitis and, 440, 442  
 contact dermatitis and, 468  
 differentiation of, 35, 46  
 genetic predispositions to, 35  
 immune development of, 7–8  
 paradigm, 252–253

- T-helper 2 (Th2) cells  
 allergen specificity of, 8–9, 35  
 allergic rhinitis and, 211  
 asthma, 250–252  
   response, 252, 253*f*  
 atopic dermatitis and, 440, 442  
 contact dermatitis and, 469  
 differentiation of, 35, 46  
 genetic predisposition to, 35  
 immune development of, 7–8  
 paradigm, 252–253
- T-helper 3 (Th3) cells, 367
- T-helper 9 (Th9) cells, asthma, 255
- T-helper 17 (Th17) cells, 35, 58  
 asthma, 254–255  
 atopic dermatitis and, 443  
 role of, in allergic rhinitis, 211
- T-helper 22 (Th22) cells, asthma, 255
- T-helper (Th) cells  
 differentiation of, 46  
 immunotherapy, 204
- T regulatory cells (T<sub>REG</sub> cells), 35  
 from APECED, 124  
 asthma and, 258–259  
 atopic dermatitis and, 441  
 IVIG on, 150–151
- Tacrolimus ointment, 450–451
- Tar preparations, for atopic dermatitis, 453
- TCR signaling, defects of, 83
- TCR $\alpha$  constant chain (TRAC) gene defect, 83
- Tear film, 483
- Technology-based interventions, for inner city asthma, 308
- Tennis players, 479–480
- Terbutaline, subcutaneous infusions, for severe, therapy-resistant asthma, 351
- Test for Respiratory and Asthma Control in Kids (TRACK), 292–294
- TGF- $\beta$ , mucosal immunology and, 367–368
- Th2-mediated eosinophilic inflammation, 231–232
- 'The Creating Asthma Friendly Schools Resource Kit', 333
- Theophylline  
 for asthma, in older children, 325  
 low-dose, for severe, therapy-resistant asthma, 350
- Therapy, for inner city asthma, 306, 307*f*
- Therapy-resistant asthma, severe, 345–348  
 annual assessment of, 352  
 characteristics of, 348*t*  
 distinction between 'difficult asthma' and, 348  
 genetics, 352  
 invasive testing for, 348–350, 348*t*  
   protocol for, 348–350  
 monitoring of, 351–352  
   benefit, 351  
   side-effects, 351–352  
 pathophysiology of, 352  
 treatment for, 350–351  
   planning of, 352–353  
 viral infections, response to, 352  
 vitamin D for, 352
- Thermal hypothesis, exercise-induced asthma, 337
- Thimerosal, as allergen, 477
- Thin-layer rapid use epicutaneous test (T.R.U.E test), 474, 475*t*
- Thioureas, 477
- Thommen's postulates, 186, 186*b*
- Thrombosis, IVIG-related, 148
- Thymic medullary epithelial cells (mTEC), 124
- Thymic stromal lymphopoietin (TSLP), 256
- Thymus  
 DiGeorge syndrome and, 86–87  
 immune development of, 54, 56
- Thyroid, function of, urticaria/angioedema and, 459
- Tissue response genes, 29*f*
- TNF receptor-associated periodic fever syndrome (TRAPS), 135*t*, 137
- TNF receptor family, IgE and, 33
- TNFRSF1A gene, 137
- Tocilizumab (Actemra®), 165
- Tofacitinib, for rheumatoid arthritis, 116
- Tolerance  
 allergen, 255  
 definition of, 430  
 immune, asthma, 253–254, 258–259  
 mucosal immunology and, 367–368
- Toll-like receptors (TLRs)  
 atopic dermatitis and, 440  
 immune development and, 58  
 mucosal immunology and, 369
- Topical calcineurin inhibitors, for allergic contact dermatitis, 480
- Topical corticosteroids  
 for contact dermatitis, 480  
 for eye diseases, 496
- Topical medications, dermatitis from, 478
- Toxic epidermal necrolysis (TEN), 150
- Toxic reactions, to food, 373
- Toxicodendron* group, allergic plant dermatitis and, 478
- Tracheal stenosis, 246
- Tracheobronchomalacia, 245
- Traditional Chinese medicine, 436
- Transient hypogammaglobulinemia of infancy (THI), 74
- 'Transient wheezers', 285–286
- Transmission/disequilibrium test (TDT), 20–21
- Trantas' dots, 486*t*, 488
- Treatment plan, collaboration on, 357–358
- Tree nut allergy  
 atopic dermatitis and, 418–419  
 food labeling, 422  
 natural history of, 390, 418–419
- Tree pollen, 168, 188–189
- Triamcinolone, intramuscular, for severe, therapy-resistant asthma, 350
- Trichiasis, 486*t*
- Trichuris suis* egg therapy, 436
- Trimethoprim-sulfamethoxazole  
 for chronic granulomatous disease, 105  
 for SCID, 86
- Tropomyosin, 169*b*
- Tryptase  
 mast cell, 174, 527  
 for venom-specific IgE, 520
- Tucson Children's Respiratory Study (CRS), 7, 9, 11–12
- Twin studies, 19, 22
- Tyk2 deficiency, 110
- Tympanometry, 224
- Tympanostomy tubes, 226
- U**
- 'Uncontrolled' asthma, 290–291
- Upper airway obstruction, refractory childhood asthma and, 345
- Urban populations, 2–3
- Urinalysis, for lupus nephritis, 120
- Urticaria, 458–466  
 acute, 460  
 chronic, 460–462  
 definition of, 458, 459*f*  
 diagnostic procedures for, 463, 463*b*  
 differential diagnosis for, 459–462, 460*f*  
 epidemiology of, 458  
 etiology of, 458–459  
 evaluation of, 462–463  
 history of, 462–463  
 key concepts in, 459*b*  
 major syndromes, 461*t*
- Urticaria (*Continued*)  
 management of, 462–463  
 physical examination of, 463  
 treatment of, 464*b*
- Urticarial vasculitis, 461–462
- USA, allergens in, food labeling and, 421*t*
- UVB therapy, for atopic dermatitis, 453
- Uveal tract, 483
- Uveitis, 117, 489
- V**
- Vaccines/vaccinations  
 allergy to, 503–504  
 diagnosis and management of, 504  
 atopic dermatitis and, 453  
 for DiGeorge syndrome, 87  
 systemic reaction to, management of, 504
- Valacyclovir, 452–453
- Variable/diversity/joining (VDJ) recombination, 82
- Vascular rings, 245
- Vasculitis, urticarial, 461–462
- Vasocon-A, 493
- VDJ recombination, 82
- Venom immunotherapy, 206, 520–523  
 dosing schedule in, 521–522, 522*t*  
 duration of, 523  
 indications for, 521, 521*t*  
 inefficacy of, risk factors for, 523*b*  
 optimizing, 174  
 results of, 522–523  
 side effects of, 522, 522*b*  
 venom selection in, 521
- Ventilation tubes, 226
- Vernal conjunctivitis, 487, 487*f*
- Vernal keratoconjunctivitis, 488  
 conjunctival hyperemia with papillary hypertrophy in, 488*f*
- Vespidae, 514–515
- Vespula, 514, 515*f*
- Viaskin™ device, 435
- VIPES trial, 435
- Viral infections  
 allergic disease and, 9, 12  
 allergy skin testing and, 178  
 atopic dermatitis and, 445, 452–453  
 chronic cough and, 238  
 epidemiology of allergic disease, 5  
 immune development and, 56–58  
 neutrophil disorders and, 101  
 respiratory, asthma and, in older children, 313  
 severe therapy-resistant asthma and, 352  
 sinusitis and, 229
- Virus-induced wheezing  
 in infancy, 280  
 leukotrienes modifiers for, 282  
 in preschool children, 280  
 proposed mechanisms of, 278*b*
- Vitamin D  
 for allergy and asthma prevention, 313  
 asthma- and allergy-protective influences, 13  
 for atopic dermatitis, 456  
 for food allergy, 387  
 milk allergy and, 426  
 for severe, therapy-resistant asthma, 352
- Vocal cord dysfunction (VCD)  
 asthma and  
   functional assessment, 272  
   in older children, 316, 318  
 chronic cough, 247
- Vomiting, food allergy and, 380–381
- W**
- Warts, in WHIM syndrome, 102
- WAS. *see* Wiskott-Aldrich syndrome (WAS)

- Wasps, 174, 515  
 Water supply, 4  
*WDR36*, 29*f*  
 Weed pollens, 189  
 Weight  
   asthma and, 5  
   food allergy and, 424  
 Weight gain, asthma from, 5  
 Weightlifters, 480  
 ‘Well-controlled’ asthma, 290–291  
 Western countries, 1–2  
 Wet wrap therapy, 454–455, 455*f*  
 Wheat allergy, 427, 428*t*  
   atopic dermatitis and, 419*t*  
   natural history of, 418–419  
 Wheezing  
   chronic cough and, 243  
   differential diagnosis of, 272  
   in infants and young children, 286  
   infection-induced, 278–279, 278*b*  
   in infancy, 280  
   in preschool children, 280  
   treatment of, 280–283
- Wheezing (*Continued*)  
   phenotypes, 286  
   predicting persistent asthma, 285–286  
 WHIM (warts, hypogammaglobulinemia, infections and myelokathexis) syndrome, 102  
 White blood cell, defects of, 111*b*  
   infections and, 103*t*  
   therapeutic principles for, 111*b*  
 Whooping cough, 244  
 Wind-pollinated plants, characteristics of, 185–186, 186*b*  
 Wiskott-Aldrich syndrome (WAS), 65*t*, 87–88, 88*f*, 154  
   gene therapy for, 157  
 Wiskott-Aldrich syndrome protein (WASP), 102  
 World Health Organization (WHO) growth charts, 423
- X**  
 X-linked agammaglobulinemia (XLA), 71–72, 144
- X-linked autoimmune and allergic dysregulation syndrome (XLAAD), 253–254  
 X-linked lymphoproliferative disease (XLP), 73  
 X-linked recessive trait, inherited complement deficiencies and, 91  
 X-linked severe combined immune deficiency, 80–82  
   gene therapy for, 156  
 X-linked severe congenital neutropenia (XLN), 102  
 Xgeva®, 163  
 Xolair®, 164
- Y**  
 Yellow jacket, 174, 514  
   stinger of, 515*f*
- Z**  
 ZAP-70 deficiency, 83  
 Zinc-finger nucleases (ZFNs), 158  
 Zinc-finger transcription factor, 32