

The Complete CFO Handbook

From Accounting to Accountability

FRANK J. FABOZZI
PAMELA PETERSON DRAKE
RALPH S. POLIMENI



John Wiley & Sons, Inc.

The Complete CFO Handbook

The Complete CFO Handbook

From Accounting to Accountability

FRANK J. FABOZZI
PAMELA PETERSON DRAKE
RALPH S. POLIMENI



John Wiley & Sons, Inc.

Copyright © 2008 by John Wiley & Sons, Inc. All rights reserved.

Published by John Wiley & Sons, Inc., Hoboken, New Jersey.
Published simultaneously in Canada.

Wiley Bicentennial Logo: Richard J. Pacifico

No part of this publication may be reproduced, stored in a retrieval system, or transmitted in any form or by any means, electronic, mechanical, photocopying, recording, scanning, or otherwise, except as permitted under Section 107 or 108 of the 1976 United States Copyright Act, without either the prior written permission of the Publisher, or authorization through payment of the appropriate per-copy fee to the Copyright Clearance Center, Inc., 222 Rosewood Drive, Danvers, MA 01923, (978) 750-8400, fax (978) 646-8600, or on the web at www.copyright.com. Requests to the Publisher for permission should be addressed to the Permissions Department, John Wiley & Sons, Inc., 111 River Street, Hoboken, NJ 07030, (201) 748-6011, fax (201) 748-6008, or online at <http://www.wiley.com/go/permissions>.

Limit of Liability/Disclaimer of Warranty: While the publisher and author have used their best efforts in preparing this book, they make no representations or warranties with respect to the accuracy or completeness of the contents of this book and specifically disclaim any implied warranties of merchantability or fitness for a particular purpose. No warranty may be created or extended by sales representatives or written sales materials. The advice and strategies contained herein may not be suitable for your situation. You should consult with a professional where appropriate. Neither the publisher nor author shall be liable for any loss of profit or any other commercial damages, including but not limited to special, incidental, consequential, or other damages.

For general information on our other products and services or for technical support, please contact our Customer Care Department within the United States at (800) 762-2974, outside the United States at (317) 572-3993, or fax (317) 572-4002.

Wiley also publishes its books in a variety of electronic formats. Some content that appears in print may not be available in electronic books. For more information about Wiley products, visit our web site at www.wiley.com.

Note: The previous edition of this work is titled *Cost Accounting: Concepts and Applications for Managerial Decision Making*, third edition.

Library of Congress Cataloging-in-Publication Data

Fabozzi, Frank J.

The complete CFO handbook : from accounting to accountability / Frank

J. Fabozzi, Pamela P. Peterson Drake, Ralph S. Polimeni.

p. cm.

Includes index.

ISBN 978-0-470-09926-1 (cloth)

1. Chief financial officers—Handbooks, manuals, etc. 2.

Corporations—United States—Finance—Handbooks, manuals, etc. I.

Peterson Drake, Pamela, 1954- II. Polimeni, Ralph S. III. Title.

HG4027.35.F33 2007

658.15'1--dc22

2007018191

Printed in the United States of America.

10 9 8 7 6 5 4 3 2 1

FJF

To my wife, Donna, and my children,
Karly, Patricia, and Francesco

PPD

To my husband, Randy

RSP

To my inspiration, Maxine Elko

Contents

| | |
|---|------------|
| Preface | xv |
| About the Authors | xix |
| CHAPTER 1 | |
| The Changing Role of the CFO: From Accounting to Accountable | 1 |
| SOX Act of 2002 and the CFO | 2 |
| Expanded Responsibilities of the CFO | 6 |
| Our Agenda | 14 |
| PART ONE | |
| Funding | 15 |
| CHAPTER 2 | |
| Capital Structure Decisions | 17 |
| Debt versus Equity | 18 |
| Concept of Leverage | 21 |
| Capital Structure and Financial Leverage | 25 |
| Financial Leverage and Risk | 29 |
| Capital Structure and Taxes | 31 |
| Capital Structure and Financial Distress | 37 |
| Cost of Capital | 41 |
| Agency Relationship | 43 |
| Optimal Capital Structure: Theory and Practice | 47 |
| A Capital Structure Prescription | 51 |
| Bottom Line | 52 |
| Appendix: Capital Structure Theory—The Modigliani-Miller Theory and Beyond | 53 |
| CHAPTER 3 | |
| Types of Debt Financing | 63 |
| General Features of Debt Obligations | 64 |

| | |
|--|------------|
| Term Loans | 65 |
| Syndicated Bank Loans | 69 |
| Notes and Bonds | 71 |
| Short-Term Financing | 86 |
| Off-Balance-Sheet Financing | 93 |
| Bottom Line | 95 |
| CHAPTER 4 | |
| Equity Funding | 99 |
| Common Stock | 100 |
| Preferred Stock | 115 |
| Bottom Line | 121 |
| CHAPTER 5 | |
| Structured Financing: Asset Securitization and Structured Notes | 123 |
| Asset Securitization | 124 |
| Structured Notes | 139 |
| Bottom Line | 149 |
| PART TWO | |
| Strategy, Taxes, and Risk Management | 151 |
| CHAPTER 6 | |
| Strategy and Financial Planning | 153 |
| Strategy and Value | 155 |
| Financial Planning and Budgeting | 158 |
| Importance of Financial Planning | 158 |
| Budgeting Process | 160 |
| Sales Forecasting | 161 |
| Seasonal Considerations | 163 |
| Budgeting | 165 |
| Pro Forma Financial Statements | 172 |
| Long-Term Financial Planning | 179 |
| Financial Modeling | 179 |
| Performance Evaluation | 183 |
| Strategy and Value Creation | 191 |
| Bottom Line | 195 |

| | |
|--|------------|
| CHAPTER 7 | |
| Basics of Corporate Taxes and Tax Risk Management | 197 |
| Tax Management | 199 |
| Tax Risk | 200 |
| U.S. Tax Law and Taxation of Corporations | 205 |
| State and Local Taxes | 218 |
| Non-U.S. Taxes | 218 |
| Bottom Line | 224 |
| CHAPTER 8 | |
| Corporate Risk Management | 227 |
| Risk Defined | 228 |
| Enterprise Risk Management | 230 |
| Managing Risks | 235 |
| Risk Transfer | 237 |
| Bottom Line | 255 |
| PART THREE | |
| Performance Evaluation | 259 |
| CHAPTER 9 | |
| Financial Ratio Analysis | 261 |
| Ratios and Their Classification | 262 |
| Return-on-Investment Ratios | 264 |
| Liquidity | 271 |
| Profitability Ratios | 279 |
| Activity Ratios | 282 |
| Financial Leverage Ratios | 284 |
| Common-Size Analysis | 289 |
| Using Financial Ratio Analysis | 290 |
| Illustration: Pfizer, Inc., 1990–2005 | 292 |
| Bottom Line | 307 |

| | |
|---|------------|
| CHAPTER 10 | |
| Cash Flow Analysis | 309 |
| Difficulties with Measuring Cash Flow | 309 |
| Cash Flows and the Statement of Cash Flows | 311 |
| Free Cash Flow | 316 |
| Calculating Free Cash Flow | 318 |
| Net Free Cash Flow | 320 |
| Usefulness of Cash Flows in Financial Analysis | 322 |
| Bottom Line | 327 |
| CHAPTER 11 | |
| Decentralized Operations and Responsibility Accounting | 329 |
| Organization Structures and Concepts | 330 |
| Examples of Types of Organization Structure and Responsibility Reporting | 331 |
| Decentralization Problems | 337 |
| Responsibility Accounting | 338 |
| Controllable Costs | 345 |
| Costs of Service Departments | 346 |
| Executive Incentive Compensation Plans and Dysfunctional Decision Making | 347 |
| Bottom Line | 351 |
| CHAPTER 12 | |
| Responsibility Center Performance Evaluation | 353 |
| Basis for Comparison | 354 |
| Cost Center Performance Evaluation | 356 |
| Profit Center Performance Evaluation | 364 |
| Profit Center Decision Making | 372 |
| Investment Center Performance Evaluation | 373 |
| Bottom Line | 394 |
| Appendix: Gross Profit Analysis | 394 |
| CHAPTER 13 | |
| Transfer Pricing | 405 |
| Transfer Pricing Methods | 407 |
| Dual Transfer Pricing System | 418 |
| International Transfer Pricing | 419 |
| Bottom Line | 424 |

| | |
|---|------------|
| PART FOUR | |
| Asset Management | 427 |
| CHAPTER 14 | |
| Capital Budgeting and Cash Flow Analysis | 429 |
| The Investment Problem | 430 |
| Capital Budgeting | 432 |
| Cash Flow from Investments | 437 |
| Bottom Line | 454 |
| Appendix 14.A: Expected Cash Flows from the Disposition of an Asset | 455 |
| Appendix 14.B: Expansion of the Williams 5 & 10 | 457 |
| CHAPTER 15 | |
| Capital Budgeting Techniques | 463 |
| Evaluation Techniques | 464 |
| Net Present Value | 466 |
| Profitability Index | 471 |
| Internal Rate of Return | 472 |
| Modified Internal Rate of Return | 477 |
| Payback Period | 480 |
| Discounted Payback Period | 482 |
| Issues in Capital Budgeting | 483 |
| Comparing Techniques | 486 |
| Capital Budgeting Techniques in Practice | 489 |
| Conflicts with Responsibility Center Performance Evaluation Measures | 490 |
| Capital Budgeting and the Justification of New Technology | 491 |
| Bottom Line | 495 |
| CHAPTER 16 | |
| Capital Budgeting and Risk | 497 |
| Project Risk | 498 |
| Measurement of Project Risk | 500 |
| Measuring a Project's Market Risk | 505 |
| Incorporating Risk in the Capital Budgeting Decision | 514 |
| Real Options | 518 |
| Certainty Equivalents | 525 |
| Assessment of Project Risk in Practice | 526 |
| Bottom Line | 528 |

| | |
|---|------------|
| CHAPTER 17 | |
| Leasing | 531 |
| How Leasing Works | 532 |
| Types of Equipment Leases | 533 |
| Full-Payout Leases versus Operating Leases | 535 |
| Reasons for Leasing | 536 |
| Types of Lessors | 541 |
| Lease Brokers and Financial Advisers | 541 |
| Lease Programs | 542 |
| Financial Reporting of Lease Transactions by Lessees | 543 |
| Leveraged Lease Fundamentals | 546 |
| Federal Income Tax Requirements for True Lease Transactions | 556 |
| Synthetic Leases | 558 |
| Valuing a Lease: The Lease or Borrow-to-Buy Decision | 560 |
| Bottom Line | 574 |
| | |
| CHAPTER 18 | |
| Managing Short-Term Assets | 579 |
| Cash Management | 581 |
| Marketable Securities | 589 |
| Receivables Management | 591 |
| Inventory Management | 601 |
| Bottom Line | 607 |
| | |
| PART FIVE | |
| Cost and Managerial Accounting | 609 |
| | |
| CHAPTER 19 | |
| Classifying Costs | 611 |
| Elements of a Product | 612 |
| Relationship to Production | 615 |
| Relationship to Volume | 616 |
| Ability to Trace | 622 |
| Department Where Incurred | 623 |
| Functional Areas | 624 |
| Period Charge in Income | 625 |
| Relationship to Planning, Controlling, and Decision Making | 626 |
| Techniques for New Product Cost Estimation | 629 |
| Bottom Line | 633 |

| | |
|--|------------|
| CHAPTER 20 | |
| Costing and Control of Materials, Labor, and Factory Overhead | 635 |
| Materials (Stores) | 636 |
| Labor | 641 |
| Factory Overhead Costs | 646 |
| Activity-Based Costing | 660 |
| Bottom Line | 664 |
| CHAPTER 21 | |
| Job Order and Process Costing | 667 |
| Comparison of Job Order and Process Cost Accumulation Systems | 668 |
| Job Order Costing | 669 |
| Operation Costing | 673 |
| Project Costing | 674 |
| Process Costing | 676 |
| Backflush Costing | 694 |
| Bottom Line | 695 |
| Appendix: Spoiled Units, Defective Units, Scrap Material, and Waste Material in Job Order and Process Costing Systems | 697 |
| CHAPTER 22 | |
| Joint Product and By-Product Costing | 703 |
| Joint Products | 703 |
| By-Products | 711 |
| Effects of Joint Cost Allocation upon Decision Making | 715 |
| Bottom Line | 716 |
| CHAPTER 23 | |
| Master Budget | 719 |
| Conventional Master Budget System | 721 |
| Budgeted Schedules | 723 |
| Budgeted Summaries | 740 |
| Bottom Line | 744 |
| CHAPTER 24 | |
| Standard Costing | 749 |
| Actual, Normal, and Standard Costing | 750 |
| Uses of Standard Costs | 751 |

| | |
|---|------------|
| Types of Standards | 752 |
| Establishment of Standards | 753 |
| Just-in-Time Philosophy and Cost Accounting | 764 |
| Variance Analysis | 769 |
| Disposition of All Variances | 786 |
| Bottom Line | 788 |
| CHAPTER 25 | |
| Direct and Absorption Costing | 791 |
| Meaning of Direct Costing | 791 |
| Direct Costing versus Absorption Costing | 792 |
| Advantages of Direct Costing | 802 |
| Disadvantages of Direct Costing | 805 |
| Adjusting Financial Statements for External Reports | 807 |
| Bottom Line | 807 |
| Index | 809 |

Preface

The role of financial executives in any business has expanded significantly in recent years as companies become more accountable to their stakeholders and regulators. Combine this increase in accountability with the increasing sophistication of technology, risk management, financial analysis, and financial records processing, and we see that the responsibilities of financial executives in any organization have expanded significantly.

Our goal with *The Complete CFO Handbook* is to provide financial executives with the background and tools for managing a company's financial functions. The *Handbook* consists of five parts, each focusing on a different dimension of the financial executives' role.

In Part One we focus on funding issues, including the capital structure decision, the choice of debt financing, equity financing issues, and structured financings. We include the traditional capital structure theory and analysis, but our focus really is on the analysis of what companies do in practice. To this end, we include coverage of:

- How the Sarbanes-Oxley Act of 2002 affects the responsibilities and the role of the CFO.
- The governance value of debt financing.
- Costs of financial distress.
- Factors to consider when designing a bond issues.
- Alternative methods of repurchasing stock.
- Structured finance transactions.
- Credit enhancement in securitization.
- Structured notes.

In Part Two we address strategic planning, taxes, and risk management. The CFO is often playing a larger role in developing and executing the company's strategic plan, which means taking a broader view of the sources of value creation and of the company's risk management strategies. We include coverage of current issues to help the CFO better prepare for this broader view:

- Sources of value creation.
- The relation between economic value added and the balanced scorecard to strategic planning.

- Tax risk management.
- Transfer pricing and thin capitalization.
- Enterprise risk management.
- Retention risk management.
- Risk transfer management.

In Part Three we focus on performance evaluation, providing analysis tools for financial analysis that includes cash flow analysis and the analysis of budget variances. We include tools and topics to help the CFO analyze different dimensions of performance:

- DuPont system of analyzing return on investment ratios.
- Free cash flow and discretionary cash flow analysis.
- Responsibility accounting.
- Performance reports.
- Flexible budgets.
- Variance analysis.
- Transfer pricing systems and related tax issues.

In Part Four we look at asset management, which includes long-term and short-term asset management. With respect to long-term asset management, we examine traditional capital budgeting methods, including estimating cash flows and applying valuation techniques. In addition, we take a look at how capital budgeting is applied in practice. The CFO faces an array of asset management techniques and tools. To help prepare the CFO for this array, we include coverage of:

- Adjusted present value method.
- Real options applied to capital budgeting.
- Tax and non-tax-oriented leasing.
- Leveraged leasing.
- Cash conversion cycle analysis.

In Part Five we cover the traditional managerial accounting topics of classifying costs, job order costing, direct and absorption costing, and standard costing. The costing methods are fairly detailed and we have summarized the primary methods. In addition, we include coverage to help the CFO gain a perspective on these costs, including:

- The relation between costs and planning, controlling, and decision making.
- Activity-based costing.

- Process costing.
- Costing for by-products.
- Comparison of direct and absorption costing.
- JIT management and the costs of manufacturing.
- The interrelationships among the different budgets within a company.

Acknowledgment

We wish to thank Jacob Thomas of Yale University for his helpful comments on several chapters of this book.

Frank J. Fabozzi
Pamela Peterson Drake
Ralph S. Polimeni

About the Authors

Frank J. Fabozzi, PhD, CFA, CPA, is Professor in the Practice of Finance in the School of Management at Yale University. Prior to joining the Yale faculty, he was a Visiting Professor of Finance in the Sloan School at MIT from 1986–1992. He is a Fellow of the International Center for Finance at Yale University and on the Advisory Council for the Department of Operations Research and Financial Engineering at Princeton University. Professor Fabozzi earned a doctorate in economics from the City University of New York in 1972. He has authored and edited numerous books in finance.

Pamela Peterson Drake, PhD, CFA, is the J. Gray Ferguson Professor of Finance and Department Head of Finance and Business Law at James Madison University. Previous to joining James Madison University, she was an Associate Dean and Professor of Finance at Florida Atlantic University. Professor Peterson Drake received her Ph.D. from the University of North Carolina at Chapel Hill and joined the faculty of Florida State University in 1981. Professor Peterson Drake is an author and co-author on a number of books, including *Analysis of Financial Statements* (2nd ed., John Wiley & Sons, Inc., 2006) and *Financial Management and Analysis* (2nd ed., John Wiley & Sons, Inc., 2003), both with Frank Fabozzi, and *Real Options* (AIMR Research Foundation, 2002), with Don Chance. Professor Peterson Drake has published numerous articles in academic and practitioner journals.

Ralph S. Polimeni, PhD, CPA, is the Vice Provost for Accreditation and Assessment and holds the Chaykin Endowed Chair in Accounting at Hofstra University. Prior to his current position, Professor Polimeni served as Dean of the Frank G. Zarb School of Business for 11 years. He was also Department Head of the Accounting, Taxation and Legal Studies in Business Department at Hofstra University for 21 years. In 1978 Professor Polimeni received the University's Distinguished Teacher Award. He has a Ph.D. in business with a major in accounting. Professor Polimeni is an author and co-author on numerous articles and books in accounting.

The Changing Role of the CFO: From Accounting to Accountable

JOB DESCRIPTION: Oversee financial accounting systems, reporting, and disclosures; assure compliance of financial reporting with generally accepted accounting principles and securities law accounting requirements; assure compliance with local government, federal government, and international tax laws, regulations, and rules; expert in disclosure compliance with federal and state securities laws; establish, monitor, and evaluate internal controls; work with the CEO in the development of the strategic goals and plans, execute the strategic plans, and evaluate performance relative to the strategic goals; participate in long-term and short-term budgeting; exceptional communication and team leadership skills; able to raise capital and manage the firms' capital structure to maximize the value of the company and minimize the company's cost of capital; develop, monitor, and evaluate a program of risk management; communicate with the company's Board of Directors, shareholders, creditors, and credit rating agencies; no sensitivity to the effects of kryptonite.

Many years ago, the role of the *chief financial officer (CFO)* was to keep the financial records, and had accounting, internal control, budgeting, and treasury responsibilities. But the role has changed over the years to be much more comprehensive and to include decision-making that extends beyond the accounting and treasury functions. The CFO of today is responsible for measuring and monitoring performance, but the CFO is also now involved in managing risk and creating value for owners.

What has caused this change? There is not just one cause; but rather several forces that have resulted in the expanded role of the CFO. In the 1990s, we saw the role expanded from financial accounting and accounting systems to include financial analysis and an active role in strategic planning.¹ This expanding role is apparent in the Chief Financial Officers Act of 1990, which

¹ *The Practice of Management Accounting*, Institute of Management Accountants (Montvale, NJ, 1996), and *Reinventing the CFO: Moving from Financial Management to Strategic Management*, Coopers and Lybrand (New York, 1997).

specifically addressed the changing role of the CFO in federal government entities.² In the 1980s and 1990s, with the continued globalization and technological innovations, the CFO in some companies became a starring role as a deal-maker who sought out growth opportunities for the company.

The role of the CFO widened further because of the financial scandals of the 1990s and early 2000s that included Enron, WorldCom, and, unfortunately, many more companies. The resultant changes in laws and regulations focused attention on the CFO and broadened the responsibilities of this position. This resulted in a renewed emphasis on the CFO's role in accounting and financial reporting, but also added responsibilities for restoring confidence in the integrity of the company's financial accounting, internal control systems, and risk management.

Throughout this book, we discuss the responsibilities of the CFO in an organization. We recognize that in large companies the responsibilities of the CFO may be shared with the controller, a vice-president of finance, the corporate treasurer, a chief risk officer, or some other, similarly titled individual. However, in referring to the CFO, we are referring to responsibilities of the financial officer with the ultimate responsibility for the financial decision making of a company, responsibilities that may be shared or split among persons in the organization.

SOX ACT OF 2002 AND THE CFO

The *Sarbanes-Oxley Act of 2002* (SOX Act) is the most wide-sweeping legislation to affect the securities industry since the Securities Act of 1933 and the Securities Exchange Act of 1934.³ The SOX Act was passed as a reaction to the failures of corporate governance that were pronounced in scandals such as Enron.⁴ The SOX Act affects many participants in our financial markets: investors, security analysts, corporate management, and accountants. The Act includes provisions to increase internal monitoring, regulate the gatekeepers (e.g., chief executive officer, CFO, and the board of directors), penalize insider misconduct, and increase transparency.

We summarize the key provisions of this Act in Table 1.1. The SOX Act came about following numerous financial scandals that involved publicly

² The role of the CFO, as expressed in the Chief Financial Officers Act of 1990 [Public Law 101-576], was expanded by the Government Management Reform Act of 1994 [Public Law 103-356].

³ Public Law 107-204, July 30, 2002.

⁴ For an overview of the failures in the case of Enron, see William C. Powers, Jr., Raymond S. Troubh, and Herbert S. Winokur, Jr., *Report of Investigation by the Special Investigative Committee of the Board of Directors of Enron Corp.* (February 1, 2002), 2002 WL 198018 ("Powers Report").

TABLE 1.1 Key Provisions of the Sarbanes-Oxley Act of 2002

| | |
|-----------|--|
| Title I | <p>Public Company Accounting Oversight Board</p> <ul style="list-style-type: none"> ■ Establishes the oversight board, as well as provides policies and procedures for registration of accounting firms. The purpose of the board is to provide oversight of auditing firms and develop standards for auditors, auditing, and auditing reports, as well as to inspect accounting firms for compliance [Sec. 101]. |
| Title II | <p>Auditor Independence</p> <ul style="list-style-type: none"> ■ Prohibits most types of non-audit services of client by auditing accounting firm [Sec. 201]. Any non-audit service by an auditor must be approved by the audit committee of the client [Sec. 202]. |
| Title III | <p>Corporate Responsibility</p> <ul style="list-style-type: none"> ■ Requires that members of the client's audit committee be independent (i.e., not an employee of the client or consultant or adviser other than in capacity as a member of the board of directors.) [Sec. 301]. ■ Requires certification of the annual and quarterly filings with the SEC by the chief financial officer and the chief executive officer, attesting to the internal controls of the firms [Sec. 302]. ■ Prohibits improper influence on audits [Sec. 303]. ■ Specifies forfeiture of bonuses and profits on securities in the event of financial restatements [Sec. 304]. ■ Prohibits insider trading during pension fund blackouts and requires sufficient communication to fund participants and beneficiaries in the event of a blackout period [Sec. 306]. |
| Title IV | <p>Enhanced Financial Disclosures</p> <ul style="list-style-type: none"> ■ Enhances disclosure of off-balance-sheet transactions [Sec 401]. ■ Requires reconciliation of pro forma financial information with results according to generally accepted accounting principles [Sec. 401]. ■ Prohibits many types of personal loans to directors or executives [Sec. 402]. ■ Increases disclosure requirements for transactions with directors, executives, and principal shareholders [Sec. 403]. ■ Requires disclosure of whether the firm has a code of ethics for financial officers [Sec. 406]. ■ Requires disclosure of whether there is at least one financial expert on the audit committee [Sec. 407]. |
| Title V | <p>Analyst Conflicts of Interest</p> <ul style="list-style-type: none"> ■ Increases the independence of analysts and investment banking activities and requires disclosure of potential conflicts of interest of analysts [Sec. 501]. |

TABLE 1.1 (Continued)

| | |
|------------|--|
| Title VII | Studies and Reports <ul style="list-style-type: none"> ■ Requires studies of the accounting industry [Sec. 701], the credit-rating industry [Sec. 702], violators of securities laws, enforcement actions [Sec. 704], and investment banks [Sec. 705]. |
| Title VIII | Corporate and Criminal Fraud Accountability <ul style="list-style-type: none"> ■ Imposes criminal penalties for destruction of documents [Sec. 802]. ■ Provides whistleblower protection in fraud actions [Sec. 806]. ■ Provides criminal penalties for defrauding shareholders [Sec. 807]. |
| Title IX | White-Collar Crime Penalty Enhancements <ul style="list-style-type: none"> ■ Provides increased criminal penalties for white-collar crimes, such as mail and wire fraud [Sec. 902]. ■ Imposes criminal penalties for false certification of financial reports [Sec. 906]. |
| Title XI | Corporate Fraud and Accountability <ul style="list-style-type: none"> ■ Imposes fines and possible imprisonment for tampering with documents in an investigation [Sec. 1102]. ■ Provides the SEC with authority to freeze payments in the event of an investigation [Sec. 1103]. |

traded corporations, accountants, investment bankers, and brokers, with most of the provisions of the SOX Act traceable to specific misdeeds. For example, the provision for the reimbursement of bonuses prevents lucrative exits of executives from companies that were involved in accounting misstatements, such as those that occurred at Gateway.⁵ As another example, the provision for the independence of the audit committee members from management of the company prevents management from participating in the dealings with auditors, which was a problem in the case of Adelphia Communications.⁶

The provisions of SOX 2002 that directly affect the CFO include the following:

- *Section 206*: This section reduces potential conflicts of interest by making it unlawful for a CFO, CEO, controller, or equivalent officer to have

⁵ *Securities and Exchange Commission v. John J. Todd, Robert D. Manza, and Jeffrey Weitzen*, Complaint for Violations of the Federal Securities Laws.

⁶ Adelphia's audit committee at the end of 1999 comprised three members: Perry Patterson, Pete J. Metros, and Timothy J. Rigas, and was charged with the responsibility of monitoring and financial reporting for investors and the board of directors (Adelphia Communications Corporation Definitive Proxy Statement, Schedule 14A, filed July 7, 2000). However, Rigas was the company's executive vice president, CFO, chief accounting officer, and treasurer, which means that he was responsible for monitoring himself.

been employed by the independent public accounting firm and have participated in the audit of the company within one year of the audit.⁷

- *Section 302*: This section requires the CEO and CFO, or equivalent officers, to certify annual and quarterly reports and, in signing, they are responsible for the establishment and maintenance of internal controls. By certifying, they are also attesting to have reported any deficiencies to the auditors and the Audit Committee of the Board of Directors.
- *Section 304*: This section permits the Securities and Exchange Commission (SEC) to sue for forfeiture of any incentive-based, equity-based, or other bonus compensation of management in the event of a restatement of financial statements due to noncompliance. This provision deters management from manipulating reported financial accounting results for personal benefit.⁸
- *Section 401*: This section requires that periodic financial reports not only be presented accurately but be presented in a manner that includes incorrect statements or fails to state material information. It also requires that the issuer disclose material off-balance sheet transactions,⁹ contingent obligations, and other relationships between the issuer with unconsolidated entities such as special-purpose entities.¹⁰
- *Section 404*: This section requires disclosure of management assessment of internal controls and independent public accounting firm attestation of management's assessment. The requirement of reporting on internal controls imposed substantial startup costs on companies. More important, however, is the fact that this section creates a liability risk that is borne by the CEO and CFO. That is, the auditing firm and the executives signing off on the internal control report bear the liability for any failing in the internal control system.¹¹
- *Section 409*: This section requires real-time, plain-English disclosures of material changes in the company's operations or financial condition. The effect of this is (1) an expansion of the number of events that require a company filing a Form 8-K under the Securities and Exchange

⁷ Amendment to Section 10A of the Securities and Exchange Act of 1934.

⁸ However, as determined in the courts, this is a disgorgement action that must be brought by the SEC, not private parties [*Neer v. Pelino*, No. 04-CV-04791-SD (E.D. Pa. September 27, 2005)].

⁹ We discuss off-balance-sheet transactions in Chapter 3.

¹⁰ We discuss special-purpose entities in Chapter 5. Enron used these entities to create misleading financial statements.

¹¹ This increased liability risk may affect the risk-taking behavior of these executives, as suggested by Daniel A. Cohen, Aiyesha Day, and Thomas Lys, "The Sarbanes Oxley Act of 2002: Implications for Compensation Structure and Risk-Taking Incentives of CEOs," Working paper, July 8, 2005.

Act of 1934 from 9 to 22, and (2) a shortening of the deadline to four business days.¹²

- *Section 906*: This section requires certifications of audit reports by CEO and CFO with respect to compliance with securities laws and that the information represents fairly the financial condition and operating performance of the company. Criminal penalties are possible for certifications when in noncompliance.

EXPANDED RESPONSIBILITIES OF THE CFO

The broadening of responsibilities of the CFO has made this role less of a reactive, purely financial function, and more of a proactive role in the company's future, participating in many dimensions of the company's decision-making.

Traditionally, the CFO's responsibility related to accounting and treasury tasks. The traditional accounting functions included budgeting, forecasting, financial reporting, and performance measurement. Therefore, the CFO must be familiar with financial accounting, management accounting, and budgeting, and have an ability to communicate this information internally, as well as to creditors, shareholders, and others. The traditional treasury functions include capital structure decisions and investment decisions. Investment decisions include both working capital management as well as long-term capital investment, and require the CFO to be well versed in valuation principles.

The expansion in the role of the CFO includes compliance, risk management, communications, and performance evaluation. This expansion adds to the complexity of the role of the CFO, requiring an expanded knowledge of laws, rules, and regulations, an understanding of risk and the ability to communicate risk both internally and externally, and an ability to evaluate performance, using such tools as the balanced scorecard, economic value added, and other metrics. We illustrate the nexus of CFO responsibilities in Figure 1.1.

Compliance: Tax, Legal, and Regulatory

The compliance obligations of the CFO become more complicated as laws, regulations, and rules are created or change. For example, the CFO is re-

¹² *Final Rule: Additional Form 8-K Disclosure Requirements and Acceleration of Filing Date*, Securities and Exchange Commission [17 CFR Parts 228, 229, 230, 239, 240, and 249, RIN 3235-A147].

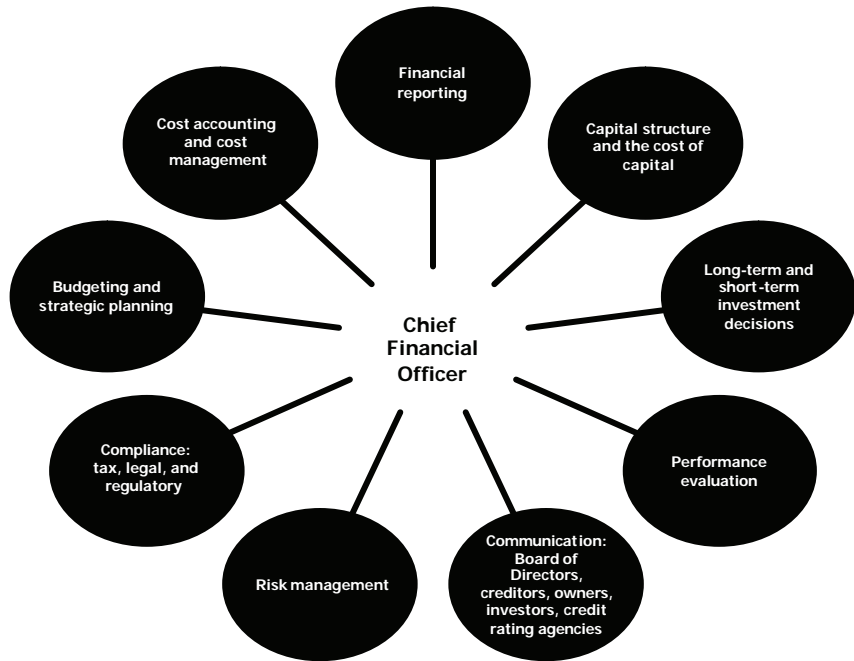
FIGURE 1.1 The CFO's Responsibilities

sponsible for expertise in laws, regulations, and rules that affect financial reporting, risk management, and the management of internal controls. The laws, regulations, and rules that the CFO must be familiar with include:

- Securities and Exchange Commission reporting requirements and regulations.
- Compliance with Sarbanes-Oxley Act of 2002.
- U.S. and international generally accepted accounting principles (GAAP).
- Internal Revenue Service reporting requirements and regulations.
- Compliance with U.S. Foreign Corrupt Practices Act (FCPA).¹³

Additionally, depending on the type of business, other laws and regulations may be relevant. These laws, regulations, and rules are all part of the responsibilities of the CFO, though many of these responsibilities may be shared with the controller.

¹³ Some of the challenges imposed by this law and the interaction with SOX Act of 2002 are in Tom Leander, "In China, You Better Watch Out," *CFO Asia*, March 20, 2006.

Additionally, the CFO must be aware of the changes that are on the horizon to effectively plan and forecast. For example, U.S. accounting standards are converging with International Financial Reporting Standards (IFRS) as the Financial Accounting Standards Board and the International Accounting Standards Committee (IASC) work out the differences in these standards. These changes in accounting standards affect financial reporting and may affect financial decisions. As another example, securities laws are tightening in a reactive manner to financial or accounting misdeeds and the CFO must grapple with the implications of these changes to financial disclosures and financial planning.

Communications

The CFO's role in company communications has changed such that the CFO is now an important player in communicating with the company's stakeholders—the creditors, shareholders, and others—not only the financial condition and operating performance of the company, but the risks and strategies of the company. The increased demand for transparency has expanded the type of information disclosed and the method of disclosure. Companies are now required to make real-time disclosures of material company events, which increases the pressure to provide accurate, current information. A number of the disclosures that U.S. publicly traded companies must make are summarized in Table 1.2.

The acceleration of the speed of disclosures began with Regulation FD. In an attempt to “level the playing field,” the Securities and Exchange Commission in 2000 adopted new rules regarding selective disclosure.¹⁴ These rules, in the form of the Fair Disclosure regulation (Regulation FD), require that if a publicly traded company or anyone acting on its behalf makes material, nonpublic information available to certain persons, the company must make a *public* disclosure of this information. All intentional disclosures are simultaneously to the public—not filtered through analysts, which was the previous custom. Now, if someone makes an *unintentional* disclosure, the company is required to make a prompt, public disclosure of the information. Regulation FD, combined with the real-time disclosures required under the new rules for 8-K filings due to the SOX Act of 2002, creates pressure on the CFO to be both fast and accurate.¹⁵

¹⁴ Securities and Exchange Commission, RIN 3235-AH82, “Selective Disclosure and Insider Trading,” effective October 23, 2000.

¹⁵ The significance of the communications and compliance burdens on the CFO is evident in recent surveys of CFOs. See, for example, Stephen Taub, “Survey: Sarbanes-Oxley Making CFO Job Tougher,” *CFO.com*, March 10, 2003, based on a survey by Deloitte Consulting and *BusinessWeek*.

TABLE 1.2 Summary of Filings of Publicly Traded Companies, Their Owners, and Executives

| Statement | Purpose | Information |
|---|---|---|
| 10-K report | Annual disclosure of financial information required of all publicly traded companies; due 90 days following the company's fiscal year-end. | Description of the company's business, financial statement data found in the company's annual report, notes to the financial statements, and additional disclosures including management's discussion and analysis. |
| 10-Q report | Quarterly disclosure by publicly traded companies; required 45 days following the end of each of the company's first three fiscal quarters. | A brief presentation of quarterly financial statements, notes, and management's discussion and analysis. |
| 8-K filing | Filed to report unscheduled, material events or events that may be considered of importance to shareholders of the SEC. | Description of significant events that are of interest to investors, filed as these events occur. |
| Prospectus | Filing made by a company intending to issue securities; registration statement complying with the Securities Act of 1933. | Basic company and financial information of the issuing company. |
| Proxy statement (Schedule 14A) ^a | Issued by the company pertaining to issues to be put to a vote by shareholders; complies with Regulation 14A; circumstances that are required for a vote are determined by state law. | Description of issues to be put to a vote; management's recommendations regarding these issues; compensation of senior management; shareholdings of officers and directors. |
| Registration statements (e.g., S-1, S-2, F-1) | A registration statement is a filing made by a company issuing securities to the public; required by the 1933 Act. | Financial statement information, as well as information that describes the business and management of the firm. |
| Schedule 13D | Filing made by a person reporting beneficial ownership of shares of common stock of a publicly traded company such that the filer's beneficial ownership is more than 5% of a class of registered stock; filed within 10 days of the shares' acquisition. | Report of an acquisition of shares, including information on the identity of the acquiring party, the source and amount of funds used to make the purchase, and the purpose of the purchase. |
| Schedule 14D-1 | Filing for a tender offer by someone other than the issuer such that the filer's beneficial ownership is more than 5% of a class of registered stock. | Report of an offer to buy shares including information on the identity of the acquiring party, the source and amount of funds used to make the purchase, and the purpose of the purchase, and the terms of the offer. |

^a There are different types of proxy: preliminary, confidential, and definitive. The most common is the definitive proxy, generally indicated with the abbreviation DEF (e.g., DEF 14A).

Strategic Planning

A company's CEO may be the primary person who works with the board of directors to establish the strategic plan, but the CFO is often being asked to work closely with the CEO in the company's strategic planning, in both the development of the strategy and its implementation.¹⁶ The finance function within a company is broadening to provide the bridge among the company's divisions, management, and the board of directors. In other words, the CFO makes the strategic plan happen and monitors the company's progress towards the strategic goals.

The CFO is involved in evaluating growth opportunities by assessing mergers, acquisitions, or joint venture opportunities, and by developing growth opportunities from within the company. The CFO is integral in bridging finance with strategy, bringing financial and knowledge and analytical skills to help the company achieve its strategic goals.

Performance Evaluation

The CFO has traditionally been instrumental in measuring performance because of the role played with respect to financial reporting, both internal and external. The CFO is in a good position to understand the drivers of performance, which is important in aligning incentives with performance. For example, if the performance of a division is attributable in part to factors controllable by the division manager and in part to factors outside of the control of the manager, the CFO can then attribute the performance of the division manager to the controllable portion of performance.

There are numerous management processes and tools that a company may choose from to gauge performance. We summarize a few of the many available management tools in Table 1.3. The key is to devise and implement a system that most closely aligns the reward with the performance. The CFO, in working with Human Resources, plays a role in setting the expectations for performance for the company's management and then communicating this to investors.

Performance evaluation and the related rewards are now the focus of a great deal of attention because of the backdated options scandals. Companies are rethinking the use of stock options to align employees' performance and rewards.¹⁷ In December 2006, the Securities and Exchange

¹⁶ The CFO surveys by Ernst & Young and Heidrick & Struggles are summarized in Mark L. Frigo, "Strategy, Value Creation, and the CFO," *Strategic Finance*, January 2003. In both surveys, strategic planning is one of the most important tasks from the viewpoint of the CFO.

¹⁷ Though many questioned the efficacy of using executive stock options to align management's interests with those of shareholders, the backdating scandals have

TABLE 1.3 Examples of Management Tools for Performance Evaluation

| Management Tool | Brief Summary |
|-------------------------------------|--|
| Activity-based costing ^a | Planning and control method that attributes costs to different products or services, based on cause-and-effect analysis. |
| Balanced scorecard ^b | Process of determining the company's strategy, identifying measures to evaluate whether the company is meeting its short-term and long-term goals, setting targets, and then providing feedback from these measures. |
| Economic value added ^c | Measure of financial performance that relates directly to shareholder value. |
| Six Sigma ^d | System evolved from quality engineering efforts that involve measuring defects in process and then providing feedback to improve quality. |

^a Robert S. Kaplan, "Measuring Manufacturing Performance: A New Challenge for Managerial Accounting Research," *The Accounting Review* 58 (October 1983), pp. 686–705.

^b Robert S. Kaplan and David P. Norton, *The Balanced Scorecard* (Boston: Harvard Business School Press, 1996), and Robert S. Kaplan and David P. Norton, *The Strategy-Focused Organization* (Boston: Harvard Business School Press, Harvard, 2001).

^c While formulated by the writings of economist Alfred Marshall in 1890, economic value added was commercialized by the firm of Stern Stewart and described in G. Bennett Stewart, *The Quest for Value* (New York: HarperCollins, 1999) and Al Ehrbar, *EVA: The Real Key to Creating Wealth* (New York: Wiley, 1998).

^d Bill Smith of Motorola is credited with the term *Six Sigma* and known as the Father of Six Sigma.

Commission issued new rules pertaining to the disclosure of executive compensation for publicly traded companies.¹⁸ These rules increase the transparency of the compensation by expanding and reorganizing the disclosure of compensation information in the Proxy Statement. The new presenta-

pushed the issue to the forefront. A *backdated option* is an executive option grant in which the date of the grant has been manipulated to provide greater benefits to the executive and to minimize taxes. Such manipulation, however, violates financial disclosure and tax laws. The recent problems related to the backdating of options, however, further frustrate the efforts to restore confidence in corporate management and financial statement reporting.

¹⁸ Executive Compensation Disclosure, Securities and Exchange Commission 17 CFR Parts 228 and 229, Release nos. 33-8765; 34-55009; File no. S7-03-06, RIN3235-AI80, December 22, 2006.

tion of compensation will provide increased transparency, but also provide a linkage of the information on the Proxy Statement with that shown on the company's financial statements. Though the SEC rules affect the top-paid executives in the company, the increased transparency of compensation for the highest-paid executives reflects the growing demand for alignment of rewards and performance at all levels of the company. Whereas the Compensation Committee of a company's board of directors establishes the compensation program for the top management of the company, the CFO has the responsibility of devising a system of compensation for all other levels of employees.

Risk Management

CFOs have come to play a more active role in managing the risk of a company. There are many dimensions to an enterprise's risk. The CFO is responsible for measuring and managing the many different types of risks a company faces. Risk management may involve the identification of risk, working with the board of directors to assess the firm's risk appetite and risk tolerance, deciding on what risks to retain and which risk to transfer, and formulating strategies to maintain a company's flexibility to respond to surprises. The CFO's arsenal for shifting risk goes beyond traditional insurance. Today the CFO has available other tools and strategies: derivatives, alternative risk transfer, and structured financial transactions. In large companies, the risk management responsibilities may be delegated, in part, to a chief risk officer (CRO) or the equivalent, but the CFO is nevertheless responsible for the management and communication of the company's risks.

The CFO has a vantage point that offers one of the best views of the company's risks. And a good understanding of an enterprise's risk helps the CFO in his or her strategic planning and forecasting role. The SOX Act provides additional motivation for the CFO to be involved in risk management. The SOX Act's emphasis on corporate governance and accountability imposes more responsibility on the CFO for risk transparency; therefore, understanding the risks of the business, developing the strategy for dealing with risk, and communicating the risk strategy to the Audit Committee and the Board of Directors is now more important than ever.

Fiduciary Duty

Spanning the traditional and added responsibilities of the CFO are the fiduciary duties of care and loyalty that the CFO owes to the company, its creditors, and its owners. These fiduciary duties require that the CFO put

the interests of the corporation and the owners ahead of other interests, including self-interest. These duties apply whether the issues relate to risk management cost control, performance evaluation, or any other area of responsibility. A corporation has many gatekeepers who have such a responsibility, notably the accountants and attorneys, members of the board of directors, and other officers. However, the CFO is in a unique position with respect to the perspective and the available information.

The relationship between the agent(s) and the principal(s) is formalized in *agency theory*, which describes the relation between the company's decision-makers—the officers, directors, and management—and its owners, and the issues related to potential conflicts of interest between agents and principals.¹⁹ In this theory, the *agents*—the officers, directors, and managers—have the responsibility to make decisions in the best interest of the *principal*—the owners. In a small business, the owners and managers are often the same, so there is no potential conflict of interest between the owners and the decision makers. However, in larger businesses, there is a separation of ownership and decision making, and therefore the owners must entrust directors, officers, and managers with the responsibility to make decisions on their behalf. There are costs associated with the consequences of the conflicts of interest that arise from the separation of ownership and decision making. These *agency costs* may be direct costs—such as the cost of printing and distributing annual reports—or indirect costs—such as excessive consumption of perquisites.

The mechanism that manages the potential conflicts of interest and the related costs is the *corporate governance system*. Many of the more notorious financial scandals of the 1990s and early 2000s arose from failures in corporate governance systems. In response to these scandals, there is a renewed emphasis on effective corporate governance. The changes in laws and regulations—most notably the Sarbanes-Oxley Act of 2002—and increasing pressure from the business community have increased the visibility and importance of accountability and responsibility through corporate governance. The certification of financial reports now required under Sarbanes-Oxley Act of 2002 is just one of many examples of the reforms in securities laws that require accountability from the CFO.

The CFO, as an officer of a business, must serve the interests of the stakeholders of the business. These stakeholders include the capital market participants, the creditors, and the shareholders. However, there is also a growing awareness of the other stakeholders of the business, including sup-

¹⁹ See Michael Jensen and William H. Meckling, "Theory of the Firm: Managerial Behavior, Agency Costs and Ownership Structure," *Journal of Financial Economics*, 3 (1976), pp. 305–360.

pliers, customers, and employees.²⁰ The increased role of the CFO expands not only the list of responsibilities of the CFO, but also the scope of the CFO's duty to owners, creditors, employees, and others.

OUR AGENDA

In this book, we provide an updated resource kit for the CFO. We cover topics that relate to the traditional role of the CFO, as well as the many new responsibilities of the CFO.

- We focus on raising capital and capital structure decisions in Part One. In addition to the discussion of the relation between capital structure, the cost of capital, and company value, we detail the different sources of debt financing and then discuss the issues related to equity financing, including dividends, repurchases, and classes of shares. We also discuss structured financial transactions—securitization, structured notes, and leasing—in this section.
- In Part Two, we discuss financial planning and risk management. Specifically we discuss the tools and processes by which a CFO may manage risk, including taxes, the enterprise risk management (ERM) process, and strategies for transferring risk.
- We provide coverage of performance evaluation in Part Three. Our focus in this part is on financial ratios and cash flow analysis and how the CFO can use these analyses to better understand the financial condition and operating performance of a company. We also discuss responsibility accounting, responsibility center performance, and transfer pricing in the context of performance evaluation.
- We focus on asset management in Part Four. We look at the fundamentals of the capital budgeting process, including cash flow estimation and the evaluation of cash flows in decision making. We also look at the management of the company's short-term assets (i.e., its working capital management) and leasing decisions.
- We cover the traditional cost accounting topics of product costing and strategic cost management in Part Five. These topics include classifying costs, cost control, costing, and the master budget.

²⁰ An example of this enhanced awareness of responsibility to stakeholders is the creation in 1999 of the Dow Jones Sustainability Index (DJSI), which is a benchmark that considers corporate governance, investor relations, risk management, scorecards, environmental management, employee satisfaction, and many other factors. The expanded role of the CFO includes responsibilities in the many dimensions of decision making that are captured in this index.

PART

One

Funding

Capital Structure Decisions

AGENDA

- Item 1* Summarize what is meant by the capital structure of a firm.
- Item 2* Identify the factors that affect the capital structure of a firm.
- Item 3* Evaluate the different measures of the extent of debt usage in a firm's capital structure: debt ratio, debt-to-total assets, debt-equity ratio, and debt-to-capital ratio.
- Item 4* Describe what is meant by operating and financial leverage.
- Item 5* Explain the advantages and disadvantages of leverage.
- Item 6* Describe the governance value of debt financing.
- Item 7* Analyze the impact of taxes on the capital structure decision.
- Item 8* Explain what is meant by financial distress and the effect of the costs of financial distress on the capital structure decision.
- Item 9* Interpret the role of the cost of capital in the capital structure decision and describe the process and issues related to estimating this cost.
- Item 10* Interpret what is meant by an optimal capital structure.
- Item 11* Describe the agency relationship and the problems associated with the agency relationship.

A business invests in new plant and equipment to generate additional revenues and income—the basis for its growth. One way to pay for investments is to generate capital from the company's operations. Earnings generated by the company belong to the owners and can either be paid to them—in the form of cash dividends—or plowed back into the company.

The owners' investment in the company is referred to as *owners' equity* or, simply, *equity*. If earnings are plowed back into the company, the owners expect it to be invested in projects that will enhance the value of the company and, hence, enhance the value of their equity. But earnings may not be sufficient to support *all* profitable investment opportunities. In that case the CFO is faced with a decision: Recommend that the CEO and the board forgo profitable investment opportunities or raise additional capital. A CFO can raise new capital either by borrowing or by selling additional ownership interests or both (see Figure 2.1).

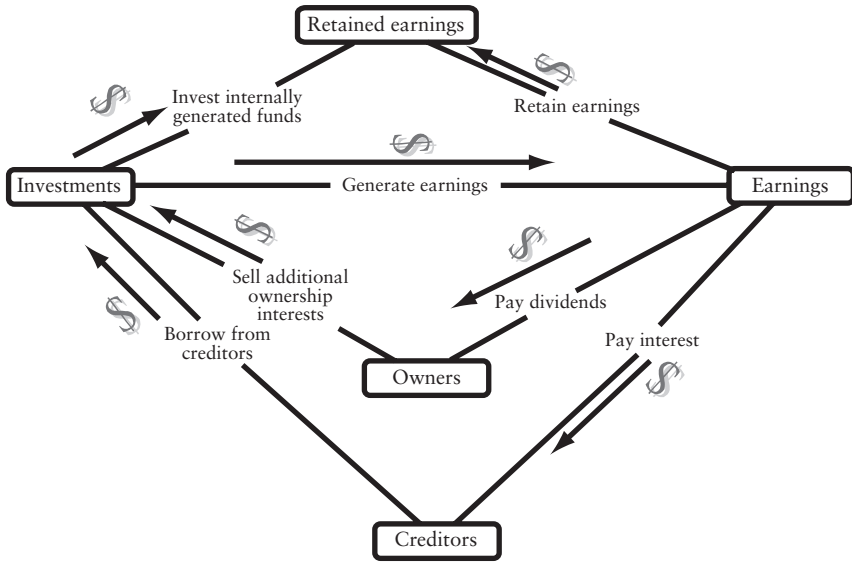
FIGURE 2.1 Financing a Company

In this chapter we discuss the decision about how the company should be financed: the mixture of debt and equity. This decision is referred to as the *capital structure decision*. In the appendix to this chapter we present a theory about the capital structure proposed by Franco Modigliani and Merton Miller.

DEBT VERSUS EQUITY

The capital structure of a company is some mix of debt, internally generated equity, and new equity. But what is the right mixture? The best capital structure depends on several factors. If a company finances its activities with debt, the creditors expect the amount of the interest and principal—fixed, legal commitments—to be paid back as promised. Failure to pay may result in legal actions by the creditors.

Suppose a company borrows \$100 million and promises to repay the \$100 million plus \$5 million in one year. Consider what may happen when the \$100 is invested:

- If the \$100 million is invested in a project that produces \$120, the company pays the lender the \$105 million the company owes and keeps the \$15 million profit.

- If the project produces \$105 million, the company pays the lender \$105 million and keeps nothing.
- If the project produces \$100 million, the company pays the lender \$105 million, with \$5 million coming out of company funds.

So if the company reinvests the funds and gets a return more than the \$5 million (the cost of the funds), the company keeps all the profits. But if the project returns \$5 million or less, the lender still gets her or his \$5 million. This is the basic idea behind *financial leverage*—the use of financing that has fixed, but limited payments.

If the company has abundant earnings, the owners reap all that remains of the earnings after the creditors have been paid. If earnings are low, the creditors still must be paid what they are due, leaving the owners nothing out of the earnings. Failure to pay interest or principal as promised may result in financial distress. *Financial distress* is the condition where a company makes decisions under pressure to satisfy its legal obligations to its creditors. These decisions may not be in the best interests of the owners of the company.

With equity financing there is no obligation. Though the company may choose to distribute funds to the owners in the form of cash dividends, there is no legal requirement to do so. Furthermore, interest paid on debt is deductible for tax purposes, whereas dividend payments are not tax deductible.

One measure of the extent debt is used to finance a company is the *debt ratio*, the ratio of debt to equity:

$$\text{Debt ratio} = \frac{\text{Debt}}{\text{Equity}}$$

This is a relative measure of debt to equity. The greater the debt ratio, the greater the use of debt for financing operations, relative to equity financing. Another measure is the *debt-to-assets ratio*, which is the extent to which the assets of the company are financed with debt:

$$\text{Debt-to-assets ratio} = \frac{\text{Debt}}{\text{Total assets}}$$

This is the proportion of debt in a company's capital structure, measured using the book or carrying value of the debt and assets.

It is often useful to focus on the long-term capital of a company when evaluating the capital structure of a company, looking at the interest-bearing debt of the company in comparison with the company's equity or with its capital. The *capital* of a company is the sum of its interest-bearing debt and its equity. The debt ratio can be restated as the ratio of the interest-bearing debt of the company to the equity:

$$\text{Debt-equity ratio} = \frac{\text{Interest-bearing debt}}{\text{Equity}}$$

and the debt-to-assets can be restated as the proportion of interest-bearing debt of the company's capital:

$$\text{Debt-to-capital ratio} = \frac{\text{Interest-bearing debt}}{\text{Total capital}}$$

By focusing on the long-term capital, the working capital decisions of a company that affect current liabilities, such as accounts payable, are removed from this analysis.

The equity component of all of these ratios is often stated in book or carrying value terms. However, when taking a markets perspective of the company's capital structure, it is often useful to compare debt capital with the market value of equity. In this latter formulation, for example, the total capital of the company is the sum of the interest-bearing debt and the market value of equity.

If market values of debt and equity are the most useful for decision making, should the CFO ignore book values? No, because book values are relevant in decision making also. For example, bond covenants are often specified in terms of book values or ratios of book values. As another example, dividends are distinguished from the return of capital based on the availability of the book value of retained earnings. Therefore, though the focus is primarily on the market values of capital, the CFO must keep an eye on the book value of debt and equity as well.

There is a tendency for companies in some sectors and industries to use more debt than others. We see this looking at the capital structure for different sectors in Figure 2.2, where the proportion of assets financed with debt and equity are shown graphically in terms of the book values of debt and equity. We can make some generalizations about differences in capital structures across sectors:

- Companies that are more reliant upon research and development for new products and technology—for example, pharmaceutical companies—tend to have lower debt-to-asset ratios than companies without such research and development needs.
- Companies that require a relatively heavy investment in fixed assets tend to have lower debt-to-asset ratios.

It is also interesting to see how debt ratios compare within sectors and within industries in a sector. For example, within the utilities sector, the electric utility industry has a lower use of debt than both the water and gas

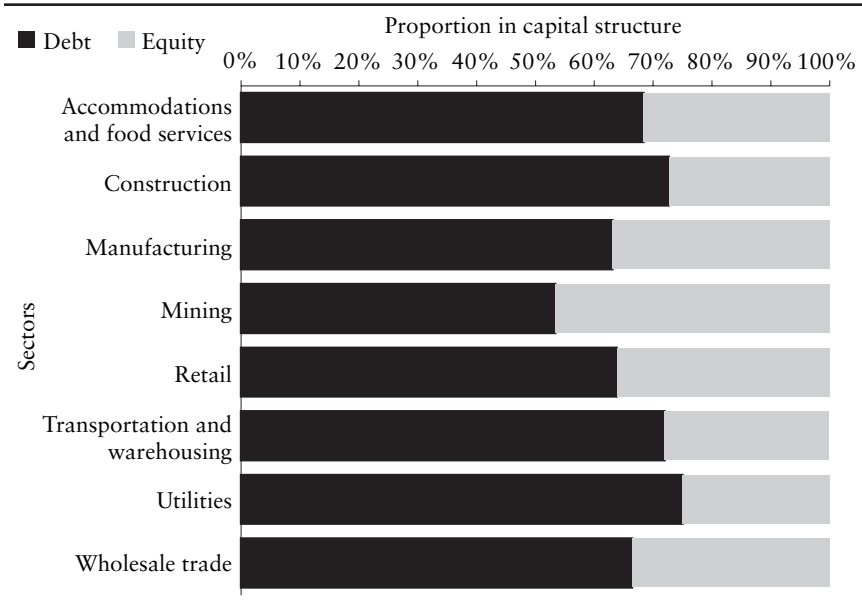
FIGURE 2.2 Proportions of Capital from Debt and Equity for Different Sectors, 2003

Source of data: *Statistics of Income*, www.irs.gov, Corporation Income Tax Returns, 2003.

industries. Yet within each industry there is variation of debt ratios. For example, within the beverage industry, Cott Corporation, maker of retail-brand soft drinks, has a much higher portion of debt in its capital structure than, say, the Coca-Cola Company.

Why do some industries tend to have companies with higher debt ratios than other industries? By examining the role of financial leveraging, financial distress, and taxes, we can explain some of the variation in debt ratios among industries. And by analyzing these factors, we can explain how the company's value may be affected by its capital structure.

CONCEPT OF LEVERAGE

The capital structure decision involves managing the risks associated with the company's business and financing decisions. The concept of *leverage*—in both its operations and its financing—plays a role in the company's risk because leverage exaggerates outcomes, good or bad.

Consider the simple example of a company that has both fixed and variable expenses. Suppose it has one product, with a sales price of \$100

per unit and variable costs of \$40 per unit. This means that the company has a \$60 profit per unit before considering any fixed expenses. This \$60 is the product's *contribution margin*—the amount that is available to cover any fixed expenses. Suppose the company's fixed expenses are \$20 million. If the company produces and sells 250,000 units, it has a loss of \$5 million; whereas if it produces and sells 1 million units, it has a profit of \$40 million. The company would have to produce and sell 1/3 million units before covering its fixed expenses; producing and selling more than 1/3 million produces a profit and producing less than 1/3 million generates a loss. This 1/3 million is the *break-even point*: the number of units produced and sold such that the product of the units sold and unit price just covers both the variable and fixed expenses.

The relation between the fixed costs, F , and the contribution margin can be specified in terms of the break-even quantity, Q_{BE} , the price per unit, P , the variable cost per unit, V , and the fixed costs:

$$Q_{BE} = \frac{F}{(P - V)}$$

Looking at the profit from a wider range of units produced and sold, as shown in Panel A of Figure 2.3, the profit is upward sloping, with a slope of \$60: Producing one additional unit produces a change in profit of \$60, which is the contribution margin. In contrast, consider a similar scenario, but with a variable cost per unit of \$20 and fixed costs of \$40. In this case, the break-even number of units produced and sold is 500,000. However, this latter case has a greater use of fixed costs. This produces a profit-units relation as shown in Panel B of Figure 2.3, with a slope of \$80. In the case of Panel B, there is more leverage: A greater relative use of fixed costs increases the losses and increases the profits.

Another way of quantifying the relation between the contribution margin and the fixed costs is using the degree of leverage measure:

$$\text{Degree of leverage} = \frac{Q(P - V)}{Q(P - V) - F}$$

The degree of leverage provides a measure of the sensitivity of the profit at a given level of production. In the above example with variable costs of \$40 per unit and fixed costs of \$20 million, the degree of leverage at 1 million units produced and sold is:

$$\text{Degree of leverage} = \frac{1 (\$100 - 40)}{1 (\$100 - 40) - \$20} = \frac{\$60}{\$40} = 1.5$$

At 2 million units, the degree of leverage is:

FIGURE 2.3 Leverage and Fixed Costs

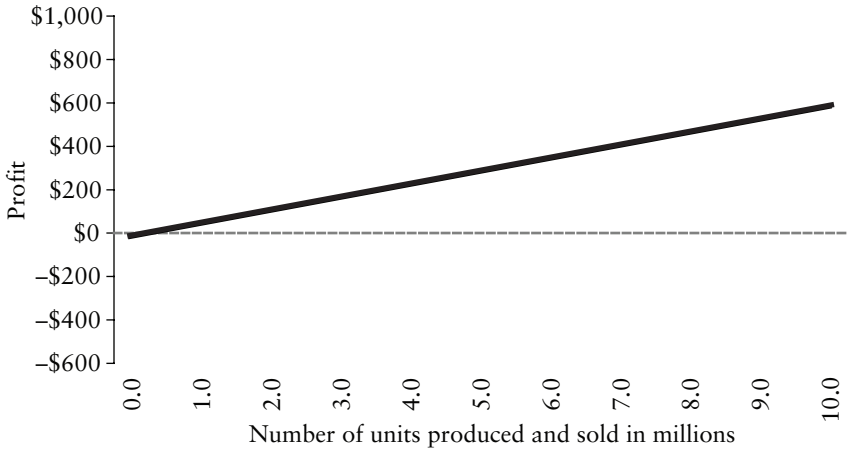

Panel A Variable cost = \$40 per unit, Fixed cost = \$20 million

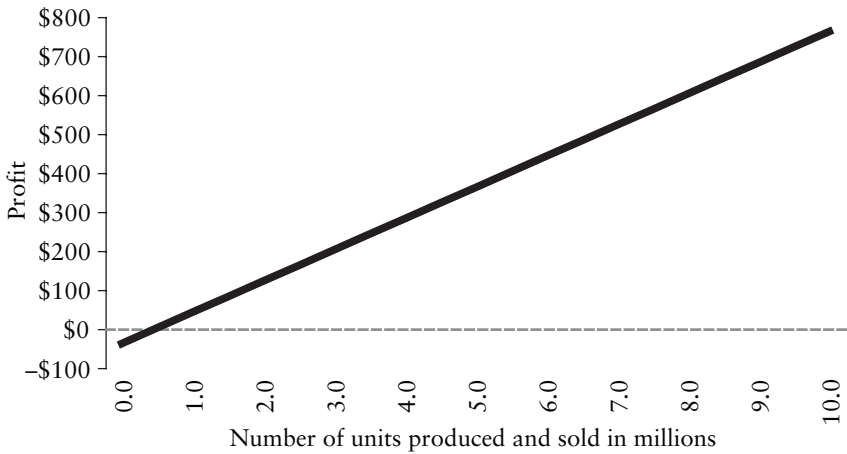

Panel B Variable cost = \$20 per unit, Fixed cost = \$40 million

$$\text{Degree of leverage} = \frac{2(\$100 - 40)}{2(\$100 - 40) - \$20} = \frac{\$120}{\$100} = 1.2$$

The degree of leverage is undefined at the break-even point—1/3 million units in this case—because the profit in the denominator is zero. The degree of leverage beyond the break-even point declines: As the company moves farther away from the break-even point, the effect of leverage—and hence risk—lessens, as shown in Figure 2.4.

Leverage and Operating Risk

The concept of leverage and the degree of leverage can be used to describe the operating risk of a company, which is a component of a company's business risk. *Business risk* is the uncertainty associated with the earnings from operations.

Business risk is uncertainty inherent in the type of business and can be envisioned as being comprised of sales risk and operating risk. *Sales risk* is the risk associated with sales as a result of economic and market forces that affect the volume and prices of goods or services sold. *Operating risk* is the risk associated with the cost structure of the company's assets. A cost structure is comprised of both fixed operating costs and variable operating costs. The greater the fixed costs relative to variable costs, the greater the leverage and, hence, operating risk. If sales were to decline, the greater the fixed costs in the operating cost structure the more exaggerated the effect on operating earnings.

FIGURE 2.4 The Degree of Leverage for Increasing Number of Units Produced and Sold beyond the Break-Even Point



In the context of the operating risk of a company, the degree of leverage is referred to as the *degree of operating leverage (DOL)*. In this case, the fixed costs that operate as a fulcrum in this leverage are specifically the fixed operating costs.

Leverage and Financial Risk

The effect of the mixture of fixed and variable costs on operating earnings is akin to the effect of debt financing on earnings to owners. Here it is referred to as *financial leverage*, which we describe shortly. The greater the fixed financing costs in the capital structure, the greater the leveraging effect on earnings to owners for a given change in operating earnings. The degree of leverage attributed to the capital structure of a company is referred to as the *degree of financial leverage (DFL)*.

Both operating leverage and financial leverage have a bearing on a company's financial risk. This is because of the compounding effect of operating leverage upon financial leverage, to affect the total leverage of the company. In fact, there is a multiplicative effect of the two leverages, such that the *degree of total leverage (DTL)* of a company, is the product of its degree of operating leverage and its degree of financial leverage:

$$DTL = DOL \times DFL$$

Therefore, the greater the business risk of the company, the greater the risk associated with a company's earnings to owners. The import of this is that a CFO must consider both the degree of operating leverage and the degree of financial leverage in managing the risk of the company.

CAPITAL STRUCTURE AND FINANCIAL LEVERAGE

Debt and equity financing create different types of obligations for the company. Debt financing obligates the company to pay creditors interest and principal—usually a fixed amount—when promised. If the company earns more than necessary to meet its debt payments, it can either distribute the surplus to the owners or reinvest. Equity financing does not obligate the company to distribute earnings. The company may pay dividends or repurchase stock from the owners, but there is *no* obligation to do so.

The fixed and limited nature of the debt obligation affects the risk of the earnings to the owners. Consider Capital Corporation, which has \$20 million of assets, all financed with equity. There are 1 million shares of Capital Corporation stock outstanding, valued at \$20 per share. The company's current balance sheet is simple:

Capital Corporation
Balance Sheet
in millions

| | | | |
|--------|------|--------|-----|
| Assets | \$20 | | |
| | | Debt | \$0 |
| | | Equity | 20 |

Suppose Capital Corporation has investment opportunities requiring \$10 million of new capital. Further suppose Capital Corporation can raise the new capital in one of three ways:

Alternative 1: Issue \$10 million equity (500 thousand shares of stock at \$20 per share).

Alternative 2: Issue \$5 million of equity (250 thousand shares of stock at \$20 per share) and borrow \$5 million with an annual interest of 10%.

Alternative 3: Borrow \$10 million with an annual interest of 10%.

Under each alternative, the capital structure is different:

Capital Corporation
Balance Sheet
in millions

| | | | |
|-----------------------|------|------------------------------|------|
| Alternative 1: | | | |
| Assets | \$30 | | |
| | | Debt | \$0 |
| | | Equity [1.5 million shares] | 30 |
| Alternative 2: | | | |
| Assets | \$30 | | |
| | | Debt | \$5 |
| | | Equity [1.25 million shares] | 25 |
| Alternative 3: | | | |
| Assets | \$30 | | |
| | | Debt | \$10 |
| | | Equity [1 million shares] | 20 |

It may be unrealistic to assume that the interest rate on the debt in Alternative 3 will be the same as the interest rate for Alternative 2, because in Alternative 3 there is more credit risk. For purposes of illustrating the point of leverage, however, let's keep the interest rate the same.

Stated differently, the debt ratio and the debt-to-asset ratio of Capital Corporation under each alternative are the following:

| Alternative | Debt-to-Equity Ratio | Debt-to-Capital Ratio |
|-------------|----------------------|-----------------------|
| 1 | 0.0% | 0.0% |
| 2 | 20.0% | 16.7% |
| 3 | 50.0% | 33.3% |

How can the CFO interpret these ratios? The debt ratio of 20% for Alternative 2 indicates that the company finances its assets using \$1 of debt for every \$5 of equity. The debt-to-assets ratio means that 16.7% of the assets are financed using debt or, in other words, almost 17 cents of every \$1 of assets is financed with debt.

Suppose Capital Corporation has \$4.5 million of operating earnings. This means it has a $\$4.5/\$30 = 15\%$ return on assets (ROA). And suppose there are no taxes. To illustrate the concept of financial leverage, consider the effect of this leverage on the earnings per share of a company. What are the earnings per share (EPS) under the different alternatives?

| | Alternative 1: \$10 Million Equity | Alternative 2: \$5 Million Equity and \$5 Million Debt | Alternative 3: \$10 Million Debt |
|--|--|--|--|
| Operating earnings <i>in millions</i> | \$4.5 | \$4.5 | \$4.5 |
| Less interest expense <i>in millions</i> | <u>0.0</u> | <u>0.5</u> | <u>1.0</u> |
| Net income <i>in millions</i> | \$4.5 | \$4.0 | \$3.5 |
| Number of shares <i>in millions</i> | <u>±1.5</u> | <u>±1.25</u> | <u>±1.0</u> |
| Earnings per share | \$3.00 | \$3.20 | \$3.50 |

Suppose that the return on assets is 10% instead of 15%. Then,

| | Alternative 1: \$10 Million Equity | Alternative 2: \$5 Million Equity and \$5 Million Debt | Alternative 3: \$10 Million Debt |
|--|--|--|--|
| Operating earnings <i>in millions</i> | \$3.0 | \$3.0 | \$3.0 |
| Less interest expense <i>in millions</i> | <u>0.0</u> | <u>0.5</u> | <u>1.0</u> |
| Net income <i>in millions</i> | \$3.0 | \$2.5 | \$2.0 |
| Number of shares <i>in millions</i> | <u>±1.5</u> | <u>±1.25</u> | <u>±1.0</u> |
| Earnings per share | \$2.00 | \$2.00 | \$2.00 |

If the company is earning a return that is the same as the cost of debt, 10%, the earnings per share are not affected by the choice of financing. Now suppose that the return on assets is 5%. The net income under each alternative is:

| | Alternative 1: \$10 Million Equity | Alternative 2: \$5 Million Equity and \$5 Million Debt | Alternative 3: \$10 Million of Debt |
|--|--|--|---|
| Operating earnings <i>in millions</i> | \$1.5 | \$1.5 | \$1.5 |
| Less interest expense <i>in millions</i> | <u>0.0</u> | <u>0.5</u> | <u>1.0</u> |
| Net income <i>in millions</i> | \$1.5 | \$1.0 | \$0.50 |
| Number of shares <i>in millions</i> | <u>±1.5</u> | <u>±1.25</u> | <u>±1.0</u> |
| Earnings per share | \$1.00 | \$0.80 | \$0.50 |

If the return on assets is 15%, Alternative 3 has the highest earnings per share, but if the return on assets is 5%, Alternative 3 has the lowest earnings per share.

This example illustrates the role of debt financing in the risk associated with earnings: The greater the use of debt vis-à-vis equity, the greater the risk associated with earnings to owners. Or, using the leverage terminology, the greater the degree of financial leverage, the greater the financial risk. Additionally, by comparing the outcomes for the different operating earnings scenarios—\$4.5, \$3.0, and \$1.5 million—the effect of adding financial risk in addition to the operating risk magnifies the risk to the owners.

Comparing the results of each of the alternative financing methods provides information on the effects of using debt financing. As more debt is used in the capital structure, there is greater “swing” in EPS.

Summarizing the EPS under each financing alternative and each economic climate:

| Financing Alternative | Earnings per Share Under Different Economic Conditions | | |
|--|---|-----------------------|---------------------|
| | Slow (ROA = 5%) | Normal (ROA = 10%) | Boom (ROA = 15%) |
| 1. \$10 million equity | \$1.00 | \$2.00 | \$3.00 |
| 2. \$5 million equity, \$5 million debt | \$0.80 | \$2.00 | \$3.20 |
| 3. \$10 million debt | \$0.50 | \$2.00 | \$3.50 |

When debt financing is used instead of equity (Alternative 3), the owners don't share the earnings—all they must do is pay their creditors the interest on debt. But when equity financing is used instead of debt (Alternative 1), the owners must share the increased earnings with the additional owners, diluting their return on equity and earnings per share.

FINANCIAL LEVERAGE AND RISK

The use of financial leverage (that is, the use of debt in financing a company), increases the range of possible outcomes for owners of the company. As we saw previously, the use of debt financing relative to equity financing increases both the upside and downside potential earnings for owners. In other words, financial leverage increases the risk to owners. Now that we understand the basics of leverage, let's quantify its effect on the risk of earnings to owners.

Leverage Effect

Equity owners can reap most of the rewards through financial leverage when their company does well. But they may suffer a downside when the company does poorly. What happens if earnings are down so low that it cannot cover interest payments? Interest must be paid no matter how low the earnings. How can money be obtained with which to pay interest when earnings are insufficient? It can be obtained in three ways:

1. By reducing the assets in some way, such as using working capital needed for operations or selling buildings or equipment.
2. By taking on more debt obligations.
3. By issuing more shares of stock.

Whichever the company chooses, the burden ultimately falls upon the owners.

This leveraging effect is illustrated in Figure 2.5 for Capital Corporation. Note that we have broadened the number of possible return-on-asset outcomes ranging from 0% to 30%. Alternative 3 provides for the most upside potential for the equity holders; it provides for the most downside potential as well. Hence, Alternative 1—all equity—offers the more conservative method of financing operations.

The three alternatives have identical earnings per share when there is a 10% return on assets. Capital Corporation's 10% return on assets is referred to as the *EPS indifference point*: the return where the earnings per share (EPS) are the same under the financing alternatives. Above a 10%

FIGURE 2.5 Capital Corporation's Earnings per Share for Different Operating Earnings for Each of the Three Financing Alternatives

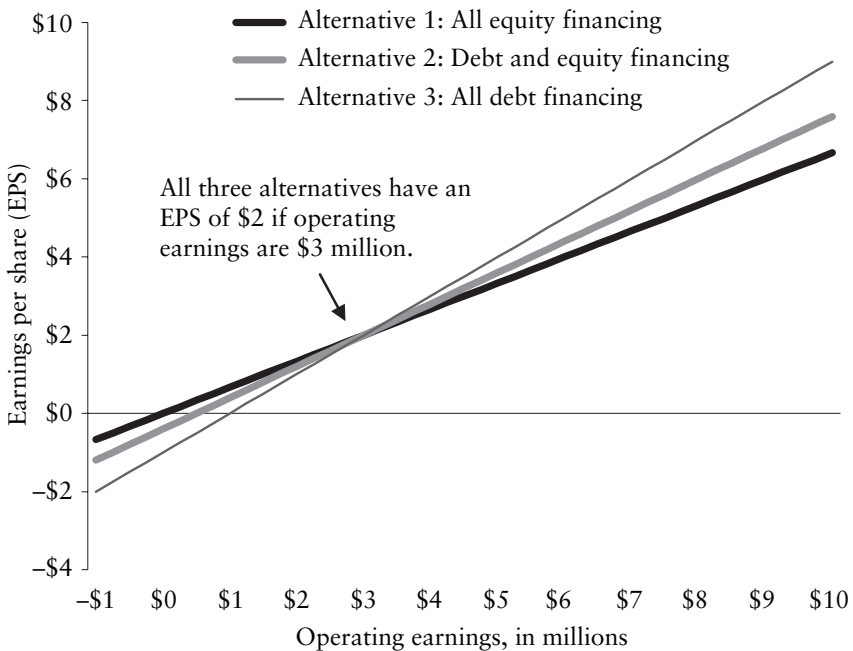

return on assets (that is, above operating earnings of \$3,000), Alternative 3 offers the most to owners. But Alternative 3 also has the most downside potential, producing the worst earnings to owners below this 10% return on assets.

Leverage and Financial Flexibility

The use of debt also reduces a company's financial flexibility. A company with debt capacity that is unused, sometimes referred to as *financial slack*, is more prepared to take advantage of investment opportunities in the future. This ability to exploit these future, strategic options is valuable; hence, taking on debt increases the risk that the company may not be sufficiently nimble to act on valuable opportunities.

There is evidence that suggests that companies that have more cash flow volatility tend to build up more financial slack; hence, their investments are not as sensitive to their ability to generate cash flows internally.¹ Rather,

¹ Lawrence Booth and Sean Cleary, "Cash Flow Volatility, Financial Slack, and Investment Decisions," working paper, January 2006, University of Toronto.

the financial slack allows them to exploit investment opportunities without relying on recent internally generated cash flows.

In the context of the effect of leverage on risk, this means that companies that tend to have high-volatility operating earnings may want to maintain some level of financial flexibility by not taking on significant leverage in the form of debt financing.

Governance Value of Debt Financing

A company's use of debt financing may provide additional monitoring of a company's management and decisions, reducing agency costs.² As explained later in this chapter, agency costs are the costs that arise from the separation of the management and the ownership of a company, which is particularly acute in large corporations. These costs are the costs necessary to resolve the agency problem that may exist between management and ownership of the company and may include the cost of monitoring company management. These costs include the costs associated with the board of directors and providing financial information to shareholders and other investors.

An agency problem that may arise in a company is how effectively a company uses its cash flows. The free cash flow of a company is, basically, its cash flow less any capital expenditures and dividends. One theory that has been widely regarded is that by using debt financing, the company reduces its free cash flows, and hence the company must reenter the debt market to raise new capital.³ It is argued that this benefits the company in two ways. First, there are fewer resources under control of management and less chance of wasting these resources in unprofitable investments. Second, the continual dependence on the debt market for capital imposes a monitoring, or governance discipline on the company that would not have been there otherwise.

CAPITAL STRUCTURE AND TAXES

We've seen how the use of debt financing increases the risk to owners; the greater the use of debt financing (vis-à-vis equity financing), the greater the risk. Another factor to consider is the role of taxes. In the United States, income taxes play an important role in a company's capital structure decision

² This is based on the theory developed by Jensen and Meckling. See Michael C. Jensen and William Meckling, "Theory of the Firm: Managerial Behavior, Agency Costs, and Ownership Structure," *Journal of Financial Economics* 4 (1976), pp. 305–360.

³ Michael C. Jensen, "Agency Cost of Free Cash Flow, Corporate Finance, and Takeovers," *American Economic Review* 76, 2 (May 1986), pp. 323–329.

because the payments to creditors and owners are taxed differently. In general, interest payments on debt obligations are deductible for tax purposes, whereas dividends paid to shareholders are not deductible. This bias affects a company's capital structure decision.

Interest Deductibility and Capital Structure

The deductibility of interest represents a form of a government subsidy of financing activities. By allowing interest to be deducted from taxable income, the government is sharing the company's cost of debt. To see how this subsidy works, compare two companies: Company U (unlevered) and Company L (levered). Suppose both have the same \$5 million taxable income before interest and taxes and contributed capital of \$35 million. Company U is financed entirely with equity, whereas Company L is financed with \$10 million debt that requires an annual payment of 10% interest. If the tax rate for both companies is 30%, the tax payable and net income to owners are calculated as follows:

| | Company U (no debt) | Company L (\$10 million debt) |
|---|------------------------|----------------------------------|
| Taxable income before taxes and interest <i>in millions</i> | \$5.0 | \$5.0 |
| Less interest expense <i>in millions</i> | <u>0.0</u> | <u>1.0</u> |
| Taxable income before taxes <i>in millions</i> | \$5.0 | \$4.0 |
| Less taxes at 30% of taxable income <i>in millions</i> | <u>1.5</u> | <u>1.2</u> |
| Net income to owners | \$3.5 | \$2.8 |

By financing its activities with debt, paying interest of \$1 million, Company L reduces its tax bill by \$0.3 million. Company L's creditors receive \$1 million of income, the government receives \$1.2 million of income, and the owners receive \$2.8 million. The \$0.3 represents money Company L does not pay because it is allowed to deduct the \$1 million interest. This reduction in the tax bill is a type of subsidy.

If Company LL (lots of leverage) has the same operating earnings and tax rate as Companies U and L, but uses \$20 million of debt at the 10% interest rate, the interest expense is \$2 million and net income to owners is \$2.1 million.

Comparing Company LL relative to Company L, we see that the interest expense is more, taxes are less, and net income to owners is less:

| | Company L (\$10 million debt) | Company LL (\$20 million debt) |
|---|-------------------------------------|--------------------------------------|
| Taxable income before taxes and interest <i>in millions</i> | \$5.0 | \$5.0 |
| Less interest expense <i>in millions</i> | <u>1.0</u> | <u>2.0</u> |
| Taxable income before taxes <i>in millions</i> | \$4.0 | \$3.0 |
| Less taxes at 30% of taxable income <i>in millions</i> | <u>1.2</u> | <u>0.9</u> |
| Net income to owners | \$2.8 | \$2.1 |

If Company L were to increase its debt financing from \$10 to \$20 million, like Company LL's, the total net income to the suppliers of capital—the creditors and owners—is increased \$0.3 million, from \$3.8 to \$4.1 million, determined as follows:

| | Company U (no debt) | Company L (\$10 million debt) | Company LL (\$20 million debt) |
|--|---------------------------|-------------------------------------|---|
| Income to creditors <i>in millions</i> | \$0.0 | \$1.0 | \$2.0 |
| Income to owners <i>in millions</i> | <u>3.5</u> | <u>2.8</u> | <u>2.1</u> |
| Total income to suppliers of capital | \$3.5 | \$3.8 | \$4.1 |

Consider this distribution of income between creditors and owners. The total income to the suppliers of capital increases from the use of debt. For example, the difference in the total income to suppliers of capital of Company U compared to Company LL is \$0.6 million. This difference is due to a tax subsidy by the government: By deducting \$2 million in interest expense, Company LL benefits by reducing taxable income by \$2 million and reducing taxes by $\$2 \text{ million} \times 30\% = \0.6 million .

The cost of capital for the company should be the same, no matter the method of financing.⁴ With a 10% cost of capital, the value to the suppliers of capital is split as follows:

⁴ We are assuming that there is no cost to financial distress; that is, taking on too much debt will not result in direct or indirect costs related to financial distress.

| | Company U (no debt) | Company L (\$10 million debt) | Company LL (\$20 million debt) |
|--|------------------------|----------------------------------|-----------------------------------|
| Capital contributed by: | | | |
| Creditors in mil- lions | \$0 | \$10 | \$20 |
| Owners in mil- lions | 35 | 25 | 15 |
| Contributed capi- tal in millions | \$35 | \$35 | \$35 |
| Value of the com- pany in millions ^a | \$35 | \$38 | \$41 |
| Value to creditors in millions | 0 | 10 | 20 |
| Value to owners in millions | \$35 | \$28 | \$21 |
| Add value from debt in millions ^b | \$0 | \$3 | \$6 |

^a The value is calculated by dividing the income stream for the company by the discount rate of 10%.

^b The added value from debt is the difference between the value of the levered company and the unlevered company (that is, Company U).

Who benefits from this tax deductibility? The owners do. The owners of Company U have a return on equity of \$3.5 million/\$35 million = 10%. Compare this to the owners of Company L, for which owners have a return on equity of \$2.8 million/\$25 million = 11.2%, and to the owners of Company LL, who have a return on equity of \$2.1 million/\$15 million = 14%. The owners of the levered firms benefit from the tax deductibility of interest in terms of the return on their investment.

Interest Tax Shield

An interesting element introduced into the capital structure decision is the reduction of taxes due to the payment of interest on debt. We refer to the benefit from interest deductibility as the *interest tax shield*, since the interest expense *shields* income from taxation. The tax shield from interest deductibility is:

$$\text{Tax shield} = \text{Tax rate} \times \text{Interest expense}$$

If Company L has \$10 million of 10% debt and is subject to a tax of 30% on net income, the tax shield is:

$$\text{Tax shield} = 0.30 [\$10 (0.10)] = 0.30(\$1) = \$0.3 \text{ million}$$

A \$1 million interest expense means that \$1 million of income is not taxed at 30%.

Recognizing that the interest expense is the interest rate on the debt, r_d , multiplied by the face value of debt, D , the tax shield for a company with a tax rate of τ is:

$$\text{Tax shield} = \text{Tax rate} \times \text{Interest expense} \times \text{Face value of debt}$$

$$\text{Tax shield} = \tau r_d D$$

How does this tax shield affect the value of the company? The tax shield reduces the net income of the company that goes to pay taxes. We should specify that the tax rate is the *marginal tax rate*—the tax rate on the next dollar of income.

And since the CFO is concerned with how interest protects income from taxation, the focus should be on how it shields taxable income beyond the income that is shielded by all other tax deductible expenses.

Unused Tax Shields

The value of a tax shield depends on whether the company can use an interest expense deduction. In general, if a company has deductions that *exceed* income, the result is a *net operating loss*. The company does not have to pay taxes in the year of the loss and may “carry” this loss to another tax year.

This loss may be applied against previous years’ taxable income (with some limits). The previous years’ taxes are recalculated and a refund of taxes previously paid is requested. If there is insufficient previous years’ taxable income to apply the loss against, any unused loss is carried over into future years (with some limits), reducing future years’ taxable income.⁵

Therefore, when interest expense is larger than income before interest, the tax shield is realized immediately—if there is sufficient prior years’ taxable income. If prior years’ taxable income is *insufficient* (that is, less

⁵ The tax code provisions, with respect to the number of years available for net operating loss carrybacks and carryovers, has changed frequently. For example, Internal Revenue Code permits a carryback for two previous tax years and a carryover forward for 20 future tax years [IRC Subtitle A, Chapter 1, Subchapter B, Part VI, Section 172 (b)].

than the operating loss created by the interest deduction), the tax shield is *less* valuable because the financial benefit is not received until some later tax year (if at all). In this case, we discount the tax shield to reflect both the uncertainty of benefiting from the shield and the time value of money.

To see how an interest tax shield may become less valuable, let's suppose the Unfortunate Company has the following financial results:

| The Unfortunate Company | | | |
|--------------------------------|--------------|--------------|--------------|
| | Year 1 | Year 2 | Year 3 |
| Taxable income before interest | \$7,000 | \$8,000 | \$6,000 |
| Interest expense | <u>5,000</u> | <u>5,000</u> | <u>5,000</u> |
| Taxable income | \$2,000 | \$3,000 | \$1,000 |
| Tax rate | <u>0.40</u> | <u>0.40</u> | <u>0.40</u> |
| Tax paid | \$800 | \$1,200 | \$400 |

Suppose further that the Unfortunate Company has the following result for Year 4:

| Year 4 | |
|--------------------------------|-----------------|
| Taxable income before interest | \$1,000 |
| Less: Interest expense | <u>8,000</u> |
| Net operating loss | <u>-\$7,000</u> |

Suppose the tax code permits a carryback of 2 years and a carryover of 20 years. Unfortunate Company can take the net operating loss of \$7,000 and apply it against the taxable income of the previous 2 years, beginning with Year 1:

| The Unfortunate Company | | | |
|--|--------------|---------------|---------------|
| Calculation of Tax Refunds Based on Year 4 Net Operating Loss | | | |
| | Year 1 | Year 2 | Year 3 |
| Taxable income before interest | \$7,000 | \$8,000 | \$6,000 |
| Interest expense | <u>5,000</u> | <u>5,000</u> | <u>5,000</u> |
| Taxable income—original | \$2,000 | \$3,000 | \$1,000 |
| Application of Year 4 loss | 0 | <u>-3,000</u> | <u>-1,000</u> |
| Taxable income—recalculated | | \$0 | \$0 |
| Tax due—recalculated | | <u>0</u> | <u>0</u> |
| Refund of taxes paid | | \$1,200 | \$400 |

By carrying back the part of the loss, the Unfortunate Company has applied \$4,000 of its Year 4 loss against the previous years' taxable income: 3,000(Year 2) + 1,000(Year 3) and receives a tax refund of $\$1,200 + 400 = \$1,600$. There remains an unused loss of $\$7,000 - \$4,000 = \$3,000$. This loss can be applied toward future tax years' taxable income, reducing taxes in future years. But since we don't get the benefit from the \$3,000 unused loss—the \$3,000 reduction in taxes—until sometime in the future, the benefit is worth less than if we could use it today.

The Unfortunate Company, with an interest deduction of \$8,000, benefits from \$5,000 of the deduction: \$1,000 against current income and \$4,000 against previous income. Therefore, the tax shield from the \$8,000 is not \$3,200 (40% of \$8,000), but rather \$2,000 (40% of \$5,000), plus the present value of the taxes saved in future years. The present value of the taxes saved in future years depends on:

- The uncertainty that Unfortunate Company will generate taxable income.
- The time value of money.

The Unfortunate Company's tax shield from the \$8,000 interest expense is less than what it could have been because the company could not use all of it now.

The bottom line of the analysis of unused tax shields is that the benefit from the interest deductibility of debt depends on whether or not the company can use the interest deductions.

CAPITAL STRUCTURE AND FINANCIAL DISTRESS

A company that has difficulty making payments to its creditors is in financial distress. Not all companies in financial distress ultimately enter into the legal status of bankruptcy. However, extreme financial distress may very well lead to bankruptcy. While bankruptcy is often a result of financial difficulties arising from problems in paying creditors, some bankruptcy filings are made prior to distress, when a large claim is made on assets (for example, class action liability suit).

Costs of Financial Distress

The costs related to financial distress without legal bankruptcy can take different forms. For example, to meet creditors' demands, a company takes on projects expected to provide a quick payback. In doing so, the financial

manager may choose a project that decreases owners' wealth or may forgo a profitable project.

Another cost of financial distress is the cost associated with lost sales. If a company is having financial difficulty, potential customers may shy away from its products because they may perceive the company as unable to provide maintenance, replacement parts, and warranties. Lost sales due to customer concern represent a cost of financial distress—an opportunity cost, something of value (sales) that the company would have had if it were not in financial difficulty.

Still another example of costs of financial distress is the costs associated with suppliers. If there is concern over the company's ability to meet its obligations to creditors, suppliers may be unwilling to extend trade credit or may extend trade credit only at unfavorable terms. Also, suppliers may be unwilling to enter into long-term contracts to supply goods or materials. This increases the uncertainty that the company will be able to obtain these items in the future and raises the costs of renegotiating contracts.

Role of Limited Liability

Limited liability limits owners' liability for obligations to the amount of their original investment in the shares of stock. Limited liability for owners of some forms of business creates a valuable right and an interesting incentive for shareholders. This valuable right is the right to default on obligations to creditors—that is, the right not to pay creditors. Because the most shareholders can lose is their investment, there is an incentive for the company to take on very risky projects: If the projects turn out well, the company pays creditors only what it owes and keeps the remainder, and if the projects turn out poorly, it pays creditors what it owes—if there is anything left.

The fact that owners with limited liability can lose only their initial investment—the amount they paid for their shares—creates an incentive for owners to take on riskier projects than if they had unlimited liability: They have little to lose and much to gain. They have an incentive to take on risky projects since they can lose only their investment in the company. But they can benefit substantially if the payoff on the investment is high.

For companies whose owners have limited liability, the more the assets are financed with debt, the greater the incentive to take on risky projects, leaving creditors holding the bag if the projects turn out to be unprofitable. This is a problem: There is a conflict of interest between shareholders' interests and creditors' interests. The investment decisions are made by management (who represent the shareholders) and, because of limited liability, there is an incentive for management to select riskier projects that

may harm creditors who have entrusted their funds (by lending them) to the company.

The right to default is a call option: The owners have the option to buy back the entire company by paying off the creditors at the face value of their debt. As with other types of options, the option is more valuable, the riskier the cash flows. However, creditors are aware of this and demand a higher return on debt (and hence a higher cost to the company).⁶ The result is that shareholders ultimately bear a higher cost of debt.

Bankruptcy and Bankruptcy Costs

When a company is having difficulty paying its debts, there is a possibility that creditors will foreclose (that is, demand payment) on loans, causing the company to sell assets, which could impair or cease operations. But if some creditors force payment, this may disadvantage other creditors. So what has developed is an orderly way of dealing with the process of the company paying its creditors—the process is called *bankruptcy*.

Bankruptcy in the United States is governed by the Bankruptcy Code, which is found under U.S. Code Title 11. A company may be reorganized under Chapter 11 of this Code, resulting in a restructuring of its claims, or liquidated under Chapter 7.

Chapter 11 bankruptcy provides the troubled company with protection from its creditors while it tries to overcome its financial difficulties. A company that files bankruptcy under Chapter 11 continues as a going concern during the process of sorting out which of its creditors get paid and how much. On the other hand, a company that files under bankruptcy Chapter 7, under the management of a trustee, terminates its operations, sells its assets, and distributes the proceeds to creditors and owners.

We can classify *bankruptcy costs* into direct and indirect costs. Direct costs include the legal, administrative, and accounting costs associated with the filing for bankruptcy and the administration of bankruptcy. The indirect costs of bankruptcy are more difficult to evaluate. Operating a company while in bankruptcy is difficult, since there are often delays in making decisions, creditors may not agree on the operations of the company, and the objectives of creditors may be at variance with the objective of efficient operation of the company.

⁶ Jensen and Meckling analyze the agency problems associated with limited liability in their article “Theory of the Company: Managerial Behavior, Agency Costs and Ownership Structure.” They argue that creditors are aware of the incentives the company has to take on riskier projects. Creditors will demand a higher return and may also require protective provisions in the loan contract.

Another indirect cost of bankruptcy is the loss in value of certain assets. If the company has assets that are intangible or for which there are valuable growth opportunities or options, it is less likely to borrow because the loss of value in the case of financial distress is greater than, say, for a company with marketable assets.⁷ Because many intangible assets derive their value from the continuing operations of the company, the disruption of operations during bankruptcy may change the value of the company. The extent to which the value of a business enterprise depends on intangibles varies among industries and among companies; so the potential loss in value from financial distress varies as well. For example, a drug company may experience a greater disruption in its business activities than, say, a steel manufacturer, since much of the value of the drug company may be derived from the research and development that leads to new products.

Financial Distress and Capital Structure

The relationship between financial distress and capital structure is simple: As more debt financing is used, fixed legal obligations increase (interest and principal payments), and the ability of the company to satisfy these increasing fixed payments decreases. Therefore, as more debt financing is used, the probability of financial distress and then bankruptcy increases.

For a given decrease in operating earnings, a company that uses debt to a greater extent in its capital structure (that is, a company that uses more financial leverage), has a greater risk of not being able to satisfy the debt obligations and increases the risk of earnings to owners.

Another factor to consider in assessing the probability of financial distress is the business risk of the company. As discussed earlier, the business risk interacts with the financial risk to affect the risk of the company.

The CFO's concern in assessing the effect of financial distress on the value of the company is the present value of the expected costs of financial distress. And the present value depends on the probability of financial distress: The greater the probability of financial distress, the greater the expected costs of financial distress.

The present value of the costs of financial distress increases with the increasing relative use of debt financing since the probability of financial distress increases with increases in financial leverage. In other words, as the debt ratio increases, the present value of the costs of financial distress

⁷ This is based on the reasoning set forth by Stewart C. Myers and Nicholas S. Majluf, "Corporate Financing and Investment Decisions When Firms have Information Investors Do Not Have," *Journal of Financial Economics* (June 1984), pp. 187-221.

increases, lessening some of the value gained from the use of tax deductibility of interest expense.

Summarizing the factors that influence the present value of the cost of financial distress:

- The probability of financial distress increases with increases in business risk.
- The probability of financial distress increases with increases in financial risk.
- Limited liability increases the incentives for owners to take on greater business risk.
- The costs of bankruptcy increase the more the value of the company depends on intangible assets.

The CFO does not know the precise manner in which the probability of distress increases as the debt-to-equity ratio increases. Yet, it is reasonable to think that:

- The probability of distress increases as a greater proportion of the company's assets are financed with debt.
- The benefit from the tax deductibility of interest increases as the debt-to-equity ratio increases.
- The present value of the cost of financial distress increases as the debt-to-equity ratio increases.

COST OF CAPITAL

The capital structure of a company is intertwined with the company's cost of capital. The *cost of capital* is the return that must be provided for the use of an investor's funds. If the funds are borrowed, the cost is related to the interest that must be paid on the loan. If the funds are equity, the cost is the return that investors expect, both from the stock's price appreciation and dividends. The cost of capital is a *marginal* concept. That is, the cost of capital is the cost associated with raising one more dollar of capital.

There are two reasons for determining a corporation's cost of capital. First, the cost of capital is often used as a starting point (a benchmark) for determining the cost of capital for a specific project. As explained in Chapter 16, where we discuss capital budgeting, the firm's cost of capital is adjusted upward or downward depending on whether the project's risk is more than or less than the firm's typical project.

Second, many of a firm's projects have risk similar to the risk of the firm as a whole. So the cost of capital of the firm is a reasonable approximation for the cost of capital of one of its projects that are under consideration for investment.

A firm's cost of capital is the cost of its long-term sources of funds: debt, preferred stock, and common stock. And the cost of each source reflects the risk of the assets the firm invests in. A firm that invests in assets having little risk will be able to bear lower costs of capital than a firm that invests in assets having a high risk. Moreover, the cost of each source of funds reflects the hierarchy of the risk associated with its seniority over the other sources. For a given firm, the cost of funds raised through debt is less than the cost of funds from preferred stock, which in turn is less than the cost of funds from common stock. This is because creditors have seniority over preferred shareholders, who have seniority over common shareholders. If there are difficulties in meeting obligations, the creditors receive their promised interest and principal before the preferred shareholders, who in turn receive their promised dividends before the common shareholders.

For a given firm, debt is less risky than preferred stock, which is less risky than common stock. Therefore, preferred shareholders require a greater return than the creditors and common shareholders require a greater return than preferred shareholders. Figuring out the cost of capital requires us to determine the cost of each source of capital the CFO expects to use, along with the relative amounts of each source of capital the CFO expects to raise. Then the CFO can determine the marginal cost of raising additional capital.

This can be done in three steps. In the first step the CFO determines the proportion of each source of capital to be used in the calculations. This should be based on the target capital structure selected by the CFO, not book values as per the balance sheet. The second step is then the calculation of the cost of each financing source. The cost of debt and preferred stock is fairly simple to obtain. The cost of equity is by far much more difficult to estimate. There are several models for the valuation of equity that can be used. What is critical to understand is that these different models can generate significantly different estimates for the cost of common stock and, as a result, the estimated cost of capital will be highly sensitive to the model selected. The proportions of each source must be determined before calculating the cost of each source since the proportions may affect the costs of the sources of capital. The last step is to weight the cost of each source of funding by the proportion of that source in the target capital structure.

For example, suppose that the CFO's target capital structure is as follows: 40% debt, 10% preferred stock, and 50% common stock. Assume further that the CFO estimates that the cost for raising an additional dollar of capital is as follows: 5% debt, 6% preferred stock, and 12% stock. If

the company's marginal tax rate is 40%, the after-tax cost of debt is $5\% \times (1 - 0.6) = 3\%$. Returning to the illustration, the weighted average cost of capital is 7.8% as shown below:

$$(40\% \times 3\%) + (10\% \times 6\%) + (50\% \times 12\%) = 7.8\%$$

This means that for every \$1 the CFO plans to obtain from financing, the cost is 7.8%.

As a company adjusts its capital structure, its cost of capital changes. Using more debt relative to equity will lower the cost of capital because the after-tax cost of debt is less than the cost of equity, up to a point. There is some point, however, when the likelihood and, hence, cost of financial distress increases and may in fact outweigh the benefit from taxes. After this point—wherever this may be—the cost of both debt and equity increases because both are much riskier.

Therefore, the trade-off theory of capital structure dictates that as the company uses more debt relative to equity, the value of the company is enhanced from the benefit of the interest tax shields.

But the theory also states that there is some point at which the likelihood of financial distress increases such that there is ever-increasing likelihood of bankruptcy. Therefore,

- The value of the company declines as more and more debt is used, relative to equity.
- The cost of capital increases because the costs of the different sources of capital increase.

Though the trade-off theory simplifies the world too much, it gives the CFO an idea of the trade-offs involved. Introduce the value of financial flexibility and the governance value of debt and the CFO has the key inputs to consider in the capital structure decision.

AGENCY RELATIONSHIP

The sole owner of a business makes decisions that affect his or her own well-being. But because the CFO of a corporation is not the sole owner, he or she is making decisions for the owners. The CFO is an agent. An *agent* is a person who acts for—and exerts powers of—another person or group of persons. The person (or group of persons) the agent represents is referred to as the *principal*. The relationship between the agent and his or her principal is an *agency relationship*. There is an agency relationship between the managers and the shareholders of corporations.

Problems with the Agency Relationship

In an agency relationship, the agent has the responsibility of acting for the principal. Is it possible the agent may not act in the best interest of the principal, but instead act in his or her own self-interest? Yes—because the agent has his or her own objective of maximizing personal wealth.

In a large corporation, for example, the managers may enjoy many fringe benefits, such as golf club memberships, access to private jets, and company cars. These benefits (also called perquisites, or “perks”) may be useful in conducting business and may help attract or retain management personnel, but there is room for abuse. What if the managers start spending more time at the golf course than at their desks? What if they use the company jets for personal travel? What if they buy company cars for their teenagers to drive? The abuse of perquisites imposes costs on the firm—and ultimately on the owners of the firm. There is also a possibility that managers who feel secure in their positions may not bother to expend their best efforts toward the business. This is referred to as shirking, and it too imposes a cost to the firm.

Finally, there is the possibility that managers will act in their own self-interest, rather than in the interest of the shareholders when those interests clash. For example, management may fight the acquisition of the company by some other firm even if the acquisition would benefit shareholders. Why? In most takeovers, the management personnel of the acquired firm generally lose their jobs. Envision that some company is making an offer to acquire the firm that you manage. Are you happy that the acquiring firm is offering the shareholders of your firm more for their stock than its current market value? If you are looking out for their best interests, you should be. Are you happy about the likely prospect of losing your job? Most likely not.

Many managers faced this dilemma in the merger mania of the 1980s. So what did they do? Among the many tactics,

- Some fought acquisition of their firms—which they labeled *hostile takeovers*—by proposing changes in the corporate charter or even lobbying for changes in state laws to discourage takeovers.⁸
- Some adopted lucrative executive compensation packages—called *golden parachutes*—that would go into effect if they lost their jobs.

⁸ A takeover offer not supported by the company’s board of directors is referred to as “hostile.” As G. William Schwert points out (“Hostility in Takeovers: In the Eyes of the Beholder,” *Journal of Finance* 55, 6 (December 2000), pp. 2599–2640), friendly and hostile takeovers are not different in economic terms, except that the bargaining process of hostile offers involves publicity.

Such defensiveness by corporate managers in the case of takeovers, whether it is warranted or not, emphasizes the potential for conflict between the interests of the owners and the interests of management.⁹ Antitakeover devices—also referred to as takeover defenses—are any type of tactic that is intended to discourage a takeover of a company. These devices are double-edged swords: They can be used to enhance the bargaining position of the target of a takeover or they can be motivated by management's self-interest. However, pressure from shareholders and the change in laws and regulations have reduced companies' use of takeover defenses and golden parachutes in recent years.¹⁰

Costs of the Agency Relationship

There are costs involved with any effort to minimize the potential for conflict between the principal's interest and the agent's interest. Such costs are called *agency costs*, and they are of three types: monitoring costs, bonding costs, and residual loss.

Monitoring costs are costs incurred by the principal to monitor or limit the actions of the agent. In a corporation, shareholders may require managers to periodically report on their activities via audited accounting statements that are sent to shareholders. The accountants' fees and the management time lost in preparing such statements are monitoring costs. Another example is the implicit cost incurred when shareholders limit the decision-making power of managers. By doing so, the owners may miss profitable investment opportunities; the forgone profit is a monitoring cost.

The board of directors of a corporation has a *fiduciary duty* to shareholders, that is, a legal responsibility to make decisions (or to see that decisions are made) that are in the best interests of shareholders. Part of that responsibility is to ensure that managerial decisions are also in the best interests of the shareholders. Therefore, at least part of the cost of having directors is a monitoring cost.

Bonding costs are incurred by agents to assure principals that they will act in the principals' best interest. The name comes from the agent's promise

⁹ Many companies have retreated from antitakeover devices in response to pressure from shareholders. In response to pressure for better corporate governance, many firms have terminated their poison pills (see Stephen Taub, "Few Refills on Poison-Pill Prescriptions," *CFO.com*, March 3, 2004). Another antitakeover measure, the staggered board of directors, is also becoming less popular (see Stephen Taub, "The Staggering of Staggered Boards," *CFO.com*, October 29, 2004).

¹⁰ The SEC disclosure rules, effective December 29, 2006, require companies to disclose more information about executive compensation, including information about severance benefits of executives ("Executive Compensation and Related Person Disclosure," Securities and Exchange Commission, Final Rule, RIN3235-A180).

or bond to take certain actions. A manager may enter into a contract that requires him or her to stay on with the firm even though another company acquires it; an implicit cost is then incurred by the manager, who forgoes other employment opportunities.

Even when monitoring and bonding devices are used, there may be some divergence between the interests of principals and those of agents. The resulting cost, called the *residual loss*, is the implicit cost that results because the principals' and the agents' interests cannot be perfectly aligned even when monitoring and bonding costs are incurred.

Agency Relationship and Capital Structure

As noted previously, a company that takes on debt may be making an effective use of free cash flows, hence reducing agency costs associated with the available free cash flow. Taking on additional debt also increases monitoring because creditors and rating agencies will be monitoring the ability of the company to pay its obligations. Therefore, taking on additional debt may enhance the value of the company by reducing agency costs, offsetting some of the effect on the value of the company of increasing financial risk.

Another agency issue that arises with regard to the use of debt to affect the value of the company is the use of debt as a takeover defense. A *takeover defense* is any mechanism that discourages or prevents a hostile takeover. By taking on additional debt, a company can make itself unattractive to potential suitors. Some companies borrow to repurchase their common shares, increasing financial leverage dramatically. Whether this is beneficial to the company depends on a number of factors, especially the motivation.¹¹ Most research into the effects of takeover defenses concludes that the use of takeover defenses may reduce the value of the company, especially if motivated by self-interest on the part of the target company's management.¹² Jandik

¹¹ The effect on the value of the company of a debt-financed buyback depends on the operating risk of the company, the repurchase method, and the capital structure prior to the buyback (see Jennifer Caplan, "Buybacks or Giveaways?" *CFO.com*, September 20, 2002).

¹² See, for example, Sidharth Sinha, "Share Repurchases as a Takeover Defense," *Journal of Financial and Quantitative Analysis* 26, 2 (June 1991), pp. 233–244] and Laura Casares Field and Jonathan M. Karpoff, "Takeover Defenses of IPO Firms," *Journal of Finance* 57, 5 (October 2002), pp. 1857–1889. Additionally, poor performing companies that increase debt in response to a takeover bid experience high management turnover, suggesting that shareholders respond to this action (see Assem Safieddine and Sheridan Titman, "Leverage and Corporate Performance: Evidence from Unsuccessful Takeovers," *Journal of Finance* 54, 2 (April 1999), pp. 547–580). Garvy and Hanka, in their study of the role of state antitakeover laws, find that companies protected by state antitakeover laws have lower debt levels than

and Makhija conclude in their study of unsuccessful takeovers that if the increase in debt results in better monitoring, such as that afforded by bank borrowing, the company benefits from the increase in debt; on the other hand, if the increase in debt results in management entrenchment, the effect on the value of the company is negative.¹³ In other words, the use of takeover defenses that are motivated by self-interest may impose a cost to owners.

OPTIMAL CAPITAL STRUCTURE: THEORY AND PRACTICE

The CFO can try to evaluate whether there is a capital structure that maximizes the value of the company. This capital structure, if it exists, is referred to as the *optimal capital structure*. However, even if the company's optimal capital structure cannot be determined precisely, the CFO should understand that there is an economic benefit from the tax deductibility of taxes, but eventually, this benefit may be reduced by the costs of financial distress.

So what good is this analysis of the trade-off between the value of the interest tax shields and the costs of distress if we cannot apply it to a specific company? While we cannot specify a company's optimal capital structure, we do know the factors that affect the optimum. The analysis demonstrates that there is a benefit from taxes and the discipline of debt but, eventually, these benefits reduce financial flexibility and may increase the likelihood of financial distress.

Benefits of debt financing

- Interest tax-shield
- Governance value

Costs of debt financing

- Financial flexibility
- Financial distress and/or bankruptcy

Capital Structures among Different Industries

The analysis of the capital structure trade-off suggests several financial characteristics of companies that affect the choice of capital structure:

- The greater the marginal tax rate, the greater the benefit from the interest deductibility and, hence, the more likely a company is to use debt in its capital structure.

firms not as well protected, suggesting that companies use debt as an antitakeover defense. (Gerald T. Garvy and Gordon Hanka, "Capital Structure and Corporate Control: The Effect of Antitakeover Statutes on Firm Leverage," *Journal of Finance* 54, 2 (April 1999), pp. 519–546.)

¹³ Tomas Jandik and Anil Makhija, "Debt, Debt Structure and Corporate Performance After Unsuccessful Takeovers: Evidence from Targets that Remain Independent," *Journal of Corporate Finance* 11 (2005), pp. 882–914.

- The greater the business risk of a company, the greater the present value of financial distress and, therefore, the less likely the company is to use debt in its capital structure.
- The greater extent that the value of the company depends on intangible assets, the less likely it is to use debt in its capital structure.

It is reasonable to expect these financial characteristics to differ among industries, but be similar within an industry. The marginal tax rate should be consistent within an industry since:

- The marginal tax rates are the same for all profitable companies.
- The tax law provides specific tax deductions and credits (for example, depreciation allowances and research and development credits) that create some differences across industries, but generally apply to all companies within an industry since the asset structure and the nature of investment is consistent within an industry.
- The companies in an industry are subject to the same economic and market forces that may cause tax shields to be unusable. Therefore, it is reasonable to assume that capital structures should be similar within industry groups.

Capital Structures within Industries

The capital structures among companies within industries differ for several possible reasons. First, within an industry there may not be a homogeneous group of companies. For example, Ben and Jerry's, Brach's Candy, and Sara Lee Corporation are all considered members of the food product industry, but they have quite different types of business risk. The problem of industry groupings is exacerbated by conglomeration, with many industries now including companies with dissimilar product lines.

Adding to the difficulty in comparing companies is the Financial Accounting Standards Board (FASB) requirement that companies consolidate the accounting data of majority-owned subsidiaries. The capital structure of the automobile manufacturers may look quite different when the financing subsidiaries are included in the calculation of their debt ratios.

Another reason an industry may appear to comprise companies having different capital structures is the way the debt ratio is calculated. We can see this in Figure 2.6, where the debt to market value of equity ratios are shown alongside the debt to book value of equity ratios for companies in the amusement industry.¹⁴ With book value of equity, the debt ratio ranges from

¹⁴ The book value of debt is used in the calculation of both ratios in the exhibit. This is necessitated by the lack of current market value data on long-term debt.

FIGURE 2.6 Capital Structure Ratios for Companies in the Confectionary Industry, 2005

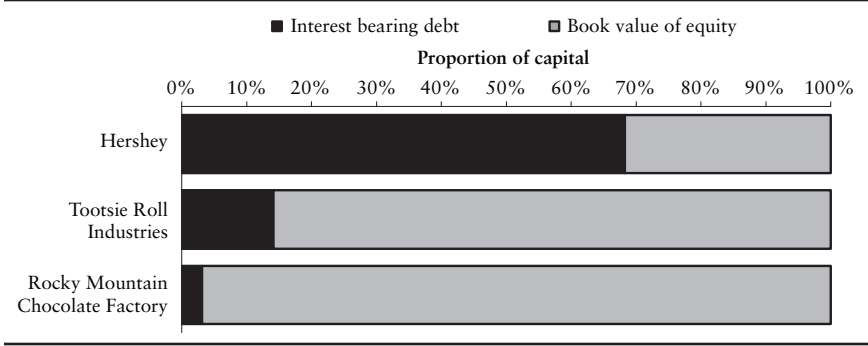

Panel A Interest-bearing debt and book value of equity capital components

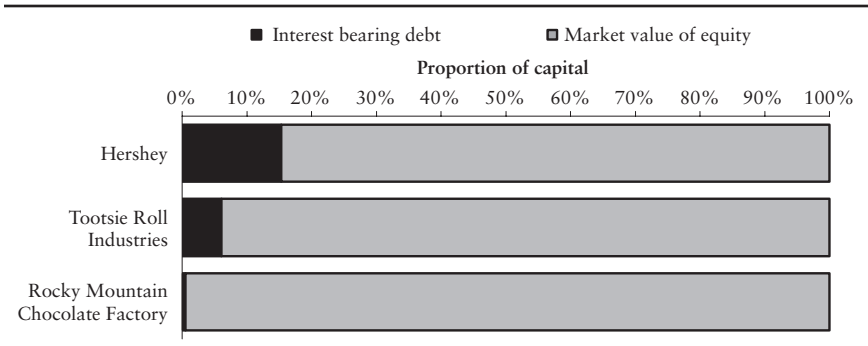

Panel B Interest-bearing debt and market value of equity capital components

Source of data: Financial statement data is from 10-K filings for the individual companies and the market value of a share of the companies' stock as of March 1, 2006 is taken from Yahoo! Finance.

1.405 to 34.432 times in the automotive industry, whereas the debt ratio using the market value of equity ranges from 0.106 to 15.677 times.

Trade-Off Theory and Observed Capital Structures

The trade-off theories can explain some of the capital structure variations that we observe. Companies whose value depends to a greater extent on intangibles, such as in the semiconductor and drug industries, tend to have lower debt ratios. Companies in volatile product markets, such as the electronics and telecommunications industries, tend to have lower debt ratios.

However, the trade-off theories cannot explain all observed capital structure behavior. We observe profitable companies in the drug manufac-

turing industry that have no long-term debt. Though these companies do have a large investment in intangibles, they choose not to take on *any* debt at all, even though taking on some debt could enhance the value of their companies.

We also see companies that have high business risk and high debt ratios. Companies in the air transportation industry experience a volatile product market, with a high degree of operating leverage. Companies in this industry must invest heavily in jets, airport gates, and reservations systems, and have a history of difficulty with labor. However, these companies also have high debt ratios, with upwards of 80% of their assets financed with debt. One possible explanation for airlines taking on a great deal of financial leverage on top of their already high operating leverage is that their assets, such as jets and gates, can be sold quickly, offsetting the effects of their greater volatility in operating earnings. Whereas the high business risk increases the probability of financial distress, the liquidity of their assets reduces the probability of distress. But hindsight tells us more about the airline industry. The overcapacity of the industry just prior to the recession of 1989–1991 meant that there wasn't much of a market for used jets and planes. The airlines suffered during this economic recession: Of the 14 companies in existence just prior to 1989, four companies entered bankruptcy (Continental, Pan Am, Midway, and America West), and two were liquidated (Eastern Airlines and Braniff).

Other Possible Explanations

Looking at the financing behavior of companies in conjunction with their dividend and investment opportunities, we can make several observations:

- Companies prefer using internally generated capital (retained earnings) to externally raised funds (issuing equity or debt).
- Companies try to avoid sudden changes in dividends.
- When internally generated funds are greater than needed for investment opportunities, companies pay off debt or invest in marketable securities.
- When internally generated funds are less than needed for investment opportunities, companies use existing cash balances or sell off marketable securities.
- If companies need to raise capital externally, they issue the safest security first; for example, debt is issued before preferred stock, which is issued before common equity.

The trade-off among taxes and the costs of financial distress leads to the belief that there is some optimal capital structure such that the value of the company is maximized. Yet, it is difficult to reconcile this with some observations in practice. Why?

One possible explanation is that the trade-off analysis is incomplete. We didn't consider the relative costs of raising funds from debt and equity. Because there are no out-of-pocket costs to raising internally generated funds (retained earnings), it may be preferred to debt and to externally raised funds. Because the cost of issuing debt is less than the cost of raising a similar amount from issuing common stock (typically flotation costs of 2.2% versus 7.1%), debt may be preferred to issuing stock.

Another explanation for the differences between what we observe and what we believe should exist is that companies may wish to build up financial slack, in the form of cash, marketable securities, or unused debt capacity, to avoid the high cost of issuing new equity.

Still another explanation is that CFOs may be concerned about the signal given to investors when equity is issued. It has been observed that the announcement of a new common stock issue is viewed as a negative signal, since the announcement is accompanied by a drop in the value of the equity of the company. It is also observed that the announcement of the issuance of debt does not affect the market value of equity. Therefore, the CFO must consider the effect that the new security announcement may have on the value of equity, and hence may shy away from issuing new equity.

The concern over the relative costs of debt and equity and the concern over the interpretation by investors of the announcement of equity financing lead to a preferred ordering, or *pecking order*, of sources of capital: first internal equity, then debt, then preferred stock, then external equity (new common stock). A result of this preferred ordering is that companies prefer to build up funds, in the form of cash and marketable securities, so as not to be forced to issue equity at times when internal equity (retained earnings) is inadequate to meet new profitable investment opportunities.¹⁵

A CAPITAL STRUCTURE PRESCRIPTION

The analysis of the trade-off and pecking order explanations of capital structure suggests that there is no satisfactory explanation. What the CFO can take from an examination of these possible explanations is that there are several factors to consider in making the capital structure decision:

¹⁵ For a more complete discussion of the pecking order explanation, especially the role of asymmetric information, see Stewart C. Myers, "The Capital Structure Puzzle," *Midland Corporate Finance Journal* 3, no. 3 (Fall 1985), pp. 65–76.

- *Taxes.* The tax deductibility of interest makes debt financing attractive. However, the benefit from debt financing is reduced if the company cannot use the tax shields.
- *Risk.* Because financial distress is costly, even without legal bankruptcy, the likelihood of financial distress depends on the business risk of the company, in addition to any risk from financial leverage.
- *Type of asset.* The cost of financial distress is likely to be more for companies whose value depends on intangible assets and growth opportunities.
- *Financial slack.* The availability of funds to take advantage of profitable investment opportunities is valuable. Therefore, having a store of cash, marketable securities, and unused debt capacity is valuable.

The CFO's task is to assess the business risk of the company, predicting the usability of tax deductions in the future, evaluating how asset values are affected in the event of distress, and estimating the relative issuance costs of the alternative sources of capital. In the context of all these considerations, the CFO can observe other companies in similar situations, using their decisions and consequences as a guide.

BOTTOM LINE

- The capital structure decision involves managing the risks associated with the company's business and financing decisions. The concept of leverage, operating and financial, plays a role in the company's risk because leverage exaggerates both favorable and unfavorable outcomes.
- Financial leverage is the use of fixed cost sources of funds. The effect of using financial leverage is to increase both the expected returns and the risk to owners.
- Taxes provide an incentive to take on debt, since interest paid on debt is a deductible expense for tax purposes, shielding income from taxation. But the possibility of incurring direct and indirect costs of financial distress discourages taking on high levels of debt.
- Taxes and financial distress costs result in a trade-off. For low debt ratios, the benefit of taxes more than overcomes the present value of the costs of financial distress, resulting in increases in the value of the company for increasing debt ratios. But beyond some debt ratio, the benefit of taxes is overcome by the costs of financial distress; the value of the company decreases as debt is increased beyond this point.

- An explanation for the capital structures that we observe is that companies prefer to raise capital internally, but will raise capital externally according to a pecking order from safe to riskier securities.
- In an agency relationship, the agent has the responsibility of acting for the principal. There is concern that management (the agent) will not act in the best interest of the shareholders (the principals).
- Agency costs are the costs associated with any effort to minimize the potential for conflict between the owners and management and include monitoring costs, bonding costs, and residual loss.
- An explanation for the capital structures that we observe is that firms prefer to raise capital internally, but will raise capital externally according to a pecking order from safe to riskier securities.
- The CFO may not be able to figure out the best capital structure for a company. However, a good checklist of factors to consider in the capital structure decision is: taxes, business risk, asset type, issuance costs, and investor interpretations of security issuance announcements.

APPENDIX: CAPITAL STRUCTURE THEORY— THE MODIGLIANI-MILLER THEORY AND BEYOND

The value of a firm—meaning the value of all its assets—is equal to the sum of its liabilities and its equity (the ownership interest). Does the way we finance the firm’s assets affect the value of the firm and hence the value of its owners’ equity? Yes. How does it affect the value of the firm? It depends as explained in this appendix.

M&M Irrelevance Proposition

Franco Modigliani and Merton Miller developed the basic framework for the analysis of capital structure and how taxes affect the value of the firm.¹⁶

¹⁶ The capital structure theory was set forth by Franco Modigliani and Merton H. Miller primarily in two articles. In “The Cost of Capital, Corporation Finance, and the Theory of Investment” (*American Economic Review* 48, no. 3 (June 1958), pp. 261–197), they focus on the theory before taxes are considered. The bottom line of this article was that what matters in the value of the firm is the firm’s operating cash flows and the uncertainty associated with these cash flows. The second article, “Corporate Income Taxes and the Cost of Capital: A Correction” (*American Economic Review* 53, no. 3 (June 1963), pp. 433–443), they introduce taxes into the theory. The bottom line of this second article is that when interest can be deducted in calculating taxable income, but dividends are not, the value of the firm is enhanced because of this tax deductibility of interest.

Modigliani and Miller (M&M) reasoned that if the following conditions hold, the value of the firm is not affected by its capital structure:

- Condition 1:* Individuals and corporations are able to borrow and lend at the same terms (referred to as “equal access”).
- Condition 2:* There is no tax advantage associated with debt financing vis-à-vis equity financing.
- Condition 3:* Debt and equity trade in a market where assets that are substitutes for one another trade at the same price.¹⁷

Under the first condition, individuals can borrow and lend on the same terms as the business entities. Therefore, if individuals are seeking a given level of risk, they can either: (1) borrow or lend on their own or (2) invest in a business that borrows or lends. In other words, if an individual investor wants to increase the risk of an investment, the investor could choose to invest in a firm that uses debt to finance its assets. Or, the individual could invest in a firm with no financial leverage and take out a personal loan—increasing the investor’s own financial leverage.

The second condition isolates the effect of financial leverage. If deducting interest from earnings is allowed in the analysis, it would be difficult to figure out what effect financial leverage itself has on the value of the firm.¹⁸

The third condition insures that assets are priced according to their risk and return characteristics.

Under these conditions, the value of a firm is the same, no matter how it chooses to finance itself. The *total* cash flows to owners and creditors is the same and the value of the firm is the present value of the firm’s operating cash flows *ad infinitum*. If cash flows are expected to be the same each year, the value of the firm is the present value of this perpetual stream of cash flows:

$$\text{Value of the firm} = \frac{\text{Cash flow per period}}{\text{Capitalization rate}}$$

The discount rate is referred to as the *capitalization rate*, which is the discount rate that translates future earnings into a current value. The capitalization rate reflects the uncertainty associated with the expected earnings in the future. The more uncertain the future earnings, the less a dollar of future income is worth today and, hence, the greater the capitalization rate. But the uncertainty regarding the cash flows generated by the assets is not affected by how the assets are financed if the three M&M conditions hold.

¹⁷ This is referred to as a *perfect market*. If assets are traded in a perfect market, assets with the same risk and return characteristics will trade at the same price.

¹⁸ M&M develop the framework without taxes and then examine the effect of taxes.

How the assets are financed affects the amount of cash flows each party—creditors and owners—receives.

M&M show that the discount rate for the cash flows to equity owners is higher when the firm uses debt. Specifically, they show that the discount rate of the cash flows to owners is equal to the discount rate of a firm with no financial leverage plus the compensation for bearing risk appropriate to the amount of debt in the capital structure.

The compensation for bearing risk, as reasoned by M&M, should be the risk premium weighted by the relative use of debt in the capital structure. The *risk premium* is the difference between the discount rate for the net income to owners and the discount rate on earnings to creditors (the interest), which is assumed to be risk-free. Interest is paid to creditors no matter how well or how poorly the firm is doing; hence, it is considered risk-free to creditors.

Let r_s represent the capitalization rate for the firm's operating cash flows, r_e represent the discount rate for risky cash flows to owners, r_d represent the discount rate for risk-free debt cash flows, and D and E , respectively, be the value of debt and equity in the firm's capital structure. The cost of capital for the firm as a whole is the weighted average of the costs of debt and equity:

$$r_s = \frac{D}{D+E} r_d + \frac{E}{D+E} r_e$$

As demonstrated by M&M, the discount rate that is applied to the cash flows to owners is the rate applied to the all-equity firm plus a premium for risk:¹⁹

$$r_e = r_s + \left[(r_s - r_d) \left(\frac{D}{E} \right) \right]$$

Therefore, the greater the use of debt, the greater the risk premium. For example, assume the value of a firm (debt plus equity) is \$100 million and that

$$\begin{aligned} r_s &= 8\% = 0.08 \\ r_d &= 5\% = 0.05 \\ D &= \$20 \text{ million} \\ E &= \$80 \text{ million} \end{aligned}$$

Therefore, the cost of equity (r_e) is

$$\begin{aligned} r_e &= 0.08 + \left[(0.08 - 0.05) \left(\frac{\$20,000,000}{\$80,000,000} \right) \right] \\ &= 0.0875 = 8.75\% \end{aligned}$$

¹⁹ This equation for r_e is developed by algebraically rearranging the weighted cost of capital formula to solve for r_e .

If more of the firm is financed by debt, say 40%, then

$$r_s = 8\% = 0.08$$

$$r_d = 5\% = 0.05$$

$$D = \$40 \text{ million}$$

$$E = \$60 \text{ million}$$

Therefore, the cost of equity (r_e) is

$$\begin{aligned} r_e &= 0.08 + \left[(0.08 - 0.05) \left(\frac{\$40,000,000}{\$60,000,000} \right) \right] \\ &= 0.10 = 10\% \end{aligned}$$

Consider a firm with expected annual cash flows of \$8 million per year, *ad infinitum*. Suppose that the appropriate discount rate for an all-equity firm, r_s , is 8%. The value of the firm is $\$8/0.08 = \100 million. If this firm has 20% debt in its capital structure with a cost of 5%, the debt cash flow is the interest of \$1 million. The cost of equity is 8.75% as computed above. So we have

| | Cash Flow in Millions | Cost of Capital | Value in Millions |
|--------|--------------------------|--------------------|----------------------|
| Debt | \$1 | 5.00% | \$20 |
| Equity | <u>7</u> | <u>8.75%</u> | <u>80</u> |
| Firm | \$8 | 8.00% | \$100 |

If this firm has 40% debt in its capital structure with a cost of 5%, the cost of equity is 10% as computed above and we have

| | Cash Flow in Millions | Cost of Capital | Value in Millions |
|--------|--------------------------|--------------------|----------------------|
| Debt | \$2 | 5% | \$40 |
| Equity | <u>6</u> | <u>10%</u> | <u>60</u> |
| Firm | \$8 | 8% | \$100 |

In other words, what we see from these two examples with two different capital structures is that when there are no taxes and no costs to financial distress, no matter how the cash flows are sliced, the value of the “pie” is \$100 million. As shown in Figure 2.7, the relation between the value of the firm and the proportion of debt in the capital structure is quite uninteresting.

If there are no taxes and no costs to financial distress, the choice of capital structure is irrelevant. The reasoning is simple:

FIGURE 2.7 Capital Structure Irrelevance When There Are No Tax Deductibility of Interest and No Costs of Financial Distress

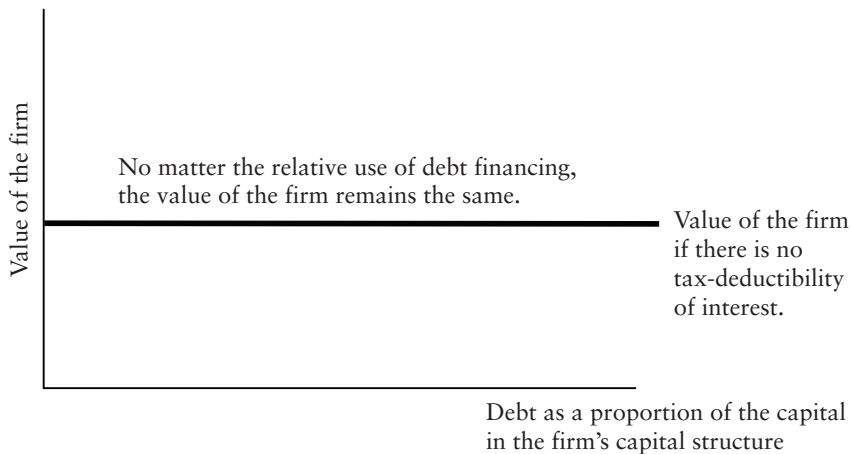

- The transactions involving the capital structure do not change total cash flows.
- It is the cash flows that are relevant to valuation. The value of the firm is determined by its operating assets.
- How the financial pie is divided among creditors and owners does not affect the total value.

Consider the view of investors. Investors do not pay more for the ownership of the firm that borrows if they could have borrowed as well. And because the value of the firm is the present value of cash flows, if there are no taxes, debt and equity choices should not affect the value of the firm.

M&M show that in the simplified world without taxes or costs of financial distress, the value of the firm depends on the cash flows of the firm, *not* on how the firm's cash flows are divided between creditors and owners. An implication of the M&M analysis is that the use of debt financing increases the risk of the future cash flows to owners and, hence, increases the discount rate investors use to value these future earnings (the cost of equity). They reason that the effect that the increased expected cash flows have on the value of equity is just offset by the increased discount rate applied to these riskier earnings, keeping the cost of capital the same no matter what the capital structure is.

M&M with Tax Deductibility of Interest Paid on Debt

When M&M introduce the tax deductibility of interest into the framework, the use of debt has a distinct advantage over financing with equity. The deductibility of interest represents a form of a government subsidy of financing activities; the government is sharing the firm's cost of debt. We have referred to the benefit from interest deductibility as the interest tax shield because the interest expense shields income from taxation. The tax shield from interest deductibility is the amount by which taxes are reduced by the deduction for interest.

How does this tax shield affect the value of the firm? The tax shield is valuable because it reduces the net income of the firm that is paid to the government in the form of taxes. In any given year, this is the product of the tax rate and the interest expense. If this tax shield is anticipated each year, *ad infinitum*, the value of this tax shield is equal to the marginal tax rate multiplied by the amount of the debt. That is, letting τ denote the marginal tax rate, then the value of the tax shield is τD .²⁰

Suppose that the firm has cash flows of \$8 million per year in perpetuity and the discount rate for this firm if all-equity financed is 8%. The value of the firm is \$100 based on these cash flows. Suppose instead that the firm is financed with \$20 million of debt and \$80 million of equity. If the interest rate on debt is 5%, then there is \$1 million per year in interest. If the marginal tax rate is 40%, the tax benefit is \$1 million \times 40% = \$0.4 million. In perpetuity, this interest cash flow stream has a value today of \$0.4 million/0.05 = \$8 million. The \$8 million is the value enhancement from the tax shield from debt.²¹

If we represent the value of the unlevered firm as V_U and the value of the levered firm as V_L , the value of this levered firm considering the benefit from taxes is therefore:

$$V_L = V_U + \tau D$$

and the cost of capital for the firm is adjusted for the deductibility of interest on debt, which lowers the firm's cost of debt:

$$r_s = \left(\frac{D}{D+E} r_d (1-\tau) \right) + \frac{E}{D+E} r_e$$

²⁰ If the interest on debt is $r_d D$, the tax shield is $\tau r_d D$. Capitalizing this at r_d , the value of the tax shield is $\tau r_d D / r_d = \tau D$.

²¹ As a practical matter, if a firm is *not* profitable, the tax shield is less valuable because the full value of the tax deductibility of interest cannot be realized. There are mechanisms, such as leasing, that the firm can use to capture part of the tax benefits.

Of the pie, the creditors' slice is \$20 million whereas the owners' slice is \$88 million as summarized below:²²

| | Cash Flow in Millions | Cost of Capital | Value in Millions |
|------------------------------------|--------------------------|--------------------|----------------------|
| Debt | \$1.00 | 5.00% | \$20.00 |
| Equity | | | |
| From residual operating cash flows | 7.00 | 8.75% | 80.00 |
| From tax shield | <u>0.40</u> | <u>5.00%</u> | <u>8.00</u> |
| Firm | \$8.00 | 7.60% | \$108.00 |

In other words, the pie has grown and the owners are the beneficiaries of the addition to the size of the pie from the tax deductibility of interest.

If there are no costs associated with financial distress:

- The value of the firm will increase with ever-increasing use of debt financing because of the value enhancement from the use of the interest tax shield.
- The cost of capital for the firm will decrease with ever-increasing use of debt financing because the after-tax cost of debt affects the cost of capital for the firm as a whole such that the increased use of the debt reduces the cost of capital.

This is depicted in Figure 2.8.

Is there a limit to how much debt can be used? As long as there are no costs to financial distress, the only limit is the existence of at least a small percentage of equity in the capital structure.²³

Capital Structure Theory and Costs of Financial Distress

If the debt burden is too much, the firm may experience financial distress, resulting in an increasing cost of capital: At some point, the value of the

²² In this example with 20% debt, the value of debt is \$20, the value of equity without considering the value of the tax shield is $\$7 \text{ million} / 0.0875 = \80 million , and the value of the tax shield, which accrues to the owners, is $\$0.4 \text{ million} / 0.05 = \8 million .

²³ At 100% debt financing, creditors would be, in effect, owners and hence the capital structure would be all equity once again. We generally think of the limit as some extreme, such as 99.9% debt. However, there are "thin capitalization rules," described in Chapter 7, that prohibit an extremely large amount of debt relative to equity and can result in the government reclassifying debt as equity and thereby reclassifying interest payments as dividend payments.

FIGURE 2.8 Capital Structure Irrelevance When There Is Tax Deductibility of Interest, but No Costs of Financial Distress

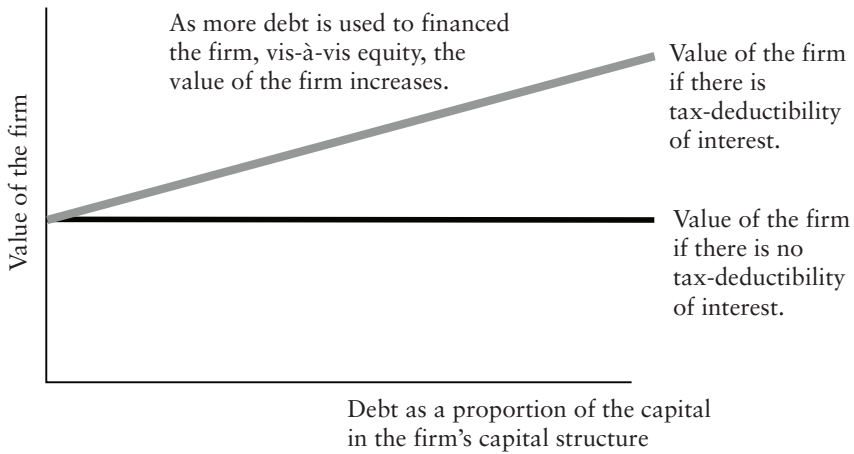

Panel A Value of the firm

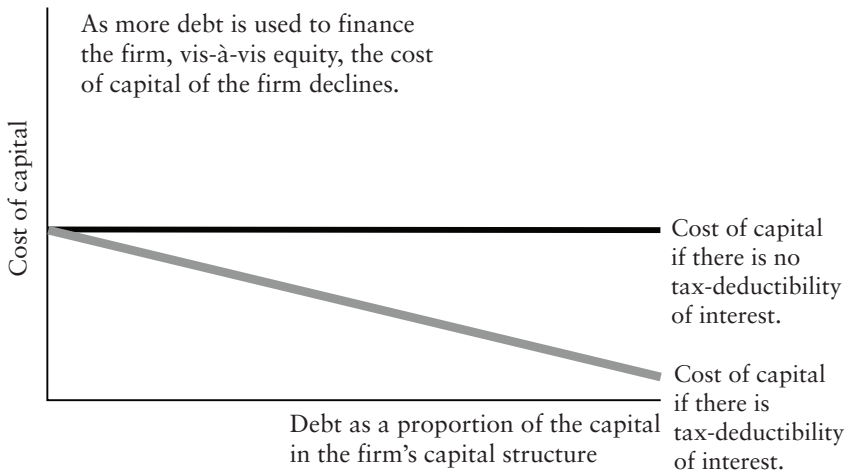

Panel B Cost of capital

firm declines and the cost of capital increases with increasing use of debt financing. Financial distress results in both direct and indirect costs including, for example, legal costs, opportunity costs for projects, and the effect on the relationship with customers and suppliers.

At some capital structure, these costs begin to offset the benefit of the interest deductibility of debt. The optimal capital structure is the point at which the value of the firm is maximized. Up until the optimal capital structure, the benefits from the tax deductibility of interest outweigh the costs of financial distress. When the amount of financial leverage exceeds the optimal capital structure, the benefits from the tax deductibility of interest are outweighed by the cost of financial distress. This is shown in Figure 2.9.

FIGURE 2.9 Capital Structure Irrelevance When There Are Tax Deductibility of Interest and Costs of Financial Distress

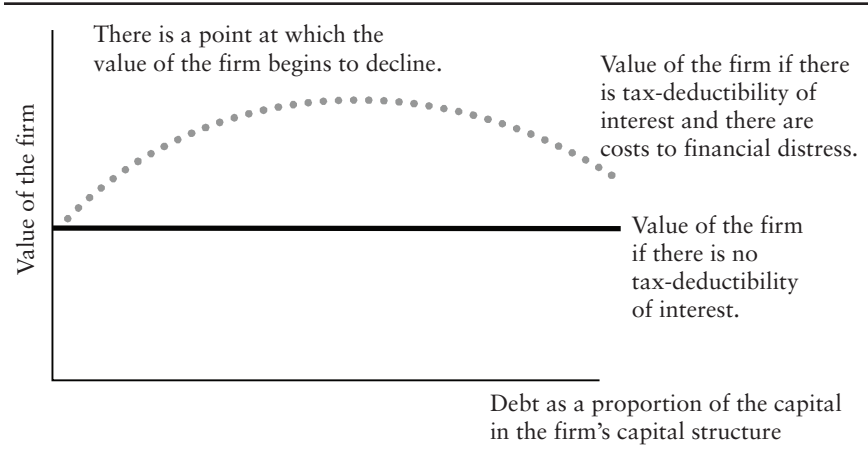

Panel A Value of the firm

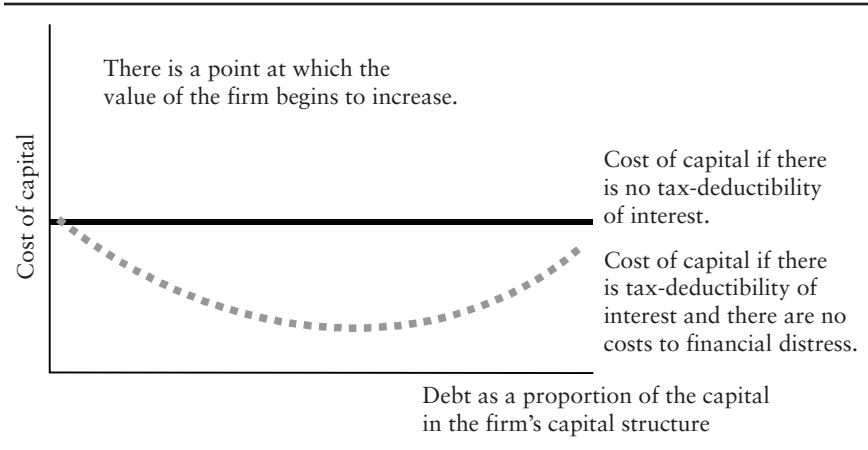

Panel B Cost of capital

Because of the relation between the value of the firm and the cost of capital, the capital structure that maximizes the value of the firm is the same capital structure that minimizes the cost of capital.

The problem is that we cannot determine beforehand what the optimal capital structure is for a given firm. The theory is not prescriptive in terms of identifying this precise point. What we can observe is when a firm takes on too much debt and distress occurs. The optimal capital structure depends, in large part, on the business risk of the company: The greater the business risk of the company, the sooner this optimal capital structure is reached.

So what good is the theory of capital structure if a CFO cannot determine the optimal capital structure? The M&M theory, along with subsequent related theories and evidence, provides a framework for the CFO:

- There is a benefit to taking on debt—to a point.
- The cost of capital of a firm will decrease with ever-increasing use of debt financing—to a point.
- The optimal capital structure depends on the risk associated with the firm's operating cash flows.

Types of Debt Financing

AGENDA

- Item 1* Explain what a debt obligation is.
- Item 2* Describe the general features of debt obligations.
- Item 3* Explain what a term loan is and the features of a term loan.
- Item 4* Explain what a syndicated bank loan is.
- Item 5* Discuss the features of a corporate note/bond (denomination, term to maturity, interest rate, security, seniority, provisions for retirement of debt, and convertibility) and how they are issued.
- Item 6* Explain the factors a CFO considers in designing a bond issue.
- Item 7* Distinguish between a corporate bond and a medium-term note.
- Item 8* Identify the different forms of short-term financing.
- Item 9* Explain what off-balance-sheet financing is and how such transactions are handled for financial and SEC reporting.

In a debt financing, a corporation receives money in exchange for a promise to repay the lender (creditor) the amount borrowed at some future time. We refer to the indebtedness between a corporation and a lender as a *loan*. If the borrower issues a security to represent the indebtedness, we usually refer to the securities issued as notes and bonds.

The cost of debt arrangements is not simply the interest rate on the borrowed funds. There are fees that typically have to be paid. In the case of loans, this might include commitment fees. In the issuance of notes or bonds, the fees would include legal fees, the cost of registering the securities with the Securities and Exchange Commission (SEC), and the spread charged by investment bankers in distributing the issue. The cost of debt instruments after taking into account the interest and any fees is referred to as the *all-in-cost of debt*.

In this chapter, we discuss the features of debt instruments, focusing on two specific types of debt—loans and notes/bonds. We describe these debt instruments by focusing on the different features, such as interest rate and maturity. From the perspective of the investor, these features affect the pattern of cash flows from the investment and the uncertainty associated with

these cash flows, both of which affect the cost of debt capital to the firm. From the perspective of the issuer, the key is to package these features in a debt obligation in a way to make them attractive to investors, provide reasonable cost of debt to the issuer, and to give the firm flexibility to alter its capital structure in the future. Short-term debt obligations (meaning repayment within one year) are discussed in the last part of this chapter. Other forms of borrowing via structured financing transactions, are the subject of the next chapter.

GENERAL FEATURES OF DEBT OBLIGATIONS

The amount borrowed is called the *principal* and is repaid either at the end of the period of indebtedness or at regular intervals during this period. When the entire principal is repaid only at the end of the period of the indebtedness, the debt obligation is said to have a *bullet structure*. If, instead, the principal payments are made over time based on a schedule, the debt obligation is said to have an *amortizing structure*.

The lender receives *interest* to compensate for lending funds. For some types of debt the interest is paid periodically, and for other types is paid at the end of the debt period. The interest rate can be a fixed rate or a variable rate. When the interest rate is a variable rate, more popularly referred to as a *floating rate*, there is a formula that sets forth how the interest rate on the debt obligation will be determined at the interest reset date. The formula is called the *interest rate reset formula*. The general formula is:

$$\text{Floating rate} = \text{Reference rate} + \text{Quoted margin}$$

The *reference rate* is the interest rate on some specified market interest rate or some other benchmark. The *quoted margin* is fixed over the life of the debt obligation. The amount of the quoted margin depends on the credit quality of the borrower and other features of the debt obligation. The lower the credit quality of the borrower, the higher the quoted margin. The date on which the rate on the debt obligation is changed is called the *reset date*. The period over which the new rate applies is called the *reset period*. For example, suppose that a debt obligation's reset period is three months and the reference rate is the 3-month London interbank offered rate (LIBOR). Suppose further that the quoted margin is 150 basis points. That is, the formula for its floating rate is 3-month LIBOR + 150 basis points. So, if 3-month LIBOR at a reset date is 5%, then the interest rate for the reset period would be 6.5%.

A floating-rate debt obligation can have a maximum interest rate imposed. This means that if the interest rate reset formula at a reset date indicates that the interest rate is greater than the maximum interest rate specified, the for-

mula is overridden. The maximum interest rate in a floating-rate debt obligation is referred to as a *cap*. A cap is an advantage to the borrower and a disadvantage to the lender. There are some floating-rate debt obligations that set a minimum interest rate. The minimum interest rate is called a *floor*. The floor is an advantage to the lender and a disadvantage to the borrower.

The lender cannot be absolutely sure that the borrower will repay the principal and pay the interest when promised. Realizing that, borrowers typically specify this assurance in the form of a promise to repay with property they own, if necessary. Failing to pay when promised, the creditors force the sale of this property to be repaid from the proceeds. Debt backed by property is referred to as *secured debt* and to property is referred to as *security* or *collateral*. If there is no security, the creditor relies entirely on the ability of the borrower to make the promised payments and this type of debt is referred to as *unsecured*.

TERM LOANS

Term loans are negotiated directly between borrower and creditor, where the creditor is typically a commercial bank, an insurance company, or a finance company. Term loans range in maturity from two to ten years, though any repayment term is possible. These debts are referred to as term loans because there is a fixed term, or fixed maturity, for the loan, as opposed to a loan that is payable on demand. Term loans can be secured or unsecured. The interest rate on term loans is usually variable, although some lenders offer a fixed rate.

Term loans are usually repaid in installments either monthly, quarterly, semiannually, or annually. In a typical term loan, the payments are structured such that each payment will include interest and principal repayment. A loan structured in this way is what we refer to as an *amortizing loan*. The loan payments are determined such that after the last payment is made, there is no loan balance outstanding. Thus the loan is referred to as a *fully amortizing loan*.

To illustrate a term loan, suppose that a corporation seeks a 4-year term loan of \$100 million. Let's assume for now that the term loan carries a fixed interest rate of 8% and that level payments are made monthly. For this hypothetical 4-year, \$100 million term loan, the monthly payment would be \$2,441,292.23. This amount is determined by using the time value of money principles.¹ Table 3.1 shows for each month the amount of the

¹ The procedure is to determine the amount of an annuity (i.e., the monthly loan payment) that will make the present value of 48 payments of the annuity equal to \$100 million using a discount rate of 0.66667%. The 0.66667% discount rate is the annual interest rate of 8% divided by 12 since the loan repays monthly.

TABLE 3.1 Term Loan Amortization Schedule: Fixed Rate, Fully Amortized

Amount of monthly payment for the loan

| | |
|-----------------------|----------------|
| Annual interest rate | 8% |
| Monthly interest rate | 0.6667% |
| Number of months | 48 |
| Loan | \$100,000,000 |
| Balloon payment | 0 |
| Monthly payment | \$2,441,292.23 |

| Month | Beginning Loan Balance | Interest | Scheduled Principal Repayment | Ending Loan Balance |
|-------|------------------------|--------------|-------------------------------|---------------------|
| 1 | \$100,000,000.00 | \$666,666.67 | \$1,774,625.57 | \$98,225,374.43 |
| 2 | 98,225,374.43 | 654,835.83 | 1,786,456.40 | 96,438,918.03 |
| 3 | 96,438,918.03 | 642,926.12 | 1,798,366.11 | 94,640,551.91 |
| 4 | 94,640,551.91 | 630,937.01 | 1,810,355.22 | 92,830,196.69 |
| 5 | 92,830,196.69 | 618,867.98 | 1,822,424.26 | 91,007,772.44 |
| 6 | 91,007,772.44 | 606,718.48 | 1,834,573.75 | 89,173,198.69 |
| 7 | 89,173,198.69 | 594,487.99 | 1,846,804.24 | 87,326,394.44 |
| 8 | 87,326,394.44 | 582,175.96 | 1,859,116.27 | 85,467,278.17 |
| 9 | 85,467,278.17 | 569,781.85 | 1,871,510.38 | 83,595,767.79 |
| 10 | 83,595,767.79 | 557,305.12 | 1,883,987.12 | 81,711,780.68 |
| 11 | 81,711,780.68 | 544,745.20 | 1,896,547.03 | 79,815,233.65 |
| 12 | 79,815,233.65 | 532,101.56 | 1,909,190.68 | 77,906,042.97 |
| 13 | 77,906,042.97 | 519,373.62 | 1,921,918.61 | 75,984,124.36 |
| 14 | 75,984,124.36 | 506,560.83 | 1,934,731.41 | 74,049,392.95 |
| 15 | 74,049,392.95 | 493,662.62 | 1,947,629.61 | 72,101,763.34 |

beginning monthly balance, the interest payment for the month, the amount of the monthly payment applied to repayment of the principal (referred to as the *scheduled principal repayment* or the *amortization*), and the ending loan balance. A schedule such as that shown in Table 3.1 is referred to as an *amortization schedule*. Notice that in our illustration, the ending loan balance is zero.

If instead of fully amortized, the scheduled payments by the borrower are insufficient to pay off the entire loan balance, the final payment necessary to pay of the outstanding loan balance is referred to as a *balloon payment*. In an *interest-only loan*, no scheduled principal repayment is made prior to the loan's maturity date. Only interest payments are made periodically. A loan structured in this way where no principal repayments are made during the life of the loan is called a *bullet loan* and the last payment is called a *bullet payment*.

TABLE 3.1 (Continued)

| Month | Beginning Loan Balance | Interest | Scheduled Principal Repayment | Ending Loan Balance |
|-------|------------------------|------------|-------------------------------|---------------------|
| 16 | 72,101,763.34 | 480,678.42 | 1,960,613.81 | 70,141,149.52 |
| 17 | 70,141,149.52 | 467,607.66 | 1,973,684.57 | 68,167,464.95 |
| 18 | 68,167,464.95 | 454,449.77 | 1,986,842.47 | 66,180,622.49 |
| 19 | 66,180,622.49 | 441,204.15 | 2,000,088.08 | 64,180,534.40 |
| 20 | 64,180,534.40 | 427,870.23 | 2,013,422.00 | 62,167,112.40 |
| 21 | 62,167,112.40 | 414,447.42 | 2,026,844.82 | 60,140,267.58 |
| 22 | 60,140,267.58 | 400,935.12 | 2,040,357.12 | 58,099,910.46 |
| 23 | 58,099,910.46 | 387,332.74 | 2,053,959.50 | 56,045,950.96 |
| 24 | 56,045,950.96 | 373,639.67 | 2,067,652.56 | 53,978,298.40 |
| 25 | 53,978,298.40 | 359,855.32 | 2,081,436.91 | 51,896,861.49 |
| 26 | 51,896,861.49 | 345,979.08 | 2,095,313.16 | 49,801,548.33 |
| 27 | 49,801,548.33 | 332,010.32 | 2,109,281.91 | 47,692,266.42 |
| 28 | 47,692,266.42 | 317,948.44 | 2,123,343.79 | 45,568,922.63 |
| 29 | 45,568,922.63 | 303,792.82 | 2,137,499.42 | 43,431,423.21 |
| 30 | 43,431,423.21 | 289,542.82 | 2,151,749.41 | 41,279,673.80 |
| 31 | 41,279,673.80 | 275,197.83 | 2,166,094.41 | 39,113,579.39 |
| 32 | 39,113,579.39 | 260,757.20 | 2,180,535.04 | 36,933,044.35 |
| 33 | 36,933,044.35 | 246,220.30 | 2,195,071.94 | 34,737,972.42 |
| 34 | 34,737,972.42 | 231,586.48 | 2,209,705.75 | 32,528,266.66 |
| 35 | 32,528,266.66 | 216,855.11 | 2,224,437.12 | 30,303,829.54 |
| 36 | 30,303,829.54 | 202,025.53 | 2,239,266.70 | 28,064,562.84 |
| 37 | 28,064,562.84 | 187,097.09 | 2,254,195.15 | 25,810,367.69 |
| 38 | 25,810,367.69 | 172,069.12 | 2,269,223.12 | 23,541,144.57 |
| 39 | 23,541,144.57 | 156,940.96 | 2,284,351.27 | 21,256,793.30 |
| 40 | 21,256,793.30 | 141,711.96 | 2,299,580.28 | 18,957,213.02 |
| 41 | 18,957,213.02 | 126,381.42 | 2,314,910.81 | 16,642,302.21 |
| 42 | 16,642,302.21 | 110,948.68 | 2,330,343.55 | 14,311,958.66 |
| 43 | 14,311,958.66 | 95,413.06 | 2,345,879.18 | 11,966,079.48 |
| 44 | 11,966,079.48 | 79,773.86 | 2,361,518.37 | 9,604,561.11 |
| 45 | 9,604,561.11 | 64,030.41 | 2,377,261.83 | 7,227,299.28 |
| 46 | 7,227,299.28 | 48,182.00 | 2,393,110.24 | 4,834,189.04 |
| 47 | 4,834,189.04 | 32,227.93 | 2,409,064.31 | 2,425,124.74 |
| 48 | 2,425,124.74 | 16,167.50 | 2,425,124.74 | 0.00 |

So far we have looked at a fixed-rate term loan. Suppose that the loan is a floating-rate loan and the loan resets at the beginning of each one-year anniversary of the loan. Specifically, let's assume that for the first year the loan rate is 8% and in the second year the loan rate increases to 10%. The monthly loan payment for the second year would be determined as follows. Assuming the loan is a fully amortizing loan, at the end of the first year we know what the outstanding loan balance is. This amount can be found in Table 3.1. It is \$77,906,042.97. Thus, the corporation is borrowing \$77,906,042.97 for three years at the new rate, 10% per annum or 0.8333% per month. The monthly loan payment to fully amortize a 3-year 10% term loan is \$2,513,808.87. Panel A in Table 3.2 shows the amortization schedule for the 12 months in the second year on the loan.

Let's suppose in the third year of the term loan that the loan rate decreases to 9%. The loan balance at the end of the second year is \$54,476,387.15 as can be seen from panel A in Table 3.2. The monthly loan payment to fully

TABLE 3.2 Amortization Schedule for a Term Loan with a Floating Rate: Years 2 through 4

| Amount of monthly payment for the loan | | | | |
|--|------------------------|--------------|--------------------------|---------------------|
| Annual interest rate | 10% | | | |
| Monthly interest rate | 0.8333% | | | |
| Number of months | 36 | | | |
| Loan | \$77,906,043 | | | |
| Monthly payment | \$2,513,808.87 | | | |
| Month | Beginning Loan Balance | Interest | Scheduled Loan Repayment | Ending Loan Balance |
| 1 | \$77,906,042.97 | \$649,217.02 | \$1,864,591.85 | \$76,041,451.12 |
| 2 | 76,041,451.12 | 633,678.76 | 1,880,130.11 | 74,161,321.01 |
| 3 | 74,161,321.01 | 618,011.01 | 1,895,797.86 | 72,265,523.15 |
| 4 | 72,265,523.15 | 602,212.69 | 1,911,596.18 | 70,353,926.97 |
| 5 | 70,353,926.97 | 586,282.72 | 1,927,526.15 | 68,426,400.82 |
| 6 | 68,426,400.82 | 570,220.01 | 1,943,588.87 | 66,482,811.95 |
| 7 | 66,482,811.95 | 554,023.43 | 1,959,785.44 | 64,523,026.52 |
| 8 | 64,523,026.52 | 537,691.89 | 1,976,116.98 | 62,546,909.53 |
| 9 | 62,546,909.53 | 521,224.25 | 1,992,584.63 | 60,554,324.91 |
| 10 | 60,554,324.91 | 504,619.37 | 2,009,189.50 | 58,545,135.41 |
| 11 | 58,545,135.41 | 487,876.13 | 2,025,932.74 | 56,519,202.66 |
| 12 | 56,519,202.66 | 470,993.36 | 2,042,815.52 | 54,476,387.15 |

Panel A Year 2

TABLE 3.2 (Continued)**Amount of monthly payment for the loan**

| | |
|-----------------------|----------------|
| Annual interest rate | 9% |
| Monthly interest rate | 0.7500% |
| Number of months | 24 |
| Loan | \$54,476,387 |
| Monthly payment | \$2,488,739.71 |

| Month | Beginning Loan Balance | Interest | Scheduled Loan Repayment | Ending Loan Balance |
|-------|------------------------|--------------|--------------------------|---------------------|
| 1 | \$54,476,387.15 | \$408,572.90 | \$2,080,166.80 | \$52,396,220.34 |
| 2 | 52,396,220.34 | 392,971.65 | 2,095,768.05 | 50,300,452.29 |
| 3 | 50,300,452.29 | 377,253.39 | 2,111,486.31 | 48,188,965.97 |
| 4 | 48,188,965.97 | 361,417.24 | 2,127,322.46 | 46,061,643.51 |
| 5 | 46,061,643.51 | 345,462.33 | 2,143,277.38 | 43,918,366.13 |
| 6 | 43,918,366.13 | 329,387.75 | 2,159,351.96 | 41,759,014.17 |
| 7 | 41,759,014.17 | 313,192.61 | 2,175,547.10 | 39,583,467.07 |
| 8 | 39,583,467.07 | 296,876.00 | 2,191,863.70 | 37,391,603.37 |
| 9 | 37,391,603.37 | 280,437.03 | 2,208,302.68 | 35,183,300.68 |
| 10 | 35,183,300.68 | 263,874.76 | 2,224,864.95 | 32,958,435.73 |
| 11 | 32,958,435.73 | 247,188.27 | 2,241,551.44 | 30,716,884.29 |
| 12 | 30,716,884.29 | 230,376.63 | 2,258,363.07 | 28,458,521.22 |

Panel B Year 3

amortize \$54,476,387.15 for 2 years at 9% is \$2,488,739.71. The amortization schedule for the third year is shown in panel B of Table 3.2. At the end of the third year, the outstanding balance is \$28,458,521.22. If in the fourth year, the loan rate decreases to 7.8%, then the monthly loan payment necessary to fully amortize \$28,458,521.22 for one year is \$2,472,931.18. Panel C of Table 3.2 shows the amortization schedule for the last year. Note that at the end of the fourth year the outstanding balance is zero; that is, the loan is fully amortized.

SYNDICATED BANK LOANS

A *syndicated bank loan* is one in which a group of banks provides funds to the borrower. The need for a group of banks arises because the amount sought by a borrower may be too large for any one bank to be exposed to the credit risk of that borrower. Therefore, the syndicated bank loan market

TABLE 3.2 (Continued)

| Amount of monthly payment for the loan | | | | |
|--|----------------|--|--|--|
| Annual interest rate | 7.8% | | | |
| Monthly interest rate | 0.6500% | | | |
| Number of months | 12 | | | |
| Loan | \$28,458,521 | | | |
| Balloon payment | 0 | | | |
| Monthly payment | \$2,472,931.18 | | | |

| Month | Beginning Loan Balance | Interest | Scheduled Loan Repayment | Ending Loan Balance |
|-------|------------------------|--------------|--------------------------|---------------------|
| 1 | \$28,458,521.22 | \$184,980.39 | \$2,287,950.80 | \$26,170,570.42 |
| 2 | 26,170,570.42 | 170,108.71 | 2,302,822.48 | 23,867,747.95 |
| 3 | 23,867,747.95 | 155,140.36 | 2,317,790.82 | 21,549,957.13 |
| 4 | 21,549,957.13 | 140,074.72 | 2,332,856.46 | 19,217,100.67 |
| 5 | 19,217,100.67 | 124,911.15 | 2,348,020.03 | 16,869,080.64 |
| 6 | 16,869,080.64 | 109,649.02 | 2,363,282.16 | 14,505,798.48 |
| 7 | 14,505,798.48 | 94,287.69 | 2,378,643.49 | 12,127,154.98 |
| 8 | 12,127,154.98 | 78,826.51 | 2,394,104.68 | 9,733,050.31 |
| 9 | 9,733,050.31 | 63,264.83 | 2,409,666.36 | 7,323,383.95 |
| 10 | 7,323,383.95 | 47,602.00 | 2,425,329.19 | 4,898,054.76 |
| 11 | 4,898,054.76 | 31,837.36 | 2,441,093.83 | 2,456,960.94 |
| 12 | 2,456,960.94 | 15,970.25 | 2,456,960.94 | 0.00 |

Panel C Year 4

is used by borrowers who seek to raise a large amount of funds in the loan market rather than through the issuance of securities. A syndicated loan is arranged by either a bank or a securities house, with a single loan agreement. The arranger then lines up the syndicate. Each bank in the syndicate provides the funds for which it has committed and therefore has a separate claim on a portion of the loan. The banks in the syndicate have the right to sell their parts of the loan subsequently to other banks.

These bank loans are called *senior bank loans* because they have a priority position over subordinated lenders (bondholders) with respect to repayment of interest and principal. The interest rate on a syndicated bank loan is a floating rate. The reference rate is typically LIBOR, although it could be the prime rate (that is, the rate that a bank charges its most creditworthy customers) or the rate on certificates of deposits.

The term of the loan is fixed. A syndicated loan is typically structured so that it is amortized according to a predetermined schedule, and repayment

of principal begins after a specified number of years (typically not longer than five or six years). Structures in which no repayment of the principal is made until the maturity date, that is, bullet loans, can be arranged.

NOTES AND BONDS

A firm may borrow money by issuing notes or bonds. Both are *certificates of indebtedness*, which are written obligations of the borrower to repay the amount borrowed under specified terms. There is a technical difference between a note and a bond. A bond has an *indenture agreement*, a note does not. An indenture agreement spells out the rights and duties of the borrower, with a trustee appointed to look out for the bondholders' interests. Though both a note and a bond are represented by legal contracts stipulating the rights and duties of the borrower, the contract representing a note is typically considered an agreement that is less formal than a bond's contract, and is not referred to as an indenture (see below). Throughout this chapter, we will use the terms *note* and *bond* interchangeably, with a preference for the term *bond*.

Because a bond is a contract between issuer and bondholders that obligates the issuer to pay the interest and principal and to abide by other terms as well, the rights of the bondholders and the obligations of the issuer must be specified. These obligations and rights are spelled out in the *indenture*. The indenture contains: (1) remedies, such as the ability to dispose of equipment or other property, in case the borrower fails to live up to provisions of the bond agreement; (2) the issuer's responsibilities to keep the bondholders informed regarding its financial condition; and (3) covenants. *Covenants* are provisions that limit or restrict the issuer's activities to insure sufficient funds are available to pay the debt's obligations. A covenant's typical provisions require the issuer to: pay interest and principal as specified; pay any real estate taxes on any secured property; and provide adequate insurance coverage on any secured property. In addition, a covenant may specify a minimum amount of working capital or restrictions on the payment of dividends. Each bond issue by a corporation may have a separate indenture, or the firm may have a blanket indenture covering all its bond issues. Several debt issues covered under the same indenture are referred to as a "series," and each issue within the series is usually labeled A, B, C, and so on.

Issuance of New Bonds

A U.S. corporation can issue bonds anywhere in the world. Bonds issued in the United States must comply with U.S. securities laws as regulated by the

SEC. *SEC Rule 415* permits certain issuers to file a single registration document indicating that they intend to sell a certain amount of a certain class of securities at one or more times within the next two years. This rule is popularly referred to as the *shelf registration rule* because the securities can be viewed as sitting on a shelf, and can be taken off that shelf and sold to the public without obtaining additional SEC approval. By allowing firms to file a single registration document, corporations can come to market quickly because the sale of the security has been preapproved by the SEC.

A new bond offering can be distributed to the public or privately placed with a limited number of institutional investors such as life insurance companies, investment companies, and pension funds. This distribution of a bond in this manner is referred to as a *private placement* and it differs from the public offering of a new bond issue. There is a difference in the regulatory requirements for a public and private sale of bonds. Securities law mandates that all securities offered to the general public must be registered with the SEC, unless there is a specific exemption. There are three exemptions from federal registration. First, intrastate offerings are exempt. Second, there is a small-offering exemption as specified by Regulation A, which exempts the sale of new securities for \$1 million or less. The third exemption is for “transactions by an issuer not involving any public offering.”

Securities law does not provide specific guidelines to label what is a private offering or placement. However, Regulation D provides guidelines that determine if an issue is qualified for exemption from registration. According to the guidelines, the securities cannot be offered through any form of general advertising or general solicitation that would prevail for public offerings. Moreover, the guidelines restrict the sale of securities to “sophisticated” investors. Such “accredited” investors are defined as those who (1) have the capability to evaluate (or can afford to employ an adviser to evaluate) the risk and return characteristics of the securities, and (2) have the resources to bear the economic risks.²

A restriction imposed on buyers of privately placed securities is that they may not be resold for two years after acquisition. Investors will require compensation for the lack of liquidity in the form of a higher interest rate. *SEC Rule 144A* eliminates the two-year holding period by permitting large institutions to trade securities acquired in a private placement among themselves without having to register these securities with the SEC. Private placements are now classified as Rule 144A offerings or non-Rule 144A offerings (i.e., traditional private placements).

A bond issued outside the United States need only comply with the securities laws of the countries where the securities are issued and traded.

² Under the current law, an accredited investor is one who satisfies a net worth test or an annual income test.

Eurobonds refer to indebtedness issued and traded in markets other than the currency in which the debts are denominated.

Investment bankers are typically involved in the issuance of bonds in one or more of the following three ways. First, they may advise the CFO on the terms and the timing of the offering. In an advisory capacity, investment bankers may be asked to design a security structure that is more attractive to investors than a particular traditional instrument in order to reduce the all-cost of the bond issue.

Second, they may purchase the bonds from the issuing corporation. The buying of a bond issue from the issuer is called *underwriting* and when an investment banking firm does so, it is said the investment banking firm is the *underwriter* because it accepts the risk of selling the bonds to investors at a lower price than for which it paid. This type of arrangement is referred to as a *firm commitment*. In contrast, in a *best efforts* arrangement, the investment banking firm does not purchase the issue from the issuer. Rather, it agrees to use its expertise only to sell the bonds.

There are variations in the underwriting process. One is the *bought deal*. In this arrangement, the lead manager or a group of managers offer the CFO of a potential issuing corporation a firm bid to purchase a specified amount of the issue with a certain interest rate and maturity. The CFO is given a day or so (maybe even only a few hours) to accept or reject the bid. If the bid is accepted, the underwriting firm has “bought the deal.” It can, in turn, sell the bonds to other investment banking firms for distribution to their clients and/or distribute the bonds to its clients. Typically, the investment banking firm that buys the bonds will have presold most of the bond issue to its institutional clients. The auction process is another variation for issuing bonds. In this arrangement, referred to as *competitive bidding underwriting*, the CFO announces the terms of the issue, and interested parties submit bids for the entire issue.

Third, investment bankers may distribute the bond issue to the public or place the bonds privately with some institutional investors. The fee that the investment banking firm earns from selling bonds is the difference between the price paid to the issuer and the price at which the investment bank reoffers the bonds to the public. This difference is called the *gross spread*.

Features and Provisions of a Bond Issue

The basic features or provisions of a bond issue include: (1) denomination, (2) term to maturity, (3) interest rate, (4) security, (5) seniority, and (6) provisions for retirement of debt.

Denomination

Most bonds sold in the United States are denominated in U.S. dollars—the interest and principal are paid in U.S. dollars. But it is possible to denominate bonds in any currency. A firm can borrow funds today outside the United States and promise to pay a specified interest and principal in a currency other than U.S. dollars. There are some bonds whose principal and interest payments are not in the same currency. These bonds are called *dual currency bonds*. A few bond issues even give the bondholder the choice between receiving interest and principal in U.S. dollars or some other currency.

Term to Maturity

If a firm borrows by issuing a bond, it must repay the debt obligation at some specified point in time, referred to as the *maturity date*—the date the bond “matures.” The number of years until a bond matures is called the *term to maturity* or simply the *term* or the *maturity* of the bond. There is no limit to the maturity. Bonds and notes are often classified in terms of their maturity, though this is a very loose classification. Obligations with original maturities less than 10 years are usually called *notes*. *Bonds* are generally considered to be obligations with original maturities of 10 years and beyond. Corporate bonds usually have maturities ranging from 15 to 30 years, though issuers can design bonds with any maturity. In the mid-1990s, several major U.S. companies issued bonds with nontraditional maturities of 50 years (e.g., Boeing and Ford Motor Company) and 100 years (e.g., Disney, Bell-South Corporation, and News Corporation).

Interest

In the United States, interest to bondholders is typically paid twice a year at six-month intervals. Bonds issued in many other countries pay interest annually. A bond can be designed to pay interest quarterly, monthly, or even daily, any way the corporation desires. The objective is to design the interest payments to be attractive to the investors, but at the same time minimize the costs of administering the bonds—writing and mailing interest payments.

Interest is also referred to as a *coupon*. Interest is generally stated as a percentage of the par value of the bond and the rate or interest is referred to as the interest rate or the *coupon rate*. The coupon rate can be either a fixed coupon rate (fixed rate) or a floating coupon rate (floating rate). Most bonds have a fixed coupon rate and such issues are said to have a *straight coupon*.

There have been many innovations in the types of debt interest payments, so there is no longer any typical bond. We'll review one type: zero-coupon bonds. As the name suggests, the bonds do not have a coupon. Since there are no coupons, the only return an investor gets by holding the bond until it matures is the difference between what was paid for the bond and its maturity value. Effectively, the investor in a zero-coupon bond earns interest, but the investor does not receive it until the maturity date—the interest is part of the maturity value. Consider The Walt Disney Co. Zero-coupon Subordinated Notes that matured in June 2005. These notes were issued in June 1990 at 41.199 (41.199% of their maturity value). An investor buying a \$1,000 maturity value note in June 1990 would pay \$411.99. If that investor held onto the bond until the maturity date, she would not receive interest during the life of the bond, but she would receive \$1,000 in June 2005.

As with interest paid on any kind of debt, the issuer may deduct the implicit interest to determine taxable income. Investors are taxed on the bond's interest income—the implicit interest—even though they receive no cash. Consider the Disney notes. An investor who purchased a note for \$411.99 in June 1990 and held it until maturity on June 2005 earned an annual return of 6.09%.³ Implied interest for the first year is 6.09% multiplied by \$411.99, or \$25.09. Implied interest for the second year is 6.09% multiplied by \$411.99 + \$25.09 = \$437.08, or \$26.62. As time passes, the value of the note increases and the implicit interest on the note in any period is the 6.09% multiplied by the increased value. Implicit interest on the Disney note over its life is shown for each year in Table 3.3.

Somewhere between a zero-coupon bond and a straight coupon bond lies a *deferred interest bond*—a bond whose interest payments do not start until some time after it is issued. Most deferred interest bonds have no interest for the first three to seven years. Deferred interest debt is usually used where cash flow problems are anticipated. For example, if a firm borrows heavily to restructure its operations, deferred interest debt offers time to turn its operations around.

Security

A bond may be unsecured or secured with the pledge of specific property called *collateral*. A debt that is not secured by specific property is referred to as a *debenture*. If the obligations of the loan are not satisfied, the creditor has the right to recoup the amount of principal, any accrued interest, and

³ This is found as follows. We know the (1) present value of the investment = \$411.99; (2) future value of the investment = \$1,000.00; and, (3) number of periods = 15. Then

$$\text{Return} = (\$1,000.00/\$411.99)^{1/15} - 1 = 6.09\%$$

TABLE 3.3 Implied Interest on Disney Zero-Coupon Subordinated Notes, Due 2005, That Were Issued June 1990 at 41.199 or \$411.99 per Bond

| For the year ended June ... | Beginning of the Year Value | Implied Interest = Yield × Beginning Value | End of Year Value = Beginning Value + Implied Interest |
|-----------------------------|-----------------------------|--|--|
| 1991 | \$411.99 | \$25.09 | \$437.08 |
| 1992 | 437.08 | 26.62 | 463.70 |
| 1993 | 463.70 | 28.24 | 491.94 |
| 1994 | 491.94 | 29.96 | 521.90 |
| 1995 | 521.90 | 31.78 | 553.68 |
| 1996 | 553.68 | 33.72 | 587.40 |
| 1997 | 587.40 | 35.77 | 623.17 |
| 1998 | 623.17 | 37.95 | 661.12 |
| 1999 | 661.12 | 40.26 | 701.38 |
| 2000 | 701.38 | 42.71 | 744.10 |
| 2001 | 744.10 | 45.32 | 789.41 |
| 2002 | 789.41 | 48.07 | 837.49 |
| 2003 | 837.49 | 51.00 | 888.49 |
| 2004 | 888.49 | 54.11 | 942.60 |
| 2005 | 942.60 | 57.40 | 1,000.00 |
| Total implied interest | | | \$588.01 |

Note:

Yield calculation:

$$\text{Yield} = \sqrt[T]{\frac{\text{Future value}}{\text{Present value}}} - 1 = \sqrt[15]{\frac{\$1,000.00}{\$411.99}} - 1 = 6.0899\%$$

Check on the calculations:

$$\begin{array}{rclcl} \text{Total implied interest} & + & \text{price when issued} & = & \text{Face value} \\ \$588.01 & + & \$411.99 & = & \$1,000.00 \end{array}$$

penalties from the proceeds from the sale of the pledged property in the case of secured debt. Unsecured bonds, as well as secured bonds, are backed by the general credit of the firm—the ability of the firm to generate cash flows that are sufficient to meet its obligations.

There are different types of secured bonds, classified by the type of property pledged. If the pledged property is real property—such as land or buildings—the debt is referred to as a *mortgage*. If the pledged property is

any type of financial asset, such as stocks or bonds of other corporations, the bond is referred to as *collateral trust bond*, since the stocks and bonds are held in a trust account until the bond is satisfied. If the pledged property is equipment, the secured debt is referred to as an *equipment obligation* or *equipment trust debt*. Equipment trust debt, also referred to as equipment trust certificates, are often used by railroads to purchase rolling stock and airlines to finance the purchase of aircraft.

Seniority

A firm can issue different kinds of bonds. But not all bonds are created equal. There is a pecking order of sorts with respect to each bondholder's claim on the firm's assets and income. This pecking order is referred to as *seniority*. One bond issue is *senior* to another if it has a prior claim on assets and income; one bond issue is *junior* to another if the other bond has a prior claim on assets and income. A *subordinated bond* is a bond that is junior to another.

Debt Retirement

By the maturity date of the bond, the issuer must pay off the entire outstanding balance of the bond. The issuer can do so in one of following four ways:

1. Repay the entire amount in one payment at maturity. This is the typical mechanism for bonds issued by corporations.
2. Repay the par value based on an amortization schedule. This mechanism is the same as for the repayment of the amount borrowed for the term loans described earlier. That is, each periodic payment made by the firm to bondholders includes interest and scheduled principal repayment.
3. Retire a specified amount of the par value of the issue periodically. This provision is called a *sinking fund provision*.
4. Pay off the entire amount of the par value prior to the maturity date by one of two mechanisms: "calling" the issue if permitted or "defeasing" the issue.

The first two mechanisms are straightforward. We describe the sinking fund, call, and defeasing mechanisms next, beginning with the call mechanism. In addition to the above mechanisms, a bond issue may give the bondholder the right to force the issuer to retire a bond issue prior to the maturity date. This right granted is referred to as a *put provision*.

An important question in setting the terms of a new bond issue is whether the issuer shall have the right to redeem the entire amount of bonds outstanding on one or more dates before the maturity date. Issuers generally want this right because they recognize that at some time in the future the general level of interest rates may fall sufficiently below the issue's coupon rate so that redeeming the issue and replacing it with another issue with a lower coupon rate would be attractive. This right is a disadvantage to the bondholder because it forces the bondholder to reinvest the proceeds received at a lower interest rate.

The right of the issuer to retire an issue prior to the maturity date is referred to as the right to *call the issue*. Effectively, it is the right of the issuer to take away the bonds from the bondholder at a specified price at specified times. Consequently, this right that the issuer has is referred to as a call option and since it is part of a bond issue is referred to as an *embedded option*. As we discuss other features of a bond we will see other types of embedded options.

Retiring an outstanding bond issue with proceeds from the sale of another bond issue is referred to as *refunding a bond issue*. The usual practice is a provision that denies the issuer the right to refund a bond issue during the first 5 to 10 years following the date of issue with proceeds received from issuing lower-cost debt obligations ranking equal to or superior to the bond issue to be retired. For example, if a bond issue has a coupon rate of 8% and the issuer could issue a new bond issue with a coupon rate of 6%, then if there is a prohibition on refunding a bond issue, the issuer could not retire the 8% coupon issue with funds received from the sale of a 6% issue. While most long-term issues have these refunding restrictions, they may be immediately callable, in whole or in part, if the source of funds comes from other than lower interest cost money. Cash flow from operations, proceeds from a common stock sale, or funds from the sale of property are examples of such sources of proceeds that a firm can use to refund a bond issue.

Sometimes there is confusion between refunding protection and call protection. Call protection is much more absolute in that bonds cannot be redeemed for any reason. Refunding restrictions provide protection only against the one type of redemption mentioned above.

Typically, corporate bonds are callable at a premium above par. Generally, the amount of the premium declines as the bond approaches maturity and often reaches par after a number of years have passed since issuance.

There are economic models that can be used by a CFO to provide guidance in the decision as to whether it will benefit the corporation to refund a bond issue.

Bond indentures may require the issuer to retire a specified portion of an issue each year. This is referred to as a *sinking fund requirement*. This

kind of provision for repayment of a bond issue may be designed to pay off all of a bond issue by the maturity date, or it may be arranged to pay only a part of the total by the maturity date.

Generally, the issuer may satisfy the sinking-fund requirement by either (1) making a cash payment of the par amount of the bonds scheduled to be retired to the trustee, who then calls the bonds for redemption using a lottery, or (2) delivering to the trustee bonds with a total par value equal to the amount that must be retired from bonds the issuer purchased in the open market. Usually, the sinking-fund call price is the par value of the bonds.

Many corporate bond indentures include a provision that grants the issuer the right (i.e., option) to retire more than the required sinking fund payment. For example, suppose that the amount of the sinking fund requirement is \$10 million for some year up to a specified amount. The issuer would have the right to retire more than \$10 million. For some issues, the issuer may be permitted to retire a multiple of the amount required. This is another embedded option granted to the issuer, called the *acceleration option*, because the issuer can take advantage of this provision if interest rates decline below the coupon rate. There is another advantage. When bonds are purchased to satisfy the sinking fund requirement, they are called at par value. In contrast, when they are called, if the issuer has the right to call an issue, for other than to satisfy the sinking fund requirement, the call price is typically above the par value.

Another way of effectively retiring a bond issue is to *defease* it by creating a trust to pay off the payments that must be made to the bondholders. To do this, the firm establishes an irrevocable trust (where the firm cannot get back any funds it puts in it), and deposits risk-free securities into the trust (such as U.S. government bonds) such that the cash flows from these bonds (interest and principal) are sufficient to pay the obligations of the debt. The interest and principal of the defeased debt is then paid by this trust. An issuer would employ the defeasance mechanism for several reasons: (1) if the bonds cannot be bought back from the bondholders (the issue cannot be called or refunded), (2) it provides a way of retiring bonds, (3) if interest rates on the securities in the trust are high relative to the interest rate on the defeased bond, this difference ends up increasing the firm's reported earnings, and (4) if certain requirements are met, as set forth in the Financial Accounting Standards Board's Statement of Financial Accounting Standards No. 76, the debt obligation is removed from the borrower's financial statements, which should lead to an improved credit evaluation.

A *put provision* grants the bondholder the right to sell the issue back to the issuer on designated dates. Bonds with such a provision are referred to as *puttable bonds*. The advantage to the bondholder is that if interest rates rise after the bonds are issued, thereby reducing the value of the bond, the bondholder can put the bond to the issuer for par value. The put provision,

just like the call provision, is an embedded option. Consequently, the put provision is referred to as a put option. Unlike a call option, which is an option granted to the issuer to retire the bond issue prior to the maturity date, a put option grants the bondholder the right to have the bond issue retired prior to the maturity date.

Put provisions have been used for reasons other than to protect the bondholder against a rise in interest rates after the bond is issued. The right to sell the debt back is permitted under special circumstances. In the late 1980s, many firms took on a great deal of debt, increasing the risk of default on all their debt obligations. Many debtholders found themselves with debt whose default risk increased dramatically. Put provisions were included in bond indentures as a way of protecting bondholders. If an event affecting the bond issue took place, such as a leveraged buyout or a downgrade in the credit rating of the issuer, bondholders have the right to sell the bonds back to the issuer.⁴

Hybrid Securities

A *hybrid security* is a security that has both debt- and equity-like features. One type of hybrid is a convertible security, such as a convertible bond. A convertible security is a security that is a debt obligation that can be converted into equity at the debt owner's option. Another type of hybrid is the trust-preferred security.

The fact that these securities have both debt and equity features makes their classification difficult for bond raters, analysts, and regulators. In 1999, Moody's issued its *debt-equity continuum*, which is a classification of hybrids as both debt and equity, depending on the features of the security. Moody's refined this continuum criteria in 2003 to accommodate the growth and innovations in hybrids, introducing a five-part classification system referred to as "baskets":⁵

⁴ In the late 1980s, some firms issued puts designed specifically to make takeovers more expensive. Called "poison puts," they take effect only under some specified change in control of the firm, such as if someone acquires more than 20% of the common stock. By designing puttable bonds with this feature, the management is able to make any takeover more expensive. Bondholders will want to sell the bonds back to the firm for more than their par value, draining the company of cash. A "change in control" put provision may state: "In the event of a change-in-control of Co., each holder will have the one-time optional right to require Co. to repurchase such holder's debentures at the principal amount thereof, plus accrued interest." If there is a change in control, as defined in more detail in the indenture, the bondholder can "put" the bond back to the issuer at par value.

⁵ "Hybrid Securities Analysis: New Criteria for Adjustment of Financial Ratios to Reflect the Issuance of Hybrid Securities Product of the New Instruments Committee," Moody's Investor Service, November 2003.

| | |
|----------|-------------------------|
| Basket A | 100% debt |
| Basket B | 75% debt and 25% equity |
| Basket C | 50% debt and 50% equity |
| Basket D | 25% debt and 75% equity |
| Basket E | 100% equity |

A hybrid security is assigned to a basket for purposes of assigning some or all of the hybrid to debt for purposes of financial analysis of the issuer.

In 2005, the Federal Reserve Board decided to allow banks to hold up to 15% of their Tier 1 capital—which is, essentially, its financial capital—in the form of trust-preferred securities.⁶ This action further encouraged bond-rating agencies to view hybrid securities as part debt and part equity.⁷

However, the accounting treatment of hybrids is still evolving. The International Accounting Standards Board (IASB) permits classifying convertible debt, for example, as part debt and part equity. U.S. standards, on the other hand, are currently being reviewed.⁸

Convertible Securities

A conversion feature gives the investor the right to exchange the bond issue for some other security of the issuer, typically shares of common stock, at a predetermined rate of exchange. A bond issue that has such a feature is called a *convertible bond*. Almost all convertible issues are callable by the issuer. This is a valuable feature for issuers who deem the current market price of their stock undervalued enough so that selling stock directly would dilute the equity of current stockholders. The firm would prefer to raise common stock over incurring debt, so it issues a convertible, setting the price at which conversion can be exercised on the basis of a stock price it regards as acceptable. Once the market price reaches the conversion point, the firm will want to see the conversion happen in view of the risk that the stock price may drop in the future. This gives the firm a motive to force conversion, even though this is not in the interest of the owners of the bond, whose price is likely to be adversely affected by the call.

⁶ Federal Reserve System 12 CFR Parts 208 and 225, “Risk-Based Capital Standards: Trust Preferred Securities and the Definition of Capital,” Board of Governors of the Federal Reserve System, Final Rule, March 4, 2005.

⁷ Ronald Fink, “Two-Way Tools,” *CFO Magazine*, June 1, 2006.

⁸ For example, Statement of Financial Accounting Standards, No. 150, “Accounting for Certain Financial Instruments with Characteristics of Both Liabilities and Equity,” issued May 2003, specifically did not consider instruments such as convertible debt. The issues of reporting of financial instruments that have both debt and equity components are being addressed in a joint FASB/IASB project entitled “Financial Instruments: Liabilities and Equity.”

Why does a firm needing funds issue a convertible bond? Conversion is attractive to investors because they can switch their convertible bond to common stock if the shares do well. So, investors are willing to accept a lower yield on convertible bond. This means a lower cost of financing for the issuer. Another reason a firm may issue a convertible bond is weak demand for its common stock. But by issuing a convertible bond, the firm is, in effect, issuing a stock at a later time if the stock price increases.

Trust-Preferred Securities

A *trust-preferred security* is a preferred stock issued by a trust subsidiary of a company, typically a bank holding company or a regulated utility. The trust uses the proceeds of the issuance of the trust-preferred securities to buy subordinated debt of the parent company. The parent company therefore has the benefit of deducting the interest paid on the subordinated debt, but also has a minority interest in the trust.⁹ If the parent company is a bank holding company, it can use this as a portion of its Tier 1 capital, which helps the company satisfy tests of capital adequacy. However, trust-preferred securities are treated as debt for financial accounting purposes and may be treated as such for purposes of bond covenants.

Designing a Bond Issue

A CFO seeking to raise funds via a bond offering wants to issue a security with the lowest cost and the flexibility to retire the debt if interest rates fall. An investor wants a bond issue that provides the highest yield, lowest risk, and the flexibility to sell it if other, more profitable investment opportunities arise. The best package of debt features will provide what investors are looking for (in terms of risk and return) and simultaneously what the firm is willing to offer (in terms of risk and cost).

There is a wide range of features available with respect to denomination, type of coupon rate, security/collateral, call features for retiring a bond issue prior to the maturity date, and conversion options that make it possible to design a bond issue to meet both the needs of the issuer and investors. Features that make an issue more attractive to investors decrease the yield investors want. As a result, the issuer's borrowing cost is reduced. For example, the inclusion of embedded options such as a conversion feature and a put option make the issue more attractive to investors, so an issuer

⁹ One of the unresolved issues is how these securities are treated for U.S. tax purposes. It is possible for the Internal Revenue Service to interpret a particular security as equity—for example, if the security is perpetual—in which case the interest on the subordinated debt is not tax-deductible.

would expect that the inclusion of such features would reduce the yield at which it would have to offer a bond. In contrast, features included in a bond issue that are an advantage to the issuer increase the yield investors want and therefore increase the cost of the bond issue. For example, the inclusion of covenants that favor the issuer or the inclusion of embedded options such as the call option and the acceleration option, add to the cost of a bond issue.

In an efficient market, investors fairly price the value of the favorable and unfavorable features into the offering price. Opportunities for an issuer to obtain a higher offer price for a bond issue (i.e., a lower cost) arise only if for some reason the market is not pricing these features properly. For example, suppose that investors buy a particular bond issue at issuance that is callable and is undervaluing the call option. This means that the issuer is buying a cheap call option and therefore the issuer's cost for the bond issue is lower than if the call option is priced fairly. However, suppose that the same issuer did not want a call option. The issuer can take advantage of effectively buying a cheap call by issuing the callable bond and simultaneously entering into a transaction to sell a call option in the over-the-counter market. Basically, the issuer effectively bought a call option by issuing the callable bond and sold a call option with the same terms as the embedded call option at a higher price. The net effect is that the proceeds realized from the sale of the call option in the market reduce the issuer's cost for the bond issue relative to issuing a noncallable bond.

In an efficient market, there are opportunities to reduce the cost of a bond issue if a new, innovative bond structure can be designed that is not currently available in the marketplace. What type of innovation must that be? The innovation must be such that it either enables investors to reduce a risk that previously could not have been reduced efficiently through currently available financial instruments, or takes advantage of tax or financial accounting loopholes that benefit the issuer and/or investors. The first type of innovation, risk-reducing features, eventually are introduced by other issuers so that only those issuers who are first to introduce those features will benefit. Investment bankers who see a new innovation introduced by a competitor firm promptly notify their clients about the opportunity to issue bonds with this feature. As a result, the uniqueness of the feature wanes and there is no advantage to issuing a bond with this feature—that is, the issuer gets a fair market value for the feature. For innovations that result from tax or financial accounting loopholes, those advantages disappear once the Internal Revenue Service changes tax rules or the Financial Accounting Standards Board changes the financial accounting rules that created the loophole.

Fixed-Rate versus Floating-Rate

One of the first questions a CFO seeking to borrow via a bond offering must address is whether to issue a floating-rate or fixed-rate bond. Issuers of floating-rate bonds fall into one of two categories. The first are financial entities whose assets that they invest in pay a floating interest rate. For example, suppose that a finance company makes loans where the interest payment it receives is 3-month LIBOR plus 300 basis points. If the finance company issues fixed-rate bonds, the risk that the CFO would be accepting is that 3-month LIBOR may increase to a level where the interest payment it receives from the loans may be less than the fixed rate it pays to borrow funds. A properly designed floating-rate bond eliminates that problem. If the finance company can borrow funds on a floating-rate basis where it pays, for example, 3-month LIBOR plus 30 basis points, then the finance company is earning a spread of 270 basis points—the difference between 3-month LIBOR plus 300 basis points it receives from the loans and 3-month LIBOR plus 30 basis points it pays to bondholders. If 3-month LIBOR increases or decreases, the CFO has locked in a spread for the finance company.

The second type of issuer of floating-rate bonds is a corporation that does want to lock in a fixed-rate bond but issues a floating-rate bond. Why does a corporation take on the risk that market interest rates will rise in the future and therefore it will have to pay a higher interest rate? One possibility is that the corporation will benefit if interest rates go down and that is the expectation of the CFO. Typically, that is not the reason. The reason is in fact that the corporation ultimately does not take on the risk that interest rates will rise. This is done by combining the issuance of a floating-rate bond with the use of an interest rate swap. We will introduce the basic elements of an interest rate swap in Chapter 8. An interest rate swap allows an issuer to change floating-rate payments into fixed-rate payments. By doing so, the issuer of a floating-rate bond who simultaneously enters into an interest rate swap in which it receives a floating rate and pays a fixed rate has *synthetically* created a fixed-rate bond. This is because the floating rate that the issuer receives pays the bondholders of the floating-rate bonds that it issued. We will illustrate how this is done in Chapter 8, when we discuss how swaps are used in conjunction with designing a bond offering.

Economic theory tells us that if markets are efficient, then whether a corporation synthetically creates a fixed-rate bond by issuing a floating-rate bond and using a swap or by just issuing a fixed-rate bond, the cost of funds will be the same to the issuer after transaction costs. Therefore, why shouldn't a CFO just issue a fixed-rate bond? The answer lies in an understanding of how markets operate.

Institutional bond buyers impose constraints on the amount that they will invest in a particular issuer, or in fact, issuers in a particular sector of the bond market. Suppose a corporation has historically issued only fixed-rate bonds. When this corporation is contemplating a new bond offering, the CFO will approach its investment banker about how much it will cost to raise the target amount of funds. The sales force of the investment banking firm will canvass its bond customers to assess what it will cost the issuer to issue a fixed-rate bond. Suppose that the banker's sales force indicates that most fixed-rate bond buyers are not willing to purchase any additional fixed-rate bonds issued by this corporation because it has realized its maximum exposure. This may mean a higher cost for issuing the bond. The sales force, however, may indicate that institutional buyers of floating-rate bonds will be more receptive to the corporation since they do not have any credit risk exposure to the corporation. The investment banker would then determine what the cost of a synthetically created fixed-rate bond issue will be if the corporation issued a floating-rate bond and used an interest rate swap. If the cost is lower, the corporation may issue the floating-rate bond. Even if the cost is close to the same, the CFO may decide to synthetically create a fixed-rate bond just to increase its presence in the floating-rate market.

It is for the same reason that corporations needing to issue bonds with a floating rate will issue a fixed-rate bond and enter into an interest rate. In this case, the corporation will agree to pay a floating rate and receive a fixed rate, thereby synthetically creating a floating-rate bond.

Medium-Term Note

A *medium-term note (MTN)* is a debt instrument, with the unique characteristic that the securities are offered continuously to investors by an agent of the issuer. Investors can select from several maturity ranges: 9 months to 1 year, more than 1 year to 18 months, more than 18 months to 2 years, and so on up to 30 years. MTNs are registered with the SEC under Rule 415 (the shelf registration rule), which gives a corporation the maximum flexibility for issuing securities on a continuous basis.

The term "medium-term note" to describe this debt instrument is confusing. It has nothing to do with the maturity of the debt instrument. Traditionally, the term *note* or *medium term* has been used in referring to debt obligations with a maturity exceeding 1 year but less than 15 years. This is not a characteristic of MTNs, since they have been sold with maturities from 9 months to 30 years, and even longer. The MTNs issued by Walt Disney Corporation in July 1993 is an example. This MTN has a 100-year maturity. Historically, the original purpose of the MTN was to fill the fund-

ing gap between commercial paper and long-term bonds and it is for this reason that they are referred to as “medium term.”

The way that MTNs differ from corporate bonds is in the manner in which they are distributed to investors when they are initially sold. Although some investment-grade corporate bond issues are sold on a best-efforts basis, typically they are underwritten by investment bankers. Traditionally, MTNs have been distributed on a best-efforts basis by either an investment banking firm or other broker-dealers acting as agents. Another difference between corporate bonds and MTNs when they are offered is that MTNs are usually sold in relatively small amounts on a continuous or an intermittent basis. In contrast, corporate bonds are sold in large, discrete offerings.

If a CFO wants an MTN program, a shelf registration must be filed with the SEC for the offering of securities. The CFO then posts rates over a range of maturities: for example, 9 months to 1 year, 1 year to 18 months, 18 months to 2 years, and annually thereafter. Usually, the CFO will post rates as a spread over a Treasury security of comparable maturity. Agents for the MTN program will then make the offering rate schedule available to their interested investor base. An investor who is interested in the offering will contact the agent. In turn, the agent contacts the issuer to confirm the terms of the transaction. Since the maturity range in the offering rate schedule does not specify a maturity date, the investor can choose the final maturity subject to approval by the issuer.

A special type of MTN is one in which the issuer couples its MTN offering with transactions in the derivative markets (options, futures/forwards, swaps, caps, and floors) so as to create debt obligations with more interesting risk/return features than are available in the corporate bond market. MTNs with this feature are called *structured notes* and these will be described in the next chapter.

SHORT-TERM FINANCING

Now we turn to short-term financing. In general, these forms of financing are classified as unsecured and secured. The cost of short-term financing is a function of many factors, including (1) the prevailing interest rates, (2) creditworthiness of borrower (credit rating), (3) length of maturity of borrowing, (4) level of seniority, (5) collateral, and (6) backup line of credit. In comparing the cost of alternative short-term financing arrangements, the CFO must put the cost on an effective annual basis in order to facilitate this comparison. To do so, the CFO must consider any discount interest, compensating balance requirements (explained below), and fees.

Unsecured Financing

In some types of financing, the creditor is counting on being paid the promised interest and principal, relying on the general creditworthiness of the borrower. But other creditors want more assurance of being paid back. This assurance is provided in the form of the borrower's property specified to be transferred to the lender if the borrower fails to pay as promised.

A loan that is "backed" by specific property is a *secured loan*. A loan that is backed only by the general credit of the borrower is an *unsecured loan*. There are several different types of unsecured loans. We take a look at the more widely used types of unsecured credit: trade credit, bank loans, commercial paper, and bankers' acceptances.

Trade Credit

Trade credit is granted by a supplier to a customer purchasing goods or services. Trade credit arises spontaneously as the customer acquires goods or services and promises to pay some time in the future. From the seller's point of view, trade credit is a way of making more sales. From the customer's point of view, trade credit is an easy way to finance the purchase of goods. Once a satisfactory relationship is established between the seller and the customer, trade credit is granted automatically. For the seller, trade credit creates accounts receivable; for the customer, trade credit creates accounts payable.

Bank Financing

Banks lend money to firms under different financing arrangements. The financing arrangement may be straightforward, such as a single payment loan. Or a firm may obtain from a bank its promise to lend, such as a line of credit or revolving credit.

A *single payment loan* is the simplest short-term financing arrangement. In a single payment loan, the borrower negotiates a loan of a specific sum from the lender, usually a bank, and agrees to repay the loaned amount at the end of a specified period.

Short-term bank loans are generally self-liquidating. That is, they are used to acquire assets and the cash flows from these assets are sufficient to pay off the loan. Bank loans are represented in the form of a promissory note, which specifies the amount of the loan, the maturity date, and any interest. With single payment interest, the borrower receives the amount of the loan, paying back the full amount of the loan plus interest at maturity. The interest rate in a single payment loan may be either fixed or floating.

Rates are often quoted relative to LIBOR or the *prime rate*. The prime rate is the rate banks charge their most creditworthy customers.

A *line of credit* is an agreement wherein a bank will make available to a firm a loan up to a specific limit—the “line”—if the firm requests these funds. The bank extends this line of credit for a specified period, typically one year.

A line of credit is a flexible source of credit. When a firm borrows under a line of credit, it takes out notes payable to the bank, which range in maturity from one to 90 days. A bank may require that the borrower “clean-up” the line—pay off the borrowings completely—for a specified period of time.

A line of credit may be uncommitted or committed. In an uncommitted line of credit, the bank makes a verbal agreement to lend funds up to the line within the specified period, but is not legally bound to do so. In a committed line of credit, the bank makes a written agreement to lend funds and is legally bound to do so under the terms of the line of credit. The cost of the line of credit comprises two costs. First, the borrower pays interest at a specified rate only on the funds borrowed and for the time borrowed. Second, if the agreement is a committed line of credit, the borrower pays either a commitment fee—from 1/4% to 1/2% of the unused portion of the line of credit—or must maintain a specified compensating balance for the period of the line of credit. A compensating balance is a cash balance in a non-interest-bearing or low-interest-bearing account required by banks in exchange for banking services such as a bank loan. By keeping a balance in an account that is non-interest bearing or low-interest bearing, the borrower is effectively compensating the bank for the loan. In the case of the line of credit, the firm incurs some cost, though likely quite small, even if it does not borrow anything against the line.

In addition to the fee or compensating balance, there may be some covenants that limit the actions of the borrower. Covenants may require that the borrower provide financial statements periodically or that the certain financial ratios, such as a minimum interest coverage or current ratio, be satisfied. These covenants do not usually restrict the decision making of the borrower, but serve to protect the lender in extreme cases.

A *revolving credit agreement* is similar to a line of credit agreement, but is usually for a longer period—two to three years. The borrower can borrow and repay the credit many times within this period in a series of short-term notes. The cost of the revolving credit comprises two parts: (1) the commitment fee or compensating balance, and (2) the interest on any borrowings under the agreement. Unlike the line of credit, revolving credit agreements usually specify a floating rate. Typically, the borrower and lender renegotiate the revolving line of credit prior to maturity, insuring a continuous source of funds for the borrower.

Commercial Paper

Commercial paper is an unsecured promissory note with a fixed maturity issued by the borrower. Almost all commercial paper is backed up by a line of credit from a bank. If commercial paper is backed and the borrower is unable to pay the lender at maturity, the bank stands ready (for a fee) to lend the borrower funds to pay off the maturing paper.

Most commercial paper notes issued in the United States have maturities from 3 to 270 days, but average 30 days. This is because if a security has a maturity of more than 270 days, the issuer must register the security with the SEC. Doing so would delay the issuance and increase the cost of issuing the paper. Though these maturities are relatively short, some firms tend to use commercial paper for financing over longer periods of time. They do this by rolling over the paper—as the paper matures, they issue new commercial paper to pay off the maturing commercial paper.

Finance companies and nonfinancial companies issue commercial paper. Finance companies, such as General Motors Acceptance Corporation (GMAC) and C.I.T. Financial Corporation, are in the business of lending funds to consumers, usually for consumer durables such as automobiles. Finance companies tend to continually roll over their commercial paper since it is the major source of funds to use for their lending business. Non-financial companies tend to issue commercial paper to meet their seasonal financing needs.

Commercial paper is classified as either direct paper or dealer paper. Direct paper is sold by the issuing firm directly to investors without using a securities dealer as an intermediary. The vast majority of the issuers of direct paper are financial firms. Because financial firms require a continuous source of funds in order to provide loans to customers, they find it cost effective to establish a sales force to sell their commercial paper directly to investors. Direct issuers post rates at which they are willing to sell commercial paper with financial information vendors such as Bloomberg, Reuters, and Telerate. In the case of dealer-placed commercial paper, the issuer uses the services of a securities firm to sell its paper.

Although commercial paper is a short-term security, it is issued within a longer term program: U.S. commercial paper programs are often open-ended. For example, the CFO might establish a five-year commercial paper program with a limit of \$300 million. Once the program is established, the company can issue commercial paper up to this amount. The program is continuous and new commercial paper can be issued at any time, daily if required.

Bankers' Acceptances

A *bankers' acceptance* is a bank's commitment to pay someone else's promise to pay a specified amount at a specified date as represented by a time draft. With a bankers' acceptance, the bank is committing itself to making the specified payment at the maturity of the draft if the issuer of the draft does not pay. Bankers' acceptances are typically used in international trade, though they may be used domestically as well. They generally have maturities of less than 270 days. Although there are a variety of ways a bankers' acceptance can be arranged, the basic idea behind all of them is that a letter of credit is transformed into a financial instrument that can be bought and sold in the open market. The cost of a bankers' acceptance includes a commitment fee or commission for the commitment, and the interest rate on the loan if the bank makes the payment on behalf of the issuer.

A bankers' acceptance is similar to commercial paper. They both can be traded among investors, both have maturities of less than 270 days, and both generally have discount interest. But they differ in two ways. The first is the way in which they are created. The second is their risk. Commercial paper is backed by the issuer, which may have a backup line of credit; bankers' acceptance is backed by the issuer, yet the bank stands ready to pay the face value. The lower risk on the bankers' acceptances results in slightly lower cost than the costs of commercial paper.

Secured Financing

Secured financing is “backed” by collateral of some specific asset or assets of the borrower. The collateral acts as a backup source of funds for the lender if the borrower fails to abide by the terms of the loan. The collateral for short-term financing arrangements is usually current assets—marketable securities, accounts receivable, or inventory. Below we will describe two types of secured financing arrangements: accounts receivable financing and inventory financing.¹⁰

Accounts Receivable

Accounts receivable can be used as collateral for a secured loan. There are three types of financing arrangements that use accounts receivable as security: assignment, factoring, and securitizing. Securitizing assets, also referred to as *asset securitization*, is an important financing arrangement for raising

¹⁰ Another form of financing uses securities as collateral and is called a *repurchase agreement*. This form of financing is predominately used by financial institutions and will not be discussed here.

short- to intermediate-term funds. In the next chapter we discuss the process of asset securitization.

The simplest form of accounts receivable financing is the assignment of receivables. In an *assignment of receivables*, the lender makes a loan accepting the borrower's accounts receivable as the collateral. The borrower receives immediate cash in exchange for a promissory note to the lender. This type of financing may be either a non-notification or a notification plan. In the case of a non-notification plan, customers pay the company and the company in turn pays the bank. In the case of a notification plan, the borrower's customers are generally instructed to send their payments to the lender, who uses these payments to reduce the amount of the loan. This type of financing is flexible since the lender increases the loan as more receivables are generated (as acceptable collateral by the borrower) and reduces the loan as these receivables are paid off. Therefore the borrowed amount fluctuates with the needs of the borrower.

A borrower can go a step further in financing with accounts receivable. Instead of simply using accounts receivable as collateral, the borrower can sell them outright to another party—called a *factor*—typically a bank or a commercial finance company. Selling the receivables—called *factoring*—may be done with or without recourse. In a factoring arrangement *without recourse*, the factor performs all the accounts receivable functions: evaluating customers' credit, approving credit, and collecting on accounts receivable. If any of the accounts turn out to be uncollectible, the factor bears the bad debt. If a borrower has an arrangement with a factor *with recourse* and the borrower grants credit without permission from the factor, the borrower assumes responsibilities for collection of the account.

There are basically two types of factoring, maturity factoring and conventional factoring. They differ with respect to when cash is received for the receivables. In *maturity factoring*, the customer sends cash to the factor, who then sends the cash (less a commission) to the seller. In *conventional factoring*, the factor advances cash to the seller when the accounts are factored, and then keeps the customers' payments as they come in. Because factoring is a substitute for having accounts receivable personnel, whether a CFO should use factoring requires comparing what it costs to operate the receivables function with the factor's commission.

Inventory

Inventory can also be used as collateral for financing since it is a fairly liquid asset. Not all inventory is of equal importance as collateral: The amount of funds loaned depends on how easy it is for the lender to turn the inventory into cash. In general, (1) standardized inventory is much better than

specialized inventory, (2) nonperishable inventory is better than perishable inventory, and (3) raw materials and finished goods are better than work-in-process.

There are several different types of loan arrangements that involve inventory as collateral. These arrangements differ in terms of the control that the lender has over the location and disposition of the inventory. A *floating lien* is the most flexible type of inventory loan. A floating lien gives the lender a lien on all inventory of the borrower—that is, all inventory is collateral for the loan. Therefore the collateral for the loan changes as the borrower buys and sells inventory.

A *chattel mortgage* is a loan secured by specified inventory. In other words, inventory items are uniquely identified, such as by serial number, as collateral for the loan. The borrower retains title of the inventory. And although the borrowing firm still owns the inventory, it cannot sell the inventory unless the lender gives permission. This type of loan is best suited for inventory that consists of large, slow-moving items.

In a *trust receipts loan*, the borrower holds the inventory in trust for the lender. As the inventory is sold, the borrower keeps the proceeds in trust for the lender. This type of arrangement is also referred to as *floor planning* and is used often with auto dealerships and other types of inventory in which the merchandise is serial numbered. First, the borrower arranges a loan with the finance company. The borrower then orders and receives the inventory, with the finance company paying the supplier. As the borrower sells the inventory items, the borrower remits the payments to the finance company, reducing the amount of the loan. Because the finance company is counting on the borrower to maintain the inventory (keep it in good condition) and send the payments when sales are made, the lender must devise a way to monitor the borrower.

In a *field warehouse loan*, the lender has tighter control over the inventory. The collateral (the inventory) is kept in a separate, secured area within the borrower's premises and is monitored by a field warehouse agent. This agent keeps control over the inventory in this area and issues receipts to the lender, indicating the existence of the inventory. As the lending entity receives these receipts, it makes a loan based on the collateral value of the inventory. This arrangement is more expensive than the floating lien, chattel mortgage, and trust receipts arrangements because a third party—the field warehouse—must be compensated for the services provided. This arrangement offers the lender more peace of mind over the inventory.

Even tighter control over collateral inventory is maintained in a public warehouse loan arrangement. In a *public warehouse loan*, collateral inventory is kept in a secured area away from the borrower's premises, such as in a public warehouse, and is only released to the borrower if the lender gives

permission. The warehouse issues to the lender receipts (similar to the field warehouse arrangement) from which the lender acknowledges in the form of money loaned to the borrower. In this arrangement, the *lender* has title to the goods instead of the borrower.

Loan-to-Value for Secured Financing

In financing arrangements secured with accounts receivable, the lender will often limit the amount of financing to a specified percentage of the value of the collateral, measured by the *loan-to-value ratio*. For example, in the case of accounts receivable, the loan-to-value ratio may be 75% of the anticipated collections on accounts outstanding up to 30 days, but 60% for accounts outstanding 31 to 60 days. In the case of inventory, a lender may specify a loan-to-value ratio of 60% of finished goods, but 30% of raw materials or work-in-process inventory.

OFF-BALANCE-SHEET FINANCING

A financing transaction in which a debt obligation does not appear on the corporation's balance sheet is referred to as an *off-balance-sheet financing*. Some CFOs believe that off-balance-sheet financing is ignored by market participants in evaluating the corporation's capital structure (e.g., debt-to-equity ratios).

To obtain the desired off-balance-sheet treatment, a corporation can establish a *special-purpose entity* (SPE). An SPE can be a partnership or a trust. SPEs are used for three reasons.

First, an SPE can be used to reduce the cost of debt financing. For example, in an asset securitization transaction, the subject of the next chapter, a corporation seeking financing can sell assets that it has on its balance sheet to an SPE in an arm's-length transaction. The SPE obtains the funds to purchase the assets from the corporation by issuing securities, called *asset-backed securities*. Since the SPE owns the assets, which then becomes the collateral for the securities issued, lenders evaluate the credit quality of the collateral and not the credit quality of the corporation. As a consequence, lower funding costs are possible. For example, a non-investment-grade issuer can obtain funding at investment-grade levels by isolating the assets in the SPE. Also, as explained below, certain types of leasing offer this opportunity.

Second, an SPE allows a corporation to shift risk from itself to third parties willing to accept the risk. An example of this is the use of an SPE to obtain funding for a major project, a financing transaction known as *project*

financing or *project finance*. In this transaction, the lenders to the project look to the cash flow from the project rather than the cash flow of the corporation seeking financing.

Third, the transfer of tax benefits can be accomplished by using an SPE. As explained in Chapter 17, in a lease arrangement, the lessor (i.e., the owner of the leased equipment) is entitled to the tax benefits associated with the ownership of the equipment if the lease qualifies as a true lease for tax purposes. Hence, a corporation that cannot use the tax benefits associated with ownership can transfer those benefits to another party by leasing equipment. In exchange for these tax benefits, the lessor provides a below-market leasing rate that is less than the cost of borrowing funds in order to purchase the equipment.

Fin 46

The issue is whether the SPE should be consolidated with the corporation. GAAP rules for consolidation before January 2003 required that a corporation consolidate if it had a “controlling financial interest.” The definition of “controlling financial interest” was that the firm had a majority voting interest. Hence, under the pre-January 2003 rules set forth by GAAP, a corporation could be the primary beneficiary of the activities of an SPE but, absent a majority voting interest, consolidation was not necessary.

Enron used many SPEs for a variety of illegal purposes. Despite the fact that the other corporations were using SPE for legitimate purposes, the Enron bankruptcy prompted both the FASB and the SEC to reexamine the use of SPEs and the issue of consolidation. The FASB on January 17, 2003 issued FASB Interpretation No. 46 (“Consolidation of Variable Interest Entities”), referred to as “Fin 46,” which set forth a complex set of rules and principles for consolidation of what is referred to as “variable interest entities,” one example being an SPE. If an SPE is consolidated, then the fair market value of the assets is reported on the corporation’s balance sheet as an asset. On the other side of the balance sheet, a fair value for the liability is recorded, as well as the fair market value of the minority interests in the SPE.

Fin 46 is complex and subject to interpretation. Basically, there are four questions that must be asked to determine whether a consolidation is required:

1. Does the corporation have enough equity at risk in the SPE?
2. Is the corporation allowed to make decisions about the activities of the SPE by either voting rights or similar rights?
3. If the SPE incurs a loss, does the corporation have an obligation to absorb that loss?

4. If there are any residual economic benefits expected from the activities of the SPE, does the corporation have the right to receive them?

If the answer to any of the above questions is affirmative, then consolidation is required.

Section 401(a) of the Sarbanes-Oxley Act of 2002

In Chapter 1, we discussed the Sarbanes-Oxley Act of 2002 (SOX). Section 401(a) of SOX and its amendments deal with disclosure in periodic financial reports. With respect to off-balance-sheet transactions, SOX requires that a company in its annual and quarterly filings with the SEC

disclose all material off-balance sheet transactions, arrangements, obligations (including contingent obligations), and other relationships of the issuer with unconsolidated entities or other persons, that may have a material current or future effect on financial condition, changes in financial condition, results of operations, liquidity, capital expenditures, capital resources, or significant components of revenues or expenses.

The amendments to SOX address the lack of transparency of these transactions in a public company's financial disclosure by requiring a discussion of them in a separate section within the management discussion and analysis section in SEC filings that it is reasonable to assume will have an effect on not only the firm's financial condition but other matters material to investors. According to the final regulations,

With a greater understanding of a company's off-balance sheet arrangements and contractual obligations, investors will be better able to understand how a company conducts significant aspects of its business and to assess the quality of a company's earnings and the risks that are not apparent on the face of the financial statements.

BOTTOM LINE

- Intermediate and long-term debt securities include loans and bonds (notes) that have characteristics that can be designed in different ways.

- The all-in-cost of debt is the cost of debt instruments after taking into account the interest and any fees.
- Term loans are negotiated directly between borrower and creditor, where the creditor is typically a commercial bank, an insurance company, or a finance company, and the maturity ranges from 2 to 10 years, though any repayment term is possible.
- In a syndicated bank loan, a group of banks provides funds to the borrower, with the need for a group of banks arising because the amount sought by a borrower may be too large for any one bank to be exposed to the credit risk of that borrower.
- Interest payments on debt may be floating or fixed. For a floating-rate issue, the interest rate reset formula sets forth how the interest rate on the debt obligation will be determined at the interest reset date.
- Debt may be backed by specific pledges of property or may be backed by the general credit of the firm. Some debt may have prior claims over other debt, though all debt securities have prior claim over equity.
- Bonds issued in the United States must comply with U.S. securities laws as regulated by the SEC.
- Bonds can be issued via a firm commitment, best efforts, bought deal, or competitive bidding.
- The basic features or provisions of a bond issue include: (1) denomination, (2) term to maturity, (3) interest rate, (4) security, (5) seniority, and (6) provisions for retirement of debt.
- Bonds may have optionlike features that give the issuer or the bondholder certain rights. Call options, conversion options, and put options are valuable and affect the attractiveness of a bond issue.
- Hybrid securities have features of both bonds and equity. These securities may be treated differently—that is, as debt, as equity, or some of both—for tax, bond rating, and regulatory purposes. Two examples of hybrid securities are convertible securities and trust-preferred securities.
- The bond indenture is the contract between the issuer and the bondholders and consists of provisions that protect the interests of the bondholders.
- A bond issue can be retired by calling it, investors converting it into other securities if granted the option, and buying it back in the marketplace.
- A medium-term note (MTN) is a debt instrument, with the unique characteristic that the securities are offered continuously to investors by an agent of the issuer.
- A CFO seeking to raise funds via a bond offering wants to issue a security with the lowest cost and the flexibility to retire the debt if interest rates fall.

- Short-term financing includes unsecured credit (trade credit, bank financing, commercial paper, securities, and bankers' acceptances) and secured financing.
- Bank financing comes in many forms, including single payment loans, which may arise from simple lending arrangements or from promises to lend in the form of lines of credit, revolving credit agreements, or letters of credit.
- The costs of short-term financing depend on many features of the loan, including the creditworthiness of the borrower, the amount borrowed, any backup line of credit, and the maturity of the loan.
- Off-balance-sheet financing refers to a debt financing that does not appear on the corporation's balance sheet. This is often accomplished using a special-purpose entity, which can be used to realize lower funding costs, shift risks to third parties, and transfer tax benefits.
- The issue associated with off-balance-sheet financing is whether such transactions need to be consolidated on a corporation's balance sheet. For financial reporting purposes, FASB Interpretation No. 46 provides the rules for consolidation; SOX Section 401(a) specifies disclosure requirements for SEC reporting.

Equity Funding

AGENDA

- Item 1* Differentiate between the two types of stock: common and preferred.
- Item 2* Explain what is meant by privately held stock, publicly held stock, and classified stock.
- Item 3* Describe the different types of dividend policy.
- Item 4* Discuss the different views on dividend policy and the views on dividends (irrelevance theory, “bird in the hand” theory, tax preference theory, signaling theory, and agency theory).
- Item 5* Explain why corporations issue preferred stock.
- Item 6* Identify the ways a corporation can repurchase stock.
- Item 7* Describe the different types of preferred stock.

A corporation’s stock may be divided into two major types—common stock and preferred stock. Both may be split into smaller classes of stock. And each of these classes is split into smaller pieces called *shares*. Owners of these shares are referred to as *shareholders* or *stockholders*. Preferred stock and common stock have different rights. Preferred shareholders are given preference over common shareholders: They have the right to receive income ahead of common shareholders. Shareholders receive part of the return on their investment from *dividends*, which are periodic cash payments from the corporation. Dividends promised to preferred shareholders must be paid *before* common shareholders can receive any dividends.

If the company is liquidated, the assets are sold and the proceeds of the sale are distributed to creditors and owners. Preferred shareholders are given preference over common shareholders when liquidation proceeds are distributed among the owners. Preferred shareholders receive the liquidation value of their shares before common shareholders can receive anything. Common stock is the residual ownership of a corporation, *residual* meaning that creditors and preferred shareholders have the right to the income and

assets of a corporation before common shareholders can receive anything. Common shareholders get what is left over.

In this chapter, we take a closer look at the general features of common stock and preferred stock. We also discuss a corporation's dividend policy (in theory and in practice) and stock repurchases.

COMMON STOCK

Residual ownership in a corporation is common stock ownership and is represented by shares. Because the corporation has a perpetual existence granted by its charter, common stock ownership interest—also referred to as *common equity*—is also perpetual.

Common equity is created either by retaining and reinvesting earnings in the corporation or by selling more shares. Whatever is left from earnings after paying what is due the creditors and preferred shareholders may be reinvested in the corporation or paid as dividends to common shareholders. If these residual funds are reinvested in profitable investment opportunities, they increase the value of the corporation, increasing the value of the common stock. If these residual funds are paid to shareholders, the shareholders can reinvest the dividends they receive as they wish.

Privately Held versus Publicly Held Shares

We can classify a corporation according to whether its shares of stock can be traded in financial markets. A corporation whose shares of stock are traded in financial markets is considered a *public corporation* and must comply with federal securities law and register with the Securities and Exchange Commission (SEC). A corporation whose shares cannot be traded in financial markets is considered a *private corporation*.¹

If a corporation has either less than 500 shareholders or less than \$3 million of assets, it can choose not to register, and is referred to as a private corporation or a *privately held corporation*. If it does register with the SEC, it is considered a public corporation. The shares of stock of a public corporation—also referred to as a *publicly held corporation*—can be owned by and traded among the general public. Anyone can buy and sell the shares of stock in a public corporation and these shares can be traded in the financial markets—on national or regional stock exchanges or in the over-the-counter market.

¹ A private corporation whose stock is owned among a very few individuals is referred to as a *closely held corporation* or a *close corporation*. In a close corporation, the stock is owned by a single shareholder or a tightly knit group of shareholders who are active in the management of the firm.

There are several differences between corporations whose shares are publicly traded and those that are privately traded. First, one difference is the stock's marketability. If the shares are publicly traded, they are marketable. Investors can easily buy or sell the shares. If shares are privately held, there may be restrictions as to whom the owner of the stock sells shares, possibly making it difficult to get cash when the investor needs it.

A second difference is the company's access to capital. In general, a publicly traded corporation can raise new capital by issuing more shares to the general public. A privately held corporation may not be able to do this since ownership may be restricted to a few shareholders.

The third difference is confidentiality. A publicly held corporation is required to disclose information to shareholders and the investing public through financial statements, annual reports, and press releases. Securities laws and exchange rules require publicly traded corporations to disclose to investors important information such as a merger, a new product or discovery, the sale of a significant asset, and labor disputes. Private corporations do not have to reveal any information to the public. Therefore, a private corporation has the advantage because it is more difficult for its publicly traded competitors to figure out what it is doing. For example, the two candy companies, Hershey Foods Corporation (Hershey Kisses, Reeses Peanut Butter Cups) and Mars, Incorporated (M&Ms, Milky Way bars), are competitors. Hershey Foods is publicly-traded, whereas Mars is a private company. Mars has access to all of Hershey's financial statements and other disclosures, whereas Hershey has no financial information on Mars.

The fourth difference is the cost of communication. A publicly traded corporation must file annual financial statements with the SEC, prepare and send annual reports to shareholders, and correspond with shareholders. The costs of these communications can add up, in terms of both the direct expenses for accountants, lawyers, and other personnel, and the indirect expense of tying up management's time in shareholders' affairs instead of managing the business. Additionally, the requirements of the Sarbanes-Oxley Act of 2002 and its subsequent rules and regulations have increased the cost of compliance for public companies.

All these differences must be weighed in deciding whether to be a private or a public corporation. There are over 4 million corporations in the United States, but only about 9,000 have publicly traded stock. The fact that we observe some private and some public corporations tells us that the weighing of these factors can go either way.

Corporations do change their status, going from public to private or private to public. It is possible that as a corporation changes—in terms of the ownership, the types of investments it makes, and its need for capital—a change from public to private or private to public may be appropriate. RJR

Nabisco went private in 1989, only to go public once again as RJR Nabisco Holdings two years later when it needed more capital.

Classified Stock

Corporations may have *dual classes* of stock—that is, more than one class of common stock—each with different rights to earnings or voting. There is no limit on the number of different classes of common stock a corporation may issue. The different classes are usually designated Class A, Class B, and so on. There is no rule as to how these classes must be designated.

Often classes of stock that are owned by the family that founded the corporation differ from stock in the same corporation owned by the public. For example, until 1956, Ford Motor Company was a privately held corporation—only Ford family members owned the stock. When the company went public, the Ford family did not want to lose control of the management of the business, so the shares were divided into Class A and Class B. Class A shares are the publicly owned shares and Class B are owned only by Ford family members and their descendants.² Class B shares give their shareholders better voting rights than the Class A shares.

Multiple classes of common stock may also arise from acquisitions.³ For example, General Motors (GM) acquired Hughes Aircraft Co. in 1985. As a condition of the acquisition, Hughes Aircraft shareholders were given a special class of GM stock, designated class H. When GM acquired Electronic Data Systems (EDS) in 1985 it created still another, class E.⁴ General Motors common stock (which does not have a class designation), General Motors Class H common, and General Motors Class E common all had different rights to vote and different rights to dividends. Another example of dual classes of stock is Berkshire Hathaway and its Class A and Class B common stock. Class B shares have 1/30th the interest as a Class A share, but 1/200th the voting power. Further, a Class A share may be converted to 30 Class B shares, but Class B shares have no conversion rights.⁵

Some companies with multiple classes of stock combine these classes to make it easier for investors to understand their equity.⁶ Having two classes,

² In addition to family members and descendants, Class B stock may be owned by trusts or corporations controlled by Ford family members or descendants.

³ Some of these multiple classes were the result of a tax law in effect prior to 1997, which required the acquiring firm to maintain more than 80% voting rights in any merged stock.

⁴ General Motors spun off its EDS division in 1996 by exchanging each GM class E share for one new EDS share, making EDS a publicly traded company once again.

⁵ The motivation for issuing Class B stock was to discourage the creation of unit trusts that would buy Class A shares and then sell unit ownership in this stock.

⁶ Lisa Yoon, "For Some Companies, A+B=1," *CFO.com*, February 13, 2001.

for example, means that dividends and earnings are disclosed for both classes in each financial disclosure. For example, Raytheon consolidated its two classes into one in 2003, simplifying its reporting.

Academic research suggests that companies with dual class stock with differential voting rights do not perform as well as companies with single class stock.⁷ In cases in which the dual classes of stock were created specifically to discourage takeovers, the current focus on corporate governance may encourage companies to remove such classes of stock.⁸

Dividends

A dividend is the cash, stock, or any type of property a corporation distributes to its shareholders. The board of directors may declare a dividend at any time, but dividends are not a legal obligation of the corporation—it is the board's choice. Unlike interest on debt securities, if a corporation does not pay a dividend, there is no violation of a contract and no legal recourse for shareholders.

Most dividends are in the form of cash. Cash dividends are payments made directly to shareholders in proportion to the shares they own. Cash dividends are paid on all outstanding shares of stock. A few companies pay special or extra dividends occasionally—identifying these dividends apart from their regular dividends.

We usually describe the cash dividends that a company pays in terms of *dividends per share*, calculated as follows:

$$\text{Dividends per share} = \frac{\text{Common stock dividends}}{\text{Number of common shares outstanding}}$$

Another way of describing cash dividends is in terms of the percentage of earnings paid out in dividends, referred to as the *dividend payout*. The dividend payout can be expressed in terms of dividends and shares outstanding:

$$\text{Dividend payout} = \frac{\text{Common stock dividends}}{\text{Earnings available to common shareholders}}$$

⁷ Paul A. Gompers, Joy Ishii, and Andrew Metrick, "Extreme Governance: An Analysis of U.S. Dual-Class Companies," March 2006, AFA 2005 Philadelphia Meetings.

⁸ Tara Gry, "Dual-Class Share Structures and Best Practices in Corporate Governance," Economics Division, Parliamentary Information and Research Service, Canada, August 18, 2005, and Andrew Osterland, "Class Struggle," *CFO*, October 1, 2001.

If we divide both the numerator and the denominator by the number of common shares outstanding, we can rewrite the dividend payout as:

$$\text{Dividend payout} = \frac{\text{Dividends per share}}{\text{Earnings per share}}$$

Dividend Reinvestment Plans

Many U.S. corporations allow shareholders to automatically reinvest their dividends in the shares of the corporation paying them. A *dividend reinvestment plan (DRP)* is a program that allows shareholders to reinvest their dividends, buying additional shares of stock of the company instead of receiving the cash dividend. A DRP offers benefits to both shareholders and the corporation. Shareholders buy shares without transactions costs—brokers' commissions—and at a discount from the current market price. The corporation is able to retain cash without the cost of a new stock issue. Alas, the dividends are taxed as income before they are reinvested, even though the shareholders never see the dividend. The result is similar to a dividend cut. Many corporations are finding high rates of participation in DRPs. If so many shareholders want to reinvest their dividends—even after considering the tax consequences—why is the corporation paying dividends? This suggests that there is some rationale, such as signaling (discussed later in this chapter), which compels corporations to pay dividends.

Stock Distributions

In addition to cash dividends, a corporation may provide shareholders with dividends in the form of additional shares of stock or, rarely, some types of property owned by the corporation. When dividends are not in cash, they are usually additional shares of stock. Additional shares of stock can be distributed to shareholders in two ways: paying a stock dividend and splitting the stock.

A *stock dividend* is the distribution of additional shares of stock to shareholders. Stock dividends are generally stated as a percentage of existing share holdings. If a corporation pays a stock dividend, it is not transferring anything of value to the shareholders. The assets of the corporation remain the same and each shareholder's proportionate share of ownership remains the same. All the corporation is doing is cutting its equity pie into more slices and at the same time cutting each shareholder's portion of that equity into more slices. So why pay a stock dividend?

There are a couple of reasons for paying dividends in the form of stock dividends. One is to provide information to the market. A company may

want to communicate good news to the shareholders without paying cash. For example, if the corporation has an attractive investment opportunity and needs funds for it, paying a cash dividend doesn't make any sense—so the corporation pays a stock dividend instead. But is this an effective way of communicating good news to the shareholders? It costs very little to pay a stock dividend—just minor expenses for recordkeeping, printing, and distribution. But if it costs very little, do investors really believe in devices where management is not “putting its money where its mouth is”?

Another reason given for paying a stock dividend is to reduce the price of the stock. If the price of a stock is high relative to most other stocks, there may be higher costs related to investors' transactions of the stock, as in a higher broker's commission. By paying a stock dividend—which slices the equity pie into more pieces, the price of the stock should decline. Let's see how this works. Suppose an investor owns 1,000 shares, each worth \$50 per share, for a total investment of \$50,000. If the corporation pays the investor a 5% stock dividend, the investor then owns 1,050 shares after the dividend. Is there any reason for your holdings to change in value? Nothing economic has gone on here—the company has the same assets, the same liabilities, and the same equity—total equity is just cut up into smaller pieces. There is no reason for the value of the portion of the equity this investor owns to change. But the price *per share* should decline: from \$50 per share to \$47.62 per share. The argument for reducing share price works only if the market brings down the price substantially, from an unattractive trading range to a more attractive trading range in terms of reducing brokerage commissions and enabling small investors to purchase even lots of 100 shares.

A stock split is something like a stock dividend. A *stock split* splits the number of existing shares into more shares. For example, in a 2:1 split—referred to as “two for one”—each shareholder gets two shares for every one owned. If an investor owns 1,000 shares and the stock is split 2:1, the investor then owns 2,000 shares after the split. Has the portion of the investor's ownership in the company changed? No, the investor now simply owns twice as many shares—and so does every other shareholder. If the investor owned 1% of the corporation's stock before the split, the investor still owns 1% after the split.

So why split? Like a stock dividend, the split reduces the trading price of shares. If an investor owns 1,000 shares of the stock trading for \$50 per share prior to a 2:1 split, the shares should trade for \$25 per share after the split.

Aside from a minor difference in accounting, stock splits and stock dividends are essentially the same.⁹ A 2:1 split has the same effect on a stock's

⁹ The stock dividend requires a shift within the stockholders' equity accounts, from retained earnings to paid-in capital, for the amount of the distribution, whereas the stock split requires only a memorandum entry.

price as a 100% stock dividend, a 1.5 to 1 split has the same effect on a stock's price as a 50% stock dividend, and so on.¹⁰

How can investors tell what the motivation is behind stock dividends and stock splits? They cannot, but they can get a general idea of how investors interpret these actions by looking at what happens to the corporation's share price when a corporation announces its decision to pay a stock dividend or split its stock, or reverse split. If the share price tends to go up when the announcement is made, the decision is probably good news; if the price tends to go down, the stock dividend is probably bad news. This is supported by evidence that indicates corporations' earnings tend to increase following stock splits and dividends.¹¹

The share price of companies announcing stock distributions and stock splits generally increases at the time of the announcement.¹² The most likely explanation is that this distribution is interpreted as good news—that management believes that the future prospects of the company are favorable or that the share price is more attractive to investors.

Dividend Policy

A dividend policy is a corporation's decision about the payment of cash dividends to shareholders. There are several basic ways of describing a corporation's dividend policy:

- No dividends.
- Constant growth in dividends per share.
- Constant payout ratio.
- Low regular dividends with periodic extra dividends.

¹⁰ The basis of the accounting rules is related to the reasons behind the distribution of additional shares. If firms want to bring down their share price, they tend to declare a stock split; if firms want to communicate news, they often declare a stock dividend.

¹¹ See, for example, Maureen McNichols and Ajay Dravid, "Stock Dividends, Stock Splits, and Signaling," *Journal of Finance* (July 1990), pp. 857–879.

¹² The stock price typically increases by 1 to 2% when the split or stock dividend is announced. When the stock dividend is distributed or the split is effected (on the "ex" date), the share's price typically declines according to the amount of the distribution. Suppose a firm announces a 2:1 split. Its share price may increase by 1 to 2% when this is announced, but when the shares are split, the share price will go down to approximately half of its pre-split value. See, for example, Mark Grinblatt, Ronald Masulis, and Sheridan Titman, "The Valuation Effects of Stock Splits and Stock Dividends," *Journal of Financial Economics* (December 1984), pp. 461–490.

The corporations that typically do not pay dividends are those that are generally viewed as younger, faster growing companies. For example, Microsoft Corporation was founded in 1975 and went public in 1986, but it did not pay a cash dividend until January 2003.

A common pattern of cash dividends tends to be the constant growth of dividends per share. Another pattern is the constant payout ratio. Many companies in the food processing industry, such as Kellogg and Tootsie Roll Industries, pay dividends that are a relatively constant percentage of earnings. Some companies display both a constant dividend payout and a constant growth in dividends. This type of dividend pattern is characteristic of large, mature companies that have predictable earnings growth—the dividends growth tends to mimic the earnings growth, resulting in a constant payout.

U.S. corporations that pay dividends tend to pay either constant or increasing dividends per share. Dividends tend to be lower in industries that have many profitable opportunities to invest their earnings. But as a company matures and finds fewer and fewer profitable investment opportunities, a greater portion of its earnings are paid out in dividends.

Many corporations are reluctant to cut dividends because the corporation's share price usually falls when a dividend reduction is announced. For example, the U.S. auto manufacturers cut dividends during the recession in the early 1990s. As earnings per share declined the auto makers did not cut dividends until EPS were negative—and in the case of General Motors, not until it had experienced two consecutive loss years. But as earnings recovered in the mid-1990s, dividends were increased.¹³ Corporations tend to raise their regular quarterly dividend only when they are sure they can keep it up in the future. By giving a special or extra dividend, the corporation is able to provide more cash to the shareholders without committing itself to paying an increased dividend each period into the future.

There is no general agreement whether dividends should or should not be paid. Here are several views:

- *The Dividend Irrelevance Theory:* The payment of dividends does not affect the value of the firm since the investment decision is independent of the financing decision.
- *The “Bird in the Hand” Theory:* Investors prefer a certain dividend stream to an uncertain price appreciation.
- *The Tax-Preference Explanation:* Due to the way in which dividends are taxed, investors should prefer the retention of funds to the payment of dividends.

¹³ General Motors increased dividends until cutting them once again in 2006 as it incurred substantial losses.

- *The Signaling Explanation:* Dividends provide a way for the management to inform investors about the firm's future prospects.
- *The Agency Explanation:* The payment of dividends forces the firm to seek more external financing, which subjects the firm to the scrutiny of investors.

The Dividend Irrelevance Theory

The dividend irrelevance argument was developed by Merton Miller and Franco Modigliani.¹⁴ Basically, the argument is that if there is a *perfect market*—no taxes, no transactions costs, no costs related to issuing new securities, and no costs of sending or receiving information—the value of the corporation is unaffected by payment of dividends.

How can this be? Suppose investment decisions are fixed—that is, the company will invest in certain projects *regardless* of how they are financed. The value of the corporation is the present value of all future cash flows of the company—which depend on the investment decisions that management makes, *not* on how these investments are financed. If the investment decision is fixed, whether a corporation pays a dividend or not does not affect the value of the corporation.

A corporation raises additional funds either through earnings or by selling securities—sufficient to meet its investment decisions and its dividend decision. The dividend decision therefore affects only the financing decision—how much capital the company has to raise to fulfill its investment decisions.

The Miller and Modigliani argument implies that the dividend decision is a residual decision. If the company has no profitable investments to undertake, the firm can pay out funds that would have gone to investments to shareholders. And whether or not the company pays dividends is of no consequence to the value of the company. In other words, dividends are irrelevant.

But CFOs don't live in a perfect world with a perfect market. Are the imperfections (taxes, transactions costs, etc.) enough to alter the conclusions of Miller and Modigliani? It isn't clear.

The “Bird in the Hand” Theory

A popular view is that dividends represent a *sure thing* relative to share price appreciation. The return to shareholders is comprised of two parts: the return from dividends—the *dividend yield*—and the return from the change in the share price—the *capital yield*. Corporations generate earnings and

¹⁴ Merton Miller and Franco Modigliani, “Dividend Policy, Growth and the Valuation of Shares,” *Journal of Business* (October 1961), pp. 411–433.

can either pay them out in cash dividends or reinvest earnings in profitable investments, increasing the value of the stock and, hence, share price. Once a dividend is paid, it is a certain cash flow. Shareholders can cash their quarterly dividend checks and reinvest the funds. But an increase in share price is not a sure thing. It becomes a sure thing only when the share's price increases over the price the shareholder paid and he or she sells the shares.

We can observe that prices of dividend-paying stocks are less volatile than non-dividend-paying stocks. But are dividend-paying stocks less risky because they pay dividends? Or are less risky firms more likely to pay dividends? Most of the evidence supports the latter. Companies that have greater risk—business risk, financial risk, or both—tend to pay little or no dividends. Companies whose cash flows are more variable tend to avoid large dividend commitments that they could not satisfy during periods of poorer financial performance.

The Tax-Preference Explanation

If dividend income is taxed at the same rates as capital gain income, investors may prefer capital gains because of the time value of money: Capital gains are taxed only when realized—that is, when the investor sells the stock—whereas dividend income is taxed when received. If, however, dividend income is taxed at rates higher than that applied to capital gain income, investors should prefer stock price appreciation to dividend income because of both the time value of money and the lower rates.

Historically, capital gain income has been taxed in the United States at rates lower than that applied to dividend income for individual investors. However, the current situation for individuals is that dividend income and capital gain income are taxed at the same rates.¹⁵ Even with the same rates applied to income, capital gain income is still preferred because the tax on any stock appreciation is deferred until the stock is sold.

But the tax impact is different for different types of shareholders. A corporation receiving a dividend from another corporation may take a *dividends received deduction*—a deduction of a large portion of the dividend income.¹⁶ Therefore, corporations pay taxes on a small portion of their dividend income. Still other shareholders may not even be taxed on dividend

¹⁵ The Jobs & Growth Tax Relief Reconciliation Act of 2003 lowered the tax rate individuals pay on dividends to 15% or 5%, depending on the individual's other income, at the same time lowering the tax rate on capital gains to the same 15% or 5% rates. Though these tax rate cuts were intended to expire in 2008, they were extended by the Tax Relief and Health Care Act of 2006

¹⁶ As explained in Chapter 7, the dividends received deduction ranges from 70% to 100%, depending on the ownership relation between the two corporations.

income. For example, a pension fund beneficiary does not pay taxes on the dividend income it gets from its investments (these earnings are eventually taxed when the pension is paid out to the employee after retirement).

Even if dividend income were taxed at rates higher than that of capital gains, investors could take investment actions that affect this difference. First, investors that have high marginal tax rates may gravitate toward stocks that pay little or no dividends. This means the shareholders of dividend-paying stocks have lower marginal tax rates. This is referred to as a *tax clientele*—investors who choose stocks on the basis of the taxes they have to pay. Second, investors with high marginal tax rates can use legitimate investment strategies—such as borrowing to buy stock and using the deduction from the interest payments on the loan to offset the dividend income in order to reduce the tax impact of dividends.¹⁷

The Signaling Explanation

Companies that pay dividends seem to maintain a relatively stable dividend, either in terms of a constant or growing dividend payout or in terms of a constant or growing dividend per share. And when companies change their dividend—either increasing or reducing (“cutting”) the dividend—the price of the company’s shares seems to be affected: When a dividend is increased, the price of the company’s shares typically goes up; when a dividend is cut, the price usually goes down. This reaction is attributed to investors’ perception of the meaning of the dividend change: Increases are good news, decreases are bad news.

The board of directors is likely to have some information that investors do not have; a change in dividend may be a way for the board to signal this private information. Because most boards of directors are aware that when dividends are lowered, the price of a share usually falls, most investors do not expect boards to increase a dividend unless they thought the company could maintain it into the future. Realizing this, investors may view a dividend increase as the board’s increased confidence in the future operating performance of the firm.

¹⁷ Several strategies that can be used to reduce the taxes on dividend income are discussed by Merton Miller and Myron Scholes in “Dividend and Taxes,” *Journal of Financial Economics* (1979), pp. 333–364. However, Pamela Peterson, David Peterson, and James Ang, in their article entitled “Direct Evidence on the Marginal Rate of Taxation on Dividend Income,” *Journal of Financial Economics* (1985), pp. 267–282, document that investors do not appear to take advantage of these strategies and end up paying substantial taxes on dividend income.

The Agency Explanation

As explained in Chapter 1, the relation between the owners and the managers of a firm is an agency relationship: The owners are the principals and the managers are the agents. Management is charged with acting in the best interests of the owners. Nevertheless, there are possibilities for conflicts between the interests of the two. If the firm pays a dividend, the CFO may be forced to raise new capital outside of the firm—that is, issue new securities instead of using internally generated capital—subjecting them to the scrutiny of equity research analysts and other investors. This extra scrutiny helps reduce the possibility that managers will not work in the best interests of the shareholders. But issuing new securities is not costless. There are costs of issuing new securities—flotation costs. In “agency theory speak,” these costs are part of *monitoring costs*—incurred to help monitor the managers’ behavior and insure behavior is consistent with shareholder wealth maximization.

The payment of dividends also reduces the amount of free cash flow under control of management. Free cash flow is the cash in excess of the cash needed to finance profitable investment opportunities. A profitable investment opportunity is any investment that provides the company with a return greater than what shareholders could get elsewhere on their money—that is, a return greater than the shareholders’ opportunity cost.

Because free cash flow is the cash flow left over after all profitable projects are undertaken, the only projects left are the unprofitable ones. Should free cash be reinvested in the unprofitable investments or paid out to shareholders? Of course if boards make decisions consistent with shareholder wealth maximization, any free cash flow should be paid out to shareholders since—by the definition of a profitable investment opportunity—the shareholders could get a better return investing the funds they receive.

If the company pays a dividend, funds are paid out to shareholders. If the company needs additional funds, they could be raised by issuing new securities, and if the shareholders wish to reinvest the funds received as dividends in the firm, they could buy these new securities. One view of the role of dividends is that the payment of dividends therefore reduces the cash flow in the hands of management, reducing the possibility that managers will invest funds in unprofitable investment opportunities.

Summing Up: To Pay Dividends or Not

We can figure out reasons why a company should or should not pay dividends, but not why they actually do or do not—this is the “dividend puzzle.”

zle.”¹⁸ But we do know from looking at dividends and the market’s reaction to them that:

- If a company increases its dividends or pays a dividend for the first time, this is viewed as good news—its share price increases.
- If a company decreases its dividend or omits it completely, this is viewed as bad news—its share price declines.

That’s why CFOs must be aware of the relation between dividends and the value of the common stock in establishing or changing dividend policy.

Stock Repurchases

Corporations have repurchased their common stock from their shareholders. A corporation repurchasing its own shares is effectively paying a cash dividend, with one important difference: taxes. Cash dividends are ordinary taxable income to the shareholder. A firm’s repurchase of shares, however, results in a capital gain or loss for the shareholder, depending on the price paid when they were originally purchased. If the shares are repurchased at a higher price, the difference may be taxed as capital gains, which may be taxed at rates lower than ordinary income.

The company may repurchase its own stock by any of three methods: (1) a tender offer, (2) open market purchases, and (3) a targeted block repurchase.

A *tender offer* is an offer made to all shareholders, with a specified deadline and a specified number of shares the corporation is willing to buy back. The tender offer may be a fixed price offer, where the corporation specifies the price it is willing to pay and solicits purchases of shares of stock at that price. A tender offer may also be conducted as a *Dutch auction*, in which the corporation specifies a minimum and a maximum price, soliciting bids from shareholders for any price within this range at which they are willing to sell their shares. After the corporation receives these bids, they pay all tendering shareholders the maximum price sufficient to buy back the number of shares they want. A Dutch auction reduces the chance that the firm pays a price higher than needed to acquire the shares. Dutch auctions are gaining in popularity relative to fixed-price offers. For example, Wendy’s International announced in October 2006 that it would buy back shares in a Dutch auction tender offer. In this offer, the company specified the range of prices it is willing to pay—in this case \$33.00 to \$36.00 per share—and the number of shares. The company then allowed the auction mechanism to work to determine the price. As a result of this auction, Wendy’s bought back 22.4

¹⁸ The phrase “dividend puzzle” originates from Fischer Black, “The Dividend Puzzle,” *Journal of Portfolio Management* (Winter 1976), pp. 5–8.

million shares at \$35.75 per share in November 2006, representing 19% of the company's outstanding common stock. There were 27.9 million shares tendered, but only 22.4 million shares at or below the purchase price.¹⁹

A corporation may also buy back shares directly in the open market. This involves buying the shares through a broker. A corporation that wants to buy shares may have to spread its purchases over time so as not to drive the share's price up temporarily by buying large numbers of shares.

The third method of repurchasing stock is to buy it from a specific shareholder. This involves direct negotiation between the corporation and the shareholder. This method is referred to as a *targeted block repurchase*, since there is a specific shareholder (the "target") and there are a large number of shares (a "block") to be purchased at one time. Targeted block repurchases, also referred to as "greenmail," were used in the 1980s to fight corporate takeovers.

Corporations repurchase their stock for a number of reasons. First, a repurchase is a way to distribute cash to shareholders at a lower cost to both the firm and the shareholders than dividends. If capital gains are taxed at rates lower than ordinary income, which until recently has been the case with U.S. tax law, repurchasing is a lower-cost way of distributing cash. However, since shareholders have different tax rates—especially when comparing corporate shareholders with individual shareholders—the benefit is mixed. The reason is that some shareholders are tax-free (e.g., pension funds), some shareholders are taxed on only a portion of dividends (e.g., corporations receiving dividends from other corporations), and some shareholders are taxed on the full amount of dividends (e.g., individual taxpayers).

Another reason to repurchase stock is to increase earnings per share. A company that repurchases its shares increases its earnings per share simply because there are fewer shares outstanding after the repurchase. But there are two problems with this motive. First, cash is paid to the shareholders, so less cash is available for the corporation to reinvest in profitable projects. Second, because there are fewer shares, the earnings pie is sliced in fewer pieces, resulting in higher earnings per share. The individual "slices" are bigger, but the pie itself remains the same size.

Looking at how share prices respond to gimmicks that manipulate earnings, there is evidence that a company cannot fool the market by playing an earnings-per-share game. The market can see through the earnings per share to what is really happening and that is that the firm will have less cash to invest.

Still another reason for stock repurchase is that it could tilt the debt-equity ratio so as to increase the value of the company. By buying back stock—thereby reducing equity—the company's assets are financed to a greater degree by

¹⁹ Wendy's News Release, "Wendy Announces Final Results of its Modified 'Dutch Auction' Tender Offer," November 22, 2006.

debt. Does this seem wrong? It is not. To see this, suppose a corporation has a balance sheet consisting of assets of \$100 million, liabilities of \$50 million, and \$50 million of equity. That is, the corporation has financed 50% of its assets with debt, and 50% with equity. If this corporation uses \$20 million of its assets to buy back stock worth \$20 million, its balance sheet will have assets of \$80 million financed by \$50 million of liabilities and \$30 million of equity. It now finances 62.5% of its assets with debt and 37.5% with equity.

If financing the firm with more debt is good—that is, the benefits from deducting interest on debt outweigh the cost of increasing the risk of bankruptcy—repurchasing stock may increase the value of the firm. But there is the flip-side to this argument: Financing the firm with more debt may be bad if the risk of financial distress—difficulty paying legal obligations—outweighs the benefits from tax deductibility of interest.

So, repurchasing shares from this perspective would have to be judged on a case-by-case basis to determine if it is beneficial or detrimental.

One more reason for a stock repurchase is that it reduces total dividend payments—without seeming to. If the CFO cuts down on the number of shares outstanding, the corporation can still pay the same amount of dividends *per share*, but the *total* dividend payments are reduced. If the shares are correctly valued in the market (there is no reason to believe otherwise), the payment for the repurchased shares equals the reduction in the value of the firm—and the remaining shares are worth the same as they were before.

Some argue that a repurchase is a signal about future prospects. That is, by buying back the shares, the management is communicating to investors that the company is generating sufficient cash to be able to buy back shares. But does this make sense? Not really. If the company has profitable investment opportunities, the cash could be used to finance these investments, instead of paying it out to the shareholders.

A stock repurchase may also reduce agency costs by reducing the amount of cash the management has on hand. Similar to the argument suggested for dividend payments, repurchasing shares reduces the amount of free cash flow and, hence, reduces the possibility that management will invest it unprofitably. Many companies use stock buybacks to mitigate the dilution resulting from executive stock options, as well as to shore up their stock price. Companies in the S&P 500, for example, repurchased a record dollar amount of shares in 2005 and 2006, as much as they spent on capital expenditures.²⁰ The effect of these buybacks has been to increase earnings per share for the S&P 500 by 20% in 2006.

²⁰ “S&P 500 Companies Using Excess Cash to Reduce Share Count,” Standard & Poor’s Press Release, September 19, 2005, “S&P 500 3rd Quarter Buybacks at \$110 Billion,” Standard & Poor’s Press Release, November 27, 2006, and Stephen Taub, “Stock Buybacks at ‘Unprecedented Level,’” *CFO.com*, September 18, 2006.

Repurchasing shares tends to shrink the firm: Cash is paid out and the value of the firm is smaller. Can repurchasing shares be consistent with wealth maximization? Yes. If the best use of funds is to pay them out to shareholders, repurchasing shares maximizes shareholders' wealth. If the firm has no profitable investment opportunities, it is better for a firm to shrink by paying funds to the shareholders than to shrink by investing in lousy investments.

So how does the market react to a company's intention to repurchase shares? A number of studies have looked at how the market reacts to such announcements. In general, the share price goes up when a firm announces it is going to repurchase its own shares. It is difficult to identify the reason the market reacts favorably to such announcements since so many other things are happening at the same time. By piecing bits of evidence together, however, we see that it is likely that investors view the announcement of a repurchase as good news—a signal of good things to come.

PREFERRED STOCK

Some corporations also issue preferred stock: a form of ownership that has preference over common stock ownership. Like common stock, preferred stock also represents equity.

Preferred shareholders have a claim on income and assets ahead of that of common shareholders. Preferred shareholders are promised a dividend that must be paid before common shareholders receive any dividends. The consequences of not paying the preferred stock dividend are not as drastic as not paying, say, interest on a debt obligation: Unlike creditors, preferred shareholders do not have a legal claim to receive the dividend—they cannot force the corporation into bankruptcy for failure to pay.

However, if the business is liquidated—all the assets sold and the proceeds used to pay off all the creditors and owners—the preferred shareholders get all that's coming to them before common shareholders get anything. While few corporations are actually liquidated, this prior claim provides preferred shareholders with an advantage in the reorganization of firms in distress or bankruptcy. The rating agencies assigning ratings to corporate bond issues also rate preferred stock issues.

Just as there may be different classes of common stock, there also may be different classes of preferred stock, each with different dividend rates and rights. Some classes of preferred stock are junior to others—they wait in line behind owners of more senior preferred issues in the case of dividends and liquidation. Nevertheless, all preferred shareholders have preference over the common shareholders. While common stock is never issued with a maturity

date, preferred stock may be issued with or without a maturity date. Preferred stock issued without a maturity date is called *perpetual preferred stock*.

Features of Preferred Stock

When issuing preferred stock, the CFO, with the help of an investment banker, determines the features of the preferred stock. These features affect the cost of the stock, the issuer's flexibility in changing its capital structure, and the role of preferred shareholders in the governance of the company, among other things. We'll first take a look at the different preferred stock features that are typically used. Then we'll see how these features can be packaged together to provide a source of financing that meets the issuer's needs and the investors' preferences.

Par and Liquidation Values

Preferred stock may have a par value, though it is not legally required. Nevertheless, it is convenient to have some value for accounting purposes. Some corporations specify a *stated value* for the stock—an arbitrary value, say \$100. Each preferred stock does have a *liquidation value*—the amount that preferred shareholders are paid in the event the corporation is liquidated and there remain sufficient assets to pay off this value. Often, the liquidating value is equal to the stated or par value of the stock.

Dividends

Although a corporation's board of directors declares a dividend on its preferred stock, it is not a legal obligation. That is, if a corporation does not pay the dividend, preferred shareholders cannot legally force payment. Nevertheless, almost all corporations pay their specified preferred dividend. When dividends are paid, preferred dividends must be paid first; what remains may be paid as dividends to common shareholders. Most preferred share dividends are paid in cash, though a few preferred stock issues allow the firm issuing them to pay preferred dividends in cash or shares of stock.

Most preferred dividends are paid quarterly, though monthly, semi-annual, and annual dividends are possible. And preferred dividends may be paid at either a fixed or floating rate per period. Fixed dividends are expressed as either a percentage of the par value or a fixed dollar amount per period.

There are different types of preferred stock that pay a floating-rate dividend. With *adjustable-rate preferred stock* (ARPS) the dividend rate is typically fixed quarterly and based on a predetermined spread from the high-

est of three points on the Treasury yield curve. The predetermined spread is called the *dividend reset spread*. Most adjustable-rate preferred stock is perpetual, with a floor (i.e., a minimum rate) and a cap (i.e., a maximum or ceiling rate) imposed on the dividend rate of most issues. This maximum and minimum dividend rate feature is referred to as a *collar*. From the perspective of the issuer, a collar's maximum ensures that the costs of financing with preferred stock are limited; from the perspective of the investors, a collar's minimum ensures that the return on the preferred stock has a lower limit.

Auction preferred stock is designed to overcome the problem of preferred stock trading below par value. The dividend rate on auction preferred stock is set periodically, as with adjustable-rate preferred stock, but it is established through an auction process. (More specifically, it is through a Dutch auction.) Participants in the auction consist of current holders and potential buyers. The dividend rate that participants are willing to accept reflects current market conditions.

Remarketed preferred stock is preferred stock where the dividend rate is determined periodically by a remarketing agent who resets the dividend rate so that any preferred stock can be tendered at par and be resold (remarketed) at the original offering price. Typically, an investor has the choice of dividend resets every seven days or every 49 days. Since the mid-1980s, auction preferred stock and remarketed preferred stock have become the dominant type of preferred stock issued.

Cumulative versus Noncumulative Dividends

Because there is no legal requirement to pay dividends to preferred shareholders, these shareholders want some assurance that their dividend is not skipped and the funds paid instead to common shareholders. But there is a way to insure that common shareholders do not take advantage of the preferred shareholders' lack of legal claim on dividends.

With *cumulative preferred stock*, any dividend not paid in one period must be paid the next period before any other dividend for that class of preferred stock is paid and before any common stock dividend is paid. With *noncumulative preferred stock*, any dividend not paid in a period is not paid in any other period—it is simply forgotten and does not affect the preferred or common dividend in any future period.

If a preferred stock dividend is cumulative, any dividend passed over in one period is carried over year to year. The passed over dividend is referred to as the *arrearage* and the preferred stock dividend is said to be in *arrears*. Most preferred stock issued in the United States is cumulative preferred stock.

Participating versus Nonparticipating

Preferred shareholders may also share in the earnings of the firm, along with the common shareholders. If the preferred stock is *participating*, preferred shareholders receive a share of the earnings according to some prescribed formula. This share of earnings is either in addition to a stated preferred dividend or varies according to the common stock dividend.

There are very few participating preferred stock issues. There are two reasons for this. First, preferred stock originated as a substitute for debt in cases where corporations were in poor financial condition. Because the prospects for a corporation issuing preferred stock are viewed as dim, so is the value of participating in the corporation's future earnings. Preferred shareholders prefer to receive their promised dividend, rather than to gamble on an uncertain share of earnings.

Second, participating preferred stock reduces the benefits to common shareholders. If the corporation does poorly, common shareholders are protected on the downside by limited liability. If the corporation does well, common shareholders do not have to share the good earnings with others. The corporation simply pays the bondholders and preferred shareholders the promised interest or dividend and no more, keeping the rest. Participating preferred shares would limit this leveraging effect.

Convertibility

A preferred stock may be exchangeable for common shares—called a *convertible preferred stock*. Such a conversion feature gives the shareholder the right to convert the preferred shares into common shares at a predetermined rate of exchange.

Many companies have issued *mandatory convertible preferred stock*. This type of stock requires the investor to convert the preferred shares into common shares within a specified period of time—say, five years. From the perspective of the issuer, mandatory convertible preferred is attractive since it releases the corporation from the obligation to pay preferred dividends and is, in effect, a deferred issue of common shares. From the perspective of the investor, mandatory convertible preferred provides the opportunity to convert but only within a specific period and is much like a common stock with a set dividend rate for a limited period of time.

Callability

As explained earlier, preferred stock can be issued with or without a maturity date. If the CFO wants to retire a preferred stock issue, she can do so by

purchasing the stock in the open market or exchanging preferred shares for another security, such as common shares, with a conversion feature.

If the stock is callable, the CFO has another alternative: Exercise the right to call it—buy it—from the investor. *Callable preferred stock* gives the CFO the right to buy it from the shareholder at a predetermined price. If the CFO wants to buy back the stock by using the call—referred to as *exercising* the call—the company pays the specified *call price*. The call price may be a set amount forever, or may change according to a preset schedule. The call price is generally greater than or equal to the stated or par value of the stock.

Voting Rights

The vast majority of preferred stock issues do not include voting rights. Instead, preferred shareholders generally have *contingent voting rights*—voting rights that become active only when the corporation fails to pay the promised preferred stock dividend. Contingent voting rights may be designed in any manner. But the typical voting right is triggered once the dividends are in arrears and is limited to voting on representation on the board of directors and the issuance of other securities. For example, the New York Stock Exchange requires that all preferred stock issues have contingent voting rights that allow preferred shareholders the right to vote for at least two members of the board of directors as long as dividends are in arrears.

Sinking Funds

Because there is no legal obligation to pay the preferred dividend and because bondholders and other creditors get the first crack at a company's income and liquidation rights, preferred shareholders want some assurance they will receive preferred stock dividends. A corporation can provide this assurance in the form of a *sinking fund* provision. In fact, almost all preferred stock has a sinking fund provision. We explained the sinking fund provision in the previous chapter in the context of long-term debt.

Packaging Features

In designing a preferred stock issue, a CFO will combine many of the features we just described. The preferred share issue must be packaged in a way that is attractive to investors and at a reasonable cost. Features that give the issuer flexibility, such as a call feature, introduce uncertainty for investors. Investors do not know when (or if) the firm will call the issue. Because investors do not like risk, they will demand a greater return on callable preferred shares to compensate for the additional risk implicit in their uncertainty.

Providing a greater return increases the issuer's cost. Features that give the investor something of additional value, such as a conversion feature, lower the issuer's cost. Investors are willing to accept a lower return in exchange for convertibility and therefore the issuer's cost of capital is lower. Like common stock, dividends received by corporations are partially excluded from taxation. Because most investors in preferred stock are corporations, the dividend received deduction lowers the return demanded by investors, lowering the issuing corporation's cost of financing.

Packaging a new issue of preferred stock requires considering investors' need for greater returns and lower risk and the issuer's need for greater flexibility and lower costs.

Corporate Use of Preferred Stock

Why would a CFO recommend the issuance of preferred stock? One advantage of using preferred stock as a source of capital is that, in general, the firm must pay only a fixed amount in dividends, leaving the upside potential in earnings to be reaped by common shareholders. Another advantage is that the voting control of common shareholders is not diluted, as it would be if common shares were issued. Still another advantage is the cost of preferred stock. Preferred stock is considered less risky than common stock; therefore its cost to the issuer should be less than that of common stock. Relative to issuing debt, preferred stock is more expensive since the interest paid on debt is deductible for tax purposes and the dividends paid on preferred stock are not deductible.

Mitigating this cost somewhat is the fact that, as explained in Chapter 7, a large portion (currently 70% to 100%) of the dividends received by corporate owners of preferred stock is excluded from taxable income, which therefore reduces the yields that corporate investors demand on the stock. The purpose of this provision is to mitigate the effect of the double taxation of corporate earnings. There are two implications of this tax treatment of preferred stock dividends. First, the major buyers of preferred stock are the treasurers of corporations seeking tax-advantaged investments. Second, the cost of preferred stock issuance is lower than it would be in the absence of the tax provision, because the tax benefits are passed through to the issuer by the willingness of buyers to accept a lower dividend rate.

A disadvantage of preferred stock, relative to common stock, is that it has a claim on income and assets of the corporation that is senior to that of common shareholders. The corporation must pay the dividends owed preferred shareholders before it pays dividends to common shareholders.

BOTTOM LINE

- Stock represents ownership in a corporation in units called shares.
- There are two types of stock: preferred and common. Both are forms of equity, but have different priorities with respect to their claim on the firm's income and assets.
- Part of shareholders' return is in the form of cash payments called dividends.
- Whether a corporation should pay dividends is debatable, given that even with similar tax rates on dividend income and capital gain income, capital gains are preferred because of the time value of money. Some believe that dividends serve a purpose: either providing information about the firm's future prospects or forcing the corporation to sell more securities to raise the money to pay the dividends.
- Common stock represents ownership that is last to receive any income and any assets if the firm is liquidated. If the firm is liquidated, common shareholders have to wait until all claimants, such as creditors and preferred shareholders, are satisfied before they receive anything. Common shareholders are the ultimate owners of the corporation.
- Besides cash dividends, firms may distribute additional shares of stock to shareholders through a stock dividend or a stock split. While distributing additional shares does not change the value of the stock, the announcement of the distribution may provide information about management's expectations of the firm's future prospects.
- Corporations can repurchase shares in the open market, use a tender offer, or buy shares in a targeted block repurchase. Corporations can repurchase shares either to change their capital structure, reduce dividend payments, signal future prospects, or reduce free cash flow.
- Common shareholders get a return from their investment in the form of dividends and any increase (or decrease) in the market value of their share. But dividends are not a sure thing. The corporation is not obligated to pay dividends to common shareholders.
- Some preferred stock has some of the features of common stock—a perpetual security with dividends. But preferred stock also shares some of the features of long-term debt, such as convertibility, callability, and sinking funds. There is some preferred stock with a maturity date.
- Preferred dividends can be specified a number of ways: fixed versus adjustable, cumulative versus noncumulative, and participating versus nonparticipating. The most common types of preferred stock with respect to the dividend feature are auction preferred stock and remarketing preferred stock.

- Similar to notes and bonds, preferred stock can be convertible into common stock and callable.
- Unlike common shareholders, preferred shareholders do not have a say in the corporation. Only in extreme circumstances do preferred shareholders vote for representation on the board of directors. Therefore, features such as cumulative dividends and contingent voting rights have developed to protect the preferred shareholders' rights.

Structured Financing: Asset Securitization and Structured Notes

AGENDA

- Item 1* Explain what is meant by a structured financing.
- Item 2* Identify the elements that generally characterize a structured finance transaction.
- Item 3* Describe what is meant by asset securitization.
- Item 4* Explain the reasons why a CFO will use a securitization rather than issuing a corporate bond.
- Item 5* Explain the role of the special-purpose vehicle in a securitization transaction.
- Item 6* Describe the different forms of credit enhancement in a securitization transaction.
- Item 7* Explain what a structured note is.
- Item 8* Explain why derivatives are used in the creation of a structured note.
- Item 9* Identify the benefits to the issuing corporation for creating a structured note.
- Item 10* Describe the reasons why institutional investors are motivated to invest in structured notes.
- Item 11* Explain the steps associated with the creation of a structured note.

As an alternative to the traditional sources of funds, including corporate bonds and equity issuance, a CFO can raise funds via a structured finance transaction. Structured finance consists of funding products and/or financing processes that are customized for the entity raising the capital in terms of cash flows, risk sharing, or other features.¹ Hence, to meet this requirement,

¹ See Frank J. Fabozzi, Henry Davis, and Moorad Choudhry, *Introduction to Structured Finance* (Hoboken, NJ: John Wiley & Sons, 2007), p. 1.

existing products and techniques must be engineered into a tailor-made product or process. Thus, structured finance is a flexible financial engineering tool.

A large part of what we consider structured finance in today's markets involves asset securitization. Other forms of structured finance include structured notes, which is a form of debt financing that includes embedded options.

Though there are many structured finance products and processes, they share some basic characteristics:

- Complex products or processes that involve a pool of underlying assets.
- Liabilities whose cash flows are either linked to a pool of assets or referenced to a specified index, most likely divided into classes referred to as tranches.
- Embedded derivatives.
- A special-purpose entity that links the pool of assets, the liabilities, and the derivatives that provides a legal entity apart from the originator of the structured finance product.²

The key is that the structured finance product or process serves to rearrange the cash flows of the underlying assets into different securities that may have different cash flow and risk characteristics.

In this chapter, we focus on asset securitization, which is the most widely used form of structured financing, and structured notes.

ASSET SECURITIZATION

In Chapter 3, where we discuss debt instruments, we describe secured debt instruments whose credit standing is supported by a lien on specific assets. However, with traditional secured bonds, it is necessary for the issuer to generate sufficient earnings to repay the debt obligation. So, for example, if a manufacturer of farm equipment issues a bond in which the bondholders have a first mortgage lien on one of its plants, the ability of the manufacturer to generate cash flow from all of its operations is required to pay off the bondholders.

In contrast, in an asset securitization transaction, the burden of the source of repayment shifts from the cash flow of the issuer to the cash flow of a pool of financial assets and/or a third-party that guarantees the pay-

² Recall from our discussion in Chapter 3 the use of special-purpose entities in off-balance-sheet financing.

ments if the pool of financial assets does not generate sufficient cash flow. For example, if the manufacturer of farm equipment has receivables from installment sales contracts to customers (i.e., a financial asset for the farm equipment company) and uses these receivables in a structured financing as described below, payment to the buyers of the bonds backed by these receivables depends only on the ability to collect the receivables. That is, it does not depend on the ability of the manufacturer of the farm equipment to generate cash flow from operations.

The process of creating securities backed by a pool of financial assets is referred to as *asset securitization*. The financial assets included in the collateral for an asset securitization are referred to as *securitized assets*.

Illustration of an Asset Securitization Transaction

Let's use an illustration to describe an asset securitization transaction. In our illustration, we will use a hypothetical firm, Farm Equip Corporation. This company is assumed to manufacture farm equipment. Some of its sales are for cash, but the bulk of its sales are from installment sales contracts. Effectively, an installment sale contract is a loan to the buyer of the farm equipment who agrees to repay Farm Equip Corporation over a specified period of time. For simplicity, we will assume that the loans are typically for four years. The collateral for the loan is the farm equipment purchased by the borrower. The loan specifies an interest rate that the buyer pays.

The credit department of Farm Equip Corporation makes the decision as to whether to extend credit to a customer. That is, the credit department will receive a credit application from a customer and, based on criteria established by the firm, will decide on whether to extend a loan and the amount. The criteria for extending credit or a loan are referred to as *underwriting standards*. Because Farm Equip Corporation is extending the loan, it is referred to as the *originator* of the loan.

Moreover, Farm Equip Corporation may have a department that is responsible for servicing the loan. *Servicing* involves collecting payments from borrowers, notifying borrowers who may be delinquent, and, when necessary, recovering and disposing of the collateral (i.e., farm equipment in our illustration) if the borrower does not make loan repayments by a specified time. While the servicer of the loans need not be the originator of the loans, in our illustration we are assuming that Farm Equip Corporation is the servicer.

Now let's get to how these loans can be used in a securitization transaction. We will assume that Farm Equip Corporation has more than \$200 million of installment sales contracts. This amount is shown on the corporation's balance sheet as an asset. We will further assume that Farm Equip Corporation wants to raise \$200 million. Rather than issuing corporate bonds for

\$200 million (for the reasons explained in the next section), the CFO decides to raise the funds via a securitization.

To do so, the Farm Equip Corporation will set up a legal entity referred to as a *special-purpose entity (SPE)*, also referred to as a *special-purpose vehicle (SPV)*. At this point, we will not explain the purpose of this legal entity, but it will be made clearer later that the SPE is critical in a securitization transaction. In our illustration, the SPE that is set up is called FE Asset Trust (FEAT). Farm Equip Corporation will then sell to FEAT \$200 million of the loans. Farm Equip Corporation will receive from FEAT \$200 million in cash, the amount it wanted to raise. But where does FEAT get \$200 million? It obtains those funds by selling securities that are backed by the \$200 million of loans. The securities are called *asset-backed securities*. The asset-backed securities issued in a transaction securitization are also referred to as bond classes or *tranches*. The structure is diagrammed in Figure 5.1.

A simple transaction can involve the sale of just one bond class with a par value of \$200 million. We will call this Bond Class A. Suppose that 200,000 certificates are issued for Bond Class A with a par value of \$1,000 per certificate. Then, each certificate holder would be entitled to 1/200,000 of the payment from the collateral. Each payment made by the borrowers (i.e., the buyers of the farm equipment) consists of principal repayment and interest.

A securitization transaction is typically more complicated. For example, there can be rules for distribution of principal and interest other than on a pro rata basis to different bond classes. It may be difficult to understand why such a structure should be created. What is important to understand is that there are institutional investors who have needs for bonds with different maturities and price volatility characteristics. A securitization transac-

FIGURE 5.1 Structured Financing

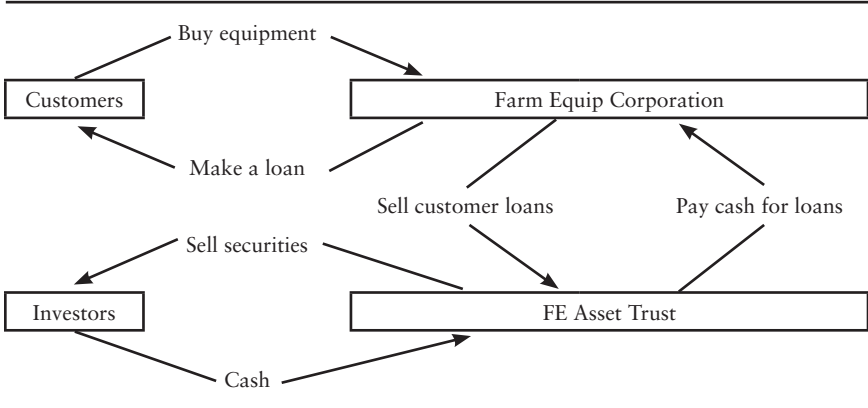

tion can be designed to create bond classes with investment characteristics that are more attractive to institutional investors to satisfy those needs.

An example of a more complicated transaction is one in which two bond classes are created, Bond Class A1 and Bond Class A2. The par value for Bond Class A1 is \$90 million and for Bond Class A2 is \$110 million. The priority rule can simply specify that Bond Class A1 receives all the principal that is paid by the borrowers (i.e., the buyers of the farm equipment) until all of Bond Class A1 has paid off its \$90 million and then Bond Class A2 begins to receive principal. Bond Class A1 is then a shorter-term bond than Bond Class A2.

As will be explained later, there are typically structures where there is more than one bond class but the two bond classes differ as to how they will share any losses resulting from defaults of the borrowers in the underlying collateral pool. In such a structure, the bond classes are classified as *senior bond classes* and *subordinate bond classes* and the structure is referred to as a *senior-subordinate structure*. Losses are realized by the subordinate bond classes before there are any losses realized by the senior bond classes. For example, suppose that FEAT issued \$180 million par value of Bond Class A, the senior bond class, and \$20 million par value of Bond Class B, the subordinate bond class. As long as there are no defaults by the borrower greater than \$20 million, then Bond Class A will be repaid fully its \$180 million.

Reasons for Using a Securitization Transaction

There are four principal reasons why a corporation may elect to issue an asset-backed security rather than a corporate bond. They are:

1. The potential for reducing funding costs.
2. To diversify funding sources.
3. To accelerate earnings for financial reporting purposes.
4. For regulated entities, potential relief from capital requirements.

We will focus on the first three reasons here.

Potential for Reducing Funding Costs

To understand the potential for reducing funding costs by issuing an asset-backed security rather than a corporate bond, suppose that in our illustration Farm Equip Corporation has a triple B credit rating. If it wants to raise funds equal to \$200 million and it issues a corporate bond, its funding cost would be whatever the benchmark Treasury yield is plus a yield spread for triple B issuers. Suppose, instead, that Farm Equip Corporation uses \$200 million

of its installment sales contracts (i.e., the loans it has made to customers) as collateral for a bond issue. What will be its funding cost? It probably will be the same as if it issued a corporate bond. The reason is that if Farm Equip Corporation defaults on any of its outstanding debt, the creditors will go after all of the corporate assets, including the loans to its customers.

However, suppose that Farm Equip Corporation can create another legal entity and sell the loans to that entity. That entity is the special-purpose vehicle that we described earlier in our hypothetical transaction. In our illustration, it is Farm Equipment Asset Trust (FEAT). If the sale of the loans by Farm Equip Corporation to FEAT is done properly—that is, the sale of the loans is at the fair market value—FEAT then *legally* owns the receivables, not Farm Equip Corporation. This means that if Farm Equip Corporation is forced into bankruptcy, its creditors *cannot* try to recover the loans (sold to FEAT) because they are legally owned by FEAT. What is the implication of structuring a transaction in this way?

When FEAT sells bonds backed by the loans (i.e., the asset-backed securities), those interested in buying the bonds will evaluate the credit risk associated with collecting the payments due on the loans independent of the credit rating of Farm Equip Corporation. What credit rating will be received for the bonds issued by FEAT? Whatever FEAT wants the credit rating to be! It may seem strange that the issuer (the SPE, FEAT) can get any credit rating it wants, but that is the case. The reason is that FEAT will show the characteristics of the collateral for the asset-backed securities (i.e., the loans to Farm Equip's customers) to a credit rating agency. In turn, the rating agency will evaluate the credit quality of the collateral and inform the issuer what must be done to obtain a desired credit rating.

More specifically, the issuer will be asked to “credit enhance” the structure. There are various forms of credit enhancement that we will review later. Basically, the rating agencies will look at the potential losses from the collateral and make a determination of how much credit enhancement is needed for the bond classes issued to achieve the targeted rating sought by the issuer. The higher the credit rating sought by the issuer, the more credit enhancement a rating agency will require for given collateral. Thus, Farm Equip Corporation, which we assumed is triple B rated, can obtain funding using the loans to its customers as collateral to obtain a better credit rating for the bonds issued than its own credit rating. In fact, with enough credit enhancement, it can issue a bond of the highest credit rating, triple A.

The key to a corporation issuing bonds with a higher credit rating than the corporation's own credit rating is the SPE. Its role is critical because it is the SPE (FEAT in our illustration) that legally separates the assets used as collateral from the corporation that is seeking financing (Farm Equip Corporation in our illustration).

Why wouldn't a CFO always seek the highest credit rating (triple A) for the bonds backed by the collateral in a securitization transaction? The answer is that credit enhancement does not come without a cost. As described later, there are various credit enhancement mechanisms and they increase the costs associated with borrowing via the issuance of asset-backed securities. So, the CFO must assess the trade-off when it is seeking a higher rating between the additional cost of credit enhancing the bonds versus the reduction in funding cost by issuing a bond with a higher credit rating.

It is important to realize that if a bankruptcy of the corporation seeking funds occurs (Farm Equip Corporation in our illustration), a bankruptcy judge may decide that the assets of the SPE are assets that the creditors of the corporation seeking financing may go after. This is an unresolved legal issue in the United States. Legal experts have argued that this is unlikely. In the prospectus of an asset-backed security, there will be a legal opinion addressing this issue. This is the reason why special-purpose vehicles in the United States are referred to as "bankruptcy remote" entities.

Diversifying Funding Sources

An issuer seeking to raise funds via securitization must establish itself as an issuer in the asset-backed securities market. Once that is done, it can look at both the corporate bond market and the asset-backed securities market to determine the better funding source. That is, it will compare the all-in-cost of funds in the corporate bond market and the asset-backed securities market and select the one with the lower cost.

Accelerating Earnings for Financial Reporting Purposes

A company has a choice in the accounting for asset securitization and the related accounts over the life of the asset servicing: the amortization method or the fair value method.³ In both cases, the servicing rights are accounted

³ Financial Accounting Series, *Statement of Financial Accounting Standards No. 156, Accounting for Servicing Financial Assets*, an amendment to FASB *Statement No. 140*, March 2006, amends *Statement of Financial Accounting Standards No. 140, Accounting for Transfers and Servicing of Financial Assets and Extinguishment of Liabilities*, with respect to the accounting for the securitization of assets. With SFAS 140, an originator who used derivatives to hedge risks associated with the securitization would face one method of accounting for the securitized assets, and another method for the related derivatives, resulting in asymmetrical accounting for two related transactions. SFAS 156 provides for symmetrical accounting for these related transactions. SFAS 156 is part of the evolving U.S. accounting principles that is addressing the use of fair value for financial assets and financial liabilities.

TABLE 5.1 Accounting Methods for Asset Securitization and Related Accounts Over Life of the Asset Servicing: Amortization and Fair Value Method

| Issue | Amortization Method | Fair Value Method |
|--|---|---|
| Recognition of income | <ul style="list-style-type: none"> ■ Amortize servicing rights over the period of the net servicing income. ■ Recognize periodic service fee income. | <ul style="list-style-type: none"> ■ Servicing fee income is recognized in earnings as earned. ■ Fair value adjustments of the interest-only strips are recognized as part of comprehensive income.^a |
| Value of servicing rights on the balance sheet | <ul style="list-style-type: none"> ■ Original fair value, less accumulated amortization and any valuation allowances or write-downs. | <ul style="list-style-type: none"> ■ Fair value (current). |
| Impairment | <ul style="list-style-type: none"> ■ Use valuation allowance for servicing assets. ■ Change in valuation allowance is recognized in earnings only if the fair value is less than the carrying amount. | <ul style="list-style-type: none"> ■ Recognized as a change in the fair value. |

^a The interest-only strip is an available-for-sale security and is adjusted to fair value each period. Any fair value adjustments are recognized as comprehensive income.

for using fair values when the assets are first securitized. After the initial transaction, the methods differ as shown in Table 5.1.

Generally accepted accounting principles permit a corporation to use a portfolio of its receivables or assets to accelerate earnings for shareholder reporting. This reason is best described by means of an illustration.

Consider again Farm Equip Corporation, the manufacturer of farm equipment. Suppose that this firm has \$200 million in installment sales contracts. For financial reporting purposes, the installment sales contracts are not recognized as revenue until the installment payments are received. Suppose that the agreement with the buyer of the farm equipment requires that the buyer pay 8% interest per annum. Suppose further that the CFO of Farm Equip Corporation approaches the firm's investment banker and is told that it can sell asset-backed securities backed by the installment sales contracts at a cost of 5%. This means that Farm Equip Corporation is receiving from the installment sales contracts 8% and would pay investors in the asset-backed securities 5%. The difference between what Farm Equip Corporation is receiving and paying is 3% or 300 basis points. Part of that difference represents a cost to Farm Equip Corporation for "servicing" the installment sales contracts. For now, assume that the servicing fee is 1%.

Reducing the 300 basis points by the 100 basis point servicing fee means that there are 200 basis points remaining. This is referred to as the *net interest spread* or *excess spread*. This spread is a profit to Farm Equip Corporation that will be realized by the sale of the asset-backed securities and it can be booked as income immediately. The income is effectively in the form of an asset referred to as *interest-only strip*. How much is the income that will be realized by Farm Equip Corporation for financial reporting purposes? Or equivalently, what is the value of the interest-only strip? We can apply the basic principle of valuation to determine it. This is done as follows. First, Farm Equip Corporation's finance staff must determine the dollar amount of the 200 basis points for each year over the expected life of the asset-backed securities. Then the present value of this dollar amount for each period is computed.

For example, suppose that the \$200 million in installment sales contracts call for a repayment of principal of \$50 million per year for the next four years. Then assuming that none of the borrowers default on their contractual obligation or pay off their loans earlier than the scheduled principal repayment date (referred to as a "prepayment"), this means that each year the dollar net interest based on the net interest spread of 200 basis points is as follows:

| Beg. of Year | Balance Outstanding | Dollar Net Interest |
|--------------|---------------------|---------------------|
| 1 | \$200,000,000 | \$4,000,000 |
| 2 | 150,000,000 | 3,000,000 |
| 3 | 100,000,000 | 2,000,000 |
| 4 | 50,000,000 | 1,000,000 |

The next step is to compute the present value of the dollar net interest. The question is: What is the appropriate discount rate? The discount rate should reflect the uncertainty of realizing the projected dollar net interest over the next four years. Let's suppose that a fair market rate is 12%. Then the present value of the dollar net interest discounted at 12% to the date the asset-backed securities are sold to the SPE, Year 0, 12% is \$8,022,088.78 as shown below:⁴

| End of Year | Dollar Net Interest to Be Received at the End of the Year | Present Value (\$) at the End of Year 0 |
|------------------------------|---|---|
| 1 | \$4,000,000 | \$3,571,428.57 |
| 2 | 3,000,000 | 2,391,581.63 |
| 3 | 2,000,000 | 1,423,560.50 |
| 4 | 1,000,000 | 635,518.08 |
| Value of interest-only strip | | \$8,022,088.78 |

⁴ Notice that calculations have been simplified by assuming that all of the dollar net interest spread is received at the end of the year.

The \$8,022,088.78 is the fair value of the interest-only strip at the time the asset-backed securities are issued. The value of the servicing of these assets is determined similarly, as the present value of the 100 basis points through the life of the installment payments, which in this example is \$4,011,044.39—half of that of the interest-only strip.

Calculating the amount of any gain or loss on the sale of the assets to the SPE and the carrying value of the servicing and interest-only strips depends on the fair value of the loans sold, the servicing asset, and the interest-only strip. The calculations require allocating the carrying value of the assets—\$200 million in our example—based on the relative fair market values of the three assets:

| | Fair Value in Millions | | % of Fair Value Total | | Carrying Amount in Millions |
|-------------------------|------------------------------|---------------------------------|-----------------------------|---------------------------|-----------------------------------|
| Loans sold ^a | \$204.011 | $\frac{\$204.011}{\$212.033} =$ | 96.217% | $96.217\% \times \$200 =$ | \$192.434 |
| Interest-only strip | <u>8.022</u> | $\frac{\$8.022}{\$212.033} =$ | <u>3.783%</u> | $3.783\% \times \$200 =$ | <u>7.566</u> |
| Total | \$212.033 | | 100.000% | | \$200.000 |

^a The fair value of the servicing asset is included in the fair value of the loan proceeds for this calculation. This represents a difference between pre-SFAS 156 and SFAS 156 accounting.

The gain on the sale is the difference between the proceeds, the \$204.011 million in this case, and the carrying amount of the loans sold:

| | In Millions |
|-------------------------------------|-----------------|
| Net proceeds | \$204.011 |
| Less: Carrying amount of loans sold | <u>192.434</u> |
| Gain on sale | <u>\$11.577</u> |

The key in the valuation of the interest-only strip is determining the dollar net interest spread each year and the appropriate interest rate at which to discount the dollar amount for each year. Consider first the dollar net interest each year. In the analysis above, it is assumed that the \$200 million in installment sales contracts will be paid—that is, no defaults are assumed. Suppose instead that, due to defaults, the CFO or his staff projects that the balance outstanding after defaults is as follows:

| Beg. of Year | Balance Outstanding | Dollar Net Interest |
|--------------|---------------------|---------------------|
| 1 | \$199,000,000 | \$3,980,000 |
| 2 | 147,000,000 | 2,940,000 |
| 3 | 95,000,000 | 1,900,000 |
| 4 | 42,000,000 | 840,000 |

Then the dollar net interest and the present value at 12% each year are shown below, along with the value of the interest-only strip:

| Beg. of Year | Dollar Net Interest to Be Received at the End of the Year | Present Value (\$) |
|------------------------------|---|--------------------|
| 1 | \$3,980,000 | \$3,553,571.43 |
| 2 | 2,940,000 | 2,343,750.00 |
| 3 | 1,900,000 | 1,352,382.47 |
| 4 | 840,000 | 533,835.19 |
| Value of interest-only strip | | \$7,783,539.09 |

Thus, based on this, the reported income due to the securitization would be \$7,783,539.09 (the value of the interest-only strip) versus \$8,022,088.78, in the case where no defaults are assumed. If a more appropriate discount rate is higher than 12%, then the value of the interest-only strip is reduced. For example, at a 15% rate, the value of the interest-only strip is \$7,633,477.58 assuming no defaults, and \$7,413,485.51 assuming the defaults in the table above.

If there are prepayments, this reduces the value of the interest-only strip. This is because when a borrower repays a loan, this reduces the loan balance. The issuer receives the dollar net interest only on the outstanding loan balance. For example, suppose that there are no defaults but that the borrowers prepay their loans such that the balance outstanding each year is as follows:

| Year | Balance Outstanding (Beginning of Year) | Dollar Net Interest (End of Year) |
|------|---|-----------------------------------|
| 1 | \$200,000,000 | \$4,000,000 |
| 2 | 70,000,000 | 1,400,000 |
| 3 | 20,000,000 | 400,000 |
| 4 | 10,000,000 | 200,000 |

It can be shown that the present value of the interest-only strip in this case is \$5,099,315.71. When discounted at a 12% rate, the value is less than even the case above where there are defaults.⁵

It is not a simple task to determine the defaults and therefore the dollar net interest and the appropriate interest rate for discounting. Consequently, the firm's external auditors must assess the assumptions made by management in determining income resulting from a securitization. There are shareholder suits against management and its external auditors in cases where shareholders have challenged income generated from a securitization for a firm that has faced financial difficulties. The issue is whether reasonable assumptions were made regarding defaults and whether the appropriate discount rate was used.

It is important to understand that securitization affects reported financial results. The company reports the following:

- A gain or loss on the sale of the assets to the SPE.
- A servicing asset (or liability in the case of inadequate compensation for services).
- The interest-only strip as an available-for-sale security.
- Adjustments to fair value each period that affect comprehensive income and, hence, reported shareholders equity.
- Servicing income on the income statement.

The CFO should be aware of the income statement and balance sheet implications of the securitization.

One more advantage should be noted. Our discussion here deals with realization of income for financial reporting purposes. How about the tax treatment? Under the tax code, the sale of the assets to the SPE and the resulting income need not be recognized for this purpose. That is, income realized for financial reporting purposes need not be realized for tax purposes. So, income can be accelerated for financial reporting purposes by selling financial assets on the balance sheet via a securitization but taxes on that income can be postponed for tax purposes.

What Rating Agencies Look at in Rating Asset-Backed Securities

In analyzing credit risk for asset-backed securities, the rating agencies (Moody's Investors Service, Standard & Poor's, and Fitch) focus on (1)

⁵ The value of the interest-only strip affects the gain or loss on the sale, the initial carrying value of the interest-only strip receivable, and the periodic adjustments to fair value.

credit quality of the collateral, (2) the quality of the seller/servicer, and (3) cash flow stress and payment structure. We discuss each below.

Credit Quality of the Collateral Analysis of the credit quality of the collateral depends on the asset type. The rating agencies will look at the underlying borrower's ability to pay and the borrower's equity in the asset. By the "borrower" we mean the individual or business entity that took out the loan. In our Farm Equipment Corporation illustration, the borrowers are the entities that purchased the farm equipment via an installment sales contract. The borrower's equity will be a key determinant as to whether a borrower has an economic incentive to default or to sell the asset and pay off a loan.

The rating agencies will also look at the experience of the originators of the underlying loans and will assess whether the loans underlying a specific transaction have the same characteristics as the experience reported by the issuer. That is, the originator of the loan or installment sales contract—Farm Equip Corporation in our illustration—will have a credit department that will assess whether to extend credit to a customer. If the underwriting standards are lax, then this will be reflected in high default rates; tough underwriting standards will be reflected in low default rates. Rating agencies will assess the underwriting standards by looking at historical default rates of an originator and will monitor the default rates over time to determine if there has been a deterioration or an improvement in underwriting standards. In addition to default rates, rating agencies will look at historical recovery rates. It is the default rates combined with recovery rates that determine what the potential loss will be.

The concentration of loans is examined by rating agencies. The underlying principle of asset securitization is that the large number of borrowers in the collateral pool will reduce the credit risk via diversification. If there are a few borrowers included in the collateral pool that are significant in size relative to the entire pool balance, this diversification benefit can be lost, resulting in a higher level of default risk. This risk is called *concentration risk*. Rating agencies will set concentration limits on the amount or percentage of loans or receivables from any one borrower. If the concentration limit at issuance is exceeded, the asset-backed securities will receive a lower credit rating than if the concentration limit was not exceeded. If after issuance the concentration limit is exceeded, one or more of the asset-backed securities in the structure may be downgraded.

Quality of the Seller/Servicer All loans and receivables must be serviced. These responsibilities are fulfilled by a third party to a securitization transaction called a *servicer*. While viewed as a "third-party," in many transactions, the

servicer is effectively the originator of the loans used as the collateral for the corporation seeking funding.

The servicer may also be responsible for advancing payments when there are delinquencies in payments (that are likely to be collected in the future) resulting in a temporary shortfall in the payments that must be made to the investors in the securities issued in the transaction.

The role of the servicer is critical in a securitization transaction. Therefore, rating agencies look at the ability of a servicer to perform all the activities that a servicer will be responsible for before they assign a credit rating to the bonds issued. For example, the following factors are reviewed when evaluating servicers: servicing history, experience, servicing capabilities, human resources, financial condition, and growth/competition/business environment.

Based on its analysis, a rating agency determines whether the servicer is acceptable or unacceptable. If a servicer is unacceptable, a securitization transaction will not be rated. The rating agency may require a “backup” servicer if there is a concern about the ability of a servicer to perform.

Cash Flow Stress and Payment Structure The rating agencies will analyze the extent to which the cash flow from the collateral can satisfy all of the obligations of the securities issued in the transaction. Though each agency’s analysis, referred to as a *cash flow stress test*, is different, they share common attributes: They test whether the collateral’s cash flows match the required payments to satisfy the issuer’s obligations under different scenarios. The cash flow of the collateral consists of interest and principal repayment. The cash flow payments that must be made are interest and principal to investors, servicing fees, and any other expenses for which the issuer is liable. This requires that the rating company make assumptions about losses and delinquencies under various interest rate scenarios.

Based on its analysis of the collateral and the stress testing of the structure to assess the risk that the investors in the asset-backed securities will not be repaid in full, a rating agency will determine the amount of credit enhancement necessary for an issue to receive a particular credit rating.

Credit Enhancement

The way credit enhancement works is some third party is either paid a fee (or an insurance premium) or earns extra yield on a security in the structure to assume credit risk. There are two forms of credit enhancement—external and internal. *External credit enhancement* involves third-party guarantees such as insurance or a letter of credit. *Internal credit enhancement* includes overcollateralization, senior-subordinated structure, and reserves. Deals will

often have more than one form of credit enhancement. The rating agencies specify the amount of credit enhancement to obtain a specific credit rating. The issuer decides on what mechanisms to use.

It is critical for the issuer to examine each form of credit enhancement prior to issuance to determine the enhancement mechanism or combination of credit enhancement mechanisms that is most cost effective. Over time, due to changing market conditions, the least expensive form of credit enhancement today may not be the least expensive in a subsequent securitization transaction.

As explained earlier, the reason why an issuer does not simply seek a triple A rating for all the securities in the structure is that there is a cost to doing so. The issuer must examine the cost of credit enhancing a structure to obtain a triple A rating versus the reduction in the yield (i.e., the increase in price) at which it can offer the securities due to a triple A rating. In general, in deciding to improve the credit rating on some securities in a structure, the issuer will evaluate the trade-off associated with the cost of enhancement versus the reduction in yield required to sell the security.

Below we describe the various forms of credit enhancement mechanisms.

Third-Party Guarantees

Perhaps the easiest form of credit enhancement to understand is insurance or a letter of credit. In this form of credit enhancement, an insurance provider agrees, for a fee, to guarantee the performance of a certain amount of the collateral against defaults. If, for example, a loan in the collateral pool goes into default and the underlying collateral is repossessed and then sold at a loss resulting in a partial payoff of the outstanding loan balance, the bondholders would be in a position not to recover the principal outstanding for that loan. To provide protection to the bondholders, an insurance provider will pay the difference between the loan payoff amount and the amount due to the bondholders, thereby absorbing the loss.

The rating agencies decide on the creditworthiness of the insurance provider to determine the credit rating of the bonds. Perhaps the biggest perceived disadvantage to this form of credit enhancement is so-called *event risk*. Triple A rated bondholders, for example, can enjoy triple A status only as long as the enhancement provider retains its triple A credit rating status. If the credit enhancement provider is downgraded (i.e., its credit rating is lowered by a rating agency), the bonds guaranteed by the enhancement provider are typically downgraded as well.

Overcollateralization

One form of internal credit enhancement is *overcollateralization*. In this form of credit protection, credit enhancement is provided by issuing bonds with a par value that is less than the par value of the loans or receivables in the collateral pool. For example, if there are \$200 million of loans in a collateral pool and the issuer wanted to use overcollateralization for credit enhancement to achieve, say, a triple A credit rating for the bonds to be issued, the issuer would obtain from the rating agencies an indication as to how many bonds it could issue versus the \$200 million par value of loans in the collateral pool to obtain the target credit rating. Depending on the characteristics of the loans and their perceived creditworthiness, the rating agencies might allow \$190 million of par value of bonds to be issued.

This means that cash flows for \$200 million par value of loans are available to bondholders but only \$190 million par value of bonds need to be paid interest and principal. The cash flows from the extra \$10 million of loans can either flow into a “reserve account” where the flows are reserved until such a time as they are needed to cover losses or the funds are used to retire bonds early. If a \$3 million loss is realized by the collateral pool, there will still be enough cash flow from the other loans to ensure that the triple A rated bonds receive their payments. After all the bonds have been retired, the remaining funds in the reserve account and any remaining collateral are distributed to the originator (assuming the originator has not sold its interest in the collateral).

The cost of such an arrangement is implicit in the price paid for \$200 million par value of collateral versus the proceeds of issuing only \$190 million par value of bonds.

Senior-Subordinate Structure

Another form of internal credit enhancement is the senior-subordinate structure mentioned earlier. This involves the subordination of some bond classes for the benefit of attaining a high investment-grade rating for other bond classes in the structure. Based on an analysis of the collateral, a rating agency will decide how many triple A bonds can be issued, how many double A bonds, and so forth down to nonrated bonds. A structure can have simply two bond classes, a senior bond class and a subordinate bond class. Or it can have several subordinate bond classes in addition to the senior bond class.

For example, suppose that a senior-subordinate structure for \$200 million of collateral for the Farm Equip Corporation is as follows:

| Bond Class | Rating | Percent of Structure | Par Value |
|------------|-----------|----------------------|---------------|
| A | AAA | 65% | \$130 million |
| B | AA | 20 | 40 million |
| C | BBB | 10 | 20 million |
| D | Not rated | 5 | 10 million |

Bond class A is the senior bond class. The subordinate bond classes are B, C, and D.

The rule for recognizing losses is as follows. As a \$1 of loss on the collateral is realized, that loss is first applied to bond class D. When bond class D has no balance, the next dollar of loss is applied to bond class C, and then bond class B. After all the subordinate bond classes are wiped out due to losses, the losses are realized by the senior bond class.

The cost of this form of credit enhancement is based on the proceeds for selling the bonds, which is in turn determined by the demand for the bonds. The yields that must be offered on the bond classes are affected by the yields demanded by investors. The lower the credit rating of the bond class (i.e., the more likely the bond class is to realize a loss), the more yield is demanded and the lower will be the proceeds received from the sale of the bonds for that bond class. The proceeds for the sale of all the bonds have to be compared to the cost of the collateral pool.

One of the perceived advantages of internal credit enhancements such as the overcollateralization and the senior-subordinate structure is the lack of event risk that accompanies external credit enhancement (i.e., a third-party guarantee). The assets in the collateral pool provide all credit support and investors are at risk only with regard to the performance of those assets.

Reserve Funds

Reserve funds come in two forms, cash reserve funds and excess spread. Cash reserve funds are straight deposits of cash generated from issuance proceeds. In this case, part of the underwriting profits from the deal are deposited into a fund and used to offset any losses. Excess spread accounts involve the allocation of excess spread into a separate reserve account after paying out the coupon to bondholders, the servicing fee, and all other expenses on a monthly basis.

STRUCTURED NOTES

For a plain-vanilla bond structure, (1) the coupon interest rate is either fixed over the life of the security or floating at a fixed spread to a reference rate;

and (2) the principal is a fixed amount that is due on a specified date. There are bonds that have slight variations that are common in the marketplace. A callable bond may have a redemption date that is prior to the scheduled maturity date. The option to call the bond prior to the maturity date resides with the issuer; the benefit of calling the issue depends on the market interest rate at which the callable bond issue can be refinanced. Similarly, a puttable bond has a maturity date that can be shortened, but in this case the option resides with the bondholder; if the market rate on comparable bonds exceeds the coupon rate, the bondholder will exercise. A convertible bond typically has at least two embedded options. The first is the bondholder's right to convert the bond into common stock. The second is the issuer's right to call the bond. Some convertible bonds are also puttable.

Callable, puttable, and convertible bonds are considered traditional securities, as are other similar structures such as extendible and retractable bonds.⁶ There are bonds with embedded options that have much more complicated provisions for one or more of the following: interest rate payable, redemption amount, and timing of principal repayment. The interest or redemption amount can be tied to the performance or the level of one or more interest rates or noninterest rate benchmarks. As a result, the potential performance (return and risk) of such securities will be substantially different from those offered by plain-vanilla bond structures. These securities are popularly referred to as *structured notes*.

In a survey article on structured notes, Telpner defines structured notes as "fixed-income securities—sometimes referred to as hybrid securities that present the appearance of fixed-income securities—that combine derivative elements and do not necessarily reflect the risk of the issuer."⁷ Here the key element is that the issuer is not necessarily taking on the opposite risk of the investors.

In their book on the structured notes market, Peng and Dattatreya write, "Structured notes are fixed income debentures linked to derivatives."⁸ They go on to say:

A key feature of structured notes is that they are created by an underlying swap transaction. The issuer rarely retains any of the risks embedded in the structured note and is almost hedged out of

⁶ An extendible bond grants the issuer the right to extend the redemption date beyond the stated maturity date. A retractable bond grants the bondholder the right to redeem on a date prior to the original maturity date.

⁷ Joel S. Telpner, "A Survey of Structured Notes," *The Journal of Structured and Project Finance* (Winter 2004), pp. 6–19.

⁸ Scott Y. Peng and Ravi Dattatreya, *The Structured Note Market* (Chicago: Probus Publishing, 1995).

TABLE 5.2 Maturity Profile Factor, Typical Form of Instrument, and Typical Issuer

| Maturity | Typical Form of Instrument | Typical Issuer |
|----------------------|--|--------------------------|
| Under 1 year | Commercial paper | A1/P1 rated corporations |
| 1 to 3 years | Commercial paper, bank note, medium-term notes | Banks, corporations |
| Greater than 3 years | Corporate bond, medium-term notes | U.S. government agencies |

Adapted from Scott Y. Peng and Ravi Dattatreya, *The Structured Note Market* (Chicago: Probus, 1995), p. 303.

the risks of the note by performing a swap transaction with a swap counterparty. This feature permits issuers to produce notes of almost any specification, as long as they are satisfied that the hedging swap will perform for the life of the structured note. To the investor, this swap transaction is totally transparent since the only credit risk to which the investor is exposed is that of the issuer.⁹

In this definition, the focus is not on the issuer selling a debt instrument with derivative-type payoffs to investors, but the issuer protecting itself against the risks associated with the potential payoffs it must make to investors by hedging those risks. That is, the upside potential available to investors in a structured note does not reflect risk to the issuer. While Peng and Dattatreya say that this can be done with a swap transaction, any other derivative can be employed to hedge the risk faced by an issuer.¹⁰

A structured note can be issued in the public market or as a private placement or a 144A security.¹¹ It can take the form of either commercial paper, a medium-term note, or a corporate bond. The issuer must be of high credit quality so that credit risk is minimal in order to accomplish the objectives that motivated the creation of the structured note. Issuers include highly rated corporations, banks, and U.S. government agencies. Because credit risk increases over time, the type of issuer and the form of the security are tied to the planned holding period of the investor. Table 5.2 provides a

⁹ Peng and Dattatreya, *The Structured Note Market*, p. 2.

¹⁰ A *swap* is a transaction that results in the exchange of a stream of cash flows among parties. For example, a swap may involve two parties: one that has a fixed payment cash flow stream and another that has a floating (that is, variable) cash flow stream. These parties can agree to exchange these cash flow streams in a swap agreement. Swaps are described in Chapter 8.

¹¹ As explained in Chapter 3, a *144A security* is one that satisfies the requirements of Rule 144A of the Securities Act of 1933, which exempts securities sold to qualified institutional buyers from the registration requirements of the Act.

summary of the relationships among the maturity profile of the investor, the typical form of the debt instrument, and the typical issuer.

Motivation for Investors

The motivation for the purchase of structured notes by investors includes (1) the potential for enhancing yield; (2) acquiring a view on the bond market; (3) obtaining exposure to alternative asset classes; (4) acquiring exposure to a particular market but not a particular aspect of it;¹² and (5) controlling risks.

The potential for yield enhancement was the motivation behind the popularity of structured notes in the sustained low-interest-rate environment in the late 1980s. After the high interest rates (double digits) that prevailed in the early 1980s, institutional investors faced interest rates that were not sufficient to satisfy the liabilities for the financial products they created during the high-interest-rate environment. Local governments had come to rely on interest income from higher interest rates in order to fund operations and avoid raising property and personal taxes. Structured notes offered the potential to provide a higher return than that prevailing in the market for plain-vanilla debt obligations if certain market scenarios occurred.

The ability of issuers to hedge risk using derivatives allowed them to create securities for investors who had a view on the bond market. For example, a structured note could be created that allowed exposure to a change in the yield curve, the change in the spread between two reference interest rates, or the direction of interest rates (e.g., a leveraged payoff if interest rates declined).

Structured notes that have payoffs based on the performance of asset classes other than bonds allow investors to take views on other markets in which they may be prohibited from investing by regulatory or client constraint. For example, suppose that an investor who must restrict portfolio holdings to investment-grade bonds has a view on the equity market. The investor would not be permitted to invest in equities. However, by investing in an investment-grade bond whose payoff is based on the performance of the equity market, the investor has obtained exposure to the equity market. For this reason, some market participants refer to structured notes as “rule busters.”

Finally, a structured note can be used to hedge exposure that an investor may not be able to hedge more efficiently using derivative products. For example, suppose that an investor is concerned with exposure in its current portfolio to changes in credit spreads. While there are currently credit derivatives that would allow the investor to hedge this exposure, suppose

¹² For example, a U.S. investor may want exposure to Japanese equities but not yen assets, so the investor can buy U.S.-dollar-denominated bonds that have a payoff linked to the Japanese stock market index.

that the investor is not permitted to utilize them. An investor can have an issuer create a structured note that has a payoff based on a particular credit spread. The issuer can protect itself by taking a position in the credit derivatives market.

But what is the benefit of all this customization for the issuer? By creating a customized product for an investor, the issuer seeks a lower funding cost than if it had issued a bond with a plain-vanilla structure.

How do borrowers or their agents find investors who are willing to buy structured notes? In a typical plain-vanilla bond offering, the sales force of the underwriting firm solicits interest in the issue from its customer base. That is, the sales forces will make an inquiry to investors about their needs and preferences. In the structured note market, the process is often quite different. Because of the small size of an offering and the flexibility to customize the offering in the swap market, investors can approach an issuer through its agent about designing a security for their needs. This process of customers inquiring of issuers or their agents to design a security is called a *reverse inquiry*.

Creating Structured Notes

Peng and Dattatreya describe the three main steps in creating a structured note:¹³

1. Conceptual stage
2. Identification process
3. Structuring or construction stage

In customizing a structured note for a client, the investment banker must understand the client's motivation. This is the conceptual stage of the process. We described earlier why investors look to the structured note market for customization. The investor will provide the motivation through reverse inquiry. However, the design of the structure note should consider the possible tax impact on the investor. For example, in the United States, if the note provides protection of the principal, the profits to individual investors are generally treated as ordinary income; if the note does not provide any principal protection, profits on the note may be treated as capital gain income and given preferential treatment if the holding period is satisfied. The challenge is that while the two extremes are easy to figure out, the tax treatment is not clear in the case of notes with some protection of the principal.¹⁴

¹³ Chapter 8 in Peng and Dattatreya, *The Structured Note Market*.

¹⁴ Anne Tergesen, "Quirkiest Vehicle on the Street," *BusinessWeek*, November 20, 2006.

In the identification process, the investment banker identifies the underlying components that will be packaged to create the structured note based on the requirements identified in the conceptual stage. This process begins with specifying five customization factors: nationality, rate profile, risk/return, maturity, and credit. The nationality factor specifies the country where the client would like to have some investment exposure. In the case of structured notes where the underlying is an interest rate, the rate factor determines the directional play (e.g., rising or falling interest rates, flattening or steepening yield curve) that is to be embedded in the structure. The amount of risk to be embedded in the structured note is the risk/return customization factor. Both the maturity and credit customization factors determine the instrument that will be used and the type of issuer as described in Table 5.2.

In the structuring or construction stage, the investment banker gathers the pertinent market data and issuer-specific information. This information includes the target funding cost for the issuer (after underwriting fees) and the desired coupon and principal structure based on information from the conceptual and identification stages. In determining the cost of the structure, recognition must be given to the hedging cost that will be incurred when using the derivative instrument or instruments. Other specifications of the structured note that may have to be determined will depend on the complexity of the structure. For example, a structure may require that the correlation of the factors driving the price of the underlying instruments in the structure be estimated.

Two Examples of Structured Notes

A wide range of structured notes have been created in the market. Here we will discuss only two types: interest-rate structured notes (more specifically, an inverse floater) and an equity-linked structured note. While we do not describe the derivative instrument used in the creation of these two structured notes, swaps, until Chapter 8, the principles are fairly simple to follow.

Interest-Rate Linked Structured Notes

The general coupon formula for a floating-rate security (floater) is

$$\text{Reference rate} + \text{Quoted margin}$$

A structured note whose coupon rate is linked to a reference rate has a coupon reset formula that differs from the previous example. Typically, the coupon formula on floaters is such that the coupon rate increases when the

reference rate increases, and decreases when the reference rate decreases. There are structured notes whose coupon rate moves in the opposite direction from the change in the reference rate. Such issues are called *inverse floaters* or *reverse floaters*.

The coupon reset formula for an inverse floater is

$$\text{Coupon rate} = K - [L \times (\text{Reference rate})]$$

When L is greater than 1, the security is referred to as a *leveraged inverse floater*. For example, suppose that for a particular inverse floater K is 12% and L is 1. Then the coupon reset formula would be:

$$\text{Coupon rate} = 12\% - (\text{Reference rate})$$

Suppose the reference rate is the 1-month LIBOR; then the coupon formula would be:¹⁵

$$\text{Coupon rate} = 12\% - (1\text{-month LIBOR})$$

If in some month the 1-month LIBOR at the coupon reset date is 5%, the coupon rate for the period is 7%. If in the next month the 1-month LIBOR declines to 4.5%, the coupon rate increases to 7.5%.

Notice that if the 1-month LIBOR exceeds 12%, then the coupon reset formula produces a negative coupon rate. To prevent this, there is a floor imposed on the coupon rate. Typically, the floor is zero. There is also a cap on the inverse floater. This occurs if the 1-month LIBOR is zero. In that unlikely event, the maximum coupon rate is 12% for our hypothetical inverse floater. In general, it will be the value of K in the coupon reset formula for an inverse floater.

An inverse floater can be created when an investment banking firm underwrites a fixed-rate bond and simultaneously enters into an interest rate swap with the issuer where the maturity of the swap is generally less than the maturity of the structured note that will be issued. The investor owns an inverse floater for the swap's tenor (that is, the term of the swap agreement), which then converts to a fixed-rate bond (the underlying collateral) when the swap contract expires. An inverse floater created using a swap is called an *indexed inverse floater*.

To see how this can be accomplished, assume the following. The CFO wants to issue \$200 million on a fixed-rate basis for 20 years. An investment banker suggests two simultaneous transactions.

¹⁵ The London Interbank Offered Rate (LIBOR) is a widely used reference rate for many financial instruments.

Transaction 1: Issue a \$200 million, 20-year bond in which the coupon rate is determined by the following rules for a specific reference rate:

For years 1 through 5: Coupon rate = 14% – Reference rate
 For years 6 through 10: Coupon rate = 5%

Transaction 2: Enter into a 5-year interest rate swap with the investment bank with a notional principal amount of \$200 million in which semiannual payments are exchanged as follows using the same reference rate:

Issuer pays the reference rate
 Issuer receives 6%

Note that for the first five years, the investor owns an inverse floater because as the reference rate increases (decreases) the coupon rate decreases (increases). However, even though the security issued pays an inverse floating rate, the combination of the two transactions results in fixed-rate financing for the issuer:

Rate issuer receives

From the investment bank for its swap payment: 6%

Rate issuer pays

To security holders as interest: 14% – Reference rate

To the investment bank for its swap obligation: Reference rate

Net payments

$(14\% - \text{Reference rate}) + \text{Reference rate} - 6\% = 8\%$

Equity-Linked Structured Notes

An equity swap can be used to design a bond issue with a coupon rate tied to the performance of an equity index. Such a bond issue is referred to as an *equity-linked structured note*. Such notes may be designed many different ways, but the basic idea is to blend the features of a low or zero-coupon bond with potential for the investor to participate in the upward movement of an equity index.

To illustrate how this is done, suppose the Universal Information Technology Company (UIT) seeks to raise \$100 million for the next five years on a fixed-rate basis. UIT's investment banker indicates that if bonds with a maturity of five years were issued, the interest rate on the issue would have

to be 8.4%. At the same time, there are institutional investors who are seeking to purchase bonds but are interested in making a play on (i.e., betting on) the future performance of the stock market. These investors are willing to purchase a bond whose annual interest rate is based on the actual performance of the S&P 500 stock market index.

The banker recommends to UIT's CFO that it consider issuing a 5-year bond whose annual interest rate is based on the actual performance of the S&P 500. The risk with issuing such a bond is that UIT's annual interest cost is uncertain since it depends on the performance of the S&P 500. However, suppose that the following two transactions are arranged:

1. On January 1, UIT agrees to issue, using the banker as the underwriter, a \$100 million 5-year bond whose annual interest rate is the actual performance of the S&P 500 that year minus 300 basis points. The minimum interest rate, however, is set at zero. The annual interest payments are made on December 31.
2. UIT enters into a 5-year, \$100 million notional amount equity swap with the banker in which each year for the next five years UIT agrees to pay 7.9% to the banker, and the banker agrees to pay the actual performance of the S&P 500 that year minus 300 basis points. The terms of the swap call for the payments to be made on December 31 of each year. Thus, the swap payments coincide with the payments that must be made on the bond issue. Also as part of the swap agreement, if the S&P 500 minus 300 basis points (bp) results in a negative value, the banker pays nothing to UIT.¹⁶

Figure 5.2 diagrams the payment flows for this swap. Consider what has been accomplished with these two transactions from the perspective of UIT. Specifically, focus on the payments that must be made by UIT on the bond issue and the swap and the payments that it will receive from the swap. These are summarized as follows:

| | |
|----------------------------------|-------------------------|
| Interest payments on bond issue: | S&P 500 return – 300 bp |
| Swap payment from the banker: | S&P 500 return – 300 bp |
| Swap payment to the banker: | 7.9% |
| Net interest cost: | 7.9% |

¹⁶ The trading desk of the investment banking firm can hedge this risk with a basis swap that pays a fixed or floating cash flow in return for receiving the return on the S&P.

FIGURE 5.2 Bond Structure: Conventional versus S&P Linked Note
 Panel A. Conventional Bond Issue

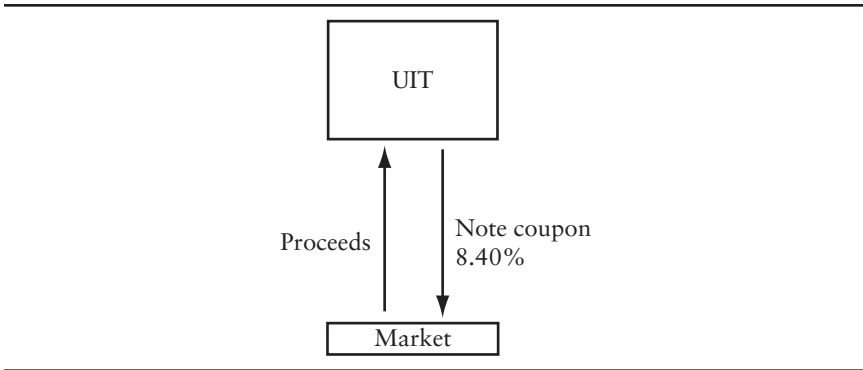

Panel B. S&P Linked Note

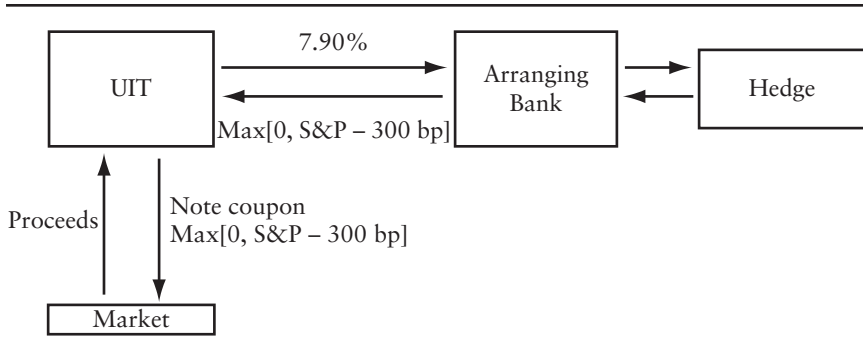

Thus, the net interest cost is a fixed rate despite the bond issue paying an interest rate tied to the S&P 500. This was accomplished with the equity swap.

There are several questions that should be addressed. First, what was the advantage to UIT to entering into this transaction? Recall that if UIT issued a bond, the banker estimated that UIT would have to pay 8.4% annually. Thus, UIT has saved 50 basis points (8.4% minus 7.9%) per year. Second, why would investors purchase this bond issue? In real-world markets, there are restrictions imposed on institutional investors as to the types of investment or by other portfolio guidelines. For example, an institutional investor may be prohibited by a client or by other portfolio guidelines from purchasing common stock. However, it may be permitted to purchase a bond of an issuer such as UIT despite the fact that the interest rate is tied to the performance of common stocks. Third, is the banker exposed to the risk

of the performance of the S&P 500? In the swap market, there are ways for the banker to protect itself.

BOTTOM LINE

- Asset securitization is the process of creating securities backed by a pool of financial assets.
- Asset securitization provides an alternative to the issuance of a corporate bond.
- The securities issued in a securitization transaction are backed by loans, accounts receivable, or notes receivable and are referred to as asset-backed securities.
- It is the collateral combined with any third-party guarantees that will determine the ability of an issuer to pay the obligation to the holders of the asset-backed securities. To obtain a desired credit rating sought by a corporation by using a securitization financing, both the cash flow of a financial asset and a third-party credit support may be needed.
- The four principal reasons why a corporation may elect to issue asset-backed securities rather than a corporate bond are (1) potential for lower funding cost, (2) diversification of funding sources, (3) acceleration of earnings for financial reporting purposes, and (4) potential for reducing capital requirements for regulated entities.
- The key to a corporation issuing asset-backed securities with a higher credit rating than the corporation's own credit rating via a securitization is the special-purpose vehicle. Its role is critical because it is the special-purpose vehicle that legally separates the assets used as collateral from the corporation that is seeking financing.
- When assigning a credit rating to an asset-backed security, the rating agencies analyze (1) the credit quality of the collateral, (2) the quality of the seller/servicer, and (3) the cash flow stress and payment structure.
- There are two forms of credit enhancement that can be used in a structured finance transaction. External credit enhancement involves third-party guarantees such as insurance or a letter of credit. Internal credit enhancement includes overcollateralization, senior-subordinated structures, and reserves.
- Structured notes are bonds with embedded options that have much more complicated provisions for interest rate payable, redemption amount, and /or timing of principal repayment that have the risk and return substantially different from those offered by plain vanilla bond structures.
- Typically derivative instruments are used in creating structured notes so that the issuer can hedge the risk associated with the issue.

- Investor motivation for purchasing structured notes includes the potential for enhancing yield, acquiring a view on the bond market, obtaining exposure to alternative asset classes, acquiring exposure to a particular market but not a particular aspect of it, and controlling risks.
- Corporations are willing to issue structured notes in order to reduce their all-in-cost of funds.
- The main steps in creating a structured note are the conceptual stage, the identification process, and the structuring or construction stage.

PART

Two

Strategy, Taxes, and Risk Management

Strategy and Financial Planning

AGENDA

- Item 1* Explain the role of the strategic plan in budgeting.
- Item 2* Identify the sources of value creation.
- Item 3* Describe what is meant by a comparative advantage and a competitive advantage of a company.
- Item 4* Explain the relationship between strategy and maximization of shareholder value.
- Item 5* Distinguish between operational budgeting and long-term financial planning.
- Item 6* Relate the different types of budgets to the budgeting process.
- Item 7* Explain the different tools that can be used for sales forecasting and budgeting.
- Item 8* Describe the role of financial modeling in financial planning.
- Item 9* Relate the performance measurements of economic value added and the balanced scorecard to the strategic planning process.
- Item 10* Identify sources of value creation and relate these sources to Porter's Five Forces.
- Item 11* Explain the role of the CFO in a company's strategic plan.

A business that is able to deploy its assets to the best possible use creates value and advances the efficient allocation of resources for society as a whole. Owners, employees, customers, and anyone else who has a stake in the business enterprise are all better off when its management makes decisions that puts its assets to their best use. But just as there may be alternative routes to a destination, there may be alternative ways to allocate resources. A *strategy* is a plan of action of how to reach an objective. And just as some routes may get you where you are going faster, some strategies may be better than others.

Suppose a company has decided it has an advantage over its competitors in marketing and distributing its products in the global market. The

company's strategy may be to expand into the European market, followed by an expansion into the Asian market. Once the company has its strategy, it needs a plan, in particular the *strategic plan*, which is the set of actions the company intends to use to follow its strategy.

The investment opportunities that enable the company to follow its strategy comprise the company's *investment strategy*. The company may pursue its strategy of expanding into European and Asian markets by either establishing itself or acquiring businesses already in these markets. This is where capital budgeting analysis comes in: The CFO evaluates the possible investment opportunities to see which ones, if any, provide a return greater than necessary for the investment's risk. And let's not forget the investment in working capital, the resources the company needs to support its day-to-day operations.

Suppose as a result of evaluating whether to establish or acquire businesses, our company decides it is better—in terms of maximizing the value of the company—to acquire selected European businesses. The next step is to figure out how it is going to pay for these acquisitions. The CFO must make sure that the company has sufficient funds to meet its operating needs, as well as its investment needs. This is where the company's financing strategy enters the picture. Where should the needed funds come from? What is the precise timing of the needs for funds? To answer these questions, working capital management (in particular, short-term financing) and the capital structure decision (the mix of long-term sources of financing) enter the picture.

When the CFO looks at the company's investment decisions and considers how to finance them, he or she is budgeting. *Budgeting* is mapping out the sources and uses of funds for future periods. Budgeting requires both economic analysis (including forecasting) and accounting. Economic analysis includes both marketing and production analysis to develop forecasts of future sales and costs. Accounting techniques are used as a measurement device: But instead of using accounting to summarize what has happened (its common use), in budgeting, companies use accounting to represent what the CFO expects to happen in the future. The process is summarized in Figure 6.1.

Once these plans are put into effect, the CFO must compare what happens with what was planned. This is referred to as *post-auditing*, which companies use to:

- Evaluate the performance of management.
- Analyze any deviations of actual results from planned results.
- Evaluate the planning process to determine just how good it is.

The purpose of this chapter is to explain strategic planning and how financial planning and budgeting are used in this process. In Chapter 25, we

FIGURE 6.1 Strategy and Budgeting

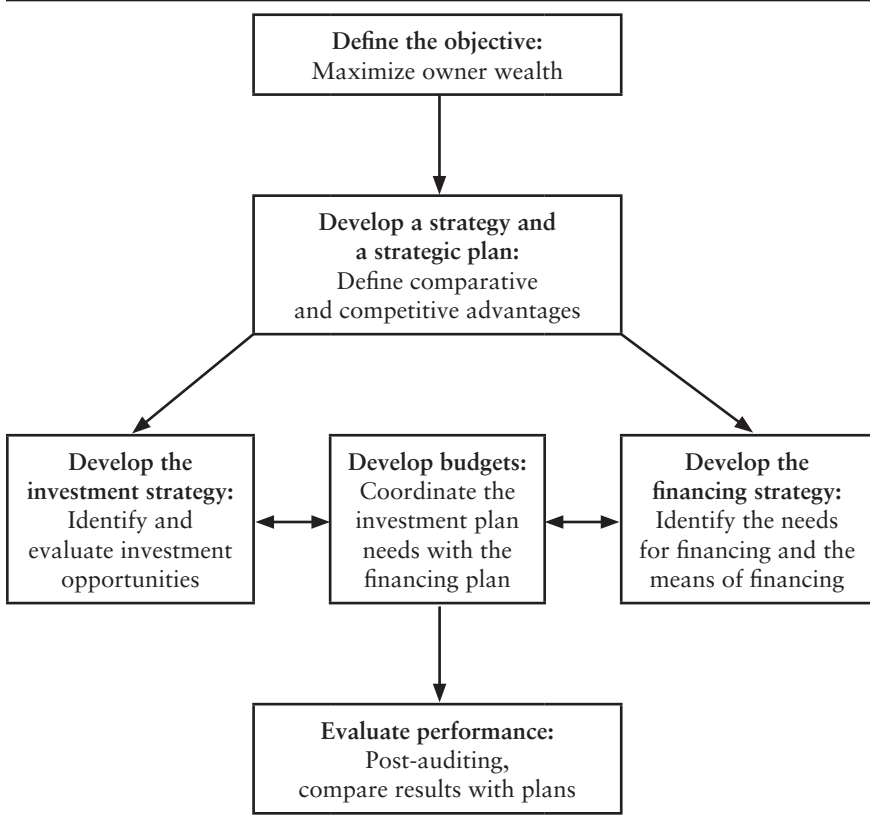

take a close look at the master budget, which is a system of budgets, a series of schedules, and budgeted statements. However, the budget system cannot be examined in isolation, so it is important to examine how the budget and the company’s strategic planning are connected. The investment strategy, which relates closely with the company’s capital budget, is considered in Part Two of the book; the company’s financing strategy, which is its long-term capital structure, was discussed in Chapter 2; and the evaluation of a company’s performance is discussed in Part Three of this book.

STRATEGY AND VALUE

The strategic plan is the path that the company intends to follow to achieve its objective, which is to put its assets to their best use, adding value. In this stra-

tegic plan is a method to make investments that will add value to the company. The way to add value is to invest in projects that have positive net present values. But where do these positive net present values come from? They come from the company's comparative advantage or its competitive advantages.

Comparative and Competitive Advantages

A *comparative advantage* is the advantage one company has over others in terms of the cost of producing or distributing goods or services. For example, Wal-Mart Stores, Inc. had for years a comparative advantage over its competitors (such as Kmart) through its vast network of warehouses and its distribution system. Wal-Mart invested in a system of regional warehouses and its own trucking system. Combined with bulk purchases and a unique customer approach (such as its "greeters"), Wal-Mart's comparative advantages in its warehousing and distribution systems helped it grow to be a major (and very profitable) retailer in a very short span of time. However, as with most comparative advantages, it took a few years for competitors to catch up and for Wal-Mart's advantage to disappear.

A *competitive advantage* is the advantage one company has over another because of the structure of the markets, input and output markets, in which they both operate. For example, one company may have a competitive advantage due to barriers to other companies entering the same market. This happens in the case of governmental regulations that limit the number of companies in a market, as with banks, or in the case of government-granted monopolies. A company itself may create barriers to entry (although with the help of the government) that include patents and trademarks. NutraSweet Company, a unit of Monsanto Company, had the exclusive patent on the artificial sweetener, aspartame, which it marketed under the brand name NutraSweet. However, this patent expired December 14, 1992. The loss of the monopoly on the artificial sweetener reduced the price of aspartame from \$70 per pound to \$20–35 per pound, since other companies could produce and sell aspartame products starting December 15, 1992.¹ NutraSweet had a competitive advantage as long as it had the patent. But as soon as the patent expired, this competitive advantage was lost and competitors were lining up to enter the market.

Only by having some type of advantage can a company invest in something and get more back in return. So first, a CFO has to figure out where the company has a comparative or competitive advantage before he or she can determine the company's strategy.

¹ Lois Therrien, Patrick Oster, and Chuck Hawkins, "How Sweet It Isn't at NutraSweet," *BusinessWeek* (December 14, 1992), p. 42. Monsanto sold its sweetener division in 2000.

Strategy and Adding Value

Often companies conceptualize a strategy in terms of the consumers of the company's goods and services. For example, a CFO may have a strategy to become the world's leading producer of microcomputer chips by producing the best quality chip or by producing chips at the lowest cost, developing a cost (and price) advantage over its competitors. So the CFO's focus is on product quality and cost. Is this strategy in conflict with maximizing owners' wealth? No.

To add value, the CFO must focus on the returns and risks of future cash flows to stockholders. And we look at a project's net present value when we make decisions regarding whether to invest in it. A strategy of gaining a competitive or comparative advantage is consistent with maximizing shareholder wealth. This is because projects with positive net present value arise when the company has a competitive or comparative advantage over other companies.

Suppose a new piece of equipment is expected to generate a return greater than what is expected for the project's risk (its cost of capital). But how can a company create value simply by investing in a piece of equipment? How can it maintain a competitive advantage? If investing in this equipment can create value, wouldn't the company's competitors also want this equipment? Of course—if they could use it to create value, they would surely be interested in it.

Now suppose that the company's competitors face no barriers to buying the equipment and exploiting its benefits. What will happen? The company and its competitors will compete for the equipment, bidding up its price. When does it all end? When the net present value of the equipment is zero.

Suppose instead that the company has a patent on the new piece of equipment and can thus keep its competitors from exploiting the equipment's benefits. Then there would be no competition for the equipment and the company would be able to exploit it to add value.

Consider an example where trying to gain a comparative advantage went wrong. Schlitz Brewing Company attempted to reduce its costs to gain an advantage over its competitors: It reduced its labor costs and shortened the brewing cycle. Reducing costs allowed it to reduce its prices below competitors' prices. But product quality suffered—so much that Schlitz lost market share, instead of gaining it.

Schlitz Brewing, for example, attempted to gain a comparative advantage, but was not true to a larger strategy to satisfy its customers—who

apparently wanted quality beer more than they wanted cheap beer. And the loss of market share was reflected in Schlitz's declining stock price.²

Value can be created only when the company has a competitive or comparative advantage. If a company analyzes a project and determines that it has a positive net present value, the first question should be: Where did it come from?

FINANCIAL PLANNING AND BUDGETING

A strategy is the direction a firm takes to meet its objective. A strategic plan is how a firm intends to go in that direction. For the CFO, a strategic investment plan includes policies to seek out possible investment opportunities: Do we spend more on research and development? Do we look globally? Do we attempt to increase market share?

A strategic plan also includes resource allocation. If a firm intends to expand, where does it get the capital to do so? If a firm requires more capital, the timing, amount, and type of capital (whether equity or debt) comprise elements of a firm's financial strategic plan. These things must be planned to implement the strategy.

IMPORTANCE OF FINANCIAL PLANNING

Financial planning allocates a firm's resources to achieve its investment objectives. Financial planning is important for several reasons.

First, financial planning helps managers assess the impact of a particular strategy on their firm's financial position, its cash flows, its reported earnings, and its need for external financing.

Second, by formulating financial plans, the CFO is in a better position to react to any changes in market conditions, such as slower than expected sales, or unexpected problems, such as a reduction in the supply of raw materials. By constructing a financial plan, the CFO becomes more familiar with the sensitivity of the firm's cash flows and its financing needs to changes in sales or some other factor.

Third, creating a financial plan helps the CFO understand the trade-offs inherent in its investment and financing plans. For example, by developing a financial plan, the CFO is better able to understand the trade-off that exists

² The case of Schlitz Brewing is detailed in George S. Day and Liam Fahey, "Putting Strategy into Shareholder Value Analysis," *Harvard Business Review* (March–April 1990), pp. 156–162.

between having sufficient inventory to satisfy customer demands and the need to finance the investment in inventory.

Financial planning consists of the firm’s investment and financing plans. Once we know the firm’s investment plan, the CFO needs to figure out when funds are needed and where they will come from. This is accomplished by developing a *budget*, which is basically the firm’s investment and financing plans expressed in dollar terms. A budget can represent details such as what to do with cash in excess of needs on a daily basis, or it can reflect broad statements of a firm’s business strategy over the next decade. Figure 6.2 illustrates the budgeting process.

Budgeting for the short term (less than a year) is usually referred to as *operational budgeting*; budgeting for the long term (typically three to five years ahead) is referred to as *long-run planning* or *long-term planning*. But since long-term planning depends on what is done in the short term, the operational budgeting and long-term planning are closely related.

FIGURE 6.2 The Budgeting Process of a Firm

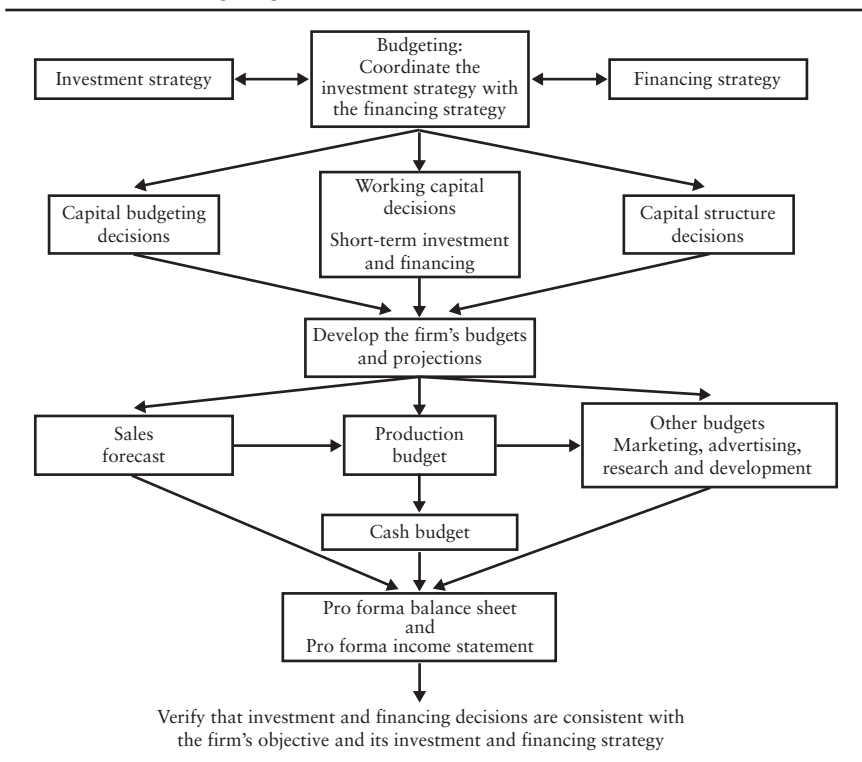

BUDGETING PROCESS

The budgeting process involves putting together the financing and investment strategy in terms that allow the CFO to determine what investments can be made and how these investments should be financed. In other words, budgeting pulls together decisions regarding capital budgeting, capital structure, and working capital.

Consider Sears. Its store renovation plan is part of its overall strategy of regaining its share of the retail market by offering customers better quality and service. Fixing up its stores is seen as an investment strategy. Sears evaluates its renovation plan using capital budgeting techniques (e.g., net present value). But the renovation program requires financing—this is where the capital structure decision comes in. If it needs more funds, where do they come from? Debt? Equity? Both? And let's not forget the working capital decisions. As Sears renovates its stores, will this change its need for cash on hand? Will the renovation affect inventory needs? If Sears expects to increase sales through this program, how will this affect its investment in accounts receivable? And what about short-term financing? Will Sears need more or less short-term financing when it renovates?

While Sears is undergoing a renovation program, it needs to estimate what funds it needs, in both the short run and the long run. This is where a cash budget and pro forma financial statements are useful. The starting point is generally a sales forecast, which is related closely to the purchasing, production, and other forecasts of the firm. What are Sears's expected sales in the short term? In the long term? Also, the amount that Sears expects to sell affects its purchases, sales personnel, and advertising forecasts. Putting together forecasts requires cooperation among Sears's marketing, purchasing, and finance staff.

Once Sears has its sales and related forecasts, the next step is a cash budget, detailing the cash inflows and outflows each period. Once the cash budget is established, pro forma balance sheet and income statements can be constructed. Following this, Sears must verify that its budget is consistent with its objective and its strategies.

Budgeting generally begins four to six months prior to the end of the current fiscal period. Most firms have a set of procedures that must be followed in compiling the budget. The budget process is usually managed by either the CFO, a vice president of planning, the director of the budget, the vice president of finance, or the controller. Each division or department provides its own budgets that are then merged into a firm's centralized budget by the manager of the budget.

A budget looks forward and backward. It identifies resources the firm will generate or need in the near and long term, and it serves as a measure

of the current and past performance of departments, divisions, or individual managers. But we have to be careful when we measure deviations between budgeted and actual results. We must separately identify deviations that were controllable from deviations that were uncontrollable. For example, suppose we develop a budget expecting \$10 million sales from a new product. If actual sales turn out to be \$6 million, do we interpret this result as poor performance on the part of management? Maybe, maybe not: If the lower-than-expected sales are due to an unexpected downturn in the economy, probably not; but yes, if they are due to what turns out to be obviously poor management forecasts of consumer demand.

SALES FORECASTING

Sales forecasts are an important part of financial planning. Inaccurate forecasts can result in shortages of inventory, inadequate short-term financing arrangements, and so on.

If a firm's sales forecast misses its mark, either understating or overstating sales, there are many potential problems. Consider Coleco Industries, which missed its mark. This company introduced a toy product in 1983, its Cabbage Patch doll, which enjoyed runaway popularity. In fact, this doll was so popular that Coleco could not keep up with demand. It was in such demand and inventory so depleted that fights broke out in toy stores, some parents bribed store personnel to get scarce dolls just before Christmas, and fake dolls were being smuggled into the country.

Coleco missed its mark, significantly underestimating the demand for these dolls. While having a popular toy may seem like a dream for a toy manufacturer, this doll turned into a nightmare. With no Cabbage Patch dolls on the toy shelves, other toy manufacturers introduced dolls with similar (but not identical) features, capturing some of Coleco's market. Also, many consumers—the parents—became irate at Coleco's creating the demand for the toy through advertising, but not having sufficient dolls to satisfy the demand.

Coleco Industries tried but failed to introduce a toy as successful as the Cabbage Patch doll. It filed for bankruptcy in 1988, with most of its assets (including its Cabbage Patch doll line) sold to Hasbro Inc., a rival toy company. Hasbro was then acquired by Mattel, Inc.

To predict cash flows we forecast sales, which are uncertain because they are affected by future economic, industry, and market conditions. Nevertheless, we can usually assign meaningful degrees of uncertainty to our forecasts. We forecast sales in one of the following ways:

- Regression analysis
- Market surveys
- Opinions of management

Forecasting with Regression Analysis

Regression analysis is a statistical method that enables us to *fit* a straight line that on average represents the best possible graphical relationship between sales and time. This best *fit* is called the *regression line*. One way regression analysis can be used is to simply extrapolate future sales based on the trend in past sales. Another way of using regression analysis is to look at the relation between two measures, say, sales and capital expenditures.

While regression analysis gives us what may seem to be a precise measure of the relationship among variables, there are a number of warnings that the CFO must heed in using it:

- Using historical data to predict the future assumes that the past relationships will continue into the future, which is not always true.
- The period over which the regression is estimated may not be representative of the future. For example, data from a recessionary period of time will not tell much about a period that is predicted to be an economic boom.
- The reliability of the estimate is important: If there is a high degree of error in the estimate, the regression estimates may not be useful.
- The time period over which the regression is estimated may be too short to provide a basis for projecting long-term trends.
- The forecast of one variable may require forecasts of other variables. For example, the CFO may be convinced that sales are affected by gross domestic product (GDP) and use regression to analyze this relationship. But to use regression to forecast sales, the CFO must first forecast GDP. In this case, the CFO's forecast of sales is only as good as the forecast of GDP.

Market Surveys

Market surveys of customers can provide estimates of future revenues. In the case of IBM, for example, the CFO would need to focus on the computer industry and, specifically, on the personal computer, minicomputer, and mainframe computer markets. For each of these markets, the CFO would have to assess IBM's market share and also the expected sales for each market. The CFO should expect to learn from these market surveys:

- Product development and introductions by IBM and its competitors.
- The general economic climate and the projected expenditures on computers.

In general, a CFO can use the firm's own market survey department to survey its customers. Or it can employ outside market survey specialists.

Management Forecasts

In addition to market surveys, the firm's managers may be able to provide forecasts of future sales. The experience of a firm's management and their familiarity with the firm's products, customers, and competitors make them reliable forecasters of future sales.

The firm's own managers should have the expertise to predict the market for the goods and services and to evaluate the costs of producing and marketing them. But there are potential problems in using management forecasts. Consider the case of a manager who forecasts rosy outcomes for a new product. These forecasts may persuade the firm to allocate more resources—such as a larger capital budget and additional personnel—to that manager. If these forecasts come true, the firm will be glad these additional resources were allocated. But if these forecasts turned out to be too rosy, the firm has unnecessarily allocated these resources.

Forecasting is an important element in planning for both the short-term and the long-term. But forecasts are made by people. Forecasters tend to be optimistic, which usually results in rosier-than-deserved forecasts of future sales. In addition, people tend to focus on what worked in the past, so past successes carry more weight in developing forecasts than an analysis of the future.

One way to avoid this is to make managers responsible for their forecasts, rewarding accurate forecasts and penalizing managers for being way off the mark.

SEASONAL CONSIDERATIONS

The operating activities of a firm typically vary throughout the year, depending on seasonal demand and supply factors. Seasonality influences a firm's short-term investment and financing activities.

Let us look at a few U.S. corporations' quarterly revenues to get an idea of different seasonal patterns of activity:

- Coca Cola, a beverage producer

- Amazon.com, an online retailer
- Walt Disney, a film and amusement firm
- Nike, a shoe manufacturer
- Delta Airlines, a national airline

The quarterly revenues for each of these firms is plotted in Figure 6.3 from the first quarter 2003 through the third quarter 2006. The seasonal patterns are quite different:

- Coca Cola tends to have increased sales in the summer months, driven, most likely, by their larger segment, soft drinks.
- Amazon.com has a high degree of seasonality, with sales dependent on the December holiday season, with sales highest in the fourth quarter.
- Walt Disney Company has sales that tend to increase around the fourth quarter of each year, influenced by their two major product lines, film production and amusement parks.
- Nike has seasonal sales, with sales increasing around the “back-to-school” time of year
- Delta Airlines’ sales increase somewhat during the summer months, due to summer vacation travel, but this seasonality is not as pronounced as that of, say, Nike or Disney.

FIGURE 6.3 Revenues of Selected U.S. Companies, Quarterly First Quarter 2003 through Third Quarter 2006

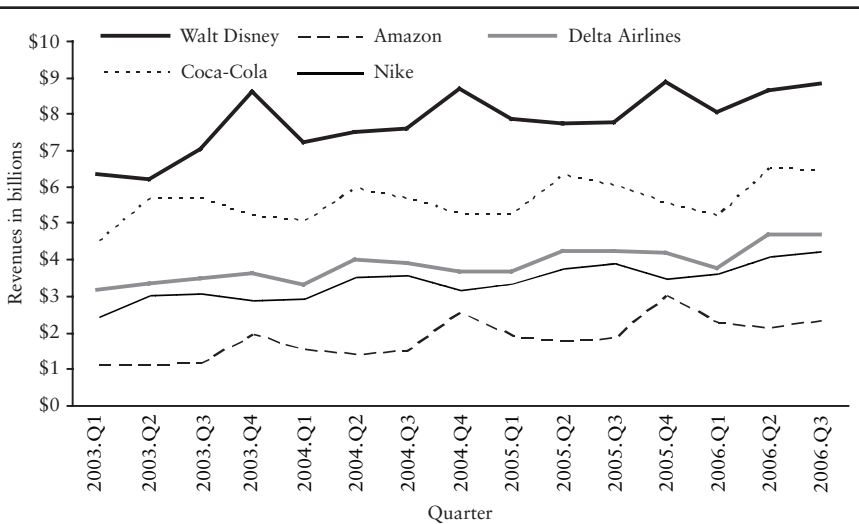

Source: Company annual reports and 10-Q filings, various years.

Looking closer at what seasonality has to do with cash flows, let's focus on the likely cash flow pattern for Amazon.com. Sales are greatest in the fourth quarter of the year due to holiday shopping. As a retail operation that does not extend credit, its cash inflows will be highest in the fourth quarter also.

But what about cash *outflows*? To have the merchandise to sell in the fourth quarter, Amazon.com must increase its inventory prior to or during the fourth quarter. Depending on its credit arrangements with its suppliers, cash will be flowing out of the firm before or during the fourth quarter. This means that for some period of time Amazon.com will have more cash going out than coming in, and then more cash coming in than going out.

BUDGETING

In budgeting, we bring together analyses of cash flows, projected income statements, and projected balance sheets. The cash flow analyses are most important, though the CFO needs to generate the income statement and balance sheet as well.

Most firms extend or receive credit, so cash flows and net income do not coincide. Typically, the CFO must determine cash flows from accounting information on revenues and expenses. Combining sales projections with estimates of collections of accounts receivable results in an estimate of cash receipts.

How are sales estimates translated into cash receipts? First, the CFO needs to estimate how long it takes to collect accounts. The CFO can estimate the typical time it takes to collect on accounts using the financial ratio,

$$\text{Number of days of credit} = \frac{\text{Accounts receivable}}{\text{Credit sales per day}}$$

This ratio indicates how long it takes, on average, to collect on accounts receivable.

An alternative and more precise method is to look at the *aging of receivables*—how long each account has been outstanding—and use this information to track collections. However, this requires a detailed estimate of the age of all accounts and their typical collection period.

Whether an overall average or an aging approach is used, the CFO needs to consider several factors in the cash collections estimate:

- An estimate of bad debts—accounts that will not be collected at all.
- An analysis of the trend in the number of days it takes customers to pay on account.

- An estimate of the seasonal nature of collections of accounts; often customers' ability to pay is influenced by the operating cycle of their own firm.

As with revenues and cash receipts, there is a relation between expenses and cash disbursements. Firms typically do not pay cash for all goods and services; purchases are generally bought on account (creating accounts payable) and wages and salaries are paid periodically (weekly, bi-monthly, or monthly). Therefore, there's a lagged relationship between expenses and cash payments.

An idea of the time it takes to pay for purchases on account with the number of days of purchases can be obtained from the following ratio:

$$\text{Number of days of purchases} = \frac{\text{Accounts payable}}{\text{Average day's purchases}}$$

The time it takes to pay for wages and salaries can be estimated by looking at the firm's personnel policies. Putting these two pieces together, the estimate of how long it takes to pay for the goods and services can be acquired.

Cash Budget

A *cash budget* is a detailed statement of the cash inflows and outflows expected in future periods. This budget helps the CFO identify financing and investment needs. A cash budget can also be used to compare actual cash flows against planned cash flows so that the CFO can evaluate both management's performance and management's forecasting ability.

Cash flows come into the firm from:

- Operations, such as receipts from sales and collections on accounts receivable.
- The results of financing decisions, such as borrowings, sales of shares of common stock, and sales of preferred stock.
- The results of investment decisions, such as sales of assets and income from marketable securities.

Cash flows leave the firm from:

- Operations, such as payments on accounts payable, purchases of goods, and the payment of taxes.
- Financing obligations, such as the payment of dividends and interest, and the repurchase of shares of stock or the redemption of bonds.
- Investments, such as the purchase of plant and equipment.

As we noted before, the cash budget is driven by the sales forecast. Consider the following sales forecasts for the Imagined Company for January through June:

| Month | Forecasted Sales | Month | Forecasted Sales |
|----------|------------------|-------|------------------|
| January | \$1,000 | April | \$2,000 |
| February | 2,000 | May | 1,000 |
| March | 3,000 | June | 1,000 |

Using the forecasted sales, along with a host of assumptions about credit sales, collections on accounts receivable, payments for purchases, and financing, we can construct a cash budget, which tells us about the cash inflows and the cash outflows.

Let's look at Imagined's cash budget for January of Year 1. Sales are expected to be \$1,000. Now let's translate sales into cash flows, focusing first on the cash flows from operations.

Let's assume that an analysis of accounts receivable over the prior year, Year 0, reveals that:

- 10% of a month's sales are paid in the month of the sale.
- 60% of a month's sales are paid in the month following the sale.
- 30% of a month's sales are paid in the second month following the sale.

This means that only 10% of the \$1,000 sales, or \$100, is collected in January of Year 1. But this also means that in January Imagined collects 60% of Year 0's December sales and 30% of Year 0's November sales. If sales in December and November of Year 0 were \$1,000 and \$2,000, respectively, this means that January collections are:

| | | |
|--------------------------------------|------------|------------------|
| Collections on January Year 1 sales | \$100 | ← 10% of \$1,000 |
| Collections on December Year 0 sales | 600 | ← 60% of \$1,000 |
| Collections on November Year 0 sales | <u>600</u> | ← 30% of \$2,000 |
| Total cash inflow from collections | \$1,300 | |

Now let's look at the cash flows related to Imagined's payment for its goods. We first have to make an assumption about how much Imagined buys and when it pays for its goods and services. First, assume that Imagined has a cost of goods (other than labor) of 50%. This means that for every \$1 it sells, it has a cost of 50%. Next, assume that Imagined purchases goods two months in advance of when the firm sells them (this means the number of days of inventory is around 60 days). Finally, let's assume that Imagined

pays 20% of its accounts payable in the month it purchases the goods and 80% of its accounts payable in the month after it purchases the goods.

Putting this all together, we forecast that in January, Imagined will purchase 50% of March's forecasted sales, or 50% of \$3,000 = \$1,500. Imagined will pay 20% of these purchases in January, or 20% of \$1,500 = \$300. In addition, Imagined will be paying 80% of the purchases made in December of Year 0. And December of Year 0's purchases are 50% of *February* of Year 1's projected sales. So in January of Year 1, Imagined will pay 50% of 80% of \$2,000, which is 50% of \$1,600 or \$800.

We assume that Imagined has additional cash outflows for wages (5% of current month's sales) and selling and administrative expenses (also 10% of current month's sales). Imagined's cash outflows related to operations in January consist of:

| | | |
|---|------------|------------------|
| Payments of current month's purchases | \$300 | ← 20% of \$1,500 |
| Payments for previous month's purchases | 800 | ← 80% of \$1,600 |
| Wages | 50 | ← 5% of \$1,000 |
| Selling and administrative expenses | <u>100</u> | ← 10% of \$1,000 |
| Operating cash outflows | \$1,250 | |

The cash flows pertaining to Imagined Company's operations are shown in the top portion of Table 6.1. In January, there is a net cash inflow from operations of \$50. Extending what we did for January's cash flows to the next five months as well, we get a projection of cash inflows and outflows from operations. As you can see, there are net outflows from operations in February and March, and net inflows in other months.

But cash flows from operations do not tell us the complete picture. The CFO also considers Imagined's nonoperating cash flows. Does the firm intend to buy or retire any plant and equipment? Does it intend to retire any debt? Does it need to pay interest on any debt? And so on. These projections are inserted in the lower portion of Table 6.1.

But there is one catch here: Cash inflows must equal cash outflows (unless Imagined has found a way to create cash!). So the CFO has to decide where Imagined is going to get its cash if its *inflows* are less than its *outflows*. And we have to decide where it is going to invest its cash if its *outflows* are less than its *inflows*.

Let's assume that Imagined's CFO plans to borrow from one of its banks where it has a line of credit when it needs short-term financing and it will pay off its bank loans or invest in marketable securities (if it has no outstanding bank loans) if it has more cash than needed. In our example, let's group cash and marketable securities into one item, referred to as "cash."

TABLE 6.1 Imagined Company Monthly Cash Budget, January–June of Year 1

| | January | February | March | April | May | June |
|---|------------|------------|------------|------------|------------|------------|
| Sales | \$1,000 | \$2,000 | \$3,000 | \$2,000 | \$1,000 | \$1,000 |
| Operating Cash Flows | | | | | | |
| Cash Inflows | | | | | | |
| Collections on accounts receivables: | | | | | | |
| Collections on current month's sales | \$100 | \$200 | \$300 | \$200 | \$100 | \$100 |
| Collections from previous month's sales | 600 | 600 | 1,200 | 1,800 | 1,200 | 600 |
| Collections from two months' previous sales | <u>600</u> | <u>300</u> | <u>300</u> | <u>600</u> | <u>900</u> | <u>600</u> |
| Operating cash inflows | \$1,300 | \$1,100 | \$1,800 | \$2,600 | \$2,200 | \$1,300 |
| Cash Outflows | | | | | | |
| Payments of purchases on account: | | | | | | |
| Payments for current month's purchases | \$300 | \$200 | \$100 | \$100 | \$100 | \$100 |
| Payments for previous month's purchases | 800 | 1,200 | 800 | 400 | 400 | 400 |
| Wages | 50 | 100 | 150 | 100 | 50 | 50 |
| Selling and administrative expenses | <u>100</u> | <u>200</u> | <u>300</u> | <u>200</u> | <u>100</u> | <u>100</u> |
| Operating cash outflows | \$1,250 | \$1,700 | \$1,350 | \$800 | \$650 | \$650 |
| Operating net cash flow | \$50 | (\$600) | \$450 | \$1,800 | \$1,550 | \$650 |
| Nonoperating Cash Flows | | | | | | |
| Cash Inflows | | | | | | |
| Retirements of plant and equipment | \$0 | \$0 | \$0 | \$500 | \$0 | \$0 |
| Issuance of long-term debt | 0 | 3,000 | 0 | 0 | 0 | 0 |
| Issuance of common stock | <u>0</u> | <u>0</u> | <u>0</u> | <u>0</u> | <u>0</u> | <u>0</u> |
| Nonoperating cash inflows | \$0 | \$3,000 | \$0 | \$500 | \$0 | \$0 |

TABLE 6.1 (Continued)

| | January | February | March | April | May | June |
|---|------------|------------|------------|------------|------------|------------|
| Cash Outflows | | | | | | |
| Acquisitions of plant and equipment | \$1,000 | \$3,000 | \$0 | \$0 | \$3,500 | \$0 |
| Payment of cash dividends | 0 | 0 | 100 | 0 | 0 | 100 |
| Retirement of long-term debt | 0 | 0 | 0 | 0 | 0 | 1,000 |
| Retirement of common stock | 0 | 0 | 0 | 0 | 0 | 0 |
| Interest on long-term debt | 10 | 10 | 10 | 10 | 10 | 10 |
| Taxes | 69 | 165 | 271 | 168 | 53 | 53 |
| Nonoperating cash outflows | \$1,079 | \$3,175 | \$381 | \$178 | \$3,563 | \$1,163 |
| Nonoperating cash flows | -\$1,079 | -\$175 | -\$381 | \$322 | -\$3,563 | -\$1,163 |
| Analysis of cash and marketable securities | | | | | | |
| Balance, beginning of month | \$1,500.00 | \$1,000.00 | \$1,000.00 | \$1,069.25 | \$2,000.00 | \$1,000.00 |
| Net cash flows for the month | (1,029.00) | (775.33) | 69.25 | 2,122.34 | (2,012.55) | (513.05) |
| Balance without any change in bank loans | \$471.00 | \$224.67 | \$1,069.25 | \$3,191.59 | (\$12.55) | \$486.95 |
| Bank loans to maintain minimum balance | 529.00 | 775.33 | 0.00 | 0.00 | 1,012.55 | 513.05 |
| Available to pay off bank loans | 0.00 | 0.00 | 0.00 | 1,191.59 | 0.00 | 0.00 |
| Balance, end of month | \$1,000.00 | \$1,000.00 | \$1,069.25 | \$2,000.00 | \$1,000.00 | \$1,000.00 |

Assumptions:

- (1) Cash sales are 10% of current month's sales.
- (2) Collections on accounts receivable are 60% of previous month's sales and 30% of the previous two month's sales.
- (3) Purchases are 50% of two-months-ahead sales.
- (4) Payments on accounts are 20% of current month's purchases, plus 80% of previous month's purchases.
- (5) Wages are 5% of current month's sales.
- (6) Selling and administrative expenses are 10% of current month's sales.
- (7) July and August sales are forecasted to be \$1,000 each month.

The bank loan–marketable securities decision is a residual decision: The CFO’s or controller’s staff makes policy decisions about such things as when the firm pays out accounts, but we use the bank loan or marketable securities investment as a “plug” figure to help balance the cash inflows and outflows. This plug is very important—it tells the CFO what financing arrangement needs to be in place (such as a line of credit) or that the CFO needs to make decisions regarding short-term investments.

Comparing inflows with outflows from operations, we see that if Imagined requires a minimum cash balance of \$1,000, it needs to use bank financing in January, February, May, and June. The CFO can also see that if Imagined does not need to maintain a cash balance above \$2,000, it can pay off some of its bank loans in April.

Table 6.1 provides a forecast of cash inflows and outflows for several months into the future. But these are forecasts and lots of things can happen between now and then. The actual cash flows can easily differ from the forecasted cash flows. Furthermore, a host of assumptions and decisions have been made by the staff along the way, some that the CFO via the board may be able to influence, such as dividend payments, and some that the CFO has no control over, such as how long customers take to pay. Economic conditions, market conditions, and other factors will affect actual cash flows.

Two tools that can help the CFO assess the uncertainty of cash flows are sensitivity analysis and simulation analysis. *Sensitivity analysis* involves changing one of the variables in the analysis and looking at its affect on the cash flows. This gives the CFO an idea of what cash flows may be under certain circumstances. The CFO can pose different scenarios: What if customers take 60 days to pay instead of 30? What if sales are actually \$1,000 in February instead of \$2,000?

But sensitivity analysis can become unmanageable if we start changing two or more things at a time. A manageable approach to doing this is with computer simulation. *Simulation analysis* allows the CFO to develop a probability distribution of possible outcomes, given a probability distribution for each variable that may change.

Suppose the CFO can develop a probability distribution—that is, a list of possible outcomes and their related likelihood of occurring—for sales. (A probability distribution is the set of possible outcomes and their likelihood of occurrence.) And suppose the CFO can develop a probability distribution for costs of the raw materials that are needed in producing the product. Using simulation, a probability distribution of cash flows can be produced, providing information on the uncertainty of the firm’s future cash flows, as shown in Figure 6.4. Once a staff member produces the probability distribution of future cash flows, the CFO has an idea of the possible cash flows and can plan accordingly. The cash budget produced using the possible cash

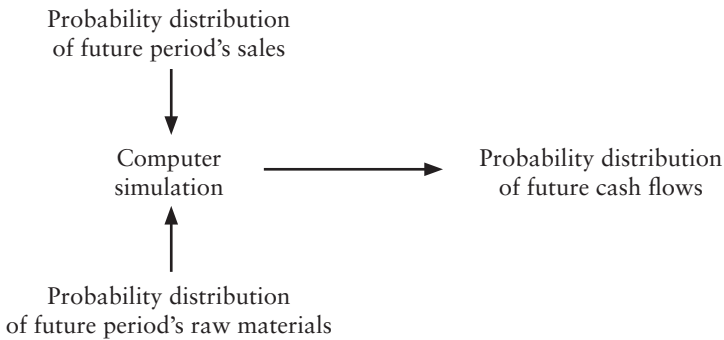
FIGURE 6.4 Simulation and Cash Flow Uncertainty

flows is a *flexible budget*. With this information, the CFO can then determine the more appropriate short-term financing and short-term investments to consider.

PRO FORMA FINANCIAL STATEMENTS

A *pro forma balance sheet* is a projected balance sheet for a future period—a month, quarter, or year—that summarizes assets, liabilities, and equity. A *pro forma income statement* is the projected income statement for a future period—a month, quarter, or year—that summarizes revenues and expenses. Together both projections help the CFO identify the firm's investment and financing needs.

The analysis of accounts and percent-of-sales methods are two ways of projecting financial statements.

Analysis of Accounts

The *analysis of accounts method* starts with the cash budget. Before putting together the pro forma income statement and balance sheet, the CFO needs to see how the various asset, liability, and equity accounts change from month to month, based on the information provided in the cash budget. The analysis of accounts is shown in Table 6.2, where each account is analyzed starting with the beginning balance and making any necessary adjustments to arrive at the ending balance.

The CFO can see how the cash budget interacts with the pro forma income statement and balance sheet by looking at the change in accounts receivable. Consider what happens in January of Year 1:

TABLE 6.2 Imagined Company Analysis of Monthly Changes in Accounts, January–June of Year 1

| | January | February | March | April | May | June |
|--|--------------|--------------|--------------|--------------|--------------|--------------|
| Accounts receivable | | | | | | |
| Month's beginning balance | \$2,000 | \$1,700 | \$2,600 | \$3,800 | \$3,200 | \$2,000 |
| plus credit sales during the month | 900 | 1,800 | 2,700 | 1,800 | 900 | 900 |
| less collections on accounts | <u>1,200</u> | <u>900</u> | <u>1,500</u> | <u>2,400</u> | <u>2,100</u> | <u>1,200</u> |
| Month's ending balance | \$1,700 | \$2,600 | \$3,800 | \$3,200 | \$2,000 | \$1,700 |
| Inventory | | | | | | |
| Month's beginning balance | \$2,500 | \$3,500 | \$3,500 | \$2,500 | \$2,000 | \$2,000 |
| plus purchases | 1,500 | 1,000 | 500 | 500 | 500 | 500 |
| plus wages and other production expenses | 50 | 100 | 150 | 100 | 50 | 50 |
| less goods sold | <u>550</u> | <u>1,100</u> | <u>1,650</u> | <u>1,100</u> | <u>550</u> | <u>550</u> |
| Month's ending balance | \$3,500 | \$3,500 | \$2,500 | \$2,000 | \$2,000 | \$2,000 |
| Accounts payable | | | | | | |
| Month's beginning balance | \$2,000 | \$2,400 | \$2,000 | \$1,600 | \$1,600 | \$1,600 |
| plus purchases on account | 1,200 | 800 | 400 | 400 | 400 | 400 |
| less payments on account | <u>800</u> | <u>1,200</u> | <u>800</u> | <u>400</u> | <u>400</u> | <u>400</u> |
| Month's ending balance | \$2,400 | \$2,000 | \$1,600 | \$1,600 | \$1,600 | \$1,600 |
| Bank loans | | | | | | |
| Month's beginning balance | \$1,000 | \$1,529 | \$2,304 | \$2,304 | \$1,113 | \$2,125 |
| plus borrowings | 529 | 775 | 0 | 0 | 1,013 | 513 |
| less repayment of loans | <u>0</u> | <u>0</u> | <u>0</u> | <u>1,192</u> | <u>0</u> | <u>0</u> |
| Month's ending balance | \$1,529 | \$2,304 | \$2,304 | \$1,113 | \$2,125 | \$2,638 |
| Plant and equipment | | | | | | |
| Month's beginning balance | \$10,000 | \$10,890 | \$13,751 | \$13,614 | \$12,982 | \$16,318 |
| plus acquisitions | 1,000 | 3,000 | \$0 | 0 | 3,500 | 0 |
| less retirements | 0 | 0 | 0 | 500 | 0 | 0 |
| less depreciation ^a | <u>110</u> | <u>139</u> | <u>137</u> | <u>131</u> | <u>165</u> | <u>163</u> |
| Month's ending balance | \$10,890 | \$13,751 | \$13,614 | \$12,982 | \$16,318 | \$16,154 |
| Long-term debt | | | | | | |
| Month's beginning balance | \$5,000 | \$5,000 | \$8,000 | \$8,000 | \$8,000 | \$8,000 |
| plus issuances of long-term debt | 0 | 3,000 | 0 | 0 | 0 | 0 |
| less retirements of long-term debt | <u>0</u> | <u>0</u> | <u>0</u> | <u>0</u> | <u>0</u> | <u>1,000</u> |
| Month's ending balance | \$5,000 | \$8,000 | \$8,000 | \$8,000 | \$8,000 | \$7,000 |
| Common equity | | | | | | |
| Month's beginning balance | \$8,000 | \$8,161 | \$8,547 | \$9,079 | \$9,470 | \$9,592 |
| plus earnings retained during the month | 161 | 386 | 532 | 391 | 123 | 24 |
| plus issuances of common stock | 0 | 0 | 0 | 0 | 0 | 0 |
| less retirements of common stock | <u>0</u> | <u>0</u> | <u>0</u> | <u>0</u> | <u>0</u> | <u>0</u> |
| Month's ending balance | \$8,161 | \$8,547 | \$9,079 | \$9,470 | \$9,592 | \$9,616 |

^a 1% of gross plant and equipment.

| The analysis of accounts receivable . . . | | . . . affects financial planning through the . . . | |
|---|---------------|--|--|
| Balance at the beginning of the month | \$2,000 | → | pro forma balance sheet (accounts receivable) |
| Plus credit sales during January | +900 | → | pro forma income statement (sales) and pro forma balance sheet (accounts receivable) |
| Less collections on accounts during January | <u>-1,200</u> | → | cash budget (cash flow from operations) |
| Balance at the end of the month | \$1,700 | → | pro forma balance sheet (accounts receivable) |

As can be seen, the balances in these accounts are all interrelated with the cash budget.

In doing a cash budget, the CFO has begun to make projections based on the following information:

- Changes in the cash account are determined by the difference between cash inflows and outflows.
- Changes in accounts receivables are determined by sales and collections projections.
- Changes in inventory are determined by purchase and sales projections.
- Changes in plant and equipment are determined by capital budgeting.
- Changes in long-term debt are determined by financing projections.
- Changes in common equity are determined by both the financing projections and the projected retained earnings.
- Changes in retained earnings are determined by the projected income.

If all these pieces are put together, the CFO has a pro forma balance sheet for Imagined Company, as shown in Table 6.3. Looking at the cash budget in Table 6.1, the analysis of accounts in Table 6.2, and the balance sheet in Table 6.3, the CFO can follow through to see the interactions among the various assets, liabilities, equity accounts, and cash flows as was done for accounts receivable.

The pro forma income statement for Imagined Company is shown in the lower part of Table 6.3. Though the CFO's interest is ultimately in cash flows, the income statement provides useful summary information on the expected performance of the firm in months to come. As can be seen in Table 6.3, net income tends to increase in March, which accompanies the increased revenues in that month.

TABLE 6.3 Imagined Company Monthly Pro Forma Balance Sheet and Income Statement, January–June of Year 1
Pro Forma Balance Sheet

| | January | February | March | April | May | June |
|--------------------------------|---------------|---------------|---------------|---------------|---------------|---------------|
| Assets | | | | | | |
| Cash and marketable securities | \$1,000 | \$1,000 | \$1,069 | \$2,000 | \$1,000 | \$1,000 |
| Accounts receivable | 1,700 | 2,600 | 3,800 | 3,200 | 2,000 | 1,700 |
| Inventories | 3,500 | 3,500 | 2,500 | 2,000 | 2,000 | 2,000 |
| Plant and equipment | <u>10,890</u> | <u>13,751</u> | <u>13,614</u> | <u>12,982</u> | <u>16,318</u> | <u>16,154</u> |
| Total Assets | \$17,090 | \$20,851 | \$20,983 | \$20,182 | \$21,318 | \$20,854 |
| Liabilities and equity | | | | | | |
| Accounts payable | \$2,400 | \$2,000 | \$1,600 | \$1,600 | \$1,600 | \$1,600 |
| Bank loans | 1,529 | 2,304 | 2,304 | 1,113 | 2,125 | 2,638 |
| Long-term debt | 5,000 | 8,000 | 8,000 | 8,000 | 8,000 | 7,000 |
| Common equity | <u>8,161</u> | <u>8,547</u> | <u>9,079</u> | <u>9,470</u> | <u>9,592</u> | <u>9,616</u> |
| Total Liabilities and Equity | \$17,090 | \$20,851 | \$20,983 | \$20,182 | \$21,318 | \$20,854 |

Pro Forma Income Statement

| | January | February | March | April | May | June |
|--|------------|------------|------------|------------|------------|------------|
| Sales | \$1,000 | \$2,000 | \$3,000 | \$2,000 | \$1,000 | \$1,000 |
| less cost of goods sold | 550 | 1,100 | 1,650 | 1,100 | 550 | 550 |
| less depreciation | <u>110</u> | <u>139</u> | <u>138</u> | <u>131</u> | <u>165</u> | <u>163</u> |
| Gross profit | \$340 | \$761 | \$1,212 | \$769 | \$285 | \$287 |
| less selling and administrative expenses | <u>100</u> | <u>200</u> | <u>300</u> | <u>200</u> | <u>100</u> | <u>100</u> |
| Earnings before interest and taxes | \$240 | \$561 | \$912 | \$569 | \$185 | \$187 |
| less interest | <u>10</u> | <u>10</u> | <u>10</u> | <u>10</u> | <u>10</u> | <u>10</u> |
| Earnings before taxes | \$230 | \$551 | \$902 | \$559 | \$175 | \$177 |
| less taxes | <u>69</u> | <u>165</u> | <u>271</u> | <u>168</u> | <u>53</u> | <u>53</u> |
| Net income | \$161 | \$386 | \$632 | \$391 | \$123 | \$124 |
| less cash dividends | <u>0</u> | <u>0</u> | <u>100</u> | <u>0</u> | <u>0</u> | <u>100</u> |
| Retained earnings | \$161 | \$386 | \$532 | \$391 | \$123 | \$24 |

The CFO is interested in the pro forma balance sheet and income statement not just as a product of the cash flow analysis. Suppose the bank financing is secured financing, limited to 80% of accounts receivable. If this is the case, the CFO may be limited as to how much can be borrowed from the bank in any particular month. The CFO is also interested in the balance sheet since some of the short-term or long-term debt may have covenants that prescribe the firm to maintain specific relations among its accounts,

for example, a current ratio of 2:1. In addition, the CFO may be concerned about the firm's perceived riskiness. If the CFO must borrow heavily at certain times within a year, does this affect the riskiness of the outstanding debt obligations, thereby increasing the cost of financing?

These considerations point out the importance of reviewing the projected balance sheet. In fact, these considerations may point out the need for the CFO to explicitly build constraints into the budget to ensure certain financial ratios are maintained each month. These constraints add complexity to an already complex system of relationships, the detail of which is beyond the scope of this text.

Percent-of-Sales Method

The *percent-of-sales method* uses historical relationships between sales and each of the other income statement accounts and between sales and each of the balance sheet accounts. There are two steps to this method.

First, previous periods' income statement and balance sheet accounts are restated in terms of a percentage of sales for the year. Let's look at the Imagined Corporation's balance sheet and income statement for Year 1 shown in the leftmost column of Table 6.4. Because we are projecting monthly sales, each item in both statements is restated as a percent of December Year 1 sales, as shown in the second column of this table.

Second, based on the forecasted sales for the future years and the percentages each account represents, projections for January through June are calculated. For example, cost of goods sold is 55% of sales. Because January sales are predicted to be \$1,000, cost of goods sold is predicted to be 55% of \$1,000, or \$550. And as sales for February is predicted to be \$2,000, cost of goods sold for February are predicted to be \$1,100. It is likewise for balance sheet accounts. Cash and marketable securities are 75% of monthly sales, so the CFO expects \$750 in this account in January. Each of the balance sheet and income statement accounts is forecasted January through June, as shown in Table 6.4.

This method of creating pro forma statements is simple. But it may make inappropriate assumptions, such as that: (1) all costs vary with sales, even though most firms have fixed costs; or (2) assets and liabilities change along with sales, even though firms tend to make capital investments that generate cash flows far into the future, not necessarily in the year they are put in place.

And there is another drawback: The percent-of-sales method focuses on accounts in the financial statements, not cash flows. Because of this, it cannot help the CFO identify when a firm needs cash and when it has excess cash to invest.

TABLE 6.4 Pro Forma Financial Statements for January–June of Year 1, Using the Percent-of-Sales Method
Pro Forma Balance Sheet

| | As of the End of Year 0 | Percentage of December Year 0 Sales | Forecasted Accounts for Year 1 | | | | | |
|----------------------------------|-------------------------------|---|--------------------------------|----------|----------|----------|---------|---------|
| | | | January | February | March | April | May | June |
| Cash and marketable securities | \$1,500 | 75% | \$750 | \$1,500 | \$2,250 | \$1,500 | \$750 | \$750 |
| Accounts receivable | 2,000 | 100% | 1,000 | 2,000 | 3,000 | 2,000 | 1,000 | \$1,000 |
| Inventories | 2,500 | 125% | 1,250 | 2,500 | 3,750 | 2,500 | 1,250 | \$1,250 |
| Plant and equipment | 10,000 | 500% | 5,000 | 10,000 | 15,000 | 10,000 | 5,000 | \$5,000 |
| Total Assets | \$16,000 | 800% | \$8,000 | \$16,000 | \$24,000 | \$16,000 | \$8,000 | \$8,000 |
| Accounts payable | \$2,000 | 100% | \$0 | \$0 | \$0 | \$0 | \$0 | \$0 |
| Bank loans | 1,000 | 50% | 500 | 1,000 | 1,500 | 1,000 | 500 | \$500 |
| Long-term debt | 5,000 | 250% | 2,500 | 5,000 | 7,500 | 5,000 | 2,500 | 2,500 |
| Common stock and paid-in capital | 2,000 | 100% | 1,000 | 2,000 | 3,000 | 2,000 | 1,000 | 1,000 |
| Retained earnings | 6,000 | 300% | 3,000 | 6,000 | 9,000 | 6,000 | 3,000 | 3,000 |
| Total Liabilities and Equity | \$16,000 | 800% | \$8,000 | \$16,000 | \$24,000 | \$16,000 | \$8,000 | \$8,000 |

TABLE 6.4 (Continued)
Pro Forma Income Statement

| | December Year 0 | Percentage of December Year 0 Sales | Forecasted Accounts for Year 1 | | | | | | |
|---|--------------------|---|--------------------------------|----------|---------|---------|---------|---------|---------|
| | | | January | February | March | April | May | June | |
| Sales | \$2,000 | 100% | \$1,000 | \$2,000 | \$3,000 | \$2,000 | \$2,000 | \$1,000 | \$1,000 |
| less cost of goods sold | 1,100 | 55% | 550 | 1,100 | 1,650 | 1,100 | 1,100 | 550 | 550 |
| less depreciation | 200 | 10% | 100 | 200 | 300 | 200 | 200 | 100 | 100 |
| Gross profit | \$700 | 35% | 350 | 700 | 1,050 | 700 | 700 | 350 | 350 |
| less selling and administrative expenses | 10 | 1% | 5 | 10 | 15 | 10 | 10 | 5 | 5 |
| Earnings before interest and taxes | \$690 | 35% | \$345 | \$690 | \$1,035 | \$690 | \$690 | \$345 | \$345 |
| less interest | 20 | 1% | 10 | 20 | 30 | 20 | 20 | 10 | 10 |
| Earnings before taxes | \$670 | 34% | \$335 | \$670 | \$1,005 | \$670 | \$670 | \$335 | \$335 |
| less taxes | 12 | 1% | 6 | 12 | 18 | 12 | 12 | 6 | 6 |
| Net income | \$658 | 33% | \$329 | \$658 | \$987 | \$658 | \$658 | \$329 | \$329 |
| Previous December's sales | \$1,000 | | | | | | | | |
| Previous November's sales | \$2,000 | | | | | | | | |

But the percent-of-sales method is used frequently because of its simplicity. And since we are dealing with forecasts, which are themselves estimates (and not actual fact), the simpler approach is sometimes more attractive.

LONG-TERM FINANCIAL PLANNING

Long-term planning is similar to what we have just completed for the operational budget for January through June of Year 1, but for a longer span of time into the future and with less detail.

Projections for Year 1 through Year 6 are shown in Table 6.5, where the cash budget is shown in panel A and the pro forma financial statements are shown in panel B. Notice that the CFO is not as concerned about the details, say, concerning the source of cash flows from operations, but rather the bottom line. However, these statements must be compiled as was done with the operational budget: Based on projections and assumptions that are built into our cash budget, the CFO integrates the investment decisions with the financing decisions.

By looking at the long-term plan, the CFO gets an idea of how the firm intends to meet its objective of maximizing shareholder wealth. For example, in the operational budget the CFO would be concerned about meeting monthly cash demands and we assume Imagined Company borrows from banks to meet any cash shortages. But with the long-term plan, the CFO can address the issue of what capital structure (the mix of debt and equity) the firm wants in the long-run. In the case of Imagined Company, in our illustration it is assumed that:

- Any bank loans are reduced to \$1,000 at the end of each year.
- When long-term capital is needed, the CFO raises one-half using debt, one-half issuing new equity.
- When the firm is able to reduce its reliance on external funds, it will reduce its long-term debt.

Long-term plans should be evaluated periodically as are operational budgets. And since the two are closely tied (what is done in the short-term influences what happens in the long-term), it is convenient to update both types of budgets simultaneously.

FINANCIAL MODELING

A *financial model* is the set of relationships that are behind the calculations performed in putting together the cash budget and the pro forma state-

TABLE 6.5 Imagined Company Long-Term Planning, Year 1–Year 6
Panel A Cash Budget

| Projected Sales | \$20,000 | \$22,000 | \$25,000 | \$26,000 | \$27,000 | \$28,000 |
|-------------------------------------|-----------------|-----------------|-----------------|-----------------|-----------------|-----------------|
| | Year 1 | Year 2 | Year 3 | Year 4 | Year 5 | Year 6 |
| Operating Cash Flows | | | | | | |
| Cash Inflows | | | | | | |
| Cash sales | \$2,000 | \$2,200 | \$2,500 | \$2,600 | \$2,700 | \$2,800 |
| Collections on account: | <u>19,000</u> | <u>19,820</u> | <u>21,250</u> | <u>22,040</u> | <u>24,100</u> | <u>26,270</u> |
| Operating cash inflows | \$21,000 | \$22,020 | \$23,750 | \$24,640 | \$26,800 | \$29,070 |
| Cash Outflows | | | | | | |
| Payments of purchases on account: | \$10,067 | \$10,917 | \$12,375 | \$12,958 | \$13,458 | \$13,958 |
| Wages | 1,000 | 1,100 | 1,250 | 1,300 | 1,350 | 1,400 |
| Selling and administrative expenses | <u>2,000</u> | <u>2,200</u> | <u>2,500</u> | <u>2,600</u> | <u>2,700</u> | <u>2,800</u> |
| Operating cash outflows | <u>\$13,067</u> | <u>\$14,217</u> | <u>\$16,125</u> | <u>\$16,858</u> | <u>\$17,508</u> | <u>\$18,158</u> |
| Operating net cash flows | \$7,933 | \$7,803 | \$7,625 | \$7,782 | \$9,292 | \$10,912 |
| Nonoperating Cash Flows | | | | | | |
| Cash inflows | | | | | | |
| Retirement of plant and equipment | \$500 | \$0 | \$0 | \$0 | \$1,000 | \$2,000 |
| Nonoperating cash inflows | \$500 | \$0 | \$0 | \$0 | \$1,000 | \$2,000 |
| Cash outflows | | | | | | |
| Maturing long-term debt | \$1,000 | \$1,000 | \$1,000 | \$1,000 | \$1,000 | \$1,000 |
| Acquisitions of plant and equipment | 10,000 | 7,500 | 7,500 | 5,000 | 1,000 | 5,000 |
| Payment of cash dividends | 400 | 400 | 400 | 400 | 400 | 400 |
| Interest on long-term debt | 0,300 | 0,350 | 0,400 | 0,350 | 0,300 | 0,250 |
| Taxes | <u>1,308</u> | <u>1,317</u> | <u>1,454</u> | <u>1,520</u> | <u>1,773</u> | <u>1,901</u> |
| Nonoperating cash outflows | \$13,008 | \$10,567 | \$10,754 | \$8,270 | \$4,473 | \$8,551 |
| Nonoperating net cash flows | -\$12,508 | -\$10,567 | -\$10,754 | -\$8,270 | -\$3,473 | -\$6,551 |
| Analysis of cash | | | | | | |
| Cash balance, beginning of year | \$1,500 | \$1,500 | \$1,500 | \$1,500 | \$1,500 | \$4,000 |
| Net cash flows during year | <u>-4,575</u> | <u>-2,764</u> | <u>-3,129</u> | <u>-488</u> | <u>5,819</u> | <u>4,360</u> |
| Cash balance without any financing | -\$3,075 | -\$1,264 | -\$1,629 | \$1,012 | \$7,319 | \$8,360 |
| Long-term debt issuance | 2,287 | 1,382 | 1,564 | 244 | 0 | 0 |
| Common stock issuance | 2,287 | 1,382 | 1,564 | 244 | 0 | 0 |
| Available to pay off long-term debt | <u>0</u> | <u>0</u> | <u>0</u> | <u>0</u> | <u>3,319</u> | <u>4,360</u> |
| Cash balance, end of year | \$1,500 | \$1,500 | \$1,500 | \$1,500 | \$4,000 | \$4,000 |

TABLE 6.5 (Continued)
Imagined Company Long-Term Planning, Analysis of Accounts

| | Year 1 | Year 2 | Year 3 | Year 4 | Year 5 | Year 6 |
|--|-----------------|---------------|---------------|---------------|---------------|---------------|
| Accounts receivable | | | | | | |
| Year's beginning balance | \$2,000 | \$1,000 | \$980 | \$2,230 | \$3,590 | \$3,790 |
| plus credit sales during the year | \$18,000 | 19,800 | 22,500 | 23,400 | 24,300 | 25,200 |
| less collections on accounts | <u>\$19,000</u> | <u>19,820</u> | <u>21,250</u> | <u>22,040</u> | <u>24,100</u> | <u>26,270</u> |
| Year's ending balance | \$1,000 | \$980 | \$2,230 | \$3,590 | \$3,790 | \$2,720 |
| Inventory | | | | | | |
| Year's beginning balance | \$2,500 | \$2,500 | \$2,500 | \$2,500 | \$2,500 | \$2,500 |
| plus purchases | 10,000 | 11,000 | 12,500 | 13,000 | 13,500 | 14,000 |
| plus wages and other production expenses | 1,000 | 1,100 | 1,250 | 1,300 | 1,350 | 1,400 |
| less goods sold | <u>11,000</u> | <u>12,100</u> | <u>13,750</u> | <u>14,300</u> | <u>14,850</u> | <u>15,400</u> |
| Year's ending balance | \$2,500 | \$2,500 | \$2,500 | \$2,500 | \$2,500 | \$2,500 |
| Accounts payable | | | | | | |
| Year's beginning balance | \$2,000 | \$1,933 | \$2,017 | \$2,142 | \$2,183 | \$2,225 |
| plus purchases on account | 10,000 | 11,000 | 12,500 | 13,000 | 13,500 | 14,000 |
| less payments on account | <u>10,067</u> | <u>10,917</u> | <u>12,375</u> | <u>12,958</u> | <u>13,458</u> | <u>13,958</u> |
| Year's ending balance | \$1,933 | \$2,017 | \$2,142 | \$2,183 | \$2,225 | \$2,267 |
| Bank loans | | | | | | |
| Year's beginning and ending balance | \$1,000 | \$1,000 | \$1,000 | \$1,000 | \$1,000 | \$1,000 |
| Plant and equipment | | | | | | |
| Year's beginning balance | \$10,000 | \$17,160 | \$21,701 | \$25,697 | \$27,013 | \$23,772 |
| plus acquisitions | 9,500 | 7,500 | 7,500 | 5,000 | | 3,000 |
| less depreciation | <u>2,340</u> | <u>2,959</u> | <u>3,504</u> | <u>3,684</u> | <u>3,242</u> | <u>3,213</u> |
| Year's ending balance | \$17,160 | \$21,701 | \$25,697 | \$27,013 | \$23,772 | \$23,559 |
| Long-term debt | | | | | | |
| Year's beginning balance | \$5,000 | \$6,287 | \$6,669 | \$7,234 | \$6,478 | \$2,159 |
| plus long-term debt issued | 2,287 | 1,382 | 1,564 | 244 | | |
| less long-term debt retired or matured | <u>1,000</u> | <u>1,000</u> | <u>1,000</u> | <u>1,000</u> | <u>4,319</u> | <u>5,360</u> |
| Year's ending balance | \$6,287 | \$6,669 | \$7,234 | \$6,478 | \$2,159 | -\$3,202 |
| Common equity | | | | | | |
| Year's beginning balance | \$8,000 | \$12,939 | \$16,995 | \$21,551 | \$24,942 | \$28,678 |
| plus issuance of new shares of stock | 2,287 | 1,382 | 1,564 | 244 | 0 | 0 |
| plus earnings retained during the year | <u>2,652</u> | <u>2,674</u> | <u>2,992</u> | <u>3,146</u> | <u>3,736</u> | <u>4,036</u> |
| Year's ending balance | \$12,939 | \$16,995 | \$21,551 | \$24,942 | \$28,678 | \$32,714 |

TABLE 6.5 (Continued)

Panel B Imagined Company Pro Forma Financial Statements, Year 1–Year 6
Pro Forma Balance Sheet

| | Year 1 | Year 2 | Year 3 | Year 4 | Year 5 | Year 6 |
|--------------------------------|---------------|---------------|---------------|---------------|---------------|---------------|
| Assets | | | | | | |
| Cash and marketable securities | \$1,500 | \$1,500 | \$1,500 | \$1,500 | \$4,000 | \$4,000 |
| Accounts receivable | 1,000 | 980 | 2,230 | 3,590 | 3,790 | 2,720 |
| Inventories | 2,500 | 2,500 | 2,500 | 2,500 | 2,500 | 2,500 |
| Plant and equipment | <u>17,160</u> | <u>21,701</u> | <u>25,697</u> | <u>27,013</u> | <u>23,772</u> | <u>23,559</u> |
| Total Assets | \$22,160 | \$26,681 | \$31,927 | \$34,603 | \$34,062 | \$32,779 |
| Liabilities and Equity | | | | | | |
| Accounts payable | \$1,933 | \$2,017 | \$2,142 | \$2,183 | \$2,225 | \$2,269 |
| Bank loans | 1,000 | 1,000 | 1,000 | 1,000 | 1,000 | 1,000 |
| Long-term debt | 6,287 | 6,669 | 7,234 | 6,478 | 2,159 | (3,202) |
| Stockholders' equity | <u>12,939</u> | <u>16,995</u> | <u>21,551</u> | <u>24,942</u> | <u>28,678</u> | <u>32,714</u> |
| Total Liabilities and Equity | \$22,160 | \$26,681 | \$31,927 | \$34,603 | \$34,062 | \$32,779 |

Pro Forma Income Statement

| | Year 1 | Year 2 | Year 3 | Year 4 | Year 5 | Year 6 |
|--|----------|----------|----------|----------|----------|----------|
| Sales | \$20,000 | \$22,000 | \$25,000 | \$26,000 | \$27,000 | \$28,000 |
| less cost of goods sold | 11,000 | 12,100 | 13,750 | 14,300 | 14,850 | 15,400 |
| less depreciation | 2,340 | 2,959 | 3,504 | 3,684 | 3,242 | 3,213 |
| Gross profit | \$6,660 | \$6,941 | \$7,746 | \$8,016 | \$8,908 | \$9,387 |
| less selling and administrative expenses | 2,000 | 2,200 | 2,500 | 2,600 | 2,700 | 2,800 |
| Earnings before interest and taxes | \$4,660 | \$4,741 | \$5,246 | \$5,416 | \$6,208 | \$6,587 |
| less interest | 300 | 350 | 400 | 350 | 300 | 250 |
| Earnings before taxes | \$4,360 | \$4,391 | \$4,846 | \$5,066 | \$5,908 | \$6,337 |
| less taxes | 1,308 | 1,317 | 1,454 | 1,520 | 1,773 | 1,901 |
| Net income | \$3,052 | \$3,074 | \$3,392 | \$3,546 | \$4,136 | \$4,436 |
| less cash dividends | 400 | 400 | 400 | 400 | 400 | 400 |
| Retained earnings | \$2,652 | \$2,674 | \$2,992 | \$3,146 | \$3,736 | \$4,036 |

ments. In financial modeling, the CFO generally focuses on the essential features of the budget and statements, and tries not to get bogged down in the details. In our Imagined Company example, we looked at the relation between cash and marketable securities, but we avoided getting into detail of where the cash is held or which securities the CFO would request a staff member to buy or sell.

In the case of Imagined Company, the following relations between cash inflows and sales are modeled:

$$\text{Cash inflows} = 10\% \left(\begin{array}{c} \text{This} \\ \text{month's} \\ \text{sales} \end{array} \right) + 60\% \left(\begin{array}{c} \text{Preceding} \\ \text{month's} \\ \text{sales} \end{array} \right) + 30\% \left(\begin{array}{c} \text{Second} \\ \text{preceding} \\ \text{month's sales} \end{array} \right)$$

Cash outflows are similar, but instead of collecting on sales and receivables, we are paying expenses and paying on our accounts payable:

Cash outflows

$$= 20\% \underbrace{\left(\begin{array}{c} \text{This} \\ \text{month's} \\ \text{purchases} \end{array} \right)}_{\text{Payments on purchases}} + 80\% \underbrace{\left(\begin{array}{c} \text{Last} \\ \text{month's} \\ \text{purchases} \end{array} \right)}_{\text{Payments on purchases}} + 5\% \underbrace{\left(\begin{array}{c} \text{This} \\ \text{month's} \\ \text{sales} \end{array} \right)}_{\text{Wages}} + 10\% \underbrace{\left(\begin{array}{c} \text{This} \\ \text{month's} \\ \text{sales} \end{array} \right)}_{\text{Other expenses}}$$

Purchases are determined by projected sales, so we can rewrite this as:

$$\text{Cash outflows} = 20\% \left(\begin{array}{c} \text{Sales} \\ \text{forecasted} \\ \text{two months} \\ \text{out} \end{array} \right) + 80\% \left(\begin{array}{c} \text{Next} \\ \text{month's} \\ \text{sales} \end{array} \right) + 15\% \left(\begin{array}{c} \text{This} \\ \text{month's} \\ \text{sales} \end{array} \right)$$

The cash inflows and outflows from operations are therefore dependent on the forecast of sales in future periods. By changing forecasted sales, the cash inflows and outflows change as well.

The CFO could continue modeling the relations expressed in the cash budget and pro forma financial statements until all the relationships are represented. Once this is done, the CFO has created a financial model of the firm. By playing *what if* with the model—changing one item and observing what happens to the rest—the CFO can see the consequences of different actions.

Building the financial model forces the CFO to think through the relationships and consequences of investment and financing decisions. Much of the computation in financial modeling can be accomplished using computers and spreadsheet programs.

The task of modeling financial relationships is made easier by computer programs. These programs reduce the modeling effort because they enable the user to program a financial model using understandable phrases instead of programming code.

PERFORMANCE EVALUATION

Planning and forecasting are important, but without some type of performance evaluation, the execution of a strategy and the accuracy of forecasting cannot be addressed. There are many performance evaluation measures

and systems available to the CFO. We will address two of these, economic value added and the balanced scorecard, to provide examples of how these may assist the CFO in assessing performance.

Economic Value Added

Arising from the need for better methods of evaluating performance, several consulting companies advocate performance evaluation methods that are applied to evaluate a company's performance as a whole and to evaluate specific managers' performances. These methods are, in some cases, supplanting traditional methods of measuring performance, such as the return on assets discussed in other chapters of this book. As a class, these measures are often referred to as *value-based metrics* or *economic value added measures*. There is a cacophony of acronyms to accompany these measures, including *economic value added (EVA®)*, *market value added (MVA)*, *cash flow return on investment (CFROI)*, *shareholder value added (SVA)*, *cash value added (CVA)*, and *refined economic value added (REVA)*.³

A company's management creates value when decisions provide benefits that exceed the costs. These benefits may be received in the near or distant future. The costs include both the direct cost of the investment as well as the less obvious cost, the cost of capital. The *cost of capital*, a topic we covered in Chapter 2, is the explicit and implicit costs associated with using investors' funds. The attention to the cost of capital sets the value-based metrics apart from traditional measures of performance such as the return on investment.⁴

The most prominent of the techniques to evaluate a company's performance are the value-added measures of *economic profit*⁵ and *market value-added (MVA)*.⁶ These measures have links to our fundamental valuation tech-

³ For a further discussion of these measures, see Frank J. Fabozzi and James L. Grant (eds.), *Value Based Metrics: Foundations and Practice* (Hoboken, NJ: John Wiley & Sons, 2000).

⁴ We discuss these traditional measures in Chapter 9.

⁵ A particular calculation of economic profit, promoted by the consultant firm of Stern Stewart, is economic value-added (EVA®). A detailed description of the value-added methods can be found in G. Bennett Stewart III, *The Quest for Value* (New York: Harper Collins, 1991).

⁶ Another prominent valuation approach is the discounted cash flow approach, advocated by McKinsey and Co. This approach involves forecasting future periods' free cash flows, forecasting a company's continuing value at the end of the forecast period, and discounting the future free cash flows and the continuing value at the company's weighted average cost of capital. Because this approach involves valuation based on forecasts, it is not a suitable device for evaluating performance, though it is useful in setting performance targets. See Tom Copeland, Tim Koller, and Jack Murrin, *Valuation: Measuring and Managing the Value of Companies*, 2nd ed. (New York: John Wiley & Sons, 1994), p. 116.

niques. Value-added measures are based on the same valuation principles as the net present value (NPV) capital budgeting technique described in Chapter 15. Keep in mind that value is not created out of thin air, but rather from a company's strategy that exploits its comparative or competitive advantage.

Whereas the NPV for a specific investment project is the estimate of change in the value of equity if the company invests in the project, an economic value added is an estimate of the change in the value of the company. Further, whereas NPV is forward looking, assisting management in making decisions dealing with the use of capital in the future, measuring a period's performance, value-added measures focus on the decisions that have been made during a period and the cost of capital that supported those investment decisions to help the CFO gauge how well the company has performed.

There are a number of value-added measures available. The most commonly used measures are economic profit and market value added.

Economic Profit/Economic Value Added

Economic value added, also referred to as *economic profit*, is the difference between operating profits and the cost of capital, where the cost of capital is expressed in dollar terms. The application to an entire company involves, essentially, calculating the NPV of all investment projects, both those involving existing assets (that is, past investment decisions) and those projected.

Although the application of economic value added is relatively new in the measurement of performance, the concept of economic profit is not new—it was first noted by Alfred Marshall in the nineteenth century.⁷ What this recent emphasis on economic profit has done is focus attention away from accounting profit and toward economic profit.

Key elements of estimating economic value added are:

- The calculation of the company's operating profit from financial statement data, making adjustments to accounting profit to better reflect a company's results for a period.
- The calculation of the company's cost of capital.
- The comparison of operating profit with the cost of capital.

The difference between the operating profit and the cost of capital is the estimate of the company's economic profit, or economic value added.

The cost of capital is the rate of return required by the suppliers of capital to the company. For a business that finances its operations or investments using both debt and equity, the cost of capital includes not only the

⁷ Alfred Marshall, *Principles of Economics: Volume 1* (New York: Macmillan, 1890), p. 142.

explicit interest on the debt, but also the implicit minimum return that owners require.⁸ This minimum return to owners is necessary so that owners keep their investment capital in the company.

Even advocates of economic profit do not prescribe a particular formula for calculating economic profit. Economic profit has ambiguous elements, most notably the adjustments to operating income and the cost of capital.⁹ Conceivably, two consultants could calculate economic profit, yet draw different conclusions regarding companies' relative performance.

Market Value Added

A measure closely related to economic profit is *market value added*. Market value added is the difference between the company's market value and its capital. Essentially, market value added is a measure of what the company's management has been able to do with a given level of resources (the invested capital): Market value added is the difference between the market value of the firm (that is, debt and equity), less the capital invested. Like economic profit, market value added is in terms of dollars and the goal of the company is to increase added value.

The key elements of market value added are:

- The calculation of the market value of capital.
- The calculation of the capital invested.
- The comparison of the market value of capital with the capital invested.

The difference between the market value of capital and the amount of capital invested is the market value added. The primary distinction between economic value added and market value added is that the latter incorporates market data in the calculation.

Balanced Scorecard

The traditional measures of a company's performance are generally historical, financial measures. With the popularity of economic value added and

⁸ The cost of capital is discussed in Chapter 2. There are many ambiguities regarding the measurement of the cost of capital (e.g., in determining the best model for the estimate of the cost of equity).

⁹ This is not the fault of economic profit, per se, but rather the starting point of the calculations: reported financial statements prepared according to generally accepted accounting principles. The calculation of net operating income after taxes (NOPAT) requires that each company be treated as an individual case. The adjustments to arrive at operating profits after taxes are different for each company and there may be over 150 adjustments applied.

market value measures, many companies began to adopt forward-looking financial measures. Taking a step further, many companies are adopting the concept of a balanced scorecard. A *balanced scorecard* is a management tool used to:

- Help put a company's strategic plan into action.
- Use measurement devices to evaluate performance relative to the strategic plan.
- Provide feedback mechanisms to allow for continuous improvement toward the strategic goals.

Robert Kaplan and David Norton developed the concept of a balanced scorecard to address the need of companies to *balance* the needs of customers, financial needs, internal management needs, and the needs for innovation and learning within the enterprise.¹⁰ They contend that single metrics do not adequately address the strategic objectives of a company; rather, multiple measures—both lagging and leading indicators—should be used to meet a company's strategic goals. These measures, referred to as key performance indicators, include short-term and long-term measures, financial and nonfinancial measures, and historical and leading measures. The balanced scorecard, therefore, goes beyond the traditional financial measures of the rate of return and profitability to capture other dimensions of a company's performance and use this information to help attain the company's strategic goals.

The Process

The balanced scorecard is really a process of determining the company's strategy, identifying measures to evaluate whether the company is meeting its short-term and long-term goals, setting targets, and then providing feedback from these measures. This process is illustrated in Figure 6.5. The actual balanced scorecard does not prescribe the measures to use, but rather specifies the dimensions of the company that should be considered in the system.

The Measures

The developers of the balanced scorecard argue that measures and metrics used to evaluate different business units and the company should represent different dimensions of performance, including financial performance,

¹⁰ Robert S. Kaplan and David P. Norton, *The Balanced Scorecard* (Boston: Harvard Business School Press, 1996), and Robert S. Kaplan and David P. Norton, *The Strategy-Focused Organization* (Boston: Harvard Business School Press, 2001).

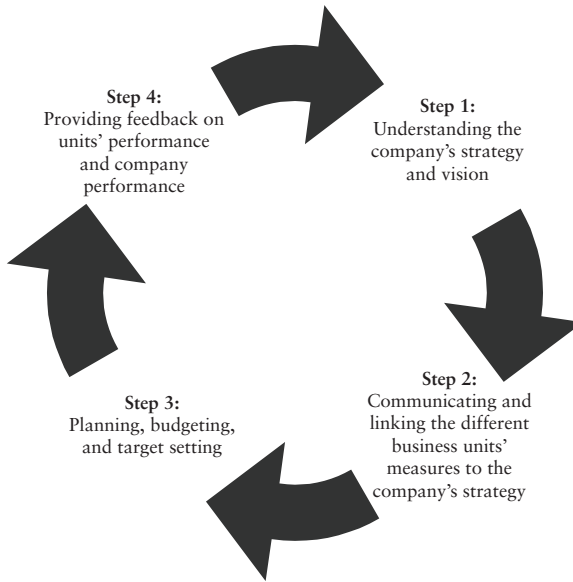
FIGURE 6.5 The Balanced Scorecard Process

customer relations, internal business processes, and organizational learning and growth. These dimensions are shown in Figure 6.6. However, no specific measures are prescribed; rather, the choice of measures should be tailored to the company's individual situation. The basic idea, however, is to select the *key performance indicators (KPIs)* that capture the four dimensions.

Within each of these dimensions, there may be any number of different measures. These measures are generally tailored to the specific business and should be consistent with the company's or unit's goals. We provide a number of possible metrics within each of these dimensions in Table 6.6.

How Do Companies Use the Balanced Scorecard?

The idea of using metrics to gauge a company or unit's performance is not new. What the balanced scorecard concept does is remind companies to evaluate themselves and their path to their strategic goals by including the different dimensions of performance, hence providing a more comprehensive look at the company.¹¹

¹¹ The balanced scorecard is consistent with a program that measures performance of strategic initiatives, required of all U.S. federal agencies (Government Performance and Results Act of 1993).

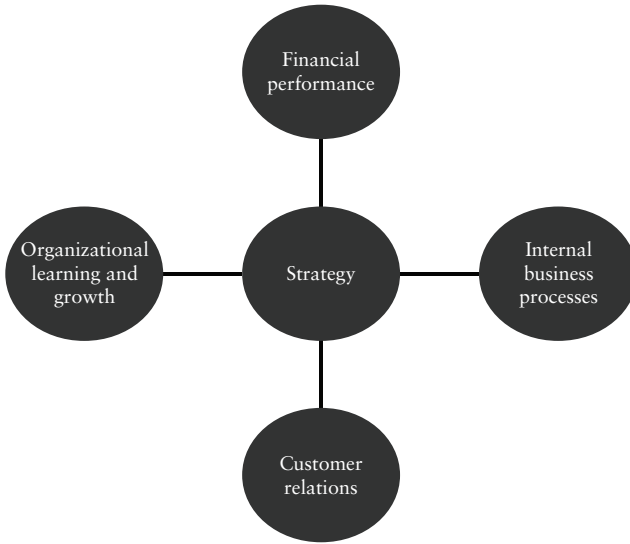
FIGURE 6.6 Relation between Strategy and Dimensions of Performance

This comprehensive look, however, does not come with a ready-equipped list of key measures or drivers. Nor does the balanced scorecard come with a system of examining these measures, which may quickly turn into a case of too much information. One estimate is that on average a company's management may be faced with examining 83 financial and 49 internal business-process metrics.¹² Limiting the number of measures to key drivers is preferred, but this is not necessarily the way in which this concept has been applied in practice.

Aside from the wealth of metrics available and used, the development of a balanced scorecard requires balancing. Yet, in practice, there are generally a greater proportion of financial measures relative to the other dimensions. This is likely due to the traditional use of financial measures in gauging performance, along with the ease of obtaining or calculating these measures. However, most of the financial measures used by companies are historical measures that do not provide the richness that the scorecard system requires to address the company's strategy.

The purpose behind the balanced scorecard approach is to help companies measure and manage their performance with respect to the company's strategic goals. As with many methods that seek to change the way compa-

¹² This is based on research by The Hackett Group, as described in Janet Kersner, "Swamped," *CFO*, November 16, 2004.

TABLE 6.6 Possible Performance Indicators in the Four Suggested Dimensions

| | |
|--|---|
| Financial performance | Customer relations |
| <ul style="list-style-type: none"> • Return on investment • Net profit margin • Economic value added • Market value added • Growth rate of revenues | <ul style="list-style-type: none"> • Customer profitability • Repeat customers • Customer surveys • Number of customer complaints • On-time delivery • Service response times |
| Internal business processes | Organizational learning and growth |
| <ul style="list-style-type: none"> • Dealer quality • Process cost • Number of units requiring reworking • Length of operating cycle • Volume of goods shipped • Optimal asset utilization | <ul style="list-style-type: none"> • Employee motivation • Employee empowerment • Information systems capabilities • Employee capabilities • Number of employee suggestions • Hours spent on training employees |

nies manage themselves, the success of the method depends on its support throughout the company and its implementation. Whereas some companies' managers believe that the scorecard helps the company work toward its strategic goals, others do not feel that approach is helpful.¹³ The evidence regarding whether companies using the balanced scorecard outperform firms that do not use such an approach is mixed.¹⁴

Scorecard for the Balanced Scorecard

According to its advocates, a balanced scorecard does the following for a company:

- The balanced scorecard encourages looking beyond historical financial measures to look at measures that permeate throughout the company and its operations.

¹³ See, for example, the survey information provided by Nomura Research Institute as reported in Toru Morisawa and Hiroshi Kurosaki, "Using the Balanced Scorecard in Reforming Corporate Management Systems," NRI Papers no. 71, December 1, 2003.

¹⁴ One study finds that balanced scorecard firms outperformed firms that did not use the balanced scorecard. See Stan Davis and Tom Albright, "An Investigation of the Effect of Balanced Scorecard Implementation on Financial Performance," *Management Accounting Research* 15 (1994), pp. 135–153. Contrary evidence is found in Christopher D. Ittner, David F. Larcker, and Taylor Randall, "Performance Implications of Strategic Performance Measurement in Financial Services Firms," *Accounting, Organizations and Society* 28 (2003), pp. 715–741.

- The balanced scorecard approach requires the flow of information both down-line—providing goals, measures, and schedules to different parts of the organization—and up-line—providing information and measures upward in the organization to allow evaluation of progress toward strategic initiatives.
- The balanced scorecard provides a framework for feedback for continuous improvement.
- The balanced scorecard encourages a company's management to keep the strategic goals in mind in both the choice of measures and use of any feedback from those measures.

Here is what the balanced scorecard cannot do for a company:

- The balanced scorecard does not detail what measures or how many a company should use, only the broad classification of such measures.
- The balanced scorecard does not establish the precise feedback mechanism, only that a company should develop such a mechanism to allow for continuous improvement.

STRATEGY AND VALUE CREATION

Role of the CFO

The CFO is in a good position to link the corporate strategy with value creation. Most surveys indicate that CFOs feel that their focus is shifting from historical assessment of performance to forward-looking tasks such as the development of strategy and decision making. CFOs not only participate in the development of a company's strategy, but in many cases the CFO is also charged with executing the strategy and measuring the company's progress toward the strategic goals.¹⁵ The CFO role has expanded from the traditional functions—controller, financial reporting, compliance and support—to include serving the company's strategy through financial decision-making. This expansion has broadened the role from a service function to an activist function.¹⁶ According to a report prepared by CFO Research Services and Booz Allen Hamilton, April 2005, p. 15:

Activism—again, defined as finance in a role beyond controllership and decision support—occurs more often among survey respon-

¹⁵ "Different Paths to One Truth: Finance Brings Value Discipline to Strategy Execution," report prepared by CFO Research Services in collaboration with Deloitte Consulting, LLP, March 2006.

¹⁶ "The Activist CFO—Alignment with Strategy, Not Just with the Business," report prepared by CFO Research Services and Booz Allen Hamilton, 2005.

dents who say their finance teams have become more closely engaged with the board of directors in the last two years.

This survey, however, indicates that those companies with closer relations with the board of directors are also firms that have greater pressure from analysts, high turnover in top management, and a need to change the company's operating model—in other words, those companies under the microscope of the business community.

It is interesting that surveys suggest an inconsistency in the CFO's role in a company's strategy and value creation: The majority of CFOs feel that strategy is their top priority, yet they also feel that this is not the perception of the CFO's role among other functions within the company (p. 9):¹⁷

... found that 60% of the CFOs surveyed cite their role in the development/formulation of corporate strategy as a priority. Yet only 25% say the rest of the organization views finance as a value added function to be consulted on all important decisions.

A 2005 survey, by Financial Executives International Canada, found that CFOs are directly accountable for financial analysis (93%), financial risk management (92.3%), forecasting and projections (87.3%), business and financial systems and reporting (82.4%), and financing and capital structure changes (79.6%).¹⁸ In terms of functions in which CFOs are closely involved, the top three functions are involvement in the operational risk management (70.4%), writing some or all of the strategic plan (69%), and strategic and business planning (59.9%). The results of this survey illustrate the breadth of the CFOs responsibility.

Sources of Value Creation

A company's strategy is a path to create value. But value cannot be created out of thin air. Value creation—that is, generating economic profit—requires identifying comparative and competitive advantages and developing a strategy that exploits these advantages.

¹⁷ Mark L. Frigo, "Strategy, Value Creation, and the CFO," *Strategic Finance*, January 2003. The study is based on the survey by CFO Research Services and Cap Gemini Ernst & Young, "CFOs: Driving Finance Transformation for the 21st Century," 2002.

¹⁸ "The Role of the CFO Today and Beyond," Financial Executives International Canada (FEI Canada) Research Studies, 2005.

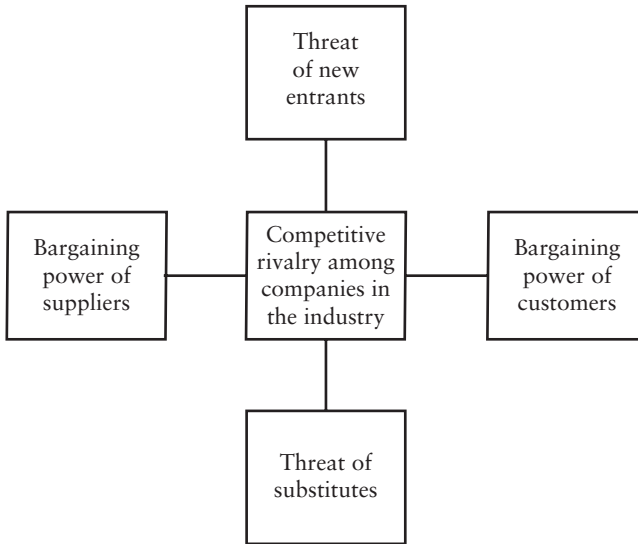
FIGURE 6.7 Porter's Five Forces

One way to look at these advantages is to use the framework introduced by Michael Porter.¹⁹ He analyzed competitive structure of industries and identified five competitive forces. These forces capture an industry's competitive rivalry, as illustrated in Figure 6.7:

- The bargaining power of suppliers.
- The threat of new entrants.
- The threat of substitute products.
- The bargaining power of buyers.
- The degree of rivalry.

More specifically,

- The bargaining power of suppliers is a force related to the providers of inputs—both goods and services. Suppliers' bargaining power is greater when the market in which they operate is dominated by a few large companies, there are no substitutes for the input, the cost of switching inputs is high, the buyers are fragmented with little buying power, and the suppliers may integrate forward to capture higher prices and margins.

¹⁹ Michael Porter, *Competitive Strategy: Techniques for Analyzing Industries and Competitors* (New York: Simon & Schuster, 1998).

- The bargaining power of customers is high when they purchase large quantities of goods or services, the buyers are concentrated, the suppliers have high fixed costs, and there are ready substitutes or the buyer could produce the good or service itself.
- The threat of new entrants is high when there are few barriers to entry. A barrier to entry is an impediment such as economies of scale, high initial startup costs, cost advantages due to experience of existing participants, loyalty among customers, protections such as patents, licenses, or copyrights, or regulatory or government action that limits entrants into the industry.
- The threat of substitutes is high when there is little brand loyalty among customers, there are no close customer relations, there are low costs to switching goods or services, and there are substitutes that are lower-priced.
- The competitive rivalry among existing members of the industry is affected by the number and relative size of the companies in the industry, the strategies of the companies, the differentiation among products, and the growth of the sales in the industry.

Porter's forces are, basically, an elaboration of the theories of economics that tell us how a company creates economic profit. Though Porter's forces may seem oversimplistic in a dynamic economy, they provide a starting point for analysis of a company's ability to add value. Porter argues that an individual company may create a competitive advantage through relative cost, differentiation, and relative prices. The CFO, in evaluating a company's current and future performance, can use these forces and strategies to identify the company's sources of economic profit.

The CFO should never ignore the basic economics that lie behind value creation. If a company has a unique advantage, this can lead to value creation. If the advantage is one that can be replicated easily by others, this advantage—and hence any value creation related to it—may erode quickly. The herding behavior of companies, seeking to mimic the strategies of the better-performing companies, may result in the erosion of value from that strategy.²⁰ This herding behavior therefore requires that strategic planning be dynamic and that feedback from performance evaluation is important in this planning process. Therefore, strategic planning should be a continual process that requires setting strategic objectives, developing the strategy, periodically measuring progress toward those goals, and then reevaluating the strategic objectives and strategy.

²⁰ See, for example, the cases discussed in “Best Practice Doesn't Equal Best Strategy,” *The McKinsey Quarterly*, McKinsey & Co., February 24, 2004.

BOTTOM LINE

- The goal of the CFO is to maximize shareholder wealth. As with any goal, it requires a strategy.
- As part of its strategy, the firm needs to plan the sources and uses of funds. The investment strategy is the plan of what investment opportunities are needed to meet the firm's goals. The financing strategy is the plan of where the firm is going to get the funds to make these investments.
- Financial planning is where decisions, actions, and goals are brought together with forecasts about the firm's sales.
- In financial planning we need to know what sales will be to determine what cash flows will be. We can forecast sales using regression analysis, market surveys, or management forecasts.
- The cash budget is used to coordinate the investment decisions—which often require cash outlays—with the financing decisions—where the cash is coming from.
- Pro forma financial statements can be generated using the percent of sales method or analyzing accounts based on the cash budget. Whereas the percent of sales method is simpler, the analysis of accounts gives the financial manager a better idea of the cash flows of the firm and their relation to the financial statements.
- Long-term financial planning is less detailed than the operational budgets, but not less important. Long-term planning helps keep financial managers focused on the objective of the firm and the strategy to achieve it.
- Financial modeling is a useful tool in looking at the array of relationships that exist in financial planning. It enables managers to examine the consequences of their decisions.
- In assessing progress toward strategic goals, the CFO can use measures such as economic value added and the balanced scorecard.
- Understanding value creation and its relation to the strategic plan requires an understanding of the sources of value creation.
- In most companies, the CFO plays an important role in the strategic planning process.

Basics of Corporate Taxes and Tax Risk Management

AGENDA

- Item 1* Discuss the main types of taxes.
- Item 2* Explain what tax management is and how it has changed since the 1990s.
- Item 3* Identify the role of the CFO in tax management.
- Item 4* Identify the factors that had a significant impact on tax directors in assessing tax risk.
- Item 5* Explain what tax risk management is.
- Item 6* Discuss the different types of tax risk and the types of events that give rise to them.
- Item 7* Understand the basics of the U.S. federal income tax code as they pertain to corporate taxes: marginal tax rates, tax treatment of interest expense and dividends paid, dividends-received deduction, depreciation for tax purposes, and net operating losses.
- Item 8* Explain differences in the taxation of corporations in non-U.S. countries.
- Item 9* Understand the issues of thin capitalization and transfer pricing associated with corporate taxation throughout the world.

Taxes are a significant cost in doing business and have a far-reaching impact on many corporate decisions—strategy, financing, capital budgeting, and corporate acquisitions/joint ventures. Following are the main kinds of taxes paid by a corporation in the United States:

- *Income taxes:* Taxes specifically levied on the basis of income.
- *Employment taxes:* Taxes that are based on income, but specifically on wage and salary income. In the United States, employment taxes are paid by the employee and the employer.
- *Excise taxes:* Taxes on certain commodities, such as alcoholic beverages, tobacco products, telephone service, and gasoline.

- *Import and export taxes:* Also known as tariffs, these taxes are based on trade with other countries.

A multinational corporation headquartered in the United States faces domestic taxes, state and local taxes, and taxes of countries where the firm operates or sells goods and/or provides services. The tax laws are so complex that the CFO cannot be expected to know the nuances of the U.S. tax code, state and local tax codes, and the tax code of the relevant non-U.S. countries where tax returns must be filed. For the purpose of advising the CFO on tax matters, corporations have a tax department and within the tax department there are specialists dealing with the different types of taxes the corporation must pay. The head of the tax department usually carries the title *tax director* or *corporate tax director*. While in some organizations the tax director reports to the CEO and the board of directors, typically the tax director will report to the CFO.¹

With federal, state, local, and national governments becoming increasingly aggressive in seeking to realize their fair share of corporate profits and seeking new sources of revenue, the impact of taxes on corporate profitability will become even more significant in the future. This concern has given rise to a risk referred to as *tax risk*. This is the risk that a corporation will incur additional tax liabilities that are substantial due to a tax audit by a tax authority, domestic or foreign. This is highlighted by the settlement of GlaxoSmithKline with the U.S. tax authorities wherein the firm agreed to pay in excess of \$5 billion in taxes resulting from an income adjustment due to the highly profitable ulcer drug Zantac. The issue involved transfer pricing and we discuss this further in Chapter 13. Moreover, in late 2006, another drug company, Merck & Co., announced that there was a potential tax liability of \$5.58 billion arising from several disputes. The tax authorities involved were the United States and Canada and one of the four disputes involved transfer pricing.

In this chapter, we explain some basic principles and concepts regarding taxes and tax risk management practices with which the CFO should be familiar. Our perspective will be that of a CFO of a U.S. corporation and so we therefore focus on U.S. tax law. More specifically, we focus on corporate income taxes at the federal level. However, any of the other types of taxes

¹ This is the finding of a survey by the accounting firm of Ernst & Young as reported in *Tax Risk Management: The Evolving Role of Tax Directors*. The survey was a telephone-based survey conducted throughout 2004 with more than 350 tax directors in some of the largest companies in 11 key jurisdictions around the world. Slightly less than half of the participants were from North America. The purpose of the survey was to provide “insights to help tax directors and corporate executives better understand the changing scope of the tax function, the risk of tax risk management and how companies are responding” p. 4.

listed above may have a strong influence on the cash flows of industries or firms. For example, excise taxes and import and export taxes will influence the demand for a firm's products and therefore the firm's cash flows. We begin with a general discussion of tax management and tax risk that applies to a corporation regardless of where it is headquartered.

TAX MANAGEMENT

Prior to the 1990s, the focus of corporate tax management (i.e., the tax function) was on the cost of doing business. As a result, tax management had as its principal role reducing costs and ensuring that the corporation was in compliance with the tax laws established by tax authorities wherever the corporation engaged in business. The tax director would typically deal with tax issues directly with the tax authorities; however, when disputes involving significant amounts that could not be resolved with tax authorities arose, the CFO oversaw the litigation process. Typically tax management was performed with little oversight and interaction from other functional units within the corporation.² The traditional measure for evaluating the performance of the tax director was the corporation's effective tax rate.

Tax management today is quite different. The focus today on tax risk (which we describe below) has resulted in tax management being integrated into the corporation's risk management system and hence tax management is now described as *tax risk management*. As stated by Ernst & Young:

Tax risk management requires tax directors to balance their traditional roles of managing costs and creating shareholder value with increased awareness of risk management issues. It demands that close attention be paid to the overall financial performance and governance of a company, while maintaining a focus on specific activities related to the accounting, reporting, internal controls, and structuring of its tax affairs.

In addition, tax risk management requires close monitoring of the new and evolving relationship between the company's tax affairs and its corporate reputation...³

The performance of tax directors is now being evaluated just like other business units in the firm with measures that go way beyond the corpora-

² In a 2004 survey by KPMG of tax departments, only 14% of the companies had board-approved objectives and one-third of companies had no written objectives at all. See "Tax in the Boardroom," KPMG discussion paper, 2004.

³ *Tax Risk Management: The Evolving Role of Tax Directors*, p. 5.

tion's effective tax rate. Basically, tax departments are being evaluated in terms of their contribution to the corporation's performance rather than being viewed as a corporate cost center. A 2004 survey study of tax directors by Ernst & Young found that the performance measure criteria for evaluating tax directors are (the percentage in parentheses indicates the percentage of directors responding that it was one of the criteria):

- Success in dealing with tax authorities (81%)
- Tax risk management (75%)
- Timeliness of compliance (64%)
- Cash flow impact (62%)
- Effective tax rate (48%)
- Other (32%)

Notice that other criteria are now more important in evaluating tax directors compared to what was done prior to the 1990s, which looked at primarily the effective tax rate and cash flow impact. Now we see that tax management is being integrated into a corporation's overall risk management system and tax directors are evaluated in terms of more than just traditional performance measures such as effective tax rate and cash flow impact.

Not only do executive management and the audit committee of the board provide oversight for tax management, but corporations have established internal oversight groups to get involved in tax policies and procedures. Who has final responsibility for approving tax policies and procedures? In the Ernst & Young survey, about two-thirds of the tax directors in the survey responded that the CFO had that responsibility and one-third responded that either the CEO or the board had that responsibility.

Figure 7.1 summarizes tax risk management today.

In a 2006 survey by KPMG, tax executives indicated that timely reporting and tax compliance are the functions that absorb the most time by tax departments.⁴ The Sarbanes-Oxley Act of 2002, specifically Section 404 dealing with internal control, has put the tax department in the sights of the board of directors and the audit committee.

TAX RISK

The most frequent external factors that have a significant impact on tax directors assessing their tax risks, according to the Ernst & Young survey, are (1) changes in the tax laws, (2) changes in the interpretation of tax laws, and (3) other regulatory changes. CFOs and the board must understand the tax risk in order to provide guidance to the tax director as to how much risk to

⁴ 2006 Tax Department Survey, KPMG Survey.

FIGURE 7.1 Increasing Expectations of the Tax Function

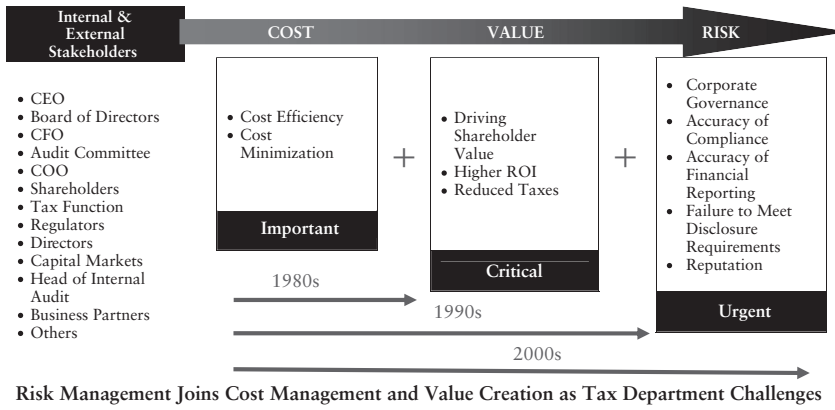

Source: Ernst & Young, *Tax Risk Management: The Evolving Role of Tax Directors*, p. 5. Reprinted with permission.

take on. This is because tax risk management is not about minimizing risk but deciding on the amount of risk that is acceptable. The tax risk management policy by a corporation will determine:

- The value added that can be achieved by taking risks.
- The cost reduction that can be attained by reducing risks.
- The corporate resources required to manage both the upside opportunities and the downside risks.

PricewaterhouseCoopers (PWC) suggests seven main areas of tax risk.⁵ These broad areas of tax risk are classified into *specific risk areas* and *general risk areas*. The specific risk areas include:

- Transactional risk
- Operational risk
- Compliance risk
- Financial accounting risk

The general risk areas include:

- Portfolio risk
- Management risk
- Reputational risk

⁵ Tony Elgood, Ian Paroissien, and Larry Quimby, *Tax Risk Management* (PricewaterhouseCoopers, 2004).

TABLE 7.1 Types of Tax Risk and Events Giving Rise to Them

| Type | Typical Events Giving Rise to Tax Risk |
|----------------------|---|
| Transactional | Acquisitions Disposals Mergers Financing transactions Tax-driven cross-border transactions Internal reorganisations |
| Operational | New business ventures New operating models Operating in new locations New operating structures (e.g., JVs/partnerships) Impact of technological developments (e.g., Internet trading) |
| Compliance | Lack of proper management Weak accounting records or controls Data integrity issues Insufficient resources Systems changes Legislative changes Revenue investigations Specific local in-country customs, approaches, and focuses in compliance |
| Financial accounting | Changes in legislation Changes in accounting systems Changes in accounting policies and GAAP |
| Portfolio | A combination of any of these events |
| Management | Changes in personnel—both in tax and in the business Experienced tax people leaving—and information being in their heads and not properly documented New/inexperienced resources |
| Reputational | Revenue authority raid/investigation Press comment Court hearings/legal actions Political developments |

Source: Tony Elgood, Ian Paroissien, and Larry Quimby, *Tax Risk Management* (PricewaterhouseCoopers, 2004), p. 35.

Copyright PricewaterhouseCoopers LLP. Not for further use or distribution without the permission of PricewaterhouseCoopers LLP.

We discuss each of these risks below. Table 7.1 shows for each type of risk the typical events that give rise to them.

Transactional Risk

Every transaction made by a corporation involves different degrees of uncertainty as to how the relevant tax law will apply and uncertainty arising from specific judgment calls. *Transactional risk* is the corporation's exposure to specific transactions that it undertakes. Routine transactions have low transactional risk. The more complex the transaction, the greater the transactional risk. This is because complex transactions are the focus of tax authorities throughout the world. One of the major reasons why transactional risks arise is the failure to properly document and implement a transaction. In disputes with tax authorities, failure to do so is likely to result in an unfavorable ruling.

The existence of transactional risk has given rise to tax insurance, which are policies bought to insure against an adverse tax ruling on a transaction. Though companies may seek out private letter rulings (PLRs) from the Internal Revenue Service regarding the tax treatment of a transaction, there is no guarantee that the IRS will issue such a ruling. Hence, the company is exposed to the risk that the tax liability on a transaction is greater than expected. Tax insurance protects the company in the event of a greater tax burden.⁶

Operational Risk

There is the risk that in applying the tax laws and regulations and making other routine decisions, errors are made. This risk is called *operational risk*. A good example is the use of transfer prices to determine the income in different countries in which a firm operates or sells products. The use of an unacceptable method in a country will result in adverse tax consequences. (We'll describe the transfer pricing issue later in this chapter and in more detail in Chapter 13.) Another example of operational risk is the inadvertent creation of a taxable presence in a state or a country during the normal course of business operations. Operational risk can be reduced by more effective communication between operating units and the tax department.

Compliance Risk

There is a risk associated with the process adopted by the corporation for preparing, completing, and reviewing tax returns and then responding, if necessary, to enquiries from tax authorities that may arise after the filing. This risk is called *compliance risk* and is more specifically described by PWC as being:

⁶ For examples, see Marie Leone, "Will Tax Insurance Catch on?" *CFO.com*, August 12, 2003.

- The integrity of the underlying accounting systems and information.
- The processes of extracting tax-sensitive information from the accounting system.
- Ensuring that the tax compliance analysis processes are based on up-to-date knowledge of the latest tax law and practice.
- The proper and efficient use of technology in the processes.

Financial Accounting Risk

The objective of the Sarbanes-Oxley Act of 2002 is to increase the quality and reliability of financial reporting. Section 404 of the act requires that corporations document and test internal controls over financial reporting. Since corporate taxes have a major impact on financial statements and the tax department is responsible for matters that have material effects on financial statements, tax directors must know their responsibilities under Section 404. Potential failure to comply with Section 404 is referred to as *financial accounting risk*. The act also has an impact on the corporation's use of tax strategies, especially those strategies that are viewed as aggressive.

Portfolio Risk

The specific risks above may individually be below some risk threshold. However, when specific risks are aggregated, the cumulative risk may be unacceptable. *Portfolio risk* with respect to tax risk is the level of risk that results from aggregating three of the specific risks (transactional risk, operational risk, and compliance risk), as well as the interaction of these three specific risks.

Management Risk

The failure to properly manage specific risks and portfolio risk is referred to as *management risk*. This risk includes both the potential additional tax liability due to failure to manage risks and the potential lost opportunities resulting from the failure to legitimately minimize taxes.

Reputational Risk

Reputational risk is difficult to manage, though it is costly in terms of litigation and the effects on the company's revenue and value.⁷ The impact

⁷ As an example of the impact of tax problems on company reputations, see Tanina Rostain, "Travails in Tax: KPMG and the Tax-Shelter Controversy," Chapter 3 in Deborah L. Rhode and Davie J. Luban (eds.), *Legal Ethics: Law Stories* (New York: Foundation Press, 2006). The Sarbanes-Oxley Act of 2002 has reduced the conflicts of interest that existed in this case in which audit clients were also clients of tax advisory and other services.

of adverse tax decisions, particularly highly publicized ones, may go well beyond the financial statements of a corporation. It may well adversely impact other business interests of the corporation. This risk is referred to as *reputational risk*. For example, a high-profile dispute between a corporation and a tax authority may result in information about the corporation's business practices becoming publicly disclosed such that it alters the view of the corporation in the eyes of its inside and outside stakeholders.

U.S. TAX LAW AND TAXATION OF CORPORATIONS

In the United States, the federal tax law is the product of all three branches of the federal government. Congress passes the tax legislation that comprises the *Internal Revenue Code (IRC)*. The *Internal Revenue Service (IRS)*, a part of the Treasury Department, interprets these laws, adds the details, and implements them. The IRS does this by providing and processing tax forms, collecting tax payments, explaining the law in its regulations, and even providing decisions regarding the law (called *rulings*) in some situations. The courts are also called on to interpret the law through specific court cases, and there is now a well-developed case law related to the IRC. Together, the IRC, IRS regulations, IRS rulings, and the case law make up federal tax law.

Federal Corporate Tax Rates

Table 7.2 shows the U.S. federal income tax rate schedules for corporations as of 2006. We can look at the schedule for a corporation to see how the income tax is computed. Each line of the schedule represents a layer of taxable income, sometimes called a "tax bracket"; the lower limit of each bracket is called its *base*. So the first line, for example, represents the taxable income layer with base \$0 and maximum taxable income of \$50,000.

Each line of the schedule also tells us the dollar amount of the tax on the base and the rate at which income above the base is taxed in that bracket. Suppose a corporation has taxable income of \$12 million. Using the tax rate schedule, we see that the tax is 15% on the first \$50,000, 25% on the next \$25,000, 34% on the next \$25,000, 39% on the next \$235,000, 34% on the next \$9,665,000, and 35% on the last \$2,000,000, or:

$$\begin{aligned}\text{Tax on } \$12,000,000 &= \$3,400,000 + 0.35(\$12,000,000 - 10,000,000) \\ &= \$3,400,000 + 700,000 = \$4,100,000\end{aligned}$$

TABLE 7.2 Federal Income Tax Rate Schedule for Corporations, 2006

| If taxable income is: | | | |
|-----------------------|------------------|-----------------|------------------------|
| over ... | but not over ... | tax is ... | of the amount over ... |
| \$0 | \$50,000 | 15% | \$0 |
| 50,000 | 75,000 | \$7,500 + 25% | 50,000 |
| 75,000 | 100,000 | 13,750 + 34% | 75,000 |
| 100,000 | 335,000 | 22,250 + 39% | 100,000 |
| 335,000 | 10,000,000 | 113,900 + 34% | 335,000 |
| 10,000,000 | 15,000,000 | 3,400,000 + 35% | 10,000,000 |
| 15,000,000 | 18,333,333 | 5,150,000 + 38% | 15,000,000 |
| 18,333,333 | — | 35% | 0 |

The *marginal tax rate* is the rate at which the next dollar of income would be taxed. It is the rate that defines the tax bracket. For a corporation with income falling between \$50,000 and \$75,000, the marginal tax rate in 2006 is 25%; for a corporation with income between \$10 million and \$15 million, the marginal tax rate is 35%.

The *average tax rate* is the ratio of the tax paid on the taxable income. So, for example, the corporation with \$12 million in taxable income paid an average tax rate of:

$$\begin{aligned} \text{Average tax rate on } \$12,000,000 &= \frac{\$4,100,000}{\$12,000,000} \\ &= 0.3417 \text{ or } 34.17\% \end{aligned}$$

Note that this average tax rate is lower than the marginal tax rate, 35%. This is true for all progressive taxes, such as the U.S. federal income tax. A *progressive tax* is one that levies a higher average tax rate on higher incomes.

The marginal and average tax rates for a range of 2006 taxable corporate incomes are graphed in Figure 7.2. It is apparent from this diagram that as corporate income increases, the average tax rate approaches the marginal rate of tax. It is also apparent that the corporate income tax is progressive. Note, however, that the corporate tax rate schedule in 2006 has a “bubble” of 39% in the \$100,000 to \$335,000 bracket, where the rate is lower in the next higher tax bracket. These bubbles appear occasionally in the tax rate schedules mainly to increase revenues, and many times they disappear from the schedules after a year or two. They usually do not change the progressive nature of the tax.

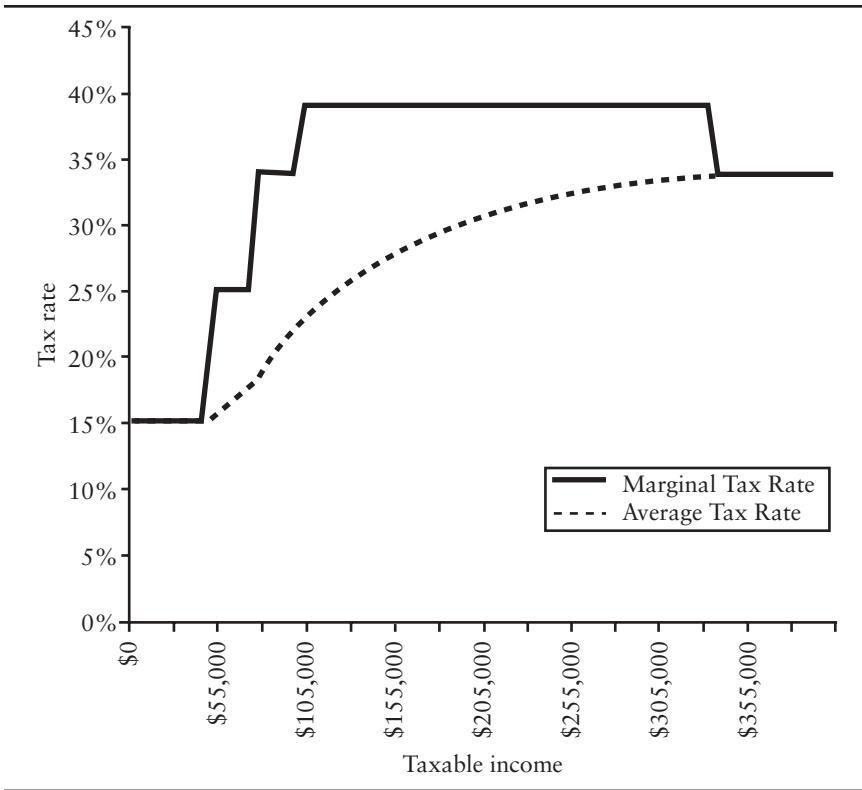
FIGURE 7.2 Marginal and Average Tax Rates from the 2006 Corporate Tax Rate Schedule

It is important to realize that taxable income is taxed at the appropriate *marginal* tax rate for each bracket, and not at the average tax rate. Therefore, when a company's investing or financing decision is likely to affect taxable income—and hence cash flow—it will do so through the *marginal* tax rate.

Corporate Taxable Income

There are many areas in which companies are permitted to use different methods of accounting for financial statements and tax purposes. These differences may arise from mandated methods of accounting for tax purposes (e.g., depreciation) or from the deductibility of certain expenses for the determination of income for one but not the other (e.g., goodwill). The

result of these differences is a timing difference between reported tax expense and actual tax expense. If the reported tax expense exceeds the actual tax expense, the difference is a *deferred tax liability* and if the reported tax expense is less than the actual tax expense, the difference is a *deferred tax asset*. The deferred tax asset or liability therefore reflects a temporary difference between expense and revenue recognition for an accounting period.

There are many potential sources of differences between income per accounting statements and taxable income. Examples of temporary sources of differences between accounting income and taxable income include the methods of recognition for accruals and reserves, depreciation deductions, and tax loss carryovers. The sources of the deferred tax liability or asset are summarized in the company's income tax note to the financial statements.

Recognizing that some temporary differences persist over time, Statement of Financial Accounting Standards No. 109 requires that deferred taxes be adjusted for the expected permanent difference in tax liability per financial statements and tax books; this adjustment is referred to as a *valuation allowance*. The result of including the valuation allowance is a deferred tax liability or asset that better reflects temporary differences between accounting and tax books.

In addition to these temporary differences, there are permanent differences between financial and tax income. For example, dividends received from other corporations are included fully in the financial income (discussed below), but are permitted to be deducted in whole or part for tax purposes, which results in a permanent difference between taxable income and accounting income. Permanent differences such as this do not affect the deferred tax accounts.

The basic calculation of a corporation's taxable income is shown in Table 7.3. To better understand how different features of the tax law affect a firm's taxes and, hence, its cash flows, we take a closer look at the dividends-received deduction, interest deduction, depreciation for tax purposes, and capital gains taxation.

Dividends-Received Deduction

Corporate income distributed to shareholders (in the form of dividends) is taxed twice—first as corporate income and then as shareholders' income—and then if the shareholder is another corporation, that income could be taxed a third time. To minimize the chance of triple (or even quadruple) taxation of the same income, the tax laws permit a *dividends-received deduction*: A corporate recipient of dividends may deduct a portion of its dividend income from its taxable income.

TABLE 7.3 Corporate Taxable Income

| |
|---------------------------------|
| Gross receipts |
| – <u>Cost of goods sold</u> |
| Gross profit |
| + Dividend income |
| + Interest income |
| + Gross rents |
| + Gross royalties |
| + Capital gain income |
| + <u>Other income</u> |
| Total income |
| – Salaries and wages |
| – Repairs and maintenance |
| – Bad debt expense |
| – Rents |
| – Taxes and licenses |
| – Interest |
| – Charitable contributions |
| – Depreciation |
| – Depletion |
| – Advertising |
| – Pension, profit-sharing plans |
| – Employee benefit programs |
| – <u>Other deductions</u> |
| Total deductions |
| Taxable income |

With respect to dividend income received by corporations, the tax law specifies deductions of either 100%, 80%, or 70%, as follows:

- Deduction of 100% of dividends received if the corporation is (1) a small business investment company operated under the Small Business Investment Act or (2) a member of an affiliated group of corporations, as in the case of a parent corporation and its wholly owned subsidiaries.

- Deduction of 80% if the dividends are received from a 20% or more owned corporation.
- Deduction of 70% if none of the conditions above applies.

The dividends-received deduction either eliminates the tax on dividend income or reduces the effective tax rate considerably. Suppose a corporation has a marginal tax rate of 34% and the dividends it receives qualify for the 70% deduction. Then the effective tax rate on that dividend income is 30% of 34%, or 10.2%.

The dividends-received deduction has implications for managing short-term investments by the corporate treasury department. When a corporation has excess funds to invest temporarily, it will look for a suitable short-term investment instrument in which to park those funds. One investment candidate is the short-term debt of the U.S. government or issued by a corporation with a high credit rating. The interest will be fully taxed by the corporation receiving the payment. An alternative investment instrument is preferred stock with a short-term maturity issued by a corporation with a high credit rating. We discussed the characteristics of preferred stock in Chapter 4; the important feature of this instrument is that it is a form of equity and therefore the dividends received by a corporation qualify for the dividends-received deduction. Hence, the preferred stock as an investment outlet for short-term funds would be a tax-advantaged investment compared to investing in short-term debt instruments.

Interest Expense Deduction

For corporations, the IRC allows interest paid on debt to be deducted in deriving taxable income. The benefit of the interest deduction is that it shields income from taxation and we refer to this benefit as the interest tax shield. Given the marginal tax rate and the dollar amount of the interest deduction, the interest tax shield is computed as:

$$\text{Interest tax shield} = (\text{Marginal tax rate}) \times (\text{Interest expense})$$

In contrast to interest expense, the dividends paid by a corporation are not deductible for the purpose of determining taxable income. The reason is that dividends paid represent a distribution of profits to the owners of the corporation. The deductibility of interest expense and the nondeductibility of dividends paid have important implications for the use of debt and equity in financing by a corporation and its cost of capital. The mix of debt and equity is referred to the firm's *capital structure* and is a topic that we covered in Chapter 2.

There is another implication of the different treatment of interest expense and dividends paid under the tax code. This has to do with the classification of a financing instrument as debt rather than equity. Some corporations have issued instruments that have the contractual provisions that can best be characterized as equity but they label these instruments “debt.” The advantage of doing so from a tax perspective is that payments made on the instrument to their owners would be treated as interest and therefore deductible. The IRS is aware of this practice and can recharacterize debt as equity and adjust taxable income accordingly.

Depreciation for Tax Purposes

For accounting purposes, a firm can select a method of depreciation based on a number of factors, including the expected rate of physical depreciation of its asset and the effect on reported income. For federal income tax purposes, however, businesses are limited by law with regard to both the depreciation method and the period of time over which an asset can be depreciated.

The current depreciation tax laws are the result of an ongoing trend to create more uniformity in depreciation methods among business taxpayers while at the same time simplifying the calculations and allowing accelerated depreciation and shorter asset lives.

Currently, the two methods of depreciation available to business taxpayers are an accelerated method and straight-line. The accelerated method, referred to as the *modified accelerated cost recovery system* (MACRS), has four features:

1. The depreciation rate used each year is either 150% or 200% of the straight-line rate (referred to as 150 declining balance (DB) and 200 DB, respectively), depending on the type of property, applied against the undepreciated cost of the asset. Since the rate is applied against a declining amount, this method is a declining balance method, but not the same declining balance method as that used for financial statement reporting purposes.
2. The salvage value of the asset is ignored; so the depreciable cost is the original cost and the asset's value is depreciated to zero.
3. The *half-year convention* is used on most property, that is, a half-year of depreciation is taken in the year the asset is acquired, no matter whether it is owned for one day or 365 days.
4. The depreciation method is switched to the straight-line method when straight-line depreciation produces a higher depreciation expense than the accelerated method.

Because the MACRS is an accelerated method, it yields greater depreciation expenses in earlier years and thus reduces taxable income and taxes relative to straight-line depreciation. However, the law allows some firms to use straight-line depreciation if they don't have the income necessary to take advantage of the faster depreciation of the MACRS. The use of MACRS for tax purposes and straight-line for financial reporting purposes, which is often the case for U.S. corporations, results in a difference in income for tax and financial accounting. This difference gives rise to deferred tax liabilities because actual taxes (calculated using MACRS depreciation) are less than reported taxes (calculated using straight-line depreciation) when MACRS results in a greater amount of depreciation, as in the earlier years of an asset's life.⁸

Tables 7.4 and 7.5 outline the depreciable life for each class of assets and the depreciation rates used for assets of each classified life, respectively. Table 7.4 shows the depreciable lives are assigned to the various classes of assets that might be used by businesses. Table 7.5 shows the depreciation rates to be applied to the asset's cost for each year in the life of each class of asset.

Notice in Table 7.5 that each asset type is depreciated over its life plus one year: There are four years of depreciation for a 3-year asset, six years of depreciation for a 5-year asset, and so on. This is because of the half-year convention: Only half a year's depreciation is used up at the start, leaving half a year's depreciation to be taken after the asset's life is over for tax purposes.

TABLE 7.4 Modified Accelerated Cost Recovery System (MACRS): Classified Lives

| | |
|------------|--|
| 3-year: | Tractor units, racehorses over two years old, special tools |
| 5-year: | Cars, light and heavy trucks, computer and peripheral equipment, semiconductor manufacturing equipment |
| 7-year: | Office furniture and fixtures, railroad property |
| 10-year: | Means of water transportation, fruit trees, nut trees |
| 15-year: | Municipal wastewater plants, depreciable land improvements, pipelines, service station buildings |
| 20-year: | Farm buildings, municipal sewers |
| 27.5-year: | Residential rental property |
| 31.5-year: | Nonresidential real property, such as elevators and escalators |
| 50-year: | Railroad grading and tunnel bores |

⁸ In Table 7.4, for example, we see that most of the deferred tax liabilities arise from the depreciation of property, plant, and equipment.

TABLE 7.5 MACRS Depreciation Rates for 3-Year, 5-Year, 7-Year, 10-Year, 15-Year, and 20-Year Classified Assets

| Year | Depreciation Rate (%) | | | | | |
|------|-----------------------|--------|--------|---------|---------|---------|
| | 3-Year | 5-Year | 7-Year | 10-Year | 15-Year | 20-Year |
| 1 | 33.33 | 20.00 | 14.29 | 10.00 | 5.00 | 3.750 |
| 2 | 44.45 | 32.00 | 24.49 | 18.00 | 9.50 | 7.219 |
| 3 | 14.81 | 19.20 | 17.49 | 14.40 | 8.55 | 6.677 |
| 4 | 7.41 | 11.52 | 12.49 | 11.52 | 7.70 | 6.177 |
| 5 | | 11.52 | 8.93 | 9.22 | 6.93 | 5.713 |
| 6 | | 5.76 | 8.92 | 7.37 | 6.23 | 5.285 |
| 7 | | | 8.93 | 6.55 | 5.90 | 4.888 |
| 8 | | | 4.46 | 6.55 | 5.90 | 4.522 |
| 9 | | | | 6.56 | 5.91 | 4.462 |
| 10 | | | | 6.55 | 5.90 | 4.461 |
| 11 | | | | 3.28 | 5.91 | 4.462 |
| 12 | | | | | 5.90 | 4.461 |
| 13 | | | | | 5.91 | 4.462 |
| 14 | | | | | 5.90 | 4.461 |
| 15 | | | | | 5.91 | 4.462 |
| 16 | | | | | 2.95 | 4.461 |
| 17 | | | | | | 4.462 |
| 18 | | | | | | 4.461 |
| 19 | | | | | | 4.462 |
| 20 | | | | | | 4.461 |
| 21 | | | | | | 2.231 |

These rates reflect depreciation calculated using the 200% (for 3-year, 5-year, 7-year, and 10-year property) or 150% (for 15-year and 20-year property) declining-balance method, with a switch to straight-line, using the half-year convention.

Let's see how depreciation expense is calculated using the information in Table 7.6. Suppose a firm buys a fleet of trucks for \$500,000. According to Table 7.4, the truck has a 5-year class life. According to Table 7.5, the first year's depreciation rate is 20%, the next year's is 32%, and so on. The results of applying these rates to the cost of the truck over six years are shown in Table 7.6. The total cost is recouped over the six years, with most of the depreciation expense taken in the earlier years.

Understanding current and expected depreciation rates is important because depreciation, while not itself a cash flow, affects a corporation's taxes and hence its cash flows. If the corporation has a depreciation expense of \$100 million and a 35% marginal tax rate, the benefit from the depreciation deduction for tax purposes is to reduce taxable income by \$100 million

TABLE 7.6 MACRS Depreciation of a Fleet of Trucks Costing \$500,000 Using MACRS Rates

| Year | Depreciation Rate | Depreciation Expense = Rate Times \$500,000 |
|-------|-------------------|---|
| 2007 | 20.00% | \$100,000 |
| 2008 | 32.00 | 160,000 |
| 2009 | 19.20 | 96,000 |
| 2010 | 11.52 | 57,600 |
| 2011 | 11.52 | 57,600 |
| 2012 | 5.76 | 28,800 |
| Total | 100.00% | \$500,000 |

and hence reduce taxes by 35% times \$100 million, or \$35 million. This reduction in taxes of \$35 million is referred to as the *depreciation tax-shield*. Over the life of an asset, the total dollar amount of depreciation is the same regardless of the rate of depreciation. However, changes in depreciation rates affect the *timing* of the depreciation tax-shield and hence their value today.

Capital Gains

The term “capital gain” is loosely used to mean an increase in the value of an asset. In the tax law a *capital gain* is defined more specifically. It is a realized gain that results when an asset is sold for more than what was paid for it. Because tax rates are progressive, taxing capital gains in one lump in one year at higher rates seems unfair, so Congress has traditionally granted special treatment—via lower effective tax rates—to capital gains.

Special treatment for capital gains has come in either of two ways: (1) an exclusion of a portion of the gain or (2) a cap on the tax rate applied to capital gains. A cap is a ceiling on the tax rate applied to capital gains and is lower than the tax rate applied to other income. In 2007, for example, the tax rate cap on capital gains was 35% for corporations.

Suppose that in 2007 the Taxit Corporation has ordinary taxable income (that is, taxable income not including capital gains) of \$50,000 and a capital gain of \$10,000. Taxit’s tax bracket is 25%, which is below Year 6’s corporate capital gains rate of 35%. So Taxit’s tax on its \$60,000 of income is:

$$\text{Tax on } \$60,000 = \$7,500 + 0.25(\$60,000 - \$50,000) = \$10,000$$

Suppose instead that Taxit has ordinary income of \$200,000 and a capital gain of \$10,000. Taxit’s tax is:

$$\begin{array}{rcl}
 \text{Tax} & = & \underbrace{\$22,250 + 0.39 (\$200,000 - 100,000)}_{\substack{\uparrow \\ \text{tax on ordinary income}}} + \underbrace{0.35 (\$10,000)}_{\substack{\uparrow \\ \text{tax on capital gain income}}} \\
 & = & \$61,250 + 3,500 \\
 & = & \$64,750
 \end{array}$$

The other way of giving special treatment to capital gains for tax purposes is via an exclusion. A capital gains exclusion excludes a portion, say 60%, of the capital gain from taxation and taxes the remainder at the ordinary tax rate. Consider Taxit Corporation's income. If 60% of its capital gain is excluded, only 60% of the \$10,000, or \$6,000 is included in taxable income.

For a depreciable asset, a part of the gain may really be the result of "over-depreciating" it (for tax purposes) during its life; that is, depreciation expenses taken over the life of the asset (which reduced taxable income and taxes) do not represent the actual amount the asset depreciated in value. So, there are provisions in the tax laws that require breaking the gain into two parts:

1. The *recapture of depreciation*, the difference between (a) the lower of the original cost or the sales price and (b) the underdepreciated portion of the asset's cost for tax purposes.
2. The capital gain, which is the sales price less the original cost.

The recapture portion of the gain is taxed at ordinary rates, and the capital gain portion is given special treatment (so effectively, it is taxed at less than ordinary rates).

Suppose Reclaim Inc. bought a depreciable asset 10 years ago for \$100,000, and its book value (cost less accumulated depreciation) for tax purposes is now \$30,000. This means that the firm has taken \$70,000 of depreciation expense over the 10 years and has reduced its taxable income by that amount. If it now sells this asset for \$125,000, it has a capital gain of \$25,000 (sale price of \$125,000 less the cost of \$100,000).

But Reclaim has also recaptured its entire depreciation expense by selling the asset. The tax code requires that recaptured depreciation be added to ordinary income and therefore taxed at the ordinary income tax rate. Reclaim would have to pay ordinary income tax on the recaptured \$70,000 of depreciation and capital gains tax on \$25,000.

| | |
|--------------------------------------|---------------|
| Original cost | \$100,000 |
| Less book value | <u>30,000</u> |
| Recapture (taxed as ordinary income) | \$70,000 |

If only part of the asset's depreciation is recaptured when it is sold, only the recaptured part is taxed, and there would be no capital gain. The recaptured portion is the difference between sales price and tax basis. For example, if Reclaim sold the asset for \$75,000, instead of \$125,000, it would have:

| | |
|--------------------------------------|---------------|
| Sales price | \$75,000 |
| Less tax basis | <u>30,000</u> |
| Recapture (taxed as ordinary income) | \$45,000 |

As you can see, taxes, depreciation, and capital gains are all mutually related. Furthermore, they all become considerations in investment decisions, which almost always deal in some way with the purchase and sale of assets, and in cash flow, which is directly affected by tax law.

Tax Credits

From time to time Congress allows business credits against calculated income tax. One such credit that has popped up now and then in the tax law is the *investment tax credit (ITC)*. The ITC may or may not exist at the time you read this chapter.

A tax credit is a direct reduction of the computed income tax. Suppose, for example, that the tax code allows an ITC of 10%. If a company invests \$100 million, say, in new machinery, it is entitled to a direct reduction in taxes based on the cost of the machinery: 10% of \$100 million, or \$10 million.

The ITC is not the only tax credit that Congress has offered businesses. At one time or another there have been energy tax credits, targeted job credits, alcohol fuel credits, disabled access credits, and more.

Tax Credit versus Tax Deduction

Deductions and credits both reduce taxes payable. A *deduction* reduces taxable income and thus indirectly reduces the tax liability. A tax *credit* is subtracted from the tax liability in the absence of the tax credit, and thus directly reduces taxes.

For example, suppose a corporation has \$100 million in taxable income without considering a potential deduction or credit and, for simplicity, assuming a flat tax rate of 40%. Table 7.7 shows the effect on the firm's taxes resulting from a \$10 million deduction compared to a \$10 million tax credit. The benefit from the deduction is \$4 million, whereas the benefit from the credit is \$10 million.

TABLE 7.7 Illustration of the Effect of a \$10 Million Tax Deduction versus a \$10 Tax Credit

| | No Deduction, No Credit | Deduction, No Credit | Credit, No Deduction |
|----------------------------------|----------------------------|-------------------------|-------------------------|
| Taxable income without deduction | \$100 | \$100 | \$100 |
| Deduction | <u>0</u> | <u>10</u> | <u>0</u> |
| Taxable income | \$100 | \$90 | \$100 |
| Tax rate | <u>0.40</u> | <u>0.40</u> | <u>0.40</u> |
| Tax before credit | \$40 | \$36 | \$40 |
| Credit | <u>0</u> | <u>0</u> | <u>10</u> |
| Tax | \$40 | \$36 | \$30 |

Net Operating Loss Carrybacks and Carryovers

A *net operating loss (NOL)* is an excess of business deductions over business gross income in a tax year. The Internal Revenue Code allows businesses to carry back a net operating loss to preceding years and to carry forward the loss to future years to reduce the taxes payable for those years. The current tax law, for example, permits NOLs of corporations to be carried back two years from the year of the loss and carried over (forward through time) 20 years.

Here's how carrybacks and carryovers work. Suppose that in 2007 a corporation has a \$100 million NOL. To simplify the calculations, let's also assume that the corporate tax rate is a flat 40% of income. Suppose further that the corporation paid taxes on income as follows in the two years prior to 2007:

| Year | Taxable Income | Taxes Paid |
|------|----------------|-------------|
| 2005 | \$10,000,000 | \$4,000,000 |
| 2004 | 50,000,000 | 20,000,000 |

To use the loss in 2007, the corporation begins by carrying it back to the earliest year (2005 in this example), applying it to reduce that year's taxable income, and then recomputing the tax. Any loss that is left over is carried to the next year (2006). The tax law allows a 2-year carryback, so the computation would look like this:

| Year | Taxable Income | Amount of Loss Applied | Refigured Taxable Income | Refigured Taxes | Refund |
|------|----------------|------------------------|--------------------------|-----------------|--------------|
| 2005 | \$10,000,000 | \$10,000,000 | \$0 | \$0 | \$4,000,000 |
| 2006 | 50,000,000 | 50,000,000 | 0 | 0 | 20,000,000 |
| | | \$60,000,000 | | | \$24,000,000 |

The corporation would then apply for a \$24 million refund of 2005 and 2006 taxes on the basis of its current year (2007) NOL. The balance of the NOL that is not applied to those two years, \$40 million, can be carried forward for 20 years.

STATE AND LOCAL TAXES

In addition to the federal income tax, individuals and corporations may also be assessed state and local income taxes. State and local tax structures are, for the most part, dependent on the federal tax system. With some exceptions and an occasional adjustment to taxable income, state and local taxes are levied as a percentage of the federal income.

State and local taxes can be significant, with rates ranging from 1% to 12%, depending on the locality in which the corporation conducts its business. For example, in fiscal year 2005, the Walt Disney Company paid federal taxes with a top rate of 35% and state taxes with an effective rate of 2.1%.⁹

NON-U.S. TAXES

Non-U.S. taxes paid by corporate entities can be classified into two types: income taxes and indirect taxes. The former includes taxes paid to the central government based on corporate income and possibly any local income taxes. Indirect taxes include real estate value-added and sales taxes, as well as miscellaneous taxes on business transactions. In this section, we provide an overview of the key corporate income tax issues that affect investing decisions and financing decisions in foreign countries.

⁹ The Walt Disney Company 2005 10-K filing, p. 105. Because state taxes are deductible for federal income tax purposes, the state tax rate reflects this benefit and, hence, is lower than the statutory state corporate tax rate. The company's effective tax rate for 2005 was also affected by audit settlements and foreign sales corporation and extraterritorial income, among other things, which reduced the effective tax rate to 31.1%.

Corporate Income Tax Rates

The basic corporate income tax imposed by central governments is a fixed percentage or an increasing percentage of the statutorily determined corporate income. The rate varies significantly from country to country.

Countries typically tax resident corporations on worldwide income regardless of whether the income is repatriated. Nonresident corporations, that is, corporations whose corporate seat and place of management are outside the country, are typically subject only to corporate taxes derived from within the country.

The range of corporate tax rates for select countries is shown in Table 7.8 as of January 1, 2006 as posted by the OECD. However, the basic tax rates shown in the second column of the table can be misleading for several reasons. First, the calculation of corporate income varies based on the types of revenues that may or may not be included as taxable and permissible deductions. Second, there may be a refund for corporate income distributed to shareholders that lowers the effective tax rate or an additional corporate tax paid on distributed income that raises the effective tax rate. Third, there may be a different tax rate based on the characteristics of the commercial entity, such as its size. Fourth, the effective tax rate may be different for undistributed income and income distributed to shareholders. Finally, the tax rate can vary for resident and nonresident business entities.

Several countries impose no tax or minimal tax rates. These countries are referred to as *tax havens*. The Cayman Islands and Bermuda are examples. Tax havens are used by some entities to avoid or reduce taxes. The use of tax havens by U.S. entities was significantly reduced by the Tax Reform Act of 1986.

A country's tax authorities withhold taxes on income derived in their country by nonresident corporations. The withholding tax rate may vary, depending on the type of income: dividends, interest, or royalties. Major trading countries often negotiate tax treaties to reduce the double taxation of corporate income.

A corporation's effective tax rate on its worldwide income therefore depends on tax treaties between its home country and all the foreign countries where it has established a nonresident corporation. Moreover, the rate also depends on whether a corporation is permitted a credit by the tax authorities in its home country against taxes paid in foreign countries. Many countries permit this credit, called a *foreign tax credit*. The limitation is usually that the tax credit paid to a foreign country may not exceed the amount that would have been paid in the home country.

TABLE 7.8 Corporate Income Tax Rate in Selected Countries, 2006¹

| Country | Central Government Corporate Income Tax Rate ² | Adjusted Central Government Corporate Income Tax Rate ³ | Sub-Central Government Corporate Income Tax Rate ⁴ | Combined Corporate Income Tax Rate ⁵ | Targete Corporate Tax Rates ⁶ |
|-----------------------------|---|--|---|---|--|
| Australia ^a | 30.0 | 30.0 | | 30.0 | Y |
| Austria | 25.0 | 25.0 | | 25.0 | N |
| Belgium ^b | 33.99 (33.0) | 33.99 | | 33.99 | Y |
| Canada | 22.1(21.0) | 22.1 | 14.0 | 36.1 | Y |
| Czech Republic | 24.0 | 24.0 | | 24.0 | Y |
| Denmark | 28.0 | 28.0 | | 28.0 | N |
| Finland | 26.0 | 26.0 | | 26.0 | N |
| France ^c | 34.43 | 34.43 | | 34.4 | Y |
| Germany ^d | 26.375 (25.0) | 21.9 | 17.01 | 38.9 | N |
| Greece | 29.0 | 29.0 | | 29.0 | n.a. |
| Hungary ^e | 16.0 | 16.0 | | 16.0 | Y |
| Iceland | 18.0 | 18.0 | | 18.0 | N |
| Ireland | 12.5 | 12.5 | | 12.5 | Y |
| Italy ^f | 33.0 | 33.0 | | 33.0 | N |
| Japan | 30.0 | 27.98 | 11.56 | 39.54 | Y |
| Korea | 25.0 | 25.0 | 2.5 | 27.5 | Y |
| Luxembourg | 22.88 (22.0) | 22.88 | 7.5 | 30.4 | Y |
| Mexico | 29.0 | 29.0 | | 29.0 | Y |
| Netherlands | 29.6 | 29.6 | | 29.6 | Y |
| New Zealand ^a | 33.0 | 33.0 | | 33.0 | N |
| Norway | 28.0 | 28.0 | | 28.0 | Y |
| Poland ^g | 19.0 | 19.0 | | 19.0 | n.a. |
| Portugal ^h | 25.0 | 25.0 | 2.5 | 27.5 | Y |
| Slovak Republic | | | | | |
| Spain | 35.0 | 35.0 | | 35.0 | Y |
| Sweden | 28.0 | 28.0 | | 28.0 | N |
| Switzerland ^b | 8.5 | 6.69 | 14.64 | 21.3 | N |
| Turkey | 30.0 | 30.0 | | 30.0 | N |
| United Kingdom ^a | 30.0 | 30.0 | 6. | 39.3 | Y |
| United States ⁱ | 35.0 | 32.7 | 6.6 | 39.3 | Y |

Key to abbreviations:

n.a.: Data not provided

TABLE 7.8 (Continued)*Explanatory notes:*

¹ This table shows 'basic' (non-targeted) central, sub-central and combined (statutory) corporate income tax rates. Where a progressive (as opposed to flat) rate structure applies, the top marginal rate is shown. Further explanatory notes may be found in the Explanatory Annex.

² This column shows the basic central government statutory (flat or top marginal) corporate income tax rate, measured gross of a deduction (if any) for sub-central tax. Where surtax applies, the statutory corporate rate exclusive of surtax is shown in round brackets ().

³ This column shows the basic central government statutory corporate income tax rate (inclusive of surtax (if any)), adjusted (if applicable) to show the net rate where the central government provides a deduction in respect of sub-central income tax.

⁴ This column shows the basic sub-central (combined state/regional and local) statutory corporate income tax rate, inclusive of sub-central surtax (if any). The rate should be the representative rate reported in Table II.3. Where a sub-central surtax applies, the statutory sub-central corporate rate exclusive of surtax is shown in round brackets ().

⁵ This column shows the basic combined central and sub-central (statutory) corporate income tax rate given by the adjusted central government rate plus the sub-central rate.

⁶ This column indicates whether targeted (non-basic) corporate tax rates exist (e.g., with targeting through a special statutory corporate tax rate applied to qualifying income, or through a special deduction determined as a percentage of qualifying income). Where a 'Y' is shown, more information can be found in Table II.2.

Country-specific footnotes:

^a For Australia, New Zealand and the UK, all with a non-calendar tax year, the rates shown are those in effect as of 1 July, 1 April and 1 April, respectively.

^b The effective CIT rate can be substantially reduced by a notional allowance for corporate equity (ACE). E.g. the effective tax rate is only half the nominal tax rate when the return on equity before tax is twice the notional interest rate (3.442% in 2006). See explanatory notes for more details.

^c The rates include a surcharge, but does not include the local business tax (Taxe professionnelle) or the turnover based solidarity tax (Contribution de Solidarité). More information on the surcharge is included as a comment.

^d The rates include the regional trade tax (Gewerbesteuer) and the surcharge.

^e The rates do not include the turnover based local business tax and the innovation tax.

^f These rates do not include the regional business tax (Imposta Regionale sulle Attività Produttive; IRAP). See explanatory notes for more details.

^g Source for the information: KPMG's Corporate Tax Rate Survey.

^h Adjusted central and sub-central tax rates are calculated by the Swiss Federal Tax Administration (see 'Quels taux effectifs et nominaux d'imposition des sociétés en Suisse pour le calcul des coins fiscaux. Le procédé de la déduction fiscale en Suisse'). Church taxes are included, but the results excluding church taxes are indicated as comments.

ⁱ The sub-central rate is a weighted average state corporate marginal income tax rate. See explanatory notes for more details.

Source: Reproduced from OECD, <http://www.oecd.org/dataoecd/26/56/33717459.xls>.

Determining Taxable Income

Varying definitions of taxable revenue and deductible expenses cause the determination of corporate profits to vary from country to country. By far, the largest variance can be attributed to the differences in the treatment of items that are deductible for tax purposes. Different methods of treating of noncash expenses such as depreciation and inventory valuation can affect the calculation of taxable income.

Two other considerations affect the determination of taxable income. Both of these matters relate to the deductibility of items that foreign tax authorities view as legitimate expenses but are incurred to minimize taxes in the foreign country. The first is the deductibility of interest expense when that expense may be viewed as excessive. The second is the inflation of expenses associated with the sale or purchase of goods and services by a nonresident company with an associated company (that is, a parent company or another subsidiary of the parent) outside the foreign country. These two factors are interest expense and transfer prices used in intercompany transactions.

Interest Expense

In most countries, the interest expense associated with borrowed funds is tax deductible. Dividends, in contrast, are treated as distributed profits and are not tax deductible.¹⁰ This difference is particularly important when a parent company provides financing to a foreign subsidiary. Interest paid by a subsidiary to its parent is deductible for the subsidiary but taxable for the parent. Dividends, in contrast, are taxable for both the subsidiary and the parent.

An increasing number of firms have employed creative financing arrangements to benefit from the tax advantage associated with debt. It can be done in two ways. First, a financing agreement can be called “debt” even though it is effectively a form of equity. For example, an instrument may be called a debt obligation but, unlike legitimate debt, it allows the “borrower” to miss periodic payments if sufficient cash flow is unavailable. Or the priority of the “creditors” can be subordinated to all other creditors and to preferred stockholders. Both of these provisions indicate that the instrument may be more appropriately classified as a form of equity rather than debt. Second, several companies have employed capital structures that predominately consist of debt. Companies that have this capital structure are referred to as *thin capitalization companies*.

In some countries, tax authorities have challenged whether some of the debt should be appropriately recharacterized as equity for tax purposes,

¹⁰ However, some countries allow the dividend-paying company to receive a tax credit for distributed profits.

thereby eliminating the deductibility of interest for the reclassified portion. The recharacterization of debt to equity may be due to the terms of the individual agreement or security regardless of the ratio of debt to equity. When a company's debt-to-equity ratio is high, tax authorities may seek to recharacterize a portion of the debt to equity for tax purposes. The Committee on Fiscal Affairs of the Organisation for Economic Co-operation and Development (OECD) addressed the issue of thin capitalization in a 1998 publication, *The OECD Report on Thin Capitalization*. The report identifies the general issues but does not provide any guidelines as to what constitutes an excessive debt-to-equity ratio. As part of the OECD 1998 report, *Harmful Tax Competition: An Emerging Global Issue*, the thin capitalization issue was revisited but again no guidelines were provided.

Tax authorities or finance ministries use other methods to attempt to curtail what they perceive to be an abuse of borrowing to benefit from interest deductibility. One way is to place an explicit restriction on the amount of interest that may be deductible. To restrict resident companies controlled by foreign entities from being thinly capitalized, some countries, requiring approval of the investments by foreign entities, do not grant that approval unless they deem the capitalization adequate. When approval is necessary, minimum equity or maximum debt levels may be imposed. Or countries can use restrictions on the transfer of funds abroad to mitigate the problem of thin capitalization.

Intercompany Transactions and Transfer Prices

As just explained, to minimize taxes in foreign countries with high tax rates, a firm may use excessive debt in controlled entities. To further reduce taxes, the interest rate on the "loan" may be above market rates. An excessive interest rate charged to subsidiaries in high tax countries is but one expense that a company with foreign operations can consider to reduce worldwide taxes.

It is common for a company's subsidiaries in different countries to buy and sell goods from each other. The price for the goods in such intercompany transactions is called a *transfer price*. Corporations seek to establish a transfer price for a transaction so as to minimize worldwide taxes. The GlaxoSmithKline settlement with the IRS cited earlier in this chapter is an example of a dispute regarding international transfer pricing.

National tax authorities require that the transfer price be an *arm's length price transaction*. Acceptable methods for determining this price have been adopted by the OECD in "Transfer Pricing Guidelines for Multinational Enterprises and Tax Administrations," issued in June 2001. We will discuss the acceptable methods in Chapter 13 where we discuss international transfer pricing.

BOTTOM LINE

- Tax management changed beginning in the 1990s to focus on tax risk. Tax directors are now evaluated on more than traditional measures such as the effective tax rate and cash flow impact.
- Tax risk policy of a corporation provides guidance in deciding how much risk should be undertaken.
- Tax risk can be classified into two categories: specific risk areas (transactional risk, operational risk, compliance risk, and financial accounting risk) and general risk areas (portfolio risk, management risk, and reputational risk).
- Typically the tax director reports to the CFO, though other lines of responsibility may exist.
- A corporation's marginal tax rate is the rate at which the next dollar of income would be taxed.
- There are many areas in which corporations are permitted to use different methods of accounting for financial reporting and tax purposes, resulting in timing differences between reported tax expense and actual tax expense.
- The dividend income that a corporation receives from another corporation is effectively taxed at a lower rate than other income because of the dividends-received deduction.
- Because dividends paid by a corporation are not deductible in arriving at taxable income, and because interest paid by a corporation is deductible for tax purposes, this has implications for the corporation's capital structure.
- Depreciation for tax purposes is prescribed by the tax code. The method of depreciation for tax purposes may (and most likely does) differ from the method used for financial accounting purposes.
- Special tax provisions for capital gains effectively reduce the tax paid on these gains. However, tax provisions regarding how much of a gain on a sale of an asset is given special treatment require breaking out the gain into two components: recaptured depreciation (depreciation taken in the past but not really reflective of the asset's decline in value) and capital gain (the appreciation in the asset's value).
- Net operating loss carryovers effectively smooth out the taxes of a business in those cases where taxable income varies significantly from year to year.
- State and local tax codes in the United States in general follow the federal tax code.
- While tax deductions and tax credits both reduce taxes payable, the former reduces taxable income thereby indirectly reducing the tax lia-

bility, whereas the latter is subtracted from the taxes thereby directly reducing the tax liability.

- Taxes paid by corporate enterprises are income taxes (taxes paid to the central government based on corporate income and possibly any local income taxes) and indirect taxes (real estate value-added and sales taxes, as well as miscellaneous taxes on business transactions).
- Tax rates vary by country and a comparison of basic tax rates among countries is complicated because the determination of taxable income differs from country to country.
- Two important tax issues faced by multinational corporations are the treatment of interest expense (the thin capitalization issue) and transfer pricing.

Corporate Risk Management

AGENDA

- Item 1* Explain the role of the CFO in corporate risk management.
- Item 2* Identify the various types of risks to which a corporation is exposed.
- Item 3* Discuss the difference between traditional risk management and enterprise risk management.
- Item 4* Explain the key elements in enterprise risk management.
- Item 5* Identify the objectives of an enterprise risk management system.
- Item 6* Explain what the risk retention decision is.
- Item 7* Describe what is meant by risk finance, risk retention, risk neutralization, and risk transfer.
- Item 8* Explain what risk transfer management is and the vehicles or instruments for transferring risk (traditional insurance, derivatives, alternative risk transfer, and structured finance).
- Item 9* Review the financial accounting treatment for derivative instruments used for hedging.
- Item 10* Distinguish between traditional insurance and alternative risk transfer and describe the vehicles that can be used in alternative risk transfer (insurance-linked notes, captives and mutuals, finite insurance, multiline insurance, and contingent insurance).

All firms face a variety of risks. Scandals such as Enron, WorldCom, Tyco, and Adelphia and tragic events such as 9/11 have reinforced the need for corporate governance committees to set forth that one of the responsibilities of the board of directors is risk management. Moreover, risk management should not be placed at the end of the agenda for a board meeting as “other business” but be a key agenda item that is discussed regularly at board meetings. In practice, the board can provide only oversight and direction. The responsibility of risk management is often delegated by the corporate governance committee to either (1) the audit, finance, or compliance committee of the board or (2) a risk management officer (typically called the chief risk

officer) or a risk management group headed by a risk management officer. Regardless of the structure, to assure effective performance of the risk management process, the committee or group responsible for risk management should have regular interaction with the CFO, internal auditors, general counsel, and managers of business units.

Because of the CFO's role in risk management, in this chapter we discuss the four key processes in risk management: risk identification, risk assessment, risk mitigation, and risk transferring. The process of risk management involves determining which risks to accept, which to neutralize, and which to transfer.

RISK DEFINED

There is no shortage of definitions for *risk*. In everyday parlance, risk is often viewed as something that is negative. But we know that some risks lead to economic gains while others have purely negative consequences. For example, the purchase of a lottery ticket involves an action that results in the risk of the loss equal to the cost of the ticket but potentially has a substantial monetary reward. In contrast, the risk of death or injury from a random shooting is purely a negative consequence.

In the corporate world, accepting risks is necessary to obtain a competitive advantage and generate a profit. In fact, "risk" is derived from the Italian verb *riscare*, which means "to dare." Corporations "dare to" generate profits by taking advantage of the opportunistic side of risk.¹ The former Delaware Supreme Court Chief Justice Norman Veasey in a decision wrote:

Potential profit often corresponds to the potential risk. . . . Stockholders' investment interests . . . will be advanced if corporate directors and managers honestly assess risk and reward and accept for the corporation the highest available risk-adjusted returns that are above the firm's cost of capital.²

We have already seen various definitions of risk throughout this book. In the discussion of capital budgeting in Chapter 16, various measures of risk will

¹ While there is a debate by scholars, the Chinese ideogram for "crisis" is a combination of "danger" or "risk" and "opportunity." True or not, motivational speakers and authors of risk management books use this interpretation to emphasize that along with risk comes opportunity.

² Norman Veasey, "The Role of the Judiciary in Corporate Law, Corporate Governance and Economics Goals," *Company Law Reform in OECD Countries: A Comparative Outlook of Current Trends* (OCED, 2000), pp. 26–27.

be introduced. However, risk as used at the corporate level has a more general meaning than does its use in capital budgeting. J. Francois Outreville, for example, distinguishes between the following types of risk that are useful for ultimately managing risks: financial risk, peril, accident, and hazard.³

When a corporation is exposed to an event that can cause a shortfall in a targeted financial measure or value, this type of risk is called *financial risk*. The financial measure or value could be earnings per share, return on equity, or cash flows, to name some of the important ones. Financial risks include market risk, credit risk, market liquidity risk, operational risk, and legal risk.

Christopher Culp defines perils, accidents, and hazards as follows:

A peril is a natural, man-made, or economic “situation” that can cause an unexpected loss for a firm, the size of which is usually *not* based on the realization of one or more financial variables. A peril thus is essentially a *non-financial risk*. An accident is a specific negative event arising from a peril that gives rise to a loss, and is usually considered unintentional. A hazard is something that increases the probability of a peril-related loss occurring, whether intentional or not.⁴

Christopher Culp provides the following types of perils faced by corporations:

Production—unexpected changes in the demand for products sold, increases in input costs, failures of marketing.

Operational—failures in processes, people, or systems.

Social—adverse changes in social policy (e.g., political incorrectness of a product sold), strained labor relations, changes in fashions and tastes, etc.).

Political—unexpected changes in government, nationalization of resources, war, and so on.

Legal—tort and product liability and other liabilities whose exposures are not driven by financial variables.

Physical—destruction or theft of assets in place, impairment of asset functionality, equipment or mechanical failure, chemical-related perils, energy-related perils, and so on.

Environmental—flood, fire, windstorm, hailstorm, earthquake, cyclone, and so on.⁵

³ J. Francois Outreville, *Theory and Practice of Insurance* (Boston: Kluwer, 1998).

⁴ Christopher L. Culp, *Structured Finance and Insurance: The ART of Managing Capital and Risk* (Hoboken, NJ: John Wiley & Sons, 2006), p. 27.

⁵ *Ibid.*, pp. 27–28.

Examples of hazards that increase the likelihood that there will be a loss for different perils are:

- Human*—fatigue, ignorance, carelessness, smoking;
- Environmental*—weather, noise;
- Mechanical*—weight, stability, speed;
- Energy*—electrical, radiation; and
- Chemical*—toxicity, flammability, combustability.⁶

Risks can also be classified as *core risks* and *non-core risks*. The distinction is important in the management of risk. In attempting to generate a return on invested funds that exceeds the risk-free interest rate, a firm must bear risk. The core risks are those risks that the firm is in the business to bear and the term *business risk* is used to describe this risk. In contrast to core risk, risks that are incidental to the operations of a business are referred to as *non-core risks*. To understand the difference, consider the risk associated with the uncertainty about the price of electricity. For a firm that produces and sells electricity, the risk that the price of electricity that it supplies may decline is a core risk. However, for a manufacturing firm that uses electricity to operate its plants, the price risk associated with electricity (i.e., the price increasing) is a non-core risk. Yet, changing the circumstances could result in a different classification. For example, suppose that the firm producing and selling electricity is doing so on a fixed-price contract for the next three years. In this case, the price risk associated with electricity is a non-core risk.

ENTERPRISE RISK MANAGEMENT

The traditional process of risk management focuses on managing the risks of only parts of the business (products, departments, or divisions), ignoring the implications for the value of the firm. The organization of a risk management process focusing on only parts of a business is referred to as a *silos structure*. What is needed is a process that management can employ to effectively handle uncertainty and evaluate how the risks and opportunities that a firm faces can either create, destroy, or preserve a firm's value. This process should allow management to:

- Align the risk appetite and strategies across the firm.
- Improve the quality of the firm's risk-response decisions.

⁶ Culp, *Structured Finance and Insurance: The ART of Managing Capital and Risk*, p. 28. Culp obtained these examples from Outreville, *Theory and Practice of Insurance*.

- Identify the risks across the firm.
- Manage the risks across the firm.

This process is referred to as *enterprise risk management (ERM)*.

Internal controls provide a mechanism for mitigating risks and increase the likelihood that a firm will achieve its financial objective. As we will explain, ERM goes beyond internal controls in three significant ways. First, when establishing its strategy for the firm, ERM requires that the board consider risks. Second, ERM requires that the board identify what level of risk it is willing to accept. Finally, ERM requires that risk management decisions be made throughout the firm in a manner consistent with the risk policy established.

Definitions of ERM

While corporations and consulting firms may have their own definitions of ERM, the most popular one is that proposed by the Committee of Sponsoring Organizations of the Treadway Commission (COSO). COSO defines ERM as

a process, effected by an entity's board of directors, management and other personnel, applied in strategy setting and across the enterprise, designed to identify potential events that may affect the entity, and manage risk to be within its risk appetite, to provide reasonable assurance regarding the achievement of entity objectives.⁷

This definition and the framework for ERM suggested builds on a 1992 study by COSO where it recommended a uniform approach to developing business controls systems and for assessing their effectiveness.⁸

A broader definition of ERM is provided by the Casualty Actuarial Society (CAS), which describes it as:

the discipline by which an organization in any industry assesses, controls, exploits, finances and monitors risk from all sources for the purposes of increasing the organization's short- and long-term value to its stakeholders.⁹

⁷ *Enterprise Risk Management—Integrated Framework Executive Summary*, Committee of Sponsoring Organizations of the Treadway Commission, September 2004, p. 8.

⁸ *Internal Control—Integrated Framework Executive Summary*, Committee of Sponsoring Organizations of the Treadway Commission, 1992.

⁹ *Overview of Enterprise Risk Management by Casualty Actuarial Society* (May 2003).

There are common attributes to both the COSO and CAS definitions of ERM, as well as other definitions that have appeared in the ERM literature. First, ERM is an ongoing process that provides a structured means for reducing the adverse consequences of big surprises due to natural catastrophes, terrorism, changes in the economic, political, and legal environments, tax litigation, failure of the firm's corporate governance, and product and financial market volatility. In fact, Moody's states that the ultimate objective of a firm's risk management organization should be to make sure that there are no major surprises that place the firm in peril.¹⁰ Second, the starting point for an effective ERM system is at the board level. This means that corporate governance is a critical element.

The term *enterprise* can have different meanings in ERM. As the Society of Actuaries (SOA) points out, there are two main definitions.¹¹ In the first definition "enterprise" has an "Auditing/Process control nuance" in that it is a process that is used in a consistent and effective manner throughout the firm. Within the context of process control, ERM is linked to strategic planning and organizational objectives.

The second definition is in terms of modern portfolio theory (MPT). In this theory, formulated by Markowitz in the 1950s,¹² the focus is on the risk of the portfolio and not the individual securities comprising the portfolio. More specifically, it is not the stand-alone risk of an individual security that is relevant but the contribution of that security to portfolio risk. A portfolio manager can use MPT to create efficient portfolios (i.e., portfolios that offer the maximum expected return for a given level of risk). The portfolio manager will select one of these efficient portfolios given the manager's or client's risk appetite. The manager can use derivatives instruments to alter the risk profile of a portfolio and can use risk budgeting to decide how to allocate risk. In the context of ERM, the enterprise is viewed as a "portfolio of risks." It is not stand-alone risk that is key but the risk to the entire firm, a point we make in Chapter 16 when discussing risk within the context of capital budgeting. The risk profile can be altered using derivative instruments as well as other risk transfer products and strategies discussed later in this chapter.

ERM Process

There is no fixed formula for developing an ERM system, but instead, general principles that are offered as guidance. This is because there is considerable variation in company size, organizational structures (centralized versus

¹⁰ *Moody's Research Methodology: Risk Management Assessments* (July 2004).

¹¹ *Enterprise Risk Management Specialty Guide*, Society of Actuaries (May 2006), p. 9.

¹² Harry M. Markowitz, "Portfolio Selection," *Journal of Finance* 7 (1952), pp. 77-91.

decentralized, for example), and types of risk faced in different industries. So although different internal controls vary from firm to firm, the underlying principles do not. In the literature, there are several proposals for the ERM process.

The four risk objectives of ERM as per the COSO framework are the following:

1. *Strategic*: Supporting the corporation's strategic goals (i.e., high-level goals).
2. *Operations*: Achieving performance goals and taking measures to safeguard against loss through operational efficiency.
3. *Reporting*: Providing reliable financial and operational data and reports internally and externally.
4. *Compliance*: Complying with laws and regulations at all levels (local, state, national, and in other countries where the firm operates).

While there are common risks shared by all firms and there are risks unique to some firms, the building blocks for the ERM process are common to all firms.

Basically, ERM is chiefly concerned with (1) the evaluation of the firm's risk processes and risk controls and (2) the identification and quantification of risk exposures. ERM is broader in its scope than traditional risk management, which focuses on products, departments, or divisions practiced within a silo structure. In ERM, all the risks of a firm are treated as a portfolio of risks and managed on a portfolio or firm level. That is, the risk context is the firm, not individual products, departments, or divisions.

For example, suppose that a firm has a target minimum earnings figure that is established either by its own financial plan or based on Wall Street analysts' consensus earnings. ERM can be used to identify the threats to the firm of hitting that target. Once those risk are identified and prioritized, management can examine the potential shortfall that may occur and decide how to reduce the likelihood that there will be shortfall using some risk transfer strategies.

Themes of ERM

ERM has four themes:

1. Risk control
2. Strategic risk management
3. Catastrophic control
4. Risk management culture¹³

¹³ *Enterprise Risk Management Specialty Guide*, pp. 26–28.

The *risk control* process involves: (1) identifying the risks, (2) evaluating risks, (3) monitoring risks, (4) setting risk limits, (5) avoiding certain risks, (6) offsetting certain risks, (7) transferring risks, and (8) reviewing and evaluating new products.

The process of reflecting risk and risk capital in strategic options from which a corporation can select is called *strategic risk management*. This process involves (1) estimating economic capital, (2) pricing products on a risk-adjusted basis, (3) capital budgeting, and (4) evaluating performance on a risk-adjusted basis.

Extreme events that could threaten the survival of a corporation are referred to as *catastrophic events*. *Catastrophic risk management* involves planning so as to minimize the impact of potential catastrophic events and having in place an early warning system that, if possible, could identify a potential disaster. The process of catastrophic risk management includes (1) trend analysis to identify any patterns suggesting potential emergence of catastrophes, (2) stress testing of the impact of a catastrophe on the financial condition and reputation of the firm, (3) contingency planning for certain scenarios, (4) preparing actions to be taken to effectively communicate with stakeholders and the media when a catastrophe occurs, (5) incorporating the lessons from previous major problems into future plans, and (6) evaluating catastrophic risk transfer alternatives.

The SOA defines *risk management culture* as “the general approach of the firm to dealing with its risks” and the “primary objective is to create a situation where Operational, Strategic and Catastrophic Risk Management take place in an organization without the direct oversight or intervention of the Risk Officer or the Risk Committee.”¹⁴ The process of risk management culture includes (1) identification and measurement of all the firm’s risks, (2) identification of the best risk management practices, (3) development of supporting documentation that can be used by management, (4) communication with all interested parties, and (5) reinforcement by training employees.

Specifying the Firm’s Risk Policy

The implementation of an ERM policy requires that the amount of risk that a firm is willing to accept be specified. Corporations through their board set the boundaries as to how much risk the firm is prepared to accept. Often in referring to risk, the terms *risk appetite* and *risk tolerance* are used interchangeably. However, there is a difference and COSO distinguishes between the two terms as follows:

¹⁴ *Enterprise Risk Management Specialty Guide*, p. 28.

Risk appetite is a higher level statement that considers broadly the levels of risks that management deems acceptable while risk tolerances are more narrow and set the acceptable level of variation around objectives. For instance, a company that says that it . . . does not accept risks that could result in a significant loss of its revenue base is expressing appetite. When the same company says that it does not wish to accept risks that would cause revenue from its top-10 customers to decline by more than 10% it is expressing tolerance. Operating within risk tolerances provides management greater assurance that the company remains within its risk appetite, which, in turn, provides a higher degree of comfort that the company will achieve its objectives.¹⁵

Basically, the firm's risk appetite is the amount of risk exposure that the board decides the firm is willing to accept/retain. When the risk exposure of the firm exceeds the risk appetite threshold, risk management processes are implemented to return the exposure level back within the accepted range.

Once the risk policy of the firm is agreed on by the board, the firm must communicate it to stakeholders via the management discussion section required in SEC filings (8-K and 10-K), press releases, communications with rating agencies, and investor meetings.

Now that the credit rating services are incorporating ERM measures into the credit rating process, it is more important than ever for CFOs to pay attention to the company's ERM system and to communicate this system to stakeholders.¹⁶

MANAGING RISKS

A firm's *retention decision* refers to how a firm elects to manage an identified risk. This decision is more than a risk management decision, it is also a capital structure decision. The choices are (1) retaining the risk, (2) neutralizing the risk, or (3) transferring the risk. Of course, each identified risk faced by the firm can be treated in a different way. As will be explained, for each of the three choices—retention, neutralization, and transfer of risk—there are in turn two further decisions as to how they can be handled.

¹⁵ *Enterprise Risk Management—Integrated Framework Executive Summary*, p. 2.

¹⁶ Anne R. Field, "Rating Risk Practices," *Treasury & Risk* (December/January 2007).

Retained Risk and Risk Finance

The decision by a firm as to which identified risks to retain is based on an economic analysis of the expected benefits versus expected costs associated with bearing that particular risk. The aggregate of all the risks across the firm that it has elected to bear is called its *retained risk*. Because if a retained risk is realized it will adversely impact the firm's earnings, a firm must decide whether a retained risk is to be unfunded or funded.

An *unfunded retained risk* is a retained risk for which potential losses are not financed until they occur. In contrast, a *funded retained risk* is a retained risk for which an appropriate amount is set aside upfront (either as cash or an identified source for raising funds) to absorb the potential loss. For example, in the discussion of tax risk management in Chapter 7, management may decide to hold as cash reserves all or a portion of the potential adverse outcome of a litigation with tax authorities. This management of retained risk is referred to as *risk finance*.

Risk Neutralization

If a firm elects not to retain an identified risk, it can either neutralize the risk or transfer the risk. *Risk neutralization* is a risk management policy whereby a firm acts on its own to mitigate the outcome of an expected loss from an identified risk without transferring that risk to a third party. This can involve reducing the likelihood of the identified risk occurring or reducing the severity of the loss should the identified risk be realized. Risk neutralization management for some risks may be a natural outcome of the business or financial factors affecting the firm. Here is an example involving a business risk. Suppose that a firm expects returns due to product defects that are projected to result in an annual loss of \$30 million to \$50 million and this amount is material relative to its profitability. A firm can introduce improved production processes to reduce the upper range of the potential loss.

As an example involving a financial factor, a U.S. multinational firm will typically have cash inflows and outflows in the same currency such as the Euro. As a result, there is currency risk—the risk that the currency will moved adversely to the firm's exposure in that currency. But this risk has offsetting tendencies if there are both cash inflows and outflows in the same currency. Assuming the currency is the Euro, the cash inflows are exposed to a depreciation of the Euro relative to the U.S. dollar; the cash outflows are exposed to an appreciation of the Euro relative to the U.S. dollar. If the CFO projects future cash inflows over a certain time period of €50 million and a cash outflow over the same period of €40 million, then the firm's net

currency exposure is a €10 million cash inflow. That is, €40 million exposure is naturally hedged.

Risk Transfer

For certain identifiable risks, the firm may decide to transfer the risk from shareholders to a third party. This can be done either by entering into a contract with a counterparty willing to take on the risk the firm seeks to transfer or by embedding that risk in a structured financial transaction thereby transferring it to bond investors willing to accept that risk. In the next section, we look at the various forms of *risk transfer management*.

RISK TRANSFER

The vehicles or instruments for transferring risk include:

- Traditional insurance
- Derivatives
- Alternative risk transfer
- Structured finance

Structured finance or structured financing involves the creation of nontraditional-type securities with risk/return profiles targeted to certain types of investors. Structured finance includes asset securitization, structured notes, and leasing. Since we discuss these forms of financing in later chapters, we will not examine them here. Instead, below we discuss the first three ways that risk can be transferred.

Traditional Insurance

The oldest form of risk transfer vehicle is insurance, with marine insurance more than likely being the oldest type of insurance policy. An insurance policy is a contract whereby an insurance company agrees to make a payment to the insured if a defined adverse event is triggered. The insured receives the protection by paying a specified amount periodically, called the *insurance premium*.

The contract can be a valued contract or unvalued contract. In a *valued contract*, the policy specifies the agreed value of the property insured. With the exception of life insurance contracts purchased by firms, valued contracts are not commonly used as a form of risk transfer. There are exceptions, of course, such as an art museum insuring valuable works of art with

the amount fixed at the time of negotiation of the contract to avoid needing an appraisal of the artwork after the insured event is triggered.

In an *unvalued contract*, also called a *contract of indemnity*, the value of the insured property is not fixed but while there may be a maximum amount payable, the payment is contingent on the actual amount of the insured's loss resulting from the trigger event. A contract of indemnity is the typical type of contract used in risk transfer.

Commercial and corporate insurance policies cover a wide range of property and acts. They include:

- Property damage
- Liability insurance
 - Employer liability
 - Public liability
 - Product liability
 - Construction liability
 - Directors and officers liability
 - Professional indemnity
- Business interruption
- Contractors all rights
- Marine hull
- Commercial motor and fleet
- Goods in transit

Another type of traditional insurance includes credit insurance and financial guarantees.¹⁷ Credit insurance includes *trade credit insurance* whose purpose is to insure against risk of nonpayment resulting from the nonpayment of a customer due to insolvency and protracted defaults (i.e., nonpayment after a specified period of delinquency). These policies can be customized to cover losses on foreign sales due to political risk, predelivery costs, the nondelivery of prepaid goods, and the failure of another party to honor a letter of credit.

Financial guarantees provide for a payment by an insurer to the policy beneficiary if there is loss on a financial obligation held and that loss is the result of a specified event that causes the default. The financial guarantee can call for a payment equal to the entire amount of the loss or for a partial amount of the loss. A financial guarantee can be either a *pure financial guarantee* or a *financial surety bond*, the distinction being who is the beneficiary of the policy. For a pure financial guarantee, the beneficiary of the

¹⁷ For an extensive discussion of credit insurance and financial guarantees, see Chapter 10 in Culp, *Structured Finance and Insurance: The ART of Managing Capital and Risk*.

policy is the credit protection buyer; for a financial surety bond (also called an *insurance wrap*), the beneficiary is not the credit protection buyer but a third party. In this case, the credit protection buyer is a corporation that has issued a financial obligation to the third party.

An alternative to credit insurance is a *letter of credit (LOC)* typically issued by a bank. In this arrangement, the bank issuing the LOC is guaranteeing the performance of the corporation that obtained the LOC. Banks charge a fee for the LOC.

Derivatives

There are capital market products available to management to transfer risks that are not readily insurable by an insurance company. Such risks include risks associated with a rise in the price of commodity purchased as an input, a decline in a commodity price of a product the firm sells, a rise in the cost of borrowing funds, and an adverse exchange-rate movement. The capital market instruments that can be used to provide such protection are called *derivative instruments*. These instruments include futures contracts, forward contracts, option contracts, swap agreements, and cap and floor agreements.

There have been shareholder concerns about the use of derivative instruments by firms. This concern arises from major losses resulting from positions in derivative instruments.¹⁸ However, an investigation of the reason for major losses would show that the losses were not due to derivatives per se, but the improper use of them by management that either was ignorant about the risks associated with using derivative instruments or sought to use them in a speculative manner rather than as a means for managing risk.

How a derivative is treated for financial accounting purposes is governed by the rules set forth in FASB No. 133, "Accounting for Derivative Instruments and Hedging Activities." FASB No. 133 requires that all derivatives be recognized by a corporation on its balance sheet as either assets or liabilities and recorded at their fair market value. The treatment of any gain or loss on a derivative instrument depends on whether it is designated as being used for hedging. If a derivative instrument is not designated as being used for hedging purposes, any gain or loss is recognized in earnings for the period.

The treatment for a derivative instrument designated as being used for hedging purposes depends on what it is being used to hedge. The three categories of hedging are given below, along with the hedge accounting treatment:

¹⁸ Well-publicized losses in the 1990s include Procter & Gamble's losses related to foreign exchange derivatives, Gibson Greetings' losses related to interest rate swaps, and Pier 1 Imports' losses due to the trading of bond futures and options.

1. When a derivative instrument is designated as hedging exposure to changes in the fair value of an asset or liability or an unrecognized commitment, the hedge is referred to as a *fair value hedge*. For such hedges, any gain or loss is recognized in earnings for the period of change but offset by the loss or gain on the hedged item attributable to the risk being hedged. Thus, earnings are impacted to the extent to which the hedge fails to achieve offsetting changes in fair value.
2. When a derivative instrument is designated as hedging exposure to variable cash flows of a forecasted transaction, the hedge is referred to as a *cash flow hedge*.¹⁹ For such hedges, initially the effective portion of the derivative's gain or loss is reported as a component of other comprehensive income (outside earnings); subsequently that gain or loss is reclassified into earnings when the forecasted transaction affects earnings. Thus, the ineffective portion of the gain or loss is reported in earnings immediately.
3. When a derivative instrument is designated as hedging exposure to the foreign currency exposure of a net investment in a foreign operation, an unrecognized commitment, an available-for-sale security, or a foreign-currency-denominated forecasted transaction, any gain or loss is reported in other comprehensive income (outside earnings) as part of the cumulative translation adjustment. Fair value hedge accounting treatment is used for a derivative designated as a hedge of the foreign currency exposure of an unrecognized firm commitment or an available-for-sale security. Cash flow hedge accounting treatment is used for a derivative designated as a hedge of the foreign currency exposure of a foreign-currency-denominated forecasted transaction.

If a corporation wants to apply hedge accounting treatment, when establishing the hedge it is required to specify (1) the methodology that

¹⁹ Here is an example from Berry Plastics Holding Corp. (from S-4 Amendment 12/21/06, p. 544):

The Company consumes plastic resin during the normal course of production. The fluctuations in the cost of plastic resin can vary the costs of production. As part of its risk management strategy, the Company entered into resin forward hedging transactions constituting approximately 15% of its estimated 2005 resin needs and 10% of its 2006 estimated resin needs based on 2004 volumes prior to the Kerr Acquisition. These contracts obligate the Company to make or receive a monthly payment equal to the difference in the unit cost of resin per the contract and an industry index times the contracted pounds of plastic resin. Such contracts are designated as hedges of a portion of the Company's forecasted purchases through 2006 and are effective in hedging the Company's exposure to changes in resin prices during this period.

it will employ for assessing how effective the derivative instrument is for hedging and (2) the measurement approach for determining the ineffective aspect of the hedge. Moreover, the methodology must be consistent with the corporation's approach to managing risk.

Below we describe each major type of derivative instrument. We discuss separately credit derivatives.

Futures Contracts

A *futures contract* is an agreement between a buyer (seller) and an established exchange or its clearinghouse in which the buyer (seller) agrees to take (make) delivery of the underlying at a specified price at the end of a designated period of time. The price at which the parties agree to transact in the future is called the *futures price*. The designated date at which the parties must transact is called the *settlement date* or *delivery date*.

The basic economic function of futures markets is to provide an opportunity for market participants to hedge against the risk of adverse price movements. Futures contracts are products created by exchanges. Futures contracts involving traditional agricultural commodities (such as grain and livestock), imported foodstuffs (such as coffee, cocoa, and sugar), or industrial commodities are traded. Collectively, such futures contracts are known as *commodity futures*. Futures contracts based on a financial instrument or a financial index are known as *financial futures*. Financial futures can be classified as (1) stock index futures, (2) interest rate futures, and (3) currency futures.

Most futures contracts have settlement dates in the months of March, June, September, or December. This means that at a predetermined time in the contract settlement month the contract stops trading, and a price is determined by the exchange for settlement of the contract. A party to a futures contract has two choices on liquidation of the position. First, the position can be liquidated prior to the settlement date. For this purpose, the party must take an offsetting position in the same contract. For the buyer of a futures contract, this means selling the same number of identical futures contracts; for the seller of a futures contract, this means buying the same number of identical futures contracts. The alternative is to wait until the settlement date. At that time the party purchasing a futures contract accepts delivery of the underlying (financial instrument, currency, or commodity) at the agreed-upon price; the party that sells a futures contract liquidates the position by delivering the underlying at the agreed-upon price. For some futures contracts, settlement is made in cash only. Such contracts are referred to as *cash settlement contracts*.

When a party takes a position in the market by buying a futures contract, the party is said to be in a *long position* or to be *long futures*. If,

instead, the party's opening position is the sale of a futures contract, the party is said to be in a *short position* or *short futures*. The buyer of a futures contract will realize a profit if the futures price increases; the seller of a futures contract will realize a profit if the futures price decreases.

Mechanics of a Futures Contract Associated with every futures exchange is a *clearinghouse*, which performs several functions. One of these functions is guaranteeing that the two parties to the transaction will perform. When a party takes a position in the futures market, the clearinghouse takes the opposite position and agrees to satisfy the terms set forth in the contract. Because of the clearinghouse, neither of the parties to a futures contract need worry about the financial strength and integrity of the other party that has taken the opposite side of the contract (called the *counterparty*). After initial execution of an order, the relationship between the two parties ends. The clearinghouse interposes itself as the buyer for every sale and the seller for every purchase. Thus either party is free to liquidate a position without involving the counterparty in the original futures contract, and without worry that the counterparty may default. This is the reason why we define a futures contract as an agreement between a party and a clearinghouse associated with an exchange.

Besides its guarantee function, the clearinghouse makes it simple for parties to a futures contract to unwind their positions prior to the settlement date.

When a position is first taken in a futures contract, the parties to the contract must deposit a minimum dollar amount per contract as specified by the exchange. This amount is called the *initial margin* and is required as deposit for the contract. The initial margin may be in the form of an interest-bearing security. As the price of the futures contract fluctuates, the value of each party's position changes. At the end of each trading day, the exchange determines the settlement price for the futures contract. This price is used to determine the value of each party's position, so that any gain or loss from the position is reflected in each party's equity account. In financial markets, the process of recording the market value of a position is referred to as *marking a position to market* or simply marking to market.

Maintenance margin is the minimum level (specified by the exchange) by which each party's equity position may fall as a result of an unfavorable price movement before that party is required to deposit additional margin. The additional margin deposited is called *variation margin*, and it is an amount necessary to bring the equity in the account back to its initial margin level. Unlike initial margin, variation margin must be in cash, not interest-bearing instruments. If a party has any excess margin in the account, that amount may be withdrawn by that party. If a party to a futures contract

who is required to deposit variation margin fails to do so within 24 hours, the futures position is closed out.

How Futures Are Used to Manage Risk We will use an example to illustrate how futures contracts can be used to manage risk. Consider a producer of crude oil and a company that uses crude oil in the operations of its business. The concern of the crude oil producer is that the price of crude oil will decline, thereby forcing it to sell crude oil at a lower price. The concern of the user of crude oil is that the price of crude oil will increase, resulting in a rise in its production costs.

Consider first the producer of crude oil. Suppose management expects that the crude oil will be available in two months and that management can sell a crude oil futures contract to deliver crude oil two months from now for \$60 per barrel. The number of barrels that is expected to be sold will determine how many barrels of crude oil the firm will seek to deliver in the futures contract. By selling futures, management has locked in a price of \$60 per barrel two months from now. Consequently, even if the price of crude oil two months from now is, say, \$57 per barrel, management will receive \$60 per barrel. If, instead, the price of crude oil two months from now is \$63 per barrel, management has given up the opportunity to benefit from a higher price since it has agreed to accept \$60 per barrel.

Now let's look at the user of crude oil. By buying a crude oil futures contract that settles in two months, management can assure that the price at which it can purchase crude oil will be no higher than \$60 per barrel. So, if crude oil increases to \$63 per barrel, management needs to pay only \$60 per barrel. In contrast, if the price of crude oil two months from now decreases to \$57 per barrel, management gave up the opportunity to benefit from a lower cost for crude oil.

In the same way that these two firms are able to use a futures contract to lock in the future price of crude oil, a firm can use futures contracts to lock in a foreign exchange rate or an interest rate.

Forward Contracts

A *forward contract*, just like a futures contract, is an agreement for the future delivery of the underlying at a specified price at the end of a designated period of time.²⁰ Futures contracts are standardized agreements as to the delivery date (or month) and quality of the deliverable, and are traded on organized exchanges. A forward contract differs in that it is usually nonstandardized (that is, the terms of each contract are negotiated individually between buy-

²⁰ Because forward contracts are used for hedging, some firms refer to these derivative instruments as "forwarding hedging contracts."

er and seller), there is no clearinghouse, and secondary markets are often nonexistent or extremely thin. Unlike a futures contract, which is an exchange-traded product, a forward contract is an over-the-counter (OTC) instrument. Because a forward contract can be customized, forward contracts can be entered into that are longer dated than futures contracts, making them more attractive for long-term hedging.

Although both futures and forward contracts set forth terms of delivery, futures contracts are not intended to be settled by delivery. Forward contracts, in contrast, are intended for delivery. Futures contracts are marked to market at the end of each trading day. Consequently, futures contracts are subject to interim cash flows as additional margin may be required in the case of adverse price movements, or as cash is withdrawn in the case of favorable price movements.

A forward contract may or may not be marked to market, depending on the wishes of the two parties. For a forward contract that is not marked to market, there are no interim cash flow effects because no additional margin is required.

Finally, the parties in a forward contract are exposed to credit risk because either party may default on the obligation. The risk that the counterparty may default is referred to as *counterparty risk*. Counterparty risk is minimal in the case of futures contracts because the clearinghouse associated with the exchange guarantees the other side of the transaction.

Other than these differences, most of what we say about futures contracts applies equally to forward contracts.

Options

An option is a contract in which the *writer of the option* grants the *buyer of the option* the right, but not the obligation, to purchase from or sell to the writer an asset at a specified price within a specified period of time (or at a specified date). The writer, also referred to as the *seller*, grants this right to the buyer in exchange for a certain sum of money, which is called the *option price* or *option premium*. The price at which the asset may be bought or sold is the *exercise price* or *strike price* and the date after which an option is void is the *expiration date*. As with a futures contract, the asset that the buyer has the right to buy and the seller is obligated to sell is referred to as the *underlying*.

When an option grants the buyer the right to purchase the underlying from the writer (seller), it is referred to as a *call option*, or *call*. When the option buyer has the right to sell the underlying to the writer, the option is referred to as a *put option*, or *put*.

An option is also categorized according to when the option buyer may exercise the option. There are options that may be exercised at any time up to and including the expiration date. Such an option is referred to as an *American option*. There are options that may be exercised only at the expiration date; an option with this feature is called a *European option*. An option that can be exercised before the expiration date but only on specified dates is called a *Bermuda option*.

The maximum amount that an option buyer can lose is the option price. The maximum profit that the option writer can realize is the option price. The option buyer has substantial upside return potential, while the option writer has substantial downside risk.

There are no margin requirements for the buyer of an option once the option price has been paid in full. Because the option price is the maximum amount that the investor can lose, no matter how adverse the price movement of the underlying, there is no need for margin. Because the writer of an option has agreed to accept all of the risk (and none of the reward) of the position in the underlying, the writer is generally required to put up the option price received as margin. In addition, as price changes occur that adversely affect the writer's position, the writer is required to deposit additional margin (with some exceptions) as the position is marked to market.

Exchange-Traded versus OTC Options Options, like other financial instruments, may be traded either on an organized exchange or in the OTC market. Exchange-traded options have three advantages over OTC options (also known as *dealer options*). First, the exercise price and expiration date of the contract are standardized. Second, as in the case of futures contracts, the direct link between buyer and seller is severed after the order is executed because of the interchangeability of exchange-traded options. The clearinghouse associated with the exchange where the option trades performs the same function in the options market that it does in the futures market. Finally, the transactions costs are lower for exchange-traded options than for OTC options.

The higher cost of an OTC option reflects the cost of customizing the option for the many situations where a corporation seeking to use an option to manage risk needs to have a tailor-made option because the standardized exchange-traded option does not satisfy its objectives. While an OTC option is less liquid than an exchange-traded option, this is typically not of concern to the user of such an option. Most corporations who use OTC options do so as part of a financing strategy or price protection against unfavorable changes in prices of its inputs or exchange rates.

Differences between Options and Futures Contracts Notice that unlike in a futures contract, one party to an option contract is not obligated to transact—specifically, the option buyer has the right but not the obligation to transact. The option writer does have the obligation to perform. In the case of a futures contract, both buyer and seller are obligated to perform. Of course, a futures buyer does not pay the seller to accept the obligation, while an option buyer pays the seller a fee for granting the right, the option price.

Consequently, the risk/reward characteristics of the two contracts are also different. In the case of a futures contract, the buyer of the contract realizes a dollar-for-dollar gain when the price of the futures contract increases and suffers a dollar-for-dollar loss when the price of the futures contract drops. The opposite occurs for the seller of a futures contract. Because of this relationship, futures are referred to as having a “linear payoff.”

Options do not provide this symmetric risk/reward relationship. The most that the buyer of an option can lose is the option price. While the buyer of an option retains all the potential benefits, the gain is always reduced by the amount of the option price. The maximum profit that the writer may realize is the option price; this is offset against substantial downside risk. Because of this characteristic, options are referred to as having a “nonlinear payoff.”

The difference in the type of payoff between futures and options is extremely important because market participants can use futures to protect against symmetric risk and options to protect against asymmetric risk.

Swaps

A *swap* is an agreement whereby two parties (called counterparties) agree to exchange periodic payments. The dollar amount of the payments exchanged is based on some predetermined dollar principal, which is called the *notional principal amount* or simply *notional amount*. A swap is an OTC instrument. Hence, the counterparties to a swap are exposed to counterparty risk.

Effectively, a swap is nothing more than a package of forward contracts; however, it is not a redundant contract for several reasons. First, in many markets where there are forward and futures contracts, the longest maturity does not extend out as far as that of a typical swap. Second, a swap is a more transactionally efficient instrument. By this we mean that in one transaction a firm can effectively establish a payoff equivalent to a package of forward contracts. In contrast, each forward contract would have to be negotiated separately. Third, swaps are more liquid than forward contracts, particularly long-dated (i.e., long-term) forward contracts.

The three types of swaps typically used by nonfinance corporations are interest rate swaps, currency swaps, and commodity swaps. We illustrate these types of swaps below.

Interest Rate Swap In an *interest rate swap*, the counterparties swap payments in the same currency based on an interest rate. For example, typically one of the counterparties pays a fixed interest rate and the other party a floating interest rate. The floating interest rate is referred to as the *reference rate*.

For example, suppose the counterparties to a swap are Farm Equip Corporation (a manufacturing firm) and Bank of America (BoA). The notional amount of this swap is \$100 million and the term of the swap is five years. Every year for the next five years, Farm Equip Corporation has agreed to pay BoA 9% per year, while BoA agrees to pay Farm Equip Corporation the one-year London interbank offered rate (LIBOR). LIBOR is the reference rate. This means that every year, Farm Equip Corporation will pay \$9 million (9% times \$100 million) to BoA. The amount BoA will pay Farm Equip Corporation depends on LIBOR. For example, if one-year LIBOR is 6%, BoA will pay Farm Equip Corporation \$6 million (6% times \$100 million).

Interest rate swaps are used by a CFO in arranging debt financing in order to better match the cash flow characteristics of the corporation's liabilities. For example, a CFO seeking fixed-rate financing may issue a floating-rate note and use an interest rate swap to convert the debt from floating to fixed. The motivation for a CFO to do so may be to take advantage of a lower funding cost opportunity that may exist in the floating-rate market for the company's debt.

Currency Swaps In a *currency swap*, two parties agree to exchange contractually specified amounts of two different currencies at the inception of the contract and then exchange payments of interest and amortization of principal over time based on contractually specified rules. Currency swaps are classified as either *fixed/fixed currency swaps* and *cross-currency swaps*.

In a fixed/fixed currency swap there are fixed interest payments made by both parties and there may or may not be an exchange of principal at the inception of the contract. In a cross-currency swap, there is an exchange of principal at both the inception and maturity date of the swap and in the interim there are exchanges of interest rate payment (as with an interest rate swap) in different currencies.

Currency swaps are used by corporations in currency management and to raise funds outside of their home currency and then swap the payments into their home currency. This allows a corporation to eliminate currency

risk (i.e., unfavorable exchange rate or currency movements) when there is a long-term transaction (such as borrowing) outside of its domestic currency.

Commodity Swaps In a *commodity swap*, the exchange of payments by the counterparties is based on the value of a particular physical commodity. Physical commodities include precious metals, base metals, energy stores (such as natural gas or crude oil), and food (including pork bellies, wheat, and cattle). Most commodity swaps involve oil.

For example, suppose that the two counterparties to this swap agreement are Comfort Airlines Company, a commercial airline, and Prebon Energy (an energy broker). The notional amount of the contract is 1 million barrels of crude oil each year and the contract is for three years. The swap price is \$60 per barrel. Each year for the next three years, Comfort Airlines Company agrees to buy 1 million barrels of crude oil for \$60 per barrel. So, each year Comfort Airlines Company pays \$60 million to Prebon Energy (\$60 per barrel times 1 million barrels) and receives 1 million barrels of crude oil.

The motivation for Comfort Airlines of using the commodity swap is that it allows the company to lock in a price for 1 million barrels of crude oil at \$60 per barrel regardless of how high crude oil's price increases over the next three years.

Cap and Floor Agreements

There are agreements available in the capital market whereby one party, for a fee (premium), agrees to compensate the other if a designated reference is different from a predetermined level. The party that will receive payment if the designated reference differs from a predetermined level and pays a premium to enter into the agreement is called the buyer. The party that agrees to make the payment if the designated reference differs from a predetermined level is called the seller.

When the seller agrees to pay the buyer if the designated reference exceeds a predetermined level, the agreement is referred to as a *cap*. The agreement is referred to as a *floor* when the seller agrees to pay the buyer if a designated reference falls below a predetermined level.

In a typical cap or floor, the designated reference is either an interest rate or commodity price. The predetermined level is called the *exercise value*. As with a swap, a cap and a floor have a notional amount. Only the buyer of a cap or a floor is exposed to counterparty risk.

In general, the payment made by the seller of the cap to the buyer on a specific date is determined by the relationship between the designated refer-

ence and the exercise value. If the former is greater than the latter, then the seller pays the buyer an amount determined as follows:

$$\text{Notional amount} \times [\text{Actual value of designated reference} - \text{Exercise value}]$$

If the designated reference is less than or equal to the exercise value, then the seller pays the buyer nothing.

For a floor, the payment made by the seller to the buyer on a specific date is determined as follows. If the designated reference is less than the exercise value, then the seller pays the buyer an amount computed as follows:

$$\text{Notional amount} \times [\text{Exercise value} - \text{Actual value of designated reference}]$$

If the designated reference is greater than or equal to the exercise value, then the seller pays the buyer nothing.

The following example illustrates how a cap works. Suppose that the FPK Bookbinders Company enters into a five-year cap agreement with PNC Bank with a notional amount of \$50 million. The terms of the cap specify that if one-year LIBOR exceeds 8% on December 31 each year for the next five years, PNC Bank (the seller of the cap) will pay FPK Bookbinders Company the difference between 8% (the exercise value) and LIBOR (the designated reference). The fee or premium FPK Bookbinders Company agrees to pay PNC Bank each year is \$200,000.

The payment made by PNC Bank to FPK Bookbinders Company on December 31 for the next five years based on LIBOR on that date will be as follows. If one-year LIBOR is greater than 8%, then PNC Bank pays \$50 million multiplied by (Actual value of LIBOR – 8%). If LIBOR is less than or equal to 8%, then PNC Bank pays nothing.

So, for example, if LIBOR on December 31 of the first year of the cap is 10%, PNC Bank pays FPK Bookbinders Company \$1 million as shown below:

$$\$50 \text{ million} \times [10\% - 8\%] = \$1 \text{ million}$$

In a cap or floor, the buyer pays a fee that represents the maximum amount that the buyer can lose and the maximum amount that the seller of the agreement can gain. The only party that is required to perform is the seller. The buyer of a cap benefits if the designated reference rises above the exercise value because the seller must compensate the buyer. The exercise value can be a reference interest rate or an exchange rate, for example. The buyer of a floor benefits if the designated reference falls below the exercise value because the seller must then compensate the buyer.

In essence the payoff of these contracts is the same as that of an option. A call option buyer pays a fee and benefits if the value of the option's underlying (or equivalently, designated reference) is higher than the exercise price at the expiration date. A cap has a similar payoff. A put option buyer pays a fee and benefits if the value of the option's underlying (or equivalently, designated reference) is less than the exercise price at the expiration date. A floor has a similar payoff. An option seller is entitled only to the option price. The seller of a cap or floor is entitled only to the fee.

We can easily see the use of a cap or a floor. In a cap that involves an interest rate, a corporation seeking funds can use a swap to set a maximum interest rate for its borrowing cost. In a cap that involves the price of a commodity, the cap sets a maximum price for the commodity and is therefore used by a manufacturer to eliminate the price risk associated with buying that commodity. In a floor that involves a commodity, a manufacturer can use such a contract to protect against a decline in a product it sells.

Credit Derivatives

Credit derivatives allow the transfer of credit risk from parties who want to shed credit risk to counterparties willing to accept credit risk. The eight major credit derivatives according to the British Bankers Association are (1) credit default swaps; (2) index swaps such as credit default index swaps; (3) basket default swaps; (4) asset swaps; (5) total return swaps; (6) portfolio/synthetic collateralized debt obligations; and (6) credit-linked notes. We will discuss here only credit default swaps and credit-linked notes.²¹

Credit Default Swaps In a credit default swap, the protection buyer pays a fee to the protection seller in exchange for the right to receive a payment conditioned upon the occurrence of a credit event by the *reference entity*. Should a "credit event" occur, the protection seller must make a payment and the contract terminates. If no credit event occurs by the maturity of the swap, both sides terminate the swap agreement and no further obligations are incurred. The tenor, or length of time of a credit default swap, is typically three to five years. In a typical credit default swap, the protection buyer pays for the protection premium over several settlement dates rather than upfront. A standard credit default swap specifies quarterly payments.

The International Swap and Derivatives Association (ISDA) developed a standard contract that is used by parties for trades in credit derivative con-

²¹ For a further discussion of credit derivatives, see Chapter 3 in Frank J. Fabozzi, Henry A. Davis, and Moorad Choudhry, *Introduction to Structured Finance* (Hoboken, NJ: John Wiley & Sons, 2006).

tracts. The documentation identifies the reference entity and/or the reference obligation. The reference entity, also referred to as the reference issuer, is the issuer of the debt instrument. The *reference obligation*, also referred to as the *reference asset*, is the particular debt issue for which the credit protection is being sought. For example, a reference entity could be Viacom. The reference obligation would be a specific Viacom bond issue.

The payment by the protection seller to the protection buyer in a credit default swap is contingent upon a credit event occurring. The *1999 ISDA Credit Derivatives Definitions* publication provides a list of eight credit events that seek to capture every type of situation that could cause the credit quality of the reference entity to deteriorate or cause the value of the reference obligation to decline: (1) bankruptcy; (2) credit event upon merger; (3) cross acceleration; (4) cross default; (5) downgrade; (6) failure to pay; (7) repudiation/moratorium; and (8) restructuring. Each of these credit events is defined in the “1999 Definitions.”

In January 2003, the ISDA published its revised credit events definitions in the *2003 ISDA Credit Derivative Definitions* (referred to as the “2003 Definitions”). The revised definitions reflected amendments to several of the definitions for credit events set forth in the 1999 Definitions. Specifically, there were amendments for bankruptcy, repudiation, and restructuring. The major change was to restructuring, whereby the ISDA allows parties to a given trade to select in trade from among different definitions of restructuring.²²

Credit-Linked Notes²³ A *credit-linked note (CLN)* is debt obligation that links the return paid by the issuer of the security and the credit-related performance of some underlying asset. A CLN is often used as a financing vehicle by borrowers in order to hedge against credit risk. Many CLNs are issued directly by banks and corporate borrowers in the same way as conventional bonds.

A standard CLN is a security, usually issued by an investment-graded entity, that has an interest payment and fixed maturity structure similar to a standard bond. In contrast to such a bond, the performance of the CLN, including the maturity value, is linked to the performance of a specified underlying asset or assets as well as that of the issuing entity. CLNs are usually issued at par and purchased by investors to enhance the yield received on their holdings. Hence, the issuer of the CLN is the protection buyer and the buyer of the note is the protection seller.

²² They are (1) no restructuring, (2) “full” or “old” restructuring, (3) “modified restructuring,” and (4) “modified modified restructuring.”

²³ For a further discussion of CLNs, see Chapter 9 in Fabozzi, Davis, and Choudhry, *Introduction to Structured Finance*.

Essentially CLNs are hybrid instruments that combine a pure credit risk exposure with a standard bond. The CLN pays regular coupons; however, the credit derivative element is usually set to allow the issuer to decrease the principal amount, and/or the coupon interest, if a specified credit event occurs.

CLNs may be issued directly by a financial or corporate entity or via a special-purpose entity (SPE). They have been issued with several different forms of credit-linking. For instance, a CLN may have its return performance linked to the issuer's, or a specified reference entity's, credit rating, risk exposure, financial performance, or circumstance of default.

Alternative Risk Transfer

Alternative risk transfer (ART), also known as *structured insurance*, provides unique ways to transfer the increasingly complex risks faced by corporations that cannot be handled by traditional insurance and has led to the growth in the use of this form of risk transfer. These products combine elements of traditional insurance and capital market instruments to create highly sophisticated risk transfer strategies tailored for a corporate client's specific needs and liability structure that traditional insurance cannot handle. For this reason, ART is sometimes referred to as "insurance-based investment banking." According to a September 2006 report by Conning Research & Consulting, traditional insurance covers roughly 70% of the commercial insurance market in the United States and the balance is provided by ART.²⁴

ART includes:

- Insurance-linked notes
- Captives and mutuals
- Finite insurance
- Multiline insurance
- Contingent insurance

We briefly review each of these below.²⁵

²⁴ "Alternative Markets: Structural and Functional Evolution," Conning Research & Consulting, Inc., September 2006.

²⁵ For a more detailed discussion of ART, see Chapters 22–26 in Culp, *Structured Finance and Insurance: The ART of Managing Capital and Risk* and Chapters 4–10 in Erik Banks, *Alternative Risk Transfer: Integrated Risk Management Through Insurance, Reinsurance and the Capital Markets* (Hoboken, NJ: John Wiley & Sons, 2004).

Insurance-Linked Notes

Insurance-linked notes (ILNs) have been primarily used by life insurers and property and casualty insurers to bypass the conventional reinsurance market and synthetically reinsure against losses by tapping the capital markets. Basically, an ILN is a means for securitizing insurance risk. ILNs can be classified as single-peril and multi-peril bonds. The former ILNs are typically referred to as *cataprophe-linked bonds* or simply *cat bonds*. Typically cat bonds are issued through a special-purpose entity.

The first use of cat bonds in corporate risk management by a noninsurance company was by the owner/operator of Tokyo Disneyland, Oriental Land Co. Rather than obtain traditional insurance against earthquake damage for the park, it issued a \$200 million cat bond in 1999. Three years later, Vivendi Universal obtained protection for earthquake damage for its studios (Universal Studios) in California by issuing a \$175 million cat bond with a maturity of 3.5 years. Moreover, the bond had a lower coupon rate than a similarly rated corporate bond.²⁶

While cat bonds have primarily been used for perils such as earthquakes and hurricanes, corporations are using them in other ways. For example, as explained in Chapter 18, the risk to the lessor in a leasing transaction is that the residual value of the leased equipment is below its expected value when the lease was negotiated. Toyota Motor Credit Corp., for example, was concerned that the 260,000 1998 motor vehicles (cars and light-duty trucks) it leased to customers would decline in value if the used-car market weakened. To protect itself, Toyota issued a cat bond that insured against a loss in market value of the fleet of leased motor vehicles. As another example, the sponsors of the World Cup, the Fédération Internationale de Football Association (FIFA), issued a \$260 million cat bond to protect itself against a (terrorism-related) cancellation of the 2006 event in Germany.

Captives

A parent company, trade association, or a group of companies within an industry can set up a captive insurance company. These entities can be used for financing the retention risk that we described earlier as well as risk transfer. In order to benefit from a captive, a company needs good information to evaluate the risks that are being incurred by the captive and have sufficient financial resources for funding an annual premium that is large enough to justify the costs of setting up and maintaining a captive. In a mutual insurance company the owners of the company are the policyholders. A group of companies can create a mutual insurance company to insure against specific

²⁶ Alex Mathias, "Are Cat Bonds Changing Course?" *Environmental Finance Insurance*, April 2003.

types of risk common to them. Basically, a mutual insurance company is a form of self-insurance.

According to the report by Conning Research & Consulting cited earlier, self-insurance and single-parent captives account for 90% of the ART market.

Finite Insurance

Finite insurance is an insurance policy that sharply limits the amount of the loss that the insurer can realize. The controversy associated with this type of insurance is whether it truly transfers risk from a corporation seeking protection to the insurer. The reason is that typically for this type of policy the corporation seeking protection makes a large premium to the insurer, the amount being sufficient to cover the insurer's expected losses. The premium is then held by an insurer in an interest-bearing account. If at the end of the policy's term the actual losses are less than the premium, the insurer pays the difference to the corporation. However, if the losses exceed the premium, the corporation makes an additional premium payment to the insurer for the difference.

Basically, it has been argued that finite insurance provided a means not for risk management but for earnings management. Public and regulatory awareness of the problem with finite insurance resulted from the SEC enforcement action against Brightpoint Inc. and American International Group (AIG). The SEC charged AIG with accounting fraud because of the insurer's role in devising and selling an "insurance" product that Brightpoint Inc. used to report false and misleading financial statements that concealed \$11.9 million in losses that Brightpoint sustained in 1998. Without admitting or denying the SEC's allegations, AIG and Brightpoint agreed to pay a civil penalty of \$10 million and \$450,000, respectively. There were further SEC investigations of other issuers of finite insurance, as well as then-New York Attorney General Eliot Spitzer's investigation of a \$500 million finite insurance deal between AIG and General Re.

These actions have made CFOs reluctant to use finite insurance, particularly because there is the risk that such insurance might result in an earnings restatement. According to experts, however, the major concern with finite coverage is not that it may allow earnings manipulation but that it fails to transfer risk.

Experts in ART have argued that there are legitimate uses for finite insurance. Culp, for example, states that finite insurance "leads to a higher quality of earnings than if the firm doesn't reserve for a major loss or just tries to set money aside internally,"²⁷ further noting that companies can

²⁷ David M. Katz, "Finite Insurance: Beyond the Scandals," *CFO.com*. April 14, 2005, p. 2.

use finite insurance to shield them from allegations that they are setting up “cookie jar” reserves to inflate future results. A second advantage pointed out by some experts in ART is that the coverage provided by finite insurance can assist companies that are reluctant to purchase traditional insurance to fix the cost of risk exposures that are difficult to quantify over a span of years. Finally, it is argued that finite insurance is particularly useful in “covering severe risks that are outside the core functions of a company.”²⁸

Multiline Insurance

Multiline insurance offers a tool for better integrated risk management by offering one large aggregate limit across several lines of business such as liability, property, and business interruption. The insurer makes a payment if the combined losses on all lines reach a specified amount. The programs usually operate on a multiyear basis. The corporation deals with only one insurer rather than several insurers covering different lines. Moreover, the corporation only has to renew the program every three to five years, thereby reducing the time the chief risk officer must devote to negotiating insurance contracts each year. The flexibility of creating multiline insurance allows an insurer to work with a corporation to obtain tailor-made coverage based on the corporation’s needs.

Contingent Insurance

Contingent insurance, more popularly referred to as as contingent cover, is an option granted by an insurance company giving a corporation the right to enter into an insurance contract at some future date. All of the terms of the insurance contract that can be entered into, including the premium that must be paid if the option is exercised, are specified at the time the contingent cover policy is purchased by the corporation. Contingent cover includes premium protection options, contingent cover embedded in existing programs, and contingent insurance-linked notes.²⁹

BOTTOM LINE

- Financial risk is the exposure of a corporation to an event that can cause a shortfall in a targeted financial measure or value and includes market risk, credit risk, market liquidity risk, operational risk, and legal risk.

²⁸ Katz, “Finite Insurance: Beyond the Scandals,” p. 2.

²⁹ See Chapter 26 in Culp, *Structured Finance and Insurance: The ART of Managing Capital and Risk*.

- Risks can also be classified as *core risks* and *non-core risks*. Core risks, or business risks, are those risks that the firm is in the business to bear; non-core risks are risks that are incidental to the operations of a business.
- The traditional process of risk management focused on managing the risks of only parts of the business, ignoring the implications for the value of the firm.
- Enterprise risk management makes it possible for management to align the risk appetite and strategies across the firm, improve the quality of the firm's risk-response decisions, identify the risks across the firm, and manage the risks across the firm.
- ERM requires that the board consider risks, the board identify what level of risk it is willing to accept, and that risk management decisions be made throughout the firm in a manner consistent with the established risk policy of the firm. There is no fixed formula for developing an ERM system, but instead, general principles that are offered as guidance.
- ERM is chiefly concerned with evaluation of the firm's risk processes and risk controls and the identification and quantification of risk exposures.
- The four themes of ERM are risk control, strategic risk management, catastrophic control, and risk management culture.
- To implement an ERM system, the amount of risk that a firm is willing to accept must be specified by the board. The risk policy established by the firm must be communicated to stakeholders and rating agencies.
- The retention decision refers to how a firm elects to manage an identified risk, with the three choices being risk retention, risk neutralization, and risk transfer.
- A retained risk can be a funded retained risk or an unfunded retained risk. Risk finance refers to the management of retained risk.
- Risk neutralization is a risk management policy whereby a firm acts on its own to mitigate the outcome of an expected loss from an identified risk without transferring that risk to a third party.
- Risk transfer management involves strategies for dealing with identifiable risks that the the firm decides to transfer to a third party.
- The vehicles or instruments for transferring risk include traditional insurance, derivatives, alternative risk transfer, and structured finance.
- Structured finance or structured financing involves the creation of nontraditional-type securities with risk/return profiles that target certain types of investors.
- Traditional commercial and corporate insurance policies cover a wide range of property and acts. Traditional insurance also includes credit insurance (trade credit insurance) and financial guarantees.
- Financial guarantees, which can be either a pure financial guarantee (corporation is the beneficiary) or a financial surety bond (third party

is the beneficiary), provide for a payment by an insurer to the insured if there is loss on a financial obligation to the insured and that loss is the result of a specified event that causes the default.

- Derivatives are capital market instruments that can be used for risk management transfer. They include futures, forwards, options, swaps, caps, floors, and credit derivatives.
- FASB No. 133 specifies the rules for reporting transactions in derivative instruments; there are special rules when the derivative instrument is designated as being used for hedging purposes: fair value hedge accounting and cash flow hedge accounting.
- Credit default swaps and credit-linked notes, two types of credit derivatives, allow the transfer of credit risk from parties who want to shed credit risk to counterparties willing to accept credit risk.
- Alternative risk transfer (ART) provides unique ways a corporation can transfer complex risks that cannot be handled by traditional insurance by combining elements of traditional insurance and capital market instruments.
- ART includes insurance-linked notes (one particular type being cat bonds), captives and mutuals, finite insurance, multiline insurance, and contingent insurance.

PART

Three

Performance Evaluation

Financial Ratio Analysis

AGENDA

- Item 1* Explain how financial ratio analysis can be used to help assess the operating performance and financial condition of a company.
- Item 2* Identify the five aspects of operating performance and financial condition that financial ratio analysis can be used to evaluate and their limitations: return on investment, liquidity, profitability, activity, and financial leverage.
- Item 3* Differentiate among the following return-on-investment ratios and what they indicate for a company's performance: basic earning power, return on assets, and return on equity.
- Item 4* Explain how the DuPont system is used to break down return ratios into their components to determine which areas are responsible for a firm's performance.
- Item 5* Describe what is meant by liquidity.
- Item 6* Explain the following measures of liquidity: current ratio and quick ratio.
- Item 7* Relate each of the following measures of profitability to the performance of a company: gross profit margin, operating profit margin, and net profit margin.
- Item 8* Explain the following activity ratios to evaluate how efficiently a firm is employing its assets: inventory turnover ratio, accounts receivable turnover ratio, total assets turnover ratio, and fixed assets turnover ratio.
- Item 9* Describe what is meant by the financial risk of a firm.
- Item 10* Describe each of the following financial leverage ratios and discuss how each relates to the evaluation of a company's financial risk: debt-to-assets ratio, interest coverage ratio, fixed charge coverage ratio, and cash flow interest coverage ratio.
- Item 11* Describe what common-size analysis is and how the method can be used in analyzing a company.
- Item 12* Identify the concerns in using financial ratio analysis.

In this chapter, we explain and illustrate financial ratios—one of the tools of financial analysis. In financial ratio analysis we select the relevant information—primarily the financial statement data—and evaluate it. We show how to incorporate market data and economic data in the analysis of financial ratios. Finally, we show how to interpret financial ratio analysis, identifying the pitfalls that occur when it's not done properly.

Financial analysis is one of the many tools useful in valuation because it helps the CFO gauge returns and risks. We begin the analysis with a fictitious firm as our example, allowing us to use simplified financial statements and to become more comfortable with the tools of financial analysis. After we cover the basics, we use these same tools with data from an actual firm in an integrative example.

RATIOS AND THEIR CLASSIFICATION

A *ratio* is a mathematical relation between two quantities. Suppose you have 200 apples and 100 oranges. The ratio of apples to oranges is 200/100, which we can conveniently express as 2:1 or 2. A financial ratio is a comparison between one bit of financial information and another. Consider the ratio of current assets to current liabilities, which we refer to as the current ratio. This ratio is a comparison between assets that can be readily turned into cash—current assets—and the obligations that are due in the near future—current liabilities. A current ratio of 2 or 2:1 means that we have twice as much in current assets as we need to satisfy obligations due in the near future.

Ratios can be classified according to the way they are constructed and the financial characteristic they are describing. For example, we will see that the current ratio is constructed as a coverage ratio (the ratio of current assets—available funds—to current liabilities—the obligation) that we use to describe a firm's liquidity (its ability to meet its immediate needs).

There are as many different financial ratios as there are possible combinations of items appearing on the income statement, balance sheet, and statement of cash flows. We can classify ratios according to how they are constructed or according to the financial characteristic that they capture.

Ratios can be constructed in the following four ways:

1. As a *coverage ratio*. A coverage ratio is a measure of a firm's ability to "cover," or meet, a particular financial obligation. The denominator may be any obligation, such as interest or rent, and the numerator is the amount of the funds available to satisfy that obligation.

2. As a *return ratio*. A return ratio indicates a net benefit received from a particular investment of resources. The net benefit is what is left over after expenses, such as operating earnings or net income, and the resources may be total assets, fixed assets, inventory, or any other investment.
3. As a *turnover ratio*. A turnover ratio is a measure of how much a firm gets out of its assets. This ratio compares the gross benefit from an activity or investment with the resources employed in it.
4. As a *component percentage*. A component percentage is the ratio of one amount in a financial statement, such as sales, to the total of amounts in that financial statement, such as net profit.

In addition, we can also express financial data in terms of time—say, how many days’ worth of inventory we have on hand—or on a per-share basis—say, how much a firm has earned for each share of common stock. Both are measures we can use to evaluate operating performance or financial condition.

When we assess a firm’s operating performance, a concern is whether the company is applying its assets in an efficient and profitable manner. When a CFO assesses a firm’s financial condition, a concern is whether the company is able to meet its financial obligations. The CFO can use financial ratios to evaluate five aspects of operating performance and financial condition:

1. Return on investment
2. Liquidity
3. Profitability
4. Activity
5. Financial leverage

There are several ratios reflecting each of the five aspects of a firm’s operating performance and financial condition. We apply these ratios to the Fictitious Corporation, whose balance sheets, income statements, and statement of cash flows for two years are shown in Tables 9.1, 9.2, and 9.3, respectively. We refer to the most recent fiscal year for which financial statements are available as the “current year.” The “prior year” is the fiscal year prior to the current year.

The ratios we introduce here are by no means the only ones that can be formed using financial data, though they are some of the more commonly used. After becoming comfortable with the tools of financial analysis, a CFO will be able to create ratios that serve a particular evaluation objective.

TABLE 9.1 Fictitious Corporation Balance Sheets for Years Ending December 31, in Thousands

| | Current Year | Prior Year |
|---|----------------|--------------|
| <i>ASSETS</i> | | |
| Cash | \$400 | \$200 |
| Marketable securities | 200 | 0 |
| Accounts receivable | 600 | 800 |
| Inventories | <u>1,800</u> | <u>1,000</u> |
| Total current assets | \$3,000 | \$2,000 |
| Gross plant and equipment | \$11,000 | \$10,000 |
| Accumulated depreciation | <u>(4,000)</u> | <u>3,000</u> |
| Net plant and equipment | 7,000 | 7,000 |
| Intangible assets | <u>1,000</u> | <u>1,000</u> |
| Total assets | \$11,000 | \$10,000 |
| <i>LIABILITIES AND SHAREHOLDERS' EQUITY</i> | | |
| Accounts payable | \$500 | \$400 |
| Other current liabilities | 500 | 200 |
| Long-term debt | <u>4,000</u> | <u>5,000</u> |
| Total liabilities | \$5,000 | \$5,600 |
| Common stock, \$1 par value; | | |
| Authorized 2,000,000 shares | | |
| Issued 1,500,000 and 1,200,000 shares | 1,500 | 1,200 |
| Additional paid-in capital | 1,500 | 800 |
| Retained earnings | <u>3,000</u> | <u>2,400</u> |
| Total shareholders' equity | 6,000 | 4,400 |
| Total liabilities and shareholders' equity | \$11,000 | \$10,000 |

RETURN-ON-INVESTMENT RATIOS

Return-on-investment ratios compare measures of benefits, such as earnings or net income, with measures of investment. For example, if a CFO wants to evaluate how well the firm uses its assets in its operations, he could calculate the *return on assets*—sometimes called the *basic earning power ratio*—as the ratio of earnings before interest and taxes (EBIT) (also known as *operating earnings*) to total assets:

TABLE 9.2 Fictitious Corporation Income Statements for Years Ending December 31, in Thousands

| | Current Year | Prior Year |
|---|----------------|----------------|
| Sales | \$10,000 | \$9,000 |
| Cost of goods sold | <u>(6,500)</u> | <u>(6,000)</u> |
| Gross profit | \$3,500 | \$3,000 |
| Lease expense | (1,000) | 1,000) |
| Administrative expense | <u>(500)</u> | <u>(500)</u> |
| Earnings before interest and taxes (EBIT) | \$2,000 | \$2,000 |
| Interest | <u>(400)</u> | <u>(500)</u> |
| Earnings before taxes | \$1,600 | \$1,500 |
| Taxes | <u>(400)</u> | <u>(500)</u> |
| Net income | \$1,200 | \$1,000 |
| Preferred dividends | <u>(100)</u> | <u>(100)</u> |
| Earnings available to common shareholders | \$1,100 | \$900 |
| Common dividends | <u>(500)</u> | <u>(400)</u> |
| Retained earnings | \$600 | \$500 |

$$\text{Basic earning power} = \frac{\text{Earnings before interest and taxes}}{\text{Total assets}}$$

For Fictitious Corporation, for the current year:

$$\text{Basic earning power} = \frac{\$2,000,000}{\$11,000,000} = 0.1818 \text{ or } 18.18\%$$

For every dollar invested in assets, Fictitious earned about 18 cents in the current year. This measure deals with earnings from operations; it does not consider how these operations are financed.

Another return-on-assets ratio uses net income—operating earnings less interest and taxes—instead of earnings before interest and taxes:¹

$$\text{Return on assets} = \frac{\text{Net income}}{\text{Total assets}}$$

¹ In actual application the same term, return on assets, is often used to describe both ratios. It is only in the actual context or through an examination of the numbers themselves that we know which return ratio is presented. We use two different terms to describe these two return-on-asset ratios in this chapter simply to avoid any confusion.

TABLE 9.3 Fictitious Company Statement of Cash Flows, Years Ended December 31, in Thousands

| | Current Year | Prior Year |
|--|------------------|--------------|
| Cash flow from (used for) operating activities | | |
| Net income | \$1,200 | \$1,000 |
| Add or deduct adjustments to cash basis: | | |
| Change in accounts receivables | \$200 | \$(200) |
| Change in accounts payable | 100 | 400 |
| Change in marketable securities | (200) | 200 |
| Change in inventories | (800) | (600) |
| Change in other current liabilities | 300 | 0 |
| Depreciation | <u>1,000</u> | <u>1,000</u> |
| | <u>600</u> | <u>800</u> |
| Cash flow from operations | \$1,800 | \$1,800 |
| Cash flow from (used for) investing activities | | |
| Purchase of plant and equipment | <u>\$(1,000)</u> | <u>\$0</u> |
| Cash flow from (used for) investing activities | \$(1,000) | \$0 |
| Cash flow from (used for) financing activities | | |
| Sale of common stock | \$1,000 | \$0 |
| Repayment of long-term debt | (1,000) | (1,500) |
| Payment of preferred dividends | (100) | (100) |
| Payment of common dividends | <u>(500)</u> | <u>(400)</u> |
| Cash flow from (used for) financing activities | (600) | (1,900) |
| Increase (decrease) in cash flow | \$200 | \$(100) |
| Cash at the beginning of the year | <u>200</u> | <u>300</u> |
| Cash at the end of the year | \$400 | \$200 |

For Fictitious in the current year:

$$\text{Return on assets} = \frac{\$1,200,000}{\$11,000,000} = 0.1091 \text{ or } 10.91\%$$

Thus, without taking into consideration how assets are financed, the return on assets for Fictitious is 18%. Taking into consideration how assets are financed, the return on assets is 11%. The difference is due to Fictitious

financing part of its total assets with debt, incurring interest of \$400,000 in the current year; hence, the return-on-assets ratio excludes taxes of \$400,000 in the current year from earnings in the numerator.

If we look at Fictitious's liabilities and equities, we see that the assets are financed in part by liabilities (\$1 million short term, \$4 million long term) and in part by equity (\$800,000 preferred stock, \$5.2 million common stock). Investors may not be interested in the return the firm gets from its total investment (debt plus equity), but rather shareholders are interested in the return the firm can generate on their investment. The *return on equity* is the ratio of the net income shareholders receive to their equity in the stock:

$$\text{Return on equity} = \frac{\text{Net income}}{\text{Book value of shareholders' equity}}$$

For Fictitious Corporation, there is only one type of shareholder: common. For the current year:

$$\text{Return on equity} = \frac{\$1,200,000}{\$6,000,000} = 0.2000 \text{ or } 20.00\%$$

Recap: Return-on-Investment Ratios

The return-on-investment ratios for Fictitious Corporation for the current year are:

$$\text{Basic earning power} = 18.18\%$$

$$\text{Return on assets} = 10.91\%$$

$$\text{Return on equity} = 20.00\%$$

These return-on-investment ratios indicate:

- Fictitious earns over 18% from operations, or about 11% overall, from its assets.
- Shareholders earn 20% from their investment (measured in book value terms).

These ratios do not provide information on:

- Whether this return is due to the profit margins (that is, due to costs and revenues) or to how efficiently Fictitious uses its assets.
- The return shareholders earn on their actual investment in the firm, that is, what shareholders earn relative to their actual investment, not the book value of their investment. For example, \$100 may be invested in

the stock, but its value according to the balance sheet may be greater than or, more likely, less than \$100.

DuPont System

The returns on investment ratios provide the CFO a “bottom line” on the performance of a company, but do not tell us anything about the “why” behind this performance. For an understanding of the “why,” the CFO must dig a bit deeper into the financial statements. A method that is useful in examining the source of performance is the DuPont system. The *DuPont system* is a method of breaking down return ratios into their components to determine which areas are responsible for a firm’s performance. To see how it is used, let us take a closer look at the first definition of the return on assets:

$$\text{Basic earning power} = \frac{\text{Earnings before interest and taxes}}{\text{Total assets}}$$

Suppose the return on assets changes from 20% in one period to 10% the next period. We do not know whether this decreased return is due to a less efficient use of the firm’s assets—that is, lower activity—or to less effective management of expenses (i.e., lower profit margins). A lower return on assets could be due to lower activity, lower margins, or both. Because the CFO is interested in evaluating past operating performance to evaluate different aspects of the management of the firm and to predict future performance, knowing the source of these returns is valuable.

Let us take a closer look at the return on assets and break it down into its components: measures of activity and profit margin. We do this by relating both the numerator and the denominator to sales activity. Divide both the numerator and the denominator of the basic earning power by revenues:

$$\text{Basic earning power} = \frac{\text{Earnings before interest and taxes/Revenues}}{\text{Revenues total assets/Revenues}}$$

which is equivalent to:

$$\begin{aligned} &\text{Basic earning power} \\ &= \left(\frac{\text{Earnings before interest and taxes}}{\text{Revenues}} \right) \left(\frac{\text{Revenues}}{\text{Revenues total assets}} \right) \end{aligned}$$

This says that the earning power of the company is related to profitability (in this case, operating profit) and a measure of activity (total asset turnover).

$$\text{Basic earning power} = (\text{Operating profit margin})(\text{Total asset turnover})$$

When analyzing a change in the company’s basic earning power, the CFO could look at this breakdown to see the change in its components: operating profit margin and total asset turnover.

This method of analyzing return ratios in terms of profit margin and turnover ratios, referred to as the DuPont System, is credited to the E.I. DuPont Corporation, whose management developed a system of breaking down return ratios into their components.

Let’s look at the return on assets of Fictitious for the two years. Its returns on assets were 20% in the prior year and 18.18% in the current year. We can decompose the firm’s returns on assets for the two years to obtain:

| Year | Basic Earning Power | Operating Profit Margin | Total Asset Turnover |
|---------|---------------------|-------------------------|----------------------|
| Prior | 20.00% | 22.22% | 0.9000 times |
| Current | 18.18 | 20.00 | 0.9091 times |

We see that operating profit margin declined over the two years, yet asset turnover improved slightly, from 0.9000 to 0.9091. Therefore, the return-on-assets decline is attributable to lower profit margins.

The return on assets can be broken down into its components in a similar manner:

$$\text{Return on assets} = \left(\frac{\text{Net income}}{\text{Revenues}} \right) \left(\frac{\text{Revenues}}{\text{Revenues total assets}} \right)$$

or

$$\text{Return on assets} = (\text{Net profit margin})(\text{Total asset turnover})$$

The basic earning power ratio relates to the return on assets. Recognizing that:

$$\text{Net income} = \text{Earnings before tax}(1 - \text{Tax rate})$$

then

$$\begin{aligned} \text{Net income} &= \text{Earnings before interest and taxes} \\ &\times \left(\frac{\text{Earnings before taxes}}{\text{Earnings before interest and taxes}} \right) (1 - \text{Tax rate}) \end{aligned}$$

\uparrow
 equity’s share of earnings

\uparrow
 tax retention %

The ratio of earnings before taxes to earnings before interest and taxes reflects the interest burden of the company, where as the term (1 – tax rate) reflects the company’s tax burden. Therefore,

| Year | Return on Equity | Net Profit Margin | Total Asset Turnover | Total Debt to Assets | Equity Multiplier |
|---------|------------------|-------------------|----------------------|----------------------|-------------------|
| Prior | 22.73% | 11.11% | 0.9000 times | 56.00% | 2.2727 |
| Current | 20.00 | 12.00 | 0.9091 | 45.45% | 1.8332 |

The return on equity decreased over the two years because of a lower operating profit margin and less use of financial leverage.

The CFO can decompose the return on equity further by breaking out the equity's share of before-tax earnings (represented by the ratio of earnings before and after interest) and tax retention percentage. Consider the example in Figure 9.1, in which we provide a DuPont breakdown of the return on equity for Microsoft Corporation for the fiscal year ending June 30, 2006 in Panel A. The return on equity of 31.486% can be broken down into three and then five components, as shown in this figure. We can also use this breakdown to compare the return on equity for the 2005 and 2006 fiscal years, as shown in Panel B. As you can see, the return on equity improved from 2005 to 2006 and, using this breakdown, we can see that this was due primarily to the improvement in the asset turnover and the increased financial leverage.

This decomposition allows the CFO to take a closer look at the factors that are controllable by a company's management (e.g., asset turnover) and those that are not controllable (e.g., tax retention). The breakdowns lead the CFO to information on both the balance sheet and the income statement. And this is not the only breakdown of the return ratios—further decomposition is possible.

LIQUIDITY

Liquidity reflects the ability of a firm to meet its short-term obligations using those assets that are most readily converted into cash. Assets that may be converted into cash in a short period of time are referred to as *liquid assets*; they are listed in financial statements as current assets. Current assets are often referred to as *working capital*, since they represent the resources needed for the day-to-day operations of the firm's long-term capital investments. Current assets are used to satisfy short-term obligations, or current liabilities. The amount by which current assets exceed current liabilities is referred to as the *net working capital*.

Operating Cycle

How much liquidity a firm needs depends on its operating cycle. The *operating cycle* is the duration from the time cash is invested in goods and

FIGURE 9.1 The DuPont System Applied to Microsoft Corporation

For the fiscal year ending June 30, 2006,

$$\text{Return on equity} = \frac{\text{Net income}}{\text{Total assets}} = \frac{\$12.599}{\$40.014} = 0.31486 \text{ or } 31.486\%$$

Breaking return on equity into three components:

$$\begin{aligned} \text{Return on equity} &= \frac{\text{Net income}}{\text{Revenues}} \times \frac{\text{Revenues}}{\text{Total assets}} \times \frac{\text{Total assets}}{\text{Shareholders' equity}} \\ &= \frac{\$12.599}{\$44.282} \times \frac{\$44.282}{\$69.597} \times \frac{\$69.597}{\$40.014} = 0.31486 \text{ or } 31.486\% \end{aligned}$$

Breaking the return on equity into five components:

$$\begin{aligned} \text{Return on equity} &= \left(\frac{\text{Earnings before interest and taxes}}{\text{Revenues}} \right) \times \left(\frac{\text{Earnings before taxes}}{\text{Earnings before interest and taxes}} \right) \times (1 - \text{Tax rate}) \\ &\quad \times \left(\frac{\text{Revenues}}{\text{Total assets}} \right) \times \left(\frac{\text{Total assets}}{\text{Shareholders' equity}} \right) \\ \text{Return on equity} &= \left(\frac{\$18.262}{\$44.282} \right) \times \left(\frac{\$18.262}{\$18.262} \right) \times (1 - 0.31010) \times \left(\frac{\$44.282}{\$69.597} \right) \times \left(\frac{\$69.597}{\$40.014} \right) \\ &= 0.41240 \times 1.0 \times 0.68990 \times 0.63626 \times 1.73932 \\ &= 0.31486 \text{ or } 31.486\% \end{aligned}$$

Comparing the components between the June 30, 2006 fiscal year and the June 30, 2005 fiscal year,

$$\begin{aligned} \text{Return on equity} &= \left(\frac{\text{Earnings before interest and taxes}}{\text{Revenues}} \right) \times \left(\frac{\text{Earnings before taxes}}{\text{Earnings before interest and taxes}} \right) \times (1 - \text{Tax rate}) \\ &\quad \times \left(\frac{\text{Revenues}}{\text{Total assets}} \right) \times \left(\frac{\text{Total assets}}{\text{Shareholders' equity}} \right) \end{aligned}$$

$$\text{Return on equity}_{\text{June 30, 2006}} = 0.41240 \times 1.0 \times 0.68990 \times 0.63626 \times 1.73932 = 31.486\%$$

$$\text{Return on equity}_{\text{June 30, 2005}} = 0.41791 \times 1.0 \times 0.73695 \times 0.56186 \times 1.47179 = 25.468\%$$

services to the time that investment produces cash. For example, a firm that produces and sells goods has an operating cycle comprising four phases:

1. Purchase raw materials and produce goods, investing in inventory.
2. Sell goods, generating sales, which may or may not be for cash.

3. Extend credit, creating accounts receivable.
4. Collect accounts receivable, generating cash.

The four phases make up the cycle of cash use and generation. The operating cycle would be somewhat different for companies that produce services rather than goods, but the idea is the same—the operating cycle is the length of time it takes to *generate* cash through the *investment* of cash.

What does the operating cycle have to do with liquidity? The longer the operating cycle, the more current assets are needed (relative to current liabilities) since it takes longer to convert inventories and receivables into cash. In other words, the longer the operating cycle, the greater the amount of net working capital required.

To measure the length of an operating cycle we need to know:

- The time it takes to convert the investment in inventory into sales (that is, cash → inventory → sales → accounts receivable).
- The time it takes to collect sales on credit (that is, accounts receivable → cash).

We can estimate the operating cycle for Fictitious Corporation for the current year, using the balance sheet and income statement data. The number of days Fictitious ties up funds in inventory is determined by the total amount of money represented in inventory and the average day's cost of goods sold. The current investment in inventory—that is, the money “tied up” in inventory—is the ending balance of inventory on the balance sheet. The *average day's cost of goods sold* is the cost of goods sold on an average day in the year, which can be estimated by dividing the cost of goods sold (which is found on the income statement) by the number of days in the year. The average day's cost of goods sold for the current year is:

$$\begin{aligned} \text{Average day's cost of goods sold} &= \frac{\text{Cost of goods sold}}{365 \text{ days}} \\ &= \frac{\$6,500,000}{365 \text{ days}} = \$17,808 \text{ per day} \end{aligned}$$

In other words, Fictitious incurs, on average, a cost of producing goods sold of \$17,808 per day.

Fictitious has \$1.8 million of inventory on hand at the end of the year. How many days' worth of goods sold is this? One way to look at this is to imagine that Fictitious stopped buying more raw materials and just finished producing whatever was on hand in inventory, using available raw materials and work-in-process. How long would it take Fictitious to run out of inventory?

We compute the days sales in inventory (DSI), also known as the *number of days of inventory*, by calculating the ratio of the amount of inventory on hand (in dollars) to the average day's cost of goods sold (in dollars per day):

$$\begin{aligned} \text{Days sales in inventory} &= \frac{\text{Amount of inventory on hand}}{\text{Average day's cost of goods sold}} \\ &= \frac{\$1,800,000}{\$17,808 \text{ day}} = 101 \text{ days} \end{aligned}$$

In other words, Fictitious has approximately 101 days of goods on hand at the end of the current year. If sales continued at the same price, it would take Fictitious 101 days to run out of inventory.

If the ending inventory is representative of the inventory throughout the year, then it takes about 101 days to convert the investment in inventory into sold goods. Why worry about whether the year-end inventory is representative of inventory at any day throughout the year? Well, if inventory at the end of the fiscal year-end is lower than on any other day of the year, we have understated the DSI. Indeed, in practice most companies try to choose fiscal year-ends that coincide with the slow period of their business. That means the ending balance of inventory would be *lower* than the typical daily inventory of the year. To get a better picture of the firm, we could, for example, look at quarterly financial statements and take averages of quarterly inventory balances. However, here for simplicity we make a note of the problem of representatives and deal with it later in the discussion of financial ratios.²

We can extend the same logic for calculating the number of days between a sale—when an account receivable is created—and the time it is collected in cash. If we assume that Fictitious sells all goods on credit, we can first calculate the *average credit sales per day* and then figure out how many days' worth of credit sales are represented by the ending balance of receivables.

The average credit sales per day are:

$$\text{Credit sales per day} = \frac{\text{Credit sales}}{365 \text{ days}} = \frac{\$10,000,000}{365 \text{ days}} = \$27,397 \text{ per day}$$

Therefore, Fictitious generates \$27,397 of credit sales per day. With an ending balance of accounts receivable of \$600,000, the *days sales outstanding (DSO)*, also known as the *number of days of credit*, in this ending bal-

² As an attempt to make the inventory figure more representative, some suggest taking the average of the beginning and ending inventory amounts. This does nothing to remedy the representativeness problem because the beginning inventory is simply the ending inventory from the previous year and, like the ending value from the current year, is measured at the low point of the operating cycle. A preferred method, if data is available, is to calculate the average inventory for the four quarters of the fiscal year.

ance is calculated by taking the ratio of the balance in the accounts receivable account to the credit sales per day:

$$\begin{aligned}\text{Number of days of credit} &= \frac{\text{Accounts receivable}}{\text{Credit sales per day}} \\ &= \frac{\$600,000}{\$27,297 \text{ per day}} = 22 \text{ days}\end{aligned}$$

If the ending balance of receivables at the end of the year is representative of the receivables on any day throughout the year, then it takes, on average, approximately 22 days to collect the accounts receivable. In other words, it takes 22 days for a sale to become cash.

Using what we have determined for the inventory cycle and cash cycle, we see that for Fictitious:

$$\begin{aligned}\text{Operating cycle} &= \text{DSI} + \text{DSO} \\ &= 101 \text{ days} + 22 \text{ days} = 123 \text{ days}\end{aligned}$$

We also need to look at the liabilities on the balance sheet to see how long it takes a firm to pay its short-term obligations. We can apply the same logic to accounts payable as we did to accounts receivable and inventories. How long does it take a firm, on average, to go from creating a payable (buying on credit) to paying for it in cash?

First, we need to determine the amount of an *average day's purchases on credit*. If we assume all the Fictitious purchases are made on credit, then the total purchases for the year would be the cost of goods sold less any amounts included in cost of goods sold that are not purchases. For example, depreciation is included in the cost of goods sold yet is not a purchase. Since we do not have a breakdown on the company's cost of goods sold showing how much was paid for in cash and how much was on credit, let us assume for simplicity that purchases are equal to cost of goods sold less depreciation. The average day's purchases then become:

$$\begin{aligned}\text{Average day's purchases} &= \frac{\text{Cost of goods sold} - \text{Depreciation}}{365 \text{ days}} \\ &= \frac{\$6,500,000 - \$1,000,000}{365 \text{ days}} = \$15,068 \text{ per day}\end{aligned}$$

The *days payables outstanding (DPO)*, also known as the number of days of purchases, represented in the ending balance in accounts payable is calculated as the ratio of the balance in the accounts payable account to the average day's purchases:

$$\text{Days payables outstanding} = \frac{\text{Accounts payable}}{\text{Average day's purchases}}$$

For Fictitious in the current year:

$$\text{Days payables outstanding} = \frac{\$500,000}{\$15,065 \text{ per day}} = 33 \text{ days}$$

This means that on average Fictitious takes 33 days to pay out cash for a purchase.

The operating cycle tells us how long it takes to convert an investment in cash *back into* cash (by way of inventory and accounts receivable). The number of days of payables tells us how long it takes to pay on purchases made to create the inventory. If we put these two pieces of information together, we can see how long, on net, we tie up cash. The difference between the operating cycle and the number of days of purchases is the *cash conversion cycle (CCC)*, also known as the *net operating cycle*:

$$\text{Cash conversion cycle} = \text{Operating cycle} - \text{Number of days of payables}$$

Or, substituting for the operating cycle,

$$\text{CCC} = \text{DSI} + \text{DSO} + \text{DPO}$$

The cash conversion cycle for Fictitious in the current year is:

$$\text{CCC} = 101 + 22 - 33 = 90 \text{ days}$$

The CCC is how long it takes for the firm to get cash back from its investments in inventory and accounts receivable, considering that purchases may be made on credit. By not paying for purchases immediately (that is, using trade credit), the firm reduces its liquidity needs. Therefore, the longer the net operating cycle, the greater the required liquidity.

Measures of Liquidity

The CFO can describe a firm's ability to meet its current obligations in several ways. The *current ratio* indicates the firm's ability to meet or cover its current liabilities using its current assets:

$$\text{Current ratio} = \frac{\text{Current assets}}{\text{Current liabilities}}$$

For the Fictitious Corporation, the current ratio for the current year is the ratio of current assets, \$3 million, to current liabilities, the sum of accounts payable and other current liabilities, or \$1 million.

$$\text{Current ratio} = \frac{\$3,000,000}{\$1,000,000} = 3.0 \text{ times}$$

The current ratio of 3.0 indicates that Fictitious has three times as much as it needs to cover its current obligations during the year. However, the current ratio groups all current asset accounts together, assuming they are all as easily converted to cash. Even though, by definition, current assets can be transformed into cash within a year, not all current assets can be transformed into cash in a short period of time.

An alternative to the current ratio is the *quick ratio*, also called the *acid-test ratio*, which uses a slightly different set of current accounts to cover the same current liabilities as in the current ratio. In the quick ratio, the least liquid of the current asset accounts, inventory, is excluded. Hence:

$$\text{Quick ratio} = \frac{\text{Current assets} - \text{Inventory}}{\text{Current liabilities}}$$

We typically leave out inventories in the quick ratio because inventories are generally perceived as the least liquid of the current assets. By leaving out the least liquid asset, the quick ratio provides a more conservative view of liquidity.

For Fictitious in the current year:

$$\text{Quick ratio} = \frac{\$3,000,000 - 1,800,000}{\$1,000,000} = \frac{\$1,200,000}{\$1,000,000} = 1.2 \text{ times}$$

Still another way to measure the firm's ability to satisfy short-term obligations is the *net working capital-to-sales ratio*, which compares net working capital (current assets less current liabilities) with sales:

$$\text{Net working capital-to-sales ratio} = \frac{\text{Net working capital}}{\text{Sales}}$$

This ratio tells us the “cushion” available to meet short-term obligations relative to sales. Consider two firms with identical working capital of \$100,000, but one has sales of \$500,000 and the other sales of \$1,000,000. If they have identical operating cycles, this means that the firm with the greater sales has more funds flowing in and out of its current asset investments (inventories and receivables). The company with more funds flowing in and out needs a larger cushion to protect itself in case of a disruption in the cycle, such as a labor strike or unexpected delays in customer payments.

The longer the operating cycle, the more of a cushion (net working capital) a firm needs for a given level of sales.

For Fictitious Corporation:

$$\begin{aligned}\text{Net working capital-to-sales ratio} &= \frac{\$3,000,000 - 1,000,000}{\$10,000,000} \\ &= 0.2000 \text{ or } 20\%\end{aligned}$$

The ratio of 0.20 tells us that for every dollar of sales, Fictitious has 20 cents of net working capital to support it.

Recap: Liquidity Ratios

Operating cycle and liquidity ratio information for Fictitious using data for the current year, in summary, is:

| | |
|------------------------------------|------------|
| Days sales in inventory | = 101 days |
| Days sales outstanding | = 22 days |
| Operating cycle | = 123 days |
| Days payables outstanding | = 33 days |
| Cash conversion cycle | = 90 days |
| Current ratio | = 3.0 |
| Quick ratio | = 1.2 |
| Net working capital-to-sales ratio | = 20% |

Given the measures of time related to the current accounts—the operating cycle and the cash conversion cycle—and the three measures of liquidity—current ratio, quick ratio, and net working capital-to-sales ratio—we know the following about Fictitious Corporation’s ability to meet its short-term obligations:

- Inventory is less liquid than accounts receivable (comparing days of inventory with days of credit).
- Current assets are greater than needed to satisfy current liabilities in a year (from the current ratio).
- The quick ratio tells us that Fictitious can meet its short-term obligations even without resorting to selling inventory.
- The net working capital “cushion” is 20 cents for every dollar of sales (from the net working capital-to-sales ratio.)

What don't ratios tell us about liquidity? They don't provide us with answers to the following questions:

- How liquid are the accounts receivable? How much of the accounts receivable will be collectible? Whereas we know it takes, on average, 22 days to collect, we do not know how much will never be collected.
- What is the nature of the current liabilities? How much of current liabilities consists of items that recur (such as accounts payable and wages payable) each period and how much consists of occasional items (such as income taxes payable)?
- Are there any unrecorded liabilities (such as operating leases) that are not included in current liabilities?

PROFITABILITY RATIOS

Liquidity ratios indicate a firm's ability to meet its immediate obligations. Now we extend the analysis by adding profitability ratios, which help the CFO gauge how well a firm is managing its expenses. *Profit margin ratios* compare components of income with sales. They give the CFO an idea of which factors make up a firm's income and are usually expressed as a portion of each dollar of sales. For example, the profit margin ratios we discuss here differ only in the numerator. It is in the numerator that we can evaluate performance for different aspects of the business.

For example, suppose the CFO wants to evaluate how well production facilities are managed. The analyst would focus on gross profit (sales less cost of goods sold), a measure of income that is the direct result of production management. Comparing gross profit with sales produces the *gross profit margin*:

$$\text{Gross profit margin} = \frac{\text{Revenues} - \text{Cost of goods sold}}{\text{Revenues}}$$

This ratio tells us the portion of each dollar of sales that remains after deducting production expenses. For Fictitious Corporation for the current year:

$$\begin{aligned}\text{Gross profit margin} &= \frac{\$10,000,000 - \$6,500,000}{\$10,000,000} = \frac{\$3,500,000}{\$10,000,000} \\ &= 0.3500 \text{ or } 35\%\end{aligned}$$

For each dollar of revenues, the firm's gross profit is 35 cents. Looking at sales and cost of goods sold, we can see that the gross profit margin is affected by:

- Changes in sales volume, which affect cost of goods sold and sales.
- Changes in sales price, which affect revenues.
- Changes in the cost of production, which affect cost of goods sold.

Any change in gross profit margin from one period to the next is caused by one or more of those three factors. Similarly, differences in gross margin ratios among firms are the result of differences in those factors.

To evaluate operating performance, we need to consider operating expenses in addition to the cost of goods sold. To do this, remove operating expenses (e.g., selling and general administrative expenses) from gross profit, leaving operating profit, also referred to as earnings before interest and taxes (EBIT). The *operating profit margin* is therefore:

$$\begin{aligned} \text{Operating profit margin} &= \frac{\text{Revenues} - \text{Cost of goods sold} - \text{Operating expenses}}{\text{Revenues}} \\ &= \frac{\text{Revenues earnings before interest and taxes}}{\text{Revenues}} \end{aligned}$$

For Fictitious in the current year:

$$\text{Operating profit margin} = \frac{\$2,000,000}{\$10,000,000} = 0.20 \text{ or } 20\%$$

Therefore, for each dollar of revenues, Fictitious has 20 cents of operating income. The operating profit margin is affected by the same factors as gross profit margin, plus operating expenses such as:

- Office rent and lease expenses.
- Miscellaneous income (for example, income from investments).
- Advertising expenditures.
- Bad debt expense.

Most of these expenses are related in some way to revenues, though they are not included directly in the cost of goods sold. Therefore, the difference between the gross profit margin and the operating profit margin is due to these indirect items that are included in computing the operating profit margin.

Both the gross profit margin and the operating profit margin reflect a company's operating performance. But they do not consider how these operations have been financed. To evaluate both operating and financing decisions, the CFO must compare net income (that is, earnings after deducting interest and taxes) with revenues. The result is the net profit margin:

$$\text{Net profit margin} = \frac{\text{Net income}}{\text{Revenues}}$$

The net profit margin tells the CFO the net income generated from each dollar of revenues; it considers financing costs that the operating profit margin does not consider. For Fictitious for the current year:

$$\text{Net profit margin} = \frac{\$1,200,000}{\$10,000,000} = 0.12 \text{ or } 12\%$$

For every dollar of revenues, Fictitious generates 12 cents in profits.

Recap: Profitability Ratios

The profitability ratios for Fictitious in the current year are:

Gross profit margin = 35%

Operating profit margin = 20%

Net profit margin = 12%

They indicate the following about the operating performance of Fictitious:

- Each dollar of revenues contributes 35 cents to gross profit and 20 cents to operating profit.
- Every dollar of revenues contributes 12 cents to owners' earnings.
- By comparing the 20-cent operating profit margin with the 12-cent net profit margin, we see that Fictitious has 8 cents of financing costs for every dollar of revenues.

What these ratios do not indicate about profitability is the sensitivity of gross, operating, and net profit margins to:

- Changes in the sales price.
- Changes in the volume of sales.

Looking at the profitability ratios for one firm for one period gives the CFO very little information that can be used to make judgments regarding future profitability. Nor do these ratios provide the CFO any information about why current profitability is what it is. We need more information to make these kinds of judgments, particularly regarding the future profitability of the firm. For that, turn to activity ratios, which are measures of how well assets are being used.

ACTIVITY RATIOS

Activity ratios—for the most part, turnover ratios—can be used to evaluate the benefits produced by specific assets, such as inventory or accounts receivable, or to evaluate the benefits produced by the totality of the firm's assets.

Inventory Management

The *inventory turnover ratio* indicates how quickly a firm has used inventory to generate the goods and services that are sold. The inventory turnover is the ratio of the cost of goods sold to inventory:³

$$\text{Inventory turnover ratio} = \frac{\text{Cost of goods sold}}{\text{Inventory}}$$

For Fictitious for the current year:

$$\text{Inventory turnover ratio} = \frac{\$6,500,000}{\$1,800,000} = 3.61 \text{ times}$$

This ratio indicates that Fictitious turns over its inventory 3.61 times per year. On average, cash is invested in inventory, goods and services are produced, and these goods and services are sold 3.6 times a year. Looking back to the number of days of inventory, we see that this turnover measure is consistent with the results of that calculation: There are 101 calendar days of inventory on hand at the end of the year; dividing 365 days by 101 days, or 365/101 days, we find that inventory cycles through (from cash to sales) 3.61 times a year.

Accounts Receivable Management

In much the same way the CFO can evaluate inventory turnover, the CFO can evaluate a firm's management of its accounts receivable and its credit policy. The *accounts receivable turnover ratio* is a measure of how effectively a firm is using credit extended to customers. The reason for extending credit is to increase sales. The downside to extending credit is the possibility of default—customers not paying when promised. The benefit obtained from extending credit is referred to as *net credit sales*—sales on credit less returns and refunds.

³ A common alternative to this is the ratio of sales to inventory. But there is a problem with this alternative: The numerator is in terms of sales (based on selling prices), whereas the denominator is in terms of costs. By including the sales price in the numerator, the result is not easily interpreted.

$$\text{Accounts receivable turnover} = \frac{\text{Net credit sales}}{\text{Accounts receivable}}$$

Looking at the Fictitious Corporation income statement, we see an entry for sales, but we do not know how much of the amount stated is on credit. In the case of evaluating a firm, the CFO would have an estimate of the amount of credit sales. Let us assume that the entire sales amount represents net credit sales. For Fictitious for the current year:

$$\text{Accounts receivable turnover} = \frac{\$10,000,000}{\$600,000} = 16.67 \text{ times}$$

Therefore, almost 17 times in the year there is, on average, a cycle that begins with a sale on credit and finishes with the receipt of cash for that sale. In other words, there are 17 cycles of sales to credit to cash during the year.

The number of times accounts receivable cycle through the year is consistent with the days sales outstanding (22) that we calculated earlier—accounts receivable turn over 17 times during the year, and the average number of days of sales in the accounts receivable balance is $365 \text{ days} / 16.67 \text{ times} = 22 \text{ days}$.

Overall Asset Management

The inventory and accounts receivable turnover ratios reflect the benefits obtained from the use of specific assets (inventory and accounts receivable). For a more general picture of the productivity of the firm, the CFO can compare the sales during a period with the total assets that generated these revenues.

One way is with the *total asset turnover ratio*, which indicates how many times during the year the value of a firm's total assets is generated in revenues:

$$\text{Total assets turnover} = \frac{\text{Revenues}}{\text{Total assets}}$$

For Fictitious in the current year:

$$\text{Total assets turnover} = \frac{\$10,000,000}{\$11,000,000} = 0.91 \text{ times}$$

The turnover ratio of 0.91 indicated that in the current year, every dollar invested in total assets generates 91 cents of sales. Or, stated differently, the total assets of Fictitious turn over almost once during the year. Because total assets include both tangible and intangible assets, this turnover indicates how efficiently all assets were used.

An alternative is to focus only on fixed assets, the long-term, tangible assets of the firm. The *fixed asset turnover* is the ratio of revenues to fixed assets:

$$\text{Fixed asset turnover ratio} = \frac{\text{Revenues}}{\text{Fixed assets}}$$

For Fictitious in the current year:

$$\text{Fixed asset turnover ratio} = \frac{\$10,000,000}{\$7,000,000} = 1.43 \text{ times}$$

Therefore, for every dollar of fixed assets, Fictitious is able to generate \$1.43 of revenues.

Recap: Activity Ratios

The activity ratios for Fictitious Corporation are:

| | |
|------------------------------------|---------------|
| Inventory turnover ratio | = 3.61 times |
| Accounts receivable turnover ratio | = 16.67 times |
| Total asset turnover ratio | = 0.91 times |
| Fixed asset turnover ratio | = 1.43 times |

From these ratios the CFO can determine that:

- Inventory flows in and out almost four times a year (from the inventory turnover ratio).
- Accounts receivable are collected in cash, on average, 22 days after a sale (from the number of days of credit). In other words, accounts receivable flow in and out almost 17 times during the year (from the accounts receivable turnover ratio).

Here is what these ratios do not indicate about the firm's use of its assets:

- The sales not made because credit policies are too stringent.
- How much of credit sales is not collectible.
- Which assets contribute most to the turnover.

FINANCIAL LEVERAGE RATIOS

A firm can finance its assets with equity or with debt. Financing with debt legally obligates the firm to pay interest and to repay the principal as promised.

Equity financing does not obligate the firm to pay anything because dividends are paid at the discretion of the board of directors. There is always some risk, which we refer to as business risk, inherent in any business enterprise. But how a firm chooses to finance its operations—the particular mix of debt and equity—may add financial risk on top of business risk. *Financial risk* is risk associated with a firm's ability to satisfy its debt obligations, and is often measured using the extent to which debt financing is used relative to equity.

Financial leverage ratios are used to assess how much financial risk the firm has taken on. There are two types of financial leverage ratios: component percentages and coverage ratios. Component percentages compare a firm's debt with either its total capital (debt plus equity) or its equity capital. Coverage ratios reflect a firm's ability to satisfy fixed financing obligations, such as interest, principal repayment, or lease payments.

Component Percentage Ratios

A ratio that indicates the proportion of assets financed with debt is the *debt-to-assets ratio*, which compares total liabilities (short-term + long-term debt) with total assets:

$$\text{Total debt-to-assets ratio} = \frac{\text{Debt}}{\text{Total assets}}$$

For Fictitious in the current year:

$$\text{Total debt-to-assets ratio} = \frac{\$5,000,000}{\$11,000,000} = 0.4546 \text{ or } 45.46\%$$

This ratio indicates that 45% of the firm's assets are financed with debt (both short term and long term).

Another way to look at the financial risk is in terms of the use of debt relative to the use of equity. The debt-to-equity ratio indicates how the firm finances its operations with debt relative to the book value of its shareholders' equity:

$$\text{Debt-to-equity ratio} = \frac{\text{Debt}}{\text{Book value of shareholders' equity}}$$

For Fictitious for the current year, using the book-value definition:

$$\text{Debt-to-equity ratio} = \frac{\$5,000,000}{\$6,000,000} = 0.8333 \text{ or } 83.33\%$$

For every one dollar of book value of shareholders' equity, Fictitious uses 83 cents of debt.

Both of these ratios can be stated in terms of total debt, as above, or in terms of long-term debt or even simply interest-bearing debt. And it is not always clear in which form—total, long-term debt, or interest-bearing—the ratio is calculated. Additionally, it is often the case that the current portion of long-term debt is excluded in the calculation of the long-term versions of these debt ratios.

Book Value versus Market Value

One problem with using a financial ratio based on the book value of equity to analyze financial risk is that there is seldom a strong relationship between the book value and market value of a stock. The distortion in values on the balance sheet is obvious by looking at the book value of equity and comparing it with the market value of equity. The book value of equity consists of:

- The proceeds to the firm of all the stock issues since it was first incorporated, less any stock repurchased by the firm.
- The accumulative earnings of the firm, less any dividends, since it was first incorporated.

Let's look at an example of the book value versus the market value of equity. IBM was incorporated in 1911, so the book value of its equity represents the sum of all its stock issued and all its earnings, less any dividends paid since 1911. As of the end of 2005, IBM's book value was approximately \$33 billion, yet its market value was \$122 billion.

Book value generally does not give a true picture of the investment of shareholders in the firm because:

- Earnings are recorded according to accounting principles, which may not reflect the true economics of transactions.
- Due to inflation, the earnings and proceeds from stock issued in the past do not reflect today's values.

Market value, on the other hand, is the value of equity as perceived by investors. It is what investors are willing to pay. So why bother with book value? For two reasons: First, it is easier to obtain the book value than the market value of a firm's securities, and second, many financial services report ratios using book value rather than market value.

However, any of the ratios presented in this chapter that use the book value of equity can be restated using the market value of equity. For example, instead of using the book value of equity in the debt-to-equity ratio, the market value of equity to measure the firm's financial leverage can be used.

Coverage Ratios

The ratios that compare debt to equity or debt to assets indicate the amount of financial leverage, which enables the CFO to assess the financial condition of a firm. Another way of looking at the financial condition and the amount of financial leverage used by the firm is to see how well it can handle the financial burdens associated with its debt or other fixed commitments.

One measure of a firm's ability to handle financial burdens is the *interest coverage ratio*, also referred to as the times *interest-covered ratio*. This ratio tells us how well the firm can cover or meet the interest payments associated with debt. The ratio compares the funds available to pay interest (that is, earnings before interest and taxes) with the interest expense:

$$\text{Interest coverage ratio} = \frac{\text{EBIT}}{\text{Interest expense}}$$

The greater the interest coverage ratio, the better able the firm is to pay its interest expense. For Fictitious for the current year:

$$\text{Interest coverage ratio} = \frac{\$2,000,000}{\$400,000} = 5 \text{ times}$$

An interest coverage ratio of 5 means that the firm's earnings before interest and taxes are five times greater than its interest payments.

The interest coverage ratio provides information about a firm's ability to cover the interest related to its debt financing. However, there are other costs that do not arise from debt but that nevertheless must be considered in the same way we consider the cost of debt in a firm's financial obligations. For example, lease payments are fixed costs incurred in financing operations. Like interest payments, they represent legal obligations.

What funds are available to pay debt and debt-like expenses? Start with EBIT and *add back* expenses that were deducted to arrive at EBIT. The ability of a firm to satisfy its fixed financial costs—its fixed charges—is referred to as the *fixed charge coverage ratio*. One definition of the fixed charge coverage considers only the lease payments:

$$\text{Fixed charge coverage ratio} = \frac{\text{EBIT} + \text{Lease expense}}{\text{Interest} + \text{Lease expense}}$$

For Fictitious for the current year:

$$\text{Fixed charge coverage ratio} = \frac{\$2,000,000 + \$1,000,000}{\$400,000 + \$1,000,000} = 2.14 \text{ times}$$

This ratio tells us that Fictitious's earnings can cover its fixed charges (interest and lease payments) more than two times over.

What fixed charges to consider is not entirely clear-cut. For example, if the firm is required to set aside funds to eventually or periodically retire debt—referred to as *sinking funds*—is the amount set aside a fixed charge? As another example, since preferred dividends represent a fixed financing charge, should they be included as a fixed charge? From the perspective of the common shareholder, the preferred dividends must be covered either to enable the payment of common dividends or to retain earnings for future growth. Because debt principal repayment and preferred stock dividends are paid on an after-tax basis—paid out of dollars remaining after taxes are paid—this fixed charge must be converted to before-tax dollars. The fixed charge coverage ratio can be expanded to accommodate the sinking funds and preferred stock dividends as fixed charges.

Up to now we considered earnings before interest and taxes as funds available to meet fixed financial charges. EBIT includes noncash items such as depreciation and amortization. If the CFO is trying to compare funds available to meet obligations, a better measure of available funds is cash flow from operations, as reported in the statement of cash flows. A ratio that considers cash flows from operations as funds available to cover interest payments is referred to as the *cash flow interest coverage ratio*.

$$\begin{aligned} &\text{Cash flow interest coverage ratio} \\ &= \frac{\text{Cash flow from operations} + \text{Interest} + \text{Taxes}}{\text{Interest}} \end{aligned}$$

The amount of cash flow from operations that is in the statement of cash flows is net of interest and taxes. So we have to add back interest and taxes to cash flow from operations to arrive at the cash flow amount before interest and taxes in order to determine the cash flow available to cover interest payments.

For Fictitious for the current year:

$$\begin{aligned} \text{Cash flow interest coverage ratio} &= \frac{\$1,800,000 + \$400,000 + \$400,000}{\$400,000} \\ &= \frac{\$2,600,000}{\$400,000} = 6.5 \text{ times} \end{aligned}$$

This coverage ratio indicates that, in terms of cash flows, Fictitious has 6.5 times more cash than is needed to pay its interest. This is a better picture of interest coverage than the five times reflected by EBIT. Why the difference? Because cash flow considers not just the accounting income, but non-cash items as well. In the case of Fictitious, depreciation is a noncash charge

that reduced EBIT but not cash flow from operations—it is added back to net income to arrive at cash flow from operations.

Recap: Financial Leverage Ratios

Summarizing, the financial leverage ratios for Fictitious Corporation for the current year are:

| | | |
|-----------------------------------|---|------------|
| Debt-to-assets ratio | = | 45.45% |
| Debt-to-equity ratio | = | 83.33% |
| Interest coverage ratio | = | 5.00 times |
| Fixed charge coverage ratio | = | 2.14 times |
| Cash flow interest coverage ratio | = | 6.50 times |

These ratios indicate that Fictitious uses its financial leverage as follows:

- Assets are 45% financed with debt, measured using book values.
- Long-term debt is approximately two-thirds of equity. When equity is measured in market value terms, long-term debt is approximately one-sixth of equity.

These ratios do not indicate:

- What other fixed, legal commitments the firm has that are not included on the balance sheet (for example, operating leases).
- What the intentions of management are regarding taking on more debt as the existing debt matures.

COMMON-SIZE ANALYSIS

The CFO can evaluate a company's operating performance and financial condition through ratios that relate various items of information contained in the financial statements. Another way to analyze a firm is to look at its financial data more comprehensively.

Common-size analysis is a method of analysis in which the components of a financial statement are compared with each other. The first step in common-size analysis is to break down a financial statement—either the balance sheet or the income statement—into its parts. The next step is to calculate the proportion that each item represents relative to some benchmark. This form of common-size analysis is sometimes referred to as *vertical common-*

size analysis. Another form of common-size analysis is *horizontal common-size analysis*, which uses either an income statement or a balance sheet in a fiscal year and compares accounts to the corresponding items in another year. In common-size analysis of the balance sheet, the benchmark is total assets. For the income statement, the benchmark is sales.

Let us see how it works by doing some common-size financial analysis for the Fictitious Corporation. The company's balance sheet is restated in Table 9.4. This statement does not look precisely like the balance sheet we have seen before. Nevertheless, the data are the same but reorganized. Each item in the original balance sheet has been restated as a proportion of total assets for the purpose of common size analysis. Hence, we refer to this as the *common-size balance sheet*.

In this balance sheet, we see, for example, that in the current year cash is 3.6% of total assets, or $\$400,000/\$11,000,000 = 0.036$. The largest investment is in plant and equipment, which comprises 63.6% of total assets. On the liabilities side, that current liabilities are a small portion (9.1%) of liabilities and equity.

The common-size balance sheet indicates in very general terms how Fictitious has raised capital and where this capital has been invested. As with financial ratios, however, the picture is not complete until trends are examined and compared with those of other firms in the same industry.

In the income statement, as with the balance sheet, the items may be restated as a proportion of sales; this statement is referred to as the *common-size income statement*. The common-size income statements for Fictitious for the two years are shown in Table 9.5. For the current year, the major costs are associated with goods sold (65%); lease expense, other expenses, interest, taxes, and dividends make up smaller portions of sales. Looking at gross profit, EBIT, and net income, these proportions are the profit margins we calculated earlier. The common-size income statement provides information on the profitability of different aspects of the firm's business. Again, the picture is not yet complete. For a more complete picture, the CFO must look at trends over time and make comparisons with other companies in the same industry.

USING FINANCIAL RATIO ANALYSIS

Financial analysis provides information concerning a firm's operating performance and financial condition. This information is useful for the CFO in evaluating the performance of the company as a whole, as well as of divisions, products, and subsidiaries. The CFO must also be aware that fi-

TABLE 9.4 Fictitious Corporation Common-Size Balance Sheets for Years Ending December 31

| | Current Year | Prior Year |
|--|--------------|--------------|
| Asset Components | | |
| Cash | 3.6% | 2.0% |
| Marketable securities | 1.8% | 0.0% |
| Accounts receivable | <u>5.5%</u> | <u>8.0%</u> |
| Inventory | 16.4% | 10.0% |
| Current assets | 27.3% | 20.0% |
| Net plant and equipment | 63.5% | 70.0% |
| Intangible assets | <u>9.2%</u> | <u>10.0%</u> |
| Total assets | 100.0% | 100.0% |
| Liability and shareholders' equity components | | |
| Accounts payable | 4.6% | 4.0% |
| Other current liabilities | 4.6% | 1.0% |
| Long-term debt | <u>36.4%</u> | <u>50.0%</u> |
| Total liabilities | 45.4% | 56.0% |
| Shareholders' equity | <u>54.6%</u> | <u>44.0%</u> |
| Total liabilities and shareholders' equity | 100.0% | 100.0% |

TABLE 9.5 Fictitious Corporation Common-Size Income Statement for Years Ending December 31

| | Current Year | Prior Year |
|------------------------------------|--------------|--------------|
| Sales | 100.0% | 100.0% |
| Cost of goods sold | <u>65.0%</u> | <u>66.7%</u> |
| Gross profit | 35.0% | 33.3% |
| Lease and administrative expenses | <u>15.0%</u> | <u>16.7%</u> |
| Earnings before interest and taxes | 20.0% | 16.7% |
| Interest expense | <u>4.0%</u> | <u>5.6%</u> |
| Earnings before taxes | 16.0% | 16.7% |
| Taxes | <u>4.0%</u> | <u>5.7%</u> |
| Net income | 12.0% | 11.1% |
| Common dividends | <u>6.0%</u> | <u>5.6%</u> |
| Retained earnings | 6.0% | 5.5% |

financial analysis is also used by analysts and investors to gauge the financial performance of the company.

But financial ratio analysis cannot tell the whole story and must be interpreted and used with care. Financial ratios are useful but, as noted in the discussion of each ratio, there is information that the ratios do not reveal. For example, in calculating inventory turnover, we need to assume that the inventory shown on the balance sheet is representative of inventory throughout the year. Another example is in the calculation of accounts receivable turnover. We assumed that all sales were on credit. If we are on the outside looking in—that is, evaluating a firm based on its financial statements only, such as the case of a financial analyst or investor—and therefore do not have data on credit sales, assumptions must be made that may or may not be correct.

In addition, there are other areas of concern that a CFO should be aware of in using financial ratios:

- Limitations in the accounting data used to construct the ratios.
- Selection of an appropriate benchmark firm or firms for comparison purposes.
- Interpretation of the ratios.
- Pitfalls in forecasting future operating performance and financial condition based on past trends.

ILLUSTRATION: PFIZER, INC., 1990–2005

Applied to a fictitious company, the ratio calculations are rather straightforward: form a ratio of two items derived from the financial statements and crunch the numbers. However, it is usually not as straightforward when applying these tools to an actual company.

A thorough analysis of a company requires more space than we can allow here, but we present the basic financial ratio analysis and common-size analysis, and then discuss the several issues in this context that the CFO may want to consider. We'll use Pfizer, Inc., as an example, using published annual financial data for the 16 fiscal years of 1990 through 2005.

Company Description, Industry, and Major Factors

The Pfizer, Inc. Company is a drug manufacturer that has a wide range prescription and consumer health-care products. There are many ways to classify this company with respect to its industry because Pfizer operates

in three business segments: pharmaceuticals, consumer health, and animal health.⁴

Pfizer, Inc., is the largest drug company worldwide. Using one classification of the industry, Pfizer, Inc., has approximately 22% of the market share, with revenues in 2005 over \$51 billion.⁵ Its major competitors are GlaxoSmithKline PLC, Novartis AG, and Merck & Co., as shown in the breakdown of the market shares held by a sampling of drug companies in Figure 9.2. The U.S. drug industry has a few very large companies, such as Pfizer and Merck & Co., but it also has many small, narrowly focused companies, such as those in biotech research (for example ImClone and BioGen).

The drug industry is a noncyclical industry, which means its sales and earnings are not affected significantly by the health of the general economy.

FIGURE 9.2 U.S. Drug Industry, 2005

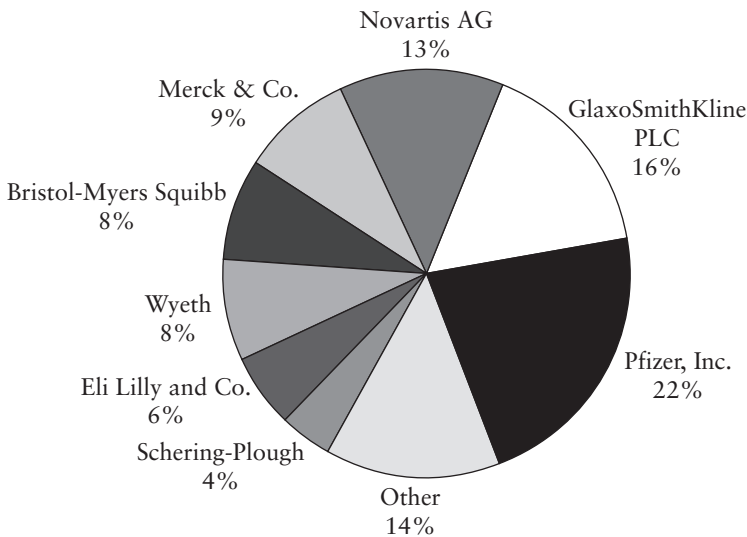

Source: Value Line Investment Survey, January 19, 2006.

⁴ Based on its primary line of business of pharmaceutical manufacturing, its Standard Industrial Code (SIC) is 2834; its North American Industry Classification System (NAICS) code is 325412 (pharmaceutical preparation—manufacturing).

⁵ This classification is based on that of Value Line Investment Survey, 2006. Using classifications of other financial services, such as by Mergent or Yahoo! Finance, there is a slightly different definition of Pfizer's Industry. For example Yahoo! Finance includes companies such as Abbott Laboratories and Bayer AG in the same industry.

FIGURE 9.3 Seasonality in Pfizer, Inc.'s Sales: First Quarter 2002 through Fourth Quarter 2005

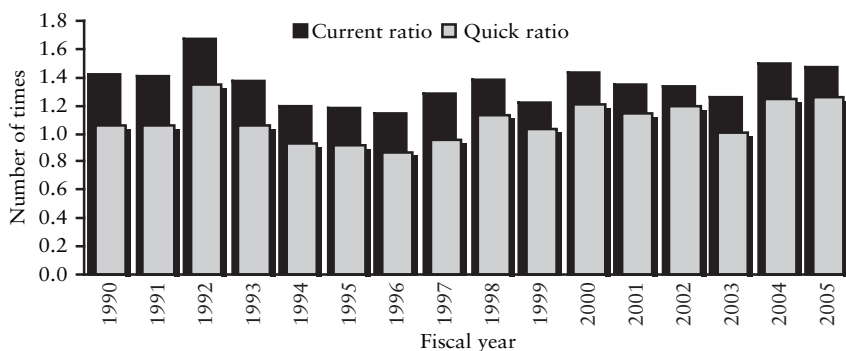

The drug industry's growth is dependent on demographics (e.g., the aging baby boomers) and the incidence of chronic diseases. Research and development is key to a company's growth in this industry. In addition, the industry is affected by government regulation, including drug approvals by the Federal Drug Administration. There is some degree of seasonality in Pfizer's revenues, as we show in Figure 9.3, with the peak of the seasonality in the fourth quarter of each year. This seasonality will affect financial ratios calculated using year-end account balances, such as inventory turnover, days sales outstanding, and the current ratio.

Financial Ratios

Liquidity

The current and quick ratios follow similar trends during the 1990–2005 period, with a dropoff in these ratios in the years 1994–1997 (see Figure 9.4). A look at management's discussion of the financial results in that period indicates that this dropoff is primarily the result of a repayment of long-term debt and an increase in investment expenditures. Other significant events include acquisitions that especially affected 2000–2005 accounts.

In the case of Pfizer, the investment in inventory is small relative to its other assets; drug companies in general do not tend to have large inventories because a large part of their cost of sales is not represented in physical inventory, but rather is the drug patents that result from the research and development activity. Therefore, there is little difference in the graph of the current ratio and the quick ratio in this case. In companies with signifi-

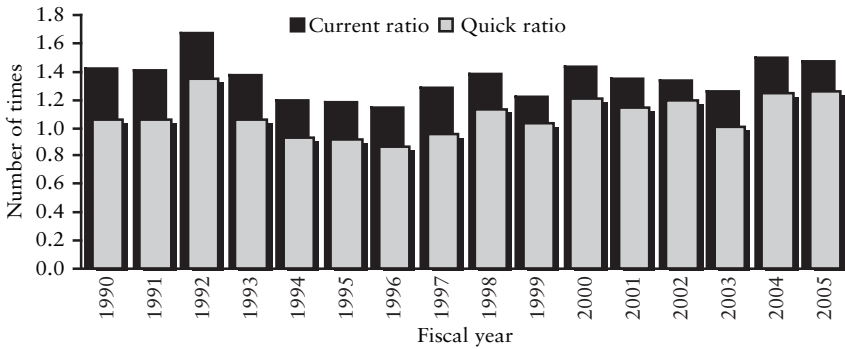
FIGURE 9.4 Liquidity Ratios of Pfizer, Inc., 1990–2005

Source of data: The Pfizer, Inc. Company annual reports, various years.

cant investment in inventory, such as a retailer, a change in the relationship between the current and quick ratio may indicate a change in inventory management.

Activity

We provide the turnover ratios for Pfizer for the 1990–2005 period in Figure 9.5. The dropoff in turnover in the year 2002–2004 is a result of a number of factors, including the changing product mix from the acquisitions and divestitures in this period, as well as challenges with some of its major pharmaceutical products, the COX-2 inhibitor drugs.⁶

As part of the analysis of a company's performance, the CFO must consider the events that affect the reported financial results, and how they may affect reported financial results, and explain performance in light of controllable and uncontrollable events. In the case of Pfizer, the utilization of assets must be interpreted considering the affect on revenues of withdrawals of drugs from the market, expiration of patents, and the merging of operations in the case of acquisitions.

Profitability

As you can see in Figure 9.6, the profit margins of Pfizer, Inc., have increased over time, with the dropoff in the 2003 fiscal year attributed in part to changes in product mix from merger-related activities. The net profit margin

⁶ For example, Pfizer merged with Warner-Lambert in 2000 and Pharmacia in 2003.

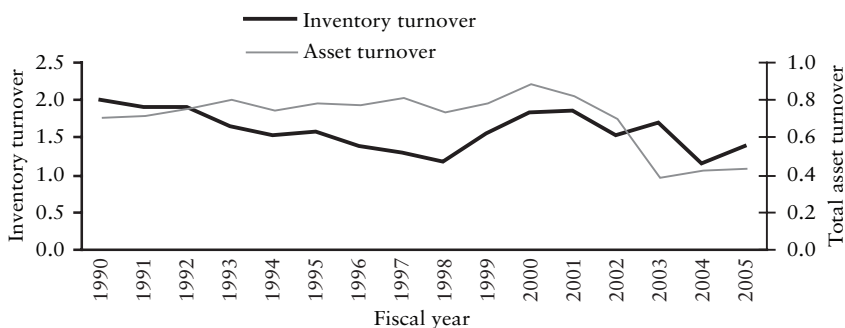
FIGURE 9.5 Turnover Ratios for Pfizer, Inc., 1990–2005

Source of data: The Pfizer, Inc. Company annual reports, various years.

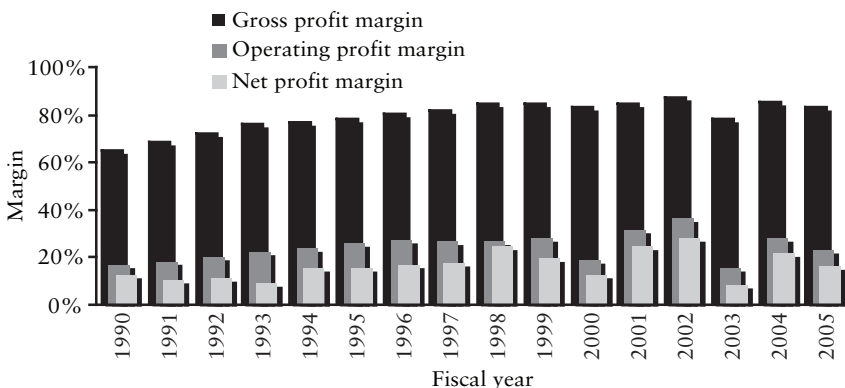
FIGURE 9.6 Profit Margins, Pfizer, Inc., 1990–2005

Source of data: The Pfizer, Inc. Company annual reports, various years.

in 2004 was affected by the impact of the problems with its COX-2 inhibitor drugs, and also by one-time charges related to the Pharmacia merger.

As with the evaluation of activity ratios, the analysis of profitability requires examining the effects of events that are both controllable as well as uncontrollable. Because Pfizer is not a cyclical company, the changes in profitability are not traceable to changes in the economy, but rather are determined by the success of the drugs, the age of its patents, and acquisitions and divestitures.

Financial Leverage

Pfizer, Inc.'s use of debt has varied over the period 1990–2005, as we show in Figure 9.7. However, there appears to be a slight shift to a greater reliance on short-term liabilities during some years and then a noticeable shift to a greater reliance on long-term liabilities, as indicated by the divergence and then convergence of the two debt ratios. Pfizer's short-term debt consists primarily of commercial paper and unsecured notes.

However, when interpreting financial leverage in the case of drug companies such as Pfizer, the issue of whether reported total assets—which are the benchmark used in evaluating the debt burden—truly reflect the assets of the company.

One of the factors that affects the debt ratios is how intangible assets are reported. In the case of a drug company, the company must expense most of the research and development expenditures. Therefore, the reported assets of a drug company understate the intangible assets of a company. Hence, any ratio of debt to total assets overstates the true financial leverage. Additionally, drug companies such as Pfizer book intangibles from acquisitions, and if identifiable, amortize these intangibles. Reported intangibles in the case of Pfizer are 43.86% of its reported total assets. When a company with substantial reported intangible assets writes off a portion of these due to impairment, as Pfizer did for its Bextra drug in 2005, total assets fall. Therefore, looking at the financial leverage ratios without considering the other events of the company may be misleading. In the case of Pfizer, the write-down of the intangibles in 2005, along with the absence of many intangibles from product development from inclusion in total assets, blurs the picture.

FIGURE 9.7 Financial Leverage Ratios, Pfizer, Inc. 1990–2005

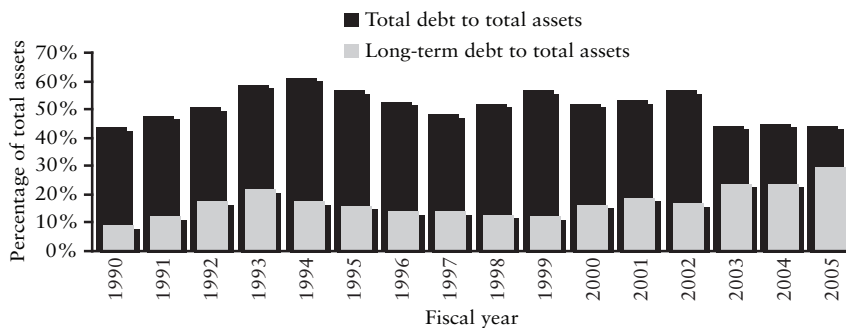

Source of data: The Pfizer, Inc. Company annual reports, various years.

Pfizer's debt at the end of 2005 was rated as high quality; Pfizer's short-term borrowing is rated P-1 and its long-term debt is rated Aaa by Moody's Investor Service.

Return and the DuPont Analysis

We plot the return on equity and return on assets for Pfizer for the years 1990–2005 in Figure 9.8. Both the return on assets and the return on equity are wide-ranging during these years. In general, returns trended upward during the 10-year period 1990–1999, though there was a dropoff in 2000 and continued fluctuations as a result of acquisition and issues related to the drug development.

We provide a breakdown of the return on equity into the three components of net profit margin, asset turnover, and financial leverage, and graph these components in Figure 9.9. The DuPont breakdown suggests that the increased volatility of returns in the post-1999 period is attributed to the more volatile efficiency in managing expenses, as represented by the net profit margin. This provides information that can be used to analyze performance further, focusing attention on expense management. However, any analysis of Pfizer's return must consider the problem associated with the understatement of total assets and shareholders' equity, which affects the interpretation of asset turnover, financial leverage, and returns.

Other Factors

Constant challenges from drug patent expirations and increased competition from generic drug products affect all drug companies. One of the keys to future growth of a drug company is its spending on research and development. Though the results of drug development are not apparent in the car-

FIGURE 9.8 Pfizer, Inc., Returns on Investment, 1990–2005

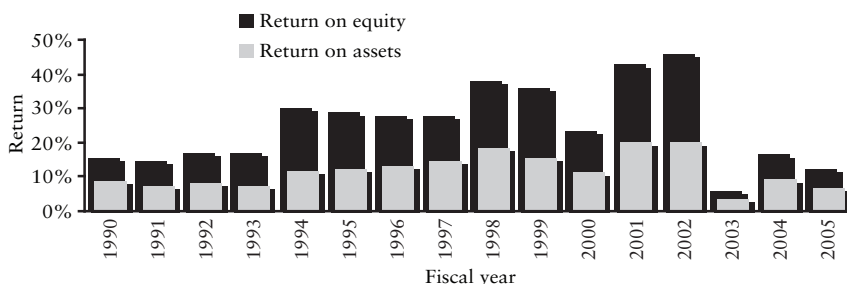

Source of data: The Pfizer, Inc. Company annual reports, various years.

FIGURE 9.9 DuPont Components, Pfizer, Inc., 1990–2005

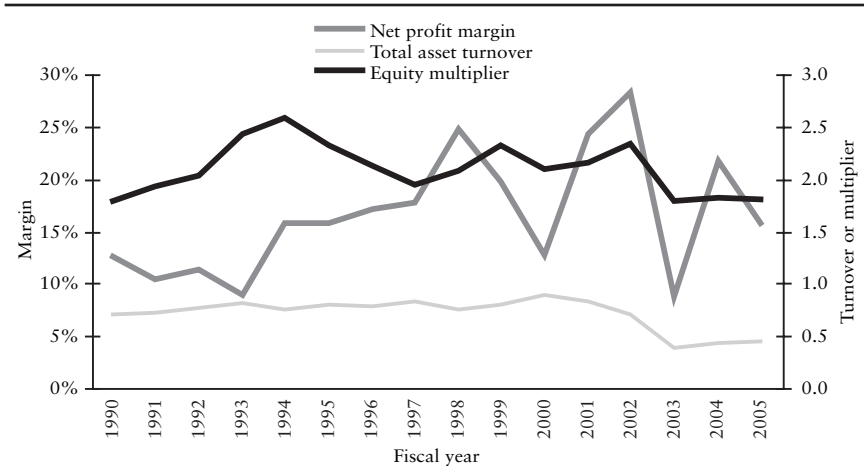

Source of data: The Pfizer, Inc. Company annual reports, various years.

FIGURE 9.10 Pfizer, Inc.’s Research and Development Expenses as a Percentage of Revenues, 1990–2005

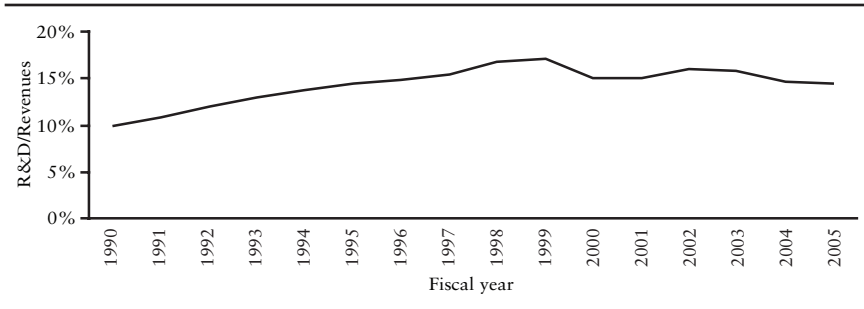

Source of data: The Pfizer, Inc. Company annual reports, various years.

rying value of the company’s assets, another way to examine the investment in research and development is to focus on the relation between revenues and research and development expenditures, as we show in Figure 9.10. Pfizer’s spending on R&D has dropped slightly since 1999. Compared to its competitors, however, Pfizer’s 2005 ratio of R&D spending to revenues of 14.5% is slightly less than the industry average of 17.7% and lower than that of its competitors Eli Lilly and Schering-Plough.⁷

⁷ Source: Standard and Poor’s Industry Survey, “Healthcare: Pharmaceuticals.”

Common-Size Analysis

We can gain another perspective of the company's performance and condition through a common-size analysis of the income statement and balance sheet. We provide the common-size income statement in graphical form in Figure 9.11 and the common-size balance sheet in Figure 9.12.

The trends in the expenses and net income of Pfizer are apparent in the common-size income statement. With the exception of 2003 and 2004, the operating costs have declined over time. The effects of the mergers, in terms of merger-related expenses, can be seen in the change in the nonoperating expenses from 2003 to 2004.

We can also see effects of the mergers in the common-size balance sheets, as we show graphically in Figure 9.12, Panel A. The increased proportionate investment in intangibles is a direct result of acquisitions of Pharmacia and other companies. We can see Pfizer's slight increase in its use of long-term debt in its capital structure, as shown in Panel B of this figure.

Limitations from the Use of Accounting Data

There are a number of issues that arise simply from the fact that much of the financial data we use in analysis is accounting information. The problems associated with using reported accounting data include:

FIGURE 9.11 Common-Size Income Statements, Pfizer, Inc. Company, 1994–2005

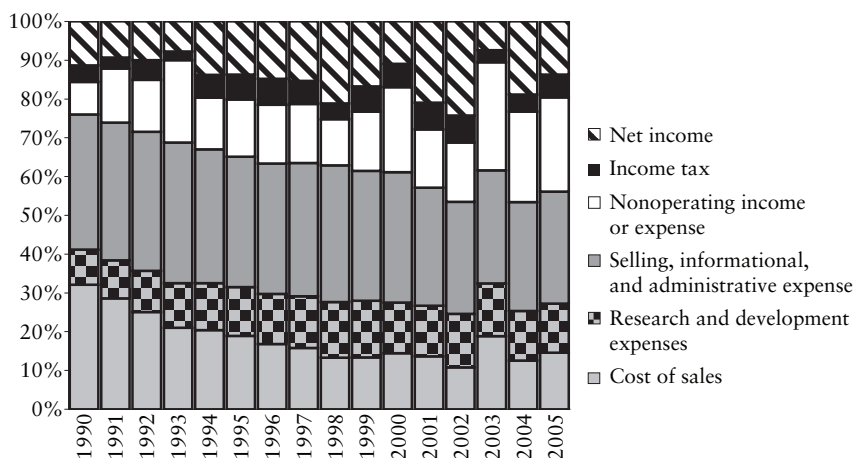

Source of data: The Pfizer, Inc. Company annual reports, various years.

FIGURE 9.12 Common-Size Balance Sheet, Pfizer, Inc. Company, 1990–2005

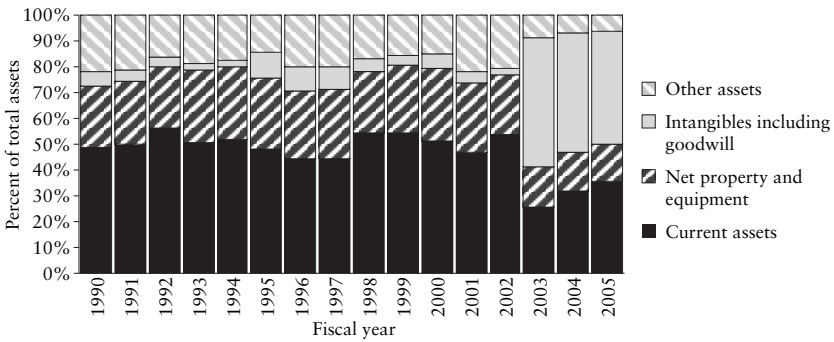

Panel A Assets

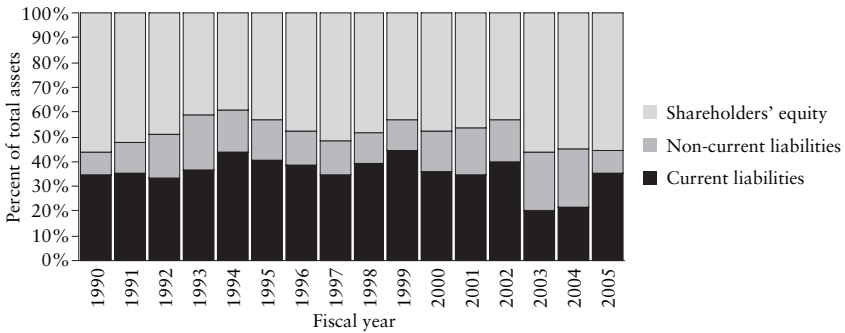

Panel B Liabilities and equity

Source of data: The Pfizer, Inc. Company annual reports, various years.

- The use of historical costs.
- Different methods of accounting.
- Changes in accounting principles.
- Extraordinary and special items.
- Items that are difficult to classify.
- Restatements.

Use of Historical Costs

Accounting data is not adjusted for inflation and represents historical cost instead of current or replacement costs for most assets. It is likely that the reported book value of assets does not reflect the market value or replacement value of a company's assets. In the case of drug companies, as men-

tioned previously, research and development expenditures are, for the most part, expensed—even though research and development expenditures result in intangible assets such as drug patents, the investment and value of these patents do not appear on the balance sheet.

Different Methods of Accounting

Changes in Accounting Principles Accounting principles change over time and changes are especially frequent in recent years as U.S. GAAP converge with International Accounting Standards. For example, in 2005, Pfizer adopted FASB No. 47, “Accounting for Conditional Asset Retirement Obligations,” and FASB Interpretation No. 46R, “Consolidation of Variable Interest Entities.”⁸ Whereas FASB 143 affected net income directly, the adoption of FASB Interpretation No. 46R did not have any material effect.

Extraordinary and Special Items The CFO must determine whether the effects of extraordinary and special items should be included in the analysis. For some companies, extraordinary items have become quite “ordinary,” with some companies reporting extraordinary items each year. In the case of Pfizer, the company has charges for discontinued operations in most years; in some years these have produced income and in other years produced losses.

The Difficulty in Classifying “Fuzzy” Items Some accounting items are difficult to classify, especially when distinguishing between liabilities and equity accounts. In the case of Pfizer, the company has both deferred tax assets and deferred tax liabilities. In 2005, for example, the primary source of deferred tax liability is from the Pharmacia acquisition and the accounting for intangibles; classifying this deferred tax liability requires understanding the tax obligation and the timing of its payment.

Restatements When a company adopts a new accounting principle, the historical fiscal years included in the financial statements—the previous year for the balance sheet and the two previous years for the income statement—are restated according to the newly adopted principle. In addition, financial statements are restated occasionally due to errors or, unfortunately, fraud.

When analyzing a company that has restated its financial statements, questions arise with regard to what data to use; the CFO would want to use

⁸ Adopting SFAS No. 143 resulted in a pre-tax charge of \$40 million in 2005. We discussed FIN 46 in Chapter 3.

the financial data restated according to the current accounting principles and restated to reflect any corrections.

Selecting and Interpreting Ratios

Interpretation of ratios one at a time is difficult since there is no “good” or “bad” value when viewed in isolation. Ratios should be selected that have meaning for that company. For example, inventory turnover for Pfizer is not very meaningful because the investment in inventory is of little consequence for a pharmaceutical company. But inventory turnover is very important for, say, a retailer such as Wal-Mart. And whereas investment in research and development is important for Pfizer, this is much less so for Wal-Mart Stores.

Further, some ratios do not make sense under certain circumstances. For example, if a company has negative earnings, the price-earnings ratio is meaningless. As another example, consider a company that has negative book value of equity (and, yes, this can happen). In this case, any ratio that uses book value of equity, such as the debt-equity ratio, is meaningless.

Another dimension to interpretation is the problems related to interpreting trends. The CFO can use an analysis of trends in ratios and common-size statements to spot shifts that need attention. However, as pointed out in the case of Pfizer, company-specific events, such as mergers and acquisitions, make the identification and interpretation of trends more challenging. Combined with changes in accounting principles, the analysis of trends requires more than a simple plot of ratios over time.

Choosing a Benchmark

To make comparisons, the analyst most likely will want to compare the company with other companies. But identifying the other companies in the same or similar lines of business to use in such a benchmark presents a challenge. A system that has been used for many years for classifying companies by lines of business is the Standard Industrial Classification (SIC) system, which was developed by the Office of Management and Budget. However, starting in 1997, another classification system, North American Industry Classification System (NAICS), replaces SIC codes with a system that better represents the current lines of business. Using the NAICS, we can classify a company and then compare this company with others of that class.

Classifying companies into industry groups is difficult because most companies have more than one line of business. Most large corporations operate in several lines of business. Do we classify a company into an industry by the line of business that represents the:

- Most sales revenue generated?
- Greatest investment in assets?
- Greatest share of the company's profits?

It is not clear which is the most appropriate method. Financial services and analysts may classify a company into different industries. To see this, consider Walt Disney Co. In 2005, it reported four segments: Media Networks, Parks and Resorts, Studio Entertainment, and Consumer Products. Which are the primary segments? It depends on how you look at it. As we show in Figure 9.13, the contribution of a segment may differ significantly depending on whether revenues or operating income define the segment's contribution. A CFO, on the other hand, may view a company's benchmark as defined by its major competitors, regardless of analysts' classifications and government classification systems.

Another issue to consider in using financial data of benchmark companies is that related to the comparability of financial data across firms. Companies may select from alternative accounting procedures (e.g., LIFO vs. FIFO), which makes comparisons among companies difficult. The CFO must often look beyond the basic financial statement information of the constituents of the benchmark to remove distortions that may arise from specific accounting practices. In the case of the drug industry, most companies, including Pfizer, use LIFO for inventory, but not all: Novartis and Bristol Myers Squibb use average costs. Therefore, any comparison of ratios using inventory must consider the possible differences in accounting for costs and the inventory balance sheet account.

FIGURE 9.13 Disney Segment Revenues and Operating Income, 2005

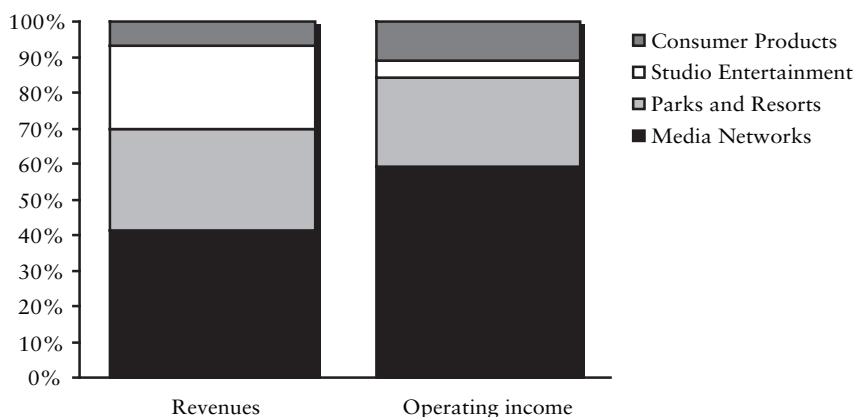

In making comparisons, there is an issue of whether the benchmark should include all other companies in the industry or simply the leading companies in the industry. Consider the case of Dow Chemical, a manufacturer of basic chemicals. The primary competitors to Dow Chemical in this industry are E.I. DuPont de Nemours and Union Carbide, though there are also a number of smaller competitors such as Georgia Gulf and Millennium Chemicals. When comparing Dow Chemical to the industry, questions include:

- Use just the two major competitors as the industry benchmark?
- Consider the smaller competitors at all?
- Compare Dow Chemical with the largest or the most profitable company in the industry?

A further consideration in using an average of competitors is whether to weight the competitors' ratios equally—say, a simple arithmetic average of competitors' ratios—or by some weighting scheme, such using a measure of size as a weight.⁹

The benchmark that a CFO chooses affects the conclusions that are drawn with respect to a company's operating performance relative to the benchmark. Therefore, the CFO must consider carefully the constituents of the benchmark, the comparability of the financial statements of these companies, and the calculation of the benchmark ratios.

Using Ratios in Forecasting

We often examine trends in ratios and other financial data to predict the future, forecasting the future based on historical trends. For example, we may extrapolate a trend in sales or a trend in operating profit. And though this may result in a reasonable forecast for the immediate future, the business environment is very complex and many factors can affect the future performance or conditions of a company.

Consider forecasting Pfizer's net income for 2000 and beyond, based on net income data from 1990–1999. We begin by estimating the trend in the net income over this period, which we graph in Figure 9.14. The net income appears to follow a linear path through these years, as we show in Panel A of this figure. However, when this path is used to forecast net income for

⁹ Equal-weighting competitors involves simply averaging the competitors' ratios. Value-weighting requires a bit more effort: For a value-weighted asset turnover, the numerator is the sum of the revenues of the competitors in the benchmark, divided by the sum of the total assets of the competitors. The latter method gives more weight to the larger constituents of the benchmark.

FIGURE 9.14 Forecasting Pfizer's Net Income

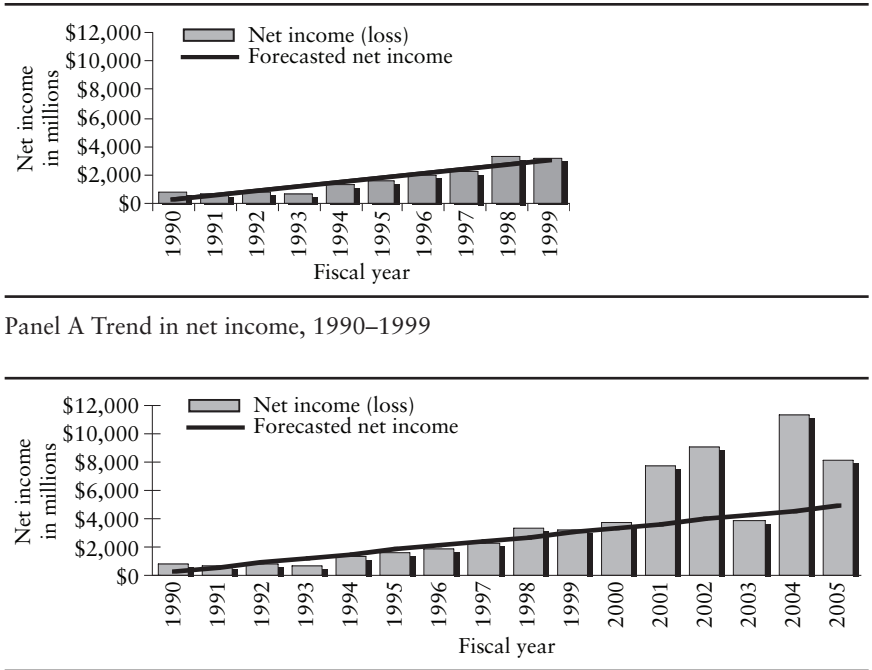

Panel B Forecast error in net income, 2000–2005
 Source of data: Pfizer, Inc. 10-K filings, various years.

the years 2000–2005, the trend does not fit well, as indicated in Panel B of this figure. That’s because the forecast made using 1990–1999 data does not consider, among other things, the company-specific events such as discontinued operations and mergers that took place in the 2000–2005 period; these included significant events for Pfizer such as the acquisition of Warner-Lambert in 2000 and the acquisition of Pharmacia in 2003.

This illustrates why we develop forecasts using information in addition to the basic trend, such as forecasts of company-specific events, as well as economic and market conditions. The CFO must be careful in predicting the future revenues or income of a company based solely on the past. As companies mature, growth slows and these changes must be considered in making any forecasts. How much does growth slow? It depends on many factors, including industry structure (e.g., degree of competition), changing demographics, and government regulation.

BOTTOM LINE

- The basic data for financial analysis is the financial statement data. We use this data to analyze relationships between different elements of a firm's financial statements. Through this analysis, we develop a picture of the operating performance and financial condition of a firm.
- Looking at the calculated financial ratios, in conjunction with industry and economic data, we can make judgments about past and future financial performance and condition.
- We can classify ratios by type—coverage, return, turnover, or component percentage—or by the financial characteristic that we wish to measure—liquidity, profitability, activity, financial leverage, or return.
- Liquidity ratios tell us about a firm's ability to satisfy short-term obligations. These ratios are closely related to a firm's operating cycle, which tells us how long it takes a firm to turn its investment in current assets back into cash.
- Profitability ratios tell us how well a firm manages its assets, typically in terms of the proportion of revenues that are left over after expenses.
- Activity ratios tell us how efficiently a firm manages its assets, that is, how effectively a firm uses its assets to generate sales.
- Financial leverage ratios tell us (1) to what extent a firm uses debt to finance its operations and (2) its ability to satisfy debt and debt-like obligations.
- Return-on-investment ratios tell us how much of each dollar of an investment is generated in a period. The DuPont system breaks down return ratios into their profit margin and activity ratios, allowing us to analyze changes in return on investments.
- Common-size analysis expresses financial statement data relative to some benchmark item—usually total assets for the balance sheet and sales for the income statement. Representing financial data in this way allows an analyst to spot trends in investments and profitability.
- Interpretation of the financial ratios requires the CFO to put the trends and comparisons in perspective with the company's significant events.
- In addition to company-specific events, issues that can cause the analysis of financial ratios to become more challenging include the use of historical accounting values, changes in accounting principles, and accounts that are difficult to classify.
- Comparison of financial ratios across time and with competitors is useful in gauging performance. In comparing ratios over time, the CFO should consider changes in accounting and significant company events. In comparing ratios with a benchmark, the CFO must take care in

the selection of the companies that constitute the benchmark and the method of calculation.

Cash Flow Analysis

AGENDA ITEMS

- Item 1* Discuss the importance of cash flow and its usefulness in financial analysis.
- Item 2* Identify the difficulties associated with measuring cash flow.
- Item 3* Explain the different cash flow measures and how they can be used: discretionary cash flow, free cash flow, and net free cash flow.
- Item 4* Describe how to use cash flow information.

One of the key financial measures that a CFO should understand is the company's cash flow. This is because the cash flow aids the CFO in assessing the ability of the company to satisfy its contractual obligations and maintain current dividends and current capital expenditure policy without relying on external financing. Moreover, a CFO must understand why this measure is important for external parties, specifically stock analysts covering the company. The reason is that the basic valuation principle followed by stock analysts is that the value of a company today is the present value of its expected future cash flows. In this chapter, we discuss cash flow analysis.

DIFFICULTIES WITH MEASURING CASH FLOW

The primary difficulty with measuring a cash flow is that it is a flow: Cash flows into the company (cash inflows) and cash flows out of the company (cash outflows). At any point in time there is a stock of cash on hand, but the stock of cash on hand varies among companies because of the size of the company, the cash demands of the business, and a company's management of working capital. So what is cash flow? Is it the total amount of cash flowing into the company during a period? Is it the total amount of cash flowing out of the company during a period? Is it the net of the cash inflows and outflows for a period? Well, there is no specific definition of cash flow—and that's

probably why there is so much confusion regarding the measurement of cash flow. Ideally, a measure of the company's operating performance that is comparable among companies is needed—something other than net income.

A simple, yet crude method of calculating cash flow requires simply adding noncash expenses (e.g., depreciation and amortization) to the reported net income amount to arrive at cash flow. For example, the estimated cash flow for Procter & Gamble (P&G) for 2002, is:

$$\begin{aligned}\text{Estimated cash flow} &= \text{Net income} &+& \text{Depreciation and amortization} \\ \text{Estimated cash flow} &= \$4,352 \text{ million} &+& 1,693 \text{ million} \\ &= \$6,045 \text{ million}\end{aligned}$$

This amount is not really a cash flow, but simply earnings before depreciation and amortization. Is this a cash flow that stock analysts should use in valuing a company? Though not a cash flow, this estimated cash flow does allow a quick comparison of income across firms that may use different depreciation methods and depreciable lives.¹

The problem with this measure is that it ignores the many other sources and uses of cash during the period. Consider the sale of goods for credit. This transaction generates sales for the period. Sales and the accompanying cost of goods sold are reflected in the period's net income and the estimated cash flow amount. However, until the account receivable is collected, there is no cash from this transaction. If collection does not occur until the next period, there is a misalignment of the income and cash flow arising from this transaction. Therefore, the simple estimated cash flow ignores some cash flows that, for many companies, are significant.

Another estimate of cash flow that is simple to calculate is *EBITDA*—earnings before interest, taxes, depreciation, and amortization. However, this measure suffers from the same accrual-accounting bias as the previous measure, which may result in the omission of significant cash flows. Additionally, *EBITDA* does not consider interest and taxes, which may also be substantial cash outflows for some companies.²

These two rough estimates of cash flows are used in practice not only for their simplicity, but because they experienced widespread use prior to the disclosure of more detailed information in the statement of cash flows.

¹ An example of the use of this estimate of cash flow, *The Value Line Investment Survey*, published by Value Line, Inc., reports a cash flow per share amount, calculated as reported earnings plus depreciation, minus any preferred dividends, stated per share of common stock (*Guide to Using the Value Line Investment Survey* (New York: Value Line, Inc.), p. 19, available at <http://www.valueline.com>).

² For a more detailed discussion of the *EBITDA* measure, see Kent Eastman, "EBITDA: An Overrated Tool for Cash Flow Analysis," *Commercial Lending Review* (Spring 1997) p. 64.

Currently, the measures of cash flow are wide-ranging, including the simplistic cash flow measures, measures developed from the statement of cash flows, and measures that seek to capture the theoretical concept of “free cash flow.”

CASH FLOWS AND THE STATEMENT OF CASH FLOWS

Prior to the adoption of the statement of cash flows, the information regarding cash flows was quite limited. The first statement that addressed the issue of cash flows was the statement of financial position, which was required starting in 1971.³ This statement was quite limited, requiring an analysis of the sources and uses of funds in a variety of formats. In its earlier years of adoption, most companies provided this information using what is referred to as the *working capital concept*—a presentation of working capital provided and applied during the period. Over time, many companies began presenting this information using the *cash concept*, which is a most detailed presentation of the cash flows provided by operations, investing, and financing activities.⁴

Consistent with the cash concept format of the funds flow statement, the statement of cash flows is now a required financial statement. The requirement that companies provide a statement of cash flows applies to fiscal years after 1987.⁵ This statement requires the company to classify cash flows into three categories, based on the activity: operating, investing, and financing. Cash flows are summarized by activity and within activity by type (e.g., asset dispositions are reported separately from asset acquisitions).

The reporting company may report the cash flows from operating activities on the statement of cash flows using either the *direct method*—reporting all cash inflows and outflows—or the *indirect method*—starting with net income and making adjustments for depreciation and other noncash expenses and for changes in working capital accounts. Though the direct method is recommended, it is also the most burdensome for the reporting company to prepare. Most companies report cash flows from operations using the indirect

³ *APB Opinion No. 19*, “Reporting Changes in Financial Position,” AICPA (New York: 1971). Prior to this APB, *APB Opinion No. 3*, “The Statement of Source and Application of Funds,” AICPA (New York: 1963) encouraged, but did not require, companies to report information regarding the changes in cash over a period (referred to as the *flow of funds*).

⁴ This change in format generally followed the recommendations of the Financial Executives Institute and the Financial Accounting Standards Board recommendations, *FASB Discussion Memorandum*, “Conceptual Framework for Accounting and Reporting” (Stamford: Financial Accounting Standards Board, 1974).

⁵ *Statement of Financial Accounting Standards No. 95*, “Statement of Cash Flows” (Stamford: Financial Accounting Standards Board, 1987).

method. The indirect method has the advantage of providing the financial statement user with a reconciliation of the company's net income with the change in cash. The indirect method produces a cash flow from operations that is similar to the estimated cash flow measure discussed previously, yet it encompasses the changes in working capital accounts that the simple measure does not. For example, Procter & Gamble's cash flow from operating activities (taken from their 2002 statement of cash flows) is \$7,742 million, which is over \$1 billion more than the cash flow that we estimated earlier.⁶

The classification of cash flows into the three types of activities provides useful information that can be used by both the CFO and a stock analyst to see, for example, whether the company is generating sufficient cash flows from operations to sustain its current rate of growth. However, the classification of particular items is not necessarily as useful as it could be. Consider some of the classifications:

- Cash flows related to interest expense are classified in operations, though they are clearly financing cash flows.
- Income taxes are classified as operating cash flows, though taxes are affected by financing (e.g., deduction for interest expense paid on debt) and investment activities (e.g., the reduction of taxes from tax credits on investment activities).
- Interest income and dividends received are classified as operating cash flows, though these flows are a result of investment activities.

Whether these items have a significant effect on the analysis depends on the particular company's situation. Procter & Gamble, for example, has very little interest and dividend income, and its interest expense of \$603 million is not large relative to its earnings before interest and taxes (\$6,986 million). Adjusting P&G's cash flows for the interest expense only (and related taxes) changes the complexion of its cash flows slightly to reflect greater cash flow generation from operations and less cash flow reliance on financing activities:⁷

| (In Millions) | As Reported | As Adjusted |
|---|-------------|-------------|
| Cash flow from operations | \$7,741 | \$8,134 |
| Cash flow for investing activities | (6,835) | (6,835) |
| Cash flow from (for) financing activities | 197 | (195) |

Source: Procter & Gamble 2002 Annual Report

⁶ Procter & Gamble's fiscal year ends June 30, 2002.

⁷ The adjustment is for \$603 million of interest and other financing costs, less its tax shield (the amount that the tax bill is reduced by the interest deduction) of \$211 (estimated from the average tax rate of 35% of \$603): adjustment = \$603 (1 - 0.35) = \$392.

For other companies, however, this adjustment may provide a less flattering view of cash flows. Consider Amazon.com's fiscal year results. Interest expense to financing, along with their respective estimated tax effects, results in more reliance on cash flow from financing:⁸

| (In Millions) | As Reported | As Adjusted |
|-------------------------------------|-------------|-------------|
| Cash flow from operations | \$(120) | \$(30) |
| Cash flow for investing activities | (253) | (253) |
| Cash flow from financing activities | (107) | 17 |

Source: Amazon.com 2001 10-K

Looking at the relation among the three cash flows in the statement provides a sense of the activities of the company. A young, fast-growing company may have negative cash flows from operations, yet positive cash flows from financing activities (i.e., operations may be financed in large part with external financing). As a company grows, it may rely to a lesser extent on external financing. The typical, mature company generates cash from operations and reinvests part or all of it back into the company. Therefore, cash flow related to operations is positive (i.e., a source of cash) and cash flow related to investing activities is negative (i.e., a use of cash). As a company matures, it may seek less financing externally and may even use cash to reduce its reliance on external financing (e.g., repay debts). We can classify companies on the basis of the pattern of their sources of cash flows, as shown in Table 10.1. Though additional information is required to assess a company's financial performance and condition, examination of the sources of cash flows, especially over time, gives us a general idea of the company's operations. P&G's cash flow pattern is consistent with that of a mature

TABLE 10.1 Patterns of Sources of Cash Flows

| Cash Flow | Financing Growth | | Mature | Temporary Financial Downturn | Financial Distress | Downsizing |
|----------------------|---------------------------|-----------------------------|--------|------------------------------|--------------------|------------|
| | Externally and Internally | Financing Growth Internally | | | | |
| Operations | + | + | + | - | - | + |
| Investing activities | - | - | - | + | - | + |
| Financing activities | + | - | + or - | + | - | - |

⁸ The adjustment is based on interest expense of \$139 million, and a tax rate of 35%.

company, whereas Amazon.com's cash flows are consistent with those of a fast-growing company that is reliant on outside funds for growth.

Martin Fridson suggests reformatting the statement of cash flows as shown in Table 10.2.⁹ From the basic cash flow, the nondiscretionary cash needs are subtracted resulting in a cash flow referred to as *discretionary cash flow*. By restructuring the statement of cash flows in this way, it can be seen how much flexibility the company has when it must make business decisions that may adversely impact the long-run financial health of the enterprise.

For example, consider a company with a basic cash flow of \$800 million and operating cash flow of \$500 million. Suppose that this company pays dividends of \$130 million and that its capital expenditure is \$300 million. Then the discretionary cash flow for this company is \$200 million found by subtracting the \$300 million capital expenditure from the operating cash flow of \$500 million. This means that even after maintaining a dividend payment of

TABLE 10.2 Suggested Reformatting of Cash Flow Statement to Analyze a Company's Flexibility

| | |
|-------|--|
| | Basic cash flow |
| Less: | Increase in adjusted working capital |
| | Operating cash flow |
| Less: | Capital expenditures |
| | Discretionary cash flow |
| Less: | Dividends |
| Less: | Asset sales and other investing activities |
| | Cash flow before financing |
| Less: | Net (increase) in long-term debt |
| Less: | Net (increase) in notes payable |
| Less: | Net purchase of company's common stock |
| Less: | Miscellaneous |
| | Cash flow |

Notes:

1. The basic cash flow includes net earnings, depreciation, and deferred income taxes, less items in net income not providing cash.
2. The increase in adjusted working capital excludes cash and payables.

Source: This format was suggested by Martin S. Fridson, *Financial Statement Analysis: A Practitioner's Guide* (New York: John Wiley & Sons, 1995).

⁹ Martin S. Fridson, *Financial Statement Analysis: A Practitioner's Guide* (New York: John Wiley & Sons, 1995).

\$130 million, its cash flow is positive. Notice that asset sales and other investing activity are not needed to generate cash to meet the dividend payments because in Table 10.2 these items are subtracted after accounting for the dividend payments. In fact, if this company planned to increase its capital expenditures, the format in Table 10.2 can be used to assess how much that expansion can be before affecting dividends and/or increasing financing needs.

Though we can classify a company based on the sources and uses of cash flows, more data is needed to put this information in perspective. What is the trend in the sources and uses of cash flows? What market, industry, or company-specific events affect the company's cash flows? How does the company being analyzed compare with other companies in the same industry in terms of the sources and uses of funds?

Let's take a closer look at the incremental information provided by cash flows. Consider Wal-Mart Stores, Inc., which had growing sales and net income from 1990 to 2005, as summarized in Figure 10.1. We see that net income grew each year, with the exception of 1995, and that sales grew each year.

We get additional information by looking at the cash flows and their sources, as graphed in Figure 10.2. We see that the growth in Wal-Mart was supported both by internally generated funds and, to a lesser extent, through external financing. Wal-Mart's pattern of cash flows suggests that Wal-Mart is a mature company that has become less reliant on external financing, funding most of its growth in recent years (with the exception of 1999) with internally generated funds.

FIGURE 10.1 Wal-Mart Stores, Inc., Revenues, Operating Profit, and Net Income, 1990–2005

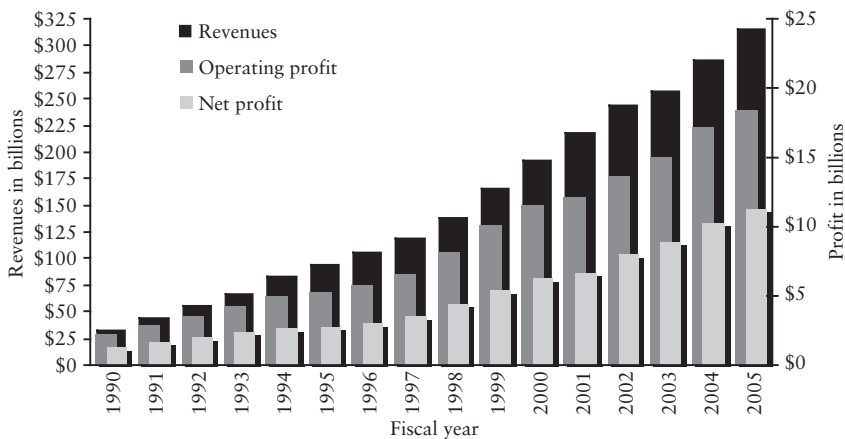

Source: Wal-Mart Stores, Inc., Annual Report, various years.

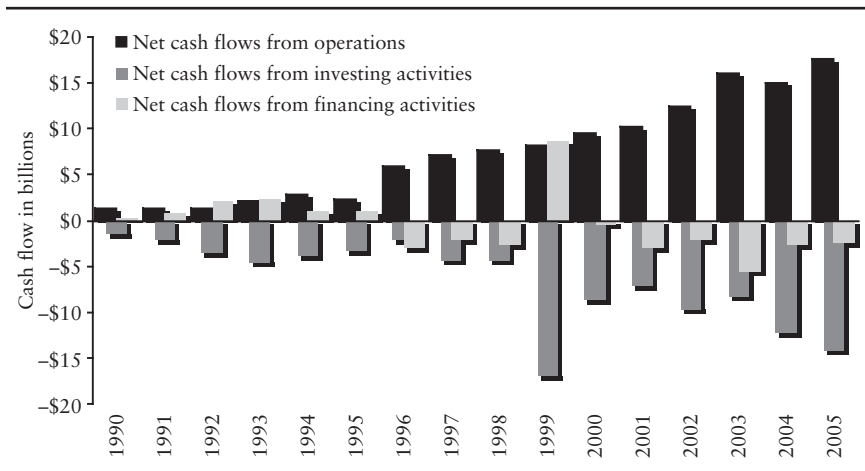
FIGURE 10.2 Wal-Mart Stores, Inc., Cash Flows, 1990–2005

Source: Wal-Mart Stores, Inc., Annual Report, various years.

FREE CASH FLOW

Cash flows without any adjustment may be misleading because they do not reflect the cash outflows that are necessary for the future existence of a firm. An alternative measure, free cash flow, was developed by Michael Jensen in his theoretical analysis of agency costs and corporate takeovers.¹⁰ In theory, *free cash flow* is the cash flow left over after the company funds all positive net present value projects. *Positive net present value projects*, as will be explained in Chapter 15, are those capital investment projects for which the present value of expected future cash flows exceeds the present value of project outlays, all discounted at the cost of capital.¹¹ In other words, free cash flow is the cash flow of the firm, less capital expenditures necessary to stay in business (i.e., replacing facilities as necessary) and grow at the expected rate (which requires increases in working capital).

The theory of free cash flow was developed by Jensen to explain behaviors of companies that could not be explained by existing economic theories. Jensen observed that companies that generate free cash flow should disgorge that cash rather than invest the funds in less profitable investments.

¹⁰ Michael Jensen, “Agency Costs of Free Cash Flow, Corporate Finance, and Takeovers,” *American Economic Review* (May 1986), pp. 323–329.

¹¹ The cost of capital is the cost to the company of funds from creditors and shareholders. The cost of capital is basically a hurdle: If a project returns more than its cost of capital, it is a profitable project.

There are many ways in which companies can disgorge this excess cash flow, including the payment of cash dividends, the repurchase of stock, and debt issuance in exchange for stock. The debt-for-stock exchange, for example, increases the company's leverage and future debt obligations, obligating the future use of excess cash flow. If a company does not disgorge this free cash flow, there is the possibility that another company—a company whose cash flows are less than its profitable investment opportunities or a company that is willing to purchase and lever-up the company—will attempt to acquire the free-cash-flow-laden company.

As a case in point, Jensen observed that the oil industry illustrates the case of wasting resources: The free cash flows generated in the 1980s were spent on low-return exploration and development and on poor diversification attempts through acquisitions. He argues that these companies would have been better off paying these excess cash flows to shareholders through share repurchases or exchanges with debt.

By itself, the fact that a company generates free cash flow is neither good nor bad. What the company *does* with this free cash flow is what is important. And this is where it is important to measure the free cash flow as that cash flow in excess of profitable investment opportunities. Consider the simple numerical exercise with the Winner Company and the Loser Company:

| | Winner Company | Loser Company |
|---|-------------------|------------------|
| Cash flow before capital expenditures | \$1,000 | \$1,000 |
| Capital expenditures, positive net present value projects | (750) | (250) |
| Capital expenditures, negative net present value projects | <u>0</u> | <u>(500)</u> |
| Cash flow | <u>\$250</u> | <u>\$250</u> |
| Free cash flow | \$250 | \$750 |

These two companies have identical cash flows and the same total capital expenditures. However, the Winner Company spends only on profitable projects (in terms of positive net present value projects), whereas the Loser Company spends on both profitable projects and wasteful projects. The Winner Company has a lower free cash flow than the Loser Company, indicating that they are using the generated cash flows in a more profitable manner. The lesson is that the existence of a high level of free cash flow is not necessarily good—it may simply suggest that the company is either a very good takeover target or the company has the potential for investing in unprofitable investments.

Positive free cash flow may be good or bad news; likewise, negative free cash flow may be good or bad news:

| | Good News | Bad News |
|-------------------------|---|--|
| Positive free cash flow | The company is generating substantial operating cash flows, beyond those necessary for profitable projects. | The company is generating more cash flows than it needs for profitable projects and may waste these cash flows on unprofitable projects. |
| Negative free cash flow | The company has more profitable projects than it has operating cash flows and must rely on external financing to fund these projects. | The company is unable to generate sufficient operating cash flows to satisfy its investment needs for future growth. |

Therefore, once the free cash flow is calculated, other information (e.g., trends in profitability) must be considered to evaluate the operating performance and financial condition of the firm.

CALCULATING FREE CASH FLOW

There is some confusion when this theoretical concept is applied to actual companies. The primary difficulty is that the amount of capital expenditures necessary to maintain the business at its current rate of growth is generally not known; companies do not report this item and may not even be able to determine how much of a period's capital expenditures are attributed to maintenance and how much are attributed to expansion.

Consider Procter & Gamble's property, plant, and equipment for 2002, which comprise some, but not all, of P&G's capital investment:¹²

| | |
|--|-----------------|
| Additions to property, plant, and equipment | \$1,679 million |
| Dispositions of property, plant, and equipment | <u>(227)</u> |
| Net change before depreciation | \$1,452 million |

How much of the \$1,679 million is for maintaining P&G's current rate of growth and how much is for expansion? Though there is a positive net change of \$1,452 million, does it mean that P&G is expanding? Not necessarily: The additions are at current costs, whereas the dispositions are at historical costs. The additions of \$1,679 are less than P&G's depreciation and amortization expense for 2001 of \$1,693 million, yet it is not disclosed in

¹² In addition to the traditional capital expenditures (i.e., changes in property, plant, and equipment), P&G also has cash flows related to investment securities and acquisitions. These investments are long-term and are hence part of P&G's investment activities cash outflow of \$6,835 million.

the financial reports how much of this latter amount reflects amortization.¹³ The amount of necessary capital expenditures is therefore elusive.

Some estimate free cash flow by assuming that all capital expenditures are necessary for the maintenance of the current growth of the company. Though there is little justification in using all expenditures, this is a practical solution to an impractical calculation. This assumption allows us to estimate free cash flows using published financial statements.

Another issue in the calculation is defining what is truly “free” cash flow. Generally we think of “free” cash flow as that being left over after all necessary financing expenditures are paid; this means that free cash flow is after interest on debt is paid. Some calculate free cash flow before such financing expenditures, others calculate free cash flow after interest, and still others calculate free cash flow after both interest and dividends (assuming that dividends are a commitment, though not a *legal* commitment).

There is no one correct method of calculating free cash flow and different analysts may arrive at different estimates of free cash flow for a company. The problem is that it is impossible to measure free cash flow as dictated by the theory, so many methods have arisen to calculate this cash flow. A simple method is to start with the cash flow from operations and then deduct capital expenditures. For P&G in 2002,

| | |
|-----------------------------|----------------|
| Cash flow from operations | \$7,742 |
| Deduct capital expenditures | <u>(1,692)</u> |
| Free cash flow | \$6,050 |

Though this approach is rather simple, the cash flow from the operations amount includes a deduction for interest and other financing expenses. Making an adjustment for the after-tax interest and financing expenses, as we did earlier for Procter & Gamble,

| | |
|---|----------------|
| Cash flow from operations (as reported) | \$7,742 |
| Adjustment | <u>392</u> |
| Cash flow from operations (as adjusted) | \$8,134 |
| Deduct capital expenditures | <u>(1,692)</u> |
| Free cash flow | \$6,442 |

We can relate free cash flow directly to a company’s income. Starting with net income, we can estimate free cash flow using four steps:

Step 1: Determine earnings before interest and taxes (EBIT).

¹³ P&G’s depreciation and amortization are reported together as \$1,693 million on the statement of cash flows.

- Step 2: Calculate earnings before interest but after taxes.
- Step 3: Adjust for noncash expenses (e.g., depreciation).
- Step 4: Adjust for capital expenditures and changes in working capital.

Using these four steps, we can calculate the free cash flow for Procter & Gamble for 2002, as shown in Table 10.3.

NET FREE CASH FLOW

There are many variations in the calculation of cash flows that are used in analyses of companies' financial condition and operating performance. As an example of these variations, consider the alternative to free cash flow developed by Fitch, a company that rates corporate debt instruments. This cash flow measure, referred to as *net free cash flow (NFCF)*, is free cash flow less interest and other financing costs and taxes. In this approach, free cash flow is defined as earnings before depreciation, interest, and taxes, less capital expenditures. Capital expenditures encompass all capital spending, whether for maintenance or expansion, and no changes in working capital are considered.

The basic difference between NFCF and free cash flow is that the financing expenses—interest and, in some cases, dividends—are deducted. If preferred dividends are perceived as nondiscretionary—that is, investors come to expect the dividends—dividends may be included with the interest commitment to arrive at net free cash flow. Otherwise, dividends are deducted from net free cash flow to produce cash flow. Another difference is that NFCF does not consider changes in working capital in the analysis.

Further, cash taxes are deducted to arrive at net free cash flow. Cash taxes are the income tax expense restated to reflect the actual cash flow related to this obligation, rather than the accrued expense for the period. Cash taxes are the income tax expense (from the income statement) adjusted for the change in deferred income taxes (from the balance sheets).¹⁴ For Procter & Gamble in 2002,

| | |
|--|---------|
| Income tax expense | \$2,031 |
| Deduct increase in deferred income tax | (389) |
| Cash taxes | \$1,642 |

¹⁴ Cash taxes require taking the tax expense and either increasing this to reflect any decrease in deferred taxes (that is, the payment this period of tax expense recorded in a prior period) or decreasing this amount to reflect any increase in deferred taxes (that is, the deferment of some of the tax expense).

TABLE 10.3 Calculation of Procter & Gamble's Free Cash Flow for 2002, in Millions^a

| | |
|--|----------------|
| <i>Step 1:</i> | |
| Net income | \$4,352 |
| Add taxes | 2,031 |
| Add interest | <u>603</u> |
| Earnings before interest and taxes | \$6,986 |
| <i>Step 2:</i> | |
| Earnings before interest and taxes | \$6,986 |
| Deduct taxes (@35%) | <u>(2,445)</u> |
| Earnings before interest | \$4,541 |
| <i>Step 3:</i> | |
| Earnings before interest | \$4,541 |
| Add depreciation and amortization | 1,693 |
| Add increase in deferred taxes | <u>389</u> |
| Earnings before noncash expenses | \$6,623 |
| <i>Step 4:</i> | |
| Earnings before noncash expenses | \$6,623 |
| Deduct capital expenditures | (1,679) |
| Add decrease in receivables | \$96 |
| Add decrease in inventories | 159 |
| Add cash flows from changes in accounts payable, accrued expenses, and other liabilities | 684 |
| Deduct cash flow from changes in other operating assets and liabilities | <u>(98)</u> |
| Cash flow from change in working capital accounts | <u>841</u> |
| Free cash flow | <u>\$5,785</u> |

^a Procter & Gamble's fiscal year ended June 30, 2002. Charges in operating accounts are taken from Procter & Gamble's Statement of Cash Flows.

In the case of Procter & Gamble for 2002,

| | |
|---|----------------|
| EBIT | \$6,986 |
| Add depreciation and amortization | <u>1,693</u> |
| Earnings before interest, taxes, depreciation, and amortization | \$8,679 |
| Deduct capital expenditures | <u>(1,679)</u> |
| Free cash flow | \$7,000 |
| Deduct interest | (603) |
| Deduct cash taxes | <u>(1,642)</u> |
| Net free cash flow | \$4,755 |
| Deduct cash common dividends | <u>(2,095)</u> |
| Net cash flow | \$2,660 |

The free cash flow amount per this calculation differs from the \$5,785 that we calculated earlier for two reasons: Changes in working capital and the deduction of taxes on operating earnings were not considered.

Net cash flow gives an idea of the unconstrained cash flow of the company. This cash flow measure may be useful from a creditor's perspective in terms of evaluating the company's ability to fund additional debt. From a shareholder's perspective, net cash flow (i.e., net free cash flow net of dividends) may be an appropriate measure because this represents the cash flow that is reinvested in the company.

USEFULNESS OF CASH FLOWS IN FINANCIAL ANALYSIS

The usefulness of cash flows for financial analysis depends on whether cash flows provide unique information or provide information in a manner that is more accessible or convenient for the user such as a CFO or stock analyst. The cash flow information provided in the statement of cash flows, for example, is not necessarily unique because most, if not all, of the information is available through analysis of the balance sheet and income statement. What the statement does provide is a classification scheme that presents information in a manner that is easier to use and, perhaps, more illustrative of the company's financial position.

An analysis of cash flows and the sources of cash flows can reveal the following information:

- *The sources of financing the company's capital spending.* Does the company generate internally (i.e., from operations) a portion or all of the

funds needed for its investment activities? If a company cannot generate cash flow from operations, this may indicate problems up ahead. Reliance on external financing (e.g., equity or debt issuance) may indicate a company's inability to sustain itself over time.

- *The company's dependence on borrowing.* Does the company rely heavily on borrowing that may result in difficulty in satisfying future debt service?
- *The quality of earnings.* Large and growing differences between income and cash flows suggest a low quality of earnings.

Consider financial results of OEA, Inc., a manufacturer of propellants and pyrotechnic devices (such as those used in air bags), as presented in Figure 10.3.¹⁵ As we can see in this figure, both operating income and net income are growing over time, with a slight interruption of this growth in 1992. We can take off the “rose-colored glasses” of income and look at cash flows to get a much different picture of the company, as shown in Figure 10.4. As we can see in this figure, the growth in investment expenditures has continued over time, yet the company is less able to generate funds from operations; in fact, in 1997 OEA relied entirely on external financing. This

FIGURE 10.3 OEA, Inc., Operating and Net Income 1988–1997

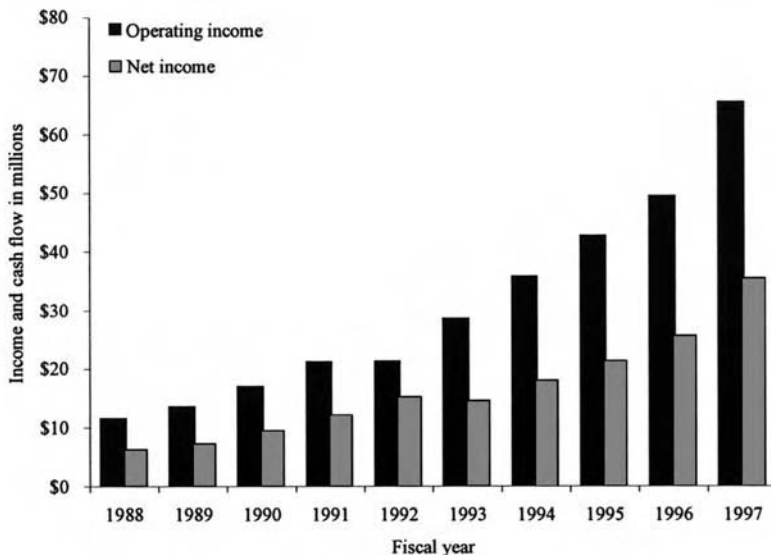

Source: OEA, Inc., Annual Report, various years.

¹⁵ OEA, Inc., was acquired in 2000 by Autoliv, Inc.

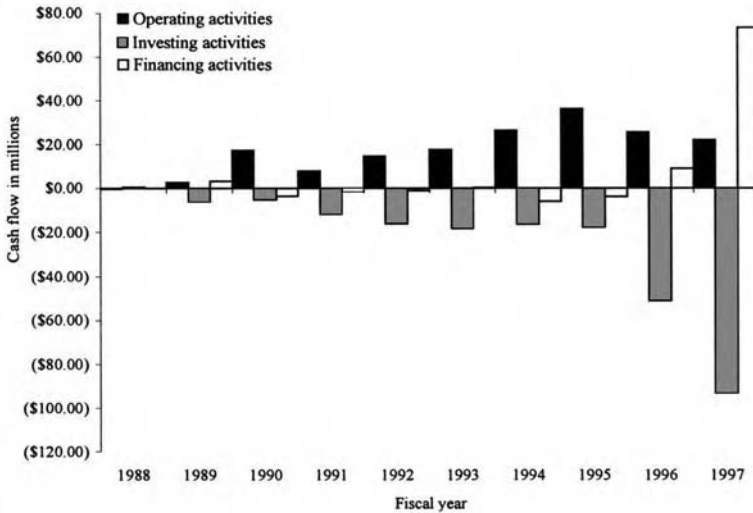
FIGURE 10.4 OEA, Inc., Sources of Cash Flows, 1988–1997

Source: OEA, Inc., Annual Report, various years.

difficulty is associated with the recent concerns over air bags, the reengineering of air bags, and OEA's heavy reliance on the airbags for its revenues (80%). OEA's recent financial challenges are not reflected in the income figures, but are detected with an analysis of the sources of cash flows.

Ratio Analysis

One use of cash flow information is in ratio analysis, much like we did in Chapter 9 primarily with the balance sheet and income statement information. In that chapter we used a cash flow–based ratio, the cash flow interest coverage ratio, as a measure of financial risk. There are a number of other cash flow–based ratios that a CFO and a stock analyst may find useful in evaluating the operating performance and financial condition of a company.

A useful ratio to help further assess a company's cash flow is the *cash flow to capital expenditures ratio*, or *capital expenditures coverage ratio*:¹⁶

$$\text{Cash flow to capital expenditures} = \frac{\text{Cash flow}}{\text{Capital expenditures}}$$

¹⁶ The cash flow measure in the numerator should be one that has not already removed capital expenditures; for example, including free cash flow in the numerator would be inappropriate.

This ratio provides information about the financial flexibility of the company and is particularly useful for capital-intensive firms and utilities.¹⁷ The larger the ratio, the greater the financial flexibility. However, one must carefully examine the reasons why this ratio may be changing over time and why it might be out of line with comparable firms in the industry. For example, a declining ratio can be interpreted in two ways. First, the firm may eventually have difficulty adding to capacity via capital expenditures without the need to borrow funds. The second interpretation is that the firm may have gone through a period of major capital expansion and therefore it will take time for revenues to be generated that will increase the cash flow from operations to bring the ratio to some normal long-run level.

Another useful cash flow ratio is the *cash flow to debt ratio*:

$$\text{Cash flow to debt} = \frac{\text{Cash flow}}{\text{Debt}}$$

where debt can be represented as total debt, long-term debt, or a debt measure that captures a specific range of maturity (e.g., debt maturing in five years). This ratio gives a measure of a company's ability to meet maturing debt obligations. A more specific formulation of this ratio is Fitch's CFAR ratio, which compares a company's three-year average net free cash flow to its maturing debt over the next five years.¹⁸ By comparing the company's average net free cash flow to the expected obligations in the near term (i.e., five years), this ratio provides information on the company's credit quality.

Using Cash Flow Information

The analysis of cash flows provides information that can be used along with other financial data to help assess the financial condition of a company. Consider the cash flow to debt ratio calculated using three different measures of cash flow—EBITDA, free cash flow, and cash flow from operations (from the statement of cash flows)—each compared with long-term debt, as shown in Figure 10.5 for Weirton Steel.

This example illustrates the need to understand the differences among the cash flow measures. The effect of capital expenditures in the 1988–1991 period can be seen by the difference between the free cash flow measure and the other two measures of cash flow; both EBITDA and cash flow from operations ignore capital expenditures, which were substantial outflows for this company in the earlier period.

¹⁷ Fridson, *Financial Statement Analysis*, p. 173.

¹⁸ Daniel J. McConville, "Cash Flow Ratios Gains Respect as Useful Tool for Credit Rating," *Corporate Cashflow* (January 1996), p. 18.

FIGURE 10.5 Cash Flow to Debt Using Alternative Estimates of Cash Flow for Weirton Steel, 1988–1996

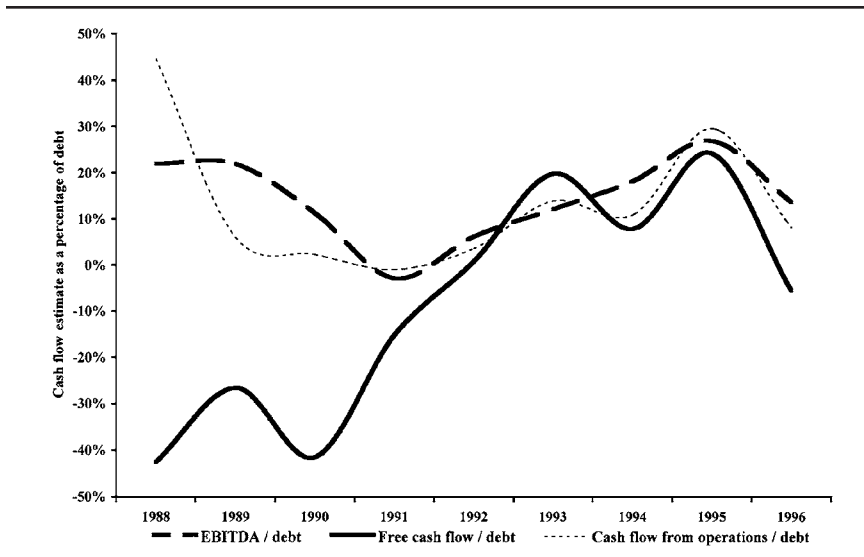

Source: Weirton Steel's 10-K reports, various years.

Cash flow information may help a stock or bond analyst identify companies that may encounter financial difficulties. Consider the study by Largay and Stickney that analyzed the financial statements of W. T. Grant during the 1966–1974 period preceding its bankruptcy in 1975 and ultimate liquidation.¹⁹ They noted that financial indicators such as profitability ratios, turnover ratios, and liquidity ratios showed some down trends, but provided no definite clues to the company's impending bankruptcy. A study of cash flows from operations, however, revealed that company operations were causing an increasing drain on cash, rather than providing cash.²⁰ This necessitated an increased use of external financing, the required interest payments on which exacerbated the cash flow drain. Cash flow analysis clearly was a valuable tool in this case since W. T. Grant had been running a negative cash flow from operations for years. Yet none of the traditional ratios discussed above take into account the cash flow from operations. Use of the cash flow to capital expenditures ratio and the cash flow to debt ratio would have highlighted the company's difficulties.

¹⁹ J. A. Largay III and C. P. Stickney, "Cash Flows, Ratio Analysis and the W. T. Grant Company Bankruptcy," *Financial Analysts Journal* (July/August 1980), pp. 51–54.

²⁰ For the period investigated, a statement of changes of financial position (on a working capital basis) was required to be reported prior to 1988.

More recently, Dugan and Samson examined the use of operating cash flow as an early warning signal of a company's potential financial problems.²¹ The subject of the study was Allied Products Corporation because for a decade this company exhibited a significant divergence between cash flow from operations and net income. For parts of the period, net income was positive while cash flow from operations was a large negative value. In contrast to W. T. Grant, which went into bankruptcy, the auditor's report in the 1991 Annual Report of Allied Products Corporation did issue a going-concern warning. Moreover, the stock traded in the range of \$2 to \$3 per share. There was then a turnaround of the company by 1995. In its 1995 annual report, net income increased dramatically from prior periods (to \$34 million) and there was a positive cash flow from operations (\$29 million). The stock traded in the \$25 range by the Spring of 1996.²² As with the W. T. Grant study, Dugan and Samson found that the economic realities of a firm are better reflected in its cash flow from operations.

The importance of cash flow analysis in bankruptcy prediction is supported by the study by Benjamin Foster and Terry Ward, who compared trends in the statement of cash flows components—cash flow from operations, cash flow for investment, and cash flow for financing—between healthy companies and companies that subsequently sought bankruptcy.²³ They observe that healthy companies tend to have relatively stable relations among the cash flows for the three sources, correcting any given year's deviation from their norm within one year. They also observe that unhealthy companies exhibit declining cash flows from operations and financing and declining cash flows for investment one and two years prior to the bankruptcy. Further, unhealthy companies tend to expend more cash flows to financing sources than they bring in during the year prior to bankruptcy. These studies illustrate the importance of examining cash flow information in assessing the financial condition of a company.

BOTTOM LINE

- The term *cash flow* has many meanings and the challenge is to determine the cash flow definition and calculation that is appropriate.

²¹ Michael T. Dugan and William D. Samson, "Operating Cash Flow: Early Indicators of Financial Difficulty and Recovery," *Journal of Financial Statement Analysis* (Summer 1996), pp. 41–50.

²² As noted for the W. T. Grant study by Largay and Stickney, cash flow from operations had to be constructed from the statement of changes in financial positions that companies were required to report prior to 1988.

²³ Benjamin P. Foster and Terry J. Ward, "Using Cash Flow Trends to Identify Risks of Bankruptcy," *CPA Journal* (September 1997), p. 60.

- The simplest calculation of cash flow is the sum of net income and non-cash expenses. This measure, however, does not consider other sources and uses of cash during the period.
- The statement of cash flows provides a useful breakdown of the sources of cash flows: operating activities, investing activities, and financing activities. Though attention is generally focused on the cash flows from operations, what the company does with the cash flows (i.e., investing or paying off financing obligations) and what are the sources of invested funds (i.e., operations versus external financing) must be investigated.
- Minor adjustments can be made to the items classified in the statement of cash flows to improve the classification.
- Examination of the different patterns of cash flows is necessary to get a general idea of the activities of the company. For example, a company whose only source of cash flow is from investing activities, suggesting the sale of property or equipment, may be experiencing financial distress.
- Free cash flow is a company's cash flow that remains after making capital investments that maintain the company's current rate of growth. It is not possible to calculate free cash flow precisely, resulting in many different variations in calculations of this measure.
- A company that generates free cash flow is not necessarily performing well or poorly; the existence of free cash flow must be taken in context with other financial data and information on the company.
- One of the variations in the calculation of a cash flow measure is net free cash flow, which is, essentially, free cash flow less any financing obligations. This is a measure of the funds available to service additional obligations to suppliers of capital.

Decentralized Operations and Responsibility Accounting

AGENDA

- Item 1* Explain organization planning.
- Item 2* Define levels of responsibility.
- Item 3* Discuss organization structures in terms of the functional, product, and geographical approaches.
- Item 4* Describe the advantages of decentralization.
- Item 5* Define responsibility accounting and the three types of responsibility centers.
- Item 6* Explain the principal controls of responsibility accounting systems.
- Item 7* Identify the essentials of performance reports.
- Item 8* Define controllable costs.
- Item 9* Explain the need for incentive plans and their associated goal congruence problems.

In this chapter, one of the most important responsibilities of the CFO—assuring accountability of resources—will be discussed. Before one can fully appreciate responsibility accounting, it is necessary first to discuss decentralized operations. The question of how much decentralization is desirable in a company has been a controversial subject for many years. As a company grows, upper-level management must continually reassess, rearrange, and, willingly or not, delegate many of its responsibilities among middle- and lower-level managers. At the point where it is desirable or necessary to separate physical units of the organization, upper-level management must decide first how to divide the responsibilities and the activities, and second how to coordinate the decentralized segments.

Moreover a great deal of attention has been focused on responsibility accounting and the development of reports that measure how assigned responsibilities are being carried out. Responsibility accounting, in a nut-

shell, is the designation of decision centers—referred to as responsibility centers—and the development of a system of data collection and analysis of financial information to evaluate the performance of these responsibility centers. These factors are discussed in this chapter.

ORGANIZATION STRUCTURES AND CONCEPTS

A business organization is a combination of people and resources brought together to fulfill an economic objective. Organization planning is essentially determining how these elements will be coordinated to achieve specific company objectives. Corporate objectives are accomplished only through people. Employees, particularly professional employees, identify themselves with company objectives only to the extent that their own objectives are also achieved. This vitally important principle from the behavioral sciences is called *goal congruence* and is, unfortunately, very difficult to achieve in an organization. Therefore, in any organizational arrangement the personal needs and aspirations of employees must be carefully considered if the organization's overall goals are ever to be fully achieved.

The first consideration in developing organization structures is to decide which way and to what extent the activities shall be grouped. The major approaches usually are functional, product, and geographical. The choice of approaches depends upon the nature of the activities involved and upon which activities may need to be more centralized. In most cases there will be some overlap; some functions will be organized on one level, some on another. The sales function may be established at the top on a functional basis, but at the field level it may be organized on a geographical basis, with district and regional offices, or it may be set up at some levels on a customer basis (retail users, industrial users, etc.). In practice, the problem is to find the best combination of approaches.

In the *functional approach*, the company is organized according to such major functions as production, marketing, personnel, and finance. Generally, control is centralized at the vice president level. The production employees, for example, report upward from the lowest operating level to the vice president of production level. The disadvantage is that key decisions must be made at the top, which is usually a time-consuming process.

In the *product approach*, the functional responsibilities are combined according to products (or groups of products) and are established accordingly. The principal advantage is the more effective coordination of activities relating to products (or groups of products).

In the *geographical approach*, sometimes called the *regional approach*, the responsibilities are grouped according to geographical areas. Managerial

responsibilities will encompass all functions and all products in a particular geographical area. The benefits of this grouping lie in the better coordination of all operations in a particular geographical area.

EXAMPLES OF TYPES OF ORGANIZATION STRUCTURE AND RESPONSIBILITY REPORTING

The principal approaches (functional, product, and geographical) to grouping organization activities and the related reporting of responsibilities are illustrated below. For each approach, an organization chart to show the arrangement of activities and cost reports to illustrate the manner of reporting costs at each level are included. Generally, the higher the level, the more condensed the report. For example, the report to the president would show the expenses associated with the president's office according to category of expense and then the total for each division or group that reports directly to the president. The president would direct any questions concerning the costs of a particular group to the vice president responsible for that division.

In presenting charts or reports for responsibility accounting, usually one of two methods is used. The first method starts from the top and goes down, that is, with level 1 as the president, down to level 4, the department supervisor. The second method starts from the bottom and goes up, that is, with level 1 as the department supervisor, up to level 4, the president. The following charts and reports use the first method, with level 1 as the president. Later in the chapter the second method will be presented in the discussion of responsibility accounting.

The levels of responsibility should be well defined and should be consistent for all levels. At *level 1* is the office of the *president*, who is responsible for all operations, assuming that the president is the chief executive officer. In some companies the chairperson of the board of directors is the chief executive officer. At *level 2* are the *vice presidents*, each of whom is responsible for a division. They report to the president. In a manufacturing firm, at *level 3* are the *plant managers*, each of whom is responsible for a plant in one of the divisions. They report to a divisional vice president. At *level 4* are the *supervisors*, each of whom is responsible for a department in one of the plants. They report to the plant manager. This could be carried still further to a lower level, such as a cost center in a department.

Costs may be classified in a number of ways, depending on the company's wishes. If there are many divisions and plants, it is important that there be a uniform system of accounts so that the cost classifications among units are comparable and the cost of an individual item in one plant can be compared with the cost of the same item in another plant. In some cases only

controllable costs (discussed later in this chapter) are detailed; in others, the company may include some or all noncontrollable costs in the report. Thus, inclusion of various costs in reports will vary greatly among companies.

For each approach, the relationships of the various levels and the reporting responsibilities of those levels are as shown below.

Functional Approach

Let's look first at the functional approach. As can be seen in Figure 11.1, all vice presidents (level 2) report to the president (level 1). For easier understanding only three divisions are used: marketing, manufacturing, and finance. In practice there would ordinarily be more divisions, but the principle remains the same. On the reporting side, the operations of all divisions of the company are condensed in the president's report. Shown are the costs of the president's office, including the president's salary¹ and various other administrative expenses. Following are shown the totals only of the divisions, which are marketing, \$1,150,000; manufacturing, \$1,410,000; and finance, \$595,000.

The operations of the manufacturing division will illustrate level 2. As can be seen, the total for the manufacturing division agrees with the total shown in level 1. The manufacturing plants in this division produce three distinct products—commercial products, consumer products, and military products. The costs of running the manufacturing vice president's office amount to \$90,000, and the costs for the individual plants are commercial, \$170,000; consumer, \$520,000; and military, \$630,000. The total is \$1,410,000. The other plants would report similarly.

The next level would be manager (level 3). The consumer products plant will illustrate this, although any other plant would do as well. Here the total is \$520,000, which agrees with the total shown in level 2. The manager's office cost is \$65,000, and the department costs are as follows: treating, \$155,000; subassembly, \$160,000; and assembly, \$140,000.

The next level would be supervisor (level 4). For illustration, the treating department will be used. It has a total cost of \$155,000, which agrees with the total shown in level 3. The cost of the supervisor's office is \$30,000, and the amounts for the cost centers are cost center 1, \$50,000; cost center 2, \$35,000; and cost center 3, \$40,000.

In addition to the summary statements shown above for the various levels, there would be a cost statement for each unit or cost center according

¹ The president's salary is included as a cost controllable by the president if, and only if, the president is responsible for setting his or her own salary. Otherwise, the president's salary would be a noncontrollable cost and omitted from the report.

FIGURE 11.1 Functional Approach

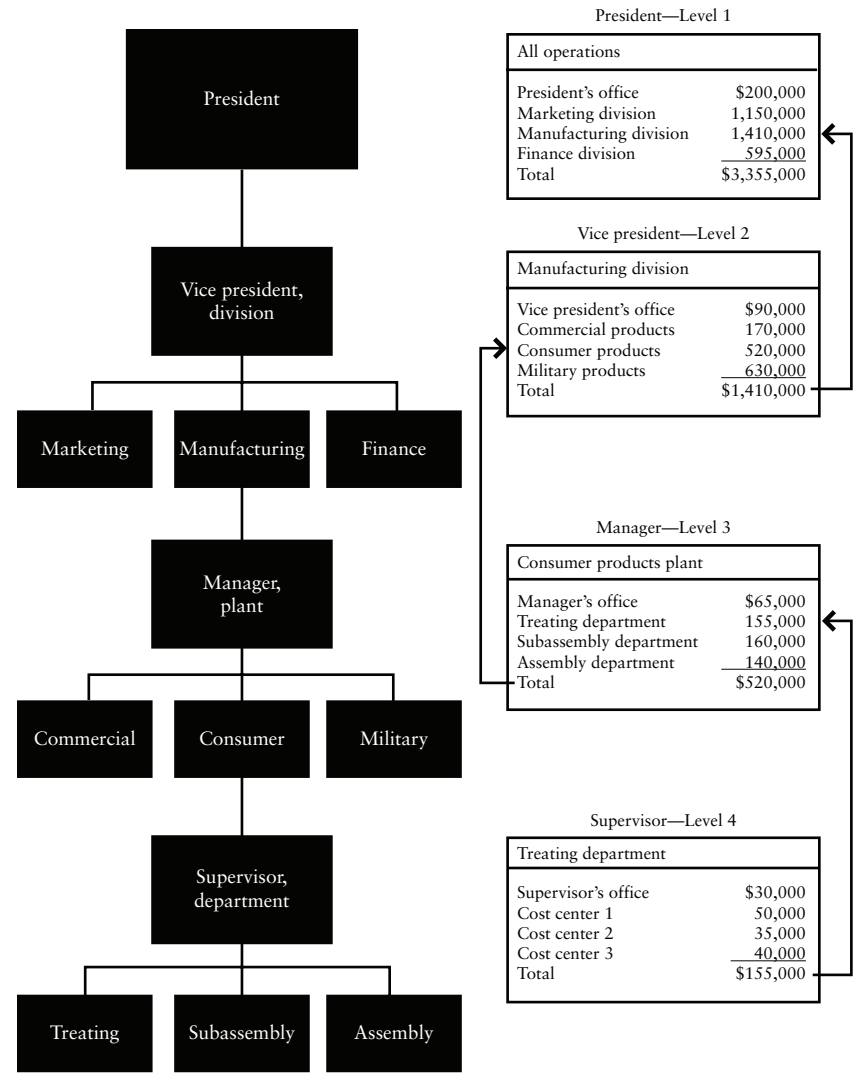

to the nature of the cost, such as supervision or fringe benefits. For example, the controllable costs for level 5, cost center 1, might appear as follows:

| Cost Center 1—Level 5 | |
|--------------------------------|-----------------|
| Schedule of Controllable Costs | |
| Supervision | \$20,000 |
| Fringe benefits | 5,000 |
| Machine setup | 3,000 |
| Rework | 8,000 |
| Supplies | 5,000 |
| Other costs | <u>9,000</u> |
| Total | <u>\$50,000</u> |

Product Approach

Under the product approach (Figure 11.2), the total for all operations (level 1) is the same as before but the organizational grouping is entirely different from that under the functional approach. All the activities of the company can be related to either chemical, drug, or paint operations. Here the drug division total (level 2) is \$1,430,000; it is the largest division shown on the president's report (level 1). In the report for the vice president (level 2), the drug division is responsible for three manufacturing plants, which make the following distinct professional supplies: medical, pharmaceutical, and hospital. As can be seen, the level 2 report shows a total cost for the pharmaceutical plant of \$575,000. The other two plants would present similar reports.

The manager's report (level 3) shows that there are also three separate departments in the pharmaceutical plant: mixing, bottling, and packaging. The total for the level 3 report of \$575,000 agrees with the total shown on the level 2 report.

In the supervisor's report (level 4) it can be seen that there are three separate cost centers in the bottling department, making up the total of \$205,000, which is shown on the level 3 report. The next level would show one of the cost centers, but the principle should now be apparent.

Geographical Approach

Under the geographical approach (Figure 11.3) the total costs for all operations are the same as in the functional approach and the product approach, but the subsidiary levels vary considerably. Instead of being arranged ac-

FIGURE 11.2 Product Approach

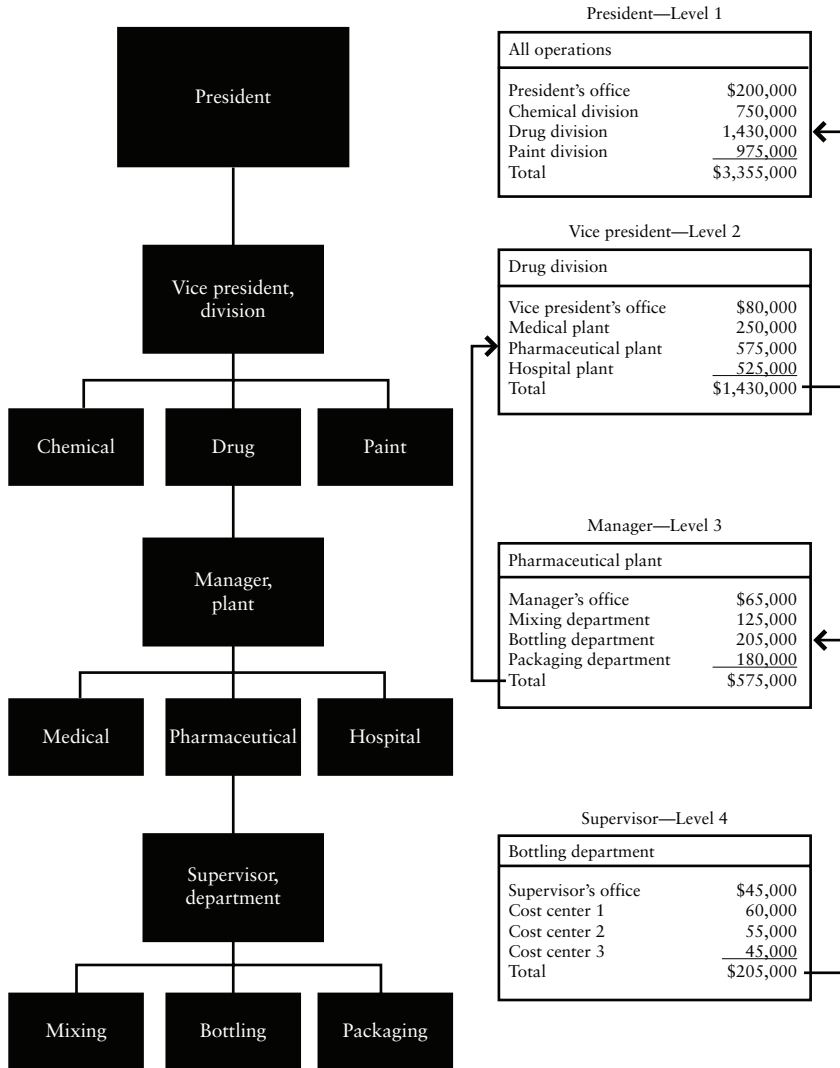
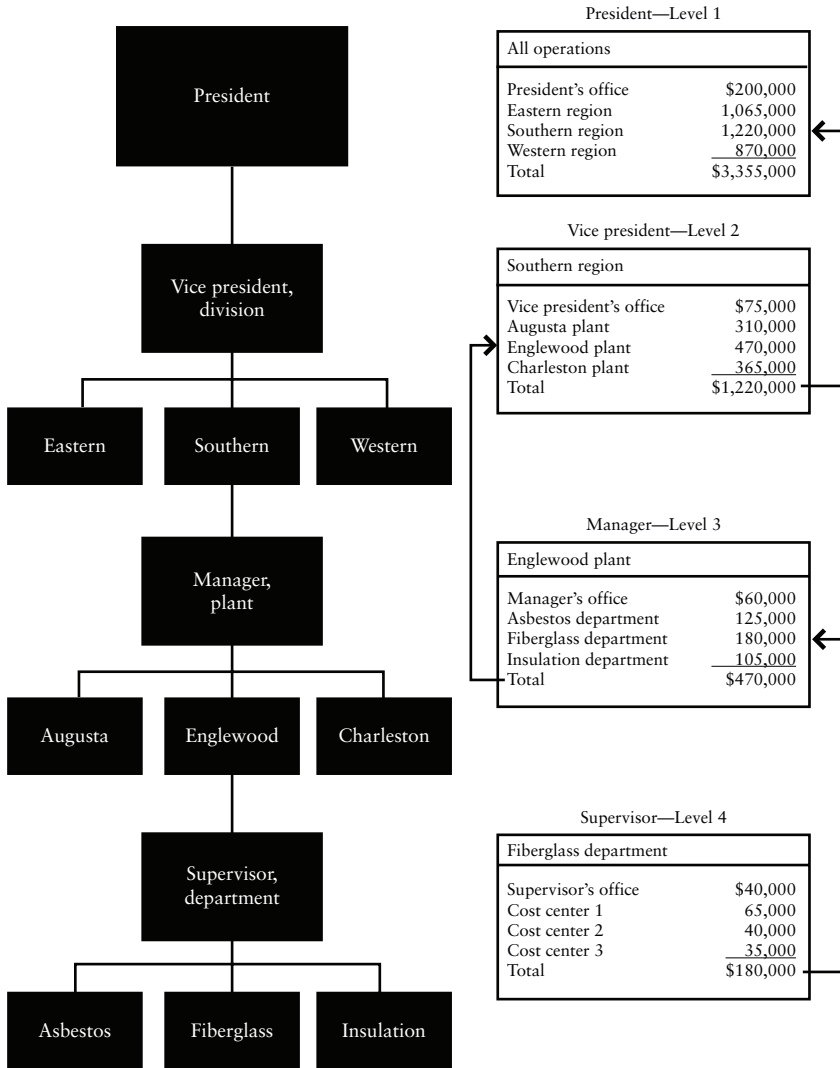

FIGURE 11.3 Geographical Approach



ording to function or product, the structure is arranged according to geographical region. Companies that have products that are very bulky and costly to transport may have manufacturing and warehousing facilities in the same region to minimize shipping costs. Thus, a company may have an Eastern division, a Southern division, and a Western division. This arrangement could serve customers in the respective regions much more efficiently. In the Southern region, level 2, there are three plants: Augusta, GA, Englewood, FL, and Charleston, SC. Each plant may have its own warehouse, or there may be a large single warehouse, centrally located, from which all divisional shipments may be made.

In level 3 the total of \$470,000 for the Englewood plant ties into the total for that plant shown in the level 2 report. The Englewood plant has three departments making distinct products composed of the following materials: asbestos materials, fiberglass materials; and insulation materials. The total for the fiberglass department of \$180,000 ties into the applicable amount shown in the level 3 report.

DECENTRALIZATION PROBLEMS

Determining the extent of authority and responsibility that should be decentralized is a problem that is common to all the approaches to grouping activities. Generally, the degree of decentralization will be greater under the product approach, and in many instances it will be a practical requirement, as in cases of foreign locations. The extent of decentralization will largely depend on the ability of individuals to be responsible for lower-level decisions, the feasibility of coordinating the various operations, and the impact of the decentralized decisions on other units of the company.

Advantages of Decentralization

The principal advantages of decentralization are:

- Upper-level managers will have more time to devote to nonroutine and long-term planning instead of being burdened with daily decisions.
- Decision making will be distributed among more managers so that each person should have sufficient time to give matters maximum attention.
- Better control can be achieved, as managers can respond more quickly to problems in need of correction.
- Managers are more motivated because they have more input and control over matters that affect their performance.

- Managers are more likely to exercise initiative by searching for the least costly input. The continuous comparison of internal and external costs tends to tighten control over internal costs such as the “pricing” of intracompany transfers (see Chapter 13).
- Decentralization acts as an unintentional training program in that as managers become more proficient in decision making, they become more qualified for higher-level management positions.

The greater the degree of decentralization, the greater the need for coordination in order to obtain benefits for the company as a whole. Designing and implementing a managerial accounting information pool can improve intracompany communication between management and its internal environment and improve intercompany communication between management and its external environment.

Where the operating units have substantial independence, there may actually be destructive competition among the units of the organization for certain limited resources. The costs of decentralization are minimized when the decentralized unit:

- Can establish its own goals independent of the goals of other units.
- Does not depend on other units for its raw materials.
- Does not depend on other units for its sales.
- Does not compete externally with other units for limited resources.
- Does not compete internally for limited capital or research appropriations.

Cost of Decentralization

The principal cost of decentralization is probably the very thing that makes it most beneficial, that is, the delegation of responsibility. The decentralization concept can be carried to the extent that the goals of the organization as a whole and the goals of the decentralized unit do not conform (i.e., lack of goal congruence). For example, the manager of a unit may take certain actions that benefit the unit but may not be beneficial to the company as a whole.

RESPONSIBILITY ACCOUNTING

Most cost accounting systems were originally designed to accumulate and distribute costs for product or inventory purposes and for general cost control. The accounts were set up to record product costs and period costs in

accordance with the needs of the income statement and the balance sheet. This system works well in showing where resources are consumed, but not as well in determining who was responsible for incurring the cost and how to take prompt corrective action if it is deemed necessary. The remainder of this chapter will be concerned with an accounting system directed toward individuals, that is, who authorized the expense rather than what the expense was. It will be necessary to deviate from generally accepted accounting principles in the preparation of responsibility accounting reports wherein the guiding principle is “controllability.” Responsibility accounting is definitely a different approach to cost accumulation, with the emphasis shifting from product costing to performance evaluation.

Responsibility Accounting Defined

Before proceeding further, the term *responsibility accounting* should be defined. Various definitions appear in the accounting literature but they all contain the essential points included in the following definition: “Responsibility accounting is a system designed to accumulate and report costs by individual levels of responsibility. . . Each supervisory area is charged only with the cost for which it is responsible and over which it has control.”² Responsibility accounting is often mislabeled a “control” technique. To the contrary, responsibility accounting is both a “planning” and a “control” technique. In Chapter 23 we will see that a master budget is prepared periodically and represents an overall plan of operation encompassing all aspects of the organization such as production, marketing, administration, and finance. The master budget is usually prepared (in a decentralized company) through the direct participation of responsibility center managers. In essence, the master budget represents what each responsibility center manager perceives as his reasonably attainable goal.

Essentials of Control

No matter how well designed a system is, it will not be successful unless it has the support of the people who operate the system. The system must be based on “people responsibility,” as it is people who incur costs and should be held accountable for each expenditure. The principal controls in the incurrence of costs are:

- An organization plan that establishes objectives and goals to be achieved.

² John A. Higgins, “Responsibility Accounting,” *Arthur Andersen Chronicle C*, 1952.

- The delegation of authority and responsibility for cost incurrence through a system of policies and procedures.
- Motivation of individuals by developing standards of performance together with incentives.
- Timely reporting and analysis of exceptions between goals and performance by means of a system of variance reporting.
- A system of appraisal or internal auditing to ensure that unfavorable variances are clearly shown and that corrective action and follow-up are applied.

Organization Structure

Before a responsibility accounting system is designed, there must be a thorough study of the organization. The lines of authority must be clarified before the responsibility system is completed. Where authorities and responsibilities have been properly established, there will be a structure of management levels, each of which will have a *responsibility center* or sphere of responsibility and the authority to make decisions within the established sphere. Responsibility accounting will provide the means of tracing costs to individual managers primarily responsible for incurring the particular costs. Generally, the system should be set up so that costs can be automatically traced to the individual at the lowest organization level responsible for the item. Managers are not subject to day-to-day monitoring of their decisions but are held accountable in their overall performance by means of responsibility accounting.

Responsibility Centers

As noted above, when an organization is divided into segments with managers having responsibility over specific areas (activities), the segmented areas (activities) are known as responsibility centers. Three types of responsibility centers are common to most responsibility accounting systems—the cost center, the profit center, and the investment center.

A *cost center* is a segment of an organization that has been assigned (delegated) control over only the incurrence of costs. A cost center has no control over sales or marketing activities.

A *profit center* is a segment of the organization that has been assigned (delegated) control over both the generation of revenues and the incurrence of costs. A manager of a unit or division that has control over both revenues and costs will attempt to maximize profit. Generally, the profit center is the principal means of implementing decentralization. However, it is possible to have profit centers in highly centralized companies and cost centers in highly

decentralized companies. In fact, it is common to have both centralized sections and decentralized sections in one company. Generally, certain limitations are placed on a profit center by corporate headquarters. For example, although profit center managers may have control over sales and costs, they do not have control over the amount of investment in profit center assets. Decisions on investment projects are generally made by an upper-level management committee.

An example of a profit center would be a division under a vice president who has responsibility for sales and costs. For example, in Figure 11.2, the vice president for the drug division would generally have control over sales and costs. In Figure 11.3, the vice president of the Southern division would also have control over sales and costs.

An *investment center* differs from a profit center in that it has control not only over the generation of revenues and the incurrence of costs but also over the acquisition of investment center assets. Clearly, the manager of an investment center has greater responsibility than either a cost center manager or a profit center manager. As a consequence, the investment center manager will be held to a much greater degree of accountability for his or her performance. While the other two types of responsibility center managers, no doubt, utilize assets in the performance of their duties, only the investment center manager is vested with the authority to make asset acquisition decisions. See Chapters 14, 15, and 16 for a discussion of the complexities inherent in capital budgeting decisions to fully appreciate the acquisition responsibilities of an investment center manager with respect to long-lived assets of substantial cost.

Responsibility Accounting System

One of the first requirements in developing a good responsibility accounting system is a sound organization structure, which is usually shown by means of an organization chart. In some cases, the installation of a responsibility accounting system has uncovered weaknesses in the organization structure that had to be corrected before the accounting system could be established. The next step is to develop a chart of accounts that will collect data, not by products or types of expense, but by the three types of responsibility centers noted above.

To illustrate, consider the Columbia Manufacturing Company, which produces and sells appliance parts. Costs are gathered for each cost center as needed; some are reported daily, others weekly and monthly. There are four levels of responsibility in the Columbia Manufacturing Company, as shown in Figure 11.4.

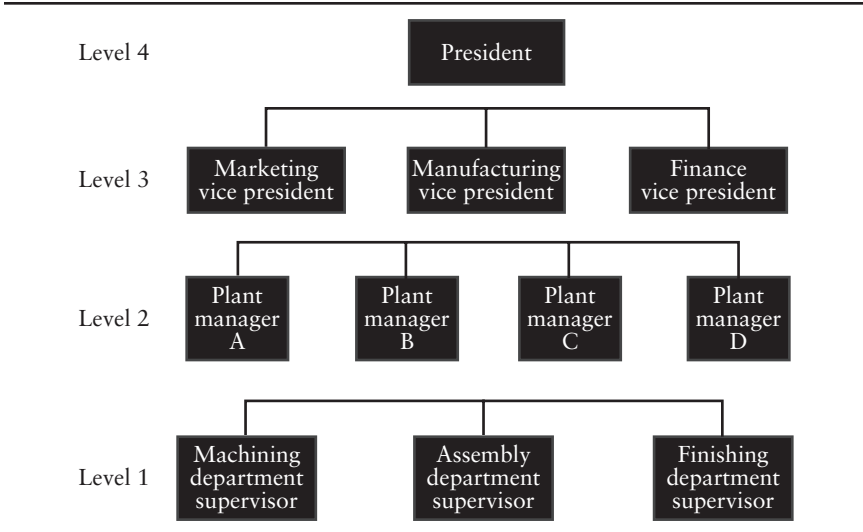
FIGURE 11.4 Levels of Responsibility**Level 1: Departments**

In each plant there are three production departments: machining, assembly, and finishing. There are also service departments such as engineering and purchasing whose costs are allocated to production departments for product costing purposes. However, they are *not* allocated to production departments for responsibility accounting purposes.

Level 2: Plants

The company has four manufacturing plants, A, B, C, and D, which are all located within a radius of 20 miles of headquarters. The headquarters for the company is located in Plant C.

Level 3: Vice Presidents

The company has three vice presidents to oversee the functions of marketing, manufacturing, and finance. There are staff assistant vice presidents but they are not needed on the chart.

Level 4: President

The company president is also the chief executive officer. There are four staff assistants, but they are also not needed on the chart.

Responsibility Accounting Reports

Responsibility accounting reports are prepared according to responsibility levels shown in the organization chart. At each level, the direct costs incurred by the unit manager are listed, and then the costs incurred by each of the subordinate unit managers are shown. Thus, at level 4 the report would include the total cost for the company, that is, the cost of the president's office plus the costs of the immediate subordinates, the vice presidents.

As can be seen in Table 11.1, the performance reports for the month of March 200X have been presented on four levels: level 1 for the assembly department supervisor; level 2 for the plant manager—plant C; level 3 for the vice president—manufacturing; and level 4 for the president. These reports are discussed in detail below.

Level 1: Assembly Department Supervisor

The costs listed in detail are those *directly controllable* by the supervisor. Direct materials and direct labor are charged to the department at standard cost; the direct materials price variance, as you would expect, is charged to the purchasing department. The other three variances (direct materials usage variance, direct labor efficiency variance, and direct labor rate variance) are the responsibility of the assembly department supervisor. They are analyzed and investigated if they are significant. The budgeted cost for the department was \$15,000 for the month, with a total unfavorable variance of \$400. These amounts are also shown in a year-to-date report, similar to the current-month report.

Level 2: Plant Manager—Plant C

In the report, the plant manager's office cost is shown first, then the totals for each of the plant's three departments. These totals are taken from the reports prepared by the departments for which the plant manager is responsible. Note that the budgeted and actual amounts for the assembly department as described above are listed in the plant manager's report. The budgeted cost for the plant was \$70,000 for the month with a total unfavorable variance of \$1,300.

Level 3: Vice President—Manufacturing

The cost of the office of the vice president—manufacturing is shown first on the report, then the totals for each of the plants for which the vice president is responsible. These totals are taken from the reports prepared by the

TABLE 11.1 Responsibility Reports, Controllable Costs, March 200X

| | Current Month | | Variance |
|---|------------------|------------------|----------------|
| | Budget | Actual | |
| <i>Level 4: President:</i> | | | |
| President's office | \$25,000 | \$24,000 | \$(1,000) |
| Vice president—marketing | 125,000 | 128,000 | 3,000 |
| Vice president—manufacturing | 165,000 | 164,800 | (200) |
| Vice president—finance | <u>50,000</u> | <u>49,000</u> | <u>(1,000)</u> |
| Total controllable cost | <u>\$365,000</u> | <u>\$365,800</u> | <u>\$800</u> |
| <i>Level 3: Vice president—manufacturing:</i> | | | |
| Vice president—manufacturing office | \$10,000 | \$8,000 | \$(2,000) |
| Plant A | 20,000 | 21,000 | 1,000 |
| Plant B | 25,000 | 23,500 | (1,500) |
| Plant C | 70,000 | 71,300 | 1,300 |
| Plant D | <u>40,000</u> | <u>41,000</u> | <u>1,000</u> |
| Total controllable cost | <u>\$165,000</u> | <u>\$164,800</u> | <u>\$(200)</u> |
| <i>Level 2: Plant manager—plant C:</i> | | | |
| Plant manager's office | \$20,000 | \$20,500 | \$500 |
| Machining department | 10,000 | 9,400 | (600) |
| Assembly department | 15,000 | 15,400 | 400 |
| Finishing department | <u>25,000</u> | <u>26,000</u> | <u>1,000</u> |
| Total controllable cost | <u>\$70,000</u> | <u>\$71,300</u> | <u>\$1,300</u> |
| <i>Level 1: Assembly department supervisor:</i> | | | |
| Direct materials | \$8,000 | \$8,500 | \$500 |
| Direct labor | 5,000 | 4,400 | (600) |
| Machine setup | 1,000 | 1,300 | 300 |
| Rework | 500 | 700 | 200 |
| Supplies | 200 | 100 | (100) |
| Other | <u>300</u> | <u>400</u> | <u>100</u> |
| Total controllable costs | <u>\$15,000</u> | <u>\$15,400</u> | <u>\$400</u> |

() = Variance favorable

plant managers reporting to the vice president—manufacturing. The total amounts for plant C, as described above, are listed in the vice president—manufacturing report. The budgeted cost for all plants and for the vice president's office was \$165,000 for the month, with a favorable variance of \$200. These amounts are carried to the president's report.

Level 4: President

In the president's report, the cost of the office is shown first, then the totals for each of the subordinate vice presidents. The totals are taken from the reports of the functional areas for which the various vice presidents are responsible. The amounts for the vice president—manufacturing as described above are listed in the president's report. The budgeted cost for all operations of the company was \$365,000 for the month, with a total unfavorable variance of \$800.

CONTROLLABLE COSTS

In the reports presented in Table 11.1, the only costs shown are those that can be controlled by the responsibility unit managers. This approach is preferable and is based on the premise that managers should not be charged with costs over which they have no control. Otherwise, the planning, control, and decision-making benefits of having a responsibility accounting system will be negated. However, some companies still insist on showing separately the costs "allocated" from other departments. They point out that although managers are not charged with control over these allocated costs, they should be aware of the total cost of the responsibility unit for which they are responsible.

Controllable costs are those that may be directly influenced by unit managers in a given time period. When a manager exercises the authority to acquire and/or use an item, its cost will be considered to be controllable by that manager. However, the controllability generally is not the complete responsibility of one person; in many companies there may be varying degrees of influence by others. It could be said that all costs are controllable at some level at some time. The production manager does not have complete control over direct materials costs. That is, the price at which materials are purchased is controllable by the purchasing department. If the price variance is excluded (as it should be), the production manager then has control primarily over usage. However, there may be excess usage or spoilage in a particular period that should not be charged to the production manager. For example, in a period of scarcity, the purchasing agent might not have

been able to acquire materials from the regular supplier and had to purchase them from a new supplier. During production it was found that the materials were of inferior quality in certain respects such as tensile strength, and excess spoilage resulted. The responsibility accounting report showed that the production manager had excess spoilage, for which he would ordinarily be held accountable. This problem could have been averted if independent quality tests had been ordered by the purchasing department, resulting in the purchasing department being charged with the cost of spoilage and not the production department.

COSTS OF SERVICE DEPARTMENTS

The costs incurred by service departments are allocated to production departments in order to arrive at product costs. The principles of responsibility accounting are equally applicable to service departments as well as to producing departments. The purchasing department, for example, must be as cost conscious as the production department, and only costs properly chargeable as purchasing expenditures should be included in the responsibility accounting reports of the purchasing department.

Within the context of responsibility accounting, there may be some justification for allocating selected service department costs to producing departments. That is, if an internally provided service may be considered in lieu of an outside “purchase” by the production department, the cost could be construed as controllable by the production manager. For example, when a maintenance department employee repairs a machine in a producing department, it may be viewed as equivalent to incurring the cost of a repair from an outside company. If maintenance job 150 called for the repair of a machine in the drill press department requiring 4 hours, the allocated cost would be 4 hours times the rate per maintenance labor hour. Assuming maintenance labor is \$20 per hour and maintenance factory overhead is 100% of direct labor cost, the total rate per hour would be \$40. The total to be allocated to the drill press department for job 150 would be \$160 (\$80 direct labor + \$80 factory overhead). One can make a very strong argument that the \$160 even though it is provided by a service department is, in reality, a cost controllable by the drill press department. Obviously, the boundaries of cost controllability, the very essence of a responsibility accounting system, are not always clearly delineated. The CFO or accounting staff should exercise their knowledge, experience, and judgment in the determination of which department should bear the ultimate responsibility for the controllability of cost. It may even be desirable for the benefit of the company as a whole if multiple departments are charged with a dual accountability for cost incur-

rence in terms of providing services (service departments) and consuming services (production departments).

EXECUTIVE INCENTIVE COMPENSATION PLANS AND DYSFUNCTIONAL DECISION MAKING

Responsibility accounting as described in this chapter is made increasingly necessary by the growing complexities inherent in organizational decentralization wherein the authority to make decisions and the responsibility for their outcomes are vested in a multiplicity of responsibility center managers. A crucial element in the success or failure of a responsibility accounting system is the intensifying use or misuse of executive incentive compensation plans (EICPs). The widespread reliance on EICPs will be used to illustrate their potentially dysfunctional characteristics if poorly conceived incentive schemes are adopted.

In theory, EICPs serve to motivate members of the organization by offering rewards for good performance and penalties for bad performance. EICPs should be judged to be successful if, and only if, they strengthen the bond between goal congruence and employee effort. Correspondingly, they should be judged to have been a failure if they lead to dysfunctional decision making wherein the benefit to one responsibility center is more than offset by the cost to the organization as a whole.

Theoretical Overview—Principal–Agency Theory

A full appreciation of decentralization, responsibility accounting, and the need for EICPs rests on an application of *principal–agency theory*. The focus here is on the relationship between managers within a decentralized organization. In essence, a principal (i.e., an upper-level manager) hires an agent (i.e., a middle-level manager) to perform a service necessitating the delegation of decision-making authority from the principal to the agent.

If an agent is not properly compensated for services rendered, the agent may not be motivated to make decisions that are most beneficial to the organization as a whole. In order to encourage an agent to take actions that are in the organization's best interests, a principal introduces an incentive scheme. As Kaplan and Atkinson point out:

Incentive compensation plans are designed to create a commonality of interest between the principal (owners) and the agents (managers). But because of differences in risk attitudes, the existence of private information (managers know more than the owners about the

environment and their actions), and limited or costly observability, some divergence of interest will always exist between the principal and the agents.³

Agency cost represents the measurable value of this divergency and includes the cost of the EICP, the cost of monitoring the performance of agents, and the difference between what the agent achieved (in the agent's own selfish best interest) and what the agent could have achieved in the best interests of the organization. Agency cost is an unavoidable outcome of decentralization and the principal–agency relationship. To the greatest extent possible, the board with the assistance of the CFO should build into the organization's responsibility accounting system a means by which actual agency cost is identified, accumulated, and compared to a predetermined level of acceptability. In so doing, they must not lose sight of the need for EICPs, namely, to encourage management performance that would otherwise not be achieved by allowing selected members of the organization to participate financially or otherwise in the results of their accomplishments.

Executive Incentive Compensation Plans

EICPs are a crucial element in the management control process. The EICPs that are adopted must encourage goal congruence—an individual's personal goals coinciding with the overall goals of the organization. The following two examples based on factual events will illustrate how EICPs, if flawed, can lead to dysfunctional decision making and a lack of goal congruence. Whatever compensatory measures are selected, they must not be initiated at the expense of the *autonomy* dimension of organizational decentralization, such that managers, delegated authority to make decisions, are held accountable for their performance (and are properly rewarded or penalized).

Example 1

A classic example of a lack of goal congruence can be discerned from the following real-life incentive scheme that was built into the contract of a prominent National Football League quarterback. The quarterback's agent negotiated a significant monetary bonus based exclusively on the percentage of passes successfully completed (i.e., number of passes caught divided by number of passes attempted). As a direct consequence of this incentive scheme, whenever the quarterback was pressured by the onrushing defensive team, he would allow himself to be tackled or sacked ("eating the ball"

³ Robert S. Kaplan and Anthony A. Atkinson, *Advanced Management Accounting*, 2nd ed. (Englewood Cliffs, NJ: Prentice-Hall, 1989), p. 722.

in football jargon); this would result in a substantial loss of yardage making it that much more difficult for the offensive team to achieve a first down and thereby sustain its offensive scoring drive. The media were quick to criticize the quarterback for not having elected to “throw the ball away,” which would have at least avoided the substantial loss of yardage and not unduly penalized the offensive scoring drive.

Can you readily see why the quarterback chose to eat the ball instead of throwing it away? One can only guess that the quarterback was unduly motivated by his EICP. By *not* throwing the ball away, which would have been in the best interests of the football team, the quarterback was acting in his own selfish best interest to protect his pass-completion percentage. This lack of goal congruence has led to an unwarranted inflation in the personal statistics of the quarterback, but it has also kept the team from realizing its fullest potential (i.e., a trip to the Super Bowl).

For an EICP in the context of football to be most effective, namely, achieve goal congruence, it must be based on each player’s contribution to the overall success of the team. A system of individual player incentives provides little, if any, motivation for a player to think of the overall well-being of the team. Rather, players tend to focus narrowly on their own performance, often at the expense of the team’s overall welfare.

A better incentive scheme would tie a player’s efforts to the effect it has on the welfare of the entire team. The underlying concept of a good EICP, whether it be for a football team or a business organization, successfully molds players or executives “into a cooperative constructive group but without destroying individual ambition and initiative.”⁴

Thus, it appears that the use of *group-based EICPs* for lower-, middle-, and upper-level managers will refocus on the behavioral consequences of joint managerial performance vis-à-vis the overall objectives of the organization.

Example 2

Another important reason for a lack of goal congruence is the potential for managerial abuse of accounting data when absolute annual cutoff levels are used in the determination of the amount of incentive compensation. By way of illustration, assume that a profit center manager’s annual bonus is based on achieving a controllable income greater than \$200,000 in 200X. If the profit center manager realizes that a bonus will not be earned in 200X because the likely controllable income will be approximately \$170,000, he may be strongly motivated, contrary to the best interests of the organization as a whole, to decrease current period profitability further; that is, the

⁴ Kaplan and Atkinson, *Advanced Management Accounting*, p. 720.

manager could conceivably in conjunction with the cost center's managerial accountant (1) shift the recognition of, for example, \$5,000 of future controllable costs to the current period and (2) defer the realization of, for example, \$1,000 of current controllable revenues to the next year to set up *artificially* the opportunity for an "unfairly" and "deceptively" earned bonus in the next year. The profit center manager's \$36,000 unfavorable "performance evaluation variance" is calculated in Table 11.2.

To avoid this perfectly understandable and yet untenable situation, the \$36,000 unfavorable performance evaluation variance should be reduced to a *real* \$30,000 deficiency and communicated to the controller by the accountant assigned to the cost center (with a \$6,000 "accounting deficiency" carried forward into the next period). Therefore, next year's bonus would be based on the difference between next year's actual controllable income and next year's projected controllable income plus the \$6,000 "accounting deficiency carryforward."

This illustration also suggests the need for an EICP with both a short- and a long-term perspective. That is, a current year controllable income target could be established for a profit center manager that, if achieved or surpassed, would result in a small temporary reward. In addition, a 3- to 5-year controllable income target could also be established for the same profit center manager that, if achieved or surpassed, would result in a large permanent reward (such as a possible promotion with greater managerial responsibilities and compensation).

Some Conclusions

The principal-agent relationship within a decentralized organization using a responsibility accounting system leads to a number of important and complex managerial accounting issues. We have explained how dysfunc-

TABLE 11.2 Calculation of Performance Evaluation Variance

| | |
|--|----------------------------|
| Projected controllable income | \$200,000 |
| Less artificially manipulated controllable income: | |
| Actual controllable income | \$170,000 |
| Less: Current recognition of future controllable costs | (5,000) ^a |
| Less: Deferral of current controllable revenue | <u>(1,000)^a</u> |
| Artificially manipulated controllable income | <u>164,000</u> |
| Unfavorable performance evaluation variance | <u>\$36,000</u> |

^a The "accounting deficiency" equals \$6,000 and consists of \$5,000 of future controllable cost plus \$1,000 of current controllable revenue.

tional decision making can often be traced to the use of EICPs wherein the emphasis is unwittingly placed on short-run individual performance at the expense of long-run organizational objectives. The next two chapters will examine performance measurement issues caused by the principal-agent relationship.

There are some theoretically possible remedies to minimize agency cost such as (1) having the amount of incentive compensation based on organizational and not individual achievement, called a *group-based EICP*, and (2) the judicious use, if it becomes necessary, of an “accounting deficiency carryforward” to negate the manipulation of responsibility center information in an absolute cutoff-based EICP.

Obviously, for these two suggestions to be viable, a very rich monitoring system is a prerequisite. Anything less encourages dysfunctional decision making and exacerbates the problem. For example, the accounting deficiency carryforward may be unworkable; the numbers are potentially unknowable and assume an information system that “gives the truth.” In theory, a flawed executive incentive compensation system should be corrected. In fact, if a pure system existed, then there would not ever be a need for the flawed one. However, when you really consider the underlying logic presented above, there is no such thing as a perfect incentive compensation system that will foster complete goal congruence. The lack of perfect and complete information essentially guarantees this result. The best that a CFO can do is to continually explore, hypothesize, and test ideas to minimize the toxic consequences of incentive systems that inevitably breed dysfunctional behavior.

BOTTOM LINE

- As organizations have grown in size and are more widespread in operations, the burden on central management has greatly increased.
- In order to help lessen the enormous and virtually unmanageable pressures, decision-making responsibility in many cases has been decentralized, in line with the decentralization of the physical properties of the organization; decision making is thus located closer to operations that need to have more detailed and timely information than is generally available at a centralized headquarters. This allows decisions to be made at lower levels and helps in training subordinate managers for higher-level responsibilities and gives higher-level executives more time to concentrate on overall company policy-making decisions.
- A change to a responsibility accounting system does not require any significant change in accounting theory or generally accepted account-

ing principles. It involves primarily a change in emphasis, from product costing to responsibility costing. Thus, revenues and expenses are accumulated and reported by levels of responsibility so that actual cost can be controlled by the appropriate manager responsible for its incurrence by comparison with budgeted cost.

- The key advantage of a responsibility accounting system is its emphasis on evaluating a manager's performance. Also, information is made more readily available for prompt action to investigate and correct deviations (variances) from established company objectives.
- A necessary addition to the performance evaluation process in a decentralized organization is the implementation of a system of incentive plans.
- Incentive plans act as a means of motivating (1) nonmanagerial-level employees through wage-incentive plans and (2) lower-, middle-, and upper-level managers through executive incentive compensation plans to achieve or surpass budgeted expectations.
- As one of the key elements in the management control process, wage-incentive plans and executive incentive compensation plans must be designed to encourage individuals to take actions that are in the best overall interests of the organization, namely, goal congruence.

Responsibility Center Performance Evaluation

AGENDA

- Item 1* Describe the bases of comparison used for performance evaluation.
- Item 2* Illustrate the use of the flexible budget in measuring performance.
- Item 3* Determine alternative courses of action and indifference points in cost center decision making.
- Item 4* Define a controllable income statement for the evaluation of profit center performance.
- Item 5* Compute the contribution margin ratio as part of segment-oriented profit center decision making.
- Item 6* Define and compute return on investment, investment turnover, and the earnings ratio.
- Item 7* Identify the strengths and weaknesses of return on investment.
- Item 8* Define residual income.
- Item 9* Apply return on investment and residual income in investment center decision making.
- Item 10* Describe the complications inherent in the valuation of controllable assets.
- Item 11* Analyze changes in gross profit.
- Item 12* Define and compute a volume variance, a sales price variance, and a cost variance for single- and multiple-product firms.
- Item 13* Explain the role of gross profit variance analysis in the management control process.

All organizations, regardless of nature, size, or internal operating structure, are vitally concerned with performance measurement. In a profit-making enterprise, owners and creditors measure management's performance through the use of financial statement ratios such as earnings per share, dividends per share, return on assets, return on stockholders' equity,

coverage ratios, and debt ratio.¹ In a governmental agency (or program), the efficiency and the effectiveness in utilizing the resources appropriated by Congress are measured by either the General Accounting Office or the agency's (or program's) internal audit staff. It should be noted, however, that performance measurement in the public sector is far more difficult to accomplish than performance measurement in the private sector because of the numerous nonquantifiable factors associated with education, health care, defense, and so forth.

In most organizations, particularly large decentralized industrial companies, it is necessary to develop a sound basis for measuring the performance of all the company's cost, profit, and investment centers, since they are collectively responsible for the overall performance of the company as a whole. This chapter is concerned with the problems involved in establishing and administering an effective program of responsibility center performance measurement. In the appendix to this chapter and in the next chapter we expand the coverage of performance measurement to include gross profit analysis and transfer pricing, respectively. The common thread linking this chapter, the appendix, and the next chapter is their close relationship to, and dependence on, concepts of decentralization, principal–agency theory, and responsibility accounting explained in the previous chapter.

BASIS FOR COMPARISON

A responsibility center's operating results for the current period, in and of themselves, are inadequate for evaluating performance. As a general rule applicable to all three types of responsibility centers, only a comparative analysis can provide upper-level management with the information needed to evaluate the performance of a responsibility center and the performance of middle- and lower-level managers.

Three bases of comparison have been commonly used in practice by companies as a means of judging the “quality” of current period performance:

1. The operating results for the prior period could be compared with the operating results for the current period to assess interperiod performance.
2. The operating results for the current period for one responsibility center could be compared with the operating results for the current period of another *comparable* responsibility center of the same company to assess intracompany performance.

¹ For a discussion of the analysis and interpretation of financial statements, see Chapter 9.

3. The operating results for the current period for one responsibility center could be compared with the operating results for the current period of another *comparable* responsibility center of a competitive company, provided the data is available, to assess intercompany performance.

None of these three bases of comparison provides an optimum solution for judging the quality of current period performance. As a viable alternative, the following simple and workable solution to the comparative analysis problem is recommended.

At the beginning of the period, responsibility center managers should participate in the preparation of pro forma reports delineating their *expected performance*, as demonstrated in the previous chapter. That is, a cost center manager will help prepare a flexible budget of his or her controllable costs; a profit center manager will help prepare a budgeted “controllable income” statement; and an investment center manager will help prepare budgeted return on investment or residual income with both based on a budgeted controllable income statement and a schedule of budgeted controllable assets.

At the end of the period, a three-step approach will be used by responsibility center managers in conjunction with upper-level management:

1. Middle- and lower-level managers will prepare post-hoc reports delineating their *actual performance*.
2.
 - a. Cost center managers will compare their budgeted controllable costs with their actual controllable costs and compute the variances.
 - b. Profit center managers will compare their budgeted controllable income statements with their actual controllable income statements and compute the variances.
 - c. Investment center managers will compare their budgeted return on investment or residual income with their actual return on investment or residual income and compute the variances.
3. Upper-level management will employ the variance investigative procedures to try to:
 - a. Identify the cause of the variances.
 - b. Determine the most cost-efficient method of correcting the variances.
 - c. Implement the optimal corrective measures.

We will use a hypothetical company, the Highland Manufacturing Company, with three responsibility centers, to illustrate the first two steps in the performance evaluation process. The three responsibility centers are the assembly department (cost center), the riding toys segment (profit center), and the consumer products division (investment center). Figure 12.1 is a product approach (see discussion in Chapter 11) organization chart to

help better visualize the responsibility accounting structure of the Highland Manufacturing Company.

COST CENTER PERFORMANCE EVALUATION

As defined in Chapter 11, a cost center is a segment of a decentralized organization that has been assigned (delegated) control over the incurrence of costs. Accordingly, cost center performance evaluation is based on a comparison of budgeted controllable costs with actual controllable costs (for the level of activity actually achieved).

Because of the influence of one variable on the evaluation of cost center performance, a great amount of care must be exercised in the determination of controllable costs. The reason is that controllable costs should not automatically include all costs identified with a cost center because it is possible that a portion of the costs may be incurred through the actions of other responsibility center managers.

To implement this variance analysis strategy, a flexible budget system should be used. At the beginning of the period, all costs controllable by the cost center manager should be estimated at various probable levels of activity including normal activity (all within the relevant range). This flexible

FIGURE 12.1 The Highland Manufacturing Company Product Approach Organization Chart

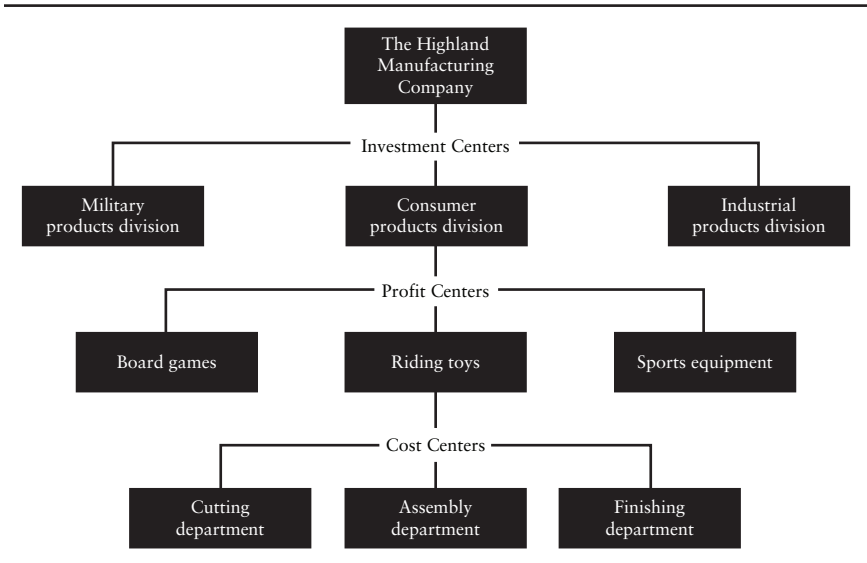

budget is fundamental to the initial planning of multiple cost center activities. It will also provide some measure of continuous guidance throughout the period in light of changing circumstances that would not be even remotely possible had a static budget been used.

At the end of the period actual controllable costs will be known at the actual level of activity achieved and they must be compared to flexible budgeted controllable costs at the same level of activity. Consequently, an *ex post* budget will have to be prepared. It may seem strange, at first glance, to prepare a budget at the end of the period when budgets are usually prepared at the beginning of the period. However, an end-of-the-period budget is obviously not used for planning purposes but, instead, exclusively for control purposes.

By way of an illustration, let us monitor the activities of the Assembly department of the Highland Manufacturing Company for the year 200X. Table 12.1 is a flexible budget prepared at the beginning of the year using the number of units assembled as the activity base that controls the incurrance of variable Assembly department controllable costs. (Production department flexible budgets will be discussed further in Chapter 24.) These flexible budgets were prepared for purposes of *product costing* and accord-

TABLE 12.1 The Highland Manufacturing Company (*Ex Ante*) Flexible Budget for Assembly Department Controllable Costs for 200X

| | Budget at 1,500 Units | Budget at 2,000 Units | Budget at 2,500 Units |
|---|--------------------------|--------------------------|--------------------------|
| <i>Controllable variable costs:</i> | | | |
| Indirect materials (\$2.00/unit) | \$3,000 | \$4,000 | \$5,000 |
| Indirect labor (\$3.00/unit) | 4,500 | 6,000 | 7,500 |
| Repairs (\$1.00/unit) | 1,500 | 2,000 | 2,500 |
| Power (\$1.50/unit) | <u>2,250</u> | <u>3,000</u> | <u>3,750</u> |
| Total controllable variable costs | <u>\$11,250</u> | <u>\$15,000</u> | <u>\$18,750</u> |
| <i>Controllable fixed costs:</i> | | | |
| Insurance | \$1,800 | \$1,800 | \$1,800 |
| Supervision (excluding the budgeted salary of the Assembly department manager) | 6,200 | 6,200 | 6,200 |
| Heat and light | 3,700 | 3,700 | 3,700 |
| Miscellaneous | <u>1,300</u> | <u>1,300</u> | <u>1,300</u> |
| Total controllable fixed costs | <u>\$13,000</u> | <u>\$13,000</u> | <u>\$13,000</u> |
| Total controllable costs | <u>\$24,250</u> | <u>\$28,000</u> | <u>\$31,750</u> |

ingly included both controllable as well as noncontrollable factory overhead costs in accordance with generally accepted accounting principles. The flexible budget prepared for purposes of cost center performance evaluation in Table 12.1 contains only those costs that are within the direct control of the Assembly department manager. Thus, Assembly department costs such as depreciation on factory equipment and factory rent have been deliberately omitted on the assumption that the decision to incur these significant costs would not be delegated to a cost center manager.

The actual variable and fixed Assembly department controllable costs as of the end of the period appear in Table 12.2. These end-of-the-period controllable costs were incurred in the assembly of 2,200 units; they cannot be meaningfully compared with any of the budgeted controllable costs that appear in Table 12.1's *ex ante* flexible budget because none of the activity levels contained therein (i.e., 1,500, 2,000, and 2,500 units) are comparable. It is necessary, therefore, to prepare an *ex post* budget of variable and fixed Assembly department controllable costs that should have been incurred in the assembly of 2,200 units if cost center performance is to be evaluated properly.

It is easy to prepare an *ex post* budget as shown in Table 12.3 because of the *cost behavior patterns* that are applicable to the Assembly depart-

TABLE 12.2 The Highland Manufacturing Company Schedule of Actual Controllable Costs of the Assembly Department for 200X

| | 2,200 Units Assembled |
|--|-----------------------|
| <i>Controllable variable costs:</i> | |
| Indirect materials | \$4,650 |
| Indirect labor | 6,700 |
| Repairs | 2,150 |
| Power | <u>3,600</u> |
| Total controllable variable costs | <u>\$17,100</u> |
| <i>Controllable fixed costs:</i> | |
| Insurance | \$1,800 |
| Supervision (excluding the actual salary of the Assembly department manager) | 6,200 |
| Heat and light | 3,740 |
| Miscellaneous | <u>1,460</u> |
| Total controllable fixed costs | <u>\$13,200</u> |
| Total controllable costs | <u>\$30,300</u> |

TABLE 12.3 The Highland Manufacturing Company (*Ex Post*) Budget of Assembly Department Controllable Costs for 200X

| | 2,200 Units Assembled |
|--|-----------------------|
| <i>Controllable variable costs:</i> | |
| Indirect materials (\$2.00/unit) | \$ 4,400 |
| Indirect labor (\$3.00/unit) | 6,600 |
| Repairs (\$1.00/unit) | 2,200 |
| Power (\$1.50/unit) | <u>3,300</u> |
| Total controllable variable costs | <u>\$16,500</u> |
| <i>Controllable fixed costs:</i> | |
| Insurance | \$ 1,800 |
| Supervision (excluding the budgeted salary of the Assembly department manager) | 6,200 |
| Heat and light | 3,700 |
| Miscellaneous | <u>1,300</u> |
| Total controllable fixed costs | <u>\$13,000</u> |
| Total controllable costs | <u>\$29,500</u> |

ment. That is, the variable controllable costs per unit for indirect materials, indirect labor, repairs, and power and the total controllable fixed costs for insurance, supervision, heat and light, and miscellaneous remain constant within the relevant range as the level of activity changes.

A cost center performance evaluation report appears in Table 12.4. It compares the controllable variable and fixed costs of the Assembly department that should have been incurred in the assembly of 2,200 units (Table 12.3) to the controllable variable and fixed costs of the Assembly department that were actually incurred in the assembly of 2,200 units (Table 12.2). Any differences constitute *deviations* (i.e., variances) from expected cost center performance and should be subjected to appropriate variance investigation procedures. As emphasized in the chapter on standard cost later in this book (Chapter 24), unfavorable variances do not necessarily imply that a cost center manager has performed at an unsatisfactory level. Only an investigation to identify the exact cause of the variance (assuming it to be successful) will reveal if anyone was responsible, and to what extent, for any disparity between budgeted cost center performance and actual cost center performance.

TABLE 12.4 The Highland Manufacturing Company Assembly Department Performance Evaluation Report for 200X

| | Budgeted Controllable Costs (2,200 Units) ^a | Actual Controllable Costs (2,200 Units) ^b | Unfavorable Variances (Favorable) |
|---|---|---|---|
| <i>Controllable variable costs:</i> | | | |
| Indirect materials | \$4,400 | \$4,650 | \$250 |
| Indirect labor | 6,600 | 6,700 | 100 |
| Repairs | 2,200 | 2,150 | (50) |
| Power | <u>3,300</u> | <u>3,600</u> | <u>300</u> |
| Total controllable variable costs | <u>\$16,500</u> | <u>\$17,100</u> | <u>\$600</u> |
| <i>Controllable fixed costs:</i> | | | |
| Insurance | \$ 1,800 | \$1,800 | \$0 |
| Supervision (excluding the budgeted and actual salary of the Assembly department manager) | 6,200 | 6,200 | 0 |
| Heat and light | 3,700 | 3,740 | 40 |
| Miscellaneous | <u>1,300</u> | <u>1,460</u> | <u>160</u> |
| Total controllable fixed costs | <u>\$13,000</u> | <u>\$13,200</u> | <u>\$200</u> |
| Total controllable costs | <u>\$29,500</u> | <u>\$30,300</u> | <u>\$800</u> |

^a See Table 12.3.

^b See Table 12.2.

Cost Center Decision Making

Why are performance evaluation and decision making about to be mixed? By illustrating cost center, profit center, and investment center decision making, two important pedagogical objectives will be accomplished. First, the concepts and techniques used, for example, in choosing between alternative courses of action will be reinforced. Second, it will be shown that the accounting group can generate data, if it is in the appropriate form, for both performance evaluation and decision-making purposes. That is, *controllable* items of revenue and expense used in performance evaluation may also possess the necessary characteristic of *relevance* for decision making. However, always remember that for decision-making purposes, the attribute of *relevancy* governs, whereas for performance evaluation purposes, the attribute of *controllability* governs. There is no reason per se, of course, why

selected items of revenue and expense cannot possess both attributes and thereby be used for both purposes.

Cost center decision making is restricted to the impact on total and per-unit controllable costs from alternative courses of action that management may contemplate pursuing. For example, suppose the XYZ Company has the budgeted controllable costs at 10,000 direct labor hours for the Finishing department shown in Table 12.5.

As you can see, total controllable costs are \$85,000 at a level of productive activity equal to 10,000 direct labor hours. If the \$85,000 is divided by the 10,000 direct labor hours, the total controllable costs equal \$8.50 per direct labor hour.

The Finishing department manager is considering two different plans, A and B, that promise to reduce controllable costs below \$85,000 at 10,000 direct labor hours. Plan A consists of the following three proposed changes in costs:

1. Increase the three variable costs per direct labor hour by \$0.05, \$0.08, and \$0.06, respectively.

TABLE 12.5 Finishing Department Flexible Budget at 10,000 Direct Labor Hours 200X

| Description | Variable Controllable Cost per Direct Labor Hour | Fixed Controllable Cost | Total Controllable Cost (at 10,000 Direct Labor Hours) |
|---|---|-------------------------------|---|
| <i>Variable controllable costs:</i> | | | |
| Supplies | \$1.50 | | \$15,000 |
| Indirect labor | 0.70 | | 7,000 |
| Receiving costs | 0.54 | | 5,400 |
| <i>Fixed controllable costs:</i> | | | |
| Rent | | \$5,500 | 5,500 |
| Property insurance | | 2,000 | 2,000 |
| Real estate taxes | | 450 | 450 |
| <i>Semivariable controllable costs:</i> | | | |
| Supervisors' salaries | 2.60 | 9,600 | 35,600 |
| Factory employees' insurance | 0.46 | 1,700 | 6,300 |
| Heat, light, and power | <u>0.70</u> | <u>750</u> | <u>7,750</u> |
| Total controllable costs | <u>\$6.50</u> | <u>\$20,000</u> | <u>\$85,000</u> |

2. Decrease the three fixed costs by \$2,500, \$900, and \$300, respectively.
3. Increase the variable component of the three semivariable costs per direct labor hour by \$0.05, \$0.16, and \$0.06, respectively, plus decrease the fixed component of the three semivariable costs by \$3,600, \$700, and \$150, respectively.

Plan B consists of the following three proposed changes in costs:

1. Decrease the three variable costs per direct labor hour by \$0.40, \$0.10, and \$0.14, respectively.
2. Increase the three fixed costs by \$2,700, \$1,500, and \$1,450, respectively.
3. Decrease the variable component of the three semivariable costs per direct labor hour by \$0.30, \$0.06, and \$0.10, respectively, plus increase the fixed component of the three semivariable costs by \$1,600, \$1,900, and \$450, respectively.

The manager of the Finishing department prepared the two evaluations shown in Table 12.6.

As expected by the manager of the Finishing department, both plan A (\$81,350) and plan B (\$83,600) represent desirable alternatives to the current amount of controllable costs at 10,000 direct labor hours (\$85,000). Clearly, plan A is better than plan B by \$2,250 (\$83,600 – \$81,350).

A careful inspection of both plans reveals that plan A consists of increasing variable costs per direct labor hour plus decreasing fixed costs. In direct contrast, plan B consists of decreasing variable costs per direct labor hour plus increasing fixed costs.

It may be of importance for the Finishing department manager, before making a final decision, to determine the *point of indifference* in the level of productive activity between the two plans. Although plan A is superior to plan B at 10,000 direct labor hours, management needs to know the *critical level* below which plan A continues to be superior to plan B and above which plan B reverses position and becomes superior to plan A. In the final analysis, the Finishing department manager will have to make a cost structure “alteration” decision (including the possibility of selecting neither plan A nor plan B) in light of the likelihood of operating above or below the point of indifference. Finding the all-important critical level consists of a simple algebraic solution:

Let X = number of direct labor hours at the point of indifference.

Plan A: $\$6.95X + \$11,850$

Plan B: $\$5.40X + \$29,600$

TABLE 12.6 Two Evaluation Plans, Plan A and Plan B, for the Finishing Department for 200X

| | Plan A | | | Plan B | | |
|--|------------------------|-------------|------------------------------------|------------------------|--------------|------------------------------------|
| | Variable Cost per Unit | Fixed Costs | Cost per 10,000 Direct Labor Hours | Variable cost per Unit | Fixed Costs | Cost per 10,000 Direct Labor Hours |
| <i>Variable controllable costs</i> | | | | | | |
| Supplies | \$1.55 | | \$15,500 | \$1.10 | | \$11,000 |
| Indirect labor | 0.78 | | 7,800 | 0.60 | | 6,000 |
| Receiving costs | 0.60 | | 6,000 | 0.40 | | 4,000 |
| <i>Fixed controllable costs</i> | | | | | | |
| Rent | | \$3,000 | 3,000 | | \$8,200 | 8,200 |
| Property insurance | | 1,100 | 1,100 | | 3,500 | 3,500 |
| Real estate taxes | | 150 | 150 | | 1,900 | 1,900 |
| <i>Semivariable controllable costs</i> | | | | | | |
| Supervisors' salaries | 2.65 | 6,000 | 32,500 | 2.30 | 11,200 | 34,200 |
| Factory employees' insurance | 0.62 | 1,000 | 1,000 | 0.40 | 3,600 | 7,600 |
| Heat, light, and power | <u>0.75</u> | <u>600</u> | <u>8,100</u> | <u>0.60</u> | <u>1,200</u> | <u>7,200</u> |
| Total | \$6.95 | \$11,850 | \$81,350 | \$5.40 | \$29,600 | \$83,600 |

As shown in Table 12.6, at 10,000 direct labor hours Plan A has a lower total cost than Plan B. But because Plan A and Plan B have different variable and fixed costs, whether one plan produces a lower total cost depends on the level of the direct labor hours. At what level of direct labor hours do the plans produce the same total cost? This level is the point of indifference.

To solve for the point of indifference in terms of the number of direct labor hours, equate the total cost of Plan A to the total cost of Plan B, as follows, and solve for X, the number of direct labor hours at which the two plans produce identical total costs:

$$\begin{aligned} \$6.95X + \$11,850 &= \$5.40X + \$29,600 \\ X &= 11,452 \text{ direct labor hours} \end{aligned}$$

With the additional knowledge of the point of indifference (11,452 direct labor hours), the manager of the Finishing department can now make a rational choice between plan A and plan B depending on his projected level of productive activity in relation to the critical level. If his productive activity is forecasted to be below 11,452 direct labor hours, plan A with its higher variable costs per direct labor hour but lower total fixed costs is best. However, if his productive activity is forecasted to be above 11,452 direct labor hours, plan B with its higher total fixed costs but lower variable costs per direct labor hour is better.

There are many other types of decisions that confront cost center managers as part of their routine planning. They can be dealt with in a manner similar to what has just been illustrated. The cost center manager must have an understanding of the underlying concepts of cost behavior, relevant costing, and the mechanics of the various techniques that are based thereon.

PROFIT CENTER PERFORMANCE EVALUATION

As defined in the previous chapter, a profit center is a segment of a decentralized organization that has been assigned (delegated) control over both the generation of revenues and the incurrence of costs. Accordingly, profit center performance evaluation should be based on a comparison of a budgeted controllable income statement with an actual controllable income statement (for the level of activity actually achieved).²

The performance of a cost center manager is evaluated on the basis of controllable cost. Controllable cost would be insufficient, however, as the

² A description of the flexible budget system used by a profit center would be unnecessarily repetitious in that it exactly parallels the flexible budget system used by a cost center described earlier.

basis for evaluating the performance of a profit center manager because of the additional element of revenues. As a consequence, the performance of a profit center manager is evaluated on the basis of controllable income, which is computed by deducting the profit center's controllable costs from the profit center's controllable revenues.

Because of the influence of two variables on the evaluation of profit center performance, a greater amount of care must be exercised (relative to the evaluation of cost center performance) in the preparation of a controllable income statement: First, controllable revenues should not automatically include all revenues identified with a profit center if a portion of the revenues were generated through the efforts of other responsibility center managers. For example, advertising efforts by one profit center may inadvertently promote the sale of products made by other profit centers. When General Motors chooses to advertise the quality and reliability associated with the General Motors name, the Chevrolet, Pontiac, Buick, and Cadillac responsibility centers benefit. If the "advertising" profit center receives no credit for helping to sell the products of the other profit centers, there is little or no motivation for continuing the present advertising strategy. If the sale of the products of the other profit centers declines as a consequence of changing advertising policy, the company as a whole is penalized. In such instances, it seems reasonable to share some controllable revenue between the advertising profit center and the other profit centers whose products are being promoted.

Second, controllable costs, as already shown from experience with cost centers, should not automatically include all costs identified with a profit center if a portion of the costs were incurred through the actions of other responsibility center managers. On the basis of the same rationale as put forth with respect to controllable revenue, the controllable cost of advertising should also be shared by all the involved profit centers.

Clearly, this type of arrangement is complicated and illustrates that common sense exercised by the decision maker is necessary (and not a blind and strict adherence to a rigid definition of controllability vis-à-vis performance evaluation) if all profit centers are to receive equitable treatment with respect to applicable controllable revenues and/or controllable costs. The difficult issue of cost allocation will be discussed later in this chapter.

In order to fully comprehend the detailed format of a controllable income statement, the traditional income statement (Table 12.7) for the Highland Manufacturing Company prepared on a segmented basis for financial reporting purposes will be explained.

Assuming that the revenues have been correctly charged to the profit centers responsible for their generation, the traditional income statement is still of no value for performance evaluation purposes because it includes

TABLE 12.7 The Highland Manufacturing Company Conventional Income Statement for 200X

| | Board Games | Riding Toys | Sports Equipment | Total |
|----------------------------|------------------|------------------|------------------|------------------|
| Sales | \$100,000 | \$150,000 | \$200,000 | \$450,000 |
| Cost of goods sold | <u>60,000</u> | <u>90,000</u> | <u>100,000</u> | <u>250,000</u> |
| Gross profit | <u>\$ 40,000</u> | <u>\$ 60,000</u> | <u>\$100,000</u> | <u>\$200,000</u> |
| <i>Operating expenses:</i> | | | | |
| Selling | \$ 7,000 | \$ 8,000 | \$ 20,000 | \$ 35,000 |
| Administration | <u>3,000</u> | <u>7,000</u> | <u>20,000</u> | <u>30,000</u> |
| Total operating expenses | <u>\$ 10,000</u> | <u>\$ 15,000</u> | <u>\$ 40,000</u> | <u>\$ 65,000</u> |
| Income before income tax | \$ 30,000 | \$ 45,000 | \$ 60,000 | \$135,000 |
| Income tax (40% rate) | <u>12,000</u> | <u>18,000</u> | <u>24,000</u> | <u>54,000</u> |
| Net income | <u>\$ 18,000</u> | <u>\$ 27,000</u> | <u>\$ 36,000</u> | <u>\$ 81,000</u> |

costs that are not within the control of profit center managers. On the basis of the following information, the traditional income statement presented in Table 12.5 will now be converted into a controllable income statement:

- Cost of goods sold includes \$30,000 of fixed factory overhead costs that are controllable by the three profit center managers in the amounts of \$12,000, \$8,000, and \$10,000, respectively.
- Of the \$35,000 of total selling expenses, 75% are variable selling expenses and 25% are fixed selling expenses; both variable and fixed selling expenses are within the control of the three profit center managers.
- Total administration expenses of \$30,000 include \$10,000 of fixed costs that have been arbitrarily allocated to profit centers in proportion to sales; no portion of these fixed costs are assumed (in this exercise) to be within the control of any of the three profit center managers. The balance of \$20,000 represents variable administration costs; these variable costs have been correctly charged to the profit centers responsible for their incurrence.

Table 12.8 may be thought of as a worksheet to determine the variable and fixed selling expenses that are controllable by the managers of board games, riding toys, and sports equipment. Table 12.9 may also be thought of as a worksheet to determine the fixed administration expenses that have been arbitrarily allocated to profit centers in proportion to sales and the

TABLE 12.8 Worksheet to Determine Each Profit Center’s Variable and Fixed Selling Expenses for 200X

| (1) | (2) | (3) | (4) | (5) | (6) |
|------------------|-----------------------|--|---|-------------------------------------|--|
| Profit Center | Total Selling Expense | Multiply Col. 2 by Variable Percentage | Controllable Amount of Variable Selling Expense [(2) × (3)] | Multiply Col. 2 by Fixed Percentage | Controllable Amount of Fixed Selling Expense [(2) × (5)] |
| Board games | \$ 7,000 | 75% | \$ 5,250 | 25% | \$1,750 |
| Riding toys | 8,000 | 75% | 6,000 | 25% | 2,000 |
| Sports equipment | <u>20,000</u> | 75% | <u>15,000</u> | 25% | <u>5,000</u> |
| | \$35,000 | | \$26,250 | | \$8,750 |

fixed administration expenses that are controllable by the managers of the three profit centers.

Table 12.7’s conventional income statement can now be converted into a controllable income statement based, in part, on the selling expense worksheet (Table 12.8) and the administration expense worksheet (Table 12.9). Despite its detailed format, Table 12.10’s controllable income statement is based on the following simple model:

$$\text{Controllable revenues} - \text{Controllable costs} = \text{Controllable income}$$

Now we are ready to use a controllable income statement to evaluate the performance of profit centers. Assume that Table 12.11’s controllable income statement for the riding toys segment of the Highland Manufacturing Company represents the end-of-the-period actual operating results for the production and sale of 10,000 units. Assume further that Table 12.11’s beginning-of-the-period flexible budget has as its middle column, merely by coincidence, of course, an *ex ante* controllable income statement for the production and sale of exactly 10,000 units such that the preparation of an *ex post* controllable income statement at the actual level of activity achieved will not be necessary. Table 12.12 is a profit center performance evaluation report comparing the controllable revenues and controllable costs of the riding toys segment that should have been incurred in the production and sale of 10,000 units (Table 12.11) with the controllable revenues and controllable costs that were actually incurred in the production and sale of 10,000 units (Table 12.10). The variances between expected and actual profit center performance should be subjected to the same investigative procedures as outlined earlier with respect to cost centers.

TABLE 12.9 Worksheet to Determine Each Profit Center's Variable Administration Expense for 200X

| (1) | (2) | (3) | (4) | (5) | (6) | (7) |
|------------------|-----------|---------------------------|------------------------------------|--|------------------------------|--|
| Profit Center | Sales | Percentage of Total Sales | Total Fixed Administration Expense | Allocation of Fixed Administration Expense [(3) × (4)] | Total Administration Expense | Controllable Amount of Variable Administration Expense [(6) – (5)] |
| Board games | \$100,000 | 22% ^a | \$10,000 | \$2,200 | \$3,000 | \$800 |
| Riding toys | 150,000 | 33 ^b | 10,000 | 3,300 | 7,000 | 3,700 |
| Sports equipment | 200,000 | 45 ^c | 10,000 | 4,500 | 20,000 | 15,500 |
| | \$450,000 | 100% | | \$10,000 | \$30,000 | \$20,000 |

Computations

- ^a Board games (\$100,000/\$450,000) = 22%
- ^b Riding toys (\$150,000/\$450,000) = 33
- ^c Sports equip. (\$200,000/\$450,000) = 45
100%

TABLE 12.10 The Highland Manufacturing Company Controllable Income Statement for 200X

| | Board Games | Riding Toys | Sports Equipment | Total |
|-----------------------------------|-----------------|-----------------|------------------|------------------|
| Sales | \$100,000 | \$150,000 | \$200,000 | \$450,000 |
| Variable cost of goods sold | <u>48,000</u> | <u>82,000</u> | <u>90,000</u> | <u>220,000</u> |
| Manufacturing contribution margin | <u>\$52,000</u> | <u>\$68,000</u> | <u>\$110,000</u> | <u>\$230,000</u> |
| Variable operating expenses: | | | | |
| Selling (Table 12.8) | \$5,250 | \$6,000 | \$15,000 | \$26,250 |
| Administration (Table 12.9) | <u>800</u> | <u>3,700</u> | <u>15,500</u> | <u>20,000</u> |
| Total variable operating expenses | <u>\$6,050</u> | <u>\$9,700</u> | <u>\$30,500</u> | <u>\$46,250</u> |
| Contribution margin | <u>\$45,950</u> | <u>\$58,300</u> | <u>\$79,500</u> | <u>\$183,750</u> |
| Controllable fixed expenses: | | | | |
| Fixed factory overhead | \$12,000 | \$8,000 | \$10,000 | \$30,000 |
| Selling (Table 12.8) | <u>1,750</u> | <u>2,000</u> | <u>5,000</u> | <u>8,750</u> |
| Total controllable fixed expenses | <u>\$13,750</u> | <u>\$10,000</u> | <u>\$15,000</u> | <u>\$38,750</u> |
| Profit center controllable income | <u>\$32,200</u> | <u>\$48,300</u> | <u>\$64,500</u> | \$145,000 |
| Uncontrollable fixed expenses: | | | | |
| Administration (Table 12.9) | | | | <u>10,000</u> |
| Income before income tax | | | | \$135,000 |
| Income tax (40% rate) | | | | <u>54,000</u> |
| Net income | | | | <u>\$81,000</u> |

| Computations | | | | | |
|---------------|--------------------|---|------------------------|---|-----------------------------|
| Profit Center | Cost of Goods Sold | - | Fixed Factory Overhead | = | Variable Cost of Goods Sold |
| Board games | \$60,000 | | \$12,000 | | \$48,000 |
| Riding toys | 90,000 | | 8,000 | | 82,000 |
| Sports equip. | <u>100,000</u> | | <u>10,000</u> | | <u>90,000</u> |
| | <u>\$250,000</u> | | <u>\$30,000</u> | | <u>\$220,000</u> |

Note: This statement is called here a “controllable income” statement. There are a number of frequently used alternative terms that you should be aware of; they consist, in part, of the following:

- “Controllable income” statement may be called: (a) divisional income statement, (b) contribution income statement, (c) contribution margin income statement, and (d) segment income statement.
- Controllable fixed expenses may be called: (a) directly traceable fixed expenses, (b) discretionary fixed expenses.
- Uncontrollable fixed expenses may be called: (a) unallocated fixed expenses, (b) common fixed expenses, (c) committed fixed expenses.

TABLE 12.11 The Highland Manufacturing Company (*Ex Ante*) Flexible Budget of Riding Toys Segment Controllable Income for 200X

| | Budget at 5,000 Units | Budget at 10,000 Units | Budget at 15,000 Units |
|---|--------------------------|---------------------------|---------------------------|
| Sales (\$15.20/unit) | \$76,000 | \$152,000 | \$228,000 |
| Variable cost of goods sold (\$8.00/unit) | <u>40,000</u> | <u>80,000</u> | <u>120,000</u> |
| Manufacturing contribution margin | \$36,000 | \$72,000 | \$108,000 |
| <i>Variable operating expenses:</i> | | | |
| Selling (\$0.56/unit) | \$2,800 | \$5,600 | \$8,400 |
| Administration (\$0.33/unit) | <u>1,650</u> | <u>3,300</u> | <u>4,950</u> |
| Total variable operating expenses | <u>\$4,450</u> | <u>\$8,900</u> | <u>\$13,350</u> |
| Contribution margin | \$31,550 | \$63,100 | \$94,650 |
| <i>Controllable fixed expenses:</i> | | | |
| Fixed factory overhead | \$8,150 | \$8,150 | \$8,150 |
| Selling | <u>1,950</u> | <u>1,950</u> | <u>1,950</u> |
| Total controllable fixed expenses | <u>\$10,100</u> | <u>\$10,100</u> | <u>\$10,100</u> |
| Profit center controllable income | <u>\$24,450</u> | <u>\$53,000</u> | <u>\$84,550</u> |

TABLE 12.12 The Highland Manufacturing Company Riding Toys Segment Performance Evaluation Report for 200X

| | Budgeted Controllable Income | Actual Controllable Income | Unfavorable Variances (Favorable) |
|-------------------------------------|------------------------------------|----------------------------------|---|
| Sales | \$152,000 | \$150,000 | \$2,000 |
| Variable cost of goods sold | <u>80,000</u> | <u>82,000</u> | <u>2,000</u> |
| Manufacturing contribution margin | \$72,000 | \$68,000 | \$4,000 |
| <i>Variable operating expenses:</i> | | | |
| Selling | \$5,600 | \$6,000 | \$400 |
| Administration | <u>3,300</u> | <u>3,700</u> | <u>400</u> |
| Total variable operating expenses | <u>\$8,900</u> | <u>\$9,700</u> | <u>\$800</u> |
| Contribution margin | <u>\$63,100</u> | <u>\$58,300</u> | <u>\$4,800</u> |
| <i>Controllable fixed expenses:</i> | | | |
| Fixed factory overhead | \$8,150 | \$8,000 | \$(150) |
| Selling | <u>1,950</u> | <u>2,000</u> | <u>50</u> |
| Total controllable fixed expenses | <u>\$10,100</u> | <u>\$10,000</u> | <u>\$(100)</u> |
| Profit center controllable income | \$53,000 | \$48,300 | \$4,700 |

Cost Allocation

Should a company *allocate* some or all of its general and administrative costs to profit centers? Many companies do so in the mistaken belief that profit center managers, alerted to the existence and amount of these common costs, will be collectively motivated to achieve a greater-than-projected amount of controllable income to more than offset general and administrative costs. If anything, the allocation of common costs may be counterproductive. Holding profit center managers responsible in their performance evaluation reports for large amounts of common costs beyond their control, would reduce the amount of their reported controllable income, the amount of their calculated executive incentive compensation (as discussed in Chapter 11), and consequently the desired stimulus to perform at or above expected levels.

The only viable exception would be for *incremental* amounts of common costs that can be *directly traced* to profit center activities. Since a cost allocation, therefore, would not be necessary, the profit center would be charged only for those common costs that were incurred (admittedly by the actions of upper-level management) theoretically in place of specific general and administrative costs that the profit center would have had to incur anyway in order to perform its everyday operations.

Other than the possible exception for incremental common costs, an allocation of general and administrative costs is (1) arbitrary at best (i.e., no cause-and-effect relationship exists between the amount of a company's common costs and the level of profit center activity) and (2) unfair at worst, as the following problem illustrates.

The XYZ Company, at the beginning of the year, allocated its estimated common costs as shown below on the basis of estimated controllable revenues.

| Profit Center | Estimated Controllable Revenue | Percent | Estimated Common Cost | Allocated Estimated Common Cost |
|---------------|--------------------------------|-----------|-----------------------|---------------------------------|
| A | \$4,000,000 | 40% | \$700,000 | \$280,000 |
| B | 2,500,000 | 25 | 700,000 | 175,000 |
| C | <u>3,500,000</u> | <u>35</u> | 700,000 | <u>245,000</u> |
| | \$10,000,000 | 100% | | \$700,000 |

Actual controllable revenues for profit centers B and C equaled estimated amounts, and actual common costs also equaled estimated common costs. However, for profit center A, the actual controllable revenues were 50% of their anticipated level. The XYZ Company, at the end of the year, would allocate its actual common costs as follows:

| Profit Center | Actual Controllable Revenue | Percent | Actual Common Cost | Allocated Actual Common Cost |
|---------------|-----------------------------|------------|--------------------|------------------------------|
| A | \$2,000,000 ^a | 25% | \$700,000 | \$175,000 |
| B | 2,500,000 | 31¼ | 700,000 | 218,750 |
| C | <u>3,500,000</u> | <u>43¾</u> | 700,000 | <u>306,250</u> |
| | \$8,000,000 | 100% | | \$700,000 |

^a \$4,000,000 × 50% = \$2,000,000

The managers of profit centers B and C would not be satisfied with this result and rightly so. Their actual controllable revenues were equal to their estimated controllable revenues with the actual common costs equal to the estimated common costs. Thus, both managers expect to receive an allocation of company general and administrative costs of \$175,000 and \$245,000, respectively. Instead, profit center B's allocation increased to \$218,750 and profit center C's allocation increased to \$306,250 despite the fact that their actual controllable revenues were right on target.

What could have caused this absurd result? The answer is simple and painfully obvious. The allocation scheme used by the company penalized profit centers B and C because of the failure of profit center A to achieve its estimated controllable revenues. The purpose and benefits of performance evaluation are adversely affected by the use of a tainted system of allocating company general and administrative costs to profit centers. That is, the performance of profit centers B and C was compromised by events beyond the control of their managers (i.e., the less-than-expected performance of profit center A).

PROFIT CENTER DECISION MAKING

The format and underlying concepts of a controllable income statement for performance evaluation purposes are based on the principles of cost behavior and relevant costing. As such, it is ideal for purposes of segment-oriented decision making. For example, consider Table 12.10's controllable income statement for board games, riding toys, and sports equipment. Suppose that the Highland Manufacturing Company has decided to spend an additional \$10,000 of profit center advertising but is not sure which profit center should receive the funds. These estimates have been provided: (1) If the \$10,000 were spent on board games advertising, sales would increase \$28,000; (2) if the \$10,000 were spent on riding toys advertising, sales would increase

\$36,000; and (3) if the \$10,000 were spent on sports equipment advertising, sales would increase \$35,000.

The first step in the solution of this type of decision-making problem is to compute the *contribution margin ratio (CMR)*. The CMR equals the contribution margin divided by sales and appears as follows for each of the three profit centers:

$$\text{Board games:} \quad \text{CMR} = \frac{\$45,950}{\$100,000} = 45.95\%$$

$$\text{Riding toys:} \quad \text{CMR} = \frac{\$58,300}{\$150,000} = 38.87\%$$

$$\text{Sports equipment:} \quad \text{CMR} = \frac{\$79,500}{\$200,000} = 39.75\%$$

The second and final step is to compute the amount of increased contribution margin. The amount of increased contribution margin equals the increase in sales produced by the \$10,000 of advertising times the CMR for each of the three profit centers; it appears as follows:

$$\text{Board games:} \quad \$28,000 \times 45.95\% = \$12,866$$

$$\text{Riding toys:} \quad \$36,000 \times 38.87\% = \$13,993$$

$$\text{Sports equipment:} \quad \$35,000 \times 39.75\% = \$13,912$$

The \$10,000 of advertising should be spent on the riding toys profit center, whose contribution margin would increase by the largest amount—\$13,993.

Other similar types of segment-oriented decision-making problems can be readily solved by manipulating the information contained in a profit center's controllable income statement.

INVESTMENT CENTER PERFORMANCE EVALUATION

As defined in Chapter 11, an investment center is a segment of a decentralized organization that has been assigned (delegated) control over the generation of revenues, incurrence of costs, and the acquisition of investment center assets. Investment centers are sometimes viewed as special cases of profit centers. That is, the investment center manager has decision-making authority (and accountability) for the level of physical (i.e., short- and long-term) assets and financial (i.e., semitemporary working capital and semi-

permanent invested capital) assets employed in the investment center. Accordingly, investment center performance evaluation should be based on a comparison of budgeted return on investment or residual income with actual return on investment or residual income (for the level of activity actually achieved).³

The performance of a cost center manager is evaluated on the basis of the controllable costs. The performance of a profit center manager is evaluated on the basis of controllable income. Controllable income would be insufficient, however, as the basis for evaluating the performance of an investment center manager because of the additional element of investment center assets. As a consequence, the performance of an investment center manager is evaluated on the basis of either return on investment or residual income. Return on investment is computed by dividing the investment center's controllable income by the investment center's controllable assets. As a formula, return on investment (ROI) could be written as

$$\text{ROI} = \frac{\text{Controllable income}}{\text{Controllable assets}}$$

Residual income is computed by first multiplying the investment center's controllable assets by the company's required or minimum desired rate of return⁴ and then subtracting the product from the investment center's controllable income. As a formula, residual income (RI) could be written as

$$\text{RI} = \text{Controllable income} \\ - (\text{Controllable assets} \times \text{Company's required rate of return})$$

Because of the influence of three variables on the evaluation of investment center performance, the greatest amount of care must be exercised (relative to the evaluation of either cost or profit center performance) in the computation of either ROI or RI for three reasons:

1. Controllable revenues, as already known from the discussion of profit centers, should not automatically include all revenues identified with an investment center if a portion of the revenues were generated through the efforts of other responsibility center managers.

³ The flexible budget system used by an investment center exactly parallels the flexible budget system used by a cost center as described earlier.

⁴ A company's required minimum desired rate of return is usually equal to its weighted average cost of capital. Controllable assets times a company's required rate of return acts as if it were an *opportunity cost*.

2. Controllable costs, as already known from the discussion of cost centers, should not automatically include all costs indentified with an investment center if a portion of the costs were incurred through the actions of other responsibility center managers.
3. Controllable assets should not automatically include all assets identified with an investment center if a portion of the assets were acquired through the endeavors of other responsibility center managers. Decision makers must determine not only what constitutes the short- and long-term controllable assets of an investment center but also what basis should be used in the valuation of the short- and long-term controllable assets of an investment center.

A substantial number of factors must be considered in developing an effective performance measurement program. There is no one answer for all companies. Manufacturing companies will differ from finance companies, such as banks or insurance companies, and retail stores will differ from utilities. There will be differences even within the same industry. The method of performance measurement for a particular company will depend on company needs and management preference. The most common method of performance measurement is return on investment.

Return on Investment

In order that the maximum potential advantage be obtained from decentralization, it is essential that management systematically measure and control the performance of its separate investment centers. In many cases management is unduly concerned with dollar sales, dollar earnings, and profit margins. A far more meaningful measure of managerial effectiveness could be obtained by combining investment and earnings into a single ROI equation. Although the method does have some serious limitations, as discussed later, it also has many advantages over alternative methods that are not sophisticated enough to deal with controllable assets.

ROI is often used to make comparisons between competing short-run projects to determine which is the most favorable investment. Thus, ROI can be used as an effective planning technique as well as a control technique. The example of the Crowell Paper Bag Company later in the chapter will illustrate the application of ROI in short-term decision making. With respect to performance evaluation, the investment center manager would be expected to produce a return on the assets within his or her control in excess of the return that could be obtained from an alternative use of these controllable assets. An illustration of the use of ROI in evaluating the performance of an investment center follows:

TABLE 12.13 The Highland Manufacturing Company Consumer Products Division Performance Evaluation Report for 200X

| | Budgeted at 500,000 Units Produced and Sold | Actual at 500,000 Units Produced and Sold | Unfavorable (Favorable) Variances |
|----------------------|---|---|---|
| Controllable income | \$600,000 | \$555,500 | \$44,500 |
| Controllable assets | \$5,000,000 | \$5,050,000 | \$50,000 |
| Return on investment | 12% | 11% | 1% |

The consumer products division of the Highland Manufacturing Company forecasted at the beginning of the period that 500,000 units would be produced and sold (at \$20 per unit or \$10,000,000); its controllable income at that level of activity was estimated to be \$600,000 on the basis of controllable assets of \$5,000,000.⁵ At the end of the period, 500,000 units were actually produced and sold (as originally forecasted); actual controllable income was \$555,500 on the basis of actual controllable assets of \$5,050,000. Table 12.13 is an abbreviated investment center performance evaluation report comparing the ROI of the consumer products division that should have been realized to the ROI that was actually realized.

A 12% ROI was expected but only an 11% ROI was realized. An inspection of the data contained in Table 12.13 reveals that the decrease in ROI was due to two factors: (1) The actual amount of controllable income was \$44,500 less than the amount that should have been earned from the production and sale of 500,000 units, and (2) the actual amount of controllable assets was \$50,000 more than it should have been in order to support the production and sale of 500,000 units. These two unfavorable variances between expected and actual controllable income and controllable assets should be subjected to the same investigative procedures as outlined earlier with respect to cost centers.

Investment Turnover and Earnings Ratio (Margin)

A somewhat different approach may be used to compute return on investment as a means of providing more information as to the performance of an investment center. The expanded ROI formula is shown as the product of the following two distinct elements—*investment turnover* and the *earnings ratio*:

⁵ Estimated controllable income would be derived in exactly the same way in which it was derived for a profit center. As for estimated controllable assets, a schedule would have to be prepared listing all the short- and long-term assets within the control of the investment center manager at whatever valuation basis had been selected.

$$\text{ROI} = \text{Investment turnover} \times \text{Earnings ratio}$$

The investment turnover indicates management's efficiency in using assets at its disposal to generate revenues and is computed as follows:

$$\text{Investment turnover} = \frac{\text{Controllable revenues}}{\text{Controllable assets}}$$

The investment turnover is the percentage of revenues generated in relation to the amount of total assets employed. The higher the investment turnover the better, because this means that a larger percentage of sales is generated in relation to the amount invested. For example, assume sales of \$500,000 and an investment (total assets employed) of \$2,000,000. The investment turnover would be 25% ($\$500,000 \div \$2,000,000$). If \$600,000 in sales were generated, the investment turnover would increase to 30% ($\$600,000 \div \$2,000,000$). Note that the investment turnover does not give any indication of the amount of profit or loss from revenues, and therefore, a high investment turnover does not necessarily mean that an investment center will have high controllable income; in fact, a loss could result. Investment turnover is primarily used to compare a beginning-of-period projected investment turnover to an end-of-period actual investment turnover to determine how efficiently an investment center is using its controllable assets.

The earnings ratio shows the all-important revenue-cost-income relationship and is computed as follows:

$$\text{Earnings ratio} = \frac{\text{Controllable income}}{\text{Controllable revenues}}$$

The earnings ratio depicts the relationship of controllable income to controllable revenues by computing the percentage of profit in each dollar of sales. The earnings ratio can be favorably increased by increasing revenues and/or decreasing expenses. The higher the earnings ratio the better, because this indicates that a larger percentage of each sale is made up of income as compared to a return of cost. For example, revenues of \$500,000 that generated an income of \$100,000 would result in a 20% ($\$100,000 \div \$500,000$) earnings ratio. Therefore, 20% of sales represents income and 80% cost. If income were to increase to \$150,000, the earnings ratio would increase to 30% ($\$150,000 \div \$500,000$). Management would be interested in any change in the earnings ratio because it means that a shift has developed in the all-important revenue-cost-income relationship.

The expanded ROI formula encompassing the product of investment turnover and earnings ratio is stated as follows:

$$\text{ROI} = \frac{\text{Controllable revenues}}{\text{Controllable assets}} \times \frac{\text{Controllable income}}{\text{Controllable revenues}}$$

With the introduction of the investment turnover and the earnings ratio, Figure 12.2 provides a graphic presentation of the many factors that underlie the ROI formula. Each factor should be taken into consideration in a comparison of expected investment center performance versus actual investment center performance. The illustration in Table 12.14 is a comparison of budgeted investment turnover and earnings ratio to actual investment turnover and earnings ratio.

As shown in Table 12.13, the consumer products division of the Highland Manufacturing Company experienced a 1 percentage point (12% – 11%) falloff in its expected ROI because of an unfavorable \$44,500 decrease in controllable income and an unfavorable \$50,000 increase in controllable assets. A more comprehensive measure of the performance of an investment center is provided by the separate analysis of the investment turnover and the earnings ratio.

As for the investment turnover, there has been a slight improvement in the utilization of assets as evidenced by the actual investment turnover of 2.1 versus the budgeted investment turnover of 2. The favorable increase of \$605,000 in controllable revenues was responsible for the favorable increase in investment turnover.

As for the earnings ratio, there has been a significant decline in the amount of controllable income generated by each dollar of controllable revenue as evidenced by the actual earnings ratio of 5.24% versus the budgeted earnings ratio of 6%. The single most important insight that can be gleaned from this analysis of the earnings ratio is the apparent inability of the manager of the consumer products division to control costs properly; this caused controllable income to be lower than it should have been. With actual controllable revenues of \$10,605,000, the controllable income could have been a healthy \$636,300 (6% of \$10,605,000) had the budgeted earnings ratio of 6% been achieved (as it should have been). The next step, of course, would be the employment of variance investigation procedures, as outlined with respect to cost centers, in order to pinpoint which specific costs were responsible for the \$44,500 decrease in controllable income.

Investment center managers can use the expanded ROI formula with its investment turnover and earnings ratio as a planning technique. That is, alternative operating strategies can be explored along with their potential impact on ROI. It is clear, however, that ROI can be improved only by one or a combination of the following actions:

FIGURE 12.2 Factors Underlying the Return on Investment Formula

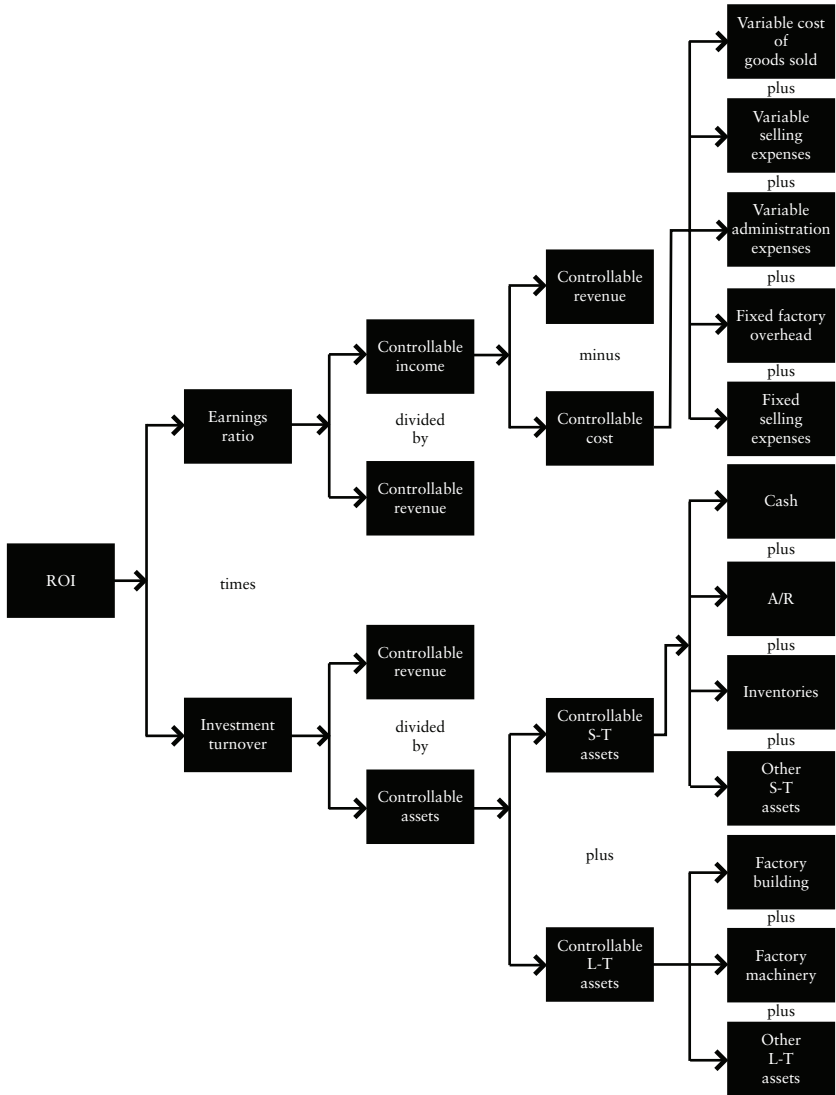

1. *Increasing controllable revenues* (e.g., by increasing either the selling price per unit or the number of units sold).
2. *Increasing controllable income* (e.g., decreasing controllable costs).
3. *Decreasing controllable assets* (e.g., by eliminating assets that fail to provide an investment center's minimum desired rate of return).

Strengths and Weaknesses of ROI

There are seven principal strengths of ROI in performance measurement:

1. It can act as a comprehensive measure, sensitive to every influence affecting the operating status of investment centers.
2. It can direct and simplify the efforts of investment center managers in maximizing controllable income relative to controllable assets.
3. It can serve as a basis for measuring investment center managers' performance in utilizing the resources within their control (via the investment turnover).
4. It can serve as a basis for measuring investment center managers' performance in controlling costs in relation to revenues (via the earnings ratio).

TABLE 12.14 The Highland Manufacturing Company Consumer Products Division Performance Evaluation Report for 200X

| | Investment Turnover | × | Earnings Ratio | = | ROI |
|---|------------------------------------|---|----------------------------------|---|------------------------|
| Budgeted ROI at 500,000 units produced and sold | $\frac{\$10,000,000}{\$5,000,000}$ | × | $\frac{\$600,000}{\$10,000,000}$ | = | 12% |
| | 2 | × | 6% | = | 12 |
| Actual ROI at 500,000 units produced and sold | $\frac{\$10,605,000}{\$5,050,000}$ | × | $\frac{\$555,500}{\$10,605,000}$ | = | 11 |
| | 2.1 | × | 5.24% | = | 11 |
| | Controllable Income | | Controllable Revenues | | Controllable Assets |
| Budgeted amount | \$600,000 | | \$10,000,000 | | \$5,000,000 |
| Actual amount | <u>555,500</u> | | <u>10,605,000</u> | | <u>5,050,000</u> |
| Unfavorable variances (favorable) | <u>\$44,500</u> | | <u>\$(605,000)</u> | | <u>\$50,000</u> |

5. It can provide an objective measure of investment center performance as budgeted at the beginning of the period and compared to actual end-of-the-period investment center performance.
6. It can help investment center managers explore alternative courses of action that might lead to the maximum possible improvement in their performance.
7. It can provide an incentive (possibly tied to a bonus plan) to use existing controllable assets to their fullest and to acquire only those additional resources that will increase ROI.

The five principal weaknesses of ROI in performance measurement are as follows:

1. It narrowly focuses on maximization in terms of a single ratio (controllable income to controllable assets) rather than on maximization of absolute controllable income dollars, which worked so well in the performance evaluation of profit center managers.
2. As is the case with any preestablished standard, the projected ROI at the beginning of the period may be set unrealistically high and could seriously discourage investment center incentive, or the projected ROI at the beginning of the period may be set unrealistically low, which could also adversely affect the performance of investment center managers.
3. It can easily cause the individual goals of investment center managers to conflict with the overall goals of the company, causing a lack of goal congruence in one of three ways:
 - a. Investment center managers may be reluctant to acquire additional assets whose ROI is higher than the company's overall ROI but lower than the investment center's ROI.
 - b. Investment center managers may acquire additional assets whose ROI is lower than the company's overall ROI but higher than the investment center's ROI.
 - c. Investment center managers may make short-run decisions that help to increase their ROI (such as intentionally decreasing needed discretionary expenditures on repair and maintenance of machinery) but such actions are not in the long-run best interests of the company.
4. It may oversimplify a highly complex process of investment center performance evaluation and decision making.
5. It presents difficulties associated with allocating assets.

In summary, the major problem with ROI as a performance evaluation technique, as alluded to in 3a and b, above, is the strong likelihood that it will lead to *dysfunctional decision making* by investment center managers

from the perspective of the company as a whole. The fault lies not with the investment center managers who are acting rationally in their own best interests but with the ROI technique that stresses maximizing an investment center's ratio of controllable income to controllable assets. Next we will provide two examples of a lack of goal congruence wherein (1) one investment center manager rejects a desirable project and (2) another investment center manager accepts an undesirable project.

Illustration of ROI and a Lack of Goal Congruence

The following results for 200X were reported by Case Company's two investment centers:

| | Investment Center 1 | Investment Center 2 |
|---------------------|---------------------|---------------------|
| Controllable income | \$200,000 | \$450,000 |
| Controllable assets | \$1,000,000 | \$3,000,000 |
| ROI | 20% | 15% |

The Case Company has a required rate of return equal to 12%. Upper-level management is considering an investment proposal that should earn \$90,000 of income on \$500,000 of assets. The investment proposal's ROI equals 18% ($\$90,000/\$500,000$). Upper-level management is in the process of choosing which of its two investment centers will be asked to initiate the investment proposal. As far as upper-level management is concerned, it is very excited about the project's anticipated 18% return, which is well in excess of the company's 12% required rate of return. Upper-level management would expect that both of its investment center managers would be equally excited. For investment center 1 and investment center 2, what course of action should their managers take if they were confronted by upper-level management's proposed investment?

The manager of investment center 1 would, to the surprise of upper-level management, *reject* the proposal on the basis of the following comparative analysis:

| | ROI Before Accepting Proposal | Investment Proposal | ROI After Accepting Proposal |
|---------------------|----------------------------------|------------------------|---------------------------------|
| Controllable income | \$200,000 | \$90,000 | \$290,000 |
| Controllable assets | \$1,000,000 | \$500,000 | \$1,500,000 |
| ROI | 20% | 18% | 19.33% |

It is perfectly rational for investment center 1's manager to reject an investment proposal that would reduce ROI from 20% to 19.33% despite

the fact that the investment proposal is desirable from the perspective of the company as a whole.

The manager of investment center 2 would, as expected by upper-level management, *accept* the proposal on the basis of the following comparative analysis:

| | ROI Before Accepting Proposal | Investment Proposal | ROI After Accepting Proposal |
|---------------------|----------------------------------|------------------------|---------------------------------|
| Controllable income | \$450,000 | \$90,000 | \$540,000 |
| Controllable assets | \$3,000,000 | \$500,000 | \$3,500,000 |
| ROI | 15% | 18% | 15.43% |

The manager of investment center 2 accepted the Case Company's proposal, not because he wanted to make a sacrifice for the benefit of the company as a whole, but only because it increased his ROI from 15% to 15.43%.

The intent of this illustration is to demonstrate that a lack of goal congruence can readily occur when ROI is used to evaluate the performance of investment center managers. Investment center 1 rejected a desirable project that would have, had it been accepted, been in the best interest of the company as a whole.

Next consider the following illustration. The Renck Company has a required rate of return equal to 10%. One of its investment centers, a foreign subsidiary located on the moon, has been doing very poorly and reported the following results in the year 200X:

| | |
|---------------------|-----------|
| Controllable income | \$4,000 |
| Controllable assets | \$100,000 |
| ROI | 4% |

The subsidiary is considering an unusual investment proposal to manufacture a product that should earn \$600 of income on \$10,000 of assets. The investment proposal's ROI equals 6% ($\$600/\$10,000$). As far as upper-level management is concerned, it is totally against the project because its anticipated 6% return is well below the company's 10% required rate of return. Upper-level management would expect that its investment center manager would be as disenchanted with the proposal as it is. For the investment center, what course of action would its manager take with respect to this investment project?

The manager of the investment center would, to the surprise of upper-level management, *accept* the proposal on the basis of the following comparative analysis:

| | ROI Before Accepting Proposal | Investment Proposal | ROI After Accepting Proposal |
|---------------------|----------------------------------|------------------------|---------------------------------|
| Controllable income | \$4,000 | \$600 | \$4,600 |
| Controllable assets | \$100,000 | \$10,000 | \$110,000 |
| ROI | 4% | 6% | 4.18% |

Once again, an investment center manager accepts a project only because it increases his ROI from 4% to 4.18%, despite the obvious fact that upper-level management would like nothing better than to see the project rejected.

The intent of this illustration is to demonstrate once again that a lack of goal congruence can readily occur when ROI is used to evaluate the performance of investment center managers. An investment center manager accepted an undesirable project that will not be in the best interest of the company as a whole.

Residual Income

The residual income concept was developed to overcome the principal shortcoming of ROI: that it focused on maximization of the *rate* of return rather than on absolute dollars. This important refinement of the ROI concept was developed by General Electric Company for the performance measurement of its own investment centers. Under this method, performance is measured by the *amount* of residual income rather than by a *rate* of return. The residual income of an investment center is equal to its controllable income minus an opportunity-type cost (i.e., controllable assets times the company's required rate of return).

Figure 12.3 provides a graphic presentation of the many factors that underlie the RI formula. In essence, upper-level management is literally charging an investment center for using those assets within its control that were, no doubt, paid for via company funds even though authorized by the investment center manager. By doing so, the company is implying that it can get, from an alternative use of investment center assets, a rate of return at least equal to its minimum desired rate of return.

Another possible interpretation for charging an investment center is as follows: By charging the investment center, the company is saying that the assets tied up in the investment center have a cost, just like all of the other costs controllable by the investment center manager. These costs are charged to the investment center on the basis of the company's required rate of return. Any income earned by an investment center in excess of this opportunity-type cost is beneficial both to the investment center and to the company. Hence, goal congruence will be achieved as an investment center manager strives to maximize residual income.

FIGURE 12.3 Concepts Underlying the Residual Income Formula

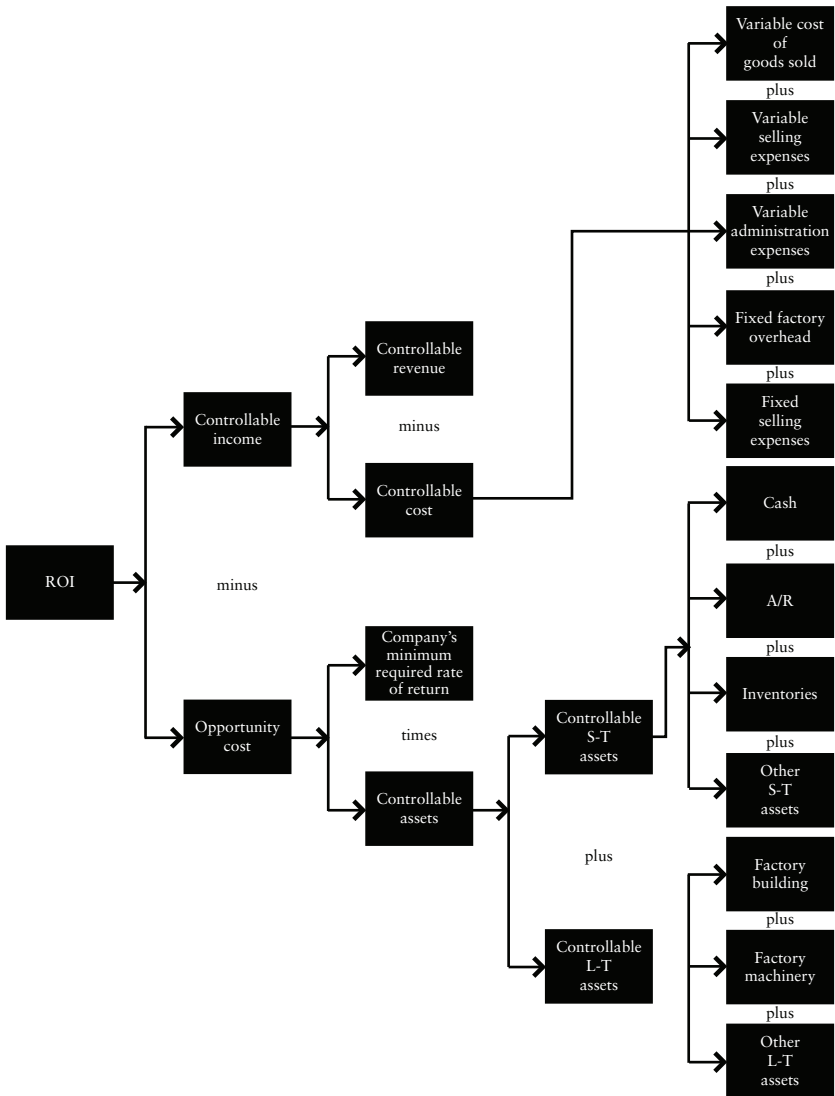

Let's use our two previous illustrations to show that the use of residual income in place of return on investment leads to better decision making wherein an investment center manager accepts a desirable project and rejects an undesirable project. For the investment centers of Case Company, the manager of investment center 1 would, as expected by upper-level management, *accept* the proposal on the basis of the following comparative analysis:

| | RI Before Accepting Proposal | Investment Proposal | RI After Accepting Proposal |
|---|------------------------------------|---------------------------|-----------------------------------|
| Controllable income | \$200,000 | \$90,000 | \$290,000 |
| Minimum desired rate of return × controllable assets | <u>120,000^a</u> | <u>60,000^b</u> | <u>180,000^c</u> |
| Residual income | \$ 80,000 | \$30,000 | \$110,000 |

Computations

^a $12\% \times \$1,000,000 = \$120,000$

^b $12\% \times \$500,000 = \$60,000$

^c $12\% \times \$1,500,000 = \$180,000$

The manager of investment center 1 would accept the Case Company's proposal because it increased RI from \$80,000 to \$110,000. This course of action is in the best interest of the company as a whole, so that goal congruence would be achieved. Recall that when ROI was used in this same situation, it would result in a rejection of the proposal by investment center 1's manager and, therefore, a lack of goal congruence.

The manager of investment center 2 would also, as expected by upper-level management, *accept* the proposal on the basis of the following comparative analysis:

| | RI Before Accepting Proposal | Investment Proposal | RI After Accepting Proposal |
|---|------------------------------------|---------------------------|-----------------------------------|
| Controllable income | \$450,000 | \$90,000 | \$540,000 |
| Minimum desired rate of return × controllable assets | <u>360,000^a</u> | <u>60,000^b</u> | <u>420,000^c</u> |
| Residual income | \$ 90,000 | \$30,000 | \$120,000 |

Computations

^a $12\% \times \$3,000,000 = \$360,000$

^b $12\% \times \$500,000 = \$60,000$

^c $12\% \times \$3,500,000 = \$420,000$

The manager of investment center 2 would accept the Case Company’s proposal because it increased RI from \$90,000 to \$120,000. This course of action is in the best interest of the company as a whole such that goal congruence would be achieved.

The manager of Renck’s investment center would, much to the relief of upper-level management, *reject* the proposal on the basis of the following comparative analysis:

| | RI Before Accepting Proposal | Investment Proposal | RI After Accepting Proposal |
|---|------------------------------------|--------------------------|-----------------------------------|
| Controllable income | \$4,000 | \$600 | \$4,600 |
| Minimum desired rate of return × controllable assets | <u>10,000^a</u> | <u>1,000^b</u> | <u>11,000^c</u> |
| Residual income | \$(6,000) | \$(400) | \$(6,400) |

Computations

^a 10% × \$100,000 = \$10,000

^b 10% × \$10,000 = \$1,000

^c 10% × \$110,000 = \$11,000

The manager of the investment center would reject the proposal because it decreased his RI from a negative \$6,000 to a negative \$6,400. This course of action is in the best interests of the company as a whole so that goal congruence would be achieved. Recall that when ROI was used in this same situation, it resulted in an acceptance of the proposal by the investment center’s management and, therefore, a lack of goal congruence.

While the subject of dysfunctional decision making is being discussed, a limited number of other controllable cost-related problems that may result from the use of quantitative measures of responsibility center profitability should be identified. These are (1) insufficient discretionary expenditures for advertising, R & D, R & M, employee training and advancement, customer services, and so on, (2) cost cutting at the potential expense of maintaining quality, and (3) the excessive use of *slack* in budgeting performance.

Many companies have developed nonfinancial measures to provide a more balanced evaluation of responsibility center performance. Some of the more important examples include:

1. Productivity ratios such as output per unit of scarce resource.
2. Market share by product line, geographical location (domestic and/or foreign), wholesale versus retail, or consumer versus industrial versus military.

3. Employee morale.
4. Employee retention and promotability.
5. Customer relations.
6. Company image and product recognition.
7. Technological innovations and new product development.
8. Good citizenship (i.e., compliance with environmental and other regulations, minority hiring, charitable and community service, etc.).

This list of eight possible nonprofit measures of performance is by no means exhaustive. It shows, however, that a responsibility center manager will be held accountable for multidimensional targeted company objectives. A responsibility center manager would be evaluated on whether any or all of these budgeted goals were actually achieved.

It is important to realize that a single and simplistic measure of performance for cost centers, profit centers, and investment centers has been discussed in this chapter. In practice, CFOs will have to deal with complex issues that call for tailoring a system to fit the performance evaluation needs of a company.

Table 12.15 is an example of the use of residual income in performance evaluation for the consumer products division of the Highland Manufacturing Company, which has a minimum desired rate of return equal to 10%. As already shown in Tables 12.13 and 12.14, the consumer products division of the Highland Manufacturing Company experienced an unfavorable \$44,500 decrease in controllable income and an unfavorable \$50,000 increase in controllable assets. With a 10% desired rate of return, the consumer products division is being charged an additional \$5,000 of opportunity-type cost causing its residual income to be \$49,500 less than it should have been. As in the case of cost centers, profit centers, and investment centers that use ROI instead of RI, a variance investigation should be employed to determine which elements of operating performance were responsible for the failure of the consumer products division to earn a satisfactory amount of RI at least equal to or better than the \$100,000 of budgeted RI.

Valuation and Allocation of Controllable Assets

In using ROI or RI for purposes of investment center performance evaluation, certain potential complications arise in determining the valuation of controllable assets. For example, materials inventory, work-in-process inventory, and finished goods inventory may be subject to imaginary valuation problems. A comparative analysis may be supposedly distorted if some of the inventory is valued at FIFO, some at weighted average, and some at LIFO. As for noncurrent assets such as factory building, factory machinery, and other long-term depreciable assets, they will be valued, in general, according to one of the three following methods: original cost, net book value, or replacement cost.

TABLE 12.15 The Highland Manufacturing Company Consumer Products Division Performance Evaluation Report for 200X Based on Residual Income

| | Budgeted at 500,000 Units Produced and Sold | Actual at 500,000 Units Produced and Sold | Unfavorable Variances (Favorable) |
|---|---|---|---|
| Controllable income | \$600,000 | \$555,500 | \$44,500 |
| Controllable assets | \$5,000,000 | \$5,050,000 | \$50,000 |
| Minimum desired rate of return (opportunity-type cost) | x 10% | x 10% | x 10% |
| Residual income | 500,000 | 505,000 | 5,000 |
| | \$100,000 | \$ 50,500 | \$49,500 |

Proponents of valuation at original cost point out that comparisons of long-term depreciable assets can be more reasonably made because of the many different methods of depreciation that are currently in use within a company. Proponents of net book value argue that original cost overstates long-term asset values and fails to give recognition to the consumption of long-term assets over time through cumulative reductions to original cost (i.e., accumulated depreciation). Proponents of valuation at replacement cost assert that current (realistic) values should be used rather than outdated original costs or understated net book values (on the basis of periodic depreciation of original cost). The net book value of factory building, factory machinery, and other long-term depreciable assets on the basis of replacement cost has the most theoretical appeal in that it combines the best features of asset consumption (as reflected in net book value) and current values (as reflected in replacement cost).

In the final analysis, however, it makes very little difference as to which basis of controllable asset valuation is used for inventories or long-term depreciable assets so long as the basis selected is applied consistently. That is, whatever basis is used in the beginning-of-the-period determination of budgeted ROI or RI should also be used in the end-of-the-period determination of actual ROI or RI.

Another potential problem involves the physical location (in an accounting sense) of certain current assets that are vulnerable to misuse. In most companies, as part of a system of internal control, cash, accounts receivable, and other short-term assets are maintained under the control of central management. A question immediately arises in ROI and RI computations for purposes of performance evaluation whether these current assets should be allocated to investment centers and, therefore, should be included in "controllable assets." The authors believe the answer is obvious and need not be based on a literal interpretation of the criterion that determines controllability wherein a specified investment center manager has to be identified as the sole person responsible for the decision to acquire the asset. Instead, if cash, accounts receivable, and other short-term assets are a natural outcome of the productive activity of an investment center regardless of their location within the organization for purposes of physical control, their dollar amounts should be "allocated" to investment centers when computing ROI or RI. See the discussion of cost allocation earlier in the chapter.

Investment Center Decision Making

It has been shown that cost center managers make decisions that affect their controllable costs and profit center managers make decisions that affect their controllable income. Investment center managers, obviously, make

decisions that affect their return on investment or residual income. The illustration to follow will show how an investment center manager might determine short-term selling price in light of, first, a target ROI and, second, a target RI. It should be understood, however, that investment center decision making is usually long-term in nature. As a consequence, an investment center manager would, of necessity, apply the time value of money concept via the use of the capital budgeting techniques discussed in Chapters 14, 15, and 16. The illustration here of investment center decision making has been included to show the potential impact of the two performance evaluation techniques—ROI and RI—on the resolution of only short-run-type problems (e.g., selling price decisions).

The Crowell Paper Bag Company's most important investment center—supermarket paper bags—earned a return on investment of 12% on the basis of the production and sale of 2 million units last period. Controllable income and controllable revenues were \$120,000 and \$480,000, respectively.

The manager of supermarket paper bags is considering increasing controllable assets by 20% this period in order to produce and sell 500,000 units of a newly invented product—paper laundry bags. The earnings ratio, despite the switch in products, is not expected to change.

The policy of Crowell Paper Bag Company is to insist on a minimum ROI of 15% on new products (because of the risks and uncertainties inherent in the introduction of any new product). On the basis of actual data from last period and projected data for this period, it is necessary to determine the exact selling price per paper laundry bag that must be charged in order to earn an ROI equal to 15%.

In order to find the minimum selling price per paper laundry bag, wherein ROI is used to evaluate performance, the following series of computations have to be made.

First, the old amount of controllable assets has to be calculated:

$$\begin{aligned} \text{ROI} &= \frac{\text{Controllable income}}{\text{Controllable assets}} \\ 12\% &= \frac{\$120,000}{\text{Controllable assets}} \\ \text{Controllable assets} &= \frac{\$120,000}{12\%} = \$1,000,000 \end{aligned}$$

Second, the increased amount of controllable assets has to be determined:

$$\$1,000,000 \times 120\% = \$1,200,000$$

Third, the new amount of controllable income has to be forecasted using the increased amount of controllable assets and the 15% required ROI:

$$15\% = \frac{\text{Controllable income}}{\$1,200,000}$$

$$\text{Controllable income} = (15\%)(\$1,200,000) = \$180,000$$

Fourth, the unchanging earnings ratio has to be computed:

$$\begin{aligned} \text{Earnings ratio} &= \frac{\text{Controllable income}}{\text{Controllable revenues}} \\ &= \frac{\$120,000}{\$480,000} = 25\% \end{aligned}$$

Fifth, the new amount of controllable revenues has to be forecasted (using the earnings ratio formula):

$$\begin{aligned} 25\% &= \frac{\$180,000}{\text{Controllable revenues}} \\ \text{Controllable revenues} &= \frac{\$180,000}{25\%} = \$720,000 \end{aligned}$$

Finally, the minimum selling price is found as follows:

$$\begin{aligned} \text{Selling price} &= \frac{\text{Forecasted revenues}}{\text{Forecasted units to be sold}} \\ &= \frac{\$720,000}{500,000 \text{ units}} \\ &= \$1.44 \text{ per paper laundry bag} \end{aligned}$$

There may be some unwarranted doubts about investment center decision making in the specific context of residual income. All the original facts and computations can be used plus only two additional facts: (1) The supermarket paper bags division insists on a 120% increase in its residual income before introducing any new product to compensate for risk and (2) the company's minimum desired rate of return is equal to 10%.

In order to find the minimum selling price per paper laundry bag where RI is used to evaluate performance, the following series of computations have to be made.

First, the old amount of RI has to be calculated:

| | |
|---|-----------------|
| Controllable income | \$120,000 |
| Less controllable assets times company's minimum desired rate of return (10% × \$1,000,000) | <u>100,000</u> |
| Residual income | <u>\$20,000</u> |

Second, the increased amount of RI has to be computed:

| | |
|---|---------------|
| Residual income | \$20,000 |
| Increased (100% existing + 120% increase) | × <u>220%</u> |
| Desired residual income | \$44,000 |

Third, the new amount of controllable income has to be forecasted using the RI but working backward:

| | |
|--|----------------|
| Desired residual income | \$44,000 |
| Plus: Controllable assets times company's minimum desired rate of return (10% × \$1,200,000 ^a) | <u>120,000</u> |
| Controllable income | \$164,000 |

^a The \$1,200,000 of controllable assets was computed in the ROI part of this illustration by multiplying \$1,000,000 of old controllable assets by 120%.

Fourth, the new amount of controllable revenues has to be forecasted using the unchanging earnings ratio as follows:

$$25\% = \frac{\$164,000}{\text{Controllable revenues}}$$

$$\text{Controllable revenues} = \frac{\$164,000}{25\%} = \$656,000$$

Finally, the minimum selling price is found as follows:

$$\begin{aligned} \text{Selling price} &= \frac{\text{Forecasted revenues}}{\text{Forecasted units to be sold}} \\ &= \frac{\$656,000}{500,000 \text{ units}} \\ &= \$1.31 \text{ per paper laundry bag} \end{aligned}$$

As part of the planning function, investment center managers will have to deal with, on a regular basis, many other situations comparable to the one just examined. Regardless of the problem of whether the evaluation of their performance is based on return on investment or residual income, investment center managers will have to be prepared to make important decisions that affect controllable costs, controllable revenues, and controllable assets. To the degree that the fundamental concepts of cost behavior and relevant costing are observed and the selected technique is carefully applied,

investment center decision making will have that much better chance of being successful.

BOTTOM LINE

- Successful company operations result from careful planning and control of all company activities. The success of company operations as a whole depends on the success of its cost, profit, and investment centers.
- Responsibility center performance evaluation is a function of (1) a comparison of beginning-of-the-period pro forma reports that delineate *expected performance* with end-of-the-period post-hoc reports that delineate *actual performance* and (2) an investigation of resultant variances.
- The most effective tools yet devised for measuring responsibility center performance are as follows: Cost center managers should compare budgeted with actual controllable costs; profit center managers should compare budgeted with actual controllable income; and investment center managers should compare either budgeted with actual return on investment or budgeted with actual residual income.
- (From the appendix): Gross profit analysis is one of the most fruitful areas for management to look for improving profit and investment center operations. In-depth analysis of the changes in sales, costs, and gross profit provides a thorough understanding of the steps needed to bring actual operations more in line with budgeted expectations.
- (From the appendix): The net change in gross profit is usually a combination of changes in selling prices, volume, cost, and, for multiproduct firms, sales mix and pure volume if the multiple products are substitutes. Each of these factors can be isolated, and the amount that each factor has contributed to the net change in gross profit can be identified. Different departments will be responsible for the various factors and should explain the reason for changes in a specific factor.

APPENDIX: GROSS PROFIT ANALYSIS

If a profit center manager's performance is not up to expectations expressed in terms of controllable income or if an investment center manager's performance is not up to expectations expressed in terms of either return on investment or residual income, an investigation may be necessary to determine the cause of the unfavorable variance(s). One useful technique that will help to explain changes in revenues and changes in costs is called *gross profit analysis*.

Analysis of gross profit is a continuous and intensive process. Analysis of gross profit can be made in a manner similar to the analysis of standard cost variances, as will be described in Chapter 24. It is possible to analyze gross profit whether standard costs are used or not. In this chapter the factors that directly affect gross profit will be discussed. *Gross profit*, sometimes called *gross margin*, is the excess of sales over the cost of sales. This differs from contribution margin, which is the excess of sales over *all* variable costs, including variable manufacturing, selling, and administrative costs. It is important to note that contribution margin analysis may be done in a manner virtually identical to this chapter's presentation of gross profit analysis.

Change in Gross Profit

In analyzing the change in gross profit, a comparison can be made between budgeted and actual operations for the current year or between actual operations for the prior year and for the current year. Where a budget has been carefully prepared, it is usually preferable to compare actual with budget in that it best measures performance in terms of what actually happened as compared with what should have happened. The principal causes of a difference in gross profit are changes in sales price, sales volume, costs, and, for multiproduct firms, product mix, if and only if the multiple products are substitutes.

Analyzing Change in Gross Profit

In analyzing the change in gross profit, the actual gross profit for the current year will be compared with that of the budgeted gross profit. To make the comparison simple, assume that the Englewood Company manufactures and sells a single product.

As can be seen in Table 12.16, sales increased by \$2,998, or 6.0% ($\$2,998 \div \$50,000$). However the cost of sales also increased, in the amount of \$2,120 or 7.1% ($\$2,120 \div \$30,000$), which was greater than the increase in sales. Therefore, the gross profit ratio decreased from 40% to 39.4%. The \$878 increase in gross profit represented an increase of only 4.4% ($\$878 \div \$20,000$) over the budgeted amount of gross profit. The amount of gross profit must be high enough to provide for selling, administrative, and all other costs, including income taxes. In addition, it must also be high enough to provide an adequate amount of controllable income for a profit center or an adequate amount of controllable income on controllable assets for an investment center. Thus, responsibility center managers must be made aware of any significant changes in gross profit and their possible causes so that a variance investigation can be undertaken if deemed appropriate under the circumstances.

In most companies, two important ratios are the cost of sales ratio and the gross profit ratio. The *cost of sales ratio (CSR)* is the relationship of cost of sales to sales. The *gross profit ratio (GPR)* is the relationship of gross profit to sales. In the comparison in Table 12.16, there was a budgeted GPR of 40.0% ($\$20,000 \div \$50,000$) in Year 2 and an actual GPR of 39.4% ($\$20,878 \div \$52,998$) in Year 2. The budgeted and actual CSR in Table 12.16 were 60.0% ($\$30,000 \div \$50,000$) and 60.6% ($\$32,120 \div \$52,998$), respectively, for Year 2. The CSR plus the GPR must always equal 100% in that they are complements of each other. A potentially bad situation is developing for the Englewood Company because the GPR decreased while the CSR increased. This means that in Year 2 it cost more than expected to produce the units in relation to their selling price. Any change in CSR over GPR should be further analyzed into the following three possible variances:

1. *Volume variance.* When volume changes, total sales and total cost of sales will change and, therefore, gross profit will change.
2. *Sales price variance.* When selling price per unit changes, total sales will change and, therefore, gross profit will change.
3. *Cost variance.* When cost per unit changes, total cost of sales will change and, therefore, gross profit will change.

The volume variance is found in Table 12.17 by multiplying the budgeted gross profit per unit by the difference between the budgeted volume

TABLE 12.16 Englewood Company Comparative Gross Profit Statement Year 2

| | Budget | Actual | Change | % |
|---------------------------|-----------------|-----------------|-----------------|------------|
| Sales | \$50,000 | \$52,998 | + \$2,998 | 6.0 |
| Cost of sales | <u>30,000</u> | <u>32,120</u> | <u>- 2,120</u> | <u>7.1</u> |
| Gross profit | <u>\$20,000</u> | <u>\$20,878</u> | <u>+ \$ 868</u> | <u>4.4</u> |
| Cost of sales ratio (CSR) | 60.0% | 60.6% | | |
| Gross profit ratio (GPR) | <u>40.0%</u> | <u>39.4%</u> | | |
| Total | <u>100.0%</u> | <u>100.0%</u> | | |
| Cost Data per Unit | | | | |
| | Budget | Actual | Change | |
| Volume | 5,000 | 4,818 | - 182 | |
| Sales price | \$10.00 | \$11.00 | + \$1.00 | |
| Cost | \$6.00 | \$6.67 | + \$.67 | |
| Gross profit | \$4.00 | \$4.33 | + \$.33 | |

and the actual volume. The volume variance equals an unfavorable \$728 (because 182 fewer units were actually sold than budgeted) and reflects either the failure of the production department manager to generate the level of productive activity that should have been generated or the failure of the marketing department manager to generate the level of sales activity that should have been generated.

The sales price variance is found in Table 12.17 by multiplying the actual volume by the difference between the budgeted sales price per unit and the actual sales price per unit. The sales price variance equals a favorable \$4,818 and indicates, at least superficially, the success of the marketing department manager in increasing total dollar sales via an increase in the unit sales price. It is quite likely that the \$728 unfavorable volume variance (because actual units were 182 units less than budgeted units) was caused by the \$1 per unit increase in the sales price. However, the favorable sales price variance of \$4,818 more than compensates for the unfavorable volume variance of \$728. The strategy employed by the marketing department manager

TABLE 12.17 Englewood Company Three-Factor Analysis of Variance for Gross Profit

The computation of the volume variance is based on the following formula:

$$\begin{aligned} \text{Volume variance} &= (\text{Budgeted volume} - \text{Actual volume}) \times \left(\begin{array}{l} \text{Budgeted} \\ \text{gross profit} \\ \text{per unit} \end{array} \right) \\ &= (5,000 \text{ units} - 4,818 \text{ units}) \times \$4.00 \text{ per unit} \\ &= 182 \text{ units} \times \$4.00 \text{ per unit} \\ &= \$728 \text{ unfavorable} \end{aligned}$$

The computation of the sales price variance is based on the following formula:

$$\begin{aligned} \text{Sales price variance} &= (\text{Budgeted sales price per unit} - \text{Actual sales price per unit}) \\ &\quad \times (\text{Actual volume}) \\ &= (\$10 \text{ per unit} - \$11 \text{ per unit}) \times 4,818 \text{ units} \\ &= -\$1 \text{ per unit} \times 4,818 \text{ units} \\ &= -\$4,818 \text{ favorable} \end{aligned}$$

The computation of the cost variance is based on the following formula:

$$\begin{aligned} \text{Cost variance} &= (\text{Budgeted cost per unit} - \text{Actual cost per unit}) \times (\text{Actual volume}) \\ &= (\$6.00 \text{ per unit} - \$6.67 \text{ per unit}) \times 4,818 \text{ units} \\ &= -\$0.67 \text{ per unit} \times 4,818 \text{ units} \\ &= -\$3,212 \text{ unfavorable} \end{aligned}$$

(increase unit sales price followed by a small reduction in sales volume) was very successful this time. Next time, of course, the exact same strategy might backfire with a favorable sales price variance more than wiped out by an unfavorable volume variance if the price elasticity of demand, which should be considered, increases.

The cost variance is found in Table 12.17 by multiplying the actual volume by the difference between the budgeted cost per unit and the actual cost per unit. The cost variance equals an unfavorable \$3,212 and reflects the failure of the production department manager to maintain tight control over direct materials, direct labor, and/or factory overhead.

The total change in gross profit of \$878 can now be summarized as follows:

| | | |
|------------------------|----------------|-------------|
| Volume variance | \$728 | unfavorable |
| Sales price variance | (4,818) | favorable |
| Cost variance | <u>3,212</u> | unfavorable |
| Change in gross profit | <u>\$(878)</u> | favorable |

Multiple Products

The preceding example used data from the Englewood Company, which manufactured only one product. Most manufacturing companies make more than one product, and the sales, cost, and gross profit vary widely among the products. To illustrate, consider the data for the Egan Manufacturing Company, which makes and sells three products, X, Y, and Z. The actual data will be compared with the budgeted data for the year 200X. The analysis of gross profit can be approached similar to the analysis of gross profit for a single-product firm with the exception of the volume variance if the multiple products are substitutes. The relevant data that will be used appears in Tables 12.18 and 12.19.

As can be seen in Table 12.18, the Egan Company had expected to earn a gross profit of \$45,000 on estimated sales of 60,000 units, for an average gross profit of \$0.75 per unit, or 17.3% of sales. The actual results (Table 12.19) showed sales of 62,000 units, or 103.3% ($62,000 \div 60,000$) of the target. However, the actual gross profit was only \$33,230, or only 73.8% ($\$33,230 \div \$45,000$) of the budgeted gross profit, and the actual gross profit per unit was only \$0.54, compared with the budgeted gross profit per unit of \$0.75. The average actual GPR was 12.8% of sales, as compared with average budgeted GPR of 17.3% of sales.

If sales prices, volume, and costs had been the same as budgeted, the gross profit would have been exactly \$45,000. However, as shown in Table 12.19, the gross profit was only \$33,230. What factors caused the decrease

TABLE 12.18 Egan Manufacturing Company Budgeted Gross Profit Statement for 200X

| Product Name | Budgeted Units Sold | Budgeted Sales | | Budgeted Cost | | Budgeted Gross Profit | | |
|--------------|---------------------|---------------------|-----------|---------------------|-----------|-----------------------|----------|-------------------|
| | | Price | Amount | Unit | Amount | Unit | Amount | % |
| X | 30,000 | \$5.00 | \$150,000 | \$4.00 | \$120,000 | \$1.00 | \$30,000 | 20.0 |
| Y | 20,000 | 4.00 | 80,000 | 3.40 | 68,000 | 0.60 | 12,000 | 15.0 |
| Z | 10,000 | 3.00 | 30,000 | 2.70 | 27,000 | 0.30 | 3,000 | 10.0 |
| Total | 60,000 | \$4.33 ^a | \$260,000 | \$3.58 ^b | \$215,000 | \$0.75 ^c | \$45,000 | 17.3 ^d |

Computations of weighted average:

^a $\$260,000 \div 60,000$

^b $\$215,000 \div 60,000$

^c $\$45,000 \div 60,000$

^d $\$45,000 \div \$260,000$

TABLE 12.19 Egan Manufacturing Company Actual Gross Profit Statement for 200X

| Product Name | Actual Units Sold | Actual Sales | | Actual Cost | | Actual Gross Profit | | |
|--------------|-------------------|---------------------|-----------|---------------------|-----------|---------------------|----------|-------------------|
| | | Price | Amount | Unit | Amount | Unit | Amount | % |
| X | 23,000 | \$5.50 | \$126,500 | \$4.94 | \$113,620 | \$0.56 | \$12,880 | 10.2 |
| Y | 26,500 | 3.50 | 92,750 | 2.85 | 75,525 | 0.65 | 17,225 | 18.6 |
| Z | 12,500 | 3.25 | 40,625 | 3.00 | 37,500 | 0.25 | 3,125 | 7.7 |
| Total | 62,000 | \$4.19 ^a | \$259,875 | \$3.65 ^b | \$226,645 | \$0.54 ^c | \$33,230 | 12.8 ^d |

Computations of weighted average:

^a $\$259,875 \div 62,000$

^b $\$226,645 \div 62,000$

^c $\$33,230 \div 62,000$

^d $\$33,230 \div \$259,875$

in gross profit of \$11,770, $(\$45,000 - \$33,230)$ or 26.2% $[(\$45,000 - \$33,230) \div \$45,000]$? The factors that caused this decrease will now be determined.

There were large differences between budgeted and actual results for the three individual products in terms of sales price per unit and cost per unit. The sales price variance and the cost variance will be analyzed in Tables 12.20 and 12.21, respectively, using the same formulas that were developed for single-product firms. That is, the sales price variances of \$11,500 (favorable) for product X, \$13,250 (unfavorable) for product Y, and \$3,125 (favorable) for product Z can be found in Table 12.20 by multiplying the actual volume by the difference between the budgeted sales price per unit and the actual sales price per unit.

The cost variances can be found in Table 12.21 by multiplying the actual volume by the difference between the budgeted cost per unit and the actual cost per unit. The cost variances for products X, Y, and Z are \$21,620 (unfavorable), \$14,575 (favorable), and \$3,750 (unfavorable), respectively.

As to the possible causes of the sales price and cost variances, they can be determined, if desired, through the application of variance investigation procedures.

In the analysis of gross profit variances, the only substantive difference between a multiproduct firm and a single-product firm is in the computation of a volume variance. In a multiproduct firm, the conventional volume variance is subdivided into a *pure* volume variance and a *mix* variance if the multiple products are substitutes. In the pure volume variance, the effect of changes in the physical volume of each product sold (independent of

TABLE 12.20 Egan Manufacturing Company Analysis of Sales Price Variances for 200X

| Formula | Product X | Product Y | Product Z |
|---|---|---|--|
| (Budgeted sales price minus actual sales price) times actual volume | $(\$5.00 - \$5.50) \times 23,000$ $-\$0.50 \times 23,000$ $-\$11,500$ favorable | $(\$4.00 - \$3.50) \times 26,500$ $\$0.50 \times 26,500$ $\$13,250$ unfavorable | $(\$3.00 - \$3.25) \times 12,500$ $-\$0.25 \times 12,500$ $-\$3,125$ favorable |

TABLE 12.21 Egan Manufacturing Company Analysis of Cost Variances for 200X

| Formula | Product X | Product Y | Product Z |
|---|---|---|--|
| (Budgeted cost minus actual cost) times actual volume | $(\$4.00 - \$4.94) \times 23,000$ $-\$0.94 \times 23,000$ $-\$21,620$ unfavorable | $(\$3.40 - \$2.85) \times 26,500$ $\$0.55 \times 26,500$ $\$14,575$ favorable | $(\$2.70 - \$3.00) \times 12,500$ $-\$0.30 \times 12,500$ $-\$3,750$ unfavorable |

TABLE 12.22 Egan Manufacturing Company Analysis of Volume Variances (Nonsubstitutes) for 200X

| Formula | Product X | Product Y | Product Z |
|---|--|--|--|
| (Budgeted volume minus actual volume) times budgeted gross profit | $(30,000 - 23,000) \times \1.00 7,000 × \$1.00 \$7,000 unfavorable | $(20,000 - 26,500) \times \0.60 -6,500 × \$0.60 -\$3,900 favorable | $(10,000 - 12,500) \times \0.30 -2,500 × \$0.30 -\$750 favorable |

TABLE 12.23 Egan Manufacturing Company Analysis of Pure Volume Variances (Substitutes) for 200X

| Formula | Product X | Product Y | Product Z |
|--|--|--|--|
| (Budgeted volume minus actual volume) times budgeted average gross profit ^a | $(30,000 - 23,000) \times \0.75 7,000 × \$0.75 \$5,250 unfavorable | $(20,000 - 26,500) \times \0.75 -6,500 × \$0.75 -\$4,875 favorable | $(10,000 - 12,500) \times \0.75 -2,500 × \$0.75 -\$1,875 favorable |

$$\begin{aligned}
 \text{a Budgeted average gross profit} &= \frac{\text{Total budgeted gross profit}}{\text{Total budgeted units}} \\
 &= \frac{\$45,000}{60,000 \text{ units}} = \$0.75 \text{ per unit}
 \end{aligned}$$

each other) is computed; and in the mix variance, the effect of changes in the physical volume of the more profitable and/or less profitable products (in relation to each other) is computed. A pure volume variance and a mix variance have no meaning if the products are not substitutes for each other. The two variances, however, can be computed mathematically, but it is crucial to remember that they are meaningless. In fact, first assume that the three products are not substitutes. In Table 12.22, the \$7,000 (unfavorable), \$3,900 (favorable), and \$750 (favorable) volume variances for products X, Y, and Z, respectively, were found as if they were produced by a single-product firm by multiplying the budgeted gross profit per unit by the difference between the budgeted volume and the actual volume.

If products X, Y, and Z are substitutes, a pure volume variance can be computed for each product in Table 12.23 by multiplying the budgeted average gross profit per unit by the difference between the budgeted volume and the actual volume. The budgeted average gross profit per unit of \$0.75 is found by taking the total budgeted gross profit of \$45,000 and dividing by the total budgeted units of 60,000. Exactly like the volume variance, the pure volume variance is favorable if more actual units are sold than budgeted and unfavorable if fewer actual units are sold than budgeted. There-

TABLE 12.24 Egan Manufacturing Analysis of Mix Variances (Substitutes) for 200X

| Formula | Product X | Product Y | Product Z |
|---|--|---|---|
| (Budgeted volume minus actual volume) times | (30,000 – 23,000) × –\$0.25 ^a | (20,000 – 26,500) × \$0.15 ^b | (10,000 – 12,500) × \$0.45 ^c |
| (budgeted average gross profit minus budgeted gross profit) | 7,000 × – \$0.25 –\$1,750 unfavorable | –6,500 × \$0.15 –\$975 unfavorable | –2,500 × \$0.45 –\$1,125 unfavorable |

Computations

^a \$0.75 per unit – \$1.00 per unit = –\$0.25 per unit

^b \$0.75 per unit – \$0.60 per unit = \$0.15 per unit

^c \$0.75 per unit – \$0.30 per unit = \$0.45 per unit

fore, the pure volume variances are \$5,250 (unfavorable) for product X, \$4,875 (favorable) for product Y, and \$1,875 (favorable) for product Z.

A mix variance can be computed for each product as shown in Table 12.24 by multiplying the difference between the budgeted average gross profit per unit and the budgeted gross profit per unit by the difference between the budgeted volume and the actual volume. The mix variances are \$1,750 (unfavorable) for product X, \$975 (unfavorable) for product Y, and \$1,125 (unfavorable) for product Z. A mix variance is unfavorable if a company sold more units of the less profitable product or sold fewer units of the more profitable product. Conversely, a mix variance is favorable if a company sold fewer units of the less profitable product or sold more units of the more profitable product.

The less profitable product and more profitable product are determined by comparing the individual product’s budgeted gross profit per unit to the budgeted average gross profit per unit. If the individual product’s budgeted gross profit per unit is greater, the product is more profitable but if the individual product’s budgeted gross profit per unit is less, the product is less profitable.

Product X is a more profitable product because its budgeted gross profit of \$1.00 per unit is greater than the budgeted average gross profit of \$0.75 per unit. Products Y and Z are less profitable products because their budgeted gross profits of \$0.60 per unit and \$0.30 per unit, respectively, are less than the budgeted average gross profit of \$0.75 per unit.

Note that the pure volume variance plus the mix variance for each product equals each product’s volume variance. For example, the pure volume variance for product X is \$5,250 (unfavorable) and the mix variance for product X is \$1,750 (unfavorable). The sum of the two variances equals an unfavorable \$7,000, which agrees with the volume variance in Table 12.22 for product X.

TABLE 12.25 Egan Manufacturing Company Summary of Variances for 200X

| Variance | Product X | Product Y | Product Z | Total |
|---------------------------|-------------------|------------------|----------------|-------------------|
| Sales price (Table 12.20) | \$11,500 F | \$13,250 U | \$3,125 F | \$1,375 F |
| Cost (Table 12.21) | 21,620 U | 14,575 F | 3,750 U | 10,795 U |
| Pure volume (Table 12.23) | 5,250 U | 4,875 F | 1,875 F | 1,500 F |
| Mix (Table 12.24) | <u>1,750 U</u> | <u>975 U</u> | <u>1,125 U</u> | <u>3,850 U</u> |
| | <u>\$17,120 U</u> | <u>\$5,225 F</u> | <u>\$125 F</u> | <u>\$11,770 U</u> |

U = unfavorable

F = favorable

The total unfavorable change in gross profit of \$11,770 can now be summarized in Table 12.25 (assuming the multiple products are substitutes).

Management Analysis

The preceding summaries and analyses provide ample motivation for management to initiate a variance investigation leading to possible corrective action, especially those analyses that show unfavorable differences between budgeted and actual operations. For example, if there has been a drop from expected sales of the product with the highest gross profit per unit, it may be advisable to increase the advertising budget for succeeding periods to recoup the “lost” sales for that product.

As can be seen, product X units sold were 7,000 (30,000 per Table 12.18 less 23,000 per Table 12.19) below the budgeted quantity, which had a significant effect on gross profit. Product Y had an increase of 6,500 units over budget and product Z had an increase of 2,500 units over budget.

The marketing department should be called on to explain the reasons for these changes, especially the increase in sales of the less profitable products, Y and Z. Sometimes a bonus plan may be set up in such a way that incentive compensation is based on quantities sold rather than on higher rewards for higher gross profit items. Perhaps the bonus plan should be revised to consider the sale of higher gross profit items. As can be seen, sales prices for products X and Z were increased by \$0.50 and \$0.25, respectively (Table 12.19). Price for product Y was decreased by \$0.50 per unit (Table 12.19). The control of sales prices is usually also under the control of the marketing department. The net favorable effect of sales price increases of \$1,375 (Table 12.24) was more than offset by the net unfavorable effect of the sales mix of \$3,850 (Table 12.24).

Transfer Pricing

AGENDA

- Item 1* Define transfer pricing and explain the four criteria for evaluating different transfer pricing methods.
- Item 2* Compute transfer prices using the cost, cost plus, negotiated price, and market price methods.
- Item 3* Understand the computation of and need for a synthetic market price method.
- Item 4* Describe a dual transfer pricing system.
- Item 5* Understand the tax issues associated with transfer pricing by corporations operating in more than one country.
- Item 6* Describe the various methods that are acceptable for determining the arm's-length price in international transfer pricing.

Many companies today are structured on some variation of vertical integration in which the finished product of one responsibility center becomes the raw material of another responsibility center. For example, in a paper manufacturing company the output of the paper division may be sold to outside customers or may be transferred to other company plants that manufacture paper bags or corrugated boxes. Here the problem of intra-company transfer pricing arises. Several different transfer pricing methods are in use, each with its own advantages and disadvantages.

A *transfer price* is the dollar basis used to quantify the transfer of goods or services from one responsibility center to another. Transfer pricing is an important topic. The explosive growth in most companies as a result of either internal expansion or external mergers has accelerated the trend toward decentralization and intracompany transactions.

A transfer price should be thought of as a *signal* sent to the buying responsibility center to take a predetermined course of action. On the one hand, if the transfer price charged by the selling responsibility center is

greater than the outside market price, the transfer price is a *signal* to the buying responsibility center to buy from an outside supplier. On the other hand, if the transfer price charged by the selling responsibility center is less than or equal to the outside market price, the transfer price is a *signal* to the buying responsibility center to buy from the selling responsibility center.

Transfer pricing has become one of the most important and sometimes most controversial elements in performance measurement. The internal transfer of goods or services can impact positively or negatively on the performance measures used for responsibility centers just the same as the external transfer of goods and services. It should be obvious that a conflict is likely to arise in an organization between responsibility center managers because the “buyer” wants the transfer price to be as low as possible while the “seller” wants the transfer price to be as high as possible.

When an exchange of goods or services takes place between a responsibility center and an external party, the forces of demand and supply according to the microeconomic rules of the marketplace determine the price that the buyer is to pay and the seller is to receive if the transaction is to be consummated. An exchange of goods or services between a responsibility center and an internal party, however, poses another potentially more serious problem than performance evaluation. What transfer price should be set so that buying and selling responsibility centers, acting in their own best interests, will at the same time act in the best interests of the company as a whole? This is a serious question because *suboptimal decision making* will result if either (1) the buying responsibility center manager goes to an outside supplier to satisfy his needs when he should have gone to the selling responsibility center manager or (2) the buying responsibility center manager goes to the selling responsibility center manager to satisfy his needs when he should have gone to an outside supplier. Upper-level management may insist that the buying and selling responsibility centers, although they are theoretically autonomous units, always take only those actions that are in the best interests of the company as a whole; undesirable behavioral consequences are likely to result from *pseudodecentralization*.

The use of transfer prices by cost centers will be discussed later in this book. The choice of a transfer pricing method for cost centers is limited, of necessity, to cost. However, if the actual costs of production departments or service departments are used, their managers will have little if any incentive to control costs. As a consequence, any inefficiencies of the selling cost center are passed along to the buying cost center.

A simple solution calls for the use of standard costs in place of actual costs for production departments and service departments. It is the ideal transfer price for cost center exchanges of goods or services. By leaving favorable or unfavorable variances in the selling cost center, the buying cost

center will be charged a “fair” transfer price equal to the cost of the goods or services that should have been incurred by the selling cost center. The company as a whole will benefit from the use of standard costs because its selling cost centers will have maximum incentive to control their costs and its buying cost centers will no longer be unfairly penalized by having to pay for the inefficiencies of the selling cost centers.

In this chapter we discuss transfer pricing for profit and investment centers. In accounting for their intracompany transactions, a number of cost-based transfer pricing methods will be examined. Because of the overwhelming advantage of standard costs over actual costs just observed in relation to cost centers, any reference to cost (whether it be variable cost, full cost, or some other cost-based transfer pricing method) will be understood to be standard cost and not actual cost. In the last section of this chapter, we will look at the issues associated with transfer pricing by multinational corporations. The focus here shifts from performance measurement and evaluation to tax issues.

TRANSFER PRICING METHODS

The transfer pricing method used must be the one most beneficial to the company. Much has been written in the management accounting literature concerning the motivation and the autonomy of profit or investment center managers. Most companies today give careful consideration to these behaviorally oriented factors in establishing responsibility centers and in selecting managers for them. There is a possibility that at times the interests of the responsibility center manager may conflict with the interests of the company as a whole. In such cases upper-level management may act to ensure that the profit or investment center’s interests are made congruent or brought into line with total company interests.

The following four interrelated criteria should be used to evaluate the transfer pricing methods that are currently being used by profit or investment centers:

1. *Goal congruence.* The transfer price that is set should send a signal to both the buying and selling responsibility centers to take whatever action is in their own best interests and, at the same time, is in the best interests of the company as a whole.
2. *Motivation.* Because motivation is a difficult-to-define phenomenon that drives individuals to accomplish goals, the transfer price should not interfere with the process wherein the buying responsibility center

manager rationally strives to minimize his costs and the selling responsibility center manager rationally strives to maximize his revenues.

3. *Autonomy.* In a decentralized company, the managers of the buying and selling responsibility centers should not be coerced by upper-level management into making an internal transfer. Instead, each responsibility center manager should be free to satisfy his own needs either internally or externally at the best possible price.
4. *Performance evaluation.* Regardless of whether the buying and selling responsibility centers are cost, profit, or investment centers, the transfer price should not adversely affect the fairness of the performance evaluation process and the incentive plans that are based thereon.

Each of the various transfer pricing methods currently in use will be discussed *only* in relation to profit centers for two reasons: First, transfer prices impact on profit and investment centers in an identical manner; and second, the discussion will be greatly facilitated by being restricted to a single type of responsibility center, which is based on the following comprehensive illustration.

Comprehensive Illustration

The Drake Company has a large number of profit centers, including B (representing the buying profit center) and S (representing the selling profit center). Profit center B needs 20,000 units of component 12. Component 12 is an integral part of product Z, which is manufactured in profit center B and sold for \$24. Component 12 can be purchased by profit center B either externally at \$19 per unit from the Thorn Company or internally from profit center S. In addition to component 12, profit center S regularly manufactures between 80,000 and 100,000 units of component 13, which is sold at a 60% markup on full cost ($\$21.60 = 160\% \times \13.50). Component 13 is slightly different from component 12 because of the use of more costly direct materials; so it cannot be substituted for component 12 in the manufacture of product Z. The standard and actual controllable costs of profit centers S and B for production and sale of components 12 and 13 and product Z are shown in Table 13.1.

Each of the transfer pricing methods in current use will be discussed from the perspective of the buying profit center, the selling profit center, the company as a whole, and the four interrelated criteria listed above.

Figure 13.1 presents a pictorial representation of the transfer pricing situation that confronts the Drake Company; it will enhance the examination of each of the various transfer pricing methods.

TABLE 13.1 Data for Comprehensive Illustration; Standard and Actual Controllable Costs of Profit Centers S and B for Production and Sale of Components 12 and 13 and Product Z

| | Unit Costs | | | | | |
|---------------------------|----------------------------------|----------------|----------------------------------|----------------|-------------------------------|----------------|
| | Profit Center S, Component 12 | | Profit Center S, Component 13 | | Profit Center B, Product Z | |
| | Standard Cost | Actual Cost | Standard Cost | Actual Cost | Standard Cost | Actual Cost |
| Transfer price | | | | | \$? | \$? |
| Direct materials | \$2.20 | \$2.30 | \$3.00 | \$3.20 | 0.50 | 0.55 |
| Direct labor | 2.00 | 2.25 | 2.00 | 2.25 | 1.00 | 1.05 |
| Variable factory overhead | 4.00 | 3.80 | 4.00 | 3.80 | 1.50 | 1.60 |
| Fixed factory overhead | <u>1.50^a</u> | <u>1.50</u> | <u>1.50^a</u> | <u>1.50</u> | <u>0.40^b</u> | <u>0.40</u> |
| Variable selling | 2.50 | 2.55 | 2.50 | 2.55 | 0.30 | 0.35 |
| Fixed selling | <u>0.50^a</u> | <u>0.50</u> | <u>0.50^a</u> | <u>0.50</u> | <u>0.10^b</u> | <u>0.10</u> |
| Total controllable costs | <u>\$12.70</u> | <u>\$12.90</u> | <u>\$13.50</u> | <u>\$13.80</u> | <u>\$?</u> | <u>\$?</u> |

^a Unit fixed costs are based on the production and sale of a total of 100,000 units.

^b Unit fixed costs are based on the production and sale of a total of 20,000 units.

FIGURE 13.1 Transfer Pricing Diagram

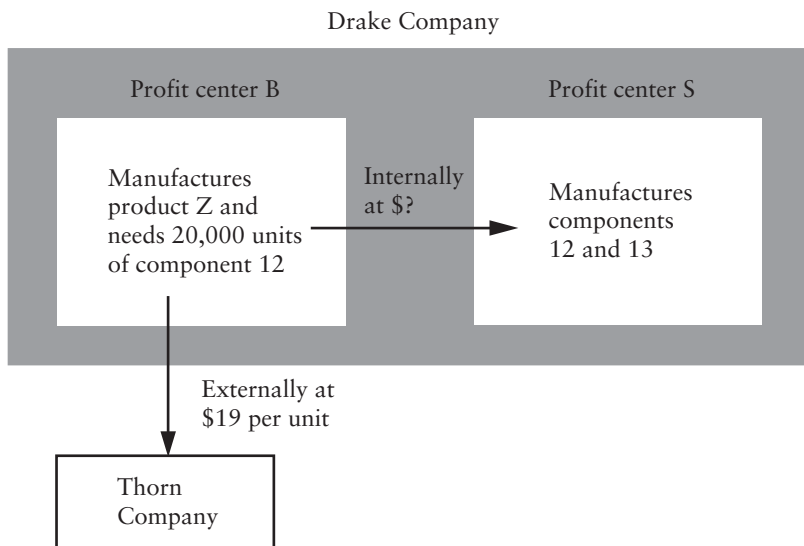

Cost

A transfer price for component 12 on the basis of cost could be any one of the following per-unit amounts:

| | Actual Cost | Standard Cost |
|---------------|----------------------|----------------------|
| Variable cost | \$10.90 ^a | \$10.70 ^b |
| Full cost | 12.90 | 12.70 |

^a \$2.30 + \$2.25 + \$3.80 + \$2.55

^b \$2.20 + \$2.00 + \$4.00 + \$2.50

As already stated with respect to cost centers, where actual variable cost or actual full cost is used, there may not be adequate incentive for the selling profit center to reduce production and/or selling inefficiencies since they can be passed along to the buying profit center. The use of standard costs should help to lessen if not eliminate the problem of transferring variances so that all the examples that follow will be restricted to standard costs.

In the first illustration, the transfer price will be set equal to variable cost (\$10.70). The relevant incomes for profit center B and the company are:

| | Profit Center B (Internal Transfer) | Company as a Whole (Internal Transfer) |
|-----------------------------------|--|---|
| Market price of product Z | \$24.00 | \$24.00 |
| Relevant costs: | | |
| Variable costs of profit center B | \$3.30 ^a | \$3.30 |
| Transfer price of profit center S | <u>10.70</u> | <u>10.70</u> |
| Total relevant costs | <u>\$14.00</u> | <u>\$14.00</u> |
| Relevant income | <u>\$10.00</u> | <u>\$10.00</u> |

^a \$0.50 + \$1.00 + \$1.50 + \$3.30

A transfer price set equal to variable cost will lead to goal congruence. That is, the \$10.70 per unit transfer price sends a signal to profit center B to buy 20,000 units of component 12 from profit center S instead of from the Thorn Company at \$19 per unit. Both profit center B and the company as a whole will have relevant income of \$10.00 per unit if the internal transfer takes place. Unfortunately, the motivation and performance evaluation criteria are violated from the viewpoint of profit center S, which realizes *no* profit at a transfer price of \$10.70 per unit. Although no loss would be charged against profit center S in the short run, a failure to cover at least the full costs of \$12.70 per unit would result in a long-run loss. If profit center S

objects to making the transfer but is forced to do so by upper-level management, then the autonomy criterion would not be satisfied.

In the second illustration, the transfer price will be set equal to full cost (\$12.70). The relevant incomes for profit center B and the company are:

| | Profit Center B (Internal Transfer) | Company as a Whole (Internal Transfer) |
|-----------------------------------|--|---|
| Market price of product Z | \$24.00 | \$24.00 |
| Relevant costs: | | |
| Variable costs of profit center B | \$3.30 | \$3.30 |
| Transfer price of profit center S | <u>12.70</u> | <u>10.70</u> |
| Total relevant costs | <u>\$16.00</u> | <u>\$14.00</u> |
| Relevant income | <u>\$ 8.00</u> | <u>\$10.00</u> |

A transfer price set equal to full costs will still lead to goal congruence. Profit center B will be sent a signal to buy 20,000 units of component 12 from profit center S at \$12.70 per unit instead of from the Thorn Company at \$19 per unit. With per-unit relevant incomes of \$8 and \$10, respectively, profit center B and the company as a whole will benefit from the internal transfer. Once again, profit center S does not realize a profit at a transfer price of \$12.70 per unit. As a consequence, the criteria of motivation and performance evaluation are still not satisfied. The autonomy criterion would also pose a problem if upper-level management enforced a transfer, assuming profit center S was unwilling to do so.

While it might appear at first glance that a full-cost transfer price sends the correct signal to the buying profit center to take an action in its best interests as well as in the best interests of the company as a whole, that is certainly not always the case.

In this comprehensive illustration, an outside purchase price of \$19 per unit was assumed. Suppose the Thorn Company temporarily lowers its price (just for this illustration) to \$11.50 per unit. There is no longer a transfer price set equal to full cost that leads to goal congruence. Now the manager of profit center B will be sent an *incorrect* signal to buy 20,000 units of component 12 from the Thorn Company at \$11.50 per unit instead of from profit center S at a full-cost transfer price of \$12.70 per unit.

As far as profit center B is concerned, there is a \$1.25 per unit advantage to buying from the Thorn Company (\$12.70 – \$11.50). Unfortunately, the company as a whole is penalized \$0.80 per unit, the difference between Thorn Company's outside purchase price of \$11.50 per unit and the relevant variable costs of \$10.70 per unit to make and sell component 12 in profit center S.

Cost Plus

A cost-plus transfer price is used fairly often to overcome the motivation and performance evaluation problems associated with transfer prices set equal to either variable cost or full cost. The cost-plus method is used as an approximation of market price, which was the most popular transfer price reported in surveys of managerial accountants in the late 1970s and early 1980s. Often this is considered a practical approach to the problem of divergent profit center and corporate interests. The base cost used in determining the transfer price varies with different companies. In some cases the profit center manager may want to base transfer prices on variable costs plus profit whereas in other cases that manager may want fixed costs also to be included. Even though the transfer price will be higher than full cost, it may still be in the best interests of the buying responsibility center and the company as a whole to transfer the product within the company.

For this to be true in this comprehensive illustration, the cost-plus transfer price would have to be less than the \$19 per unit outside purchase price. The buying responsibility center would be sent the signal that would be in the best interests of the company as a whole. That is, profit center B should buy 20,000 units of component 12 from profit center S. The company as a whole would enjoy an advantage of \$8.30 per unit, the difference between the relevant variable costs of \$10.70 per unit to make and sell component 12 in profit center S and the outside purchase price of \$19 per unit. For illustrative purposes, the cost-plus transfer price will now be set equal to an amount greater than the \$19 per unit outside purchase price to demonstrate goal incongruence.

In the third illustration, the transfer price will be set equal to full cost plus normal markup. Full cost for profit center S is \$12.70 per unit and the normal markup is 60% so that the transfer price equals \$20.32 per unit ($\$12.70 \times 160\%$). The relevant incomes for profit center B and the company are:

| | Profit Center B (External Transfer) | Company as a Whole (Internal Transfer) |
|-----------------------------------|--|---|
| Market price of product Z | \$24.00 | \$24.00 |
| Relevant costs: | | |
| Variable costs of profit center B | \$3.30 | \$3.30 |
| Outside price | <u>19.00</u> | <u>10.70</u> |
| Total relevant costs | <u>\$22.30</u> | <u>\$14.00</u> |
| Relevant income | <u>\$1.70</u> | <u>\$10.00</u> |

A transfer price set equal to full cost plus markup will not lead to goal congruence, at least in the context of this illustration. With an outside price of \$19 per unit, which is less than the transfer price of \$20.32 per unit, the manager of profit center B will be sent an *erroneous signal* to buy 20,000 units of component 12 from the Thorn Company instead of from profit center S. As a result, the company as a whole is penalized \$8.30 per unit, the difference between Thorn Company's purchase price of \$19 per unit and the relevant variable costs of \$10.70 per unit to make and sell component 12 in profit center S. With respect to the three remaining criteria—motivation, autonomy, and performance evaluation—a cost-plus transfer price leads to their satisfaction from the perspective of both the buying and the selling profit centers.

Any intracompany profit would have to be eliminated, of course, when financial statements are prepared whether it was the result of variable cost-plus or full cost-plus transfer pricing.

Negotiated Price

Generally, a negotiated price arrived at between the buying and selling profit centers gives managers the greatest control over profit. As a result, the performance evaluation criterion is most likely to be satisfied, with the autonomy criterion the most likely to be violated if disputes arise.

In the fourth illustration, assume the two profit center managers negotiate a transfer price equal to full cost plus half the normal markup. Full cost for profit center S is \$12.70 per unit and half the normal markup is 30% so that the transfer price equals \$16.51 per unit ($\$12.70 \times 130\%$). The relevant incomes for profit center B and the company are:

| | Profit Center B (Internal Transfer) | Company as a Whole (Internal Transfer) |
|-----------------------------------|--|---|
| Market price of product Z | \$24.00 | \$24.00 |
| Relevant costs: | | |
| Variable costs of profit center B | \$3.30 | \$3.30 |
| Transfer price of profit center S | <u>16.51</u> | <u>10.70</u> |
| Total relevant costs | <u>\$19.81</u> | <u>\$14.00</u> |
| Relevant income | <u>\$4.19</u> | <u>\$10.00</u> |

It appears that the negotiated transfer price of \$16.51 per unit satisfies all four criteria. However, one of the serious difficulties with this method is that it takes time and a great deal of analysis and data. Also there may be frequent requests for revisions. Possible overemphasis on profit center welfare rather than company welfare may result. Sometimes stalemates may occur

and top management has to step in and resolve conflicts. At times ill feeling may develop between managers that more than offsets the benefits gained.

Market Price

Where a competitive market price exists for the output of a profit center, such as the price charged to outside customers, the market price is thought to be the best transfer price. In fact most managerial accountants believe that the outside market price is the most *objective* measure of the *economic value* of the good or service being transferred.

It is expected, of course, that the market price is one obtained through arm's-length transactions, on the basis of representative quantities. Generally, internal transfers will be made where the selling profit center's product is equal to that of outsiders in quality and price. Often a lower price may be justified, since there will be less selling and administrative expenses, larger purchases will be made, and there is virtually a guaranteed market. The buyer also has assurance of continuing good quality and dependable delivery.

Certain factors have to be considered in using the market price. There may be no market price for the exact product, or there may not even be a market for an intermediate product such as component 12 in this example. A quoted price must be equal in quality, delivery, credit terms, and so on. In some cases prices obtained may not be reliable; they may be distress prices for excess inventory or defective goods. Another point to consider is that an outside bidder who has consistently lost to internal transfers may possibly make an unreliable or deliberately low bid. It is desirable for the buying profit center to maintain contact with more than one supplier so that a reasonable market price can be obtained.

In the fifth illustration, the transfer price will be set equal to the outside market price. The relevant incomes for profit center B and the company are:

| | Profit Center B (Internal Transfer) | Company as a Whole (Internal Transfer) |
|-----------------------------------|--|---|
| Market price of product Z | \$24.00 | \$24.00 |
| Relevant costs: | | |
| Variable costs of profit center B | \$3.30 | \$3.30 |
| Transfer price of profit center S | <u>19.00</u> | <u>10.70</u> |
| Total relevant costs | <u>\$22.30</u> | <u>\$14.00</u> |
| Relevant income | <u>\$1.70</u> | <u>\$10.00</u> |

The use of the outside market price appears on the surface to be an ideal transfer price in that it leads to goal congruence, motivation, autonomy, and performance evaluation. However, there are situations where this approach

will lead to suboptimization (i.e., it will violate the goal congruence criterion). These situations are illustrated below.

In situation 1, assume that profit center S does not have any idle capacity to accommodate profit center B's need for 20,000 units of component 12. The relevant incomes for profit center B and the company are:

| | Profit Center B (Internal Transfer) | Company as a Whole (Internal Transfer) |
|-------------------------------------|--|---|
| Market price of product Z | \$24.00 | \$24.00 |
| Relevant costs: | | |
| Variable costs of profit center B | \$3.30 | \$3.30 |
| Opportunity cost of profit center S | | 10.10 ^a |
| Transfer price of profit center S | <u>19.00</u> | <u>10.70</u> |
| Total relevant costs | <u>\$22.30</u> | <u>\$24.10</u> |
| Relevant income | <u>\$1.70</u> | <u>\$(0.10)</u> |

^a Computation of opportunity cost of profit center S:

| | |
|------------------------------|--------------------------|
| Market price of component 13 | \$21.60 |
| Relevant costs: | |
| Production | \$9.00 |
| Selling | <u>2.50</u> <u>11.50</u> |
| Relevant income | <u>\$10.10</u> |

The \$19 per unit transfer price signals profit center B to buy inside since component 12 cannot be purchased any cheaper from outside companies. This decision will be in the best interests of profit center B, whose income will increase \$1.70 per unit, but it will not be in the best interests of the company as a whole. If upper-level management forced an outside purchase (which, if it did so, would violate the autonomy criterion), the company as a whole would avoid losing \$0.10 per unit.

In situation 2, as originally assumed, profit center S has sufficient idle capacity to accommodate the needs of profit center B for 20,000 units of component 12. However, now there is the possibility of a reciprocal trading agreement between the Thorn Company and profit center W of the Drake Company wherein the Thorn Company will acquire 20,000 units of subcomponent 121 from profit center W only if profit center B purchases 20,000 units of component 12 from the Thorn Company. Profit center W will be paid \$13 per unit and it costs profit center W only \$2 per unit of variable costs to produce and sell subcomponent 121. Figure 13.2 diagrams the facts in this new situation. The relevant incomes for profit center B and the company are:

management interferes in order to achieve goal congruence, there will be a violation of the autonomy criterion.

In light of the possible absence of an intermediate market and the failure of the outside market price adequately to cope with situations 1 and 2, a *synthetic market price* will now be introduced. The synthetic market price will always send the proper signals to the buying profit center regardless of the facts. It is computed as follows:¹

$$\begin{aligned} \text{Synthetic market price} &= \text{Variable costs of the selling profit center} \\ &\quad + \text{Opportunity cost to the company as a whole} \end{aligned}$$

In order to evaluate the synthetic market price against the four criteria, administer the following three tests: In the first test, return to situation 1—profit center S does not have any idle capacity to accommodate profit center B's need for 20,000 units of component 12—and reset the transfer price equal to the following synthetic market price:

$$\text{Synthetic market price} = \$10.70 + \$10.10 = \$20.80$$

The \$20.80 per unit transfer price signals profit center B to buy the 20,000 units of component 12 from the Thorn Company at \$19 per unit. This decision will be in the best interests of (1) profit center B whose income will increase, as it did in the original version of situation 1, by \$1.70 per unit and (2) the company as a whole, which will now avoid losing the \$0.10 per unit that would have been otherwise lost. All the other three criteria are satisfied as well, especially autonomy, since upper-level management will not have to intercede to avoid the \$0.10 per unit disadvantage to the company as a whole.

In the second test, return to situation 2—a reciprocal trading agreement exists between the Thorn Company and profit center W—and reset the transfer price equal to the following synthetic market price:

$$\text{Synthetic market price} = \$10.70 + \$11.00 = \$21.70$$

The \$21.70 per unit transfer price sends a signal to profit center B to buy 20,000 units of component 12 from the Thorn Company at \$19 per unit. This decision is beneficial to profit center B, as before, to the extent of \$1.70 per unit. However, this time it is also beneficial to the company

¹ A number of terms are used interchangeably in the management accounting literature. The *ideal transfer price* and the *optimum transfer price* are synonymous with *synthetic market price*. The following costs are common substitutes for variable cost in the context of transfer pricing: *escapable*, *avoidable*, *relevant*, *outlay*, and *differential cost*.

as a whole, which will not be disadvantaged to the extent of \$1 per unit. The motivation and performance evaluation criteria are satisfied as well as autonomy since there will be no need for upper-level management to force an internal transfer.

In the third test, return to the fifth illustration—transfer price equal to market price with all four criteria satisfied—and reset the transfer price equal to the following synthetic market price:

$$\text{Synthetic market price} = \$10.70 + \$0 = \$10.70$$

A transfer price of \$10.70 per unit goes all the way back to the very first illustration wherein the transfer price was set equal to variable cost. There the \$10.70 per unit transfer price signaled profit center B to buy the 20,000 units of component 12 from profit center S as opposed to the Thorn Company at \$19 per unit. Goal congruence results because both profit center B and the company as a whole benefit by \$10 per unit if the internal transfer takes place. The synthetic market price, however, fails to satisfy the motivation and performance evaluation criteria for profit center S.

The evaluation of the synthetic market price has now been completed. In conclusion, the synthetic market price will always lead to goal congruence but may lead to motivation and performance evaluation problems for the selling profit center. The latter problem can be easily remedied through the judicious use of a *dual transfer pricing system*, described below.

DUAL TRANSFER PRICING SYSTEM

As has been shown, it is just not possible to have a single transfer price. The buying profit center and the selling profit center have different interests in the transfer price. In one case, the price is used to make a decision to buy and thereby determine the output of the purchasing profit center; and in the other case, the price is an important factor in evaluating the performance of the selling profit center. In a dual-price situation the buying profit center is charged the synthetic market price while the selling profit center is given credit for either standard variable or full cost plus a normal markup. The income for the company as a whole will be less than the total income for the profit centers. In preparing financial statements, intracompany eliminations would have to be made for these differences. Any amount transferred in excess of company costs would have to be eliminated. This dual transfer pricing system has not been in common use, a fact that the authors find surprising, because there is no single transfer pricing method that is capable of satisfying the four criteria in all situations. Only the dual transfer pricing

system is capable of promoting goal congruence, motivation, autonomy, and performance evaluation under all conditions.

INTERNATIONAL TRANSFER PRICING

In their study for the National Association of Accountants, Benke and Edwards asserted that “the advent of U.S.-based multinational corporations and their continued growth have added another, more complicated dimension to transfer pricing.”² In setting an international transfer price, a company will usually concentrate on satisfying a single objective, namely, *minimize income taxation*. The four objectives stressed for domestic transfer pricing—goal congruence, motivation, autonomy, and performance evaluation—are considered secondary.

Let’s illustrate the economic benefit to a company of using a favorable transfer pricing to shift profit from a country with an unfavorable tax structure to one with a favorable tax structure. Product Q is manufactured in the United States where the tax rate merely for the purposes of this illustration is assumed to be 35% and sold in Country X where the tax rate is assumed to be 45%.

In Table 13.2, the transfer price is set equal to \$500 per unit. Clearly, it is economically advantageous to raise the transfer price. In so doing, less of

TABLE 13.2 Profit after Taxes Based on a Transfer Price of \$500 per Unit

| | Manufactured in the United States | Sold in Country X | Company as a Whole |
|---------------------------|--------------------------------------|----------------------|-----------------------|
| Sales price | | \$1,500 | \$1,500 |
| Transfer price | \$500 | (500) | |
| Variable costs | (200) | (150) | (350) |
| Contribution margin | \$300 | \$850 | \$1,150 |
| Number of units | <u>× 10,000</u> | <u>× 10,000</u> | <u>× 10,000</u> |
| Total contribution margin | \$3,000,000 | \$8,500,000 | \$11,500,000 |
| Fixed costs | (1,000,000) | (5,000,000) | (6,000,000) |
| Profit before tax | \$2,000,000 | \$3,500,000 | \$5,500,000 |
| Tax rate | <u>× 0.35</u> | <u>× 0.45</u> | |
| Taxes | \$700,000 | \$1,575,000 | (2,275,000) |
| Profit after tax | | | \$3,225,000 |

² R. L. Benke, Jr., and J. D. Edwards, *Transfer Pricing: Techniques and Uses* (New York: National Association of Accountants, 1980), p. 113.

TABLE 13.3 Profit after Taxes Based on a Transfer Price of \$800 per Unit

| | Manufactured in the United States | Sold in Canada | Company as a Whole |
|---------------------------|--------------------------------------|-------------------|-----------------------|
| Sales price | | \$1,500 | \$1,500 |
| Transfer price | \$800 | (800) | |
| Variable costs | (200) | (150) | (350) |
| Contribution margin | \$600 | \$550 | \$1,150 |
| Number of units | $\times 10,000$ | $\times 10,000$ | $\times 10,000$ |
| Total contribution margin | \$6,000,000 | \$5,500,000 | \$11,500,000 |
| Fixed costs | (1,000,000) | (5,000,000) | (6,000,000) |
| Profit before tax | \$5,000,000 | \$500,000 | \$5,500,000 |
| Tax rate | $\times 0.35$ | $\times 0.45$ | |
| Taxes | <u>\$1,750,000</u> | <u>\$225,000</u> | (1,975,000) |
| Profit after tax | | | \$3,525,000 |

the profit before tax will be shifted into Country X (with its higher tax rate of 45% relative to the lower 35% tax rate in the United States).

In Table 13.3, the transfer price is set equal to \$800 per unit to show how transfer pricing can be a highly potent weapon when used to minimize income taxes. As clearly evident, the transfer price of \$800 per unit (instead of \$500 per unit) has caused a shift of \$3 million of profit before tax from Country X to the United States. The difference in income tax rates, 10% (45% – 35%), times the \$3 million, results in \$300,000 savings in total income taxes (\$2,275,000 – \$1,975,000). By minimizing income taxes through use of transfer pricing, the company increased its total after-tax profit by a corresponding \$300,000 (\$3,525,000 – \$3,225,000).

Tax authorities are concerned about the transfer pricing methods of corporations doing business in their country, recognizing that corporations will seek to maneuver profits by employing a transfer price method to minimize profits in high-tax countries and maximize them in low-tax countries. A 2001 report by the U.S. Senate alleges that multinational corporations evaded up to \$45 billion in U.S. taxes in 2000 by using transfer pricing to manipulate income.³ The same report details one company selling toothbrushes between subsidiaries for \$5,655 each!

To increase the likelihood of corporations paying their fair share in countries where they operate, tax authorities have adopted the Organisation of Economic Co-operation and Development (OECD) guidelines for “arm’s-

³ “A Taxing Battle,” *The Economist*, January 29, 2004.

length price transaction” published in 2001 in the OECD’s “Transfer Pricing Guidelines for Multinational Enterprises and Tax Administrations.”

The OECD guidelines’ acceptable transfer methods fall into two categories: traditional methods and nontraditional methods. Traditional methods for determining the arm’s-length price include: comparable uncontrolled method, cost plus method, and resale price method. The nontraditional methods, referred to as *transactional profits methods*, include the *profit split method* and the *transactional net margin method*.

The *comparable uncontrolled method* is basically the sale price as would exist between unrelated corporations. The *cost plus method* is the transfer price method described earlier in this chapter. The *retail price method* (also referred to as the *resale minus method*) begins with the sale price to an unrelated entity and subtracting an “appropriate” gross margin from that price. The conditions under which the sale would take place between two unrelated entities performing similar activities, employing similar assets to manufacture the product or conduct the service, and exposing the parties to similar business risks are used in establishing the appropriate gross margin.

The two transactional profit methods are regarded as methods of last resort for determining the arm’s-length price. The profit split method, the more commonly used of the two transactional profit methods, is employed when the integration of the parties involved in the transaction who are operating in different countries is so great as to make a separate evaluation of the transfer price extremely difficult. The profit split method divides the profit from the transaction between the two parties based on some reasonable factors for both the parties in the transaction. In turn, an appropriate measure for the factor or factors must be determined that is acceptable to tax authorities. The factor could be the level of contribution made by both entities to the transaction.

The arm’s-length price based on the transactional net margin method, the newest method of the OECD approved methods, is obtained by estimating the net profit margin made from the controlled transaction relative to an appropriate base. Depending on the nature of the transaction, the base could be a financial ratio such as net profit to sales or return on assets employed. This method is becoming more widely used.

Preference for any particular method is not given in the OECD guidelines. Instead, the guidelines indicate that the method that should be employed is the one that most directly and reliably reflects arm’s-length conditions in a particular transaction. National tax authorities, however, may have a preference.

The tax risk that a company faces is that a national tax authority will require the restatement of income under an alternative method, leading to a higher income and additional taxes due plus penalties. For example,

on September 11, 2006, GlaxcoSmithKline announced a settlement with the U.S. Internal Revenue Service (IRS) in which it agreed to pay in excess of \$5 billion in taxes resulting from an assessed income adjustment due to improper transfer pricing. The dispute between the company and the IRS involved Zantac, a highly profitable ulcer drug. The issue was whether it was the research and development undertaken in the U.K. or the advertising and marketing of the product in the United State that made the product valuable. While both were major contributors to the value of Zantac, determining the relative contribution and allocating profits accordingly was not a simple task. The IRS disagreed with the method adopted by GlaxcoSmithKline.

Typically, any noncompliance penalty will be assessed against the taxpayer. The penalty can be substantial. For example, noncompliance penalty in the United States, referred to as an “accuracy-related penalty,” as set forth in Section 482 of the transfer pricing regulations can be either 20% or 40% on the additional tax due. The rules for determining whether the penalty is 20% or 40% are explained in IRC Section 6662. In Canada, Revenue Canada applies a 10% penalty to the adjusted income or loss due to transfer pricing. Canada, unlike the United States, levies a penalty even if there is no change to the tax liability.

There are several ways to minimize tax risk. One way is to provide documentation supporting a particular method in anticipation of a tax audit. The type of documentation that can help in disputes between taxpayers and tax authorities if there is an official request during a transfer pricing tax examination is provided by national tax authorities. For example, Thailand’s Revenue Department provides the following list of items that should be provided:

- Documentation establishing the structure and relationship of a business within the same group, including the business nature of each company.
- Budgets, business plans, and financial projections.
- Documentation establishing the business strategies and the reasons for their adoption.
- Documentation establishing the sales, operating results, and the nature of its dealing with associated enterprises.
- Documentation establishing the reasons for entering into international dealings with associated enterprises.
- Pricing policies, documents relating to product profitability, relevant market information, and profit contributions of each party.
- Documentation establishing the reasons for selection of pricing methodology or methodologies.

- In the case where several pricing methodologies can be adopted, there must be documentation establishing details of other methodologies, and reasons for the rejection of using such methodologies.
- Documentation evidencing the negotiating positions taken with associated enterprises.
- Other documentation that is relevant to the pricing methodologies, if any.

Some national tax authorities will give permission to employ a particular method in advance. These arrangements are useful tax risk management tools. There are two such arrangements: advance pricing agreements and cost contribution arrangements. An *advance pricing agreement (APA)* if available in a country allows a company to determine if the method it uses for determining the transfer is acceptable to the national tax authorities. In the United States, an APA is defined as follows by the IRS:

The Advance Pricing Agreement (APA) Program is designed to resolve actual or potential transfer pricing disputes in a principled, cooperative manner, as an alternative to the traditional adversarial process. An APA is a binding contract between the IRS and a taxpayer by which the IRS agrees not to seek a transfer pricing adjustment under IRC § 482 for a covered transaction if the taxpayer files its tax return for a covered year consistent with the agreed transfer pricing method.⁴

The underlying principles of the APA program are explained in an IRS publication:

The APA Program provides a voluntary process whereby the Internal Revenue Service (“Service”) and taxpayers may resolve transfer pricing issues under §482 of the Internal Revenue Code (“Code”), the Income Tax Regulations (“the regulations”) thereunder, and relevant income tax treaties to which the United States is a party in a principled and cooperative manner on a prospective basis. The APA process increases the efficiency of tax administration by encouraging taxpayers to come forward and present to the Service all the facts relevant to a proper transfer pricing analysis and to work towards a mutual agreement in a spirit of openness and cooperation. The prospective nature of APAs lessens the burden of compliance by giving taxpayers greater certainty regarding their transfer pricing methods, and promotes the principled resolution of these

⁴ <http://www.irs.gov/businesses/corporations/article/0,,id=96277,00.html>.

issues by allowing for their discussion and resolution in advance before the consequences of such resolution are fully known to taxpayers and the Service.⁵

In countries where there is an APA, there is usually a fee. For example, in the United States, the fee is generally \$50,000 and a renewal APA fee is \$35,000.

Another form of preapproval that can be obtained in some countries when the activity involves the development of intangible property such as software by two or more parties is the *cost contribution arrangement*. This type of arrangement, referred to as a *cost sharing arrangement* by the U.S. IRS, is defined as follows:

A cost sharing arrangement is an agreement under which the parties agree to share the costs of development of one or more intangibles in proportion to their shares of reasonably anticipated benefits from their individual exploitation of the interests in the intangibles assigned to them under the arrangement. A taxpayer may claim that a cost sharing arrangement is a qualified cost sharing arrangement only if the agreement meets the requirements of paragraph (b) of this section.⁶

How important is the transfer pricing issue? A 2005 survey by the accounting firm Ernst & Young involving 108 financial institutions from Australia, Canada, Continental Europe, Hong Kong, Japan, Singapore, South Africa, United Kingdom, and the United States concluded that “transfer pricing is rated the most important international tax issue facing multinationals.”⁷ More than half of the participants in the survey indicated that they now set aside a provision for transfer pricing risk in their financial statements.

BOTTOM LINE

- In a decentralized company there will generally be a substantial number of intracompany exchanges of goods and services.

⁵ *Internal Revenue Code § 482: Allocation of income and deductions among taxpayers*, January 9, 2006, p. 2.

⁶ 26 CFR 1.482-7.

⁷ “Transfer Pricing Organisations, Audits and Priorities in the Financial Services Industry” (http://www.ey.com/GLOBAL/content.nsf/New_Zealand/Transfer_Pricing_Overview).

- A transfer price allows the buyer to record the cost of the goods or services received and the seller to record the revenue from the goods or services given up.
- The transfer pricing policy adopted by a company must be carefully monitored to ensure that it is operating as intended.
- The established transfer price must be low enough to meet the needs of the buying responsibility center manager and the company as a whole relative to an external purchase of goods or services.
- There is a danger in having the transfer price so low that the selling responsibility center manager will show losses on intracompany transactions. Such losses will lead to adverse behavioral consequences, poor performance, and a negation of the many benefits of decentralization.
- The established transfer price must also be high enough to motivate the selling responsibility center manager to produce quality goods or render quality service while at the same time controlling costs.
- Four methods are commonly used to arrive at a transfer price: cost, cost plus, negotiated price, and market price.
- Prevailing theory suggests that the most satisfactory transfer price will usually be the competitive market price, if one exists. Unfortunately, in many cases no such market price is readily available.
- The solution to the problem inherent in transfer pricing is predicated on satisfying four criteria—goal congruence, motivation, autonomy, and performance evaluation.
- A dual transfer pricing system is necessary in light of the shortcomings of single transfer pricing systems. For the buyer, a synthetic market price equal to the variable costs of the seller plus opportunity costs to the company as a whole is recommended; and for the seller, standard full cost plus a normal markup.
- For international transfer pricing, the Organisation of Economic Cooperation and Development (OECD) provides approved transfer pricing methods for determining an “arm’s-length price.”
- The OECD guidelines’ acceptable transfer price methods fall into two categories: traditional methods (comparable uncontrolled method, cost plus method, and resale price method), and transactional profits methods (profit split method and the transactional net margin method).
- The tax risk that a company faces in establishing international transfer prices is that a national tax authority will require the restatement of income under an alternative method, leading to a higher income and additional taxes due plus penalties.

PART

Four

Asset Management

Capital Budgeting and Cash Flow Analysis

AGENDA

- Item 1* Explain what capital budgeting is.
- Item 2* Explain the relationship between capital budgeting and owners' wealth.
- Item 3* Identify the capital budgeting process.
- Item 4* Identify the different ways that capital budgeting projects can be classified.
- Item 5* Identify and classify the cash flows associated with an investment project.
- Item 6* Describe and illustrate how to estimate the investment cash flows of an investment project.
- Item 7* Describe and illustrate how to estimate the operating cash flows of an investment project.
- Item 8* Explain how the net cash flow for each period of a project's useful life is estimated.

The value of a particular asset is not always easy to determine. However, CFOs and other financial managers continually face decisions about which assets to invest in. The CFO's objective is to make investment decisions that are consistent with the strategic plan of the company and its objectives, evaluating investment opportunities and selecting those that add value to the company. The challenge is make investments that are sufficient to replace any deteriorating plant and equipment, while at the same time identify value-adding investments—all while keeping within funds available and financing constraints.

The focus of this chapter is on estimating how a company's cash flows are expected to change in the future as a result of an investment decision. As will become apparent, estimating cash flow is an imprecise art at best.

THE INVESTMENT PROBLEM

Companies continually invest funds in assets and these assets produce income and cash flows that the company may then either reinvest in more assets or pay to the owners. These assets represent the company's capital. *Capital* is the company's total assets, including both tangible and intangible assets. These assets include physical assets (such as land, buildings, equipment, and machinery), as well as assets that represent property rights (such as accounts receivable, securities, patents, copyrights). When we refer to *capital investment*, we are referring to the company's investment in its assets.¹

The company's capital investment decision may be comprised of a number of distinct decisions, each referred to as a *project*. A capital project is a set of assets that are contingent on one another and are considered together. For example, suppose a company is considering the production of a new product. This capital project requires the company to acquire land, build facilities, and purchase production equipment. And this project may also require the company to increase its investment in its working capital—inventory, cash, or accounts receivable. *Working capital* is the collection of assets needed for day-to-day operations that support a company's long-term investments.

The investment decisions of the company are decisions concerning a company's capital investment. When we refer to a particular decision that financial managers must make, we are referring to a decision pertaining to a capital project.

Investment Decisions and Owners' Wealth Maximization

CFOs must evaluate a number of factors in making investment decisions. Not only does the CFO need to estimate how much the company's future cash flows will change if it invests in a project, but the CFO must also evaluate the uncertainty associated with these future cash flows.

We already know that the value of the company today is the present value of all its future cash flows. But we need to understand better where these future cash flows come from. They come from assets that are already in place, which are the assets accumulated as a result of all past investment

¹ The term *capital* also has come to mean the funds used to finance the company's assets and in some contexts refers to the sum of equity and interest-bearing debt. In this sense, capital consists of notes, bonds, stock, and short-term financing. The term *capital structure* refers to the mix of these different sources of capital used to finance a company's assets.

decisions, and future investment opportunities. The value of the company is, therefore,

$$\text{Value of the company} = \frac{\text{Present value of cash flows of assets in place}}{\text{flows of assets in place}} + \frac{\text{Present value of all future cash flows}}{\text{all future cash flows}}$$

Future cash flows are discounted at a rate that represents investors' assessments of the uncertainty that these cash flows will flow in the amounts and when expected.

The assessment of the uncertainty of the cash flows requires evaluating their risk—the *cash flow risk*. Cash flow risk comes from two basic sources:

1. *Sales risk*, which is the degree of uncertainty related to the number of units that will be sold and the price of the good or service.
2. *Operating risk*, which is the degree of uncertainty concerning operating cash flows that arises from the particular mix of fixed and variable operating costs.

Sales risk is related to the economy and the market in which the company's goods and services are sold. Operating risk, for the most part, is determined by the product or service that the company provides and is related to the sensitivity of operating cash flows to changes in sales. We refer to the combination of these two risks as *business risk*.

A project's business risk is reflected in the discount rate, which is the rate of return required to compensate the suppliers of capital (that is, creditors and owners) for the amount of risk they bear. From the perspective of investors, the discount rate is the *required rate of return (RRR)*. From the company's perspective, the discount rate is the *cost of capital*—what it costs the company to raise a dollar of new capital.

For example, suppose a company invests in a new project. How does the investment affect the company's value? If the project generates cash flows that just compensate the suppliers of capital for the risk they bear on this project (that is, it earns the cost of capital), the value of the company does not change. If the project generates cash flows greater than needed to compensate them for the risk they take on, it earns more than the cost of capital, increasing the value of the company. If the project generates cash flows less than needed to compensate investors, it earns less than the cost of capital, decreasing the value of the company.

How do we know whether the cash flows are more than or less than needed to compensate for the risk? If we discount all the cash flows at the cost of capital, we can assess how this project affects the present value of the company. If the expected change in the value of the company from an

investment is positive, the project returns more than the cost of capital; if the expected change is negative, the project returns less than the cost of capital.

Capital budgeting is the process of identifying and selecting investments in long-lived assets, or assets expected to produce benefits over more than one year. In Chapter 15, we discuss how to evaluate cash flows in deciding whether to invest. We cover how to determine cash flow risk and factor this risk into capital budgeting decisions in Chapter 16.

CAPITAL BUDGETING

Because a company must continually evaluate possible investments, capital budgeting is an ongoing process. However, before a company begins thinking about capital budgeting, it must first determine its corporate strategy—its broad set of objectives for future investment. How does a company achieve its corporate strategy? By making investments in long-lived assets that add value. Selecting these projects is what capital budgeting is all about.

There are five stages in the capital budgeting process, as illustrated in Figure 14.1. Though this may not be an accurate depiction of all companies' process, this provides a general idea of the process that many companies experience.

Classifying Investment Projects

Classifying projects is useful because the analysis of a project may depend on the type of project. One way of classifying projects is by project life, whether short-term or long-term. We do this because in the case of long-term projects, the time value of money plays an important role in long-term projects. Another way of classifying projects is by their risk. The riskier the project's future cash flows, the greater the role of the cost of capital in decision making. Still another way of classifying projects is by their dependence on other projects. The relationship between a project's cash flows and the cash flows of some other project of the company must be incorporated explicitly into the analysis since we want to analyze how a project affects the total cash flows of the company.

Classification According to Economic Life

An investment generally provides benefits over a limited period of time, referred to as its economic life. The economic life or useful life of an asset is determined by physical deterioration, obsolescence, or the degree of competition in the market for a product.

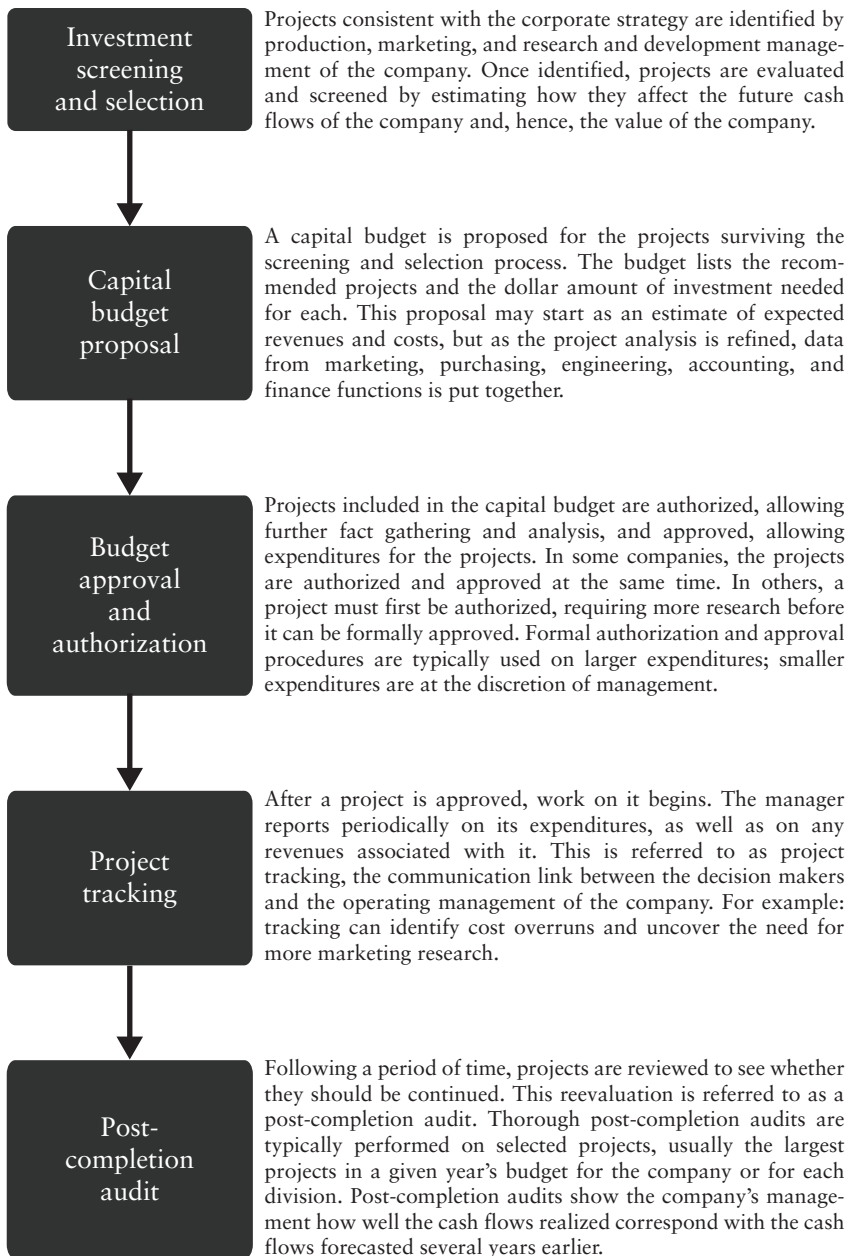
FIGURE 14.1 The Capital Budgeting Process

The *economic life* is an estimate of the length of time that the asset will provide benefits to the company. After its useful life, the revenues generated by the asset tend to decline rapidly and its expenses tend to increase.

Typically, an investment requires an immediate expenditure and provides benefits in the form of cash flows received in the future. If benefits are received only within the current period—within one year of making the investment—we refer to the investment as a short-term investment. If these benefits are received beyond the current period, we refer to the investment as a long-term investment and refer to the expenditure as a capital expenditure. An investment project may comprise one or more capital expenditures. For example, a new product may require investment in production equipment, a building, and transportation equipment.

Short-term investment decisions involve, primarily, investments in current assets: cash, marketable securities, accounts receivable, and inventory. The objective of investing in short-term assets is the same as long-term assets: maximizing owners' wealth. Nevertheless, we consider them separately for two practical reasons:

1. Decisions about long-term assets are based on projections of cash flows far into the future, requiring focus on the time value of money.
2. Long-term assets do not figure into the daily operating needs of the company.

Decisions regarding short-term investments, or current assets, are concerned with day-to-day operations.

Classification According to Risk

Suppose you are faced with two investments, A and B, each promising a \$100 cash inflow 10 years from today. If A is riskier than B, what are they worth to you today? If you do not like risk, you would consider A less valuable than B because the chance of getting the \$100 in 10 years is less for A than for B. Therefore, valuing a project requires considering the risk associated with its future cash flows.

The investment's risk of return can be classified according to the nature of the project represented by the investment:

- *Replacement projects* are investments in the replacement of existing equipment or facilities.
- *Expansion projects* are investments in projects that broaden existing product lines and existing markets.

- *New products and markets* are projects that involve introducing a new product or entering into a new market.
- *Mandated projects* are projects required by government laws or agency rules.

Replacement projects include the maintenance of existing assets to continue the current level of operating activity. Projects that reduce costs, such as replacing old equipment or improving efficiency, are also considered replacement projects. To evaluate replacement projects we need to compare the value of the company with the replacement asset to the value of the company without that same replacement asset. What we're really doing in this comparison is looking at opportunity costs: what cash flows would have been if the company had stayed with the old asset.

There's little risk in the cash flows from replacement projects. The company is simply replacing equipment or buildings already operating and producing cash flows. And the company typically has experience in managing similar new equipment.

Expansion projects, which are intended to enlarge a company's established product or market, also involve little risk. However, investment projects that involve introducing new products or entering into new markets are riskier because the company has little or no management experience in the new product or market.

A company is forced or coerced into its mandated projects. These are government-mandated projects typically found in heavy industries, such as utilities, transportation, and chemicals, all industries requiring a large portion of their assets in production activities. Government agencies, such as the Occupational Health and Safety Agency (OSHA) or the Environmental Protection Agency (EPA), may impose requirements that companies install specific equipment or alter their activities (such as how they dispose of waste).

We can further classify mandated projects into two types: contingent and retroactive. Suppose, as a steel manufacturer, we are required by law to include pollution control devices on all smoke stacks. If we are considering a new plant, this mandated equipment is really part of our new plant investment decision—the investment in pollution control equipment is contingent on our building the new plant.

On the other hand, if we are required by law to place pollution control devices on existing smoke stacks, the law is retroactive. We do not have a choice. We must invest in the equipment whether it increases the value of the company or not. In this case, we either select from among possible equipment that satisfies the mandate, or we weigh the decision whether to halt production in the offending plant.

Classification According to Dependence on Other Projects

In addition to considering the future cash flows generated by project, a company must consider how it affects the assets already in place—the results of previous project decisions—as well as other projects that may be undertaken. Projects can be classified as follows according to the degree of dependence with other projects: independent projects, mutually exclusive projects, contingent projects, and complementary projects.

An *independent project* is one whose cash flows are not related to the cash flows of any other project. In other words, accepting or rejecting an independent project does not affect the acceptance or rejection of other projects. An independent project can be evaluated strictly on the effect it will have on the value of a company without having to consider how it affects the company's other investment opportunities, and vice versa.

Projects are *mutually exclusive* if the acceptance of one precludes the acceptance of other projects. There are some situations where it is technically impossible to take on more than one project. For example, suppose a manufacturer is considering whether to replace its production facilities with more modern equipment. The company may solicit bids among the different manufacturers of this equipment. The decision consists of comparing two choices:

1. Keeping its existing production facilities.
2. Replacing the facilities with the modern equipment of one manufacturer.

Because the company cannot use more than one production facility, it must evaluate each bid and determine the most attractive one. The alternative production facilities are mutually exclusive projects: The company can accept only one bid. The alternatives of keeping existing facilities or replacing them are also mutually exclusive projects. The company cannot keep the existing facilities *and* replace them.

Contingent projects are dependent on the acceptance of another project. Suppose a greeting card company develops a new character, Joe Cool, and is considering starting a line of Joe Cool cards. If Joe catches on, the company will consider producing a line of Joe Cool office supplies—but only if the Joe Cool character becomes popular. The office supply project is a contingent project. It is contingent on (1) the company taking on the Joe Cool project and (2) Joe Cool's success.

Another form of dependence is when there are *complementary projects*. Projects are complementary projects if the investment in one enhances the cash flows of one or more other projects. Consider a manufacturer of per-

sonal computer equipment and software. If it develops new software that enhances the abilities of a computer mouse, the introduction of this new software may enhance its mouse sales as well.

CASH FLOW FROM INVESTMENTS

Incremental Cash Flows

A company invests only to make its owners better off, meaning increasing the value of their ownership interest. A company will have cash flows in the future from its past investment decisions. When it invests in new assets, it expects the future cash flows to be greater than without this new investment. Otherwise it doesn't make sense to make this investment. The difference between the cash flows of the company with the investment project and the cash flows of the company without the investment project—both over the same period of time—is referred to as the *project's incremental cash flows*.

We have to look at how it will change the future cash flows of the company to evaluate an investment. How much does the value of the company change as a result of the investment? The change in a company's value as a result of a new investment is the difference between its benefits and its costs:

$$\begin{aligned} & \text{Project's change in the value of the company} \\ & = \text{Project's benefits} - \text{Project's costs} \end{aligned}$$

A more useful way of evaluating the change in the value of the company is to break down the project's cash flows into two components:

1. The present value of the cash flows from the project's operating activities (revenues and operating expenses), referred to as the *project's operating cash flows (OCF)*.
2. The present value of the *investment cash flows*, which are the expenditures needed to acquire the project's assets and any cash flows from disposing of the project's assets.

This can be expressed as:

$$\begin{array}{rcl} \text{Change in the} & & \text{Present value of the change} & & \text{Present value} \\ \text{value of the} & = & \text{in operating cash flows} & + & \text{of investment} \\ \text{company} & & \text{provided by the project} & & \text{cash flows} \end{array}$$

The present value of a project's operating cash flows is typically positive (indicating predominantly cash inflows) and the present value of the investment cash flows is typically negative (indicating predominantly cash outflows).

Investment Cash Flows

Investment cash flows takes into account asset acquisition costs and disposal costs.

Asset Acquisition

The analysis of an investment must consider all the cash flows associated with acquiring and disposing of assets. In any project, there are a number of different types of investment cash flows to consider, including the cost of acquisition (e.g., cost of the asset, setup expenditures, including shipping and installation, and any tax credit).²

Suppose the company buys equipment that costs \$100 million and it costs \$1 million to install it. If the company is eligible for a 7% tax credit on this equipment (that is, 7% of the total cost of buying and installing the equipment), the change in the company's cash flow from acquiring the asset is \$93.93 million:

$$\begin{aligned} \text{Cash outflow from acquiring assets, in millions} &= \$100 + \$1 - 0.07 (\$101) \\ &= \$93.93 \text{ million} \end{aligned}$$

What about expenditures made in the past for assets or research that would be used in the project we're evaluating? Suppose the company spent \$1 million over the past three years developing a new type of toothpaste. Should the company consider this \$1 million spent on research and development when deciding whether to produce this new project we are considering? No: These expenditures have already been made and do not affect how the new product changes the future cash flows of the company. This \$1 million is a *sunk cost* and it is not considered in the analysis of the new project. Whether or not the company goes ahead with this new product, this \$1 million has been spent. A sunk cost is any cost that has already been incurred that does not affect future cash flows of the company.

Consider another example. Suppose the company owns a building that is currently empty. If the company suddenly has an opportunity to use it for the production of a new product, is the cost of the building relevant to the

² The tax credit may be an investment tax credit or a special credit—such as a credit for a pollution control device—depending on the prevailing tax law. For a discussion of tax credits, see Chapter 7.

new product decision? The cost of the building itself is a sunk cost because it was an expenditure made as part of some previous investment decision. The cost of the building does not affect the decision to go ahead with the new product.

Suppose the company was using the building in some way producing cash (say, renting it or selling it) and the new project is going to take over the entire building. The cash flows given up represent opportunity costs that must be included in the analysis of the new project. In the case of a company that could rent the building, these forgone cash flows are not asset acquisition cash flows, but rather must be considered part of the project's future operating cash flows.

Further, if the company incurs costs in renovating the building to manufacture the new product, the renovation costs are relevant and should be included in our asset acquisition cash flows.

Asset Disposition

At the end of the useful life of an asset, the company may be able to sell the asset or may have to pay another party to haul it away or close it down. If the company is making a decision that involves replacing an existing asset, the cash flow from disposing of the old asset must be considered because it is a cash flow relevant to the acquisition of the new asset.

If the company disposes of an asset, whether at the end of its useful life or when it is replaced, two types of cash flows must be considered: what the company expects to receive or expects to pay in disposing of the asset and any tax consequences resulting from the disposal. The proceeds are what the company expects to sell the asset for if sold. If the company must pay for the disposal of the asset, this cost is a cash outflow.

$$\text{Cash flow from disposing assets} = \text{Proceeds or payment from disposing assets} - \text{Taxes from disposing assets}$$

Consider the investment in a gas station. The current owner wants to sell the station to another gas station proprietor. But if a buyer cannot be found and the station is abandoned, the current owner may be required to remove the underground gasoline storage tanks to prevent environmental damage. Thus, a cost is incurred at the end of the asset's life.

The tax consequences are a bit more complicated. Taxes depend on: (1) the expected sales price, (2) the carrying value of the asset for tax purposes (called the *tax basis*) at the time of disposition, and (3) the tax rate at the time of disposal.

If a company sells the asset for more than its tax basis but less than its original cost, the difference between the sales price and the tax basis is a gain, taxable at ordinary tax rates. If a company sells the asset for more than its original cost, then the gain is broken into two parts: the capital gain (the difference between the sales price and the original cost) and recapture of depreciation (the difference between the original cost and the tax basis).

The *capital gain* is the benefit from the appreciation in the value of the asset and may be taxed at special rates, depending on the tax law at the time of sale. The *recapture of depreciation* represents the amount by which the company has overdepreciated the asset during its life. This means that more depreciation has been deducted from income (hence reducing taxes) than necessary to reflect the actual depreciation of the asset. The recapture portion is taxed at the ordinary tax rates, because this excess depreciation taken all these years has reduced taxable income.

If a company sells an asset for less than its tax basis, the result is a *capital loss*. In this case, the asset's value has decreased by more than the amount taken for depreciation for tax purposes. A capital loss is given special tax treatment:

- If there are capital gains in the same tax year as the capital loss, the gains and losses are combined, so that the capital loss reduces the taxes paid on capital gains.
- If there are not sufficient capital gains to offset against the capital loss, the remaining capital loss is used to reduce ordinary taxable income.

As discussed in Chapter 7, the benefit from a loss on the sale of an asset is the amount by which taxes are reduced. The reduction in taxable income is referred to as a *tax shield* because the loss shields some income from taxation. For example if a company has a loss of \$1,000 on the sale of an asset and has a tax rate of 40%, this means that its taxable income is \$1,000 less and its tax liability is \$400 less than it would have been without the sale of the asset.

Suppose a company is evaluating an asset that costs \$10,000 that it expects to sell in five years. Suppose further that the tax basis of the asset for tax purposes will be \$3,000 after five years and that the company's tax rate is 40%. What are the expected cash flows from disposing of this asset?

If the company expects to sell the asset for \$8,000 in five years, $\$10,000 - \$3,000 = \$7,000$ of the asset's cost will be depreciated; yet the asset lost only $\$10,000 - \$8,000 = \$2,000$ in value. Therefore, the company has overdepreciated the asset by \$5,000. Because this overdepreciation represents deductions to be taken on the company's tax returns over the five years that don't reflect the actual depreciation in value (the asset doesn't lose \$7,000

in value, only \$2,000), this \$5,000 is taxed at ordinary tax rates. If the company's tax rate is 40%, the tax will be $40\% \times \$5,000 = \$2,000$.

The cash flow from disposition is the sum of the direct cash flow (someone pays us for the asset or the company pays someone to dispose of it) and the tax consequences. In this example, the cash flow is the \$8,000 we expect someone to pay the company for the asset, less the \$2,000 in taxes we expect the company to pay, or \$6,000 cash inflow. Suppose instead that the company expects to sell this asset in five years for \$12,000. Again, the asset is overdepreciated by \$7,000. In fact, the asset is not expected to depreciate, but rather appreciate over the five years. The \$7,000 in depreciation is recaptured after five years and taxed at ordinary rates: 40% of \$7,000, or \$2,800. The \$2,000 capital gain is the appreciation in the value of the asset and may be taxed at special rates. If the tax rate on capital gain income is assumed to be 30%, the company would expect to pay 30% of \$2,000, or \$600 in taxes on this gain. Selling the asset in five years for \$12,000 therefore results in an expected cash inflow of $\$12,000 - \$2,800 - \$600 = \$8,600$.

Suppose the company expects to sell the asset in five years for \$1,000. If the company can reduce its ordinary taxable income by the amount of the capital loss, $\$3,000 - \$1,000 = \$2,000$, its tax liability will be 40% of \$2,000, or \$800 because of this loss. As mentioned earlier, this reduction in the taxes is a tax shield, since the loss "shields" \$2,000 of income from taxes. Combining the \$800 tax reduction with the cash flow from selling the asset, the \$1,000, gives the company a cash inflow of \$1,800.

The calculation of the cash flow from disposition for the alternative sales prices of \$8,000, \$12,000, and \$1,000 are shown in Appendix 14.A.

Disposition of New Investment Consider the investment in a gas station. The current owner may want to leave the business (retire, whatever), selling the station to another gas station proprietor. But if a buyer cannot be found because of lack of gas buyers in the area, the current owner may be required to remove the underground gasoline storage tanks to prevent environmental damage. Thus, a cost is incurred at the end of the asset's life.

The tax consequences are a bit more complicated. Taxes depend on the expected sales price and the tax basis at the time of disposition. If a company sells the asset for more than its tax basis but less than its original cost, the difference between the sales price and the tax basis is a gain, taxable at ordinary tax rates.

If a company sells the asset for more than its original cost, then the gain is broken into two parts: a capital gain, which is the difference between the sales price and the original cost; and recapture depreciation, which is the difference between the original cost and the tax basis. The capital gain is

the benefit from the appreciation in the value of the asset and may be taxed at special rates, depending on the tax law at the time of sale. The recapture portion is taxed at the ordinary tax rates, since this excess depreciation taken all these years has reduced taxable income.

If a company sells an asset for less than its tax basis, the result is a capital loss. In this case, the asset's value has decreased by more than the amount taken for depreciation for tax purposes. A capital loss is given special tax treatment as discussed earlier. The benefit from a loss on the sale of an asset is the amount by which taxes are reduced (i.e., the tax shield). If the company has a loss of \$1,000 on the sale of an asset and has a tax rate of 40%, this means that its taxable income is \$1,000 less and its taxes are \$400 less than they would have been without the sale of the asset.

The relevant book value of an asset in the case of determining the tax gain or loss—and hence the related cash flow—is the tax basis of the asset. The tax basis is the difference between the original cost of the asset and any accumulated depreciation, where this accumulated depreciation is the prescribed depreciation according to the tax code.

Consider an asset purchased at the beginning of 20X1 for \$1 million. If this is a 3-year MACRS asset, its depreciation, accumulated depreciation, and tax basis each year is the following:³

| Year | MACRS Rate | Depreciation | Accumulated Depreciation | Tax Basis at End of Year |
|------|------------|--------------|--------------------------|--------------------------|
| 20X1 | 33.33% | \$333,300 | \$333,300 | \$666,700 |
| 20X2 | 44.51 | 444,500 | 777,800 | 222,200 |
| 20X3 | 14.81 | 148,100 | 925,900 | 74,100 |
| 20X4 | 7.41 | 74,100 | 1,000,000 | 0 |

Whether there is a gain or a loss on the sale of this asset depends on whether the sales price is above the tax basis (hence, a gain), or below the tax basis (hence, a loss). If the sales price is above the original cost of \$1 million, the total gain is broken into two parts—that which is above the original cost (sales price – original cost), which is taxed at capital gains rates, and that which is below (original cost – tax basis), which is taxed at ordinary rates.

What is the gain or loss if the asset described above is sold:

| | |
|---|--|
| at the end of 20X2, for \$250,000? Gain = \$250,000 – \$222,200 = \$27,800 | This gain is taxed at ordinary rates because the sales price of \$250,000 is less than original cost of \$1 million. |
|---|--|

³ MACRS depreciation rates are the rates prescribed by the U.S. Internal Revenue Code for depreciation for tax purposes. These rates are provided in Chapter 7.

| | |
|--|--|
| at the end of 20X3, for \$50,000? Loss = $\$50,000 - \$74,100 = -\$24,100$ | This is a capital loss because it is sold at less than the tax basis at the time of the sale. |
| at the end of 20X4, for \$1,100,000? Gain = $\$1,100,000 - \$666,700 = \$433,300$ | The gain is taxed in two parts: <ul style="list-style-type: none"> ■ \$100,000 taxed as a capital gain ■ \$333,300 taxed at ordinary rates |

Disposition of Existing Asset(s) Let's also not forget about disposing of any existing assets. Suppose the company bought equipment 10 years ago and at that time expected to be able to sell it 15 years later for \$10,000. If the company decides today to replace this equipment, it must consider what it is giving up by not disposing of an asset as planned.

- If the company does not replace the equipment today, it would continue to depreciate it for five more years and then sell it for \$10,000.
- If the company replaces the equipment today, it would not have five more years' depreciation on the replaced equipment and it would not have \$10,000 in five years (but perhaps some other amount today).

This \$10,000 in five years, less any taxes, is a forgone cash flow that we must figure into the investment cash flows. Also, the depreciation the company *would have had* on the replaced asset must be considered in analyzing the replacement asset's operating cash flows. So, any time that a company is making a decision pertaining to replacing an asset, the forgone depreciation must be accounted for.

Operating Cash Flows

In the simplest form of investment, there will be a cash outflow when the asset is acquired and there may be either a cash inflow or an outflow at the end of its economic life. In most cases these are not the only cash flows—the investment may result in changes in revenues, expenditures, taxes, and working capital. These are operating cash flows since they result directly from the operating activities—the day-to-day activities of the company.

What we are after here are estimates of operating cash flows. We cannot know for certain what these cash flows will be in the future, but we must attempt to estimate them. What is the basis for these estimates? We base them on marketing research, engineering analyses, operations, analysis of our competitors—and our managerial experience.

Change in Revenues

Suppose we are a food processor considering a new investment in a line of frozen dinner products. If we introduce a new ready-to-eat dinner product that is not frozen, our marketing research will indicate how much we should expect to sell. But where do these new product sales come from? Some may come from consumers who do not already buy frozen dinner products. But some of the not-frozen dinner product sales may come from consumers who choose to buy the not-frozen dinner product instead of frozen dinners. It would be nice if these consumers are giving up buying our competitors' frozen dinners. Yet some of them may be giving up buying our frozen dinners. So, when we introduce a new product, we are really interested in how it *changes the revenues* of the entire company (that is, the incremental revenues), rather than the sales of the new product alone.

We also need to consider any forgone revenues—opportunity costs—related to our investment. Suppose our company owns a building currently being rented to another company. If we are considering terminating that rental agreement so we can use the building for a new project, we need to consider the forgone rent—what we would have earned from the building. Therefore, the revenues from the new project are really only the additional revenues—the revenues from the new project minus the revenue we could have earned from renting the building.

Thus, when a company undertakes a new project, the financial managers want to know how it changes the company's total revenues, not merely the new product's revenues.

Change in Expenses

When a company takes on a new project, all the costs associated with it will change the company's expenses. If the investment involves changing the sales of an existing product, we need to estimate the change in unit sales. Once we have an estimate in how sales may change, we can develop an estimate of the additional costs of producing the additional number of units by consulting with production management. And, we will want an estimate of how the product's inventory may change when production and sales of the product change.

If the investment involves changes in the costs of production, we compare the costs without this investment with the costs with this investment. For example, if the investment is the replacement of an assembly line machine with a more efficient machine, we need to estimate the change in the company's overall production costs such as electricity, labor, materials, and management costs.

A new investment may change not only production costs but also operating costs, such as rental payments and administration costs. Changes in operating costs as a result of a new investment must be considered as part of the changes in the company's expenses. Increasing cash expenses are cash outflows, and decreasing cash expenses are cash inflows.

Change in Taxes

Taxes figure into the operating cash flows in two ways. First, if revenues and expenses change, taxable income and, therefore, taxes change. That means we need to estimate the change in taxable income resulting from the changes in revenues and expenses resulting from a new project to determine the effect of taxes on the company. Second, the deduction for depreciation reduces taxes. Depreciation itself is not a cash flow. But depreciation reduces the taxes that must be paid, shielding income from taxation. The tax shield from depreciation is like a cash inflow.

Suppose a company is considering a new product that is expected to generate additional sales of \$200,000 and increase expenses by \$150,000. If the company's tax rate is 40%, considering only the change in sales and expenses, taxes go up by $\$50,000 \times 40\%$ or \$20,000. This means that the company is expected to pay \$20,000 more in taxes because of the increase in revenues and expenses.

Let's change this around and consider that the product will generate \$200,000 in revenues and \$250,000 in expenses. Considering only the change in revenues and expenses, if the tax rate is 40%, taxes go down by $\$50,000 \times 40\%$, or \$20,000. This means that we reduce our taxes by \$20,000, which is like having a cash inflow of \$20,000 from taxes. Now, consider depreciation. When a company buys an asset that produces income, the tax laws allow it to depreciate the asset, reducing taxable income by a specified percentage of the asset's cost each year. By reducing taxable income, the company is reducing its taxes. The reduction in taxes is like a cash inflow since it reduces the company's cash outflow to the government.

Suppose a company has taxable income of \$50,000 before depreciation and a flat tax rate of 40%. If the company is allowed to deduct depreciation of \$10,000, how has this changed the taxes it pays?

| | Without Depreciation | With Depreciation |
|----------------|----------------------|-------------------|
| Taxable income | \$50,000 | \$40,000 |
| Tax rate | <u>0.40</u> | <u>0.40</u> |
| Taxes | \$20,000 | \$16,000 |

Depreciation reduces the company's tax-related cash outflow by \$20,000 – \$16,000 = \$4,000 or, equivalently, by $\$10,000 \times 40\% = \$4,000$. The effect depreciation has on taxes is the depreciation tax shield.

Consider another depreciation example, this time involving replacing an existing asset with another, which affects both depreciation and the cash flow associated with the depreciation tax shield. Suppose the machine being replaced was bought at the beginning of 20X1 for \$75,000. This asset has been depreciated as a 5-year asset using MACRS. If the machine is replaced at the beginning of 20X4 with a new machine that costs \$50,000 and is also a 5-year asset, how does the change in depreciation affect the cash flows if the company's tax rate is 30%? We can calculate the effect two ways:

1. Calculate the change in depreciation and calculate the tax shield related to the change in depreciation. The change in depreciation is $\$10,000 - \$8,640 = \$1,360$.⁴ The change in the depreciation tax shield is 30% of \$1,360, or \$408.
2. Compare the depreciation and related tax shield from the old and the new machines. For example, the depreciation tax shield on the old machine for 20X4 would have been $\$8,640 \times 30\% = \$2,592$, whereas the depreciation tax shield on the new machine is $\$10,000 \times 30\% = \$3,000$. Therefore, the change in the cash flow from depreciation is $\$3,000 - \$2,592 = \$408$.

Analysis of a capital investment decision requires a focus on incremental cash flows. Therefore, the difference in the depreciation and the tax shield from depreciation must be considered in the operating cash flows rather than simply the depreciation and depreciation tax shield associated with the new asset. For this replacement decision, the differences in the depreciation and depreciation tax shields are as follows:

| Year | Depreciation on the Asset Being Replaced | Depreciation on the New Asset | Difference in Depreciation | Difference in the Depreciation Tax Shield |
|------|--|-------------------------------|----------------------------|---|
| 20X4 | \$8,640 | \$10,000 | \$1,360 | \$408.0 |
| 20X5 | 8,640 | 16,000 | 7,360 | 2,208.0 |
| 20X6 | 4,320 | 9,600 | 5,280 | 1,584.0 |
| 20X7 | 0 | 5,760 | 5,760 | 1,728.0 |
| 20X8 | 0 | 5,760 | 5,760 | 1,728.0 |
| 20X9 | 0 | 2,880 | 2,880 | 864.0 |

⁴ The machine purchased in 20X1 is now in its fourth year in 20X4, with depreciation of $11.52\% \times \$75,000 = \$8,640$.

Change in Working Capital

Working capital consists of short-term assets, also referred to as current assets, which support the day-to-day operating activity of the business. Net working capital is the difference between current assets and current liabilities. Net working capital is what would be left over if the company had to pay off its current obligations using its current assets. The adjustment we make for changes in net working capital is attributable to two sources:

1. A change in current asset accounts for transactions or precautionary needs.
2. The use of the accrual method of accounting.

An investment may increase the company's level of operations, resulting in an increase in the net working capital needed (also considered transactions needs). If the investment is to produce a new product, the company may have to invest more in inventory (raw materials, work-in-process, and finished goods). If to increase sales means extending more credit, then the company's accounts receivable will increase. If the investment requires maintaining a higher cash balance to handle the increased level of transactions, the company will need more cash. If the investment makes the company's production facilities more efficient, it may be able to reduce the level of inventory.

Because of an increase in the level of transactions, the company may want to keep more cash and inventory on hand for precautionary purposes. That is because as the level of operations increases, the effect of any fluctuations in demand for goods and services may increase, requiring the company to keep additional cash and inventory "just in case." The company may increase working capital as a precaution because if there is greater variability of cash and inventory, a greater safety cushion will be needed. On the other hand, if a project enables the company to be more efficient or lowers costs, it may lower its investment in cash, marketable securities, or inventory, releasing funds for investment elsewhere in the company.

We also use the change in working capital to adjust accounting income (revenues less expenses) to a cash basis because cash flow is ultimately what we are valuing, not accounting numbers. But since we generally have only the accounting numbers to work from, we use this information, making adjustments to arrive at cash.

To see how this works, let's look at the cash flow from sales. Not every dollar of sales is collected in the year of sale. Customers may pay some time after the sale. Using information from the accounts receivable department about how payments are collected, we can determine the change in the cash flows from revenues. Suppose we expect sales in the first year to

increase by \$20,000 per month and it typically takes customers 30 days to pay. The change in cash flows from sales in the first year is $\$20,000 \times 11 = \$220,000$ —not $\$20,000 \times 12 = \$240,000$. The way we adjust for this difference between what is sold and what is collected in cash is to keep track of the change in working capital, which is the change in accounts receivable in this case. An increase in working capital is used to adjust revenues downward to calculate cash flow:

| | |
|--------------------------------------|---------------|
| Change in revenues | \$240,000 |
| Less increase in accounts receivable | <u>20,000</u> |
| Change in cash inflow from sales | \$220,000 |

On the other side of the balance sheet, if the company is increasing its purchases of raw materials and incurring more production costs, such as labor, the company may increase its level of short-term liabilities, such as accounts payable and salary and wages payable.

Suppose expenses for materials and supplies are forecasted at \$10,000 per month for the first year and it takes the company 30 days to pay. Expenses for the first year are $\$10,000 \times 12 = \$120,000$, yet cash outflow for these expenses is only $\$10,000 \times 11 = \$110,000$ since the company does not pay the last month's expenses until the following year. Accounts payable increases by \$10,000, representing one month's expenses. The increase in net working capital (increase in accounts payable \rightarrow increases current liabilities \rightarrow increases net working capital) reduces the cost of goods sold to give us the cash outflow from expenses:

| | |
|------------------------------------|---------------|
| Cost of goods sold | \$120,000 |
| Less: increase in accounts payable | <u>10,000</u> |
| Change in cash flow from expenses | \$110,000 |

A new project may result in either an increase in net working capital, a decrease in net working capital, or no change in net working capital.

Further, working capital may change at the beginning of the project and at any point during the life of the project. For example, as a new product is introduced, sales may be terrific in the first few years, requiring an increase in cash, accounts receivable, and inventory to support these increased sales. But all of this requires an increase in working capital—a cash outflow.

But later sales may fall off as competitors enter the market. As sales and production fall off, the need for the increased cash, accounts receivable, and inventory falls off also. As cash, accounts receivable, and inventory are reduced, there is a cash inflow in the form of the reduction in the funds that become available for other uses within the company.

A change in net working capital can be thought of specifically as part of the initial investment—the amount necessary to get the project going. Or it can be considered generally as part of operating activity—the day-to-day business of the company. So where do we classify the cash flow associated with net working capital? With the asset acquisition and disposition represented in the new project or with the operating cash flows?

Classifying Working Capital Changes In many applications, we can arbitrarily classify the change in working capital as either investment cash flows or operating cash flows. And the classification doesn't really matter since it is the bottom line, the net cash flows, that matters. How we classify the change in working capital does not affect a project's attractiveness. However, we will take care in our examples to classify the change in working capital according to whether it is related to operating or investment cash flows so you can see how to make the appropriate adjustments.

Putting It All Together

Here is what we need to put together to calculate the change in the company's operating cash flows related to a new investment we are considering:

- Changes in revenues and expenses.
- Cash flow from changes in taxes from changes in revenues and expenses.
- Cash flow from changes in cash flows from depreciation tax shields.
- Changes in net working capital.

There are many ways of compiling the component cash flow changes to arrive at the change in operating cash flow. We will start by first calculating taxable income, making adjustments for changes in taxes, noncash expenses, and net working capital to arrive at operating cash flow.

Suppose a company is evaluating a project that is expected to increase sales by \$200,000 and expenses by \$150,000. Accounts receivable are expected to increase by \$20,000 and accounts payable are expected to increase by \$5,000, but no changes in cash or inventory are expected. Further, suppose the project's assets will have a \$10,000 depreciation expense for tax purposes. If the tax rate is 40%, what is the operating cash flow from this project?

| | |
|----------------------------------|---------------|
| Change in sales | \$200,000 |
| Less change in expenses | 150,000 |
| Less change in depreciation | <u>10,000</u> |
| Change in taxable income | \$40,000 |
| Less taxes | <u>16,000</u> |
| Change in income after taxes | \$24,000 |
| Add depreciation | 10,000 |
| Less increase in working capital | <u>15,000</u> |
| Change in operating cash flow | \$19,000 |

So that we can mathematically represent how to calculate the change in operating cash flows for a project, let's use the symbol "Δ" to indicate "change in":

| | | |
|----------|---|-------------------------------|
| ΔOCF | = | change in operating cash flow |
| ΔR | = | change in revenues |
| ΔE | = | change in expenses |
| ΔD | = | change in depreciation |
| <i>t</i> | = | tax rate |
| ΔNWC | = | change in working capital |

The change in the operating cash flow is:

$$\Delta OCF = (\Delta R - \Delta E - \Delta D)(1 - t) + \Delta D - \Delta NWC$$

We can also write this as:

$$\Delta OCF = (\Delta R - \Delta E)(1 - t) + \Delta Dt - \Delta NWC$$

Applying these equations to the previous example,

$$\begin{aligned} \Delta OCF &= (\Delta R - \Delta E - \Delta D)(1 - t) + \Delta D - \Delta NWC \\ &= (\$200,000 - \$150,000 - \$10,000)(1 - 0.40) + \$10,000 - \$15,000 \\ &= \$19,000 \end{aligned}$$

or, using the rearrangement of the equation,

$$\begin{aligned} \Delta OCF &= (\Delta R - \Delta E)(1 - t) + \Delta Dt - \Delta NWC \\ &= (\$200,000 - \$150,000)(1 - 0.40) + \$10,000(0.40) - \$15,000 \\ &= \$19,000 \end{aligned}$$

Looking at one more example for the calculation of operating cash flows, consider evaluating equipment that is expected to reduce expenses by \$100,000 during the first year. And, since the new equipment is more efficient than the existing equipment, the existing equipment will be sold and replaced by this new equipment. Suppose that the depreciation on the equipment to be replaced would be \$20,000 for the coming year, but that the depreciation on the new equipment would be \$30,000. Therefore, depreciation increases by \$10,000 if the new equipment is bought. If the marginal tax rate is 30%, the depreciation tax shield increases from \$6,000 to \$9,000 for the coming year.

Net Cash Flows

By now we should know that an investment's cash flows consist of: (1) cash flows related to acquiring and disposing of the assets represented in the investment and (2) how it affects cash flows related to operations. To evaluate any investment project, we must consider both to determine whether the company is better off with or without it.

The sum of the cash flows from asset acquisition and disposition and from operations is referred to as net cash flows (NCF). And this sum is calculated for each period. In each period, we add the cash flow from asset acquisition and disposition and the cash flow from operations. For a given period,

$$\text{Net cash flow} = \text{Investment cash flow} + \text{Change in operating cash flow (i.e., } \Delta\text{OCF)}$$

The analysis of the cash flows of investment projects can become quite complex. But by working through any problem systematically, line-by-line, you will be able to sort out the information and focus on those items that determine cash flows.

To illustrate, suppose that the Acme Company is evaluating replacing its production equipment that produces anvils. The worksheet for calculating the cash flows for this illustration is shown in Table 14.1. The current equipment was purchased 10 years ago at a cost of \$1.5 million. Acme depreciated its current equipment using MACRS, considering the equipment to be a 5-year MACRS asset. If Acme sells the current equipment, it estimates that \$100,000 can be realized from the sale. The new equipment would cost \$2.5 million and would be depreciated as a 5-year MACRS asset. The new equipment would not affect sales, but would result in a costs savings of \$400,000 each year of the asset's 10-year useful life. At the end of its 10-year life, Acme estimates that it can sell the equipment for \$30,000. Also, because the new equipment would be more efficient, Acme would have less work-in-process anvils, reducing inventory needs initially by \$20,000. Acme's marginal tax rate is 40%.

TABLE 14.1 Worksheet for Computing the New Cash Flow for Acme Company

| | Year 0 | Year 1 | Year 2 | Year 3 | Year 4 | Year 5 | Year 6 | Year 7 | Year 8 | Year 9 | Year 10 |
|--|--------------|------------|------------|------------|------------|------------|------------|------------|------------|------------|------------|
| Initial payment | -\$2,500,000 | | | | | | | | | | |
| Sale of new | \$100,000 | | | | | | | | | | \$30,000 |
| Tax on sale of new | -\$40,000 | | | | | | | | | | -\$12,000 |
| Change in working capital, ΔWC | \$20,000 | | | | | | | | | | -\$20,000 |
| Investment cash flows | -\$2,420,000 | | | | | | | | | | -\$2,000 |
| Change in revenues, ΔR | \$0 | \$0 | \$0 | \$0 | \$0 | \$0 | \$0 | \$0 | \$0 | \$0 | \$0 |
| Change in expenses, ΔE | -\$400,000 | -\$400,000 | -\$400,000 | -\$400,000 | -\$400,000 | -\$400,000 | -\$400,000 | -\$400,000 | -\$400,000 | -\$400,000 | -\$400,000 |
| Change in depreciation, ΔD | \$500,000 | \$800,000 | \$480,000 | \$288,000 | \$288,000 | \$288,000 | \$144,000 | \$0 | \$0 | \$0 | \$0 |
| Change in taxable income, $(\Delta R - \Delta E - \Delta E)$ | -\$100,000 | -\$400,000 | -\$80,000 | \$112,000 | \$112,000 | \$112,000 | \$256,000 | \$400,000 | \$400,000 | \$400,000 | \$400,000 |
| Change in taxes, $t(\Delta R - \Delta E - \Delta E)$ | -\$40,000 | -\$160,000 | -\$32,000 | \$44,800 | \$44,800 | \$44,800 | \$102,400 | \$160,000 | \$160,000 | \$160,000 | \$160,000 |
| Change in after-tax income, $(1 - t)(\Delta R - \Delta E - \Delta E)$ | -\$60,000 | -\$240,000 | -\$48,000 | \$67,200 | \$67,200 | \$67,200 | \$153,600 | \$240,000 | \$240,000 | \$240,000 | \$240,000 |
| Change in depreciation, ΔD | \$500,000 | \$800,000 | \$480,000 | \$288,000 | \$288,000 | \$288,000 | \$144,000 | \$0 | \$0 | \$0 | \$0 |
| Change in operating cash flows | \$440,000 | \$560,000 | \$432,000 | \$355,200 | \$355,200 | \$355,200 | \$297,600 | \$240,000 | \$240,000 | \$240,000 | \$240,000 |
| Net cash flow | -\$2,420,000 | \$440,000 | \$560,000 | \$432,000 | \$355,200 | \$355,200 | \$297,600 | \$240,000 | \$240,000 | \$240,000 | \$238,000 |

Assume that the equipment purchase (and sale of the old equipment) occurs at the end of Year 0 and that the first year of operating this equipment is Year 1 and the last year of operating the equipment is Year 10.

The information for this illustration is

Tax basis of current equipment = \$0

Sale of current equipment = \$100,000

Tax on sale of current equipment = \$40,000

Initial outlay for new = -\$2,500,000

$\Delta E = \$400,000$

$\Delta WC = -\$20,000$ (initially)

$\Delta WC = \$20,000$ (at end of project)

Depreciation:

Year 1: $0.2000 (\$2,500,000) = \$500,000$

Year 2: $0.3200 (\$2,500,000) = \$800,000$

Year 3: $0.1920 (\$2,500,000) = \$480,000$

Year 4: $0.1152 (\$2,500,000) = \$288,000$

Year 5: $0.1152 (\$2,500,000) = \$288,000$

Another, more detailed example, is provided in Appendix 14.B.

Simplifications

To actually analyze a project's cash flows, we need to make several simplifications:

- We assume that cash flows into or out of the company at certain points in time, typically at the end of the year, although we realize a project's cash flows into and out of the company at irregular intervals.
- We assume that the assets are purchased and put to work immediately.
- By combining inflows and outflows in each period, we are assuming that all inflows and outflows in a given period have the same risk.

Because there are so many flows to consider, we focus on flows within a period (say a year), assuming they all occur at the end of the period. We assume this to reduce the number of things we have to keep track of. Whether or not this assumption matters depends on: (1) the difference between the actual time of cash flow and when we assume it flows at the end of the period (that is, a flow on January 2 is 364 days from December 31, but a flow on December 30 is only one day from December 31), and (2) the opportunity

cost of funds. Also, assuming that cash flows occur at specific points in time simplifies the financial mathematics we use in valuing these cash flows.

Keeping track of the different cash flows of an investment project can be taxing. Developing a checklist of things to consider can help you wade through the analysis of a project's cash flows.

BOTTOM LINE

- The type of project and the economic life of a project affect the cash flows and the method used to evaluate these cash flows.
- Determining whether an investment's benefits outweigh its costs requires that the CFO or the CFO's staff first estimate the future cash flows associated with the investment.
- The evaluation of a project requires estimating not only the initial outlay, but the expected cash flows at the end of the project's useful life.
- The estimation of operating cash flows requires estimation of revenues, expenses, taxes, any tax shield (or benefit) from taxes, as well as any anticipated changes in working capital needs.
- If a project requires a change in the company's net working capital accounts that persists for the duration of the project (e.g., an increase in inventory levels starting at the time of the investment), we tend to classify the change as part of the acquisition costs at the beginning of the project and as part of disposition proceeds at the end of project.
- If the change in net working capital is due to the fact that accrual accounting does not coincide with cash flows, we tend to classify the change as part of the operating cash flows.
- The goal in estimating cash flows is to arrive at the company's incremental cash flow for each period. This incremental cash flow includes both any investing and any operating cash flows related to the project.
- When a company undertakes a new project, the CFO and the CFO's staff want to know how it changes the company's total revenues, not merely the new product's revenues.
- The task of estimating the cash flows appears, at first, to be quite daunting, but this is an exercise that all companies must go through for every capital project.
- The amount of material that must be sorted through to determine the relevant information for this estimation is often substantial and it is the responsibility of the staff responsible for capital budgeting of the company to sort through this material, determine the relevant information, and organize it in such a way to enable the estimation of the cash flows in every period of the project's life.

APPENDIX 14.A: EXPECTED CASH FLOWS FROM THE DISPOSITION OF AN ASSET

Suppose a company is evaluating an asset that costs \$10,000 that it expects to sell in five years. Suppose further that the tax basis of the asset will be \$3,000 after five years and that the company's tax rate is 40%. What are the expected cash flows from disposing of this asset?

Case 1: Sell the asset for \$8,000 [Original cost > Expected sales price > Tax basis]

If the company expects to sell the asset for \$8,000 in five years, \$10,000 – \$3,000 = \$7,000 of the asset's cost will be depreciated, yet the asset lost only \$10,000 – \$8,000 = \$2,000 in value. Therefore, the company has overdepreciated the asset by \$5,000. Since this overdepreciation represents deductions to be taken on the company's tax returns over the five years that don't reflect the actual depreciation in value (the asset doesn't lose \$7,000 in value, only \$2,000), this \$5,000 is taxed at ordinary tax rates. If the company's tax rate is 40%, the tax = 40% × \$5,000 = \$2,000.

The cash flow from disposition is the sum of the direct cash flow (someone pays the company for the asset or the company pays another party to dispose of it) and the tax consequences. In this example, the cash flow is the \$8,000 the company expects someone to pay for the asset, less the \$2,000 in taxes the company expects to pay, or \$6,000 cash inflow.

Tax on disposition

| | |
|-------------------|--------------|
| Sales price | \$8,000 |
| Less tax basis | <u>3,000</u> |
| Gain | \$5,000 |
| Ordinary tax rate | <u>0.40</u> |
| Tax on recapture | \$2,000 |

Cash flows

| | |
|---------------------------|--------------|
| Proceeds from disposition | \$8,000 |
| Less tax on gain | <u>2,000</u> |
| Cash flow | \$6,000 |

Case 2: Sell the asset for \$12,000 [Expected sales price > Original cost > Tax basis]

Suppose instead that the company expects to sell this asset in five years for \$12,000. Again, the asset is overdepreciated by \$7,000. In fact, the asset is not expected to depreciate, but rather appreciate over the five years. The

\$7,000 in depreciation is recaptured after five years and taxed at ordinary rates: 40% of \$7,000, or \$2,800. The \$2,000 capital gain is the appreciation in the value of the asset and may be taxed at special rates. Assuming the tax rate on capital gain income is 30%, the company expects to pay 30% of \$2,000, or \$600 in taxes on this gain. Selling the asset in five years for \$12,000 therefore results in an expected cash inflow of \$12,000 – 2,800 – 600 = \$8,600.

| | | |
|--------------------|--------------------------|---------------|
| Tax on disposition | | |
| | Sales price | \$12,000 |
| | Less original cost | <u>10,000</u> |
| | Capital gain | \$2,000 |
| | Capital gains tax rate | <u>0.30</u> |
| | Tax on capital gain | \$600 |
| | Original cost | \$10,000 |
| | Less tax basis | <u>3,000</u> |
| | Gain (recapture) | \$7,000 |
| | Ordinary tax rate | <u>0.40</u> |
| | Tax on recapture | \$2,800 |
| Cash flows | | |
| | Cash flow from sale | \$12,000 |
| | Less tax on capital gain | 600 |
| | Less tax on recapture | <u>2,800</u> |
| | Cash flow | \$8,600 |

Case 3: Sell the asset for \$1,000 [Tax basis > Expected sales price]

Suppose the company expects to sell the asset in five years for \$1,000. If the company can reduce its ordinary taxable income by the amount of the capital loss, \$3,000 – 1,000 = \$2,000, its tax liability will be 40% of \$2,000, or \$800 because of this loss. The loss “shields” \$2,000 of income from taxes. Combining the \$800 tax reduction with the cash flow from selling the asset, the \$1,000, gives the company a cash inflow of \$1,800.

| | | |
|---------------------------|--------------------|--------------|
| Tax shield on disposition | | |
| | Tax basis | \$3,000 |
| | Sales price | <u>1,000</u> |
| | Loss on sale | \$2,000 |
| | Ordinary tax rate | <u>0.40</u> |
| | Tax shield on loss | \$800 |

| | | |
|------------|---------------------------|------------|
| Cash flows | | |
| | Proceeds from disposition | \$1,000 |
| | Plus tax shield on loss | <u>800</u> |
| | Cash flow | \$1,800 |

APPENDIX 14.B: EXPANSION OF THE WILLIAMS 5 & 10

The Problem

The Williams 5 & 10 Company is a discount retail chain, selling a variety of goods at low prices. Business has been very good lately and the Williams 5 & 10 Company is considering opening one more retail outlet in a neighboring town at the end of 20Y0. They figure that it would be about five years before a large national chain of discount stores moves into that town to compete with its store. So it is looking at this expansion as a five-year prospect. After five years, it would most likely retreat from this town.

Williams's managers have researched the expansion and determined that the building needed could be built for \$400,000 and it would cost \$100,000 to buy the cash registers, shelves, and other equipment necessary to start up this outlet. Under MACRS, the building would be classified as 31.5-year property and depreciated using the straight-line method, with no salvage value. This means that $1/31.5$ of the \$400,000 is depreciated each year. Also under MACRS, the equipment would be classified as 5-year property. The Williams 5 & 10 expects to be able to sell the building for \$350,000 and the equipment for \$50,000 after five years.

The Williams 5 & 10 extends no credit on its sales and pays for all its purchases immediately. The projections for sales and expenses for the new store for the next five years are:

| Year | Sales | Expenses |
|------|-----------|-----------|
| 20Y1 | \$200,000 | \$100,000 |
| 20Y2 | 300,000 | 100,000 |
| 20Y3 | 300,000 | 100,000 |
| 20Y4 | 300,000 | 100,000 |
| 20Y5 | 50,000 | 20,000 |

The new store requires \$50,000 of additional inventory. Since all sales are in cash, there is no expected increase in accounts receivable. However, the firm anticipates no other changes in working capital. The tax rate is a flat 30% and there are no investment tax credits associated with this expansion. Also, capital gains are taxed at the ordinary tax rate.

The Analysis

To determine the relevant cash flows to evaluate this expansion, let's look at this problem bit-by-bit.

The Williams 5 & 10 Company is a discount retail chain, selling a variety of goods at low prices. Business has been very good lately and the Williams 5 & 10 Company is considering opening one more retail outlet in a neighboring town at the end of 20Y0.

This is an expansion of the business into a new market. Since Williams has other similar outlets, this is most likely a low-risk type of investment.

They figure that it would be about five years before a large national chain of discount stores moves into that town to compete with its store. So it is looking at this expansion as a 5-year prospect. After five years it would most likely retreat from this town.

The economic life of this project is five years. They expect to expand into this market for only five years, leaving when a competitor enters.

Williams's managers have researched the expansion and determined that the building needed could be built for \$400,000 and it would cost \$100,000 to buy the cash registers, shelves, and other equipment necessary to start up this outlet.

The initial outlay for the building and equipment is \$500,000. There are no setup charges, so we can assume that all other initial investment costs are included in these figures. We assume that the outlay for the building and equipment is concentrated at the end of 20Y0, but that the building and equipment are not put in service until 20Y1, which becomes the first year that depreciation may be expensed on the building and equipment for tax purposes.

Under MACRS, the building would be classified as 31.5-year property and depreciated using the straight-line method with no salvage value. This means that $1/31.5$ of the \$400,000 is depreciated each year. Also under MACRS, the equipment would be classified as 5-year property.

The depreciation expense for each year is:

| Year | Building | Equipment | Total |
|-------|---------------|---------------|----------|
| 20Y1 | \$12,698 | \$20,000 | \$32,698 |
| 20Y2 | 12,698 | 32,000 | 44,698 |
| 20Y3 | 12,698 | 19,200 | 31,898 |
| 20Y4 | 12,698 | 11,520 | 24,218 |
| 20Y5 | <u>12,698</u> | <u>11,520</u> | 24,218 |
| Total | \$63,490 | \$94,240 | |

The tax basis of the building and equipment decline each year, but at different rates, as shown in Figure 14.2.

The tax basis of the building and equipment at the end of the fifth year are:

$$\text{Tax basis of building} = \$400,000 - \$63,490 = \$336,510$$

and

$$\text{Tax basis of equipment} = \$100,000 - \$94,240 = \$5,760$$

The Williams 5 & 10 expects to sell the building for \$350,000 and the equipment for \$50,000 after five years.

FIGURE 14.2 Tax Basis of the Building and Equipment, Years 20Y0 through 20Y5

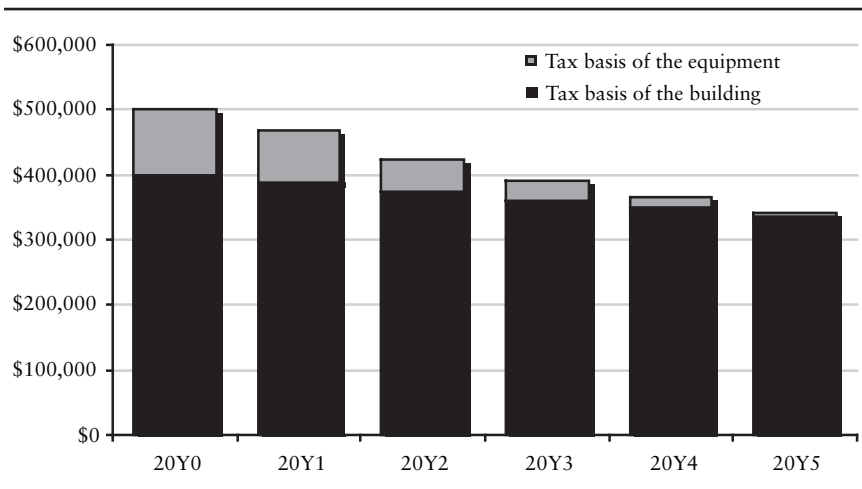

The sale of the building is a cash inflow of \$350,000 at the end of the fifth year. The building is expected to be sold for more than its book value, creating a taxable gain of $\$350,000 - \$336,510 = \$13,490$. The tax on this gain is \$4,047.

The sale of the equipment is a cash inflow of \$50,000. The gain on the sale of the equipment is $\$50,000 - \$5,760 = \$44,240$. The tax on this gain is 30% of \$44,240, or \$13,272.

Williams extends no credit on its sales and pays for all its purchases immediately. The projections for sales and expenses for the new store for the next five years are:

| Year | Sales | Expenses |
|------|-----------|-----------|
| 20Y1 | \$200,000 | \$100,000 |
| 20Y2 | 300,000 | 100,000 |
| 20Y3 | 300,000 | 100,000 |
| 20Y4 | 300,000 | 100,000 |
| 20Y5 | 50,000 | 20,000 |

The change in revenues, ΔR , and the change in cash expenses, ΔE , correspond to the sales and costs figures.

The new store would require \$50,000 of additional inventory. Since all sales are in cash, there is no expected increase in accounts receivable. However, the firm anticipates no other changes in working capital.

The increase in inventory is an investment of cash when the store is opened, a \$50,000 cash outflow. That is the amount Williams has to invest to maintain inventory while the store is in operation. When the store is closed in five years, there is no need to keep this increased level of inventory.

If we assume that the inventory at the end of the fifth year can be sold for \$50,000, that amount will be a cash inflow at that time. Since this is a change in working capital for the duration of the project, we include this cash flow as part of the asset acquisition (initially) and its disposition (at the end of the fifth year).

The tax rate is a flat 30% and there are no investment tax credits associated with this expansion. Also, capital gains are taxed at the ordinary tax rate of 30%.

Once we know the tax rate we can calculate the cash flows related to acquiring and disposing of assets and the cash flows from operations.

We can calculate the cash flows from operations in the following manner:

| Year | ΔR | ΔE | ΔD | $(\Delta R - \Delta E - \Delta D)(1 - \tau)$ | $(\Delta R - \Delta E)(1 - \tau) + \Delta D\tau$ |
|------|------------|------------|------------|--|--|
| 20Y1 | \$200,000 | \$100,000 | \$32,698 | \$47,111 | \$79,809 |
| 20Y2 | 300,000 | 100,000 | 44,698 | 108,711 | 153,409 |
| 20Y3 | 300,000 | 100,000 | 31,898 | 117,671 | 149,569 |
| 20Y4 | 300,000 | 100,000 | 24,218 | 123,047 | 147,265 |
| 20Y5 | 50,000 | 20,000 | 24,218 | 4,047 | 28,265 |

Or, we can calculate the incremental operating cash flows from the new store using the other operating cash flow equation:

| Year | ΔR | ΔE | $(\Delta R - \Delta E)(1 - \tau)$ | $\Delta D\tau$ | $(\Delta R - \Delta E)(1 - \tau) + \Delta D\tau$ |
|------|------------|------------|-----------------------------------|----------------|--|
| 20Y1 | \$200,000 | \$100,000 | \$70,000 | \$9,809 | \$79,809 |
| 20Y2 | 300,000 | 100,000 | 140,000 | 13,409 | 153,409 |
| 20Y3 | 300,000 | 100,000 | 140,000 | 9,569 | 149,569 |
| 20Y4 | 300,000 | 100,000 | 140,000 | 7,265 | 147,265 |
| 20Y5 | 50,000 | 20,000 | 21,000 | 7,265 | 28,265 |

The pieces of this cash flow puzzle are assembled in Table 14.2, which identifies the cash inflows and outflows for each year, with acquisition and disposition cash flows at the top and operating cash flows below.

Investing \$550,000 initially is expected to result in cash inflows during the following five years, as shown in Figure 14.3.

FIGURE 14.3 Net Cash Flows from the Williams 5 & 10 Project

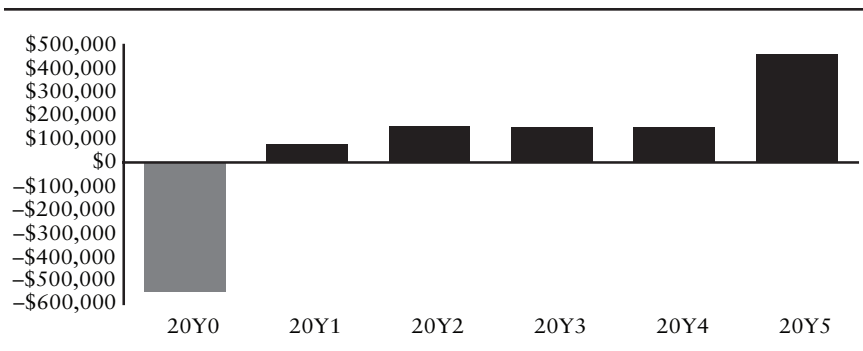

TABLE 14.2 Worksheet for the Williams 5 & 10 Expansion Project

| | End of Year | | | | | |
|--------------------------------|----------------|----------------|----------------|----------------|----------------|----------------|
| | 20Y0 | 20Y1 | 20Y2 | 20Y3 | 20Y4 | 20Y5 |
| Investment cash flows | | | | | | |
| Purchase and sale of building | -\$400,000 | | | | | \$350,000 |
| Tax on sale of building | | | | | | -4,047 |
| Purchase and sale of equipment | -100,000 | | | | | 50,000 |
| Tax on sale of equipment | | | | | | -13,272 |
| Change in working capital | <u>-50,000</u> | - | - | - | - | <u>50,000</u> |
| Investment cash flows | -\$550,000 | | | | | \$432,681 |
| Change in operating cash flows | | | | | | |
| Change in revenues | \$200,000 | \$300,000 | \$300,000 | \$300,000 | \$300,000 | \$50,000 |
| Less change in expenses | -100,000 | -100,000 | -100,000 | -100,000 | -100,000 | -20,000 |
| Less change in depreciation | <u>-32,698</u> | <u>-44,698</u> | <u>-44,698</u> | <u>-31,898</u> | <u>-24,218</u> | <u>-24,218</u> |
| Change in taxable income | \$67,302 | \$155,302 | \$155,302 | \$168,102 | \$175,782 | \$5,782 |
| Less taxes | <u>-20,191</u> | <u>-46,591</u> | <u>-50,531</u> | <u>-52,735</u> | <u>-52,735</u> | <u>-1,735</u> |
| Change in income after tax | \$47,111 | \$108,711 | \$108,711 | \$117,671 | \$123,047 | \$4,047 |
| Add change in depreciation, | <u>32,698</u> | <u>44,698</u> | <u>44,698</u> | <u>31,898</u> | <u>24,218</u> | <u>24,218</u> |
| Change in operating cash flows | \$79,809 | \$153,409 | \$153,409 | \$149,569 | \$147,265 | \$28,265 |
| Net cash flows | -\$550,000 | \$79,809 | \$153,409 | \$149,569 | \$147,265 | \$460,946 |

Capital Budgeting Techniques

AGENDA

- Item 1* Explain the most commonly used capital budgeting techniques: net present value, profitability index, internal rate of return, modified internal rate of return, payback period, discounted payback period.
- Item 2* Understand the relation between the techniques used to evaluate and select projects, and the objectives of the company.
- Item 3* Identify what factors a capital budgeting technique should consider in evaluating an investment.
- Item 4* For a given capital budgeting technique, explain the rule for determining whether a project is acceptable and for how to select among mutually exclusive projects.
- Item 5* Compare and contrast the capital budgeting techniques.
- Item 6* Recognize the potential problems in applying the techniques and understand the appropriate techniques to use in selecting projects in cases when the project lives or risks are different, when choosing among mutually exclusive projects, or when making decisions when the capital budget is limited.
- Item 7* Explain how the measures used for evaluating responsibility managers may conflict with capital budgeting techniques, potentially leading to the selection of the wrong projects.
- Item 8* Explain the problems associated with using capital budgeting to justify the adoption of new technologies.

The value of a company today is the present value of all its future cash flows, where these future cash flows come from assets that are already in place and from future investment *opportunities*. These future cash flows are discounted at a rate that represents investors' assessments of the uncertainty that they will flow in the amounts and when expected. The value of the company is represented simply as:

$$\text{Value of the company} = \sum_{t=1}^{\infty} \frac{CF_t}{(1+r)^t}$$

where CF_t is the cash flow in period t , and r is the required rate of return. The CFO makes decisions by evaluating which capital projects, if any, are expected to enhance the value of the company. This process is referred to as capital budgeting.

The capital budgeting decisions for a project require analysis of:

- The project's future cash flows.
- The degree of uncertainty associated with the project's future cash flows.
- The value of the project's future cash flows considering their uncertainty.

We looked at how to estimate cash flows in the previous chapter where we were concerned with a project's incremental cash flows, comprising changes in operating cash flows (change in revenues, expenses, and taxes) and changes in investment cash flows (the firm's incremental cash flows from the acquisition and disposition of the project's assets).

And we know the concept behind uncertainty: The more uncertain a future cash flow, the less it is worth today. The degree of uncertainty, or risk, is reflected in a project's cost of capital. The cost of capital is what the company must pay for the funds to finance its investments. The cost of capital may be an explicit cost (for example, the interest paid on debt) or an implicit cost (for example, the expected price appreciation of its shares of common stock).

In this chapter, we focus on evaluating the future cash flows. Given estimates of incremental cash flows for a project and given a cost of capital that reflects the project's risk, we look at alternative techniques that are used to select projects.

For now all we need to understand about a project's risk is that we can incorporate risk in either of two ways: (1) We can discount future cash flows using a higher discount rate, the greater the cash flow's risk, or (2) we can require a higher return on a project, the greater the risk of its cash flows.

EVALUATION TECHNIQUES

Look at the incremental cash flows for Project X and Project Y shown in Table 15.1. Can you tell by looking at the cash flows for Investment A whether it enhances wealth? Or, can you tell by just looking at Investments A and B which one is better? Perhaps with some projects you may think you can pick out which one is better simply by gut feeling or eyeballing the cash flows. But why do it that way when there are precise methods to evaluate investments by their cash flows?

TABLE 15.1 Estimated Cash Flows for Investments X and Y

| Year | End-of-Period Cash Flows | |
|------|--------------------------|--------------|
| | Project X | Project Y |
| 0 | -\$1,000,000 | -\$1,000,000 |
| 1 | 0 | 325,000 |
| 2 | 200,000 | 325,000 |
| 3 | 300,000 | 325,000 |
| 4 | 900,000 | 325,000 |

The first step is to determine the cash flows from each investment and then assess the uncertainty of all the cash flows in order to evaluate investment projects and select the investments that maximize wealth.

In this chapter, there are six techniques discussed that are commonly used by companies to evaluate investments in long-term assets:

1. Net present value
2. Profitability index
3. Internal rate of return
4. Modified internal rate of return
5. Payback period
6. Discounted payback period

The focus of the analysis of these techniques is on how well each technique discriminates among the different projects, steering the CFO toward the projects that maximize the value of the company.

An evaluation technique should:

- Consider all the future incremental cash flows from the project.
- Consider the time value of money.
- Consider the uncertainty associated with future cash flows.
- Have an objective criterion by which to select a project.

Projects selected using a technique that satisfies all four criteria will, under most general conditions, maximize owners' wealth. In addition to judging whether each technique satisfies these criteria, this chapter also looks at which ones can be used in special situations, such as when a dollar limit is placed on the capital budget.

Cost of Capital, Required Rate of Return, and Discount Rate

In several of the capital budgeting evaluation techniques, the uncertain future cash flows of a project are discounted to the present at some interest rate that reflects the degree of uncertainty associated with this future cash flow. These *discounted cash flow techniques* are the net present value method, the profitability index, and the modified internal rate of return. In each of these, the more uncertain the future cash flow, the less the cash flow is worth today—this means that a higher discount rate is used to translate it into a value today. In the case of the internal rate of return, the uncertainty is reflected in the hurdle rate that must be exceeded by the project's return: The greater the uncertainty of future cash flows, the higher is this hurdle rate.

This rate—whether a discount rate or a hurdle rate—reflects the opportunity cost of funds. In the case of a corporation, the opportunity cost of funds reflects the *cost of capital* to be paid the suppliers of capital (the creditors and owners).

The cost of capital comprises the *required rate of return (RRR)* (that is, the return suppliers of capital demand on their investment) and the cost of raising new capital if the firm cannot generate the needed capital internally (that is, from retaining earnings). The cost of capital and the required rate of return are the same concept, but from different perspectives. Therefore, we will use the terms interchangeably in our study of capital budgeting.

This rate is the project's cost of capital—the return required by the suppliers of capital (creditors and owners) to compensate them for time value of money and the risk associated with the investment. The more uncertain the future cash flows, the greater the cost of capital.

NET PRESENT VALUE

If an investment requires the payment of \$1 million today and promises to return \$1.5 million two years from today and if the opportunity cost for projects of similar risk is 12%, is this a good investment? To determine whether this is a good investment the initial investment of \$1 million is compared with the \$1.5 million cash flow expected in two years. Because the discount rate of 10% reflects the degree of uncertainty associated with the \$1.5 million expected in two years, today it is worth:

$$\begin{aligned} \text{Present value of \$1.5 million to be received in 2 years} &= \frac{\$1 \text{ million}}{(1 + 0.10)^2} \\ &= \$1.2397 \text{ million} \end{aligned}$$

By investing \$1 million today, the company is getting in return a promise of a cash flow in the future that is worth \$1.2397 million today. The company is expected to increase its value by \$1.2397 – \$1 million = \$0.2397 million if it makes this investment. In other words, the expected value added with this investment is \$0.2397 million.

Another way of stating this is that the present value of the \$1.5 million cash inflow is \$1.2397 million, which is more than the \$1 million today's cash outflow to make the investment. Subtracting today's cash outflow to make an investment from the present value of the cash inflow from the investment provides the increase or decrease in the company's value, which is referred to as the investment's *net present value*.

The net present value is the present value of all expected cash flows:

$$\text{Net present value} = \text{Present value of all expected cash flows}$$

The word *net* in this term indicates that all cash flows—both positive and negative—are considered. Often the changes in operating cash flows are inflows and the investment cash flows are outflows. Therefore we tend to refer to the net present value as the difference between the present value of the cash inflows and the present value of the cash outflows.

Calculating the Net Present Value

We can represent the net present value (NPV) using summation notation, where t indicates any particular period, CF_t represents the cash flow at the end of period t , r represents the cost of capital, and N the number of periods comprising the economic life of the investment:

$$\text{NPV} = \frac{\text{Present value of cash inflows}}{\text{Present value of cash outflows}} = \sum_{t=1}^N \frac{CF_t}{(1+r)^t}$$

Cash inflows are positive values of CF_t and cash outflows are negative values of CF_t . For any given period t , the cash flows (positive and negative) are collected and netted together.

Take another look at Projects X. Using a 10% cost of capital, the present values of the cash flows are:

| Project X | | |
|-----------|--------------|----------------------|
| Year | Cash Flow | Discounted Cash Flow |
| 0 | -\$1,000,000 | -\$1,000,000.00 |
| 1 | 0 | 0.00 |
| 2 | 200,000 | 165,289.26 |
| 3 | 300,000 | 225,394.44 |
| 4 | 900,000 | 614,712.11 |
| | | NPV = +\$5,395.81 |

This NPV indicates that with investing in Project X, there is an expected increase in the value of the company by \$5,395.81. Calculated in a similar manner, the NPV of Project Y is \$30,206.27.¹

A positive NPV means that the investment increases the value of the company—the return is more than sufficient to compensate for the required return of the investment. A negative NPV means that the investment decreases the value of the company—the return is less than the cost of capital. A zero NPV means that the return just equals the return required by owners to compensate them for the degree of uncertainty of the investment's future cash flows and the time value of money. Therefore,

| If... | this means that... | and the company ... |
|-----------|---|---|
| NPV > \$0 | the investment is expected to increase shareholder wealth | should accept the project. |
| NPV < \$0 | the investment is expected to decrease shareholder wealth | should reject the project. |
| NPV = \$0 | the investment is expected not to change shareholder wealth | should be indifferent between accepting or rejecting the project. |

Project X is expected to increase the value of the company by \$5,395.81, whereas Project Y is expected to add \$30,206.27 in value. If these are independent investments, both should be taken on because both increase the value of the company. If X and Y are *mutually exclusive*, such that the only choice is either X or Y, then Y is preferred since it has the greater NPV. As explained in the previous chapter, projects are said to be mutually exclusive if accepting one precludes the acceptance of the other.

¹ A financial calculator or spreadsheet program, such as Microsoft's Excel, may be used to solve for the NPV as well.

Investment Profile

A CFO may want to see how sensitive is the decision to accept a project to changes in the estimate of the project's cost of capital. The *investment profile* (also known as the *net present value profile*) is a depiction of the NPVs for different discount rates, which allows an examination of the sensitivity in how a project's NPV changes as the discount rate changes. The investment profile is a graphical depiction of the relation between the NPV of a project and the discount rate: The profile shows the NPV of a project for each discount rate, within some range.

The NPV profile for Project X is shown in Figure 15.1 for discount rates from 0% to 20%. As shown in the figure, the NPV of Project X is positive for discount rates from 0% to 10.172%, and negative for discount rates higher than 10.172%. As explained later in this chapter, the 10.172% is the internal rate of return, that is, the discount rate at which the net present value is equal to zero. Therefore, Project X increases owners' wealth if the project's cost of capital on this project is less than 10.172% and decreases owners' wealth if the cost of capital on this project is greater than 10.172%.

Imposing the NPV profile of Project Y onto the NPV profile of Project X, as shown in the graph in Figure 15.2, the projects may be compared. If Projects X and Y are mutually exclusive projects—that is, the company may invest in only one or neither project—this graph clearly shows that the project selected depends on the discount rate. For higher discount rates, Project

FIGURE 15.1 The Investment Profile of Project X

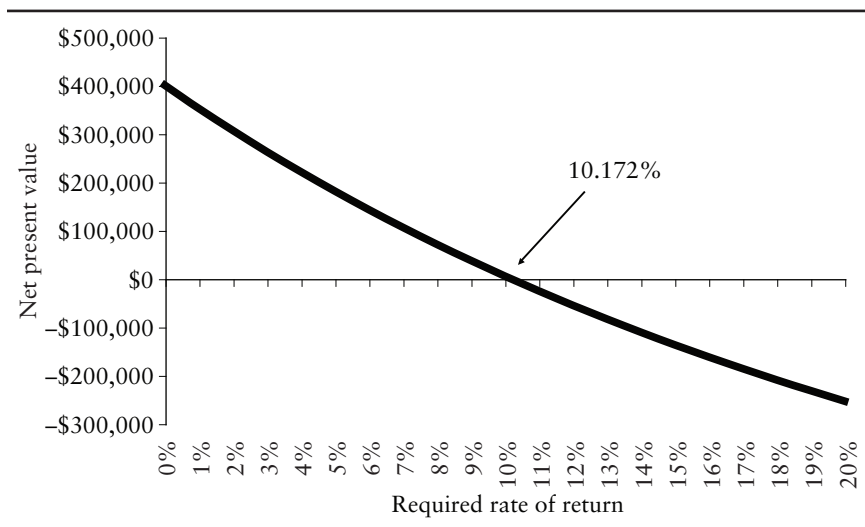
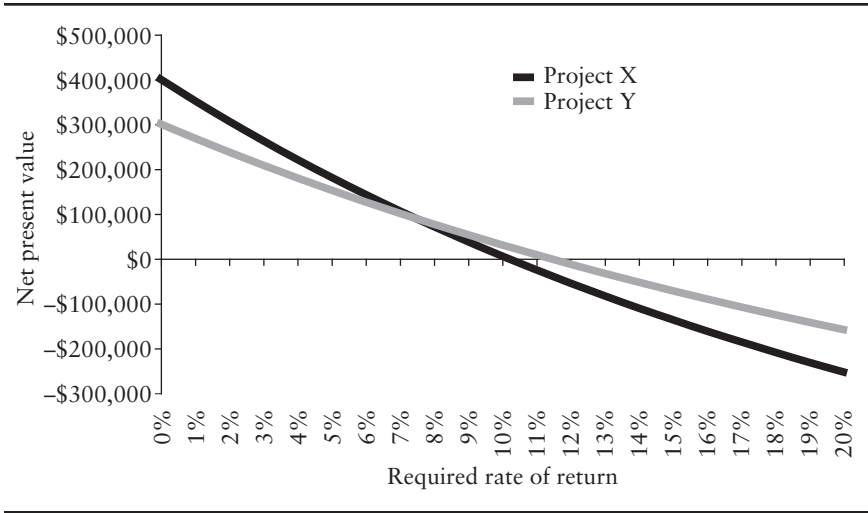

FIGURE 15.2 Investment Profiles of Investments X and Y



X's NPV is less than that of Project Y. This is because most of Project X's present value is attributed to the large cash flows four and five years into the future. The present value of the more distant cash flows is more sensitive to changes in the discount rate than is the present value of cash flows nearer the present.

If the discount rate is less than 7.495%, Project X adds more values than Project Y. If the discount rate is more than 7.495% but less than 11.338%, Project Y increases wealth more than Project X. If the discount rate is greater than 11.338%, we should invest in neither project because both would decrease wealth.

The 7.495% is the *cross-over discount rate*, which is the discount rate that produces identical NPVs for the two projects. If the discount rate is 7.495%, the NPV of both investments is \$88,660.²

Solving for the Cross-Over Rate

For Projects X and Y, the cross-over rate is the rate that causes the NPV of the two investments to be equal. Basically, this boils down to a simple approach: Calculate the differences in the cash flows and then solve for the internal rate of return of these differences.

² The precise cross-over rate is 7.49475%, at which the NPV for both projects is \$88,659.

| Year | Project X | Project Y | Difference |
|------|--------------|--------------|------------|
| 0 | -\$1,000,000 | -\$1,000,000 | \$0 |
| 1 | 0 | 325,000 | -325,000 |
| 2 | 200,000 | 325,000 | -125,000 |
| 3 | 300,000 | 325,000 | -25,000 |
| 4 | 900,000 | 325,000 | 575,000 |

The internal rate of return of these differences is the cross-over rate. Does it matter which project's cash flows you deduct from the other? Not at all—just be consistent each period.

PROFITABILITY INDEX

The *profitability index* uses some of the same information we used for the net present value, but it is stated in terms of an index. Whereas the NPV is:

$$\text{NPV} = \frac{\text{Present value of cash inflows}}{\text{Present value of cash outflows}} = \sum_{t=1}^N \frac{\text{CF}_t}{(1+r)^t}$$

The profitability index, PI, is:

$$\text{PI} = \frac{\frac{\text{Present value of cash inflows}}{\text{Present value of cash outflows}}}{\sum_{t=1}^N \frac{\text{CIF}_t}{(1+r)^t}} = \frac{\sum_{t=1}^N \frac{\text{CIF}_t}{(1+r)^t}}{\sum_{t=1}^N \frac{\text{COF}_t}{(1+r)^t}}$$

where CIF and COF are cash inflows and cash outflows, respectively. For Project X, the CIF is

| Year | Project X | |
|------|-----------|----------------------|
| | Cash Flow | Discounted Cash Flow |
| 1 | \$0 | \$0.00 |
| 2 | 200,000 | 165,289.26 |
| 3 | 300,000 | 225,394.44 |
| 4 | 900,000 | <u>614,712.11</u> |

$$\sum_{t=1}^N \frac{\text{CIF}_t}{(1+r)^t} = +\$1,005,395.81$$

Therefore, the profitability index is:

$$PI_x = \frac{\$1,005,395.81}{\$1,000,000} = 1.0054$$

The index value is greater than one, which means that the investment produces more in terms of benefits than costs.³ An advantage of using the profitability index is that it translates the dollar amount of NPV into an indexed value, providing a measure of the benefit per dollar investment. This is helpful in ranking projects in cases in which the capital budget is limited.

The decision rule for the profitability index therefore depends on the PI relative to 1.0:

| If... | this means that... | and you... |
|----------|---|---|
| PI > 1.0 | the investment is expected to increase shareholder wealth | should accept the project. |
| PI < 1.0 | the investment is expected to decrease shareholder wealth | should reject the project. |
| PI = 1.0 | the investment is expected not to change shareholder wealth | should be indifferent between accepting or rejecting the project. |

INTERNAL RATE OF RETURN

Suppose an investment opportunity requires an initial investment of \$1 million and has expected cash inflows of \$0.6 million after one year and another \$0.6 million after two years. This opportunity is shown in Figure 15.3 using a timeline.

The return on this investment (denoted by IRR in the equation below) is the discount rate that causes the present values of the \$0.6 million cash inflows to equal the present value of the \$1 million cash outflow, calculated as:

$$\$1 = \frac{\$0.6}{(1 + \text{IRR})^1} + \frac{\$0.6}{(1 + \text{IRR})^2}$$

Another way to look at this is to consider the investment's cash flows discounted at the IRR of 10%. The NPV of this project if the discount rate is 13.0662% (the IRR in this example) is zero:

³ There is no direct solution for PI in most financial calculators; what needs to be done is calculate the present value of all the cash inflows and then divide this value by the present value of the cash outflows. In the case of Project X, there is only one cash outflow and it is already in present value terms.

FIGURE 15.3 Timeline of Investment Opportunity

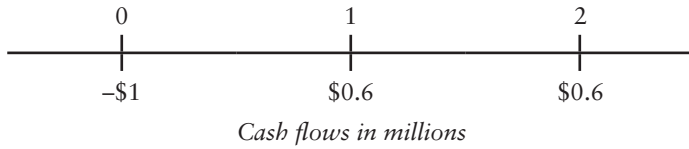

$$0 = \frac{\$0.6}{(1 + 0.13662)^1} + \frac{\$0.6}{(1 + 0.13662)^2} - \$1$$

An investment’s *internal rate of return (IRR)* is the discount rate that makes the present value of all expected future cash flows equal to zero. We can represent the IRR as the rate that solves:

$$\$0 = \sum_{t=1}^N \frac{CF_t}{(1 + IRR)^t}$$

Going back to Project X, the IRR for this project is the discount rate that solves:

$$0 = \frac{\$0}{(1 + IRR)^1} + \frac{\$200,000}{(1 + IRR)^2} + \frac{\$300,000}{(1 + IRR)^3} + \frac{\$900,000}{(1 + IRR)^4} - \$1,000,000$$

Using a calculator or a computer, we get 10.172% per year.

Looking back at the investment profiles of Projects X and Y, each profile crosses the horizontal axis (where NPV = 0) at the discount rate that corresponds to the investment’s IRR. This is no coincidence: By definition, the IRR is the discount rate that causes the project’s NPV to equal zero.

The IRR is a yield—what is earned, on average, per year. How do you use it to decide which investment, if any, to choose? Let’s revisit Projects X and Y and the IRRs we just calculated for each. If, for similar risk investments, owners earn 10% per year, then both Projects X and Y are attractive. They both yield more than the rate owners require for the level of risk of these two investments:

| Project | IRR | Cost of Capital |
|---------|---------|-----------------|
| X | 10.172% | 10% |
| Y | 11.388% | 10% |

The decision rule for the IRR is to invest in a project if it provides a return greater than the cost of capital. The cost of capital, in the context of

the IRR, is a *hurdle rate*—the minimum acceptable rate of return. For independent projects and situations in which there is no capital rationing, then

| If... | this means that... | and you... |
|-----------------------|---|---|
| IRR > cost of capital | the investment is expected to increase shareholder wealth | should accept the project. |
| IRR < cost of capital | the investment is expected to decrease shareholder wealth | should reject the project. |
| IRR = cost of capital | the investment is expected not to change shareholder wealth | should be indifferent between accepting or rejecting the project. |

IRR and Mutually Exclusive Projects

What if the CFO is forced to choose between Projects X and Y because the projects are mutually exclusive? Project Y has a higher IRR than Project X—so at first glance we might want to accept Project Y. What about the NPV of Projects X and Y? What does the NPV tell us to do? If we use the higher IRR, it tells us to go with Project Y. If we use the higher NPV and the cost of capital is 10%, we go with Project X. Which is correct? Choosing the project with the higher NPV is consistent with maximizing owners' wealth. Why? Because if the cost of capital is 10%, we would calculate different NPVs and come to a different conclusion, as shown using the investment profiles in Figure 15.2.

When evaluating mutually exclusive projects, the project with the highest IRR may not be the one with the best NPV.⁴ The IRR may give a different decision than NPV when evaluating mutually exclusive projects because of the assumption about what rate can be earned when reinvesting the cash flows. While we have not discussed this assumption, it is a property of any yield calculation and the IRR is a yield calculation. To realize the computed yield, it is assumed that the cash flows are reinvested at the computed IRR. Thus we have:

- NPV assumes cash flows reinvested at the cost of capital.
- IRR assumes cash flows reinvested at the internal rate of return.

⁴ It may or may not—and that is the problem. It is possible to make a value-maximizing decision by using the IRR method, but it is also possible to make a decision that is not value-maximizing by using IRR.

This reinvestment assumption may cause different decisions in choosing among mutually exclusive projects when:

- The timing of the cash flows is different among the projects.
- There are scale differences (that is, very different cash flow amounts).
- The projects have different useful lives.

With respect to the role of the timing of cash flows in choosing between two projects: Project Y's cash flows are received sooner than Project X's. Part of the return on either is from the reinvestment of its cash inflows. And in the case of Y, there is more return from the reinvestment of cash inflows. The question is what is done by the company with the cash inflows from a project when they are received. We generally assume that when the company receives cash inflows, they are reinvested in other assets.

With respect to the reinvestment rate assumption in choosing between these projects: Suppose we can reasonably expect to earn only the cost of capital on our investments. Then for projects with an IRR above the cost of capital we would be overstating the return on the investment using the IRR.

With respect to the NPV method: If the best we can do is reinvest cash flows at the cost of capital, the NPV assumes reinvestment at the more reasonable rate (the cost of capital). If the reinvestment rate is assumed to be the project's cost of capital, evaluate projects on the basis of the NPV and select the one that maximizes owners' wealth.

IRR and Capital Rationing

Capital rationing means that there is a limit on the capital budget. Suppose Projects X and Y are *independent projects*. As explained in the previous chapter, projects are independent if the acceptance of one does not prevent the acceptance of the other. And suppose the capital budget is limited to \$1 million. In our example, the CFO would therefore be forced to choose between Projects X or Y. Choosing the project with the highest IRR, Project Y should be chosen. But Project Y is expected to increase wealth less than Project X at the projects' 10% cost of capital. Therefore, ranking investments on the basis of their IRRs may not maximize wealth.

This dilemma is similar to that in the case of mutually exclusive projects using the projects' investment profiles. The discount rate at which Project X's NPV is zero is where Project X's IRR is 10.172%, where the project's investment profile crosses the horizontal axis. Likewise, the discount rate at which Project Y's NPV is zero is where Project Y's IRR is 11.388%. The discount rate at which Project X's and Y's investment profiles cross is the

cross-over rate, 7.495%. For discount rates less than 7.495%, Project X has the higher NPV. For discount rates greater than 7.495%, Project Y has the higher NPV. If Project Y is chosen because it has a higher IRR and if Project Y's cost of capital is less than 7.495%, the company has not chosen the project that produces the greatest value.

The source of the problem in the case of capital rationing is that the IRR is a percentage, not a dollar amount. Because of this, we cannot determine how to distribute the capital budget to maximize wealth because the investment or group of investments producing the highest yield do not necessarily produce the greatest wealth.

Multiple Internal Rates of Return

The typical project usually involves only one large negative cash flow initially, followed by a series of future positive flows. But that's not always the case. Suppose you are involved in a project that uses environmentally sensitive chemicals. It may cost a great deal to dispose of them. And that will mean a negative cash flow at the end of the project.

Suppose we are considering a project that has cash flows as follows:

| Year | End-of-Year Cash Flow |
|------|-----------------------|
| 0 | -\$1,000 |
| 1 | +1,000 |
| 2 | +500 |
| 3 | -2,100 |

What is this project's IRR? One possible solution is $IRR = 7.77\%$, yet another possible solution is $IRR = 33.24\%$. That is, both IRRs will make the present value of the cash flows equal to zero.

The NPVs of these cash flows are shown in Figure 15.4 for discount rates from 0% to 40%. Remember that the IRR is the discount rate that causes the NPV to be zero. In terms of Figure 15.4, this means that the IRR is the discount rate where the NPV is zero, the point at which the present value changes sign—from positive to negative or from negative to positive. In the case of this project, the present value changes from negative to positive at 7.77% and from positive to negative at 33.24%.

Is it reasonable to expect that a project's cash flows will experience only one sign change during its useful life? It depends on the type of project. For example, projects requiring environmental mitigation or significant retooling may have negative cash flows during the project's useful life.

FIGURE 15.4 The Case of Multiple IRRs

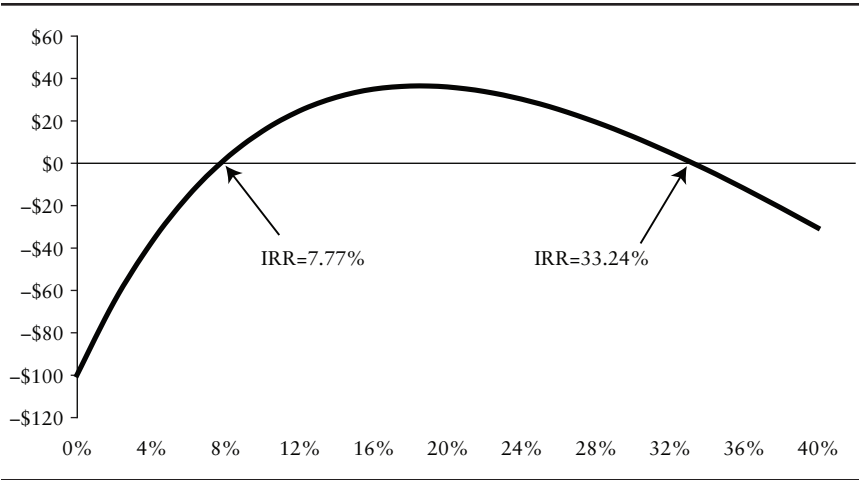

MODIFIED INTERNAL RATE OF RETURN

The *modified internal rate of return (MIRR)* is a yield on an investment considering a specific rate on the reinvestment of funds. The NPV method assumes that cash inflows from a project are reinvested at the project’s cost of capital, whereas the IRR method assumes that cash inflows are reinvested at the project’s IRR. These assumptions are built into the mathematics of the methods, but they may not represent the actual opportunities of the company. The modified IRR method is an alternative that considers a specific reinvestment rate for cash inflows from a project.

To better understand this reinvestment rate assumption, consider Project X. The IRR is 10.17188%. If each of the cash inflows from Project X is reinvested at 10.17188%, the sum of these future cash flows will be \$1,472,272.53 at the end of Year 4:

| Number of Periods Earning a Return | Future Value of Cash Flow Reinvested at 10.17188% |
|------------------------------------|---|
| 3 | \$0.00 |
| 2 | 242,756.88 |
| 1 | 330,515.65 |
| 0 | <u>900,000.00</u> |
| | <u>\$1,473,272.53</u> |

The \$1,473,272.53 is referred to as the project's *terminal value*.⁵ The terminal value is how much the company has from an investment if all proceeds are reinvested at the assumed reinvestment rate. In our illustration, we assumed the reinvestment rate is the IRR. So what is the return on this project? Using the terminal value as the future value and the investment as the present value,

$$\begin{aligned} \text{FV} &= \$1,473,272.53 \\ \text{PV} &= \$1,000,000.00 \\ N &= 4 \text{ years} \end{aligned}$$

$$r = \sqrt[4]{\frac{\$1,473,273}{\$1,000,000}} - 1 = 10.17188\%$$

In other words, investing \$1,000,000 at the end of Year 0 and receiving \$1,473,272.53 produces an average annual return of 10.1718%, which is the project's IRR.

Calculating the Modified Internal Rate of Return

The MIRR is the return on the project assuming reinvestment of the cash flows at a specified rate. Consider Project X if the reinvestment rate is 5%:

| Number of Periods Earning a Return | Future Value of Cash Flow Reinvested at 5% |
|---------------------------------------|---|
| 3 | \$0 |
| 2 | 220,500 |
| 1 | 315,000 |
| 0 | <u>900,000</u> |
| | \$1,435,500 |

The MIRR is 9.5962%:

$$\begin{aligned} \text{Terminal value} &= \$1,435,500 \\ \text{Present value} &= \$1,000,000 \\ N &= 4 \text{ years} \end{aligned}$$

$$\text{MIRR} = \sqrt[4]{\frac{\$1,435,500}{\$1,000,000}} - 1 = 9.4588\%$$

If, instead, the reinvestment rate is 6%:

⁵ For example, Year 2's cash flow of \$200,000 is reinvested at 10.17188% for two years (that is, for Year 3 and Year 4), or $\$200,000 (1 + 0.1017188)^2 = \$242,756.88$.

| Number of Periods Earning a Return | Future Value of Cash Flow Reinvested at 6% |
|------------------------------------|--|
| 3 | \$0 |
| 2 | 224,720 |
| 1 | 318,000 |
| 0 | 900,000 |
| | \$1,442,720 |

The MIRR is 9.4588%:

Terminal value = \$1,442,720

Present value = \$1,000,000

N = 4 years

$$\text{MIRR} = \sqrt[4]{\frac{\$1,442,720}{\$1,000,000}} - 1 = 9.5962\%$$

The opportunity of the company to reinvest the cash inflows at a higher rate (5% versus 6%) increases the attractiveness of the project, from an MIRR of 9.4588% to 9.5962%.

The MIRR is therefore a function of both the reinvestment rate and the pattern of cash flows, with higher reinvestment rates leading to greater MIRRs. Shown in Figure 15.5 are the MIRRs of both Project X and Project Y plotted for different reinvestment rates. Project Y's MIRR is more sensitive to the reinvestment rate because more of its cash flows are received sooner relative to Project X's cash flows.

FIGURE 15.5 MIRRs for Project X and Project Y

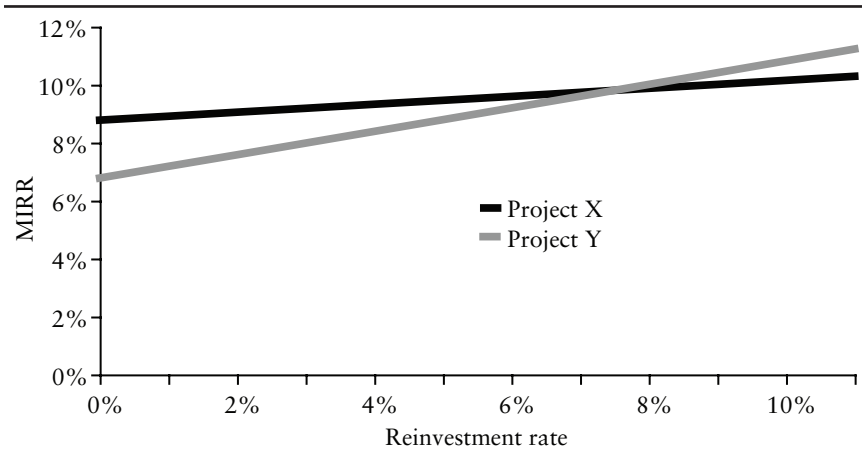

Representing this technique in a formula,

$$\text{MIRR} = \sqrt[N]{\frac{\sum_{t=1}^N \text{CIF}_t (1+i)^{N-t}}{\sum_{t=1}^N \frac{\text{COF}_t}{(1+i)^t}}$$

where the CIF_t are the cash inflows and the COF_t are the cash outflows. In the previous example, the present value of the cash outflows is equal to the \$1,000,000 initial cash outlay, whereas the future value of the cash inflows is \$1,435,500.

The decision rule for the modified internal rate of return is to invest in a project if it provides a return greater than the cost of capital. The cost of capital, in the context of the MIRR, is a hurdle rate—the minimum acceptable rate of return. For independent projects and situations in which there is no capital rationing, then

| If... | this means that... | and you... |
|---------------------------|---|---|
| MIRR > cost of capital | the investment is expected to return more than required | should accept the project. |
| MIRR < cost of capital | the investment is expected to return less than required | should reject the project. |
| MIRR = cost of capital | the investment is expected to return what is required | are indifferent between accepting or rejecting the project. |

PAYBACK PERIOD

The *payback period* for a project is the time from the initial cash outflow to invest in it until the time when its cash inflows add up to the initial cash outflow—in other words, how long it takes to recover the initial cash outflow. The payback period is also referred to as the *payoff period* or the *capital recovery period*. If \$10 million is invested today and the investment is expected to generate \$5 million one year from today and \$5 million two years from today, the payback period is two years—it takes two years to recoup the \$10 million investment.

Suppose a company is considering Projects X and Y each requiring an investment of \$1 million today (consider today to be the last day of Year 0) and promising cash flows at the end of each of the following years through Year 4. How long does it take to recover the \$1,000,000 investment? The payback period for Project X is four years:

| Year | Project X | Accumulated Cash Flows |
|------|--------------|------------------------|
| 0 | -\$1,000,000 | |
| 1 | \$0 | -\$1,000,000 |
| 2 | 200,000 | -800,000 |
| 3 | 300,000 | -500,000 |
| 4 | 900,000 | +400,000 |

By the end of Year 3, the entire \$1 million is not paid back, but by Year 4 the accumulated cash flow hits (and exceeds) \$1 million. Therefore, the payback period for Project X is four years. The payback period for Project Y is also four years. It is not until the end of Year 4 that the \$1 million initial investment (and more) is recovered.

Is Project X or Y more attractive? According to the payback period method, a shorter payback period is better than a longer payback period. Yet there is no clear-cut rule for how short is better. Assuming that all cash flows occur at the end of the year, Project X provides the same payback as Project Y. Therefore, the two projects cannot be distinguished from one another.⁶ In addition to having no well-defined decision criteria, payback period analysis favors investments with “front-loaded” cash flows: An investment looks better in terms of the payback period the sooner its cash flows are received no matter what its later cash flows look like.

Payback period analysis is a type of *break-even* measure. It tends to provide a measure of the economic life of the investment in terms of its payback period. The more likely the life exceeds the payback period, the more attractive the investment. The economic life beyond the payback period is referred to as the *post-payback duration*. If post-payback duration is zero, the investment is worthless, no matter how short the payback. This is because the sum of the future cash flows is no greater than the initial investment outlay. And since these future cash flows are really worth less today than in the future, a zero post-payback duration means that the present value of the future cash flows is less than the project’s initial investment.

⁶ Up to now, the cash flows are assumed to be received at the end of the year. Therefore, the resultant payback period is in terms of a whole number of years. If cash flows are assumed to be received, say, uniformly, such as monthly or weekly, throughout the year, the payback period is in terms of years and fractions of years. For example, assuming the cash flows from Project X are received uniformly throughout the year, the payback period for this project is 3 years and 6.6 months (assuming \$75,000 cash flow per month). The assumption of end-of-period cash flows may be unrealistic, but it is convenient to use this assumption to demonstrate how to use the various evaluation techniques. This end-of-period assumption is used throughout the coverage of capital budgeting techniques.

The payback method should be used only as a coarse initial screen of investment projects. But it can be a useful indicator of some things. Because a dollar of cash flow in the early years is worth more than a dollar of cash flow in later years, the payback period method provides a simple, yet crude measure of the liquidity of the investment.

The payback period also offers some indication of the risk of the investment. In industries where equipment becomes obsolete rapidly or where there are very competitive conditions, investments with earlier payback are more valuable. That's because cash flows farther into the future are more uncertain and therefore have lower present value. In the personal computer industry, for example, the fierce competition and rapidly changing technology requires investment in projects that have a payback of less than one year since there is no expectation of project benefits beyond one year.

Because the payback method does not indicate the particular payback period that maximizes wealth, it cannot be used as the primary screening device for investment in long-lived assets.

DISCOUNTED PAYBACK PERIOD

The *discounted payback period* is the time needed to pay back the original investment in terms of discounted future cash flows. In this technique, each cash flow is discounted back to the beginning of the investment at a rate that reflects both the time value of money and the uncertainty of the future cash flows.

Calculating the Discounted Payback Period

Returning to Projects X and Y, suppose that each has a cost of capital of 10%. The first step in determining the discounted payback period is to discount each year's cash flow to the beginning of the investment (the end of the Year 0) at the cost of capital. For example,

| Year | Project X | | Project Y | |
|------|-----------------|-----------------------------------|-----------------|-----------------------------------|
| | Cash Flows | Accumulated Discounted Cash Flows | Cash Flows | Accumulated Discounted Cash Flows |
| 0 | -\$1,000,000.00 | -\$1,000,000.00 | -\$1,000,000.00 | -\$1,000,000.00 |
| 1 | 0.00 | -1,000,000.00 | 295,454.55 | -704,545.45 |
| 2 | 165,289.26 | -834,710.74 | 268,595.04 | -435,950.41 |
| 3 | 225,394.44 | -609,316.30 | 244,177.31 | -191,773.10 |
| 4 | 614,712.11 | 5,395.81 | 221,979.37 | 30,206.27 |

How long does it take for each investment's discounted cash flows to pay back its \$1 million investment? The discounted payback period for both Projects X and Y is four years.

It appears that the shorter the payback period, the better, whether using discounted or nondiscounted cash flows. But how short is better? This is not clear. All that is known is that an investment *breaks even* in terms of discounted cash flows at the discounted payback period—the point in time when the accumulated discounted cash flows equal the amount of the investment.

Using the length of the payback as a basis for selecting investments, Projects X and Y cannot be distinguished. But by using the discounted payback period, valuable cash flows for both investments—those beyond what is necessary for recovering the initial cash outflow—are ignored. Therefore, the discounted payback period method is not recommended for evaluating capital projects.

ISSUES IN CAPITAL BUDGETING

Not all discounted cash flows methods are appropriate in all circumstances. As explained in this section, when faced with mutually exclusive projects, scale differences, different project lives, or capital rationing, care must be exercised in these circumstances.

Scale Differences

Scale differences between projects—that is, differences in the amount of the initial investment—can lead to conflicting investment decisions among the discounted cash flow techniques. Consider two projects, Project Bigger and Project Smaller, that each have a cost of capital of 5% per year with the following cash flows:

| End of Year | Cash Flows | |
|-------------|----------------|-----------------|
| | Project Bigger | Project Smaller |
| 0 | -\$5,000 | -\$2,500 |
| 1 | 1,250 | 650 |
| 2 | 1,250 | 650 |
| 3 | 1,250 | 650 |
| 4 | 1,250 | 650 |

Applying the discounted cash flow techniques to each project,

| Technique | Project Bigger | Project Smaller |
|-----------|----------------|-----------------|
| NPV | \$411.85 | \$314.16 |
| IRR | 7.93% | 9.43% |
| MIRR | 6.68% | 7.52% |
| PI | 1.08 | 1.13 |

If there is no limit to the capital budget—that is, there is no capital rationing—then both projects are acceptable, value-increasing projects as indicated by all four techniques. However, if the projects are mutually exclusive projects or there is a limit to the capital budget, then the four methods provide differing accept–reject decisions.

Mutually Exclusive Projects

If Project Bigger and Project Smaller are mutually exclusive projects, which project should a company prefer? If the company goes strictly by the PI, IRR, or MIRR criteria, it would choose Project Smaller. But is this the better project? Project Bigger provides more value—\$411.85 versus \$314.16. The techniques that ignore the scale of the investment—PI, IRR, and MIRR—may lead to an incorrect decision.

Capital Rationing

If the company is subject to capital rationing—say a limit of \$5,000—and the two projects are independent projects, which project should the company choose? The company can choose only one—spend \$2,500 or \$5,000, but not \$7,500. Applying the PI, IRR, or MIRR criteria, the company would choose Project Smaller. But is this the better project? Again, the techniques that ignore the scale of the investment—PI, IRR, and MIRR—lead to an incorrect decision.

Unequal Lives

If projects have unequal lives, the comparison strictly on the basis of these techniques may lead to an incorrect decision, whether choosing among mutually exclusive projects or subject to capital rationing. Consider the projects whose cash flows are provided in Figure 15.6. Project AA has a life of 5 years, Project BB a life of 10 years, and Project CC a life of 15 years. Projects AA and CC have a cost of capital of 4% and Project BB has a cost of capital of 5%.

FIGURE 15.6 Projects with Different Economic Lives

| Year | Projects' End-of-Year Cash Flows | | |
|------|----------------------------------|----------|----------|
| | AA | BB | CC |
| 0 | -\$1,000 | -\$1,000 | -\$1,000 |
| 1 | 260 | 160 | 120 |
| 2 | 260 | 160 | 120 |
| 3 | 260 | 160 | 120 |
| 4 | 260 | 160 | 120 |
| 5 | 260 | 160 | 120 |
| 6 | | 160 | 120 |
| 7 | | 160 | 120 |
| 8 | | 160 | 120 |
| 9 | | 160 | 120 |
| 10 | | 160 | 120 |
| 11 | | | 120 |
| 12 | | | 120 |
| 13 | | | 120 |
| 14 | | | 120 |
| 15 | | | 120 |

Applying the four discounted cash flow techniques without considering their different lives suggests that Project CC provides the most value added; Project CC produces the higher IRR benefit per \$1 invested.

| Technique | AA | BB | CC |
|-----------|----------|----------|----------|
| NPV | \$157.47 | \$235.48 | \$334.21 |
| IRR | 9.43% | 9.61% | 8.44% |
| MIRR | 7.09% | 7.24% | 6.02% |
| PI | 1.16 | 1.24 | 1.33 |

However, comparing these projects without any adjustment for the different lives ignores the fact that at the completion of the shorter projects, there is reinvestment necessary that is not reflected in the straightforward application of the techniques. In other words, this is an apples-to-oranges comparison if an adjustment is not made. One alternative is to find the common denominator life for the projects. In the case of these projects, this would be 30 years. This requires then looking at Project AA as reinvested in the same project five more times, resulting in a life for analysis of 30 years.

The common denominator approach may be cumbersome when there are many projects. An alternative is to use the *equivalent annual annuity* method. This method requires two steps:

Step 1: Calculate the annual annuity that is equivalent to the NPV of the project, considering the discount rate and the original life of the project. In the case of Project AA, the annuity amount is \$35.37.

Step 2: Calculate the present value of this annuity if received *ad infinitum*. In the case of Project AA, this is $\$35.37/0.04 = \884.32 .

The second step is necessary only if the comparison involves projects with different costs of capital. If the costs of capital are the same for the projects, the ranking of the projects in Step 1 is identical to that of Step 2. For the three projects,

| | Project | | |
|---------------------------|----------|----------|----------|
| | AA | BB | CC |
| Equivalent annual annuity | \$35.37 | \$30.50 | \$30.06 |
| Value in perpetuity | \$884.32 | \$609.91 | \$751.47 |

After adjusting for the different lives, the conclusion is that Project AA provides the most value added of the three projects.

COMPARING TECHNIQUES

When dealing with mutually exclusive projects, the NPV method leads us to invest in projects that maximize wealth, that is, capital budgeting decisions consistent with owners' wealth maximization. When dealing with a limit on the capital budget, the NPV and PI methods lead to the set of projects that maximize wealth.

The advantages and disadvantages of each of the techniques for evaluating investments are summarized in Table 15.2. As indicated in this table, the discounted cash flow techniques—NPV, IRR, PI, and MIRR—are preferred to the nondiscounted cash flow techniques because these techniques consider (1) all cash flows, (2) the time value of money, and (3) the risk of future cash flows. The discounted cash flow techniques are also useful because we can apply objective decision criteria—criteria can be used to estimate whether the projects are adding value.

However, not all discounted cash flow techniques are right for every situation. There are questions that must be asked when evaluating an investment and the answers will determine which technique is the one to use for that investment:

- Are the projects mutually exclusive or independent?
- Are the projects subject to capital rationing?
- Do the projects have the same risk?
- Do the projects have the same scale of investment?

TABLE 15.2 Advantages and Disadvantages to the Use of the Techniques

| Net Present Value | |
|---|--|
| Advantages | Disadvantages |
| <ol style="list-style-type: none"> 1. Tells whether the investment will increase the company's value. 2. Considers all the cash flows. 3. Considers the time value of money. 4. Considers the future cash flows' risk through the cost of capital. | <ol style="list-style-type: none"> 1. Requires an estimate of the cost of capital in order to calculate the net present value. 2. Expressed in terms of dollars, not as a percentage. |
| Profitability Index | |
| Advantages | Disadvantages |
| <ol style="list-style-type: none"> 1. Tells whether an investment increases the company's value. 2. Considers all cash flows of the project. 3. Considers the time value of money. 4. Considers the future cash flows' risk through the cost of capital. 5. Useful in ranking and selecting projects when capital is rationed. | <ol style="list-style-type: none"> 1. Requires an estimate of the cost of capital in order to calculate the profitability index. 2. May not give the correct decision when used to compare mutually exclusive projects. |
| Internal Rate of Return | |
| Advantages | Disadvantages |
| <ol style="list-style-type: none"> 1. Tells whether an investment increases the company's value. 2. Considers all cash flows of the project. 3. Considers the time value of money. 4. Considers the future cash flows' risk through the cost of capital in the decision rule. | <ol style="list-style-type: none"> 1. Requires an estimate of the cost of capital in order to make a decision. 2. May not give the value-maximizing decision when used to compare mutually exclusive projects. 3. May not give the value-maximizing decision when used to choose projects when there is capital rationing. 4. Cannot be used in situations in which the sign of the cash flows of a project change more than once during the project's life. |

TABLE 15.2 (Continued)

| Modified Internal Rate of Return | |
|---|---|
| Advantages | Disadvantages |
| <ol style="list-style-type: none"> 1. Tells whether an investment increases the company's value. 2. Considers all cash flows of the project. 3. Considers the time value of money. 4. Considers the future cash flows' risk through the cost of capital in the decision rule. | <ol style="list-style-type: none"> 1. Requires an estimate of the cost of capital in order to make a decision. 2. May not give the value-maximizing decision when used to compare mutually exclusive projects. 3. May not give the value-maximizing decision when used to choose projects when there is capital rationing. |
| Payback Period | |
| Advantages | Disadvantages |
| <ol style="list-style-type: none"> 1. Simple to compute. 2. Provides some information on the risk of the investment. 3. Provides a crude measure of liquidity. | <ol style="list-style-type: none"> 1. No concrete decision criteria to indicate whether an investment increases the company's value. 2. Ignores cash flows beyond the payback period. 3. Ignores the time value of money. 4. Ignores the future cash flows' risk. |
| Discounted Payback Period | |
| Advantages | Disadvantages |
| <ol style="list-style-type: none"> 1. Considers the time value of money. 2. Considers the project's cash flows' risk through the cost of capital. | <ol style="list-style-type: none"> 1. No concrete decision criteria that indicate whether the investment increases the company's value. 2. Requires an estimate of the cost of capital in order to calculate the payback. 3. Ignores cash flows beyond the discounted payback period. |

The advantages and disadvantages of each method are listed in Table 15.2. Here are some simple rules:

- If projects are independent and not subject to capital rationing, we can evaluate them and determine those projects that maximize wealth based on any of the discounted cash flow techniques.
- If the projects are mutually exclusive, have the same investment outlay, and have the same risk, we must use only the NPV or the MIRR techniques to determine the projects that maximize wealth.
- If projects are mutually exclusive and are of different risks or are of different scales, NPV is preferred over MIRR.

If the capital budget is limited, either the NPV or the PI can be used. The decision maker must be careful, however, not to select projects simply on the basis of their NPV or PI (that is, ranking on NPV and selecting the highest NPV projects), but rather according to how NPV of the total capital budget can be maximized. In other words, which set of capital projects will maximize owners' wealth?

CAPITAL BUDGETING TECHNIQUES IN PRACTICE

Among the evaluation techniques in this chapter, the one we can be sure about is the NPV method. This method will steer a CFO toward the project that maximizes wealth in the most general circumstances. But what evaluation technique is really used in practice?

What is known about what goes on in practice is from anecdotal evidence and surveys. Observations from these indicate:⁷

- Techniques that use discounted cash flows are preferred over techniques that fail to take into consideration the time value of money.
- There is an increased use of the net present value method.
- Most decision makers use more than one technique to evaluate the same projects, with a discounted cash flow technique used as a primary method and payback period used as a secondary method.
- The most commonly used technique is the net present value method, though the internal rate of return method is still widely used.

Up until recently, studies suggest that the IRR method was the most popular method, which was troublesome because it may lead to decisions about projects that are not in the best interest of owners in certain circumstances.⁸

Is the use of payback period also troublesome? Not necessarily. The payback period is generally used as a screening device for larger companies, eliminating those projects that cannot even break even. However, surveys

⁷ See, for example, Patricia Ryan and Glenn P. Ryan, "Capital Budgeting Practices of the Fortune 1000: How Have Things Changed?" *Journal of Business and Management* 8, no. 4 (Winter 2002), pp. 355–364 and John Graham and Campbell Harvey, "How Do CFOs Make Capital Budgeting and Capital Structure Decisions?" *Journal of Applied Corporate Finance* 15, no. 1 (Spring 2002), pp. 8–23.

⁸ For example, in a 1977 survey more than 50% of financial managers at major corporations used IRR as the primary method, whereas only 10% used NPV. See L. J. Gitman, and J.R. Forrester, Jr., "A Survey of Capital Budgeting Techniques Used by Major U.S. Firms," *Financial Management* 6 (1977), pp. 66–71.

suggest that smaller companies do rely on the payback method.⁹ Further, the payback period can be viewed as a measure of a yield. If the future cash flows are the same amount each period and if these future cash flows can be assumed to be received each period forever—essentially, a perpetuity—then $1/\text{payback period}$ is a rough guide to a yield on the investment.¹⁰ Use of the simpler techniques, such as payback period, does not mean that a company has unsophisticated capital budgeting.

Remember that evaluating the cash flows is only one aspect of the process:

- Cash flows must first be estimated.
- Cash flows are evaluated using NPV, PI, IRR, MIRR, or a payback method.
- Project risk must be assessed to determine the cost of capital.

The choice of the method used to evaluate the projects is just one of the many important decisions in the capital budgeting process.

CONFLICTS WITH RESPONSIBILITY CENTER PERFORMANCE EVALUATION MEASURES

In Chapter 12, we presented measures employed by corporations to evaluate the performance of managers of divisions and departments. The two measures are return on investment and residual income. While it is possible for a proposed project to be attractive on the basis of the capital budgeting techniques described in this chapter, still a division manager may reject it because the project would adversely affect the performance measure by which he is evaluated.

For example, suppose that a division manager is considering two mutually exclusive projects, Projects A and B. Project A has an expected life of five years and requires a cash outlay in the initial year. Project B has an expected life of 10 years and not only requires a larger investment outlay

⁹ Graham and Harvey, “How Do CFOs Make Capital Budgeting and Capital Structure Decisions?” p. 9. In this survey, the payback period method ranked fourth in terms of percentage of the CFOs who used this technique.

¹⁰ Suppose you invest \$100 today and expect \$20 each period, forever. The payback period is 5 years. The inverse, $1/5 = 20\%$ per year, is the yield on the investment. Now let's turn this relation around and create a payback period rule. Suppose we want a 10% per year return on our investment. This means that the payback period should be less than or equal to 10 years. So while the payback period may seem to be a rough guide, there is some rationale behind it.

in the initial year but there are also cash outlays in the following two years. Suppose further that, using all the capital budgeting techniques presented in this chapter, Project B is clearly superior to Project A. But Project B might typically have an adverse impact on the manager's performance in the first and second years compared to Project A. Thus, the division manager might bias the decision toward accepting Project A, the less attractive project.

Do companies actually consider reported financial results in capital investment decisions? The study by Campbell Harvey, John Graham, and Shivram Rajgopal provides evidence that managers may give up some economic value in order to meet reported earnings targets. Though the reasons are many, the primary reasons managers give for sacrificing cash flows in the interest of earnings are the perception of riskiness by investors, the predictability of earnings by investors, and the perception by customers that the company is stable.¹¹

Consequently, although the discounted cash flow techniques discussed in this chapter for evaluating investment proposals may be sound, the measures employed to evaluate individual managers may bias their decisions against the selection of the best projects. The goal is to establish measures to evaluate the performance of individual managers that are consistent with the techniques described in this chapter.

CAPITAL BUDGETING AND THE JUSTIFICATION OF NEW TECHNOLOGY

Although the “mechanics” of calculating the measures in this chapter given (1) the initial cash flows, (2) the cash flow from operations, and (3) the required return (or hurdle rate) are not complicated, remember that the most complex activity of the capital budgeting procedure is estimating cash flows.

Some observers of capital budgeting practices have cited examples of how capital budgeting techniques have not been properly utilized.¹² That is, despite the evidence that more firms are using NPV, that does not mean that the right decisions about investment opportunities are being made. The examples cited have focused on the failure of capital budgeting techniques to evaluate the acquisition of new technological equipment and information management projects.

When new technological equipment, such as a newly created computer-aided production process, is considered for acquisition, the cash flows must

¹¹ Campbell R. Harvey, John R. Graham and Shiva Rajgopal, “Value Destruction and Financial Reporting Decisions,” *Financial Analysts Journal*, forthcoming.

¹² One of the first is found in Robert H. Hayes and David Garvin, “Managing as if Tomorrow Mattered,” *Harvard Business Review* (May–June 1982), pp. 70–79.

be estimated. Does management do a good job of estimating the potential benefits from such technologies? Informed observers believe that this may not be the case despite the widespread use of capital budgeting techniques. For example, a survey conducted as part of a Boston University Roundtable almost 20 years ago found that 78% of the respondents felt that: “Most businesses in the U.S. will remain so tied to traditional quantitative investment criteria that they will be unable to properly evaluate the potential of computer-aided manufacturing options.”¹³ Despite the passing of time since this survey, observers believe that the situation has not improved.

It has been observed that those making capital budgeting decisions fail to (or refuse to) take into consideration critical factors that may improve future cash flow as a result of the introduction of a new technology. Keep in mind, this is not simply replacing one type of equipment with a technologically slightly superior one. Rather, the focus here is on new technologies that will significantly alter the production process. Not only is the impact on the future cost structure of the firm important, but the potential impact on its competitive position—domestic and global—must be assessed.

Underestimating the potential benefits when projecting cash flows results in a bias in favor of rejecting a new technology. But there are more problems. The estimated cash flows must be discounted. In the experience of the authors, it is not uncommon for firms to select a very high required return to evaluate new technologies. Of course, there is nothing wrong with using a high required return if the analysis as described earlier in this chapter demonstrates that such a return is warranted.¹⁴ However, for some firms the analysis underlying the setting of a high required rate ranges from little to none; or, put another way, for some firms the high required rate is arbitrarily determined.

Why does a high required return (or, equivalently, discount rate or hurdle rate) bias the acceptance of new technologies? Recall our old friend the time value of money. We know that the further into the future the positive cash flows, the lower will be all of the discounted flow measures we described in this chapter. We also know that the higher the discount rate the lower the NPV and profitability index. (In the case of the IRR, it will have to exceed the high hurdle rate.) Now consider a typical new technology that is being considered by a firm. It may take one or more years to get the

¹³ As cited in Robert S. Kaplan and Anthony A. Atkinson, *Advanced Management Accounting* (Englewood Cliffs, NJ: Prentice Hall, 1989), p. 474.

¹⁴ There is nothing wrong with assigning a high discount rate to a project involving new technologies, but, as we discuss in the next chapter, this discount rate should reflect the project's risk, considering the benefits that the project may provide in terms of diversification. If the project has high stand-alone risk but low risk once the project is viewed in terms of the entire company as a portfolio of projects, a high discount rate is not justified.

new technology up and running. Consequently, positive cash flow may not be seen for several years. A high discount rate coupled with positive cash flows not coming in for several years will bias the decision in the direction of rejecting a new technology. For example, suppose a discount rate of 22% is required on a project and that a positive cash flow is not realized for at least four years. Then the present value of a positive cash flow of \$1 four years from now at 22% is \$0.45; for a positive cash flow of \$1, 10 years from now, the present value is \$0.14. However, if the correct discount rate is, say, 13%, then the present value of a \$1 positive cash flow would be \$0.61 if it is received four years from now and \$0.29 if it is received 10 years from now. You can see the dramatic impact of an unwarranted high discount rate. Add to this the underestimation of the positive cash flows by not properly capturing all the benefits from the introduction of a new technology, and you can see why U.S. firms may have been reluctant to acquire new technologies using state-of-the-art capital budgeting techniques. Is it any wonder that respondents to a study conducted by the Automation Forum found that the financial justification of automated equipment was the number-one impediment to its introduction into U.S. firms two decades ago.¹⁵

In addition to the possible understatement of future cash flows or the overstatement of the discount rate associated with investment projects employing new technology, there is the potential problem of ignoring the real options that are present in these types of projects. A *real option* is an option associated with an investment project that has value arising from the option the company possesses, for example, to defer investment in the project, abandon the project, or expand the project. It may be the case that the new technology that provides a comparative or competitive advantage is unique, patented technology. If this is the case, the company may have a real option to defer investment, which enhances the value of the project beyond the value attributed simply to discounted cash flows.¹⁶ According to survey evidence, less than 30% of CFOs incorporate the value of these real options in the capital budgeting decision.¹⁷ Real options are discussed in the next chapter.

All of this is not to say that the capital budgeting techniques described in this chapter should not be used to analyze whether to acquire new technologies. Quite the contrary. We believe that if properly employed—that is, good cash flow estimation capturing all the benefits and costs that can be

¹⁵ Sandra B. Dornan, “Justifying New Technologies,” *Production* (July 1987).

¹⁶ For an example of a real option analysis in the case of information technology, see Michel Benaroch and Robert J. Kaufman, “A Case for Using Real Options Pricing Analysis to Evaluate Information Technology Project Investments,” *Information Systems Research* 10, no. 1, (1999), pp. 70–86.

¹⁷ See Graham and Harvey, “How Do CFOs Make Capital Budgeting and Capital Structure Decisions?”

realized from introducing a new technology, and the proper estimation of an appropriate discount rate—these techniques can help identify opportunities available from new technologies.

In fact, because of the failure to recognize the wide-ranging impact of the acquisition of new technologies, the Garnter Group in the 1980s proposed the concept of *total cost ownership (TCO)*. This measure, sometimes also referred to as the *total cost of operation*, is used to evaluate the direct and indirect impact related to the acquisition of new capital investment, taking into account all economic costs beyond the purchase cost and all the potential benefits. These economic costs include in addition to the acquisition costs changes in operating costs, conversion costs, and the cost of training personnel on the new equipment. On the benefit side, avoiding the potential loss of reputation from say security breaches or an improved risk management system are recognized as well as any productivity or performance improvements. Basically, if all costs and benefits are properly accounted for in the capital budgeting framework set forth in this chapter and the previous one, the same conclusions about acquiring new technologies as obtained from TCO analysis will be reached. It has been the failure of those employing traditional capital budgeting to take into account the not-so-obvious costs/benefits of ownership in acquiring new equipment, particularly new technologies, that TCO highlights, making it a popular tool employed by decision makers.

Still, despite the best efforts of management, it may be difficult to quantify the value of new technology and therefore difficult to use traditional capital budgeting techniques or TCO. For example, in evaluating technologies for managing risk it is not simple to quantify the benefits. A 2003 Federal Bureau of Investigation (FBI) report based on a survey of 241 firms, for example, stated that three-quarters of the survey participants acknowledged financial loss from security breaches of different types. However, of those firms that acknowledged losses, only 47% could quantify the loss.¹⁸

One approach to deal with acquisitions when financial measures are difficult to quantify that gives recognition to important factors other than cash flows is the balanced scorecard approach discussed in Chapter 6. Another approach to deal with the competitive impact of capital budgeting decisions is the treatment of these decisions within the context of option theory. This topic of *real options* in capital budgeting is covered in the next chapter.

¹⁸ “2003 CSI/FBI Computer Crime and Security Survey,” Computer Security Institute, 2003, p. 20.

BOTTOM LINE

- The six most commonly used techniques for evaluating capital budgeting proposals are the net present value, profitability index, internal rate of return, modified internal rate of return, payback period, and discounted payback period.
- The net present value method and the profitability index are preferred methods because they consider all the project's cash flows, involve discounting (which considers the time value of money and risk), and are useful in cases in which projects are mutually exclusive.
- The net present value method produces an amount that is the expected value added from investing in a project. That is, the net present value is an estimate of the value added from an investment project.
- The profitability index produces an indexed value that is useful in ranking projects.
- The internal rate of return is the yield on the investment. It is the discount rate that causes the net present value to be equal to zero.
- The internal rate of return is hazardous to use when selecting among mutually exclusive projects or when there is a limit on capital spending.
- The modified internal rate of return is a yield on the investment, assuming that cash inflows are reinvested at some rate other than the internal rate of return. This method overcomes the problems associated with unrealistic reinvestment rate assumptions inherent with the internal rate of return method. However, this method is hazardous to use when selecting among mutually exclusive projects or when there is a limit on capital spending.
- The payback period and the discounted payback period methods provide some measure of the time it takes to recover the initial investment in a project. Both of these methods have limitations in that they fail to consider all cash flows from a project. Furthermore, there are no objective criteria that can be used to judge a project, except for the simple criterion that the project must pay back.
- Each technique offers some advantages and disadvantages. The discounted flow techniques—NPV, PI, IRR, and MIRR—are superior to the payback period and the discounted payback period.
- The CFO must be careful about the technique used when evaluating mutually exclusive projects or projects subject to capital rationing. The net present value method is consistent with owners' wealth maximization whether mutually exclusive projects are being evaluated or there is capital rationing.

- Not all discounted cash flow methods are appropriate in all circumstances. When faced with mutually exclusive projects, scale differences, different project lives, or capital rationing, care must be exercised in using the most appropriate method for these special cases.
- When there are scale differences, use the net present value.
- When evaluating projects that have different economics lives, the different lives before selecting projects must be taken into account.
- Capital budgeting techniques may conflict with the measures used to evaluate the performance of responsibility managers.
- While capital budgeting techniques are used to evaluate the acquisition of new technologies, there are biases introduced. Specifically, the potential wide-ranging cash flow consequences are not always recognized, and unwarranted high required returns are set.

Capital Budgeting and Risk

AGENDA

- Item 1* Identify the relevant risk for evaluating a capital project.
- Item 2* Explain project risk using statistical measures.
- Item 3* Describe the different types of project risk.
- Item 4* Explain how to calculate a project's market risk.
- Item 5* Estimate a project's risk using the pure-play method.
- Item 6* Apply the capital asset pricing model to estimate a project's cost of capital.
- Item 7* Describe the adjusted present value method and the reasons for its use in evaluating capital projects.
- Item 8* Summarize the real options approach to the valuation of capital projects and compare this approach to the traditional capital budgeting methods.
- Item 9* Describe the certainty equivalent approach for dealing with risk in capital budgeting.
- Item 10* Explain how project risk is handled in practice.

The capital budgeting decisions that a CFO makes require analyzing for each potential project (1) its future cash flows, (2) the uncertainty with its future cash flows, and (3) the value of the future cash flows. When looking at the available investment opportunities, the CFO must determine the project or set of projects that is expected to add the most value to the company. This requires evaluating how each project's benefits compare with its costs. The projects that are expected to increase owners' wealth the most are the best ones. In weighing a project's benefits and its costs, the costs include both the cash flow necessary to make the investment (the investment outlay) and the opportunity costs of not using the cash tied up in this investment.

The benefits are the future cash flows generated by the investment. But nothing in the future is certain, so there is risk associated with the future cash flows. Therefore, for an evaluation of any investment to be meaningful, the CFO must represent how much risk there is that its cash flows will differ from what is expected in terms of both the amount and the timing of the cash flows.

Risk is the degree of uncertainty. Risk is typically incorporated in one of two ways:

1. Discount future cash flows using a higher discount rate, the greater the cash flow's risk.
2. Require a higher return on a project, the greater the cash flow's risk.

And, of course, risk is incorporated into the decision making regarding projects that maximize owners' wealth. In this chapter, the sources of cash flow uncertainty and how to incorporate risk in the capital budgeting decision are examined. In the next section, risk in the context of long-lived projects is discussed. Following this, several commonly used statistical measures of capital project risk are examined. Finally, methods of incorporating risk in the capital budgeting decision and how it is applied in practice are provided.

PROJECT RISK

When a CFO or the CFO's staff estimates what it costs to invest in a given project and what benefits are expected from the project in the future, they are faced with uncertainty. The uncertainty arises from different sources, depending on the type of investment being considered, as well as the circumstances and the industry in which the company is operating. Uncertainty may arise from many sources, including:

- *Economic conditions:* Will consumers be spending or saving? Will the economy be in a recession? Will the government stimulate spending? What will be the rate of inflation?
- *Market conditions:* Is the market competitive? How long does it take competitors to enter into the market? Are there any barriers, such as patents or trademarks, that will keep competitors away? Is there sufficient supply of raw materials and labor? How much will raw materials and labor cost in the future?
- *Interest rates:* What will be the cost of raising capital in future years?
- *Taxes:* What will tax rates be? Will Congress alter the tax system?
- *International conditions:* Will the exchange rate between different countries' currencies where the company transacts change? Are the governments of the countries in which the company does business stable?

These sources of uncertainty influence future cash flows and their risk. To evaluate and select among projects that will maximize owners' wealth, the CFO must assess the uncertainty associated with a project's cash flows.

CFOs worry about risk because the suppliers of capital—the creditors and owners—demand compensation for taking on risk. They can either provide their funds to the company to make investments or they could invest their funds elsewhere. Therefore, there is an opportunity cost to consider: what the suppliers of capital could earn elsewhere for the same level of risk. This return required by the suppliers of capital is the *required rate of return*, which comprises the compensation to suppliers of capital for their opportunity cost of not having the funds available (the time value of money) and compensation for risk:

$$\begin{aligned} \text{Cost of capital} = \\ \text{Compensation for the time value of money} + \text{Compensation for risk} \end{aligned}$$

Using the net present value criterion, if the present value of the future cash flows is greater than the present value of the cost of the project, it is expected to increase the value of the company, and therefore is acceptable. If the present value of the future cash flows is less than the present value of the costs of the project, it should be rejected. And under certain circumstances, using the internal rate of return criterion, if the project's return exceeds the project's cost of capital, the project increases owners' wealth. From the perspective of the company, this required rate of return is what it costs to raise capital and, hence, referred to as the *cost of capital*.

The compensation for risk is a risk premium—the additional return necessary to compensate investors for the risk they bear. How much compensation for risk is enough? 2%? 4%? 10%?

How does a CFO assess the risk of a project? The assets of a company are the result of its prior investment decisions. What this means is that the company is really a collection or portfolio of projects. So when the company adds another project to its portfolio, should the focus be only on the risk of that additional project? Or should the focus be the risk of the entire portfolio when the new project is included in it? There are different dimensions to the risk of a project.

Different Types of Project Risk

If the CFO has some idea of the uncertainty associated with a project's future cash flows—its possible outcomes—and the probabilities associated with these outcomes, then there is some measure of the risk of the project. But this is the project's risk in isolation from the company's other projects. This is the risk of the project ignoring the effects of diversification and is referred to as the project's *total risk* or *stand-alone risk*.

Because most companies have other assets, the stand-alone risk of the project under consideration may not be the relevant risk for analyzing the

project. A company is a portfolio of assets and the returns of these different assets do not necessarily move together; that is, they are not perfectly positively correlated with one another. We are therefore not concerned about the stand-alone risk of a project, but rather how the addition of the project to the company's portfolio of assets changes the risk of the company's portfolio.

Taking this a step further, consider that the shares of many companies may be owned by investors who themselves hold diversified portfolios. These investors are concerned about how the company's investments affect the risk of their own personal portfolios. When owners demand compensation for risk, they are requiring compensation for *market risk*, the risk they cannot diversify away. Recognizing this, a company considering taking on a new project should be concerned with how it changes the market risk of a company. Therefore, if the company's owners hold diversified investments—which is a safe assumption to make for all large corporations—it is the project's market risk that is relevant to the company's decision making.

Even though we generally believe that it is the project's market risk that is important to analyze, stand-alone risk should not be ignored. If we are making decisions for a small, closely held company, whose owners do not hold well-diversified portfolios, the stand-alone risk gives us a good idea of the project's risk. And many small businesses fit into this category.

Even if it is a large corporation making an investment decision, and that corporation has many products and whose owners are well-diversified, the analysis of stand-alone risk may be useful. Stand-alone risk is often closely related to market risk: In many cases, projects with higher stand-alone risk may also have higher market risk. And a project's stand-alone risk is easier to measure than market risk. A project's stand-alone risk may be gauged by evaluating the project's future cash flows using statistical measures, sensitivity analysis, and simulation analysis.

MEASUREMENT OF PROJECT RISK

In this section, three statistical measures are examined to evaluate the risk associated with a project's possible outcomes: the range, the standard deviation, and the coefficient of variation. Each is demonstrated using new products as examples.

Based on experience with the company's current product lines and the market research for new Product A, suppose that the product may generate one of three different cash flows in its first year, depending on economic conditions:

| Economic Condition | Cash Flow | Probability |
|--------------------|-----------|-------------|
| Boom | \$10,000 | 20% or 0.20 |
| Normal | 5,000 | 50% or 0.50 |
| Recession | -1,000 | 30% or 0.30 |

There are three possible outcomes, each representing a possible cash flow and its probability of occurring. Looking at this probability distribution, there is some chance of getting a $-\$1,000$ cash flow and some chance of getting a $+\$10,000$ cash flow, though the most likely possibility (the one with the greatest probability) is a $+\$5,000$ cash flow.

But to get an idea of Product A's risk, more is needed. The more dispersed the possible outcomes, the greater the degree of uncertainty (the risk) in future cash flows. The degree to which future outcomes differ from one another is the *dispersion* of the possible outcomes. In general, the greater the dispersion, the greater the risk. There are several measures used to describe the dispersion of future outcomes, including the range, the standard deviation, and the coefficient of variation.

Range

The *range* is a statistical measure representing how far apart the two extreme outcomes of the probability distribution are. The range is calculated as the difference between the best and the worst possible outcomes:

$$\text{Range} = \text{Best possible outcome} - \text{Worst possible outcome}$$

For Product A, the range of possible outcomes is $\$10,000 - (-\$1,000) = \$11,000$. The larger the range, the farther apart are the two extreme possible outcomes and therefore the greater the risk.

Standard Deviation

Though easy to calculate, the range does not reveal anything about the likelihood of the possible cash flows at or between the extremes. Typically in financial decision making, the focus is on not just the extreme outcomes, but all the possible outcomes.¹

One way to characterize the dispersion of all possible future outcomes is to look at how the outcomes differ from one another. This would require looking at the differences between all possible outcomes and trying to summarize these differences in a usable metric.

¹ In risk management, the extremes or *tails* are of critical importance.

An alternative to this is to look at how each possible future outcome differs from a single value, comparing each possible outcome with this one value. A common approach is to use a measure of central location of a probability distribution as the single value, the *expected value*.

Let's use N to designate the number of possible future outcomes, x_n to indicate the n th possible outcome, p_n to indicate the probability of the n th outcome occurring, and $E(x)$ to indicate the expected outcome. The expected cash flow is the weighted average of the cash flows, where the weights are the probabilities:

$$E(x) = x_1p_1 + x_2p_2 + x_3p_3 + \dots + x_np_n + \dots + x_Np_N$$

$$\text{Expected value} = E(x) = \sum_{n=1}^N p_n x_n$$

The *standard deviation* is a measure of how each possible outcome deviates—that is, differs—from the expected value. The standard deviation provides information about the dispersion of possible outcomes because it provides information on the distance each outcome is from the expected value and the likelihood the outcome will occur. The standard deviation is:

$$\text{Standard deviation of possible outcomes} = \sigma(x) = \sqrt{\sum_{n=1}^N p_n (x_n - E(x))^2}$$

To calculate the standard deviation, it is first necessary to calculate the expected outcome, $E(x)$. In the example, there are three possible outcomes, so $N = 3$. Adding the probability-weighted outcome of each of these three outcomes results in the expected cash flow:

$$\begin{aligned} E(\text{Cash flow for Product A}) &= (0.20)\$10,000 + (0.50)\$5,000 + (0.30)(-\$1,000) \\ &= \$2,000 + \$2,500 - \$300 \\ &= \$4,200 \end{aligned}$$

The calculations for the standard deviation are provided in Table 16.1. The standard deviation is a statistical measure of dispersion of the possible outcomes about the expected outcome. The larger the standard deviation, the greater the dispersion and, hence, the greater the risk.

Coefficient of Variation

The standard deviation provides a useful measure of dispersion. It is a measure of how widely dispersed the possible outcomes are from the expected

TABLE 16.1 Calculation of Expected Return and Standard Deviation for Product A

| Economic Conditions | Cash Flow | Probability | Cash Flow Times Probability | Deviation | Squared Deviation | Weighted Squared Deviation |
|---------------------|-----------|-------------|-----------------------------|-----------|-------------------|----------------------------|
| Boom | \$10,000 | 20% | \$2,000 | 5,800 | 33,640,000 | 6,728,000 |
| Normal | 5,000 | 50% | 2,500 | 800 | 640,000 | 320,000 |
| Recession | -1,000 | 30% | (300) | -5,200 | 27,040,000 | 2,112,000 |
| | | | $E(x) = \$4,200$ | | | $\sigma^2 = 15,160,000$ |
| | | | $\sigma = \$3,893.58$ | | | |

value. However, we cannot compare standard deviations of different projects' cash flows if they have different expected values.

The coefficient of variation, however, does consider the different expected value, translating the standard deviation of different probability distributions (because their scales differ) so that they can be compared.

The *coefficient of variation* for a probability distribution is the ratio of its standard deviation to its expected value:

$$\text{Coefficient of variation} = \text{Standard deviation/Expected value}$$

or

$$\text{Coefficient of variation} = \frac{\sigma_x}{\epsilon_x}$$

Risk can be expressed statistically in terms of measures such as the range, the standard deviation, and the coefficient of variation. Given the probability distributions of the project's future cash flows, these statistical tools can be applied to evaluate a project's risk.

How does the CFO or the CFO's staff arrive at these probability distributions? From research, judgment, and experience—for example, sensitivity analysis or simulation analysis using past experience of similar projects, if available, to get an idea of a project's possible future cash flows and their risk can be used.

Estimates of cash flows are based on assumptions about the economy, competitors, consumer tastes and preferences, construction costs, and taxes, among a host of other possible assumptions. One of the first things to consider about these estimates is how sensitive they are to these assumptions. For example, if the company sells only two million units instead of three million units in the first year, is the project still profitable? Or, if Congress increases the tax rates, will the project still be attractive?

Tools That Can Be Used to Evaluate Total Risk

The CFO can analyze the sensitivity of cash flows to change in the assumptions by reestimating the cash flows for different scenarios. *Sensitivity analysis* (also called *scenario analysis*) is the examination of possible cash flows and returns on an investment when one uncertain element is altered (that is, what-if? analysis).

Sensitivity analysis allows the CFO to examine the effects of changes in assumptions. But because sensitivity analysis focuses on only one change at a time or different sets of variations at a time, it is not very realistic. In real-

ity, many factors can change throughout the life of the project. In the case of the Williams project illustrated in Appendix B to Chapter 14, there are a number of assumptions built into the analysis that are based on uncertainty, including the sales prices of the building and equipment in five years and the entrance of competitors no sooner than five years. And you can use your imagination and envision any new product and the attendant uncertainties regarding many factors including the economy, the company's competitors, and the price and supply of raw material and labor.

Sensitivity analysis becomes unmanageable if we start changing two factors at the same time (change more than two and it's even worse). A manageable approach to changing two or more factors simultaneously is computer simulation. *Simulation analysis* can be used to analyze the cash flows and returns on investments when more than one uncertain element is considered (allowing more than one probability distribution to enter the picture). Simulation analysis allows the CFO to develop a probability distribution of possible outcomes, given a probability distribution for each variable that may change. Figure 16.1 provides an example of simulation analysis.

Simulation analysis is more realistic than sensitivity analysis because it introduces uncertainty for many variables in the analysis and takes into account the probability for each variable in the analysis. But this analysis may become complex since there are interdependencies among many variables in a given year and interdependencies among the variables in different time periods.

However, simulation analysis looks at a project in isolation, ignoring the diversification effects of projects, focusing instead on a single project's total risk. And simulation analysis also ignores the effects of diversification for the owners' personal portfolio. If owners hold diversified portfolios, then their concern is how a project affects their portfolio's risk, not the project's total risk.

MEASURING A PROJECT'S MARKET RISK

If an investor is looking at an investment in a share of stock, it is possible to look at that stock's returns and the returns of the entire market over the same period of time as a way of measuring its market risk. While this is not a perfect measurement, it at least provides an estimate of the sensitivity of that particular stock's returns as compared to the returns of the market as a whole. But what about the market risk of a new product? There is no way to look at how that new product has affected the company's stock return.

Though it is not possible to look at a project's returns and see how they relate to the returns on the market as a whole, we can do the next best thing:

FIGURE 16.1 Demonstration of Simulation Analysis

Suppose that a company is making an investment of \$80 million in the equipment for a new product. Through research obtained from the marketing and production management, the CFO’s staff has determined the expected price and cost per unit, as well as the number of units to produce and sell. Along with these estimates, the CFO’s staff has developed standard deviations from past experience that provide information on the uncertainty associated with these estimates.

For simplicity, assume that these three variables—price, cost, and number of units—are distributed normally with the mean and standard deviations provided by the company’s management. The company’s tax department has provided an estimate of the range of possible tax rates during the product’s life; in this example, a uniform distribution for these rates is assumed.

This analysis has produced the following:

| Variable | Number of Units | Price per Unit | Expense per Unit | | Tax Rate |
|--------------------|-----------------|----------------|------------------|---------|----------|
| Mean | 10,000,000 | \$14 | \$0.75 | Minimum | 35% |
| Standard deviation | 1,000,000 | \$2 | \$0.05 | Maximum | 45% |

Assuming that the product will be produced and sold for the foreseeable future and using Microsoft Excel®, 1,000 draws are simulated (that is, 1,000 random selections from each of the four variables’ distributions) using the above information. The product’s internal rate of return is calculated for each of these draws. The result is a distribution of possible internal rates of return for the product, as depicted in the histogram:

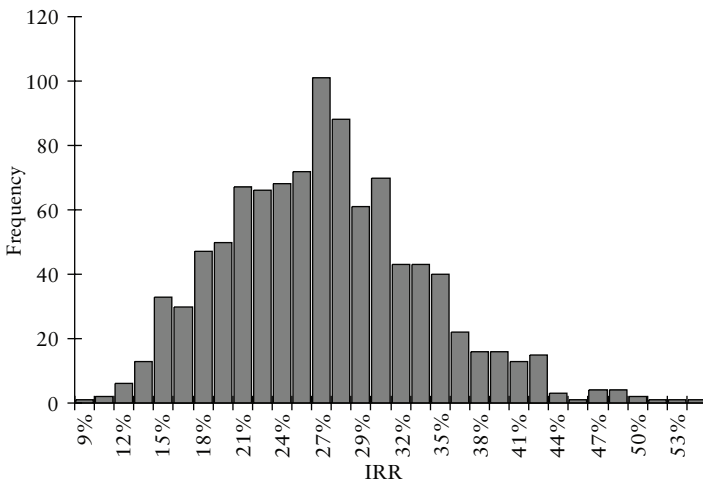

The height of this distribution is the number of draws (out of the possible 1,000 replications) for which the IRR fell into the range of IRRs depicted in the horizontal axis. In terms of risk, the wider the dispersion of possible IRRs relative to the expected IRR, the greater the product’s risk.

Estimate the market risk of the stock of another company whose only line of business is the same as the project's risk. If we could find such a company, we could look at its stock's market risk and use that as a first step in estimating the project's market risk.

In finance, the Greek letter beta, β , is typically used to denote a measure of market risk. β is a measure of the sensitivity of an asset's returns to change in the returns of the market. β is an elasticity measure: If the return on the market increases by 1%, the return on an asset with a β of 2.0 is expected to increase by about 2%; if the return on the market decreases by 1%, the return on an asset with a β of 1.5 is expected to decrease by about 1.5%, and so on. The *asset beta*, therefore, is a measure of the asset's market risk. To distinguish the beta of an asset from the beta we used for a company's stock, the asset's beta is denoted by β_{asset} and the beta of a company's stock by β_{equity} .

Market Risk and Financial Leverage

If a company has no debt, the market risk of its common stock is the same as the market risk of its assets. That is, the beta of its equity, β_{equity} , is the same as its asset's beta, β_{asset} . However, it is rarely the case that a company has no debt in its capital structure, so we must consider the effect of financial leverage on a company's equity beta.

Financial leverage is the use of debt obligations that require fixed contractual payments to finance a company's assets. The greater the use of debt obligations, the more financial leverage and the more risk associated with cash flows to owners. The effect of using debt is to increase the risk of the company's equity. If the company has debt obligations, the market risk of its common stock is greater than its assets' risk (that is, β_{equity} is greater than β_{asset}) due to financial leverage.

Consider an asset's beta, β_{asset} . This beta depends on the asset's risk, not on how the company chose to finance it. The CFO can choose to finance it with equity only, in which case β_{equity} is greater than β_{asset} . But what if, instead, the CFO chooses to finance it partly with a mixture of debt and equity? When this is done, the creditors and the owners share the risk of the asset, so the asset's risk is split between them, but not equally because of the nature of the claims. Creditors have seniority and receive a fixed amount (interest and principal), so there is less risk to the creditors compared to the owners associated with a dollar of debt financing than with a dollar of equity financing of the same asset. So the market risk borne by the creditors is different from the market risk borne by owners.

Representing the market risk of creditors as β_{debt} and the market risk of owners as β_{equity} , the asset's market risk is the weighted average of the

company's debt beta, β_{debt} , and equity beta, β_{equity} because the asset's risk is shared between creditors and owners. If the proportion of the company's capital from creditors is ω_{debt} and the proportion of the company's capital from owners is ω_{equity} , then:

$$\beta_{\text{asset}} = \beta_{\text{debt}} \left(\frac{\text{Proportion of assets financed with debt}}{\text{financed with debt}} \right) + \beta_{\text{equity}} \left(\frac{\text{Proportion of assets financed with equity}}{\text{financed with equity}} \right)$$

or

$$\beta_{\text{asset}} = \beta_{\text{debt}} \omega_{\text{debt}} + \beta_{\text{equity}} \omega_{\text{equity}}$$

But interest on debt is deducted to arrive at taxable income, so the claim that creditors have on the company's assets does not cost the company the full amount, but rather the after-tax claim, so the burden of debt financing is actually less due to interest deductibility. Further, the beta of debt is generally assumed to be zero (that is, there is no market risk associated with debt). With D representing the market value of debt, E representing the market value of equity, and τ the marginal tax rate, the relation between the asset beta and the equity beta is:

$$\beta_{\text{asset}} = \beta_{\text{debt}} \frac{(1-\tau)D}{[(1-\tau)D]+E} + \beta_{\text{equity}} \frac{E}{[(1-\tau)D]+E}$$

Assuming $\beta_{\text{debt}} = 0$,

$$\beta_{\text{asset}} = \beta_{\text{equity}} \frac{E}{[(1-\tau)D]+E}$$

Rearranging,

$$\beta_{\text{asset}} = \beta_{\text{equity}} \left[\frac{1}{\left(1 + (1-\tau) \frac{D}{E} \right)} \right]$$

This means that an asset's beta is related to the company's equity beta, with adjustments for financial leverage. If a company does not use debt, $\beta_{\text{equity}} = \beta_{\text{asset}}$, and if the company does use debt, $\beta_{\text{equity}} > \beta_{\text{asset}}$.

Therefore, a β_{equity} may be translated into a β_{asset} by removing the influence of the company's financial risk from β_{equity} . To accomplish this, the following must be known:

- The company's marginal tax rate.
- The amount of the company's debt financing in market value terms.
- The amount of the company's equity financing in market value terms.

The process of translating an equity beta into an asset beta is referred to as “unlevering” because the effects of financial leverage are removed from the equity beta, β_{equity} , to arrive at a beta for the company’s assets, β_{asset} . This beta therefore is an estimate of the market risk of a company’s assets.

Using a Pure-Play

There are many instances in which a company invests in assets with differing risks and a CFO is faced with estimating the cost of capital of a project. Using the company’s asset beta would be inappropriate because the asset beta reflects the market risk of all of the company’s assets and this may not be the same risk as for the project being evaluated. One approach to handle this dilemma is to estimate the cost of capital of a company that has a single line of business that is similar to the project under consideration.

A company with a single line of business is referred to as a *pure-play*. Selecting the company or companies that have a single line of business, where this line of business is similar to the project’s, helps in estimating the market risk of a project.

One method of estimating the pure-play’s equity beta is regressing the returns on the pure-play’s stock and the returns on the market. Once the pure-play’s equity beta is calculated, the CFO “unlevers” it by adjusting it for the financial leverage of the pure-play company.

Suppose a pure-play company has the following financial data:

$$\begin{aligned}\beta_{\text{equity}} &= 1.1 \\ \text{Tax rate} &= 0.34 \\ \text{Debt} &= \$3,914 \text{ million} \\ \text{Equity} &= \$4,468 \text{ million}\end{aligned}$$

Its asset beta, β_{asset} , is 0.6970:

$$\beta_{\text{asset}} = 1.1 \left[\frac{1}{\left(1 + \left((1 - 0.34) \frac{\$3,914}{\$4,468} \right) \right)} \right] = 0.6970$$

Because many U.S. corporations whose stock’s returns are readily available have more than one line of business, finding an appropriate pure-play company may be difficult. Care must be taken to identify those that have lines of business similar to the project’s. If an appropriate pure-play can be identified, this method can be used in estimating a project’s cost of capital.²

² Estimating a pure-play asset beta is useful in many other applications, including valuing divisions or segments of a business and valuing small businesses.

Adjusted Present Value

The use of the project's cost of capital to discount the cash flows of a project to the present is one method of incorporating the effect of financial leverage into the evaluation of a project. Another method is the *adjusted present value (APV)* method, which involves separating the value of the project and the value of the project's leverage.³ The basic expression of APV is:

$$\begin{aligned} & \text{Adjusted} \\ & \text{present value} \\ & = \text{Value of project if} \\ & \text{all-equity financed} + \underbrace{\left(\frac{\text{Value of the tax benefits from debt} - \text{PV of expected costs of financial distress}}{\text{PV of the project's financial leverage}} \right)}_{\uparrow} \end{aligned}$$

The value of the project if all-equity financed is the present value of the project's cash flows, discounted at a rate that reflects the asset's market risk.⁴ The value of the tax benefits from debt is the present value of the tax-shield from interest deductibility. For a given period, the tax shield is the product of the interest in that period and the marginal tax rate. The present value of the expected costs of financial distress is the present value of the probability-weighted costs of bankruptcy:

$$\text{PV of expected costs of financial distress} = \left(\frac{\text{Probability of financial distress}}{\text{financial distress}} \right) \times \left(\frac{\text{PV of the costs of financial distress}}{\text{financial distress}} \right)$$

Suppose the CFO is evaluating a project that has a required initial outlay of \$10 million and expected cash inflows of \$3 million for each of the next five years. And suppose that the marginal tax rate is 35%, and that the company's capital structure has a debt-equity ratio of 25%, a before-tax cost of debt of 5%, and a cost of equity of 9%. We calculate the cost of equity by using the following estimates: the company's stock beta of 1.5, an expected risk-free rate of interest of 3%, and a market risk premium of 4%.

A debt-equity ratio of 25% means that the company's capital structure consists of 20% debt and 80% equity.⁵ Using the weighted average cost of

³ The adjusted present value method is based on the work of Stewart Myers, "Interactions in Corporate Financing and Investment Decisions: Implications for Capital Budgeting," *Journal of Finance* 29 (March 1974), pp. 1–25.

⁴ Using the capital asset pricing model to determine the cost of capital for the all-equity financed project, the cost of capital is equal to the risk-free rate of interest plus the product of the market premium and the asset's beta. The product of the market premium and the asset's beta is the compensation for bearing risk.

⁵ The proportion of debt in the capital structure is calculated by dividing the debt-equity ratio by one plus the debt-equity ratio.

capital and the net present value method (NPV), the project's cost of capital is:

$$\text{Project's cost of capital} = [(0.20)(0.05)(1 - 0.4)] + [(0.80)(0.09)] = 7.8\%$$

The NPV of the project is therefore \$2.01415 million.

The APV of the project requires first calculating the value of the project if all-equity financed. The unlevered beta for the project—that is, the beta if the company was all-equity financed—is 1.304:

$$\beta_{\text{asset}} = 1.5 \left[\frac{1}{1 + [(1 - 0.40)0.25]} \right] = 1.0304$$

Therefore, the cost of equity is:

$$r_e = 0.03 + [1.0304 (0.04)] = 0.08217 \text{ or } 8.217\%$$

The value of the all-equity-financed project is calculated by discounting the project's cash flows at 8.217% and subtracting the cost of the project. The result is a value of the equity-financed project of \$1.9098 million.

The value of the tax shields requires first calculating the tax shield each period and discounting these at the before-tax cost of debt. If debt is 20% of the project's cost and the debt is constant through the life of the project at 20% of \$10 million, or \$2 million, the interest expense each year is 5% of \$2 million, or \$0.1 million. The tax shield each period is therefore 40% of \$0.1 million, or \$0.04 million. Discounting these tax shields at 5% produces a present value of the tax benefit from debt of \$0.1732 million.

Putting these two value pieces together produces:

$$\text{APV} = \$1.9098 \text{ million} + \$0.1732 \text{ million} = \$2.0830 \text{ million}$$

The NPV using the *weighted-average cost of capital* (WACC) is \$2.0415 million, which is less than the APV that we calculated of \$2.0830 million. Because we assumed a constant capital structure over the life of the project, the WACC and APV will differ in this example only because we incorporated financial leverage into the WACC for the NPV, but have not incorporated it in the APV as yet. If we back into the effect of financial distress, which is the only missing component in the APV, the PV of the costs of distress is

\$2.0830 million – \$2.0415 million = \$0.415 million.⁶ A challenge in using APV is that it is difficult to come up with the estimate of the likelihood and cost of financial distress.⁷

The difference between APV and NPV methods can be seen once it is assumed that the capital structure will change over the life of the project. If the NPV is calculated in the standard manner, using a WACC that does not change over the life of the project, this most likely will understate or overstate the value of the project if the capital structure changes. The only way to have equivalence between APV and the NPV in the case of a changing capital structure is to recalculate the WACC in the NPV method when the capital structure changes, which would be cumbersome. If, for example, the capital structure is expected to change each period, the WACC used for discounting the project cash flows must therefore change each period.

Extending this example to consider a changing capital structure, assume that the debt of \$2 million is paid off over the life of the project, with \$0.4 million of debt paid off each year. In this case, the interest expense, and hence tax shield, declines each year and the capital structure becomes less levered over the life of the project. We compare the NPV and the APV for the constant and declining capital structure scenarios in Table 16.2. In Panel A, the capital structure is constant and the difference between the NPV and the APV is the present value of financial distress, as discussed previously. In Panel B of this table, the APV is less than in Panel A because the present value of the tax shields is less. In this case, the difference between the NPV and the APV is not only the cost of financial distress, but also the effect of the changing capital structure (which changes the weights in the WACC and hence the NPV), which affects the value of the tax shields.⁸

The APV is easier to use relative to the NPV in the case of the changing capital structure because adjusting for the effects of the changing capital structure is less complex as summarized in Table 16.3.

⁶ If we assume that financial distress in this case is the loss of 100% of the equity value, the difference of \$0.0415 million implies a probability of distress of 2.17% since the cost of financial distress is the weight of distress applied against the possible loss, or 2.17% of \$1.9098 million = \$0.0415 million.

⁷ In some applications, the cost of financial distress is ignored if the company's capital structure is not believed to be sufficiently levered such that the costs of distress would be material.

⁸ Without a great deal more complexity, it is not possible to detail the effects on the capital structure and how the WACC must change to maintain equivalence to the APV and NPV. This is because not only do the weights in the WACC change, but also as the capital structure changes, the costs of debt and equity both change as well.

TABLE 16.2 NPV and APV

Panel A Constant capital structure

| In Millions | Year | | | | | |
|---------------------|------------|---------|---------|---------|---------|---------|
| | 0 | 1 | 2 | 3 | 4 | 5 |
| Project cash flow | \$(10.000) | \$3.000 | \$3.000 | \$3.000 | \$3.000 | \$3.000 |
| Debt principal | | \$2.000 | \$2.000 | \$2.000 | \$2.000 | \$2.000 |
| Interest on debt | | \$0.100 | \$0.100 | \$0.100 | \$0.100 | \$0.100 |
| Interest tax shield | | \$0.040 | \$0.040 | \$0.040 | \$0.040 | \$0.040 |

NPV if constant WACC = \$2.0415 million

APV components:

Value of all equity financed project = \$1.9098 million

Value of interest tax shields = 0.1732 million

APV without costs of financial distress = \$2.0830 million

Panel B Declining capital structure

Assuming that debt is paid off evenly throughout the life of the project and that the before-tax cost of debt declines uniformly from 5% to 4.6%.

| In Millions | Year | | | | | |
|-------------------------|------------|---------|---------|---------|---------|---------|
| | 0 | 1 | 2 | 3 | 4 | 5 |
| Project cash flow | \$(10.000) | \$3.000 | \$3.000 | \$3.000 | \$3.000 | \$3.000 |
| Debt principal | | \$2.000 | \$1.600 | \$1.200 | \$0.800 | \$0.400 |
| Interest on debt | | \$0.100 | \$0.080 | \$0.060 | \$0.040 | \$0.020 |
| Interest tax shield | | \$0.040 | \$0.032 | \$0.024 | \$0.016 | \$0.008 |
| Before-tax cost of debt | | 5.0% | 4.9% | 4.8% | 4.7% | 4.6% |

NPV if constant WACC = \$2.0415 million

APV components:

Value of all equity financed project = \$1.9098 million

Value of interest tax shields = 0.1077 million

APV without costs of financial distress = \$2.0185 million

TABLE 16.3 Capital Structure Change and APV versus NPV

| Capital Structure Change: | APV Is Affected Because: | NPV Is Affected Because: |
|---|--|---|
| Debt-equity declines over the life of the project. | <ul style="list-style-type: none"> ■ The before-tax cost of debt may decline.^a | <ul style="list-style-type: none"> ■ The before-tax cost of debt may decline. ■ The cost of equity may decline. ■ The weight assigned to debt decreases and the weight assigned to equity increases. |
| Debt-equity increases over the life of the project. | <ul style="list-style-type: none"> ■ The before-tax cost of debt may increase. | <ul style="list-style-type: none"> ■ The before-tax cost of debt may increase. ■ The cost of equity may increase. ■ The weight assigned to debt increases and the weight assigned to equity decreases. |

^a Hence, the present value of the tax shields is affected. Whether the present value of the tax shields increases or decreases depends on the rate of the decrease in the tax shields versus the decline in the cost of debt.

The NPV, however, has the distinct advantage over the APV of being simpler to use when the capital structure is assumed constant throughout the life of the project. In the case of the NPV, estimates of the costs and probability of financial distress are not necessary; rather the influence of the likelihood and cost of financial distress is already impounded in the costs of debt and the costs of equity and, hence, the WACC.

The challenge in using APV is that CFOs must specify the costs of financial distress and the probability, which are difficult to quantify. If the value effects of financial distress are ignored, the APV is overstated and, hence, the value added of the project is overstated. While it is difficult to specify the costs of financial distress, it should be noted that CFOs are being asked to try to assess the firm's risk appetite in order to implement integrated risk management as discussed in Chapter 8.

INCORPORATING RISK IN THE CAPITAL BUDGETING DECISION

Using the discounted cash flow capital budgeting techniques, the project's cost of capital used to evaluate a project should reflect the project's risk.

Risk-Adjusted Rate

The cost of capital is the cost of funds from the providers of capital, creditors and owners. This cost is the return required by these suppliers of capital. The greater the risk of a project, the greater the return required and, hence, the greater the cost of capital.

One view of the project's cost of capital is that it is the sum of what suppliers of capital demand for providing funds, which is comprised of two parts:

1. The return if the project were risk-free, which provides compensation for the time value of money.
2. The compensation for risk.

The compensation for the time value of money includes compensation for any anticipated inflation. The risk-free rate of interest, such as the yield on a long-term U.S. Treasury bond, is typically used to represent the time value of money. The compensation for risk is the extra return required because the project's future cash flows are uncertain. Because the relevant risk is the project's market risk, investors should require a greater return, the greater the project's market risk.

Project's Cost of Capital Based on the CAPM Method

A commonly used method of estimating a project's cost of capital is to use the return formula from the *capital asset pricing model (CAPM)*. This requires first specifying the premium for bearing the average amount of risk for the market as a whole and then, using a measure of market risk, fine tuning this to reflect the market risk of the project. The *market risk premium* for the market as a whole is the difference between the average expected market return, r_m , and the expected risk-free rate of interest, r_f . If a company buys an asset whose market risk was the same as that of the market as a whole, the company expects a return of $r_m - r_f$ to compensate investors for market risk.

Adjusting the market risk premium for the market risk of the particular project requires multiplying the market risk premium by that project's asset beta, β_{asset} :

$$\text{Compensation for market risk} = \beta_{\text{asset}}(r_m - r_f)$$

This is the extra return necessary to compensate for the project's market risk. The asset beta fine-tunes the risk premium for the market as a whole to reflect the market risk of the particular project. If we then add the risk-free interest rate, we arrive at the cost of capital:

$$\text{Cost of capital} = r_f + \beta_{\text{asset}}(r_m - r_f)$$

Suppose the expected risk-free rate of interest is 4% and the expected return on the market as a whole is 10%. If the β_{asset} is 2, this means that if there is a 1% change in the market risk premium, a 2% change in the return on the project is expected. In this case, the cost of capital is 16%:

$$\text{Cost of capital} = 0.04 + 2(0.10 - 0.04) = 0.16 \text{ or } 16\%$$

If instead the β_{asset} is 0.75, the cost of capital is 8.5%:

$$\text{Cost of capital} = 0.04 + 0.75(0.06) = 0.085 \text{ or } 8.5\%$$

The sensitivity of the estimate of the cost of capital is shown in Table 16.4 for β_{asset} of 2, 1.75, and 2.25, and for risk-free rates ranging from 2% to 5% and expected returns on the market ranging from 7% to 10%. Focusing on the β_{asset} of 2, the range of the cost of capital is from 12% to 15%. As this table illustrates, it is important to understand the sensitivity of the cost of capital to the estimated inputs.

Adjusting the Company's Cost of Capital

It is often the case that a CFO is not able to estimate the project's market risk, nor even the expected risk-free rate. Another way to estimate the cost of capital for a project without estimating the risk premium directly is to use the company's WACC as a starting point. The WACC is the company's marginal cost of raising one more dollar of capital—the cost of raising one more dollar in the context of all the company's projects considered altogether, not just the project being evaluated. The WACC of the company can then be adjusted to suit the perceived risk of the project:

- If a new project being considered is riskier than the average project of the company, the cost of capital of the new project is greater than the average cost of capital.
- If the new project is less risky, its cost of capital is less than the average cost of capital.
- If the new project is as risky as the average project of the company, the new project's cost of capital is equal to the average cost of capital.

However, altering the company's cost of capital to reflect a project's cost of capital requires judgment. How much do we adjust it? If the project is riskier than the typical project, do we add 2%? 4%? 10%? There is no

TABLE 16.4 Sensitivity of the Cost of Capital Estimate to the Inputs

| $\beta_{\text{asset}} = 2.0$ | | | | | | | |
|-------------------------------------|-------------------------------|-------|-------|-------|-------|-------|-------|
| Expected Risk-Free Interest Rate | Expected Return on the Market | | | | | | |
| | 7.0% | 7.5% | 8.0% | 8.5% | 9.0% | 9.5% | 10.0% |
| 2.0% | 12.0% | 13.0% | 14.0% | 15.0% | 16.0% | 17.0% | 18.0% |
| 2.5% | 11.5 | 12.5 | 13.5 | 14.5 | 15.5 | 16.5 | 17.5 |
| 3.0% | 11.0 | 12.0 | 13.0 | 14.0 | 15.0 | 16.0 | 17.0 |
| 3.5% | 10.5 | 11.5 | 12.5 | 13.5 | 14.5 | 15.5 | 16.5 |
| 4.0% | 10.0 | 11.0 | 12.0 | 13.0 | 14.0 | 15.0 | 16.0 |
| 4.5% | 9.5 | 10.5 | 11.5 | 12.5 | 13.5 | 14.5 | 15.5 |
| 5.0% | 9.0 | 10.0 | 11.0 | 12.0 | 13.0 | 14.0 | 15.0 |

| $\beta_{\text{asset}} = 1.75$ | | | | | | | |
|-------------------------------------|-------------------------------|-------|-------|-------|-------|-------|-------|
| Expected Risk-Free Interest Rate | Expected Return on the Market | | | | | | |
| | 7.0% | 7.5% | 8.0% | 8.5% | 9.0% | 9.5% | 10.0% |
| 2.0% | 10.8% | 11.6% | 12.5% | 13.4% | 14.3% | 15.1% | 16.0% |
| 2.5% | 10.4 | 11.3 | 12.1 | 13.0 | 13.9 | 14.8 | 15.6 |
| 3.0% | 10.0 | 10.9 | 11.8 | 12.6 | 13.5 | 14.4 | 15.3 |
| 3.5% | 9.6 | 10.5 | 11.4 | 12.3 | 13.1 | 14.0 | 14.9 |
| 4.0% | 9.3 | 10.1 | 11.0 | 11.9 | 12.8 | 13.6 | 14.5 |
| 4.5% | 8.9 | 9.8 | 10.6 | 11.5 | 12.4 | 13.3 | 14.1 |
| 5.0% | 8.5 | 9.4 | 10.3 | 11.1 | 12.0 | 12.9 | 13.8 |

| $\beta_{\text{asset}} = 2.25$ | | | | | | | |
|-------------------------------------|-------------------------------|-------|-------|-------|-------|-------|-------|
| Expected risk-free interest rate | Expected return on the market | | | | | | |
| | 7.0% | 7.5% | 8.0% | 8.5% | 9.0% | 9.5% | 10.0% |
| 2.0% | 13.3% | 14.4% | 15.5% | 16.6% | 17.8% | 18.9% | 20.0% |
| 2.5% | 12.6 | 13.8 | 14.9 | 16.0 | 17.1 | 18.3 | 19.4 |
| 3.0% | 12.0 | 13.1 | 14.3 | 15.4 | 16.5 | 17.6 | 18.8 |
| 3.5% | 11.4 | 12.5 | 13.6 | 14.8 | 15.9 | 17.0 | 18.1 |
| 4.0% | 10.8 | 11.9 | 13.0 | 14.1 | 15.3 | 16.4 | 17.5 |
| 4.5% | 10.1 | 11.3 | 12.4 | 13.5 | 14.6 | 15.8 | 16.9 |
| 5.0% | 9.5 | 10.6 | 11.8 | 12.9 | 14.0 | 15.1 | 16.3 |

prescription here. It depends on the judgment and experience of the decision maker. But this is where the measures of a project's stand-alone risk can be used to help form that judgment.

REAL OPTIONS

A significant challenge in capital budgeting is dealing with risk. The traditional methods of evaluating projects are being challenged by an alternative approach that applies option-pricing theory to real assets, referred to as *real options valuation (ROV)*. The interest in ROV arises from the fact that the traditional methods do not consider directly the options available in many investment projects. Though the importance of options in investment opportunities has long been recognized, it is only recently that a great deal of attention has been paid to incorporating options in a meaningful way.⁹

Consider the typical options inherent in an investment opportunity:

- Almost every project has an option to abandon, though there may be constraints (e.g., legally binding contracts) that affect when this option can be exercised.
- Many projects have the option to expand.
- Many projects have an option to defer investment, putting off the major investment outlays to some future date.

So how does the CFO consider these options within the context of the traditional methods? One approach is to use sensitivity analysis or simulation analysis. And while these analyses allow a look at the possible outcomes of a decision, they do not provide guidance regarding which course of action—of the many—to take. Another approach is the use of a decision tree analysis, associating probabilities to each of the possible outcomes for an event and mapping out the possible outcomes and the value of the investment opportunity associated with these different outcomes. And while this approach is workable when there are few options associated with a project, option pricing provides a method of analysis that is more comprehensive.

The basic idea of ROV is to consider that the value of a project extends beyond its value as measured by the net present value; in other words, the value of a project is supplemented by the value of the options. Because the options are considered strategic decisions, the revised or supplemented net present value is often referred to as the *strategic NPV*. Consider an invest-

⁹ For example, Stewart Myers recognized the importance of considering investment opportunities as growth options (“Determinants of Corporate Borrowing,” *Journal of Financial Economics* (Spring 1977), pp. 147–176).

ment opportunity that has one option associated with it. The strategic NPV is the sum of the traditional NPV (the static NPV)¹⁰ and the value of the option:

$$\text{Strategic NPV} = \text{Static NPV} + \text{Value of the option}$$

Options on Real Assets

The valuation of stock options is rather complex, but with the assistance of some well-accepted models such as the Black-Scholes model, the value of an option can be estimated. For example, in the Black-Scholes option-pricing model, there are five factors that are important in the valuation of an option:¹¹

1. The value of the underlying asset, P .
2. The exercise price or strike price of the option, E .
3. The short-term risk-free interest rate,¹² r_f .
4. The volatility of the value of the underlying asset, σ .
5. The time remaining to the expiration of the option, T .

The focus here is to map these factors onto a real asset option. As with other options, real options may be a *call option* (the option to buy an asset), a *put option* (the option to sell an asset), or a *compound option* (an option on an option). And, like other options, real options may have different exercise styles: a *European option* (an option that can be exercised only on the expiration date) or an *American option* (an option that can be exercised at any time on or before the expiration date).¹³

In general terms, the relation between the factors that affect the value of a stock option and those that affect a real option are shown in Table 16.5. Of course, the factors that correspond to a specific option can be better described when the individual option is examined.

Consider the option to abandon. In this case, the underlying asset is continuing operations and so the value of the underlying asset is the present

¹⁰ Dixit and Pindyck refer to the traditional NPV as *neoclassical NPV*. See Avinash K. Dixit and Robert S. Pindyck, *Investment Under Uncertainty* (Princeton, NJ: Princeton University Press, 1994).

¹¹ Fischer Black and Myron Scholes, "The Pricing of Options and Corporate Liabilities," *Journal of Political Economy* (May/June 1973), pp. 637–659.

¹² Note that unlike in the CAPM, in option pricing models the risk-free interest rate is a short-term interest such as the one-month London interbank offer rate (LIBOR).

¹³ An exercise style that allows the option to be exercised before the expiration date but only on designated dates is called a *Bermuda option*.

TABLE 16.5 Relation between Factors and the Value of an Option on a Stock and an Option on a Real Asset

| Parameter | Option on a Stock | Option on a Real Asset |
|-----------|---|---|
| X | The stock's price | The present value of cash flows from the investment opportunity |
| S | The exercise price of the option | The present value of the delayed capital expenditure or future cost savings |
| r | The risk-free rate of interest | The risk-free rate of interest |
| s | Volatility of value of the underlying asset | Uncertainty of the project's cash flows |
| t | The time to maturity | The project's useful life |

value of the cash flows associated with the asset. The *strike price* or *exercise price* for this option is the exit value or salvage value of the asset. A number of common real options are described in Table 16.6.¹⁴

Identifying the options associated with an investment opportunity is the first step. The second step is to value these options. Consider an investment opportunity to defer an investment. This investment opportunity is similar to what a company experiences in its investment in research and development: An expenditure or series of expenditures is made in research and development, and then, sometime in the future depending on the results of the research and development, the actions of competitors, and the approval of regulators, the company may then decide whether to go ahead with the investment opportunity.

Real Options: An Example

Putting numbers to the analysis of a project with a real option is helpful in explaining the valuation problem. Suppose that research and development is \$2 million initially and for each of the next three years. And suppose that at the end of the fourth year the company has an option to either go ahead with the product or simply abandon it. If the company goes ahead with the development of the product, this will require an investment of \$100 million at the end of the fourth year. To make the analysis simpler, assume that the

¹⁴ For a detailed discussion of real options, see Don M. Chance and Pamela Peterson, *Real Options and Investment Valuation* (Charlottesville, VA: Association for Investment Management and Research Educational Foundation, 2002) and William T. Moore, *Real Options and Option Embedded Securities* (Hoboken, NJ: John Wiley & Sons, 2001).

TABLE 16.6 Examples of Real Options

| Option | Type | Value of Underlying Asset | Exercise Price/Strike Price |
|------------------------------------|-----------------|---|---|
| To abandon | American put | The present value of the cash flows from the abandoned assets | The exit or salvage value |
| To defer an investment | American call | The present value of completed project's net operating cash flows | The deferred investment outlay |
| To abandon during construction | Compound option | The present value of the completed project's cash flows | The investment outlay necessary for the next stage |
| To contract the scale of a project | European put | The present value of potential cost savings | The costs of rescaling the project |
| To expand | European call | The present value of incremental net operating cash flows | The additional investment outlay |
| To switch inputs or outputs | American put | The present value of the incremental cash flows from the best alternative use | The cost of retooling production or distribution exercised at the expiration date |

Note: A put option is an option to sell the underlying asset; a call option is an option to buy the underlying asset. An American option is one that can be exercised at any time up to and including the expiration date; a European option is one that can only be exercised at the expiration date.

company can sell the investment in the product to another party—that is, cash out—at the end of the fourth year for \$120 million.¹⁵ And, because all of this is uncertain, the CFO must attach probabilities of this being a marketable product and, hence, one that the firm is able to cash out. Assume that there is a 60% chance that the company can cash out for \$120 million and a 40% chance that the company cannot cash out at all (and will, therefore, not make the investment).

Given this scenario, it means that:

- If the R&D is successful and the firm is able to cash out, the value at the end of the fourth year is \$120 million – \$100 million = \$20 million.

¹⁵ We are simplifying this example. More realistically, we would estimate future cash flows from the successful project beyond the fourth year and discount these to the end of the fourth year—and then use this value in place of the \$120 million.

- If the R&D is not successful and the firm is not able to cash out, the value at the end of the fourth year is zero.

Before the CFO can value the project with or without the option, an estimate of the project's cost of capital is required. As discussed earlier, the project's cost of capital is the sum of the risk-free interest rate and the risk premium that reflects the project's risk.¹⁶ In this application, the risk premium is determined relative to the market's risk premium. Suppose the risk-free interest rate is 5%, the market risk premium is 4%, and the volatility is 5 times that of the market. If the market's volatility (i.e., the standard deviation of expected cash flows) is 15%, the cost of capital is:¹⁷

$$\text{Cost of capital} = \text{Risk-free interest rate} + \text{Risk premium}$$

$$\text{Cost of capital} = 5\% + 5(4\%) = 25\%$$

Using a continuously compounded discount rate of 25%, the present value of the research and development costs is $-\$5.72$ million:

| | In Millions | | | |
|---|-------------|-----------|-----------|-----------|
| | 0 | 1 | 2 | 3 |
| Research and development | $-\$2.00$ | $-\$2.00$ | $-\$2.00$ | $-\$2.00$ |
| Present value of research and development | $-\$2.00$ | $-\$1.56$ | $-\$1.21$ | $-\$0.94$ |
| Total present value of R&D | $-\$5.72$ | | | |

Putting the R&D together with the value of the investment four years from today,

$$\begin{aligned} \text{NPV} &= -\$5.720 \text{ million} + \left\{ \left[(0.60) \frac{\$20 \text{ million}}{e^{4(0.25)}} \right] + [0.40(\$0)] \right\} \\ &= -\$5.720 \text{ million} + 4.415 \text{ million} \\ &= -\$1.305 \text{ million} \end{aligned}$$

This NPV represents the cost to the firm if the firm makes the decision today to commit to both the R&D and the investment at the end of the fourth year.

Using the traditional capital budgeting NPV technique, this suggests that the company should reject the project because its net present value is

¹⁶ To be consistent with the Black-Scholes option-pricing model, the continuously compounded cost of capital is used throughout the example.

¹⁷ This means that the volatility of the project's cash flows is $5(15\%) = 75\%$. This is the estimate of the volatility that is included in the valuation of the project's option.

negative. But wait—there is a valuable option of the deferred investment because the company can wait until the end of the fourth year to decide on the investment.

The value of the option is the estimate of how much value the option itself adds to the project. First, estimate the parameters of the option pricing model. Then we see how the value of the option, when considered along with the present value of the cost of acquiring the option (that is, the present value of the research and development), can make an unattractive project into an attractive project.

The value of the underlying asset is the discounted value of the probability-weighted possible outcomes:

$$\begin{aligned}\text{Value of the underlying asset} &= \left[(0.60) \frac{\$120 \text{ million}}{e^{4(0.25)}} \right] + [0.40(\$0)] \\ &= \$26.487 \text{ million}\end{aligned}$$

Therefore, the value of the parameters in the option valuation are as follows:

| | | |
|-------------------------------|---|------------------|
| Value of the underlying asset | = | \$26.487 million |
| Strike price | = | \$100 million |
| Risk-free rate of interest | = | 5% |
| Volatility | = | 75% |
| Number of years to exercise | = | 4 |

Using the Black-Scholes option pricing formula, the value of this option is \$7.774 million. Therefore, the value of the project is:

$$\begin{aligned}\text{Project NPV} &= \text{Present value of R\&D} + \text{Value of the option} \\ &= -\$5.72 \text{ million} + \$7.774 \text{ million} \\ &= \$2.054 \text{ million}\end{aligned}$$

Another way of looking at this is to estimate the *value-added of the deferral option* or (simply *value-added of the option*):

$$\text{Value-added of the option} = \text{Project NPV} - \text{Static NPV}$$

In our illustration:

$$\begin{aligned}\text{Value-added of the option} &= \$2.054 \text{ million} - (-\$1.305 \text{ million}) \\ &= \$0.749 \text{ million}\end{aligned}$$

Hence, the project has a positive NPV considering the valuable option to defer investment.

Challenges

This last example is simplified to illustrate the importance of considering options. There are, however, a number of challenges in incorporating real option valuation into an actual investment opportunity analysis.

The first challenge has to do with the parameters in the model. Focusing just on the estimate of volatility, the value-added of the option is sensitive to the estimate of volatility. It was simply assumed that the volatility is 50%; it is not a simple matter to determine the volatility of a project's future cash flow. This is a problem similar to trying to determine the beta of a project—it just is not measurable directly. The volatility of an investment opportunity's cash flows affects two key elements of the strategic value:

1. The volatility has a positive relation to the value of the option (that is, the greater the volatility, the greater the value of the option).
2. The volatility has a negative relation to the static NPV (that is, the greater the volatility, the greater the cost of capital and hence the lower the static NPV).

If we take this last example and calculate the strategic NPV with volatility of 60% and 90%, as well, we can see how the value of the option is affected by the choice of volatility:

| | Volatility | | |
|---------------------|------------|---------|---------|
| | 60% | 75% | 90% |
| Static NPV | -\$0.82 | -\$1.30 | -\$1.69 |
| Value of the option | \$0.47 | \$2.06 | \$3.14 |
| Strategic NPV | \$1.29 | \$3.36 | \$4.83 |

Second, most investment projects have several options, some of which interact. For example, if a firm is investing in R&D over a period of years in the development of a new product, there exists at least two options: the option to abandon during development and the option to defer investment. The valuation problem in the case of multiple options is not simply carried out by adding the separate values because the value of one option may affect the value of other options. Solving for the value of options in the case of

multiple, interacting options is beyond the Black and Scholes method and is quite difficult, requiring the application of numerical methods.¹⁸

Do companies actually evaluate real options in their capital budgeting decisions? It appears that real options have not caught on quite yet.¹⁹ Though many CFOs are aware of the concept of real options, there are a number of impediments to actually applying these. One drawback is that the mathematics behind options can be considered too much of a black box. Another is that a key parameter, volatility, is difficult to estimate. However, the concept of real options inherent in capital budgeting is attractive and this attractiveness may encourage companies to overcome these drawbacks.

CERTAINTY EQUIVALENTS

An alternative to adjusting the discount rate to reflect risk is to adjust the cash flow to reflect risk. We do this by converting each cash flow and its risk into its certainty equivalent. A *certainty equivalent* is the certain cash flow that is considered to be equivalent to the risky cash flow. For example, if the risky cash flow two years into the future is \$1.5 million, the certainty equivalent is the dollar amount of a certain cash flow (that is, a sure thing) that the firm considers to be worth the same. This certainty equivalent could be \$1 million, \$0.8 million, \$1.4 million, or any other amount—which depends on both the degree of risk of the \$1.5 million risky cash flow and the judgment of the decision maker.

The certainty equivalent approach of incorporating risk into the net present value analysis is useful for several reasons:

- *It separates the time value of money and risk.* Risk is accounted for in the adjusted cash flows while the time value of money is accounted for in the discount rate.
- *It allows each year's cash flows to be adjusted separately for risk.* This is accomplished by converting each year's cash flows into a certainty

¹⁸ For a discussion of these issues and an example of option interaction, see Lenos Trigeogis, "A Log-Transformed Binomial Numerical Analysis Method for Valuing Complex Multi-Option Investments," *Journal of Financial and Quantitative Analysis* (September 1991), pp. 309–326.

¹⁹ Edward Teach, "Will Real Options Take Root?" *CFO*, July 1, 2003. For another view of real options, see Ronald Fink "Reality Check for Real Options," *CFO*, September 1, 2001, in which the author argues that adopting real options requires substantial changes in the way companies view projects because the traditional NPV method views the project decision as accept/reject, whereas real options views the project as a web of options attached to the primary project, with decisions that extend beyond the initial accept/reject and may, in fact, involve abandonment.

equivalent for that year. The certainty equivalent factor may be different for each year.

- *The decision maker can incorporate preferences for risk.* This is done in determining the certainty equivalent cash flows.

However, there are some disadvantages to using the certainty equivalent approach that stymie its application in practice:

- *The net present value of the certainty equivalent is not easily interpreted.* We no longer have the clearer interpretation of the net present value as the increment in shareholder wealth.
- *There is no reliable way of determining the certainty equivalent value for each year's cash flow.*

ASSESSMENT OF PROJECT RISK IN PRACTICE

Most U.S. companies consider risk in some manner in evaluating investment projects. But considering risk is usually a subjective analysis as opposed to the more objective results obtainable with simulation or sensitivity analysis.

Surveys indicate that companies that use discounted cash flow techniques, such as net present value and internal rate of return methods, tend to use a risk-adjusted cost of capital, but generally use the company's weighted average cost of capital as a benchmark.²⁰ But a significant portion of companies use a single cost of capital for all projects, which can be problematic. Suppose a company uses the same cost of capital for all its projects. If all of them have the same risk and the cost of capital being used is appropriate for this level of risk, there is no problem. But what if a company uses the same cost of capital but the projects each have different levels of risk?

The company's cost of capital reflects the company's average risk project. What happens when this cost of capital is applied in discounted cash flow techniques, such as the net present value or the internal rate of return, to all projects? This will result in the company:

- Rejecting profitable projects (which would have increased owners' wealth) that have risk below the risk of the average risk project because the company has discounted the project's future cash flows too much.

²⁰ In the survey by Graham and Harvey, 60% of respondents claim to use a single, company-wide cost of capital, but then 51% claim to use some form of risk adjustment. See John Graham and Campbell Harvey, "How Do CFOs Make Capital Budgeting and Capital Structure Decisions?" *Journal of Applied Corporate Finance* 15, no. 1 (Spring 2002), pp. 8–23.

- Accepting unprofitable projects whose risk is above the risk of the average project, because the company did not discount the project's future cash flows enough.

The effect of the use of the single cost of capital is demonstrated in Table 16.7. Here, the use of the single discount rate results in a forgone opportunity (from the rejection of the lower risk project) and a value-destroying decision (the acceptance of a negative net present value project).

Companies that use a risk-adjusted discount rate usually do so by classifying projects into risk classes by the type of project. For example, a company with a cost of capital of 10% may use a 14% cost of capital for new products and a much lower rate of 8% for replacement projects. Given a set of costs of capital, the CFO need only figure out what class a project belongs to and then apply the rate assigned to that class.

Companies may also make adjustments in the cost of capital for factors other than the type of project. For example, companies investing in projects in foreign countries will sometimes make an adjustment for the additional risk of the foreign project, such as exchange rate risk, inflation risk, and political risk.

There are tools available to assist the decision maker in measuring and evaluating project risk. But much of what is actually done in practice is subjective. Judgment, with a large dose of experience, is used more often than scientific means of incorporating risk. Is this bad? Well, the scientific

TABLE 16.7 Project's Cost of Capital versus WACC

Consider three projects, each requiring an investment of \$1 million:

| | Projects | | |
|------------------------------------|-----------|-----------|-----------|
| | AAA | BBB | CCC |
| Project's cost of capital | 12% | 10% | 8% |
| NPV at project's cost of capital | -\$30,000 | +\$90,000 | \$30,000 |
| NPV at company's cost of capital | +\$10,000 | +\$90,000 | -\$20,000 |
| Decision | | | |
| Based on project's cost of capital | Reject | Accept | Accept |
| Based on company's cost of capital | Accept | Accept | Reject |

Assuming that each project is independent and there is no limit to the capital budget, projects BBB and CCC should be accepted. Therefore, the value added based on using projects' cost of capital is \$90,000.

If the company's cost of capital is used, then AAA is accepted when it should not have been (reducing the value of the company by \$30,000) and project CCC is rejected, when it could have been adding value of \$30,000.

approaches to measurement and evaluation of risk depend, in part, on subjective assessments of risk, the probability distributions of future cash flows, and judgments about market risk. So it is possible that bypassing the more technical analyses in favor of completely subjective assessment of risk may result in cost-of-capital estimates that better reflect the project's risk. But then again, it may not. The proof may be in the pudding, but it is difficult to assess the "proof" because it can never be determined how well a company may have done had it used more technical techniques.

BOTTOM LINE

- Evaluating capital projects requires assessing the risk associated with the future cash flows. This risk may be measured in terms of the stand-alone risk or the market risk, though in most cases the focus is on the project's market risk.
- The stand-alone risk of a project may be estimated using statistics that measure the dispersion of possible outcomes, such as the standard deviation and the coefficient of variation.
- Statistical measures that can be used to evaluate the risk of a project's cash flows are the range, the standard deviation, and the coefficient of variation.
- Sensitivity analysis and simulation analysis are tools that can be used in conjunction with statistical measures to evaluate a project's risk. Both techniques give an idea of the relation between a project's return and its risk. However, since the company is itself a portfolio of projects and it is typically assumed that owners hold diversified portfolios, the relevant risk of a project is not its stand-alone risk, but rather how it affects the risk of owners' portfolios, its market risk.
- Risk is typically incorporated into decision making by using a cost of capital that reflects the project's risk.
- The adjusted present value method is an alternative method for evaluating a capital project that incorporates the effect of financial leverage. The method involves separating the value of the project's financial leverage from the value of the project.
- The relevant risk for the evaluation of a project is the project's market risk, which is also referred to as the asset beta. This risk may be estimated by looking at the market risk of companies in a single line of business similar to that of the project, a pure-play.
- An alternative to finding a pure-play is to classify projects according to the type of project (e.g., expansion) and assign costs of capital to each project type according to subjective judgment of risk.

- Most companies adjust for risk in their assessment of the attractiveness of projects. However, this adjustment is typically accomplished by evaluating risk subjectively and ad-hoc adjustments to the company's cost of capital to arrive at a cost of capital for a particular project.
- Estimating the options associated with an investment opportunity may reveal value in a project that is not reflected using traditional capital budgeting techniques.
- There are options associated with every investment opportunity, including the option to defer the investment and the option to abandon the investment.
- The valuation of a single option is straightforward, but the valuation of multiple options that may interact is quite difficult.
- An alternative approach to dealing with risk in a capital project is through the use of certainty equivalents, which are risk-free values that correspond to the risky cash flows.

Leasing

AGENDA

- Item 1* Describe the different types of leases: nontax-oriented leases and tax-oriented leases.
- Item 2* Explain the different reasons typically offered for leasing and assess their validity.
- Item 3* Identify the different types of lease programs available to a company interested in leasing and the potential lessors.
- Item 4* Describe the financial reporting requirements for lessees.
- Item 5* Describe the federal income tax requirements for a lease to qualify as a true lease.
- Item 6* Explain the impact of FASB No. 13 on synthetic lease financing.
- Item 7* Describe an economic model for valuing a leasing: determining whether to lease or borrow to buy an asset.
- Item 8* Explain a leveraged lease and how it differs from a single-investor lease.

A lease is a contract over the term of which the owner of the property or equipment permits another entity to use it in exchange for a promise by the latter to make a series of payments. The owner of the equipment is referred to as the *lessor*. The entity that is being granted permission to use the equipment is referred to as the *lessee*.

CFOs recognize that earnings are derived from the use of an asset, not its ownership, and that leasing is simply an alternative financing method. More equipment is financed today by equipment leases than by bank loans, private placements, or any other method of equipment financing. Nearly any asset that can be purchased can also be leased, from aircraft, ships, satellites, computers, refineries, and steam-generating plants, on one hand, to typewriters, duplicating equipment, automobiles, and dairy cattle, on the other hand. According to the Equipment Leasing Association, of the \$850

billion spent in the United States on new productive equipment, about 27% was financed via leasing.

In order to compare leasing with other methods of financing, it is necessary to understand the basics of how leasing works and the differences among the general categories of equipment leases. This will be explained in this chapter, along with the reasons often cited for leasing, the types of lessors, and tax and financial reporting requirements. A framework for deciding whether to lease or borrow to buy is then presented. A special type of leasing arrangement used for leasing large-ticket items is leveraged leasing. The mechanics and issues associated with arranging a leveraged lease are explained in this chapter.

Leasing is more than a financing vehicle, so that is why we devote a good deal of space to a discussion of leasing. It can also be used by a company as a means to promote the sale of its products by allowing potential customers to finance the acquisition. Captive leasing companies are established by firms to do just that. In fact, firms have found financing their products via leasing a highly profitable business. Some firms have securitized their lease receivable portfolio as explained in Chapter 5. Moreover, some firms participate in the area of leveraged leasing as an equity investor in order to reduce their tax liability.

HOW LEASING WORKS

A typical leasing transaction works as follows: The lessee first decides on the equipment needed. The lessee then decides on the manufacturer, the make, and the model. The lessee specifies any special features desired, the terms of warranties, guaranties, delivery, installation, and services. The lessee also negotiates the price. After the equipment and terms have been specified and the sales contract negotiated, the lessee enters into a lease agreement with the lessor. The lessee negotiates with the lessor on the length of the lease; the rental; whether sales tax, delivery, and installation charges should be included in the lease; and other optional considerations.

After the lease has been signed, the lessee assigns its purchase rights to the lessor, which then buys the equipment exactly as specified by the lessee. When the equipment is delivered, the lessee formally accepts the equipment to make sure it gets exactly what was ordered. The lessor then pays for the equipment, and the lease goes into effect.

When all costs associated with the use of the equipment are to be paid by the lessee and not included in the lease payments, the lease is called a *net lease* or *triple-net lease*. Examples of such costs are property taxes, insurance, and maintenance. These costs are paid directly by the lessee and may not be deducted from the lease payments.

At the end of the lease term, the lessee usually has the option to renew the lease, to buy the equipment, or to terminate the agreement and return the equipment. As we shall see later in this chapter, the options available to the lessee at the end of the lease are very significant in that the dimensions of such options determine the nature of the lease for tax purposes and the classification of the lease for financial accounting purposes.

TYPES OF EQUIPMENT LEASES

Equipment leases fall into the following two general categories: (1) nontax-oriented leases and (2) tax-oriented true leases.¹

Nontax-Oriented Leases

Nontax-oriented leases, most commonly referred to as *conditional sale leases*, transfer substantially all of the benefits and risks incidental to ownership of the leased property to the lessee and usually give the lessee a fixed-price bargain purchase option or renewal option not based on fair market value at the time of exercise.

We discuss the guidelines under the Internal Revenue Code for a lease to be classified as a conditional sale lease for tax purposes later in this chapter. If a lease is classified as a conditional sale lease, the lessee treats the property as owned thereby entitling the lessee to depreciate the property for tax purposes, claim any tax credit that may be available, and deduct as an expense the imputed interest portion of the lease payments. The lessor under a conditional sale lease treats the transaction as a loan and cannot offer the low lease rates associated with a true lease because the lessor does not retain the tax benefits available to the owner of the equipment.

Tax-Oriented True Leases

The *true lease* offers all of the primary benefits commonly attributed to leasing. Substantial cost savings can often be achieved through the use of tax-oriented true leases in which the lessor claims and retains the tax benefits of ownership and passes through to the lessee a portion of such tax benefits in the form of reduced lease payments. The lessor claims tax benefits resulting from equipment ownership such as tax depreciation deductions, and the lessee deducts the full lease payment as an expense. The lessor in a true lease owns the leased equipment at the end of the lease term. A tax-oriented true

¹ There is a third type of specialized lease that is not discussed, a *tax-oriented TRAC lease for over-the-road vehicles*.

lease (also sometimes called a *guideline lease*) either contains no purchase option or has a purchase option based on fair market value.

The principal advantage to a lessee of using a true lease to finance an equipment acquisition is the economic benefit that comes from the indirect realization of tax benefits that might otherwise be lost because the lessee cannot use the tax benefits. This occurs when the lessee neither has a sufficient tax liability, nor expects to be able to fully use the tax benefits in the future if those benefits are carried forward.

If the lessee is unable to generate a sufficient tax liability to currently use all tax benefits, the cost of owning new equipment will be effectively higher than leasing the equipment under a true lease. Under these conditions, leasing is usually a less costly alternative than borrowing to buy because the lessor uses the tax benefits from the acquisition and passes on a portion of these benefits to the lessee through a lower lease payment.

The lower cost of leasing realized by a lessee throughout the lease term in a true lease must be weighed against the loss of the leased equipment's market value at the end of the lease term, referred to as the *residual value*. A framework for evaluating the tax and timing effects is presented later in this chapter.

The Internal Revenue Service is well aware that parties to a leasing transaction may find it more advantageous from a tax point of view to characterize an agreement as a "lease" rather than as a conditional sale agreement. Therefore, guidelines have been established by the IRS to distinguish between a true lease and a conditional sale agreement. These guidelines are discussed later.

Single-Investor Leases versus Leveraged Leases

There are two categories of true leases: single-investor leases (or direct leases) and leveraged leases. *Single-investor leases* are essentially two-party transactions, with the lessor purchasing the leased equipment with its own funds and being at risk for 100% of the funds used to purchase the equipment.

The leveraged form of a true lease of equipment is the ultimate form of lease financing. The most attractive feature of a *leveraged lease*, from the standpoint of a lessee unable to use the depreciation tax benefits, is its low cost as compared to alternative methods of financing. Leveraged leasing also satisfies a need for lease financing of especially large capital equipment projects with economic lives of up to 25 or more years, although leveraged leases are also used where the life of the equipment is considerably shorter. The leveraged lease can be a most advantageous financing device when used for the right kinds of projects and structured correctly.

A leveraged lease of equipment is conceptually similar to a single-investor lease. The lessee selects the equipment and negotiates the lease in much the same manner. Also, the terms for rentals, options, and responsibility for taxes, insurance, and maintenance are similar. However, a leveraged lease is appreciably more complex in size, documentation, legal involvement, and, most importantly, the number of parties involved and the unique advantages that each party gains.

Leveraged leases of equipment are generally offered only by corporations and financial institutions acting as lessors. This is because in a leveraged lease the tax benefits available to individual lessors are much more limited than those available to a corporation.

The lessor in a leveraged lease of equipment becomes the owner of the leased equipment by providing only a percentage (20% to 30%) of the capital necessary to purchase the equipment. The remainder of the capital (70% to 80%) is borrowed from institutional investors on a nonrecourse basis to the lessor. Such a loan is secured by a first lien on the equipment, an assignment of the lease, and an assignment of the lease payments. The cost of the nonrecourse borrowing is a function of the credit standing of the lessee. The lease rate varies with prevailing interest rates and with the risk of the transaction.

A “leveraged lease” is always a true lease. The lessor in a leveraged lease can claim all of the tax benefits incidental to ownership of the equipment even though the lessor provides only 20% to 30% of the capital needed to purchase the equipment. This ability to claim the tax benefits attributable to the entire cost of the leased equipment and the right to 100% of the residual value provided by the lease, while providing and being at risk for only a portion of the cost of the equipment, is the “leverage” in a leveraged lease. This leverage enables the lessor in a leveraged lease to offer the lessee much lower lease rates than the lessor could provide under a single-investor nonleveraged lease.

Single-investor nonleveraged leases are basically two-party transactions with a lessee and a lessor. However, leveraged leases by their nature involve a minimum of three parties with diverse interests: a lessee, a lessor, and a nonrecourse lender. Indeed, leveraged leases are sometimes called *three-party transactions*. We will discuss leveraged leases in more detail later in this chapter.

FULL-PAYOUT LEASES VERSUS OPERATING LEASES

Thus far, the leases we have discussed are comparable to equipment financing transactions in that the lease term is for a substantial portion of the

economic life of the leased equipment. In these leases the lessor expects to recover its entire investment plus (1) a targeted return on its investment from the lease payments received, (2) any tax benefits the lessor is entitled to receive, and (3) the residual value anticipated when the lease terminates. These types of leases are called *full-payout leases*. Such leases are essentially financing transactions.

Other types of leases, called *operating leases*, in contrast to full-payout lease, are not financing transactions. Operating leases may be for only a fraction of the life of the asset. An operating lease is always a true lease for tax purposes. That is, the lessor is entitled to all the tax benefits associated with ownership, and the lessee is entitled to deduct the lease payments.

We shall explain later in this chapter the special meaning of the term *operating lease* for financial accounting purposes. Transactions classified as operating leases are not disclosed in the body of the balance sheet as financial obligations.² Instead, they are shown in the footnotes to the financial statement as fixed obligations. This classification may arise despite the fact that the transaction, for all intents and purposes, is a financing transaction.³

REASONS FOR LEASING

Leasing is an alternative to purchasing. Because the lessee is obligated to make a series of payments, a lease arrangement resembles a debt contract. Thus, the advantages cited for leasing are often based on a comparison between leasing and purchasing using borrowed funds.

Cost

Many lessees find true leasing attractive because of its apparent low cost. This is particularly evident where a lessee cannot currently use tax benefits associated with equipment ownership due to such factors as lack of currently taxable income or net operating loss carryforwards.

² As of spring 2007, the accounting for leasing is such that the liability of operating leases is not provided in the balance sheet. However, the leasing project of the Financial Accounting Standards Board, jointly with the International Accounting Standards Board, is exploring the change in lease accounting that considers Section 401(c) of the Sarbanes-Oxley Act of 2002.

³ The most likely outcome of the current review of the accounting for leasing by FASB and IASB is that the assets and liabilities related to operating leases will be included in a company's balance sheet. This is not expected to alter companies' credit ratings because rating services generally estimate and include these assets and liabilities in evaluating a company's creditworthiness. (See Stephen Taub, "New Leasing Rules Could Add Assets," *CFO.com*, August 3, 2006.)

If it were not for the different tax treatment for owning and leasing equipment, the costs would be identical in an efficient capital market. However, due to the different tax treatment as well as the diverse abilities of taxable entities to currently utilize the tax benefits associated with ownership, no set rule can be offered as to whether borrowing to buy or a true lease is the cheaper form of financing.

The cost of a true lease depends on the size of the transaction and whether the lease is tax-oriented or nontax-oriented. The equipment leasing market can be classified into the following three market sectors: (1) a small-ticket retail market with transactions in the \$5,000 to \$100,000 range, (2) a middle market with large-ticket items covering transactions between \$100,000 and \$5 million, and (3) a special-products market involving equipment cost in excess of \$5 million.

Tax-oriented leases generally fall into the second and third markets. Most of the leveraged lease transactions are found in the third market and the upper range of the second market. The effective interest cost implied by these lease arrangements is considerably below prevailing interest rates that the same lessee would pay on borrowed funds. Even so, the potential lessee must weigh the lost economic benefits from owning the equipment against the economic benefits to be obtained from leasing.

Nontax-oriented leases fall primarily into the small-ticket retail market and the lower range of the second market. There is no real cost savings associated with these leases compared to traditional borrowing arrangements. In most cases, however, cost is not the dominant motive of the firm that employs this method of financing.

From a tax perspective, leasing has advantages that lead to a reduction in cost for a company that is in a tax-loss-carryforward position and is consequently unable to claim tax benefits associated with equipment ownership currently or for several years in the future.

Conservation of Working Capital

The most frequent advantage of leasing cited by leasing company representatives and lessees is that it conserves working capital. The reasoning is as follows: When a firm borrows money to purchase equipment, the lending institution rarely provides an amount equal to the entire price of the equipment to be financed. Instead, the lender requires the borrowing firm to take an equity position in the equipment by making a down payment. The amount of the down payment will depend on such factors as the type of equipment, the creditworthiness of the borrower, and prevailing economic conditions. Leasing, in contrast, typically provides 100% financing since it does not require the firm to make a down payment. Moreover, costs in-

curred to acquire the equipment, such as delivery and installation charges, are not usually covered by a loan agreement. They may, however, be structured into a lease agreement.

The validity of this argument for financially sound firms during normal economic conditions is questionable. Such firms can simply obtain a loan for 100% of the equipment or borrow the down payment from another source that provides unsecured credit. However, there is doubt that the funds needed by a small firm for a down payment can be borrowed, particularly during tight money periods. Also, some leases do, in fact, require a down payment in the form of advance lease payments or security deposits at the beginning of the lease term.

Preservation of Credit Capacity by Avoiding Capitalization

Current financial reporting standards for leases require a leasing obligation classified as a capital lease (discussed later) be capitalized as a liability and the equipment recorded as an asset on the balance sheet. According to Financial Accounting Standards Board (FASB) Statement No. 13, the principle for classifying a lease as a capital lease for financial reporting purposes is as follows:

A lease that transfers substantially all of the benefits and risks incident to ownership of property should be accounted for as the acquisition of an asset and the incurrence of an obligation by the lessee.

FASB Statement No. 13 specifies four criteria for classifying a lease as a capital lease. We will discuss these four criteria later in this chapter. Leases not classified as capital leases are considered operating leases. Unlike a capital lease, an operating lease is not capitalized. Instead, certain information regarding such leases must be disclosed in a footnote to the financial statement.

Many CFOs are of the opinion that avoiding capitalization of leases will enhance the financial image of their corporations. By allowing a company to avoid capitalization, an operating lease preserves credit capacity. An operating lease—and particularly a leveraged lease, discussed in the next chapter—enables a lessee to utilize institutional (lessor) equity as a source of funding somewhat like subordinated debt. Because there is generally ample room for designing lease arrangements so as to avoid having a lease classified as a capital lease, CFOs generally prefer that lease agreements be structured as operating leases.

As a practical matter, most long-term true leases (payout-type leases for the lessors) are structured to qualify as operating leases for financial accounting purposes for the lessees at the request of the lessees. Further, the

reality is that credit rating services evaluate a company's balance sheet by including the assets and liabilities of operating leases. Hence, structuring a lease as an operating lease does not, in practicality, remove it from consideration as a liability.

Risk of Obsolescence and Disposal of Equipment

When a firm owns equipment, it faces the possibility that at some future time the equipment may not be as efficient as more recently manufactured equipment. The owner may then elect to sell the original equipment and purchase the newer, more technologically efficient version. The sale of the equipment, however, may produce only a small fraction of its book value. By leasing, it is argued, the firm may avoid the risk of obsolescence and the problems of disposal of the equipment. The validity of this argument depends on the type of lease and the provisions therein.

With a *cancelable* operating lease, the lessee can avoid the risk of obsolescence by terminating the contract. However, the avoidance of risk is not without a cost since the lease payments under such lease arrangements reflect the risk of obsolescence perceived by the lessor. At the end of the lease term, the disposal of the obsolete equipment becomes the problem of the lessor. The risk of loss in residual value that the lessee passes on to the lessor is embodied in the cost of the lease.

The risk of disposal faced by some lessors, however, may not be as great as the risk that would be encountered by the lessee. Some lessors, for example, specialize in short-term operating leases of particular types of equipment, such as computers or construction equipment, and have the expertise to release or sell equipment coming off lease with substantial remaining useful life. A manufacturer-lessor has less investment exposure since its manufacturing costs will be significantly less than the retail price. Also, it is often equipped to handle reconditioning and redesigning due to technological improvements. Moreover, the manufacturer-lessor will be more active in the resale market for the equipment and thus be in a better position to find users for equipment that may be obsolete to one firm but still satisfactory to another. IBM is the best example of a manufacturer-lessor that has combined its financing, manufacturing, and marketing talents to reduce the risk of disposal. This reduced risk of disposal, compared with that faced by the lessee, is presumably passed along to the lessee in the form of a reduced lease cost.

Nonetheless, financial institutions and other lessors are financing ever larger, more complex, and longer-lived assets, and uncertainty over the residual value of those assets is one of the biggest risks for lessors. A steel plant, for example, could have an estimated useful life of 30 years, but its actual useful life could be as short as 25 years or as long as 40 years. If the useful life

of the plant turns out to be less than the lessor has projected, the lessor could suffer a loss on a lease that appeared profitable in the original analysis. For some types of assets there is abundant data to support estimates of residual value and for other types of assets there is very little data—particularly for new, unique, complex, or infrequently traded assets. The primary factors that affect residual value are the three components of depreciation: useful life (deterioration), economic obsolescence, and technological obsolescence. Rode, Fishbeck, and Dean suggest that lessors use the best information available to simulate the behavior of these three factors as well as the correlation among the three factors, based on probabilistic ranges of outcomes, to produce distributions of useful life curves, estimated values, and confidence intervals.⁴ Because conditions inevitably change over time, lessors should update their modeling frequently during the life of the equipment.

Restrictions on Management

When a lender provides funds to a firm for an extended period of time, provisions to protect the lender are included in the loan agreement. The purpose of protective provisions, or protective covenants, is to ensure that the borrower remains creditworthy during the period over which the funds are borrowed. Protective provisions impose restrictions on the borrower. Failure to satisfy such a protective covenant usually creates an event of default that, if not cured upon notice, gives the lenders certain additional rights and remedies under the loan agreement, including the right to perfect a security agreement or to demand the immediate repayment of the principal. In practice, the remedy and ability to cure vary with the seriousness of the event of default.

An advantage of leasing is that a lease agreement typically does not impose financial covenants and restrictions on management as does a loan agreement used to finance the purchase of equipment. The historical reason for this in true leases is that the Internal Revenue Service discouraged true leases from having attributes of loan agreements. Leases, however, may contain restrictions as to location of the property and additional investments by the lessee in the leased equipment in order to ensure compliance with tax laws.

Impact on Cash Flow and Book Earnings

In a properly structured true lease arrangement, the lower lease payment from leasing rather than borrowing can provide a lessee with a superior cash flow. Whether the cash flow on an after-tax basis after taking the residual

⁴ David C. Rode, Paul S. Fishbeck, and Steve R. Dean, “Residual Risk and the Valuation of Leases under Uncertainty and Limited Information,” *Journal of Structured and Project Finance* 7 (Winter 2002), pp. 37–49.

value of the equipment into account is superior on a present value basis must be ascertained.

Leasing versus buying has a different effect on book earnings. Lease payments under a true lease will usually have less impact on book earnings during the early years of the lease than will depreciation and interest payments associated with the purchase of the same equipment.

TYPES OF LESSORS

Corporate lessors may be generally categorized as commercial banks or their subsidiaries, independent leasing companies, captive leasing subsidiary companies of nonfinance companies, finance companies or their subsidiaries, investment banking firms, and subsidiaries of life or casualty insurance companies.

Many banks and bank holding companies or their subsidiaries participate indirectly in leasing through working relationships with independent and captive leasing companies. Independent leasing companies engage in equipment leasing in the same way as banks. After purchasing and taking title to the equipment requested by the lessee, most such companies lease the equipment to lessees as full-payout-type leases. However, some independent leasing companies may specialize in short-term operating leases. Specialized leasing companies provide leasing and servicing of specific equipment in a particular industry. For example, many independent leasing companies concentrate on data processing equipment.

Captive leasing or finance companies are generally subsidiaries of equipment manufacturers, and their primary purpose is to secure financing for the customers of the parent company. Captives may also be involved in the lease financing of equipment other than that manufactured by their parent company.

In recent years, many nonfinance industrial and service companies without a need to finance their own products have established captive leasing companies to engage in tax-oriented leasing of equipment. These companies have become important participants in the market.

LEASE BROKERS AND FINANCIAL ADVISERS

The growth of the leasing industry has produced a demand for intermediaries to assist lessors in servicing lessees. Lease brokers and financial advisers serve as architects or packagers of lease transactions by bringing together lessors, lessees, and, in the case of a leveraged lease, third-party lenders.

Leasing subsidiaries of banks and bank holding companies, investment bankers, commercial banks, and small independent leasing companies have all played an important role as lease brokers and financial advisers.

Lease brokers and financial advisers can perform a useful service for both lessees and lessors in arranging equipment leases. They can be especially helpful to a lessee by obtaining attractive pricing from a legitimate investor and advising the lessee in structuring and negotiating the transaction. While lease brokers and financial advisers typically represent lessees, they also can be helpful to a lessor in finding solutions to negotiating issues.

For its services as an intermediary, the lease broker or financial adviser receives a brokerage commission. The amount of the remuneration can vary widely, depending on the complexity of the deal and the attractiveness of the deal to the lessor in the prevailing economic environment. The standard fee usually ranges from 1/2% to 4% of the cost of the equipment, depending on the services provided by the broker and the size and difficulty of the transaction. In some brokered transactions, the lease broker or financial adviser also may receive at least a portion of its compensation in the form of a share participation in the residual value of the leased equipment. And, in still other situations, the broker or financial adviser will work for a flat fee.

LEASE PROGRAMS

Lessors can structure lease transactions to suit the needs of most companies. Examples of various lease programs available are described below.

A *standard lease* provides 100% long-term financing with level payments over the term of the lease. Standard documentation facilitates quick handling and closing of the lease transaction. Installation costs, delivery charges, transportation expense, and taxes applicable to the purchase of the equipment may be included as part of the lease financing package.

A *custom lease* contains special provisions designed to meet particular needs of a lessee. It may, for example, schedule lease payments to fit cash flow. Such a lease can be particularly helpful to a seasonal business.

A *master lease* works like a line of credit. It is an agreement that allows the lessee to acquire, during a fixed period of time, equipment as needed without having to renegotiate a new lease contract for each item. With this arrangement, the lessee and lessor agree to the fixed terms and conditions that will apply for various classifications of equipment for a specified period, usually six months to one year. At any time within that period, the lessee can add equipment to the lease up to an agreed maximum, knowing in advance the rate to be paid and the leasing conditions.

Designed as a sales tool for equipment manufacturers or distributors, a *vendor lease* program permits suppliers to offer financing in the form of true or conditional sale leases. Vendor leases may be structured as tax-oriented or nontax-oriented leases. They may be either short-term operating leases or full-payout leases. Vendor lease programs can be offered directly by manufacturers and distributors or in conjunction with a third-party leasing company.

An *offshore lease* is an agreement to lease equipment to be used outside the United States. Offshore lease programs offer leases calling for payments to U.S. lessors in U.S. dollars or local currencies for equipment used abroad. Both true leases and conditional sale leases can be arranged for firms requiring equipment in overseas operations. However, the tax benefits to U.S. lessors are insignificant since little depreciation is available on equipment located outside of the United States.

Sale-and-leaseback transactions can be used by a company to convert owned property and equipment into cash. The equipment is purchased by the lessor and then leased back to the seller.

Under a *facility lease*, an entire facility—a plant and its equipment—can be leased. Under this arrangement, a lessor may provide or arrange construction financing for a facility. Interest costs during construction can often be capitalized into the lease. The lease commences when the completed facility has been accepted by the lessee.

FINANCIAL REPORTING OF LEASE TRANSACTIONS BY LESSEES

Financial reporting considerations are important for most lessees and potential lessees. At one time, lessees needed only to disclose information regarding lease commitments in footnotes to their financial statements. Hence, leasing was often referred to as “off-balance-sheet financing.” With the issuance of FASB Statement No. 13 (FAS 13), the accounting treatment of lease commitments changed. FAS 13 required that certain leases be recorded on the lessee’s balance sheet as a liability and the leased property reported as an asset. This procedure is called “capitalizing a lease” or “lease capitalization.” For leases that do not meet the test specified by FAS 13, the lessee need only disclose certain information regarding lease commitments in a footnote.

Classification of Leases

According to FAS 13 (paragraph 60), a lease is classified as either an operating lease or a capital lease. The principle for classifying a lease as either operating or capital for reporting purposes is as follows:

[A] lease that transfers substantially all of the benefits and risks incident to the ownership of property should be accounted for as the acquisition of an asset and the incurrence of an obligation by the lessee. . . . All other leases should be accounted for as operating leases.

But how should the accountant interpret when substantially all of the benefits and risks of ownership are transferred? FAS 13 specifies that if one or more of the following four criteria are met for a noncancelable lease at the date of the lease agreement, the lease is to be accounted for as a capital lease:

1. The lease transfers ownership of the property to the lessee by the end of the lease term.
2. The lease contains a bargain purchase option.
3. The lease term is equal to 75% or more of the estimated economic life of the leased property.
4. The present value of the minimum lease payments (excluding executory costs)⁵ equals or exceeds 90% of the fair value of the leased property.

A lease that does not satisfy at least one of the above four criteria is classified as an operating lease.

For reasons to be discussed below, lessees prefer a lease to be classified as an operating lease. While it may appear that FAS 13 limits management's ability to structure how a lease will be treated for financial reporting purposes, this is not true in practice. There are several ways in which a lessee can structure a lease to meet its objectives, as will be discussed later.

Accounting for Operating Leases

Because an operating lease does not represent the transfer of substantially all of the benefits and risks of ownership, the leased property is not capitalized, nor is the lease obligation shown as a liability on the balance sheet. Instead, the lease payments are charged to expenses over the lease term as they become payable.

Although neither the leased asset nor the obligation appears in the balance sheet, the lessee must disclose the following information in footnotes to its financial statements: (1) a general description of the leasing arrangement, which would include restrictions imposed by the lease arrangement, the existence of renewal or purchase options, and escalation clauses; (2) the lease expense for each year in which an income statement is presented; and (3) future minimum lease payments required in the aggregate and separately for each of the next five years.

⁵ Executory costs include insurance, maintenance, and property taxes.

Accounting for Capital Leases

A capital lease is treated for accounting purposes as if the leased asset were purchased and financed over time. The question then arises as to how the value of the leased asset and the corresponding liability should be recorded on the lessee's balance sheet at the inception of the lease. FAS 13 requires that these amounts be recorded at the inception of the lease as the lower of (1) the present value of the minimum lease payments during the lease term or (2) the fair market value of the leased asset.⁶

Once the asset and liability at the inception of the lease have been determined, the depreciation charge and the interest expense associated with the liability must be determined. Although the amounts of the asset and liability are the same at the inception of the lease, the subsequent depreciation and interest expense are computed independently.

In addition, the following footnote disclosures for capital leases are required in the lessee's financial statement:

- The gross amount of assets recorded under capital leases presented by major classes according to nature or function. The lessee can combine this information for owned assets, which the company must also disclose.
- Future minimum lease payments in the aggregate and for each of the five succeeding years (deducting executory costs) and the amount of imputed interest in reducing the minimum lease payments to present value.
- Total contingent lease payments actually incurred for each period for which an income statement is presented.
- A general description of the leasing arrangement, which would include restrictions imposed by the lease arrangement, the existence of renewal or purchase options, and escalation clauses.

The impact of the accounting treatment of leases on reported income is usually minimal. The primary concern of management is therefore not with the impact on reported income, but with the effect on the firm's debt-to-equity ratio. This ratio is commonly employed by creditors and investors to determine whether a company is overburdened with debt. With a capital lease, the debt-to-equity ratio will be greater than if the lease is treated as

⁶ The minimum lease payments are defined as the sum of (1) the minimum lease payments required during the lease term and (2) the amount of any bargain purchase option. In the absence of a bargain purchase option, the amount of any guarantee of the residual value and the amount specified for failure to extend or renew the lease are used in lieu of (2). Excluded from the minimum lease payments are executory costs where these are required to be paid by the lessee to the lessor.

an operating lease because of the lease obligation reported in the balance sheet. However, it is naive to assume that market participants are untutored about the impact of noncapitalized leases on the debt-equity ratio. Certainly rating agencies take into account leasing arrangements in assigning a credit rating.

LEVERAGED LEASE FUNDAMENTALS

The leveraged form of a true lease of equipment is the ultimate form of lease financing. It allows a company, as lessee, to harness the lessor's capital, leveraged by institutional debt, as a source of funding somewhat like subordinated debt. The most attractive feature of a leveraged lease, from the standpoint of a lessee unable to use tax benefits of Modified Accelerated Cost Recovery System (MACRS), is its low cost as compared to that of alternative methods of financing. Leveraged leasing also satisfies a need for lease financing of especially large capital equipment projects with economic lives of up to 25 or more years, although leveraged leases are also used where the life of the equipment is considerably shorter. The leveraged lease can be a most advantageous financing device when used for the right kinds of projects and structured correctly.

Single-investor nonleveraged leases of equipment are simple two-party transactions involving a lessee and a lessor. In single-investor leases (sometimes called *nonleveraged leases* or *direct leases*), the lessor provides all of the funds necessary to purchase the leased asset from its own resources. While the lessor may borrow some or all of these funds, it does so on a full-recourse basis to its lenders, and it is at risk for all of the capital employed.⁷

A leveraged lease of equipment is conceptually similar to a single-investor lease. The lessee selects the equipment and negotiates the lease in much the same manner. Also, the terms for rentals, options, and responsibility for taxes, insurance, and maintenance are similar. However, a leveraged lease is appreciably more complex in size, documentation, legal involvement, and, most importantly, the number of parties involved and the unique advantages that each party gains.

Leveraged leases of equipment are generally offered only by corporations and financial institutions acting as lessors. This is because in a leveraged lease the tax benefits available to individual lessors are much more limited than those available to a corporation. Below we discuss leveraged leases offered by corporations and financial institutions.

⁷ The single-investor lessor may securitize all or part of the lease receivables at a later date.

The lessor in a leveraged lease of equipment becomes the owner of the leased equipment by providing only a percentage (20% to 30%) of the capital necessary to purchase the equipment.⁸ The remainder of the capital (70% to 80%) is borrowed from institutional investors on a nonrecourse basis to the lessor. This loan is secured by a first lien on the leased equipment, an assignment of the lease, and an assignment of the lease rental payments. The cost of the nonrecourse borrowing is a function of the credit standing of the lessee.⁹ The lease rate varies with the debt rate and with the risk of the transaction.

A leveraged lease is always a true lease. The lessor in a leveraged lease can claim all of the tax benefits incidental to ownership of the leased asset even though the lessor provides only 20% to 30% of the capital needed to purchase the equipment. This ability to claim the MACRS tax benefits attributable to the entire cost of the leased equipment and the right to 100% of the residual value provided by the lease, while providing and being at risk for only a portion of the cost of the leased equipment, is the "leverage" in a leveraged lease. Such leverage enables the lessor in a leveraged lease to offer the lessee much lower lease rates than the lessor could provide under a direct lease.

The legal expenses and closing costs associated with leveraged leases are larger than those for single-investor nonleveraged leases and usually confine the use of leveraged leases to financing relatively large capital equipment acquisitions. However, leveraged leases are also used for smaller lease transactions that are repetitive in nature and use standardized documentation so as to hold down legal and closing costs.

Several parties may be involved in a leveraged lease. Whereas direct or single-investor nonleveraged leases are basically two-party transactions with a lessee and a lessor, leveraged leases by their nature involve a minimum of three parties with diverse interests: a lessee, a lessor, and a nonrecourse lender. Indeed, leveraged leases are sometimes called three-party transactions.

Several owners and lenders may be involved in a large leveraged lease. In such a case, an owner trustee is generally named to hold title to the equipment and represent the owners or equity participants, and an indenture trustee is usually named to hold the security interest or mortgage on the property for the benefit of the lenders or loan participants. Sometimes a single trustee may be appointed to perform both of these functions.

⁸ The exact amount is a function of the economic result the lessor seeks to achieve.

⁹ If the credit of the lessee is insufficient to support the transaction, a guarantor of the lessee obligations under the lease including payment of rents may be necessary. This guarantor may, for example, be the parent or sister company of the lessee, an interested third party, or a government agency. Leveraged debt cannot usually be directly guaranteed under the tax requirements of the IRS.

Below we will review the rights, obligations, functions, and characteristics of the various parties that may be involved with a leveraged lease. We also review the structure, the cash flows, and the debt arrangements possible.¹⁰

Parties to a Leveraged Lease

The parties to a leveraged lease include:

- Lessee
- Equity participants
- Loan participants or lenders
- Owner trustee
- Indenture trustee
- Manufacturer or contractor
- Packager
- Guarantor

Lessee

The lessee selects the equipment to be leased, negotiates the price and warranties, and hires the use of the equipment by entering into a lease agreement. The lessee accepts, uses, operates, and receives all revenue from the equipment. The lessee makes rental payments. The credit standing of the lessee supports the rent obligation, the credit exposure of the lenders of leveraged debt, and the credit exposure of the equity participants.

Equity Participants

The equity participants provide the equity contributions (20% to 30% of the purchase price) needed to purchase the leased equipment. They receive the rental payments remaining after the payment of debt service and any trustee fees. They claim the tax benefits incidental to the ownership of the leased equipment, consisting of MACRS tax depreciation deductions and deductions for interest used to fund their investment. They are entitled to receive the residual value of the equipment at the end of the lease subject to limitations provided by the lease agreement. The equity participants are sometimes referred to as the lessors. Actually, in most cases they are the beneficial owners by way of an owner trust that is the lessor. Equity partici-

¹⁰ Tax requirements for leveraged leases are discussed in Chapter 5 of Peter K. Nevitt and Frank J. Fabozzi, *Equipment Leasing*, 4th ed. (Hoboken, NJ: John Wiley & Sons, 2000).

pants are also sometimes referred to as equity investors, owner participants, or trustees.

Loan Participants or Lenders

The loan participants or lenders are typically banks, finance companies, insurance companies, trusts, pension funds, and foundations. The funds provided by the loan participants, together with the equity contributions, make up the full purchase price of the asset to be leased. The loan participants provide 70% to 80% of the purchase price on a nonrecourse basis to the equity participants. As noted earlier, these loans are secured by a first lien on the leased equipment, an assignment of the lease, an assignment of rents under the lease, and an assignment of any ancillary agreements such as easements and supply contracts. Principal and interest payments that are due the loan participants (or lenders) from the indenture trustee are paid by the lessee to the indenture trustee, which then pays the loan participants.

Owner Trustee

The owner trustee represents the equity participants, acts as the lessor, and executes the lease and all of the basic documents that the lessor would normally sign in a lease. The owner trustee records and holds title to the leased asset for the benefit of the equity participants, subject to the mortgage or security agreement to the indenture trustee. The owner trustee issues trust certificates to the equity holders evidencing their beneficial interest as owners of the assets of the trust, issues bonds or notes to loan participants evidencing the leveraged debt, grants to the indenture trustee the security interests that secure repayment of the bonds (that is, the lease, the lease rentals, and a first mortgage on the leased asset), receives distributions from the indenture trustee, distributes earnings to the equity participants, and receives and distributes any information or notices regarding the transaction that are required to be provided to the parties. The owner trustee has little discretionary power beyond that specifically granted in the trust agreement and has no affirmative duties.

The owner participants indemnify the owner trustee against costs and liabilities arising out of the transaction, except for willful misconduct or negligence. It can be argued that an owner trustee is unnecessary. Where a leveraged lease has a single equity investor, the parties may conclude that an owner trustee is not needed and that the equity investor may act as the lessor. However, the cost of an owner trustee for a leveraged lease is usually modest compared with the benefits unless the transaction is extremely simple and straightforward.

Indenture Trustee

The indenture trustee (sometimes called the security trustee) is appointed by and represents the lenders or loan participants. The owner trustee and the indenture trustee enter into a trust indenture whereby the owner trustee assigns to the indenture trustee, for the benefit of the loan participants and as security for the leveraged debt and any other obligations, all of the owner trustee's interest as lessor in:

- The equipment to be leased and the lessor's rights under manufacturer's or contractor's warranties related to the equipment.
- The lease agreement.
- The lessor's right to receive rents (including all payments) owed by the lessee (subject to such exceptions as agreed between the lessor and lessee).
- The lessor's rights to receive any payments under any guarantee agreements (subject to the same exceptions as the payments due the lessor).
- The lessor's rights under any ancillary facility support agreements such as easements, service contracts, supply contracts, and sales contracts.

The indenture agreement sets forth the form of the notes or loan agreements, the events of default, and the instructions and priorities for distributions of funds to the loan participants and other parties.

The indenture trustee receives funds from the loan participants (lenders) and the equity participants when the transaction is about to close, pays the manufacturer or contractor the purchase price of the equipment to be leased, and records and holds the senior security interest in the leased equipment, the lease, any ancillary facility support contracts, and the rents for the benefit of the loan participants. The indenture trustee collects rents and other sums due under the lease from the lessee. Upon the receipt of rental payments, the indenture trustee pays debt payments of principal and interest due on the leveraged debt to the loan participants and distributes revenues not needed for debt service to the owner trustee. In the event of default, the indenture trustee can foreclose on the leased equipment and take other appropriate actions to protect the security interests of the loan participants.¹¹

¹¹ A single trustee may assume the duties of both an owner trustee and an indenture trustee in a leveraged lease. Where a single trustee is used, the trustee is referred to as the owner trustee. Those who favor using a single trustee in a leveraged lease transaction argue that such an arrangement is simpler and reduces the costs of the transaction. Although the use of a single trustee in a leveraged lease has become an increasingly common arrangement, serious conflicts of interest may arise between the equity participants and the loan participants in the event of a default by the lessee. Such potential conflicts make the use of a single trustee unattractive if there is any question regarding the lessee's credit.

Manufacturer or Contractor

The manufacturer or contractor manufactures or constructs the equipment to be leased. The manufacturer or contractor (or supplier) receives the purchase price upon acceptance of the equipment by the lessee and delivers the equipment to the lessee at the beginning of the lease. The warranties of the manufacturer, contractor, or supplier as to the quality, capabilities, and efficiencies of the leased equipment are important to the lessee, the equity participants, and the loan participants.

Packager or Broker

The packager or broker is the leasing company arranging the transaction. In many instances, the packager is purely a broker and not an investor. From the standpoint of the lessee, it may be desirable that the packager also be an equity participant. The packager may, in fact, be the sole equity participant.

Guarantor

A guarantor of the lessee's credit may be present in some leveraged lease transactions. Although a member of the lessee group may not guarantee the leveraged debt under Internal Revenue rules, a member of the lessee group may guarantee the lessee's obligation to pay rent. A party unrelated to the lessee may guarantee either rents or debt. Such a guarantor might be a third party such as a bank under a letter-of-credit agreement, an insurer of residual value, or a government guarantor.¹²

Structure of a Leveraged Lease

A leveraged lease transaction is usually structured as follows where a broker or a third-party leasing company arranges the transaction.

The leasing company arranging the lease, "the packager," enters into a commitment letter with the prospective lessee (obtains a mandate) that outlines the terms for the lease of the equipment, including the timing and amount of rental payments. Since the exact rental payment cannot be determined until the debt has been sold and the equipment delivered, rents are agreed tentatively based on certain variables, including assumed debt rates and the delivery dates of the equipment to be leased.

¹² Where rents are guaranteed by a third party, a controversy may arise under Revenue Procedure 75-21 that relates to whether the lessor is at risk for an amount equal to 20% of the cost of the equipment. It can be strongly argued that such a guarantee is merely the equivalent of a second credit exposure and does not alter the fact that the lessor is "at risk."

After the commitment letter has been signed, the packager prepares a summary of terms for the proposed lease and contacts potential equity participants to arrange for firm commitments to invest equity in the proposed lease to the extent that the packager does not intend to provide the total amount of the required equity funds from its own resources. Contacts with potential equity sources may be fairly informal or may be accomplished through a bidding process. Typical equity participants include banks, independent finance companies, captive finance companies, and corporate investors that have tax liability to shelter, have funds to invest, and understand the economics of tax-oriented leasing. The packager may also arrange the debt either directly or in conjunction with the capital markets group of a bank or an investment banker selected by the lessee or the lessor. If the equipment is not to be delivered and the lease is not to commence for a considerable period of time, the debt arrangements may be deferred until close to the date of delivery.

The packager may agree at the outset to *bid firm* or underwrite the transaction on the mandated terms and may then *syndicate* its bid to potential equity participants. However, the lessee may prefer to use a bidding procedure without an underwritten price on the theory that more favorable terms can be arranged using this approach.

In some instances, the lessee may prefer to prepare its own bid request and solicit bids directly from potential lessors without using a packager or broker to underwrite or arrange the transaction. This might be the case, for example, where the lessee has considerable experience in leveraged leasing and has already arranged leases of similar equipment, such as computers or computer systems.

If an owner trustee is to be used, a bank or trust company mutually agreeable to the equity participants and the lessee is selected to act as owner trustee. If an indenture trustee is to be used, another bank or trust company acceptable to the loan participants is selected to act as indenture trustee. As discussed previously, a single trustee may act as both owner trustee and indenture trustee.

Figure 17.1 illustrates the parties, cash flows, and agreements among the parties in a simple leveraged lease.

If the leveraged lease is arranged by sponsors of a project who want to be the equity participants, the structure and procedures are essentially the same as those for a leveraged lease by a third-party equity participant. In such circumstances, the sponsors are the equity investors. If some of the sponsors can use tax benefits and some cannot, the equity participants may include a combination of sponsors and one or more third-party leasing companies. This arrangement is more complex, but the structure and procedures are essentially the same as those for a leveraged lease by a third-party equity participant.

FIGURE 17.1 Leveraged Lease

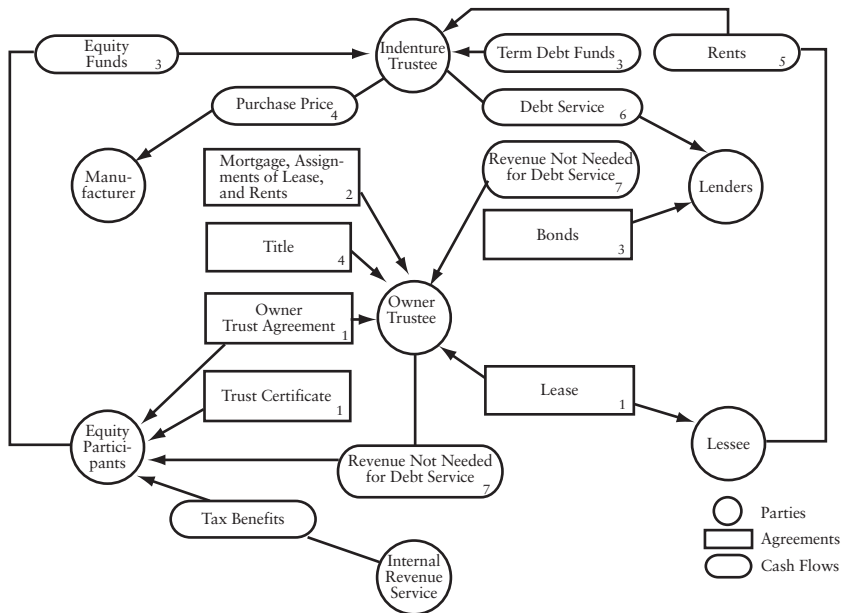

Summary:

1. An owner trust is established by the equity participants, trust certificates are issued, and a lease agreement is signed by the owner trustee as lessor and the lessee.
2. A security agreement is signed by the owner trustee and the indenture trustee, a mortgage is granted on the leased asset, and the lease and rentals are assigned as security to the indenture trustee.
3. Notes or bonds are issued by the owner trustee to the lenders, term debt funds are paid by the lenders (loan participants) to the indenture trustee, and equity funds are paid by the equity participants to the indenture trustee.
4. The purchase price is paid, and title is assigned to the owner trustee, subject to the mortgage.
5. The lease commences; rents are paid by the lessee to the indenture trustee.
6. Debt service is paid by the indenture trustee to the lenders (loan participants).
7. Revenue not required for debt service or trustees' fees is paid to the owner trustee and in turn to the equity participants.

Source: Exhibit 1 in Chapter 16 of Peter K. Nevitt and Frank J. Fabozzi, *Equipment Leasing*, 4th ed. (Hoboken, NJ: John Wiley & Sons, 2000), p. 328.

Closing the Transaction

Participation Agreement

The key document in a leveraged lease transaction is the *participation agreement* (sometimes called the *financing agreement*). This document is, in effect, a script for closing the transaction.

When the parties to a leveraged lease transaction are identified, all of them except the indenture trustee enter into a participation agreement that spells out in detail the various undertakings, obligations, mechanics, timing, conditions precedent, and responsibilities of the parties with respect to providing funds and purchasing, leasing, and securing or mortgaging the equipment to be leased. More specifically, the equity participants agree to provide their investment or equity contribution; the loan participants agree to make their loans; the owner trustee agrees to purchase and lease the equipment; and the lessee agrees to lease the equipment. The substance of the required opinions of counsel is described in the participation agreement. The representations of the parties are detailed. Tax indemnities and other general indemnities are often set forth in the participation agreement rather than the lease agreement. The exact form of agreements to be signed, the opinions to be given, and the representations to be made by the parties are usually attached as exhibits to the participation agreement.

Other Key Documents

The key documents in a leveraged lease transaction in addition to the participation agreement are: the lease agreement, the owner trust agreement, and the indenture trust agreement.

The lease agreement is between the lessee and owner trustee. The lease is for a term of years and may contain renewal options and fair-market-value purchase options. Rents and all payments due under the lease are net to the lessor, and the lessee waives defenses and offsets to rents under a “hell-or-high-water clause.”

The owner trust agreement creates the owner trust and sets forth the relationships between the owner trustee and the equity participants that it represents. The owner trust agreement spells out the duties of the trustee, the documents the trustee is to execute, and the distribution to be made of funds it receives from equity participants, lenders, and the lessee. The owner trustee has little or no authority to take discretionary or independent action.

The owner trust grants a lien or security interest on the leased equipment and assigns the lease agreement, any ancillary facility support agreements, and right to receive rents under the lease to the indenture trustee

(which may also be the owner trustee). It spells out the obligations of the indenture trustee to the lenders.

Indemnities by the Lessee

Lessee indemnities fall into three general categories:

1. A general indemnity that protects all of the other parties to the transaction from any claims of third parties arising from the lease or the use of the leased equipment.
2. A general tax indemnity that protects all of the other parties to the transaction from all federal, state, or local taxes arising out of or in connection with the transaction except for certain income tax or income-related taxes.
3. Special tax indemnities by the lessee that protect the owner participants from the loss of expected income tax benefits as a result of the acts and omissions of the lessee and certain other events.

The coverage of the special tax indemnities beyond the acts and omissions of the lessee is a matter of significant negotiation between the lessee and lessor.

Cash Flows During the Lease

The equity participants receive cash flow from three sources: rents after the payment of debt service and trustee fees, tax benefits, and proceeds from the sale of the equipment at the conclusion of the lease.

The lessee pays periodic rents to the indenture trustee, which uses such funds to pay currently due principal and interest payments to the loan participants and to pay trustee fees for its services. The balance of the rental payments is paid to the owner trustee. After the payment of any trustee fees due the owner trustee and any administrative or other expenses, the owner trustee pays the remainder of the rental payments to the equity participants.

The equity participants also realize cash flow from tax benefits as quickly as they can claim such benefits on their quarterly tax estimates and tax returns.

The leveraged debt is usually amortized over a period of time identical to the lease term, with payments of principal and interest due on or shortly after the due date of the rental payments. These payments may be monthly, quarterly, semiannual, or annual. Where “optimized debt” structures are used for competitive reasons, the rental payments approximately equal the debt service payments plus deferred income tax. This has the effect of reducing the

leveraged debt payments in the later years of the lease. Rental payments are usually level but may vary upward or downward (sawtooth rents) to achieve a maximum yield for the lessor. Also, debt payments may be concluded entirely before the lease term ends in order to generate additional cash for the lessor.

When the lease terminates, the equipment is returned to the owner trustee, who sells or releases the property at the direction of the owner participants.

The lease agreement usually requires the lessee to furnish the owner trustee and the indenture trustee with financial statements, evidence of insurance, and other similar information. The trustees distribute this information to all parties to the transaction.

Debt for Leveraged Leases

Debt for leveraged leases is usually at a fixed rate of interest although it also may be at a floating rate of interest. Such debt is available from a variety of sources. The lead equity source or packager may arrange the debt. Sometimes the lessee may prefer to have the debt arranged by its commercial bank, the capital markets group of its commercial bank, or its investment bank. Most leveraged lease debt is raised in the private placement market at little or no premium over what the lessee would expect to pay directly for such debt. The sources include:

- Insurance companies
- Pension plans
- Profit-sharing plans
- Commercial banks
- Finance companies
- Savings banks
- Domestic leasing companies
- Foreign banks
- Foreign leasing companies
- Foreign investors
- Institutional investors

FEDERAL INCOME TAX REQUIREMENTS FOR TRUE LEASE TRANSACTIONS

Remember that the Internal Revenue Service is concerned with the classification of a lease because tax benefits are affected. The Internal Revenue Code (IRC) has requirements for a lease to be treated as a true lease. These rules are independent of the rules for classifying a lease as set forth in FAS

13. The IRC distinguishes between nontax-oriented leases (i.e., conditional sale leases) and tax-oriented true leases.¹³ The major characteristic differentiating nontax-oriented and tax-oriented true leases is the type of purchase options available to the lessee. True leases have fair-market-value types of purchase options. Conditional sale leases have nominal fixed-price purchase options or automatically pass the title to the lessee at the end of the lease.

Revenue Ruling 55-540 (1955-2 *Cum. Bull.* 39) states:

Whether an agreement, which in form is a lease, is in substance a conditional sales contract depends upon the intent of the parties as evidenced by the provisions of the agreement, read in light of the facts and circumstances existing at the time the agreement was executed. In ascertaining such intent no single test, nor special combination of tests, is absolutely determinative. No general rule, applicable in all cases, can be laid down. Each case must be decided in the light of its particular facts.

A purchase option based on fair market value rather than a nominal purchase option is a strong indication of intent to create a lease rather than a conditional sale. The test is whether the interest of the lessor in the leased property is a proprietary interest with attributes of ownership rather than a mere creditor's security interest in the leased property.

A lease *generally* qualifies as a true lease for tax purposes if all of the following criteria are met:

- At the start of the lease, the fair market value of the leased property projected for the end of the lease term equals or exceeds 20% of the original cost of the leased property (excluding frontend fees and any cost to the lessor for removal).
- At the start of the lease, the leased property is projected to retain at the end of the initial term a useful life that (1) exceeds 20% of the original estimated useful life of the equipment and (2) is at least one year.
- The lessee does not have a right to purchase or release the leased property at a price that is less than its then-fair-market value.
- The lessor does not have a right to cause the lessee to purchase the leased property at a fixed price.
- At all times during the lease term, the lessor has a minimum unconditional at-risk investment equal to at least 20% of the cost of the leased property.
- The lessor can show that the transaction was entered into for profit, apart from tax benefits resulting from the transaction.

¹³ These are often referred to as nontax leases and tax leases, respectively.

- The lessee does not furnish any part of the purchase price of the leased property and has not loaned or guaranteed any indebtedness created in connection with the acquisition of the leased property by the lessor.

Additional criteria and guidelines for true leases are described in various IRS Revenue Rulings and Revenue Procedures.

In the United States, a taxable owner under a true lease cannot begin to receive tax benefits until its assets are completed and in service. Therefore, true leases are generally used to finance the acquisition of existing assets rather than greenfield projects—projects at the preconstruction stage. Some lenders, principally bank lenders, are willing to take construction risk on greenfield projects, whereas other long-term lenders, such as insurance companies, generally make long-term loans on projects only after construction is complete. Some lease investors as well are reluctant to take construction completion risk. Sometimes financial institutions provide bridge leasing or other forms of bridge financing that is taken out by a longer-term true lease at the end of construction.¹⁴

In structuring a tax-oriented lease transaction, a corporation requiring the use of equipment will seek to have the lease treated as an operating lease for financial reporting purposes to avoid showing a debt obligation on the balance sheet but as a true lease for tax purposes so that the tax benefits of ownership can be transferred to the lender.

While the requirements and guidelines set forth for a lease transaction to be treated as a true lease for tax purposes are reasonably straightforward, there is sometimes room for interpretation; there are transactions intended to be true leases that the IRS might view as conditional sale leases. If this were to occur for a tax-oriented transaction, the economics of such a transaction would be changed by an adverse IRS ruling. Consequently, for complex transactions in which the parties fear they might be viewed by the IRS as not meeting the requirements and guidelines, the parties would seek an advanced ruling from the IRS as to how it would treat the transaction.

Lease agreements generally provide for an indemnity against the possible loss by the lessor of the income tax benefits the lessor expects to receive.

SYNTHETIC LEASES

One of the attractions of a true lease of equipment for lessees is the off-balance-sheet treatment of the lease obligation. One of the drawbacks of a true lease of equipment for many lessees (and particularly those able to utilize

¹⁴ David Fowkes, Nasir Kahn, and Don Armstrong, "Leasing in Project Financing," *Journal of Project Finance* 6 (Spring 2000), pp. 21–32.

tax benefits associated with equipment ownership) is the possible loss to be experienced when the true lease terminates and the equipment may have to be acquired from the lessor.

The *synthetic lease* was developed to meet this need by providing the lessee with off-balance-sheet treatment of the lease obligation while at the same time protecting the lessee's cost of acquiring the residual value of the leased equipment at the termination of the lease.¹⁵ The company using the equipment establishes a special-purpose entity (SPE) that holds title to the property and then the SPE leases the property to the company. To obtain the funds to acquire the leased property, the SPE issues notes to the lenders with the notes secured by the property and certificates issued to the equity holders. The lease rate on the property is set so that lease payments are sufficient to cover debt service payments to the note holders. A lessee with a strong credit would be able to obtain a lease rate that is less than that available in a traditional sale-and-leaseback arrangement. Tax benefits of equipment ownership are claimed by the lessee in a synthetic lease.

Historically, synthetic leases are operating leases for accounting purposes but they are structured as financing leases for tax purposes. They are off-balance-sheet leases in which the lessee remains the owner of the assets that are financed and retains the tax benefits associated with ownership while simultaneously enjoying the benefits of an operating lease. Such synthetic leases are structured using a lease agreement between the user or owner of equipment as the "lessee" and an investor as the "lessor" in a manner that satisfies the requirements for an operating lease defined in FAS 13 and related accounting rules.

After the collapse of Enron, there was an attack on all forms off-balance-sheet financing. Consider, for example, the case of the synthetic leases by Krispy Kreme, a donut maker and franchisor.¹⁶ *Forbes* first identified this company in its criticism of synthetic leasing noting that this type of financing was used for a \$35 million mixing plant and warehouse in Illinois. Later, the *New York Post* in a full-length-page article stated that management of the company was using synthetic leases to "make an entire doughnut fac-

¹⁵ The synthetic lease seems to have been first popularized in the mid-1990s by the technology companies. For example, in December 1996, Cisco Systems, Inc. entered into a synthetic lease for \$250 million to finance the expansion of its facilities at a time when traditional leases or ownership were not attractive alternatives. At the time, real estate loans were extremely difficult to obtain because of collapse of the real estate market in California. (See Ian Springsteel, "Virtual Ownership," *CFO* (September 1, 1997).) These leases were subsequently used in financing real estate investments such as research and development facilities, warehouses, office buildings, distribution centers, and hotels.

¹⁶ Nick Evans, "Enronitis, Witch-Hunts and Financial Hypochondria," *Institutional Investor* (March 1, 2002).

tory disappear.” The response was that Krispy Kreme unwound its synthetic leases at a considerable economic cost and refinanced using traditional mortgage financing in order to avoid the market misinterpreting the purpose for which it used synthetic lease financing.

As explained in Chapter 3, FASB Interpretation No. 46 (“Consolidation of Special Purpose Entities and Primary Beneficiaries”) sets forth rules for determining whether for financial accounting purposes an SPE must be consolidated. The key to consolidation is the identity of the residual beneficiary of the SPE. For most leases, the synthetic lease can be interpreted as providing the residual benefits to the lessee and hence for accounting purposes requires consolidation, eliminating the intended accounting objective of off-balance-sheet financing for many such leases. Moreover, if leases can be restructured so as to avoid consolidation as required by Financial Interpretation No. 46, synthetic leases may not be as attractive as they were in the past.

If a company wants to unwind a synthetic lease and put the leased property on its balance sheet as an asset along with a corresponding liability, the impact depends on the market value of the leased property. If the leased asset has declined in value, there will be a realized loss for financial reporting purposes. As a result of Financial Interpretation No. 46, Sempra Energy put a \$630 million synthetic lease back on its balance sheet, an action that resulted in a \$26 million reduction in income.¹⁷

Furthermore, also as explained in Chapter 3, Section 401(a) of the Sarbanes-Oxley Act requires a discussion in a separate section within the management discussion and analysis section in SEC filings on off-balance-sheet arrangements that it is reasonable to assume will have an effect on not only the firm’s financial condition but other matters material to investors.¹⁸ Synthetic leases are likely to fall into this category of off-balance-sheet transactions.

VALUING A LEASE: THE LEASE OR BORROW-TO-BUY DECISION

Now that we know what a lease is and the key role of the treatment of tax benefits and residual value in a lease transaction, we will show how to value a lease. Several economic models for valuing a lease have been proposed in the literature. The model used here requires the determination of the net present value of the direct cash flow resulting from leasing rather than

¹⁷ Tim Reason, “All in the Family,” *CFO* (September 1, 2004).

¹⁸ In addition to these disclosures, required for fiscal years ending on or after June 15, 2003, companies must also present a table of material contractual obligations for reports for fiscal years ending on or after December 15, 2003.

borrowing to purchase an asset, where the direct cash flow from leasing is discounted using an “adjusted discount rate.”¹⁹ The model is derived from “the objective of maximizing the equilibrium market value of the firm, with careful consideration of interactions between the decision to lease and the use of other financing instruments by the lessee.”²⁰

Direct Cash Flow from Leasing

When a firm elects to lease an asset rather than borrow money to purchase the same asset, this decision will have an impact on the firm’s cash flow. The cash flow consequences, which are stated relative to the purchase of the asset, can be summarized as follows:

- There will be a cash inflow equivalent to the cost of the asset.
- The lessee may or may not forgo some tax credit. For example, prior to the elimination of the investment tax credit, the lessor could pass this credit through to the lessee.
- The lessee must make periodic lease payments over the life of the lease. These payments need not be the same in each period. The lease payments are fully deductible for tax purposes if the lease is a true lease. The tax shield is equal to the lease payment times the lessee’s marginal tax rate.
- The lessee forgoes the tax shield provided by the depreciation allowance since it does not own the asset. The tax shield resulting from depreciation is the product of the lessee’s marginal tax rate times the depreciation allowance.

¹⁹ The adjusted discount rate technique presented in this chapter is fundamentally equivalent to and results in the same answer that is obtained by comparing financing provided by a loan that gives the same cash flow as the lease in every future period. This will be illustrated below.

Although the adjusted discount rate technique is fundamentally equivalent to calculating the adjusted present value of a lease, it is less accurate. The adjusted present value technique, which was described in Chapter 16, takes into consideration the present value of the side effects of accepting a project financed with a lease. (The adjusted present value technique was first developed by Stewart C. Myers, “Interactions of Corporate Financing and Investment Decisions: Implications for Capital Budgeting,” *Journal of Finance* (March 1974), pp. 1–26.) The reason for a possible discrepancy between the solutions to the lease versus borrow-to-buy decision using the adjusted discount rate technique and adjusted present value technique is that different discount rates are applied where necessary in discounting the cash flow when the latter technique is used.

²⁰ Stewart C. Myers, David A. Dill, and Alberto J. Bautista, “Valuation of Financial Lease Contracts,” *Journal of Finance* (June 1976), p. 799.

- There will be a cash outlay representing the lost after-tax proceeds from the residual value of the asset.

For example, consider the capital budgeting problem faced by the Hieber Machine Shop Company. The company is considering the acquisition of a machine that requires an initial net cash outlay of \$59,400 and will generate a future cash flow for the next five years of \$16,962, \$19,774, \$20,663, \$21,895, and \$26,825. Assuming a discount rate of 14%, representing the company's weighted average cost of capital, the net present value (NPV) for this machine was found to be \$11,540.

Let's assume that the following information was used to determine the initial net cash outlay and the cash flow for the machine:

Cost of the machine = \$66,000

Tax credit²¹ = \$6,600

Estimated pre-tax residual = \$6,000 value after disposal costs

Estimated after-tax proceeds from residual value = \$3,600

Economic life of the machine = 5 years

Depreciation is assumed to be as follows:²²

| Year | Depreciation Deductions |
|------|-------------------------|
| 1 | \$9,405 |
| 2 | 13,794 |
| 3 | 13,167 |
| 4 | 13,167 |
| 5 | 13,167 |

The same machine may be leased by the Hieber Machine Shop Company. The lease would require five annual payments of \$13,500, with the first payment due immediately. The lessor would retain the assumed tax credit. The tax shield resulting from the lease payments would be realized at the time that Hieber Machine Shop Company made those payments. No additional annual expenses will be incurred by Hieber Machine Shop Com

²¹ We use a tax credit in this illustration to show how the model can be applied should Congress decide to introduce some form of tax credit for capital investments in future tax legislation.

²² The depreciation schedule used in this illustration is for illustrative purposes only. The depreciation schedule to use at any given time is based on current tax law, which is subject to change. The depreciation in this example is based on a depreciable basis comprised of the cost of the asset, less one-half of the tax credit, or \$66,000 - \$3,300 = \$62,700. The rates of depreciation for the five years, in order, are 15%, 22%, 21%, 21%, and 21%.

pany by owning rather than leasing (that is, the lease is a net lease). The lessor will not require Hieber Machine Shop Company to guarantee a minimum residual value.

Table 17.1 presents the worksheet for the computation of the direct cash flow from leasing rather than borrowing to purchase. The marginal tax rate of Hieber Machine Shop Company is assumed to be 40%. The direct cash flow is summarized below:

| Year | | | | | |
|----------|------------|------------|------------|------------|-----------|
| 0 | 1 | 2 | 3 | 4 | 5 |
| \$51,300 | (\$11,862) | (\$13,618) | (\$13,367) | (\$13,367) | (\$8,867) |

The direct cash flow from leasing was constructed assuming that (1) the lease is a net lease and (2) the tax benefit associated with an expense is realized in the tax year the expense is incurred. These two assumptions require further discussion.

First, if the lease is a gross lease instead of a net lease, the lease payments must be reduced by the cost of maintenance, insurance, and property taxes. These costs are assumed to be the same regardless of whether the asset is leased or purchased with borrowed funds. Where have these costs been incorporated into the analysis? The cash flow from owning an asset is constructed by subtracting the additional operating expenses from the additional revenue. Maintenance, insurance, and property taxes are included in the additional operating expenses. There may be instances when the cost of maintenance differs depending on the financing alternative selected. In such cases, an adjustment to the value of the lease must be made.

Second, many firms considering leasing may be currently in a nontaxpaying position but anticipate being in a taxpaying position in the future. The derivation of the lease valuation model presented in the next section does not consider this situation. It assumes that the tax shield associated with an expense can be fully absorbed by the firm in the tax year in which the expense arises. There is a lease valuation model that, under certain conditions, will handle the situation of a firm currently in a nontaxpaying position.²³

Valuing the Direct Cash Flow from Leasing

Because the lease displaces debt, the direct cash flow from leasing should be further modified by devising a loan that in each period except the initial period engenders a net cash flow that is identical to the net cash flow for the

²³ The generalized model is explained and illustrated in Julian R. Franks and Stewart D. Hodges, "Valuation of Finance Contracts: A Note," *Journal of Finance* (May 1978), pp. 657–669.

TABLE 17.1 Worksheet for Direct Cash Flow from Leasing: Hieber Machine Shop Company^a

| | End of Year | | | | | |
|--|-------------|------------|------------|------------|------------|-----------|
| | 0 | 1 | 2 | 3 | 4 | 5 |
| Cost of machine | \$66,000 | | | | | |
| Lost tax credit | (6,600) | | | | | |
| Lease payment | (13,500) | (\$13,500) | (\$13,500) | (\$13,500) | (\$13,500) | |
| Tax shield from lease payment ^b | 5,400 | 5,400 | 5,400 | 5,400 | 5,400 | |
| Lost depreciation tax shields ^c | | (3,762) | (5,518) | (5,267) | (5,267) | (\$5,267) |
| Lost residual value | | | | | | (3,600) |
| Total | \$51,300 | (\$11,862) | (\$13,618) | (\$13,367) | (\$13,367) | (\$8,867) |

^a Parentheses denote cash outflow.

^b Lease payment multiplied by the marginal tax rate (40%).

^c Depreciation for year multiplied by the marginal tax rate (40%).

lease obligation; that is, financial risk is neutralized. Such a loan, called an *equivalent loan*, is illustrated later. Fortunately, it has been mathematically demonstrated that rather than going through the time-consuming effort to construct an equivalent loan, all the CFO need do is discount the direct cash flow from leasing by an adjusted discount rate. The adjusted discount rate can be approximated using the following formula:²⁴

$$\text{Adjusted discount rate} = (1 - \text{Marginal tax rate}) \times (\text{Cost of borrowing money})$$

The formula assumes that leasing will displace debt on a dollar-for-dollar basis.²⁵

Given the direct cash flow from leasing and the adjusted discount rate, the NPV of the lease can be computed. We shall refer to the NPV of the lease as simply the *value of the lease*. A negative value for a lease indicates that leasing will not be more economically beneficial than borrowing to purchase. A positive value means that leasing will be more economically beneficial. However, leasing will be attractive only if the NPV of the asset assuming normal financing is positive and the value of the lease is positive, or if the sum of the NPV of the asset assuming normal financing and the value of the lease is positive.

In order to evaluate the direct cash flow from leasing for the machine considered by the Hieber Machine Shop Company in our illustration, we must know the firm's cost of borrowing money. Suppose that the cost of borrowing money has been determined to be 10%. The adjusted discount rate is then found by applying the formula:

$$\text{Adjusted discount rate} = (1 - 0.40) \times (0.10) = 0.06, \text{ or } 6\%$$

The adjusted discount rate of 6% is then used to determine the value of the lease. The worksheet is shown as Table 17.2. The value of the lease is -\$448. Hence, from a purely economic point of view, the machine should be

²⁴ As noted by Brealey and Myers, "The direct cash flows are typically assumed to be safe flows that investors would discount at approximately the same rate as the interest and principal on a secured loan issued by the lessee" (Richard Brealey and Stewart Myers, *Principles of Corporate Finance* (New York: McGraw Hill, 1981), p. 629). There is justification for applying a different discount rate to the various components of the direct cash flow from leasing.

²⁵ Brealey and Myers, *Principles of Corporate Finance*, p. 634. The formula must be modified, as explained later, if the lessee believes that leasing does not displace debt on a dollar-for-dollar basis.

TABLE 17.2 Worksheet for Determining the Value of a Lease

| End of Year | Direct Cash Flow from Leasing | Present Value of \$1 at 6% | Present Value |
|-------------------------|-------------------------------|----------------------------|---------------|
| 0 | \$51,300 | 1.0000 | \$51,300 |
| 1 | (11,862) | 0.9434 | (11,191) |
| 2 | (13,618) | 0.8900 | (12,120) |
| 3 | (13,367) | 0.8396 | (11,223) |
| 4 | (13,367) | 0.7921 | (10,588) |
| 5 | (8,867) | 0.7473 | (6,626) |
| Value (or NPV) of lease | | | \$(448) |

purchased by the Hieber Machine Shop Company rather than leased. Recall that the NPV of the machine assuming normal financing is \$11,540.

Concept of an Equivalent Loan

The value of the lease considered by the Hieber Machine Shop Company was shown to be $-\$448$. Suppose the firm had the opportunity to obtain a \$51,748 five-year loan at 10% interest with the following principal repayment schedule:²⁶

| End of year | 0 | 1 | 2 | 3 | 4 | 5 |
|-------------|---|---------|----------|----------|----------|---------|
| Repayment | 0 | \$8,757 | \$11,039 | \$11,450 | \$12,137 | \$8,365 |

(Recall that the firm's marginal borrowing rate was assumed to be 10%.)

Table 17.3 shows the net cash flow for each year if the loan is used to purchase the machine. In addition to the loan, the firm must make an initial outlay of \$7,652.

The net cash flow for each year if the machine is leased is also presented in Table 17.3. Notice that the net cash flows of the two financing alternatives are equivalent, with the exception of year 0. Therefore, the loan presented above is called the *equivalent loan for the lease*.

We can now understand why borrowing to purchase is more economically attractive for Hieber Machine Shop Company. The equivalent loan produces the same net cash flow as the lease in all years after year 0. Hence, the equivalent loan has equalized the financial risk of the two financing alternatives. However, the net cash outlay in year 0 is \$7,652 compared to

²⁶ The loan payments are determined by solving for the set of repayments and interest each period that would result in the value of purchase (accompanied by a loan) being equivalent to leasing.

TABLE 17.3 Equivalent Loan for Lease versus Borrow-to-Buy Decision Faced by Hieber Machine Shop Company

| Period | 0 | 1 | 2 | 3 | 4 | 5 |
|-----------------------------------|-----------|-----------|-----------|-----------|-----------|---------|
| Leasing: Cash flows: | | | | | | |
| - Lease payments | -\$13,500 | -\$13,500 | -\$13,500 | -\$13,500 | -\$13,500 | \$0 |
| + Tax shield | 5,400 | 5,400 | 5,400 | 5,400 | 5,400 | 0 |
| Net cash flow | -\$8,100 | -\$8,100 | -\$8,100 | -\$8,100 | -\$8,100 | \$0 |
| Purchasing: Cash flows: | | | | | | |
| - Purchase cost | -\$66,000 | | | | | \$3,600 |
| + Tax credit | 6,600 | | | | | |
| + Residual value | | | | | | |
| + Depreciation tax shield | 0 | \$3,762 | \$5,518 | \$5,267 | \$5,267 | 5,267 |
| + Loan | 51,748 | | | | | |
| - Principal repayment | 0 | -8,757 | -11,039 | -11,450 | -12,137 | -8,365 |
| - Interest on loan | 0 | -5,175 | -4,299 | -3,195 | -2,050 | -836 |
| + Interest tax shield | 0 | 2,070 | 1,720 | 1,278 | 820 | 334 |
| Net cash flow | -\$7,652 | -\$8,100 | -\$8,100 | -\$8,100 | -\$8,100 | \$0 |
| Loan account: | | | | | | |
| Previous balance | \$0 | \$51,748 | \$42,991 | \$31,953 | \$20,503 | \$8,365 |
| Principal repayment (+ loan) | +51,748 | -8,757 | -11,039 | -11,450 | -12,137 | -8,365 |
| New balance | \$51,748 | \$42,991 | \$31,953 | \$20,503 | \$8,365 | \$0 |
| Value (NPV) of lease ^a | -\$448 | | | | | |

^a Difference between the net cash flows in year 0 [-8,100 - (-7,652)].

\$8,100 if the machine is leased. The difference, $-\$448$, is the value of the lease. Notice that the lease valuation model produced the same value for the lease without constructing an equivalent loan.

Comparison of Alternative Leases

The potential lessee may have the opportunity to select from several leasing arrangements offered by the same lessor or different lessors. From a purely economic perspective, the potential lessee should select the leasing arrangement with the greatest positive value. This requires an analysis of the direct cash flow from leasing for each of the leasing arrangements available.

For example, suppose that a firm has two leasing arrangements available to lease a given asset. The direct cash flow from leasing is shown below for each alternative:

| End of Year | Direct Cash Flow from Leasing | |
|-------------|-------------------------------|----------|
| | Lease 1 | Lease 2 |
| 0 | \$42,000 | \$45,800 |
| 1 | (15,000) | (13,000) |
| 2 | (15,000) | (16,000) |
| 3 | (15,000) | (18,000) |
| 4 | (1,000) | (4,000) |

The value of the lease using an adjusted discount rate of 6% and 8% is summarized below:

| Adjusted Discount Rate | Value of | |
|------------------------|----------|---------|
| | Lease 1 | Lease 2 |
| 6% | \$1,109 | \$1,015 |
| 8 | 2,663 | 2,818 |

When the adjusted discount rate is 6%, both leases are economically beneficial. However, Lease 1 is marginally superior to Lease 2. The value of both leases increases when the adjusted discount rate is 8%. In this case, Lease 1 is slightly less attractive than Lease 2. The NPVs of both leases for discount rates ranging from 4% to 10% are shown in Figure 17.2.

Another Approach to Lease Valuation

Rather than determining the NPV of a lease, many lessors use a different approach when attempting to demonstrate to potential lessees the economic

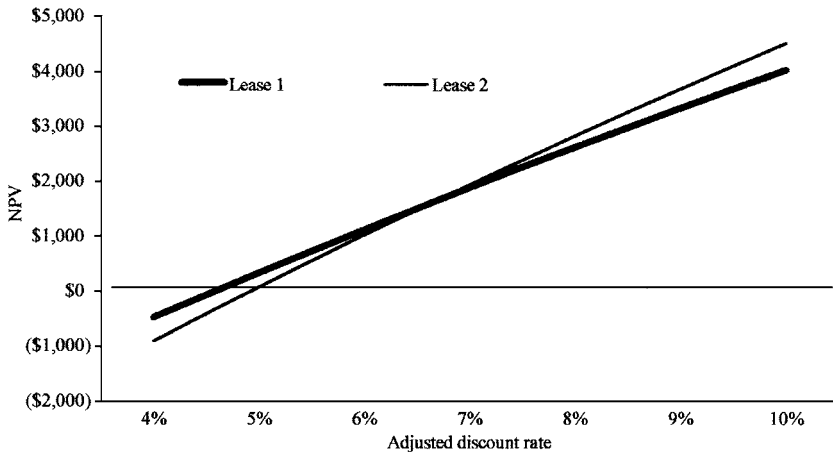
FIGURE 17.2 The NPV of Lease 1 and Lease 2 for Different Adjusted Discount Rates

attractiveness of a particular leasing arrangement. The approach is a comparison of the after-tax interest rate on the lease with the after-tax cost of borrowing money. The reason this approach appears to be popular is that management finds it easy to comprehend a rate concept but difficult to appreciate the NPV-of-a-lease concept.

The after-tax interest rate on the lease is found by determining the discount rate that equates the direct cash flow from leasing to zero; that is, it is the discount rate that makes the value of the lease equal to zero. This discount rate is also referred to as the *internal rate of return*. The after-tax interest rate on the lease is then compared to the after-tax cost of borrowing money. When the after-tax interest rate on the lease exceeds the after-tax cost of borrowing money, borrowing to purchase is more economical than leasing. Leasing is more economical when the after-tax cost of borrowing money is greater than the after-tax interest rate on the lease.

Table 17.1 shows the direct cash flow from leasing for the lease arrangement available to the Hieber Machine Shop Company. The discount rate that produces a present value close to zero for the direct cash flow from leasing is 6.3%. Hence, the after-tax interest rate on the lease is about 6.3%.

When the after-tax cost of borrowing is 6%, the lease arrangement is not attractive. However, when the after-tax cost of borrowing money is 8%, the lease arrangement is attractive.

In the previous illustration, the determination that was made as to whether the lease was economically attractive was precisely the same determination that was made when the NPV lease valuation model was used.

That the results are identical is not peculiar to this illustration. The two approaches will always produce the same result.

The advantage of the NPV lease valuation model presented is that it permits interaction of the investment and financing decisions. As a result, it is simple to determine whether an investment proposal that has a negative NPV assuming normal financing can be made economically attractive by a favorable lease arrangement. With the after-tax interest on the lease approach, this is not done as easily. That approach requires management to revise its estimate of the cost of capital when the after-tax interest rate on the lease is less than the after-tax cost of borrowing money and then to reevaluate the investment proposal with the revised cost of capital. This is an extremely complicated and awkward approach since it requires a continuous revision of the cost of capital as attractive lease arrangements become available. No simple solution to this problem has been proffered in the literature.

The rate approach will not always provide the same solution as the NPV approach when lease arrangements are compared. Differences in the selection of the best lease arrangement may result when the number of advance payments is different, when the lease payments are not uniform, or when the tax credit is handled any differently. The best lease arrangement is the one with the greatest NPV. Therefore, if conflicts arise when comparing lease arrangements by the two methods, the decision should be based on the NPV of the lease.

Tax Indemnification for Future Changes in Tax Law

Where a company intends to use a true lease to finance the acquisition of equipment it needs, the lessee and lessor must agree as to which of them will bear the burden of future tax changes. The major tax benefits available to a lessor consist of MACRS-accelerated depreciation deductions. During the early years of a lease, tax deductions attributable to accelerated depreciation equal all or part of taxable rental income. This results in deferral of taxable income attributable to the lease rentals until the later years of the lease when depreciation deductions decline or are exhausted. If in the early years of a lease, the tax rate rises above that assumed by the lessor for pricing, the lessor's cash flows and yield will rise accordingly during those early years in which the lessor claims depreciation deductions. However, if the tax rate is higher than assumed by the lessor for pricing during the later years in which the rental income exceeds the depreciation deductions, the lessor's cash flow and yield will decline or even disappear.

Lessors generally take the position that they should be held harmless by the lessee in the event of any tax law changes or tax rate changes adversely affecting their contemplated yield or cash flow. Lessors argue that the lessee

is no worse off under such an indemnification than the lessee would have been had the lessee purchased the leased equipment and directly claimed tax benefits associated with equipment ownership. Lessees, however, generally take the position that after delivery of the leased equipment, lessors should assume the risk of loss of tax benefits for any reason except as a result of acts or omissions of the lessee.

The problem facing both lessees and lessors is how to engage in equipment leasing and protect themselves in view of the future tax rate and tax law uncertainties. A significant tax rate change can have disastrous consequences for a lessor, and the possibility of such a change is very real.

Initial questions facing lessors and lessees include the following:²⁷

- What is the definition of the tax-law risk and tax-rate risk covered by the indemnity?
- What risk of tax-rate change needs to be covered?
- What event or events will trigger a tax indemnity?
- For what period of time will tax indemnities apply? For the entire lease? Or for a limited number of months or years?
- How will the loss (or gain) resulting from indemnified tax rate risks be computed?
- How will the indemnified party be compensated?
- Under what circumstances can the lessee or lessor terminate the lease?

Need for a Financial Adviser

An initial question for a company considering a leveraged lease is to determine its need for a financial adviser or broker.²⁸ Basically, this question boils down to whether the services performed by a financial adviser will be cost effective as compared to the expenditure for the financial adviser's fee.

The services to be performed by a financial adviser for a company securing a leveraged lease include some or all of the following:

- Advise the company in structuring financing of the planned equipment acquisition:

²⁷ For a further discussion of each, see Chapter 16 in Nevitt and Fabozzi, *Equipment Leasing*.

²⁸ Generally the lessee's financial adviser will locate the equity and/or debt investors and thus perform the brokerage function. From the standpoint of the investor and in the parlance of the trade, the lessee's financial adviser is a broker.

- Understand the company's objectives, priorities, and constraints.
 - Analyze the tax, legal, accounting, and economic consequences for the company as well as the potential market acceptance of alternative approaches.
 - Meet and work with the company's legal and tax counsel with regard to the proposed financing.
 - Consider alternative methods of financing and compare their advantages and disadvantages with lease financing.
 - If leasing is the best alternative, recommend the optimal lease financing strategy.
- Assist the company in establishing a realistic transaction timetable, ensuring that all aspects of the financing progress in a timely and systematic fashion.
 - Assist the company in preparing an equity offering memorandum describing the transaction for distribution to prospective equity sources.
 - Identify the most appropriate equity investors for the transaction.
 - Solicit commitments on a consistent basis from prospective equity participants so as to ensure a complete underwriting of the equity investment in the transaction. Arrange meetings and make face-to-face presentations with priority prospects to explain the transaction.
 - Arrange meetings between the company's key executives and priority prospects where that is advisable.
 - Review, rank, and clarify the equity responses for the company. Evaluate the economics of the equity commitments, including all relevant terms and conditions. Assist the company in selecting the best equity investor(s).
 - Assist the company in negotiating and completing the commitment letter and any pricing adjustments with the equity participants.
 - Arrange for the private placement of the leveraged debt or assist in doing so. Advise the company with regard to structuring the leveraged debt to achieve optimal pricing, amortization, and flexibility, as well as favorable terms and conditions.
 - In conjunction with the company and its counsel, negotiate and document the terms and conditions of the various leveraged-lease documents.
 - Assist in the closing of the transaction.

In order to proceed without a financial adviser, a prospective lessee must be satisfied that:

- It has the technical and professional expertise to perform the above services with its own staff.

- Those persons on its staff with the technical ability and expertise to arrange a lease can devote the time necessary to arrange, negotiate, and complete the transaction as successfully as would a financial adviser.
- It can gain access to the lease equity and/or debt placement markets as effectively and competitively as can a financial adviser.

Some companies that have regularly used leveraged leases to finance equipment feel comfortable with arranging additional leveraged leases themselves, particularly when the additional leases are repetitious and very similar to what they have done in the past. While such companies undoubtedly have the expertise to structure and negotiate leveraged leases, the questions they must address are whether they are familiar enough with changing lease equity markets to be up-to-date with regard to the latest innovative developments in those markets and whether they will be able to identify the full range of potential investors and lenders. Often the newest entrants are the most aggressive bidders as they seek to quickly build their portfolios.

Steps in Structuring, Negotiating, and Closing a Leveraged Lease

We conclude this section with a description of the various steps and milestones in structuring, negotiating, and closing a leveraged lease:

- Review of the transaction by the lessee and its counsel.
- Preparation of drafts of the equity and debt-placement memos.
- Preparation of the equity and debt-placement offering memoranda with the lessee and its counsel.
- Preparation of equity and debt solicitation lists.
- Completion of the equity solicitation and receipt of firm commitments from selected equity sources.
- Completion and execution of the equity commitment letter.
- Completion of a draft of all documents to be required.
- Completion of debt solicitation and receipt of firm commitments from debt participants.
- Review of debt documents by the lessee and equity participants.
- Completion and execution of the debt commitment letter.
- Completion of negotiations and agreement as to documents by the lessee and equity participants.
- Review of documents by the debt participants.
- Completion of negotiations and agreement as to debt documents by the equity participants, the lessee, and the debt participants.
- Completion of final documents and signatures on all documents by all parties.

- Delivery of the leased equipment, acceptance by the lessee, and payment of the purchase price.

The timetable for accomplishing those steps varies with each transaction depending on the complexity of the structure, the strength of the lessee's credit, and the time remaining before the property to be leased is expected to be placed in service. While the placed-in-service date cannot in and of itself result in a rapid time schedule, it can motivate the parties to move with a greater sense of urgency than might otherwise be the case. As noted earlier, the lessee and the lessor can speed the process and hold down the costs by closely supervising their attorneys, segregating business decisions from legal decisions, and making business decisions promptly so that the documentation can move forward.

While it is possible to arrange a facility lease in a fairly short time, the financial planning for a large facility is complex and may involve a lead time extending over several months. Figure 17.3 is a flowchart for a facility leveraged-lease transaction showing the decisions that will be made and the events that will take place from the inception to the completion of such a transaction.

BOTTOM LINE

- A lease is a contract wherein, over the term of which, the owner of equipment (the lessor) permits another entity (the lessee) to use that equipment in exchange for a promise by the lessee to make a series of lease payments.
- The options available to the lessee at the end of the lease term are critical in determining the nature of the lease for tax purposes and the classification of the lease for financial accounting purposes.
- Nontax-oriented leases or conditional sale leases transfer substantially all of the benefits and risks incident to the leased property to the lessee and usually give the lessee a fixed-price bargain purchase option or renewal option that is not based on fair market value at the time of exercise. For tax purposes, the transaction is treated as a loan.
- In a tax-oriented true lease, the lessor claims and retains the tax benefits of ownership and passes through to the lessee most of such tax benefits in the form of reduced lease payments. The principal advantage to a lessee of using a true lease to finance an equipment acquisition is the economic benefit that comes from the indirect realization of tax benefits that might otherwise be lost because the lessee cannot use the tax benefits.

FIGURE 17.3 Critical Path Chart of Leveraged Lease Financing for a Large Manufacturing Facility

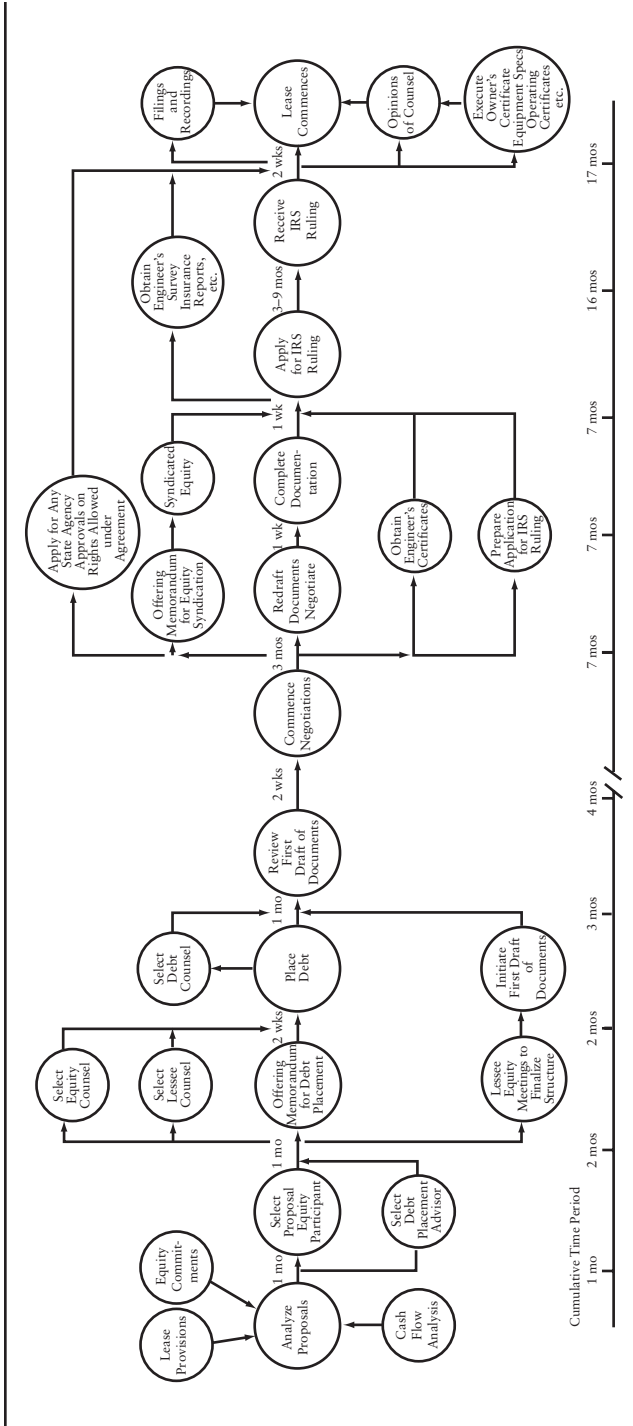

Source: Exhibit 1 in Chapter 17 of Peter K. Neveit and Frank J. Fabozzi, *Equipment Leasing*, 4th ed. (Hoboken, NJ: John Wiley & Sons, 2000), p. 351.

- True leases are categorized as single-investor leases (or direct leases) and leveraged leases. Single-investor leases are essentially two-party transactions, with the lessor purchasing the leased equipment with its own funds and being at risk for 100% of the funds used to purchase the equipment. Conceptually, a leveraged lease of equipment is similar to a single-investor lease. However, it is more complex in size, documentation, legal involvement, and, most importantly, the number of parties (particularly lenders who provide the major portion of funds to purchase the equipment) involved and the unique advantages that each party gains.
- Full-payout leases are basically financing transactions. In contrast, an operating lease is one for which the lease term is much shorter than the expected life of the equipment.
- The reasons cited for leasing rather than borrowing to purchase equipment are cost savings, conservation of working capital, preservation of credit capacity by avoiding capitalization, elimination of risk of obsolescence and disposal of equipment, less restrictions on management, and flexibility and convenience. The relative importance of these factors varies by company and situation, particularly cost savings, since cost reduction depends on whether the lease is tax-oriented.
- For financial reporting purposes, a lease is classified as either an operating lease or a capital lease. FAS 13 sets forth the conditions for classifying a lease. For a capital lease, the transaction is shown on the lessee's balance sheet as a liability and the leased property reported as an asset. For an operating lease, the lessee need only disclose certain information regarding lease commitments in a footnote.
- The value of the lease is found by discounting the direct cash flow from leasing by the adjusted discount rate. A negative value for a lease indicates that leasing will not be more economically beneficial than borrowing to purchase. A positive value means that leasing will be more economically beneficial. However, leasing will be attractive only if the NPV of the asset assuming normal financing is positive and the value of the lease is positive, or if the sum of the NPV of the asset assuming normal financing and the value of the lease is positive.
- A leveraged lease is a true lease that allows a company, as lessee, to harness the lessor's capital, leveraged by institutional debt, as a source of funding somewhat like subordinated debt and involves a minimum of three parties with diverse interests: a lessee, a lessor, and a nonrecourse lender.
- The most attractive feature of a leveraged lease, from the standpoint of a lessee unable to use tax benefits of MACRS, is its low cost as compared to that of alternative methods of financing.

- The key document in a leveraged-lease transaction is the participation agreement, which, in effect, is a script for closing the transaction. Other key documents are the lease agreement, the owner trust agreement, and the indenture trust agreement.
- There are various indemnities a lessee provides in a leveraged lease and they are classified as general indemnities, general tax indemnities, and special tax indemnities.

Managing Short-Term Assets

AGENDA

- Item 1* Identify the factors that a CFO should consider in determining how much to invest in current assets.
- Item 2* Explain the reasons for cash forecasting and the reasons for holding cash balances.
- Item 3* Describe different cash management techniques.
- Item 4* Explain the reasons for holding market securities and the different types of marketable securities.
- Item 5* Explain the reasons why a firm extends credit, the different credit and collection policies that can be employed, and the procedures for monitoring accounts receivable.
- Item 6* Explain the reasons for holding inventory, the different models of inventory management, and techniques for monitoring inventory management.

As explained in the previous three chapters, managers base decisions about investing in long-term projects on judgments about future cash flows, the uncertainty of those cash flows, and the opportunity costs of the funds to be invested. In this chapter, we turn to the management of short-term assets. We will see that such decisions are made in similar ways, but over much shorter time horizons. Thus considerations of risk will take a smaller role in our discussions, while the operating cycle becomes more important.

The operating cycle refers to the time it takes to turn the investment of cash (e.g., buying raw materials) back into cash (e.g., collecting on accounts receivables). The operating cycle in part determines how long it takes for a firm to generate cash from its short-term assets and, therefore, the risk and cost of its investment in current assets, or working capital. *Working capital* is the capital that managers can immediately put to work to generate the benefits of capital investment. Working capital is also known as *current capital* or *circulating capital*.

Firms invest in current assets for the same reason they invest in long-term, capital assets: to maximize owners' wealth. But because managers evaluate current assets over a shorter time frame (less than a year), they focus more on their cash flows and less on the time value of money.

How much should a firm invest in current assets? That depends on several factors:

- The type of business and product.
- The length of the operating cycle.
- Customs, traditions, and industry practices.
- The degree of uncertainty of the business.

The type of business, whether retail, manufacturing, or service, affects how a firm invests. In some industries, large investments in machinery and equipment are necessary. In other industries, such as retail firms, less is invested in plant and equipment and other long-term assets, and more is invested in current assets such as inventory. For example, companies in the tobacco, distillery, and lumber industries typically have operating cycles greater than one year, whereas retailers tend to have operating cycles much shorter than one year.¹

The company's *operating cycle*—the time it takes the company to turn its investment in inventory into cash—affects how much the firm ties up in current assets. The operating cycle is the sum of the number of days it takes to convert the investment in inventory into a sale, referred to as the *days sales in inventory (DSI)*, and the number of days it takes to collect on credit extended to customers, which is referred to as the *days sales outstanding (DSO)*:

$$\text{Operating cycle} = \text{DSI} + \text{DSO}$$

The days sales in inventory, also referred to as the *number of days of inventory*, is the ratio of the inventory to the average day's cost of goods sold:

$$\text{DSI} = \frac{\text{Inventory}}{\text{Average day's cost of goods sold}} = \frac{\text{Inventory}}{\text{Cost of goods sold}/365}$$

The days sales outstanding, also referred to as the *number of days of credit* or *average collection period*, is the ratio of the accounts receivable to the average credit sales per day:

$$\text{DSO} = \frac{\text{Accounts receivable}}{\text{Credit sales per day}} = \frac{\text{Accounts receivable}}{\text{Credit sales}/365}$$

¹ The tobacco, distillery, and lumber industries were specifically cited in Accounting Research Bulletin No. 43, which addressed the issue of the classification of assets and liabilities as current.

Therefore, the operating cycle is the length of time that cash is tied up in working capital accounts, based on the average sales and credit collection activity.

The *net operating cycle* is the operating cycle, adjusted for the benefit from trade credit. The fact that a company does not pay for its supplies immediately makes more cash available for the company, offsetting the need that the company may have from its investment in inventory and accounts receivable. The net operating cycle or *cash conversion cycle (CCC)* is the operating cycle less the days payables outstanding:

$$\text{CCC} = \text{DSI} + \text{DSO} - \text{DPO}$$

Days payables outstanding (DPO) is the ratio of accounts payable to the average day's purchases:

$$\text{DPO} = \frac{\text{Accounts payable}}{\text{Purchases per day}} = \frac{\text{Accounts payable}}{\text{Purchases} / 365}$$

The longer that the company takes to pay on its accounts, the greater the DPO and, hence, the shorter the cash conversion cycle. The CCC, therefore, provides a metric of how long cash is tied up in working capital accounts, considering the company uses trade credit with its suppliers. The greater the CCC, the greater the opportunity cost associated with the working capital investment.

The working capital decision requires an evaluation of the benefits and costs associated with each component. In this chapter, we will look at the management of cash, marketable securities, receivables, and inventory and see how we can evaluate the benefits and costs associated with the investment in these assets.

CASH MANAGEMENT

Cash flows out of a firm as it pays for the goods and services it purchases from others. Cash flows into the firm as customers pay for the goods and services they purchase. When we refer to *cash*, we mean the amount of cash and cash-like assets—currency, coin, and bank balances. When we refer to *cash management*, we mean management of cash inflows and outflows, as well as the stock of cash on hand.

Monitoring Cash Needs

The CFO's staff can monitor cash needs through cash forecasting. *Cash forecasting* is analyzing how much and when cash is needed, and how much

and when to generate it. Cash forecasting requires pulling together and consolidating the short-term projections that relate to cash inflows and outflows. These cash flows may be a part of the capital budget, production plans, sales forecasts, or collection on accounts.

To understand the cash needs and generation, the CFO must understand how long it takes to generate cash once an investment in inventory is made. In other words, the CFO must understand the company's operating and net operating cycles, which affect the company's need and availability of working capital.

Estimating the net operating cycle gives the CFO information on how long it takes to generate cash from our current assets. The longer the net operating cycle, the more cash the company needs on hand.

To understand cash flows, the CFO must also have a fairly good idea of the uncertainty of our cash needs and cash generation. Cash flows are uncertain because sales are uncertain, and so is the uncertainty regarding when the company will collect payment on what it sells, as well as uncertainty about production costs and capital outlays. Forecasting cash flows requires the coordination of marketing, purchasing, production, and financial management.

Reasons for Holding Cash Balances

Firms hold some of their assets in the form of cash for several reasons. They need cash to meet the transactions in their day-to-day operations. Referred to as the *transactions balance*, the amount of cash needed for this purpose differs from firm to firm, depending on the particular flow of cash into and out of the firm. The amount depends on:

1. The size of the transactions made by the firm.
2. The firm's operating cycle, which determines its cash outflow and inflow, depending on the firm's production process, purchasing policies, and collection policies.

There is always *some* degree of uncertainty about future cash needs. Firms typically hold an additional balance, referred to as a *precautionary balance*, just in case transactions needs exceed the transactions balance. But how much to keep as a precaution depends on the degree of the transactions uncertainty—how well we can predict our transactions needs. For example, a retail store has a good idea from experience about how much cash to have on hand to meet the typical day's transactions. In addition to what is needed for a typical day, the retail store may keep more cash on hand to meet a higher-than-usual level of transactions.

In addition to the precautionary balances, firms may keep cash on hand for unexpected future opportunities. Referred to as a *speculative balance*, this is the amount of cash or securities that can be easily turned into cash, above what is needed for transactions and precaution. The speculative balance enables a firm to take advantage of investment opportunities on short notice and to meet extraordinary demands for cash. For example, an automobile manufacturer may need an additional cash cushion to pay its bills in case a wildcat strike closes down a plant.

In addition to the cash balances for transactions, precautionary, and speculative needs, a firm may keep cash in a bank account in the form of a *compensating balance*—a cash balance required by banks in exchange for banking services. By keeping a balance in an account that is non-interest earning or low-interest earning, the firm is effectively compensating the bank for the loans and other services it provides. Some bank loans and bank services require a specified amount or average balance be maintained in an account.

Costs Associated with Cash

There is a cost to holding assets in the form of cash. Because cash does not generate earnings, the cost of holding assets in the form of cash, referred to as the holding cost, is an opportunity cost—what the cash could have earned if invested in another asset.

If a firm needs cash, it must either sell an asset or borrow cash. There are transactions costs associated with both. Transactions costs are the fees, commissions, or other costs associated with selling assets or borrowing to get cash; they are analogous to the ordering costs for inventory.

Determining the Investment in Cash

How much cash should a CFO have a firm hold? For transactions purposes, it should be enough to meet the demands of day-to-day operations. To determine how much is enough for transactions purposes, the CFO compares the cost of having too much cash to the cost getting cash—in other words, the CFO compares the holding cost and transactions cost.

As more cash is held, its holding cost increases. With more cash on hand, the costs of making transactions to meet the firm's cash needs for operations declines. That's because with larger cash balances, the firm needs fewer transactions (selling marketable securities or borrowing from a bank) to meet cash needs.

The CFO wants to have on hand the amount of cash that minimizes the sum of the costs of making transactions to get the cash (selling securities or borrowing) and the opportunity cost of holding more cash than needed.

There are several models that are suggested to help answer that question. We will not discuss them here.²

The basic idea of these models is dealing with the trade-off among costs and benefits of different levels of cash on hand. For example, the model developed by William Baumol helps the financial manager determine the level of cash that minimizes the sum of the holding costs—which increase with greater levels of cash on hand—and transactions costs—which decrease with greater levels of cash on hand. A variation on this model is the model by Merton Miller and Daniel Orr. In their model, a balance hitting upper and lower limits on balances elicits investment or borrowing transactions to keep the balance in the account within these limits.

Other Considerations

There are other factors that affect cash management. One is the seasonality of cash needs. If sales and collections on sales are seasonal, we must factor the pattern of cash into the cash balance—the Baumol model does not consider changing cash needs.

Another factor is doing business in other countries. If a firm does business in a foreign country, complications are added, including:

- Keeping cash in different currencies.
- Restrictions on transferring currencies across borders.
- Laws in many countries requiring holdings in that country's domestic currency.
- The risk that the value of the foreign currency may change, relative to the company's domestic currency.

The CFO must look very closely at the firm's cash flows and the factors that affect the firm's cash needs. Once the CFO understands the firm's cash flow needs and the predictability of these needs, the basis of a cash model to determine cash infusions and holdings to minimize costs can be used.

Cash Management Techniques

Cash management has very simple goals:

- Have enough cash on hand to meet immediate needs, but not too much.

² William J. Baumol, "The Transactions Demand for Cash: An Inventory Theoretic Approach," *Quarterly Journal of Economics* (November 1952), and Merton H. Miller and Daniel Orr, "A Model of the Demand for Money by Firms," *Quarterly Journal of Economics* (July 1966), pp. 413–435.

- Get cash from those who owe it to the company as soon as possible and pay it out to those the company owes as late as possible.

The various models may help CFOs manage cash to satisfy the first goal. But the second goal requires methods that speed up incoming cash and slow down outgoing cash. To understand these methods, the CFO needs to first understand the check clearing process.

The process of receiving cash from customers involves several time-consuming steps:

- The customer sends the check.
- The check is processed within the firm—so the customer can be credited with paying.
- The check is sent to the firm's bank.
- The bank sends the check through the clearing system.
- The firm is credited for the amount of the check.

Several days may elapse between the time when the firm receives the check and the time when the firm is credited with the amount of the check. During that time, the firm cannot use the funds. The amount of funds tied up in transit and in the banking system is referred to as the *float*. The float occurs because of the time tied up in the mail, in check processing within the firm, and in check processing in the banking system.

The float can be costly to those who are on the receiving end. Suppose on average customers make \$1 million in payments each day. If the float is seven days, 7 times \$1,000,000 = \$7,000,000 is coming to the company that it cannot use. If the company can speed up collections to five days, the float is \$5 million—and the freed-up \$2 million can be used for other things.

But the float can be beneficial to the payer. Suppose the company makes payments to suppliers, on average, \$1 million per day. And suppose it takes suppliers five days after they receive checks to complete the check processing system. The company has \$5 million in float per day. If the company could slow down the check processing by one day, this increases the float to \$6 million. That's \$1 million more cash available to use each day.

There are several ways to speed up incoming cash:

- *Lockbox system*: A system where customers send their checks to post office boxes and banks pick up and begin processing these checks immediately.
- *Selection of banks*: Choosing banks that are well connected in the banking system, such as clearinghouse banks or correspondent banks, can speed up the collection of checks.

- *Check processing within the firm:* Speed up processing of checks within the firm so that deposits are made quickly.
- *Electronic collection:* Avoid the use of paper checks, dealing only with electronic entries.
- *Concentration banking:* The selection of a bank or banks that are located near customers, reducing the mail float.

A *clearinghouse* is a location where banks meet to exchange checks drawn on each other, and a *clearinghouse bank* is a participant in a clearinghouse. Clearinghouses may involve local banks or local and other banks. Being a member of a clearinghouse can reduce check clearing time by up to one-half day relative to clearing checks through the Federal Reserve system. A *correspondent bank* is a bank that has an agreement with a clearinghouse bank to exchange its checks in the clearinghouse. Banks can become correspondents to clearinghouses in other parts of the country, reducing their check clearing time relative to clearing checks through the Federal Reserve system.

In addition, there are several methods a company can use to slow up its payment of cash:

- *Controlled disbursements:* Minimizing bank balances by depositing only what is needed to make immediate demands on the account.
- *Remote disbursement:* Paying what is owed with checks drawn on a bank that is not readily accessible to the payee, increasing the check processing float.

Whichever way the CFO elects to speed up the receipt of cash or slow down the payment of cash there is a cost. The CFO must weigh the benefits with the cost of altering the float.

We will look closely at one speedup device—the lockbox system—and one slow-down device—controlled disbursements—to see how the float can be altered.

Lockbox System

With a *lockbox system* a firm's customers send their payments directly to a post office box controlled by the firm's bank. This skips the step where the firm receives and handles the check and paperwork (see Figure 18.1). The lockbox system can cut down on the time it takes to process checks in two ways. First, the firm can use post office boxes (and collecting banks) throughout the country, reducing the time a check spends in the mail—reducing the mail float. Second, because the bank processes the checks and

paperwork, the lockbox avoids the time the checks spend at the receiving firm—eliminating the time it takes to process checks in the firm. In addition to the time savings from using a lockbox system, using this as a means of collecting and depositing on customers' payments provides additional audit and control of the savings system.

To see the savings using a lockbox, suppose it can reduce our total float from eight to five days. If the firm collects \$1.5 million per year through the lockbox system, three days' worth of collections ($\$1,500,000/365 \times 3 \text{ days} = \$12,329$) freed up for investment during the year. If the firm can earn 6% a year investing in marketable securities, this amounts to an increase in earnings of $\$12,329 \times 0.06 = \740 . As long as the cost of the lockbox system is less than \$740 per year, there is a benefit to using it. Thus for the CFO to decide whether to use such a system involves comparing the benefit obtained from the lockbox system with the lockbox fees charged by the bank.

There are a couple of drawbacks to a lockbox system. Because the bank receives the check and documents, it takes longer for the firm to record who has paid—the bank must forward the documents to the firm. Also, customers may become confused, since payments are sent to the lockbox's address and all other correspondence is sent to the firm's business address.

Setting up a lockbox system requires the answers to several questions:

- How many lockboxes?
- Where to locate the lockboxes to cut down on mail time?
- Where to direct which customers to send their payments?

FIGURE 18.1 An Example of the Timeline Corresponding to a Lockbox System

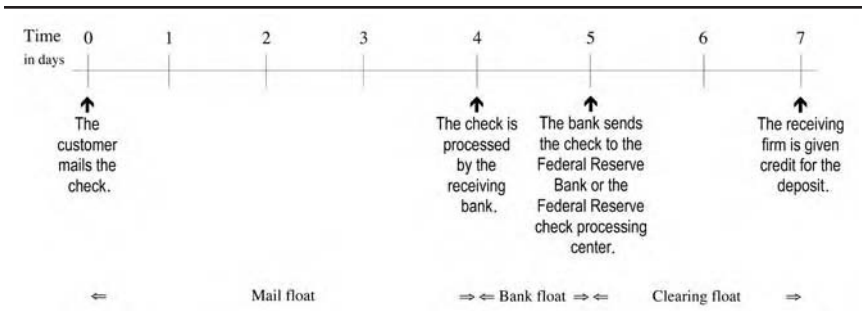

The lockbox system may reduce the mail float (due to the placement of the lockboxes near the customer) and changes what was the *firm float* to a *bank float* since the bank now processes the checks received from customers.

Determining the optimal lockbox setup requires evaluating the cost of each lockbox and the opportunity cost of having checks in the mail.

Current Advances in Lockboxes

There are a number of recent advances in lockbox systems that need to be considered in selecting a lockbox system, including:

- *Lockbox networks*—collections of banks that link lockboxes from different parts of the country to speed up the bank float.
- *Image-based processing*—computer coding, such as bar-coding of envelopes, that speeds up processing by the bank.
- *Mail interception*—banks picking up mail at the post office to reduce the mail float.
- *Nonbank lockbox systems*—firms other than banks that establish lockbox systems.

In selecting a lockbox system, the CFO needs to evaluate the speed with which the firm obtains access to funds, the recordkeeping of accounts paid, and the costs of the system.

Controlled Disbursements

If a CFO wants to have more cash available for the firm's use, the CFO can slow down the payments made—increasing the float to others. *Controlled disbursement* is an arrangement with a bank to minimize the amount that the firm holds in bank balances to pay what it owes. Under this system, the CFO minimizes the firm's bank balance to only the funds needed for immediate disbursing. To make this work, the CFO's staff needs to work closely with the bank—the bank notifies the CFO's staff of checks being cashed on the account and a staff member immediately wires the necessary funds.

An extreme disbursement method is referred to as a *zero-balance account (ZBA)*. In an ZBA arrangement, the firm keeps no funds in the bank—the CFO's staff simply deposits funds as the checks written out are presented for payment through the banking system. As this account can save two to three days of float and cost anywhere from \$20 to \$200 per month in bank fees, zero-balance accounts are attractive. Some banks will even automatically invest funds in excess of the firm's payments needs into short-term securities—ensuring that there are no idle funds.

A controlled disbursements system requires coordination between the CFO's staff and the firm's bank. If the staff is off just a little bit, the firm

can lose goodwill with its suppliers or other payees. Also, this system is not costless; the bank is performing a service and charges a fee.

How Much Cash Do Companies Really Hold?

Looking at how much cash companies actually do hold provides an interesting perspective on cash holdings. In annual surveys by *CFO* magazine and REL Consultancy Group, and measuring cash holdings relative to sales, companies on average hold cash balances around 10–11% of sales.³ However, the variations among industries are significant. For example, in 2004, companies in the biotechnology sector held 33.6% of sales in cash, whereas containers and packaging firms held, on average, 4.5% of sales in cash.

The trend over the years 2002 through 2006, for example, indicates that companies have ever-larger cash balances, exceeding the companies' operating needs. With such cash balances, companies face the issue of what to do with this excess cash. The choices include returning the cash to investors through share repurchases or special dividends, paying down debt, and using the cash in acquisitions.⁴

MARKETABLE SECURITIES

An integral part of cash management is storing excess cash in an asset that earns a return—such as marketable securities. Precautionary and speculative needs for cash can often be satisfied by funds stored in marketable securities, selling them as needs for cash arise. Models of cash management assume that CFOs stash cash they don't need right away into marketable securities and convert them to cash as needed. In this way, marketable securities are a substitute for cash.

If cash flows of a firm are uneven—perhaps seasonal—the CFO can deal with the uneven demands for cash by either borrowing for the short-term or selling marketable securities. If short-term borrowing is not possible or is costly, marketable securities can be used: Buy marketable securities when cash inflows exceed outflows; sell marketable securities when cash inflows are less than outflows. In this way, marketable securities are a temporary investment.

³ REL Consultancy Group and *CFO* magazine, “Stuck on Yellow: The 2005 Cash Management Scorecard,” *CFO*, October 3, 2005.

⁴ In the 2006 Cash Management Survey, Hackett-REL Consultancy Group and *CFO* magazine observe that companies paid down debt from 2004 to 2005, increasing the return on capital. (See David M. Katz, “Cash Scorecard: Unleash the Hoards?” *CFO*, October 17, 2006.)

Aside from the uneven cash demands from operations, marketable securities may be a convenient way for the CFO to store funds for planned expenditures. If the firm generates cash from operations or from the sale of securities for an investment in the near future, the funds can be kept in marketable securities until needed.

Marketable Securities and Risk

The primary role of marketable securities is to store cash that isn't needed immediately, but may be needed soon. The CFO should therefore consider only marketable securities that provide safety and liquidity. In evaluating safety, the CFO needs to look at the risks that the firm is accepting by investing in securities. The relevant risks for the CFO to consider are summarized in Table 18.1.

Types of Marketable Securities

The marketable securities that satisfy the criteria of safety and liquidity are most likely money market securities. Money market securities are listed and described in Table 18.2.

Some money market securities, such as government securities, have no default risk; the ones that do have very little default risk. Due to the short maturity of money market securities and the fact that they are generally issued by large banks or corporations (who are not likely to get into deep financial trouble in a short time), their default risk is low. Even so, anyone can look at the credit ratings by Moody's, Standard & Poor's, and Fitch for an evaluation of the default risk of a particular money market security.

TABLE 18.1 Risks Associated with Investing in Marketable Securities

| Risk | Description |
|------------------------|--|
| Default risk | The risk that the issuer will not pay interest and/or principal as promised. |
| Purchasing power risk | The risk that inflation will erode the purchasing power of the money received in the form of interest and principal in the future. |
| Interest rate risk | The risk that interest rates will rise, thereby changing the value of the investment. |
| Reinvestment rate risk | The risk that interest rates will fall, affecting the rate of return that can be earned by reinvesting the interest and principal from the investment. |
| Liquidity risk | Also referred to as <i>marketability risk</i> , the risk that the security will not be marketable, at least at its true value, due to the lack of investor interest in the security. |

TABLE 18.2 Money Market Securities

| Security | Description |
|-------------------------|---|
| Certificates of deposit | Debt issued by banks sold in large denominations. This debt has maturities ranging generally up to one year. Because this debt is issued by banks, but exceeds the amount for deposit guarantees by bank insurance, there is some default risk. |
| Commercial paper | Debt issued by large corporations that is sold in large denominations and generally matures in 30 days. While the debt is unsecured credit and is issued by corporations, there is some default risk, though this is minimized by the backup lines of credit at commercial banks. |
| Eurodollar deposits | Loans and certificates of deposits of non-U.S. banks that are denominated in the U.S. dollar. These debts are generally large denominations with maturities up to six months. Like loans and certificates of U.S. banks, there is some default risk. |
| Treasury bills | Securities issued by the U.S. government that have maturities of one month, three months, and six months. These securities are considered default-free and are readily marketable. |

Money market securities have relatively little purchasing power risk. The chance of inflation changing over the short horizon is slight, though a possibility. Money market securities also have relatively little interest rate risk. Since these securities are short-term, their values are not as affected by changes in interest rates as, say, a 30-year corporate bond.

The short maturities of money market securities, however, subject the investor to reinvestment rate risk. If rates fall and the security matures, the investor must roll over—or reinvest—the funds in another security with lower rates. But since this investment’s purpose is short-term, this is a risk that we must bear.

RECEIVABLES MANAGEMENT

The majority of a firm’s investment in current assets, however, is tied up in accounts receivable and inventory. Both the accounts receivable and inventory represent investments that are necessary for day-to-day operations of the business. We look at the management decisions involving extending credit (i.e., accounts receivable) in this section.

When a firm allows customers to pay for goods and services at a later date, it creates *accounts receivable*. By allowing customers to pay some time after they receive the goods or services, the firm is granting credit, which is referred to as *trade credit*. Trade credit, also referred to as *merchandise credit* or *dealer*

credit, is an informal credit arrangement. Unlike other forms of credit, trade credit is not usually evidenced by notes, but rather is generated spontaneously: Trade credit is granted when a customer buys goods or services.

Reasons for Extending Credit

Firms extend credit to customers to help stimulate sales. Suppose a firm offers a product for sale at \$20, demanding cash at the time of the sale. And suppose the firm's competitor offers the same product for sale, but allows customers 30 days to pay. Who is going to sell the product? If the product and its price are the same, the firm's competitor, of course. So the benefit from extending credit is the profit from the increased sales.

Extending credit is both a financial and a marketing decision. When a firm extends credit to its customers, it does so to encourage sales of its goods and services. The most direct benefit is the profit on the increased sales. If the firm has a *variable cost margin* (that is, variable cost/sales) of 80%, then increasing sales by \$100,000 increases the firm's profit before taxes by \$20,000. Another way of stating this is that the *contribution margin* (funds available to cover fixed costs) is 20%: For every \$1 of sales, 20 cents is available *after* variable costs.

The benefit from extending credit is:

$$\text{Benefit from extending credit} = \text{Contribution margin} \times \text{Change in sales}$$

If a firm liberalizes its credit it grants to customers, increasing sales by \$5 million, and if its contribution margin is 25%, the benefit from liberalizing credit is 25% of \$5 million, or \$1.25 million.

Costs of Credit

But as with any credit, there is a cost. The firm granting the credit is forgoing the use of the funds for a period—so there is an opportunity cost associated with giving credit. In addition, there are costs of administering the accounts receivable—keeping track of what is owed. And, there is a chance that the customer may not pay what is due when it is due.

Do firms grant credit at no cost to the customer? No, because as we just explained, a firm has costs in granting credit. So a firm generally gives credit with an implicit or hidden cost:⁵

⁵ These terms, in the form of a discount within a specified period and the full amount at another specified period of time, are referred to as ordinary terms. Other forms of credit terms include cash on delivery (COD), bill-to-bill, and cash before delivery (CBD).

- The customer that pays cash on delivery or within a specified time thereafter—called a discount period—gets a discount from the invoice price.
- The customer that pays after this discount period pays the full invoice price.

Paying after the discount period is really borrowing. The customer pays the difference between the discounted price and the full invoice price. How much has been borrowed? A customer paying in cash within the discount period pays the discounted price. So what is effectively borrowed is the cash price.

In analyses of credit terms, the dollar cost to granting a discount is:

$$\text{Cost of discount} = \text{Discount percentage} \times \text{Credit sales using discount}$$

If a discount is 5% and there are \$20 million credit sales using the discount, the cost of the discount is 5% of \$20 million, or \$1 million.

But wait: Is this the only effect of granting a discount? *Only* if it is assumed that when the firm establishes the discount it does not adjust the full invoice price of its goods. But is this reasonable? Probably not. If the firm decides to alter its credit policy to institute a discount, most likely it will increase the full invoice sufficiently to be compensated for the time value of money and the risk borne when extending credit.

The difference between the cash price and the invoice price is a cost to the customer—and, effectively, a return to the firm for this trade credit. Consider a customer that purchases an item for \$100, on terms of 2/10, net 30. This means if they pay within 10 days, they receive a 2% discount, paying only \$98 (the cash price). If they pay on day 11, they pay \$100. Is the seller losing \$2 if the customer pays on day 10? Yes and no. We have to assume that the seller would not establish a discount as a means of cutting price. Rather, a firm establishes the full invoice price to reflect the profit from selling the item *and* a return from extending credit.⁶

Suppose the Discount Warehouse revises its credit terms, which had been payment in full in 30 days, and introduces a discount of 2% for accounts paid within 10 days. And suppose Discount's contribution margin is 20%. To analyze the effect of these changes, the CFO's staff would have to project

⁶ If the customer pays within the discount period, there is a cost to the firm—the opportunity cost of not getting the cash at the exact date of the sale but rather some time later. With the terms 2/10 net 30, if the customer pays on the tenth day, the seller has just given a 10-day interest-free loan to the customer. This is part of the carrying cost of accounts receivable, which we will discuss in a moment.

the increase in Discount's future sales and how soon Discount's customers will pay.

Let's first assume that Discount does not change its sales prices. And let's assume that Discount's sales will increase by \$100,000 to \$1,100,000, with 30% paying within 10 days and the rest paying within 30 days. The benefit from this discount is the increased contribution toward before-tax profit of $\$100,000 \times 20\% = \$20,000$. The cost of the discount is the forgone profit of 2% on 30% of the \$1.1 million sales, or \$6,600.

Now let's assume that Discount changes its sales prices when it institutes the discount so that the profit margin (available to cover the firm's fixed costs) after the discount is still 20%:

$$\text{Contribution margin}(1 - 0.02) = 20\%$$

$$\text{Contribution margin} = \frac{0.20}{(1 - 0.02)} = 20.408\%$$

If sales increase to \$1.1 million, the benefit is the difference in the profit,

| | | | |
|---------------------|--------------------------|---|-----------|
| Before the discount | = 20% of \$1,000,000 | = | \$200,000 |
| After the discount | = 20.408% of \$1,100,000 | = | \$224,488 |

so the incremental benefit is \$24,488. And the cost in terms of the discounts taken is 2% of 30% of \$1,100,000, or \$6,600.

While we haven't taken into consideration the other costs involved (such as the carrying cost of the accounts and bad debts), we see that we get a different picture of the benefits and costs of discounts depending on what the firm does to the price of its goods and services when the discount is instituted. So what appears to be the "cost" from the discounts doesn't give us the whole picture, because the firm most likely changes its contribution margin at the same time to include compensation for granting credit. In that way, it increases the benefit from the change in the policy.

There are a number of costs of credit in addition to the cost of the discount. These costs include:

- The carrying cost of tying up funds in accounts receivable instead of investing them elsewhere.
- The cost of administering and collecting the accounts.
- The risk of bad debts.

The carrying cost is similar to the holding cost that we looked at for cash balances: the product of the opportunity cost of investing in accounts receiv-

able and the investment in the accounts. The opportunity cost is the return the firm could have earned on its next best opportunity. The investment is the amount the firm has invested to generate sales. For example, if a product is sold for \$100, and its contribution margin is 25%, the firm has invested \$75 in the sold item (in raw materials, labor, and other variable costs).

Suppose the CFO liberalizes the firm's credit policy, resulting in an increase in accounts receivable of \$1 million. And suppose that this firm's contribution margin is 40% (which means its variable cost ratio is 60%). The firm's increased investment in accounts receivable is 60% of \$1 million, or \$600,000. If the firm's opportunity cost is 5%, the carrying cost of accounts receivable is:

$$\text{Carrying cost of accounts receivable} = 5\% \text{ of } \$600,000 = \$30,000$$

We can state the carrying cost more formally as:

$$\text{Carrying cost of accounts receivable} = (\text{Opportunity cost})(\text{Variable cost ratio})(\text{Change in accounts receivable})$$

In addition to the carrying cost, there are costs of administering and collecting accounts. Extending credit involves recordkeeping. Moreover, costs are incurred in personnel and paperwork to keep track of which customers owe what amount. In addition to simply recording these accounts, there are expenses in collecting accounts that are past due. Whether the firm collects its own accounts or hires a collection agency to collect these accounts, there are costs involved in making sure that customers pay.

Still another cost of trade credit is unpaid accounts—bad debts. If the firm demanded cash for each sale, there would be no unpaid accounts. By allowing customers to pay after the sale, the firm is taking on risk that the customer will not pay as promised. And by liberalizing the firm's credit terms (for example, allowing longer to pay) or to whom it extends credit, the CFO may attract customers who are less able to pay their obligations when promised.

Credit and the Demand for a Firm's Goods and Services

When the CFO's staff decides to grant credit, it must consider the effect on the firm's pricing and its sales. Let's return to the case where the firm's competitor offers credit terms of payment in 30 days and the CFO's firm does not. While on the surface it may seem that the firm's competitor has an advantage, this might not be. What if the firm's competitor also charges higher prices? Perhaps these prices are just high enough to compensate it for the expected costs of bad debts and the time value of money. Does this mean that

the CFO's firm will increase sales if it extends credit? Yes, if the firm does not change its prices; maybe, if the firm increases prices when it extends credit.

To analyze the effect of extending credit, there are a number of factors to consider:

- *The price elasticity of goods and services.* How price sensitive are sales?
- *The probability of bad debts.* When the firm extends credit, how likely is it that some customers may pay late or never pay? How much compensation does the CFO require to bear this risk?
- *When customers are most likely to pay.* If the firm offers discount terms, will all its customers pay at the end of the discount period? What proportion of its customers will pay within the discount period?

As can be seen, there are many variables the CFO's staff must consider and these variables differ from firm to firm and industry to industry. An understanding of the firm's product market and of its customers' needs is required in analyzing the effects of a change in credit policy. In a survey of credit policies among companies, the Credit Research Foundation found that 57.7% of companies offered cash discounts, though the practice varies by industry.⁷ For example, 85.2% of firms in the chemical and allied products industry offer discounts, yet 50% of firms in the printing and publishing industry offer discounts. Further, companies do not tend to vary the amount of the discount as interest rates or market conditions change.

Credit and Collection Policies

A firm's credit and collection policies specify the terms of extending credit, deciding who gets credit, and procedures for collecting delinquent accounts. In deciding what its credit and collection policies will be, a firm considers the trade-off between the costs of accounts receivable—the opportunity cost of investing in receivables, the cost of administering the receivables, and the cost of delinquent accounts—and the benefits of accounts receivable—the expected increase in profits and the return received from its trade credit.

Credit terms consist of the maximum amount of credit, the length of period allowed for payment (that is, the net period), and the discount rate and discount period, if any. The purpose of discounts is to attract customers, thereby increasing sales, and to encourage the early payment of accounts, thereby reducing the amount tied up in accounts receivable.

⁷ "Current Trends in the Practice of Administering Cash Discount and The Effect of Cash Discount on Days Sales Outstanding," Credit Research Foundation, July 2001.

Credit terms should somehow balance the marketing needs (increased sales) and the costs of these receivables (the cost of administration of receivables, the risk of bad debts, and the opportunity cost of funds). To design terms to meet the needs of the sales group, the CFO's staff must consider:

- *Customers' cash flow patterns.* (Do the firm's customers have seasonal cash flows? How long is the customers' operating cycle?) To accommodate customers with seasonal needs, credit terms using seasonal dating, where the discount period begins at the start of the customer's busy season, can be tailored accordingly.
- *The terms competitors are offering.*
- *The equitability of credit terms among customers.* Firms must be careful not to discriminate among customers. For example, different terms can be applied to customers with different credit risks, but there must be some basis for classifying them.

When evaluating a customer's creditworthiness, the following factors should be considered:

Capacity: Ability of the customer to pay.

Character: Willingness of the customer to pay debts.

Collateral: Ability of creditors to collect on bad debts if the customer liquidates its assets.

Conditions: The sensitivity of the customer's ability to pay to underlying economic and market factors.

Firms use the following sources of information to assess the creditworthiness of customers:

- Prior experience with the customer.
- The credit rating assigned by rating agencies and reports on the customer, such as those of Dun & Bradstreet and TRW.
- Contact with the customer's bank or other creditors.
- Analysis of the customer's financial condition.

In setting credit policies, the CFO's staff must consider the cost of these sources, such as fees for credit reports, as well as the costs of personnel and other resources in evaluating the information contained in the credit reports.

Collection policies specify the procedures for collecting delinquent accounts. Collection could start with polite reminders, continuing in progressively severe steps, and ending by placing the account in the hands of a

collection agency, a firm that specializes in collecting accounts. The following sequence is typical:

1. When an account is a few days overdue, a letter is sent reminding the customer of the amount due and the credit terms.
2. When an account is a month overdue, a telephone call is made reminding the customer of the amount due, the credit terms, and efforts to collect the account by letter.
3. When an account is two months overdue it is handed over to a collection agency.

In designing the collection procedures, the CFO's staff must keep in mind that aggressive efforts to collect may result in lost future sales. The staff also has to consider the customers' circumstances. For example, if the customer is in the midst of a labor strike, the firm may wish to avoid collection tactics that would be detrimental to its relationship with this particular customer.

Monitoring Accounts Receivable

The CFO's staff can monitor how well accounts receivable are managed using financial ratios and aging schedules. Financial ratios can be used to get an overall picture of how fast accounts receivable are being collected. Aging schedules, which are breakdowns of the accounts receivable by how long they have been around, help get a more detailed picture of collection efforts.

The CFO can get an idea of how quickly accounts receivable are being collected by calculating the days sales outstanding (DSO). This is an estimate of the length of time it takes to collect on customers' accounts, which can then be compared to credit policies.

The CFO can use this measure to evaluate the effectiveness of the firm's collection policies, comparing the number of days of credit with the net period allowed in with the credit terms. The information helps in cash forecasting since it tells how long before each credit sale turns into cash, on average.

But certain factors need to be considered in applying this measure. For example, if sales are seasonal, which accounts receivable balance should be used? Over what period should the CFO measure credit sales per day? The CFO must be careful when interpreting this ratio since both the numerator and denominator are influenced by the pattern of sales. For example, firms tend to select the end of their accounting year to be the low point of their operating cycle. This is when business is slowest, which means the lowest inventory level and, possibly, the lowest receivables. If the CFO evaluates receivables at a firm's year-end, he or she may not get the best measure of

collections. It is preferable (though not always possible) to look at quarterly or monthly averages of receivables.

Firms also monitor receivables using an aging schedule. Preparing an aging schedule allows the CFO to look at all our receivables and group them according to how long they were outstanding, such as 1 to 30 days, 31 to 40 days, and so on. For example,

| Number of Days Outstanding | Number of Accounts | Amount Outstanding |
|----------------------------|--------------------|--------------------|
| 1 to 30 days | 120 | \$320,000 |
| 31 to 40 days | 40 | 80,000 |
| 41 to 50 days | 10 | 18,000 |
| 51 to 60 days | 5 | 15,000 |
| over 60 days | 3 | 3,000 |

This schedule can represent the receivables according to how *many* there are in each age group or according to the *total dollars* the receivables represent in each age group. The higher the number of accounts or the number of dollars in the shortest-term groups, the faster the collection.

Looking at a breakdown of accounts receivable in an aging schedule allows the CFO to do the following:

- Estimate the extent of customers' compliance with credit terms.
- Estimate cash inflows from collections in the near future.
- Identify accounts that are most overdue.

Keep in mind that the age of receivables may change from month to month if credit sales change. For example, the 30–60-day-old accounts receivable may increase from June to July simply because credit sales increased from May to June—not because collections of receivables became slower.⁸

Establishing and Changing Credit Policies

The credit decisions involve trade-offs, the profit from the additional sales versus the costs of extending credit, as follows:

| Benefits | Costs |
|---|--------------------------------------|
| Increased profits from increased sales. | Opportunity cost of funds. |
| | Administration and collection costs. |
| | Bad debts. |

⁸ We will see in Chapter 23 how the aging schedule is useful in formulating cash budgets.

It is difficult to measure the benefit of extending credit or changing credit terms because there are many variables to consider: If the firm liberalizes its credit policy, extending credit to more customers, do the costs associated with this increased credit change? Most likely. Do they change in a predictable manner? Most likely not, because the CFO won't know the costs associated with these additional sales until the credit policy is changed.

Ideally, the CFO wants to design the firm's credit (and collection) policy so that the marginal benefits from extending credit equal its marginal cost of extending credit. At this point, the firm maximizes owners' wealth. But the benefits and costs are uncertain. The best the CFO can do in forecasting the benefits and costs from the firm's credit and collection policies is to learn from the firm's own experience (make changes and see what happens) or from the experience of others (look at what happens when a competitor changes its policies).

Accounts Receivable Management in Practice

The management of accounts receivable requires balancing the costs of extending credit with the benefits from increased sales. A significant part of the management of accounts receivable involves credit management. Some companies have brought together finance functions from throughout divisions and units, including accounts receivable management, into shared services centers, which provide centralized management of the function and offer some economies of scale.⁹ Other companies take the shared services idea a step further and use captive finance subsidiaries to provide economies of scale in the credit function. Other companies outsource credit management to other, specialized companies, which take over the credit granting and collection functions.¹⁰ However, it remains to be seen whether this will provide the hoped-for efficiencies.¹¹

Some companies also use trade credit insurance to reduce the risks associated with receivables. As explained in Chapter 8, trade credit insurance can be used to insure part or all of a company's receivables. In addition to reducing the risks borne by the company in lending to customers, in the case

⁹ See, for example, Alix Nyberg Stuart, "How General Mills Built a Finance Team of Champions," *CFO.com*, October 29, 2001.

¹⁰ Martin Hall, "A/R Outsourcing: Coming of Age in the New Millennium," *Business Credit*, February 2003, pp. 1–2.

¹¹ See, for example, Stephen Taub, "Outsourcing Finance Not Catching On," *CFO.com*, April 21, 2004, and Ben McLannahan, "Finance to Go," *CFO Europe*, November 28, 2005.

of companies that securitize their receivables it reduces the risk associated with the securities backed by trade receivables.¹²

INVENTORY MANAGEMENT

Inventory is the stock of physical goods for eventual sale. Inventory consists of raw material, work-in-process, and finished goods available for sale. There are many factors in a decision of how much inventory to have on hand. As with accounts receivable, there is a trade-off between the costs of investing in inventory and the costs of insufficient inventory. There's a cost of too much inventory and there's a cost of too little inventory.

Reasons for Holding Inventory

There are several reasons to hold inventory. The most obvious is that if a firm sells a product, it can't transact business without inventory. Another obvious reason is that goods cannot be manufactured instantaneously. If the firm manufactures goods, it will likely have some inventory in various stages of production. This is referred to as work-in-process.

The firm also may want to have some inventory of finished goods in case sales are greater than expected. Or the firm may want to hold some speculative inventory for dealing with events such as a change in the product or a change in the cost of the raw materials. For example, when Coca-Cola introduced "New Coke" to replace the "old" Coke, many retailers hoarded supplies of the original Coke product—since renamed "Classic Coke"—in anticipation of continued customer demand for the original product.

Further, some firms hold inventory to satisfy contractual agreements. For example, a retail outlet that is the sole distributor or representative of a product in a region may be required to carry a specified inventory of goods for sale.

The decision to invest in inventory involves, ultimately, determining the level of inventory such that the marginal benefits (such as providing for transactions and precautionary needs) equal the marginal cost (such as carrying costs). The level of inventory at which the marginal benefits equal the marginal cost is the owners' wealth-maximizing level.

¹² Marie Leone, "Trade-Credit Insurance: Balm for Bankers," *CFO.com*, September 29, 2005.

Costs Associated with Inventory

There are two types of inventory cost—the cost of holding inventory and the cost of obtaining more inventory,

The holding cost for inventory, also referred to as the *carrying cost*, is the cost of keeping inventory—storage, depreciation, and obsolescence—and the *opportunity cost* of tying up funds in inventory. The CFO's staff can estimate holding cost on a per-unit basis:

$$\text{Holding cost} = (\text{Average quantity})(\text{Holding cost per unit})$$

Replenishing inventory is costly. The firm must place orders and has to pay shipping charges for each order. These costs make up the *ordering cost*. Given a cost per order, ordering costs can be calculated as:

$$\text{Ordering cost} = (\text{Fixed cost per order})(\text{Number of orders per period})$$

The total cost of inventory is the sum of the holding cost and ordering cost:

$$\text{Total inventory cost} = \text{Holding cost} + \text{Ordering cost}$$

In the next section, we examine two models of inventory management to discover ways to decrease inventory costs while still maintaining adequate inventory on hand.

Models of Inventory Management

There are alternative models for inventory management but the basic idea for all of them is the same: Minimize inventory costs. We will look at two—the economic order quantity model and the just-in-time inventory model—to see how they minimize costs.

The Economic Order Quantity Model

The Economic Order Quantity (EOQ) model helps management determine what quantity of inventory to order each time we order so that total inventory costs throughout the period are minimized. The economic order quantity model assumes that:

- Inventory is received instantaneously.
- Inventory is used uniformly over the period.

- Inventory shortages are not desirable.

With these assumptions, firms can minimize the costs of inventory—the sum of the carrying costs and the ordering costs—by ordering a specific amount of inventory, referred to as the *economic order quantity*, each time they run out of inventory.

The financial manager can adjust the level of inventory from the economic order quantity model to include safety stocks of inventory, as well as lead times and tolerance for stockout.

We will not provide a mathematical treatment of the model. Suffice it to say that the EOQ model is useful in pointing out the trade-off between holding and ordering costs. But there are some problems applying it to actual inventory management. One problem is that it does not consider the possibility that inventory may be held in several locations. For example, if a firm has many retail outlets and regional warehousing, the model has to be altered to consider order quantities for the firm as a whole, each warehouse, and each store. Another problem is that there may be different types of inventory—raw materials, work-in-process, and finished goods—and many different goods, requiring EOQ models for each one. Still another problem is that EOQ is not useful in cases where the demand for inventory is seasonal. Furthermore, EOQ is not readily adapted to cases when quantity discounts are available.

Just-in-Time Inventory

The goal of the *just-in-time (JIT)* inventory model is to cut down on the firm's need to keep inventory on hand, coordinating the supply of raw materials with the production and marketing of the goods. In JIT, the raw materials are acquired only precisely when they are needed—just in time. The idea of JIT is to have zero inventory or as near zero as possible without adversely affecting production or sales. The goal of this strategy is to cut down on inventory costs:

- Holding less inventory, so that there are lower storage costs, lower levels of spoilage, and less risk of obsolescence.
- Coordinating with suppliers to minimize the cost of reordering inventory.

JIT requires coordination between a firm and its suppliers. To make JIT work, the CFO must have timely, reliable delivery of goods and materials. Further, the CFO must have a predictable production process so that input needs can be determined in advance, which requires a high degree of pro-

duction automation. In addition, demand must be predictable. If production is constantly modified to suit the demand for the firm's product, JIT will not work well or may not work at all.

JIT is a strategy of coordination between suppliers, production, and marketing to minimize the amount of inventory to the point where it is always possible to supply exactly what consumers demand. Supplies and raw materials are delivered only when needed for production. The firm produces only those items that are needed for anticipated demand. This requires lots of coordination and falls apart if there is poor quality in any one part of the process—a defective bolt can gum up the works.

JIT works hand in hand with two other management techniques, total quality control (TQC) and employee involvement (EI). TQC is the principle that quality goods and services be a goal of all efforts of the firm—production, accounting, marketing, and so on. Part of TQC is recognizing that some personnel of the firm are customers of other personnel. For example, the CFO's staff serves the production management by evaluating the expansion of the production facilities, whereas the accounting staff serves the CFO's staff, supplying financial data necessary for the CFO's evaluation of the expansion.

EI is the philosophy that employees at all levels should be involved in the firm's decision making. By participating in decision making, employees are able to understand and perform their tasks better. Also, employees make significant contributions to the decision-making process due to their unique perspective regarding the decision.

This management strategy of just-in-time inventory management is similar to the zero-balance account disbursements technique for cash management. Both are based on the idea that the CFO can reduce costs if a lower balance is carried. And both require coordination and planning to make them work.

However, because JIT works well only if the cost of placing orders is small, the benefits of JIT depend, in part, on the ordering cost. Also, JIT does not work well in an industry that is subject to supply shocks, which could leave the company with inventory shortfalls.

Other Considerations

The goal of both the EOQ and JIT is to minimize the costs of holding and ordering inventory. The EOQ model does this through the quantity of goods ordered that will minimize costs. JIT inventory management does this a bit differently, by focusing on the source of these costs and minimizing holding costs.

In addition to the holding and ordering costs, there are other considerations in determining the appropriate level of inventory. One consideration is taxes on inventory. For example, there may be a state tax based on the

value of inventory held as of a specified date, say December 31. In that case, the CFO would hold on that date the smallest amount of inventory that would not cause a shortage of goods for the firm's customers.

Another consideration is the possibility of expropriation. If the firm is doing business in another country, there may be a risk of that country's government expropriating the firm's goods. When doing business in other countries, the CFO must assess the risk of expropriation and, if high, minimize the firm's inventory holdings in that country.

Monitoring Inventory Management

The CFO can monitor inventory by looking at financial ratios in much the same way receivables are monitored. One of the metrics that can be used is the days sales in inventory (DSI). The DSI is an estimate of the length of time between the acquisition of raw materials or purchased inventory and the sale of this inventory.

Combined with an estimate of the demand for the firm's goods, this ratio helps the CFO in planning production and purchasing of goods. For example, automobile manufacturers keep a close watch on the number of days of autos on car lots. If there are more than is typical, they tend to offer rebates and financing incentives. If there are fewer than is typical, they may step up production.

Another way to monitor inventory is the inventory turnover ratio—the ratio of what the firm sells over a period (the cost of goods sold) to what the firm has on hand at the end of that period (inventory):

$$\text{Inventory turnover} = \frac{\text{Cost of goods sold}}{\text{Inventory}}$$

The inventory turnover ratio indicates, on average, how many times inventory flows through the firm—from raw materials to goods sold—during the period. If the typical inventory turnover for a firm is, say, five times, that means that the firm completes the cycle of investing in inventory and selling it five times in the year. If the turnover is above the typical, this may suggest a possible stockout. If the turnover is less than usual, this may suggest either that production is slower (resulting in relatively more work-in-process) or that sales are sluggish and perhaps need a boost from providing sales incentives or discounting prices.

The CFO must be careful, however, in interpreting these ratios. Because the production and sale of goods may be seasonal—and not always in sync—the value the CFO put into the calculations may not represent what is actually going on. Most firms select the lowest point in their seasonal pattern of activity as their fiscal year-end.

Consider a retail company that has inventory levels as follows for its four fiscal quarters:

| Quarter End | Inventory in Millions |
|--------------|-----------------------|
| March 31 | \$200 |
| June 30 | 250 |
| September 30 | 300 |
| December 31 | 180 |

The company ends its fiscal year on December 31, its lowest point in its seasonal activity. If this company's cost of goods sold for the fiscal year is \$750 million, the inventory turnover for the year using the year-end inventory level is \$750 million/\$180 million = 4.17 times and the days sales in inventory (DSI), is 87.6 days. Using the average inventory based on the four-quarters' levels, the inventory turnover is \$750 million/\$232.5 million = 3.23 times and the DSI is 113.15 days. While 4.17 and 3.23 are correct values for inventory turnover, the 3.23 times is probably more representative of the firm's management of inventory throughout the year. Likewise, while 87.6 and 113.15 days are both correct calculations for DSI, the 113.15 is more representative.

Also, interpretation of an inventory turnover ratio is not straightforward. Is a higher turnover good or bad? It could be either. A high turnover may mean that the firm is using its investment in inventory efficiently. But it might mean that the firm is risking a shortage of inventory. Not keeping enough on hand (relative to what is sold) incurs a chance of lost sales and customer goodwill. If a toy retailer, for example, runs out of stock on the hottest toy in the Christmas season, customers will shop elsewhere. Using inventory turnover ratios along with measures of profitability can give the CFO a better idea of whether the firm is getting an adequate return on its investment in inventory.

Inventory Management in Practice

More recent innovations have integrated cash management and inventory management. For example, in the mid-1990s, Dell Corporation changed its performance measurement focus to the cash conversion cycle and the relation between the CCC and the return on invested capital. The changes resulted in a system in which the production process begins the moment a customer orders and pays for a computer.¹³ In other words, Dell Corpora-

¹³ See Thomas Meredith, "Performance Measurement and Risk Management at Dell," *Performance-Measurement.Net*, September 1, 1998, and Stephen Barr, "Thomas Meredith—Dell Computer Corp." *CFO*, September 1, 1998.

tion collects on accounts as it invests in the inventory production. Combined with the use of trade credit for its supplies, this change resulted in a cash conversion cycle of negative 8 days, down from 40 days.

Another innovation in inventory management involves a system referred to as *Material Requirements Planning (MRP)*. MRP is an information system that coordinates sales closely with materials acquisition. As a development arising from MRP, *Enterprise Resource Planning (ERP)* software has become an important tool of the CFO that links finance with production, sales, and other departments.¹⁴ ERP software is a single software that connects and integrates many functions or departments within a company, including customer orders, production, receivables, and accounting. Though some companies have had difficulties in implementing such a system, there are a number of success stories as well.¹⁵

BOTTOM LINE

- The management of short-term assets involves decisions related to cash, marketable securities, accounts receivable, and inventory. Because short-term assets support the long-term investments of the firm, these working capital assets are linked to the firm's capital budgeting decision.
- The investment in working capital accounts can be evaluated relative to demand and needs for cash using the cash conversion cycle. The cash conversion cycle is the sum of the number of days of sales in inventory (DSI) and the number of days of sales outstanding in receivables (DSO), less the number of days of purchases outstanding (DPO). The longer the length of the cash conversion cycle, the greater the firm's investment in working capital.
- The common purpose of our decisions related to working capital accounts is to minimize the company's investment in the short-term asset. But in all cases, the CFO must be aware that some investment in the asset is necessary because the company incurs costs if there are shortages. A CFO must strike the right balance between the cost of having and not having the working capital asset. The "right balance" is different for each firm; each firm must assess its costs of having and not having the asset.

¹⁴ See Christopher Koch, "The ABCs of ERP," *CIO.com*, January 10, 2006, and Doug Bartholomew, "The ABC's of ERP," *CFO IT*, September 15, 2004.

¹⁵ For See Christopher Koch, "When Bad Things Happen to Good Projects," *CIO*, December 1, 2004; Andrew Osterland, "Blaming ERP," *CFO*, January 1, 2000; and, "Recipes for ERP Success," *The Manufacturer*, February 2003.

- Cash management involves the trade-off between the benefits from having enough cash to meet day-to-day operations and the costs of having cash (e.g., opportunity cost of funds and costs of getting and storing cash). There are models that may assist the CFO in determining the amount of funds to transfer in and out of cash.
- Marketable securities are a store of excess cash. A firm invests funds in marketable securities to have a ready, liquid source of cash. Marketable securities include U.S. Treasury bills, commercial paper, and certificates of deposit.
- Receivables management involves a trade-off between the benefits of increased sales and the costs of credit (for example, the opportunity cost of funds and defaults by credit customers).
- Credit and collection policies must be formulated to consider the benefits arising from increasing sales and the costs associated with extending credit.
- Inventory management involves a trade-off between the benefits of having sufficient inventory to meet demand and the costs of inventory (for example, the opportunity cost of funds, storage, and obsolescence).
- Models of inventory management, such as the economic order quantity model and the just-in-time technique, can be used to analyze and minimize the costs of inventory.

PART

Five

Cost and Managerial Accounting

Classifying Costs

AGENDA

- Item 1* Distinguish between costs, expenses, and losses.
- Item 2* Distinguish between direct and indirect costs.
- Item 3* Identify the three integral components of a product.
- Item 4* Distinguish between prime costs and conversion costs.
- Item 5* Define variable, fixed, and mixed costs and discuss the effects of changes in volume on these costs.
- Item 6* Classify costs by department, functional area, or period in which they are charged to income.
- Item 7* Analyze the relationship of costs to planning, controlling, and decision making.
- Item 8* Identify the differences between standard and budgeted costs, controllable and noncontrollable costs, and committed and discretionary fixed costs.
- Item 9* Describe the basic approaches to cost estimation for new products.

Cost is defined as the value of the sacrifice made to acquire goods or services, measured in dollars by the reduction of assets or incurrence of liabilities at the time the benefits are acquired. At the time of acquisition, the cost incurred is for present or future benefits. When these benefits are utilized, the costs become expenses.

Management is constantly faced with making choices among alternative courses of action. Information about various types of costs and their behavioral patterns is vital to effective decision making. Data can be visualized as being in one large cost accounting information pool that is routinely accessed for purposes of product costing and performance evaluation and managerial decision making. The cost accounting information pool, to provide optimum information, consists of past revenue and costs necessary for product costing and performance evaluation, as well as projected revenue and costs necessary for managerial decision making.

We can classify the cost data that may be found in the pool into various categories, according to

- Elements of a product
- Relationship to production
- Relationship to volume
- Ability to trace
- Department where incurred
- Functional areas (activities performed)
- Period charged to income
- Relationship to planning, controlling, and decision making

In this chapter we discuss each of these categories. At the end of this chapter, we explain the difficulties of estimating the cost of new products and the methodologies that can be employed.

ELEMENTS OF A PRODUCT

The cost elements of a product, or its integral components, are direct materials, direct labor, and factory overhead as illustrated in Figure 19.1. This classification provides management with information necessary for income measurement and product pricing.

Materials

Materials are the principal substances used in production that are transformed into finished goods by the addition of direct labor and factory over-

FIGURE 19.1 Elements of a Product

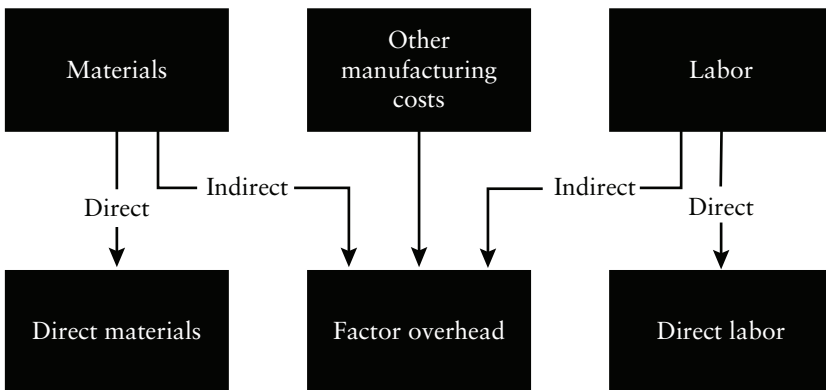

head. The cost of materials may be divided into direct and indirect materials. *Direct materials* are all materials that can be identified with the production of a finished product, that can be easily traced to the product, and that represent a major material cost of producing that product. An example of direct material is the lumber used to build a bunk bed. In contrast, *indirect materials* are all materials involved in the production of a product that are not direct materials. Indirect materials are included as part of factory overhead. An example of an indirect material is the glue used to build a bunk bed.

Labor

Labor is the physical or mental effort expended in the production of a product. Labor costs may be divided into direct and indirect labor. *Direct labor* consists of all labor directly involved in the production of a finished product that can be easily traced to the product and that represents a major labor cost of producing that product. The work of machine operators in a manufacturing company would be considered direct labor. *Indirect labor* is all labor involved in the production of a product that is not considered direct labor. Indirect labor is included as part of factory overhead. The work of a plant supervisor is an example of indirect labor.

Factory Overhead

Factory overhead is an all-inclusive cost pool used to accumulate indirect materials, indirect labor, and all other indirect manufacturing costs that cannot be directly identified with specific products. Examples of other factory overhead costs, besides indirect materials and indirect labor, are rental payments, utilities to operate the factory, and depreciation of factory equipment. Factory overhead costs can be further classified as fixed, variable, and mixed (definitions will be presented later in the chapter).

An Example of Production Costs

Consider an example of a company that incurs the costs shown in Table 19.1 in manufacturing wooden tables. The company's cost of direct materials would be \$260,000; direct labor is \$540,000, and factory overhead is \$142,800. These three figures represent the elements of the product, as we show in Table 19.2.

Not included as product costs are office rent of \$16,000, office salaries of \$80,000, and depreciation of office equipment of \$8,000. These office costs are not elements of a product and usually appear as deductions on the income statement from gross profit under the caption of "general and

TABLE 19.1 Costs for Manufacturing Wooden Tables

| Materials | |
|-----------------------------------|--------------------|
| Oak lumber | \$150,000 |
| Pine lumber | 110,000 |
| Glue | 800 |
| Screws | <u>1,000</u> |
| Total | \$261,800 |
| Labor | |
| Wood cutters | \$180,000 |
| Table assemblers | 190,000 |
| Sanders | 170,000 |
| Supervisor | 20,000 |
| Janitor | <u>10,000</u> |
| Total | \$570,000 |
| Other | |
| Factory rent | \$70,000 |
| Factory utilities | 20,000 |
| Office rent | 16,000 |
| Office salaries | 80,000 |
| Depreciation of factory equipment | 21,000 |
| Depreciation of office equipment | <u>8,000</u> |
| Total | \$215,000 |
| Grand total | \$1,046,800 |

administrative expenses.” The \$942,800 of total product cost will appear as the major component in a manufacturer’s cost of goods manufactured statement.

The classification of a cost based on its relationship to the product will change as the relationship changes. For example, lumber is a direct material cost when used in the manufacture of wood furniture. However, lumber is an indirect material cost when used as shipping crates for equipment. Maintenance personnel (e.g., janitors, custodians) in a manufacturing plant are an indirect labor cost; their function is not directly related to production. However, in a company that provides maintenance service to others, maintenance personnel would be considered a direct labor cost.

TABLE 19.2 Elements of a Product

| | Direct Materials | Direct Labor | Factory Overhead | Total Product Cost |
|--------------------------------------|---------------------|-----------------|---------------------|-----------------------|
| Oak lumber | \$150,000 | | | \$150,000 |
| Pine lumber | 110,000 | | | 110,000 |
| Glue | | | \$800 | 800 |
| Screws | | | 1,000 | 1,000 |
| Wood cutters | | \$180,000 | | 180,000 |
| Table assemblers | | 190,000 | | 190,000 |
| Sanders | | 170,000 | | 170,000 |
| Supervisor | | | 20,000 | 20,000 |
| Janitor | | | 10,000 | 10,000 |
| Factory rent | | | 70,000 | 70,000 |
| Factory utilities | | | 20,000 | 20,000 |
| Depreciation of factory equipment | | | 21,000 | 21,000 |
| Total | \$260,000 | \$540,000 | \$142,800 | \$942,800 |

RELATIONSHIP TO PRODUCTION

Costs may also be classified according to their relationship to production. This classification is closely related to the cost elements of a product (i.e., direct materials, direct labor, and factory overhead) and the major objectives of planning and control.

The two categories, on the basis of their relationship to production, are prime costs and conversion costs:

1. *Prime costs.* These costs are direct materials and direct labor. Prime costs are directly related to production.
2. *Conversion costs.* These are costs associated with transforming direct materials into finished products. Conversion costs are direct labor and factory overhead costs.

We diagram prime costs and conversion in Figure 19.2.

Note that direct labor is included in both categories. This does not result in double counting because this classification is used for planning and control, not for cost accumulation. For example, if the costs presented in Table 19.2 were classified according to their relationship to production, prime costs and conversion costs would be computed as follows:

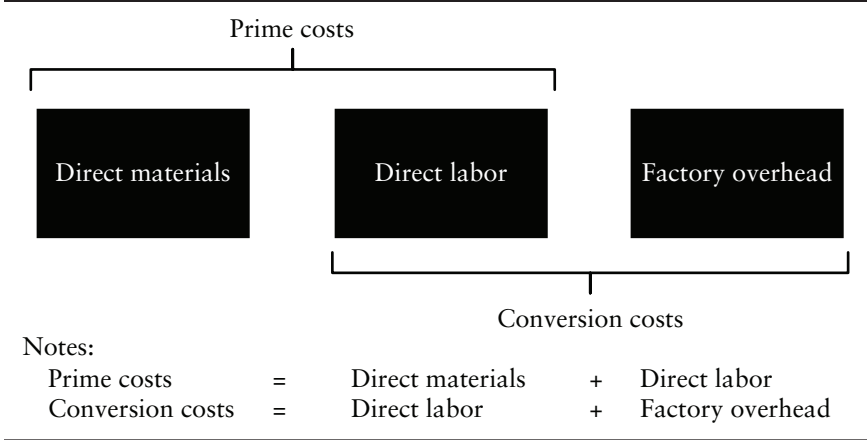
FIGURE 19.2 Prime Costs and Conversion Costs**Prime costs:**

| | |
|------------------|----------------|
| Direct materials | \$260,000 |
| Direct labor | <u>540,000</u> |
| Total | \$800,000 |

Conversion costs:

| | |
|------------------|------------------|
| Direct labor | \$540,000 |
| Factory overhead | <u>142,800</u> |
| Total | <u>\$682,800</u> |

RELATIONSHIP TO VOLUME

Costs vary with changes in the volume of production. Understanding their behavior is vital in almost all aspects of product costing, performance evaluation, and managerial decision making. Costs in relationship to volume are classified as variable, fixed, and mixed. However, the cost behavior patterns to be discussed are applicable only within a company's relevant range. The *relevant range* is defined as that interval of activity within which total fixed costs and per-unit variable costs remain constant.

Variable Costs

Variable costs are those in which the total cost changes in direct proportion to changes in volume, or output, within the relevant range, while the unit

cost remains constant. Variable costs are controlled by the department head responsible for incurring them. For example, if variable costs for direct materials are \$100 per unit of output, each time output increases by one unit, the variable cost for direct material increases by \$100.

In Figure 19.3, we illustrate the behavior pattern of total variable direct material costs based on \$100 per unit. The vertical axis represents dollar costs and the horizontal axis represents output. The line labeled “total variable costs” on the graph can be drawn by selecting a level of output and computing the corresponding dollar cost for that output. The slope represents the change in the dollar cost for a change in one unit of output; in other words, the slope is \$100, the variable cost.

The implication for management in its planning and controlling of variable costs is as follows: With all other factors held constant, such as selling price per unit and total fixed cost, each desired per-unit expansion of productive activity triggers an incremental change in total variable costs equal to a constant amount per unit. As long as the selling price per unit exceeds the variable cost per unit, productive activity should be expanded.

Fixed Costs

Fixed costs are those in which total fixed cost remains constant over a relevant range of output, while the fixed cost per unit varies with output. Beyond the relevant range of output, fixed costs will vary. Upper-level management controls the volume of production and is, therefore, responsible for fixed costs.

FIGURE 19.3 Pattern of Total Variable Direct Material Cost

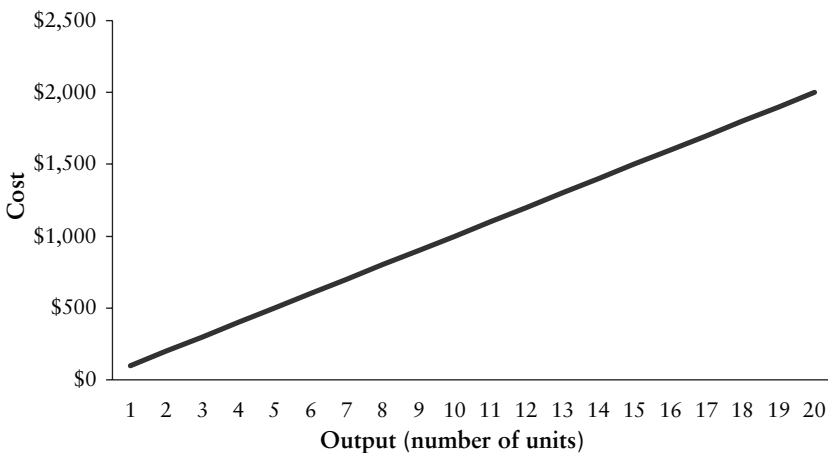

For example, assume that the total fixed cost for rent on a warehouse is \$20,000 a year if production is between 5 and 14.99 units. If production is expected to be less than 5 units, a smaller warehouse can be rented at \$15,000 a year. Therefore, two relevant ranges exist in this situation: relevant range A, covering from 0 to 4.99 units of output, and relevant range B, covering from 5 to 14.99 units of output.

In Figure 19.4 we present the behavior pattern of total fixed warehouse costs based on the preceding figures. In Figure 19.5 we present the behavior pattern of fixed cost per unit. In this figure, an output of 5 units would result in a fixed cost per unit of $\$20,000/5 = \$4,000$. If output were increased to 12 units, the fixed cost per unit would decrease to $\$20,000/12 \text{ units} = \$1,666.67$ per unit. The \$4,000 per unit and the \$1,666.67 per unit are *unitized fixed costs*—that is, fixed costs stated as a per unit cost. The change in fixed cost per unit in relation to changes in volume results in a downward sloping curve (as opposed to a straight line) because fixed costs per unit vary inversely with the activity level but do not change, in total, in direct proportion to changes in volume.

The implication for management in its planning and controlling of fixed cost is as follows: With all other factors held constant, such as selling price per unit and variable cost per unit, productive activity should be expanded as far as possible, which will reduce the fixed cost per unit to its lowest amount. This is the very essence of the important concept of fully utilizing

FIGURE 19.4 Pattern of Fixed Costs over Different Levels of Output

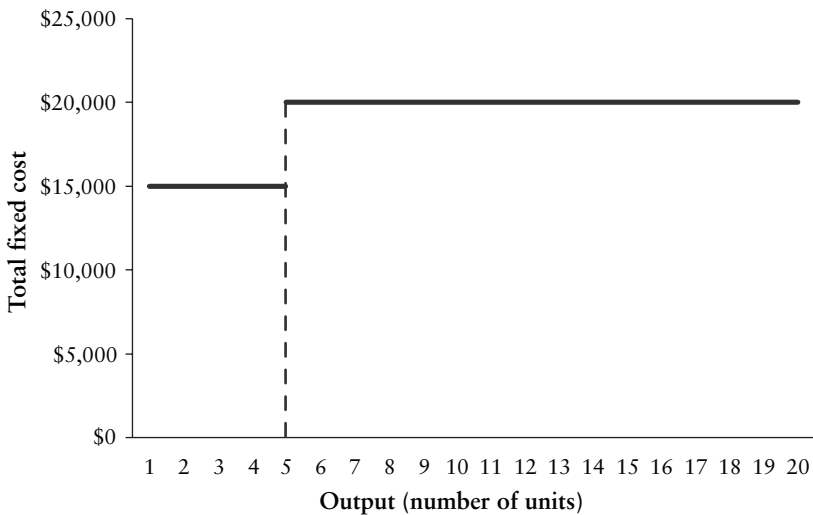
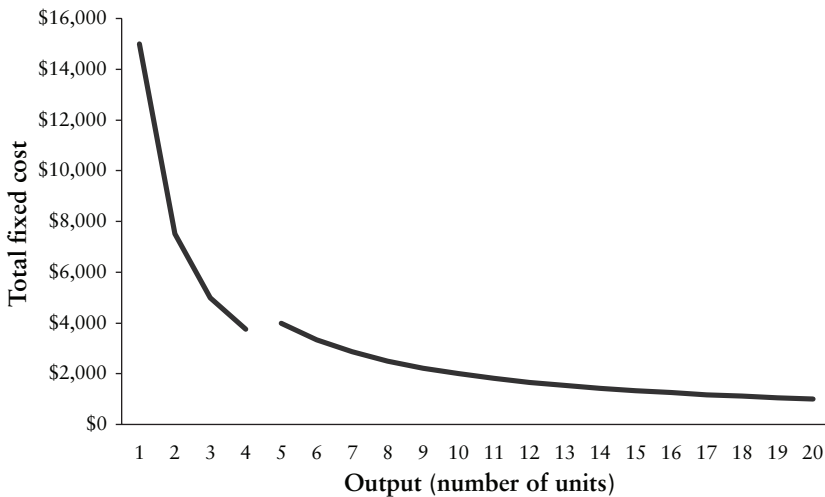

FIGURE 19.5 Pattern of Fixed Costs per Unit

productive capacity, which will be examined in Chapter 24, where we discuss standard cost.

There exists a potential misuse of unitized fixed cost. The fact that fixed cost per unit changes as production changes does not mean that fixed cost should be treated like variable costs. Increasing production volume (within the relevant range) will decrease fixed cost per unit, but total fixed costs will not change. For example, assume that at the beginning of year 1, a \$40,000 computer was purchased to service Departments C and D. The computer was expected to last four years with no salvage value and was to be depreciated using the straight-line method. It was projected that 10,000 total computer hours would be used in year 1 with Department C requiring 6,000 hours and Department D requiring 4,000 hours. The $\$40,000/4 \text{ years} = \$10,000$ annual depreciation was to be allocated to each department on the basis of computer hours used. The cost per computer hour in year 1 was \$1.00, computed as follows:

$$\$10,000 = \$1.00 \text{ per hour for each of 10,000 hours}$$

During year 1 the following computer hours were used:

| | |
|--------------|-------------|
| Department C | 6,000 hours |
| Department D | 4,000 hours |

The computer depreciation costs allocated to Departments C and D were computed as follows:

| | |
|-------------------------------------|--------------|
| Department C (6,000 hours × \$1.00) | \$6,000 |
| Department D (4,000 hours × \$1.00) | <u>4,000</u> |
| Total depreciation allocated | \$10,000 |

This method of handling the allocation of the fixed depreciation costs of the computer appears to be sound. However, consider year 2. During year 2 the following computer hours were used:

| | |
|--------------|-------------|
| Department C | 6,000 hours |
| Department D | 2,000 hours |

The manager of Department C used the computer for the same amount of hours as in year 1 and therefore expects that \$6,000 will again be allocated to Department C. Instead, Department C is charged with \$7,500. Department C used the same number of hours with no change in costs and yet \$1,500 more was allocated to it. This ludicrous situation resulted because a fixed cost (i.e., depreciation) was improperly allocated as if it were a variable cost. Department C was allocated \$7,500 because the total computer hours used in year 2 were only 8,000 (6,000 hours for Department C plus 2,000 hours for Department D). The cost per computer hour in year 2 was \$1.25, computed as follows:

$$\$10,000 = \$1.25 \text{ per hour} \times 8,000 \text{ hours}$$

This avoidable error is, unfortunately, all too common in practice. Managers must understand fixed cost behavior from a total and per-unit viewpoint so as not to misuse fixed costs, especially in decision making. Continuing our computer cost allocation problem, the annual fixed cost of depreciation should have been allocated using a fixed percentage based on the projected long-run average use by each department. For example, if it was projected that Department C would use the computer 75% of the time and Department D 25% of the time, then the fixed costs should be allocated 75% to Department C (\$7,500 each year) and 25% to Department B (\$2,500 each year) regardless of actual use. If Department D used the computer less than planned, it still should be charged with 25% of the cost because the “capacity” of the computer originally acquired was based on each department’s projected long-run average needs; therefore Department D should be made to bear, in this situation, the full cost of the underutilized computer capacity.

In summary, we have observed the following about the relationship between cost and volume within the relevant range:

- Total variable costs change in proportion to changes in volume.
- Per-unit variable costs remain constant when volume changes.
- Total fixed costs remain constant when volume changes.
- Per-unit fixed costs increase (decrease) when volume decreases (increases).

Mixed Costs

Mixed costs contain both fixed and variable characteristics over various relevant ranges of operation. Two types of mixed costs exist: semivariable costs and step costs.

Semivariable Cost

Semivariable costs contain both fixed and variable costs. The fixed part of a semivariable cost usually represents a minimum fee for making a particular item or service available. The variable portion is the cost charges for actually using the service. For example, most telephone service charges are made up of two elements: a fixed charge for being allowed to receive or make a phone call, plus an additional or variable charge for each phone call made. Telephone charges are relatively simple to separate into fixed and variable costs; however, in some situations, the variable and fixed components must be approximated.

Assume that a company rents a delivery truck at a flat fee of \$2,000 per year plus \$0.15 for each mile driven. The fixed component is the \$2,000 annual rental fee; the variable component is the \$0.15 for each mile driven. If 10,000 miles are driven during the year, the total annual cost of the delivery truck is \$3,500, computed as follows:

| | |
|---|--------------|
| Flat fee (fixed component) | \$2,000 |
| Mileage charge (variable component) (10,000 miles × \$0.15) | <u>1,500</u> |
| Total cost | \$3,500 |

We demonstrate semivariable costs in Figure 19.6. The vertical axis in this figure represents total costs and the horizontal axis represents mileage. The fixed portion of \$2,000 is noted by a dashed horizontal line from the vertical axis. The variable portion of \$1,500, at the 10,000 mile level, is represented by the distance between \$3,500 and \$2,000.

Step Cost

The fixed part of step costs jumps abruptly at various activity levels because these costs are acquired in indivisible portions. An example of a step cost

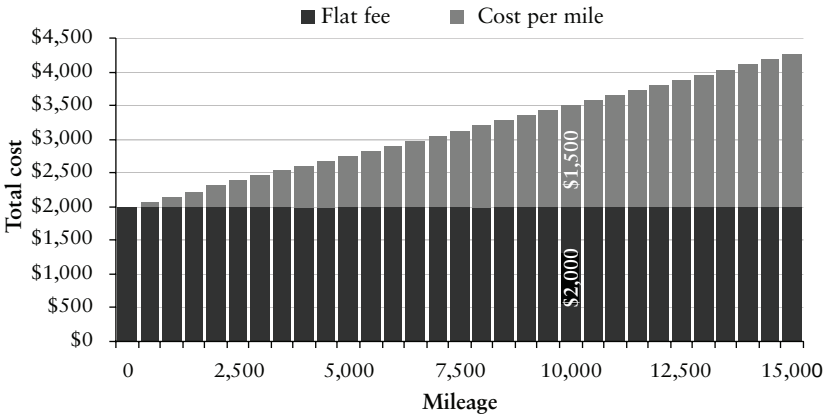
FIGURE 19.6 Semivariable Costs

is the salary of supervisors. If one supervisor is needed for every 10 workers, then two supervisors would be required if, for example, 15 workers are used. If an additional worker is hired (increasing the number of workers to 16), still only two supervisors would be needed. However, if the number of workers increases to 21, three supervisors would be needed. A step cost is similar to a fixed cost within a very small relevant range.

We illustrate step costs graphically in Figure 19.7. Assume that supervisors are paid \$30,000 a year and one supervisor is needed for every 10 workers. In Figure 19.7, the vertical axis represents total costs and the horizontal axis represents the number of workers. The solid lines represent various total costs for supervisors at different levels of workers. The resulting horizontal lines give the appearance of a series of steps and hence the name for this type of cost.

In Table 19.3, we provide some examples of variable, fixed, semivariable, and step costs. Although mixed costs are neither wholly fixed nor wholly variable in nature, they must ultimately be separated into their fixed and variable components for purposes of planning and control. When a relationship is found to exist between two variables, statistical techniques are available to divide a mixed cost into its fixed and variable components.

ABILITY TO TRACE

A cost may be considered direct or indirect depending on management's ability to trace it to specific jobs, departments, sales territories, and so forth. *Direct costs* are costs that management is capable of tracing to specific items

FIGURE 19.7 Step Costs

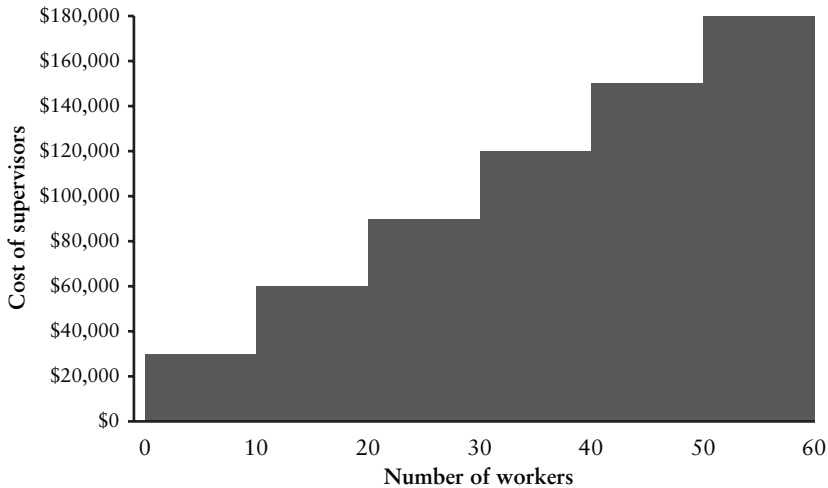

TABLE 19.3 Factory Costs

| Variable Costs | Fixed Costs | Mixed Costs | |
|---|---|--------------------|---------------------|
| | | Semivariable Costs | Step Costs |
| Direct materials | Building maintenance | Truck rentals | Supervisor salaries |
| Direct labor (piece rate) | Depreciation (except for units of production) | Equipment rentals | Inspection |
| Electricity for machinery | Plant taxes | Utilities | |
| Depreciation under units of production method | Plant insurance | Telephone service | |
| | Warehouse rent | | |

or areas. Examples of direct costs are direct materials and direct labor costs for a specific product. Indirect costs are costs that are common to many items and are therefore not directly traceable to any one item or area. *Indirect costs* are usually charged to items or areas on the basis of allocation techniques. For example, indirect manufacturing costs are allocated to products after first being accumulated in a factory overhead cost pool.

DEPARTMENT WHERE INCURRED

A department is a major functional division of a business. Costing by departments helps management to control overhead costs and to measure income. The following types of departments are found in manufacturing companies:

- *Production departments.* These contribute directly to the production of the item and include departments in which conversion or production processes take place. They include manual and machine operations directly performed on the product manufactured.
- *Service departments.* These are departments that are not directly related to the production of an item. Their function is to provide services for other departments. Examples of service departments are payroll, factory office personnel, cafeteria, and plant security. The costs of service departments are usually allocated to production departments since they benefit from the services provided.

For example, Company One has only one production department and all the machinery in that department is kept in operating condition by the maintenance department. The maintenance department is also required to provide janitorial and maintenance services to the rest of the company. Therefore, a portion of the maintenance department's cost should be allocated to the production department and will become part of product cost. The portion not allocated to the production department may be allocated to another service department or to a nonplant department, such as the sales department, and will be an expense of that department for the current period.

The basis for allocating service department costs usually varies according to the service provided. For example, two common bases for allocating service department costs are square feet serviced for a building and grounds service department and number of employees for a personnel service department.

FUNCTIONAL AREAS

Costs classified by function are accumulated according to activity performed. All costs of a manufacturing organization may be divided into manufacturing, marketing, administrative, and financing, defined as follows:

- *Manufacturing costs* are related to the production of an item. They are the sum of direct materials, direct labor, and factory overhead costs.
- *Marketing costs* are costs incurred in promoting a product or service.
- *Administrative costs* are cost incurred in directing, controlling, and operating a company and include salaries paid to management and staff.
- *Financing costs* are costs related to obtaining funds for the operation of the company. They include the cost of interest that the company must pay on loans, as well as the cost of providing credit to customers.

TABLE 19.4 Analysis by Function

| | Year 1 | Year 2 | Total Change |
|-----------------------|---------------|--------------|---------------|
| Manufacturing costs | \$250,000 | \$335,000 | +\$85,000 |
| Marketing costs | 90,000 | 90,000 | 0 |
| Administrative costs | 50,000 | 70,000 | +20,000 |
| Financing costs | <u>10,000</u> | <u>5,000</u> | <u>-5,000</u> |
| Total operating costs | \$400,000 | \$500,000 | +\$100,000 |

If the CFO wants to analyze the current period's operations, one method would be to classify costs by functions and compare them to parallel costs for a previous year. Knowing that a company had \$400,000 total operating costs for year 1 and \$500,000 total operating costs for year 2 would not provide sufficient information for the CFO to determine the cause(s) of the increase. A further detailed analysis by functions would be necessary in order to explain why total costs increased by \$100,000. Assume that revenue was the same for both years. We provide an example of this type of analysis by function in Table 19.4.

This analysis reveals that the increase in total operating costs resulted from manufacturing and administrative functions. These functions should be examined by the CFO to determine if the increases were appropriate. The decrease in financing costs should also be analyzed to determine its cause, especially when the decrease was totally unexpected and the amount was significant.

PERIOD CHARGE IN INCOME

Costs may also be classified on the basis of when they are to be charged against revenue. Some costs are first recorded as assets (for example, capital expenditures) and then expensed (that is, charged as an expense) as they are used or expire. Other costs are initially recorded as expenses. The classification of costs into categories relating to the periods they benefit aids in measuring income, in preparing financial statements, and in matching expenses to revenue in the proper period. Two categories used are product costs and period costs.

Product costs are costs directly and indirectly identifiable with the product. They are direct materials, direct labor, and factory overhead. These costs provide no benefit until the product is sold and are, therefore, inventoried upon completion of the product. When the products are sold, the total product costs are recorded as an expense, called the cost of goods sold. Cost of goods sold is matched against revenue for the period in which the products are sold.

Period costs are costs that are neither directly nor indirectly related to the product and these are not inventoried. Period costs are charged off immediately because no relationship between cost and revenue can be determined. The following are examples of period costs: salary of the accounting department (administrative expense), depreciation on company-owned cars used by the sales personnel (marketing expense), and interest incurred on corporate bonds (financing expense).

Figure 19.8 charts the relationship between product and period costs.

RELATIONSHIP TO PLANNING, CONTROLLING, AND DECISION MAKING

Costs that aid management in its planning, controlling, and decision-making functions are briefly defined as follows and explained further in later chapters. The classification of costs into various categories as we have done below is not to be construed as definitive. That is, the boundaries that separate the categories are not very clear cut. In Figure 19.9 we present an overview of the cost accounting information pool.

Standard and Budgeted Costs

Standard costs are those that should be incurred in a particular production process under normal conditions. Standard costing is usually concerned with per-unit costs for direct materials, direct labor, and factory overhead; it serves the same purpose as a budget. (A budget is a quantitative expres-

FIGURE 19.8 Product and Period Costs

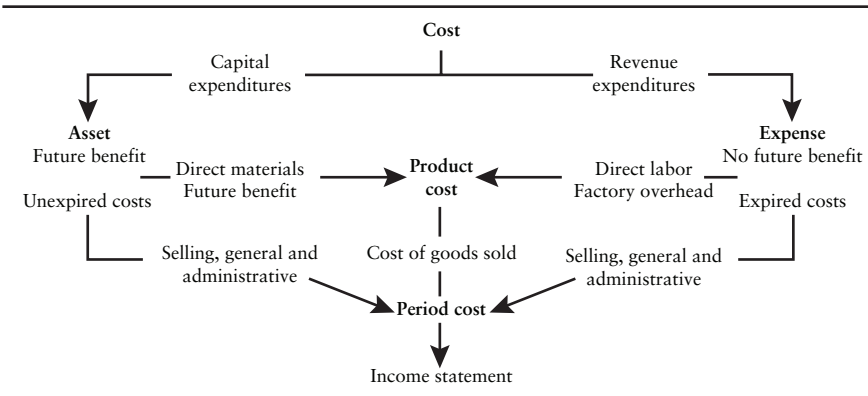

FIGURE 19.9 Accounting Information Pool

sion of management objectives and a means of monitoring progress toward achievement of those objectives.) Budgets, however, usually provide forecasted activity on a total cost basis rather than on a unit cost basis. Standard costs and budgets are used by management first to plan upcoming performance and second to control actual performance through variance analysis (i.e., the difference between expected and actual amounts).

Controllable and Noncontrollable Costs

Controllable costs are those that may be directly influenced by unit managers in a given time period. For example, where managers have the authority of acquisition and use, the cost may be considered to be controllable by them. Noncontrollable costs are those costs that are not directly administered at a given level of management authority.

Committed and Discretionary Fixed Costs

A *committed fixed cost* arises, of necessity, from having a basic organizational structure (i.e., essential property, plant, equipment, salaried personnel, etc.). It is a long-run phenomenon that usually cannot be adjusted downward without adversely affecting the ability of the organization to operate at even a minimum level of productive capacity.

A *discretionary fixed cost* arises from yearly appropriation decisions for repairs and maintenance costs, advertising costs, executive training, and so on. It is a short-run phenomenon that usually can be adjusted downward, thereby permitting the organization to operate at any desired level of productive capacity provided for by the committed fixed costs.

Relevant and Irrelevant Costs

Relevant costs are expected future costs that differ among alternative courses of action and may be eliminated if some economic activity is changed or deleted. *Irrelevant costs* are unaffected by management's actions. *Sunk costs* are an example of irrelevant costs. Sunk costs are past costs that are now irrevocable, such as depreciation on machinery. When confronted with a choice, they are not relevant and should not be considered in a decision-making analysis, except for possible tax effects upon their disposition and painful lessons to be learned from past mistakes.

Relevancy is not an attribute of a particular cost; the identical cost may be relevant in one circumstance and irrelevant in another. The specific facts of a given situation will dictate which costs are relevant and which are irrelevant.

Differential Costs

A *differential cost* is the difference between the costs of alternative courses of action on an item-by-item basis. If the cost is increasing from one alternative to another, it is called an *incremental cost*; if the cost is decreasing from one alternative to another, it is called a *decremental cost*.

When analyzing a specific decision, the key is the differential effects of each option on the company's profits. Frequently, variable costs and incremental costs are the same. However, should a special order, for example, extend production beyond the relevant range, both variable and total fixed costs would increase. In that event, the differential in fixed costs should be included in the decision-making analysis along with the differential in variable costs.

Opportunity Costs

Where a decision to pursue one alternative is made, the benefits of other options are forgone. Benefits lost from rejecting the next best alternative are the *opportunity costs* of the chosen action. Since opportunity costs are not actually incurred, they are not recorded in the accounting records. They are, however, relevant costs for decision-making purposes and must be considered in evaluating a proposed alternative.

Shutdown Costs

Shutdown costs are those fixed costs that would be incurred even if there were no production. In a seasonal business, management is often faced with decisions of whether to suspend operations or remain open during the off-season. In the short run, it is advantageous for the firm to remain open as long as sufficient sales revenue can be generated to cover variable costs and contribute to the recovery of fixed costs. Typical shutdown costs that must be considered when deciding whether to close or stay open are rent, severance pay for employees, storage costs, insurance, and salaries for the security staff.

TECHNIQUES FOR NEW PRODUCT COST ESTIMATION

In later chapters, we will explain techniques used by accountants for product costing. Today, a critical task performed by the managerial accounting staff is providing accurate cost estimates quickly to managers that can be used for providing quotations at the early stage of product development. The importance of this task today cannot be overemphasized as product life cycles for many products are short lived, making it essential that managers have the right information to decide whether to enter new product markets.

The product cost estimate must then be linked to the cost of monitoring of a new product. Once the cost per unit of a new product is estimated, an estimate of the investment that will have to be made in the new product must be determined. The amount of investment in inventory is related to the amount of time from manufacturing to proceeds received from the customer. This investment in inventory is referred to as the *pipeline investment*. Again, given shorter product life cycles, the implication is that there is a shorter time to recover the pipeline investment for a new product.

Basics of Cost Estimation

In estimating the cost of a new product in early development, the group or staff responsible for estimating cost, typically a staff comprised of engineers and economists, will have access to the cost of creating one or more prototypes of the new product. However, this information is often not very helpful. This is because prototypes are expensive to produce and typically cannot be relied upon. For example, at Ford Motor Company, the cost of building a prototype typically exceeds \$250,000. For some complex vehicle programs, Ford will find it necessary to build from 100 to 200 full-vehicle prototypes.¹ There are three major reasons for the differences between the cost of a prototype and the cost in normal production.²

The first reason is that the company may use custom components in creating the prototype. When a product is ultimately produced using the normal production process, the cost of the component parts previously customized will decline, often dramatically. The second reason is that even with standard components acquired to build a prototype, the price of those components will be greater than they would be when the standard components are purchased in volume during normal production. Hence, when estimating product costs in early development of a new product, it is essential that the management distinguish between prototype component costs and the costs in normal production. Failure to do so will result in turning away the manufacturing of potentially profitable products. The third reason is that there is a learning in production. As employees become more familiar with the production process, there may be some efficiency gains.

Cost Estimation Techniques

There are several techniques used to estimate new product costs by accountants and engineers. In this section, we will identify these techniques. Ni-azi, Dai, Balabani, and Seneviratne provide a hierarchical classification of production cost estimation techniques.³ The classification begins with what they refer to as qualitative techniques and quantitative techniques. The discussion below is based on their hierarchical classification.

Techniques that seek to estimate the cost of a new product based on a comparison to the cost of products previously manufactured are classified as

¹ “Optimizing Prototype Vehicle Testing at Ford Motor Company,” http://www.scienceofbetter.org/can_do/success_stories/opvtfmc.htm.

² “Estimating Product Costs During Development,” an Arena Solutions whitepaper, www.arenasolutions.com.

³ Adnan Niazi, Jian S. Dai, Stavroula Balabani, and Lakmal Seneviratne, “Product Cost Estimation: Technique Classification and Methodology Review,” *Journal of Manufacturing Science and Engineering* (May 2006), pp. 563–575.

qualitative techniques. By identifying the similarities between a new product and previously manufactured products, historical costs of producing these products can be used as a good rough cost estimate assuming that the design is similar and past data continues to be reliable. Qualitative techniques are further classified as *intuitive* and *analogical* techniques.

Niazi, et al. state for intuitive cost estimation techniques:

A domain expert's knowledge is systematically used to generate cost estimates for parts and assemblies. The knowledge may be stored in the form of rules, decision trees, judgments, etc., at a specific location, e.g., a database to help the end user improve the decision-making process and prepare cost estimates for new products based on certain input information.⁴

There are two methodologies that fall into the category of intuitive cost estimation techniques: case-based methodology and data support systems.⁵

Analogical cost estimation techniques according to Niazi, et al. employ similarity criteria based on historical cost data for products with known cost. These techniques include regression analysis models and back-propagation neural-network methods. The regression analysis requires examining historical relations among the input costs and other elements of production. A *neural network* in this context is a system of relationships or functions, among the different drivers or factors in the production system, with various connections and interconnections between these functions. A neural network may be adaptive, such that learning takes place: experience will influence the connections. Both regression and neural networks techniques are what accountants would classify as *quantitative* techniques because they are statistical methodologies. However, because they are based on historical cost data for estimating the cost of a new product, they are referred to as a type of qualitative technique.⁶

Rather than relying on past data, quantitative techniques are based on a detailed analysis of the design of a product, the features of a product, and the processes used in manufacturing the product. An analytical function

⁴ Niazi et al., "Product Cost Estimation: Technique Classification and Methodology Review," p. 564.

⁵ These techniques are described in Niazi et al., "Product Cost Estimation: Technique Classification and Methodology Review."

⁶ See M. S. Hundal, "Design to Cost," in H. R. Parsaei and W. G. Sullivan (eds.), *Concurrent Engineering: Contemporary Issues and Modern Design Tools* (London: Chapman and Hall, 1993), pp. 330–351; C. Poli, J. Escudero, and R. Fernandez, "How Part Design Affects Injection-Molding Tool Costs," *Machine Design*, 60 (1988), pp. 101–104; G. Pahl and W. Beitz, *Engineering Design: A Systematic Approach*, 2nd ed. (Berliner: Springer-Verlag, 1996).

is then estimated that relates the resources utilized and the cost of those resources. By summing the costs of all the resources, the cost of the product is estimated. Quantitative techniques are further classified as *parametric* and *analytical* techniques.

Parametric cost estimation techniques apply statistical methodologies to derive a cost function, typically on a per-unit basis.⁷ The variables in the statistical analysis are the cost drivers. An example is the parametric model to estimate the unit cost to manufacture a new brake disk by an Italian manufacturing firm developed by Cavaleri, Maccarrone, and Pinto.⁸ The parametric model they developed, referred to as the Cost Estimation Relationship (CER) is:

$$C = FC + \left(C_{co} N_{co} + \frac{C_{rm} TF}{1 - SC} \right) W$$

where

- C = cost per unit of the new disk brake
- FC = fixed cost factor
- C_{co} = core cost per kilogram of cast iron
- N_{co} = number of cores
- C_{rm} = unit cost of raw material
- TF = cast-iron steel conversion factor
- SC = scrap or waste factor
- W = weight of the raw disk

The three cost drivers in the parametric model are W, N_{co}, and C_{rm}. Using regression analysis, the relation between each of these drivers and product cost would be estimated. The coefficients estimated in the model are FC, SC, and TF, which are adjustments that consider the different production systems that a company may use.

Analytical cost estimation techniques involve decomposing the manufacturing of a product into elementary units, operations, and activities of the resources used during the production cycle. The cost of the product is then the sum of the resources used. The techniques that fall into this category are:

⁷ For references to studies using parametric models, see Niazi et al., “Product Cost Estimation: Technique Classification and Methodology Review.”

⁸ Sergio Cavaleri, Paolo Maccarrone, and Roberto Pinto, “Parametric vs. Neural Network Models for the Estimation of Production Costs: A Case Study in the Automotive Industry,” *International Journal of Production Economics* 91, no. 2 (2004), pp. 165–177.

- Operations-based approach
- Breakdown approach
- Tolerance-based cost models
- Feature-based cost approach
- Activity-based costing system

The last approach, referred to as the *ABC system*, is explained in a later chapter.⁹

BOTTOM LINE

- Cost is defined as the value given up to acquire goods or services.
- In order to provide data that is relevant to management for product pricing, performance evaluation, and other decisions, costs can be classified in the following manner: elements of a product, relationship to production, relationship to volume, ability to trace, department where incurred, functional areas, period charged to income, and relation to planning, controlling, and decision making.
- Elements of a product include material, labor, and factory overhead.
- When costs are classified according to their relationship, they are classified as prime costs and conversion costs.
- In terms of costs in relationship to volume, costs are classified as variable costs, fixed costs, and mixed costs.
- A cost may be considered direct or indirect depending on management's ability to trace it to specific jobs, departments, sales territories, and so on.
- Costs can be classified by department (production departments and service departments) and functional areas (manufacturing costs, marketing costs, administrative costs, and financing costs).
- Costs classified on the basis of when they are to be charged against revenue are broken down into product costs and period costs.
- Costs that aid management in its planning, controlling, and decision-making functions are classified as standard and budgeting costs, controllable and noncontrollable costs, committed and discretionary fixed costs, relevant and irrelevant costs, differential costs, opportunity costs, and shutdown costs.
- There are several techniques for estimating the cost of a new product. These techniques are classified as qualitative techniques and quantitative techniques.

⁹ For a discussion of the other techniques see the following and the references therein, see Niazi et al., "Product Cost Estimation: Technique Classification and Methodology Review."

Costing and Control of Materials, Labor, and Factory Overhead

AGENDA

- Item 1* Distinguish between and account for direct and indirect materials and labor as they are used in the production process.
- Item 2* Differentiate among the forms used in the purchase and issuance of materials such as a purchase requisition, a purchase order, a receiving report, and a materials requisition.
- Item 3* Compare and contrast the periodic and perpetual cost accumulation systems used to account for materials issued to production and for ending materials inventory.
- Item 4* List and describe briefly the five common control procedures used to assist management in keeping inventory costs to a minimum and plant production flowing.
- Item 5* Identify the three activities involved in accounting for labor.
- Item 6* Describe the accounting for employee and employer taxes and fringe benefit costs.
- Item 7* Identify the guaranteed wage and incentive plans that may be used.
- Item 8* Apply the concept of factory overhead as an accumulation of all indirect manufacturing costs.
- Item 9* Compute a factory overhead application rate using the appropriate denominator activity.
- Item 10* Explain the four estimated levels of production and discuss their importance in calculating an appropriate factory overhead application rate.
- Item 11* Apply the concepts of applied factory overhead, actual factory overhead, and under- and overapplied factory overhead and illustrate how these accounts are utilized in the journalization of factory overhead.

Manufacturing is the process by which raw materials are converted into a finished product. Raw materials normally constitute a major cost element of production. After raw materials are purchased and temporarily

placed in a storeroom, a manufacturer proceeds to transform them into finished products via the incurrence of conversion costs (direct labor and factory overhead). If the manufacturing process is labor intensive, labor costs will constitute a very significant element in the conversion process. Highly automated production processes that take advantage of robotics and high-tech manufacturing equipment may find that factory overhead is a major component of the cost of producing a product. In this chapter we explore the costing and control of materials, labor, and factory overhead.

MATERIALS (STORES)

Materials or stores are the basic ingredients that are transformed into finished goods through the use of labor and factory overhead in the production process. Material costs can be either direct or indirect.

Direct materials are those that can be identified with the production of a finished product, that can be easily traced to the product, and that represent a major cost of the finished product. An example would be the steel used to build a car. Direct materials, along with direct labor, are classified as *prime costs*.

Indirect materials comprise all the other materials or supplies involved in the production of a product that are not classified as direct materials. Examples are glue used in the manufacture of furniture and rivets used to assemble a car (that is, necessary but relatively insignificant costs). Indirect materials are considered factory overhead costs.

Accounting for Materials

Accounting for materials by a manufacturer usually involves two activities: the purchase of materials and their issuance.

Purchase of Materials

Most manufacturers have a purchasing department whose function is to order raw materials and supplies needed for production. The manager of the purchasing department is responsible for assuring that the items ordered meet the quality standards set by the company, are acquired at the lowest price, and are delivered on a timely basis. Three forms are commonly used in purchasing goods: a purchase requisition, a purchase order, and a receiving report.

Purchase Requisition A purchase requisition is a written request, usually sent to inform the purchasing department of a need for materials or sup-

plies. The clerk would fill out a purchase requisition form and send it to the purchasing department so that they can place the order.

Although a purchase requisition is usually preprinted according to the specifications of a particular company, most forms include the requisition (serially numbered), name of department or individual making the request, quantity of items requested, identifying catalog number, description of the item, unit price, total price, shipping, handling, insurance and related costs, total cost of entire requisition, order date, required delivery date, and authorized signature.

Purchase Order If the purchase requisition is properly completed, the purchasing department issues a purchase order. A purchase order is a written request to a supplier for specified goods at an agreed-upon price. The request also stipulates terms of delivery and terms of payment. The purchase order is the supplier's authorization to deliver goods and submit a bill. All items purchased by a company should be accompanied by purchase orders, which are serially numbered to provide control over their issuance. The following items are commonly included in a purchase order: preprinted name and address of company placing the order, purchase order number, name and address of supplier, order date, date delivery is requested, delivery and payment terms, quantity of items ordered, catalog number, description, unit and total price, shipping, handling, insurance and related costs, total cost of entire order, and authorized signature.

Receiving Report When the goods that were ordered are delivered, the receiving department unpacks and counts them. (It is interesting to note that the quantity ordered is not shown on the copy of the purchase order sent to the receiving department. This deliberate omission ensures that the goods delivered are actually counted.) The goods are checked to be sure that they are not damaged and that they meet the specifications of the purchase order and the packing slip (a list, prepared by the supplier, that accompanies the order and details what is in the shipment). Next, the receiving department issues a receiving report. This form includes the supplier's name, purchase order number, date delivery was received, quantity received, description of goods, discrepancies from the purchase order (or mention of damaged goods), and authorized signature.

Figure 20.1 illustrates the use of these forms. The vendor's invoice (supplier's bill) is included because the cycle is not complete until the proper amount as per the invoice, less any discount, is paid. For purposes of internal control, the three documents—purchase order, receiving report, and vendor's invoice—should be matched and approved by an independent party. Otherwise, for example, the purchasing agent who placed the order

FIGURE 20.1 Purchase Requisition, Purchase Order, Receiving Report, and Vendor's Invoice

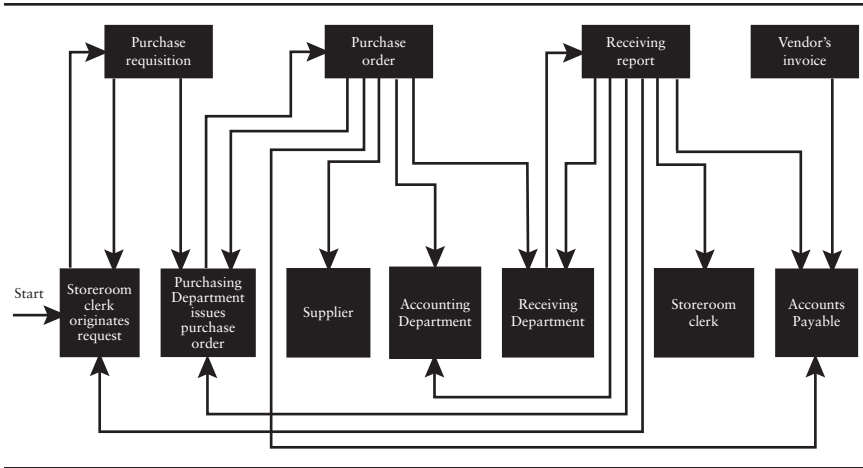

could approve the invoice at a higher price than the purchase order and perhaps receive a kickback from the supplier. It would be best for people in an unrelated section of the accounting department to be responsible for checking and approving since they would not have a conflict of interest.

Issuance of Materials

The person in charge of the storeroom is responsible for the proper storage, protection, and issuance of all materials placed in his or her custody. The issuance must be authorized by means of a materials requisition form prepared by the production manager or department supervisor. Each materials requisition form shows the job number or department requesting the goods, their quantity and description, and the unit cost and total cost of the goods issued.

The cost that is entered on the materials requisition form is the amount charged to production for materials consumed. Computing the total cost of materials issued seems relatively simple: The unit cost of an item is multiplied by the quantity purchased. The quantity is readily determined from the materials requisition form; however, determining the unit cost of materials issued is not that simple during periods of inflation (rising prices) or deflation (declining prices).

During a period of changing prices, what price should be used for materials placed into production during the period and what price should be used for the materials still on hand at the end of a period (ending materials inventory)? Should the cost of materials issued be multiplied by the begin-

ning unit price of materials, the average unit price for the period, or the ending unit price?

Systems of Accounting for Materials Issued to Production and Ending Materials Inventory

Either the periodic inventory system or the perpetual inventory system may be used to account for materials issued in production and ending materials inventory.

Accounting by the Periodic Inventory System Under a *periodic inventory system*, the purchase of materials is recorded in an account entitled “Purchases of Raw Materials.” If a beginning materials inventory exists, it is recorded in a separate account entitled “Materials Inventory Beginning.” Purchases plus beginning inventory equal materials available for use during a period. To arrive at the ending materials inventory, a physical count must be made of the materials still on hand at the end of the period. The cost of materials for the period is determined by subtracting the ending materials inventory from the materials available for use during the period. The cost of materials is therefore determined from the following relationship:

$$\text{Beginning inventory} + \text{Purchases} = \text{Cost of materials} + \text{Ending inventory}$$

Note that under this method the cost of materials issued is not directly determined; it is indirectly computed as a residual. In other words, the cost of materials issued equals what is left over after the cost of the ending inventory is subtracted from the cost of the materials available for use.

Accounting by the Perpetual Inventory System Under the perpetual inventory system, the purchase of materials is recorded in an account labeled “Materials Inventory,” rather than in a purchase account. If beginning materials inventory exists, it would also be recorded as a debit in the Materials Inventory account. When materials are issued, the Materials Inventory account is credited for the cost of materials issued with a corresponding debit to the work-in-process inventory account. The end result is that the cost of materials issued is charged to production at the time when the materials are issued, and the balance in the Materials Inventory account shows the cost of materials still available for use. Thus, under the perpetual inventory method, both the cost of materials issued and the ending materials inventory can be directly ascertained after each transaction.

Subsidiary ledger records must be maintained when a perpetual inventory system is used to account for materials inventory. The total of the mate-

materials subsidiary ledger must equal the amount in the Materials Inventory Control account in the general ledger. The materials subsidiary ledger has a separate inventory record for each type of item in inventory. The typical form of an inventory record shows the date, quantity, and dollar amount of materials received (debit) and issued (credit), and the resulting balance (debit). The use of the perpetual inventory method also requires the taking of a physical count of materials on hand at least once a year in order to check for possible error or shrinkage due to theft or spoilage. If a physical count disagrees with the balances in the inventory record cards, the book figures are adjusted upward or downward to reflect the actual count.

Control Procedures

It is of utmost importance that a company have a good system of materials inventory control. Achievement of good control keeps costs at a minimum level and plant production on a smooth, uninterrupted schedule. The following principles should be incorporated into an inventory-control system:

- Inventory is the result of purchasing raw materials and parts. It is also the result of applying labor and factory overhead to the raw materials to produce finished goods.
- Reduction of inventory is the result of normal use and either finding alternative uses for or scrapping unneeded items.
- Optimum inventory investment is based on quantitative techniques that are designed to minimize the cost of carrying inventory and the cost of ordering inventory.
- Efficient purchasing, management, and investment in materials depend on an accurate forecast of sales and resulting production schedules.
- Forecasts help determine when to order materials. Controlling inventory is accomplished through production scheduling.
- Inventory control is more than maintaining inventory records. Control is exercised by people who are making personal judgments partially on the basis of their past experiences. Their decisions are made within a general framework of organizational objectives and policies to achieve them. Control is relative, not absolute.
- Methods of inventory control vary depending for the most part on the cost of the materials and their importance to the manufacturing process. Expensive materials, or those essential to production, tend to have their program for control reviewed more frequently despite the cost and effort of doing so by experienced personnel.

LABOR

Labor is the physical or mental effort expended in manufacturing a product. Labor cost is the price paid for using human resources. The compensation paid to employees who engage in production-related activities represents factory labor cost. Direct laborers are those who work on a product directly, either manually or by using machines. Direct labor is all labor that is directly involved in the production of a finished product, that can be easily traced to the product, and that represents a major labor cost of producing that product. Examples are assembly-line workers in an automobile factory or knitting machine operators in a sweater factory. Direct labor is considered both a prime cost and a conversion cost.

Indirect labor is factory labor not directly traceable to a product; also, it is not considered worthwhile to try to relate the cost of the indirect labor to production. Laborers whose services are indirectly related to production include product designers, job supervisors, and product inspectors. Indirect labor is considered part of factory overhead cost.

Costs Included in Labor

The principal labor cost is wages paid to production workers. *Wages* are payments made on an hourly, daily, or piecework basis. *Salaries* are fixed payments made regularly for managerial or clerical services. However, in practice, the terms “wages” and “salaries” are often incorrectly used interchangeably.

Total labor costs have been increasing rapidly in recent years, particularly in areas such as vacation and holiday pay, pensions, hospitalization, life insurance, and other fringe benefit costs. In some cases these supplementary costs represent nearly 30% of regular earnings.

Accounting for Labor

Accounting for labor by a manufacturer usually involves three activities: timekeeping, computation of total payroll, and allocation of payroll costs. These activities must be performed before the payroll is recorded in the accounting records.

Timekeeping

Most large-scale manufacturers have a separate timekeeping section within a personnel department whose function is to collect the hours worked by employees. Two source documents commonly used in timekeeping are the time card and the labor job ticket.

A *time card* (clock card) is inserted in a time clock by the employee several times each day: upon arrival, going to lunch, taking a break, and when leaving for the day. By mechanically keeping a record of total hours worked *each* day by employees, this procedure provides a reliable source for computing and recording total payroll costs.

Labor job tickets are prepared daily by employees for each job worked on. Labor job tickets indicate the number of hours worked, a description of the work performed, and the employee's wage rate (inserted by the payroll department). The sum of the labor cost and hours for different jobs (as shown on labor job tickets) should be equal to the total labor cost and labor hours for the period (as shown on time cards).

Computation of Total Payroll

The payroll department's primary function is to compute the total payroll, including gross amount earned and the net amount payable to employees after deductions (for federal and state withholding taxes, Social Security taxes, and so on). The payroll department distributes the payroll and maintains records of employees' earnings, wage rate, and job classification.

Allocation of Payroll Costs

Using time cards and labor job tickets as a guide, the cost accounting department must allocate the total payroll costs (including the employer's portion of taxes and fringe costs) to individual jobs, departments, or products. Some companies have the payroll department prepare the allocation and send it to the cost accounting department where the appropriate journal entries are prepared. The total payroll cost for any one period must equal the sum of the labor costs allocated to the individual jobs, departments, or products. Figure 20.2 depicts the cycle for labor costs.

Special Problems Relating to the Accounting for Labor

The accounting for labor involves special problems that are not encountered in the accounting for materials. We discuss the following problem areas: employee taxes, employer taxes and fringe benefit costs, shift premiums, overtime, idle time, and minimum guaranteed wage and incentive plans.

Employee Taxes

Employers are required by law to withhold, from their employees' earnings, federal, state, and local income taxes (hereafter referred to collectively as

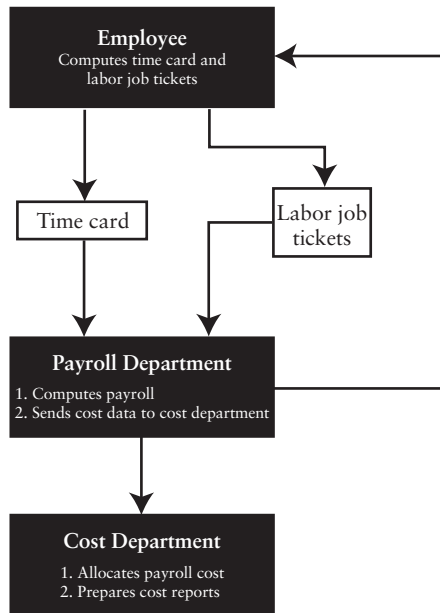
FIGURE 20.2 Cycle for Labor Costs

income taxes) and Social Security taxes as per the Federal Insurance Contributions Act (FICA). FICA taxes are designed to offer employees some measure of income upon retirement. Employers remit to the government, on a quarterly basis or more frequently, the employees' income taxes and FICA taxes withheld as well as the employers' share of payroll taxes.

Employer Taxes and Fringe Benefit Costs

Total payroll costs generally exceed the cost of gross wages or salaries by over 30%. Employers are required at present to match the employee's contribution to Social Security (FICA) and also to pay federal unemployment taxes [according to the Federal Unemployment Tax Act (FUTA)] and state unemployment insurance, herein referred to as SUI. The FUTA/SUI tax is levied only on employers up to a maximum limit on total gross earnings of employees subject to tax. The purpose of FUTA/SUI is to provide funds that can be used to pay unemployment benefits to employees in the event of terminated employment.

Most states also require that employers bear the cost of workers' compensation insurance (to provide funds to employees who are injured on the job).

The preceding payroll taxes must be paid by the employer. Two optional fringe benefits are contributions to health, life, or other insurance, and contributions to a guaranteed annual wage fund. Today, because of the skyrocketing costs of medical insurance, it is common to have the cost of health care paid jointly by the employer and employee.

Factory employees are generally entitled to paid vacations after an initial period of employment. The amount of vacation time is usually based on length of employment. For example, an employee who has worked between 1 and 5 years may get 2 weeks vacation, while an employee who has worked more than 5 years may be entitled to 3 weeks.

Vacation pay should not be charged to work-in-process when an employee is on vacation. An employee is contributing to production only while on the job. Therefore, only payroll costs for the weeks actually worked should be included in work-in-process inventory, and vacation pay should be accrued over that same period of productive labor and charged to factory overhead control. For holiday pay, the amount of the accrual depends on provisions of the labor contract or on company personnel policies, with the number of paid holidays usually ranging from 8 to 11 during a year. Accounting for holiday pay is handled much the same as vacation pay; in fact, many companies combine the two costs into one account, Vacation and Holiday Pay, making one entry instead of two.

In an actual business these accruals are generally based on estimated annual totals. Thus, the estimated total vacation pay could be based on last year's amount adjusted for any expected changes. Since most vacations are taken during July and August, any corrections in the accrual could be spread out over the last 5 or 6 months of the year so that no costs would be unduly distorted. This same accrual procedure can be used for other paid absences, such as jury duty or sick leave. For a salaried employee, the vacation pay, holiday pay, or other paid leave is charged to the period in which the absence occurs. It is assumed that the work will be done by another person during the absence or that the absent employee will take care of it upon returning. If a temporary worker is hired to handle the duties, the additional labor cost is charged to factory overhead control (to avoid double counting). Payroll fringe benefit costs have increased appreciably. A growing number of companies have chosen to treat fringe benefit costs as direct labor costs. However, most companies still include the cost of fringe benefits in factory overhead accounts.

Shift Premiums

It is an accepted practice to pay shift premiums, or higher hourly rates, for the less desirable evening shift (3 P.M. to 11 P.M.) or night shift (11 P.M. to

7 A.M.) This shift premium, or shift differential, should be charged to factory overhead control rather than work-in-process, and spread over all units produced.

Note that charging factory overhead control for shift premiums (instead of work-in-process) is especially important when a job order cost system is used because the unit cost of individual jobs produced when shift premiums are paid will not be distorted. Shift premiums are not caused by specific jobs and therefore should be spread over all the jobs produced during the period.

Overtime Premium

Regular earnings represent the total hours worked, including overtime hours, multiplied by the regular pay rate. Overtime premium represents the overtime hours multiplied by the premium rate. The premium rate for overtime is usually some fraction of the regular rate. Overtime is commonly referred to as time-and-a-half because most overtime hours worked are paid at the regular rate plus a premium of one-half the regular rate. Three accounting treatments that are commonly used are based on the underlying cause of overtime.

- *Treatment 1:* Most overtime results from the random scheduling of jobs and should be treated like a shift premium and charged to factory overhead control.
- *Treatment 2:* When overtime results from the requirements of a specific job and not from random scheduling, the overtime premium should be charged to the specific job that caused the overtime.
- *Treatment 3:* If overtime resulted from negligence or poor workmanship on the part of a worker, then the overtime premium should be charged as a loss.

The type of accounting treatment accorded overtime is important in that it determines what actions, if any, should be taken by management in the planning and control of labor costs. For example, the recording of a loss might call for closer supervision or better on-the-job training.

Idle Time

Idle time results when employees have no work to perform but are still paid for their time. For example, when a new job is being set up for production, some workers may temporarily have nothing to do. If their idleness is normal for the production process and cannot be avoided, the cost of idle time

should be charged to factory overhead control. If the cost of idle time was due to negligence or inefficiency, it should be charged to a loss account.

Guaranteed Wage and Incentive Plans

When payments to an employee are based solely on the number of units produced, the employee is said to be paid at a *piecework* rate. Many employers pay employees a minimum wage but employees can earn more if they produce more. This labor payment system benefits new employees because it guarantees them a minimum salary while they are learning their new job (during which time they usually do not produce enough units to trigger the piecework rate). Experienced employees also benefit from this system because they are provided an opportunity to earn more money as they become more efficient. If the output multiplied by the piece rate results in an amount less than the guaranteed wage, the difference is charged to factory overhead control. If the output multiplied by the piece rate results in an amount greater than the guaranteed wage, it should theoretically be charged to work-in-process inventory. Under this type of compensation system, an average employee working on a job is expected to earn not only the minimum wage but a bonus as well. Had another type of compensation system been used, the employer would probably have paid workers an amount equivalent to the minimum wage plus the average bonus.

FACTORY OVERHEAD COSTS

Factory overhead refers to the *cost pool* used to *accumulate* all indirect manufacturing costs (excluding selling, general, and administrative expenses because they are nonmanufacturing costs). Examples of factory overhead include the following:

- Indirect labor and indirect materials.
- Heat, light, and power for the factory.
- Rent on factory building.
- Depreciation on factory building and factory equipment.
- Maintenance of factory building and factory equipment.
- Property taxes on factory building.

Factory overhead costs are divided into three categories on the basis of their behavior in relation to production. The categories are (1) variable costs, (2) fixed costs, and (3) mixed costs and are described below.

- *Variable factory overhead costs.* Total variable factory overhead costs vary in direct proportion to the level of production, within the relevant range, which was previously defined as that interval of activity within which total fixed costs and per-unit variable costs remain constant; that is, the greater the number of units produced, the higher the total variable factory overhead cost. However, variable factory overhead cost *per unit* remains constant as production either increases or decreases. Examples of variable factory overhead costs are indirect materials and indirect labor.
- *Fixed factory overhead costs.* Total fixed factory overhead costs remain constant within the relevant range regardless of the varying levels of production within that range. Examples of fixed factory overhead costs are property taxes, depreciation, and rent on the factory building.
- *Mixed factory overhead costs.* Mixed factory overhead costs are neither wholly fixed nor wholly variable in nature but have characteristics of both. Mixed factory overhead costs must ultimately be separated into their fixed and variable components for purposes of planning and control. Examples of mixed factory overhead costs are factory truck rentals and factory telephone service (semivariable factory overhead costs) and factory supervisors' salaries and factory inspector salaries (step factory overhead costs).

Actual versus Normal Costing of Factory Overhead

In an actual cost system, product costs are recorded only when they are incurred. This technique is usually acceptable for the recording of direct materials and direct labor because they can be easily traced to specific jobs (job order costing) or departments (process costing). Factory overhead, because it is an indirect element of product cost, usually cannot be easily or conveniently traced to a specific job or department. As a consequence, a modification of an actual cost system, called *normal costing*, is commonly used. Under normal costing, costs are accumulated as they are incurred, with one exception: Factory overhead is *applied* to production on the basis of actual inputs (hours, units) multiplied by a predetermined factory overhead application rate. This procedure is necessary because factory overhead costs are not incurred evenly throughout a period; therefore, estimates must be made and a rate developed to apply factory overhead costs to jobs or departments as units are produced. The classification of a factory overhead cost as variable, fixed, or mixed becomes important when the predetermined factory overhead application rate is computed.

In the remainder of this chapter we present the procedures used to develop a predetermined factory overhead application rate and the method

of applying factory overhead to production. Two key factors determine the factory overhead application rate for a period: (1) estimated level of production (denominator) and (2) estimated factory overhead costs (numerator).

Estimated Level of Production

In computing the factory overhead application rate for a period, the estimated level of production (the denominator of the predetermined rate) for the next period is an important consideration because *total* factory overhead is a combination of variable, fixed, and mixed costs. (Remember that fixed and mixed costs *per unit* are both affected by the volume of production, while variable cost per unit remains constant.) The estimated level of production cannot, in the short run, exceed the firm's productive capacity. The productive capacity of a firm is dependent on many factors: physical size and condition of the factory building and factory equipment, availability of resources such as a trained labor force and various raw materials, and so forth. Under ideal situations, management usually sets the productive capacity on the basis of projected demand for the product. Architects and engineers are given the product's design, production specifications, and desired annual production capacity and are instructed to design productive facilities. However, one of the biggest problems is that the projected demand for the product, in many cases, is unknown or fluctuates annually. Should management plan for a small productive capacity and then expand as the product's demand increases? This would seem the safe way except that it is usually more economical to build the optimum productive capacity at the outset than to make costly modifications. Management could start out with a large plant and hope to grow into it. This is also uneconomical because the extra cost of the unused or idle productive capacity must be absorbed by the units produced, which results in an undesirable increase in unit cost. Many innovative approaches using sophisticated techniques have been developed to aid management in making decisions related to optimum plant capacity. For our purposes, we assume that the productive facilities are already in place.

The next problem is to estimate the number of units to produce, during the next period, within the constraints of the existing productive facility. Should the estimate be based on the plant facilities' maximum output under ideal conditions, or should the figure allow for practical considerations, such as possible machinery breakdowns and labor absenteeism? What about marketing considerations? Should estimates of production be tied into sales projections for the next period, or possibly the next few years? In reality, all the preceding factors and a significant number of others must be considered when projections are made. The following productive capacity levels may be used to project the level of production for the next period:

- *Theoretical or ideal productive capacity.* The maximum output that a department or factory is capable of producing, with no provision for either a lack of sales orders or interruptions in production (due to work stoppages, machine downtime for repairs and maintenance, setup time, holidays, weekends, etc.), is called theoretical or ideal productive capacity. At this capacity level, the plant is assumed to function 24 hours a day, 7 days a week, and 52 weeks a year without any interruptions in order to yield the highest physical output possible (i.e., 100% of plant capacity).
- *Practical or realistic productive capacity.* The maximum production attainable, with a provision for anticipated and unavoidable interruptions in production but with no provision for a lack of sales orders, is called practical or realistic productive capacity. Practical capacity is the maximum capacity expected when the plant operates at a *planned level of efficiency*.
- *Normal or long-run productive capacity.* The productive capacity based on practical productive capacity, tempered by the long-range customer demand for the product, is called normal or long-run productive capacity. Normal capacity is equal to or less than practical productive capacity. The long-range (usually 5 years) estimate of customer demand for the product is, in essence, a weighted average that smooths out seasonal, cyclical, and other variations in customer demand.
- *Expected or short-run productive capacity.* Capacity based on estimated production for the next period is called expected or short-run productive capacity. In any one period, expected productive capacity can be more than, equal to, or less than normal productive capacity. In the long run, total expected productive capacity should equal total normal productive capacity.

Comparison of Productive Capacities

The first two productive capacity levels, theoretical and practical, take into consideration only the *physical capacity* of a department or factory. Thus, if a company could sell everything it produced, these capacity levels could be used to compute the factory overhead application rate. However, this is rarely the case; most companies produce only as much as they expect to sell. Therefore, sales projections are a vital factor in the planning process and must be considered when estimating production levels. For most companies, either normal productive capacity or expected productive capacity is used to compute factory overhead costs because these two bases explicitly include projected customer demand in their estimates.

Expected productive capacity should be used in theory only when normal productive activity is difficult to determine. For example, assume that a company has a normal productive capacity of 200,000 units. Expected productive capacity for the current year is 160,000 units. Management expects production of 205,000 units in the following year. Fixed factory overhead costs are \$180,000; variable factory overhead costs are \$1.15 per unit. The factory overhead application rates computed for normal productive capacity and expected productive capacity are shown in Table 20.1. Different factory overhead application rates result because the fixed factory overhead cost is spread over a greater number of units under normal productive capacity. The fixed factory overhead application rate is \$0.90 per unit ($\$180,000/200,000$ units) under normal productive capacity, but it is \$1.125 per unit ($\$180,000/160,000$ units) under expected productive capacity.

Normal productive capacity is used by firms that believe a product's cost should be based on an *average* cost that takes into consideration production-related interruptions and recurring fluctuations in customer demand. Assuming that all other factors remain constant, normal productive capacity results in uniform product costs per unit across different time periods. The use of normal productive capacity eliminates the possibility of manipulation of unit product cost by deliberately varying production levels. That is, in the presence of fixed factory overhead, deliberately increasing production decreases unit product cost, whereas deliberately decreasing production increases unit product cost.

The use of expected productive capacity as a base usually provides a close approximation of next period's activity. Since expected productive

TABLE 20.1 Factory Overhead Application Rates

| | Expected Productive Capacity | Normal Productive Capacity |
|--|------------------------------------|----------------------------------|
| Fixed factory overhead costs | \$180,000 | \$180,000 |
| Variable factory overhead costs: | | |
| 160,000 units \times \$1.15/unit | 184,000 | — |
| 200,000 units \times \$1.15/unit | — | <u>230,000</u> |
| Total factory overhead costs | <u>\$364,000</u> | <u>\$410,000</u> |
| Divided by estimated units of production | 160,000 | 200,000 |
| Factory overhead application rate | <u>\$2.275^a</u> | <u>\$2.05^b</u> |

^a \$1.15 variable + \$1.125 fixed.

^b \$1.15 variable + \$0.90 fixed.

capacity is based on a projection of next period's production, the amount of fixed factory overhead not absorbed by production should be kept to a minimum. Proponents of this productive capacity level believe that the major purpose of applying factory overhead is to approximate actual cost per unit produced. Using expected production as the basis for applying factory overhead should provide the closest approximation (out of the four possible productive capacity levels) of unit product cost for the next period. The major drawback in using expected productive capacity is that unit costs vary across different time periods if output varies appreciably.

For example, a large automobile manufacturer used expected productive capacity as a basis for computing its factory overhead application rate for each period. Because its sales price was based on production costs, the expected productive capacity exaggerated the effect of business cycles. In years when customer demand was low, fewer cars would be produced, which would cause the unit cost of production to increase, with a corresponding increase in sales price. This would lead to further decreases in the number of cars sold. In years when customer demand was high, more cars would be produced, causing the unit cost of production to decrease, with a corresponding decrease in sales price. This would lead to further increases in the number of cars sold. To correct this situation, the company switched to normal productive capacity as a basis for computing its factory overhead application rate and setting its sale price.

Idle Capacity and Excess Capacity

Although no company can realistically hope to achieve full utilization of all its available productive capacity, the cost accounting information should account for the cost of unused productive capacity in such a manner as to lead to an appropriate response on the part of management. The cost of unused capacity should be separated into the cost of *excess capacity* and the cost of *idle capacity*.

The cost of excess capacity is a period cost. If a loss account is charged, management is made aware that something must be done to eliminate or at least reduce existing facilities that are in excess of what the sales department can ever hope to sell in the long run. For that portion of the existing facilities that cannot be reduced, an alternative use should be found.

The cost of idle capacity is a product cost. Existing facilities temporarily unused as a result of seasonal and cyclical variations in customer demand represents the company's idle capacity. This is unavoidable and a necessary cost of providing a normal level of productive capacity.

Estimated Factory Overhead Costs

Once the estimated level of production has been determined, a company must develop some means of arriving at a satisfactory estimate of factory overhead costs—the numerator of the predetermined rate. A budget of estimated factory overhead costs for the next period is usually prepared. Each item must be classified as either fixed factory overhead or variable factory overhead. (Mixed costs have to be divided into their fixed and variable components.) Total fixed costs do not change as production levels change within the relevant range; therefore, the level of production is not a factor in determining total fixed costs. Total variable costs, on the other hand, vary in direct proportion to changes in the level of production; therefore, the level of production is a factor in determining total variable cost. Estimated total variable factory overhead equals the variable factory overhead cost per unit multiplied by the estimated level of production. Hence, the level of production for the next period must first be determined in order to estimate the total variable portion of factory overhead costs.

For example, assume the following information for 20X2 for the Stone Corporation, which manufactures one product in their overseas plant, in one department, and uses a process cost system to accumulate costs:

| | |
|--|-----------------|
| Normal capacity, in units | 250,000 |
| Normal capacity, in direct labor hours (2 direct labor hours per unit) | 500,000 |
| Relevant range of production: | |
| In units | 100,000–400,000 |
| In direct labor hours | 200,000–800,000 |
| Factory <i>overhead</i> costs: | |
| <i>Variable factory overhead:</i> | |
| Indirect materials, average per unit | \$0.50 |
| Indirect labor costs, average per hour | \$5.00 |
| Indirect labor hours (3% of 500,000 direct labor hours) | 15,000 |
| Fuel to run factory equipment, average per machine hour | \$30.00 |
| Equipment hours required (3% of 500,000 direct labor hours) | 15,000 |
| <i>Fixed factory overhead:</i> | |
| Factory rent | \$300,000 |
| Depreciation of factory equipment | \$50,000 |

TABLE 20.2 Stone Corporation: Static Factory Overhead Budget for 20X2

| | |
|---|--------------------|
| Estimated units of production at normal capacity | <u>250,000</u> |
| Estimated direct labor hours at normal capacity (2 direct labor hours per unit) | <u>500,000</u> |
| <i>Variable factory overhead costs:</i> | |
| Indirect materials (\$0.50/unit × 250,000 units) | \$125,000 |
| Indirect labor (\$5.00/hour × 15,000 indirect labor hours) | 75,000 |
| Fuel for equipment (\$30.00/machine hour × 15,000 machine hours) | <u>450,000</u> |
| Total variable factory overhead costs | <u>\$650,000</u> |
| <i>Fixed factory overhead costs:</i> | |
| Factory rent | \$300,000 |
| Depreciation of factory equipment | <u>50,000</u> |
| Total fixed factory costs | <u>\$350,000</u> |
| Total factory overhead costs | <u>\$1,000,000</u> |

A budget of the estimated factory overhead costs for the next period, 20X2, is shown in Table 20.2. This is called a static budget because it represents only one level of production (i.e., 250,000 units).

Determination of Factory Overhead Application Rates

Once the level of production and total factory overhead costs for the next period have been estimated, the predetermined factory overhead application rate for the next period can be computed. Factory overhead application rates are generally stated in terms of dollars per unit of estimated activity of some base (called denominator activity). There are no definitive rules for determining the base to use as the denominator activity. However, there must be a direct relationship between the base and factory overhead costs. Also the method used to determine the factory overhead application rate should be the simplest and least costly to compute and apply. Once total factory overhead costs have been estimated and the base chosen, the normal capacity activity level must be estimated in order to compute the factory overhead application rate. The formula for computing the factory overhead application rate, which is the same regardless of the base chosen, is as follows:

$$\text{Factory overhead application rate per unit, hour, dollar, etc.} = \frac{\text{Estimated factory overhead costs}}{\text{Estimated base at denominator activity}}$$

Bases commonly used to compute the factory overhead application rate are: (1) units of production, (2) direct materials cost, (3) direct labor cost, (4) direct labor hours, and (5) machine hours.

Units of Production

This method is very simple because data on the units produced is readily available for applying factory overhead. The formula is as follows:

$$\text{Factory overhead application rate per unit of production} = \frac{\text{Estimated factory overhead costs}}{\text{Estimated units of production}}$$

The data for the following illustrations is based on the Stone Corporation's static factory overhead budget at the normal productive capacity level (Table 20.2). The estimated factory overhead costs for the period are \$1,000,000 and normal productive capacity is 250,000 units. The factory overhead application rate using the units of production method would be computed as follows:

$$\frac{\$1,000,000}{250,000 \text{ units}} = \$4.00 \text{ per unit of production}$$

This method applies factory overhead equally to each unit produced and is appropriate when a company or department manufactures only one product.

Direct Materials Cost

This method is suitable when it can be determined that a direct relationship exists between factory overhead cost and direct materials cost. When direct materials are a very large part of total cost, it may be inferred that the factory overhead costs are directly related to direct materials. The formula is as follows:

$$\frac{\text{Estimated factory overhead costs}}{\text{Estimated direct materials cost}} = \text{Percentage of direct materials cost}$$

For example, Stone Corporation's estimated factory overhead cost for the period is \$1,000,000; assume that the estimated direct materials cost is \$500,000. Using direct materials cost as the base, the factory overhead application rate is computed as follows:

$$\frac{\$1,000,000}{\$500,000} = 200\% \text{ of direct materials cost}$$

One problem in using direct materials cost as a base where more than one product is manufactured is that different products require varying quantities and types of direct materials with different acquisition costs. Therefore, different factory overhead application rates should be determined for each product. As can be seen, we are beginning to move away from one of our objectives—simplicity with the use of multiple rates. This should indicate to management that perhaps another base would be more appropriate.

Direct Labor Cost

This is the most widely used base because direct labor costs are generally closely related to factory overhead cost, and payroll data is readily available. It therefore meets our objectives of having a direct relationship to factory overhead cost, being simple to compute and apply, and requiring little, if any, additional cost to compute. Thus this method is appropriate when a direct relationship exists between direct labor cost and factory overhead. (There are, however, situations where there is little relationship between direct labor costs and factory overhead and this method would not be appropriate. For example, factory overhead costs may be composed largely of depreciation and equipment-related costs.) The formula is as follows:

$$\frac{\text{Estimated factory overhead costs}}{\text{Estimated direct labor cost}} = \text{Percentage of direct labor cost}$$

If estimated factory overhead costs are \$1,000,000 and estimated direct labor costs are \$2,000,000 (500,000 direct labor hours at an assumed \$4 per direct labor hour at their overseas plant), the Stone Corporation's factory overhead application rate would be computed as follows:

$$\frac{\$1,000,000}{\$2,000,000} = 50\% \text{ of direct labor cost}$$

If there is a direct relationship between factory overhead cost and direct labor cost, but wage rates vary greatly within departments, the following base may be more preferable.

Direct Labor Hours

This method is appropriate when there is a direct relationship between factory overhead costs and direct labor hours, and when there is a significant disparity in hourly wage rates. Timekeeping records must be accumulated to provide the data necessary for applying this rate. The formula is as follows:

$$\frac{\text{Estimated factory overhead costs}}{\text{Estimated direct labor hours}} = \text{Factory overhead application rate per direct labor hour}$$

Assume that the Stone Corporation's estimated factory overhead for the period is \$1,000,000 and estimated direct labor hours are 500,000 (250,000 units at 2 direct labor hours per unit). The factory overhead application rate, based on direct labor hours, would be computed as follows:

$$\frac{\$1,000,000}{500,000 \text{ direct labor hours}} = \$2.00 \text{ per direct labor hour}$$

This method, like the direct labor cost method, would be inappropriate if factory overhead costs were composed of costs unrelated to labor activity.

Machine Hours

This method uses the time required for machines to perform similar operations as a base in computing the factory overhead application rate. This method is appropriate when a direct relationship exists between factory overhead costs and machine hours. This generally occurs in companies or departments that are largely automated so that the majority of factory overhead costs consist of depreciation on factory equipment and other equipment-related costs. The formula is as follows:

$$\frac{\text{Estimated factory overhead costs}}{\text{Estimated machine hours}} = \text{Factory overhead application rate per machine hour}$$

Assume that the Stone Corporation's estimated factory overhead costs for the period are \$1,000,000 and estimated machine hours are 15,000, as per Table 20.2. The factory overhead application rate would be computed as follows:

$$\frac{\$1,000,000}{15,000 \text{ machine hour}} = \$66.70 \text{ per machine hour}$$

The disadvantages of this method are the additional cost and time involved in summarizing total machine hours per unit. Because every company is different, the decision regarding which base is appropriate for a particular manufacturing operation must be made by management after careful analysis.

Single Plantwide versus Multiple Departmental Factory Overhead Application Rates

A single plantwide factory overhead application rate can be used either when a single product is being manufactured or when the different products being manufactured pass through the same series of productive departments and are charged similar amounts of applied factory overhead. Multiple departmental factory overhead application rates are preferable when the different products being manufactured either do not pass through the same series of productive departments or, if they do, they should be charged dissimilar amounts of applied factory overhead because of the differing amounts of attention each product receives.

Separate Variable and Fixed Factory Overhead Application Rates

Some companies prefer to apply factory overhead to production using separate application rates for variable and fixed factory overhead because, as we have shown, variable costs and fixed costs do not behave the same as activity changes. Separate application rates are especially useful for control purposes via the analysis of applied factory overhead costs versus actual factory overhead costs.

If direct labor hours are used as the base to apply factory overhead for the Stone Corporation, the factory overhead application rate for 20X2 can be easily divided into separate variable and fixed factory overhead application rates as follows:

$$\text{Variable factory overhead application rate} = \frac{\$650,000}{500,000 \text{ direct labor hours}} = \$1.30 \text{ per direct labor hour}$$

$$\text{Fixed factory overhead application rate} = \frac{\$350,000}{500,000 \text{ direct labor hours}} = \$0.70 \text{ per direct labor hour}$$

$$\text{Factory overhead application rate} = \frac{\$1,000,000}{500,000 \text{ direct labor hours}} = \$2.00 \text{ per direct labor hour}$$

Applied Factory Overhead Cost

After the factory overhead application rate has been determined, it is used to apply (or match) estimated factory overhead costs to production. The estimated factory overhead costs are applied to production on an ongoing basis as goods are manufactured, according to the base used (i.e., as a percentage of direct materials costs or direct labor cost or on the basis of direct labor

hours, machine hours, or units produced). For example, assume that the factory overhead application rate was determined to be \$2.00 per direct labor hour, using direct labor hours as a base, and that 100,000 actual direct labor hours were worked. Then \$200,000 ($100,000 \times \2.00) of estimated factory overhead would have been applied to production during the period in relation to the direct labor hours that were actually worked.

Actual Factory Overhead Costs

Actual factory overhead costs are usually incurred daily and recorded periodically in the general and subsidiary ledgers. Subsidiary ledgers permit a greater degree of control over factory overhead costs as related accounts can be grouped together and the various expenses incurred by different departments can be described in detail.

Factory overhead encompasses many different items and involves a variety of accounts. For this reason, some companies develop a chart of accounts that indicates the account specific factory overhead costs are to be charged. A sample chart of accounts relating only to factory overhead costs is shown in Table 20.3.

Accounting for Actual Factory Overhead Costs

Factory overhead charges are gathered from many sources, such as the following:

- *Invoices*: Bills received from suppliers or service organizations.
- *Vouchers*: Paid bills.
- *Accruals*: Adjustments for items like accrued utilities payable.
- *Year-end adjusting entries*: Adjustments for items like depreciation and amortization expense.

TABLE 20.3 Chart of Accounts: Factory Overhead

| Indirect Materials and Indirect Labor | Depreciation—Factory Machinery |
|--|---|
| Supervision | Factory rent |
| Light—factory | FICA tax—factory workers (employer's share) |
| Electricity—factory | Unemployment taxes—factory workers |
| Fuel—factory | Insurance—factory property |
| Water—factory | Compensation insurance—factory workers |
| Small tools—factory | Group insurance—factory employees |
| Repairs and maintenance of factory equipment | Property taxes—factory |
| Depreciation—factory building | |

Manufacturing companies commonly use a departmental factory overhead cost sheet for the analysis of factory overhead costs. Each department maintains a departmental factory overhead cost sheet that is a subsidiary ledger of the Factory Overhead Control account. These sheets are detailed records of the amount of total factory overhead actually incurred for each department. Reconciliation of the control and subsidiary ledgers should be performed at regular intervals.

Journalizing Factory Overhead

The journal entries to record factory overhead costs under either a job order cost system or a process system are basically the same. The major difference is that under a job order cost system applied factory overhead is accumulated by jobs whereas under a process cost system applied factory overhead is accumulated by departments. Both actual and applied factory overhead costs must be recorded.

Analysis of Underapplied or Overapplied Factory Overhead

The difference between applied factory overhead and actual factory overhead should be analyzed to determine the cause(s). The difference or variances can usually be isolated into the following categories:

- *Price variance.* Results when a company spends more or less on factory overhead than anticipated. For example, an unexpected increase in the price of indirect materials would increase total variable factory overhead costs; an unexpected increase in the price of factory insurance would increase total fixed factory overhead costs.
- *Efficiency variance.* Results when workers are more or less efficient than planned. That is, workers may take longer than expected to generate production. Consequently, equipment, for example, used to produce the units must be run longer than it should be run, which increases total factory overhead costs because more fuel and other equipment-related costs are unnecessarily incurred.
- *Production volume variance.* Results when the activity level used to calculate the predetermined factory overhead application rate is different from the actual production level achieved. A production volume variance is a fixed factory overhead phenomenon that results from having to apply fixed factory overhead to production as if it were a variable cost in order to determine a product's cost. For example, when the actual production is less than denominator activity, fixed factory overhead will be underapplied.

In Chapter 24, where we cover standard costs, we present a detailed discussion of the computation and analysis of the above variances.

Accounting for the Difference between Applied and Actual Factory Overhead

The amount of factory overhead applied during a period will seldom equal the actual factory overhead incurred because the predetermined factory overhead application rate is based on both an estimated numerator (factory overhead costs) and an estimated denominator (productive capacity). Insignificant differences are usually treated as a period cost by adjusting cost of goods sold. Significant differences should be prorated to work-in-process inventory, finished goods inventory, and cost of goods sold, in proportion to the unadjusted *factory overhead balance* in each account. The objective is to allocate the under- or overapplied factory overhead to those accounts that were distorted by using what unintentionally proved to be the incorrect application rate and thereby to adjust their ending balances to approximate what they would have been if the correct application rate had been used. When a job order cost system is used to accumulate costs, the factory overhead applied to individual jobs must also be adjusted. Under a process cost system, the factory overhead assigned to each department must be adjusted.

ACTIVITY-BASED COSTING

Activity-based costing, better known by its acronym *ABC*, is an expanded cost allocation process that assigns indirect costs to actual activities, then to the products based on their use of the activity. By focusing on the activity that drives the cost, activity-based costing attempts to accurately trace the use of resources going into individual products. A correctly designed activity-based costing system provides better information about the indirect costs and profitability associated with individual products, facilitating more accurate decision making.

In the past, when production was very labor intensive the allocation of indirect costs based on labor was a fairly accurate measure. As the manufacturing process became more automated, overhead became a bigger component of total production cost. In some companies labor has shrunk to less than 5% of product costs while overhead has risen to as much as 75%. It becomes obvious that a system that measures indirect costs based on labor is flawed. Through the use of multiple cost drivers (source of the activity's cost) management can trace the cost of activities to the products that use the resources.

Implementation of an Activity-Based Costing System

The implementation of an activity-based costing system requires a great deal of cooperation and teamwork from all functional areas within the business. An ABC project team must be formed to include representatives from accounting, manufacturing, information systems, engineering, and marketing as well as any other department whose activities are going to come under scrutiny. Accountants alone will not be able to develop an effective activity-based costing system because it requires full detailed knowledge of exactly what goes into the manufacturing of a product or delivery of a service. This knowledge can come only from all parties involved in the complete process. Because of the detail, such a system is more costly than a standard costing system and should be undertaken only if the improved decision-making capabilities will be fully utilized and can justify the cost.

Steps Involved in Application

Three steps are required in applying costs based on use of activities. First, identify all activity centers and the resources that are being consumed by these activity centers. Table 20.4 presents examples of activities in a production environment.

Second, the cost driver(s) behind each activity must be identified and the cost per driver unit must be calculated. A cost driver is a factor that causes an activity's cost. Table 20.4 presents examples of cost drivers. When identifying cost drivers it is important to find ones that most directly cause the cost of the activity, or the results that are generated will be inaccurate. An activity-based costing system is only as accurate as the information that goes into it. Information on the true consumption of resources must be provided by an ABC system to be an improvement over a traditional costing system. As production becomes more complex, the number of cost drivers will increase. The formula that calculates cost driver per unit is as follows:

TABLE 20.4 Types of Activities and Examples of Cost Drivers for Each Activity

| Type of Activity | Cost Driver for Activity |
|-----------------------|---------------------------------|
| Purchase of materials | Quantity of materials purchased |
| Machine setups | Number of machine setups |
| Computer usage | Computer time |
| Running of machines | Machine hours |
| Inspections | Hours of inspection time |
| Testing | Hours of testing time |
| Prepare billings | Customers served |

$$\text{Cost driver rate} = \frac{\text{Estimated overhead cost for the activity per unit}}{\text{Estimated number of cost driver units}}$$

The estimated number of cost driver units is the volume of the activity, such as number of units produced, number of setups, or hours of inspection.

The third step involves assigning the costs of the activities consumed to the individual units based on their use of the activity. By multiplying the cost driver rate per unit calculated in the first step by the amount of activity used to produce the item or service, indirect costs can be accurately allocated.

Traditional Cost Allocation System versus ABC System

Unlike a standard cost accounting system, which views a company as many different departments working together to manufacture a product or provide a service, ABC views a company as many small activities that are performed in an effort to manufacture a product or provide a service in a manner that is most cost effective to the organization as a whole.

Companies using a traditional cost system compute the predetermined indirect cost rate for each department or the factory as a whole. Companies using activity-based costing compute the rate for each cost driver within each activity center. ABC was developed in the 1980s as a device to help companies associate costs with products, thus helping companies better price their products.¹ Instead of arbitrarily associating overhead costs to products, ABC traces through the indirect costs and ties the associated indirect costs to products. Successful application of ABC allows companies to identify products on the basis of profitability.

Both traditional and activity-based methods of costing reach the same bottom line for total costs, but ABC allows accountants to charge costs to products much more accurately than the conventional method because it breaks down overhead far more precisely. Table 20.5 shows a breakdown of costs in a typical production department using both methods. The table shows that both methods result in the same bottom line but an ABC system provides a more detailed and accurate breakdown of costs.

Example of Activity-Based Costing

Healthy Yogurt Company manufactures two kinds of yogurt, plain and low-fat with strawberries. Production runs of the plain yogurt are rather simple with only one setup. Production runs for the low-fat yogurt are more complex because of the fresh fruit and require five setups. In the past, all

¹ Robert S. Kaplan and W. J. Bruns, *Accounting and Management: A Field Study Perspective* (Boston: Harvard Business School Press, 1987).

TABLE 20.5 Example of Traditional Costing versus Activity-Based Costing

| Traditional Accounting | | Activity-Based Costing | |
|------------------------|------------------|------------------------|------------------|
| Materials | \$445,000 | Order materials | \$386,000 |
| | | Issue purchase orders | 37,000 |
| Salaries | 316,000 | Schedule production | 35,000 |
| | | Internal processing | 86,000 |
| Fixed overhead | 131,000 | Inspections | 57,000 |
| | | Machine tuning costs | 256,000 |
| | | Testing | <u>35,000</u> |
| Total Cost | <u>\$892,000</u> | Total Cost | <u>\$892,000</u> |

overhead was allocated based on direct labor hours; however, it has been realized that this was giving a distorted picture of the actual overhead being expended on each of the products. For the 230,000 units of plain yogurt and the 125,000 units of low-fat-with-strawberries yogurt that were produced, the breakdown of costs is as follows:

| Activity | Cost Driver | Cost per Unit |
|----------------------------------|-----------------------|-------------------------|
| Plain Yogurt | | |
| Purchasing of materials | 100,000 gal. milk | \$0.40 per gal. |
| Machine setups | 2 | \$500 per setup |
| Inspections | 25 | \$80 per inspection hr. |
| Running machines | 925 hours | \$12 per hr. |
| Prepare shipping orders | 400 | \$2.50 per order |
| Low-Fat with Strawberries | | |
| Purchasing of materials | 58,000 gal. skim milk | \$0.40 per gal. |
| Purchasing of materials | 1,100 lb strawberries | \$0.35 per lb. |
| Machine setups | 5 | \$500 per setup |
| Inspections | 45 | \$80 per inspection hr. |
| Running machines | 540 hours | \$12 per hr. |
| Prepare shipping orders | 225 | \$2.50 per order |

Using activity-based costing methods, the total cost and per-unit costs for the plain yogurt and low-fat yogurt with strawberries would be computed as follows:

| Plain Yogurt | | | |
|---------------------------------------|------------------------------|--------------------------------|--------------------|
| | Rate | Cost Driver (in Units) | Cost Allocated |
| Purchasing of materials | \$0.40 per gal. | 100,000 gal. milk | \$40,000 |
| Machine setups | \$500 per setup | 2 | \$1,000 |
| Inspections | \$80 per inspect. hr. | 25 | \$2,000 |
| Running machines | \$12 per hr. | 925 hours | \$11,100 |
| Prepare shipping orders | \$2.50 per order | 400 | \$1,000 |
| | | | <u>\$55,100</u> |
| Low-Fat with Strawberries | | | |
| | Rate | Cost Driver (in Units) | Cost Allocated |
| Purchasing of materials | \$0.40 per gal. | 58,000 gal. milk | \$23,200 |
| Purchasing of materials | \$0.35 per lb. | 1,100 lbs of straw- berries | \$385 |
| Machine setups | \$500 per setup | 5 | \$2,500 |
| Inspections | \$80 per inspect. hr. | 45 | \$3,600 |
| Running machines | \$12 per hr. | 540 hours | \$6,480 |
| Prepare shipping orders | \$2.50 per order | 225 | \$562.50 |
| | | | <u>\$36,727.50</u> |
| | Plain | Low-Fat | |
| Manufacturing Over- head per Unit: | \$0.24 per unit ^a | \$0.29 per unit ^b | |

^a \$55,100 cost allocated to plain yogurt/230,000 units produced.

^b \$36,727.50 cost allocated to low-fat yogurt/125,000 units produced.

ABC fits well into performance evaluation systems, such as the balanced scorecard, but it does require an additional layer of cost information. ABC has been overshadowed by other metrics, such as economic value added.²

BOTTOM LINE

- Materials are the basic substances that are transformed into finished goods in the production process.

² David M. Katz, "Activity-Based Costing (ABC)," *CFO.com*, December 31, 2002.

- Materials costs can be broken down into direct and indirect costs; this classification is usually based on the materials' relationship to the finished product.
- Accounting for materials in a manufacturing company usually involves two activities: the purchase of materials (requiring a purchase requisition, purchase order, and receiving report), and the issuance of materials (requiring a materials requisition form).
- Materials may be entered into the accounting records under either the periodic or the perpetual system. Efficient inventory control keeps costs down and helps production run.
- Labor is the physical or mental effort expended in the production of a product.
- Labor costs can be broken down into direct and indirect costs; this classification is usually based on the employee's relationship to the finished product.
- The accounting for labor in a manufacturing company generally involves three activities: timekeeping, computation of total payroll, and allocation of payroll costs.
- Factory overhead costs may be classified into the following three categories: variable, fixed, or mixed. The classification of factory overhead costs is based on their behavior relative to production; that is, do they vary according to units produced, or remain fixed over a wide range of production?
- The range within which fixed costs remain constant is called the relevant range. The wider the relevant range for a cost, the more likely it will be classified as fixed.
- A predetermined overhead factory application rate is commonly used to apply estimated overhead to production.
- Factory overhead application rates are usually computed as a percentage or dollar amount of some form of production. Any base may be used as long as it relates to factory overhead cost behavior and is relatively simple to apply.
- Factory overhead is applied to jobs (job order costing) or departments (process costing) at a predetermined rate as production takes place.
- Activity-based costing is an expanded cost allocation process that assigns indirect costs to actual activities, then to the products based on their use of the activity.
- By focusing on the activity that drives the cost, activity-based costing attempts to accurately trace the use of resources going into individual products.

Job Order and Process Costing

AGENDA

- Item 1* Define job order costing and identify the types of industries that would be most apt to use this system.
- Item 2* Demonstrate the mechanics of a job order costing system.
- Item 3* Define and illustrate operation costing.
- Item 4* Define and illustrate project costing.
- Item 5* Define process costing and discuss the main objectives and characteristics of a process cost system.
- Item 6* Briefly discuss the use of a constant-flow accumulation system and a just-in-time inventory system.
- Item 7* Discuss, in depth, the cost of production report and how it aids management in analyzing the total costs and unit costs of each department.
- Item 8* Identify and set up the four steps (schedules) that make up a cost of production report.
- Item 9* Adjust unit costs when materials are added to production after the first department.
- Item 10* Discuss the effect of beginning work-in-process inventories.

Most nonaccountants are unaware of the volume of paperwork that is processed in a manufacturing company. Small and medium-sized manufacturing companies may handle thousands of requisitions, purchase orders, receiving reports, vendors' invoices, vouchers, checks, stock issues, and similar business documents each month. A large manufacturing company may handle tens of thousands of such documents a month. Thus, it is obvious that clearly defined cost accumulation systems are required to control this volume of paperwork.

The accumulation and classification of routine product cost data are very important and time-consuming tasks. Cost accumulation in general is

the organized collection of cost data via a set of procedures or systems. Cost classification is the grouping of all manufacturing costs into various categories in order to meet the needs of management.

A figure indicating the *total cost* of production provides little useful information about a company's operations, since the volume of production (and therefore cost) varies from period to period. Thus, some common denominator, such as *unit costs*, must be available in order to compare various volumes and costs. Unit cost figures can be readily computed by dividing the total cost of goods manufactured by the number of units produced. Unit costs are stated in the same terms of measurement used for units of output, such as cost per *ton*, per *gallon*, per *foot*, per *assembly*, and so on.

Unit costs also facilitate the valuation of cost of goods sold and ending inventories. For example, assume that 5,000 units are produced at a total cost of \$8,000, or \$1.60 per unit. If 3,500 units are sold, the ending finished goods inventory consists of 1,500 units. The computation for cost of goods sold and ending finished goods inventory is as follows:

| Description | Units | Total Cost |
|--|--------------|----------------|
| Total production | <u>5,000</u> | <u>\$8,000</u> |
| Cost of goods sold (3,500 units at \$1.60) ^a | 3,500 | \$5,600 |
| Ending finished goods inventory (1,500 units at \$1.60) ^a | <u>1,500</u> | <u>2,400</u> |
| Total | <u>5,000</u> | <u>\$8,000</u> |

^a \$8,000/5,000 units = \$1.60 per unit.

The most common cost accumulation systems used to account for the cost of production are the job order costing and the process costing systems. Both systems will be discussed in this chapter.

COMPARISON OF JOB ORDER AND PROCESS COST ACCUMULATION SYSTEMS

A job order cost accumulation system is most suitable where a single product or batch of products is manufactured according to a customer's specifications. A process cost accumulation system is used when products are manufactured by either mass production techniques or continuous processing and is most suitable when homogeneous products are manufactured in large volumes. A customized cabinet builder would use a job order cost system, whereas a manufacturer of 8-ounce jars of peanut butter would use a process cost system.

Under a job order cost accumulation system, the three elements of a product's cost (direct materials, direct labor, and factory overhead) are accumulated according to identifiable jobs. Individual work-in-process inventory subsidiary cost sheets are set up for each job and are charged with the cost incurred in the production of the specifically ordered unit. Upon completion of each job, its cost is transferred from work-in-process to finished goods inventory.

Under a process cost system, the three basic elements of a product's cost are accumulated according to department or cost center. Individual *work-in-process* inventory accounts are set up for each department and are charged with the costs incurred in the processing of the units that pass through them. Upon completion of the process, the cost of work-in-process inventory in the last department is transferred to finished goods inventory. Figure 21.1 presents diagrams of a job order and a process cost system.

JOB ORDER COSTING

A job order costing system is most suitable where the products manufactured differ in materials and conversion requirements. Each product is made according to a customer's specifications and the price quoted is closely tied to estimated cost. The cost incurred in manufacturing a particular job must therefore be matched to the goods produced. Examples of types of companies that might use job order costing are printing, shipbuilding, aircraft, construction, and engineering firms.

Under a job order cost system, the three basic elements of cost—direct materials, direct labor, and factory overhead—are accumulated according to assigned job numbers. The unit cost for each job is obtained by dividing the total units for the job into the job's total cost. A cost sheet is used to summarize the applicable job costs. Selling and administrative expenses, which are based on a percentage of manufacturing cost, are listed on the cost sheet to arrive at total cost.

In order for a job order cost system to function properly, it must be possible to identify each job physically and segregate its related costs. Direct material requisitions and direct labor costs carry the particular job number; factory overhead is usually applied to individual jobs based on a predetermined factory overhead application rate. The profit or loss can be determined for each job and the unit cost computed for purposes of inventory costing. Schedules are prepared to accumulate the information for the required journal entries.

FIGURE 21.1 Comparison of Job Order and Process Costing Systems

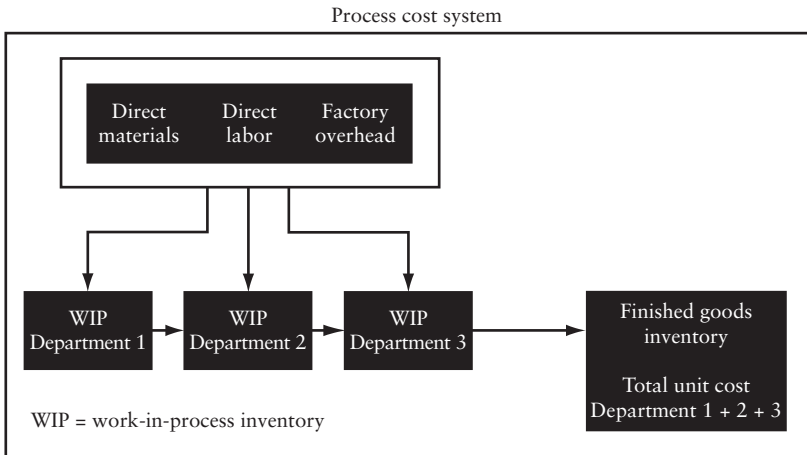
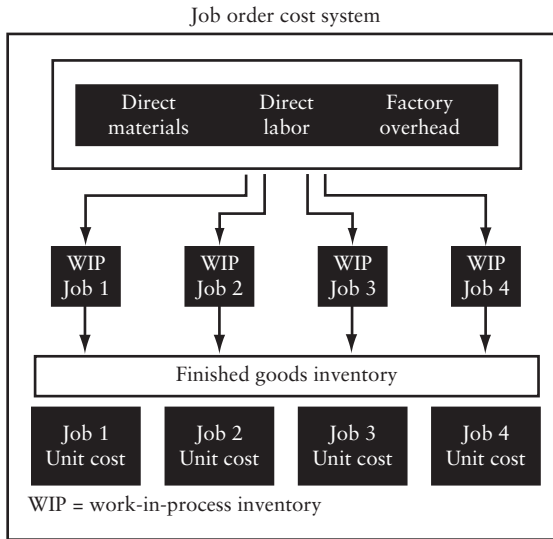

Purchase of Materials

Raw materials and supplies used in production are ordered by the purchasing department. These materials are kept in a materials storeroom under the control of a clerk and are issued only when a properly approved requisition is presented.

Issuance of Materials

The next step in the manufacturing process is to obtain the needed raw materials from the materials storeroom. There is one source document for the issuance of materials in a job order cost system—a materials requisition.

Any issuance of materials by the materials clerk must be substantiated by a materials requisition approved by the production manager or the department supervisor. Each requisition form shows the job order number, the department number, and the quantities and description of materials requested. The materials clerk enters the unit cost and total cost on the requisition form.

On a regular basis, perhaps weekly, materials requisitions are sorted by job number and the totals recorded on a cost summary sheet.

When direct materials are put into production, a journal entry is made to record the addition of materials to work-in-process inventory. When indirect materials are requisitioned, they are generally charged to a departmental Factory Overhead Control account. Indirect materials costs are included in the factory overhead application rate, as it is often impractical to trace these materials to each job.

Labor Cost

There are two source documents for labor in a job order cost system—a time card and a labor job ticket. Time (or clock) cards are inserted in a time clock by employees each day when they arrive, go to and return from lunch, take breaks, and leave work for the day. This procedure mechanically shows a record of total hours worked each day by each employee and thus provides a reliable source for the computation and recording of payroll. Labor job tickets are prepared daily by each employee indicating the job worked on and the number of hours worked. The wage rate of the employee is inserted by the payroll department. The sum of the labor cost and hours incurred on various jobs (labor tickets) should be equal to the total labor cost and total labor hours for the period (time cards).

At periodic intervals, time cards are summarized to record the payroll, and labor job tickets are summarized to be charged to work-in-process inventory or factory overhead control. Time card and job ticket hours should be reconciled.

Factory Overhead

The third element to be included in determining the total cost in a job order cost system is factory overhead. There is one source document for the

computation of factory overhead costs in a job order cost system—a departmental factory overhead cost sheet, which each department maintains. This is a subsidiary ledger of the Factory Overhead Control account. Reconciliation of the control and subsidiary ledgers should be performed at regular intervals. It should be noted, however, that factory overhead costs may be recorded for the factory in total and then distributed to production departments for ultimate distribution to jobs.

The distribution of factory overhead to jobs is based on a predetermined factory overhead application rate. Factory overhead application rates are expressed in terms of direct labor hours, direct labor dollars, direct materials dollars, machine hours, or some other reasonable basis. When factory overhead is not accumulated on a factorywide level for distribution to several departments, *each department will generally have a different rate*. Department A's rate may be \$2.30 per direct labor hour while Department B's rate may be \$2.70 per direct labor hour. In addition, each department may use separate bases to determine the rate of application. For example, factory overhead may be based on direct labor hours in Department A and on machine hours in Department B. Application rates vary because of the differences in activity and functions of individual production departments.

To clarify, the production department applies factory overhead at a rate of 75% of direct labor cost. Assume total direct labor cost for a job amounted to \$3,500. Factory overhead applied would therefore be \$2,625 (75% of \$3,500).

Job Order Cost Sheet

A job order cost sheet summarizes the amount of direct materials, direct labor, and applied factory overhead for each job processed. Direct materials and direct labor cost information is obtained from materials requisitions and labor summaries, and is posted to the job order cost sheet daily or weekly. Factory overhead is usually applied at the end of the job, as are selling and administrative expenses.

Job order cost sheets are designed to provide information needed by management and therefore will vary according to management's desires or needs. For example, some forms include selling and administrative expenses and selling price so that estimated profit can be readily determined for each job. Other forms provide only basic factory cost data—direct materials, direct labor, and factory overhead. Forms will also vary depending on whether a firm is departmentalized. Figure 21.2 presents a general flow of costs in a job order costing system where more than one job is involved.

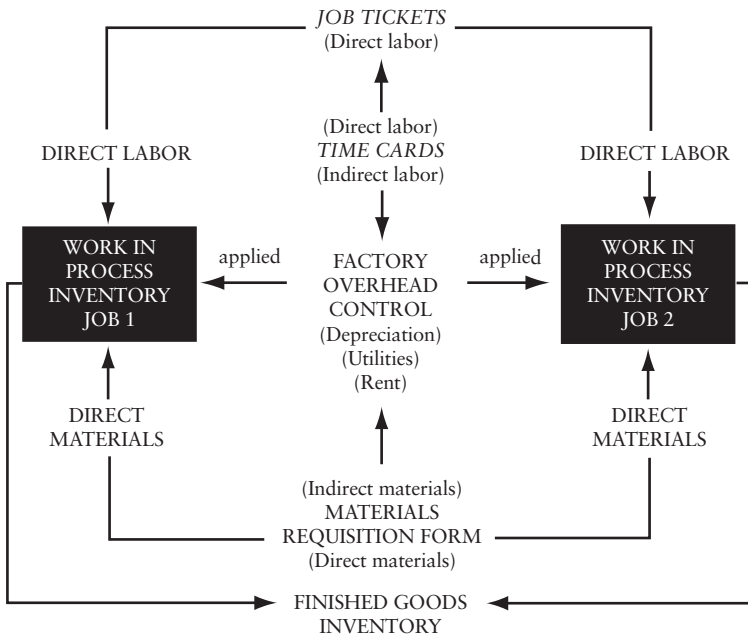
FIGURE 21.2 Flow of Costs for More than One Job

OPERATION COSTING

Operation costing (also known as *specification costing*) is a cost accumulation system that accounts for costs in a manner similar to that of a job order costing system. Under an operation costing system, costs are accumulated by operating or work stations and allocated to individual batches (orders). An operating station is designed around a particular function in a production process. For example, an assembly department of a large manufacturing corporation may have the following operating stations: welding, soldering, gluing, and so on. Units are manufactured in batches (*batch manufacturing*) on the basis of specific work orders. When an order is received it is given a batch number and is routed through whatever operating stations are necessary to complete the job. Work stations often stock large quantities of inventories in order to keep production flowing to avoid idle time.

Product costs are accumulated by batches. The cost of direct materials used is traced and charged to individual batches. Direct labor and factory overhead (conversion costs) are not directly charged to a specific batch but instead *applied* in a manner similar to the application of factory overhead. A predeter-

mined conversion cost application rate for each operating station is estimated before the period's production begins. This rate may be computed as follows:

$$\begin{aligned} & \text{Predetermined conversion cost application rate} \\ &= \frac{\text{Estimated conversion cost}}{\text{Estimated base (machine hours, units produced, etc.)}} \end{aligned}$$

The amount of detailed record keeping for direct labor is normally reduced by this procedure because the workers have to account for only the total hours worked per shift. It is not necessary for them to account for the time spent on each batch that passes through their operation. If many different batches are processed during a shift, the reduction in bookkeeping (and therefore costs) could be significant.

In summary, when a batch passes through an operating station, it is directly charged with any direct materials used. Direct labor and factory overhead are applied to the batch by multiplying the predetermined conversion cost application rate by the actual machine hours used (assuming machine hours as a base) by the operating station to complete the batch. Any over- or underapplied conversion costs at the end of a period are accounted for in the same manner as in job order costing.

PROJECT COSTING

A company that builds aircraft carriers would most likely accumulate costs in a system very similar to that of job order costing. A modification of job order costing, which would be appropriate for shipbuilding, is project costing. A *project* is similar to a *job* in that costs are accumulated by projects or jobs and each product is made according to customer's specifications. Job order costing is usually used in short-term manufacturing processes, such as printing; however, project costing is often used when production is expected to take months or years. The building of a bridge may take years and is considered a project; the typesetting and duplication of 100 resumes is a job. Jobs are often repetitive in nature whereas projects are often unique.

The long-term nature and high costs of most projects require the development of effective control procedures. For example, when the Department of Defense (DoD) receives an appropriation for the development and construction of a new generation of fighter planes, the cost can run into the billions of dollars and the project can take years to complete. For example, the demonstrator aircraft for Lockheed Martin Aeronautics' F-35 Lightning II was developed in concept in 1996, but the production model's first test flight was in 2006. The aircraft is scheduled to replace the U.S. Air Force's F-15 aircraft beginning in 2011, but flight testing will be only 56% complete at

that time. The concept development and system development phases for this aircraft alone span 17 years.¹ To control and monitor costs during the life of a project, the DoD often uses a technique referred to as *cost and schedule performance reporting (CSPR)*. A CSPR involves the collection and dissemination of many details about the project and the computation and analysis of variances (differences between actual and budget).

Two variances that are commonly computed are a cost variance and a schedule variance. *Cost variance* is the difference between the *actual* cost of work performed to date (ACWP) and the *budgeted* cost of work performed to date (BCWP). This variance is computed to determine whether the cost of a project is being kept within the budget. When the ACWP exceeds the BCWP, the resulting variance is unfavorable and is commonly referred to as a cost overrun. *Schedule variance* is the difference between the budgeted cost of work *scheduled* to date (BCWS) and the budgeted cost of work *performed* to date (BCWP). This variance is computed to determine whether a project will be completed on time. When the BCWP is less than the BCWS, the resulting variance is unfavorable and is commonly referred to as schedule *slippage*.

The periodic computation and analysis of these variances is important to aid project managers in controlling cost overruns and schedule slippages. A cost and schedule performance report is also useful for nondefense-related projects. For example, a general contractor often accepts a construction project at a fixed price. Unless cost overruns are closely monitored and immediate corrective action taken, a projected profit can turn into an actual loss. Many long-term construction projects often have a penalty clause that requires a contractor to pay a fee when a project is not completed within the promised time frame.

As an example of the computation of a cost variance and a schedule variance, Swaye Bridge Building Company has been constructing a bridge over the Sludge River for more than two years. The bridge was budgeted to cost \$5,000,000 to complete. As of August 31, the bridge is 60% complete and the actual cost of work performed to date is \$3,400,000. The bridge was scheduled to be 70% complete by this date. A cost variance and schedule variance is computed as follows:

$$\text{ACWP} = \$3,400,000$$

$$\text{BCWP} = \$3,000,000 (\$5,000,000 \text{ total budget} \times 60\% \text{ complete})$$

$$\text{BCWS} = \$3,500,000 (\$5,000,000 \text{ total budget} \times 70\% \text{ projected completion stage as of August 31})$$

¹ United States Government Accountability Office, "Joint Strike Fighter," March 2006.

Cost variance:

$$\begin{array}{rcl} & \text{ACWP} & \text{BCWP} \\ \$400,000 & = & (\$3,400,000 - \$3,000,000) \\ \text{Unfavorable} & & \end{array}$$

Schedule variance:

$$\begin{array}{rcl} & \text{BCWP} & \text{BCWS} \\ \$500,000 & = & (\$3,000,000 - \$3,500,000) \\ \text{Unfavorable} & & \end{array}$$

PROCESS COSTING

The design of a cost accumulation system must be compatible with the nature and type of operations performed in a manufacturing company. When the products are manufactured through mass production or a continuous process, a process cost system is usually appropriate. Examples of industries using process cost systems are paper, steel, chemical, and textile. In this section, we introduce process costing and present the basic procedures used in a process cost system.

Process costing is a system of accumulating costs of production by department or cost center. A department is a major functional division in a factory where related manufacturing processes are performed. When two or more processes are performed within a department, it may be desirable to divide the departmental unit further into cost centers. Each process would be designated a cost center and costs would be accumulated by cost centers instead of by departments. For example, the assembly department of an electronics manufacturing company may be divided into the following cost centers: materials setup, wiring, and soldering. Departments or cost centers are responsible for costs incurred within their area; production supervisors must account to middle-level management for the costs incurred by periodically preparing a cost of production report. This report is a detailed record of the unit and cost activities in each department or cost center during a period.

Objectives of Process Costing

A process cost system determines how manufacturing costs incurred during each period will be allocated. The allocation of costs within a department is only an intermediate step; the ultimate goal is to compute total unit costs for

income determination. During a period, some units will be started that will not be completed by the end of that period. Consequently, each department must determine how much of the total costs incurred by the department is attributable to units still in process and how much is attributable to completed units. For example, assume that during January 2,000 units were put into process in Department A. During the month, costs were incurred as follows: direct materials, \$2,000; direct labor, \$1,000; and factory overhead, \$500. At the end of the month, 1,500 units were completed and transferred to Department B.

The objective of a process cost system is to determine how much of the \$2,000 of direct materials, \$1,000 of direct labor, and \$500 of factory overhead costs applies to the 1,500 units completed and transferred to Department B, and how much applies to the 500 units still in process in Department A. A cost of production report is prepared for each department to make this allocation. This report will be presented in detail later in this chapter.

Characteristics of a Process Cost System

Process costing deals with allocating the costs incurred by a department to the units that pass through the department. Unit costs for each department are based on the relationship between costs incurred over a period of time and units completed over the identical period.

A process cost system has the following characteristics:

- Costs are accumulated by department or cost center.
- Each department has its own general ledger Work-in-Process Inventory account. This account is debited with the processing costs incurred by the department and credited with the costs of completed units transferred to another department or to finished goods.
- Equivalent units are used to restate work-in-process inventory in terms of completed units at the end of a period.
- Unit costs are determined by department or cost center for each period.
- Completed units and their corresponding costs are transferred to the next department or to finished goods inventory. By the time units leave the last processing department, total costs for the period have been accumulated and can be used to determine the unit cost of finished goods.
- Total costs and unit costs for each department are periodically aggregated, analyzed, and calculated by use of departmental cost of production reports.

Production by Department

In a process cost system, when units are completed in one department, they are transferred to the next processing department accompanied by their corresponding costs. A completed unit of one department becomes the raw material of the next department until the units reach finished goods. Thus the output of Department 1 becomes the input of Department 2. Department 2 transfers in both the units produced by Department 1 and the Department 1 product costs that belong to these units. When Department 2 completes its processing, it transfers out the units and the costs it inherited from Department 1 plus any costs it incurred while working on the units. Compare the accumulation of costs to a snowball rolling down a hill. As the snowball progresses, it grows larger as more snow sticks to the ball. The costs of a unit grow larger as it progresses along the assembly line from one department to the next.

For example, Cuttup Corporation manufactures scissors and uses three departments to produce one pair. Department 1 molds and attaches the individual blades at an average cost of \$1.00 per unit. The scissors are then moved along a conveyor belt to Department 2, where they are sharpened and polished at an average cost of \$0.50 per unit. The next stop along the conveyor belt is Department 3, where they are painted and packaged at an average cost of \$0.75 per unit. The completed scissors are transferred from Department 3 to finished goods inventory. The total unit cost of one finished scissor is \$2.25, computed as follows:

| Department | Unit Cost Added |
|-----------------------|-----------------|
| 1 | \$1.00 |
| 2 | 0.50 |
| 3 | <u>0.75</u> |
| Total unit cost added | <u>\$2.25</u> |

Figure 21.3 depicts the accumulation of costs from Department 1 through Department 3. Generally, the cost per unit increases as units flow through each

FIGURE 21.3 Accumulation of Costs in a Process Cost System

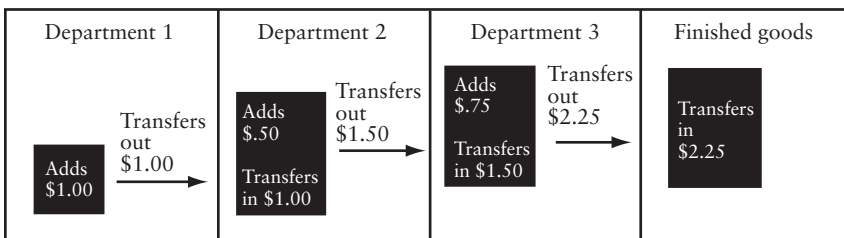

department. The unit cost can decrease when units pass through a department if volume is added to the product. For example, if in Department 8 water is added to a latex paint product, the number of gallons of paint will significantly increase, which would cause the unit cost to decrease.

System Flow

Units and costs flow together through a process cost system. The following equation summarizes the physical flow of units in a department.

| | | | | |
|--|---|---|---|---|
| <p><i>Units to account for:</i></p> <p style="margin-left: 40px;">Beginning units in process</p> <p style="margin-left: 80px;">+</p> <p style="margin-left: 40px;">Units started in process or received from other departments</p> | } | = | { | <p><i>Units accounted for:</i></p> <p>Units transferred out</p> <p style="margin-left: 40px;">+</p> <p>Units completed and still on hand</p> <p style="margin-left: 40px;">+</p> <p>Ending units in process</p> |
|--|---|---|---|---|

This equation illustrates how units received, or started, must be accounted for in a department. A department need not have all components of the equation. If all completed units are transferred out, there will be no “units still on hand.” If all but one of the components are known, the missing component can be computed. The following example illustrates the flow of units within a department.

The Vinjoan Company had in Department A 2,000 units in process at the beginning of the month, placed 6,000 units into process during the month, and had 3,000 units in process at the end of the month. *All* completed units were transferred to Department B. By placing all known figures in the equation, the unknown component (units transferred out) can be found:

| | | | | |
|----------------------------|--------------|---|------------------|-----------------------------------|
| Beginning units in process | 2,000 | | X | Units transferred out |
| + | | | + | |
| Units started in process | <u>6,000</u> | = | <u>3,000</u> | Ending units in process |
| | <u>8,000</u> | = | <u>3,000</u> + X | |
| | <u>5,000</u> | = | X | Units transferred to Department B |

The input and output of costs is reflected in the departmental Work-in-Process Inventory account. The Work-in-Process Inventory account is debited for production costs (direct materials, direct labor, and factory overhead) and

transferred-in costs (direct materials, direct labor, and factory overhead of units completed in a prior department and transferred into the current department). When completed units are transferred out, the Work-in-Process Inventory account is credited for the costs associated with those completed units.

A product may flow through a factory in different ways on route to completion. The most common product flows are sequential, parallel, and selective. The same process cost system can be used for all product flows.

In a *sequential product flow*, the initial raw materials are placed into process in the first department and flow through every department in the factory; additional direct materials may or may not be added in the other departments. All items produced go through the same processes in the same sequence. A flowchart of sequential product flow for the production of pretzels is presented in Figure 21.4.

In a *parallel product flow*, the initial direct material is added during different processes, beginning in different departments, and then joining in a final process or processes. A flowchart of parallel product flow for a television assembly plant is presented in Figure 21.4.

In a *selective product flow*, several products are produced from the same initial raw material. For example, meat-packing industries produce various cuts of meats, skins, and trimmings from an animal carcass. When more than one product results from one production process, the products are called joint products or by-products, depending primarily on their relative sales value. A detailed discussion of joint product and by-product costing will be presented in Chapter 22. A flowchart of selective product flow for a petroleum refinery is presented in Figure 21.4.

Constant-Flow Manufacturing

Constant-flow production, as the name implies, involves a continuous production process. No work orders are necessary because identical (homogeneous) units are processed along an assembly line or conveyor belt in an even flow. The initial raw materials are placed into process in the first department and flow through every department in the factory (a sequential product flow). An example of a constant-flow manufacturing process would be a beer bottling plant. The empty beer bottles are placed on a conveyor belt in the first department and travel, or flow, through the various departments where other production processes add ingredients, caps, labels, and so on. A process cost accumulation system would ideally suit the needs of most constant-flow manufacturers. A company using a constant-flow manufacturing process should significantly reduce inventory costs by developing a just-in-time (JIT) inventory system (also known as ZIPS, zero inventory production system; MAN, materials as needed; and MIPS, minimum in-

FIGURE 21.4 Flowchart Presentation of Product Flows

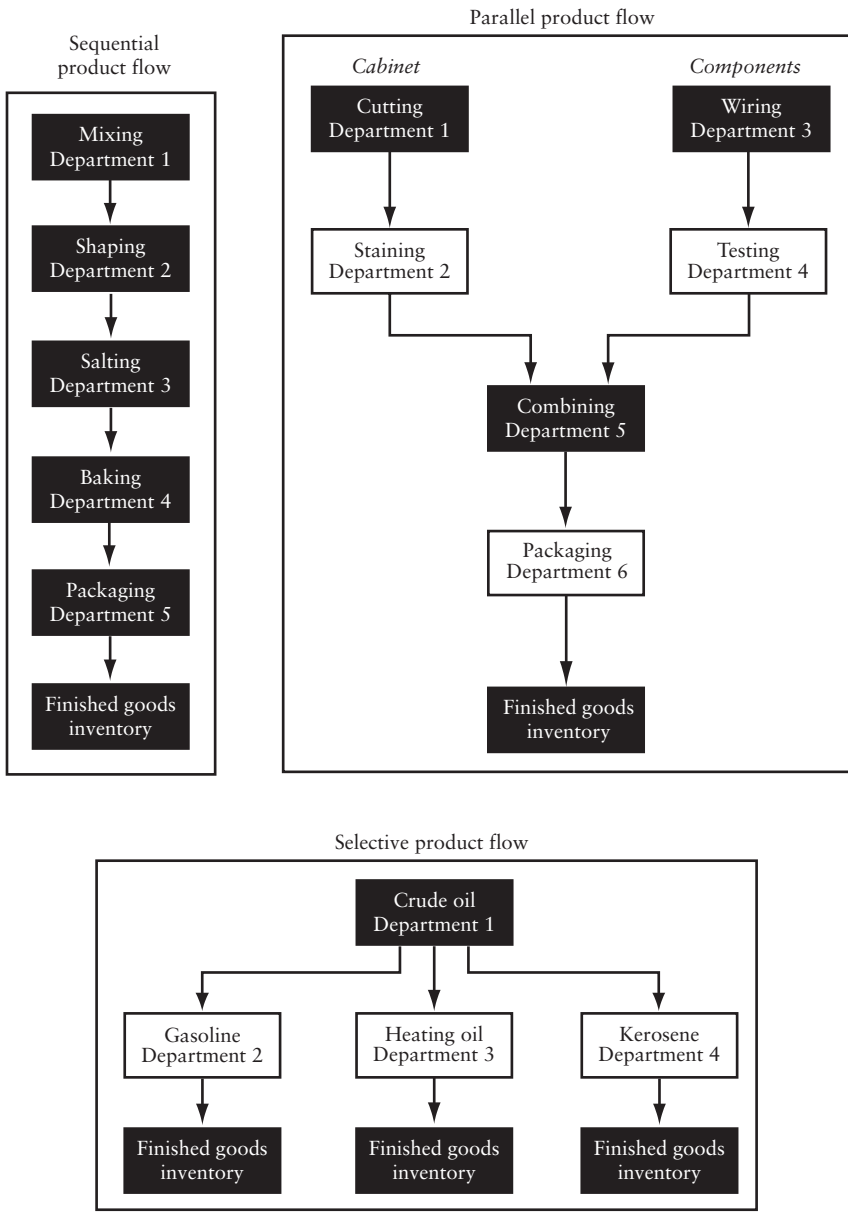

ventory production system). A JIT inventory system provides for little, if any, inventory at all levels of production. Since the manufacturing process results in an even flow of units, a company need only order or produce what is necessary to feed ongoing production. Management knows exactly how many raw materials are needed at any one time to maintain a continuous flow of production, so it can schedule to have the raw materials delivered to the assembly line just in time to meet production requirements. Effective use of JIT procedures should result in significant savings by lowering inventory carrying costs (financing, storage, insurance, etc.). A comprehensive discussion of JIT inventory systems will be presented in Chapter 24.

Procedures: Direct Materials, Direct Labor, and Factory Overhead

The use of a process cost system does not alter the manner of *accumulating* direct materials, direct labor, and factory overhead costs. The normal procedures of cost accounting are used to accumulate the three product cost elements. Process costing is concerned, however, with the *assignment* of these costs to the appropriate *departmental* Work-in-Process Inventory accounts.

A process cost system may accumulate either *normal* absorption costs (actual costs for direct materials, direct labor, and factory overhead applied at a predetermined rate) or *standard* absorption costs (expected costs for direct materials, direct labor, and factory overhead). Examples in this chapter will present process costing using normal absorption costs.

Direct Materials

Direct materials are always added in the first processing department, but they are also usually added in other departments. The journal entry would be the same for adding direct materials in the later processing departments.

The accumulation of direct materials costs is much simpler in a process cost system than in a job order cost system. Process costing generally requires fewer journal entries. The number of departments using direct materials is usually less than the number of jobs requiring direct materials in a job order cost accumulation system. One journal entry at the end of the month for each department is often all that is necessary under process costing.

Direct Labor

The amounts to be charged to each department are determined by the *gross* earnings of the employees assigned to each department. If John Worker works in Department B, his gross salary is charged to Department B. Under a job order cost system, Worker's salary would have to be distributed

among all the jobs he worked on. Process costing reduces the amount of paperwork needed to assign labor costs.

Factory Overhead

In a process cost system, factory overhead costs may be applied using either of the following two methods. The first method, which is also commonly used in job order costing, applies factory overhead to work-in-process inventory at a *predetermined application rate*. This rate is expressed in terms of some common productive activity (e.g., 150% of direct labor costs). The actual factory overhead costs are accumulated in a Factory Overhead Control account. A subsidiary ledger is maintained to record in greater detail the actual factory overhead costs incurred by each department.

A predetermined factory overhead application rate based on normal capacity is appropriate when production volume or factory overhead costs fluctuate substantially from month to month, as it eliminates distortions in monthly unit costs caused by such fluctuations.

The second method charges *actual* factory costs incurred to work-in-process inventory. In the event that production volume and factory overhead costs remain relatively constant from month to month expected capacity is appropriate as the denominator activity level. In a process cost system, where there is continuous production, either method may be used.

Cost of Production Report

The cost of production report is an analysis of the activity in the department or cost center for the period. All costs chargeable to a department or cost center are presented according to cost elements.

In addition to total costs and unit costs, each cost element may be listed separately, either on the report or on a supporting schedule. The amount of detail depends on the planning and control needs of management. The cost of production report is the source for summary journal entries for the period.

A cost of production report for each department may be prepared following a four-step approach. Each step represents a separate schedule and the four schedules together constitute a cost of production report.

Step 1. Account for the physical flow of units (Quantities schedule).

Step 2. Calculate equivalent units of production (Equivalent production schedule).

Step 3. Accumulate the costs, in total and per unit, to be accounted for by a department (Costs to account for schedule).

Step 4. Allocate the accumulated costs to units transferred out or still in process (Costs accounted for schedule).

These schedules are illustrated in the cost of production reports of the King Company, which manufactures Elvis dolls in two departments. Department A is the molding department that makes the body, guitar, sunglasses, clothes, and packaging for the dolls. Department B is the assembly department that puts all the pieces together. The King Company uses a constant-flow manufacturing process. When units from Department A are completed, they are transferred to Department B for further processing. Therefore, the raw materials of Department B are the units received from Department A. The completed units from Department B are then transferred to finished goods inventory. The following data relate to King Company production for January 20XX:

| | Department A | Department B |
|--|--------------|--------------|
| <i>Units:</i> | | |
| Started in process | 60,000 | |
| Received from Department A | | 46,000 |
| Transferred to Department B | 46,000 | |
| Transferred to finished goods inventory | | 40,000 |
| Ending units in process: | | |
| Department A (direct materials 100% complete; direct labor and factory overhead 40% complete) | 14,000 | |
| Department B (direct labor and factory overhead 33 1/3% complete) | | 6,000 |
| <i>Costs:</i> | | |
| Direct materials | \$31,200 | \$0 |
| Direct labor | 36,120 | 35,700 |
| Factory overhead (applied) | 34,572 | 31,920 |

The completed cost of production report of King Company for Department A appears in Table 21.1.

Department A: Cost of Production Report

Step 1: Quantities This schedule accounts for the physical flow of units into and out of departments. The Quantities schedule (Step 1 of Table 21.1) shows that the King Company placed 60,000 units (dolls) into process in Department A during the month. It accounts for the distribution of these units by showing the quantity completed and transferred to Department

TABLE 21.1 King Company: Cost of Production Report, Department A

| (Step 1) Quantities | | | |
|---|---------------------|-------------------------------|------------------------------|
| Units to account for: | | | |
| Units started in process | | | <u>60,000</u> |
| Units accounted for: | | | |
| Units transferred to next department | 46,000 | | |
| Ending units in process | | <u>14,000</u> | |
| (Step 2) Equivalent Production | | | |
| | Direct Materials | Conversion Costs | |
| Units completed and transferred to Department B | 46,000 | 46,000 | |
| Ending units in process: | | | |
| 14,000 x 100% complete | 14,000 | | |
| 14,000 x 40% complete | — | <u>5,600</u> | |
| Total equivalent units | <u>60,000</u> | <u>51,600</u> | |
| (Step 3) Costs to Account For | | | |
| | Total Costs | ÷ Equivalent Production | = Equivalent Unit Cost |
| Costs added by department: | | | |
| Direct materials | \$31,200 | 60,000 | \$0.52 |
| Direct labor | 36,120 | 51,600 | 0.70 |
| Factory overhead | <u>34,572</u> | 51,600 | <u>0.67</u> |
| Total cost to account for | <u>\$101,892</u> | | <u>\$1.89</u> |
| (Step 4) Costs Accounted For | | | |
| Transferred to next department (46,000 × \$1.89) | | \$86,940 | |
| Work-in-process inventory—ending: | | | |
| Direct materials (14,000 × \$0.52) | \$7,280 | | |
| Direct labor (14,000 × 40% × \$0.70) | 3,920 | | |
| Factory overhead (14,000 × 40% × \$0.67) | <u>3,752</u> | <u>14,952</u> | |
| Total costs accounted for | | <u>\$101,892</u> | |

B and the quantity still in process at the end of the month in Department A. Note that the total of *units to account for* (60,000) must always equal the total of *units accounted for* (60,000). Units must be expressed in the

same denomination as the finished product. For example, if raw materials are added in quarts and the finished product is in gallons, the Quantities schedule should state units in terms of gallons.

Step 2: Equivalent Production The concept of equivalent production is basic to process costing. In most cases, not all units are completed during the period. Thus, there are units still in process at varying stages of completion at the end of the period. All units must be expressed in terms of completed units in order to determine unit costs.

Equivalent production equals total units completed plus incomplete units restated in terms of completed units. For example, assume the Little Doll Manufacturing Corporation has the following quantity statistics for a week:

| | |
|------------------------|-----|
| Completed dolls | 500 |
| Dolls still in process | 200 |

(Each doll is 50% complete as to direct materials, direct labor, and factory overhead.)

From these figures, how many dolls did Little produce during the week? If only the completed dolls are considered, then the answer would be 500. However, what about the 200 dolls that are 50% complete? From a production standpoint, the 200 incomplete dolls are equivalent to 100 completed dolls since each doll is 50% complete. Or stated another way, if the 200 half dolls were put together, they would equal 100 whole dolls. Therefore, the correct answer to how many dolls were produced would be 600, calculated as follows:

| | |
|------------------------------------|-------------------|
| Completed dolls | 500 |
| Dolls still in process (200 × 50%) | <u>100</u> |
| Equivalent dolls produced | <u><u>600</u></u> |

Completed units do not create a problem when equivalent production is computed because they are always 100% complete with respect to direct materials, direct labor, and factory overhead. The problem lies in the restatement of incomplete units in terms of completed units. Incomplete units are accounted for in work-in-process inventory until they are completed and transferred to finished goods inventory. Therefore, to compute equivalent production, an analysis must be made of the stage of completion of work-in-process inventory; it must be subdivided into direct materials, direct labor, and factory overhead in order to determine the degree of completion of each component. For example, direct materials may be added at one specific point in production, such as at the beginning or at the end (e.g., packaging) of the process. If direct materials are added at the beginning, all work-in-process units will have complete direct material costs (100% of

direct materials cost). When direct materials are added at the end of a process, work-in-process inventory will not have any direct materials from that department. Direct materials may also be added continuously; in this case the work-in-process inventory will have direct materials equal to the stage of completion of the units in process.

Direct labor and factory overhead costs are usually assumed to be added evenly throughout the process; they will normally be less than 100% complete while they are still in work-in-process inventory. It will be assumed in this chapter, unless otherwise stated, that factory overhead is applied using direct labor as a base. Therefore, the stage of completion for direct labor and factory overhead will be the same and only two equivalent production computations, direct materials and conversion costs (direct labor and factory overhead), will be necessary instead of three. When all three components are at different stages of completion, it is necessary to compute three equivalent productions (direct materials, direct labor, and factory overhead). It is also possible to need only one equivalent production computation if all three components are at the same stage of completion.

Equivalent units for Department A are computed as follows:

| | Direct Materials | Direct Labor | Factory Overhead |
|---|---------------------|-----------------|---------------------|
| Units completed and transferred to Department B | 46,000 | 46,000 | 46,000 |
| <i>Ending units in process:</i> | | | |
| 14,000 × 100% complete | 14,000 | | |
| 14,000 × 40% complete | _____ | 5,600 | 5,600 |
| Total equivalent units | <u>60,000</u> | <u>51,600</u> | <u>51,600</u> |

This schedule presents three separate equivalent unit computations: direct materials, direct labor, and factory overhead. Since the stage of completion for direct labor and factory overhead is the same (i.e., 40%), they may be combined under the heading of conversion costs as follows:

| | Direct Materials | Conversion Costs |
|---|---------------------|---------------------|
| Units completed and transferred to Department B | 46,000 | 46,000 |
| <i>Ending units in process:</i> | | |
| 14,000 × 100% complete | 14,000 | |
| 14,000 × 40% complete | _____ | 5,600 |
| Total equivalent units | <u>60,000</u> | <u>51,600</u> |

The second format (combining of the direct labor and factory overhead columns into one conversion costs column) will be the format used in the remaining equivalent production schedules of this chapter.

Note in the above example that the total equivalent units of production for each cost element was found by adding the ending work-in-process *equivalent* units to the number of completed units. The units in process at the end of the period were restated as *equivalent* units by multiplying units still in process by their average percentage of completion.

In this chapter it is assumed that the units in work-in-process ending inventory are uniformly complete; that is, they are all either 20%, 40%, 75%, and so on, complete. In practice, this is rarely the case. On a typical assembly line the units that are still in process at the end of a period are at *varying stages of completion*. For example, assume an assembly line production process for stereo systems in a department that assembles the internal components in three stages: wiring, speaker attachment, and soldering. At the end of the period, some of the stereos on the assembly line may be in the wiring stage, others in the speaker attachment stage, and still others in the soldering stage. In most cases, the cost of determining each unit's stage of completion would far outweigh the benefits derived, primarily because managerial decision making would be unaffected by the outcome and the change, if any, in the ultimate unit cost would be insignificant. Thus, the average stage of completion of work-in-process ending inventory is usually estimated and does not represent the actual physical stage of completion of any one unit. Instead, it is a rough estimate or average of the composite stage of completion of all units.

The computation of equivalent production (units) is important because equivalent units will be used to compute unit cost in Schedule 3 (Costs to Account For).

Step 3: Costs to Account For This schedule of the cost of production report shows which *costs* were accumulated by the department. Unit costs, broken down by elements, are also presented in this section.

Equivalent unit cost is computed as follows:

$$\text{Equivalent unit cost} = \frac{\text{Costs added during the period}}{\text{Equivalent units}}$$

The numerator (costs added during the period) of the equivalent unit cost equation represents the costs added by the department during the period. The denominator (equivalent units) is the equivalent units taken from the Equivalent Production schedule (Step 2 of Table 21.1). Total equivalent unit cost is the sum of the equivalent unit costs for each element.

The Costs to Account For schedule for King Company, Department A, is presented in Step 3 of Table 21.1. During the month, it cost \$1.89 to produce a completed unit in Department A. It took \$31,200 of direct material costs to complete 60,000 equivalent units, \$36,120 of direct labor costs to complete 51,600 equivalent units, and \$34,572 of factory overhead costs to complete 51,600 equivalent units. Note that in computing equivalent unit cost for direct labor and factory overhead, the number 51,600 was used twice because it is the equivalent production for conversion costs which represents direct labor plus factory overhead.

Step 4: Costs Accounted For This schedule of the cost of production report illustrates the distribution of accumulated costs to units completed and transferred to the next department or to finished goods inventory, units completed and still on hand, and/or units still in process. The total Costs to Account For section must equal the total Costs Accounted For section.

The Costs Accounted For schedule, for King Company, Department A, is presented in Step 4 of Table 21.1. The transferred-out cost is equal to the number of completed units multiplied by the completed unit cost. Additional computations are required to determine ending work-in-process inventory. In Department A, the units still in process have received all their direct materials but only 40% of their conversion costs. The direct labor and factory overhead *unit costs* are expressed in terms of cost per equivalent unit. The 14,000 units still in process must therefore be expressed in terms of completed units or equivalent production. This is accomplished by multiplying the units in process by their degree of completion ($14,000 \times 40\% \text{ completed} = 5,600$). The equivalent production is then multiplied by the unit cost for each cost element.

Department B: Cost of Production Report

The major difference between a cost of production report for the first department (Department A in our example) and that of later departments (Department B in our example) is that subsequent departments have a *transferred-in* section in addition to the items already covered. The output of the first department becomes the input of the subsequent departments.

A cost of production report for Department B (Table 21.2) will be explained with emphasis on the transferred-in section.

Step 1: Quantities Department A started 60,000 units in process and completed and transferred 46,000 to Department B. Of these 46,000 units, 40,000 units were completed and transferred to finished goods inventory, but 6,000 units are still in process at the end of the month. The Quantities schedule for King Company, Department B, is presented in Step 1 of Table 21.2.

TABLE 21.2 King Company: Cost of Production Report, Department B

| (Step 1) Quantities | | | |
|--|---------------------|----------------------------|-------------------------|
| Units to account for: | | | |
| Units received from preceding department | | | <u>46,000</u> |
| Units accounted for: | | | |
| Units transferred to finished goods inventory | 40,000 | | |
| Ending units in process | 6,000 | | <u>46,000</u> |
| (Step 2) Equivalent Production | | | |
| | Conversion Costs | | |
| Units completed and transferred to finished goods inventory | 40,000 | | |
| Ending units in process: 6,000 × 33 1/3% complete | <u>2,000</u> | | |
| Total equivalent units | <u>42,000</u> | | |
| (Step 3) Costs to Account For | | | |
| | Total ÷ Costs | Equivalent = Production | Equivalent Unit Cost |
| Cost from preceding department: | | | |
| Transferred-in (46,000 × \$1.89) ^a | <u>\$86,940</u> | 46,000 | <u>\$1.89</u> |
| Costs added by department: | | | |
| Direct labor | \$35,700 | 42,000 | \$0.85 |
| Factory overhead | <u>31,920</u> | 42,000 | <u>0.76</u> |
| Total costs added | <u>\$67,620</u> | | <u>\$1.61</u> |
| Total costs to account for | <u>\$154,560</u> | | <u>\$3.50</u> |
| (Step 4) Costs Accounted For | | | |
| Transferred to finished goods inventory (40,000 × \$3.50) | | \$140,000 | |
| Work-in-process inventory—ending: | | | |
| Costs from preceding department (6,000 × \$1.89) | \$11,340 | | |
| Direct labor (6,000 × 33 1/3% × \$.85) | 1,700 | | |
| Factory overhead (6,000 × 33 1/3% × \$.76) | <u>1,520</u> | <u>14,560</u> | |
| Total costs accounted for | | <u>\$154,560</u> | |

Note: There is no equivalent production in Department B for direct materials because no direct materials were added by Department B.

^a See Table 21.1, Step 4.

Step 2: Equivalent Production There is nothing different when computing equivalent units for departments after the first because equivalent production is an *output* concept that analyzes only completed units and work-in-process inventory. The Equivalent Production schedule for King Company, Department B is presented in Step 2 of Table 21.2. The transferred-in units to Department B are input for Department B and are received 100% complete with respect to the direct materials and conversion costs that were added in Department A. *Where* the units originated has no impact on the amount produced.

Step 3: Costs to Account For The only difference in this schedule is that subsequent departments have a “cost from preceding department” section that is used to account for the transferred-in costs, units, and unit cost. The “costs added by department” section is computed the same way as in Department A. The Costs to Account For schedule for King Company, Department B is presented in Step 3 of Table 21.2.

Note that the *total* number of units transferred into the department is divided into the *total* transferred-in costs to arrive at the transferred-in *unit cost*. A separate equivalent production calculation is *not* necessary for the units transferred in because the transferred-in units will always be 100% complete when they are transferred out of the preceding department. Remember that a department can transfer out only those units that have been fully completed.

During the month, Department B transferred in 46,000 units from Department A with a total cost of \$86,940. Department B required \$35,700 of direct labor costs and \$31,920 of factory overhead costs to complete 42,000 equivalent units (40,000 units transferred to finished goods inventory + 2,000 (6,000 × 33 1/3% completed) work-in-process ending inventory units).

Department A, which is the first processing department, must account only for the costs it added. Department B must account for the costs it added plus those transferred in from Department A. The transferred-in costs of Department B must be equal to the transferred-out costs of Department A. Note that the transferred-out costs of Department A (\$86,940) become the transferred-in costs of Department B (\$86,940).

Step 4: Costs Accounted For In computing the work-in-process inventory costs for Department B, it is necessary to include the costs from the preceding department. To calculate the cost from the preceding department for ending work-in-process inventory, the number of units in process are multiplied by the transferred-in unit cost. The same computations used in Department A are used to determine direct labor and factory overhead

costs. The Costs Accounted For schedule for King Company, Department B, is presented in Step 4 of Table 21.2. Note that “work-in-process inventory—ending” has costs from the preceding department totaling \$11,340. Ending work-in-process is made up of 6,000 units that are 100% complete as to costs from Department A. The unit costs of goods transferred in from Department A was \$1.89, which, when multiplied by the 6,000 units, equals \$11,340. Department B is building on the work started in Department A. Consider Department A’s costs as the foundation of a house that Department B builds on to complete the rest of the house. The house is still not complete at the end of the month, but it has 100% of its foundation (costs from the preceding department of \$11,340) and is 33 1/3% complete as to the work done by Department B (\$1,700 of direct labor and \$1,520 of factory overhead).

Direct Materials Added after the First Department

Many manufacturing operations require direct materials only in the initial processing department; subsequent departments generally add direct labor and factory overhead (conversion costs) but no additional direct materials. Some manufacturing operations, however, call for the addition of direct materials in subsequent departments. Direct materials added after the first department may have the following effects on units and costs:

- No increase in units but an increase in cost (e.g., adding tires to the production of an automobile).
- Increase in units with no increase in cost (e.g., adding water when producing latex paint if a company is not charged for the cost of the water used).
- Increase in units and in cost (e.g., adding sugar when producing a beverage).

Situation 1: No Increase In Units When the addition of direct materials is made after the first department and the number of units produced does *not* increase, there are no changes in the procedures followed to prepare a cost of production report. Subsequent departments that add direct materials will account for them in the same manner as conversion costs.

Situations 2 and 3: Increase In Units In manufacturing processes that use weight or volume to measure units of production, the addition of direct materials in subsequent departments will usually have the effect of increasing the number of units and possibly total costs. Assume that a product is measured in gallons (volume); Department A places 6,000 gallons into

process and during the month transfers all 6,000 gallons to Department B. If Department B adds 2,000 gallons of another ingredient, it is now responsible for 8,000 gallons (units). Depending on whether the added ingredient has a cost, the total cost and unit cost might also be increased.

Beginning Work-In-Process Inventories

The existence of beginning work-in-process inventories creates a problem in process costing because the following questions must be considered:

- Should a distinction be made between completed units from beginning work-in-process inventory and completed units from the current period?
- Should all the units completed during the current period be included at 100% in equivalent production regardless of the stage of completion of beginning work-in-process inventory?
- Should the costs of beginning work-in-process inventory be added to costs that have been added to production during the current period to arrive at “costs added during the period”?

The answers to these questions depend on the method chosen to account for beginning work-in-process inventory, weighted average costing or first-in, first-out (FIFO) costing.

Under *weighted average costing*, the costs of beginning work-in-process inventory are added to the period's current costs, and this total is divided by equivalent production to arrive at a weighted average equivalent unit cost. Costs associated with the units still in process lose their identity because of the merger. The beginning work-in-process inventory cost is therefore treated as if it were a current period cost. No distinction is made between completed units from beginning work-in-process inventory and completed units from new production. There is only one final cost for all completed units—a weighted average unit cost.

Under *FIFO costing*, the units in the beginning work-in-process inventory are reported separately from units of the current period. Beginning work-in-process units are assumed to be completed first before units started during this period are completed. Costs associated with the beginning units in process inventory are separated from costs of units started and completed during the period. Because of this separation, there are two final equivalent unit cost figures for completed units.

Table 21.3 presents a comparison between weighted average costing and FIFO costing as it affects each section of the cost of production report.

TABLE 21.3 Comparison between Weighted Average Costing and FIFO Costing

| | Weighted Average | FIFO |
|-----------------------------------|---|---|
| Overview | No distinction is made between completed units from beginning work-in-process inventory and completed units from the current period. | Units in the beginning work-in-process inventory are reported separately from units of the current period. |
| <i>Cost of production report:</i> | | |
| 1 Quantities | Same procedure for both methods. | |
| 2 Equivalent Production | All units completed during the period are included as 100% complete, regardless of the stage of completion of beginning work-in-process inventory. | Beginning work-in-process inventory is included in equivalent production only to the extent of the work done to complete these units during the <i>current period</i> . |
| 3 Costs to Account For | Cost of beginning work-in-process inventory is added to costs that have been added to production during the present period to arrive at “costs to account for.” | Beginning work-in-process inventory costs are isolated and do not enter into the computation of equivalent unit costs. |
| 4 Costs Accounted For | Transferred-out costs are determined by multiplying equivalent units by the equivalent unit cost (there is only one total equivalent unit cost). | Transferred-out costs are assumed to come first from beginning work-in process inventory and then from current production (there are two equivalent unit costs—beginning work-in-process inventory and current production). |

BACKFLUSH COSTING

Under a *backflush costing system*, manufacturing costs are charged to cost of goods sold (instead of to work in process) in order to minimize accounting transactions, thereby simplifying the accounting process and making it more efficient and cost effective. Inventory accounts are eliminated unless it is determined at the end of the period that any items are still on hand. When

ending inventories exist, a physical count is made and the inventory is valued at cost. The cost of inventory is set up in the appropriate account (raw materials, work in process, and/or finished goods) and the cost of goods sold account is credited (reduced). Note that in traditional cost systems the work in process inventory is the starting point to accumulate costs to eventually arrive at the cost of goods manufactured and cost of goods sold. In a backflush costing system, specific trigger points (usually at the completion of production or point of sale) are used to work backward to “flush” the system of the costs of production that are charged to cost of goods sold and inventories (if any). In other words, we work backwards by measuring ending inventory at the end of the process and deducting ending inventory from costs of production to arrive at cost of goods manufactured and cost of goods sold. Backflush costing is often used in just-in-time production systems if the manufacturing process is very fast and/or results in nominal or no ending inventories.

BOTTOM LINE

- Cost accumulation is the organized collection and classification of cost data by means of accounting procedures or systems. The most common cost accumulation systems are job order costing and process costing.
- Job order costing is a method of cost accumulation and distribution used by companies that manufacture products according to customer specifications. In a job order cost system, direct materials and direct labor are accumulated by jobs. Factory overhead is accumulated by departments and then applied to jobs. In essence, all factory costs are matched to the products manufactured.
- Direct and indirect materials are obtained from the materials storeroom with an approved materials requisition. Direct materials are charged to specific jobs while indirect materials are charged to a Factory Overhead Control account by department and are applied to individual jobs upon completion, through a factory overhead application rate.
- Labor cost (payroll) is *accumulated* from time cards that mechanically record total hours worked by employees on a daily basis. Labor cost is *distributed* (charged) to the individual jobs in process from labor job tickets that indicate the number of direct labor hours worked on each job or indirect labor hours worked in each department by each employee, on a daily basis. Total labor hours and cost from job tickets should equal total labor hours and cost from time cards.
- Factory overhead incurred is accumulated on a departmental factory overhead cost sheet and applied to particular jobs.

- Operation costing is a form of job order costing in which costs are accumulated by operating or work stations and allocated to individual batches (orders).
- Project costing is a form of job order costing that is commonly used to account for the cost of long-term construction or service contracts. A cost and schedule performance report is usually prepared to control and monitor the costs of a project. A cost variance and a schedule variance are computed and included in most cost and schedule performance reports.
- Process costing is the system of accumulating product costs according to department, cost center, or process. This system is used when finished goods are part of a continuous process and therefore have no individual identity.
- In a process cost system, units and costs flow through departments where they undergo different processes. The product flow may be sequential, parallel, or selective.
- Constant-flow manufacturing involves a continuous production process and is ideally suited for a process cost accumulation system. A just-in-time inventory system may be used in a constant-flow production process to reduce inventory costs.
- All units started by a department or received from another department must be accounted for. The units can be completed and transferred, completed and still on hand, or still in process at the end of the period. As the units pass through each department, they acquire additional costs. One objective of process costing is the allocation of accumulated costs to the units completed and to the end-of-period units still in process.
- Equivalent production is a major concept in process costing. It is rare that all units in production are completed during the period. Some units are usually still in process and at varying stages of completion at the end of the period. To determine unit costs, all units must be expressed in terms of completed units. The degree of completion for each cost element (direct materials, direct labor, and factory overhead) must be determined. The units still in process are multiplied by the degree of completion to arrive at equivalent units. The restated ending work-in-process units plus units completed equals total units of equivalent production. Total costs are divided by total units of equivalent production to determine the unit costs for the period.
- In a process cost system, the cost of production report is the main reporting schedule. All costs chargeable to a department, or cost center, are presented there.

- The four steps or schedules of the cost of production report are quantities, equivalent production, costs to account for, and costs accounted for.
- The *quantities* schedule accounts for the physical flow of units into and out of a department.
- The *equivalent production* schedule accounts for the sum of units still in process at the end of the period restated in terms of completed units plus total units actually completed.
- The *costs to account for* schedule accounts for costs added or received during a period (costs are presented in total and per unit).
- The *costs accounts for* schedule accounts for the distribution of the accumulated costs to units still in process, units completed and still on hand, and units completed and transferred to another department or to finished goods inventory.
- The cost of production report for each department may be presented separately or jointly.
- When direct materials are added after the first department, the following may result: no increase in units but an increase in costs; increase in units with no increase in cost; or increase in both units and cost. When direct materials are added and only costs increase, the Costs to Account For schedule is adjusted to include the cost of the direct materials added. When direct materials added increase units and costs, the Quantities schedule and the Costs to Account For must be adjusted to account for the change.
- Beginning work-in-process inventories may be handled under either the weighted average or first-in, first out (FIFO) costing technique.

APPENDIX: SPOILED UNITS, DEFECTIVE UNITS, SCRAP MATERIAL, AND WASTE MATERIAL IN JOB ORDER AND PROCESS COSTING SYSTEMS

The terms *spoiled units*, *defective units*, *scrap material*, and *waste material* are not synonymous, and they should not be used interchangeably. For this discussion, the following definitions apply:

- ***Spoiled units:*** Units that do not meet production standards and are either sold for their salvage value or discarded. When spoiled units are discovered, they are taken out of production and no further work is performed on them. For example, if a batch of bread is left in the oven too long and burns, it cannot be corrected.

- **Defective units:** Units that do not meet production standards and must be processed further in order to be salable as good units or as irregulars. For example, if a television set does not produce any sound, it can be reworked to correct the problem and sold as a good unit.
- **Scrap material:** Raw materials, left over from the production process, that cannot be put back into production for the same purpose but may be usable for a different purpose or production process or that may be sold to outsiders for a nominal amount. Scrap material such as shavings, filings, and sawdust is similar to a by-product that results from the production of a main product in a joint manufacturing process and has a small sales value in comparison with the main product.
- **Waste materials:** The part of raw materials left over after production that has no further use or resale value. A cost of disposal may be incurred for waste materials.

Accounting for Spoiled Units

A system of accounting for spoilage should be developed for all cost accounting systems. This system should provide management with the information necessary to determine the nature and cause of spoiled units. Spoilage is an important consideration in any production-related planning and control decision. Management must determine the most efficient production process that will keep spoilage to a minimum. Spoilage is typically divided into normal and abnormal spoilage.

Normal Spoilage

Spoilage that results despite efficient production methods is called *normal spoilage*. Normal spoilage costs are considered to be an unavoidable cost of producing good units and are therefore treated as a product cost. For example, the cost of operating a production process that will yield a perfect product 100% of the time may outweigh the benefits. It may be more economical (by employing cheaper and less sophisticated equipment and workers) to accept, for example, a 5% spoilage rate than to plan for perfection. If management developed a production process where a 5% spoilage rate is considered acceptable, then it is expected that an efficient production process would result in no more than 5% normal spoilage. The cost of producing the good units would therefore also include the unavoidable cost of producing the number of spoiled units that are considered normal for the production process.

Abnormal Spoilage

Spoilage in *excess* of what is considered normal for a particular production process is called *abnormal spoilage*. Abnormal spoilage is considered to be controllable by line or production personnel and is usually the result of inefficient operations. Although normal spoilage is acceptable and expected in most production activities and is usually considered a part of production costs, abnormal spoilage is not anticipated and thus is usually not considered a part of the cost of production. Instead, the *total cost* of the abnormal spoiled units should be removed from the Work-in-Process Inventory account and any salvage value should be recorded in a Spoiled Units Inventory account, with the difference between the total cost of abnormal spoilage and the salvage value being charged to a Loss from Abnormal Spoilage account. This account would appear on the income statement as a period cost.

Accounting for Defective Units

The difference between spoiled units and defective units is that defective units are reworked to put them into condition to be sold with good units or to be sold as irregulars, whereas spoiled units are sold (at salvage value) without additional work being performed on them. As with spoiled units, defective units are classified as either normal or abnormal.

Normal Defective Units

The number of defective units in any particular production process that can be expected despite *efficient* operations are called normal defective units. The total costs to rework normal defective units are considered to be an unavoidable cost of producing good units and are therefore treated as a product cost.

Abnormal Defective Units

The number of defective units that exceed what is considered to be normal for an efficient productive operation are called abnormal defective units. The total cost of reworking abnormal defective units should be charged to a Loss from Abnormal Defective Units account instead of the Work-in-Process Inventory account because it is the result of inefficient operations and should not become part of the product cost. The cost of reworking abnormal defective units should be shown on the income statement as a period cost.

Accounting for Scrap Material

A cost accounting system should provide a method of costing and control for scrap as it does for spoilage and defective units. When the amount of scrap produced exceeds the norm, it could be an indication of inefficiency. A predetermined rate for scrap should be prepared as a guide for comparison with the actual scrap that results. If large variances occur, management should find the reason and correct the problem.

Scrap materials have commonly been accounted for in either of the following two ways:

1. Allocated (applied) to all jobs/departments. An estimate of the proceeds from the sale of scrap is considered in the computation of the factory overhead application rate. This method is simple and acceptable when scrap does not result from any particular job and is common to the whole production process.
2. Allocated (applied) to specific jobs/departments. Under this method the estimated proceeds from the sale of scrap are not considered in the computation of the factory overhead application rate. The entry to record the sale of scrap would reduce the work-in-process inventory of the specific job in which the scrap originated.

No entry is normally made on the books when scrap is returned to the materials inventory, only a memorandum as to the type and quantity returned. Only when the dollar amount of scrap is material and there is a significant time lag before it can be sold is an inventory value assigned to the scrap.

Accounting for Waste Material

The cost of disposing of waste materials may be allocated either to all jobs (included in the factory overhead application rate) or to specific jobs (not included in the factory overhead application rate).

Waste exceeding a normal level (based on past experience or engineering specifications) indicates inefficiencies somewhere in the production process and signals management to take corrective action.

Although the cost of disposing of waste materials is usually slight when compared to the total cost of production, in some manufacturing and service operations it may involve significant expenditures. For example, a chemical manufacturer may have toxic waste that requires special packaging before disposal and thus results in an expensive disposal operation. Another example would be the cost of disposing of radioactive waste materials from a nuclear power plant.

The cost of disposing of most types of waste is expected to increase significantly in the near future as existing garbage dumps fill up and more elaborate and expensive forms of disposal must be developed.

Joint Product and By-Product Costing

AGENDA

- Item 1* Define joint costs and distinguish them from common costs.
- Item 2* Discuss the appropriate methods for the allocation of joint costs to joint products.
- Item 3* Define by-products and discuss what may be done with them.
- Item 4* Enumerate the methods for costing by-products.

In many industries, a single production process will yield several different products. For example, petroleum industries produce gasoline, heating oils, and kerosene from the refining of crude oil; meatpacking industries derive various cuts of meats, skins, and trimmings from an animal carcass. When more than one product results from a production process, the products are called *joint products* and *by-products*. Classification depends primarily on their *relative sales value*. Joint product and by-product costing involves the allocation of joint costs to joint products, which is necessary for income and inventory determinations. Costing procedures for joint products and by-products do not constitute a separate cost accumulation system but rather are normally part of a process cost system. In this chapter we present the techniques involved in accounting for joint products and by-products under a process cost system. While the accounting methodologies are explained, they have limited applicability for decision-making purposes. In the final section of this chapter we explain why.

JOINT PRODUCTS

Joint products (which we also refer to as *main products* in this chapter) are individual products, each with significant sales values, that are produced simultaneously from the same raw material and/or manufacturing process. For example, soybean oil and soybean meal are joint products that result from the processing of soybeans. Joint products also occur in the meat-

packing industry and in many natural-resource refining industries. The basic characteristics of joint products are:

- Joint products have a physical relationship that requires simultaneous common processing. Processing of one of the joint products results in the processing of all the other joint products at the same time. When additional quantities of one joint product are produced, the quantities of the other joint products will increase proportionately.
- Manufacturing of joint products always has a split-off point at which separate products emerge, to be sold as is or processed further. Costs incurred after the split-off point do not generally cause allocation problems because they can be identified with the specific products.
- None of the joint products is significantly greater in value than other joint products. This is the characteristic that distinguishes joint products from by-products.

Joint Costs and the Split-Off Point

Joint costs should not be thought of as a new type of product cost in that they consist of direct materials, direct labor, and factory overhead. A major difficulty inherent in joint costs is that they are *indivisible*; that is, joint costs are not specifically identifiable with any of the products being simultaneously produced. For example, the costs incurred by a refining company to locate, mine, and process ore are joint costs that must be allocated to the iron, zinc, or lead that are later extracted from the ore. Since joint costs cannot be specifically identified with iron, zinc, or lead, they must be allocated to each joint product.

Joint costs are sometimes confused with common costs. Common costs are those incurred to produce products simultaneously, but each of the products could have been produced separately. Therefore, common costs are *divisible* and can be specifically traced to each of the products produced, whereas joint costs cannot. For example, the cost of lumber for a furniture manufacturer is a common cost that can be directly traced to the various products produced. It is interesting to note that the cost of trees for a sawmill is a joint cost because the various types of products that trees yield cannot be varied.

Additional processing costs (sometimes called *separable costs*) are those incurred by individual products *after* they have emerged (called the *split-off point*) from the common raw material and/or the common manufacturing process. Additional processing costs simply consist of the additional direct materials, direct labor, and factory overhead incurred for the identifiable products after the split-off point in contrast with the joint costs, which are incurred for the benefit of all products prior to the split-off point.

FIGURE 22.1 Illustration of a Joint Manufacturing Process for a Meat Processor

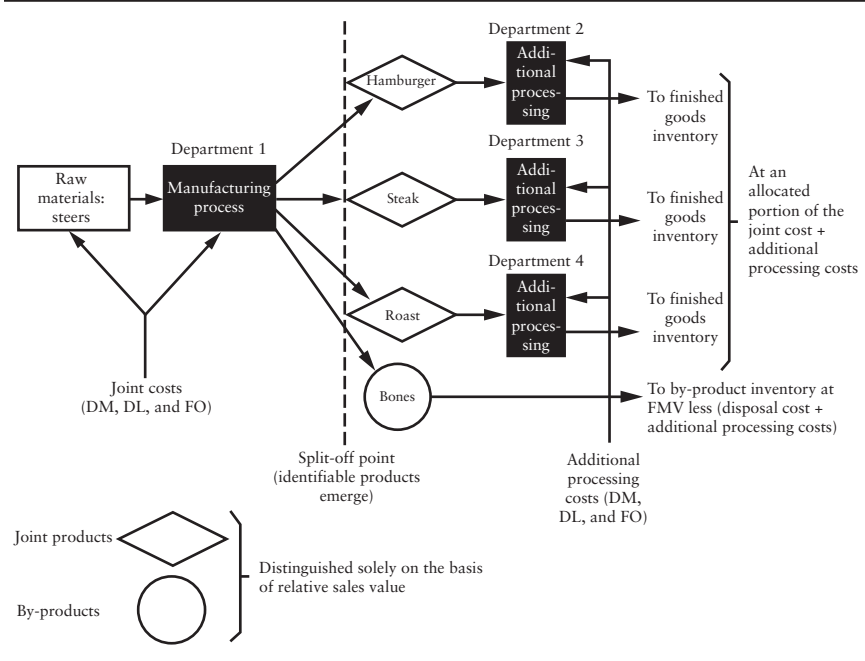

Figure 22.1 is an illustration of a joint manufacturing process for a meat processor.

Accounting for Joint Products

Joint product costs must be allocated to individual products in order to determine the ending work-in-process and finished goods inventories, cost of goods manufactured and sold, and gross profit. As discussed previously, specific identification is not possible. Therefore, an appropriate method must be used to allocate a portion of the joint costs to individual joint products. Three methods are commonly used to allocate joint costs. The *physical output method* is based on volume, and the other two on market value—the *market value at split-off method* and the *net realizable value method*.

The following example will illustrate joint product costing using the three methods. Fillerup Oil Refinery Company produces gasoline, heating oil, and jet fuel from refining crude oil. The initial refining of 820,000 gallons is begun in Department 1. Three partially completed products emerge (split-off point) from Department 1. Each product is then sent to the following departments to complete their processing:

| Department | Final Product | Gallons Received |
|------------|---------------|------------------|
| 2 | Gasoline | 280,000 |
| 3 | Heating oil | 340,000 |
| 4 | Jet fuel | <u>200,000</u> |
| | Total | <u>820,000</u> |

Figure 22.2 illustrates the production flow for Fillerup Company. The following additional statistics relate to Fillerup Company.

| Department | Production Costs | Total Disposal Costs | Market Value at Split-Off | Final Market Value after Further Processing |
|------------|------------------|----------------------|---------------------------|---|
| 1 | \$164,000 | — | — | — |
| 2 | 50,000 | \$4,000 | \$0.80 | \$1.15 |
| 3 | 30,000 | 1,000 | 0.70 | 1.00 |
| 4 | <u>35,000</u> | <u>5,000</u> | 0.95 | 1.40 |
| Total | <u>\$279,000</u> | <u>\$10,000</u> | | |

The Department 1 costs of \$164,000 are the joint cost because they occur before the split-off point and therefore relate to all three products. The production costs for Department 2 (\$50,000), Department 3 (\$30,000), and Department 4 (\$35,000) are considered additional processing costs because they occur after the split-off point.

FIGURE 22.2 Production Flow for Fillerup Company

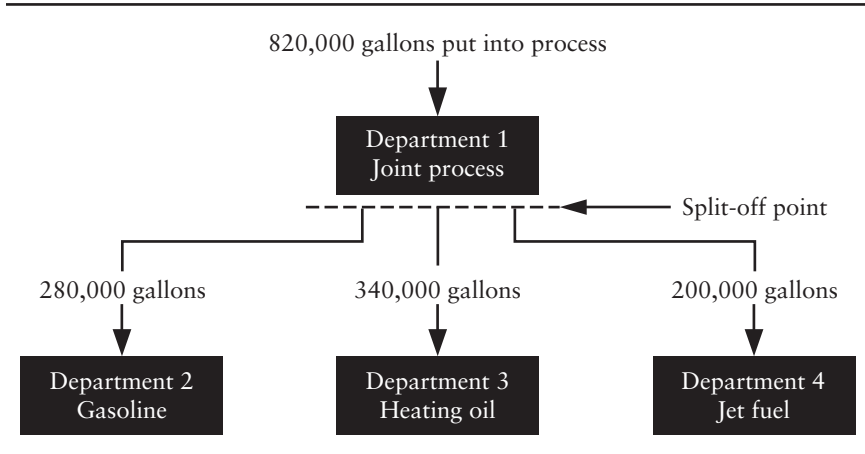

Physical Output Method

Under the physical output method, the quantity of output is the basis for allocating joint costs. The quantity of output is expressed in units, which may be tons, gallons, or any other appropriate measurement. The quantity of output for all the joint products must be stated in the same scale. In the unlikely event that the measurement basis (scale) varies from product to product, a common denominator has to be found.

Joint cost is allocated to each product by a ratio of output per product over total joint product output multiplied by total joint cost. The formula is

$$\text{Joint cost allocation to each product} = \frac{\text{Output per product}}{\text{Total joint products}} \times \text{Joint cost}$$

Using the information from Fillerup Company, the following *joint cost* allocation is made:

| | | | | | |
|------------------|---------------------------|---|-----------|---|------------------|
| Gasoline | $\frac{280,000}{820,000}$ | × | \$164,000 | = | \$56,000 |
| Heating oil | $\frac{340,000}{820,000}$ | × | \$164,000 | = | 68,000 |
| Jet fuel | $\frac{200,000}{820,000}$ | × | \$164,000 | = | <u>40,000</u> |
| Total joint cost | | | | | <u>\$164,000</u> |

The *total* production costs of a product are computed as follows:

| Product | Allocated Joint Cost (Department 1) | + | Additional Processing Costs (Departments 2, 3, and 4) | = | Total Production Costs |
|-------------|---|---|---|---|------------------------------|
| Gasoline | \$56,000 | | \$50,000 | | \$106,000 |
| Heating oil | 68,000 | | 30,000 | | 98,000 |
| Jet fuel | <u>40,000</u> | | <u>35,000</u> | | <u>75,000</u> |
| Total | <u>\$164,000</u> | | <u>\$115,000</u> | | <u>\$279,000</u> |

The primary assumption of this method is that all products produced by a common process should be charged a proportionate share of the total joint cost based on the number of units produced. It is assumed that the products are homogeneous and one product does not require more or less effort (cost) than any other product in the group. The most appealing characteristic of this method is its simplicity, not its accuracy.

The major drawback of allocating joint costs on the basis of quantity produced is that the revenue-producing ability of the product is not considered. For example, if the parts of a steer were allocated joint cost solely on the basis of weight, the parts that are sold as steak would have the same unit cost as the parts that are sold for chopped meat.

Market Values at Split-Off Method

Advocates of this method argue that a direct relationship exists between *cost* and selling price. They contend that selling prices of products are determined primarily by the costs involved in producing the products. Therefore, joint product costs should be allocated on the basis of the market value of the individual products. This is the most popular allocation method.

When the market value is known at the split-off point, the total joint cost is allocated among the joint products by dividing the total market value of each joint product by the total market value of all joint products to arrive at a ratio of individual market values to total market values. This ratio is then multiplied by the total joint costs to arrive at the joint cost allocation to each product as shown below.

$$\text{Joint cost allocation to each product} = \frac{\text{Total market value of each product}}{\text{Total market value of all products}} \times \text{Joint costs}$$

In the above formula,

- The total market value of *each* product is the product of units produced of *each* product and the unit market value of *each* product.
- The total market value of *all* products is the sum of all the individual products' market values.

On the basis of the information from Fillerup Company, the following joint costs can be allocated. First the total market value of each joint product at the split-off point is computed.

| Product | Units Produced of Each Product | × | Unit Market Value of Each Product at Split-Off | = | Total Market Value of Each Product at Split-Off |
|------------------------------------|--------------------------------|---|--|---|---|
| Gasoline | 280,000 | | \$0.80 | | \$224,000 |
| Heating oil | 340,000 | | 0.70 | | 238,000 |
| Jet fuel | 200,000 | | 0.95 | | <u>190,000</u> |
| Total market value of all products | | | | | <u>\$652,000</u> |

Second, the formula is applied to determine the amount of joint cost to be allocated to each joint product:

| Product | Ratio | × | Joint Cost | = | Allocation of Joint Cost |
|-------------|-------------------------------|---|------------|---|--------------------------|
| Gasoline | $\frac{\$224,000}{\$652,000}$ | × | \$164,000 | = | \$56,344 |
| Heating oil | $\frac{\$238,000}{\$652,000}$ | × | \$164,000 | = | 59,865 |
| Jet fuel | $\frac{\$190,000}{\$652,000}$ | × | \$164,000 | = | <u>47,791</u> |
| Total | | | | | <u>\$164,000</u> |

Finally, the total cost of producing the joint products is the sum of the additional processing costs and the allocated joint costs.¹

| Product | Allocated Joint Cost (Department 1) | + | Additional Processing Costs (Departments 2, 3, and 4) | = | Total Production Costs |
|-------------|---|---|---|---|------------------------------|
| Gasoline | \$56,344 | | \$50,000 | | \$106,344 |
| Heating oil | 59,865 | | 30,000 | | 89,865 |
| Jet fuel | <u>47,791</u> | | <u>35,000</u> | | <u>82,791</u> |
| Total | <u>\$164,000</u> | | <u>\$115,000</u> | | <u>\$279,000</u> |

Net Realizable Value Method

When the market value is known at the split-off point, it should be used to allocate the joint costs, as illustrated in the previous example. However, the market value or replacement cost of a joint product may not be readily determinable at the split-off point, especially if additional processing is required in order to manufacture the product. When this situation exists, the next best approach is to allocate joint costs using the net realizable value method. Under this method, any estimated additional processing and disposal costs are deducted from the final sales value in an attempt to approximate a hypothetical market value at the split-off point. The joint cost allocation to each product is computed as follows: The total hypothetical market value of each joint product is divided by the total hypothetical market value of all joint products to determine the ratio of individual market value to total market value. This ratio is then multiplied by the joint cost applicable to the fully completed units (from a cost of production report) to allocate the joint cost to the individual joint products. More specifically, the formula is:

¹ Disposal costs are selling expenses, not production costs.

Joint cost allocation to *each* product

$$= \frac{\text{Total hypothetical market value of each product}}{\text{Total hypothetical market value of all products}} \times \text{Joint costs}$$

In the above formula,

- Total hypothetical market value of *each* product = (Units produced of *each* product × Final market value of *each* product) – Additional processing costs and disposal costs of *each* product.
- Total hypothetical value of *all* products = Sum of all the individual products' hypothetical market values.

Using the information from Fillerup Company, the following joint cost allocation is made:

| Product | Ratio | × | Joint Cost | = | Allocation of Joint Cost |
|-------------|-------------------------------|---|------------|---|--------------------------|
| Gasoline | $\frac{\$268,000}{\$817,000}$ | × | \$164,000 | | \$53,797 |
| Heating oil | $\frac{\$309,000}{\$817,000}$ | × | \$164,000 | | 62,027 |
| Jet fuel | $\frac{\$240,000}{\$817,000}$ | × | \$164,000 | | <u>48,176</u> |
| Total | | | | | <u>\$164,000</u> |

The following supporting computations are necessary:

| (1) | (2) | (3) | (4) | (5) | (6) |
|-------------|----------------|-----------------------------|------------------------------------|--|---|
| Product | Units Produced | Final Market Value per Unit | Total Final Market Value (2) × (3) | Total Additional Processing and Disposal Costs | Total Hypothetical Market Value of Each Joint Product (4)–(6) |
| Gasoline | 280,000 | \$1.15 | \$322,000 | \$54,000 ^a | \$268,000 |
| Heating oil | 340,000 | 1.00 | 340,000 | 31,000 ^b | 309,000 |
| Jet fuel | 200,000 | 1.40 | 280,000 | 40,000 ^c | <u>40,000</u> |
| Total | | | | | <u>\$817,000</u> |

^a \$50,000 + \$4,000

^b \$30,000 + \$1,000

^c \$35,000 + \$5,000

To arrive at the total cost of producing the products, only the additional processing costs are added to the joint costs, as follows:

| Product | Allocated Joint Cost (Department 1) | + | Additional Processing Costs (Departments 2, 3, and 4) | Total Production Costs |
|-------------|---|---|---|------------------------------|
| Gasoline | 53,797 | | \$50,000 | \$103,797 |
| Heating oil | 62,027 | | 30,000 | 92,027 |
| Jet fuel | <u>48,176</u> | | <u>35,000</u> | <u>83,176</u> |
| Total | <u>\$164,000</u> | | <u>\$115,000</u> | <u>\$279,000</u> |

The major advantage of the market value method and the net realizable value method of allocating joint cost to joint products is that they are based on the revenue-producing ability of the individual products. Thus, when a common raw material is split off, the emerging joint products that yield the highest revenue will be allocated the largest portion of the joint costs. Under these methods, a change in market value of any of the products will cause a change in joint costs assigned to all joint products even though no change in production has taken place. This fluctuation of cost allocation ratios as a result of changes in market values, along with the fact that it inherently assumes that no profit is generated by processing further, are seen as the major criticisms of this method.

Note that in all the methods the total joint cost (\$164,000) and the total production cost (\$279,000) are the same. The difference between the methods is how these costs are allocated to the individual products.

BY-PRODUCTS

By-products are those products of limited sales value produced simultaneously with products of greater sales value, known as main or joint products. Main products are generally produced in much greater quantity than by-products. By-products are an incidental result of producing main products. By-products may result from the cleansing of main products or the preparing of raw materials before they are used to manufacture main products, or they may be the leftovers after main products are processed.

After they have emerged along with joint products at the split-off point, by-products either may be sold in the same form as originally produced or they may undergo further processing before sale.

Occasionally there is a problem of whether to classify a product as a by-product or as scrap. The basic difference between the two is that by-products have a greater sales value than scrap. Also, scrap is generally sold

immediately, whereas by-products quite often must undergo further processing after the split-off point in order to be salable.

The classification of products as joint products, by-products, or scrap may change as new uses of the products are discovered or old ones abandoned. Because of technological discoveries, a product may change from a by-product to a joint product. For example, in the petroleum industry, gasoline was originally a by-product of the main product, kerosene. After the invention of the automobile, however, gasoline became the main product and kerosene the by-product. In many cases, uses have even been found for products formerly considered waste. For example, many sewage plants have found ways to convert their waste into fertilizer.

Product markets change frequently; thus a product that may have a relatively small sales value today may have a significant sales value tomorrow. Therefore, management should frequently examine product classifications and make reclassifications when necessary.

Accounting for By-Products

As already stated, by-products, like joint products, are produced from a common raw material and/or a common manufacturing process. Joint costs are not directly traceable to either main products or by-products. Since by-products are generally of secondary importance in production, cost allocation methods differ from those used for joint products. The methods of costing by-products fall into two categories: category 1, in which by-products are recognized when sold, and category 2, in which by-products are recognized when produced.

Category 1: By-Products Recognized When Sold

By-products are considered of minor importance and therefore no income is recorded from them until they are sold. Net by-product income equals actual sales revenue less any actual additional processing costs and marketing and administrative expenses. Net by-product income may be shown on the income statement as:

- An addition to income, as part of either “Other Sales” (at the top of the income statement) or “Other Income” (at the bottom of the income statement).
- A deduction from cost of goods sold of the main product.

For example, assume the following facts for Splinter Sawmill Company: Splinter’s main product is 8-foot-long, 2- by 4-inch-wide strips of wood,

which are cut in Department 1 and require no additional processing. The sawdust accumulated from the cutting process in Department 1 is transferred to Department 2, where it is packaged for sale as a by-product. Cost and revenue data and the computation of the net income are presented in Table 22.1.

Category 2: By-products Recognized When Produced

Management would consider using the net realizable value method when the net by-product income is significant and therefore by-products are considered important. The expected value of the *by-products* produced is shown on the income statement as a deduction from the total production costs of the *main product* produced. The unit cost of the main product is therefore reduced by the expected value of the by-product produced. Under the net realizable value method, the expected sales value of the by-product produced is reduced by the expected additional processing costs and marketing and administrative expenses. The resulting net realizable value of the by-product is deducted from *total* production costs of the main product.

The following example of the net realizable value method is based on the information given for Splinter Sawmill Company:

Net realizable value method:

| | | |
|--|--------------|----------------|
| Sales (main products) | | \$37,500 |
| Cost of main products sold: | | |
| Total production costs | \$31,500 | |
| Value of by-product produced [$\$2,520 - (\$100 + \$500)$] | <u>1,920</u> | |
| Net production costs | \$29,580 | |
| Less ending inventory ($3,000 \times \$1.643$) | <u>4,929</u> | <u>24,651</u> |
| Gross profit | | \$12,849 |
| Marketing and administrative expenses of main product | | <u>3,250</u> |
| Net income | | <u>\$9,599</u> |

In the above computations, the \$2,520 (expected sales value) is found by multiplying the 2,800 by-product units produced by \$0.90, the by-product sales price per unit. The \$1.643 per unit in computing the ending inventory is found by dividing the net production costs of \$29,580 by the 18,000 units of the main product produced.

TABLE 22.1 Cost and Revenue Data—Splinter Sawmill Company

| | | |
|---|--------------|----------------|
| <i>Total production costs:</i> | | |
| Department 1 | | \$31,500 |
| Department 2 (\$60 direct materials, \$30 direct labor, and \$10 factory overhead) | | 100 |
| <i>Units of the main product:</i> | | |
| Produced | | 18,000 |
| Sold | | 15,000 |
| Ending inventory | | 3,000 |
| <i>Units of the by-product:</i> | | |
| Produced | | 2,800 |
| Sold | | 2,500 |
| Ending inventory | | 300 |
| <i>Estimated marketing and administrative expenses:</i> | | |
| Main product | | \$3,250 |
| By-product | | 500 |
| <i>Actual sales revenue:</i> | | |
| Main products (15,000 units @ \$2.50 per unit) | | \$37,500 |
| By-product (2,500 units @ \$0.90 per unit) | | 2,250 |
| Expected gross profit for by-products | | 40% |
| Ignore income taxes | | |
| 1 Net by-product income treated as other income: | | |
| Sales (main product) | | \$37,500 |
| <i>Cost of main product sold:</i> | | |
| Total production costs | \$31,500 | |
| Less ending inventory (3,000 × \$1.75 ^a) | <u>5,250</u> | |
| Total cost of main product sold | | <u>26,250</u> |
| Gross profit | | \$11,250 |
| Marketing and administrative expenses of main product | | <u>3,250</u> |
| Income from operations | | \$8,000 |
| <i>Other income:</i> | | |
| Net by-product income [\$2,250 – (\$100 + \$500)] | | <u>1,650</u> |
| Net income | | <u>\$9,650</u> |
| 2 Net by-product income treated as a deduction from cost of goods sold of the main product: | | |
| Sales (main product) | | \$37,500 |
| <i>Cost of main product sold:</i> | | |
| Total production costs | \$31,500 | |
| Less ending inventory (see above) | <u>5,250</u> | |
| Total cost of main product sold | \$26,250 | |
| Less net by-product income (see above) | <u>1,650</u> | <u>24,600</u> |
| Gross profit | | \$12,900 |
| Marketing and administrative expenses of main product | | <u>3,250</u> |
| Net income | | <u>\$9,650</u> |

^a \$31,500/18,000 = \$1.75.

EFFECTS OF JOINT COST ALLOCATION UPON DECISION MAKING

While we have described the practice for allocation for joint products, it is important to note that they should not be used by management for decision-making purposes. Decision making generally involves output decisions, further processing decisions, and pricing decisions. In each of these, joint cost allocation is not relevant information and may prove to be counterproductive. The allocation of joint costs is performed mainly for purposes of product costing and should not influence management in its planning and control of joint costs. However, the allocation of total production costs to joint products and by-products is very important because it will determine the valuation of inventories, which directly impacts the bottom line.

The very nature of joint products and by-products limits the flexibility of decisions. The physical characteristics of main products require that all the products in the group be produced. When the products manufactured are proportionately fixed in quantities relative to each other, a decision to produce more or less of one product will result in proportionally more or less of the other products. Therefore, more useful information is obtained by comparing total input costs with the potential revenue generated from total output. Individual profit for each product is of little significance in production decisions regarding joint product and by-product production.

When the products can be produced in alternative ratios or "mixes," the decision is based on which mix obtains the most profit. In this situation, income increments are analyzed. Total cost variation under each alternative can be calculated and compared with the resultant total revenue. Although individual product cost cannot be specifically measured, total costs and total revenue can.

Neither are joint cost allocations useful in price determinations. All products are expected to be sold; thus individual product pricing is aimed at selling all the joint products in the same proportion as that in which they are manufactured. This circular reasoning occurs because in certain methods selling price determines joint cost allocation. That is, selling prices are used to determine costs and costs are then used to determine selling prices.

Total joint cost allocation has no influence on the decision whether to sell at the split-off point or manufacture a product further. A decision to process further depends on whether the incremental revenue is greater than the incremental cost. Management decisions should therefore be based on opportunity costs rather than on the allocation of past or sunk joint costs.

The decision whether to sell a joint product or a by-product at the split-off point or process it further is not driven by the accounting treatment. If external markets exist for semifinished products, the manufac-

turer must decide which products are more profitable to sell at the split-off point and which should be processed further before sale. Recall that the split-off point is that point where identifiable products emerge from the joint process.

The costs incurred before the split-off point (i.e., joint costs) are irrelevant in determining whether the products should be processed further. By the time the joint products have reached the split-off point, the joint costs have already been incurred. In the context of this type of problem-solving situation, joint costs are sunk costs. They are neither future costs nor costs that will differ whether it is decided to sell one or more of the joint products at the split-off point or after additional processing. Joint costs need to be considered in determining whether a joint process should be initially undertaken. Incremental analysis provides the basis for solving the sell-or-process-further problem. If the additional revenue earned by processing further is greater than the additional cost, the product should be processed further; however, if the additional cost of processing further is greater than the additional revenue earned, the product should be sold at the split-off point.

BOTTOM LINE

- Many manufacturing processes produce different products from initial raw materials and/or a common manufacturing process. Depending on their relative sales value, the products are either joint products or by-products. Joint products and by-products by their inherent nature contain an element called joint costs. Joint costs are made up of direct materials, direct labor, and factory overhead.
- Joint costs are the costs incurred up to the point in a given process where individual products can be identified. The point of production at which separate products are identifiable is known as the split-off point. Joint costs incurred up to split-off cannot be identified with specific products.
- A major difficulty inherent in joint costs is that they are indivisible; joint costs are not specifically identifiable with any of the products being simultaneously produced.
- Joint products are individual products, each of significant sales value. The manufacture of joint products occurs in the meatpacking industry, in natural-resource refining industries, and in those industries where raw materials must be graded before processing.
- Additional processing costs are those incurred as identifiable after the split-off point. Like joint cost, they are made up of direct materials, direct labor, and factory overhead. No allocation of separable costs is

necessary since they can be directly traced to individual joint products and by-products. The final product cost of joint products includes some allocated portion of joint costs and any necessary additional processing costs. The final product cost of the by-product may be allocated a portion of joint costs (depending on the technique used) plus additional processing costs, if necessary.

- Because of the importance of each joint product, individual product costs for both income determination and inventory valuation are necessary. Joint product costs should be allocated to each individual joint product.
- Three methods for the allocation of joint costs are commonly used: physical output, market value at split-off, and net realizable value.
- By-products are products of limited sales value produced simultaneously with a product of greater value known as the main product. By-products are an incidental result of producing the main product. By-products may be sold in the same form as originally produced, or they may undergo further processing before sale. Because by-products are generally of secondary importance, cost allocation procedures differ from those used for joint products.
- Current classifications of products as joint products or scrap are not permanent. Depending on market values and technological changes, products can shift very readily from one classification to another.
- Allocation of joint costs is used primarily for product costing for financial reporting purposes and should not be used in managerial decision making.

Master Budget

AGENDA

- Item 1* Explain the relation among the various sales, production, and expense budgets with the master budget.
- Item 2* Identify the different types of budgeting systems.
- Item 3* Identify the link among the production budget and the direct labor, direct materials, direct purchases, and the ending inventories budgets.
- Item 4* Describe the linkages among the cash receipts and cash disbursements schedules and the cash budget.

A budget is a quantitative expression of management objectives and a means of monitoring progress toward achievement of those objectives. An effective budget must be aimed at the strategic targets of the company, as well as well-coordinated with the company's management and accounting systems. In addition, an effective budget process includes a procedure for monitoring and making adjustments if necessary. For example, there must be a chart of accounts and a sound organization chart, which shows the responsibilities of each executive for whom a budget is justified. Another important requirement for a good budget is a standard cost system.

Standard costs, the subject of the previous chapter, are the costs per unit that are expected to be achieved in a particular production process, whereas budgeted costs are the total costs expected to be incurred. A standard cost per unit may be likened to a single brick, whereas a budget represents an entire house.

For a budget to be effective, company officials must fully understand their responsibilities in making the budget work, whether they participate in planning it or not. Budgets can cover different periods of time, depending on the type of budget. For example, operations budgets normally cover a period of 1 year or less (short term). Budgets for plant or product changes

can cover a period of 2 to 10 years (long term). Operations budgets are frequently broken down by months for the first quarter and in total for the next three quarters. At the end of the first quarter, the budgets for the following three quarters are updated on the basis of new information. Many companies now use continuous (moving or rolling/cycle) budgets by which 12-month data is always provided. At the end of each month, that month is dropped and a new month is added at the end so that a 12-month budget is always available.

Someone on the CFO's or controller's staff is usually responsible for coordinating all the parts of the budget. The various components, such as sales by product and by territory and production by product and by month, are prepared by line management. In most large companies, the budget director reports directly to the budget committee, which usually consists of the president, the vice presidents in charge of marketing, production, and engineering, the CFO or treasurer, and the controller.

The procedural aspects of budgeting, such as what is to be budgeted, when, and by whom, are the responsibility of the budget director, subject to approval by the budget committee. A key element of budgeting and planning to achieve the company's strategic objectives is the master budget. The *master budget* is a summary of the planned activities of all of the units of the company, including production, sales, distribution, and finance. In other words, as shown in Figure 23.1, the master budget is a device used to bring together all of the relevant pieces in the budgeting and planning process for the operation of the company. Along with the company's strategic and long-term plan, the master budget is a useful device for planning and measuring progress toward the company's goals.

A budget manual is usually prepared giving the due date for each segment of the master budget, assigning responsibility for its preparation, and describing the forms and related budgeting policies and procedures.

The step-by-step preparation of the various segments of the master budget demands careful considerations by management with many key decisions concerning pricing, product lines, production scheduling, capital expenditures, research and development, and other items. The initial draft of a budget and its critical budget review always prompt many questions and managerial decisions leading to further drafts before the final budget is approved.

In actual practice, there could be many additional analyses supporting the budgets shown. Figure 23.1 is a diagram of the various schedules that make up a master budget. In this chapter, we discuss the master budget, its budgeted schedules, and budgeted summaries.

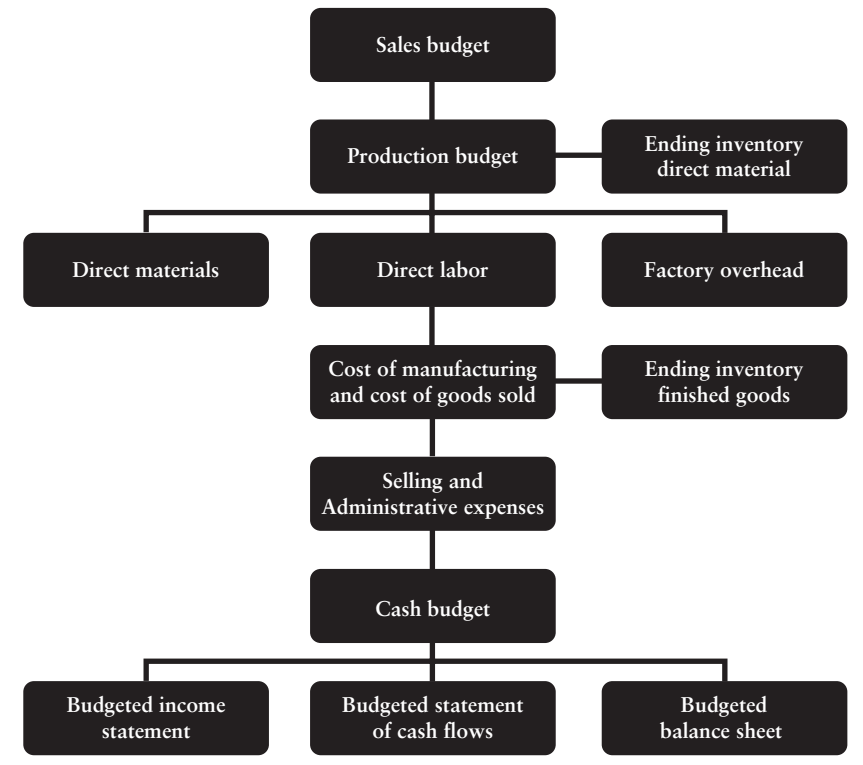
FIGURE 23.1 The Schedules That Comprise the Master Budget

CONVENTIONAL MASTER BUDGET SYSTEM

A *conventional master budget system* is essentially an incremental budget system. It is based, to a large degree, on the prior period's master budget. The actual results that were achieved for the prior period plus expectations for the upcoming period determine whether each item in the master budget is to be increased or decreased. In a conventional master budget, the emphasis is on the cost of specific inputs as management budgets the cost of operating individual responsibility centers.

The items already included in the master budget (from decisions made in prior periods) require no justification of their ongoing needs. Items to be included for the first time in the master budget, however, require supporting documentation and upper-level management approval.

Zero-Based Budget System

One approach to a budget is to use zero-based budgeting. In a *zero-based budget (ZBB)* system, a responsibility center manager must justify each planned activity and its estimated total cost as if it were being initiated for the first time. This is in contrast to a system whereby only costs in excess of the previous planning period's costs must be justified.

In ZBB, the planners begin with a listing of all the different activities or programs of a responsibility center, referred to as a *decision package*. Each decision package is assigned a ranking based on its perceived importance to the responsibility center manager. The rankings should ideally be based on the goals and objectives of the decision packages relative to the goals and objectives of the organization. All responsibility center budget requests ranked by decision packages are submitted to upper-level management. A budget committee is appointed to give careful consideration to each budget request and make revisions or deletions as necessary in light of the overall needs of the organization. Budget allocations to each responsibility center will be based on the central ranking system of the budget committee and the amount of available funds. The ZBB process is repeated every budget period.

Program Planning and Budget System

A *program planning and budget system (PPBS)*, unlike a conventional master budget, but like a ZBB, focuses on the output (programs or activities) of the organization. The thrust of PPBS is on the allocation of the organization's limited (cash) resources to those activities or programs that promise the greatest return. The following four steps usually are sufficient to constitute a PPBS:

1. Upper-level management must strategically plan the short- and long-range goals and objectives of the organization.
2. All the alternative activities or programs to achieve the organization's goals and objectives have to be identified.
3. The quantitative and qualitative costs and benefits of each alternative activity or program have to be forecasted.
4. A budget is prepared indicating which activities or programs have been selected with either a (least-efficient) lump-sum dollar allocation or a (most efficient) detailed item-by-item expenditure plan.

Developing the Master Budget

The starting point of a budget is the formulation of the strategic plan and related long-term goals of the company. The process of establishing the strategic plan and the long-term goals is commonly known as *strategic plan-*

ning. Management must decide where it would like its company to be in the future. The budget is used as a vehicle to move the company in the desired direction. All companies face limited resources and the budget is used to direct available resources to meet the long-term goals set by management. Once a budget is developed, it serves as a useful tool in controlling costs. Managers are expected to adhere to their budgets. A major factor in the evaluation of a manager's performance is his or her ability to operate effectively within the constraints of a budget.

The first step in developing the master budget is the *sales forecast*. The sales budget is the organization of the sales forecasts in terms of the projected unit and dollar sales for the planning periods. The process ends with the completion of the *budgeted financial statements*: the budgeted income statement, the cash budget, and the budgeted balance sheet. The budgeted financial statements are similar to the regular financial statements except that they deal with the future rather than the past.

Essentially there are two extremes in developing the master budget: (1) the upper management approach and (2) the grassroots approach. In the upper management approach, the chief officers, such as the top executives for sales, production, finance, and administration, forecast sales based on their experience and knowledge of the company and industry. In the grassroots approach, the forecasting begins at the bottom with individual salespeople. In most companies the approach actually adopted is somewhere between the two extremes, probably closer to the grassroots approach, with management utilizing the benefits of both general approaches.

The principal advantage of the upper management approach is that it is quick and it automatically has the support of upper management. An important disadvantage is that middle management, lower management, and other key employees do not participate in budgeting decisions and thus are not likely to give the cooperation and energy needed to make the budget a success. The principal advantage of the grassroots approach is that all levels in the company participate to some extent in developing the budget estimate and therefore are more likely to accept the budget and feel a responsibility to live within the limits established.

BUDGETED SCHEDULES

The budgeted schedules include the sales budget, production budget, selling and administrative budget, and cash budget. We describe each schedule below.

Sales Budget

The first step in the development of the master budget is to develop the sales budget. However, the foundation on which the sales budget and all other parts of the master budget rest is the sales forecast. If this forecast has been carefully and accurately prepared, the succeeding steps in the budget process will be that much more reliable. For example, the sales forecast provides the data for developing production budgets, purchasing budgets, and selling and administrative expense budgets. If the sales forecast is wrong, the related budgets will be that much less reliable.

In many companies the forecast of sales begins with the preparation of sales estimates by individual salespersons. These estimates are then forwarded to the appropriate district managers. At this point, forecasting procedures vary a great deal. Generally, district managers review the estimates and make adjustments on the basis of additional information or their own experience. The estimates are then consolidated and forwarded to the general marketing manager for review and approval. Methodologies for forecasting sales are described in Chapter 6.

Prior to the beginning of the process, certain basic external and internal data are developed by the general marketing manager's department or by a separate market research department of the company. This information will be made available, in some companies, to the district managers and even to the salespeople as an aid in developing the forecast. In other companies the information is made available only to the sales manager. Usually considered in the data are the following: general economic forecasts, industry sales and profits, inventory conditions, and competitive conditions. Internal information may also be provided in convenient form, such as past company sales and profits by product, by salesperson, by territory, and by channels of distribution. Many products will have a seasonal trend pattern that is different from that of any other product. This trend must be kept in mind when the annual forecast is established and the expected sales by months are set. Entire books have been devoted to forecasting and budgeting, and no attempt will be made to duplicate such detail here.

To keep the illustration simple, assume that the Chadwick Company manufactures and sells only one product and uses only one channel of distribution. If there were more products, a separate sales forecast would be made for each product. If more than one channel of distribution were used, each product's sales forecast would show a breakdown by channels of distribution such as wholesalers, jobbers, and/or retailers.

An analysis of sales by channel of distribution will show the amount each channel is contributing toward sales and net profits. If the percentage of net profit on sales to wholesalers or jobbers is very low, for example, it

may prompt the company to change its channel of distribution. Instead of selling to wholesalers or jobbers, the company may establish its own outlets and therefore retail its own products.

Assume that the Chadwick Company has completed the sales forecasting process, with the unit sales reported in Schedule 1a shown as Table 23.1. If the average selling price per unit is \$33, the dollar sales forecasted for the first quarter of 20XX is $9,400 \text{ units} \times \$33 = \$310,200$, as shown in the lower portion of this schedule.

Production Budget

The quantities for the production budget must be closely tied in with the sales budget and the desired inventory levels. Essentially, the *production budget* is the sales budget adjusted for inventory changes. Before much work is done on the production budget, it must be determined that the factory can produce the quantities estimated in the sales budget. Production should be scheduled at an efficient level so that there are no wide fluctuations in employment. To stabilize employment it is necessary also to maintain in-

TABLE 23.1 Schedule 1a: Sales Budget, First Quarter 20XX

Information required:

1. Sales budget, units
2. Sales price, per unit

Formula:

$$\text{Sales budget} = \text{Sales budget (units)} \times \text{Sales price per unit}$$

| | Territory | January | February | March | Quarter |
|------------------|-----------|-----------------|------------------|------------------|------------------|
| In units | 1 | 1,000 | 1,125 | 1,210 | 3,335 |
| | 2 | 600 | 650 | 675 | 1,925 |
| | 3 | 925 | 900 | 960 | 2,785 |
| | 4 | <u>430</u> | <u>450</u> | <u>475</u> | <u>1,355</u> |
| | Total | <u>2,955</u> | <u>3,125</u> | <u>3,320</u> | <u>9,400</u> |
| In sales dollars | 1 | \$33,000 | \$37,125 | \$39,930 | \$110,055 |
| | 2 | 19,800 | 21,450 | 22,275 | 63,525 |
| | 3 | 30,525 | 29,700 | 31,680 | 91,905 |
| | 4 | <u>14,190</u> | <u>14,850</u> | <u>15,675</u> | <u>44,715</u> |
| | Total | <u>\$97,515</u> | <u>\$103,125</u> | <u>\$109,560</u> | <u>\$310,200</u> |

Note: The sales price per unit is \$33.

ventories at an efficient level. If inventories are too low, production may be interrupted; if inventories are too high, carrying costs will be excessive.

The Chadwick Company desires that the following units of finished goods inventory be on hand at the following specified dates next year:

| Date | Units on hand |
|-------------|---------------|
| January 1 | 2,140 units |
| January 31 | 2,050 units |
| February 28 | 2,175 units |
| March 31 | 2,215 units |

Direct materials inventories are to be set at 60% of the following month's production requirements.

With the information provided by the sales budget (see Schedule 1a shown in Table 23.2) and these inventory estimates, the production budget can be developed. For an easier understanding of the budget illustrations, only the first three months of the year and only one production department are shown in Schedule 1b. Any additional months or departments would be largely repetitious.

As shown in Schedule 1b, the required number of units needed to be produced in the first quarter is 9,475. This number is then used to estimate the direct materials budget for the quarter.

TABLE 23.2 Schedule 1b: Production Budget, First Quarter 20XX

Information required:

1. Sales budget, units
2. Ending inventory, units
3. Beginning inventory, units

Formula:

$$\begin{array}{r} \text{Production} \\ \text{budget} \\ \text{(units)} \end{array} = \begin{array}{r} \text{Sales} \\ \text{budget} \\ \text{(units)} \end{array} + \begin{array}{r} \text{Desired ending} \\ \text{inventory} \\ \text{(units)} \end{array} - \begin{array}{r} \text{Beginning} \\ \text{inventory} \\ \text{(units)} \end{array}$$

| | Units | | | Quarter |
|------------------------------|--------------|--------------|--------------|--------------|
| | January | February | March | |
| Sales budget (schedule 1a) | 2,955 | 3,125 | 3,320 | 9,400 |
| Add desired ending inventory | <u>2,050</u> | <u>2,175</u> | <u>2,215</u> | <u>2,215</u> |
| Subtotal | 5,005 | 5,300 | 5,535 | 11,615 |
| Deduct beginning inventory | <u>2,140</u> | <u>2,050</u> | <u>2,175</u> | <u>2,140</u> |
| Production units required | <u>3,360</u> | <u>3,250</u> | <u>3,360</u> | <u>9,475</u> |

Cost of Manufacturing Budgets

The costs of manufacturing are estimated in the budgets for direct materials, direct purchases, and factory overhead. These three budgets are brought together in the cost of goods sold budget.

Direct Materials Purchases Budget

As was stated above, the Chadwick Company is to maintain an inventory of direct materials equal to 60% of the following month's production requirements. This is one of the first cost budgets to be prepared because the quantities to be purchased and delivery schedules must be quickly established so that direct materials are available when required. Usually there is a specification sheet or formula for each product showing the type and quantity of each direct material per unit of production.

Using the specification sheet, the purchasing department prepares purchasing and delivery schedules, which must be closely coordinated with the production budget and with the delivery schedules of the supplier. The budget for supplies and indirect materials is usually included in the factory overhead budget. The standard cost sheet for the Chadwick Company shows that one unit of direct materials is required for each unit of finished product. The contract price for direct materials is \$8.50 per unit until March 1, when it will increase to \$9 per unit. A direct materials purchase budget is also useful when projecting the financial requirements of a company.

The direct material purchase budget requires an estimate for the month's production following the quarter (in this case, April). For April the budgeted production units are estimated at 3,500 units. Therefore, $3,500 \times 60\% = 2,100$ units of direct material should be in the March ending inventory.

For the first quarter, the required units to be purchased and the related costs are shown by month and quarter in Schedule 1c, shown as Table 23.3. As shown in this schedule, the purchase of 9,856 units is required, with a total estimated cost of \$85,498.

Direct Materials Usage Budget

At about the same time that the purchases budget is prepared and the needed direct materials are ordered, it is necessary to prepare the *direct materials usage budget*. This budget becomes a useful tool when planning operating activities because it provides details on the direct materials to be used and the cost of these materials. The Chadwick Company's standard cost sheet shows that one unit of direct materials is required for each unit of finished product. The unit cost is the same as that used for purchases,

TABLE 23.3 Schedule 1c: Direct Material Purchases Budget, First Quarter 20XX

Information required:

1. Production budget, units
2. Ending inventory, units
3. Beginning inventory, units
4. Purchase price, per unit

Formula:

$$\text{Purchase of direct materials required (units)} \\ = \left[\begin{array}{cc} \text{Production} & \text{Direct materials} \\ \text{budget} & \text{required to} \\ \text{(units)} & \text{make one unit} \end{array} \right] \times \left[\begin{array}{cc} \text{Desired ending} & \text{Beginning} \\ \text{inventory} & \text{inventory} \\ \text{(units)} & \text{(units)} \end{array} \right] + \text{Desired ending inventory (units)} - \text{Beginning inventory (units)}$$

$$\text{Direct materials purchase cost} = \text{Purchase of direct materials required (units)} \times \text{Purchase cost per unit}$$

| | January | February | March | Quarter |
|---|-----------------|-----------------|-----------------|-----------------------------|
| Production required: | | | | |
| Units (from Schedule 1b) | 2,865 | 3,250 | 3,360 | 9,475 |
| Add desired ending inventory ^a | <u>1,950</u> | <u>2,016</u> | <u>2,100</u> | <u>2,100</u> |
| Subtotal | 4,815 | 5,266 | 5,460 | 11,575 |
| Deduct beginning inventory ^b | <u>1,719</u> | <u>1,950</u> | <u>2,016</u> | <u>1,719</u> |
| Purchases required (units) | 3,096 | 3,316 | 3,444 | 9,856 |
| Price per unit | × <u>\$8.50</u> | × <u>\$8.50</u> | × <u>\$9.00</u> | × <u>\$8.67^d</u> |
| Purchase cost ^c | <u>\$26,316</u> | <u>\$28,186</u> | <u>\$30,996</u> | <u>\$85,498</u> |

^a The desired ending inventory of 60% of the following month's production requirements.

^b The beginning inventory for January of 1,719 is 60% of that month's production requirements (2,865 × 60%), the same as the ending inventory of the previous month.

^c Rounded to the nearest dollar.

^d \$85,498 ÷ 9,856.

that is, \$8.50 for January and February and \$9 for March. The usage is budgeted as shown in Schedule 1d, in Table 23.4.

Direct Labor Budget

The direct labor requirements are usually developed by engineers on the basis of time studies and are essential in the development of the *direct labor budget*,

TABLE 23.4 Schedule 1d: Direct Materials Usage Budget, First Quarter 20XX*Information required:*

1. Direct materials production budget, in units
2. Purchase price, per unit

Formula:

$$\begin{aligned} &\text{Direct materials usage budget} \\ &= \text{Direct materials required (units)} \times \text{Direct materials unit cost} \end{aligned}$$

| | January | February | March | Quarter |
|---|-----------------|-----------------|-----------------|-----------------------|
| Direct materials units required (from Schedule 1b) | 2,865 | 3,250 | 3,360 | 9,475 |
| Direct materials unit cost | × \$8.50 | × \$8.50 | × \$9.00 | × \$8.68 ^a |
| Direct materials usage cost | <u>\$24,353</u> | <u>\$27,625</u> | <u>\$30,240</u> | <u>\$82,218</u> |

^a The sum of the monthly direct materials usage cost is \$82,218. Therefore, the direct materials unit cost is $\$82,218 \div 9,475 = \8.68 .

which details the wage cost and number of hours. The direct labor budget must be coordinated with the production budget, the purchasing budget, and all other parts of the master budget. Indirect labor is not included in the direct labor budget; rather it is included in the factory overhead budget.

The budgets for both direct and indirect labor must be translated by the personnel department into the types and numbers of employees needed, and when needed. If the production schedule calls for more workers than are now employed, the personnel department may have to provide a training program for new workers. If the budget plan for the next year requires fewer workers than presently employed, the personnel department prepares a list of workers to be laid off after considering each worker's skill and seniority rights, in accordance with company policy or union contract.

The standard cost data for Chadwick Company show that two hours of direct labor are required to complete one unit of finished product. The standard rate per hour at the overseas factory where the units will be produced is \$3 as of January 1, but is expected to rise to \$3.50 as of February 1. The direct labor budget, provided in Schedule 1e shown in Table 23.5, reflects the required direct labor hours, which was determined in Schedule 1b, and direct labor cost.

Factory Overhead Budget

Department heads should be held accountable for expenses incurred by their department. Any expenses allocated to the department should be shown separately from those for which the department head is directly responsible.

TABLE 23.5 Schedule 1e: Direct Labor Budget, First Quarter 20XX*Information required:*

1. Production budget, units
2. Direct labor hours, units
3. Direct labor rate per hour

Formula:

$$\begin{array}{r} \text{Direct} \\ \text{labor} \\ \text{budget} \end{array} = \begin{array}{r} \text{Production} \\ \text{units} \\ \text{required} \end{array} \times \begin{array}{r} \text{Direct} \\ \text{labor hours} \\ \text{per unit} \end{array} \times \begin{array}{r} \text{Direct} \\ \text{labor rate} \\ \text{per hour} \end{array}$$

| | January | February | March | Quarter |
|--|-----------------------------|-----------------------------|-----------------------------|-------------------------------|
| Production units required (from Schedule 1b) | 2,865 | 3,250 | 3,360 | 9,475 |
| Labor hours per unit | $\times \underline{2}$ | $\times \underline{2}$ | $\times \underline{2}$ | $\times \underline{2}$ |
| Direct labor hours | 5,730 | 6,500 | 6,720 | 18,950 |
| Multiply by rate per hour | $\times \underline{\$3.00}$ | $\times \underline{\$3.50}$ | $\times \underline{\$3.50}$ | $\times \underline{\$3.35^b}$ |
| Direct labor cost ^a | <u>\$17,190</u> | <u>\$22,750</u> | <u>\$23,520</u> | <u>\$63,460</u> |

^a Rounded to the nearest dollar.

^b $\$63,460 \div 18,950$.

Generally, the department head prepares budgets of the department for the budget period. After review by the budget committee, the department head may review and comment on any revision before it is made final. For better control, the fixed and variable expenses are separated as follows: Fixed expenses have total dollar values assigned, while variable expenses have rates assigned on the basis of, for example, direct labor hours. The budgets for the first three months of the year are shown in Schedule 1f, based on labor hours determined in Schedule 1e, shown as Table 23.6, of 5,730 for January, 6,500 for February, and 6,720 for March.

Ending Inventories Budget

Budgeted inventory amounts at month-end are needed for direct materials and finished goods inventory for the cost of goods sold budget and the budgeted balance sheet. The computations for these amounts, using a FIFO inventory method, are shown in Schedule 1g (see Table 23.7). The ending inventory cost depends in part on the beginning inventory cost for both direct materials and finished goods. The opening inventory of direct materials, January 1, 20XX, is $1,719 \text{ units} \times \$8.50 = \$14,612$, whereas the opening inventory of finished goods is $2,140 \text{ units} \times \$20.11 = \$43,035$.

TABLE 23.6 Schedule 1f: Factory Overhead Budget*Information required:*

1. Direct labor hours budget
2. Fixed expenses
3. Variable expenses

Formula:

$$\text{Factory overhead budget} = \text{Total fixed overhead} + \left[\frac{\text{Total budgeted direct labor hours}}{\text{per direct labor hour}} \times \text{Variable expense rate} \right]$$

January 20XX: Direct Labor Hours = 5,730

| Type of Expense | Fixed | Variable | Total |
|---|-----------------|----------------|-----------------|
| Indirect materials | \$1,200 | | \$1,200 |
| Indirect labor (variable: $\$0.50 \times 5,730$) | 1,500 | \$2,865 | 1,365 |
| Supervision | 1,250 | | 1,250 |
| Payroll taxes (variable: $\$0.30 \times 5,730$) | | 1,719 | 1,719 |
| Maintenance (variable: $\$0.20 \times 5,730$) | 500 | 1,146 | 1,646 |
| Heat and light (variable: $\$0.10 \times 5,730$) | 600 | 573 | 1,173 |
| Power (variable: $\$0.12 \times 5,730$) | 450 | 687 | 1,137 |
| Insurance | 650 | | 650 |
| Taxes | 1,000 | | 1,000 |
| Depreciation | 3,000 | | 3,000 |
| Miscellaneous (variable: $\$0.15 \times 5,730$) | | <u>860</u> | <u>860</u> |
| Total factory overhead | <u>\$10,150</u> | <u>\$7,850</u> | <u>\$18,000</u> |

February 20XX: Direct Labor Hours = 6,500

| Type of Expense | Fixed | Variable | Total |
|---|-----------------|----------------|-----------------|
| Indirect materials | \$1,200 | | \$1,200 |
| Indirect labor (variable: $\$0.50 \times 6,500$) | 1,500 | \$3,250 | 4,750 |
| Supervision | 1,250 | | 1,250 |
| Payroll taxes (variable: $\$0.30 \times 6,500$) | | 1,950 | 1,950 |
| Maintenance (variable: $\$0.20 \times 6,500$) | 500 | 1,300 | 1,800 |
| Heat and light (variable: $\$0.10 \times 6,500$) | 600 | 650 | 1,250 |
| Power (variable: $\$0.12 \times 6,500$) | 450 | 780 | 1,230 |
| Insurance | 650 | | 650 |
| Taxes | 1,000 | | 1,000 |
| Depreciation | 3,000 | | 3,000 |
| Miscellaneous (variable: $\$0.15 \times 6,500$) | | <u>975</u> | <u>975</u> |
| Total factory overhead | <u>\$10,150</u> | <u>\$8,905</u> | <u>\$19,055</u> |

TABLE 23.6 (Continued)
March 20XX: Direct Labor Hours = 6,720

| Type of Expense | Fixed | Variable | Total |
|---|-----------------|----------------|-----------------|
| Indirect materials | \$1,200 | | \$1,200 |
| Indirect labor (variable: $\$0.50 \times 6,720$) | 1,500 | \$3,360 | 4,860 |
| Supervision | 1,250 | | 1,250 |
| Payroll taxes (variable: $\$0.30 \times 6,720$) | | 2,016 | 2,016 |
| Maintenance (variable: $\$0.20 \times 6,720$) | 500 | 1,344 | 1,844 |
| Heat and light (variable: $\$0.10 \times 6,720$) | 600 | 672 | 1,272 |
| Power (variable: $\$0.12 \times 6,720$) | 450 | 806 | 1,256 |
| Insurance | 650 | | 650 |
| Taxes | 1,000 | | 1,000 |
| Depreciation | 3,000 | | 3,000 |
| Miscellaneous (variable: $\$0.15 \times 6,720$) | _____ | 1,008 | 1,008 |
| Total factory overhead | <u>\$10,150</u> | <u>\$9,206</u> | <u>\$19,356</u> |

Cost of Goods Sold Budget

The component parts for the cost of goods sold budget can be taken from the individual budgets previously described and adjusted for changes in inventory. This is shown in Schedule 1j (see Table 23.8).

Selling and Administrative Budgets

The selling and administrative expenses can be reflected in two budgets: one for selling expenses and one for administrative expenses. The selling expenses identifies marketing and other selling expenses by function and whether the expenses are fixed or variable. The administrative budget details the office and other administrative expenses.

Selling Expenses Budget

The *selling expenses budget* reflects expenses related to the sales function, which are made up of a number of items, some fixed and some variable. The principal fixed expenses are salaries and depreciation; the principal variable expenses such as commissions and advertising are based on sales dollars and thus vary directly with sales. Chadwick Company has the following variable selling expenses: commissions, 3% of gross sales; advertising, 1% of gross sales; bad debts, 2% of credit sales. (Credit sales were \$92,115 for January, \$96,925 for February, and \$102,060 for March.)

TABLE 23.7 Schedule 1g: Ending Inventories Budget, First Quarter, 20XX*Formula:*

$$\text{Budgeted ending inventory cost} = \text{Ending inventory (units)} \times \text{Standard cost per unit}$$

| | Units | × | Unit Cost | = | Amount |
|---|-------|---|-----------|---|----------|
| Direct materials inventory, month-end: | | | | | |
| January | 1,950 | | \$8.50 | | \$16,575 |
| February | 2,016 | | 8.50 | | 17,136 |
| March | 2,100 | | 9.00 | | 18,900 |
| January 1, 20XX (beginning inventory) | 1,719 | | 8.50 | | 14,612 |
| Finished goods inventory, month-end: ^a | | | | | |
| January | 2,050 | | \$20.78* | | \$42,599 |
| February | 2,175 | | 21.36* | | 46,458 |
| March | 2,215 | | 21.76* | | 48,198 |
| January 1, 20XX (beginning inventory) | 2,140 | | 20.11 | | 43,035 |

^a Unit cost:

| Month | Schedule 1h Manufacturing Cost | ÷ | Schedule 1b Production | = | Unit Cost |
|----------|-----------------------------------|---|---------------------------|---|--------------|
| January | \$59,543 | | 2,865 | | \$20.78 |
| February | 69,430 | | 3,250 | | 21.36 |
| March | 73,116 | | 3,360 | | 21.76 |

TABLE 23.8 Schedule 1h: Cost of Goods Sold Budget, First Quarter 20XX*Information required:*

1. Direct materials usage budget
2. Beginning finished goods inventory
3. Direct labor budget
4. Ending finished goods inventory
5. Factory overhead budget

Formula:

$$\begin{aligned} \text{Cost of goods sold} = & \text{Direct materials usage} + \text{Direct labor} + \text{Factory overhead} \\ & + \text{Beginning finished goods inventory} - \text{Ending finished goods inventory} \end{aligned}$$

TABLE 23.8 (Continued)

| Supporting Budgets | Schedule | January | February | March | Quarter |
|--|----------|-----------------|-----------------|-----------------|------------------|
| Direct materials usage budget | 1d | \$24,353 | \$27,625 | \$30,240 | \$82,218 |
| Direct labor budget | 1e | 17,190 | 22,750 | 23,520 | 63,460 |
| Factory overhead budget | 1f | <u>18,000</u> | <u>19,055</u> | <u>19,356</u> | <u>56,411</u> |
| Total manufacturing cost | | \$59,543 | \$69,430 | \$73,116 | \$202,089 |
| Add beginning finished goods inventory | 1g | <u>43,035</u> | <u>42,599</u> | <u>46,458</u> | <u>43,035</u> |
| Cost of goods available for sale | | \$102,578 | \$112,029 | \$119,574 | \$245,124 |
| Subtract ending finished goods inventory | 1g | <u>42,599</u> | <u>46,458</u> | <u>48,198</u> | <u>48,198</u> |
| Cost of goods sold | | <u>\$59,979</u> | <u>\$65,571</u> | <u>\$71,376</u> | <u>\$196,926</u> |

TABLE 23.9 Schedule 1i: Selling Expenses Budgets

Information required:

1. Sales dollars
2. Fixed expenses
3. Variable expenses

Formula:

$$\text{Selling expenses} = \frac{\text{Total fixed expenses}}{\text{per item}} + \left[\frac{\text{Sales}}{\text{dollars}} \times \frac{\text{Variable expense}}{\text{rate (\%) per item}} \right]$$

January 20XX: Sales Dollars = \$97,515

| Type of Expense | Fixed | Variable | Total |
|-----------------------------|----------------|----------------|-----------------|
| Salaries | \$3,000 | | \$3,000 |
| Commissions (3% × \$97,515) | | \$2,925 | |
| Travel (2% × \$97,515) | | 1,950 | 1,950 |
| Advertising (1% × \$97,515) | | 975 | 975 |
| Depreciation | 1,000 | | 1,000 |
| Bad debts (2% × \$92,115) | | 1,842 | 1,842 |
| Miscellaneous | <u>800</u> | <u> </u> | <u>800</u> |
| Total selling expenses | <u>\$4,800</u> | <u>\$7,692</u> | <u>\$12,492</u> |

The selling expenses budget for Chadwick Company for January, February, and March of the first quarter of the year 20XX are shown in Schedule 1i (see Table 23.9).

TABLE 23.9 (Continued)
 February 20XX: Sales Dollars = \$103,125

| Type of Expense | Fixed | Variable | Total |
|------------------------------|----------------|----------------|-----------------|
| Salaries | \$3,000 | | \$3,000 |
| Commissions (3% × \$103,125) | | \$3,094 | 3,094 |
| Travel (2% × \$103,125) | | 2,062 | 2,062 |
| Advertising (1% × \$103,125) | | 1,031 | 1,031 |
| Depreciation | 1,000 | | 1,000 |
| Bad debts (2% × \$96,925) | | 1,939 | 1,939 |
| Miscellaneous | <u>800</u> | <u> </u> | <u>800</u> |
| Total selling expenses | <u>\$4,800</u> | <u>\$8,126</u> | <u>\$12,926</u> |

March 20XX: Sales Dollars = \$109,560

| Type of Expense | Fixed | Variable | Total |
|------------------------------|----------------|----------------|-----------------|
| Salaries | \$3,000 | | \$3,000 |
| Commissions (3% × \$109,560) | | \$3,287 | 3,287 |
| Travel (2% × \$109,560) | | 2,191 | 2,191 |
| Advertising (1% × \$109,560) | | 1,095 | 1,095 |
| Depreciation | 1,000 | | 1,000 |
| Bad debts (2% × \$102,060) | | 2,041 | 2,041 |
| Miscellaneous | <u>800</u> | <u> </u> | <u>800</u> |
| Total selling expenses | <u>\$4,800</u> | <u>\$8,614</u> | <u>\$13,414</u> |

Administrative Expenses Budget

The *administrative expenses budget* captures the fixed expenses related to administration and support staff salaries, as well as depreciation, insurance, and other expenses related to administrative functions. The expenses in this category should be classified so that those individuals in the organization responsible for incurrence and control of particular expenses can be held accountable. In some instances, a portion of these expenses may be allocated to such operations as purchasing or research, but for this example all items will be considered to be nonallocable fixed expenses. Since they are fixed expenses, it will be necessary to have only one budget for each of the three months in the first quarter of 20XX. Schedule 1j (shown as Table 23.10) shows the administrative expenses budget.

TABLE 23.10 Schedule 1j: Administrative Expenses Budget per Month, First Quarter 20XX

Information required:

Fixed expenses

Formula:

$$\text{Administrative expenses budget} = \text{Sum of fixed expenses}$$

| Type of Expense | Total |
|--|----------------|
| Executive salaries..... | \$2,800 |
| Officesalaries..... | 500 |
| Insurance..... | 400 |
| Taxes..... | 200 |
| Depreciation..... | 800 |
| Miscellaneous..... | <u>500</u> |
| Total administrative expenses per month..... | <u>\$5,200</u> |

Cash Budget

The *cash budget* is a detailed analysis of cash inflows and outflows during the planning period. The cash budget is recognized as an essential management tool, and careful cash planning is considered a routine factor in efficient management. Good cash budgets aid significantly in stabilizing cash balances and keeping them reasonably close to continuing cash requirements. Cash budgets generally help in avoiding dangerous changes in cash position that may jeopardize the company's credit standing or possibly violate the provisions of a bond indenture. Careful cash planning must be made especially for large cash outlays such as payments on bank loans, retirement of securities, acquisitions of other companies, capital expenditures, pension contributions, and income tax installment payments.

In most enterprises, cash receipts are primarily from collections of accounts receivable and cash sales. The estimated amount of cash collections from accounts receivable is based on the cash collection experience of the company. A study of collections for a few months will indicate the general pattern of collections. For example, a study may show that 10% of the current month's credit sales are collected this month, 80% of last month's credit sales are collected this month, 8% of the credit sales of 2 months ago are collected this month, and 2% will be uncollectible. Assume that business began in December.

As an illustration, the above percentages are applied to the appropriate sales to arrive at the estimated collections for the first three months of the

year 20XX. The total sales for December 20XX, the first month of operation, and for the following three months are as follows: December, \$95,040; January, \$97,515; February, \$103,125; and March, \$109,560. The cash sales included in the total sales were: December, \$4,200; January, \$5,400; February, \$6,200; and March, \$7,500. There were no other cash receipts during this period. In Schedule 2a (see Table 23.11), the cash receipts forecast is shown, with detail regarding the total estimated cash collections for each month in the quarter. In Schedule 2b (see Table 23.12), the cash disbursements are shown.

Cash disbursements are based on the individual budgets previously prepared, with needed adjustments to change from the accrual basis to the cash basis. For example, direct materials purchased are not entirely paid for in the same month; payments are 60% in the month of purchase and 40% the next month. Some part of a payroll for the month is generally accrued at the end of the month and is not an outlay for the current month; however, the accrued portion for the previous month is an outlay this month. For simplicity, payroll accruals will not be shown. Of course, noncash items such as provisions for depreciation and bad debts do not require cash outlays. These amounts have to be deducted from the schedule totals for cash disbursement budget purposes.

In preparing the cash budget, the beginning cash balance is added to the estimated cash receipts to show the expected amount of cash available each month. From this amount the expected cash disbursements are deducted to determine the excess (or deficiency) of cash at the end of the month. If there is an excess, consideration must be given to possible short-term investment. If there is a deficit, the amount, for example, may be borrowed from a bank on some prearranged basis. Interest as well as principal must be included in any loan repayments. Generally, loan repayments are made at the end of a period.

Creating Chadwick's cash budget, using the following additional information:

- The beginning cash balance for the quarter is \$20,137.
- Purchases of direct materials have been converted to a cash basis.
- Depreciation, bad debts, and other noncash items must be deducted from the schedules for factory overhead, selling expenses, and administrative expenses.
- Cash outlays not included in expense schedules are income taxes, which are as follows: January, \$7,183; February, \$5,706; and March, \$6,453.
- Equipment purchases are projected as follows: January, \$22,000; February, \$10,000; and March, \$7,500.
- Management desires to maintain for operating purposes a cash balance of \$20,000.

TABLE 23.11 Schedule 2a: Cash Receipts, First Quarter 20XX

| | Collections Rate Current Month | Collections Rate Following Month | Collections Rate Two Months from Sales | Forecast | | |
|---------------------------------|-----------------------------------|-------------------------------------|---|----------|----------|-----------|
| | | | | January | February | March |
| December sales: | | | | | | |
| \$95,040 – \$4,200 = \$90,840 | 80% | 8% | | \$72,672 | \$7,267 | |
| January sales: | | | | | | |
| \$97,515 – \$5,400 = \$92,115 | 10% | 80% | 8% | 9,212 | 73,692 | \$7,369 |
| February sales: | | | | | | |
| \$103,125 – \$6,200 = \$96,925 | 10% | 80% | | | 9,693 | 77,540 |
| March sales: | | | | | | |
| \$109,560 – \$7,500 = \$102,060 | 10% | | | | | 10,206 |
| Cash sales | | | | 5,400 | 6,200 | 7,500 |
| Total cash receipts | | | | \$87,284 | \$96,852 | \$102,615 |

TABLE 23.12 Schedule 2b: Cash Disbursements, First Quarter 20XX

| | Disbursement Rate Current Month | Disbursement Rate Following Month | Forecast | | |
|--|------------------------------------|--------------------------------------|----------|----------|----------|
| | | | January | February | March |
| Disbursements from opening balance (assumed) | | | \$10,300 | | |
| January purchases: \$26,316 | 60% | 40% | 15,790 | \$10,526 | |
| February purchases: \$28,186 | 60% | 40% | | 16,912 | \$11,274 |
| March purchases: \$30,996 | 60% | | | | 18,598 |
| Total cash disbursements | | | \$26,090 | \$27,438 | \$29,872 |

- Any estimated deficiency below this amount at the end of a month is to be borrowed in increments of \$1,000 at the beginning of that month from the company's bank at the rate of 12% per annum.
- Interest is to be paid at the end of each month and principal is to be repaid when cash is available.

The cash budget is shown in Schedule 2c (see Table 23.13), which relies heavily on the schedules prepared so far. Incorporating information from these schedules, along with the other pieces of information, allows the calculation of the cash excess or cash deficiency. Any borrowings, repayments, and interest are shown in the financing section of this schedule.

BUDGETED SUMMARIES

Budgeted summaries include the budgeted income statement, budgeted statement of cash flows, and budgeted balance sheet. We describe each below.

Budgeted Income Statement

The final result of all the operations budgets such as sales, cost of goods sold, selling expenses, and administrative expenses is summarized in the *budgeted income statement*. This is a summary of the results of operations for the budget period. As can be seen in the budgeted income statement shown in Table 23.14, the sales are indicated as having an upward trend beginning with \$97,515 for January and \$103,125 for February, and increasing to \$109,560 for March. However, the net income does not show a proportionate increase. As the company moves into the budget period, the budget director will investigate the continuing rise in cost of goods sold and will endeavor to reduce costs. Possibly a material of lesser cost can be substituted, if quality can be maintained.

Budgeted Statement of Cash Flows

A statement of cash flows presents the change during the period in cash and cash equivalents (short-term, highly liquid investments). Cash receipts and cash payments are classified on a statement of cash flows according to operating, investing, and financing activities.

- Operating activities generally involve producing and delivering goods and providing services. Cash flows from operating activities are generally the cash effects of transactions and other events that enter into the determination of net income.

TABLE 23.13 Schedule 2c: Cash Budget, First Quarter 20XX*Information required:*

1. Cash balance, beginning
2. Budgeted cash receipts for period
3. Budgeted cash disbursements for period

Formula:

$$\text{Cash balance ending} = \text{Cash balance beginning} + \text{Budgeted cash receipts for the period} - \text{Budgeted cash disbursements for the period}$$

| | Source Schedule | January | February | March | Quarter |
|--------------------------------------|--------------------|-----------|-----------|-----------|-----------|
| Cash balance, beginning | | \$20,137 | \$20,758 | \$21,124 | \$20,137 |
| Cash receipts: | | | | | |
| Collections on account | 2a | \$81,884 | \$90,652 | \$95,115 | \$267,651 |
| Cash sales | 2a | 5,400 | 6,200 | 7,500 | 19,100 |
| Total cash receipts | | \$87,284 | \$96,852 | \$102,615 | \$286,751 |
| Total cash available | | \$107,421 | \$117,610 | \$123,739 | \$306,888 |
| Cash disbursements: | | | | | |
| Direct materials | 2b | \$26,090 | \$27,438 | \$29,872 | \$83,400 |
| Direct labor | 1e | 17,190 | 22,750 | 23,520 | 63,460 |
| Factory overhead ^a | 1f | 15,000 | 16,055 | 16,356 | 47,411 |
| Selling expenses ^b | 1i | 9,650 | 9,987 | 10,373 | 30,010 |
| Administrative expenses ^a | 1j | 4,400 | 4,400 | 4,400 | 13,200 |
| Income taxes | | 7,183 | 5,706 | 6,453 | 19,342 |
| Equipment purchases | | 22,000 | 10,000 | 7,500 | 39,500 |
| Total cash disbursements | | \$101,513 | \$96,336 | \$98,474 | \$296,323 |
| Excess (or deficiency) | | \$5,908 | \$21,274 | \$25,265 | \$10,565 |
| Financing: | | | | | |
| Borrowing, beginning of month | | \$15,000 | | | \$15,000 |
| Repayment, end of month | | | | \$(5,000) | (5,000) |
| Interest, 12% ^c | | (150) | \$(150) | (150) | (450) |
| Effect of financing | | \$14,850 | \$(150) | \$(5,150) | \$9,550 |
| Cash balance, end | | \$20,758 | \$21,124 | \$20,115 | \$20,115 |

^a Less depreciation.^b Less depreciation and bad debts.^c Interest computations: $\$15,000 \times 0.12 \times 1/12 = \150 .

TABLE 23.14 Statement 1: Budgeted Income Statement, First Quarter 20XX

| Supporting Budgets | Schedule | January | February | March | Quarter |
|--------------------------|----------|-----------------|-----------------|-----------------|------------------|
| Sales | 1a | \$97,515 | \$103,125 | \$109,560 | \$310,200 |
| Cost of goods sold | 1h | <u>59,979</u> | <u>65,571</u> | <u>71,376</u> | <u>196,926</u> |
| Gross profit | | <u>\$37,536</u> | <u>\$37,554</u> | <u>\$38,184</u> | <u>\$113,274</u> |
| Operating expenses: | | | | | |
| Selling expenses | 1i | \$12,492 | \$12,926 | \$13,414 | \$38,832 |
| Administrative expenses | 1j | 5,200 | 5,200 | 5,200 | 15,600 |
| Interest expense | 2c | <u>150</u> | <u>150</u> | <u>150</u> | <u>450</u> |
| Total operating expenses | | <u>\$17,842</u> | <u>\$18,276</u> | <u>\$18,764</u> | <u>\$54,882</u> |
| Net income before taxes | | \$19,694 | \$19,278 | \$19,420 | \$58,392 |
| Income taxes (assumed) | | <u>7,183</u> | <u>5,706</u> | <u>6,453</u> | <u>19,342</u> |
| Net income | | <u>\$12,511</u> | <u>\$13,572</u> | <u>\$12,967</u> | <u>\$39,050</u> |

- Investing activities include making and collecting loans and acquiring and disposing of debt or equity instruments and property, plant, and equipment and other productive assets, that is, assets held for or used in the production of goods or services by the enterprise (other than materials that are part of the enterprise's inventory).
- Financing activities include obtaining resources from owners and providing them with a return on, and a return of, their investment; borrowing money and repaying amounts borrowed, or otherwise settling the obligation; and obtaining and paying for other resources obtained from creditors on long-term credit.

In reporting cash flows from operating activities, enterprises are encouraged to report major classes of gross cash receipts and gross cash payments and their arithmetic sum—the net cash flow from operating activities (the direct method). Enterprises that choose not to provide information about major classes of operating cash receipts and payments by the direct method may determine and report the same amount for net cash flow from operating activities indirectly by adjusting net income to reconcile it to net cash flow from operating activities; the latter is referred to as the *indirect method* or the *reconciliation method*. The reconciliation of net income to cash flows requires adjusting net income to remove (1) the effects of all deferrals of past operating cash receipts and payments, such as changes during the period in inventory, deferred income, and the like, and all accruals of expected future operating cash receipts and payments, such as changes during the period in receivables and payables, and (2) the effects of all items whose cash effects

are investing or financing cash flows, such as depreciation, amortization of goodwill, and gains or losses on sales of property, plant, and equipment.

The reconciliation of net income to net cash flows from operating activities is required regardless of whether the direct or indirect method of reporting net cash flows from operating activities is used. The reconciliation separately reports all major classes of reconciling items. For example, major classes of deferrals of past operating cash receipts and payments and accruals of expected future operating cash receipts and payments, including changes during the period in receivables, inventory, and payables, are items to be considered when reconciling net income to cash flows from operating activities.

If the direct method of reporting net cash flow from operating activities is used, the reconciliation of net income to net cash flow from operating activities should be provided in a separate schedule, with the statement of cash flows reporting only the net cash flow from operating activities.

Table 23.15 presents an overview of the cash flows relating to operating, investing, and financing activities. Table 23.16 presents the items that should be considered when reconciling net income to net cash provided by operating activities.

TABLE 23.15 Overview of Cash Flows

| Statement of Cash Flows | |
|---|--|
| Cash Inflows | Cash Outflows |
| Operating | |
| <ul style="list-style-type: none"> • Sales (customers) • Interest income (loans) • Dividend income (equity securities) • Miscellaneous income | <ul style="list-style-type: none"> • Suppliers and employees • Interest expense (creditors) • Taxes (government) • Miscellaneous expenses |
| Investing | |
| <ul style="list-style-type: none"> • Sale of property, plant, and equipment • Sale of debt or equity securities of other entities • Collection of loans (principal portion) made to other entities | <ul style="list-style-type: none"> • Purchase of property, plant, and equipment • Purchase of debt or equity securities of other entities • Payment for loans made to other entities |
| Financing | |
| <ul style="list-style-type: none"> • Issuance of debt (notes and bonds) • Issuance of equity securities • Investments by partners | <ul style="list-style-type: none"> • Repayment of debt • Reacquisition of equity securities (treasury stock) • Dividends to stockholders • Disinvestment by partners • Partners' drawings |

TABLE 23.16 Reconciliation of Net Income to Net Cash Provided by Operating Activities

| Net Income | |
|---|---|
| Add | Deduct |
| <ul style="list-style-type: none"> • Depreciation expense • Amortization (bond discount) • Amortization of deferred charges and intangibles • Increase in deferred tax liabilities • Decrease in deferred tax assets • Losses under the equity method • Losses on sale of property, plant, or equipment • Decrease in receivables • Decrease in inventories • Decrease in prepaid expenses • Increase in accounts payable and accrued liabilities • Minority interest in net income of subsidiary | <ul style="list-style-type: none"> • Amortization (bond premium) • Decrease in deferred tax liabilities • Increase in deferred tax assets • Gains under the equity method • Gains on sale of property, plant, or equipment • Increase in receivables • Increase in inventories • Increase in prepaid expenses • Decrease in accounts payable and accrued liabilities |
| = Net cash provided by operating activities | |

The *budgeted statement of cash flow* organizes the information from the preceding schedules in terms of the sources of the cash flows: operating, investing, or financing activities. Table 23.17 presents a budgeted statement of cash flows for Chadwick Company.

Budgeted Balance Sheet

The *budgeted balance sheet* represents the assets, liabilities, and equity for the end of the budgeted period. The budgeted balance sheet for March 31, 20XX, is shown in Table 23.18.

BOTTOM LINE

- Budgeting has become one of the most universally accepted tools of management today. The master or comprehensive budget is one of the most effective means of planning and control.
- The budget has found its way into a multitude of functions consisting of control, performance evaluation, activity coordination, and plan implementation, to name just a few. The company's goals and objectives are built into an overall budget plan, and a reliable yardstick is provided to measure the performance not only of departments but also of many individuals entrusted with carrying out various budget responsibilities.

TABLE 23.17 Statement 2: Budgeted Cash Flow Statement

| Chadwick Company Budgeted Statement of Cash Flows for Three Months Ended March 31, 20XX | | |
|--|-------------------|-----|
| Cash Flows from Operating Activities: | | |
| Cash received from customers | \$286,751 | (a) |
| Cash paid to suppliers and employees | (237,481) | (b) |
| Interest paid | (450) | |
| Income taxes paid | <u>(19,342)</u> | |
| Net cash provided by operating activities | <u>\$29,478</u> | |
| Cash Flows from Investing Activities: | | |
| Equipment purchases | <u>\$(39,500)</u> | |
| Net cash used in investing activities | <u>(39,500)</u> | |
| Cash Flows from Financing Activities: | | |
| Proceeds from borrowing | \$15,000 | |
| Repayments of borrowings | <u>(5,000)</u> | |
| Net cash provided by financing activities | <u>10,000</u> | |
| Net decrease in cash and cash equivalents | \$(22) | |
| Cash and cash equivalents at beginning of year | <u>20,137</u> | |
| Cash and cash equivalents at end of year | <u>\$20,115</u> | |
| (a) Collections on account | \$267,651 | |
| Cash sales | <u>19,100</u> | |
| Total cash collections | <u>\$286,751</u> | |
| (b) Direct materials (Schedule 2c) | \$83,400 | |
| Direct labor | 63,460 | |
| Factory overhead | 47,411 | |
| Selling expenses | 30,010 | |
| Administrative expenses | <u>13,200</u> | |
| Total | <u>\$237,481</u> | |

TABLE 23.17 (Continued)

| Reconciliation of Net Income to Net Cash Provided by Operating Activities: | | |
|--|-----------------|---|
| | | Source |
| Net income | \$39,050 | Budgeted Income Statement |
| Adjustments to reconcile net income to net cash provided: | | |
| Depreciation | \$14,400 | (a) |
| Change in assets and liabilities: | | |
| Increase in net accounts receivable | (17,627) | (b) |
| Increase in direct materials purchases over usage | (3,280) | (c) |
| Increase in finished goods inventory | (5,163) | (d) |
| Increase in accounts payable | <u>2,098</u> | (e) |
| | <u>(9,572)</u> | |
| Net cash provided by operating activities | <u>\$29,478</u> | Statement of Cash Flows |
| <hr/> | | |
| (a) Factory overhead | \$9,000 | (schedule 1f) |
| Selling expense | 3,000 | |
| Administrative expense | <u>2,400</u> | |
| Total depreciation | <u>\$14,400</u> | |
| (b) Accounts receivable—net, March 31 | \$97,566 | Reconciliation of Net Income to Net Cash Provided by Operating Activities |
| Accounts receivable—net, January 1 | <u>79,939</u> | Reconciliation of Net Income to Net Cash Provided by Operating Activities |
| Increase in net accounts receivable | <u>\$17,627</u> | |
| (c) Direct materials purchase budget | \$85,498 | (schedule 1c) |
| Direct materials usage budget | <u>82,218</u> | (schedule 1d) |
| Increase in direct materials purchases over usage | <u>\$3,280</u> | |
| (d) Finished goods inventory, March 31 | \$48,198 | (schedule 1g) |
| Finished goods inventory, January 1 | <u>43,035</u> | (schedule 1g) |
| Increase in finished goods inventory | <u>\$5,163</u> | |
| (e) Accounts payable, March 31 | \$12,398 | Reconciliation of Net Income to Net Cash Provided by Operating Activities |
| Accounts payable, January 1 | <u>10,300</u> | (schedule 2b) |
| Increase in accounts payable | <u>\$2,098</u> | |

TABLE 23.18 Statement 3: Budgeted Balance Sheet, March 31, 20XX

| Chadwick Company Budgeted Balance Sheet March 31, 20XX | | |
|--|------------------|---------------|
| <i>Assets</i> | | <i>Source</i> |
| Current assets: | | |
| Cash | \$20,115 | Table 23.3 |
| Accounts receivable (net) | 97,566 | (a) |
| Materials inventory | 18,900 | Schedule 1g |
| Finished goods inventory | <u>48,198</u> | Schedule 1g |
| Total current assets | <u>\$184,779</u> | |
| Noncurrent assets: | | |
| Land | \$35,000 | (b) |
| Building and equipment | \$200,000 | (c) |
| Less accumulated depreciation | <u>50,000</u> | (d) |
| Net building and equipment | <u>150,000</u> | |
| Total noncurrent assets | <u>\$185,000</u> | |
| Total assets | <u>\$369,779</u> | |
| <i>Liabilities and Stockholders' Equity</i> | | |
| Liabilities: | | |
| Accounts payable | \$12,398 | (e) |
| Loan payable | <u>10,000</u> | |
| Total liabilities | <u>\$22,398</u> | |
| Common stock \$5 par, 20,000 outstanding | \$100,000 | (f) |
| Retained earnings | <u>247,381</u> | (g) |
| Total stockholders' equity | <u>347,381</u> | |
| Total liabilities and stockholders' equity | <u>\$369,779</u> | |

(a) Accounts receivable beginning balance of \$79,939 + \$291,100 of credit sales = \$371,039 – \$273,473 (\$267,651 collections + \$5,822 bad debts).

(b) Assumed.

(c) Assume beginning balance of \$160,500 + acquisitions of \$39,500.

(d) Accumulated depreciation assumed beginning balance of \$35,600 + \$14,400 of depreciation expense for first quarter.

(e) Accounts payable beginning balance of \$10,300 + \$85,498 of purchases – \$83,400 of payments.

(f) Common stock assumed balance of \$100,000.

(g) Retained earnings assumed beginning balance of \$208,331 + \$39,050 net income.

- Budgets may be grouped into two broad categories: (1) budget schedules and (2) budget summaries. Budget schedules include those for sales, production, materials, cash, and so on. Budget summaries combine the data from the various schedules plus supporting information; they include the budgeted income statement and the budgeted balance sheet.
- Budgets for direct materials, direct labor, and factory overhead are essential in determining the amount and timing of cash disbursements. Selling and administrative expenses budgets must also be considered, as well as income and other taxes, capital expenditures, loan repayments, and cash dividends, in establishing budgeted cash disbursements.
- The cash budget bridges the cash activities from the income statement to the balance sheet. For example, budgeted sales from the income statement are essential in determining the amount and timing of cash collections of accounts receivable from the balance sheet.
- The budgeted income statement shows what profitable operations are expected to be in the upcoming periods and can be used as a reliable measure of what operations should be. Any significant variations should be investigated.
- The budgeted balance sheet incorporates all changes in assets, liabilities, and capital since the last balance sheet; it can indicate critical unfavorable or favorable ratios before they actually occur.
- With appropriate monitoring of budgets and results, the CFO has an advanced warning system in place, allowing the CFO to take the necessary steps to correct the anticipated problem.

Standard Costing

AGENDA

- Item 1* Define standards and discuss how they are developed.
- Item 2* Explain the difference between actual, normal, and standard costing.
- Item 3* Understand the uses of standard costing.
- Item 4* Identify the three basic types of standards.
- Item 5* Explain the establishment of direct materials standards, direct labor standards, and factory overhead standards.
- Item 6* Differentiate between a static budget and a flexible budget.
- Item 7* Briefly discuss how standards are established for a more complex process cost or job order cost system.
- Item 8* Discuss quality and the measures that can be used to measure quality costs.
- Item 9* Explain the philosophy of the just-in-time (JIT) management strategy and its view of the factors that drive the cost of manufacturing.
- Item 10* Explain the role of variances in managing and evaluating costs.
- Item 11* Identify the types of variances that exist and discuss standard costing with respect to the computation and analysis of these variances.
- Item 12* Compute the direct materials price variance and the direct materials efficiency (usage) variance.
- Item 13* Calculate the direct labor price (rate) variance and the direct labor efficiency variance.
- Item 14* Compute factory overhead variances using the one-, two-, and three-factor analysis methods.

The cost of manufacturing a product may be predetermined before production begins or computed when production is completed. A cost accumulation system (either job order costing or process costing) may therefore apply predetermined costs to units as they are produced, rather than waiting for actual cost data to be accumulated. In this chapter we present a discus-

sion of the concept of what standards are and how they are developed, the computation and analysis of variances (differences between standard and actual costs), and the end-of period disposition of variances.

ACTUAL, NORMAL, AND STANDARD COSTING

In an actual cost system, product costs are recorded only when they are incurred. This technique is usually acceptable for the recording of direct materials and direct labor because they can be easily traced to specific jobs (job order costing) or departments (process costing). Factory overhead, the indirect cost component of a product, usually cannot be easily traced to a specific job or department. Since factory overhead is not a direct cost of production, a modification of an actual cost system, called *normal costing*, is commonly used. Under normal costing direct materials and direct labor costs are accumulated as they are incurred, with one exception. The exception is that factory overhead is applied to production on the basis of actual inputs (hours, units, etc.) multiplied by a predetermined factory overhead application rate. Under standard costing, *all* costs attached to products are based on standard or predetermined amounts. Standard costs represent the *planned* costs of a product and are generally established well before production begins. The establishment of standards thus provides management with goals to attain (i.e., planning) and bases for comparison with actual results (i.e., control).

Standard costs are those expected to be achieved in a particular production process under normal conditions. Standard costing is concerned with cost *per unit* and serves basically the same purpose as a budget. Budgets, however, quantify managerial expectations in terms of *total* costs rather than in terms of per-unit costs. Standard costs do not replace actual costs in a cost accumulation system. Instead, standard costs and actual costs are both accumulated. Standard costs are also known as *planned costs*, *predicted costs*, *scheduled costs*, and *specification costs*. Estimated costs are purposely omitted from this list because the word *estimated* should not be used interchangeably with the word *standard*. *Estimated costs* have historically been used as projections of what per-unit costs will be for a period, while *standard costs* are what a unit cost of a product *should be*. Therefore, while estimated costs are merely an anticipation of actual results, standard costs are objectives set by management that function as controls for monitoring actual results. In addition, standard costs are built into a cost system while estimated costs are not.

USES OF STANDARD COSTS

Cost information may be used for many different purposes. It should be noted that cost information that serves one purpose may not be appropriate for another. Therefore, the purpose for which cost information is to be used should be clearly defined before procedures are developed to accumulate cost data. Standard costs may be used for (1) cost control, (2) inventory costing, (3) budgetary planning, (4) product pricing, and (5) record-keeping.

Cost Control

The objective of cost control is to aid management in the production of a unit of usable product or service, at the lowest possible cost, in accordance with predetermined quality standards. Standards enable management to make periodic comparisons of actual costs with standard costs in order to measure performance and correct inefficiencies.

Inventory Costing

Two views are held by accountants concerning inventory costing. One group maintains that inventory should be stated in standard cost terms and that cost caused by inefficiency and idle production should be written off as period costs. The other group maintains that all costs incurred in the production of a unit should be included in *inventory cost*. The Committee on Accounting Procedures, in *Accounting Research Bulletin No. 43*, has taken the following position:

Standard costs are acceptable if adjusted at reasonable intervals to reflect current conditions, so that at the balance-sheet date standard costs reasonably approximate costs computed under one of the recognized bases. In such cases, descriptive language should be used which will express this relationship, as, for instance, "approximate costs determined on a first-in, first-out basis," or, if it is desired to mention standard cost, "at standard costs, approximating actual costs."

Therefore, for purposes of preparing external financial statements, inventories costed at standard must be adjusted if necessary to approximate actual costs.

Budgetary Planning

Standard costs and budgets are similar because they both represent planned costs for a specific period. Standard costs are very useful when developing a budget, since they form the building blocks of a total cost goal (or budget). Budgets, in effect, are standard costs multiplied by the volume or activity level expected.

Product Pricing

The selling price of a unit and the cost per unit are usually closely related. In most cases, a change in the selling price of a unit will result in a change in the number of units sold and, accordingly, the number of units that should be produced. As the number of units produced changes, so will the unit cost as fixed factory overhead costs will be spread over a different number of units. For example, a decrease in the selling price of a unit usually results in more units being sold. As more units are sold, unit costs decrease because fixed factory overhead is spread over a larger number of units. Management attempts to achieve the best combination of price and volume for a particular time period, thereby maximizing profits. Standard costs aid management in the decision process by providing projected standard costs for various levels of activity.

Record-Keeping

Detailed record-keeping may be reduced when standard costs are used in conjunction with actual costs. For example, when inventories are kept at standard cost, the inventory ledgers need only keep track of quantities.

TYPES OF STANDARDS

There are three basic types of standards that may be employed: fixed (basic), ideal, and attainable.

A *fixed standard* (also called a *basic standard*), once established, is unchanging. Such a standard may be ideal or attainable when initially established, but it is never altered once it has been set. Because of the obvious diminution of utility to management over a span of time, fixed standards are rarely used in manufacturing concerns.

An *ideal standard* is computed using utopian conditions for a given manufacturing process. Ideal standards presume that direct material, direct labor, and factory overhead items will be acquired at the minimum price in

all cases. Ideal standards also are based on the optimal usage of the direct material, direct labor, and factory overhead components at 100% manufacturing capacity. In reality, ideal standards cannot be met and will give rise to unfavorable variances.

Attainable standards are standards based on a high degree of efficiency, but they differ from ideal standards in that they can be met or even surpassed by the employment of efficient operations. Attainable standards consider that the component parts (direct material, direct labor, and factory overhead) can be acquired at a good overall price, not necessarily the lowest price at all times, but well below the expected highest price. Attainable standards also consider that (1) direct labor is not 100% efficient; (2) when direct material is used there will be some “normal” spoilage; and (3) a manufacturer cannot produce at 100% capacity. Attainable standards are set above average levels of efficiency but may be met or surpassed by efficient production.

Although most companies presently use attainable standards, a new manufacturing environment is developing that emphasizes ideal standards. The building of a certain amount of inefficiency into standards is no longer viewed as a desirable outcome. The goal of continuous improvement has become an overriding issue.

ESTABLISHMENT OF STANDARDS

An integral part of any standard cost system is the setting of standards for direct materials, direct labor, and factory overhead.

Direct Materials Standards

Direct materials cost standards may be divided into price (rate) standards and efficiency (usage) standards.

Direct Materials Price (Rate) Standards

Price standards are the *unit* prices at which direct materials *should* be purchased. Even though standard costs are stated on a per-unit basis, management must still estimate total sales for the next period before individual standards can be set. The sales forecast is of utmost importance because it will first determine the total units of finished goods that will have to be produced and then determine the total quantity of direct materials that will have to be purchased during the next period. Most suppliers will offer substantive quantity discounts on the basis of increasing quantities of direct materials expected to be ordered for the entire period. Once the quantity to

be purchased has been determined, the net purchase price can be established by the supplier.

Management must set quality and delivery standards before a standard price per unit can be determined. The cost accounting department and/or the purchasing department are normally responsible for setting direct material price standards since they have ready access to price data and should have knowledge of market conditions and other relevant factors. The purchasing department is responsible for canvassing suppliers to determine which supplier will give the best price at the desired quality level and within the constraints of delivery and other requirements.

Most suppliers will want the option to change their prices during the period to reflect increases in their cost. If this arrangement exists, management should consider increasing the initial standard price per unit to a standard weighted average price per unit to reflect subsequent projected price increases for the period. As a more preferable alternative under conditions of expected purchase price changes, the cost accounting department and/or the purchasing department may periodically have to alter the standard price per unit in response to actual purchase price changes.

The standard-setting process for direct materials can be very time consuming, especially for large manufacturing companies that must set standards for hundreds of different suppliers. When more than one direct material is used in a production process, a standard unit price must be computed for each individual direct material.

Many manufacturing companies have designated managers of separate departments who are assigned the sole responsibility of setting standards.

Direct Materials Efficiency (Usage) Standards

Quantity or usage efficiency standards are predetermined specifications of the *quantity* of direct materials that *should* go into the production of one finished unit. If more than one direct material is required to complete a unit, individual standards must be computed for each direct material. The number of different direct materials and the related quantities of each required to complete one unit can be developed from engineering studies, analysis of past experiences using descriptive statistics, and/or test runs under controlled conditions.

The engineering department, because it designs the production process, is in the best position to set realistically attainable quantity standards. We use an example for a hypothetical company to illustrate the setting of standards. We use this example throughout this chapter to explain how departures from standards (or variances) are computed and analyzed. The company will be called Standard Corporation. To simplify matters, assume that

Standard Corporation uses a process cost accumulation system and does all its manufacturing in one department.

Standard Corporation produces clown costumes and it expects to sell all the units (costumes) it produces. It plans to produce 2,000 finished units during the next period and sell them for \$100 each.

Engineering studies, confirmed by past experience, indicate that one finished unit requires 2 yards of cloth (direct materials). The Purchasing Department found a supplier that will provide the 4,000 yards ($2,000 \times 2$) required annually at \$5 per yard. With this information the following standards have been set for 20X2:

| | |
|--|------------------|
| Direct materials price standard | \$5 per yard |
| Direct materials efficiency (usage) standard | 2 yards per unit |

Direct Labor Standards

Direct labor cost standards like direct materials may be divided into price standards (labor rate) and efficiency standards (labor hours).

Direct Labor Price Standards

Price (rate) standards are predetermined *rates* for a period. The standard rate of pay that an individual will receive is usually based on the type of job being performed and the experience that the person has had on the job. The wage rate of most manufacturing corporations is usually set forth in the union contract. If a nonunion shop exists, the wage rate will usually be determined by management in consultation with the personnel department. If the union contract calls for an increase in pay during the year, this change must be incorporated into the standard wage rate and may necessitate the development of a standard weighted average rate per hour. As in the comparable case with anticipated direct material price changes, a more preferable alternative would be to alter the standard price per hour periodically in response to actual rate changes. Items like vacation pay and sick pay are usually not included in the standard rate of pay because they are normally accounted for as part of factory overhead.

Direct Labor Efficiency Standards

Efficiency standards are predetermined *performance* standards for the amount of direct labor hours that should go into the production of one finished unit. Time-and-motion studies are helpful in developing direct labor efficiency standards. In these studies, an analysis is made of the procedures fol-

lowed by workers and the conditions (space, temperature, equipment, tools, lighting, etc.) under which workers must perform their assigned tasks.

When a company introduces a new product or a new manufacturing process, the amount of direct labor hours required to produce one unit will usually decrease as workers become more familiar with the process. Studies have shown that the average time (hours) required to complete one unit will decrease at a constant percentage rate from the first job or unit, until complete learning has taken place. The effect of the learning process on workers may be visually shown in what is technically called the *learning curve*. The learning curve is based on statistical findings indicating that as the cumulative number of units produced *doubles*, the average direct labor time required per unit will decrease at a constant percentage (normally ranging from 10% to 40%). These percentages are commonly called *cost reduction percentages*.

Time-and-motion studies may be used to determine the percentage to be applied to a specific production process. The cost reduction percent designated on the curve is the complement of the learning rate (one minus the learning rate); therefore, if average direct labor time required per unit decreases by 30% after production doubles, the curve is referred to as a “70% learning curve.” The period in which the output per hour increases is known as the “learning stage.” There is both a physical and a mechanical limit that will be reached beyond which any further improvements in output per hour can be achieved only by changing the nature of the production process itself or by improving the equipment used. The period in which the output per hour stabilizes is known as the “constant stage.” After workers have been in the constant stage for long periods of time, it is possible that productivity may start to decrease because the challenge and excitement of learning a new production process are over and boredom sets in. Management must be alert to detect any decreases in productivity and take steps to avoid or correct this hypothetical “boredom stage.” Many companies routinely shift workers to different job assignments within a tedious process as a simple and effective means of preventing the boredom stage from developing.

Table 24.1 shows an 80% learning curve (for 16 units of production) where the first unit takes 5 hours to complete. Doubling the quantity produced results in the average completion time per unit being decreased by 20% of the average completion time per unit of the last unit produced.

Figure 24.1 is a graphic presentation of the learning curve. The points where output per hour (on the vertical axis) intersects the corresponding cumulative units of production (on the horizontal axis) are plotted on the graph and then connected. The learning curve should be used from the beginning of a new process to the end of the learning stage. The costs that are most affected by the learning process are direct labor and related vari-

TABLE 24.1 Computations for 80% Learning Curve, Direct Labor Hours

| Cumulative Units of Production | Cumulative Average/Unit (Hours) | Total Time Needed (Hours) | Output per Hour |
|--------------------------------|---------------------------------|---------------------------|-----------------|
| 1 | 5 | 5 | 0.20(1 ÷ 5) |
| 2 | 4 (5 × 0.80) | 8 | 0.25(2 ÷ 8) |
| 4 | 3.2 (4 × 0.80) | 12.8 | 0.31(4 ÷ 12.8) |
| 8 | 2.56 (3.2 × 0.80) | 20.5 | 0.39(8 ÷ 20.5) |
| 16 | 2.05 (2.56 × 0.80) | 32.8 | 0.49(16 ÷ 32.8) |

FIGURE 24.1 The Learning Curve

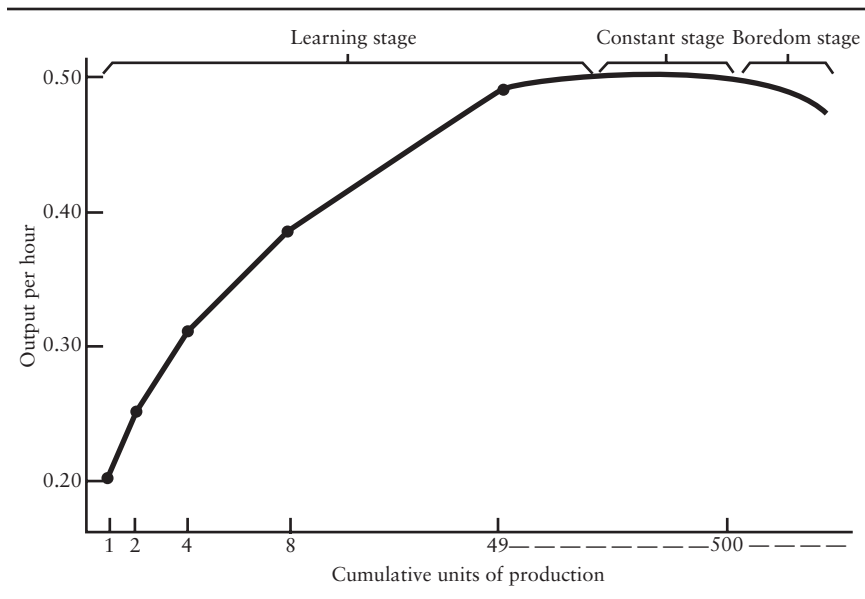

able factory overhead. As the workers increase their output per hour, the direct labor cost per unit will be decreasing. The learning process will be most noticeable where processes are complex or require dexterity. If a new process is fully automated, the learning curve will not be needed to determine estimated per-unit direct labor costs.

In determining standard costs or preparing budgets, unless there is complete automation, failure to take the learning process into consideration may result in erroneous efficiency standards that could have adverse effects on managerial decision making (such as overbidding contracts).

Procedures and conditions are closely related and, therefore, a change in one is usually accompanied by a change in the other. For example, the introduction of an additional piece of equipment into an assembly line would require a change in procedures followed by workers. When either the situation or procedures are changed, a new standard should be developed. Time-and-motion studies should be performed for all steps in the production process.

Time-and-motion engineers are usually given the responsibility for setting direct labor efficiency standards. The engineers should have a thorough knowledge of the production process to complement their knowledge of the techniques of time-and-motion studies. Many large companies have departments staffed by engineers devoted solely to the establishment of direct labor efficiency standards.

Factory Overhead Standards

The concept of standard setting for factory overhead is similar to standard setting for direct materials and direct labor. However, although the basic concept is similar, the procedures used to compute standard costs for factory overhead are quite different.

One reason for different procedures in developing factory overhead standards is the variety of items comprising the factory overhead cost pool. Factory overhead includes indirect materials, indirect labor, and all other indirect manufacturing costs such as factory rent, depreciation of factory equipment, and so on. The individual costs that make up total factory overhead are affected differently by increases or decreases in plant activity. Depending on the cost item, plant activity may cause a proportional change (variable factory overhead costs), a disproportionate change (mixed factory overhead costs), or no change (fixed factory overhead costs) in total factory overhead costs.

Because of the different items included in factory overhead, the setting of factory overhead standards involves many individuals within the company. For example, a building and grounds department manager may be responsible for cleaning costs; a production department manager may be responsible for indirect material costs; and a maintenance department manager may be responsible for repair costs. Committed fixed factory overhead costs that are not affected by production, such as factory rent and depreciation, are usually controlled by upper-level management.

When preparing factory overhead cost estimates for the next period, assumptions must also be made about changes in costs as a result of inflation, technological advances, and policy decisions regarding production standards or objectives. Budgeting factory overhead costs requires careful

analysis of past experience, expected economic conditions, and other pertinent data in order to arrive at the best possible prediction of next period's factory overhead costs.

When determining a standard product cost, the amount representing factory overhead cost is separated into variable and fixed costs. A *variable* cost can be assigned to products over a wide range of activity levels. Although the total variable factory overhead costs will vary in direct proportion with the production level, the variable factory overhead cost per unit will remain constant within the relevant range. The total *fixed* factory overhead cost will remain constant over different activity levels within the relevant range. Fixed factory overhead costs per unit vary inversely; as production expands, fixed factory overhead costs can be spread over more units, so that unit costs decrease. Because of this cost behavior characteristic, the application of a standard fixed factory overhead cost to each product becomes a problem when production levels vary. Standard costing establishes a single standard cost per unit that is applied to products despite fluctuations in production. Consequently, the application of variable factory overhead to products and the ultimate analysis of variances discussed later are very similar to the assignment of direct materials and direct labor to products since all three costs are variable costs. However, the application of fixed factory overhead to products requires a special analysis or variance to accommodate the fact that it is a fixed cost.

Budgets are commonly used in controlling factory overhead costs. Prior to the period in question, a budget that shows anticipated factory overhead costs is prepared. Actual factory overhead costs are later compared with those budgeted as a means of evaluating managerial performance. Two commonly used budgeting approaches are static budgets and flexible budgets.

Static budgets show anticipated costs at *one* level of activity justified on the assumption that production will not materially deviate from the level selected. When the majority of factory overhead costs are unaffected by activity or when productive activity is stable, the static budget would be the appropriate tool. However, such a situation is rare. Also, production levels usually fluctuate in response to fluctuations in customer demand. If a static budget is used and actual production differs from planned production, an accurate cost comparison cannot be made because part of the difference between actual and standard costs is the result of a change in the level of production, which a static budget cannot explain.

Flexible budgets show anticipated costs at different activity levels. This eliminates the problems associated with static budgets in terms of fluctuations in production activity. Actual costs incurred must be compared with budgeted costs that would have been incurred at the same *activity level*. The comparison of actual cost to standard cost at the same activity level is

the only meaningful comparison for performance evaluation purposes and makes flexible budgets a more realistic form of budgeting. Table 24.2 shows an example of a static factory overhead budget. This static budget could be used if the standard hours allowed and actual hours worked were equal to 6,000 hours.

Continuing the example of the Standard Corporation, the standard factory overhead application rate for 20X2 will now be developed on the basis of direct labor hours. Table 24.2 is a static budget (with only one activity level—normal capacity) that was prepared by various department managers in consultation with upper-level management.

Establishing Standards for a Process Cost and Job Order Cost System

The previous section presented an example of standard setting for a very simple process cost system where only one department is used and only one product is produced. In a process cost system, where homogeneous units are mass produced, it is simply a matter of establishing direct materials, direct labor, and factory overhead standards for each of the products that is being manufactured. When more than one department is used in a production process, individual standards should be developed for each department in order to assign accountability to managers at the department level.

TABLE 24.2 Static Budget for 20X2

| | |
|--|------------------------|
| Projected activity level (in direct labor hours) | <u>6,000</u> |
| <i>Variable factory overhead costs:</i> | |
| Indirect materials | \$600 |
| Indirect labor (includes vacation pay) | 3,000 |
| Repairs | 1,200 |
| Power | <u>1,800</u> |
| Total variable factory overhead | <u>\$6,600</u> |
| <i>Fixed factory overhead costs:</i> | |
| Heat and light | \$3,500 |
| Supervision | 25,000 |
| Depreciation on cutting and sewing machines | 1,500 |
| Factory rent | <u>6,000</u> |
| Total fixed factory overhead | <u>\$36,000</u> |
| Total factory overhead | <u><u>\$42,600</u></u> |

In a job order cost system, individual jobs are composed of a single complex unit or a small batch of complex units. These units are custom made and thereby tailored to the specifications of those placing orders. Consequently, standard setting in a job order cost system becomes an enormously time-consuming task of developing custom-made direct material, direct labor, and factory overhead standards before each unique job is started, in order to assign accountability to managers at the job level.

Quality and Quality Costs

The establishment of standard costs must take into consideration a company's policies and objectives in relation to product quality.

At one time, products manufactured in the United States were viewed as the best in the world. However, this view is no longer accepted by consumers; the quality of manufactured products has deteriorated. At the same time, foreign manufacturers have utilized manufacturing and quality control techniques that have improved the quality of their manufactured products. With the increase in demand for foreign manufactured products and the corresponding decline in demand for those made by U.S. firms, greater attention has focused on quality and the costs associated with the production of nonconforming products. Studies of the cost of quality found that the associated costs were high.

Two examples of the cost associated with defective products are rework costs and product liability claims. Defective products also result in potential safety hazards.

Prime examples of excessive rework costs and safety hazards caused by product failure can be found in the automotive industry. Since the Federal Safety Law went into effect in September 1966, millions of automobiles and trucks produced by American and foreign companies have been recalled as a result of design and/or manufacturing defects. One automobile manufacturer reported that their costs associated with quality-related costs *increased* by \$500 million for the first nine months of 2005. Another car manufacturer recalled 500,000 cars to correct a safety defect that could lead to a rear axle and wheel falling off. Auto manufacturers must realize that the time has come for them to slow down their production lines and spend more time and money on improving quality instead of concentrating on quantity.

Definitions of Quality

A product's quality is greatly influenced by market requirements. Some consumer items are manufactured to break down early because of style changes or planned obsolescence, whereas others are influenced not by style but by

the intended use of the product. The quality of any product depends on the interaction of quality of design, quality of conformance to design, and quality of performance.

Quality of design includes adherence to proper specifications, depending on technical requirements (strength, fatigue resistance, life, function, and interchangeability). Quality of conformance to design concerns itself with the original design requirements and the degree to which the manufactured product conforms to design specifications. Performance of a product depends on both the quality of design and the quality of conformance to design. Therefore, if either of the first two elements do not meet the requirements for good quality, a product will offer poor performance.

Distinctions must be made among quality specification, workmanship, and product reliability. Quality specification relates to design quality, whereas workmanship is associated with production quality. Product reliability is based on the probability that a product will operate satisfactorily for a specific period of time under specified conditions of usage.

Zero Defects

Many firms employ a *zero defects* program to eliminate defects in a product line. One method of obtaining zero defects is to provide recognition for individual achievement. People have been conditioned to accept the fact that they are not perfect and are, therefore, susceptible to mistakes.

Human errors are primarily caused by three situations: lack of knowledge, lack of proper facilities, and lack of attention. Lack of knowledge can be corrected by using modern training techniques, and lack of proper facilities can be corrected by periodic plant and equipment surveys. Errors caused by lack of attention are most difficult to detect because they result from improper attitudes held by employees. Improper attitudes can be mitigated by instituting a zero defects program.

Employees can be reconditioned to realize that defects need not happen. A zero defects program challenges the individual to establish personal goals for superior performance and to strive for personal excellence.

It is also important to note that just-in-time production (discussed later) depends on quality. If inventory is kept to a bare minimum, defective products anywhere along the production process might result in a closing down of the production line.

Policies and Objectives of Quality Control

Quality control is defined as a continuous system of feedback necessary for decision making to assure optimum product quality. *Optimum* (the most

favorable degree) is a key word, since the quality control department must assure conditions necessary to manufacture products acceptable to the consumer at the lowest possible cost.

The degree to which a product conforms to established standards is a matter for decision and policy formulation by top management. Quality policy may also be dictated by government (via regulations), recognized trade practices, specific product operating requirements, production economics, consumer demand, and characteristics of the market.

Management may collaborate with several departments within the organization when evaluating policy and making decisions affecting quality. Sales departments may be consulted as to consumer demands and competition; engineers and designers need to relate changes to effects on performance; manufacturing departments must revise costs and solve product problems; purchasing departments must acquaint themselves with the cost and relative availability of raw materials; and quality control departments must be concerned with inspection problems and quality trends.

The primary objective of quality control is to assure a unit of usable product or service at the lowest cost. Quality objectives may be directed either toward maintaining the *status quo* or toward initiating change (i.e., improvement). Objectives aimed at maintaining present conditions imply that current performance is adequate. Present performance levels serve as a basis for developing standards for future production.

Quality standards are commonly set for:

- *Vendors*: Expected levels of defects for purchased materials.
- *Production processes*: Expected levels of defects at various stages of production.
- *Finished goods*: Quality level of finished products.
- *Inspection*: Testing and rework costs.

Decisions as to the type of objectives employed depend on the individual needs of a company. The quality control department has the responsibility for assuring that quality standards are maintained. Quality control departments must make compromises in attempting to satisfy conflicting goals (quality versus the cost of quality).

Quality Costs

The cost of quality (COQ) has been estimated by some experts to represent a significant portion of the cost of production. The COQ is the cost of not producing a quality product or service. These costs include the cost of re-building a product, the cost of repeat service calls, and the cost of rework-

inga produced item. Cost estimates vary, but the typical cost of quality for U.S. companies ranges from 10% to 20% of sales. Borg-Warner estimated that at one time it spent an average of about 20% of sales to correct poor quality. Hewlett-Packard found that the cost of replacing a faulty 2-cent resistor in a computer could exceed the manufacturing cost of that computer if it had to be serviced in the field.

There exists in many manufacturing firms a quality control department that attempts to detect defective products and provide statistical information about the number of defective units produced. However, this information is too often not translated into a dollar cost measure. The cost accounting department rather than the quality control department must be capable of measuring these costs so that they are reflected in the financial performance measure of the manager responsible for them. It would seem that the statistical measures reported by the quality control department would be sufficient to motivate managers to improve quality.

If the cost of quality is to be included in the evaluation of managers, this means it must be measured. The cost of quality, or nonconformance to quality standards, is commonly divided into four groups: prevention costs, appraisal costs, internal failure costs, and external failure costs. The first two costs are incurred because there might be a lack of conformance of products. The last two costs are incurred because a lack of conformance does exist for a product. A definition of each cost and the types of costs within each category are given in Table 24.3.

JUST-IN-TIME PHILOSOPHY AND COST ACCOUNTING

The greater use of automated equipment in the production process has substantially reduced the direct labor content of products. At the same time, fixed or indirect factory overhead costs resulting from the introduction of automated equipment have risen dramatically. This has had two important implications. First, the traditional cost accounting approach of treating direct labor as the factor that “drives” costs and thereby using it as the activity base for allocating indirect factory overhead costs is questionable. In a manufacturing firm that produces multiple products, product costs using labor as the allocation base will not provide correct information about the profit of a product line or the relative profitability of all the products manufactured.

The second implication is that with indirect factory overhead costs rising, a production policy has been adopted by a large segment of U.S. manufacturing to maximize the output produced with labor and equipment. Such a policy spreads indirect manufacturing overhead over more units produced.

TABLE 24.3 Definition of the Types of Quality Costs

-
1. *Prevention costs.* Includes the cost of:
 - a. Overall quality planning and standard setting
 - b. Designing and operating a quality assurance system
 - c. Quality training for employees
 - d. Preventive maintenance on tools and equipment
 - e. Supplier training and evaluation
 - f. Engineering studies to improve quality performance
 2. *Appraisal costs.* Includes the cost of:
 - a. Statistical process control procedures
 - b. Inspection
 - c. Testing
 - d. Quality audits
 3. *Internal failure costs.* Includes the costs incurred before the product leaves the factory for:
 - a. Rework
 - b. Scrap
 - c. Downtime
 4. *External failure costs.* Includes the costs incurred after the product leaves the factory for:
 - a. Warranty repairs
 - b. Handling of customer complaints
 - c. Repacking and freight
 - d. Product liability claims
-

This is not an unsound policy if everything produced in a given period is sold. However, typically this is not the case; any unsold production is inventory. Thus, the production strategy followed to spread indirect manufacturing overhead costs leads to a strategy that builds up inventory.

The policy of attempting to maximize output to spread indirect manufacturing costs was challenged a quarter of a century ago. Instead, the just-in-time (JIT) philosophy is becoming more widely adopted by manufacturing firms involved in repetitive manufacturing processes.¹ In fact, this production process approach was first adopted by Toyota in the 1950s—where it was dubbed the Toyota Production System—and became widely adopted by Japanese manufacturing firms in the 1970s. Adoption in the United States began in the late 1970s, but gained increased attention in the

¹ JIT is also referred to as *lean production* and *time-based competition*. Some large firms that have adopted the JIT philosophy have coined their own term. For example, General Electric calls it “Short Cycle Manufacturing,” Hewlett Packard calls it “Stockless Production” and “Repetitive Manufacturing System,” and IBM calls it “continuous flow manufacture.”

TABLE 24.4 Elements of Manufacturing to Illustrate JIT (in Days)

| | Raw Material | Production Department | | | | Total |
|-----------------|-----------------|-----------------------|------|------|------|-------|
| | | A | B | C | D | |
| Processing time | — | 0.50 | 0.60 | 0.70 | 0.20 | 2.0 |
| Inspection time | 0.15 | 0.20 | 0.15 | 0.20 | 0.30 | 1.0 |
| Moving time | 0.05 | 0.10 | 0.10 | 0.10 | 0.15 | 0.5 |
| Waiting time | — | 0.05 | 0.10 | 0.25 | 0.20 | 0.6 |
| Storage time | 2.00 | 0.00 | 0.00 | 0.00 | 3.00 | 5.0 |

1980s. One of the first adopters in the United States was General Electric in the 1980s.²

The production process described in Table 24.4 will illustrate the reason for the shift in manufacturing philosophy to JIT. There are four production departments, A, B, C, and D, that a product must go through before it is completed. The production process begins with raw materials in Department A and moves sequentially through Department D. Once the product is completed in Department D, it is sent to storage and then shipped to customers.

The elements in this manufacturing process that account for the time between the beginning of the production process for a product and the time it is ready to be shipped to a customer are explained below. This time interval is referred to as the *throughput time* and consists of the following five elements:

1. *Processing time* is the actual time the product is being worked on. In this hypothetical production process, it is the time necessary to process the product in each of the four departments. From Table 24.5, the processing time is 2 days.
2. *Inspection time* is the time spent to inspect the product to make sure it conforms to production standards as it moves from one production department to the next and before it is shipped to customers. Inspection time also includes the time it takes to rework products that are found not to conform to specifications. Note that in addition to inspecting the product as it moves through the production departments, inspection is also required when the raw material is purchased. In this example, inspection time is 1 day.
3. *Moving time* is the time it takes to move the product from one production department to the next and the time to move it to and from storage. For example, when raw materials are received from suppliers, assume

² In 1984, a joint venture was formed between Toyota and General Motors (called New United Motor Manufacturing).

that they are stored before they are delivered to Department A. When Department A has completed processing the product and has inspected it (and reworked it, if necessary), it is transported to Department B. After processing and inspection are completed in Department B, the product is transported to Department C, and so on. The moving time for this hypothetical production process is 0.5 day.

4. *Waiting time* or *queue time* is the time that the product remains in a production department before it is worked on. For example, after the product is transported from Department A, it may not be worked on immediately in Department B. In this example, the waiting time in Department B is estimated to be 0.1 day. For the entire production process, the waiting time is 0.6 day.
5. *Storage time* is the time that raw material, work in process, and finished products remain in storage before they are used by a production department (in the case of raw material and work in process) and they are shipped to customers (in the case of finished products). It is assumed that only raw materials and the finished product are held in storage. The storage time is 5 days in this example.

Looking at the five elements above, all but the first involve the actual production of the product. From a manufacturing production perspective, the first element could be thought of as *value-added time* while the last four elements can be viewed as *nonvalue-added time*. The term nonvalue-added time is used because it refers to the fact that no value is added to the product when it is not worked on. Thus, throughput time can be viewed as follows:

$$\text{Throughput time} = \text{Value-added time} + \text{Nonvalue-added time}$$

or

$$\text{Throughput time} = \text{Processing time} + \text{Nonvalue-added time}$$

Alternatively, nonvalue-added time can be viewed as *waste time* and therefore throughput time can be expressed as:

$$\text{Throughput time} = \text{Value-added time} + \text{Waste time}$$

or

$$\text{Throughput time} = \text{Processing time} + \text{Waste time}$$

In this hypothetical production process, waste time or nonvalue-added time is the sum of inspection time (1 day), moving time (0.5 day), waiting time (0.6 day) and storage time (5 days), or 7.1 days. Value-added or processing time is 2 days. Thus, throughput time is 9.1 days.

Studies of manufacturing firms have found that processing time is a small fraction of throughput time. For example, processing time of less than 10% of throughput time is common in many plants.

The philosophy of JIT is that of identifying the causes of waste time and the implementation of strategies that will minimize throughput time. In the extreme case if all waste time can be eliminated, throughput time will equal processing time.

Strategies for Reducing Waste Time

The following strategies can be pursued to reduce waste time.

Inspection time can be reduced by improving quality. Eliminating inspection time requires a commitment to a program of total quality or zero defects, which was described in the previous section. Not only must there be a commitment to total quality within the company, but a firm must work with its suppliers to ensure that they will deliver raw material that conforms to purchase specifications.

Reducing moving time involves designing the plant layout so that departments are physically close. It also could involve designing the product so that it requires less movement through a production process.

Waiting time (queue time) can be reduced in several ways. The most obvious way is better coordination among production departments. In the extreme case, where if one production department receives a product from another just at the precise time (or “just in time”) it will begin working on the product, waiting time will be zero. A precondition for a dramatic reduction in waiting time is a commitment to total quality because the existence of nonconforming products will prevent a product from moving smoothly and efficiently through the production process. A second way to reduce waiting time is better design of both products and manufacturing equipment to reduce *setup time*. To understand setup time, consider a firm that produces several products and that each production department processes each product. Equipment may have to be modified for each product line. The time required to modify the equipment is what is meant by setup time. To reduce or eliminate setup time, and therefore waiting time, equipment can be purchased that can more easily accommodate more than one product line, or products can be designed so that they can be more easily processed on the same equipment.

Storage time can be reduced in several ways. First, by working with suppliers to ensure that raw materials will be delivered on time and conform to specifications, the need to purchase excess inventory as a safety cushion will be reduced. Second, better coordination between departments will mean less time that work in process must be stored. Finally, a reduction of throughput time itself will mean that fewer finished products will have to be stored in order to satisfy variable demand for the product. If, for example, throughput time is 3 days, the company knows that it can supply its customers in that time period. There is less need for keeping a buffer of finished products because of uncertain or lengthy throughput time.

From the above description it is evident that waste time can also be classified into two components: *waste time due to manufacturing a product* and *waste time due to purchasing raw materials*. This second component consists of (1) the time to inspect raw materials, (2) the time raw materials are stored after being purchased until they are used, and (3) the additional time involved with moving raw materials to storage when they are received and then to the production department, rather than directly to the production department where they are first needed. JIT philosophy that focuses on the first component of waste time is referred to as *JIT manufacturing*; focus on the second component of waste time is referred to as *JIT purchasing*.

VARIANCE ANALYSIS

One of the major purposes of using a standard cost system is to aid management in controlling the costs of production. Standards enable management to make periodic comparisons of actual results with standard (or planned) results. Differences that arise between actual results and planned results are called *variances*. *Variance analysis* is a technique that can be used by a CFO to measure performance, correct inefficiencies, and deal with the “accountability function.” (Cost center managers report to the production supervisor who delegated authority to them.)

Before accountability can be required of managers, responsibility for costs must be clearly defined. Responsibility for costs should be assigned only to the department or cost center having the authority to incur the cost. When authority is delegated by upper-level management to middle- or lower-level managers, they will be held accountable for their performance.

An example using a company called Standard Corporation will be used. The standards for 20X2 established by the Standard Corporation are reproduced in Table 24.5. It is now the end of 20X2 and the following actual cost, production, and revenue data have been accumulated for the Standard Corporation:

| | |
|---|-----------------|
| Direct materials' weighted average purchase price | \$4.90 per yard |
| Direct materials purchased | 4,500 yards |
| Direct materials used | 4,200 yards |
| Direct labor payroll | \$49,725 |
| Direct labor hours worked | 5,850 |
| Total variable factory overhead | \$6,195 |
| Total fixed factory overhead | \$36,300 |
| Units started and completed | 1,800 |
| Units in ending work-in-process inventory (100% direct materials; 60% conversion costs) | 100 |
| Units sold | 1,650 |
| Unit selling price | \$100 |
| Marketing and administrative expenses | \$45,000 |

There were no beginning inventories.

TABLE 24.5 Standards for Standard Corporation

| | |
|--|------------------------------|
| Direct materials price | \$5 per yard |
| Direct materials efficiency | 2 yards/unit |
| Direct labor price | \$8 per direct labor hour |
| Direct labor efficiency | 3 direct labor hours/unit |
| Variable factory overhead application rate | \$1.10 per direct labor hour |
| Fixed factory overhead application rate | \$6 per direct labor hour |
| Expected production at normal capacity | 2,000 units |
| Expected direct labor hours at normal capacity | 6,000 |
| <i>Total standard cost per unit:</i> | |
| Direct materials (2 yards/unit × \$5 per yard) | \$10.00 |
| Direct labor (3 direct labor hours/unit × \$8 per direct labor hour) | 24.00 |
| Factory overhead: | |
| Variable factory overhead (3 direct labor hours/unit × \$1.10 per direct labor hour) | \$3.30 |
| Fixed factory overhead (3 direct labor hours/unit × \$6.00 per direct labor hour) | <u>18.00</u> <u>21.30</u> |
| Total | <u>\$55.30</u> |

Direct Materials Variances

Direct materials variances may be divided into a price variance and an efficiency (quality or usage) variance.

Direct Materials Price Variance

The difference between actual price per unit of direct materials purchased and standard price per unit of direct materials purchased results in the direct materials price variance *per unit*; when multiplied by the actual quantity purchased, the outcome is the *total* direct materials price variance.

This is the preferred method of computing the direct materials price variance because the variances are recorded when purchases are made. Some companies prefer to compute the direct materials price variance when the direct materials are put into production. The obvious disadvantage of this second method is that the variance is not computed until the direct materials are used. However, in recent years the time lag between the initial purchase and use of a material has shortened as more companies are implementing just-in-time inventories procedures, which significantly reduce and in some cases completely eliminate inventories.

During periods of changing prices, the actual direct materials price per unit must be computed by taking a weighted average of all the purchases made during the period under analysis.

Assume that Standard Corporation made four separate purchases during 20X2, each at a different unit purchase price. The weighted average purchase price of \$4.90 per yard was calculated by weighting each individual purchase in yards by its corresponding price per yard. As you can see in Table 24.6, the total purchase price, \$22,050, is divided by the total number of yards purchased, 4,500, yielding the weighted average purchase price per yard of \$4.90.

It is especially important to note that the *actual quantity purchased* is used in the computation of the direct materials price variance instead of the actual quantity *used*, since it is the act of purchasing and not requisitioning that will give rise to a price variance. The equation for the direct materials price variance is:

$$\text{Direct materials price variance} = \left(\frac{\text{Actual unit price} - \text{Standard unit price}}{\text{unit price}} \right) \times \frac{\text{Actual quantity purchased}}{\text{purchased}}$$

Management has very little control over price variances, especially when they result from unexpected price changes, although for some commodities there are risk management techniques/contracts that can be used to eliminate price risk. However, the purchasing department may have some control

TABLE 24.6 Computation of Weighted Average Purchase Price per Unit

| Purchase Number | Quantity Purchased (Yards) | × | Per-Unit Purchase Price | = | Total Purchase Price |
|-----------------|----------------------------|---|-------------------------|---|----------------------|
| 1 | 1,000 | | \$4.70 | | \$4,700 |
| 2 | 900 | | 4.90 | | 4,410 |
| 3 | 1,400 | | 5.00 | | 7,000 |
| 4 | <u>1,200</u> | | 4.95 | | <u>5,940</u> |
| | <u>4,500</u> | | | | <u>\$22,050</u> |

$$\text{Weighted average purchase price per yard} = \frac{\$22,050}{4,500 \text{ yards}} = \$4.90 \text{ per yard}$$

over prices by ordering in economical quantities, which will be determined via quantitative techniques and/or finding suppliers who offer the same quality of goods at lower prices. Very often the needs for the upcoming period are contracted for at a fixed price and are drawn upon as required. Most companies assign the responsibility for price variances to the purchasing department.

The direct materials price variance for the Standard Corporation is:

$$\text{Direct materials price variance} = \left(\begin{array}{c} \text{Actual} \\ \text{unit price} \end{array} - \begin{array}{c} \text{Standard} \\ \text{unit price} \end{array} \right) \times \begin{array}{c} \text{Actual quantity} \\ \text{purchased} \end{array}$$

$$(\$450) \text{ favorable} = (\$4.90 - \$5.00) \times 4,500$$

A favorable price variance (costwise) resulted because Standard Corporation paid \$0.10 less per unit (\$4.90 – \$5.00) than expected for the 4,500 units it purchased. Whenever the actual price is less than the standard price the variance is favorable costwise. Favorable price variances are treated as credits when variances are journalized because they reduce production costs (which are debits). A favorable price variance may be bad or good for the company. For example, if the favorable price variance was achieved by purchasing a lower-quality direct material (than desired by management), the ultimate quality of the final product may be reduced. The reduced product quality may in turn negatively impact on the number of units sold. Direct materials of inferior quality may also have an adverse effect on the efficiency variance. For example, some of the cloth purchased may have to be discarded on the cutting table because of imperfections in the weaving, thereby unnecessarily increasing the amount of direct materials used. Of course, it is much more likely that the favorable price variance is good for the company. For example, the favorable price variance may have resulted

from the purchasing department finding a new supplier who could deliver the required quality of goods at a lower than expected price.

Many companies follow a simple rule: All variances, whether favorable or unfavorable, should be investigated. Other companies subscribe to the *management by exception* principle, which calls for the investigation of only significantly unfavorable variances, which may also be a suboptimal approach. Variance investigation is a complex issue that cannot be solved by blanket rules. Instead, decision theory and statistical quality control techniques are commonly used to determine the best course of action when faced with favorable and/or unfavorable variances.

It should be noted that in the example, for simplicity's sake, variances are computed at the end of the period. In practice, however, direct materials, direct labor, and factory overhead variances are computed throughout the period in order for management to pinpoint and correct any problems at their inception.

Direct Materials Efficiency (Quantity or Usage) Variance

The difference between the actual quantity of direct materials used and the standard quantity allowed, multiplied by the standard price per unit, is equal to the direct materials efficiency variance. The equation for the direct materials efficiency variance is:

$$\text{Direct materials efficiency variance} = \left(\text{Actual quantity used} - \text{Standard quantity allowed} \right) \text{Standard unit price}$$

Standard quantity allowed is the product of the standard quantity of direct materials per unit and the equivalent production:

$$\text{Standard quantity allowed} = \left(\text{Standard quantity per unit} \right) \left(\text{Equivalent production} \right)$$

Note that equivalent production is used in the computation of the standard quantity allowed and not just the units completed during a period. Equivalent production is defined as the sum of units still in process, restated in terms of completed units plus total units actually completed. Although the concept of equivalent production applies mainly to a process cost system described in Chapter 21, it must also be used in a job order cost system to compute the total amount of production for a period.

As a result of using the standard price per unit and not the actual price per unit, the effect of price changes has been eliminated. The direct materials efficiency variance computed can be solely attributed to differences in the quantity of input unaffected by purchasing department price efficiencies or inefficiencies. The production department or cost center that controls the

input of direct materials into the production process is assigned the responsibility for this variance.

We can now calculate the direct materials efficiency variance for the Standard Corporation. First, the standard quantity is computed as follows:

$$\begin{aligned} \text{Standard quantity allowed} &= \left(\begin{array}{c} \text{Standard quantity} \\ \text{per unit} \end{array} \right) \left(\begin{array}{c} \text{Equivalent} \\ \text{production} \end{array} \right) \\ 3,800 \text{ yards} &= (2 \text{ yards / unit})(1,900 \text{ equivalent units}) \end{aligned}$$

where the equivalent production is found as follows:

| | |
|--|-------|
| Units started and completed | 1,800 |
| Units in ending work-in-process inventory (100 × 100% complete with respect to direct materials) | 100 |
| Total equivalent units | 1,900 |

Therefore,

$$\begin{aligned} \text{Direct materials efficiency variance} &= \left(\begin{array}{c} \text{Actual} \\ \text{quantity used} \end{array} - \begin{array}{c} \text{Standard} \\ \text{quantity allowed} \end{array} \right) \text{Standard} \\ &\quad \text{unit price} \\ \$2,000 \text{ unfavorable} &= (4,200 \text{ yards} - 3,800 \text{ yards}) \times \$5 \end{aligned}$$

An unfavorable efficiency variance resulted because the Standard Corporation used 400 yards (4,200 yards – 3,800 yards) of direct materials more than it was allowed in the production of 1,900 equivalent units. Whenever more direct materials are used than allowed, the variance is unfavorable costwise because of the increased direct materials cost of the finished product. An unfavorable direct materials efficiency variance may, for example, be attributed to poor workmanship (the cutter may not be getting the expected number of pieces per yard because he did not properly lay out the patterns) or inferior direct materials (a possibility in this example since the direct materials price variance was favorable). A favorable direct materials efficiency variance may not necessarily be good for a company. For example, the favorable variance may result from the use of fewer direct materials than the standard requires, which might adversely affect the quality of the product. The exact reason for the variance must be determined by management so that corrective action may be taken.

Effect of Efficiency on the Direct Materials Price Variance

The direct materials price variance is computed by multiplying the direct materials price variance per unit by the *actual* quantity purchased. Thus, the actual quantity purchased will impact on the total amount (if any) of the di-

rect materials price variance if the actual quantity purchased does not equal the standard quantity allowed. To remove the effect of efficiency from the price variance, a *pure price variance* could be computed by multiplying the direct materials price variance per unit by the standard quantity allowed. A *combined price-efficiency variance* could be computed by multiplying the direct materials price variance per unit by the difference between the actual quantity purchased and the standard quantity allowed.

A pure price variance and a combined price-efficiency variance for the Standard Corporation will now be computed:

$$\text{Pure direct materials price variance} = \left(\begin{array}{c} \text{Actual} \\ \text{unit price} \end{array} - \begin{array}{c} \text{Standard} \\ \text{unit price} \end{array} \right) \times \begin{array}{c} \text{Standard} \\ \text{quantity allowed} \end{array}$$

$$\$ (380) \text{ favorable} = (\$4.90 - \$5.00) \times 3,800$$

$$\text{Combined price-efficiency variance} = \left(\begin{array}{c} \text{Actual} \\ \text{unit price} \end{array} - \begin{array}{c} \text{Standard} \\ \text{unit price} \end{array} \right) \times \left(\begin{array}{c} \text{Actual} \\ \text{quantity} \\ \text{purchased} \end{array} - \begin{array}{c} \text{Standard} \\ \text{quantity} \\ \text{allowed} \end{array} \right)$$

$$\$ (70) \text{ favorable} = (\$4.90 - \$5.00) \times (4,500 - 3,800)$$

The sum of the pure direct materials price variance and the combined price-efficiency variance equals the previously presented direct materials price variance shown as follows:

| | |
|--------------------------------------|------------------------------------|
| Pure direct materials price variance | \$ (380) Favorable variance |
| Combined price-efficiency variance | <u>(70)</u> Favorable variance |
| Direct materials price variance | <u>\$ (450)</u> Favorable variance |

The benefits derived from dividing the price variance into a pure price and combined price-efficiency variance are very limited. The purchasing department should be held responsible for securing the best price for *all* purchases and not just the standard quantity allowed. It is conceivable that department managers may request this price variance refinement if their bonuses are tied in to these variances. For the purposes of this book, however, the direct materials price variance will not be divided into the two subvariances.

Direct Labor Variances

Direct labor variances may be divided into price variance and efficiency variance.

Direct Labor Price (Rate) Variance

The difference between the actual hourly wage rate and the standard hourly wage rate results in the *direct labor price variance per hour*; when multiplied by the actual direct labor hours worked, the outcome is the *total direct labor price variance*. The actual number of direct labor hours worked as opposed to the standard direct labor hours allowed is used because we are analyzing the cost difference between the payroll that should have been incurred and the actual payroll that was incurred. Both payrolls are based on the actual number of direct labor hours worked. The equation for the direct labor price variance is:

$$\text{Direct labor price variance} = \left(\begin{array}{c} \text{Actual hourly} \\ \text{wage rate} \end{array} - \begin{array}{c} \text{Standard hourly} \\ \text{wage rate} \end{array} \right) \times \begin{array}{c} \text{Actual number of direct} \\ \text{labor hours worked} \end{array}$$

The supervisor of the department or cost center where the work is performed is held accountable for a direct labor price variance. For example, if workers who are paid \$10 per direct labor hour are incorrectly assigned to work that should have been performed by workers who are paid \$8 per direct labor hour, an unfavorable price variance will result, indicating a misuse of the company's labor resources. Price variances that result from external factors are usually beyond the control of management. For example, if the government establishes a new minimum wage, a company will have to raise the wages of those employees who are currently being paid the old minimum wage. This type of unfavorable price variance can be avoided in the future by simply adjusting upward the standard price per direct labor hour.

The direct labor price variance for the Standard Corporation will now be computed. The actual direct labor rate per hour was not given but may be computed by dividing the actual direct labor payroll by the actual direct labor hours worked:

$$\$49,725 / 5,850 \text{ direct labor hours} = \$8.50 \text{ per direct labor hour}$$

The actual direct labor rate per hour does not represent one employee's wage rate but is the weighted average wage rate for all employees.

$$\text{Direct labor price variance} = \left(\begin{array}{c} \text{Actual hourly} \\ \text{wage rate} \end{array} - \begin{array}{c} \text{Standard hourly} \\ \text{wage rate} \end{array} \right) \times \begin{array}{c} \text{Actual number of direct} \\ \text{labor hours worked} \end{array}$$

$$\$2,925 \text{ unfavorable} = (\$8.50 - \$8.00) \times 5,850$$

An unfavorable price variance resulted because Standard Corporation paid an average of \$0.50 more per direct labor hour (\$8.50 - \$8.00) for

the 5,850 direct labor hours that were actually worked. If wage rates did not unexpectedly change, then it can be assumed that the unfavorable price variance probably developed because workers were not properly assigned to jobs.

Direct Labor Efficiency Variance

The difference between the actual direct labor hours worked and the standard direct labor hours allowed, multiplied by the standard hourly wage rate, equals the *direct labor efficiency variance*.

Standard direct labor hours allowed is equal to the standard number of direct labor hours per unit multiplied by equivalent production. As a result of using the standard wage rate per direct labor hour, the effect of price changes has been eliminated. The direct labor efficiency variance can be solely attributed to workers' efficiency or inefficiency. The equation for the direct labor efficiency variance is

$$\text{Direct labor efficiency variance} = \left(\begin{array}{cc} \text{Actual direct} & \text{Standard direct} \\ \text{labor hours} & \text{labor hours} \\ \text{worked} & \text{allowed} \end{array} \right) \times \begin{array}{c} \text{Standard direct} \\ \text{labor hourly} \\ \text{wage rate} \end{array}$$

The supervisors of the department or cost center in which the work is performed are accountable for direct labor efficiency variances in that it is their responsibility to oversee production and exercise tight control over the amount of direct labor hours worked. The direct labor efficiency variance for Standard Corporation will now be computed. First compute standard direct labor hours allowed:

$$\begin{aligned} \text{Standard direct} &= \text{Standard number of direct} \times \text{Equivalent} \\ \text{labor hours allowed} &= \text{labor hours per unit} \times \text{production} \\ 5,580 \text{ direct} &= 3 \text{ direct labor} \times 1,860 \text{ equivalent} \\ \text{labor hours} &= \text{hours/unit} \times \text{production} \end{aligned}$$

where the equivalent production is found as follows:

| | |
|---|--------------|
| Units started and completed | 1,800 |
| Units in ending work-in-process inventory (100 × 60% complete with respect to direct labor) | <u>60</u> |
| Total equivalent units | <u>1,860</u> |

Then,

$$\text{Direct labor efficiency variance} = \left(\begin{array}{c} \text{Actual direct} \\ \text{labor hours} \\ \text{worked} \end{array} - \begin{array}{c} \text{Standard direct} \\ \text{labor hours} \\ \text{allowed} \end{array} \right) \times \begin{array}{c} \text{Standard direct} \\ \text{labor hourly} \\ \text{wage rate} \end{array}$$

$$\$2,160 \text{ unfavorable} = (5,850 - 5,580) \times \$8$$

An unfavorable efficiency variance resulted because Standard Corporation used 270 direct labor hours (5,850 actual direct labor hours – 5,580 standard direct labor hours) more than the standard direct labor hours allowed in the production of 1,860 equivalent units. Whenever more direct labor hours are used than are allowed, the variance is unfavorable because of the increased direct labor cost of the finished product. An unfavorable direct labor efficiency variance may indicate, for example, that the workers were not as productive as they should have been (e.g., took long breaks, slept on the job, etc.) or that more time was required to cut and sew because of the poor quality of the direct materials. (Remember the possible link to the favorable direct materials price variance.)

In variance analysis, management must compare the costs of investigation against the benefits of investigation before any decision is made to identify and correct the cause of the variance.

One important point that must always be considered is that the standards themselves may be incorrect. Standards are not “chiseled in stone;” they should be periodically reviewed to determine if they are still realistic in light of the current production environment. If standards are incorrect they should be reevaluated and replaced by new standards. If standards are changed too often, however, the effectiveness of a standard cost system is diminished.

Factory Overhead Variances

The control of factory overhead costs under standard costing is similar to the control of direct materials and direct labor costs, already discussed in this chapter. Predetermined standard costs are compared with actual costs as a means of evaluating performance. However, although the basic concept is similar, the specific procedures used to compute and to apply standard factory overhead costs and to analyze factory overhead variances are quite different.

A static budget was prepared for Standard Corporation (see Table 24.2) that could be used if the standard direct labor hours allowed and actual direct labor hours worked were equal to 6,000. Note that direct labor hours will be used as the base to apply overhead in these illustrations. If other bases were used (i.e., machine hours, units, etc.) they would be inserted in place of direct labor hours. Since this was not the case for Standard Corporation, a flexible budget must be developed. Table 24.7 shows a flexible budget for Standard

TABLE 24.7 Standard Corporation; Flexible Budget, for 20X2

| | (1) Allowed | (2) Actual | (3) Normal |
|--|--------------------------|--------------------------|-----------------|
| Direct labor hours | <u>5,580</u> | <u>5,850</u> | <u>6,000</u> |
| Variable factory overhead costs: | | | |
| Indirect materials (\$0.10 per direct labor hour) ^a | \$558 ^e | \$585 ⁱ | \$600 |
| Indirect labor (\$0.50 per direct labor hour) ^b | 2,790 ^f | 2,925 ^j | 3,000 |
| Repairs (\$0.20 per direct labor hour) ^c | 1,116 ^g | 1,170 ^k | 1,200 |
| Power (\$0.30 per direct labor hour) ^d | <u>1,674^h</u> | <u>1,755^l</u> | <u>1,800</u> |
| Total variable factory overhead costs | <u>\$6,138</u> | <u>\$6,435</u> | <u>\$6,600</u> |
| Fixed factory overhead costs: | | | |
| Heat and light | \$3,500 | \$3,500 | \$3,500 |
| Supervision | 25,000 | 25,000 | 25,000 |
| Depreciation on cutting and sewing machines | 1,500 | 1,500 | 1,500 |
| Factory rent | <u>6,000</u> | <u>6,000</u> | <u>6,000</u> |
| Total fixed factory overhead costs | <u>\$36,000</u> | <u>\$36,000</u> | <u>\$36,000</u> |
| Total factory overhead costs | <u>42,138</u> | <u>\$42,435</u> | <u>\$42,600</u> |

Notes: The variable rate per hour is based on normal capacity of 6,000 direct labor hours. The fixed costs do not change because production activity is within the relevant range of 3,000 to 6,000 direct labor hours.

Computations:

$$^a \text{ \$600/6,000} = \$0.10 \text{ per direct labor hour}$$

$$^b \text{ \$3,000/6,000} = 0.50$$

$$^c \text{ \$1,200/6,000} = 0.20$$

$$^d \text{ \$1,800/6,000} = \underline{0.30}$$

$$\text{Total variable} \quad \underline{\underline{\$1.10}}$$

$$^e \text{ \$0.10} \times 5,580 \text{ direct labor hours}$$

$$^f \text{ \$0.50} \times 5,580 \text{ direct labor hours}$$

$$^g \text{ \$0.20} \times 5,580 \text{ direct labor hours}$$

$$^h \text{ \$0.30} \times 5,580 \text{ direct labor hours}$$

$$^i \text{ \$0.10} \times 5,850 \text{ direct labor hours}$$

$$^j \text{ \$0.50} \times 5,850 \text{ direct labor hours}$$

$$^k \text{ \$0.20} \times 5,850 \text{ direct labor hours}$$

$$^l \text{ \$0.30} \times 5,850 \text{ direct labor hours}$$

Corporation for 20X2. Three difference production levels are shown—standard direct labor hours allowed (5,580), actual direct labor hours (5,850), and normal capacity direct labor hours (6,000). Other production levels should be shown if they have informational value to management.

The analysis of factory overhead variances requires more detail than the variances analysis for direct costs (materials and labor). A volume variance must be considered, in addition to the price and efficiency variances that were computed when the direct costs were analyzed. Different techniques have been developed over the years to compute factory overhead variances. The three most commonly used methods will be presented.

One-Factor Analysis of Factory Overhead Variance

The difference between actual factory overhead and standard factory overhead applied to production equals the one-factor analysis of factory overhead variances. Standard factory overhead is applied to production by multiplying the standard hours allowed by the standard factory overhead application rate. Note that this is a departure from how factory overhead is applied under a normal cost system, where it is applied by multiplying the standard factory overhead application rate by the actual hours incurred instead of by the standard hours allowed. As utilized in a standard cost system, the equation for the one-factor analysis of factory overhead variance is

$$\text{Overall factory overhead variance} = \text{Actual factory overhead} - \text{Applied factory overhead}$$

where

$$\text{Applied factory overhead} = \text{Standard direct labor hours allowed} \times \text{Standard factory overhead application rate}$$

Table 24.8 shows the actual factory overhead for the Standard Corporation for 20X2.

The one-factor analysis of factory overhead variance for the Standard Corporation is computed as follows:

One-factor analysis of factory overhead variance method:

$$\begin{aligned} \text{Overall factory overhead variance} &= \text{Actual factory overhead} - \text{Applied factory overhead} \\ \$2,877 \text{ Unfavorable} &= \$42,495 - \$39,618^* \end{aligned}$$

* 5,580 standard direct labor hours allowed \times \$7.10 per direct labor hour

TABLE 24.8 Standard Corporation, Actual Factory Overhead for 20X2

| | |
|---|------------------------|
| <i>Variable factory overhead costs:</i> | |
| Direct materials | \$790 |
| Indirect labor | 3,050 |
| Repairs | 600 |
| Power | <u>1,755</u> |
| Total variable factory overhead costs | <u>\$6,195</u> |
| <i>Fixed factory overhead costs:</i> | |
| Heat and light | \$3,800 |
| Supervision | 25,000 |
| Depreciation on cutting and sewing machines | 1,500 |
| Factory rent | <u>6,000</u> |
| Total fixed factory overhead costs | <u>\$36,300</u> |
| Total factory overhead costs | <u><u>\$42,495</u></u> |

An unfavorable variance resulted because the Standard Corporation paid more for factory overhead than it applied to production. Note that if actual factory overhead were erroneously compared to the static budget of \$42,600 (Table 24.2), a \$105 favorable variance (\$42,495 – \$42,600) would have resulted. This would mislead management into thinking that factory overhead costs were reduced instead of increased. A static budget should be used in analyzing factory overhead variances only when the actual direct labor hours worked coincide with the direct labor hours at normal capacity (i.e., actual production equals denominator production). An overall factory overhead variance will occur when actual factory overhead costs are greater or less than applied factory overhead costs. The one-factor analysis technique is limited in its usefulness because although it shows that a variance exists, it does not help in pinpointing the possible causes.

Two-Factor Analysis of Factory Overhead Variances

Under the two-factor analysis of factory overhead variances, the one-factor factory overhead variance is divided into a budget (controllable) variance and a production volume (denominator or idle capacity) variance.

Budget (Controllable) Variance The difference between actual factory overhead and budgeted factory overhead on the basis of *standard* direct labor

hours allowed equals the budget variance. The equation for the budget variance is

$$\text{Budget (controllable)} = \text{Actual factory overhead} - \text{Budgeted factory overhead at standard direct labor hours allowed}$$

where budgeted factory overhead at standard direct labor hours allowed equals variable factory overhead (standard direct labor hours \times standard variable factory overhead application rate) plus fixed (budgeted) factory overhead.

A variance occurs if a company actually spends more or less on factory overhead than expected and/or uses more or less than the number of direct labor hours allowed. The usefulness of this variance is also limited because management is unable to ascertain whether the variance was due to spending or to efficiency. This variance is also called *controllable variance* because it is believed that the manager or supervisor has some control over this combined (spending and efficiency) variance.

Budget (controllable) variance for Standard Corporation:

$$\begin{array}{r} \text{Budget (controllable)} \\ \text{variance} \end{array} = \begin{array}{r} \text{Actual factory} \\ \text{overhead} \end{array} - \begin{array}{r} \text{Budget at standard direct} \\ \text{labor hours allowed} \end{array}$$

$$\begin{array}{r} \$357 \\ \text{unfavorable} \end{array} = \begin{array}{r} \$42,495 \\ \text{(Table 24.8)} \end{array} - \begin{array}{r} \$42,138 \\ \text{(Table 24.7, column 1)} \end{array}$$

An unfavorable budget variance resulted because actual factory overhead costs exceeded budgeted factory overhead costs based on the level of production actually achieved. An item-by-item analysis can be made to pinpoint which factory overhead costs were responsible for the \$357 unfavorable budget variance. As was stated earlier, the term *fixed factory overhead* means only that an item does not change as productive activity changes; however, the cost of a fixed factory overhead item can and, in all likelihood, will change in response to factors other than production. For example, the cost of heating the factory may have increased as a result of either a colder than expected winter or changes in the cost of heating fuel.

Production Volume (Denominator or Idle Capacity) Variance The difference between the denominator activity level (usually normal capacity) used to establish the standard fixed factory overhead application rate and standard direct labor hours allowed, multiplied by the standard fixed factory overhead application rate equals the production volume variance. The equation for the production volume variance is:

$$\text{Production volume (denominator or idle capacity) variance} = \left(\begin{array}{cc} \text{Denominator} & \text{Standard} \\ \text{direct labor} & \text{direct labor} \\ \text{hours} & \text{hours allowed} \end{array} \right) \times \text{Standard fixed factory overhead application rate}$$

A production volume variance relates only to fixed factory overhead because, in order to determine a product's cost, fixed factory overhead is applied to production as if it were a variable cost. Total fixed costs, by definition, do not change as productive activity changes and will remain constant throughout the relevant range. Total fixed costs can change during a period only if the price of an individual item changes. For example, factory rent may change during the period if the lease expires and the landlord increases rent beyond what was expected. The increase in rent did not result from a change in productive activity but from a change in price. The increase in rent would be reflected in the budget variance where actual fixed factory overhead is compared to budgeted fixed factory overhead.

When the standard labor hours allowed equals the normal capacity direct labor hours, fixed factory overhead applied will equal budgeted fixed factory overhead. This variance is also called the denominator variance because the variance is the result of production at an activity level different from that used in the denominator to calculate the fixed factory overhead application rate. If production falls below (or rises above) the denominator level used in determining the fixed factory overhead application rate, fixed factory overhead costs are being underabsorbed (or overabsorbed). The idle capacity variance is another name for this variance because it deals with the utilization of the plant and the effect of such utilization on the factory overhead cost of the finished product.

The production volume variance is unfavorable when the standard direct labor hours allowed are less than the normal capacity direct labor hours because the plant was underutilized. A favorable production volume variance occurs when standard direct labor hours allowed are greater than normal capacity direct labor hours because better than expected utilization was made of the plant facilities.

Note that the production volume variance is not affected by actual factory overhead costs. Upper-level management is held accountable for a production volume variance since its actions influence the level of sales and corresponding amount of production for the period, which ultimately determines the number of standard direct labor hours allowed for the period.

Production volume (denominator or idle capacity) variance for Standard Corporation:

$$\begin{aligned} \text{Production volume variance} &= \left(\frac{\text{Denominator direct labor hours} - \text{Standard direct labor hours allowed}}{\text{Denominator direct labor hours}} \right) \times \text{Standard fixed factory overhead application rate} \\ \$2,520 \text{ unfavorable} &= \left(\frac{6,000 \text{ direct labor hours} - 5,580 \text{ direct labor hours}}{6,000 \text{ direct labor hours}} \right) \times \$6.00 \end{aligned}$$

An unfavorable production volume variance resulted because the actual equivalent production (for direct labor) was only 1,860 equivalent units and the fixed factory overhead application rate was on an estimated production of 2,000 units.

The budget variance combined with the production volume variance should equal the same unfavorable \$2,877 overall variance that resulted from the one-factor analysis of factory overhead variances, as follows:

| | |
|--|--------------------------|
| Budget variance | \$357 unfavorable |
| Production volume variance | <u>2,520</u> unfavorable |
| One-factor analysis of factory overhead variance | <u>\$2,877</u> |

Three-Factor Analysis of Factory Overhead Variances

Under the three-factor analysis of factory overhead variances, the budgeted variance is divided into its two component variances: a price (spending) variance and an efficiency variance. The production volume variance remains unchanged.

Price (Spending) Variance The difference between actual factory overhead and budgeted factory overhead on the basis of *actual* direct labor hours worked equals the price variance. The equation is

$$\text{Price (spending) variance} = \frac{\text{Actual factory overhead} - \text{Budgeted factory overhead at actual direct labor hours worked}}{\text{Actual direct labor hours worked}}$$

where budgeted factory overhead at actual direct labor hours worked = variable factory overhead (actual direct labor hours worked \times standard variable factory overhead application rate) plus fixed (budgeted) factory overhead.

Note that the only difference between the computation of the budget variance and the price variance is that budgeted factory overhead at standard direct labor hours allowed is used to compute the budget variance whereas budgeted factory overhead at actual direct labor hours worked is used to compute the price variance.

The price variance is also known as the spending variance because in many situations the variance results from price changes (as in direct materials and direct labor price variances) and from temporary changes in operating conditions (which do not affect the direct material and direct labor price variances). For example, in the Standard Corporation one of the variable factory overhead costs is power. The factory overhead price variance could result from an unexpected price increase in electricity during the period. This would result in a “pure” price variance (as in direct materials and direct labor price variances). However, the factory overhead price variance could also have partially or completely resulted from a temporary change in the manufacturing process. If more machine hours are needed to do the same job, then more electricity would be required to run the equipment, causing a factory overhead price variance. The factory overhead price variance would then be a function of operating conditions and not price. For this reason, some accountants prefer to use the term *factory overhead spending* instead of price variance, which would imply that the company spent more or less on factory overhead than anticipated (as a result of temporary changes in either operating conditions or prices).

A factory overhead price or spending variance is usually not controllable by management if it results from external forces (e.g., the power company increases its rates); however, it is controllable by management if the variance is the result of internal factors (e.g., changes in operating conditions).

Price (spending) variance for Standard Corporation:

$$\begin{aligned} \text{Price} &= \frac{\text{Actual factory overhead}}{\text{direct labor hours allowed}} - \frac{\text{Budgeted factory overhead}}{\text{direct labor hours allowed}} \\ \$60 &= \frac{\$42,495}{\text{(Table 24.8)}} - \frac{\$42,435}{\text{(Table 24.7, column 2)}} \\ \text{unfavorable} & \end{aligned}$$

An unfavorable spending variance resulted because actual factory overhead costs incurred exceeded budgeted costs on the basis of actual hours worked.

Efficiency Variance The difference between actual direct labor hours worked and standard direct labor hours allowed multiplied by the standard variable factory overhead application rate equals the efficiency variance. The equation for the efficiency variance is

$$\text{Efficiency variance} = \left(\frac{\text{Actual direct labor hours worked} - \text{Standard direct labor hours allowed}}{\text{Standard variable factory overhead application rate}} \right) \times \text{Standard variable factory overhead application rate}$$

A variance will occur if workers are more or less efficient than planned. If workers are inefficient, actual direct labor hours worked will exceed standard direct labor hours allowed and thus more variable factory overhead will be incurred in the manufacture of finished units than was planned.

In the previous formulas given for the analysis of factory overhead, it was assumed that factory overhead was applied using direct labor hours. This analysis does not change if another denominator base (direct labor cost, direct material cost, machine hours, units of production, etc.) is used. For example, if direct labor cost were used as the denominator to determine the standard factory overhead application rate, then the equation for the efficiency variance would appear as

$$\text{Efficiency variance} = \left(\frac{\text{Actual direct labor cost} - \text{Standard direct labor cost}}{\text{cost}} \right) \times \frac{\text{Standard variable factory overhead application rate}}{\text{(percentage of direct labor cost)}}$$

The efficiency variance for Standard Corporation is:

$$\begin{aligned} \text{Efficiency variance} &= \left(\frac{\text{Actual direct labor hours worked} - \text{Standard direct labor hours allowed}}{\text{cost}} \right) \times \frac{\text{Standard variable factory overhead application rate}}{\text{cost}} \\ \$297 \text{ unfavorable} &= \left(\frac{5,850 \text{ direct labor hours} - 5,580 \text{ direct labor hours}}{\text{cost}} \right) \times \frac{\$1.10 \text{ per direct labor hour}}{\text{cost}} \end{aligned}$$

An unfavorable efficiency variance resulted because the actual hours worked exceeded the standard hours allowed.

Production Volume Variance The production volume variance (\$2,520 unfavorable) is computed the same as in the two-factor analysis of factory overhead variances method. The price variance combined with the efficiency variance equals the same unfavorable \$357 budget variance that resulted from the two-factor analysis of factory overhead variance, as follows:

| | |
|---------------------|---------------------------------|
| Price variance | \$60 unfavorable |
| Efficiency variance | <u>297 unfavorable</u> |
| Budget variance | <u><u>\$357 unfavorable</u></u> |

DISPOSITION OF ALL VARIANCES

The pricing of all inventories (raw materials, work-in-process, and finished goods) is a major concern of cost accountants because of its influence on

the reporting of income. When standard costing is used, a decision must be made as to whether to price inventories at standard cost or at actual cost. Disposition of variances will differ according to which inventory costing basis is used. If inventory is to be shown at standard costs, the variances will simply be charged off as a period cost. If inventory is to be shown at actual costs, the variances will be prorated among work-in-process inventory, finished goods inventory, and cost of goods sold so as to *approximate* actual costs. In such cases, variances are treated as product costs.

The criteria generally used to determine which method of disposition to use are (1) the characteristics of the standards used, (2) the ability to keep actual costs close to standard costs, and (3) the methods of costing the inventories for external financial reporting.

Under the first criterion, the determination of standard costs and amounts per unit are important. When standard costs are based on attainable standards rather than either fixed or ideal standards, there tends to be less variation between actual and standard costs. When standards are kept up to date (criterion 2), variances are kept within bounds and the variances will generally be treated as period costs. It is reasonable to assume that if standard costs closely resemble actual costs, no further adjustment is necessary. For external financial statement purposes (criterion 3), inventories and cost of goods sold must be reported at actual cost, which is defined as the actual value given up or actual service rendered to acquire or manufacture products. Generally, variances appear on the income statement in one of three places: (1) they may be shown as a separate deduction (if unfavorable) or addition (if favorable) to gross profit; (2) the variances may be a direct adjustment to cost of goods sold; or (3) the amount of each variance may be prorated among the cost of goods sold, materials inventory, work-in-process inventory, and finished goods inventory.

The first method gives separate recognition to the variances by treating them as period costs. Advocates of this method believe that variances are a result of either production efficiencies or inefficiencies and should not be included in product costs.

Under the second method, variances are also considered period costs. However, the variances are buried in the cost of goods sold figure and therefore not highlighted on the income statement. Many accountants are of the opinion that gross profit will be severely distorted under this method if the variances are large relative to the total cost of goods manufactured.

The third and final method of presentation is used by those who believe that financial statements should be shown at actual cost rather than at standard cost. Variances are allocated to inventories and the cost of goods sold so that these accounts will reflect actual costs as nearly as possible. Gener-

ally accepted accounting principles require the use of this method for external financial statements.

For practical purposes, there are two exceptions to the general rules of variance disposition:

1. Immaterial or insignificant variances may be treated as period costs (by a direct adjustment to cost of goods sold).
2. If end-of-period inventories are immaterial or insignificant, variances may also be treated as period costs (by a direct adjustment to cost of goods sold).

BOTTOM LINE

- Standard costs provide management with goals to attain and bases for comparison with actual results.
- Standard costing serves basically the same purpose as a budget. However, standard costing is concerned with cost *per unit* while budgets generally provide cost goals on a *total cost* basis.
- Standard costs are also known as “planned costs,” “predicted costs,” “scheduled costs,” and “specification costs.”
- The setting of standards for direct labor, direct materials, and factory overhead is an important part of any standard cost system.
- Direct materials cost standards may be divided into price and efficiency standards. Direct materials price standards are the unit prices at which direct materials should be purchased. Direct materials efficiency standards are predetermined specifications of the quantity of direct materials that should go into the production of one finished unit.
- Direct labor standards may be divided into price and efficiency standards. Direct labor price standards are average predetermined wage rates for a period. Direct labor efficiency standards are predetermined performance standards in terms of the amount of direct labor hours that should go into the production of one finished unit.
- When a company introduces a new process or product, the level of output per hour will be affected by the learning process. As workers become more familiar with the procedure, output will increase with a resultant direct labor cost per unit decrease. Before determining standards or evaluating present and future costs, management should compute the learning curve effect on direct labor cost.
- The concept of standard setting for factory overhead is similar to standard setting for direct materials and direct labor. The major difference

is that factory overhead cost must be divided into variable and fixed costs.

- An integral part of establishing standards is the development of policies and objectives in relation to product quality. Product quality depends on the interaction of quality of design, quality of conformance to design, and quality of performance.
- Zero defects is a program designed to eliminate defects and thereby improve product quality.
- A quality control program is a continuous system of feedback necessary for decision making to assure optimum product quality. Quality standards are commonly set for vendors, production processes, finished goods, and inspection.
- The cost of quality, or nonconformance to quality standards, is commonly divided into prevention costs, appraisal costs, internal failure costs, and external failure costs.
- The just-in-time philosophy views elements that drive manufacturing costs as: processing time, inspection time, moving time, waiting time, and storage time.
- The time between the beginning of the production process and the time the product is ready to be shipped to a customer is referred to as throughput time.
- Processing time is viewed as value-added time while the other four elements are viewed as waste time or nonvalue-added time.
- The objective in JIT is to eliminate waste time.
- One of the major reasons for using a standard cost system is to aid management in controlling production.
- Variance analysis is a means of determining the effectiveness of controls over production, of measuring performance, and of correcting inefficiencies.
- Direct materials variances may be divided into price and efficiency variances.
- The direct materials price variance is the difference between actual price per unit and standard price per unit of direct materials purchased.
- The direct materials efficiency variance is the difference between actual quantity of direct materials used and the standard quantity allowed multiplied by the standard price per unit.
- Direct labor variances may be divided into price and efficiency variances.
- The direct labor price variance is the difference between the actual wage and the standard wage per direct labor hour multiplied by the actual direct labor hours worked.

- The direct labor efficiency variance is the difference between the actual direct labor hours worked and the standard direct labor hours allowed multiplied by the standard direct labor wage rate.
- Factory overhead variances are commonly computed under the following three methods: one-factor analysis of factory overhead variance, two-factor analysis of factory overhead variance, and three-factor analysis of factory overhead variance.

Direct and Absorption Costing

AGENDA

- Item 1* Determine the cost of manufactured products using either direct or absorption costing.
- Item 2* Compare the use of direct costing and absorption costing in the cost of goods manufactured statement, income statement, and balance sheet.
- Item 3* Identify the principal advantages of direct costing with respect to operations planning, cost-volume-profit analysis, break-even analysis, management decision making, product pricing, and management control.
- Item 4* Identify the principal disadvantages of direct costing such as its restriction from use in external financial statements and the difficulty of accurately separating costs into their variable and fixed components.

The cost of manufactured products is generally based on either *absorption costing* (the full costing concept) or *direct costing* (the variable costing concept). In the preceding chapters absorption costing has been presented in detail, since it is more widely used than direct costing. In this chapter, the concept of direct costing will be defined and illustrated. In addition, the advantages and disadvantages will be discussed, and a comparison of direct costing with absorption costing is included.

MEANING OF DIRECT COSTING

Under absorption costing, sometimes called *full costing* or *conventional costing*, all factory overhead costs, both variable and fixed, are treated as product costs. Under direct costing, only factory overhead costs that vary with volume are charged to products. That is, only the costs of direct materials, direct labor, and variable factory overhead are included in inventory. The concept of direct costing considers only the costs of direct materials, direct labor, and variable factory overhead to be product costs.

Fixed factory overhead under direct costing is not included in inventory. The concept of direct costing considers fixed factory overhead to be a period cost. In direct costing, fixed costs are differentiated from variable costs not only in internal reports but in the various cost accounts as well.

The use of direct costing is more suitable for many types of management's planning, control, and decision-making needs. Since profit under direct costing moves in the same direction as sales volume, the operating statements can be more readily understood by the CFO, general management, marketing and production managers, and the various departmental supervisors. Direct costing is useful in evaluating performance.

DIRECT COSTING VERSUS ABSORPTION COSTING

The principal point of difference between the two costing methods is in the treatment of fixed factory overhead costs. Absorption cost proponents contend that all factory costs, whether variable or fixed, are part of the cost of production and should be included in the computation of unit product costs. They argue that production cannot take place without incurring fixed factory overhead.

The conterargument made by proponents of direct costing is that product costs should be related to the volume of production. They maintain that fixed factory overhead costs will be incurred even if no production takes place. Direct cost advocates contend that fixed factory overhead is, in substance, a period cost related to time, has no future benefit, and is therefore not a cost that should be absorbed in inventory.

A number of other arguments are voiced by absorption costers and direct costers, but the single most important argument advanced by each group has been presented. Both techniques have merit and therefore both will be covered. It should be noted that for external financial reporting, absorption costing must be used, whereas for internal reporting, management prefers direct costing because its cost behavior orientation is the single most important element in planning, control, and decision making.

In summary, absorption costing charges *all* costs to production except those applicable to selling, general, and administrative costs. Therefore, the cost of goods manufactured includes factory depreciation, factory rent, factory insurance, factory property taxes, and all other fixed factory overhead costs in addition to direct materials, direct labor, and variable factory overhead. Some part of fixed factory overhead is carried forward in both the work-in-process and finished goods inventories until the product is completed and sold.

In contrast, in direct costing fixed factory overhead is *not* carried forward because it is not considered a product cost. It is classified as a period cost and charged against revenue in the period of incurrence.

The major differences between the financial statements prepared under direct and absorption costing are presented below.

Cost of Goods Manufactured Statement

The example of the Standard Corporation in Chapter 24 will be continued in this chapter. Relevant data from Chapter 24 for the Standard Corporation is reproduced in Table 25.1.

TABLE 25.1 Standard Corporation Data for 20X2

| | | | |
|--|--|---------------|--------------|
| <i>Standard unit cost:</i> | | | |
| Direct materials | | \$10.00 | |
| Direct labor | | 24.00 | |
| Factory overhead: | | | |
| Variable | | 3.30 | |
| Fixed | | <u>18.00</u> | |
| Total standard unit cost | | | \$55.30 |
| Budgeted fixed factory overhead | | | \$36,000 |
| <i>Standard costs put into production:</i> | | | |
| Direct materials | | | \$19,000 |
| Direct labor | | | \$44,640 |
| Factory overhead: | | | |
| Variable ($\$1.10 \times 5,580$) | | \$6,138 | |
| Fixed ($\$6.00 \times 5,580$) | | <u>33,480</u> | \$39,618 |
| <i>Ending work-in-process inventory (100 units):</i> | | | |
| Direct materials | | \$ 1,000 | |
| Direct labor | | 1,440 | |
| Factory overhead: | | | |
| Variable ($100 \times 60\% \times \$3.30$) | | \$198 | |
| Fixed ($100 \times 60\% \times \$18.00$) | | <u>1,080</u> | <u>1,278</u> |
| | | | \$ 3,718 |

TABLE 25.1 (Continued)

| | | |
|---|--------------|------------------|
| <i>Units in finished goods inventory:</i> | | |
| Units started and completed | 1,800 | |
| Units sold | <u>1,650</u> | 150 |
| <i>Variances:</i> | | |
| Direct materials price | | \$(450) F |
| Direct materials efficiency | | 2,000 U |
| Direct labor price | | 2,925 U |
| Direct labor efficiency | | 2,160 U |
| <i>Factory overhead (3-variance method):</i> | | |
| Price | | 60 U |
| Efficiency | | 297 U |
| Production volume | | <u>2,520 U</u> |
| Total | | <u>\$9,512 U</u> |
| Marketing and administrative expense (assume \$20,000 are fixed costs) | | \$45,000 |
| Sales (1,650 × \$100) | | \$165,000 |

F = Favorable variance; U = Unfavorable variance.

There were no opening inventories.

Assume in this chapter that the variances are not prorated and are instead charged to cost of goods sold.

Ignore income taxes.

For simplicity, it is assumed that the variances for the Standard Corporation are immaterial and therefore not prorated. The variances are treated as a direct adjustment to the cost of goods sold figure on the income statement.

The cost of goods manufactured statement for the Standard Corporation is shown under the absorption costing concept in Table 25.2, and under the direct costing concept in Table 25.3.

The difference between the cost of goods manufactured at standard under absorption costing (Table 25.2) and under direct costing (Table 25.3) may be analyzed as follows:

Cost of goods manufactured at standard:

| | |
|--------------------|-----------------|
| Absorption costing | \$99,540 |
| Direct costing | <u>67,140</u> |
| Difference | <u>\$32,400</u> |

TABLE 25.2 Standard Corporation Cost of Goods Manufactured Statement, Absorption Costing for the Year Ended 20X2

| | | | |
|--|---------------|---------------|-----------------|
| Costs put into production during the period at standard: | | | |
| Direct materials | | \$19,000 | |
| Direct labor | | 44,640 | |
| Factory overhead: | | | |
| Variable | \$6,138 | | |
| Fixed | <u>33,480</u> | <u>39,618</u> | |
| Total costs put into production at standard | | | \$103,258 |
| Plus work-in-process inventory at beginning of the period | | | <u>0</u> |
| Cost of goods in process during the period at standard | | | \$103,258 |
| Less work-in-process inventory at the end of the period at standard ^a | | | <u>3,718</u> |
| Cost of goods manufactured at standard | | | <u>\$99,540</u> |

^a Ending work-in-process inventory:

| | |
|---------------------------|----------------|
| Direct materials | \$1,000 |
| Direct labor | 1,440 |
| Variable factory overhead | 198 |
| Fixed factory overhead | <u>1,080</u> |
| Total | <u>\$3,718</u> |

TABLE 25.3 Standard Corporation Cost of Goods Manufactured Statement, Direct Costing for the Year Ended 20X2

| | | | |
|---|--|--------------|-----------------|
| Variable costs put into production during the period at standard: | | | |
| Direct materials | | \$19,000 | |
| Direct labor | | 44,640 | |
| Variable factory overhead | | <u>6,138</u> | |
| Total variable costs put into production at standard | | | \$69,778 |
| Plus variable work-in-process inventory at beginning of the period | | | <u>0</u> |
| Variable cost of goods in process during the period at standard | | | \$69,778 |
| Less variable work-in-process inventory at the end of the period at standard ^a | | | <u>2,638</u> |
| Variable cost of goods manufactured at standard | | | <u>\$67,140</u> |

^a Ending variable work-in-process inventory:

| | |
|---------------------------|----------------|
| Direct materials | \$1,000 |
| Direct labor | 1,440 |
| Variable factory overhead | <u>198</u> |
| Fixed factory overhead | <u>\$2,638</u> |

The cost of goods manufactured at standard is higher under absorption costing than under direct costing because fixed factory overhead is included as part of production costs. The total fixed factory overhead included in production costs under absorption costing is computed as follows:

| | |
|---|-----------------|
| Total cost of fixed factory overhead at standard included in production costs under absorption costing | \$33,480 |
| Less fixed factory overhead at standard included in ending work-in process inventory under absorption costing | <u>1,080</u> |
| Difference in cost of goods manufactured at standard | <u>\$32,400</u> |

In the above calculation, remember that ending work-in-process inventory is deducted from total production costs to arrive at the cost of goods manufactured. Therefore, any fixed factory overhead included in ending work-in-process inventory will reduce the total cost of goods manufactured.

Income Statement

Absorption costing is associated with the traditional income statement, which emphasizes the amount of gross profit. *Gross profit* is the excess of sales over cost of goods sold. Fixed manufacturing costs are included in the cost of goods sold under absorption costing.

Direct costing is associated with the contribution margin form of the income statement. *Contribution margin* (or marginal income) is the excess of sales over *total* variable costs, including variable manufacturing and variable marketing and administrative expenses. Fixed costs are not included in the cost of goods sold under direct costing. The difference in operating income (or profit before income taxes) under absorption costing and direct costing is due to the amount of fixed factory overhead included in inventories. Where there are no beginning inventories and no ending inventories, the operating income would be the same under both methods. The income statement for the Standard Corporation is shown under absorption costing in Table 25.4, and under direct costing in Table 25.5.

The major differences between the income statements under direct costing and absorption costing are:

- Under direct costing, all the variable expenses (both manufacturing and nonmanufacturing) are deducted first from sales to arrive at contribution margin. Fixed costs are then deducted from contribution margin to arrive at operating income. Under absorption costing all the manufacturing costs (both variable and fixed) are deducted first from sales to arrive at gross profit. Nonmanufacturing costs are then deducted from gross profit to arrive at operating income.

TABLE 25.4 Standard Corporation, Income Statement, Absorption Costing for the Year Ended 20X2

| | |
|---|-----------------|
| Sales | \$165,000 |
| <i>Cost of goods sold:</i> | |
| Opening finished goods inventory | \$0 |
| Plus cost of goods manufactured at standard (Table 25.2) | 99,540 |
| Net total unfavorable variances | <u>9,512</u> |
| Goods available for sale | \$109,052 |
| Less closing finished goods inventory at standard (150 × \$55.30) | <u>8,295</u> |
| Cost of goods sold | 100,757 |
| Gross profit | \$64,243 |
| Less marketing and administrative expenses | <u>45,000</u> |
| Operating income | <u>\$19,243</u> |

- Under direct costing, no production volume variance can occur because fixed factory overhead is not applied to production. Only variable manufacturing overhead is applied to production. Remember that the production volume variance relates only to fixed factory overhead. To determine a product's cost under absorption costing, fixed factory overhead is applied to production. Since fixed factory overhead is not applied to production under direct costing, no production volume variance is possible. Under direct costing, the total budgeted fixed factory overhead is deducted from the contribution margin along with fixed marketing and administrative expenses. All other variances are treated the same under both direct and absorption costing.
- The difference between the operating income for the Standard Corporation under absorption costing and direct costing is due to the amount of fixed factory overhead in the work-in-process and finished goods inventories, computed as follows:

Operating income:

| | |
|---------------------------------|----------------|
| Absorption costing (Table 25.4) | \$19,243 |
| Direct costing (Table 25.5) | <u>15,463</u> |
| Difference | <u>\$3,780</u> |

Ending inventories under:

Absorption costing:

| | | |
|--|--------------|----------|
| Work-in-process inventory (Table 25.2) | \$3,718 | |
| Finished goods inventory (Table 25.4) | <u>8,295</u> | \$12,013 |

Direct costing:

| | | |
|--|--------------|----------------|
| Work-in-process inventory (Table 25.3) | \$2,638 | |
| Finished goods inventory (Table 25.5) | <u>5,595</u> | <u>8,233</u> |
| Difference | | <u>\$3,780</u> |

TABLE 25.5 Standard Corporation, Income Statement, Direct Costing for the Year Ended 20X2

| | | |
|---|---------------|-----------------|
| Sales | | \$165,000 |
| <i>Variable cost of goods sold:</i> | | |
| Opening finished goods inventory | | \$0 |
| Plus variable cost of goods manufactured at standard (Table 25.3) | 67,140 | |
| Net unfavorable variance ^a | <u>6,992</u> | |
| Goods available for sale | | \$74,132 |
| Less closing finished goods inventory at standard (150 × \$37.30 ^b) | <u>5,595</u> | |
| Variable cost of goods sold | | \$68,537 |
| Plus variable marketing and administrative expense ^c | <u>25,000</u> | |
| Total variable costs | | <u>93,537</u> |
| Contribution margin | | \$71,463 |
| Less budgeted fixed factory overhead | \$36,000 | |
| Fixed marketing and administrative expenses | <u>20,000</u> | <u>56,000</u> |
| Operating income | | <u>\$15,463</u> |

^a *Net unfavorable variance:*

| | |
|---------------------------------|----------------|
| Total variance | \$9,512 |
| Less production volume variance | <u>2,520</u> |
| Net unfavorable variance | <u>\$6,992</u> |

^b *Closing finished goods inventory at standard:*

| | |
|--|----------------|
| Total standard unit cost | \$55.30 |
| Less standard fixed factory overhead unit cost | <u>18.00</u> |
| Standard variable unit cost | <u>\$37.30</u> |

^c *Marketing and administrative expenses:*

| | |
|-------------------|-----------------|
| Total amount | \$45,000 |
| Less fixed amount | <u>20,000</u> |
| Variable amount | <u>\$25,000</u> |

See explanation on the next page for the adjustment of the total variance.

The *operating income* under absorption costing was \$3,780 higher than under direct costing. Operating income under absorption costing will be more than under direct costing when inventories *increase* (production exceeds sales) during a period. The reason is *more* fixed costs are inventoried (recorded as an asset) than expensed. Operating income under absorption costing will be *less* than under direct costing when inventories *decrease* (sales exceed production) during a period. Under these circumstances, *less* fixed costs are inventoried than expensed.

Note that the Standard Corporation had no beginning inventories. When beginning inventories exist, they will also impact on the difference between operating income under absorption costing and direct costing. For example, assume the following information for Fax Corporation for 20X0:

| | |
|--|-----------------|
| Standard Cost: | Per Unit |
| Direct materials | \$28.50 |
| Direct labor | 16.20 |
| Factory overhead | |
| Variable | 4.30 |
| Fixed (\$84,000 total) | <u>8.40</u> |
| Total unit cost | <u>\$57.40</u> |
| <i>Production statistics:</i> | |
| Units produced | 10,000 |
| Beginning work-in-process inventory (40% complete for all costs) | 500 |
| Ending work-in-process inventory (20% complete for all costs) | 600 |
| <i>Additional information:</i> | |
| Finished goods inventory: | |
| Beginning | 900 |
| Ending | 1,200 |
| Units sold | 9,700 |
| Selling price per unit | \$120 |
| <i>Selling and general expenses:</i> | |
| Variable | \$20,000 |
| Fixed | \$90,000 |
| Ignore income taxes. | |

The income statement for Fax Corporation is presented in Table 25.6 under absorption costing and in Table 25.7 under direct costing.

TABLE 25.6 Fax Corporation, Income Statement, Absorption Costing for the Year Ended 20X5

| | | |
|---|----------------|-------------------------|
| Sales (9,700 @ \$120) | | \$1,164,000 |
| Cost of goods sold: | | |
| Opening finished goods inventory (900 @ \$57.40) | \$51,660 | |
| Plus cost of goods manufactured (Schedule A) | <u>578,592</u> | |
| Goods available for sale | \$630,252 | |
| Less closing finished goods inventory (1,200 × \$57.40) | <u>68,880</u> | |
| Cost of goods sold | | <u>561,372</u> |
| Gross profit | | \$602,628 |
| Less selling and general expenses (\$20,000 + \$90,000) | | <u>110,000</u> |
| Operating income | | <u><u>\$492,628</u></u> |

Schedule A*Cost of goods manufactured:*

| | | |
|---|--|-------------------------|
| Total costs put into production at standard (10,000 @ \$57.40) | | \$574,000 |
| Plus work-in-process inventory at beginning of the period (500 × 40% × \$ 57.40) | | <u>11,480</u> |
| Cost of goods in process during the period | | \$585,480 |
| Less work-in-process inventory at the end of the period (600 × 20% × \$57.40) | | <u>6,888</u> |
| Cost of goods manufactured | | <u><u>\$578,592</u></u> |

The comparison of operating income for Fax Corporation under absorption costing and direct costing follows:

| | |
|--|-----------------------|
| Absorption costing operating income (Table 25.6) | \$492,628 |
| Direct costing operating income (Table 25.7) | <u>490,780</u> |
| Difference to account for | <u><u>\$1,848</u></u> |

*Analysis of the difference:**Work-in-process inventory:*

| | |
|--|------------|
| Beginning equivalent units (500 × 40%) | 200 |
| Ending equivalent units (600 × 20%) | <u>120</u> |
| Decrease in equivalent work-in-process inventory | (80) |

TABLE 25.7 Fax Corporation, Income Statement, Direct Costing for the Year Ended 20X5

| | | |
|--|------------------|------------------|
| Sales (9,700 @ \$120) | | \$1,164,000 |
| <i>Variable cost of goods sold:</i> | | |
| Opening finished goods inventory (900 @ \$49.00 ^a) | \$44,100 | |
| Plus cost of goods manufactured (Schedule A) | <u>493,920</u> | |
| Goods available for sale | \$538,020 | |
| Less closing finished goods inventory (1,200 × \$49.00 ^a) | <u>58,800</u> | |
| Variable cost of goods sold | \$479,220 | |
| Plus variable selling and general expenses | <u>20,000</u> | <u>499,220</u> |
| Contribution margin | | \$664,780 |
| Less budgeted fixed factory overhead | \$84,000 | |
| Fixed selling and general expenses | <u>90,000</u> | <u>174,000</u> |
| Operating income | | <u>\$490,780</u> |
| Schedule A | | |
| <i>Cost of goods manufactured:</i> | | |
| Total costs put into production at standard (10,000 @ \$49.00*) | \$490,000 | |
| Plus work-in-process inventory at beginning of the period (500 × 40% × \$49.00*) | <u>9,800</u> | |
| Cost of goods in process during the period | \$499,800 | |
| Less work-in-process inventory at the end of the period (600 × 20% × \$49.00*) | <u>5,880</u> | |
| Cost of goods manufactured | <u>\$493,920</u> | |

^a Total unit cost \$57.40 less fixed overhead cost \$8.40.

Finished goods inventory:

| | | | |
|--------------------------------------|---|---------------------------------|----------------|
| Beginning | | 900 | |
| Ending | | <u>1,200</u> | |
| Increase in finished goods inventory | | | <u>300</u> |
| Total change in inventory (increase) | | | <u>220</u> |
| Difference accounted for: | | | |
| Total change in inventory | × | Fixed factory overhead per unit | |
| 220 | × | \$8.40 | <u>\$1,848</u> |

Balance Sheet

The current asset section of the balance sheet will always be less under direct costing than under absorption costing because fixed factory overhead is not included in inventories under direct costing.

Direct Costing and External Financial Statements

Direct costing is not in accordance with generally accepted accounting principles and therefore cannot be used for costing inventories in external financial statements. Neither the Internal Revenue Service (IRS) nor the Securities and Exchange Commission (SEC) accept direct costing. Of course, the opposition of these agencies to the use of direct costing applies only to *external* reports. Firms using direct costing in internal reports for managerial planning, control, and decision making must add back to inventories applicable fixed factory overhead costs to conform with absorption costing procedures for reports issued to stockholders and those filed with the IRS and SEC.

ADVANTAGES OF DIRECT COSTING

Advocacy of direct costing has a long history in accounting and finance. The National Association of Accountants has long favored the use of direct costing and as far back as 1936 issued research reports and other publications pointing out the advantages of direct costing. The rapid expansion of the work of many CPA firms' Management Advisory Services divisions is due in part to the installation of direct costing systems. Much of this work had long been carried out by specialized management consulting firms. It might be pointed out that the advantages or disadvantages do not actually relate to internal use or external use, but rather to the method itself. For many years, companies using absorption costing have made analyses of direct and indirect costs and have prepared break-even charts. However, the necessary data required special studies because the information was not readily available in the accounts as it is in direct costing.

The advantages of direct costing have generally been well recognized by top CFOs, production managers, marketing managers, and cost analysts. Direct costing overcomes the principal problem of absorption costing, that is, the distortion of the time relationship of sales, cost of goods sold, and net income.

Following are the principal advantages of direct costing.

Operations Planning

The plan of operations, or master budget plan, covers all aspects of future operations designed to reach an established profit goal. Direct costing facilitates the compilation of profit-planning data, which cost departments have always developed—often at a great expenditure of time and effort, long before the advent of the present direct costing structures. The readily available data on variable cost and contribution margin permits quick answers to the scores of cost decisions that management must make each day, such as the installation of a new machine or special cost center. Reliable estimates of unitized variable costs and total fixed costs can be readily provided by direct costing. If variable costs are \$14 per unit, which is expected to be 70% of the unit sales price of \$20, in line with similar products, and the total fixed costs are \$45,000, the following quick feasibility computation can be made. The unit sales are projected to be 20,000 per year.

| | Per Unit | Total Amount | Percent |
|----------------------|------------|-----------------|-------------|
| Sales (20,000 units) | \$20 | \$400,000 | 100.0 |
| Variable costs | <u>14</u> | <u>280,000</u> | <u>70.0</u> |
| Contribution margin | <u>\$6</u> | \$120,000 | 30.0 |
| Fixed costs | | <u>45,000</u> | <u>11.2</u> |
| Net operating income | | <u>\$75,000</u> | <u>18.8</u> |

The key to the above computation is the variable cost of \$14. The product would have to sell at \$20, in accordance with the general pricing policy of variable cost being 70% of selling price ($\$14 \div 70\% = \20). The marketing department estimates that annual sales would be approximately 20,000 units. With \$400,000 sales, the net operating income would be \$75,000, or 18.8% of sales. The project would be worth exploring further, since the net operating income percentage comfortably exceeds the break-even point, described under cost-volume-profit analysis.

Break-Even or Cost-Volume-Profit Analysis

A great many applications involving break-even analysis or cost-volume analysis are continually used by management in the day-to-day operations of a manufacturing company. Most managerial decisions are cost-related, and an understanding of these relationships is essential.

There are simple computations to determine the break-even point after the contribution margin and fixed costs are known. The *break-even point* is the sales volume at which there will be neither a profit nor a loss. Below

this level a loss will occur; above this level a profit will be earned. The break-even point is where the *total contribution margin is equal to the total fixed expenses*. In the above example, the contribution margin was 30% of sales, or \$6 per unit. Therefore, \$45,000 of fixed costs divided by 30% gives \$150,000 of break-even sales.

To arrive at the number of units that have to be sold to break even, either the fixed cost could be divided by the contribution margin per unit or the total break-even sales could be divided by the unit selling price. The number of units that must be sold to break even is

$$\frac{\$45,000 \text{ fixed cost}}{\$6 \text{ unit contribution margin}} = 7,500 \text{ units}$$

or

$$\frac{\$150,000 \text{ total break-even sales}}{\$20 \text{ unit selling price}} = 7,500 \text{ units}$$

From the break-even sales computed above, the following summary can now be prepared:

| | Per Unit | Total Amount | Percent |
|------------------------------|------------|-----------------|-----------|
| Sales (7,500 units) | \$20 | \$150,000 | 100 |
| Variable costs (7,500 units) | <u>14</u> | <u>105,000</u> | <u>70</u> |
| Contribution margin | <u>\$6</u> | <u>\$45,000</u> | <u>30</u> |

It can be seen that the break-even sales point would be at \$150,000 or 7,500 units. At the break-even point the contribution margin (\$45,000) and the fixed costs (\$45,000) are equal.

Management Decisions

An adequate direct cost system will, of necessity, have to provide for the proper segregation of fixed and variable costs. Mixed costs will have been separated into fixed and variable components, and thus a convenient system is provided for accumulation and evaluation of costs. Forecasting of costs and contribution margins, flexible budget analysis, relationship of costs to sales volume and sales price, and many other cost relationships can be readily studied. The direct cost income statement will enable management to see and understand the effect that period costs have on profits and will facilitate better decision making.

Product Pricing

Marketing department managers have been using variable costing in setting selling prices for many years. The understanding of contribution margin and sales pricing is one of the first things they must learn if they are to be successful. Retailers know they must add a given percentage to cost to arrive at selling price. The contribution margin (sales minus variable costs) must be large enough to cover all fixed expenses such as salaries, rent, and taxes and also provide a reasonable income and an adequate return on investment.

Of course, retailers cannot arrive at unrealistic selling prices because their competitors may have lower selling prices. The law of supply and demand will come into operation. If the price is too high, customers will not buy and the inventory will not move. Therefore, retailers will have to lower the selling price by reducing their rate of markup; and if the final return is to be maintained, they will have to reduce variable and/or fixed costs—a difficult task, at best.

Management Control

The reports based on direct costing are far more effective for management control than those based on absorption costing. First, the reports are more directly related to the profit objective or budget for the period. Deviations from standards are more readily apparent and can be corrected more quickly. The variable cost of sales changes in direct proportion with volume. The distorting effect of production on profit is avoided, especially in a period following high production when substantial amounts of fixed costs are carried in inventory over to the next period. A marked increase in sales in the period after high production under absorption costing will have a significant negative impact on the net operating profit as inventories are liquidated.

Direct costing can help to pinpoint responsibility according to organizational lines; individual performance can be evaluated on reliable and appropriate data on the basis of current period activity. Operating reports can be prepared for all segments of the company, with costs separated into fixed and variable and the nature of any variance clearly shown. The responsibility for costs and variances can then be more readily attributed to specific individuals and functions, from top management on down.

DISADVANTAGES OF DIRECT COSTING

The principal disadvantage of direct costing is its lack of acceptance for external reporting by the American Institute of Certified Public Accountants

(predecessor of the Financial Accounting Standards Board), the Internal Revenue Service, and the Securities and Exchange Commission. Their opposition is highlighted as follows:

- *American Institute of Certified Public Accountants.* According to AICPA Accounting Research Bulletin No. 43, “The primary basis of accounting for inventories is cost, which has been defined generally as the price paid or consideration given to acquire an asset. As applied to inventories, cost means in principle the sum of the applicable expenditures and charges directly or indirectly incurred in bringing an article to its existing condition and location.” This section also states that “It should also be recognized that the exclusion of all overheads from inventory does not constitute an accepted accounting procedure.” The Financial Accounting Standards Board in its Interpretation No. 1 has supported the AICPA position.
- *Internal Revenue Service.* Under IRS Regulations, certain costs must be included or excluded from inventory for income tax reporting *depending on* their treatment for financial reporting, “but only if such treatment is not inconsistent with generally accepted accounting principles.” Therefore, firms using direct costing must adjust inventories and net income to what they would have been under absorption costing for income tax purposes.
- *Securities and Exchange Commission.* The SEC also does not accept financial reports prepared under the direct costing method. Primarily this lack of acceptance is because direct costing is not a generally accepted accounting procedure. It is also an SEC policy to encourage consistency in financial reporting. The reports of firms using direct costing must also be adjusted for inventories and net income to what they would have been if absorption costing had been used.

The opponents of direct costing argue that while direct costing appears theoretically attractive, it cannot be reliably achieved in practice. For example, there are a number of mixed costs that cannot be readily separated into variable and nonvariable costs. However, this argument against direct costing is on weak grounds. There are statistical techniques and other methodologies that can be employed that allow management to obtain a reasonable estimate of the variable and nonvariable components. Breakdown of the components using these methodologies is at least as good as, if not more reliable than, the large number of arbitrary distributions of many indirect costs made in absorption costing that are only slightly related to manufacturing.

ADJUSTING FINANCIAL STATEMENTS FOR EXTERNAL REPORTS

Companies using direct costing may obtain all the benefits of that method for planning, control, and managerial decision making and, at the end of the period, make a simple journal entry to adjust the data for external reporting. A reconciliation of direct costing to absorption costing will be required as long as direct costing is not accepted by the AICPA, IRS, or SEC.

The only items that need to be adjusted are inventories, cost of goods manufactured, and cost of goods sold for the amount of fixed factory overhead that was excluded from product costs under the direct costing method.

BOTTOM LINE

- Direct costing has now come of age and is proving to accountants to be an extremely valuable tool in planning and controlling operations in many large industrial companies. Though still not as widely employed as absorption costing, it is steadily gaining in use.
- Direct costing product costs include only those manufacturing costs that are closely related to the product and vary with production volume.
- Under absorption costing all manufacturing costs, direct and indirect, are included as product costs.
- The proponents of direct costing maintain that fixed or nonvariable costs, whether in factory overhead or selling or administrative costs, are period costs related to time, have no future benefit, and are thus not acceptable inventory costs.
- At present there is disagreement among accountants on the use of direct costing in external reports because of the exclusion of fixed factory overhead costs from inventories and its effect on net income. However, there is little doubt among accountants that direct costing is better suited for internal management purposes in planning, control, and decision making.
- A large number of companies now keep their records for both internal and external reporting needs.
- The records are maintained on the direct costing basis for management's daily needs, and at the end of the year, when tax returns and formal financial statements are prepared for regulatory agencies and stockholders, a simple adjustment is made.
- The fixed factory overhead costs that were excluded under direct costing are added back to inventories and cost of goods manufactured, and the net income is adjusted to what it would have been if absorption costing had been used.

- Under absorption costing net income will tend to vary with production because the deferred fixed costs are included in inventory, whereas under direct costing net income will vary with sales.

- f indicates entries in figures
- t indicates entries in tables
- n indicates entries in footnotes

- ABC. *See* Activity-based costing
- Abnormal defective units, 699
- Absorption costing, 791
 - conclusion, 807–808
 - contrast. *See* Direct costing
 - example, 800t
- Absorption costs, usage, 682
- Acceleration option, 79, 83
- Accounting deficiency, 350n
- Accounting information pool, 627f
- Accounting Principles Board (APB), Opinion No. 19, 311n
- Accounts
 - administration/collection, cost, 594
 - analysis, 172–176. *See also* Analysis of accounts method
 - monthly changes, company analysis, 173t
- Accounts receivable, 90–91
 - changes, 174
 - collections, 167, 284
 - creation, 591–592
 - management, 282–283
 - practice, 600–601
 - monitoring, 598–599
 - aging schedules, usage, 599
 - turnover ratio, 282–283
- Accruals, usage, 658
- Accumulated depreciation, 442
- ACE. *See* Allowance for corporate equity
- Acid-test ratio. *See* Quick ratio
- Activities
 - cost drivers, 661t
 - types, 661t
- Activity-based costing
 - application, steps, 661–662
- Activity-based costing (ABC), 11t
 - contrast. *See* Cost allocation; Traditional costing
 - example, 662–664
 - methods, usage, 663–664
 - system, implementation, 661–662
 - usage, 660–664
- Activity ratios, 282–284
- Actual costing, 750
 - normal costing, contrast. *See* Factory overhead
- Actual cost of work performed to date (ACWP), 675
- Actual factory overhead
 - accounting, 660
 - costs, 658
 - accounting, 658–659
 - example, 781t
- Actual Gross Profit Statement, 400t
- Actual performance, 394
- ACWP. *See* Actual cost of work performed to date
- Adelphia Communications
 - audit committee, 4n
 - scandals, 227
- Adjustable-rate preferred stock (ARPS), 116–117
- Adjusted discount rate
 - equation, 565
 - technique, 561n
 - usage, 561
- Adjusted present value (APV), 510–514
 - comparison. *See* Net present value
 - equation, 510, 511
 - NPV, difference, 512, 514t
- Administration expenses. *See* Total administration expenses
- Administrative budgets, 732–736
- Administrative costs, 624
- Administrative expenses budgets, 735
 - example, 736t
- Advance Pricing Agreement (APA) Program design, 423
 - existence, 424
- Advertising expenditures, impact, 280

- After-tax claim, 508
 After-tax interest rate, 569
 Agency explanation, 108, 111
 Agency problems, 31
 Agency relationship, 43–47, 53
 capital structure, relationship, 46–47
 costs, 45–46, 53
 problems, 44–45
 Agency theory, 111
 AICPA. See American Institute of Certified Public Accountants
 AIG. See American International Group
 Albright, Tom, 190n
 All-equity-financed project, value (calculation), 511
 All-in-cost of debt, 63–64
 Allowance for corporate equity (ACE), 221n
 Alternative risk transfer (ART), 237, 252–255
 Amazon.com, fiscal year results, 313
 American Institute of Certified Public Accountants (AICPA), Accounting Research Bulletin No. 43, 806
 American International Group (AIG), 254
 American option, 245
 usage, 519
 Amortization, 66
 schedule, 66, 77
 Amortizing loan, 65. See also Fully amortizing loan
 Amortizing structure, 64
 Analogical cost estimation techniques, 631–632
 Analysis of accounts method, 172
 Analysts, conflict of interest, 3t
 Analytical cost estimation techniques, 632–633
 Ang, James, 110n
 Annuity, amount (determination), 65
 Antitakeover devices, 45
 APA. See Advance Pricing Agreement
 APB. See Accounting Principles Board
 Applied factory overhead
 accounting, 660
 costs, 657–658
 Appraisal, system, 340
 APV. See Adjusted present value
 Arm's-length price, 421
 Arm's-length transactions, 414
 Armstrong, Don, 558n
 ARPS. See Adjustable-rate preferred stock
 Arrearage, 117
 Arrears, 117
 ART. See Alternative risk transfer
 Assembly department
 actual controllable costs, company schedule, 358t
 controllable costs
 ex ante flexible budgets, 357t
 ex post budget, 359t
 end-of-the-period controllable costs, 358
 supervisor, level 1, 343
 Asset-backed securities, 93
 rating, rating agency criteria, 134–136
 usage, 126
 Assets
 acquisition, 438–439
 beta, 507, 510
 equation, 511
 book value, 442
 classes, exposure (obtaining), 142
 disposition, 439–443
 expected cash flows, 455–457
 gross amount, 545
 management, 283–284
 reduction, 29
 residual value, 562
 sale, 455–457
 gain/loss amount, calculation, 132
 salvage value, 211
 swaps, 250
 types, 52
 value, volatility, 519
 Asset securitization, 90–91, 123, 124–139
 accounting methods, 130t
 conclusion, 149–150
 transaction, illustration, 125–127
 Asset servicing, accounting methods, 130t
 Atkinson, Anthony A., 348n, 349n, 492n
 Attainable standards, 753
 Auction preferred stock, 117
 Auditor independence, 3t
 Authority, delegation, 340
 Autonomy, 419
 impact, 408
 Autonomy dimension, expense. See Organizational decentralization
 Available-for-sale security, 130t
 Average credit sales per day, 274
 Average day's cost of goods sold, 273
 Average day's purchases on credit, 275
 Average tax rate, 206
 graph, 207f
 ratio, 206

- Avoidable costs, 417n
- Backdated option, 11n
- Backdating scandals, 10n–11n
- Back expenses, addition, 287
- Backflush costing, 694–695
- Bad debt
 - consideration, 594
 - expense, impact, 280
 - probability, 596
 - risk, 594
- Balabani, Stavroula, 30n
- Balanced scorecard, 11t
 - approach, requirements, 191
 - measures, 187–188
 - process, 187
 - flowchart, 188f
 - scorecard, 190–191
 - usage, 186–191
 - reason, 188–190
- Balance sheet, 802
 - analysis, 289–290
 - example, 264t
- Bankers' acceptances, 90
- Bank financing, 87–88
- Banking. See Concentration banking
- Bank loan-marketable securities decision, 171
- Bank loans, 70. See also Senior bank loans
- Bankruptcy, 39–40
 - clues, 326
 - costs, 39–40
 - indirect cost, 40
 - legal status, 37
- Bankruptcy Code, 39
- Bankruptcy remote entities, 129
- Banks, Erik, 252n
- Banks, selection, 585
- Barr, Stephen, 606n
- Bartholomew, Doug, 607n
- Basic earning power
 - equation, 265, 268
 - ratio, 264
- Basic standard, 752
- Baskets, 80
 - default swaps, 250
 - proportion, 81
- Baumol, William J., 584n
- Bautista, Alberto J., 561n
- BCWP. See Budgeted cost of work performed to date
- Beitz, W., 631n
- Benaroch, Michel, 493n
- Benchmarks, selection. See Chief Financial Officer; Pfizer, Inc.
- Bermuda
 - option, 245
 - tax haven, 219
- Best efforts arrangement, 73
- Beta
 - assumption, 508
 - measurement, 507
 - translation. See Equity
- Bird in the Hand theory, 107, 108–109
- Black, Fischer, 112n, 519n
- Black-Scholes option pricing model, consistency, 522n
- Board of directors, fiduciary duty, 45
- Bondholders, bonds (sale), 80
- Bond issues
 - defeasance, 79
 - design, 82–83
 - features/provisions, 73–80
 - refunding, 78
- Bonds, 71–86. See also Eurobonds
 - contracts, 71
 - denomination, 74
 - interest, 74–75
 - issuance, 71–73
 - obligations, 74
 - par amount, cash payment, 79
 - retirement, 79
 - security, 75–77
 - seniority, 77
 - structure, 148f
 - term to maturity, 74
 - types. See Secured bonds
- Book earnings, leasing (impact), 540–541
- Book value, market value (contrast), 286–287
- Booth, Lawrence, 30n
- Booz Allen Hamilton report, 191–192
- Borrower clean-up, 88
- Borrowing
 - dependence, 323
 - maturity, length, 86
- Borrow-to-buy decision, 560–574
 - representation, 567t
- Bought deal, 73
- Break-even analysis, 803–804
- Break-even measure, 481
- Brealey, Richard, 565
- Broker, involvement. See Leveraged lease
- Bruns, W.J., 662
- Budgetary planning, 752

- Budget (controllable) variance, 781–782
- Budget development, 159
- Budgeted average gross profit, 402
- Budgeted balance sheet, 744
 - example, 747t
- Budgeted cash flow statement, 745t–746t
- Budgeted cost of work performed to date (BCWP), 675
- Budgeted costs, 626–627
- Budgeted financial statements, 723
- Budgeted Gross Profit Statement, 399t
- Budgeted income statement, 740
 - example, 742t
- Budgeted schedules, 723–740
- Budgeted statement of cash flows, 740–744
- Budgeted summaries, 740–744
- Budgeting, 154, 165–172
 - procedural aspects, 720
 - process, 159f, 160–161
 - relationship. See Financial planning; Strategy
- Budget manual, preparation, 720
- Budgets, usage, 758
- Budget system. See Zero-based budget system
 - relationship. See Program planning
- Building, tax basis, 459f
- Bullet payment, 66
- Bullet structure, 64
- Business entities, 54
- Business interruption, 238
- Business-process metrics, 189
- Business risk, 24, 431
 - increase, 48, 50
- Buying responsibility center manager, 406
- By-products, 711–714
 - accounting, 712–714
 - costing, 703
 - conclusion, 716–717
 - production, recognition, 713
 - sale, recognition, 712–713
- Call, exercising, 119
- Callability. See Preferred stock
- Callable bonds, 140n
 - issuance, 83
- Callable preferred stock, 119
- Call option, 244, 519, 521
- Canada, adjusted income penalty, 422
- Cancelable operating lease, 539
- Cap
 - advantage, 65
 - agreements, 248–250
- Capacity, consideration, 597
- Capital
 - gains, 214–216, 440
 - calculation, 215
 - investment, calculation, 186
 - leases, accounting, 545–546
 - loss, 440
 - market value, calculation, 186
 - meaning, 430n
 - proportions, 21f
 - rationing
 - impact, 484
 - relationship. See Internal rate of return
 - recovery period, 480–481
 - spending, financing (sources), 322–323
 - structure, 430n
 - change, 514t
- Capital, cost, 41–43, 58, 61f, 431, 466. See also Projects
 - adjustment. See Company
 - calculation, 185
 - equation, 499, 522
 - estimate, sensitivity, 517t
- Capital asset pricing model (CAPM), 510n
 - basis. See Projects
- Capital budgeting, 429, 432–437, 463
 - conclusion, 454, 495–496
 - decision, risk (incorporation), 514–518
 - evaluation techniques, 464–466
 - operation, 465
 - issues, 483–486
 - problem, 562
 - process, 433f
 - risk, relationship, 497
 - conclusion, 528–529
 - scale differences, 483–484
 - technology, justification, 491–494
 - unequal lives, 484–486
- Capital budgeting techniques, 160
 - advantages/disadvantages, 487t–488t
 - comparison, 486–489
 - coverage, 481n
 - practice, 489–490
- Capital expenditures coverage ratio, 324–325
- Capitalization avoidance, 538–539
- Capitalization rate, 54
- Capital structure
 - analysis, 47–48
 - decisions, 17, 52
 - determination, 53
 - example, 26–28
 - financial distress, relationship, 37–47
 - financial leverage, relationship, 25–29

- Capital structure (*Cont.*)
 industry classification, 47–49
 irrelevance, 57f, 60f
 interest, tax deductibility, 61f
 observations, 49–50
 optimum, 47–51
 pecking order explanations, 51–52
 prescription, 51–52
 ratios, 49f
 relationship. See Agency relationship;
 Financial distress; Interest deductibility
 taxes, relationship, 31–37
 theory, 53–62
 financial distress costs, relationship, 59–62
 trade-off analysis, 51–52
- CAPM. See Capital asset pricing model
- Captive leasing, 541
- Captives, 253–254
- Carryback, IRC permission, 35n
- Carrying costs, 594
- CAS. See Casualty Actuarial Society
- Cash
 acceleration methods. See Incoming cash
 concept, usage, 311
 disbursements
 basis, 737
 example, 739t
 forecasting, 581–582
 holding, amount, 589
 investment, 273
 determination, 583–584
 needs, monitoring, 581–582
 outlay, 561–562
 payment, deceleration, 586
 receipts, example, 738t
 receiving process, 585
- Cash, costs, 583
- Cash account, changes, 174
- Cash balance
 compensating balance, 88
 holding, reasons, 582–583
- Cash before delivery (CBD), credit terms, 592n
- Cash budget, 166–172
 example, 741t
 monthly budget, 169t–170t
 usage, 736–740
 usefulness, 160
- Cash conversion cycle (CCC), 276
- Cash dividends, taxability, 112
- Cash flow analysis, 309, 429
 conclusion, 327–328, 454
 simplifications, 453–454
- Cash flow (CF). See Expected cash flows;
 Free cash flow; Operating cash flows
 assumption, 481n
 budgeted statement. See Budgeted state-
 ment of cash flows
 calculation, 461
 classification, 312
 computation, worksheet (usage). See New
 cash flow
 discount rate, 55
 entry/exit, 166–167
 estimation, 465t, 504
 hedge, 240
 inclusion, 314
 information, usage, 325–327
 leasing, impact, 540–541
 measure, 325
 measurement, difficulties, 309–311
 necessity, 431–432
 overview, 743t
 projection, potential (underestimation), 492
 ratios, 324–325
 relevance, 57
 risk, 431, 525
 stress, payment structure (relationship),
 136
 timing, 475
 uncertainty. See Future cash flows
 relationship. See Simulation
 usefulness. See Financial analysis
- Cash flow interest coverage ratio, 288
- Cash flow return on investment (CFROI), 184
- Cash flow statement, 266t, 311–316
 direct method, 311–312
 indirect method, 311–312
 reformatting, 314t
 relation, examination, 313
- Cash flow to capital expenditures ratio,
 324–325
- Cash flow to debt ratio, 325
 usage, 326f
- Cash inflows (CIFs), 164, 471
 change, 448
 estimation, 599
 reinvestment, 475
 sales, relationship, 183
- Cash management, 581–589
 techniques, 584–588
- Cash on delivery (COD), credit terms, 592n
- Cash outflows (COFs), 164, 165, 471. See
 also Wages
- Cash value added (CVA), 184

- Casualty Actuarial Society (CAS), 231–232
- Catastrophe-linked bonds, 253
- Catastrophic control, 233–234
- Catastrophic risk management, 234
- Cavaliere, Sergio, 632n
- Cayman Islands, tax haven, 219
- CBD. See Cash before delivery
- CCC. See Cash conversion cycle
- Certainty equivalents, 525–526
 - NPV, 526
 - value, determination (reliability problems), 526
- Certificates of indebtedness, 71
- CF. See Cash flow
- CFO Research Services report, 191n
- CFROI. See Cash flow return on investment
- Chance, Don M., 520n
- Change-in-control, occurrence, 80n
- Chapter 7 bankruptcy, 39
- Chapter 11 bankruptcy, 39
- Character, consideration, 597
- Chattel mortgage, 92
- Check processing, usage, 586
- Chemical hazards, 230
- Chief Financial Officer (CFO)
 - banker, recommendation, 147
 - benchmark, selection, 305
 - capital, raising, 111
 - capital budgeting decisions, 497
 - cash flow uncertainty, assessment, 171
 - cash management, 584–585
 - communications, 8
 - compliance obligations, 6–8
 - concern, 51
 - credit policy, liberalization, 595
 - economic models, usage, 78
 - fiduciary duty, 12–14
 - firm bid, 73
 - fixed-rate bond, synthetic creation, 85
 - funds, raising, 82
 - holding cost, transactional cost (comparison), 583
 - legal compliance, 6–8
 - performance evaluation, 10–12
 - regulatory compliance, 6–8
 - relationship. See Sarbanes-Oxley Act of 2002
 - responsibilities, 329
 - expansion, 6–14
 - flowchart, 7f
 - update, 14
 - risk management, 12
 - role, 191–192. See also Risk management
 - change, 1
 - shares, reduction, 114
 - SOX provisions, impact, 4–6
 - staff, bank staff (coordination), 588–589
 - strategic planning, 10
 - surveys, 10n
 - target capital structure, example, 42–43
 - tax compliance, 6–8
 - warnings, 162
- Chief Financial Officers Act of 1990 (PL 101-576), 2n
- Choudhry, Moorad, 123n, 250n
- CIFs. See Cash inflows
- Circulating capital, 579
- Cisco Systems, Inc., synthetic lease, 559n
- C.I.T. Financial Corporation, 89
- Citizenship, impact, 388
- Classified stock, 102–103
- Clearinghouse, impact, 242
- Cleary, Sean, 30n
- CLNs. See Credit-link notes
- Closely held corporation (close corporation), 100
- CMR. See Contribution margin ratio
- COD. See Cash on delivery
- Coefficient of variation, 502–504
 - equation, 504
 - relationship. See Project risk
- COFs. See Cash outflows
- Coleco Industries, problems, 161–162
- Collar, 117
- Collateral
 - backing, 90
 - consideration, 597
 - credit quality, 135
 - inventory, control, 92–93
 - pool, 137
 - usage, 86
- Collateral trust bond, 77
- Collection policies, 597–598
- Commercial insurance policies, 236
- Commercial motor/fleet insurance, 238
- Commercial paper, 89
 - short-term security, 89
- Commitment fee, 88
- Committed fixed costs, discretionary fixed costs (relationship), 628
- Committed fixed expenses, 369
- Committee of Sponsoring Organizations of the Treadway Commission (COSO), 231–232
 - terms, distinctions, 234–235

- Committee on Accounting Procedures, 751
- Commodity swaps, 248
- Common costs. *See* Incremental common costs
 - cause-and-effect relationship, 371
 - estimation, 371
- Common fixed expenses, 369
- Common-size analysis, 289–290
- Common-size balance sheet, 290
 - illustration, 291f
- Common-size income statement, 290
 - illustration, 291f
- Common stock, 100–115
 - performance, 148–149
- Communication, cost, 101
- Company
 - capital cost, adjustment, 516–518
 - classification, 315
 - debt financing, 508
 - equity financing, 508
 - financial flexibility, 325
 - financing, 18f
 - behavior, 50–51
 - lever-up, 317
 - marginal tax rate, 508
 - organization
 - functional approach, 330
 - geographical approach, 330–331
 - product approach, 330
 - performance, comparison, 354–356
 - taxable income, 445–446
 - tax-related cash outflow (reduction), depreciation (impact), 446
 - tax risk, 421–422
 - value
 - calculation, 431
 - increase, 48
- Comparable uncontrolled method, 421
- Comparative advantages, 156
- Compensating balance, 88
 - form, 583
- Competitive advantages, 156
- Competitive bidding underwriting, 73
- Competitive rivalry, 194
- Competitors, credit terms, 597
- Complementary projects, 436–437
- Compliance risk, 201, 203–204
- Component percentage, 263
 - ratios, 285–287
- Compound option, 519
- Computer depreciation costs, allocation (example), 620
- Computer Security Institute (CSI) report, 494n
- Concentration banking, 586
- Concentration risk, 135
- Conditional sale leases, 533, 557
- Conditions, consideration, 597
- Confidentiality, 101
- Constant-flow manufacturing, 680–682
- Constant stage, 756
- Consumer Products Division, performance evaluation report, 376t, 380t, 388t
- Contingent insurance, 255
- Contingent projects, 436
- Contingent voting rights, 119
- Contract of indemnity. *See* Indemnity
- Contractors, rights, 238
- Contribution income statement, 369
- Contribution margin, 22
 - usage, 796
- Contribution margin income statement, 369
- Contribution margin ratio (CMR), 373
- Control
 - essentials, 339–340
 - technique, 339
- Controllability
 - impact, 360–361
 - principle, 339
- Controllable assets
 - amount, calculation, 391
 - equation, 391
 - inclusion, 375
 - valuation/allocation, 388–390
- Controllable costs, 344t, 345–346
 - inclusion, requirement, 365
 - insufficiency, 364–365
 - knowledge, 375
 - noncontrollable costs, relationship, 627
- Controllable fixed expenses, nomenclature, 369
- Controllable income
 - amount
 - decline, 378
 - forecast, 393
 - budgeting, 355
 - estimation, 376n
 - nomenclature, 369
 - statement
 - example, 369t
 - usage, 367
- Controllable revenues, 365
 - equation, 392
 - knowledge, 374

- Controllable variance. See Budget variance
- Controlled disbursements
 impact, 586
 usage, 588–589
- Controlling, costs (relationship), 626–629
- Controlling financial interest, 94
- Conventional factoring, 91
- Conventional income statement, example, 366t
- Conventional master budget system, 721–723
- Conventional notes, S&P linked notes (contrast), 148f
- Conversion costs, 615
 application rate, predetermination, 674
 relationship. See Prime costs
- Conversion options, 82–83
- Convertibility. See Preferred stock
- Convertible bonds, 81, 140
- Convertible preferred stock, 118
- Convertible securities, 81–82
- Copeland, Tom, 184n
- COQ. See Cost of quality
- Corporate bonds, contrast. See Medium-term note
- Corporate fraud accountability, 4t
- Corporate income tax rates, 219
 ranking, 220t–221t
- Corporate insurance policies, 238
- Corporate responsibility, 3t
- Corporate risk management, 227
 conclusion, 255–257
- Corporate taxable income, 207–216
 equation, 209t
- Corporate tax director, heading, 198
- Corporate taxes
 basics, 197
 conclusion, 224–225
 rates, 219
- Corporation
 capital cost, determination, 41–42
 differences, 101
 federal income tax rate schedule, 206t
 income statement, 265t
 perils, types, 229–230
 quarterly revenues, 163–164
 risk, shift, 93–94
 stock repurchase, 113
 taxation, 205–218
 payment, 420–421
- COSO. See Committee of Sponsoring Organizations of the Treadway Commission
- Cost allocation, 345, 371–372
 system, ABC system (contrast), 662
- Cost and schedule performance reporting (CSPR), 675
- Cost center, 340
 decision making, 360–364
 restriction, 361
 manager, performance, 374
 performance evaluation, 356–364
 report, 359, 360t
 variables, impact, 356
- Cost contribution arrangements, 423, 424
- Cost estimation
 basics, 630
 intuitive/analogical techniques, 631
 techniques, 630–633. See also Analogical cost estimation techniques; Analytical cost estimation techniques; New product cost estimation; Parametric cost estimation techniques
- Cost of capital. See Capital
- Cost of goods manufactured statement, 793–796
 data, 793t–794t
 example, 795t
- Cost of goods sold. See Average day's cost of goods sold
 budget, 732
 example, 733t–734t
 inclusion, 366
 usage, 279
- Cost of quality (COQ), 763–764
- Cost of sales ratio (CSR), 396
- Cost plus method, 421
- Cost-plus transfer price, 412–413
- Cost pool, 646
- Costs
 accounting, 688–689, 691–692
 JIT philosophy, relationship, 764–769
 classification, 331–332, 611
 conclusion, 633
 product basis, 614
 control, 334
 determination, 346–347
 objective, 751
 data, example, 714t
 direct control, 343
 flow, 673f
 function, analysis, 625t
 functional area classification, 624–625
 incurrence, authority/responsibility (delegation), 340

- Costs (*Cont.*)
relationship. See Controlling; Decision making; Planning; Volume tracing ability, 622–623
- Cost sharing arrangement, 424
- Cost variance, 396
analysis, 401t
- Cost-volume-profit analysis, 803–804
- Coupon, 74
interest rate, 139–140
rate, 74
equation, 145
reset formula, 145
- Covenants, 71
- Coverage ratio, 262. See also Cash flow interest coverage ratio; Fixed charge coverage ratio; Interest coverage ratio
indication, 288–289
usage, 287–289
- Credit
backup line, 86
capacity, preservation (capitalization avoidance), 538–539
collection policies, relationship, 596–598
costs, 592–595
customization factors, 144
days, number (equation), 165, 275
derivatives, 250–252
enhancement, 128, 136–139. See also External credit enhancement; Internal credit enhancement
cost, 139
event, occurrence, 250
extension, reasons, 592
policies, establishment/change, 599–600
risk, 229
sales, equation. See Daily credit sales
sales per day. See Average credit sales per day
terms, equitability, 597
- Credit default index swaps, 250
- Credit default swaps, 250–251
- Credit-link notes (CLNs), 250, 251–252
- Creditors
incentives, 39n
market risk, 507–508
- Credit Research Foundation, 596n
- Creditworthiness, perception, 138
- Criminal fraud accountability, 4t
- Critical level, determination, 362
- Cross-currency swaps, 247
- Cross-over discount rate, 470
solution, 470–471
- CSI. See Computer Security Institute
- CSPR. See Cost and schedule performance reporting
- CSR. See Cost of sales ratio
- Culp, Christopher L., 229, 230n
- Cumulative dividends, noncumulative dividends (contrast), 117
- Currency swaps, 247–248
- Current assets
investment amount, 580
physical location, problem, 390
- Current capital, 579
- Customers
bargaining power, 194
cash flow patterns, 597
credit terms, compliance (estimation), 599
creditworthiness, factors, 597
payment, likelihood, 596
relations, 388
- CVA. See Cash value added
- Dai, Jian S., 630n
- Daily credit sales, equation, 274
- Dattatreya, Ravi, 140n, 141n, 143n
- Davis, Henry A., 123n, 250n
- Davis, Stan, 190n
- Day, George S., 158n
- Days payables outstanding (DPO), 275–276
equation, 581
- Days sales in inventory (DSI)
equation, 274, 275, 580, 581
operating cycle, relationship, 580
- Days sales outstanding (DSO), 274–275
calculation, 598
equation, 580, 581
operating cycle, relationship, 580
- Dealer credit, 591–592
- Dean, Steve R., 540n
- Debt
book value, 48n
equity, contrast, 18–21
expense, impact. See Bad debt expense
financing, types, 63
interest, payment, 75
tax deductibility, 58–59
obligations, 29
features, 64–65
proportion, 510
ratio, 19
decrease, 49
increase, 50
retirement, 77–80

- Debt (*Cont.*)
 - riskiness, 42
 - types, 63–64
 - usage, 32, 55
 - value, 59n
- Debt-equity continuum, 80
- Debt-equity ratio, 20, 510–511
- Debt financing
 - benefits/costs, 47
 - conclusions, 95–97
 - governance value, 31
 - increase, 33
- Debt principle repayment, payment, 288
- Debt-to-assets ratio, 19
 - reduction, 20
- Debt-to-capital ratio, 20
- Debt-to-equity ratio, 285, 545–546
- Decentralization
 - action, 338
 - advantages, 337–338
 - cost, 338
 - problems, 337–338
- Decentralized operations, 329
 - conclusion, 350–352
- Decision making, costs (relationship), 626–629
- Default risk, level, 135
- Defeasance, 79. See also Bond issues
- Defective units, 697. See also Abnormal defective units; Normal defective units
 - accounting, 699
- Deferred income taxes, change, 320–322
- Deferred interest bonds, 75
- Deferred tax asset, 208
- Deferred tax liabilities, 212n
- Degree of operating leverage (DOL), 25
- Degree of total leverage (DTL), 25
- Delivery date, 241
- Denominator variance, 782–784
- Departmental work-in-process inventory
 - accounts, 682
- Departments
 - costs, 623–624
 - distribution rate, 672
 - level 1, 342
 - production, 678–680
- Depreciation. See Accumulated depreciation
 - change, calculation, 446
 - comparison, 446
 - expenses, 212
 - impact. See Tax-related cash outflow method, 211
 - rate, 211. See also Modified Accelerated Cost Recovery System
 - recapture, 215, 440
 - tax purposes, 211–214
- Derivatives, 237, 239–252
 - instruments
 - designation, 240
 - treatment, 239–240
- Differential cost, 417n
 - usage, 626
- Dill, David A., 561n
- Direct cash flow, leasing
 - computation, worksheet (usage), 563
 - evaluation, 565
 - impact, 561–563
 - valuation, 563–566
 - worksheet, 564t
- Direct costing, 791
 - absorption costing, contrast, 792–802
 - advantages, 802–805
 - conclusion, 807–808
 - disadvantages, 805–806
 - example, 795t, 801t
 - external financial statements, relationship, 802
 - management decisions, 804
 - meaning, 791–792
 - SEC acceptance, 802
- Direct costs, 622–623
- Direct labor
 - budget, 728–729
 - example, 730t
 - cost, 346
 - assumption, 687
 - charge, 673–674
 - estimation, 655
 - efficiency standards, 755–758
 - efficiency variance, 777–778
 - hours, estimation, 655–656
 - price (rate) variance, 776–777
 - calculation, 776
 - price standards, 755
 - procedures, 682–683
 - standards, 755–758
 - variances, 775–778
- Direct leases, 546
- Directly traceable fixed expenses, 369
- Direct materials, 636. See also Pure direct materials
 - addition, 692–693
 - cost, estimation, 654–655
 - efficiency (quantity) standards, 773–774

- Direct materials (*Cont.*)
 - efficiency (usage) standards, 754–755
 - efficiency (usage) variance, 773–774
 - price (rate) standards, 753–754
 - price variances, 771–773
 - efficiency, impact, 774–775
 - procedures, 682
 - purchases budget, 727
 - example, 728t
 - standards, 753–755
 - usage budget, 727–728
 - example, 729t
 - variances, 771–774
- Direct method. See Cash flow statement
- Discount
 - cost, 593
 - percentage, 593
 - period, payment, 593
- Discounted cash flow techniques, preference, 486
- Discounted payback period, 465
 - advantages/disadvantages, 488t
 - calculation, 482–483
 - usage, 482–483
- Discount future cash flows, discount rate (usage), 498
- Discount rate, 54, 466. See also Cash flow;
Cross-over discount rate
 - assignment, 492n
 - comparison. See Internal rate of return overstatement, 493
 - usage. See Discount future cash flows
- Discount retail chain, expansion, 457–462
 - analysis, 458–462
 - problem, 457
 - project, worksheet, 462t
- Discount retail chain, net cash flows, 461f
- Discretionary fixed costs, relationship. See Committed fixed costs
- Discretionary fixed expenses, 369
- Disposal costs, 709n
- Disposing assets, cash flow (impact), 439
- Distress. See Financial distress
 - probability, 50
- Distribution, height, 506f
- Dividend, 103–106
 - cutting, 110
 - deduction, 209–210
 - features, 116–117
 - payment, 111–112
 - payout, equation, 103n–104n
 - policy, 106–108
 - puzzle, 112n
 - reset spread, 117
 - yield, 108
- Dividend irrelevance theory (Miller-Modigliani development), 107, 108
- Dividend-paying stocks, volatility, 109
- Dividend reinvestment plan (DRP), 103
- Dividends per share, equation, 103
- Dividends-received deduction, 109–110
 - usage, 208–210
- Divisional income statement, 369
- Dixit, Avinash K., 519n
- DOL. See Degree of operating leverage
- Domestic transfer pricing, 419
- Dorman, Sandra B., 493n
- Doubles, production, 756
- Dow Jones Sustainability Index (DJSI), 14n
- DPO. See Days payables outstanding
- Dravid, Ajay, 106n
- DRP. See Dividend reinvestment plan
- Drug industry. See U.S. drug industry
 - noncyclical industry, 293
- DSI. See Days sales in inventory
- DSO. See Days sales outstanding
- DTL. See Degree of total leverage
- Dual currency bonds, 74
- Dual transfer pricing system, 418–419
- Dugan, Michael T., 327
- DuPont system, 268–271
 - application, 272f
- Earnings before interest, taxes, depreciation, and amortization (EBITDA)
 - calculation, 310–311
 - measure, 325
- Earnings before interest and taxes (EBIT), 264, 280
 - inclusion, 288
 - solution, 287–288
- Earnings per share (EPS), 27–28
 - indifference points, 29–30
 - interaction, 113
 - negative level, 107
 - operating earnings, relationship, 30f
 - swing, 28
- Earnings quality, 323
- Earnings ratio, 376–380
 - equation, 377, 392
 - introduction, 378
- Eastman, Kent, 310n
- EBIT. See Earnings before interest and taxes
- EBITDA. See Earnings before interest, taxes, depreciation, and amortization

- Economic conditions, impact, 498
- Economic life, 434
ranking, 485f
- Economic Order Quantity (EOQ) model, 602–603
considerations/goals, 604–605
- Economic profit, 185–186
value-added measures, 184–185
- Economic profit/economic value added, 185–186
- Economic value added (EVA), 11t. See also Refined economic value added
usage, 184–186
- Efficiency, impact. See Direct materials
- Efficiency variance, 659
usage, 785–786
- EI. See Employee involvement
- EICPs. See Executive incentive compensation plans
- 8-K filing, 9t
- Electronic collection, 586
- Electronic Data Systems (EDS), acquisition, 102
- Embedded derivatives, 124
- Employee
morale, 388
retention/promotability, 388
taxes, problems, 642–643
- Employee involvement (EI), 604
- Employer taxes, fringe benefit costs (problems), 643–644
- Employment taxes, 197
- Ending inventories budget, 730
example, 733t
- End-of-the-period investment center performance, 381
- Energy, hazards, 230
- Enron, scandals, 227
- Enterprise Resource Planning (ERP), 607
- Enterprise risk management (ERM), 230–235
definitions, 231–232
process, 232–233
risk objectives, 233
themes, 233–234
theories, 233–234
- Environmental hazards, 230
- Environmental Protection Agency (EPA), requirements imposition, 435
- EOQ. See Economic Order Quantity
- EPS. See Earnings per share
- Equal-weighting competitors, 305n
- Equipment
disposal, 539–540
leases, types, 533–535
leveraged lease, 546
lessor, involvement, 547
tax basis, 459f
- Equipment obligation/trust debt, 77
- Equity
beta, translation, 509
contrast. See Debt
cost, 55
multiplier, 270
participants, involvement. See Leveraged lease
- Equity capital components, market value, 49f
- Equity funding, 99
conclusion, 121–122
- Equity-linked structured notes, 146–149
- Equivalent annual annuity method, 486
- Equivalent loan
concept, 566–567
representation, 567t
- Equivalent production, 686–688, 691
- ERM. See Enterprise risk management
- Ernst & Young, report, 198–200, 198n
- ERP. See Enterprise Resource Planning
- Escalation clauses, 545
- Escapable costs, 417n
- Escudero, J., 631n
- Estimated costs, 750
- Euro, currency, f236–237
- Eurobonds, 73
- European option, 245
usage, 519
- EVA. See Economic value added
- Evaluation plans. See Finishing Department
- Evans, Nick, 559n
- Ex ante flexible budget. See Assembly department
example, 370t
- Excess capacity, relationship. See Idle capacity
- Excess spread, 131
- Exchange-traded options, OTC options (contrast), 245
- Excise taxes, 197
- Executive incentive compensation plans (EICPs). See Group-based EICPs
dysfunctional decision making, impact, 347–351
example, 348–350
motivation, 349

- Executive incentive compensation plans
(*Cont.*)
necessity, 350
theoretical overview, 347–348
usage, 348
- Executive stock options, usage, 10n–11n
- Executory costs, 544n
- Exercise price, 244, 520
- Exercise style, 519n
- Expansion projects, 434, 435
- Expected cash flows, 472. *See also* Assets
- Expected performance, 355, 394
- Expected productive capacity, 649
usage, 650–651
- Expected return, calculation, 503t
- Expected value, 502
- Expenses
change, 444–445
controllable items, 360
forecast, 448
- Expiration date, 244
- Extendible bonds, 140n
- External credit enhancement, 136–137
- External financial statements, relationship.
See Direct costing
- Fabozzi, Frank J., 123n, 184n, 250n, 548n, 553n
- Facility lease, 543
- Factor, 91
- Factoring, 91. *See also* Conventional factoring; Maturity factoring
- Factory costs, 623t
- Factory employees, vacations (entitlement), 644
- Factory overhead, 346, 635, 671–672.
See also Product elements; Total factory overhead
accounts chart, 658t
actual costing, normal costing (contrast), 647–648
analysis. *See* Overapplied factory overhead; Underapplied factory overhead
application, equations, 653–656
application rates, 650t
determination, 653–656
balance, 660
budget, 653t
example, 731t–732t
usage, 729–730
conclusion, 664–665
control account, 671
distribution, 672
journalizing, 659
procedures, 683
standards, 758–760
usage, 613
variances, 778–786
one-factor analysis, 780–781
three-factor analysis, 784–786
two-factor analysis, 781–784
- Factory overhead costs, 646–660. *See also* Actual factory overhead; Applied factory overhead; Fixed factory overhead; Mixed factory overhead costs; Variable factory overhead
assumption, 687
charge, 673–674
estimates, preparation, 758–759
estimation, 652–653
- Fahey, Liam, 158n
- Fair value hedge accounting treatment, 240
- Farm Equip Corporation
collateral, senior-subordinate structure, 138–139
consideration, 130
repayment, 125
- Farm Equipment Asset Trust (FEAT), 126, 128
- FASB. *See* Financial Accounting Standards Board
- FBI. *See* Federal Bureau of Investigation
- FCF. *See* Free cash flow
- FCPA. *See* U.S. Foreign Corrupt Practices Act
- FEAT. *See* Farm Equipment Asset Trust
- Federal Bureau of Investigation (FBI) report, 494
- Federal corporate tax rates, 205–207
- Federal Insurance Contributions Act (FICA), 643f
- Federal Reserve System, 12 CFR 208/225, 81n
- Federal Unemployment Tax Act (FUTA), 643
- Fédération Internationale de Football Association (FIFA), 253
- Feedback mechanisms, providing, 187
- FEI Canada. *See* Financial Executives International Canada
- Fernandez, R., 631n
- Fiduciary duty. *See* Board of directors; Chief Financial Officer
- Field, Anne R., 235n
- Field, Laura Casares, 46n
- Field warehouse loan, 92
- FIFA. *See* Fédération Internationale de Football Association

- FIFO. See First in first out
- Fin 46, 94–95
- Financial accounting risk, 201, 204
- Financial Accounting Series, SFAS No. 156, 129n
- Financial Accounting Standards Board (FASB), 48
- financial accounting rules, changes, 83
- Interpretation No. 46, 94, 560
- leasing project, 536n
- No. 133, 239
- Statement No. 13, 538, 543, 559
- Statement of Financial Accounting Standards No. 76, 79
- Statement of Financial Accounting Standards No. 150, 81n
- Financial advisers, 541–542
- absence, 572–573
- necessity, 571–573
- services, 571–572
- Financial analysis, cash flow (usefulness), 322–327
- Financial calculator, usage, 468n
- Financial disclosures, enhancement, 3t
- Financial distress, 19
- capital structure, relationship, 40–41
- cost, 37–38, 52
- absence, 56–57
- ignoring, 512n
- present value, 40–41
- relationship. See Capital structure
- effect, CFO assessment, 40
- expected costs, PV (equation), 510
- relationship. See Capital structure
- taxes, absence, 56–57
- Financial Executives International Canada (FEI Canada), survey, 192
- Financial flexibility, relationship. See Leverage
- Financial guarantees, 238–239
- Financial leverage, 19, 263
- impact, 54
- ratios, 284–289
- relationship. See Capital structure; Market risk
- risk, relationship, 29–31
- usage, 507
- Financial model, relationships, 179
- Financial modeling, 179–183
- Financial planning, 153
- budgeting, relationship, 158
- conclusion, 195
- importance, 158–159
- Financial ratio, 421
- Financial ratio analysis, 261
- conclusion, 307–308
- usage, 290–292
- Financial reporting purposes, earnings (acceleration), 129–134
- Financial risk, 229
- increase, 46
- relationship. See Leverage
- Financial slack, 30
- Financial statement
- adjustment, 807
- analysis, 289–290
- Financing. See Secured financing; Unsecured financing
- activities, 742
- agreement, 554
- costs, 624
- non-notification/notification plan, 91
- projections, 174
- sources. See Capital
- Finished goods, quality standards, 763
- Finishing Department
- evaluation plans, 363t
- flexible budget, 361t
- Finite insurance, 254–255
- Fink, Ronald, 81n
- Firm commitment, 73
- Firm value, 54, 61f
- First in first out (FIFO), 388
- costing, 693
- comparison. See Weighted average costing
- Fishbeck, Paul S., 540n
- Fitch, 134–136
- Five forces. See Porter
- Fixed asset turnover ratios, 284
- Fixed charge coverage ratio, 287–288
- Fixed costs, 23f. See also Unitized fixed costs
- decrease, 362
- pattern, 618f
- relation, 22
- usage, 617–621
- Fixed costs per unit, pattern, 619f
- Fixed factory overhead
- application rates, 657
- costs, 647
- Fixed/fixed currency swaps, 247–248
- Fixed-rate basis, 146–147
- Fixed-rate bond
- floating-rate bond, contrast, 84–85
- issuance, 85
- synthetic creation, 84

- Fixed standard, 752
Flat tax rate, 460
Flexible budget, 171–172, 758–759. See also
 Finishing Department
 example, 779t
 period, initiation, 367
Float, 585
Floating lien, 92
Floating rate, 64
Floating-rate bonds, contrast. See Fixed-rate
 bond
Floor
 agreements, 248–249
 planning, 92
Ford Motor Company, privately held corpo-
 ration, 102
Forecasting. See Sales forecasting
 regression analysis, usage, 162
Foreign tax credit, 219
Forrester, Jr., J.R., 489n
Forward contracts, 243–244
Forwarding hedging contracts, 243n
Foster, Benjamin (study), 327
Fowkes, David, 558n
Free cash flow (FCF), 316–318. See also Net
 free cash flow
 calculation, 318–320
 contrast. See Net free cash flow
 estimate, 319
 generation, 317
 impact. See Positive free cash flow
 measure, 325
 perception, 319
 theory, development, 316–317
Fridson, Martin, 314, 325n
Frigo, Mark L., 10n, 192n
Fringe benefit costs, problems. See Employer
 taxes
Full costing, 791
Full lease payment, 533–534
Full-payout leases, operating leases (con-
 trast), 535–536
Full-payout-type leases, 541
Full restructuring, 251n
Fully amortizing loan, 65–66
 assumption, 68
Functional approach. See Company
 flowchart, 333f
 usage, 332–334
Functional area classification, 624–625. See
 also Costs
Funding costs, reduction (potential), 127–129
Funding sources, diversification, 129
FUTA. See Federal Unemployment Tax Act
Future cash flows
 uncertainty, 482
 understatement, 493
Future minimum lease payments, 545
Future outcomes, dispersion, 501
Futures contracts, 241–243
 contrast. See Options
 mechanics, 242–243
 risk/reward characteristics, 246
Garntner Group, TCO concept proposal,
 494
Garvin, David, 491n
Garvy, Gerald T., 47n
Generally accepted accounting principles
 (GAAP), 7
 rules, 94
General Motors Acceptance Corporation
 (GMAC), 89
General Motors (GM)
 dividends, increase, 107n
 EDS spinoff, 102n
Geographical approach. See Company
 flowchart, 336f
 usage, 334–337
Gitman, I.J., 489n
GlaxoSmithKline, IRS settlement, 421–422
GMAC. See General Motors Acceptance
 Corporation
Goal congruence, 330, 419
 absence, 349–350
 usage, 407
Goals/performance, exceptions (reporting),
 340
Gompers, Paul A., 103n
Goods/services
 demand, 595–596
 economic value, objective measure, 414
 price elasticity, 596
Goodwill, 207
Government Performance and Results Act of
 1993, 186n
GPR. See Gross profit ratio
Graham, John, 489n, 491n, 493n, 526n
Grant, James L., 184n
Grassroots approach, 723
Grinblatt, Mark, 106n
Gross profit
 analysis, 394–404
 multiple products, 398–404

- Gross profit (*Cont.*)
 change, 395
 analysis, 395–398
 margin, 279
 statement. See Actual Gross Profit Statement; Budgeted Gross Profit Statement
 variance, three-factor analysis, 397
- Gross profit ratio (GPR), 396
- Group-based EICPs, 349
- Gry, Tara, 103n
- Guaranteed wages, 646
- Guideline lease, 534
- Hackett-REL Consultancy Group, 589
- Half-year convention, 211
- Hall, Martin, 600n
- Hanka, Gordon, 47n
- Harvey, Campbell, 489n, 491n, 493n, 526n
- Hawkins, Chuck, 156n
- Hayes, Robert H., 491n
- Hell-or-high-water clause, 554
- Higgins, John A., 339n
- Hostile takeover, 46
- Human hazards, 230
- Hundal, M.S., 631n
- Hybrid securities, 80–82
- IASB. See International Accounting Standards Board
- IBM, manufacturer-lessor (example), 539
- Ideal productive capacity, 649
- Ideal standard, 752–753
- Ideal transfer price, 417n
- Idle capacity
 excess capacity, relationship, 651
 variance, 782–784
- Idle time, result, 645–646
- ILNs. See Insurance-linked notes
- Import/export taxes, 198
- Imposta Regionale sulle Attivita Productive (IRAP), 221n
- Income
 period charge, 625–626
 taxation, minimization, 419
 taxes, 197
- Income distribution, 33
- Income statement
 analysis, 289–290
 differences, 796–797
 example, 798t, 800t, 801t
 usage, 796–801
- Incoming cash, acceleration methods, 585–588
- Incremental cash flows, 437–438, 464
- Incremental common costs, 371
- Incremental cost, 626
- Indemnity, contract, 237
- Indenture agreement, 71
- Indentures, 71
- Indenture trustee, involvement. See Leveraged lease
- Independent project, 436
- Indexed inverse floater, 145
- Index swaps, 250
- Indirect costs, 60, 623
- Indirect manufacturing costs, accumulation, 646
- Indirect materials, 636
- Indirect method. See Cash flow statement
- Individuals, motivation, 340
- Initial margin, 242
- Inspection
 quality standards, 763
 time, 766
 reduction, 768
- Installment sales contracts, 131
- Insurance. See Traditional insurance policies; Commercial insurance policies; Corporate insurance policies
- Insurance-linked notes (ILNs), 253
- Intercompany transactions, transfer prices (relationship), 223
- Interest. See Bonds
 deductibility, tax-shield, 510
 expected risk-free rate, 510
 expense, 222–223
 payments, 147
- Interest-bearing account, 254
- Interest-bearing debt, 49f
- Interest coverage ratio, 287
- Interest deductibility, capital structure (relationship), 32–34
- Interest deduction, 37
- Interest expense
 deduction, 210–211
 shield, 34–35
- Interest-only strip, 131
 impact, 134n
 valuation, 132–133
 value, 133
- Interest rate
 environment, 142
 impact, 498
 prevalence, 86
 reset formula, 64

- Interest rate (*Cont.*)
 - swap, 247
 - usage, 84
- Interest-rate linked structured notes, 144–146
- Interest tax shield, 34–35
 - value, decrease, 36–37
- Interim cash flow, 244
- Internal auditing, system, 340
- Internal credit enhancement, 136–137
 - advantages, 139
- Internal rate of return (IRR), 465. See also Modified internal rate of return; Multiple internal rate of return
 - advantages/disadvantages, 487t
 - capital rationing, relationship, 475–476
 - defining, 473
 - discount rate, comparison, 569
 - increase, 485
 - mutually exclusive projects, relationship, 474–475
 - usage, 472–477
- Internal Revenue Code (IRC), 205
 - allowance, 210
 - lease requirements, 556–557
 - Section 482, 423–424
 - Section 6662, 422
- Internal Revenue Service (IRS), 205
 - regulations, impact, 806
 - reporting requirements/regulations, 7
 - tax requirements, 547n
- International Accounting Standards, convergence, 302
- International Accounting Standards Board (IASB), 81
 - leasing accounting review, 536n
- International conditions, impact, 498
- International Swap and Derivatives Association (ISDA), 250–251
- International transfer pricing, 419–424
- Intracompany performance, assessment, 354
- Inventive plans, 646
- Inventory. See Days sales in inventory
 - changes, 174
 - control. See Collateral
 - costing, 751
 - costs, association, 602
 - flows, 284
 - holding, reasons, 601
 - levels, example, 606
 - turnover ratio, 282
 - usage, 605
 - usage, 91–93
- Inventory management, 282, 601–607
 - models, 602–605
 - monitoring, 605–606
 - practice, 606–607
- Inverse floaters, 145
- Investment
 - activities, 742
 - cash flow, 438–441
 - cash flow, impact, 437–454
 - decision, 430–432
 - disposition, 441–442
 - low-risk type, 458
 - opportunities, 463–464
 - options, 518
 - timeline, 473f
 - problem, 430–432
 - profile, 469–471
 - illustration, 469f, 470f
 - proposal, consideration, 383
 - requirement, 434
 - risk, payback period (usage), 482
 - strategy, 154
 - tax credit, 438n
 - turnover, 376–380
 - equation, 377
 - introduction, 378
- Investment banking firm, trading desk, 147n
- Investment center, 341
 - charging, 384
 - decision making, 390–394
 - performance evaluation, 373–394
- Investment center managers
 - budget comparison, 355
 - decision-making authority, 373–374
 - performance, measurement, 380
 - proposal
 - acceptance, 386–387
 - rejection, 387
 - ROI formula, expansion, 378
- Investment projects
 - classification, 432–437
 - economic life classification, 432–434
 - risk classification, 434–435
- Investment tax credit (ITC), 216
- Investors
 - motivation, 142–143
 - sophistication, 72
- Invoices, usage, 658
- IRAP. See Imposta Regionale sulle Attivita Produttive
- IRC. See Internal Revenue Code
- IRR. See Internal rate of return

- Irrelevant costs, relationship. See Relevant costs
- ISDA. See International Swap and Derivatives Association
- Ishii, Joy, 103n
- Issuers, responsibilities, 71
- Issues, calling, 78
- ITC. See Investment tax credit
- Ittner, Christopher D., 190n
- Jandik, Tomas, 47n
- Jensen, Michael, 13n, 31n, 39n
 observations, 316–317
- JIT. See Just-in-time
- Job order
 cost accumulation systems, process cost accumulation systems (comparison), 668–669
 costing, 667
 conclusion, 695–697
 systems, process costing system (comparison), 670f
 usage, 669–673
 cost sheet, 672
 cost system, standards (establishment), 760–761
 waste material, presence, 697
- Jobs & Growth Tax Relief Reconciliation Act of 2003, 109n
- Joint costs
 allocation, 708–710
 impact, 715–716
 split-off point, 704–705
- Joint manufacturing process, example, 705f
- Joint products, 703–711
 accounting, 705–711
 costing, 703
 conclusion, 716–717
 physical relationship, 704
- Junior bond, 77
- Just-in-time (JIT) inventory
 model, 603–604
 considerations/goals, 604–605
 system, 6800682
- Just-in-time (JIT) philosophy, 764–769
 adoption, 765
 manufacturing elements, 766t
- Kahn, Nasir, 558n
- Kaplan, Robert S., 11n, 187n, 348n, 349n, 492n, 662n
- Karpoff, Jonathan M., 46n
- Katz, David M., 254n, 589n
- Kaufman, Robert J., 493n
- Kersner, Janet, 189f
- Key performance indicators (KPIs), 188
- Koch, Christopher, 607n
- Koller, Tim, 184n
- KPMG
 Corporate Tax Rate Survey, 221n
 tax department survey, 199n
- Krispy Kreme, synthetic lease, 559–560
- Labor, 635, 641–646
 accounting, 641–642
 problems, 642–646
 conclusion, 664–665
 costs, 641, 671–672
 cycle, 643f
 hours, allowance, 783
 job tickets, preparation, 642
 timekeeping, 641–642
 total payroll, computation, 642
- Larcker, David F., 190n
- Largay III, J.A., 326n
- Last in first out (LIFO), 388
- Lean production, 765n
- Learning curve, 756
 computations, example, 757t
 example, 757f
- Lease. See Leveraged lease; Net lease; Triple-net lease
 brokers, 541–542
 capitalization, 543
 classification, 543–544
 comparison, 568
 decision, 560–574
 expenses, impact, 280
 NPV, representation, 569f
 obligation, off-balance-sheet treatment, 559
 payment. See Full lease payment; Future minimum lease payments; Total contingent lease payments
 present value, 544
 periodic payments, 561
 programs, 542–543
 transactions, lessee financial reporting, 543–546
 true lease qualification, 557–558
 types. See Equipment
 valuation, 560–574
 approach, alternative, 568–570
 value (determination), worksheet (usage), 566t
- Leasing, 531
 arrangements, example, 568

- Leasing (*Cont.*)
 - conclusion, 574–577
 - cost, reduction, 534, 536–537
 - impact. See Book earnings; Cash flow;
 - Direct cash flow
 - management restrictions, 540
 - process, explanation, 532–533
 - reasons, 536–541
 - transaction, IRS awareness, 534
- Legal commitment, 319
- Legal costs, 60
- Legal risk, 229
- Lenders, involvement. See Leveraged lease
- Leone, Marie, 203n, 601n
- Lessee, 531
 - financial adviser, duties, 571n
 - financial reporting. See Lease
 - financial statement, 545
 - indemnities, 555
 - satisfaction, 572–573
 - tax shield, forgoing, 561
 - true lease, usage (advantage), 534
- Lessor
 - economic result, achievement, 547n
 - involvement. See Leveraged lease
 - payout-type leases, structure, 538–539
 - risk, 551n
 - types, 541
- Letter of credit (LOC), 239
- Leverage
 - concept, 21–25
 - degree, 22, 24
 - break-even point, 24f
 - effect, 29–30
 - financial flexibility, relationship, 30–31
 - financial risk, relationship, 25
 - fixed costs, relationship, 23f
 - operating risk, relationship, 24–25
- Leveraged lease, 532
 - cash flows, 555–556
 - contrast. See Single-investor leases
 - debt, 556
 - documents, 554–555
 - equity participants, involvement, 548–549
 - flowchart, 553f
 - fundamentals, 546–556
 - guarantor, involvement, 551
 - indenture trustee, involvement, 550
 - involvement, 547
 - legal expenses/closing costs, 547
 - lessee, involvement, 548
 - lessor, involvement, 535
 - loss participants/lenders, involvement, 549
 - manufacturer/contractor, involvement, 551
 - owner trustee, involvement, 549
 - packager/broker, involvement, 551
 - participation agreement, usage, 554
 - parties, involvement, 548–551
 - structure, 551–552
 - structuring/negotiating/closing, steps, 573–574
 - transaction, closing, 554–555
 - true lease, comparison, 535, 547
- Liability insurance, 238
- LIFO. See Last in first out
- Limited liability
 - possession, 38
 - role, 38–39
- Line of credit, 88
- Liquidation value, 116
- Liquidity, 263
 - measures, 276–278
 - operating cycle, relationship, 273–276
 - ratios, 278–279
 - down trend, 326
 - usage, 271–279
- Loan
 - originator, 125
 - participants
 - benefits, 550
 - involvement. See Leveraged lease
 - payments, 566n
- LOC. See Letter of credit
- Local taxes, 218
- Lockboxes, advances, 588
- Lockbox system, 585
 - timeline, correspondence (example), 587f
 - usage, 586–588
- London Interbank Offered Rate (LIBOR), 64
 - basis points, inclusion, 84
 - payment, 247
 - rates, quoting, 88
 - reference rate, 70
 - usage, 145n
 - usage, 519n
 - value, 249
- Long futures, 241–242
- Long position, 241–242
- Long-run planning (long-term planning), 159
- Long-run productive capacity, 649
- Long-term assets, investments (evaluation), 465
- Long-term debt
 - changes, 174
 - covenants, 175–176

- Long-term financial planning, 179
- Long-term financing, 542
- Long-term issues, refunding restrictions, 78
- Long-term planning, 180t–181t
- Lower-level managers, post-hoc reports, 355
- Low-interest bearing, 88

- Maccarone, Paolo, 632n
- Machine hours, estimation, 656
- MACRS. See Modified Accelerated Cost Recovery System
- Maintenance margin, 242–243
- Majluf, Nicholas S., 40n
- Majority-owned subsidiaries, accounting data, 48
- Makhija, Anil, 47n
- MAN. See Materials as needed
- Management Advisory Services, 802
- Management analysis, 404
- Management by exception principle, 773
- Management control, impact, 805
- Management forecasts, 163
- Management risk, 201, 204
- Managers
 - decision making, distribution, 337
 - fringe benefits, 44
 - initiative, exercising, 338
 - motivation, 337
- Mandatory convertible preferred stock, 118
- Manufacturing budgets, cost, 727–732
- Manufacturing costs, 624
- Manufacturing division, operations, 332
- Manufacturing elements, 766t
- Margin, 376–380
 - requirements, absence, 245
- Marginal tax rate, 35
 - consistency, 48
 - graph, 207f
 - increase, 47
 - level, 451–453
 - ratio, 206
- Marine hull, insurance, 238
- Marketable securities, 589–591
 - investment, risks (association), 590t
 - risk, relationship, 590
 - types, 590–591
- Market conditions, impact, 498
- Market efficiency, 83
- Marketing costs, 624
- Market liquidity risk, 229
- Market price, 414–418. See also Synthetic market price
 - usage. See Outside market price
- Market risk, 229. See also Creditors compensation, 500
 - equation, 515–516
 - financial leverage, relationship, 507–509
 - measurement. See Projects premium, 510
- Market share, 387
- Market surveys, 162–163
- Market value
 - contrast. See Book value definition, 286
- Market value added (MVA), 184–185
 - usage, 186
- Market value at split-off method, 705
 - advantage, 711
 - usage, 708
- Markowitz, Harry M., 232n
- Marshall, Alfred, 185n
- Master budget, 719
 - conclusion, 744–748
 - development, 722–723
 - schedules, 721f
 - system. See Conventional master budget system
- Masulis, Ronald, 106n
- Material Requirements Planning (MRP), 607
- Materials. See Direct materials; Indirect materials
 - accounting, 636–638
 - periodic inventory system, 639
 - perpetual inventory system, usage, 639–640
 - systems, 639–640
 - control procedures, 640
 - issuance, 638–639, 671
 - purchase, 636–638, 670
 - stores, 636–640
- Materials as needed (MAN), 680
- Materials costing/control, 635
 - conclusion, 664–665
- Mathias, Alex, 253n
- Maturity
 - customization factors, 144
 - factoring, 91
 - profile factor, 141t
- Maturity date, 74
 - bond issue, retirement, 82
- McConville, Daniel J., 325n
- McLannahan, Ben, 600n
- McNichols, Maureen, 106n
- Mechanical hazards, 230
- Meckling, William H., 13n, 31n, 39n
- Medium-rate notes, 85–86

- Medium term, 85
- Medium-term note (MTN), 85–86
 - corporate bonds, contrast, 86
- Merchandise credit, 591–592
- Meredith, Thomas, 606n
- Merger mania, dilemma, 44
- Metrick, Andrew, 103n
- Metrics, usage, 189
- Metros, Pete J., 4n
- Microsoft Corporation, founding, 107
- Middle-level managers, post-hoc reports, 355
- Miller, Merton H., 53n, 110n, 584n
 - theory. See Modigliani-Miller theory
- Minimum inventory production system (MIPS), 680, 682
- Minimum lease payments, 545n
- Minimum ROI, insistence, 391
- MIPS. See Minimum inventory production system
- MIRR. See Modified internal rate of return
- Mixed costs, 621–622
- Mixed factory overhead costs, 647
- Mix variance, 401–402
 - analysis, 403t
- M&M. See Modigliani-Miller theory
- Modern Portfolio Theory (MPT), 232
- Modified Accelerated Cost Recovery System (MACRS), 211–212
 - classified lives, 212t
 - depreciation, 214t
 - rates, 213t, 442n
 - MACRS-accelerated depreciation deductions, 570
 - tax benefits, 546
 - tax depreciation deductions, 548
 - usage, 451, 457
- Modified internal rate of return (MIRR), 465, 477–480
 - advantages/disadvantages, 488t
 - calculation, 478–480
 - decision rule, 480
 - reinvestment rate, relationship, 479f
- Modified modified restructuring, 251n
- Modified restructuring, 251n
- Modigliani, Franco, 53, 53n
- Modigliani-Miller (M&M) irrelevance proposition, 53–57
 - conditions, 54
- Modigliani-Miller (M&M) theory, 53–62
 - impact, 58–59
- Money
 - borrowing, after-tax cost, 570
 - time value, 468
 - risk, separation, 525
- Money market securities, 591t
- Monitoring costs, 45
- Monthly payment, amount, 68t–70t
- Moody's Investors Service, 134–136
- Mortgage, 76–77
- Motivation, impact, 407–408
- Moving tiem, 766–767
- MPT. See Modern Portfolio Theory
- MRP. See Material Requirements Planning
- MTN. See Medium-term note
- Multiline insurance, 255
- Multiple departmental factory overhead application rates, contrast. See Single plant-wide overhead application rates
- Multiple internal rate of return, 476
 - illustration, 477f
- Murrin, Jack, 184n
- Mutually exclusive projects, 436
 - impact, 484
 - relationship. See Internal rate of return
- MVA. See Market value added
- Myers, Stewart C., 40n, 51n, 510n, 518n, 565n
 - APV development, 561n
- NAICS. See North American Industry Classification System
- Nationality, customization factors, 144
- Net cash flows, 451–453. See also Discount retail chain
- Net credit sales, 282–283
- Net free cash flow (NFCF), 320–322
 - FCF, contrast, 320
- Net income
 - equation, 269
 - reconciliation, 744t
- Net interest spread, 131
- Net lease, 532
- Net operating cycle, 276
- Net operating income after taxes (NOPAT), calculation, 186n
- Net operating loss (NOL), 35
 - carrybacks/carryovers, 35n
 - usage, 217–218
- Net present value (NPV), 185, 465, 466–471. See also Static NPV; Strategic NPV
 - advantages/disadvantages, 487t
 - APV, comparison, 513t
 - calculation, 467–468
 - difference. See Adjusted present value equation, 467, 522

- Net present value (*Cont.*)
 indication, 468
 lower level, 492–493
 profile, 469
 projects. See Positive net present value projects
 representation, 522–523
 selection, 474
- Net profit margin, 280–281
- Net realizable value method, 705
 usage, 709–711
- Net working capital-to-sales ratio, 278
- Nevitt, Peter K., 548, 553n
- New cash flow (computation), worksheet (usage), 452t
- New product cost estimation, techniques, 629–633
- NFCF. See Net free cash flow
- Niazi, Adnan, 630n–633n
- NOL. See Net operating loss
- Nomura Research Institute, survey information, 190n
- Noncontrollable costs, 627
- Non-core risks, 230
- Noncumulative dividends, contrast. See Cumulative dividends
- Non-dividend-paying stocks, volatility, 109
- Non-interest-bearing account, 88
- Nonleveraged leases, 546
- Nonlinear payoff, 246
- Nonoperating cash flows, 168
- Nonparticipating stock, contrast. See Participating stock
- Nontax leases, 557n
- Nontax-oriented leases, 533
 classification, 537
 tax-oriented true leases, IRC distinctions, 557
- Non-U.S. taxes, 218–223
- NOPAT. See Net operating income after taxes
- Normal costing, 647, 750
 contrast. See Factory overhead
- Normal defective units, 699
- Normal productive capacity, 649
 usage, 650
- North American Industry Classification System (NAICS), 293n
 SIC replacement, 303–304
- Norton, David P., 11n, 187n
- Notes, 71–86
 obligations, 74
- Notional principal amount (notional amount), 246
- NPV. See Net present value
- Obsolescence, risk, 539–540
- Occupational Health and Safety Agency (OSHA), requirements imposition, 435
- OCFs. See Operating cash flows
- OEA, Inc.
 cash flows, sources, 324f
 financial results, 323–324
 operating/net income, 323f
- OECD. See Organization for Economic Cooperation and Development
- Off-balance-sheet financing, 93–95
 accounting objective, 560
- Off-balance-sheet treatment. See Lease
- Office rent, impact, 280
- Offshore lease programs, 543
- Old restructuring, 251n
- One-factor analysis. See Factory overhead
- Open market purchase, 112–113
- Operating cash flows (OCFs), 62, 443–449.
 See also Projects
 consideration, 449–451
- Operating costing, 673–674
- Operating cycle, 271–276. See also Net operating cycle
 equation, 275, 580
 impact, 580
 relationship. See Liquidity
- Operating earnings, 264
- Operating income
 difference, 797–798
 level, increase, 799
- Operating leases, 536. See also Cancelable operating lease
 accounting, 544
 contrast. See Full-payout leases
- Operating leverage, degree. See Degree of operating leverage
- Operating profit
 calculation, 185
 comparison, 185
 margin, 280
- Operating results, 354–355
- Operating risk, 431
 relationship. See Leverage
- Operational budgeting, 159
- Operational risk, 201, 203, 229
- Operations planning, 803

- Opportunity costs, 60
 - consideration, 444
 - usage, 629
- Optimized debt structures, 555–556
- Optimum transfer price, 417n
- Options, 244–246
 - buyer, 244
 - exercise price, 519
 - expiration, time remaining, 519
 - factors/values, relation, 520t
 - futures contracts, contrast, 246
 - price/premium, 244
 - strike price, 519
 - value, volatility (impact), 524
 - value-added, 523
 - write, grants, 244
- Organization
 - approaches. *See* Company
 - concepts, 330–331
 - development, 330
 - plan, 339
 - structure, 330–331
 - development, 330
 - existence, 340
 - types, examples, 331–337
- Organizational decentralization, autonomy dimension (expense), 348
- Organization for Economic Cooperation and Development (OECD), 223, 420–421
 - Transfer Pricing Guidelines for Multinational Enterprises and Tax Administrations, 421
- Original cost, valuation, 390
- Orr, Daniel, 584n
- OSHA. *See* Occupational Health and Safety Agency
- Oster, Patrick, 156n
- Osterland, Andrew, 607n
- Outcomes
 - dispersion, 501
 - standard deviation, 502
- Outlay costs, 417n
- Outreville, J. Francois, 229n
- Outside market price, usage, 414–415
- Outside purchase. *See* Production department
- Overapplied factory overhead, analysis, 659–660
- Overcollateralization, 138
- Overhead costs. *See* Factory overhead costs
- Over-the-counter market, call option (sale), 83
- Over-the-counter options, contrast. *See* Exchange-traded options
- Overtime premiums, 645
- Owners, wealth maximization, 430–432
- Owner trustee, involvement. *See* Leveraged lease
- Packager
 - bid firm, agreement, 552
 - involvement. *See* Leveraged lease
- Pahl, G., 631n
- Parallel product flow, 680
 - flowchart, 681f
- Parametric cost estimation techniques, 632
- Participating stock, nonparticipating stock (contrast), 116
- Participation agreement, usage. *See* Leveraged lease
- Par value
 - repayment, 77
 - retirement, 77
 - usage, 116
- Patterson, Perry, 4n
- Payback period, 465. *See also* Discounted payback period
 - advantages/disadvantages, 488t
 - usage, 480–482. *See* Discounted payback period; Investment
- Payroll costs, allocation, 642
- Pecking order, 51
 - explanations. *See* Capital structure
- Peng, Scott Y., 140n, 141n, 143n
- People responsibility, 339
- Percent-of-sales method, 176–178
- Performance
 - indicators, 190t
 - measurement, 381
 - strategy/dimensions, relationship, 189f
- Performance evaluation, 408, 419. *See also* Chief Financial Officer; Responsibility center performance evaluation
 - management tools, examples, 11t
 - measurement devices, usage, 187
 - report, example, 370t
 - usage, 183–191
 - variance, calculation, 350t. *See also* Profit center
- Period costs, 626, 626f
- Periodic inventory system. *See* Materials
- Perpetual inventory system. *See* Materials
- Per-unit amounts, 410
- Peterson, David, 110n
- Peterson, Pamela, 110n, 520n
- Pfizer, Inc. (1990-2005)
 - accounting data, usage limitations, 301–303

- Pfizer, Inc. (*Cont.*)
 accounting methods, 301
 differences, 302–303
 accounting principles, changes, 301, 302
 activity ratio, 295–296
 benchmark, selection, 303–305
 classification, 293
 difficulties, 302
 common-size analysis, 299–301
 common-size balance sheet, 301f
 common-size income statements, 300f
 company description, 292–294
 Du Pont
 analysis, 298–299
 components, 299f
 example, 292–307
 expenses, trends, 300
 extraordinary/special items, 302
 factors, 292–294, 299
 financial leverage, 297–298
 ratios, 297f
 financial ratios, 294–301
 forecasting ratio, usage, 305–307
 historical costs, usage, 301, 302
 industry, 292–294
 inventory investment, 295
 LIFO/FIFO selection, 304–305
 liquidity ratio, 294–295
 bar chart, 295f
 merger-related activities, 296–297
 net income
 error, forecasting, 306f
 forecasting, 306f
 trends, 300
 profitability ratio, 296–297
 profit margins, 296f
 ratios, selection/interpretation, 303
 R&D expenses, 300f
 R&D spending, 299
 restatements, 302, 304
 return, 298–299
 returns on investment, 298f
 seasonality, 294
 turnover ratio, 296f
 Physical capacity, 649
 Physical flow, schedule accounts, 684–686
 Physical output method, 705
 usage, 707–708
 PI. See Profitability index
 Pindyck, Robert S., 519n
 Pinto, Roberto, 632n
 Pipeline investment, 629
 Plain-vanilla bonds
 offering, 143
 structures, 140
 Planned costs, 750
 Planning
 costs, relationship, 626–629
 function, 393–394
 Plant managers
 level 2, 343
 responsibility level, 331
 Plants, level 2, 342
 PLRs. See Private letter rulings
 Point of indifference, determination, 362
 Poison puts, 80n
 Poli, C., 631n
 Porter, Michael, 193
 five forces, 193f
 Portfolio risk, 201, 204
 Portfolio/synthetic collateralized debt obligations, 250
 Position to market, marking, 242
 Positive free cash flow, impact, 317–318
 Positive net present value projects, 316
 Post-payback duration, 481
 Powers, Jr., William C., 2n
 Practical productive capacity, 649
 Predicted costs, 750
 Preferred shareholders, 115
 Preferred stock, 115–120
 callability, 118–119
 convertibility, 118
 corporate use, 120
 dividends, payment, 288
 features, 116–120
 packaging features, 119–120
 riskiness, 42
 sinking funds, 119
 voting rights, 119
 Premiums. See Overtime premiums
 payment. See Shift premiums
 Prepayment, 131
 Present value. See Adjusted present value
 equation. See Financial distress
 President
 level 4, 342, 345
 responsibility level, 331
 salary, cost control, 332n
 Price. See Market price; Transfer prices
 negotiation, 413–414
 variance, 659
 calculation, 772
 usage, 784–785

- Price-efficiency variance, combination, 775
- PricewaterhouseCoopers (PWC), tax risk suggestion, 201
- Prime costs, 615, 636
conversion costs, relationship, 616f
- Prime rate, 88
- Principal, 64
fixed amount, 140
- Principal-agency relationship, 348, 350
- Principal-agency theory, 347–348
- Private letter rulings (PLRs), 203
- Privately held corporation, 100
- Privately held shares, publicly held shares (contrast), 100–101
- Private placement, 72
- Probability distribution, 171–172
- Process cost accumulation systems, comparison. See Job order
- Process costing, 667, 676–694
conclusion, 695–697
objectives, 676–677
system, comparison. See Job order
waste material, presence, 697
- Process cost system
characteristics, 677
costs, accumulation, 678f
objective, 677
procedures, 682–683
standards, establishment, 760–761
- Processing time, 766
- Procter & Gamble
cash flow
adjustment, 312–313
estimate, 310
pattern, consistency, 313–314
relationship, 318n
depreciation/amortization, 319n
FCF, calculation, 321t–322t
losses, 239n
property, plant, and equipment, 318
- Product approach. See Company
- flowchart, 335f
organization chart, 356f
usage, 334
- Product costs, 625, 626f
estimation techniques. See New product
cost estimation
- Product elements, 612–615
factory overhead, 613
flowchart, 612f
labor, 613
list, 615t
- Product flow. See Parallel product flow;
Selective product flow; Sequential product
flow
flowchart, 681f
- Production
budget, 725–726
schedule, 726t
flow, example, 706f
level, estimation, 648–649
processes, quality standards, 763
units, estimation, 654
volume, 783
- Production costs
example, 613–614
list, 614t
relationship, 615–616
- Production department
costs, 624
outside purchase, 346
- Production report, cost, 683–694
departments, 684–693
example, 685t, 690t
- Production volume variance, 659
occurrence, absence, 797
usage, 782–784, 786
- Productive capacities, comparison, 649–651
- Productivity ratios, 387
- Product pricing, 752
impact, 805
- Profitability, 263
ratios, 279–281
down trend, 326
- Profitability index (PI), 465, 471–472
advantages/disadvantages, 487t
direct solution, absence, 472n
equation, 472
lower level, 492–493
- Profit center, 340–341
accommodation, 415
decision making, 372–373
example, 341
incomes, relevance, 410, 411, 413–415
manager, 372
budget comparison, 355
performance evaluation variance, calculation, 350
performance
evaluation, 364–372
evaluation, variables (impact), 365
variable administration expenses (determination), worksheet (usage), 368t

- Profit center (*Cont.*)
 variable/fixed selling expenses (determination), worksheet (usage), 367t
 welfare, overemphasis, 413–414
- Profit margin ratios, 279
- Profit split method, 421
- Pro forma balance sheet/income statement, 175t
- Pro forma financial statements
 balance sheet, 182t
 percent-of-sales method, usage, 177t–178t
 usage, 172–179
- Pro forma financial statements, usefulness, 160
- Program planning, budget system (relationship), 722
- Project risk, 498–500
 assessment, 526–528
 coefficient of variation, relationship, 502–504
 measurement, 500–505
 outcomes, dispersion, 501
 range, 501–504
 standard deviation, relationship, 501–502
 types, 499–500
- Projects. See Complementary projects; Contingent projects; Independent project; Investment projects; Mutually exclusive projects
 capital cost, 511
 CAPM basis, 515–516
 WACC, contrast, 527t
 costing, 674–676
 mandate, 435
 market risk, measurement, 505–514
 NPV, 523
 OCF, 437
- Property damage, 238
- Prospectus, usage, 9t
- Proxy statement (Schedule 14A), 9t
- Pseudodecentralization, 406
- Public Company Accounting Oversight Board, 3t
- Public corporation, consideration, 100
- Public Law (PL) 101-576. See Chief Financial Officers Act of 1990
- Public Law (PL) 107-204, 2n
- Publicly held corporation, 100
- Publicly held shares, contrast. See Privately held shares
- Publicly Traded Companies, filings (summary), 9t
- Purchase. See Materials order, 637
 flowchart, 638f
 requisition, 636–637
 flowchart, 638f
- Purchase option, renewal (existence), 545
- Purchase price, assumption, 411
- Purchases, days (calculation), 166
- Pure direct materials, 775
- Pure-play
 asset beta, estimation (usefulness), 509n
 usage, 509
- Pure volume variance, 401
 analysis, 402t
 computation, 402–403
- Puttable bonds, 79–80, 140
 design, 80n
- Put option, 244, 521
- Put provision, 79–80
- Qualitative techniques, 630–631
- Quality
 control
 department, usage, 764
 policies/objectives, 762–763
 costs, 761. See also Cost of quality
 definition, 765t
 definitions, 761–762
- Quantitative techniques, 630–631
- Quantities, counting, 684–686, 689
- Quarterly revenues, 164
- Queue time, 767
 reduction, 768
- Quick ratio (acid-test ratio), 277
- Quoted margin, 64
 equation, 144
- Raigopal, Shiva, 491n
- Randall, Taylor, 190n
- Rate profile, customization factors, 144
- Rating agencies, 134–136
- Ratios
 analysis, 324–325. See also Financial ratio analysis
 classification, 262–264
- Real assets
 options, 519–520
 stock/option, 520t
- Real estate value-added taxes, 218
- Realistic productive capacity, 649
- Real options, 518–525
 challenges, 524–525
 example, 520–524

- Real options (*Cont.*)
 - list, 521t
- Real options valuation (ROV), 518
- Reason, Tim, 560n
- Receivables. See Accounts receivable
 - aging, 165
 - assignment, 91
 - management, 591–601
 - sale, 91
- Receiving report, 637–638
 - flowchart, 638f
- Reconciliation method, 742–743
- Record-keeping, 752
- Recovery period. See Capital
- Reference asset, 251
- Reference entity, 250
- Reference issuer, 251
- Reference obligation, 251
- Reference rate. See London Interbank Offered Rate
 - equation, 144
- Refined economic value added (REVA), 184
- Refunding restrictions, 78
- Registration statements, usage, 9t
- Regulations. See Securities and Exchange Commission
- Reinvestment rate
 - relationship. See Modified internal rate of return
- Reinvestment rate assumption, 477–478
- REL Consultancy Group, 589
- Relevance, characteristic, 360
- Relevant costs, 417n
 - irrelevant costs, relationship, 626
- Remarketed preferred stock, 117
- Remote disbursement, impact, 586
- Repetitive Manufacturing System, 765n
- Replacement projects, 434, 435
- Reputational risk, 201, 204–205
- Required rate of return (RRR), 431, 466
- Resale minus method, 421
- Research and development, failure, 522
- Reserve account, 138
- Reserve funds, 139
- Reset date, 64
- Reset period, 64
- Residual income (RI), 384–388
 - amount, calculation, 392–393
 - equation, 374
 - formula, 385f
 - maximization, 384, 386
- Residual loss, 46
- Residual value, anticipation, 536
- Responsibility
 - levels, 342f
 - reports, 344t
- Responsibility accounting, 329, 338–345
 - conclusion, 350–352
 - definition, 339
 - reports, 343–345
 - system, 341–342
- Responsibility centers, 340–341
 - comparison, 354–356
 - performance evaluation, 353
 - measures, conflicts, 490–491
- Restructuring, absence, 251n
- Retail chain, expansion. See Discount retail chain
- Retail price method, 421
- Retained earnings, changes, 174
- Retained risk, 236. See also Unfunded retained risk
- Return on assets (ROA), 27–28
 - equation, 265–266, 269–270
 - ratio, 265
- Return on equity (ROE), equation, 267, 270
- Return on investment (ROI), 263
 - equation, 374, 376
 - expectation, 376
 - explanation, 375–384
 - formula
 - expansion. See Investment center managers
 - factors, 379f
 - goal congruence, absence (example), 382–384
 - insistence. See Minimum ROI
 - problem, 381–382
 - ratios, 264–271
 - equations, 267–268
 - strengths, 380–381
 - usage, 383
 - weaknesses, 380, 381
- Return ratio, 263
- REVA. See Refined economic value added
- Revenue Procedure 75-21, 551n
- Revenue Ruling 55-540, 557
- Revenues
 - change, 444, 460
 - charges, 365–366
 - controllable items, 360
 - data, example, 714t
 - percentage, 377
- Reverse floaters, 145

- Revolving credit agreement, 88
- Rework costs, examples, 761
- RI. See Residual income
- Rigas, Timothy J., 4n
- Risk
- appetite/strategies, alignment, 230
 - control, 142, 233–234
 - definition, 228–230
 - finance, 236
 - identification, 231
 - incorporation. See Capital budgeting
 - judgment, 527
 - neutralization, 235, 236–237
 - policy, specification, 234–235
 - relationship. See Capital budgeting; Financial leverage
 - retention, 235, 236
 - transfer, 235, 237–255. See also Alternative risk transfer
- Risk-adjusted discount rate, 527
- Risk-adjusted rate, 515–518
- Risk-free interest rate, 522
- Risk-free securities, depositing, 79
- Risk management, 235–237. See also Chief Financial Officer
- CFO role, 228
 - culture, 233–234
 - futures, usage, 243
- Risk premium, 55
- Risk-response decisions, 230
- Risk/return, customization factors, 144
- ROA. See Return on assets
- Rode, David C., 540n
- ROE. See Return on equity
- ROI. See Return on investment
- Rostain, Tanina, 204n
- ROV. See Real options valuation
- RRR. See Required rate of return
- Ryan, Glenn P., 489n
- Ryan, Patricia, 489n
- Salaries, 641
- Sale-and-leaseback transactions, 543
- Sales budget, 724–725
 - information, 726
 - schedule, 725t
- Sales forecasting, 161–163
- Sales forecasts, 723
- Sales price variance, 396, 401
 - analysis, 401t
- Sales risk, 431
- Sales taxes, 218
- Sales-to-inventory ratio, 282n
- Salvage value. See Assets
- Samson, William D., 327
- Sarbanes-Oxley Act of 2002 (SOX Act), 2
 - CFO, relationship, 2–6
 - compliance, 7
 - provisions, 3t–4t
 - impact. See Chief Financial Officer
 - Section 206, 4–5
 - Section 302, 5
 - Section 304, 5
 - Section 401, 5
 - Section 401(a), 95, 560
 - Section 404, 5
 - compliance, 204
 - Section 409, 5–6
 - Section 906, 6
- Scale differences. See Capital budgeting
- Schedule 13D, 9t
- Schedule 14D-1, 9t
- Scheduled costs, 750
- Scheduled principal repayment, 66
- Schedules. See Budgeted schedules
- Scholes, Myron, 110n, 519n
- Schwert, G. William, 44n
- Scrap material, 697
 - accounting, 700–701
- Seasonal considerations, 163–165
- Secured bonds, types, 76–77
- Secured financing, 90–93
 - loan-to-value, 93
- Secured loans, 87
- Securities
 - IRS interpretation, 82n
 - law, 72
- Securities and Exchange Commission (SEC)
 - 17 CFR 228/229, 11n
 - acceptance. See Direct costing
 - annual financial statements, filing, 101
 - disclosure rules, 45n
 - financial reports, nonacceptance, 806
 - Regulation A, 72
 - Regulation D, 72
 - reporting requirements/regulations, 7
 - RIN 3235-AH82, 8n
 - Rule 144A, 72
 - security, 141
 - Rule 415, 72, 85
 - securities, registration, 63
- Securitization transaction
 - complexity, 126
 - usage, reasons, 127–136
- Segment income statement, 369

- Selective product flow, 680
 - flowchart, 681f
- Self-interest, motivation, 46–47
- Seller/servicer, quality, 135–136
- Selling budgets, 732–736
- Selling expense budgets, 732
 - example, 734t–735t
- Selling price, equation, 393
- Selling profit center, variable costs, 417
- Semivariable costs, 621
 - representation, 622f
- Semivariable costs per direct labor hour, variable component, 362
- Seneviratne, Lakmal, 630n
- Senior bank loans, 70
- Senior bond classes, 127
- Seniority. *See* Bonds
 - level, 86
- Senior-subordinate structure, 127
 - usage, 138–139
- Sensitivity analysis, 171
 - unmanageability, 505
- Separable costs, 704
- Sequential product flow, 680
 - flowchart, 681f
- Service departments, costs, 346–347, 624
- Servicer, 135
 - quality. *See* Seller/servicer
- Settlement date, 241
- SFAS. *See* Statement of Financial Accounting Standards
- Shareholders, owners, 99
- Shareholder value added (SVA), 184
- Shares, repurchase, 115
- Shelf registration rule, 72
- Shield. *See* Interest expense; Interest tax shield
- Shift premiums, payment, 644–645
- Short Cycle Manufacturing, 765n
- Short-run productive capacity, 649
- Short-term assets, 434
 - management, 579
 - conclusion, 607–608
- Short-term bank loans, 87–88
- Short-term debt, covenants, 175–176
- Short-term financing, 86–93
 - arrangements, 86
- Short-term investments, 171
 - decisions, 434
- Short-term obligations, 277
- Short-term risk-free interest rate, 519
- Shutdown costs, 629
- SIC. *See* Standard Industrial Classification
- Signaling explanation, 108, 110
- Silo structure, 230–231
- Simulation
 - analysis, 171, 505
 - demonstration, 506f
 - cash flow uncertainty, relationship, 172f
- Single-investor leases, leveraged leases (contrast), 534–535
- Single-investor lessor, 546n
- Single-investor nonleveraged leases, 546
- Single payment loan, 87
- Single plantwide overhead application rates, multiple departmental factory overhead application rates (contrast), 657
- Single trustee, duties (assumption), 550n
- Sinha, Sidharth, 46n
- Sinking fund. *See* Preferred stock
 - call price, 79
 - provision, 77, 119
 - reference, 288
 - requirement, 78–79
- Six Sigma, 11t
- Slippage, 675
- Smith, Bill, 11n
- Social Security, contribution, 643
- SOX Act. *See* Sarbanes-Oxley Act of 2002
- Special-purpose entity (SPE), 93
 - asset pool, linking, 124
 - consolidation, 94
 - establishment, 559
 - legal entity, setup, 126
- Specification costs, 750
- Speculative balance, 583
- Spending variance, 784–785
- Spitzer, Eliot (investigation), 254
- Split-off point, 704. *See also* Joint costs
- Spoiled units, 697
 - accounting, 698–699
- Spreadsheet program, usage, 468n
- Stand-alone risk, 499–500
 - gauging, 500
- Standard absorption costs, 682
- Standard costing, 50, 749
 - conclusion, 788–790
- Standard costs, 626–627
 - definition, 719
 - determination, 757–758, 787
 - uses, 751–752
- Standard deviation. *See* Outcomes
 - calculation, 503t
 - relationship. *See* Project risk

- Standard Industrial Classification (SIC)
system, 303
- Standard & Poor's (S&P), 134–136
- Standard product cost, determination, 758
- Standards
establishment, 753–764. See also Job
order; Process cost system
example, 770t
types, 752–753
- Statement of Financial Accounting Standards
(SFAS)
No. 109, 208
No. 140, 129n
No. 143, 302n
No. 156, 129n
- State taxes, 218
- State unemployment insurance (SUI), 643
- Static budgets, 758
example, 760t
- Static NPV, 519
- Step costs, 621–622
representation, 623f
- Stewart III, G. Bennet, 184n
- Stickney, C.P., 326n
- Stock. See Common stock; Preferred stock
distribution, 104–106
dividend
motivation, 106
requirement, 105n
dual classes, 102
repurchase, 114
shares, issuance, 29
splits, motivation, 106
- Stockholders, owners, 99
- Stockless Production, 765n
- Storage time, 767
reduction, 769
- Strategic NPV, 519
- Strategic plan, 154
action, 187
- Strategic planning, 722–723. See also Chief
Financial Officer
- Strategic risk management, 233
- Strategy
budgeting, relationship, 155f
definition, 153
value
addition, 157–158
creation, relationship, 191–194
relationship, 155–158
- Strategy planning, 153
conclusion, 195
- Stress testing, 234
- Strike price, 244, 520
- Structured finance, 237
- Structured financing, 123
conclusion, 149–150
flowchart, 126f
- Structured notes, 86, 123
conclusion, 149–150
creation, 143–144
examples, 144–149
fixed income debentures, 140–141
rule busters, 142
usage, 139–149
- Stuart, Alix Nyberg, 600n
- Suboptimal decision making, 406
- Subordinate bond classes, 127
- Subordinated bond, 77
- Substitutes, threat, 194
- SUI. See State unemployment insurance
- Summation notation, usage, 467
- Sunk cost, 438, 626
- Supervisors
report, 334
responsibility level, 331
- SVA. See Shareholder value added
- Swaps, 246–248
OTC instrument, 246
payments, 147
- Syndicated bank loans, 69–71
- Synthetic leases, 558–560
development, 559
- Synthetic market price, 417–418
- System flow, 679–680
- Takeover defenses, 45
definition, 46
- Targeted block repurchase, 112–113
- Taub, Stephen, 8n, 45n, 536n, 600n
- Taxable income
determination, 222–223
insufficiency, 35–36
- Tax authorities, concern, 420
- Tax deductions
credits, relationship, 48
impact, 217t
tax credits, contrast, 216
- Tax director, heading, 198
- Taxes
basis, 439, 455–456. See also Building;
Equipment
bracket, base, 205
change, 445–446
credits, 216

- Taxes (*Cont.*)
 relationship. See Tax deductions
 usage, 562n
 function, expectations (increase), 201f
 havens, 219
 impact, 498
 incentives, 52
 indemnities, 554, 555
 law, changes (indemnification), 570–571
 management, 199–200
 rate. See Flat tax rate
- Tax leases, 557n
- Tax-oriented leases
 transactions, 558
 usage, 537
- Tax-oriented true leases, 533–534
 IRC distinctions. See Nontax-oriented leases
- Tax-preference explanation, 107, 109–110
- Tax-related cash outflow (reduction), depreciation (impact). See Company
- Tax Relief and Health Care Act of 2006, 109n
- Tax risk, 200–205
 general risk areas, 201
 specific risk areas, 201
 types, 202t
- Tax risk management
 basics, 197
 conclusion, 224–225
- Tax shield. See Interest tax shield; Unused tax shield
 equation, 34–35
- TCO. See Total cost ownership
- Teach, Edward, 525n
- Technological innovations, impact, 388
- Telpner, Joel S., 140n
- 10-K report, 9t
- 10-Q report, 9t
- Tender offer, 112
- Tergesen, Anne, 143n
- Terminal value, 478
- Term loans, 65–69
 amortization schedule, 66t–67t
 floating rate, 68t–69t
- Term to maturity, 74. See Bonds
- Thailand, Revenue Department (impact), 422–423
- Theoretical productive capacity, 649
- Therrien, Lois, 156n
- Thin capitalization rules, 59n
- Third-party guarantees, 137
- Three-factor analysis. See Factory overhead
- Three-party transactions, 535, 547
- Throughput time, 766
 calculation, 767
- Tier 1 capital, 82
- Time-and-motion studies, 756, 758
- Time-based competition, 765n
- Time card, usage, 642
- Timekeeping. See Labor
 records, accumulation, 655
- Times interest-covered ratio, 287
- Time value. See Money
- Title VII, studies/reports, 4t
- Titman, Sheridan, 106n
- Total administration expenses, 366
- Total assets turnover, 283–284
- Total capital expenditures, 317
- Total contingent lease payments, 545
- Total contribution margin, equality. See Total fixed expenses
- Total cost ownership (TCO), concept, 494
- Total debt-to-assets ratio, 285
- Total dollars, calculation, 599
- Total factory overhead, 648
- Total fixed expenses, total contribution margin (equality), 804
- Total fixed warehouse costs, 618
- Total payroll, computation. See Labor
- Total quality control (TQC), 604
- Total return swaps, 250
- Total risk, 499–500
 evaluation tools, 504–505
- Total selling expenses, 366
- Total variable direct material cost, pattern, 617f
- TQC. See Total quality control
- Trade credit, 87, 591–592
 insurance, 238
- Trade-off analysis. See Capital structure completion, absence, 51
- Trade-off theory, 49–50
- Traditional costing, ABC (contrast), 663t
- Traditional insurance, 237–239
- Transactional net margin method, 421
- Transactional profits methods, 421
- Transactional risk, 201, 203
- Transactions balance, 582
- Transactions level, increase, 447
- Transfer prices, 405. See also Cost-plus transfer price
 post-tax profit, 419t, 420t
 relationship. See Intercompany transactions

- Transfer prices (*Cont.*)
 setting, 413
 signal, 405–406
 usage, 406–407
- Transfer pricing, 405. See also International transfer pricing
 conclusion, 424–425
 cost, 410–411
 criteria, interrelationship, 407–408
 diagram, 409f, 416f
 example, 408–418
 data, 409t
 importance, 406
 methods, 407–418
 system. See Dual transfer pricing system
- Trigeogis, Lenos, 525n
- Triple-net lease, 532
- Troubh, Raymond S., 2n
- True lease
 comparison. See Leveraged lease
 cost, 537
 IRS discouragement, 540
 qualification. See Lease transactions, federal income tax requirements, 556–558
- Trustee bonds, delivery, 79
- Trust-preferred securities, 82
- Trust receipts loan, 92
- Turnover ratio, 263
 down trend, 326
- Two-factor analysis. See Factory overhead
- Tyco, scandals, 227
- Unallocated fixed expenses, 369
- Uncertainty
 concept, 464
 degree, 582
- Underapplied factory overhead, analysis, 659–660
- Underlying asset, value, 519
 equation, example, 529
- Underwriter, 73
- Underwriting, 73. See also Competitive bidding underwriting standards, 125
- Unequal lives. See Capital budgeting
- Unfunded retained risk, 236
- Unitized fixed costs, 618
 misuse, potential, 619
- Units. See Defective units; Spoiled units
 abnormal spoilage, 699
 increase, 692–693
 level, stabilization, 692
 normal spoilage, 698
 production, estimation, 648
- Unsecured financing, 87–90
- Unused tax shield, 35–37
- Upper-level management
 accountability, 783
 expectations, 383
 investment, proposal, 382
 variance investigative procedures, usage, 355
- Upper-level managers, planning (attention), 337
- Upper management approach, 723
- U.S. Code Title 11, 39
- U.S. companies, revenues, 164f
- U.S.-dollar-denominated bonds, payoff (linkage), 142n
- U.S. drug industry (2005), 293f–294f
- U.S. Foreign Corrupt Practices Act (FCPA), compliance, 7
- U.S. GAAP, convergence, 302
- U.S. tax law, 205–218
- Vacation pay, charge, 644
- Value creation
 relationship. See Strategy sources, 192–194
- Value Line, Inc., cash flow estimate, 310n
- Variable costs, 23f
 decrease, 362
 relevance, 412
 usage, 616–617
- Variable expenses, deduction, 796
- Variable factory overhead
 application rates, 657
 costs, 647
- Variable interest entities, 94
 consolidation, 94
- Variance. See Efficiency variance; Mix variance; Price; Production volume variance; Pure volume variance
 analysis, 769–786
 disposition, 786–788
 method, 787–788
 summary, 404t
- Variation margin, 242–243
- Veasey, Norman, 228
- Vendors
 invoice, flowchart, 638f
 quality standards, 763
- Vice presidents
 level 3, 342
 manufacturing, level 3, 343, 345
 responsibility level, 331

- Volume, costs (relationship), 616–622
- Volume variance, 396. See also Pure volume variance
analysis, 402t
- Voting rights. See Contingent voting rights; Preferred stock
- Vouchers, usage, 658
- WACC. See Weighted-average cost of capital
- Wages, 641. See also Guaranteed wages
cash outflows, 168
- Waiting time, 767
reduction, 768
- Wal-Mart Stores, Inc.
cash flows (1990-2005), 316f
revenues/operating profile/net income, 315f
- Walt Disney Co.
10-K filing (2005), 216n
MTNs, issuance, 85–86
segment revenues/operating income, 304f
zero-coupon subordinated notes
implied interest, 76t
maturity, 75
- Ward, Terry (study), 327
- Waste material, presence. See Job order; Process costing
- Waste time reduction, strategies, 768–769
- Weighted average costing, 693z
FIFO costing, comparison, 694t
- Weighted-average cost of capital (WACC), 511–512
change, 512n
- Weighted average purchase price, computation, 772t
- White-collar crime penalty enhancements, 4t
- Winokur, Jr., Herbert S., 2n
- Working capital, 430
changes, 447–449, 457
classification, 449
concept, 311
conservation, 537–538
definition, 579
- Work-in-process, 601
inventories, initiation, 693
inventory accounts. See Departmental work-in-process inventory accounts
transfer, 669
- WorldCom, scandals, 227
- W.T. Grant, bankruptcy, 327
- Year-end adjusting entries, usage, 658
- Yield calculation, 76
- Yoon, Lisa, 102
- Zero-balance account (ZBA), 588
- Zero-based budget (ZBB) system, 722
- Zero-coupon bond, potential, 146
- Zero defects program, 762
- Zero inventory production system (ZIPS), 680