

TOSHITSUNE MIYAKE

Modular Forms



 Springer

Springer Monographs in Mathematics

Springer Monographs in Mathematics

Toshitsune Miyake

Modular Forms

With 11 Figures

 Springer

Toshitsune Miyake
Hokkaido University
Department of Mathematics
060-0810 Sapporo, Japan
e-mail: miyake@math.sci.hokudai.ac.jp

Translator

Yoshitaka Maeda
Hokkaido University
Department of Mathematics
060-0810 Sapporo, Japan
e-mail: maeda@math.sci.hokudai.ac.jp

The first English edition was published as a monograph in 1989 by Springer-Verlag (ISBN 3-540-50268-8).

Title of the original Japanese edition: "Hokei keishiki to seisūron"

© Kinokuniya Company Ltd., Tokyo, 1976.

Library of Congress Control Number: 2005936235

Mathematics Subject Classification (2000): 11F03, 11F06, 11F11, 11F12, 11F27, 11F30, 11F66, 11G05, 11M06, 11R42, 11R52, 11R56

ISSN 1439-7382

ISBN-10 3-540-29592-5 Springer Berlin Heidelberg New York

ISBN-13 978-3-540-29592-1 Springer Berlin Heidelberg New York

This work is subject to copyright. All rights are reserved, whether the whole or part of the material is concerned, specifically the rights of translation, reprinting, reuse of illustrations, recitation, broadcasting, reproduction on microfilm or in any other way, and storage in data banks. Duplication of this publication or parts thereof is permitted only under the provisions of the German Copyright Law of September 9, 1965, in its current version, and permission for use must always be obtained from Springer. Violations are liable for prosecution under the German Copyright Law.

Springer is a part of Springer Science+Business Media

springeronline.com

© Springer-Verlag Berlin Heidelberg 1989, 2006

Printed in Germany

The use of general descriptive names, registered names, trademarks, etc. in this publication does not imply, even in the absence of a specific statement, that such names are exempt from the relevant protective laws and regulations and therefore free for general use.

Typesetting: Macmillan India Ltd., Bangalore

Production: LE-TeX Jelonek, Schmidt & Vöckler GbR, Leipzig

Cover design: Erich Kirchner, Heidelberg

Printed on acid-free paper

46/3142YL - 5 4 3 2 1 0

Preface

Modular forms play an essential role in Number Theory. Furthermore the importance of modular forms has continued to grow in many areas of mathematics including the infinite dimensional representation theory of Lie groups and finite group theory. The aim of this book is to introduce some basic theory of modular forms of one variable.

Originally this book was written in Japanese under the title “Automorphic forms and Number Theory” by Koji Doi and myself and published by Kinokuniya, Tokyo, in 1976. When the English translation was planned, the first named author proposed that only the chapters written mainly by me be translated together with some additional material and published under my sole authorship.

In Chapters 1 and 2, the general theory of Fuchsian groups, automorphic forms and Hecke algebras is discussed. In Chapter 3, I summarize some basic results on Dirichlet series which are necessary in the succeeding chapters. In Chapter 4, the classical theories of modular groups and modular forms are studied. Here the usefulness of Hecke operators as well as the remarkable relation between modular forms and Dirichlet series obtained by Hecke and Weil have been emphasized. Chapter 5 briefly reviews quaternion algebras and their unit groups, which are also Fuchsian groups and which play a role similar to that of modular groups in their application to number theory. Chapter 6 is devoted to the trace formulae of Hecke operators by Eichler and Selberg. The formulae have been generalized by many people including H. Shimizu, H. Hijikata and H. Saito. A formula computable by them is also offered. In our Japanese edition, as an introduction to the automorphic forms of several variables, Chapter 7 deals with Eisenstein series of Hilbert modular groups and the application to values of zeta-functions (following Siegel). As a result of important series of recent work by Shimura on Eisenstein series, I decided to rewrite it to introduce some of his results on Eisenstein series restricting it to only the case of one variable.

I should like to express my deepest gratitude to Professor Goro Shimura, who constructed the essential part of the arithmetic theory of automorphic functions, for his valuable suggestions and encouragement.

The translation of Chapters 1 through 6 was prepared by my colleague Professor Yoshitaka Maeda. He also corrected mistakes in the original text, and gave me many appropriate suggestions. I express my deep and sincere thanks to him for his collaboration. I also express my hearty thanks to Professor Haruzo Hida

whose lectures at Hokkaido University during 1983–84 were very helpful for the preparation of the present volume, and to Professor Hiroshi Saito and Dr. Masaru Ueda who kindly read the manuscript very carefully as a whole or in part and made many valuable suggestions.

Sapporo, February 1989

Toshitsune Miyake

Contents

Notation and Terminology	IX
Chapter 1. The Upper Half Plane and Fuchsian Groups	1
§1.1. The Group of Automorphisms of the Upper Half Plane	1
§1.2. Actions of Groups	4
§1.3. Classification of Linear Fractional Transformations	7
§1.4. The Invariant Metric and Measure on \mathbf{H}	10
§1.5. Fuchsian Groups	17
§1.6. Fundamental Domains	20
§1.7. Quotient Spaces $\Gamma \backslash \mathbf{H}^*$	24
§1.8. The Structure of $\Gamma \backslash \mathbf{H}^*$ as a Riemann Surface	28
§1.9. Fuchsian Groups of the First Kind	31
Chapter 2. Automorphic Forms	37
§2.1. Automorphic Forms	37
§2.2. Differentials on Compact Riemann Surfaces	45
§2.3. Automorphic Forms and Differentials	48
§2.4. The Measure of $\Gamma \backslash \mathbf{H}^*$	53
§2.5. Dimensions of $\mathcal{S}_k(\Gamma)$ and $\mathcal{L}_k(\Gamma)$	57
§2.6. Poincaré Series and Eisenstein Series	61
§2.7. Hecke Algebras	69
§2.8. Hecke Operators on the Space of Automorphic Forms	74
Chapter 3. L-Functions	79
§3.1. Dirichlet Characters	79
§3.2. The Riemann Zeta-Function	84
§3.3. Hecke L -Functions	90
Chapter 4. Modular Groups and Modular Forms	96
§4.1. $SL_2(\mathbb{Z})$	96
§4.2. Congruence Modular Groups	103
§4.3. Modular Forms and Dirichlet Series	114

§4.4. $\Delta(z)$ and $\eta(z)$	129
§4.5. Hecke Algebras of Modular Groups	131
§4.6. Primitive Forms	153
§4.7. Dirichlet L -Functions and Modular Forms	175
§4.8. L -Functions of Quadratic Fields and Cusp Forms	182
§4.9. Theta Functions	185
Chapter 5. Unit Groups of Quaternion Algebras	195
§5.1. Algebras over \mathbb{Q} and Adelization	195
§5.2. Quaternion Algebras	198
§5.3. Hecke Algebras of Unit Groups of Quaternion Algebras	210
Chapter 6. Traces of Hecke Operators	219
§6.1. Spaces of Functions on \mathbf{H}	219
§6.2. The Projection of $L_k^p(\mathbf{H})$ onto $H_k^p(\mathbf{H})$	225
§6.3. Function Spaces Consisting of Automorphic Forms	228
§6.4. Traces of Hecke Operators (Calculation of Integrals)	231
§6.5. Traces of Hecke Operators (Algebraic Calculation)	243
§6.6. Local Conjugacy Classes	248
§6.7. Class Numbers of Orders of $\mathbb{Q}[\alpha]$	256
§6.8. An Explicit Formula for $\text{tr}(T(n))$	259
Chapter 7. Eisenstein Series	268
§7.1. Eisenstein Series of Weight $k \geq 3$	268
§7.2. Analytic Continuation of Eisenstein Series	274
Numerical Tables	295
References	315
List of Symbols	317
Subject Index	333

Notation and Terminology

1. We denote by \mathbb{Z} , \mathbb{Q} , \mathbb{R} and \mathbb{C} , the ring of rational integers, the rational number field, the real number field and the complex number field, respectively. For a rational prime p , \mathbb{Z}_p and \mathbb{Q}_p denote the ring of p -adic integers and the field of p -adic numbers, respectively. We also denote by \mathbb{R}_+ , \mathbb{R}_- and \mathbb{C}^1 , the set of positive real numbers, the set of negative real numbers and the set of complex numbers with absolute value 1, respectively:

$$\mathbb{R}_+ = \{x \in \mathbb{R} \mid x > 0\}, \mathbb{R}_- = \{x \in \mathbb{R} \mid x < 0\}, \mathbb{C}^1 = \{z \in \mathbb{C} \mid |z| = 1\}.$$

2. For a complex number z , we denote by $\operatorname{Re}(z)$ and $\operatorname{Im}(z)$, the real part and the imaginary part of z , respectively. When z is a non-zero complex number, we denote by $\arg(z)$ the argument of z , which we specify by $-\pi < \arg(z) \leq \pi$. For a real number x , we denote by $[x]$ the largest integer not exceeding x . When x is a non-zero real number, $\operatorname{sgn}(x)$ denotes $+1$ or -1 according as $x > 0$ or $x < 0$.

3. For a ring R with unity 1, we denote by R^\times the group of invertible elements in R . Further we write

$M_n(R)$ = the set of square matrices of degree n over R ,

$$GL_n(R) = \{\alpha \in M_n(R) \mid \det(\alpha) \in R^\times\},$$

$$SL_n(R) = \{\alpha \in M_n(R) \mid \det(\alpha) = 1\}.$$

4. We denote by \amalg the disjoint union of sets. For a finite set A , $|A|$ denotes the number of elements in A . We also denote by $\# \{ \dots \}$, the number of the elements of the set given by $\{ \dots \}$.

5. When g_1, \dots, g_m are elements of a group G , $\langle g_1, \dots, g_m \rangle$ denotes the subgroup of G generated by g_1, \dots, g_m . When v_1, \dots, v_m are vectors in a vector space V over a field K , $\langle v_1, \dots, v_m \rangle$ denotes the subspace of V generated by v_1, \dots, v_m . For mappings $g: A \rightarrow B$ and $f: B \rightarrow C$, we denote by $f \circ g$ the mapping of A to C given by

$$(f \circ g)(a) = f(g(a)) \quad (a \in A).$$

Chapter 1. The Upper Half Plane and Fuchsian Groups

We explain basic properties of the upper half plane \mathbf{H} in § 1.1 through § 1.4. We introduce Fuchsian groups in § 1.5 which play an essential role throughout the book. In § 1.6 through § 1.8, we study the quotient spaces of \mathbf{H} by Fuchsian groups and induce the structure of Riemann surfaces on them.

§ 1.1. The Group of Automorphisms of the Upper Half Plane

We denote by \mathbb{P} the Riemann sphere $\mathbb{C} \cup \{\infty\}$ and define the action of an element

$\alpha = \begin{bmatrix} a & b \\ c & d \end{bmatrix}$ of $GL_2(\mathbb{C})$ on \mathbb{P} by

$$(1.1.1) \quad \alpha z = \frac{az + b}{cz + d} \quad (z \in \mathbb{P}).$$

This mapping “ $z \mapsto \alpha z$ ” is complex analytic from \mathbb{P} into itself. We put

$$(1.1.2) \quad j(\alpha, z) = cz + d \quad (z \in \mathbb{C}).$$

If $z \in \mathbb{C}$ and $j(\alpha, z) \neq 0$, then we have

$$(1.1.3) \quad \alpha \begin{bmatrix} z \\ 1 \end{bmatrix} = \begin{bmatrix} az + b \\ cz + d \end{bmatrix} = j(\alpha, z) \begin{bmatrix} \alpha z \\ 1 \end{bmatrix}.$$

This equality also holds when considering each constituent as a meromorphic function. Calculating $\alpha\beta \begin{bmatrix} z \\ 1 \end{bmatrix}$ ($\alpha, \beta \in GL_2(\mathbb{C})$) in two ways, we see that

$$j(\alpha, \beta z) j(\beta, z) \begin{bmatrix} \alpha(\beta z) \\ 1 \end{bmatrix} = j(\alpha\beta, z) \begin{bmatrix} (\alpha\beta)z \\ 1 \end{bmatrix}.$$

From this equality, we obtain

$$(1.1.4) \quad (\alpha\beta)z = \alpha(\beta z) \quad (\alpha, \beta \in GL_2(\mathbb{C}), z \in \mathbb{P}),$$

and

$$(1.1.5) \quad j(\alpha\beta, z) = j(\alpha, \beta z) j(\beta, z) \quad (\alpha, \beta \in GL_2(\mathbb{C}), z \in \mathbb{C}).$$

By (1.1.4), the mapping “ $z \mapsto \alpha^{-1}z$ ” is the inverse mapping of “ $z \mapsto \alpha z$ ”, and therefore, “ $z \mapsto \alpha z$ ” is an automorphism of the Riemann sphere \mathbb{P} . This automorphism is called a *linear fractional transformation*. Putting $\beta = \alpha^{-1}$ in (1.1.5), we see

$$(1.1.6) \quad j(\alpha^{-1}, z) = j(\alpha, \alpha^{-1}z)^{-1}.$$

Lemma 1.1.1. *A linear fractional transformation maps circles and lines on \mathbb{C} into circles or lines on \mathbb{C} .*

Proof. We put for an element $\beta = \begin{bmatrix} a & b \\ c & d \end{bmatrix}$ of $GL_2(\mathbb{C})$

$$C_\beta = \{z \in \mathbb{P} \mid |\beta z| = 1\}.$$

Since z belongs to $C_\beta \cap \mathbb{C}$ if and only if $|az + b| = |cz + d|$, $C_\beta \cap \mathbb{C}$ is a line (if $a = c$) or a circle (the Apollonius circle). Conversely it is easily seen that circles and lines on \mathbb{C} can be expressed as $C_\beta \cap \mathbb{C}$ with some $\beta \in GL_2(\mathbb{C})$. Let α be an element of $GL_2(\mathbb{C})$ and denote by $\alpha(C_\beta)$ the image of C_β by α . Since $\alpha(C_\beta) = C_{\beta\alpha^{-1}}$, $\alpha(C_\beta) \cap \mathbb{C}$ is again a circle or a line on \mathbb{C} . \square

We define two domains \mathbf{H} and \mathbf{K} of \mathbb{C} by

$$\mathbf{H} = \{z \in \mathbb{C} \mid \text{Im}(z) > 0\}$$

and

$$\mathbf{K} = \{z \in \mathbb{C} \mid |z| < 1\}.$$

The domains \mathbf{H} and \mathbf{K} are called the *upper half plane* and the *unit disk*, respectively.

Lemma 1.1.2. *The upper half plane \mathbf{H} and the unit disk \mathbf{K} are complex analytically isomorphic.*

Proof. Put $\rho = \begin{bmatrix} 1 & -i \\ 1 & i \end{bmatrix}$. Then “ $z \mapsto \rho z$ ” is an automorphism of \mathbb{P} , and satisfies

$$|\rho z| = \left| \frac{z-i}{z+i} \right| < 1 \quad (z \in \mathbf{H}).$$

Since we see

$$\text{Im}(\rho^{-1}w) = \text{Im}\left(i \frac{w+1}{-w+1}\right) = \frac{1-|w|^2}{|1-w|^2} > 0 \quad (w \in \mathbf{K}),$$

ρ gives an analytic isomorphism of \mathbf{H} onto \mathbf{K} . \square

We are interested in functions on \mathbf{H} which satisfy certain transformation equations for automorphisms of \mathbf{H} . (We say that *they have automorphy*.) We first study automorphisms of \mathbf{H} . We denote by $\text{Aut}(\mathbf{H})$ and $\text{Aut}(\mathbf{K})$ the groups of all (complex analytic) automorphisms of \mathbf{H} and \mathbf{K} , respectively. If $\alpha = \begin{bmatrix} a & b \\ c & d \end{bmatrix} \in GL_2(\mathbb{R})$,

and $z \in \mathbf{H}$, then

$$(1.1.7) \quad \operatorname{Im}(\alpha z) = \frac{\det(\alpha) \operatorname{Im}(z)}{|cz + d|^2}.$$

In particular, if $\det(\alpha) > 0$, then we have $\operatorname{Im}(\alpha z) > 0$, and therefore, “ $z \mapsto \alpha z$ ” induces an automorphism of \mathbf{H} . We put

$$GL_2^+(\mathbb{R}) = \{\alpha \in GL_2(\mathbb{R}) \mid \det(\alpha) > 0\},$$

and denote by $\iota(\alpha)$ ($\alpha \in GL_2^+(\mathbb{R})$) the automorphism “ $z \mapsto \alpha z$ ” of \mathbf{H} . Then it follows from (1.1.4) that this mapping

$$\iota: GL_2^+(\mathbb{R}) \ni \alpha \mapsto \iota(\alpha) \in \operatorname{Aut}(\mathbf{H})$$

is a group-homomorphism.

Now we put

$$SO_2(\mathbb{R}) = \left\{ \begin{bmatrix} \cos \theta & \sin \theta \\ -\sin \theta & \cos \theta \end{bmatrix} \mid 0 \leq \theta < 2\pi \right\}.$$

We identify $a \in \mathbb{R}^\times$ with $\begin{bmatrix} a & 0 \\ 0 & a \end{bmatrix} \in GL_2^+(\mathbb{R})$. If for $\alpha = \begin{bmatrix} a & b \\ c & d \end{bmatrix} \in GL_2(\mathbb{R})$, $\iota(\alpha)$ is the identity of \mathbf{H} , then α belongs to \mathbb{R}^\times , since $cz^2 + (d-a)z - b = 0$ for any $z \in \mathbf{H}$. Now we have

Theorem 1.1.3. (1) For any $z \in \mathbf{H}$, there exists an element α in $SL_2(\mathbb{R})$ satisfying $\alpha i = z$.

(2) The homomorphism ι induces an isomorphism

$$GL_2^+(\mathbb{R})/\mathbb{R}^\times \simeq SL_2(\mathbb{R})/\{\pm 1\} \simeq \operatorname{Aut}(\mathbf{H}).$$

(3) $SO_2(\mathbb{R}) = \{\alpha \in SL_2(\mathbb{R}) \mid \alpha i = i\}$

and

$$\mathbb{R}^\times \cdot SO_2(\mathbb{R}) = \{\alpha \in GL_2^+(\mathbb{R}) \mid \alpha i = i\}.$$

Proof. For any $z = x + yi \in \mathbf{H}$, put $\alpha = \sqrt{y}^{-1} \begin{bmatrix} y & x \\ 0 & 1 \end{bmatrix}$. Then α belongs to $SL_2(\mathbb{R})$ and $\alpha i = z$; this proves (1). The first isomorphism of (2) is obvious. To see the second isomorphism, we have only to verify the surjectivity. For this purpose, it is sufficient to show that if an element ψ of $\operatorname{Aut}(\mathbf{H})$ satisfies $\psi(i) = i$, then there exists an element β in $SO_2(\mathbb{R})$ such that $\psi = \iota(\beta)$. In fact, for each element $\phi \in \operatorname{Aut}(\mathbf{H})$, we get an element $\alpha \in SL_2(\mathbb{R})$ satisfying $\alpha^{-1}\phi(i) = i$ by (1). Then taking $\iota(\alpha^{-1})\phi$ in place of ψ , we have $\phi = \iota(\alpha\beta)$ for some $\beta \in SO_2(\mathbb{R})$; this implies ι is surjective. Now let ψ be an element of $\operatorname{Aut}(\mathbf{H})$ such that $\psi(i) = i$. We put

$$\rho(z) = (z - i)/(z + i) \quad (z \in \mathbf{H}),$$

which is an isomorphism of \mathbf{H} onto \mathbf{K} . Since $\rho(i) = 0$, $\eta = \rho\psi\rho^{-1}$ is an automorphism of \mathbf{K} such that $\eta(0) = 0$. Applying Schwarz's theorem to η and η^{-1} , we see that

$$|\eta(w)| = |w| \quad (w \in \mathbf{K}).$$

A further application of Schwarz's theorem shows that there exists $\theta(0 \leq \theta < \pi)$ such that

$$\eta(w) = e^{2\theta i} w \quad (w \in \mathbf{K}).$$

Thus pulling back the function η by ρ^{-1} to \mathbf{H} , we see that

$$\psi(z) = \rho^{-1} \eta \rho(z) = \frac{(\cos \theta)z + \sin \theta}{(-\sin \theta)z + \cos \theta} \quad (z \in \mathbf{H});$$

namely $\psi = {}_t(k_\theta)$ with $k_\theta = \begin{bmatrix} \cos \theta & \sin \theta \\ -\sin \theta & \cos \theta \end{bmatrix} \in SO_2(\mathbb{R})$. This implies (2) and (3). \square

Now let us consider $\text{Aut}(\mathbf{K})$. Put

$$\begin{aligned} SU(1, 1) &= \left\{ g \in SL_2(\mathbb{C}) \mid {}^t \bar{g} \begin{bmatrix} 1 & 0 \\ 0 & -1 \end{bmatrix} g = \begin{bmatrix} 1 & 0 \\ 0 & -1 \end{bmatrix} \right\} \\ &= \left\{ g = \begin{bmatrix} u & v \\ \bar{v} & \bar{u} \end{bmatrix} \mid u, v \in \mathbb{C}, |u|^2 - |v|^2 = 1 \right\}. \end{aligned}$$

Since

$$(1.1.8) \quad \rho SL_2(\mathbb{R}) \rho^{-1} = SU(1, 1), \quad \rho = \begin{bmatrix} 1 & -i \\ 1 & i \end{bmatrix},$$

we see by Lemma 1.1.2 and Theorem 1.1.3(2)

$$(1.1.9) \quad \text{Aut}(\mathbf{K}) \simeq SU(1, 1) / \{\pm 1\}.$$

§ 1.2. Actions of Groups

In this section, we prepare general theory on topological spaces and transformation groups to apply it to the upper half plane \mathbf{H} .

Let G be a group and X a topological space (resp. a complex domain). We say that G acts on X if there exists a mapping

$$G \times X \ni (g, x) \mapsto gx \in X$$

satisfying the following three conditions:

- (i) for each element g of G , " $X \ni x \mapsto gx \in X$ " is a continuous (resp. complex analytic) mapping;
- (ii) $(gh)x = g(hx)$ for two elements g and h of G ;
- (iii) for the unit element 1 of G , $1x = x$ for any element x of X .

Since for any element g of G , " $x \mapsto g^{-1}x$ " is the inverse mapping of " $x \mapsto gx$ ", we see that if G acts on X , then

- (i') for each element g of G , " $X \ni x \mapsto gx \in X$ " is a topological (resp. complex analytic) automorphism of X .

We assume hereafter that G acts on X . For an element x of X we put

$$G_x = \{g \in G \mid gx = x\},$$

and call it the *stabilizer of x* . It is obvious that for any element g of G ,

$$(1.2.1) \quad G_{gx} = gG_xg^{-1}.$$

An element x of X is called a *fixed point of $g \in G$* if

$$gx = x.$$

This is equivalent to saying $g \in G_x$. Further for each element x of X , a subset of X defined by

$$Gx = \{gx \mid g \in G\}$$

is called the *G -orbit of x* . The set of all G -orbits in X is denoted by $G \backslash X$. Since either $Gx = Gy$ or $Gx \cap Gy = \emptyset$ for any two elements x, y of X , X can be expressed as a disjoint union of G -orbits:

$$X = \coprod Gx.$$

In particular, if X itself is a G -orbit, then we say that G acts *transitively on X* . This is equivalent to saying that

(1.2.2) for any two elements x, y of X , there exists an element g of G such that $gx = y$.

Therefore, it follows from (1.2.1) that if G acts transitively on X , then all the stabilizers are conjugate.

Now let us denote by π the canonical mapping of X onto the set of all G -orbits $G \backslash X$; in other words, π is a mapping which corresponds any element x of X to the element Gx of $G \backslash X$:

$$X \ni x \mapsto \pi(x) = Gx \in G \backslash X.$$

We induce the strongest topology on $G \backslash X$ under which the above projection π is continuous. More precisely, it is given by defining that a subset U of $G \backslash X$ is open if and only if the inverse image $\pi^{-1}(U)$ of U by π is open in X . The topological space $G \backslash X$ with this topology is called the *quotient space of X by G* . Since for an open subset U of X , we have

$$\pi^{-1}(\pi(U)) = \bigcup_{g \in G} gU \quad gU = \{gu \mid u \in U\},$$

$\pi(U)$ is again open in $G \backslash X$. Thus π is an open continuous mapping of X onto the quotient space $G \backslash X$.

If a group G has a topological structure of a Hausdorff space, and the two mappings

$$G \times G \ni (g, h) \mapsto gh \in G, \quad G \ni g \mapsto g^{-1} \in G$$

are continuous with respect to its topology, then G is called a *topological group*. Let

G be a topological group and assume that G acts on X . Then we say that a topological group G acts on a topological space X , if the additional condition (iv) below is satisfied:

$$(iv) \quad G \times X \ni (g, x) \mapsto gx \in X \text{ is continuous.}$$

If a topological group G acts on a topological space X , then all the stabilizers are closed subgroups of G . Conversely, let G be a topological group and K a closed subgroup of G . Then K acts on G by right multiplication. We denote by G/K the quotient space of G by K , and call it the *space of the right cosets of G by K* .

Theorem 1.2.1. *Assume that a topological group G acts transitively on a topological space X . If G is a locally compact group with a countable basis, and X is a locally compact Hausdorff space, then for each element $x \in X$, the space of the right cosets G/G_x is homeomorphic to X by the correspondence “ $gG_x \mapsto gx$ ”.*

Proof. It is obvious that the correspondence is bijective. Thus it is sufficient to show that it is bicontinuous. From the definition of the topology on G/G_x , it is equivalent to saying that “ $g \mapsto gx$ ” is an open continuous mapping of G to X . The continuity is obvious by definition, and therefore it is sufficient to show that this mapping is also open. Let us prove that for any open set U of G , $Ux = \{gx \mid g \in U\}$ is also open in X . Let gx ($g \in U$) be any point of Ux . Take a compact neighborhood V of the unit element of G so that $V^{-1} = V$ and $gV^2 \subset U$. Since G has a countable basis, there exist countably many elements g_n ($n = 1, 2, \dots$) satisfying $G = \bigcup_{n=1}^{\infty} g_n V$. Put $W_n = g_n Vx$, then $X = \bigcup_{n=1}^{\infty} W_n$. Since W_n is a compact set in the Hausdorff space X , it is closed. Now suppose that no W_n contains an open subset. Since X is regular, we find inductively non-empty open subsets U_n so that the closures \bar{U}_n are compact and

$$U_{n-1} - W_{n-1} \supset \bar{U}_n \quad (n \geq 2).$$

Then we see that $\bar{U}_1 \supset \bar{U}_2 \supset \bar{U}_3 \supset \dots$. Since $\bigcap_{n=1}^{\infty} \bar{U}_n \neq \emptyset$ and $\bigcap_{n=1}^{\infty} \bar{U}_n$ has no common point with any W_n , this contradicts the fact $X = \bigcup_{n=1}^{\infty} W_n$. Hence there exists a set $W_m = g_m Vx$ which contains an open subset of X . Since $g_m Vx$ is homeomorphic to Vx , Vx also contains an open subset S . For an element h of V such that $hx \in S$, we have

$$gx \in gh^{-1}S \subset gV^2x \subset Ux.$$

Therefore gx is an interior point of Ux . This proves that Ux is open. \square

Now Theorem 1.1.3 implies that the topological group $SL_2(\mathbb{R})$ acts transitively on the complex domain \mathbf{H} and the stabilizer of i is $SO_2(\mathbb{R})$. Thus, applying the above theorem to $X = \mathbf{H}$ and $G = SL_2(\mathbb{R})$, we obtain the following

Corollary 1.2.2. *The space of the cosets $SL_2(\mathbb{R})/SO_2(\mathbb{R})$ is homeomorphic to \mathbf{H} by the correspondence “ $\alpha SO_2(\mathbb{R}) \mapsto \alpha i$ ”.*

§1.3. Classification of Linear Fractional Transformations

It follows from Theorem 1.1.3 that every automorphism of the upper half plane \mathbf{H} is induced by an element of $GL_2^+(\mathbb{R})$. Let us now investigate transformations induced by elements of $GL_2^+(\mathbb{R})$. We are going to classify elements of $GL_2^+(\mathbb{R})$.

A non-scalar element α of $GL_2^+(\mathbb{R})$ is called *elliptic*, *parabolic* or *hyperbolic*, when it satisfies

$$\operatorname{tr}(\alpha)^2 < 4\det(\alpha), \quad \operatorname{tr}(\alpha)^2 = 4\det(\alpha), \quad \text{or} \quad \operatorname{tr}(\alpha)^2 > 4\det(\alpha),$$

respectively. This definition applies also to the automorphisms $\iota(\alpha)$ of \mathbf{H} induced by α . We note that

the eigenvalues of α are conjugate complex numbers, a multiple real number or two distinct real numbers, respectively.

To see the geometrical meaning of the classification, we shall study the fixed points of the elements of $GL_2^+(\mathbb{R})$ as automorphisms of the Riemann sphere \mathbb{P} . Let

$\alpha = \begin{bmatrix} a & b \\ c & d \end{bmatrix}$ be a non-scalar element. First assume $c = 0$. Then $\operatorname{tr}(\alpha)^2 - 4\det(\alpha) = (a - d)^2$. Thus α is parabolic if and only if $a = d$, and in this case α has a unique fixed point ∞ . We also see that if $a \neq d$, then α is hyperbolic, and it has two fixed points $b/(d - a)$ and ∞ . Now we assume $c \neq 0$. Then the point ∞ can not be a fixed point of α . If a complex number z is a fixed point of α , then z satisfies the equation $cz^2 + (d - a)z - b = 0$. Since the discriminant of this equation is equal to $\operatorname{tr}(\alpha)^2 - 4\det(\alpha)$, the fixed points of α are conjugate complex numbers, a real number, or two distinct real numbers if α is elliptic, parabolic or hyperbolic, respectively. Thus we get the following

Theorem 1.3.1. *A non-scalar element α of $GL_2^+(\mathbb{R})$ is characterized by its fixed points on \mathbb{P} as follows:*

- (1) α is elliptic if and only if α has the fixed points z_0 and \bar{z}_0 with $z_0 \in \mathbf{H}$;
- (2) α is parabolic if and only if α has a unique fixed point on $\mathbb{R} \cup \{\infty\}$;
- (3) α is hyperbolic if and only if α has two distinct fixed points on $\mathbb{R} \cup \{\infty\}$.

For $x \in \mathbb{R} \cup \{\infty\}$, the stabilizer $GL_2^+(\mathbb{R})_x$ contains both parabolic elements and hyperbolic elements. In order to distinguish these, we put for $x, x' \in \mathbb{R} \cup \{\infty\}$ ($x \neq x'$)

$$(1.3.1) \quad GL_2^+(\mathbb{R})_x^{(p)} = \{\alpha \in GL_2^+(\mathbb{R})_x \mid \alpha \text{ is parabolic or scalar}\},$$

$$(1.3.2) \quad \begin{aligned} SL_2(\mathbb{R})_x^{(p)} &= SL_2(\mathbb{R}) \cap GL_2^+(\mathbb{R})_x^{(p)}; \\ GL_2^+(\mathbb{R})_{x,x'} &= GL_2^+(\mathbb{R})_x \cap GL_2^+(\mathbb{R})_{x'}, \end{aligned}$$

$$SL_2(\mathbb{R})_{x,x'} = SL_2(\mathbb{R}) \cap GL_2^+(\mathbb{R})_{x,x'}.$$

Lemma 1.3.2. (1) $GL_2^+(\mathbb{R})_i = \mathbb{R}^\times \cdot SO_2(\mathbb{R})$,

$$GL_2^+(\mathbb{R})_\infty = \left\{ \begin{bmatrix} a & b \\ 0 & d \end{bmatrix} \mid a, d \in \mathbb{R}^\times, b \in \mathbb{R}, ad > 0 \right\},$$

$$GL_2^+(\mathbb{R})_\infty^{(p)} = \left\{ \begin{bmatrix} a & b \\ 0 & a \end{bmatrix} \mid a \in \mathbb{R}^\times, b \in \mathbb{R} \right\},$$

$$GL_2^+(\mathbb{R})_{\infty,0} = \left\{ \begin{bmatrix} a & 0 \\ 0 & d \end{bmatrix} \mid a, d \in \mathbb{R}^\times, ad > 0 \right\}.$$

(2) The groups $GL_2^+(\mathbb{R})_z$ ($z \in \mathbf{H}$), $GL_2^+(\mathbb{R})_x^{(p)}$ ($x \in \mathbb{R} \cup \{\infty\}$) and $GL_2^+(\mathbb{R})_{x,x'}$

($x, x' \in \mathbb{R} \cup \{\infty\}$, $x \neq x'$) are conjugate to $GL_2^+(\mathbb{R})_i$, $GL_2^+(\mathbb{R})_\infty^{(p)}$ and $GL_2^+(\mathbb{R})_{\infty,0}$, respectively. Further this conjugation is given by an element of $SL_2(\mathbb{R})$.

Proof. (1): The first equality is nothing but Theorem 1.1.3(3), and the second and the third are easily seen. (2): Since $SL_2(\mathbb{R})$ acts on \mathbf{H} transitively, all stabilizers of points of \mathbf{H} are conjugate by elements of $SL_2(\mathbb{R})$. In particular, $GL_2^+(\mathbb{R})_z$ is conjugate to $GL_2^+(\mathbb{R})_i$ by an element of $SL_2(\mathbb{R})$. Furthermore, for any two distinct elements x, x' of $\mathbb{R} \cup \{\infty\}$, there exists an element $\alpha \in SL_2(\mathbb{R})$ such that $\alpha(x) = \infty$, $\alpha(x') = 0$. For such an α , we see

$$GL_2^+(\mathbb{R})_{x,x'} = \alpha^{-1} GL_2^+(\mathbb{R})_{\infty,0} \alpha, \quad GL_2^+(\mathbb{R})_x^{(p)} = \alpha^{-1} GL_2^+(\mathbb{R})_\infty^{(p)} \alpha. \quad \square$$

To see the difference of the transformations of these types, we shall give some illustrations below.

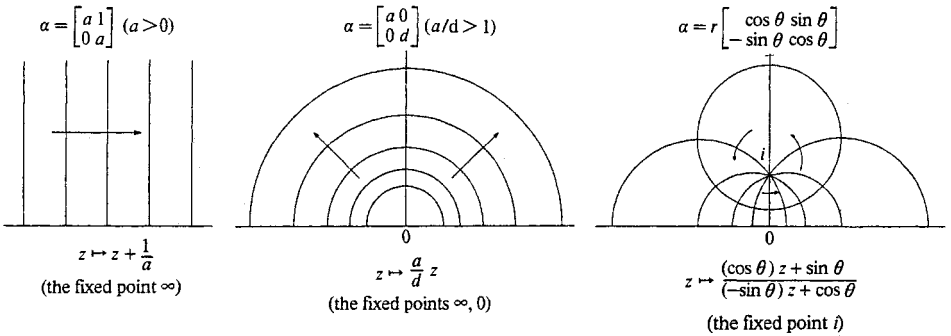

Fig. 1.3.1

We now study the centralizers of elements of $GL_2^+(\mathbb{R})$ and the normalizers of the above subgroups $GL_2^+(\mathbb{R})_z$, $GL_2^+(\mathbb{R})_x^{(p)}$ and $GL_2^+(\mathbb{R})_{x,x'}$. We calculate centralizers and normalizers not only in $GL_2^+(\mathbb{R})$ but also in $GL_2(\mathbb{R})$, since we need them in Chapter 6. We note here the property that $\alpha \in GL_2^+(\mathbb{R})$ is elliptic, parabolic or hyperbolic is invariant under the conjugation in $GL_2(\mathbb{R})$. For an element

$\alpha \in GL_2^+(\mathbb{R})$, we denote by $Z(\alpha)$ the *centralizer* of α , or

$$(1.3.3) \quad Z(\alpha) = \{\beta \in GL_2(\mathbb{R}) \mid \alpha\beta = \beta\alpha\}.$$

Now we have

Lemma 1.3.3. *For a non-scalar element α of $GL_2^+(\mathbb{R})$, we have:*

- (1) *If $\alpha \in GL_2^+(\mathbb{R})_z$, then $Z(\alpha) = Z(\alpha) \cap GL_2^+(\mathbb{R}) = GL_2^+(\mathbb{R})_z$;*
- (2) *If $\alpha \in GL_2^+(\mathbb{R})_x^{(p)}$, then $Z(\alpha) = Z(\alpha) \cap GL_2^+(\mathbb{R}) = GL_2^+(\mathbb{R})_x^{(p)}$;*
- (3) *If $\alpha \in GL_2^+(\mathbb{R})_{x,x'}$, then $[Z(\alpha): Z(\alpha) \cap GL_2^+(\mathbb{R})] = 2$ and $Z(\alpha) \cap GL_2^+(\mathbb{R}) = GL_2^+(\mathbb{R})_{x,x'}$.*

Here $z \in \mathbf{H}$ and $x, x' \in \mathbb{R} \cup \{\infty\}$ ($x \neq x'$).

Proof. Since $Z(\rho^{-1}\alpha\rho) = \rho^{-1}Z(\alpha)\rho$ for $\rho \in SL_2(\mathbb{R})$, we may assume by Lemma 1.3.2(2) that α is $r \begin{bmatrix} \cos \theta & \sin \theta \\ -\sin \theta & \cos \theta \end{bmatrix}$ ($r > 0, 0 < \theta < 2\pi, \theta \neq \pi$), $\begin{bmatrix} a & b \\ 0 & a \end{bmatrix}$ ($a, b \in \mathbb{R}^\times$), or $\begin{bmatrix} a & 0 \\ 0 & d \end{bmatrix}$ ($a, d \in \mathbb{R}^\times, ad > 0, a \neq d$). First let $\alpha = r \begin{bmatrix} \cos \theta & \sin \theta \\ -\sin \theta & \cos \theta \end{bmatrix}$, and β be an element of $Z(\alpha)$. Since $\alpha\beta i = \beta\alpha i = \beta i$, βi is also a fixed point of α . Hence $\beta i = \pm i$. If $\det(\beta) > 0$, then $\beta i = i$ and this implies $\beta \in GL_2^+(\mathbb{R})_i$. Assume that $\det(\beta) < 0$. Then (1.1.7) implies that $\beta i = -i$. Put $\beta' = \begin{bmatrix} -1 & 0 \\ 0 & 1 \end{bmatrix} \beta$. Then $\det(\beta') > 0$ and $\beta' i = i$; therefore, $\beta' \in GL_2^+(\mathbb{R})_i$. In particular, both β and β' are commutative with α , hence so is $\begin{bmatrix} -1 & 0 \\ 0 & 1 \end{bmatrix}$. On the other hand, we have

$$\begin{bmatrix} -1 & 0 \\ 0 & 1 \end{bmatrix} \alpha \begin{bmatrix} -1 & 0 \\ 0 & 1 \end{bmatrix}^{-1} = r \begin{bmatrix} \cos \theta & -\sin \theta \\ \sin \theta & \cos \theta \end{bmatrix} \neq \alpha,$$

since α is not scalar. This is a contradiction; thus $Z(\alpha) = Z(\alpha) \cap GL_2^+(\mathbb{R})$. This proves (1). The other cases can be shown by direct calculation. \square

For any subgroup G of $GL_2^+(\mathbb{R})$, we denote by $N(G)$ the *normalizer* of G in $GL_2(\mathbb{R})$; namely

$$(1.3.4) \quad N(G) = \{\alpha \in GL_2(\mathbb{R}) \mid \alpha G \alpha^{-1} = G\}.$$

Then we obtain

Lemma 1.3.4. *Let G be $GL_2^+(\mathbb{R})_z$ ($z \in \mathbf{H}$), $GL_2^+(\mathbb{R})_x^{(p)}$ ($x \in \mathbb{R} \cup \{\infty\}$), or $GL_2^+(\mathbb{R})_{x,x'}$ ($x, x' \in \mathbb{R} \cup \{\infty\}, x \neq x'$). Then $[N(G): N(G) \cap GL_2^+(\mathbb{R})] = 2$ and further*

- (1) $N(G) \cap GL_2^+(\mathbb{R}) = G$ if $G = GL_2^+(\mathbb{R})_z$,
- (2) $N(G) \cap GL_2^+(\mathbb{R}) = GL_2^+(\mathbb{R})_x$ if $G = GL_2^+(\mathbb{R})_x^{(p)}$,
- (3) $[N(G) \cap GL_2^+(\mathbb{R}): G] = 2$ if $G = GL_2^+(\mathbb{R})_{x,x'}$.

Proof. Since $N(\rho^{-1}G\rho) = \rho^{-1}N(G)\rho$ for $\rho \in GL_2^+(\mathbb{R})$, we may assume that $z = i$, $x = \infty$ and $x' = 0$. Therefore $\begin{bmatrix} -1 & 0 \\ 0 & 1 \end{bmatrix} \in N(G)$. Since $[N(G):N(G) \cap GL_2^+(\mathbb{R})] \leq [GL_2(\mathbb{R}):GL_2^+(\mathbb{R})] = 2$, and $\begin{bmatrix} -1 & 0 \\ 0 & 1 \end{bmatrix} \in N(G)$ by Lemma 1.3.2(1), we see $[N(G):N(G) \cap GL_2^+(\mathbb{R})] = 2$. Let $G = GL_2^+(\mathbb{R})_i$. If $\beta \in N(G) \cap GL_2^+(\mathbb{R})$, then $\beta i = i$, since $\beta\alpha\beta^{-1}$ has a fixed point βi for any $\alpha \in G$. This implies $\beta \in G$, and therefore, $N(G) \cap GL_2^+(\mathbb{R}) = G$. A similar argument is also applicable to $G = GL_2^+(\mathbb{R})_\infty^{(p)}$. Next assume that $G = GL_2^+(\mathbb{R})_{\infty,0}$, and let $\beta \in N(G) \cap GL_2^+(\mathbb{R})$. Then by a similar argument as above, β induces a permutation of $\{\infty, 0\}$. Then we have $[N(G) \cap GL_2^+(\mathbb{R}):G] \leq 2$. Since we see easily that $\begin{bmatrix} 0 & -1 \\ 1 & 0 \end{bmatrix} \in N(G) \cap GL_2^+(\mathbb{R})$ but $\begin{bmatrix} 0 & -1 \\ 1 & 0 \end{bmatrix} \notin G$, we have $[N(G) \cap GL_2^+(\mathbb{R}):G] = 2$ for $G = GL_2^+(\mathbb{R})_{\infty,0}$. \square

Lemma 1.3.5. (1) *Any two distinct elliptic elements in $GL_2^+(\mathbb{R})_z$ ($z \in \mathbf{H}$) are not conjugate in $GL_2^+(\mathbb{R})$.*

(2) *If two distinct parabolic elements of $GL_2^+(\mathbb{R})$ are conjugate by a matrix of negative determinant, then they are not conjugate in $GL_2^+(\mathbb{R})$.*

Proof. (1): Let α and β be elliptic elements such that $\beta = \delta\alpha\delta^{-1}$ with $\delta \in GL_2^+(\mathbb{R})$. Then δz is also a fixed point of β , and therefore, $\delta z = z$. This implies that $\delta \in GL_2^+(\mathbb{R})_z$. Since α and δ are commutative, we get $\alpha = \beta$. (2): Let α and β be distinct parabolic elements. Assume that $\beta = \gamma\alpha\gamma^{-1} = \delta\alpha\delta^{-1}$ with $\gamma, \delta \in GL_2(\mathbb{R})$ such that $\det(\gamma) < 0$ and $\det(\delta) > 0$. Then $\delta^{-1}\gamma \in Z(\alpha)$. Since $\det(\delta^{-1}\gamma) < 0$, this contradicts Lemma 1.3.3(2). \square

§1.4. The Invariant Metric and Measure on \mathbf{H}

In the upper half plane \mathbf{H} , there exist a metric and a measure which are invariant under the action of $GL_2^+(\mathbb{R})$. Such a metric is unique up to a constant multiplication and is called the Poincaré metric. For a differentiable function $f(z)$ on \mathbf{H} , we define the *differential* df by

$$df = \left(\frac{\partial f}{\partial x} \right) dx + \left(\frac{\partial f}{\partial y} \right) dy$$

considering f as a function of $x = \operatorname{Re}(z)$ and $y = \operatorname{Im}(z)$. Further for $\alpha \in GL_2^+(\mathbb{R})$, we put

$$(f \circ \alpha)(z) = f(\alpha z), \quad (df) \circ \alpha = d(f \circ \alpha).$$

Then for z and \bar{z} and for $\alpha \in GL_2^+(\mathbb{R})$, we have

$$(1.4.1) \quad \begin{aligned} dz &= dx + idy, & d\bar{z} &= dx - idy, \\ dz \circ \alpha &= \left(\frac{d(\alpha z)}{dz} \right) dz, & d\bar{z} \circ \alpha &= \left(\overline{\frac{d(\alpha z)}{dz}} \right) d\bar{z}. \end{aligned}$$

Further we define the metric ds^2 and the measure dv on \mathbf{H} by

$$(1.4.2) \quad ds^2(z) = \frac{dx^2 + dy^2}{y^2}, \quad dv(z) = \frac{dx dy}{y^2}.$$

We note that $dx^2 + dy^2 = dz \cdot d\bar{z}$, $dx \wedge dy = \frac{1}{2} dz \wedge d\bar{z}$ and

$$(1.4.3) \quad \frac{d(\alpha z)}{dz} = \det(\alpha) j(\alpha, z)^{-2} \quad (\alpha \in GL_2^+(\mathbb{R}), z \in \mathbf{H}).$$

Therefore ds^2 and dv are invariant under the action of $GL_2^+(\mathbb{R})$ by (1.4.1) and (1.1.7).

Let ϕ be an injective continuous mapping from the interval $[0, 1]$ into \mathbf{H} which is C^∞ except for finitely many points. Then the image C of ϕ is called a *curve* on \mathbf{H} . Then by definition its *length* is

$$l(C) = \int_0^1 ds(\phi(t)) = \int_0^1 \frac{\sqrt{(dx(t)/dt)^2 + (dy(t)/dt)^2}}{y(t)} dt \quad (\phi(t) = x(t) + iy(t)),$$

which depends only on C .

Since \mathbf{H} is isomorphic to the unit disk \mathbf{K} through $\rho = \begin{bmatrix} 1 & -i \\ 1 & i \end{bmatrix}$, we can define the metric $ds_{\mathbf{K}}^2$ and the measure $dv_{\mathbf{K}}$ on \mathbf{K} by

$$ds_{\mathbf{K}}^2 = ds^2 \circ \rho^{-1}, \quad dv_{\mathbf{K}} = dv \circ \rho^{-1}.$$

By (1.1.8), they are invariant under the action of $SU(1, 1)$. More explicitly, $ds_{\mathbf{K}}^2$ and $dv_{\mathbf{K}}$ can be expressed as

$$ds_{\mathbf{K}}^2(w) = \frac{4(dx^2 + dy^2)}{(1 - |w|^2)^2},$$

$$dv_{\mathbf{K}}(w) = \frac{4dx dy}{(1 - |w|^2)^2} \quad (w = x + iy \in \mathbf{K}).$$

We denote by $l_{\mathbf{K}}(C_{\mathbf{K}})$ the length of a curve $C_{\mathbf{K}}$ on \mathbf{K} . Then for a curve C on \mathbf{H} , we see that

$$l_{\mathbf{K}}(\rho(C)) = l(C).$$

Among the curves joining two points z_1 and z_2 , the shortest one is called a *geodesic*. We note that a curve C on \mathbf{H} is a geodesic if and only if $\rho(C)$ is a geodesic on \mathbf{K} . The existence and the uniqueness of a geodesic will be shown in the following

- Lemma 1.4.1.** (1) Any two points on \mathbf{H} are joined by a unique geodesic which is a part of a circle orthogonal to the real axis or a line orthogonal to the real axis.
 (2) Any two points on \mathbf{K} are joined by a unique geodesic which is a part of a diameter of \mathbf{K} or a part of a circle orthogonal to the unit circle.

Proof. Since ρ is a conformal mapping, we have only to prove (2) by Lemma 1.1.1. Let $z_1, z_2 \in \mathbf{K}$. Since $SU(1, 1)$ acts transitively on \mathbf{K} , we may assume that $z_1 = 0$. Moreover, $SU(1, 1)$ contains $\rho SO_2(\mathbb{R})\rho^{-1}$ whose elements give rotations with center 0; thus we may also assume that z_2 is a positive real number x_0 . Let C_0 be a horizontal line segment between 0 and x_0 , and C be another curve joining 0 and x_0 . Let C be parametrized by ϕ and put $\phi(t) = x(t) + iy(t)$. Then

$$\begin{aligned} l_{\mathbf{K}}(C) &= \int_0^1 2(1 - |\phi(t)|^2)^{-1} \sqrt{(dx(t)/dt)^2 + (dy(t)/dt)^2} dt \\ &\geq \int_0^1 2(1 - x(t)^2)^{-1} |dx(t)/dt| dt \\ &\geq \int_0^{x_0} 2(1 - x^2)^{-1} dx \\ &= l_{\mathbf{K}}(C_0). \end{aligned}$$

The equality holds only when $C = C_0$. Therefore C_0 is a unique geodesic. \square

For any two points z_1 and z_2 of \mathbf{H} (resp. \mathbf{K}), we call the length of the geodesic joining z_1 and z_2 the *distance* of z_1 and z_2 , and denote it by $d(z_1, z_2)$.

Corollary 1.4.2. (1) *Let z_0 be a point of \mathbf{H} (resp. \mathbf{K}), and C the set consisting of all points of \mathbf{H} (resp. \mathbf{K}) of the same distance from z_0 . Then C is a circle orthogonal to every geodesic passing through z_0 .*

(2) *Let z_1 and z_2 be two distinct points of \mathbf{H} (resp. \mathbf{K}), and C the set consisting of all points of \mathbf{H} (resp. \mathbf{K}) which have the same distances from z_1 and z_2 . Then C is a geodesic on \mathbf{H} (resp. \mathbf{K}).*

Proof. It is sufficient to prove our assertions only for \mathbf{K} . (1): Since $SU(1, 1)$ acts transitively on \mathbf{K} , we may assume that $z_0 = 0$. The distance from 0 is invariant by rotations with center 0. Therefore, in this case, C is a circle with center 0. (2): Mapping the middle point of the geodesic joining z_1 and z_2 into 0 by an element of $SU(1, 1)$, we may assume that $z_1 = iy_0$ and $z_2 = -iy_0$ ($0 < y_0 < 1$). For $d > 0$, let C_v ($v = 1, 2$) be the set consisting of the points which have the distance d from z_v . Then C_v is a circle by (1). Since the metric on \mathbf{K} is invariant by the transformation $(x, y) \mapsto (x, -y)$, C_1 and C_2 are symmetric with respect to the real axis. Therefore, the intersection points of C_1 and C_2 lie on the real axis. Conversely, by a similar argument as above, every point on the real axis has equal distance from z_1 and z_2 . \square

Let α be an elliptic element of $SL_2(\mathbb{R})$ which fixes z_0 , and ρ an isomorphism of \mathbf{H} onto \mathbf{K} such that $\rho(z_0) = 0$. Then we see

$$\rho\alpha\rho^{-1} = \beta, \quad \beta = \begin{bmatrix} e^{i\theta} & 0 \\ 0 & e^{-i\theta} \end{bmatrix} \quad (-\pi < \theta < \pi).$$

Since $\alpha z_0 = z_0$, it follows from (1.1.5) that

$$(1.4.4) \quad j(\beta, 0) = j(\rho, z_0)j(\alpha, z_0)j(\rho^{-1}, 0) = j(\alpha, z_0).$$

Thus we get

$$(1.4.5) \quad \arg(j(\alpha, z_0)) = \arg(j(\beta, 0)) = -\theta.$$

Since ρ is conformal,

$$(1.4.6) \quad \text{the angle between a geodesic passing through } z_0 \text{ and its image by } \alpha \text{ is } 2\theta.$$

Lemma 1.4.3. *For any $\alpha \in SL_2(\mathbb{R})$, we have:*

- (1) $(y^{-1} dz) \circ \alpha - y^{-1} dz = -2id[\log(j(\alpha, z))];$
- (2) $(y^{-1} dx) \circ \alpha - y^{-1} dx = 2d[\arg(j(\alpha, z))].$

Proof. (1): Put $\alpha = \begin{bmatrix} * & * \\ c & * \end{bmatrix}$. By (1.1.7), (1.4.1) and (1.4.3),

$$\begin{aligned} (y^{-1} dz) \circ \alpha - y^{-1} dz &= (|j(\alpha, z)|^2 j(\alpha, z)^{-2} - 1) y^{-1} dz \\ &= -2icj(\alpha, z)^{-1} dz \\ &= -2id[\log(j(\alpha, z))]. \end{aligned}$$

(2): Taking the real parts of both sides of the equality (1), we get the second one. \square

Lemma 1.4.4. *Let D be the interior of a triangle on $\mathbf{H} \cup \mathbb{R} \cup \{\infty\}$ whose sides are geodesics with angles θ_1, θ_2 and θ_3 . Then the area of D is given by*

$$v(D) = \pi - (\theta_1 + \theta_2 + \theta_3).$$

Proof. Let z_1, z_2 and z_3 be the apices of D corresponding to θ_1, θ_2 and θ_3 , respectively. First assume that all z_i are in \mathbf{H} . Let x_{ij} be the intersection point of the extension of the side $z_i z_j$ and $\mathbb{R} \cup \{\infty\}$ (see Figure 1.4.1). We denote by ∂D the positively oriented boundary of D . Since

$$d(y^{-1} dx) = y^{-2} dx \wedge dy,$$

we see by the Stokes theorem that

$$\begin{aligned} \int_D y^{-2} dx dy &= \int_{\partial D} y^{-1} dx \\ &= \left(\int_{z_1}^{z_2} + \int_{z_2}^{z_3} + \int_{z_3}^{z_1} \right) y^{-1} dx \\ &= \left(\int_{z_1}^{x_{12}} + \int_{x_{12}}^{z_2} + \int_{z_2}^{x_{32}} + \int_{x_{32}}^{z_3} + \int_{z_3}^{x_{31}} + \int_{x_{31}}^{z_1} \right) y^{-1} dx. \end{aligned}$$

For any real number x_0 , we put

$$z - x_0 = re^{i\theta}.$$

Then on the circle $|z - x_0| = r$, we have

$$(1.4.7) \quad y^{-1} dx = -d\theta.$$

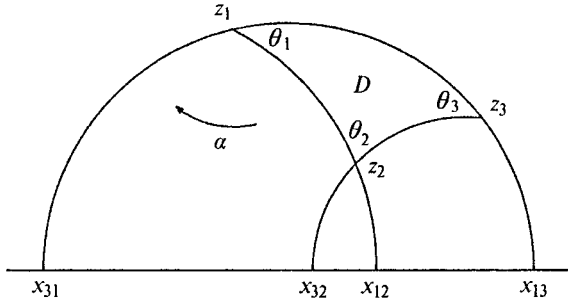

Fig. 1.4.1

Therefore each integral is finite. Let $\alpha \in SL_2(\mathbb{R})$ be an elliptic element which fixes z_1 and maps x_{12} to x_{31} and $j(\alpha, x_{12}) > 0$. Then by Lemma 1.4.3(2), (1.4.5) and (1.4.6), we see that

$$\begin{aligned} \int_{z_1}^{x_{12}} y^{-1} dx &= \int_{z_1}^{x_{12}} y^{-1} dx \circ \alpha - \int_{z_1}^{x_{12}} 2d[\arg(j(\alpha, z))] \\ &= \int_{z_1}^{x_{31}} y^{-1} dx - [2 \arg(j(\alpha, z))]_{z_1}^{x_{12}} \\ &= \int_{z_1}^{x_{31}} y^{-1} dx + (\pi - \theta_1). \end{aligned}$$

Similarly we obtain

$$\begin{aligned} \int_{x_{12}}^{z_2} y^{-1} dx &= \int_{x_{32}}^{z_2} y^{-1} dx - \theta_2, \\ \int_{x_{32}}^{z_3} y^{-1} dx &= \int_{x_{13}}^{z_3} y^{-1} dx + (\pi - \theta_3). \end{aligned}$$

Therefore

$$\int_D y^{-2} dx dy = \int_{x_{13}}^{x_{31}} y^{-1} dx + (\pi - \theta_1) - \theta_2 + (\pi - \theta_3).$$

Let x_0 be the center of the arc $x_{31}z_1z_3x_{13}$ and put

$$z - x_0 = (x - x_0) + iy = re^{i\theta}.$$

Then by (1.4.7), we have

$$\int_{x_{13}}^{x_{31}} y^{-1} dx = - \int_0^\pi d\theta = -\pi.$$

Consequently we obtain $v(D) = \pi - (\theta_1 + \theta_2 + \theta_3)$. Next we consider the case where some vertices are on $\mathbb{R} \cup \{\infty\}$. Dividing the triangle into pieces, we may assume that the only one vertex is on $\mathbb{R} \cup \{\infty\}$. Moreover since $SL_2(\mathbb{R})$ acts transitively on $\mathbb{R} \cup \{\infty\}$, we may assume that it is the point ∞ . Renumbering the indices, we may take $z_1 = \infty$. Hence $\theta_1 = 0$. Put $x_0 = \text{Re}(z_2 + z_3)/2$, and let z_4 (resp. z_5) be the intersection point of the line $\text{Re}(z) = \text{Re}(z_2)$ (resp. $\text{Re}(z) = \text{Re}(z_3)$)

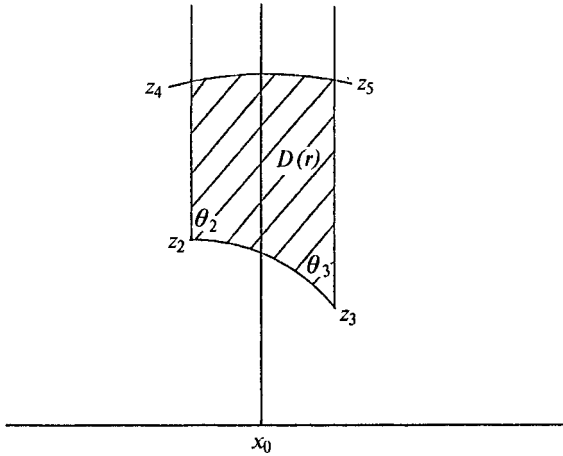

Fig. 1.4.2

and a circle with center x_0 of sufficiently long radius r (see Figure 1.4.2). We denote by $D(r)$ the square with vertices z_2, z_3, z_5, z_4 . Then from the above result, we have

$$v(D) = 2\pi - (\theta_2 + \theta_3 + \angle z_4 + \angle z_5).$$

Since both $\angle z_4$ and $\angle z_5$ converge to $\pi/2$ and $\theta_1 = 0$, we have

$$\begin{aligned} v(D) &= \lim_{r \rightarrow \infty} v(D(r)) \\ &= \pi - (\theta_2 + \theta_3) \\ &= \pi - (\theta_1 + \theta_2 + \theta_3). \end{aligned} \quad \square$$

We call a measure μ on a locally compact group G a *Haar measure* if the following two conditions are satisfied:

- (i) any compact subset of G is measurable;
- (ii) μ is invariant under left translation by G .

It is known that there always exists a Haar measure and that it is uniquely determined up to a constant factor. We say that G is *unimodular* if a Haar measure of G is also invariant under right translation by G .

We shall give an explicit form of a Haar measure of $SL_2(\mathbb{R})$. Put

$$(1.4.8) \quad h_z = \sqrt{y}^{-1} \begin{bmatrix} y & x \\ 0 & 1 \end{bmatrix} \in SL_2(\mathbb{R}) \quad (z = x + iy \in \mathbf{H}).$$

Let $\alpha \in SL_2(\mathbb{R})$ and $z = \alpha i$. Then $h_z^{-1} \alpha i = i$; hence we have $h_z^{-1} \alpha = k_\theta$ with

$$(1.4.9) \quad k_\theta = \begin{bmatrix} \cos \theta & \sin \theta \\ -\sin \theta & \cos \theta \end{bmatrix} \in SO_2(\mathbb{R}).$$

Namely, any $\alpha \in SL_2(\mathbb{R})$ can be expressed as

$$(1.4.10) \quad \alpha = h_z k_\theta \quad (z \in \mathbf{H}, \quad k_\theta \in SO_2(\mathbb{R})).$$

Conversely, if α is written as (1.4.10), we see that

$$(1.4.11) \quad z = \alpha i, \quad \theta = -\arg(j(\alpha, i)).$$

Therefore both z and θ are uniquely determined by α . Further put $\alpha = \begin{bmatrix} a & b \\ c & d \end{bmatrix}$.

Then we see easily that x, y, θ are all C^∞ functions of a, b, c, d , and conversely, a, b, c, d are also C^∞ functions of x, y, θ . Consequently, we obtain isomorphisms as manifolds:

$$(1.4.12) \quad SL_2(\mathbb{R}) \simeq \mathbf{H} \times SO_2(\mathbb{R}) \simeq \mathbf{H} \times \mathbb{C}^1.$$

We define a measure of $SL_2(\mathbb{R})$ by

$$(1.4.13) \quad d\alpha = (2\pi)^{-1} y^{-2} dx dy d\theta.$$

For any $\alpha_1 \in SL_2(\mathbb{R})$, we have

$$(1.4.14) \quad \alpha_1 \alpha = h_{\alpha_1 z} k_{\theta + \phi}, \quad \phi = -\arg(j(\alpha_1, z)).$$

Since $y^{-2} dx \wedge dy$ is invariant under the action of $SL_2(\mathbb{R})$ and ϕ is independent of θ , we see for $\alpha_1 z = x' + iy'$,

$$y'^{-2} dx' \wedge dy' \wedge d(\theta + \phi) = y^{-2} dx \wedge dy \wedge (d\theta + d\phi) = y^{-2} dx \wedge dy \wedge d\theta.$$

This implies that $d\alpha$ is a Haar measure of $SL_2(\mathbb{R})$. Further put $\alpha_1 = h_{z_1} k_{\theta_1}$, $z_1 = x_1 + iy_1$ and define z', θ' by

$$\alpha \alpha_1 = h_{z'} k_{\theta'}, \quad z' = x' + iy'.$$

Then we see easily that

$$x' = \frac{y\{(1 - |z_1|^2)\sin\theta \cos\theta + x_1 \cos 2\theta\}}{|\cos\theta - z_1 \sin\theta|^2} + x,$$

$$y' = \frac{yy_1}{|\cos\theta - z_1 \sin\theta|^2},$$

$$\theta' = -\arg(\cos\theta - z_1 \sin\theta) + \theta_1 + 2n\pi$$

with $n \in \mathbb{Z}$. Therefore we have

$$y'^{-2} dx' \wedge dy' \wedge d\theta' = y^{-2} dx \wedge dy \wedge d\theta.$$

This implies that $d\alpha$ is invariant under right translation of G . Thus we obtain

Theorem 1.4.5. $SL_2(\mathbb{R})$ is unimodular. Further if $f(z)$ is a measurable function on \mathbf{H} , " $\alpha \mapsto f(\alpha i)$ " is also measurable on $SL_2(\mathbb{R})$ and

$$\int_{\mathbf{H}} f(z) dv(z) = \int_{SL_2(\mathbb{R})} f(\alpha i) d\alpha.$$

§ 1.5. Fuchsian Groups

Let Γ be a group acting on a topological space X . We say that a group Γ *acts properly discontinuously on X* if for any two points x, y of X , there exist neighborhoods U of x and V of y such that

$$\#\{\gamma \in \Gamma \mid \gamma U \cap V \neq \emptyset\} < \infty.$$

If X is locally compact, this is equivalent to saying that for any compact subsets A, B of X ,

$$\#\{\gamma \in \Gamma \mid \gamma A \cap B \neq \emptyset\} < \infty.$$

A subgroup Γ of a topological group G is called a *discrete subgroup* if Γ is discrete with respect to the topology of G .

Theorem 1.5.1. *If Γ is a discrete subgroup of G , then Γ is a closed subgroup without accumulation points.*

Proof. By definition there exists a neighborhood U of 1 satisfying $U \cap \Gamma = \{1\}$. Let V be any neighborhood of 1 such that $V^{-1}V \subset U$. Then for any two distinct points α, β of Γ , we have $V\alpha \cap V\beta = \emptyset$. Let g be an element of the closure of Γ and $\alpha \in V^{-1}g \cap \Gamma$. Then we see $V^{-1}g \cap \Gamma = \{\alpha\}$, so that we get $g = \alpha \in \Gamma$. \square

Theorem 1.5.2. *Let G and X be as in Theorem 1.2.1, and Γ a subgroup of G . If all stabilizers of elements of G are compact, then the following statements are equivalent:*

- (1) Γ is discrete;
- (2) Γ acts properly discontinuously on X .

Proof. (1) \Rightarrow (2): Let x be an element of X , and A, B two compact subsets of X . Put

$$M = \{g \in G \mid gx \in A\}, \quad N = \{g \in G \mid gx \in B\}.$$

Since G acts transitively on X , we see $A = Mx$. Take open subsets U_ν of G so that $M \subset \bigcup_\nu U_\nu$ and \bar{U}_ν are compact. This is possible since G is locally compact. Then $A \subset \bigcup_\nu U_\nu x$. Since $U_\nu x$ is open by Theorem 1.2.1 and A is compact, we can choose finitely many U_ν so that $A \subset \bigcup_{\nu=1}^n U_\nu x$. Hence $M \subset \bigcup_{\nu=1}^n \bar{U}_\nu G_x$. Since $\bar{U}_\nu G_x$ is compact and M is closed, M is also compact. Similarly N is compact. Since Γ is discrete and NM^{-1} is compact, $\{\gamma \in \Gamma \mid \gamma A \cap B \neq \emptyset\} = \Gamma \cap NM^{-1}$ is also discrete and compact; therefore it is a finite set. (2) \Rightarrow (1): Let V be any neighborhood of 1 in G such that \bar{V} is compact. For a point $x \in X$, $\Gamma \cap V$ is included in the set $\{\gamma \in \Gamma \mid \gamma x \in \bar{V}x\}$ which is finite, since both $\{x\}$ and $\bar{V}x$ are compact in X . Hence we can take V so that $\Gamma \cap V = \{1\}$. \square

Theorem 1.5.2 and Theorem 1.1.3(2) imply the following

Corollary 1.5.3. *Any discrete subgroup of $SL_2(\mathbb{R})$ acts properly discontinuously on the upper half plane \mathbf{H} . Conversely, any subgroup of $\text{Aut}(\mathbf{H})$ which acts properly discontinuously on \mathbf{H} is obtained from a discrete subgroup of $SL_2(\mathbb{R})$.*

We call a discrete subgroup of $SL_2(\mathbb{R})$ a *Fuchsian group*. Hereafter we assume that Γ is a Fuchsian group, and put

$$Z(\Gamma) = \Gamma \cap \{\pm 1\}.$$

If ι is the homomorphism of $SL_2(\mathbb{R})$ onto $\text{Aut}(\mathbf{H})$ as in §1.1, then Theorem 1.1.3 implies

$$\iota(\Gamma) \simeq \Gamma/Z(\Gamma).$$

When $z \in \mathbf{H} \cup \mathbb{R} \cup \{\infty\}$ is a fixed point of an elliptic, parabolic or hyperbolic element of Γ , we say that z is an *elliptic point*, a *parabolic point* or a *hyperbolic point* of Γ , respectively. We also call a parabolic point of Γ a *cuspidal point* of Γ . For $z \in \mathbf{H}$ and $x, x' \in \mathbb{R} \cup \{\infty\}$, we put

$$\Gamma_z = \Gamma \cap SL_2(\mathbb{R})_z, \quad \Gamma_x = \Gamma \cap SL_2(\mathbb{R})_x, \quad \Gamma_{x,x'} = \Gamma \cap SL_2(\mathbb{R})_{x,x'}.$$

Theorem 1.5.4. (1) *If $z \in \mathbf{H}$ is an elliptic point of Γ , then Γ_z is a finite cyclic group.*

(2) *If $x \in \mathbb{R} \cup \{\infty\}$ is a cuspidal point of Γ , then $\Gamma_x \subset SL_2(\mathbb{R})_x^{(p)}$ and*

$$\Gamma_x/Z(\Gamma) \simeq \mathbb{Z}.$$

Moreover for $\sigma \in SL_2(\mathbb{R})$ such that $\sigma x = \infty$, we have

$$\sigma \Gamma_x \sigma^{-1} \cdot \{\pm 1\} = \left\{ \pm \begin{bmatrix} 1 & h \\ 0 & 1 \end{bmatrix}^m \mid m \in \mathbb{Z} \right\} \quad (h > 0).$$

(3) *If $\Gamma_{x,x'} \neq Z(\Gamma)$ for $x, x' \in \mathbb{R} \cup \{\infty\}$ ($x \neq x'$), then*

$$\Gamma_{x,x'}/Z(\Gamma) \simeq \mathbb{Z}.$$

Moreover there exists $\sigma \in SL_2(\mathbb{R})$ such that

$$\sigma \Gamma_{x,x'} \sigma^{-1} \cdot \{\pm 1\} = \left\{ \pm \begin{bmatrix} u & 0 \\ 0 & u^{-1} \end{bmatrix}^m \mid m \in \mathbb{Z} \right\} \quad (u > 0).$$

Proof. (1): Since $SL_2(\mathbb{R})$ acts transitively on \mathbf{H} , $SL_2(\mathbb{R})_z$ is conjugate to $SL_2(\mathbb{R})_i = SO_2(\mathbb{R})$ which is a compact abelian group isomorphic to \mathbb{C}^1 . Therefore $\Gamma_z = \Gamma \cap SL_2(\mathbb{R})_z$ is finite. Since any finite subgroup of \mathbb{C}^1 is cyclic, Γ_z is cyclic.

(2): We may assume $x = \infty$ by taking $\sigma \Gamma \sigma^{-1}$ in place of Γ . Hence there exists an element γ of the form $\begin{bmatrix} 1 & l \\ 0 & 1 \end{bmatrix}$ ($l \neq 0$) in Γ_∞ . Suppose that $\alpha \in \Gamma_\infty$ is neither parabolic nor scalar. Then we can write $\alpha = \begin{bmatrix} a & b \\ 0 & a^{-1} \end{bmatrix}$ with $a \neq \pm 1$. We may assume $|a| < 1$ by taking α^{-1} in place of α , if necessary. We get

$$\alpha^n \gamma \alpha^{-n} = \begin{bmatrix} 1 & a^{2n} l \\ 0 & 1 \end{bmatrix} \in \Gamma$$

for any positive integer n . This contradicts that Γ is discrete; therefore

$$\Gamma_\infty \subset SL_2(\mathbb{R})_\infty^{(p)} = \left\{ \pm \begin{bmatrix} 1 & b \\ 0 & 1 \end{bmatrix} \mid b \in \mathbb{R} \right\}.$$

Since $SL_2(\mathbb{R})_\infty^{(p)}/\{\pm 1\}$ is isomorphic to \mathbb{R} as topological groups, we obtain (2). (3):

It follows from Lemma 1.3.2 that there exists $\sigma \in SL_2(\mathbb{R})$ such that

$$\sigma \Gamma_{x,x'} \sigma^{-1} \subset \sigma SL_2(\mathbb{R})_{x,x'} \sigma^{-1} = SL_2(\mathbb{R})_{\infty,0} = \left\{ \begin{bmatrix} a & 0 \\ 0 & a^{-1} \end{bmatrix} \mid a \in \mathbb{R}^\times \right\}.$$

Since discrete subgroups of $\mathbb{R}^\times / \{\pm 1\}$ are cyclic, we obtain (3). □

For $z \in \mathbf{H}$, we put

$$e_z = |\Gamma_z / Z(\Gamma)|$$

and call it the *order* of z with respect to Γ . Then z is an elliptic point of Γ if and only if $e_z > 1$. For a cusp x of Γ , we also put $e_x = \infty$ and call it the *order* of a cusp x of Γ . By the above theorem, we see that

(1.5.1) *the order of an elliptic point is finite;*

(1.5.2) *a cusp of Γ cannot be a hyperbolic point of Γ .*

Corollary 1.5.5. *If Γ' is a subgroup of a Fuchsian group Γ of finite index, then the set of the cusps of Γ' coincides with that of Γ .*

Proof. Since a cusp of Γ' is also that of Γ , it is sufficient to prove the converse. Let x be a cusp of Γ . Since

$$[\Gamma_x : \Gamma' \cap \Gamma_x] \leq [\Gamma : \Gamma'] < \infty,$$

we see from Theorem 1.5.4(2) that $\Gamma'_x = \Gamma' \cap \Gamma_x \neq Z(\Gamma)$. This shows that x is also a cusp of Γ' . □

We are going to discuss the case $-1 \notin \Gamma$ for a while. Let x be a cusp of Γ and σ an element of $SL_2(\mathbb{R})$ such that $\sigma x = \infty$. Then it follows from Theorem 1.5.4(2) that there exists $h > 0$ such that

$$\sigma \Gamma_x \sigma^{-1} \cdot \{\pm 1\} = \left\{ \pm \begin{bmatrix} 1 & h \\ 0 & 1 \end{bmatrix}^m \mid m \in \mathbb{Z} \right\}.$$

Since $-1 \notin \Gamma$, $\sigma \Gamma_x \sigma^{-1}$ contains either $\begin{bmatrix} 1 & h \\ 0 & 1 \end{bmatrix}$ or $\begin{bmatrix} -1 & h \\ 0 & -1 \end{bmatrix}$. We say that a cusp x is *regular* or *irregular*, respectively. We will see that this definition is independent of the choice of σ in the following

Lemma 1.5.6. *Assume $-1 \notin \Gamma$.*

- (1) *The regularity of a cusp x of Γ is independent of the choice of σ .*
- (2) *The order of any elliptic point of Γ is odd.*

Proof. Let $\sigma_1, \sigma_2 \in SL_2(\mathbb{R})$ such that $\sigma_1 x = \sigma_2 x = \infty$. Since $\sigma_2 \sigma_1^{-1} \infty = \infty$, we can write $\sigma_2 \sigma_1^{-1} = \begin{bmatrix} a & b \\ 0 & a^{-1} \end{bmatrix}$. Then for $\gamma \in \Gamma_x$ such that $\sigma_1 \gamma \sigma_1^{-1} = \begin{bmatrix} 1 & h \\ 0 & 1 \end{bmatrix}$ (resp. $\begin{bmatrix} -1 & h \\ 0 & -1 \end{bmatrix}$), we have

$$\sigma_2 \gamma \sigma_2^{-1} = \begin{bmatrix} 1 & a^2 h \\ 0 & 1 \end{bmatrix} \quad \left(\text{resp.} \begin{bmatrix} -1 & a^2 h \\ 0 & -1 \end{bmatrix} \right).$$

This proves (1). Now let z be an elliptic point of Γ . Applying Theorem 1.5.4 for $\Gamma' = \Gamma \cdot \{\pm 1\}$, we see that $\Gamma'_z = \Gamma_z \cdot \{\pm 1\}$ is cyclic. Hence Γ'_z contains a unique element -1 of order 2 in $SL_2(\mathbb{R})$. Since $-1 \notin \Gamma$, Γ_z has no element of order 2. Therefore the order of the cyclic group Γ_z is odd. \square

Example 1.5.1. Let $\alpha \in SL_2(\mathbb{R})$. The cyclic group $\langle \alpha \rangle$ generated by α is a discrete subgroup of $SL_2(\mathbb{R})$ if α is either parabolic or hyperbolic. When α is elliptic, $\langle \alpha \rangle$ is discrete only if α is of finite order.

Example 1.5.2. Let \mathfrak{R} be a compact Riemann surface and assume that its genus $g > 1$. Then the universal covering of \mathfrak{R} is isomorphic to \mathbf{H} . We fix this isomorphism and consider the homotopy group $\pi_1(\mathfrak{R})$ of \mathfrak{R} as a subgroup of $\text{Aut}(\mathbf{H})$. Then the subgroup $\Gamma = \iota^{-1}(\pi_1(\mathfrak{R}))$ of $SL_2(\mathbb{R})$ is a Fuchsian group. Moreover Γ contains neither elliptic elements nor parabolic elements. (We shall give the definitions of the Riemann surfaces and their genera in §1.8.)

Example 1.5.3. Let

$$\begin{aligned} \Gamma &= SL_2(\mathbb{Z}) \\ &= \left\{ \begin{bmatrix} a & b \\ c & d \end{bmatrix} \in SL_2(\mathbb{R}) \mid a, b, c, d \in \mathbb{Z} \right\}. \end{aligned}$$

Since $SL_2(\mathbb{Z}) = M_2(\mathbb{Z}) \cap SL_2(\mathbb{R})$ and $M_2(\mathbb{Z})$ is discrete in $M_2(\mathbb{R})$, $SL_2(\mathbb{Z})$ is a discrete subgroup of $SL_2(\mathbb{R})$, namely, a Fuchsian group. We call Γ or its subgroups of finite index *modular groups*. We shall study these groups in detail in Chapter 4.

Example 1.5.4. Let B be an indefinite quaternion algebra over \mathbb{Q} and R an order of B . We may identify $B \otimes_{\mathbb{Q}} \mathbb{R}$ with $M_2(\mathbb{R})$, and then R is discrete in $M_2(\mathbb{R})$. Therefore $\Gamma = R \cap SL_2(\mathbb{R})$ is a Fuchsian group. Example 1.5.3 is a special case of this. (We shall discuss quaternion algebras in Chapter 5.)

§1.6. Fundamental Domains

To study the quotient space $\Gamma \backslash \mathbf{H}$ for a Fuchsian group Γ , it is useful if there exists a connected domain of \mathbf{H} which represents $\Gamma \backslash \mathbf{H}$. Such a domain is called a *fundamental domain* of Γ .

Let Γ be a Fuchsian group and F a connected domain of \mathbf{H} . We call F a *fundamental domain* of Γ if F satisfies the following three conditions:

- (i) $\mathbf{H} = \bigcup_{\gamma \in \Gamma} \gamma F$;
- (ii) $F = \bar{U}$ with an open set U consisting of all the interior points of F ;
- (iii) $\gamma U \cap U = \emptyset$ for any $\gamma \in \Gamma - Z(\Gamma)$.

Put, for example,

$$\begin{aligned} \Gamma_1 &= \left\{ \begin{bmatrix} 1 & n \\ 0 & 1 \end{bmatrix} \mid n \in \mathbb{Z} \right\}, \\ \Gamma_2 &= \left\langle \begin{bmatrix} \cos \pi/3 & \sin \pi/3 \\ -\sin \pi/3 & \cos \pi/3 \end{bmatrix} \right\rangle. \end{aligned}$$

Then we can take as fundamental domains of Γ_1 and Γ_2 the domains F_1 and F_2 shown by the figures below.

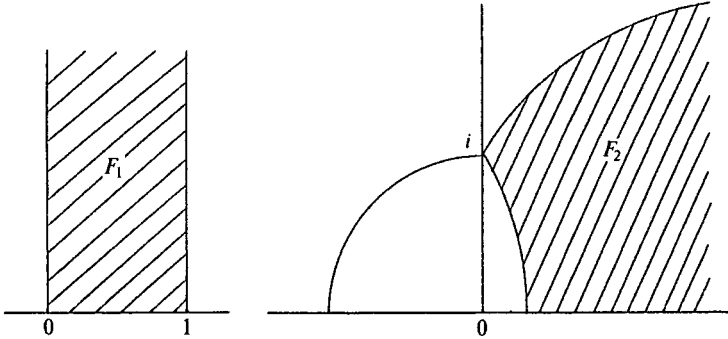

Fig. 1.6.1

Now let us show that any Fuchsian group Γ has a fundamental domain. We fix a point $z_0 \in \mathbf{H}$ which is not an elliptic point of Γ . For $\gamma \in \Gamma - Z(\Gamma)$, we put

$$F_\gamma = \{z \in \mathbf{H} \mid d(z, z_0) \leq d(z, \gamma z_0)\},$$

$$U_\gamma = \{z \in \mathbf{H} \mid d(z, z_0) < d(z, \gamma z_0)\},$$

$$C_\gamma = \{z \in \mathbf{H} \mid d(z, z_0) = d(z, \gamma z_0)\}.$$

Here $d(\cdot, \cdot)$ indicates the distance on \mathbf{H} defined in §1.4. We note that C_γ is a geodesic by Corollary 1.4.2(2).

Lemma 1.6.1. *For any compact subset M of \mathbf{H} , $\#\{\gamma \in \Gamma - Z(\Gamma) \mid M \cap C_\gamma \neq \emptyset\}$ is finite.*

Proof. Put

$$M_r = \{z \in \mathbf{H} \mid d(z, z_0) \leq r\}$$

for $r > 0$, where z_0 is the point taken above. Assume that $M_r \cap C_\gamma \neq \emptyset$. Then we have $\gamma z_0 \in M_{2r}$, since

$$d(z_0, \gamma z_0) \leq d(z_0, z) + d(z, \gamma z_0) \leq 2r$$

for $z \in M_r \cap C_\gamma$. Since M_{2r} is compact, the number of such a γ is finite. This implies the assertion since M is contained in M_r for some r . □

We define the subsets F and U of \mathbf{H} by

$$(1.6.1) \quad F = \bigcap_{\gamma \in \Gamma} F_\gamma$$

$$= \{z \in \mathbf{H} \mid d(z, z_0) \leq d(z, \gamma z_0) \text{ for all } \gamma \in \Gamma\},$$

$$(1.6.2) \quad U = \bigcap_{\gamma \in \Gamma - Z(\Gamma)} U_\gamma$$

$$= \{z \in \mathbf{H} \mid d(z, z_0) < d(z, \gamma z_0) \text{ for all } \gamma \in \Gamma - Z(\Gamma)\}.$$

Let us show that F is a fundamental domain of Γ . First we are going to show that F satisfies condition (i) of the definition of the fundamental domain. Let z_1 be any point of \mathbf{H} . Since Γ is a Fuchsian group, $\{\gamma z_0 \mid \gamma \in \Gamma\}$ has no accumulation point in \mathbf{H} . Hence there exists the minimum in $\{d(z_1, \gamma z_0) \mid \gamma \in \Gamma\}$, which we denote by $d(z_1, \gamma_0 z_0)$ with some $\gamma_0 \in \Gamma$. Since $d(z_1, \gamma_0 z_0) \leq d(z_1, \gamma z_0)$ for any $\gamma \in \Gamma$, we have $z_1 \in \gamma_0 F$. Next let us show that U is open and $F = \bar{U}$. Take an open neighborhood V_z for each point $z \in \mathbf{H}$ so that \bar{V}_z is compact. Then

$$U = \bigcup_{z \in \mathbf{H}} \bigcap_{\gamma \in \Gamma - Z(\Gamma)} (U_\gamma \cap V_z).$$

We easily see that if $U_\gamma \cap V_z \neq \emptyset$, then $U_\gamma \cap V_z = V_z$ or $C_\gamma \cap V_z \neq \emptyset$. Therefore it follows from Lemma 1.6.1 that $\bigcap_{\gamma \in \Gamma - Z(\Gamma)} (U_\gamma \cap V_z)$ is an intersection of finitely many open subsets. Therefore it is an open set, so that U is open. By a similar argument, we have that

$$\begin{aligned} F &= \bigcup_{z \in \mathbf{H}} \bigcap_{\gamma \in \Gamma - Z(\Gamma)} (F_\gamma \cap \bar{V}_z) \\ &= \overline{\bigcup_{z \in \mathbf{H}} \bigcap_{\gamma \in \Gamma - Z(\Gamma)} (U_\gamma \cap V_z)} \subset \bar{U}. \end{aligned}$$

Since obviously $F \supset \bar{U}$, we get $F = \bar{U}$. Lastly let us verify condition (iii). Let $\gamma \in \Gamma - Z(\Gamma)$. Suppose that $U \cap \gamma U \neq \emptyset$ and $z_1 \in U \cap \gamma U$. Since $z_1 \in U$, we see that

$$d(z_1, z_0) < d(z_1, \gamma z_0) = d(\gamma^{-1} z_1, z_0).$$

On the other hand, since $z_1 \in \gamma U$, we see that

$$d(\gamma^{-1} z_1, z_0) < d(\gamma^{-1} z_1, \gamma^{-1} z_0) = d(z_1, z_0).$$

This is a contradiction, and therefore we get $U \cap \gamma U = \emptyset$ for $\gamma \in \Gamma - Z(\Gamma)$.

Thus we have proved that F is a fundamental domain of Γ , which is the first part of the following

Theorem 1.6.2. *The subset F of \mathbf{H} defined by (1.6.1) is a fundamental domain of Γ . Moreover, under the same notation as above, F has the following properties:*

- (1) any geodesic joining two points of F is contained in F ;
- (2) put $L_\gamma = F \cap \gamma F$ for $\gamma \in \Gamma - Z(\Gamma)$. Then $L_\gamma \subset C_\gamma$. If $L_\gamma \neq \emptyset$, then L_γ is only one point or a geodesic;
- (3) for any compact subset M of \mathbf{H} , $\{\gamma \in \Gamma \mid M \cap \gamma F \neq \emptyset\}$ is finite.

Proof. (1): Since C_γ is a geodesic, it is obvious that any geodesic joining two points of F_γ is contained in F_γ . Thus we get (1) since $F = \bigcap_\gamma F_\gamma$. (2): Let $z \in L_\gamma$. Then

$$d(z, z_0) \leq d(z, \gamma z_0) = d(\gamma^{-1} z, z_0) \leq d(\gamma^{-1} z, \gamma^{-1} z_0) = d(z, z_0).$$

Thus $z \in C_\gamma$. The latter half of (2) follows from (1). (3): We may assume that M is connected. Since

$$\#\{\gamma \in \Gamma \mid M \cap \gamma F \neq \emptyset\} = \#\{\gamma \in \Gamma \mid \gamma_0 M \cap \gamma F \neq \emptyset\}$$

for any $\gamma_0 \in \Gamma$, we may assume $M \cap F \neq \emptyset$ by taking $\gamma_0 M$ in place of M , if necessary. Assume $M \cap \delta F \neq \emptyset$ for $\delta \in \Gamma - Z(\Gamma)$, then $M \cap C_\delta \neq \emptyset$. In fact, since $F = \bigcap_\gamma F_\gamma$, we see that $M \cap F_\delta \neq \emptyset$ and $M \cap \delta F_{\delta^{-1}} \neq \emptyset$. By definition, we see that $F_\delta = U_\delta \cup C_\delta$, $\delta F_{\delta^{-1}} = \delta U_{\delta^{-1}} \cup C_\delta$, and $H = U_\delta \cup \delta U_{\delta^{-1}} \cup C_\delta$ (disjoint union). If $M \subset U_\delta \cup \delta U_{\delta^{-1}}$, then $M \subset U_\delta$ or $M \subset \delta U_{\delta^{-1}}$, because M is connected. This contradicts the fact that $M \cap F_\delta \neq \emptyset$ and $M \cap \delta F_{\delta^{-1}} \neq \emptyset$. Then we obtain $M \cap C_\delta \neq \emptyset$. Therefore (3) follows from Lemma 1.6.1. \square

For each $\gamma \in \Gamma - Z(\Gamma)$, we put $L_\gamma = F \cap \gamma F$. We call L_γ a *side* of F if L_γ is neither a null set nor a point. The boundary of F consists of sides of F . For two distinct sides L and L' of F , $L \cap L'$ is either a null set or a point. When $L \cap L'$ is a point z , we call z a *vertex* of F in H and the angle between L and L' the *interior angle* of F at z . It follows from Theorem 1.6.2(1) that any interior angle of F is less than π . For two sides L, L' of F , we say that L and L' are *linked* and write $L \sim L'$ if either $L = L'$ or there exist distinct sides L_1, L_2, \dots, L_n of F such that

$$L = L_1, \quad L' = L_n \quad \text{and} \quad L_v \cap L_{v+1} \neq \emptyset \quad (1 \leq v < n).$$

For a side L of F , the connected component of the boundary containing L is a union of all sides L' which are linked to L . When a side L of F has no end, we call the intersection points of the extension of L and $\mathbb{R} \cup \{\infty\}$ the *vertices of F on $\mathbb{R} \cup \{\infty\}$* or the *ends of L on $\mathbb{R} \cup \{\infty\}$* . Here the extension is taken by considering L a part of a circle or a line orthogonal to the real axis. The following lemma will be used in §1.9.

Lemma 1.6.3. *Let F be a fundamental domain of Γ defined by (1.6.1). If a vertex x of F on $\mathbb{R} \cup \{\infty\}$ is an end of two distinct sides and x is fixed by a non-scalar element γ of Γ , then x is a cusp of Γ .*

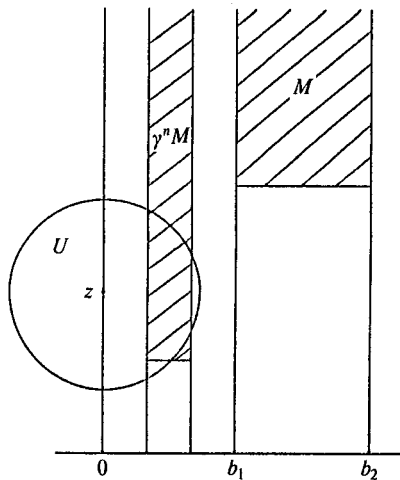

Fig. 1.6.2

Proof. By assumption, γ is either parabolic or hyperbolic. Assume that γ is hyperbolic. We may assume by Lemma 1.3.2(2) that $x = \infty$ and γ has another fixed point 0. Then we see $\gamma = \begin{bmatrix} a & 0 \\ 0 & d \end{bmatrix}$ ($a, d \in \mathbb{R}^\times$, $a \neq d$) and we may assume that $a/d < 1$ by taking γ^{-1} in place of γ , if necessary. Since sides of F are geodesics, two sides which have the end ∞ are on the lines $\operatorname{Re}(z) = b_1$, $\operatorname{Re}(z) = b_2$ with real numbers b_1, b_2 ($b_1 < b_2$). Put

$$M = \{z \in \mathbf{H} \mid \operatorname{Im}(z) \geq c, \quad b_1 \leq \operatorname{Re}(z) \leq b_2\}.$$

Then $M \subset F$ if c is sufficiently large. Take $z \in \mathbf{H}$ on the imaginary axis and a neighborhood U of z such that \bar{U} is compact. Then there exist infinitely many integers n such that $U \cap \gamma^n F \supset U \cap \gamma^n M \neq \emptyset$. This contradicts Theorem 1.6.2(3). \square

§ 1.7. Quotient Spaces $\Gamma \backslash \mathbf{H}^*$

Suppose that a group G acts on a topological space X . We begin by giving sufficient conditions under which the quotient space $G \backslash X$ becomes a Hausdorff space.

Lemma 1.7.1. *Assume that for any two points x, y of X , there exist neighborhoods U of x and V of y such that $gU \cap V = \emptyset$ for all $g \in G$ satisfying $gx \neq y$. Then $G \backslash X$ is a Hausdorff space.*

Proof. Let π be the canonical mapping of X onto $G \backslash X$. From the definition of the quotient topology, $\pi(U)$ and $\pi(V)$ are neighborhoods of $\pi(x)$ and $\pi(y)$, respectively. We see that $\pi(U) \cap \pi(V) \neq \emptyset$ if and only if there exists $g \in G$ such that $gU \cap V \neq \emptyset$. By assumption, the latter is equivalent to saying that there exists $g \in G$ such that $gx = y$, namely, $\pi(x) = \pi(y)$. This implies that $G \backslash X$ is a Hausdorff space. \square

Lemma 1.7.2. *If a group Γ acts properly discontinuously on a Hausdorff space X , then $\Gamma \backslash X$ is also a Hausdorff space.*

Proof. Let x, y be any two points of X . By assumption, there exist neighborhoods U_0 of x and V_0 of y such that $\#\{\gamma \in \Gamma \mid \gamma U_0 \cap V_0 \neq \emptyset\} < \infty$. Put

$$\{\gamma \in \Gamma \mid \gamma U_0 \cap V_0 \neq \emptyset\} = \{\gamma_1, \gamma_2, \dots, \gamma_m\}.$$

Renumbering the indices, we may assume that

$$\gamma_k x = y \quad (1 \leq k \leq l), \quad \gamma_k x \neq y \quad (l+1 \leq k \leq m).$$

We can take neighborhoods W_k of $\gamma_k x$ and V_k of y for $k > l$ such that $W_k \cap V_k = \emptyset$. Put

$$U = U_0 \cap \bigcap_{k=l+1}^m \gamma_k^{-1} W_k, \quad V = V_0 \cap \bigcap_{k=l+1}^m V_k.$$

Then U and V are neighborhoods of x and y , respectively, and we see that

$$\gamma U \cap V \neq \emptyset \Leftrightarrow \gamma \in \{\gamma_1, \dots, \gamma_l\} \Leftrightarrow \gamma x = y.$$

Therefore Lemma 1.7.1 implies that $\Gamma \backslash X$ is a Hausdorff space. □

In particular, the quotient space $\Gamma \backslash \mathbf{H}$ of a Fuchsian group Γ is a Hausdorff space. If $\Gamma \backslash \mathbf{H}$ is compact or has a suitable compactification, then we can apply the theory of compact Riemann surfaces to study $\Gamma \backslash \mathbf{H}$. We begin by adding cusps of Γ to \mathbf{H} to compactify $\Gamma \backslash \mathbf{H}$.

Let P_Γ be the set of all cusps of Γ and put

$$(1.7.1) \quad \mathbf{H}^* = \mathbf{H}_\Gamma^* = \mathbf{H} \cup P_\Gamma.$$

When Γ has no cusps, $P_\Gamma = \emptyset$ and $\mathbf{H}^* = \mathbf{H}$. We put

$$(1.7.2) \quad U_l = \{z \in \mathbf{H} \mid \text{Im}(z) > l\}, \quad U_l^* = U_l \cup \{\infty\}, \quad l > 0.$$

Now we define the topology on \mathbf{H}^* as follows:

(i) for $z \in \mathbf{H}$, we take as the fundamental neighborhood system at z in \mathbf{H}^* that at z in \mathbf{H} ;

(ii) for $x \in P_\Gamma$, we take as the fundamental neighborhood system at x the family $\{\sigma^{-1} U_l^* \mid l > 0\}$, where $\sigma \in SL_2(\mathbb{R})$ such that $\sigma x = \infty$.

Then \mathbf{H}^* is also a Hausdorff space under this topology. In fact, put $\sigma = \begin{bmatrix} a & b \\ c & d \end{bmatrix}$ and $x = -d/c$. Then we see that

$$\sigma^{-1} U_l = \{z \in \mathbf{H} \mid \text{Im}(z) / |cz + d|^2 > l\}$$

and this is the inside of a circle with the radius $(2lc^2)^{-1}$ tangent to the real axis at x . For $x \in P_\Gamma$, we call $\sigma^{-1} U_l$ a neighborhood of x in \mathbf{H} . Since the action of Γ on \mathbf{H} is a conformal mapping which maps circles or lines to those, Γ also acts on the topological space \mathbf{H}^* . Therefore the quotient space $\Gamma \backslash \mathbf{H}^*$ can be defined and we may regard $\Gamma \backslash \mathbf{H}$ naturally as a subspace of $\Gamma \backslash \mathbf{H}^*$. When Γ has no cusps, we have $\Gamma \backslash \mathbf{H}^* = \Gamma \backslash \mathbf{H}$.

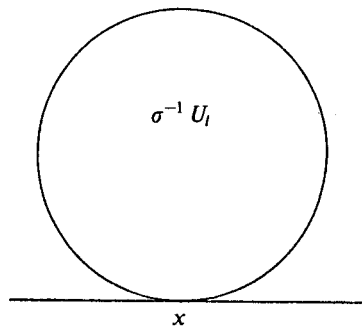

Fig. 1.7.1

Now let us show that $\Gamma \setminus \mathbf{H}^*$ is also a Hausdorff space.

Lemma 1.7.3. *Assume that ∞ is a cusp of Γ and put*

$$\Gamma_\infty \cdot \{\pm 1\} = \left\{ \pm \begin{bmatrix} 1 & h \\ 0 & 1 \end{bmatrix}^m \mid m \in \mathbb{Z} \right\}.$$

Let $\gamma = \begin{bmatrix} a & b \\ c & d \end{bmatrix} \in \Gamma$. If $|ch| < 1$, then $\gamma \in \Gamma_\infty$.

Proof. Assume that $|ch| < 1$. We define inductively $\gamma_n \in \Gamma \cdot \{\pm 1\}$ by

$$\gamma_0 = \gamma, \quad \gamma_{n+1} = \gamma_n \begin{bmatrix} 1 & h \\ 0 & 1 \end{bmatrix} \gamma_n^{-1}.$$

We write

$$\gamma_n = \begin{bmatrix} a_n & b_n \\ c_n & d_n \end{bmatrix},$$

then we see that

$$\begin{aligned} a_{n+1} &= 1 - a_n(c_n h), & b_{n+1} &= a_n^2 h, \\ c_{n+1} &= -c_n^2 h, & d_{n+1} &= 1 + a_n(c_n h). \end{aligned}$$

Hence we get that

$$c_n = -c(ch)^{2^n - 1}, \quad |a_n| \leq |a| + n, \quad (n > 0),$$

and

$$|a_{n+1} - 1| = |d_{n+1} - 1| = |a_n| |c_n h| \leq (|a| + n) |ch|^{2^n}.$$

Therefore γ_n converges to $\begin{bmatrix} 1 & h \\ 0 & 1 \end{bmatrix}$. Since Γ is discrete, there exists n such that $\gamma_n = \begin{bmatrix} 1 & h \\ 0 & 1 \end{bmatrix}$. This implies $c = 0$. \square

Lemma 1.7.4. *Let x_1, x_2 be two cusps of Γ , and σ_1, σ_2 elements of $SL_2(\mathbb{R})$ such that $\sigma_1 x_1 = \sigma_2 x_2 = \infty$. Put*

$$\sigma_i \Gamma_{x_i} \sigma_i^{-1} \cdot \{\pm 1\} = \left\{ \pm \begin{bmatrix} 1 & h_i \\ 0 & 1 \end{bmatrix}^m \mid m \in \mathbb{Z} \right\} \quad (i = 1, 2).$$

Take two positive numbers l_1 and l_2 satisfying $l_1 l_2 > |h_1 h_2|$. Then for $\gamma \in \Gamma$,

$$\gamma \sigma_1^{-1} U_{l_1} \cap \sigma_2^{-1} U_{l_2} = \emptyset \quad \text{if} \quad \gamma x_1 \neq x_2.$$

Proof. By taking $\sigma_1 \Gamma \sigma_1^{-1}$ and $\sigma_1 \gamma \sigma_1^{-1}$ in place of Γ and σ , we may assume $x_1 = \infty$ and $\sigma_1 = 1$. Assume that $\gamma U_{l_1} \cap \sigma_2^{-1} U_{l_2} \neq \emptyset$. Put $\delta = \sigma_2 \gamma$ and write

$\delta^{-1} = \begin{bmatrix} a & b \\ c & d \end{bmatrix}$. Since $\delta U_{l_1} \cap U_{l_2} \neq \emptyset$, we see that

$$l_1 l_2 < \text{Im}(\delta^{-1} z) \text{Im}(z) = \text{Im}(z)^2 / |cz + d|^2 \leq c^{-2},$$

where $z \in \delta U_{l_1} \cap U_{l_2}$. Put $\gamma_1 = \begin{bmatrix} 1 & h_1 \\ 0 & 1 \end{bmatrix} \in \Gamma_\infty \cdot \{\pm 1\}$. Then we see

$$\delta \gamma_1 \delta^{-1} = \sigma_2 \gamma \gamma_1 \gamma^{-1} \sigma_2^{-1} \in \sigma_2 \Gamma \sigma_2^{-1} \cdot \{\pm 1\}.$$

Put

$$\delta \gamma_1 \delta^{-1} = \begin{bmatrix} a_1 & b_1 \\ c_1 & d_1 \end{bmatrix},$$

then $c_1 = -c^2 h_1$ and

$$|c_1 h_2| = |c^2 h_1 h_2| < c^2 l_1 l_2 \leq 1.$$

Applying Lemma 1.7.3 to $\sigma_2 \Gamma \sigma_2^{-1}$ and $\delta \gamma_1 \delta^{-1}$, we obtain $c = c_1 = 0$. This implies $\gamma \infty = \sigma_2^{-1} \delta \infty = \sigma_2^{-1} \infty = x_2$. \square

In particular, we obtain by taking $x_1 = x_2$ the following

Corollary 1.7.5. *Let x be a cusp of Γ , and σ an element of $SL_2(\mathbb{R})$ such that $\sigma x = \infty$. Put $\sigma \Gamma_x \sigma^{-1} \cdot \{\pm 1\} = \left\{ \pm \begin{bmatrix} 1 & h \\ 0 & 1 \end{bmatrix}^m \mid m \in \mathbb{Z} \right\}$ with $h > 0$. If $l > h$, then for $\gamma \in \Gamma$,*

$$\gamma \sigma^{-1} U_l \cap \sigma^{-1} U_l = \emptyset \quad \text{if } \gamma \notin \Gamma_x.$$

Lemma 1.7.6. *Let x be a cusp of Γ , and $\sigma \in SL_2(\mathbb{R})$ such that $\sigma x = \infty$. For any compact subset M of \mathbf{H} , there exists a positive number l such that*

$$M \cap \gamma \sigma^{-1} U_l = \emptyset$$

for any $\gamma \in \Gamma$.

Proof. Taking $\sigma \Gamma \sigma^{-1}$ and σM in place of Γ and M , we may assume that $x = \infty$, $\sigma = 1$. Put $\Gamma_\infty \cdot \{\pm 1\} = \left\{ \pm \begin{bmatrix} 1 & h \\ 0 & 1 \end{bmatrix}^m \mid m \in \mathbb{Z} \right\}$. If $\gamma \in \Gamma_\infty$, then $\gamma U_l = U_l$; otherwise $\gamma U_l \subset \{z \in \mathbf{H} \mid \text{Im}(z) < h^2/l\}$ by Lemma 1.7.3. Therefore it is sufficient to take l so that $M \subset \{z \in \mathbf{H} \mid h^2/l < \text{Im}(z) < l\}$.

Lemma 1.7.7. *$\Gamma \backslash \mathbf{H}^*$ is a Hausdorff space.*

Proof. We have only to verify the condition in Lemma 1.7.1 for $G = \Gamma$ and $X = \mathbf{H}^*$. In fact, Lemmas 1.7.2, 1.7.6 and 1.7.4 imply this in the cases (i) $x, y \in \mathbf{H}$, (ii) $x \in \mathbf{H}, y \in P_\Gamma$ and (iii) $x, y \in P_\Gamma$, respectively. \square

We denote by π or π_Γ the natural mapping of \mathbf{H}^* onto $\Gamma \backslash \mathbf{H}^*$. We call $\mathfrak{a} = \pi(z) \in \Gamma \backslash \mathbf{H}^*$ ($z \in \mathbf{H}^*$) an *elliptic point* or a *cusp* if z is so. When \mathfrak{a} is neither an elliptic point nor a cusp, we call \mathfrak{a} an *ordinary point*.

Theorem 1.7.8. *If $\Gamma \backslash \mathbf{H}^*$ is compact, then the numbers of the elliptic points and the cusps of $\Gamma \backslash \mathbf{H}^*$ are finite.*

Proof. Let $\mathfrak{a} = \pi(z)$ be any point of $\Gamma \backslash \mathbf{H}^*$. As was shown in the proof of Lemma 1.7.7, we can take a neighborhood U of z so that for $\gamma \in \Gamma$, $\gamma U \cap U \neq \emptyset$ if

and only if $\gamma z = z$. Then $\pi(U) - \{a\}$ contains neither elliptic points nor cusps. Since $\pi(U)$ is open in $\Gamma \backslash \mathbf{H}^*$ and $\Gamma \backslash \mathbf{H}^*$ is compact, $\Gamma \backslash \mathbf{H}^*$ can be covered with finitely many $\pi(U)$. Thus $\Gamma \backslash \mathbf{H}^*$ has only finite elliptic points and cusps. \square

We call Γ a *Fuchsian group of the first kind* if $\Gamma \backslash \mathbf{H}^*$ is compact. Such groups are our main objects.

§1.8. The Structure of $\Gamma \backslash \mathbf{H}^*$ as a Riemann Surface

Complex manifolds of dimension 1 are called *Riemann surfaces*. We are going to construct a structure of a Riemann surface on $\Gamma \backslash \mathbf{H}^*$.

We begin by recalling the definition of Riemann surfaces. Let \mathfrak{R} be a connected topological space. A pair (V_α, t_α) of an open subset V_α of \mathfrak{R} and a homeomorphism t_α of V_α onto a connected complex domain is called a *local chart*. A collection $\{(V_\alpha, t_\alpha)\}$ is called a (complex) *coordinate system* of \mathfrak{R} if it satisfies the following conditions:

- (i) $\mathfrak{R} = \bigcup_\alpha V_\alpha$;
- (ii) if $V_\alpha \cap V_\beta \neq \emptyset$, then $t_\beta t_\alpha^{-1}$ is a holomorphic mapping of $t_\alpha(V_\alpha \cap V_\beta)$ onto $t_\beta(V_\alpha \cap V_\beta)$.

We call V_α a *coordinate neighborhood*, and t_α a *local coordinate on V_α* . Take another coordinate system $\{(V'_\beta, t'_\beta)\}$ of \mathfrak{R} . We say that $\{(V_\alpha, t_\alpha)\}$ and $\{(V'_\beta, t'_\beta)\}$ are equivalent if $\{(V_\alpha, t_\alpha)\} \cup \{(V'_\beta, t'_\beta)\}$ is also a coordinate system of \mathfrak{R} . We call \mathfrak{R} a *Riemann surface* if an equivalent class of coordinate systems of \mathfrak{R} is given.

Example 1.8.1. The Riemann sphere $\mathbb{P} = \mathbb{C} \cup \{\infty\}$ is a Riemann surface. In fact, let $V_1 = \mathbb{C}$, $t_1(z) = z$; $V_2 = \mathbb{P} - \{0\}$, $t_2(z) = 1/z$. Then $\{(V_i, t_i) \mid i = 1, 2\}$ is a coordinate system of \mathbb{P} . Any connected domain of \mathbb{C} is also a Riemann surface.

Let us now define a structure of a Riemann surface on the quotient space $\Gamma \backslash \mathbf{H}^*$ for a Fuchsian group Γ . Let $a = \pi(z_0) \in \Gamma \backslash \mathbf{H}^*$ ($z_0 \in \mathbf{H}^*$).

1° First assume that a is an ordinary point. From the proof of Lemma 1.7.2, we can take a neighborhood U of z_0 so that $U \subset \mathbf{H}$ and

$$(1.8.1) \quad \gamma U \cap U \neq \emptyset \Leftrightarrow \gamma \in Z(\Gamma).$$

Put $V_a = \pi(U)$. Then V_a is a neighborhood of a and U is homeomorphic to V_a by π . Let t_a be the inverse mapping of π ; namely,

$$t_a: V_a \rightarrow U \quad \text{and} \quad t_a \circ \pi(z) = z \quad \text{for} \quad z \in U.$$

2° Next let a be an elliptic point. Take $\rho \in SL_2(\mathbb{C})$ so that $\rho z_0 = 0$ and $\rho \mathbf{H} = \mathbf{K}$. Put $W_r = \{z \in \mathbb{C} \mid |z| < r\}$ for $r > 0$ and $U = \rho^{-1}(W_r)$. Since z_0 is an elliptic point, Γ_{z_0} is a finite cyclic group by Theorem 1.5.4(1), and so is $\rho \Gamma_{z_0} \rho^{-1}$. Thus by Schwarz's theorem, the action of an element of $\rho \Gamma_{z_0} \rho^{-1}$ on \mathbf{K} is a rotation around 0 of angle $2\pi n/e$ with $n \in \mathbb{Z}$ and $e = |\Gamma_{z_0}/Z(\Gamma)|$ (see also the proof of Theorem 1.1.3). Hence U is stable under the action of Γ_{z_0} . From the proof of Lemma 1.7.2, we can

take r so small that

$$(1.8.2) \quad \gamma U \cap U \neq \emptyset \Leftrightarrow \gamma \in \Gamma_{z_0}.$$

Then $\pi(U)$ is homeomorphic to $\Gamma_{z_0} \backslash U$, which is homeomorphic to $\rho \Gamma_{z_0} \rho^{-1} \backslash W_r$. We define a function ϕ on W_r by

$$\phi(w) = w^e \quad (e = |\Gamma_{z_0}/Z(\Gamma)|).$$

Since ϕ is invariant under rotation of angle $2\pi/e$ with center 0, it induces the homeomorphism ϕ_1 of $\rho \Gamma_{z_0} \rho^{-1} \backslash W_r$ onto W_{r^e} . Therefore the following diagram is commutative and all horizontal arrows are homeomorphisms:

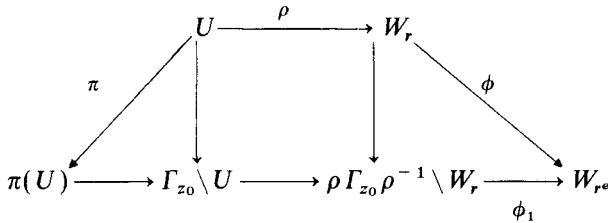

We put $V_a = \pi(U)$ and define the local coordinate t_a by the homeomorphism of V_a onto W_{r^e} given in the above diagram; namely,

$$t_a \circ \pi(z) = (\rho z)^e \quad (z \in U).$$

3° Lastly take a cusp a . Let σ be an element of $SL_2(\mathbb{R})$ such that $\sigma z_0 = \infty$. Put $U = \sigma^{-1} U_l$, $U^* = \sigma^{-1} U_l^*$, where U_l and U_l^* are as in (1.7.2). If l is sufficiently large, then we see by Corollary 1.7.5 that

$$\gamma U^* \cap U^* \neq \emptyset \Leftrightarrow \gamma \in \Gamma_{z_0}.$$

Similar to 2°, V_a is homeomorphic to $\Gamma_{z_0} \backslash U^*$ which is homeomorphic to $\sigma \Gamma_{z_0} \sigma^{-1} \backslash U_l^*$. Put $\sigma \Gamma_{z_0} \sigma^{-1} \cdot \{\pm 1\} = \left\{ \pm \begin{bmatrix} 1 & h \\ 0 & 1 \end{bmatrix}^m \mid m \in \mathbb{Z} \right\}$ with $h > 0$, and define the function ψ on U_l^* by

$$\psi(z) = \begin{cases} e^{2\pi iz/h} & \text{for } z \in U_l, \\ 0 & \text{for } z = \infty. \end{cases}$$

Then ψ is an open continuous mapping by the definition of the topology of \mathbf{H}^* . Since ψ is invariant under $\sigma \Gamma_{z_0} \sigma^{-1}$, ψ induces a mapping ψ_1 of $\sigma \Gamma_{z_0} \sigma^{-1} \backslash U_l^*$ onto W_r with $r = e^{-2\pi l/h}$, where W_r is as in 2°. Since ψ_1 is injective and ψ is open and continuous, ψ_1 is the homeomorphism of $\sigma \Gamma_{z_0} \sigma^{-1} \backslash U_l^*$ onto W_r . Therefore if we put $V_a = \pi(U^*)$, we obtain the following commutative diagram:

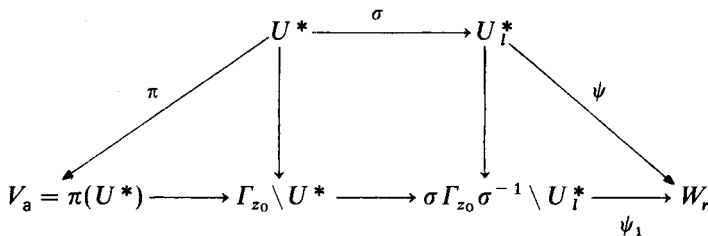

We define t_a as the homeomorphism of V_a onto W_r in the above diagram; namely,

$$t_a \circ \pi(z) = \begin{cases} e^{2\pi i \sigma z/h} & \text{for } z \in U, \\ 0 & \text{for } z = z_0. \end{cases}$$

We can easily verify that $\{(V_a, t_a)\}$ given above is a coordinate system of $\Gamma \backslash \mathbf{H}^*$, and defines on $\Gamma \backslash \mathbf{H}^*$ a structure of a Riemann surface. We denote by \mathfrak{R}_Γ the Riemann surface $\Gamma \backslash \mathbf{H}^*$. For $\mathfrak{a} = \pi(z_0) \in \mathfrak{R}_\Gamma$, we put

$$(1.8.3) \quad e_a = |\Gamma_{z_0}/Z(\Gamma)|,$$

and call it the *ramification index* of \mathfrak{a} , which is independent of the choice of a representative element z_0 . We note that $e_a = 1$ implies \mathfrak{a} is an ordinary point and that $e_a = \infty$ implies \mathfrak{a} is a cusp.

Theorem 1.8.1. *If $\Gamma \backslash \mathbf{H}$ is compact, then Γ has no cusps.*

Proof. Assume that Γ has a cusp x . Put $\mathfrak{a} = \pi(x) \in \Gamma \backslash \mathbf{H}^*$. Then from the above consideration, we can take a neighborhood V_a of \mathfrak{a} so that $\bar{V}_a \cap (\Gamma \backslash \mathbf{H}) = \bar{V}_a - \{\mathfrak{a}\} \simeq \{z \in \mathbb{C} | 0 < |z| \leq r\}$ for some $r > 0$, where \bar{V}_a denotes the closure of V_a in $\Gamma \backslash \mathbf{H}^*$. Since $\bar{V}_a \cap (\Gamma \backslash \mathbf{H})$ is a closed subset of $\Gamma \backslash \mathbf{H}$, it is compact; this contradicts that $\{z \in \mathbb{C} | 0 < |z| \leq r\}$ is not compact. Therefore Γ has no cusps. \square

If Γ is a Fuchsian group of the first kind (this is the case we shall discuss in Chapter 2 and onwards), \mathfrak{R}_Γ is a compact Riemann surface. In the following, we recall some results on compact Riemann surfaces which we need afterwards. See, for example, [Lang] for proofs.

Let \mathfrak{R} be a compact Riemann surface and $\{(V_\alpha, t_\alpha)\}$ a coordinate system of \mathfrak{R} . Let ϕ be a function defined on V_α and $\mathfrak{a} \in V_\alpha$. We say that ϕ is *holomorphic* (resp. *meromorphic*) at \mathfrak{a} if $\phi \circ t_\alpha^{-1}$ is holomorphic (resp. meromorphic) at $t_\alpha(\mathfrak{a})$. We also say that ϕ has a *pole* or a *zero* at \mathfrak{a} if so does $\phi \circ t_\alpha^{-1}$ at $t_\alpha(\mathfrak{a})$. If ϕ is meromorphic at \mathfrak{a} , then it has a Laurent expansion of the form

$$\phi \circ t_\alpha^{-1}(z) = \sum_{n=1}^{\infty} a_n(z - t_\alpha(\mathfrak{a}))^n \quad (a_l \neq 0)$$

on a neighborhood of $t_\alpha(\mathfrak{a})$. We write

$$(1.8.4) \quad v_a(\phi) = l,$$

and call it the *order* of ϕ at \mathfrak{a} . We note that these definitions are independent of the choice of coordinates t_α . We say that a function ϕ on \mathfrak{R} is *holomorphic* (resp. *meromorphic*) if it is holomorphic (resp. meromorphic) at any point of \mathfrak{R} . We denote by $K(\mathfrak{R})$ the field consisting of all meromorphic functions on \mathfrak{R} . Since \mathfrak{R} is compact, any holomorphic function on \mathfrak{R} must be constant by the maximum principle and $K(\mathfrak{R})$ is an algebraic function field of one variable. We simply call $K(\mathfrak{R})$ the *function field* of \mathfrak{R} . For a non-constant function ϕ of $K(\mathfrak{R})$, the numbers of zeros and poles are finite and we put

$$(1.8.5) \quad n_0(\phi) = \sum_{v(\phi) > 0} v_a(\phi), \quad n_\infty(\phi) = \sum_{v(\phi) < 0} |v_a(\phi)|.$$

It is known that

$$(1.8.6) \quad [K(\mathfrak{R}):\mathbb{C}(\phi)] = n_o(\phi) = n_\infty(\phi).$$

Let $\mathfrak{R}, \mathfrak{R}'$ be two compact Riemann surfaces and F a mapping of \mathfrak{R}' into \mathfrak{R} . Take coordinate systems $\{(V_\alpha, t_\alpha)\}$ and $\{(V'_\beta, t'_\beta)\}$ of \mathfrak{R} and \mathfrak{R}' , respectively. We say that F is *complex analytic* if $t_\alpha \circ F \circ t'^{-1}_\beta$ is holomorphic on $t'_\beta(V'_\beta \cap F^{-1}(V_\alpha))$ providing $F(V'_\beta) \cap V_\alpha \neq \emptyset$. In particular, meromorphic functions on \mathfrak{R} are no other than complex analytic mappings of \mathfrak{R} into the Riemann sphere \mathbb{P} . Let F be a complex analytic mapping of \mathfrak{R}' into \mathfrak{R} . Assume that the image of F is not one point. Then it is open. Since \mathfrak{R}' is compact, it is also closed. Therefore we get $F(\mathfrak{R}') = \mathfrak{R}$, since \mathfrak{R} is connected. Under this situation, we call (\mathfrak{R}', F) or simply \mathfrak{R}' the *covering of \mathfrak{R}* . Moreover we define, for $\mathbf{b} \in \mathfrak{R}'$,

$$e_{\mathbf{b}, F} = v_{\mathbf{b}}(t_\alpha \circ F)$$

providing $F(\mathbf{b}) \in V_\alpha$, and call it the *ramification index of (\mathfrak{R}', F) at \mathbf{b}* or simply the *ramification index of \mathbf{b}* . Since \mathfrak{R}' is compact, the number of points \mathbf{b} of \mathfrak{R}' such that $e_{\mathbf{b}, F} \neq 1$ is finite. Let $F^{-1}(\mathbf{a}) = \{\mathbf{b}_1, \dots, \mathbf{b}_l\}$ for $\mathbf{a} \in \mathfrak{R}$, then the integer

$$n = \sum_{i=1}^l e_{\mathbf{b}_i, F}$$

is independent of the choice of \mathbf{a} . We call n the *degree of the covering (\mathfrak{R}', F)* . We see $\phi \circ F \in K(\mathfrak{R}')$ for $\phi \in K(\mathfrak{R})$. This correspondence " $\phi \mapsto \phi \circ F$ " is an isomorphism of $K(\mathfrak{R})$ into $K(\mathfrak{R}')$. Write $K(\mathfrak{R}) \circ F = \{\phi \circ F \mid \phi \in K(\mathfrak{R})\}$; then it is known that

$$(1.8.7) \quad [K(\mathfrak{R}'):K(\mathfrak{R}) \circ F] = n.$$

The equality (1.8.6) is a special case of (1.8.7).

Lastly let χ be the Euler–Poincaré characteristic of \mathfrak{R} . We define the *genus g of \mathfrak{R}* by

$$\chi = 2 - 2g.$$

Then g is a non-negative integer. If (\mathfrak{R}', F) is a covering of \mathfrak{R} and g' is the genus of \mathfrak{R}' , then the following relation (the *Hurwitz formula*) holds:

$$(1.8.8) \quad 2g' - 2 = n(2g - 2) + \sum_{\mathbf{b} \in \mathfrak{R}'} (e_{\mathbf{b}, F} - 1),$$

where n is the degree of the covering (\mathfrak{R}', F) .

§ 1.9. Fuchsian Groups of the First Kind

Let Γ be a Fuchsian group. For a while we do not assume that Γ is of the first kind. We are going to define a measure on the quotient space $\Gamma \backslash \mathbf{H}^*$ induced from the measure dv on \mathbf{H} defined by (1.4.2). Let X be a locally compact space, and $C_c(X)$ the space of the continuous functions on X with compact support. For any linear functional M on $C_c(X)$ satisfying $M(\phi) \geq 0$ if $\phi \geq 0$, there exists a measure $d\mu$ on

X such that

$$M(\phi) = \int_X \phi d\mu.$$

We are going to construct such a linear functional on $C_c(\Gamma \backslash \mathbf{H}^*)$. In the following, we use the same notations as in the previous section. Let $\phi \in C_c(\Gamma \backslash \mathbf{H}^*)$. Using the partition of unity, we may assume that the support of ϕ is contained in the neighborhood V_a ($a \in \Gamma \backslash \mathbf{H}^*$).

1° Assume that a is either an ordinary point or an elliptic point. Let z_0 be a point of \mathbf{H} such that $\pi(z_0) = a$, and U a neighborhood of z_0 such that $\pi(U) = V_a$. Since $\phi \circ \pi$ is a continuous function with compact support on \mathbf{H} , we can define

$$M(\phi) = \frac{1}{e_a} \int_U \phi \circ \pi(z) \frac{dx dy}{y^2} \quad (< \infty),$$

where e_a is the ramification index of a . This definition is obviously independent of the choice of z_0 .

2° Let a be a cusp, $x_0 \in \mathbb{R} \cup \{\infty\}$ a point such that $\pi(x_0) = a$, and σ an element of $SL_2(\mathbb{R})$ such that $\sigma x_0 = \infty$. Moreover let $U^* = \sigma^{-1} U_i^*$ be a neighborhood of x_0 such that $\pi(U^*) = V_a$. Put $U_i^* = \{z \in \mathbf{H} \mid |\operatorname{Im}(z)| \geq l, 0 \leq \operatorname{Re}(z) \leq h\}$, then $\phi \circ \pi$ is continuous on U_i^* . We put

$$M(\phi) = \int_{\sigma^{-1} U_i^*} \phi \circ \pi(z) \frac{dx dy}{y^2}.$$

To see that $M(\phi)$ is finite, we have only to prove $\int_{\sigma^{-1} U_i^*} \frac{dx dy}{y^2}$ is finite, since $\phi \circ \pi$ is bounded on $\sigma^{-1} U_i^*$. Since $y^{-2} dx dy$ is invariant under the action of $SL_2(\mathbb{R})$, we have

$$\int_{\sigma^{-1} U_i^*} \frac{dx dy}{y^2} = \int_{U_i^*} \frac{dx dy}{y^2}.$$

This is finite by Lemma 1.4.4. The value $M(\phi)$ is obviously independent of the choice of x_0 and σ .

We denote by dv the measure on $\Gamma \backslash \mathbf{H}^*$ attached to the linear functional M . Let F be a fundamental domain of Γ , then by definition, we see

$$v(\Gamma \backslash \mathbf{H}^*) = v(\Gamma \backslash \mathbf{H}) = v(F).$$

Moreover, if A is a measurable set of \mathbf{H} , then $\pi(A)$ is also measurable on $\Gamma \backslash \mathbf{H}$ and we have the inequality

$$v(A) \geq v(\pi(A)).$$

Theorem 1.9.1. (Siegel) *Let Γ be a Fuchsian group. Then Γ is of the first kind if and only if $v(\Gamma \backslash \mathbf{H}^*)$ is finite.*

Proof. The only-if part is obvious. Assume that $v(\Gamma \backslash \mathbf{H}^*)$ is finite. Let F be the fundamental domain defined by (1.6.1). Take an interior point w of F . Let C be a connected component of the boundary of F , and $\{L_k\}_{k=M}^N$ ($-\infty \leq M \leq N \leq \infty$) all the sides of F contained in C . We assume that L_k and L_{k+1} lie side by side. If C is

a closed curve, then F is compact. Therefore $\Gamma \setminus \mathbf{H}^* = \Gamma \setminus \mathbf{H} = \pi(F)$ is also compact and Γ is of the first kind. Now assume that C is not a closed curve. Let z_k and z_{k+1} be the vertices of L_k . Let A_k be the triangle (whose sides are geodesics) determined by three vertices w, z_k, z_{k+1} , and let $\alpha_k, \beta_k, \gamma_k$ be the interior angles at the vertices w, z_k, z_{k+1} , respectively. Put $\omega_k = \gamma_{k-1} + \beta_k$ ($M < k \leq N$), then ω_k is the interior angle of F at z_k . Since the area of A_k is given by

$$v(A_k) = \pi - (\alpha_k + \beta_k + \gamma_k)$$

by Lemma 1.4.4, we see that

$$(1.9.1) \quad \sum_{k=m}^n v(A_k) = \begin{cases} \sum_{k=m+1}^n (\pi - \omega_k) + (\pi - \beta_m - \gamma_n) - \sum_{k=m}^n \alpha_k & (m \neq n), \\ \pi - \alpha_m - \beta_m - \gamma_m & (m = n), \end{cases}$$

for integers m, n such that $M \leq m \leq n \leq N$. If N is finite, then $z_{N+1} \in \mathbb{R} \cup \{\infty\}$ and $\gamma_N = 0$; otherwise, since only finitely many L_k intersect with a compact subset of \mathbf{H} by Theorem 1.6.2(3), there exists a subsequence $\{z_l\}$ of the sequence $\{z_k\}$ such that $\lim_{l \rightarrow \infty} d(w, z_l) = \infty$. Therefore, there exist infinitely many positive integers k such that $d(w, z_k) < d(w, z_{k+1})$. Thus $\beta_k \geq \gamma_k$, and therefore $\gamma_k \leq \pi/2$. In fact, the longer the side is, the larger the opposite angle is. (This can be easily verified by mapping the triangle into the unit disk with w to the origin.) Similarly, if M is finite, then $\beta_M = 0$; otherwise, there exist infinitely many negative integers k such that $\beta_k \leq \pi/2$. Therefore we get the inequalities

$$(1.9.2) \quad \sum_{k=M}^N v(A_k) \geq \begin{cases} \sum_{k=M+1}^N (\pi - \omega_k) - \sum_{k=M}^N \alpha_k & (N > M), \\ \pi - \alpha_M & (N = M), \end{cases}$$

from (1.9.1). Since we have these inequalities for all connected components of the

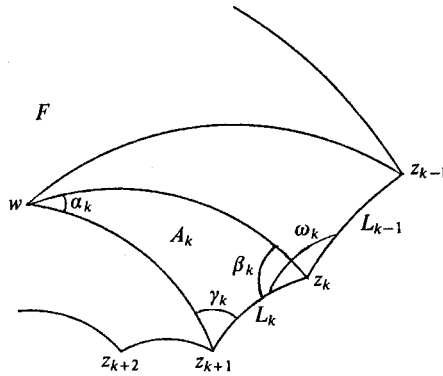

Fig. 1.9.1

boundary of F , we obtain, summing them over all components, the inequality

$$(1.9.3) \quad v(F) + 2\pi \geq \sum_{\omega} (\pi - \omega) + \Sigma' \pi,$$

where ω runs over all the interior angles of F in \mathbf{H} , and Σ' is taken over all the connected components of the boundary which themselves are sides (namely, $N = M$). In particular,

(1.9.4) *the number of the components consisting of one side is finite,*

and for any $\varepsilon > 0$, the number of the interior angles ω such that $\pi - \omega \geq \varepsilon$ is also finite. In particular, taking $\varepsilon = \pi/3$, we get

(1.9.5) *the number of ω such that $\omega \leq 2\pi/3$ is finite.*

Now let z be a vertex of F in \mathbf{H} . Since $\#\{\gamma \in \Gamma | \gamma\{z\} \cap F \neq \emptyset\}$ is finite by Theorem 1.6.2(3), there are only finitely many vertices of F equivalent to z by Γ . We write them as $z_1 = z, z_2 = \gamma_2 z, \dots, z_l = \gamma_l z$ ($\gamma_v \in \Gamma$). Let ω_v be the interior angle of F at z_v ($1 \leq v \leq l$). Then

$$(1.9.6) \quad \omega_1 + \dots + \omega_l = 2\pi/e \quad (e = |\Gamma_z/Z(\Gamma)|).$$

In fact, we can take a neighborhood U_1 of z_1 so that

$$(1.9.7) \quad \gamma U_1 \cap U_1 \neq \emptyset \Leftrightarrow \gamma \in \Gamma_{z_1},$$

and

$$(1.9.8) \quad \{\gamma \in \Gamma | \gamma \bar{U}_1 \cap F \neq \emptyset\} = \{\gamma \in \Gamma | \gamma\{z_1\} \cap F \neq \emptyset\}.$$

Put $F_v = U_1 \cap \gamma_v^{-1} F$. If $\mu \neq v$, then $\gamma F_v \cap F_\mu$ is either empty or a part of the boundary of F_μ for any $\gamma \in \Gamma_{z_1} - Z(\Gamma)$. In particular, the interior angle of $\bigcup_{v=1}^l F_v$ at z_1 is equal to $\omega_1 + \dots + \omega_l$. Moreover, let u be any point of U_1 . Since F is a fundamental domain for Γ , there exists $\gamma \in \Gamma$ such that $\gamma u \in F$. Then $\gamma U_1 \cap F \neq \emptyset$. Therefore by (1.9.8), we can write $\gamma = \gamma_v \gamma_0$ with $\gamma_0 \in \Gamma_{z_1}$. Since $\gamma_0 u = \gamma_v^{-1} \gamma u$, we get $\gamma_0 u \in F_v$. This proves that $\bigcup_{\gamma \in \Gamma_{z_1}} \gamma(\bigcup_{v=1}^l F_v) = U_1$. Since the action of Γ on \mathbf{H} is conformal, we obtain equality (1.9.6).

Now a side of F is either an arc or a line orthogonal to the real axis by Theorem 1.6.2(2), so that $0 < \omega_v < \pi$. Therefore, applying the equality (1.9.6) (considering the cases $e = 1, e = 2$ or $e > 2$, separately), we see that there exists at least one ω_v such that $\omega_v \leq 2\pi/3$. Hence if F has infinitely many vertices in \mathbf{H} , there exist infinitely many interior angles ω satisfying $\omega \leq 2\pi/3$; this contradicts (1.9.5). Therefore the vertices of F in \mathbf{H} are finite. Hence (1.9.4) implies that the number of the connected components of the boundary of F is finite, and also that

(1.9.9) *the number of the sides of F is finite.*

Next we shall prove that the summation of α_k taken over all the sides of F is equal to 2π ; in other words, F is completely covered by triangles A_k . In fact, suppose that it is not true. Then there exist two distinct geodesics passing through w such that they have no ends and the domain between them is included in F . Therefore F has

infinitely many triangles whose vertices are on $\mathbb{R} \cup \{\infty\}$. Since the areas of these triangles are π , we get $v(F) = \infty$; which is a contradiction.

Since F is a polygon whose sides are geodesics, any vertex x of F on $\mathbb{R} \cup \{\infty\}$ is the ends of two distinct sides of F . Let us show that x is a cusp of Γ . Let L_1 be a side of F which has x as its end. By definition, there exists $\gamma_1 \in \Gamma$ such that

$$L_1 = F \cap \gamma_1 F.$$

Since $\gamma_1^{-1} L_1 = \gamma_1^{-1} F \cap F$, $\gamma_1^{-1} L_1$ is also a side of F and $\gamma_1^{-1} x$ is also a vertex of F on $\mathbb{R} \cup \{\infty\}$. Put $x_1 = x$ and $x_2 = \gamma_1^{-1} x_1$. Let L_2 be the other side of F which has x_2 as the end. Similarly as above, there exists $\gamma_2 \in \Gamma$ such that $L_2 = F \cap \gamma_2 F$, and $x_3 = \gamma_2^{-1} x_2$ is also a vertex of F on $\mathbb{R} \cup \{\infty\}$. Repeating this process, we obtain the sequences $\{x_k\}$ of the vertices of F on $\mathbb{R} \cup \{\infty\}$ and $\{\gamma_k\}$ of the elements of Γ satisfying $\gamma_k^{-1} x_k = x_{k+1}$. Since the vertices of F on $\mathbb{R} \cup \{\infty\}$ are finite, there exist integers m, n ($m < n$) such that $x_m = x_n$. Therefore, we get $\gamma x_m = x_m$ with $\gamma = \gamma_{n-1}^{-1} \dots \gamma_m^{-1}$. Since x_m is a cusp of Γ by Lemma 1.6.3, x is also a cusp of Γ .

Let $\{x_1, \dots, x_t\}$ be the set of all vertices of F on $\mathbb{R} \cup \{\infty\}$. We shall show that any cusp x of Γ is equivalent to some x_v . Let U_v^* ($1 \leq v \leq t$) be the neighborhood of x_v such that

$$U_v^* = \sigma_v^{-1} U_1^*, \quad \sigma_v x_v = \infty \quad (\sigma_v \in SL_2(\mathbb{R})).$$

Since $F - \bigcup_{v=1}^t U_v^*$ is bounded, it is compact. Assume that x is not equivalent to any x_v . Then, by Lemmas 1.7.6 and 1.7.4, we can take a neighborhood U^* of x satisfying

$$\gamma U^* \cap \left(F - \bigcup_{v=1}^t U_v^* \right) = \emptyset, \quad \gamma U^* \cap U_v^* = \emptyset \quad (1 \leq v \leq t)$$

for any $\gamma \in \Gamma$. In particular, $\gamma U^* \cap F = \emptyset$ for any $\gamma \in \Gamma$. This contradicts the fact $\mathbf{H} = \bigcup_{\gamma \in \Gamma} \gamma F$. Therefore any cusp of Γ is equivalent to some x_v . Consequently we obtain

$$\begin{aligned} \Gamma \backslash \mathbf{H}^* &= \pi(F \cup \{x_1, \dots, x_t\}) \\ &= \pi \left(F - \bigcup_{v=1}^t U_v^* \right) \cup \left(\bigcup_{v=1}^t \pi(U_v^*) \right). \end{aligned}$$

Since $F - \bigcup_{v=1}^t U_v^*$ and the closures of $\pi(U_v^*)$'s in $\Gamma \backslash \mathbf{H}^*$ are compact, $\Gamma \backslash \mathbf{H}^*$ is compact. □

Corollary 1.9.2. *Let Γ be a Fuchsian group of the first kind. Any subgroup of Γ of finite index is also of the first kind.*

Proof. Let Γ_1 be a subgroup of Γ of finite index, and put $\Gamma = \bigsqcup_{v=1}^m \Gamma_1 \gamma_v$. Let F be a fundamental domain of Γ and $\pi_1: \mathbf{H} \rightarrow \Gamma_1 \backslash \mathbf{H}$ the canonical projection. Then, since $\pi_1(\bigcup_{v=1}^m \gamma_v F) = \Gamma_1 \backslash \mathbf{H}$, we see

$$v(\Gamma_1 \backslash \mathbf{H}) \leq \sum_{v=1}^m v(\gamma_v F) = mv(F) = mv(\Gamma \backslash \mathbf{H}) < \infty.$$

Therefore Γ_1 is of the first kind. □

The following corollary is proved in the proof of Theorem 1.9.1.

Corollary 1.9.3. *If Γ is a Fuchsian group of the first kind, and F is the fundamental domain of Γ defined by (1.6.1), then any vertex of F on $\mathbb{R} \cup \{\infty\}$ is a cusp of Γ and any cusp of Γ is equivalent to a vertex of F on $\mathbb{R} \cup \{\infty\}$.*

Chapter 2. Automorphic Forms

In this chapter, we explain the general theory of automorphic forms. *Hereafter Fuchsian groups always denote Fuchsian groups of the first kind.*

§2.1. Automorphic Forms

Let $\alpha = \begin{bmatrix} a & b \\ c & d \end{bmatrix}$ be an element of $GL_2^+(\mathbb{R})$. We put $j(\alpha, z) = cz + d$ as in (1.1.2). This is a holomorphic function on \mathbf{H} without zero. We recall the basic properties of $j(\alpha, z)$, since they are often used.

Let $\alpha, \beta \in GL_2^+(\mathbb{R})$ and $z \in \mathbf{H}$. Then

$$(2.1.1) \quad j(\alpha\beta, z) = j(\alpha, \beta z)j(\beta, z), \quad j(\alpha^{-1}, z) = j(\alpha, \alpha^{-1}z)^{-1};$$

$$(2.1.2) \quad d(\alpha z)/dz = \det(\alpha)/j(\alpha, z)^2;$$

$$(2.1.3) \quad \text{Im}(\alpha z) = \det(\alpha) \text{Im}(z)/|j(\alpha, z)|^2.$$

Moreover, by (2.1.1), we see that

$$(2.1.4) \quad j(\alpha, z) = \text{const. } j(\beta, z) \Leftrightarrow \alpha\beta^{-1} \in GL_2^+(\mathbb{R})_\infty.$$

Let k be an integer. For any function $f(z)$ on \mathbf{H} , we define the action of an element α of $GL_2^+(\mathbb{R})$ by

$$(2.1.5) \quad (f|_k \alpha)(z) = \det(\alpha)^{k/2} j(\alpha, z)^{-k} f(\alpha z) \quad (z \in \mathbf{H}).$$

By (2.1.1), we have

$$(2.1.6) \quad f|_k \alpha\beta = (f|_k \alpha)|_k \beta \quad (\alpha, \beta \in GL_2^+(\mathbb{R})).$$

For scalar matrices, we see in particular,

$$(2.1.7) \quad f|_k \begin{bmatrix} a & 0 \\ 0 & a \end{bmatrix} = \text{sgn}(a)^k f \quad (a \neq 0).$$

Let Γ be a Fuchsian group and k an integer. A meromorphic function $f(z)$ on \mathbf{H} is called an *automorphic form of weight k with respect to Γ* or simply a

Γ -automorphic form of weight k , if it satisfies

$$f|_k \gamma = f$$

for all elements $\gamma \in \Gamma$.

We denote by $\Omega_k(\Gamma)$ the set of all automorphic forms of weight k with respect to Γ . Then $\Omega_k(\Gamma)$ is a vector space over \mathbb{C} and

$$(2.1.8) \quad \text{if } \Gamma \supset \Gamma', \text{ then } \Omega_k(\Gamma) \subset \Omega_k(\Gamma');$$

$$(2.1.9) \quad \text{if } f \in \Omega_k(\Gamma) \text{ and } \alpha \in GL_2^+(\mathbb{R}), \text{ then } f|_k \alpha \in \Omega_k(\alpha^{-1} \Gamma \alpha);$$

$$(2.1.10) \quad \text{if } f \in \Omega_k(\Gamma) \text{ and } g \in \Omega_l(\Gamma), \text{ then } fg \in \Omega_{k+l}(\Gamma).$$

Furthermore by (2.1.7), we see that

$$(2.1.11) \quad \text{if } k \text{ is odd and } -1 \in \Gamma, \text{ then } \Omega_k(\Gamma) = \{0\}.$$

Let $\Omega(\Gamma)$ be the module generated by all $\Omega_k(\Gamma)$; namely

$$\Omega(\Gamma) = \sum_{k=-\infty}^{\infty} \Omega_k(\Gamma).$$

Then we have

Lemma 2.1.1. *The module $\Omega(\Gamma)$ is a graded ring.*

Proof. By (2.1.10), $\Omega(\Gamma)$ is obviously a ring. Now it follows from (2.1.4) that for elements α, β of Γ ,

$$j(\alpha, z) = j(\beta, z) \Leftrightarrow \alpha\beta^{-1} \in \Gamma_{\infty}.$$

Since we have $v(\Gamma \setminus \mathbf{H}) < \infty$ and the measure of $\Gamma_{\infty} \setminus \mathbf{H}$ is not finite, Γ/Γ_{∞} is an infinite set. Therefore there exists a set $\{\gamma_n\}_{n=-\infty}^{\infty}$ of the elements of Γ such that

$$j(\gamma_n, z) \neq j(\gamma_m, z) \quad \text{if } n \neq m.$$

Suppose

$$\sum_{k=M}^N f_k = 0$$

with $f_k \in \Omega_k(\Gamma)$. Then we see

$$\sum_{k=M}^N j(\gamma_m, z)^k f_k(z) = \sum_{k=M}^N f_k(\gamma_m z) = 0$$

for any γ_m . Consider these equations for m ($M \leq m \leq N$) as a system of the linear equations on $f_k(z)$ ($M \leq k \leq N$) with the coefficients $j(\gamma_m, z)^k$. Since

$$\det(j(\gamma_m, z)^k) = \pm \prod_{m=M}^N j(\gamma_m, z)^M \prod_{m < n} (j(\gamma_m, z) - j(\gamma_n, z)),$$

which does not vanish on \mathbf{H} , we get $f_k = 0$ for all k ($M \leq k \leq N$). \square

Assume that Γ has a cusp x . Let σ be an element of $SL_2(\mathbb{R})$ such that $\sigma x = \infty$.

Then by Theorem 1.5.4(2), we have

$$(2.1.12) \quad \sigma\Gamma_x\sigma^{-1} \cdot \{\pm 1\} = \left\{ \pm \begin{bmatrix} 1 & h \\ 0 & 1 \end{bmatrix}^m \mid m \in \mathbb{Z} \right\} \quad (h > 0).$$

Suppose that k is even. Since $f|_k\sigma^{-1} \in \Omega_k(\sigma\Gamma\sigma^{-1})$ for $f \in \Omega_k(\Gamma)$, we have $(f|_k\sigma^{-1})|_k \begin{bmatrix} 1 & h \\ 0 & 1 \end{bmatrix} = f|_k\sigma^{-1}$, namely,

$$(f|_k\sigma^{-1})(z+h) = (f|_k\sigma^{-1})(z).$$

Therefore there exists a function $g(w)$ on $\mathbf{K} - \{0\}$ such that

$$(2.1.13) \quad (f|_k\sigma^{-1})(z) = g(e^{2\pi iz/h}) \quad (z \in \mathbf{H}),$$

where \mathbf{K} is the unit disk. Since f is meromorphic on \mathbf{H} , g is so on $\mathbf{K} - \{0\}$. We say that an element f of $\Omega_k(\Gamma)$ is *meromorphic*, is *holomorphic*, or *has a zero at x* , if the above function g is meromorphic, is holomorphic, or has a zero at 0, respectively. When k is odd, we say that f is *meromorphic*, is *holomorphic*, or *has a zero at x* when f^2 is meromorphic, is holomorphic or has a zero at x , respectively.

Lemma 2.1.2. *The above definitions are independent of the choice of σ .*

Proof. We have only to prove our assertion for an even integer k . Let $f \in \Omega_k(\Gamma)$, and x be a cusp of Γ . We take $\sigma, h, g(w)$ as above. Let $\sigma_1, h_1, g_1(w)$ be another triple.

Then we can write $\sigma_1^{-1} = \sigma^{-1} \begin{bmatrix} a & b \\ 0 & a^{-1} \end{bmatrix}$, since $\sigma\sigma_1^{-1}\infty = \infty$. We see easily that $h_1 = h/a^2$ and

$$g_1(w) = a^k g(cw) \quad (w \in \mathbf{K}), \quad c = e^{2\pi iab/h}.$$

This proves the assertion. □

We are going to consider Fourier expansions of automorphic forms at cusps. Suppose that $f \in \Omega_k(\Gamma)$ is meromorphic at a cusp x of Γ . Take $\sigma \in SL_2(\mathbb{R})$ and $h > 0$ as above. First assume k is even, and let g be a meromorphic function on \mathbf{K} defined by (2.1.13). Denote the Laurent expansion of g at 0 by $g(w) = \sum_{n=N}^{\infty} a_n w^n$ ($a_N \neq 0$). Then we have the expansion of the form:

$$(2.1.14) \quad (f|_k\sigma^{-1})(z) = \sum_{n=N}^{\infty} a_n e^{2\pi inz/h}$$

on $\{z \in \mathbf{H} \mid \text{Im}(z) > l\}$ for a sufficiently large l . Next suppose that k is odd and $-1 \notin \Gamma$. From the above result, $f^2|_{2k}\sigma^{-1} = (f|_k\sigma^{-1})^2$ has such an expansion as in (2.1.14). Since we see

$$(f|_k\sigma^{-1})(z+h) = \begin{cases} (f|_k\sigma^{-1})(z) & \text{if } x \text{ is a regular cusp,} \\ -(f|_k\sigma^{-1})(z) & \text{otherwise,} \end{cases}$$

we get the expansion

$$(2.1.15) \quad (f|_k \sigma^{-1})(z) = \begin{cases} \sum_{\substack{n \geq N \\ n: \text{even}}} a_n e^{\pi i n z / h} & (a_N \neq 0) \text{ if } x \text{ is regular,} \\ \sum_{\substack{n \geq N \\ n: \text{odd}}} a_n e^{\pi i n z / h} & (a_N \neq 0) \text{ otherwise,} \end{cases}$$

on $\{z \in \mathbf{H} \mid \text{Im}(z) > l\}$ for a sufficiently large l . We call (2.1.14) and (2.1.15) the *Fourier expansion of $f(z)$* at a cusp x . The series in (2.1.14) and (2.1.15) are convergent absolutely and uniformly on any compact subset of $\{z \in \mathbf{H} \mid \text{Im}(z) > l\}$, and so also are on any compact subset of \mathbf{H} if $f(z)$ is holomorphic on \mathbf{H} . Further we note that

$f(z)$ is holomorphic (resp. has a zero) at x if and only if $N \geq 0$ (resp. $N > 0$).

For a Fuchsian group Γ , we put

$\mathcal{A}_k(\Gamma) = \{f \in \Omega_k(\Gamma) \mid f \text{ is meromorphic at all cusps of } \Gamma\}$;

$\mathcal{G}_k(\Gamma) = \{f \in \Omega_k(\Gamma) \mid f \text{ is holomorphic both on } \mathbf{H} \text{ and at all cusps of } \Gamma\}$;

$\mathcal{S}_k(\Gamma) = \{f \in \Omega_k(\Gamma) \mid f \text{ is holomorphic on } \mathbf{H} \text{ and has a zero at each cusp of } \Gamma\}$.

We call the elements of $\mathcal{A}_k(\Gamma)$, $\mathcal{G}_k(\Gamma)$ and $\mathcal{S}_k(\Gamma)$ *meromorphic automorphic forms*, *integral forms* and *cusp forms*, respectively. The spaces $\mathcal{A}_k(\Gamma)$, $\mathcal{G}_k(\Gamma)$ and $\mathcal{S}_k(\Gamma)$ are vector spaces over \mathbb{C} , and we easily see the following:

$$(2.1.16) \quad \Omega_k(\Gamma) \supset \mathcal{A}_k(\Gamma) \supset \mathcal{G}_k(\Gamma) \supset \mathcal{S}_k(\Gamma);$$

$$(2.1.17) \quad \text{if } \Gamma \text{ has no cusp, then } \Omega_k(\Gamma) = \mathcal{A}_k(\Gamma) \text{ and } \mathcal{G}_k(\Gamma) = \mathcal{S}_k(\Gamma);$$

$$(2.1.18) \quad \text{for any } \alpha \in GL_2^+(\mathbb{R}), \text{ the mapping " } f \mapsto f|_k \alpha \text{ " gives the following isomorphisms:}$$

$$\mathcal{A}_k(\Gamma) \simeq \mathcal{A}_k(\alpha^{-1} \Gamma \alpha), \quad \mathcal{G}_k(\Gamma) \simeq \mathcal{G}_k(\alpha^{-1} \Gamma \alpha), \quad \mathcal{S}_k(\Gamma) \simeq \mathcal{S}_k(\alpha^{-1} \Gamma \alpha);$$

$$(2.1.19) \quad \text{if } f \in \mathcal{A}_k(\Gamma) \text{ and } f \neq 0, \text{ then } 1/f \in \mathcal{A}_{-k}(\Gamma);$$

$$(2.1.20) \quad \text{if } f \in \mathcal{A}_k(\Gamma) \text{ and } g \in \mathcal{A}_l(\Gamma), \text{ then } fg \in \mathcal{A}_{k+l}(\Gamma);$$

$$(2.1.21) \quad \text{if } f \in \mathcal{G}_k(\Gamma) \text{ and } g \in \mathcal{G}_l(\Gamma), \text{ then } fg \in \mathcal{G}_{k+l}(\Gamma);$$

$$(2.1.22) \quad \text{if } f \in \mathcal{G}_k(\Gamma) \text{ and } g \in \mathcal{S}_l(\Gamma), \text{ then } fg \in \mathcal{S}_{k+l}(\Gamma).$$

We also put

$$\mathcal{A}(\Gamma) = \sum_k \mathcal{A}_k(\Gamma), \quad \mathcal{G}(\Gamma) = \sum_k \mathcal{G}_k(\Gamma), \quad \mathcal{S}(\Gamma) = \sum_k \mathcal{S}_k(\Gamma).$$

Since $\Omega(\Gamma)$ is a graded ring, we see that

$$(2.1.23) \quad \mathcal{A}(\Gamma), \mathcal{G}(\Gamma) \text{ and } \mathcal{S}(\Gamma) \text{ are graded rings.}$$

Moreover, (2.1.19) and (2.1.20) imply that $\mathcal{A}_0(\Gamma)$ is a field. We call $\mathcal{A}_0(\Gamma)$ the *automorphic function field with respect to Γ* and the elements of $\mathcal{A}_0(\Gamma)$ *automorphic functions with respect to Γ* . Let f be an automorphic function with respect to Γ . Since $(f|_0 \gamma)(z) = f(\gamma z)$, we can write

$$f(z) = \phi \circ \pi_\Gamma(z)$$

with a meromorphic function ϕ on $\Gamma \backslash \mathbf{H}$. Moreover, since $f(z)$ is meromorphic at each cusp of Γ , ϕ is a meromorphic function on the Riemann surface \mathfrak{R}_Γ .

Conversely, if ϕ is an element of the function field $K(\mathfrak{R}_\Gamma)$ of \mathfrak{R}_Γ , then the function $f(z)$ defined by $f(z) = \phi \circ \pi_\Gamma(z)$ ($z \in \mathbf{H}$) is obviously an element of $\mathcal{A}_0(\Gamma)$. Thus we obtain that

(2.1.24) $K(\mathfrak{R}_\Gamma)$ is isomorphic to $\mathcal{A}_0(\Gamma)$ through the correspondence " $\phi \mapsto \phi \circ \pi_\Gamma$ ".

Lemma 2.1.3. *Let Γ be a Fuchsian group and Γ' a subgroup of Γ of finite index. Then we have:*

$$\mathcal{A}_k(\Gamma) = \Omega_k(\Gamma) \cap \mathcal{A}_k(\Gamma'), \quad \mathcal{G}_k(\Gamma) = \Omega_k(\Gamma) \cap \mathcal{G}_k(\Gamma'), \quad \mathcal{S}_k(\Gamma) = \Omega_k(\Gamma) \cap \mathcal{S}_k(\Gamma').$$

In particular, $\mathcal{A}_k(\Gamma) \subset \mathcal{A}_k(\Gamma')$, $\mathcal{G}_k(\Gamma) \subset \mathcal{G}_k(\Gamma')$, $\mathcal{S}_k(\Gamma) \subset \mathcal{S}_k(\Gamma')$.

Proof. We have only to prove the equalities for even weights. We will prove the lemma only for cusp forms. Other cases can be proved similarly. If Γ has no cusp, the assertion is obvious; otherwise, it is sufficient to ascertain the conditions at cusps. If x is a cusp of Γ , then it is also a cusp of Γ' by Corollary 1.5.5. Take an element σ of $SL_2(\mathbb{R})$ and $h > 0$ satisfying (2.1.12), and put $l = [\Gamma_x \cdot \{\pm 1\} : \Gamma'_x \cdot \{\pm 1\}]$. By assumption, l is finite and we get

$$\sigma \Gamma'_x \sigma^{-1} \cdot \{\pm 1\} = \left\{ \pm \begin{bmatrix} 1 & lh \\ 0 & 1 \end{bmatrix}^m \mid m \in \mathbb{Z} \right\}.$$

Let f be an element of $\mathcal{S}_k(\Gamma)$, then we have the Fourier expansion of the form

$$\begin{aligned} (f|_k \sigma^{-1})(z) &= \sum_{n=1}^{\infty} a_n e^{2\pi i n z / h} \\ &= \sum_{n=1}^{\infty} a_n e^{2\pi i n l z / l h}, \end{aligned}$$

which is the Fourier expansion of f at x as an element of $\Omega_k(\Gamma')$. Hence by Corollary 1.5.5, we obtain $f \in \mathcal{S}_k(\Gamma')$. Conversely, suppose $f \in \Omega_k(\Gamma) \cap \mathcal{S}_k(\Gamma')$. Then it has the Fourier expansion at x :

$$(f|_k \sigma^{-1})(z) = \sum_{n=1}^{\infty} a_n e^{2\pi i n z / l h}.$$

Since f belongs to $\Omega_k(\Gamma)$, we have $(f|_k \sigma^{-1})(z+h) = (f|_k \sigma^{-1})(z)$. Hence $a_n = 0$ unless n is divisible by l , and we have

$$(f|_k \sigma^{-1})(z) = \sum_{n=1}^{\infty} a_{ln} e^{2\pi i n z / h},$$

which is the Fourier expansion of f at x as an element of $\Omega_k(\Gamma)$. This implies that f belongs to $\mathcal{S}_k(\Gamma)$. □

Theorem 2.1.4. *Assume that $f \in \Omega_k(\Gamma)$ is holomorphic on \mathbf{H} . If there exists a positive real number ν such that*

$$f(z) = O(\text{Im}(z)^{-\nu}) \quad (\text{Im}(z) \rightarrow 0)$$

uniformly with respect to $\text{Re}(z)$, then f belongs to $\mathcal{G}_k(\Gamma)$. Moreover if we can take ν so that $\nu < k$, then f belongs to $\mathcal{S}_k(\Gamma)$.

Proof. We may assume that k is even. If $\Gamma \backslash \mathbf{H}$ is compact, the assertion is obvious. Suppose that Γ has cusps, and let x be a cusp of Γ . First suppose x is on \mathbb{R} . Take $\sigma \in SL_2(\mathbb{R})$ so that $\sigma x = \infty$, and let h be a positive real number satisfying (2.1.12). Then $f|_k \sigma^{-1}$ has the expansion of the form:

$$(f|_k \sigma^{-1})(z) = \sum_{n=-\infty}^{\infty} a_n e^{2\pi i n z / h},$$

which is uniformly convergent on any compact subset of \mathbf{H} . The coefficient a_n is expressed as

$$(2.1.25) \quad a_n = \frac{1}{h} \int_{z_0}^{z_0+h} (f|_k \sigma^{-1})(z) e^{-2\pi i n z / h} dz$$

for any fixed $z_0 \in \mathbf{H}$. Write $\sigma^{-1} = \begin{bmatrix} a & b \\ c & d \end{bmatrix}$, then $c \neq 0$. Now $\text{Im}(\sigma^{-1}z) = \text{Im}(z)/|cz+d|^2 = O(1/\text{Im}(z))$ ($\text{Im}(z) \rightarrow \infty$) uniformly on $|\text{Re}(z)| \leq h/2$. Then by assumption, we have

$$(2.1.26) \quad \begin{aligned} (f|_k \sigma^{-1})(z) &= f(\sigma^{-1}z) j(\sigma^{-1}, z)^{-k} \\ &= O(\text{Im}(z)^{v-k}) \quad (\text{Im}(z) \rightarrow \infty), \end{aligned}$$

uniformly on $|\text{Re}(z)| \leq h/2$. Taking $z_0 = iy - h/2$ in (2.1.25), we get

$$|a_n| = O(y^{v-k} e^{2\pi n y / h}) \quad (y \rightarrow \infty).$$

Thus if $n < 0$, then $a_n = 0$. Moreover if $v < k$, then $a_0 = 0$. In other words, $f(z)$ is holomorphic at x , and if $v < k$, then $f(z)$ has a zero at x . Next suppose $x = \infty$. Then since Γ is of the first kind, we have $\Gamma \neq \Gamma_\infty$. Thus for $\gamma \in \Gamma - \Gamma_\infty$, a real point $\gamma\infty$ is a cusp of Γ equivalent to ∞ . Therefore $f(z)$ is holomorphic at all cusps of Γ , and if $v < k$, then $f(z)$ has a zero at any cusp. \square

Theorem 2.1.5. *Let $f(z)$ be an element of $\Omega_k(\Gamma)$. Then $f(z) \in \mathcal{S}_k(\Gamma)$ if and only if $f(z)\text{Im}(z)^{k/2}$ is bounded on \mathbf{H} .*

Proof. We may assume that k is even. The if-part is obvious by Theorem 2.1.4. Conversely, let $f(z)$ be a cusp form and put $g(z) = |f(z)|\text{Im}(z)^{k/2}$. Since $g(\gamma z) = g(z)$ for any $\gamma \in \Gamma$, we may regard $g(z)$ as a continuous function on $\Gamma \backslash \mathbf{H}$. If $\Gamma \backslash \mathbf{H}$ is compact, then $g(z)$ is bounded on $\Gamma \backslash \mathbf{H}$, and therefore bounded on \mathbf{H} . Assume that Γ has cusps. Since Γ has only finitely many inequivalent cusps, we have only to see that $g(z)$ is bounded on a neighborhood of a cusp of Γ . Let x_0 be a cusp of Γ , and σ an element of $SL_2(\mathbb{R})$ such that $\sigma x_0 = \infty$. Take a positive real number h so that $\sigma \Gamma_{x_0} \sigma^{-1} \cdot \{\pm 1\} = \left\{ \pm \begin{bmatrix} 1 & h \\ 0 & 1 \end{bmatrix}^m \mid m \in \mathbb{Z} \right\}$, and let $(f|_k \sigma^{-1})(z) = \sum_{n=1}^{\infty} a_n e^{2\pi i n z / h}$ be the Fourier expansion of f at x_0 . Then we see

$$\begin{aligned} g(\sigma^{-1}z) &= |(f|_k \sigma^{-1})(z)| \text{Im}(z)^{k/2} \\ &= \left| \sum_{n=1}^{\infty} a_n e^{2\pi i n z / h} \right| \text{Im}(z)^{k/2} \rightarrow 0 \quad (\text{Im}(z) \rightarrow \infty). \end{aligned}$$

Thus $g(z)$ is bounded on a neighborhood of x_0 . □

Corollary 2.1.6. *Let $f(z)$ be an element of $\mathcal{S}_k(\Gamma)$, x_0 a cusp of Γ and σ an element of $SL_2(\mathbb{R})$ such that $\sigma x_0 = \infty$. Let*

$$(f|_k \sigma^{-1})(z) = \sum_{n=1}^{\infty} a_n e^{\pi i n z/h}$$

be the Fourier expansion of f at x_0 . Then we have

$$a_n = O(n^{k/2}).$$

Proof. Put $g(z) = (f|_k \sigma^{-1})(z)$, then $g(z) \in \mathcal{S}_k(\sigma\Gamma\sigma^{-1})$. By Theorem 2.1.5, there exists a constant $M > 0$ such that $|g(z)| \leq M \text{Im}(z)^{-k/2}$. Therefore we get

$$\begin{aligned} |a_n| &= \frac{1}{2h} \left| \int_0^{2h} g(x + yi) e^{-\pi i n(x + yi)/h} dx \right| \\ &\leq M y^{-k/2} e^{\pi n y/h}. \end{aligned}$$

In particular, taking $y = 2/n$, we obtain $|a_n| \leq L n^{k/2}$ with $L = M e^{2\pi/h} 2^{-k/2}$. □

We note that the estimate of the Fourier coefficients a_n in Corollary 2.1.6 is not best possible. In fact, when Γ is a congruence modular group, it is proved that $a_n = O(n^{(k-1)/2})$ (c.f. Theorem 4.5.17).

It is convenient to generalize the notion of automorphic forms to automorphic forms with a character. Let Γ be a Fuchsian group, and χ a character of Γ of finite order. Put $\Gamma_\chi = \text{Ker}(\chi)$. Since it is a subgroup of Γ of finite index, it is also a Fuchsian group. We put

$$\begin{aligned} \Omega_k(\Gamma, \chi) &= \{f \in \Omega_k(\Gamma_\chi) \mid f|_k \gamma = \chi(\gamma)f \text{ for any } \gamma \in \Gamma\}, \\ \mathcal{A}_k(\Gamma, \chi) &= \Omega_k(\Gamma, \chi) \cap \mathcal{A}_k(\Gamma_\chi), \\ \mathcal{G}_k(\Gamma, \chi) &= \Omega_k(\Gamma, \chi) \cap \mathcal{G}_k(\Gamma_\chi), \\ \mathcal{S}_k(\Gamma, \chi) &= \Omega_k(\Gamma, \chi) \cap \mathcal{S}_k(\Gamma_\chi). \end{aligned}$$

In particular, if $\chi = 1$, then $\Omega_k(\Gamma, \chi) = \Omega_k(\Gamma)$, $\mathcal{A}_k(\Gamma, \chi) = \mathcal{A}_k(\Gamma)$, $\mathcal{G}_k(\Gamma, \chi) = \mathcal{G}_k(\Gamma)$, $\mathcal{S}_k(\Gamma, \chi) = \mathcal{S}_k(\Gamma)$. We call the elements of $\Omega_k(\Gamma, \chi)$ *automorphic forms of Γ with χ* .

By definition, we easily see the following (2.1.27) through (2.1.31).

(2.1.27) *Suppose $-1 \in \Gamma$. If $\chi(-1) \neq (-1)^k$, then $\Omega_k(\Gamma, \chi) = \{0\}$.*

(2.1.28) *Let Γ' be a subgroup of Γ_χ of finite index. Then we have:*

$$\begin{aligned} \mathcal{A}_k(\Gamma, \chi) &= \Omega_k(\Gamma, \chi) \cap \mathcal{A}_k(\Gamma'), \\ \mathcal{G}_k(\Gamma, \chi) &= \Omega_k(\Gamma, \chi) \cap \mathcal{G}_k(\Gamma'), \\ \mathcal{S}_k(\Gamma, \chi) &= \Omega_k(\Gamma, \chi) \cap \mathcal{S}_k(\Gamma'). \end{aligned}$$

(2.1.29) *Let Γ' be a subgroup of Γ of finite index. We also denote by χ the*

restriction of χ to Γ' . Then we have

$$\mathcal{A}_k(\Gamma, \chi) \subset \mathcal{A}_k(\Gamma', \chi), \quad \mathcal{G}_k(\Gamma, \chi) \subset \mathcal{G}_k(\Gamma', \chi), \quad \mathcal{S}_k(\Gamma, \chi) \subset \mathcal{S}_k(\Gamma', \chi).$$

(2.1.30) If $f \in \mathcal{A}_k(\Gamma, \chi)$ and $g \in \mathcal{A}_l(\Gamma, \psi)$, then $fg \in \mathcal{A}_{k+l}(\Gamma, \chi\psi)$.

(2.1.31) Let α be an element of $GL_2^+(\mathbb{R})$. Put $\Gamma' = \alpha^{-1}\Gamma\alpha$, and define the character χ' of Γ' by $\chi'(\alpha^{-1}\gamma\alpha) = \chi(\gamma)$. Then we obtain the following isomorphisms by the correspondence " $f \mapsto f|_k\alpha$ ":

$$\mathcal{A}_k(\Gamma, \chi) \simeq \mathcal{A}_k(\Gamma', \chi'), \quad \mathcal{G}_k(\Gamma, \chi) \simeq \mathcal{G}_k(\Gamma', \chi'), \quad \mathcal{S}_k(\Gamma, \chi) \simeq \mathcal{S}_k(\Gamma', \chi').$$

Let $f(z), g(z) \in \mathcal{G}_k(\Gamma, \chi)$. Assume that either $f(z)$ or $g(z)$ is a cusp form. Then $f(z)g(z) \in \mathcal{S}_{2k}(\Gamma, \chi^2)$, and therefore, $|f(z)g(z)|\text{Im}(z)^k$ is bounded on \mathbf{H} by Theorem 2.1.5. Furthermore if $\gamma \in \Gamma$, then

$$f(\gamma z)\overline{g(\gamma z)}\text{Im}(\gamma z)^k = f(z)\overline{g(z)}\text{Im}(z)^k.$$

Hence $\int_{\Gamma \backslash \mathbf{H}} f(z)\overline{g(z)}\text{Im}(z)^k dv(z)$ is meaningful and finite. We put

$$(2.1.32) \quad (f, g) = v(\Gamma \backslash \mathbf{H})^{-1} \int_{\Gamma \backslash \mathbf{H}} f(z)\overline{g(z)}\text{Im}(z)^k dv(z),$$

and call it the *Petersson inner product* (though it is defined only when either $f(z)$ or $g(z)$ is a cusp form). It induces an Hermitian inner product on $\mathcal{S}_k(\Gamma, \chi)$.

Let Γ_1 and Γ_2 be two Fuchsian groups, and χ_1, χ_2 characters of Γ_1, Γ_2 of finite order, respectively. Assume that there exists a Fuchsian group Γ' contained in $\text{Ker}(\chi_1) \cap \text{Ker}(\chi_2)$. For $f(z) \in \mathcal{S}_k(\Gamma_1, \chi_1)$ and $g(z) \in \mathcal{G}_k(\Gamma_2, \chi_2)$, we can define the Petersson inner product (f, g) by considering $f(z) \in \mathcal{S}_k(\Gamma')$ and $g(z) \in \mathcal{G}_k(\Gamma')$. We see easily that

$$(2.1.33) \quad (f, g) \text{ is independent of the choice of } \Gamma'.$$

We put

$$\mathcal{N}_k(\Gamma) = \{g \in \mathcal{G}_k(\Gamma) \mid (f, g) = 0 \text{ for all } f \in \mathcal{S}_k(\Gamma)\},$$

and

$$\mathcal{N}_k(\Gamma, \chi) = \{g \in \mathcal{G}_k(\Gamma, \chi) \mid (f, g) = 0 \text{ for all } f \in \mathcal{S}_k(\Gamma, \chi)\}.$$

Theorem 2.1.7. (1) $\mathcal{G}_k(\Gamma, \chi) = \mathcal{S}_k(\Gamma, \chi) \oplus \mathcal{N}_k(\Gamma, \chi)$.

(2) Let $\Gamma' \subset \Gamma$, and χ' be the restriction of χ to Γ' . Then

$$\mathcal{N}_k(\Gamma, \chi) = \mathcal{N}_k(\Gamma', \chi') \cap \mathcal{G}_k(\Gamma, \chi).$$

Proof. ([Shimura 12]) The first assertion is an easy exercise of Linear Algebra. Let us prove (2). There exists a normal subgroup Γ'' of Γ of finite index included in $\text{Ker}(\chi)$. We are going to show that $\mathcal{N}_k(\Gamma, \chi) \subset \mathcal{N}_k(\Gamma'')$. Let $g(z) \in \mathcal{N}_k(\Gamma, \chi)$. Since $g(z) \in \mathcal{G}_k(\Gamma'')$, we can write

$$g(z) = g_1(z) + f_1(z), \quad g_1(z) \in \mathcal{N}_k(\Gamma''), f_1(z) \in \mathcal{S}_k(\Gamma'').$$

Let $\gamma \in \Gamma$. Then $g|_k\gamma = \chi(\gamma)g$. Since $\mathcal{S}_k(\Gamma'')$ is stable under γ and $(h_1|_k\gamma, h_2) = (h_1, h_2|_k\gamma^{-1})$ for any $h_1 \in \mathcal{S}_k(\Gamma''), h_2 \in \mathcal{G}_k(\Gamma'')$, the space $\mathcal{N}_k(\Gamma'')$ is also stable under γ . Thus

$$g_1|_k\gamma \in \mathcal{N}_k(\Gamma''), \quad f_1|_k\gamma \in \mathcal{S}_k(\Gamma'').$$

Then $g_1|_k\gamma = \chi(\gamma)g_1$ and $f_1|_k\gamma = \chi(\gamma)f_1$ by applying (1) for Γ' and the trivial character. This implies $f_1(z) \in \mathcal{S}_k(\Gamma, \chi)$, and

$$(f_1, f_1) = (g - g_1, f_1) = (g, f_1) - (g_1, f_1) = 0.$$

Therefore $f_1(z) = 0$ and $g(z) = g_1(z) \in \mathcal{N}_k(\Gamma'')$. Since $\mathcal{S}_k(\Gamma', \chi') \subset \mathcal{S}_k(\Gamma'')$, we have

$$(f, g) = 0 \quad \text{for any } f(z) \in \mathcal{S}_k(\Gamma', \chi').$$

This implies $g(z) \in \mathcal{N}_k(\Gamma', \chi')$. Obviously the right-hand side is included in the left-hand side. □

§2.2. Differentials on Compact Riemann Surfaces

Let \mathfrak{R} be a Riemann surface, and m any integer. The set $\{(\phi_\mu, V_\mu, t_\mu)\}$ consisting of the triples (ϕ_μ, V_μ, t_μ) of a coordinate neighborhood V_μ of \mathfrak{R} , a local coordinate t_μ on V_μ and a meromorphic function ϕ_μ on V_μ is called the *local expression of a differential of degree m* , if the following conditions are satisfied:

- (i) $\{(V_\mu, t_\mu)\}$ is a coordinate system of \mathfrak{R} ;
- (ii) $\phi_\mu(\mathbf{a})(dt_\mu/dt_\nu)^m(\mathbf{a}) = \phi_\nu \mathbf{a}$ for any $\mathbf{a} \in V_\mu \cap V_\nu$, provided $V_\mu \cap V_\nu \neq \emptyset$.

Two local expressions $\{(\phi_\mu, V_\mu, t_\mu)\}$ and $\{(\phi'_\nu, V'_\nu, t'_\nu)\}$ of differentials of degree m are called *equivalent* if $\{(\phi_\mu, V_\mu, t_\mu)\} \cup \{(\phi'_\nu, V'_\nu, t'_\nu)\}$ also satisfies the above conditions (i) and (ii). We call the equivalent classes *differentials of \mathfrak{R} of degree m* . In particular, when $m = 1$, we simply call them the *differentials of \mathfrak{R}* . We denote by $D^m(\mathfrak{R})$ the set of all the differentials of degree m . For simplicity, we identify the differential of degree m with its local expression, and write

$$\omega = \{(\phi_\mu, V_\mu, t_\mu)\},$$

if there is no confusion.

Now let $\{(V_\mu, t_\mu)\}$ be a local coordinate system of \mathfrak{R} and take for ϕ_μ the function which identically vanishes on V_μ . Then $\{(\phi_\mu, V_\mu, t_\mu)\}$ is a differential of degree m for any m . We denote it by 0 . For a nonzero differential $\omega = \{(\phi_\mu, V_\mu, t_\mu)\}$ of degree m , each ϕ_μ is not identically 0 on V_μ , since \mathfrak{R} is connected. Thus we can define the differential ω^{-1} of degree $-m$ by

$$(2.2.1) \quad \omega^{-1} = \{(\phi_\mu^{-1}, V_\mu, t_\mu)\}.$$

For a differential $\omega = \{(\phi_\mu, V_\mu, t_\mu)\}$ of degree m and a complex number c , we put

$$(2.2.2) \quad c\omega = \{(c\phi_\mu, V_\mu, t_\mu)\},$$

which is also a differential of degree m .

Next let ω and ω' be differentials of degree m . Refining their local coordinate systems, if necessary, we can write as

$$\omega = \{(\phi_\mu, V_\mu, t_\mu)\}, \quad \omega' = \{(\phi'_\nu, V_\nu, t'_\nu)\}$$

with a common local coordinate system $\{(V_\mu, t_\mu)\}$. Then using these local

expressions, we define the *sum* $\omega + \omega'$ by

$$(2.2.3) \quad \omega + \omega' = \{(\phi_\mu + \phi'_\mu, V_\mu, t_\mu)\} \quad (\in D^m(\mathfrak{R})).$$

Moreover, for $\omega = \{(\phi_\mu, V_\mu, t_\mu)\} \in D^m(\mathfrak{R})$ and $\omega' = \{(\phi'_\mu, V_\mu, t_\mu)\} \in D^n(\mathfrak{R})$, we define the *product* $\omega\omega'$ by

$$(2.2.4) \quad \omega\omega' = \{(\phi_\mu\phi'_\mu, V_\mu, t_\mu)\} \quad (\in D^{m+n}(\mathfrak{R})).$$

The definitions (2.2.1) through (2.2.4) are all independent of the choice of their local expressions. It follows from (2.2.3) that $D^m(\mathfrak{R})$ is a vector space over \mathbb{C} . Furthermore, $D^0(\mathfrak{R})$ is a field by (2.2.1) through (2.2.4). Let $\omega = \{(\phi_\mu, V_\mu, t_\mu)\}$ be an element of $D^0(\mathfrak{R})$, and define the function ϕ on \mathfrak{R} by

$$(2.2.5) \quad \phi(\mathbf{a}) = \phi_\mu(\mathbf{a}) \quad \text{if } \mathbf{a} \in V_\mu.$$

Since $\phi_\mu = \phi_\nu$ on $V_\mu \cap V_\nu$, this is well-defined and ϕ is a meromorphic function on \mathfrak{R} . Conversely, let ϕ be an element of the function field $K(\mathfrak{R})$ of \mathfrak{R} , and define ϕ_μ by (2.2.5) for a local coordinate system $\{(V_\mu, t_\mu)\}$. Then $\{(\phi_\mu, V_\mu, t_\mu)\}$ is an element of $D^0(\mathfrak{R})$. Through this correspondence, $K(\mathfrak{R})$ and $D^0(\mathfrak{R})$ are isomorphic. Hereafter we identify $D^0(\mathfrak{R})$ with $K(\mathfrak{R})$ by this correspondence. Then $D^m(\mathfrak{R})$ is regarded as a vector space over $K(\mathfrak{R})$ through the product defined by (2.2.4). We put

$$D(\mathfrak{R}) = \sum_{m=-\infty}^{\infty} D^m(\mathfrak{R}),$$

then $D(\mathfrak{R})$ is a graded algebra over \mathbb{C} and over $K(\mathfrak{R})$.

Let ϕ be an element of $K(\mathfrak{R})$, and take a local coordinate system $\{(V_\mu, t_\mu)\}$ of \mathfrak{R} . We define a function ϕ_μ on V_μ by

$$\phi_\mu(\mathbf{a}) = (d\phi/dt_\mu)(\mathbf{a}) \quad (\mathbf{a} \in V_\mu).$$

Then $\{(\phi_\mu, V_\mu, t_\mu)\}$ is a differential of \mathfrak{R} , and we denote it by $d\phi$. The definition is obviously independent of the choice of a local coordinate system, and ϕ is a constant if and only if $d\phi = 0$.

Hereafter we assume that \mathfrak{R} is compact. Then $D^1(\mathfrak{R}) \neq \{0\}$, and therefore, $D^m(\mathfrak{R}) \neq \{0\}$ for any integer m , since $(d\phi)^m \in D^m(\mathfrak{R})$. If ω and ω' are two differentials of $D^m(\mathfrak{R})$ and $\omega \neq 0$, then we have $\omega^{-1}\omega' \in D^0(\mathfrak{R}) (= K(\mathfrak{R}))$; therefore we obtain

$$(2.2.6) \quad \dim_{K(\mathfrak{R})} D^m(\mathfrak{R}) = 1.$$

We denote by $\text{Div}(\mathfrak{R})$ the free module generated by all points of \mathfrak{R} , or

$$\text{Div}(\mathfrak{R}) = \left\{ \sum_{\mathbf{a} \in \mathfrak{R}} c_{\mathbf{a}} \mathbf{a} \mid c_{\mathbf{a}} \in \mathbb{Z} \text{ and } c_{\mathbf{a}} = 0 \text{ except for finitely many points } \mathbf{a} \right\},$$

and call it the *divisor group* of \mathfrak{R} . We call the elements of $\text{Div}(\mathfrak{R})$ *divisors* of \mathfrak{R} . For a divisor $\mathbf{a} = \sum_{\mathbf{a}} c_{\mathbf{a}} \mathbf{a}$ of \mathfrak{R} , we define the *degree of a* by

$$\deg(\mathbf{a}) = \sum_{\mathbf{a}} c_{\mathbf{a}} \quad (\in \mathbb{Z}).$$

We are going to define the divisors for functions and differentials of \mathfrak{R} . For an element $\phi (\neq 0)$ of $K(\mathfrak{R})$, we define the *divisor of ϕ* by

$$(2.2.7) \quad \operatorname{div}(\phi) = \sum_{\mathfrak{a} \in \mathfrak{R}} v_{\mathfrak{a}}(\phi) \mathfrak{a},$$

where $v_{\mathfrak{a}}(\phi)$ is the order of ϕ at \mathfrak{a} defined by (1.8.4). Since $v_{\mathfrak{a}}(\phi) = 0$ except for finitely many points \mathfrak{a} , $\operatorname{div}(\phi)$ is well-defined and an element of $\operatorname{Div}(\mathfrak{R})$. Moreover by virtue of (1.8.5), we see

$$(2.2.8) \quad \deg(\operatorname{div}(\phi)) = 0.$$

If $\phi, \psi \in K(\mathfrak{R})^{\times}$, then we see

$$(2.2.9) \quad \operatorname{div}(\phi\psi) = \operatorname{div}(\phi) + \operatorname{div}(\psi).$$

Therefore, if we put

$$\operatorname{Div}_1(\mathfrak{R}) = \{ \operatorname{div}(\phi) \mid \phi \in K(\mathfrak{R})^{\times} \},$$

then it is a submodule of $\operatorname{Div}(\mathfrak{R})$. We call $\operatorname{Div}_1(\mathfrak{R})$ the *principal divisor group*, and the quotient group $\operatorname{Div}(\mathfrak{R})/\operatorname{Div}_1(\mathfrak{R})$ the *divisor class group*. The elements of $\operatorname{Div}(\mathfrak{R})/\operatorname{Div}_1(\mathfrak{R})$ are called *divisor classes*.

Let $\omega \neq 0$ be a differential of degree m and $\omega = \{(\phi_{\mu}, V_{\mu}, t_{\mu})\}$. We put

$$v_{\mathfrak{a}}(\omega) = v_{\mathfrak{a}}(\phi_{\mu})$$

for any point $\mathfrak{a} \in V_{\mu}$. Since dt_{μ}/dt_{ν} is holomorphic and has no zeros on $V_{\mu} \cap V_{\nu}$, $v_{\mathfrak{a}}(\omega)$ is independent of the choice of a local expression of ω . Moreover, $v_{\mathfrak{a}}(\omega) = 0$ except for finitely many points \mathfrak{a} , since \mathfrak{R} is compact. Hence we can define the *divisor of ω* by

$$\operatorname{div}(\omega) = \sum_{\mathfrak{a} \in \mathfrak{R}} v_{\mathfrak{a}}(\omega) \mathfrak{a},$$

which is an element of $\operatorname{Div}(\mathfrak{R})$. If $m = 0$, then it is nothing but the divisor of a function defined above. If $\omega \in D^m(\mathfrak{R})$, $\omega' \in D^n(\mathfrak{R})$ and $\omega \neq 0$, $\omega' \neq 0$, then we get

$$(2.2.10) \quad \operatorname{div}(\omega\omega') = \operatorname{div}(\omega) + \operatorname{div}(\omega').$$

Therefore by (2.2.6), we see

$$(2.2.11) \quad \{ \operatorname{div}(\omega) \mid \omega \in D^m(\mathfrak{R}) - \{0\} \} \text{ is a divisor class.}$$

Let $\mathfrak{a} = \sum_{\mathfrak{a}} c_{\mathfrak{a}} \mathfrak{a}$ be a divisor. When $c_{\mathfrak{a}} \geq 0$ for all \mathfrak{a} , we say that \mathfrak{a} is *positive* and write $\mathfrak{a} \geq 0$. We put, for a divisor \mathfrak{a} ,

$$L(\mathfrak{a}) = \{ \phi \in K(\mathfrak{R}) \mid \phi = 0 \text{ or } \operatorname{div}(\phi) + \mathfrak{a} \geq 0 \}.$$

It is known that $L(\mathfrak{a})$ is a finite dimensional vector space over \mathbb{C} . By (2.2.8), we see

$$(2.2.12) \quad L(0) = \mathbb{C};$$

$$(2.2.13) \quad L(\mathfrak{a}) = \{0\} \text{ if } \deg(\mathfrak{a}) < 0.$$

We put

$$l(\mathfrak{a}) = \dim_{\mathbb{C}} L(\mathfrak{a}).$$

Then the following theorem is known (see [Lang]).

Theorem 2.2.1 (Riemann–Roch). *Let \mathfrak{R} be a compact Riemann surface of genus g . Fix a nonzero differential ω of \mathfrak{R} . Then we have*

$$l(\mathbf{a}) = \deg(\mathbf{a}) - g + 1 + l(\operatorname{div}(\omega) - \mathbf{a})$$

for any divisor \mathbf{a} of \mathfrak{R} .

The following corollary is easily deduced from this.

Corollary 2.2.2. *Let \mathfrak{R} be a compact Riemann surface of genus g .*

(1) *If ω is a nonzero differential of \mathfrak{R} , then we have*

$$\deg(\operatorname{div}(\omega)) = 2g - 2, \quad l(\operatorname{div}(\omega)) = g.$$

(2) *If ω is a nonzero differential of \mathfrak{R} of degree m , then we have*

$$\deg(\operatorname{div}(\omega)) = 2m(g - 1).$$

(3) *If \mathbf{a} is a divisor of \mathfrak{R} such that $\deg(\mathbf{a}) > 2g - 2$, then we have*

$$l(\mathbf{a}) = \deg(\mathbf{a}) - g + 1.$$

Let ω be a differential of degree m . We say that ω is *holomorphic*, if either $\omega = 0$ or $\operatorname{div}(\omega) \geq 0$. We denote by $D_0^m(\mathfrak{R})$ the space of the holomorphic differentials of degree m . Since

$$L(\operatorname{div}(\omega_1)) = \{\phi \in K(\mathfrak{R}) \mid \phi = 0 \text{ or } \operatorname{div}(\phi\omega_1) \geq 0\}$$

for a nonzero differential ω_1 of \mathfrak{R} , we get the isomorphism:

$$\begin{aligned} L(\operatorname{div}(\omega_1)) &\simeq \{\omega \in D^1(\mathfrak{R}) \mid \omega = 0 \text{ or } \operatorname{div}(\omega) \geq 0\} \\ &= D_0^1(\mathfrak{R}). \end{aligned}$$

Therefore by Corollary 2.2.2(1), we obtain

$$(2.2.14) \quad \dim_{\mathbb{C}} D_0^1(\mathfrak{R}) = g.$$

§2.3. Automorphic Forms and Differentials

We are going to connect automorphic forms for a Fuchsian group Γ and differentials on the Riemann surface \mathfrak{R}_{Γ} .

First we assume that $k = 2m$, and define a mapping from $\mathcal{A}_k(\Gamma)$ to $D^m(\mathfrak{R}_{\Gamma})$. Let $\pi = \pi_{\Gamma}$ be the natural projection from \mathbf{H}^* onto \mathfrak{R}_{Γ} , and f an element of $\mathcal{A}_k(\Gamma)$. For a point \mathbf{a} of \mathfrak{R}_{Γ} , take a point z_0 of \mathbf{H}^* such that $\pi(z_0) = \mathbf{a}$. Let $U_{z_0}^*$ be a neighborhood of z_0 in \mathbf{H}^* satisfying the following conditions:

$$(2.3.1) \quad \gamma U_{z_0}^* \cap U_{z_0}^* \neq \emptyset \text{ if and only if } \gamma \in \Gamma_{z_0};$$

$$(2.3.2) \quad \text{if } \gamma \in \Gamma_{z_0}, \text{ then } \gamma U_{z_0}^* = U_{z_0}^*.$$

Let t_a be a local coordinate on a neighborhood $V_a = \pi(U_{z_0}^*)$ of a defined in §1.8.

1° Suppose z_0 is a point of \mathbf{H} . We define a function $g(z)$ on $U_{z_0}^*$ by

$$(2.3.3) \quad g(z) = f(z)(d(t_a \circ \pi(z))/dz)^{-m} \quad (z \in U_{z_0}^*).$$

Since $t_a \circ \pi(\gamma z) = t_a \circ \pi(z)$ for any $\gamma \in \Gamma_{z_0}$, we see

$$(2.3.4) \quad \begin{aligned} d(t_a \circ \pi \circ \gamma(z))/d(\gamma z) &= (d(\gamma z)/dz)^{-1} d(t_a \circ \pi(z))/dz \\ &= j(\gamma, z)^2 d(t_a \circ \pi(z))/dz \quad (\gamma \in \Gamma_{z_0}). \end{aligned}$$

Thus we get $g(\gamma z) = g(z)$ for any $\gamma \in \Gamma_{z_0}$, and therefore, there exists a function ϕ_a on V_a satisfying

$$(2.3.5) \quad \phi_a \circ \pi(z) = g(z) \quad (z \in U_{z_0}^*).$$

Since $f(z)$ is meromorphic, so is ϕ_a . Moreover, if a point b of \mathfrak{R}_F is not a cusp and $V_a \cap V_b \neq \emptyset$, then

$$(2.3.6) \quad \phi_a(c)(dt_a/dt_b)^m(c) = \phi_b(c)$$

for any $c \in V_a \cap V_b$.

2° Let z_0 be a cusp. Put $U_{z_0} = U_{z_0}^* - \{z_0\}$ and define a function $g(z)$ on U_{z_0} by

$$(2.3.7) \quad g(z) = f(z)(d(t_a \circ \pi(z))/dz)^{-m} \quad (z \in U_{z_0}).$$

By a similar argument as in 1°, we see $g(\gamma z) = g(z)$ for $\gamma \in \Gamma_{z_0}$. Thus there exists a function ϕ_a on $V_a - \{a\}$ satisfying

$$\phi_a \circ \pi(z) = g(z) \quad (z \in U_{z_0}).$$

Since $f(z)$ is meromorphic on U_{z_0} , so is ϕ_a on $V_a - \{a\}$. Take an element σ of $SL_2(\mathbb{R})$ satisfying $\sigma z_0 = \infty$, and let h be a positive real number such that

$\sigma \Gamma_{z_0} \sigma^{-1} \cdot \{\pm 1\} = \left\{ \pm \begin{bmatrix} 1 & h \\ 0 & 1 \end{bmatrix}^m \mid m \in \mathbb{Z} \right\}$. We define a local coordinate t_a by $t_a \circ \pi(z) = e^{2\pi i \sigma z/h}$, and put $c = (2\pi i/h)^{-m}$. Then we see

$$(2.3.8) \quad \begin{aligned} \phi_a \circ \pi(z) &= cf(z)(d(\sigma z)/dz)^{-m}(t_a \circ \pi(z))^{-m} \\ &= cf(z)j(\sigma, z)^{2m}(t_a \circ \pi(z))^{-m} \\ &= c(f|_{2m} \sigma^{-1})(\sigma z)(t_a \circ \pi(z))^{-m} \end{aligned}$$

on U_{z_0} . Since f is meromorphic at z_0 , so is ϕ_a at a . Moreover, if b is a point of \mathfrak{R}_F , and $V_a \cap V_b \neq \emptyset$, then we see easily that (2.3.6) also holds in this case.

Thus we have proved that $\{(\phi_a, V_a, t_a)\}$ is a differential of degree m of \mathfrak{R}_F , which we denote by ω_f or $\omega(f)$. Then we easily see that

$$\omega_{fg} = \omega_f \omega_g \quad \text{for } f \in \mathcal{A}_{2m}(\Gamma), \quad g \in \mathcal{A}_{2n}(\Gamma),$$

$$\omega_{f+g} = \omega_f + \omega_g \quad \text{for } f, g \in \mathcal{A}_{2m}(\Gamma).$$

Conversely, let $\omega = \{(\phi_\mu, V_\mu, t_\mu)\}$ be an element of $D^m(\mathfrak{R}_F)$. We define a function $f(z)$ on \mathbf{H} by

$$f(z) = \phi_\mu(\pi(z))(d(t_\mu \circ \pi(z))/dz)^m \quad (z \in \mathbf{H} \cap \pi^{-1}(V_\mu)).$$

Then $f(z)$ is well-defined and an element of $\mathcal{A}_{2m}(\Gamma)$. Furthermore we see

$$\omega = \omega_f.$$

Summing up all together, we obtain the following

Theorem 2.3.1. *Put $\mathcal{A}(\Gamma)_{\text{even}} = \sum_m \mathcal{A}_{2m}(\Gamma)$. Then $\mathcal{A}(\Gamma)_{\text{even}}$ is isomorphic to $D(\mathfrak{R}_\Gamma) = \sum_m D^m(\mathfrak{R}_\Gamma)$ as graded algebras over \mathbb{C} by the correspondence “ $f \mapsto \omega_f$ ”. In particular, $\mathcal{A}_{2m}(\Gamma) \neq \{0\}$.*

Let f be a nonzero element of $\mathcal{A}_{2m}(\Gamma)$. We use the same notations as in $1^\circ, 2^\circ$. Let $\mathfrak{a} = \pi(z_0) \in \mathfrak{R}_\Gamma$ with $z_0 \in \mathbf{H}^*$. First suppose $z_0 \in \mathbf{H}$. Take an element ρ of $SL_2(\mathbb{C})$ so that $\rho\mathbf{H} = \mathbf{K}$ and $\rho z_0 = 0$. Then we can take a local coordinate $t_{\mathfrak{a}}$ on $V_{\mathfrak{a}}$ so that $t_{\mathfrak{a}} \circ \pi(z) = (\rho z)^e$ ($z \in U_{z_0}^*$), where e is the ramification index at \mathfrak{a} . Using this local coordinate $t_{\mathfrak{a}}$, we can rewrite (2.3.3) as

$$\phi_{\mathfrak{a}} \circ \pi(z) = f(z)(d(\rho z)/dz)^{-m}(e(\rho z)^{e-1})^{-m} \quad (z \in U_{z_0}^*).$$

In other words, putting $w = \rho z$, we have

$$\phi_{\mathfrak{a}} \circ \pi \circ \rho^{-1}(w) = e^{-m} f(\rho^{-1}w)(d(\rho^{-1}w)/dw)^m w^{-m(e-1)} \quad (w \in \rho(U_{z_0}^*)).$$

Comparing the orders in w on both sides, we get

$$(2.3.9) \quad \text{ord}_w(\phi_{\mathfrak{a}} \circ \pi \circ \rho^{-1}) = \text{ord}_w(f(\rho^{-1}w)(d(\rho^{-1}w)/dw)^m) - m(e-1).$$

Since $t_{\mathfrak{a}} \circ \pi \circ \rho^{-1}(w) = w^e$, we have

$$(2.3.10) \quad \text{ord}_w(\phi_{\mathfrak{a}} \circ \pi \circ \rho^{-1}) = e v_{\mathfrak{a}}(\phi_{\mathfrak{a}}) = e v_{\mathfrak{a}}(\omega_f).$$

On the other hand, we have

$$(2.3.11) \quad \text{ord}_w(f(\rho^{-1}w)(d(\rho^{-1}w)/dw)^m) = \text{ord}_{z-z_0}(f),$$

since $d(\rho z)/dz$ has neither a zero nor a pole at z_0 . It is natural to define

$$v_{\mathfrak{a}}(f) = \frac{1}{e} \text{ord}_{z-z_0}(f).$$

Then, from (2.3.9) through (2.3.11), we obtain

$$(2.3.12) \quad v_{\mathfrak{a}}(\omega_f) = v_{\mathfrak{a}}(f) - m(1 - 1/e).$$

In particular, the definition of $v_{\mathfrak{a}}(f)$ is independent of the choice of both z_0 and ρ . We note that when $m = 1$, for $\mathfrak{a} = \pi(z_0)$ ($z_0 \in \mathbf{H}$),

$$(2.3.13) \quad \begin{aligned} \omega_f &\text{ is holomorphic at } \mathfrak{a} \\ \Leftrightarrow v_{\mathfrak{a}}(\omega_f) &\geq 0 \\ \Leftrightarrow v_{\mathfrak{a}}(f) &\geq 0 \\ \Leftrightarrow f &\text{ is holomorphic at } z_0. \end{aligned}$$

Next assume that z_0 is a cusp of Γ . Take σ, h, t_a as in 2° above. Since

$$\begin{aligned} (f|_{2m}\sigma^{-1})(\sigma z) &= \sum_{n=N}^{\infty} a_n e^{2\pi i n \sigma z/h} \quad (a_N \neq 0) \\ &= \sum_{n=N}^{\infty} a_n (t_a \circ \pi(z))^n, \end{aligned}$$

we get

$$v_a(\phi_a) = N - m$$

by (2.3.8). We put $v_a(f) = N$, then we obtain

$$(2.3.14) \quad v_a(\omega_f) = v_a(f) - m.$$

In particular, $v_a(f)$ is independent of the choice of both z_0 and σ . When $m = 1$, we see for a cusp $a = \pi(z_0)$,

$$(2.3.15) \quad \begin{aligned} \omega_f \text{ is holomorphic at } a \\ \Leftrightarrow v_a(f) \geq 1 \\ \Leftrightarrow f \text{ has a zero at } z_0. \end{aligned}$$

Consequently, by (2.3.13) and (2.3.15), we obtain the following

Theorem 2.3.2. *The correspondence “ $f \mapsto \omega_f$ ” induces the following isomorphism:*

$$\mathcal{S}_2(\Gamma) \simeq D_0^1(\mathfrak{R}_\Gamma).$$

To define divisors of automorphic forms, we shall generalize the notion of the divisors. For a compact Riemann surface \mathfrak{R} , we put

$$\begin{aligned} \text{Div}(\mathfrak{R})_{\mathbb{Q}} &= \text{Div}(\mathfrak{R}) \otimes_{\mathbb{Z}} \mathbb{Q} \\ &= \left\{ \sum_{a \in \mathfrak{R}} c_a a \mid c_a \in \mathbb{Q} \text{ and } c_a = 0 \text{ except for finitely many points } a \right\}. \end{aligned}$$

We call the elements of $\text{Div}(\mathfrak{R})_{\mathbb{Q}}$ *divisors with rational coefficients*.

Now let f be a nonzero element of $\mathcal{A}_{2m}(\Gamma)$. We have $v_a(f) = v_a(\omega_f)$ for every ordinary point a . Then the number of the points $a \in \mathfrak{R}_\Gamma$ such that $v_a(f) \neq 0$ is finite, since elliptic points and cusps and points a such that $v_a(\omega_f) \neq 0$ are only finite. Therefore, we can define

$$\text{div}(f) = \sum_{a \in \mathfrak{R}_\Gamma} v_a(f) a$$

as an element of $\text{Div}(\mathfrak{R}_\Gamma)_{\mathbb{Q}}$. By (2.3.12), (2.3.14) and Corollary 2.2.2, we get the following

Theorem 2.3.3. *Let k be an even integer. For a nonzero element f of $\mathcal{A}_k(\Gamma)$, we have*

$$\begin{aligned} \text{div}(f) &= \text{div}(\omega_f) + \frac{k}{2} \sum_a (1 - 1/e_a) a, \\ \text{deg}(\text{div}(f)) &= k(g - 1) + \frac{k}{2} \sum_a (1 - 1/e_a), \end{aligned}$$

where e_a is the ramification index of a and g is the genus of \mathfrak{R}_Γ . We understand $1/e_a = 0$ if a is a cusp.

Remark 2.3.1. Since $1 - 1/e_a = 0$ for ordinary points a , the summation in the right-hand side is virtually a finite sum.

Remark 2.3.2. When $m = 0$, the divisor $\text{div}(f)$ for a nonzero element f of $\mathcal{A}_0(\Gamma)$ is nothing but the divisor of f as an element of $K(\mathfrak{R}_\Gamma)^\times$.

Remark 2.3.3. Let $f \in \mathcal{A}_{2m}(\Gamma)$. Then

$$\omega_f \circ \pi = f(z)(dz)^m$$

as differentials of degree m of \mathbf{H} . Keeping this in mind, if we define

$$(2.3.16) \quad \text{div}(dz) = - \sum_a (1 - 1/e_a) a,$$

then we have

$$(2.3.17) \quad \text{div}(\omega_f) = \text{div}(f) + m \text{div}(dz).$$

Corollary 2.3.4. Let k be an even integer, and assume that Γ has cusps. Denote by r the number of inequivalent cusps of Γ , and by s the number of inequivalent elliptic points. Let x be a cusp of Γ and σ an element of $SL_2(\mathbb{R})$ such that $\sigma x = \infty$. Let $f(z)$, $g(z)$ be elements of $\mathcal{G}_k(\Gamma)$ and

$$(f|_k \sigma^{-1})(z) = \sum_{n=0}^{\infty} a_n e^{2\pi i n z/h}, \quad (h|_k \sigma^{-1})(z) = \sum_{n=0}^{\infty} b_n e^{2\pi i n z/h}$$

be the Fourier expansions of f , h at x . If $a_n = b_n$ for every $n \leq k(g-1) + k(r+s)/2$, then $f(z) = h(z)$. Here g is the genus of \mathfrak{R}_Γ .

Proof. Put $\omega = \omega_{f-h}$. Suppose $\omega \neq 0$. Then, by (2.3.14), $v_{\pi(x)}(\omega) \geq k(g-1) + k(r+s-1)/2 + 1$. Since both f and h are holomorphic, Theorem 2.3.3 implies that ω is holomorphic at all points except for cusps and elliptic points. Furthermore, $v_a(\omega) \geq -k/2$ for all elliptic points and cusps other than $\pi(x)$ by (2.3.12) and (2.3.14). Therefore $\deg(\text{div}(\omega)) \geq k(g-1) + 1$; this contradicts Corollary 2.2.2. Consequently, $\omega = 0$ and $f = h$. \square

Next we consider the case when k is odd. Assume $-1 \notin \Gamma$. Let $f(z)$ be a nonzero element of $\mathcal{A}_k(\Gamma)$. Since $f(z)^2$ belongs to $\mathcal{A}_{2k}(\Gamma)$, we may put

$$v_a(f) = v_a(f^2)/2 \quad (a \in \mathfrak{R}_\Gamma).$$

We define $\text{div}(f)$ by

$$\text{div}(f) = \sum_{a \in \mathfrak{R}_\Gamma} v_a(f) a.$$

Theorem 2.3.5. *Let k be an odd integer. Assume $-1 \notin \Gamma$. For a nonzero element f of $\mathcal{A}_k(\Gamma)$, we have:*

$$(1) \quad \operatorname{div}(f) = \frac{1}{2} \operatorname{div}(\omega_{f^2}) + \frac{k}{2} \sum_{\mathfrak{a}} (1 - 1/e_{\mathfrak{a}}) \mathfrak{a},$$

$$\operatorname{deg}(\operatorname{div}(f)) = k(g - 1) + \frac{k}{2} \sum_{\mathfrak{a}} (1 - 1/e_{\mathfrak{a}});$$

$$(2) \quad v_{\mathfrak{a}}(f) \equiv \begin{cases} 1/2 & \text{mod } \mathbb{Z}, \text{ if } \mathfrak{a} \text{ is an irregular cusp,} \\ \text{an integer}/e_{\mathfrak{a}} & \text{mod } \mathbb{Z}, \text{ if } \mathfrak{a} \text{ is an elliptic point,} \\ 0 & \text{mod } \mathbb{Z}, \text{ otherwise;} \end{cases}$$

$$(3) \quad v_{\mathfrak{a}}(\omega_{f^2}) = \begin{cases} \text{odd,} & \text{if } \mathfrak{a} \text{ is a regular cusp,} \\ \text{even,} & \text{otherwise.} \end{cases}$$

Here $e_{\mathfrak{a}}$ denotes the ramification index at \mathfrak{a} . We understand $1/e_{\mathfrak{a}} = 0$ if \mathfrak{a} is a cusp.

Proof. The assertion (1) is easily seen by Theorem 2.3.3. Let us prove (2). When \mathfrak{a} is a cusp, the assertion easily follows from (2.1.15). Suppose \mathfrak{a} is not a cusp and let z_0 be a point of \mathbf{H} such that $\pi(z_0) = \mathfrak{a}$. Then

$$v_{\mathfrak{a}}(f) = v_{\mathfrak{a}}(f^2)/2 = \operatorname{ord}_t(f^2)/2e_{\mathfrak{a}} = \operatorname{ord}_t(f)/e_{\mathfrak{a}}, \quad (t = z - z_0).$$

This implies (2). By definition, we have

$$v_{\mathfrak{a}}(\omega_{f^2}) = 2v_{\mathfrak{a}}(f) - k(1 - 1/e_{\mathfrak{a}}).$$

Thus, if \mathfrak{a} is not an elliptic point, the assertion follows from (2). Assume that \mathfrak{a} is an elliptic point. Then $e_{\mathfrak{a}}$ is odd by Lemma 1.5.6(2). Put $v_{\mathfrak{a}}(\omega_{f^2}) = u$. Since $ue_{\mathfrak{a}} + k(e_{\mathfrak{a}} - 1)$ is even by (2), u must be also even. Therefore we get (3). \square

§2.4. The Measure of $\Gamma \backslash \mathbf{H}^*$

In this section, we calculate the measure of $\Gamma \backslash \mathbf{H}^*$ using the genus g of $\Gamma \backslash \mathbf{H}^*$ and ramification indices.

Lemma 2.4.1. *Let m be the least common multiple of the orders of all elliptic points of Γ . Then there exists a nonzero element of $\mathcal{A}_{2m}(\Gamma)$ which has neither zeros nor poles at any cusp and any elliptic point of Γ .*

Proof. By definition, we have only to show that there exists a nonzero element f of $\mathcal{A}_{2m}(\Gamma)$ such that $v_{\mathfrak{a}}(f) = 0$ for all elliptic points and cusps \mathfrak{a} of \mathfrak{R}_{Γ} . Let k be a nonzero element of $\mathcal{A}_{2m}(\Gamma)$. We note that $\operatorname{div}(k)$ belongs to $\operatorname{Div}(\mathfrak{R}_{\Gamma})$ by the definition of m and Theorem 2.3.3. Let $\{\mathfrak{a}_1, \dots, \mathfrak{a}_r\}$ be the set of all elliptic points and all cusps of \mathfrak{R}_{Γ} . Take an integer n satisfying

$$-\operatorname{deg}(\operatorname{div}(k)) - 1 + n > 2g - 2.$$

Let \mathbf{b} be a point of \mathfrak{R}_Γ which is neither an elliptic point nor a cusp, and put

$$\begin{aligned} \mathbf{a} &= -\operatorname{div}(k) + n\mathbf{b}, \\ \mathbf{b}_\mu &= -\operatorname{div}(k) - \mathbf{a}_\mu + n\mathbf{b} \quad (1 \leq \mu \leq r). \end{aligned}$$

Then we see $L(\mathbf{a}) \supset L(\mathbf{b}_\mu)$ and, by Corollary 2.2.2(3),

$$\dim L(\mathbf{a}) - \dim L(\mathbf{b}_\mu) = 1,$$

so that there exists a nonzero element $h(z)$ of $\mathcal{A}_0(\Gamma) (\simeq K(\mathfrak{R}_\Gamma))$ such that

$$h \in L(\mathbf{a}) - \bigcup_{\mu=1}^r L(\mathbf{b}_\mu).$$

Put $f = k/h$; this is the desired one, since

$$v_{\mathbf{a}_\mu}(h) = v_{\mathbf{a}_\mu}(k) \quad (1 \leq \mu \leq r). \quad \square$$

Lemma 2.4.2. *Let k be an even integer, x_0 a cusp of Γ , and f a nonzero element of $\mathcal{A}_k(\Gamma)$ which has neither a zero nor a pole at x_0 . Let C be a curve contained in a neighborhood of x_0 satisfying the following conditions:*

- (i) $\pi(C)$ is a circle around $\pi(x_0)$ oriented counterclockwise;
- (ii) C corresponds one-to-one to $\pi(C)$ except for the initial point and the terminal point.

If C tends to x_0 with respect to the topology of \mathbf{H}^* , then we have

$$\lim \int_C d \log f = \lim \int_C y^{-1} dz = 0.$$

Proof. Put $\mathbf{a} = \pi(x_0)$. Let U^* be a neighborhood of x_0 such that $V = \pi(U^*)$ is a neighborhood of \mathbf{a} as in §1.8. We may assume that C is contained in U^* by taking it sufficiently close to x_0 . Take an element σ of $SL_2(\mathbb{R})$ so that $\sigma x_0 = \infty$. Then we see

$$(2.4.1) \quad \int_C d \log f = \int_C d \log (f(z)j(\sigma, z)^k) - k \int_C d \log j(\sigma, z).$$

We may regard $f(z)j(\sigma, z)^k = (f|_k \sigma^{-1})(\sigma z)$ as a function on V (cf. (2.1.13)) which has neither a zero nor a pole at \mathbf{a} . Thus the first term of the right-hand side

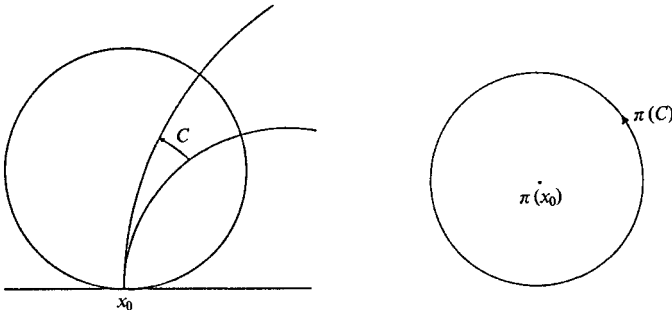

Fig. 2.4.1

converges to 0 as C goes to x_0 . To calculate the second term, put $w = \sigma z$ and $\sigma^{-1} = \begin{bmatrix} a & b \\ c & d \end{bmatrix}$. Then

$$\begin{aligned} \int_C d \log j(\sigma, z) &= - \int_{\sigma(C)} d \log j(\sigma^{-1}, w) \\ &= - \int_{w_0}^{w_0+h} d \log(cw + d) \\ &= - \log \left| \frac{cw_0 + d + ch}{cw_0 + d} \right| - i \arg \left(\frac{cw_0 + d + ch}{cw_0 + d} \right), \end{aligned}$$

where w_0 and $w_0 + h$ ($h > 0$) are the initial point and the terminal point of $\sigma(C)$, respectively. We note that h is independent of the choice of C . Let C go to x_0 . Then $\sigma(C)$ converges to ∞ , and so does w_0 . Hence the second term of the right-hand side of (2.4.1) converges to 0, so that

$$\lim \int_C d \log f = 0.$$

Similarly, since we have, by (2.1.2) and (2.1.3),

$$\left| \int_C y^{-1} dz \right| \leq \int_{\sigma(C)} \operatorname{Im}(w)^{-1} |dw|,$$

and $\sigma(C)$ tends to ∞ as $C \rightarrow x_0$, we get

$$\lim \int_C y^{-1} dz = 0. \quad \square$$

Theorem 2.4.3. *Let Γ be a Fuchsian group and g the genus of the Riemann surface \mathfrak{R}_Γ . Then we have*

$$\frac{1}{2\pi} v(\Gamma \backslash \mathbf{H}^*) = 2g - 2 + \sum_{a \in \mathfrak{R}_\Gamma} (1 - 1/e_a).$$

Here e_a denotes the ramification index of $a \in \mathfrak{R}_\Gamma$, and we understand $1/e_a = 0$ if a is a cusp.

Proof. Take an integer m and a nonzero element f of $\mathcal{A}_{2m}(\Gamma)$ as in Lemma 2.4.1. Then f has neither a zero nor a pole at every elliptic point and every cusp of Γ . Since \mathfrak{R}_Γ is a compact real manifold of dimension 2, there exist curves L_μ ($1 \leq \mu \leq l$) such that $\mathfrak{R}_\Gamma - \bigcup_{\mu=1}^l L_\mu$ is simply connected. We may assume that no cusps lie on L_μ . Taking a point b on $\bigcup_{\mu=1}^l L_\mu$, we connect elliptic points and cusps with b in $\mathfrak{R}_\Gamma - \bigcup_{\mu=1}^l L_\mu$ by curves L_ν ($l+1 \leq \nu \leq t$) which do not intersect each other (see Figure 2.4.2). We can take L_ν ($l+1 \leq \nu \leq t$) so that neither zeros nor poles of f lie on it. Now there exists an open connected subset U in \mathbf{H} which is homeomorphic to $\mathfrak{R}_\Gamma - \bigcup_{\mu=1}^l L_\mu$. In fact, take a point c on $\mathfrak{R}_\Gamma - \bigcup_{\mu=1}^l L_\mu$, and let z_0 be a point of \mathbf{H} such that $\pi(z_0) = c$. Let \mathbf{M} be the set of the curves C on \mathbf{H} which have the initial point z_0 and are mapped bijectively into $\mathfrak{R}_\Gamma - \bigcup_{\mu=1}^l L_\mu$ by π .

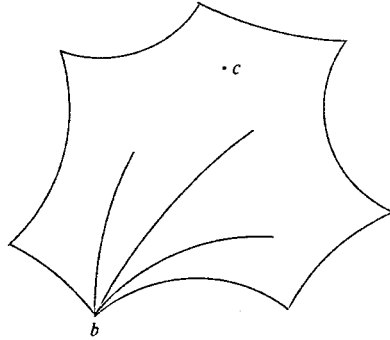

Fig. 2.4.2

Then the set U consisting of the terminal points of curves $C \in M$ is the desired one. Put $F = \bar{U}$, then it is a fundamental domain of Γ . Let x_1, \dots, x_r be the apices of F which are cusps of Γ . Let $C_v (1 \leq v \leq r)$ be a curve contained in a neighborhood of x_v whose image $\pi(C_v)$ by π is a circle around $\pi(x_v)$ oriented counterclockwise. Let M be the compact set surrounded by the boundary of F and the curves $C_v (1 \leq v \leq r)$ (see Figure 2.4.3). By the definition of the measure of $\Gamma \backslash \mathbf{H}^*$, we have

$$v(\Gamma \backslash \mathbf{H}^*) = v(F) = \lim_{\substack{C_v \rightarrow x_v \\ 1 \leq v \leq r}} \int_M \frac{dx \wedge dy}{y^2} \quad (z = x + iy).$$

By the Stokes theorem, we see

$$\int_M \frac{dx \wedge dy}{y^2} = \int_{\partial M} \frac{dz}{y} = \int_{\partial M} \left(\frac{dz}{y} + \frac{i}{m} d \log f \right) - \frac{i}{m} \int_{\partial M} d \log f,$$

where ∂M denotes the boundary of M oriented counterclockwise. Since $f(\gamma z) = f(z)j(\gamma, z)^{2m}$ for $\gamma \in \Gamma$, we see

$$(d \log f) \circ \gamma - d \log f = 2m d \log j(\gamma, z).$$

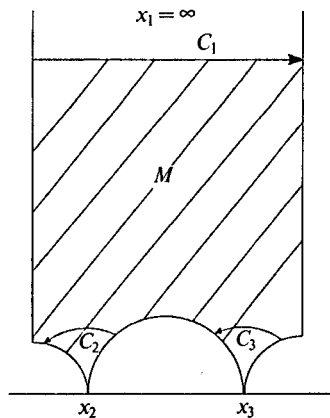

Fig. 2.4.3

This combined with Lemma 1.4.3(1) implies that $y^{-1} dz + (i/m) d \log f$ is invariant under the action of Γ . Therefore we can regard it a differential on $\Gamma \backslash \mathbf{H}^*$. By our construction of M , the boundary of M except for C_v ($1 \leq v \leq r$) consists of the pairs of the sides which are transformed by Γ and have opposite orientations. Consequently,

$$\int_{\partial M - \bigcup_v C_v} \left(\frac{dz}{y} + \frac{i}{m} d \log f \right) = 0,$$

so that

$$\int_{\partial M} \left(\frac{dz}{y} + \frac{i}{m} d \log f \right) = - \sum_{v=1}^r \int_{C_v} \left(\frac{dz}{y} + \frac{i}{m} d \log f \right).$$

By Lemma 2.4.2, the right-hand side converges to 0 as C_v 's go to x_v for all x_v . Moreover, when C_v is sufficiently close to x_v , we may consider that both zeros and poles of f are contained inside of M . Therefore we get

$$- \frac{i}{m} \int_{\partial M} d \log f = \frac{2\pi}{m} \deg(\operatorname{div}(f)).$$

This combined with Theorem 2.3.3 implies the assertion. □

§2.5. Dimensions of $\mathcal{G}_k(\Gamma)$ and $\mathcal{S}_k(\Gamma)$

We are going to calculate dimensions of $\mathcal{G}_k(\Gamma)$ and $\mathcal{S}_k(\Gamma)$ using the Riemann-Roch theorem. We assume $-1 \notin \Gamma$ if k is odd. For any real number x , $[x]$ denotes the largest integer $\leq x$. For an element $\mathbf{a} = \sum_a c_a \mathbf{a}$ of $\operatorname{Div}(\mathfrak{R}_\Gamma)_\mathbb{Q}$, put

$$[\mathbf{a}] = \sum_a [c_a] \mathbf{a}.$$

Let $\mathbf{b}_1, \dots, \mathbf{b}_t$ be all the cusps of \mathfrak{R}_Γ . When k is odd, we take $\mathbf{b}_1, \dots, \mathbf{b}_t$ so that $\mathbf{b}_1, \dots, \mathbf{b}_u$ are regular and $\mathbf{b}_{u+1}, \dots, \mathbf{b}_t$ are irregular. Let f_0 be a nonzero element of $\mathcal{A}_k(\Gamma)$. (The existence of such a form was proved in Theorem 2.3.1 for even k , and will be proved for odd k in Theorem 2.6.8.) Then we have the following

Lemma 2.5.1. *With the above notation, the following isomorphisms hold as vector spaces over \mathbb{C} .*

- (1) $\mathcal{G}_k(\Gamma) \simeq L([\operatorname{div}(f_0)])$.
- (2) $\mathcal{S}_k(\Gamma) \simeq \begin{cases} L\left(\left[\operatorname{div}(f_0) - \sum_{v=1}^t \mathbf{b}_v\right]\right) & (k: \text{even}), \\ L\left(\left[\operatorname{div}(f_0) - \sum_{v=1}^u \mathbf{b}_v - \frac{1}{2} \sum_{v=u+1}^t \mathbf{b}_v\right]\right) & (k: \text{odd}). \end{cases}$

Proof. Since

$$\mathcal{A}_k(\Gamma) = \{ff_0 \mid f \in \mathcal{A}_0(\Gamma)\},$$

we see, by definition,

$$\begin{aligned} \mathcal{G}_k(\Gamma) &= \{ff_0 \mid f \in \mathcal{A}_0(\Gamma), f = 0 \text{ or } \operatorname{div}(ff_0) \geq 0\} \\ &\simeq \{f \in \mathcal{A}_0(\Gamma) \mid f = 0 \text{ or } \operatorname{div}(f) + \operatorname{div}(f_0) \geq 0\} \\ &\simeq \{\phi \in K(\mathfrak{R}_F) \mid \phi = 0 \text{ or } \operatorname{div}(\phi) + \operatorname{div}(f_0) \geq 0\}. \end{aligned}$$

The last space is no other than $L([\operatorname{div}(f_0)])$, since $\operatorname{div}(\phi) + \operatorname{div}(f_0) \geq 0$ is equivalent to saying that $\operatorname{div}(\phi) + [\operatorname{div}(f_0)] \geq 0$. This shows (1). Next suppose ff_0 is a nonzero element of $\mathcal{G}_k(\Gamma)$. Then

$$ff_0 \in \mathcal{S}_k(\Gamma) \Leftrightarrow v_{b_v}(ff_0) > 0 \quad (1 \leq v \leq t).$$

When either k is even, or k is odd and $1 \leq v \leq u$, we see

$$\begin{aligned} v_{b_v}(ff_0) > 0 &\Leftrightarrow v_{b_v}(ff_0) \geq 1 \\ &\Leftrightarrow v_{b_v}(f) + v_{b_v}(f_0) - 1 \geq 0. \end{aligned}$$

When k is odd and $u + 1 \leq v \leq t$, we get

$$\begin{aligned} v_{b_v}(ff_0) > 0 &\Leftrightarrow v_{b_v}(ff_0) \geq 1/2 \\ &\Leftrightarrow v_{b_v}(f) + v_{b_v}(f_0) - 1/2 \geq 0. \end{aligned}$$

Therefore a similar argument as above shows (2). \square

We are going to calculate dimensions of the spaces in Lemma 2.5.1. Let a_1, \dots, a_r be all elliptic points of \mathfrak{R}_F , and e_μ the ramification index of a_μ ($1 \leq \mu \leq r$). Put

$$d = 2g - 2 + \sum_{\mu=1}^r (1 - 1/e_\mu) + t$$

with genus g of \mathfrak{R}_F . We note that for any nonzero element $h(z)$ of $\mathcal{A}_k(\Gamma)$, $\deg(\operatorname{div}(h)) = kd/2$ and $d = (2\pi)^{-1}v(\Gamma \setminus \mathbf{H}^*) > 0$ by Theorem 2.4.3.

1° Suppose $k < 0$. Since

$$\deg([\operatorname{div}(f_0)]) \leq \deg(\operatorname{div}(f_0)) = kd/2 < 0,$$

we get

$$\dim \mathcal{G}_k(\Gamma) = \dim \mathcal{S}_k(\Gamma) = 0.$$

2° Let $k = 0$. Then f_0 can be considered as an element of $K(\mathfrak{R}_F)^\times$, and therefore

$$\dim \mathcal{G}_0(\Gamma) = l(\operatorname{div}(f_0)) = 1,$$

and

$$\dim \mathcal{S}_0(\Gamma) = l\left(\operatorname{div}(f_0) - \sum_{v=1}^t b_v\right) = \begin{cases} 1 & \text{if } t = 0, \\ 0 & \text{if } t \geq 1. \end{cases}$$

3° Assume $k \geq 3$ and put

$$\mathbf{a} = \begin{cases} \left[\operatorname{div}(f_0) - \sum_{v=1}^t \mathbf{b}_v \right] & (k: \text{even}), \\ \left[\operatorname{div}(f_0) - \sum_{v=1}^u \mathbf{b}_v - \frac{1}{2} \sum_{v=u+1}^t \mathbf{b}_v \right] & (k: \text{odd}). \end{cases}$$

By Theorem 2.3.3 and Theorem 2.3.5, we see

$$\mathbf{a} = \begin{cases} \operatorname{div}(\omega(f_0)) + \sum_{\mu=1}^r \left[\frac{k}{2} (1 - 1/e_\mu) \right] \mathbf{a}_\mu + \sum_{v=1}^t \frac{k-2}{2} \mathbf{b}_v & (k: \text{even}), \\ \frac{1}{2} \operatorname{div}(\omega(f_0^2)) + \sum_{\mu=1}^r \left[\frac{k}{2} (1 - 1/e_\mu) \right] \mathbf{a}_\mu + \sum_{v=1}^u \frac{k-2}{2} \mathbf{b}_v + \sum_{v=u+1}^t \frac{k-1}{2} \mathbf{b}_v & (k: \text{odd}), \end{cases}$$

and therefore,

$$\deg(\mathbf{a}) = \begin{cases} \frac{k}{2} (2g-2) + \sum_{\mu=1}^r \left[\frac{k}{2} (1 - 1/e_\mu) \right] + \frac{k-2}{2} t & (k: \text{even}), \\ \frac{k}{2} (2g-2) + \sum_{\mu=1}^r \left[\frac{k}{2} (1 - 1/e_\mu) \right] + \frac{k-2}{2} u + \frac{k-1}{2} (t-u) & (k: \text{odd}). \end{cases}$$

In particular,

$$\deg(\mathbf{a}) \geq \frac{k}{2} (2g-2) + \sum_{\mu=1}^r \left[\frac{k}{2} (1 - 1/e_\mu) \right] + \frac{k-2}{2} t.$$

Since $\frac{k}{2}(e_\mu - 1)$ is integral,

$$\left[\frac{k}{2} (1 - 1/e_\mu) \right] \geq \frac{k-2}{2} (1 - 1/e_\mu),$$

so that

$$\begin{aligned} \deg(\mathbf{a}) - (2g-2) &\geq \frac{k-2}{2} \left\{ (2g-2) + \sum_{\mu=1}^r (1 - 1/e_\mu) + t \right\} \\ &= \frac{k-2}{2} d > 0. \end{aligned}$$

Since $\deg(\mathbf{a}) \leq \deg([\operatorname{div}(f_0)])$, we get

$$\deg([\operatorname{div}(f_0)]) > (2g-2).$$

By Lemma 2.5.1 and Corollary 2.2.2(3), we obtain

$$\dim \mathcal{G}_k(\Gamma) = \deg[\operatorname{div}(f_0)] - g + 1,$$

$$\dim \mathcal{S}_k(\Gamma) = \deg(\mathbf{a}) - g + 1.$$

Since $\deg([\operatorname{div}(f_0)]) - \deg(\mathbf{a})$ is equal to t if k is even, or equal to u if k is odd, we see

$$\dim \mathcal{G}_k(\Gamma) - \dim \mathcal{S}_k(\Gamma) = \begin{cases} t & (k:\text{even}), \\ u & (k:\text{odd}). \end{cases}$$

4° Let $k = 2$. Since $\mathcal{S}_2(\Gamma) \simeq D_0^1(\mathfrak{R}_\Gamma)$, we obtain by (2.2.14) that

$$\dim \mathcal{S}_2(\Gamma) = g.$$

Since $[\operatorname{div}(f_0)] = \operatorname{div}(\omega(f_0)) + \sum_{v=1}^t \mathbf{b}_v$, we have by (2.2.12) and (2.2.13) that

$$l(\operatorname{div}(\omega(f_0)) - [\operatorname{div}(f_0)]) = l\left(-\sum_{v=1}^t \mathbf{b}_v\right) = \begin{cases} 0 & (t > 0), \\ 1 & (t = 0). \end{cases}$$

By Theorem 2.2.1, we get

$$\dim \mathcal{G}_2(\Gamma) = l([\operatorname{div}(f_0)]) = \begin{cases} g + t - 1 & (t > 0), \\ g & (t = 0). \end{cases}$$

5° When $k = 1$, we have by Theorem 2.2.1

$$l([\operatorname{div}(f_0)]) - l(\operatorname{div}(\omega(f_0^2)) - [\operatorname{div}(f_0)]) = \deg([\operatorname{div}(f_0)]) - g + 1.$$

Since by Theorem 2.3.5,

$$L(\operatorname{div}(\omega(f_0^2)) - [\operatorname{div}(f_0)]) = L\left(\left[\operatorname{div}(f_0) - \sum_{v=1}^u \mathbf{b}_v - \frac{1}{2} \sum_{v=u+1}^t \mathbf{b}_v\right]\right) \simeq \mathcal{S}_1(\Gamma),$$

and

$$\begin{aligned} \deg([\operatorname{div}(f_0)]) &= \deg(\operatorname{div}(f_0)) - \frac{1}{2} \sum_{\mu=1}^r (1 - 1/e_\mu) - (t - u)/2 \\ &= g - 1 + u/2, \end{aligned}$$

we obtain

$$\dim \mathcal{G}_1(\Gamma) - \dim \mathcal{S}_1(\Gamma) = u/2.$$

We note that general calculation of dimensions of $\mathcal{G}_1(\Gamma)$ and $\mathcal{S}_1(\Gamma)$ is an open problem.

Summing up all together, we obtain the following

Theorem 2.5.2. *Let k be an even integer, g the genus of \mathfrak{R}_Γ , e_1, \dots, e_r the orders of inequivalent elliptic points of Γ , and t the number of the inequivalent cusps of Γ . Then*

$$\dim \mathcal{S}_k(\Gamma) = \begin{cases} (k-1)(g-1) + \sum_{\mu=1}^r \left[\frac{k}{2}(1-1/e_\mu) \right] + \left(\frac{k}{2} - 1 \right) t & (k > 2), \\ g & (k = 2), \\ 1 & (k = 0, t = 0), \\ 0 & (k = 0, t > 0), \\ 0 & (k < 0), \end{cases}$$

$$\dim \mathcal{G}_k(\Gamma) = \begin{cases} \dim \mathcal{S}_k(\Gamma) + t & (k \geq 4), \\ \dim \mathcal{S}_2(\Gamma) + t - 1 \quad (= g + t - 1) & (k = 2, t > 0), \\ \dim \mathcal{S}_2(\Gamma) \quad (= g) & (k = 2, t = 0), \\ 1 & (k = 0), \\ 0 & (k < 0). \end{cases}$$

Theorem 2.5.3. *Let k be an odd integer, and assume $-1 \notin \Gamma$. Let g and $\{e_\mu\}_{\mu=1}^r$ be the same as in Theorem 2.5.2. Further let u and v be the numbers of the inequivalent regular and irregular cusps of Γ , respectively. Then*

$$\dim \mathcal{S}_k(\Gamma) = \begin{cases} (k-1)(g-1) + \sum_{\mu=1}^r \left[\frac{k}{2}(1-1/e_\mu) \right] + \frac{k-2}{2}u + \frac{k-1}{2}v & (k \geq 3), \\ 0 & (k < 0), \end{cases}$$

$$\dim \mathcal{G}_k(\Gamma) = \begin{cases} \dim \mathcal{S}_k(\Gamma) + u & (k \geq 3), \\ \dim \mathcal{S}_1(\Gamma) + u/2 & (k = 1), \\ 0 & (k < 0). \end{cases}$$

§2.6. Poincaré Series and Eisenstein Series

We are going to construct automorphic forms called Poincaré series.

Theorem 2.6.1. *Let z_0 be a point of \mathbf{H} and δ a positive real number such that the set $M = \{z \in \mathbf{C} \mid |z - z_0| \leq 3\delta\}$ is included in \mathbf{H} . For any real numbers k and $p \geq 1$, there exists a constant C satisfying*

$$|f(z_1)| \leq C \left(\int_M |f(z) \operatorname{Im}(z)^{k/2}|^p dv(z) \right)^{1/p} \quad (|z_1 - z_0| \leq \delta)$$

for any continuous function $f(z)$ on M which is holomorphic on the interior of M .

Proof. Let $f(z) = \sum_{n=0}^{\infty} a_n(z - z_1)^n$ be the Taylor expansion of $f(z)$ at z_1 . Since

$$\int_{|z-z_1| \leq \delta} f(z) dx dy = \int_0^{2\pi} \int_0^\delta \sum_{n=0}^{\infty} a_n r^{n+1} e^{in\theta} dr d\theta = \pi \delta^2 a_0,$$

we see

$$\begin{aligned} |f(z_1)| &\leq (\pi \delta^2)^{-1} \int_M |f(z)| dx dy \\ &\leq (\pi \delta^2 C_1)^{-1} \int_M |f(z) \operatorname{Im}(z)^{k/2}| dv(z) \end{aligned}$$

with $C_1 = \inf \{ \text{Im}(z)^{k/2-2} | z \in M \}$. By Hölder's inequality, we get

$$(2.6.1) \quad |f(z_1)| \leq (\pi\delta^2 C_1)^{-1} \left(\int_M dv(z) \right)^{1/q} \left(\int_M |f(z) \text{Im}(z)^{k/2}|^p dv(z) \right)^{1/p}$$

with q such that $1 < q \leq \infty$ and $1/p + 1/q = 1$. Thus, it is sufficient to put $C = (\pi\delta^2 C_1)^{-1} \left(\int_M dv(z) \right)^{1/q}$. \square

From the above theorem we easily get the following

Corollary 2.6.2. *Let k, p be the same as in Theorem 2.6.1. For an open subset U of \mathbf{H} and a point z_0 of U , there exists a constant C such that*

$$|f(z_0)| \leq C \left(\int_U |f(z) \text{Im}(z)^{k/2}|^p dv(z) \right)^{1/p}$$

for any holomorphic function $f(z)$ on U .

The following theorem will be used in Chapter 6.

Theorem 2.6.3. *Let k, p be the same as in Theorem 2.6.1. Assume that $f(z)$ is holomorphic on \mathbf{H} and $\int_{\mathbf{H}} |f(z) \text{Im}(z)^{k/2}|^p dv(z) < \infty$. Then, for any real number a, b such that $0 < a < b$,*

$$\lim_{|x| \rightarrow \infty} |f(z)| = 0$$

uniformly with respect to y on the interval $[a, b]$, where $z = x + iy$.

Proof. Take a real number δ so that $0 < 2\delta < a$, and put for a positive integer n

$$U_n = \{ z \in \mathbf{H} | a - 2\delta \leq \text{Im}(z) \leq b + 2\delta,$$

$$n - 2\delta \leq \text{Re}(z) \leq n + 1 + 2\delta \},$$

$$V_n = \{ z \in \mathbf{H} | a \leq \text{Im}(z) \leq b, \quad n \leq \text{Re}(z) \leq n + 1 \}.$$

Let $z_0 \in V_n$, then $\{ z \in \mathbf{C} | |z - z_0| \leq 2\delta \} \subset U_n$. Therefore by (2.6.1),

$$|f(z_0)| \leq (\pi\delta^2 C_1)^{-1} v(U_n)^{1/q} \left(\int_{U_n} |f(z) \text{Im}(z)^{k/2}|^p dv(z) \right)^{1/p}$$

with q such that $1 < q \leq \infty$, $1/p + 1/q = 1$, and a constant C_1 . Since the measure $v(U_n)$ is independent of n , and

$$\lim_{n \rightarrow \infty} \int_{U_n} |f(z) \text{Im}(z)^{k/2}|^p dv(z) = 0$$

by assumption, we obtain

$$\lim_{|x_0| \rightarrow \infty} |f(z_0)| = 0 \quad (z_0 = x_0 + iy_0)$$

uniformly with respect to y_0 on $[a, b]$. \square

Corollary 2.6.4. *Let k, p be the same as in Theorem 2.6.1, and U a subdomain of \mathbf{H} . For a holomorphic function $f(z)$ on U , we put*

$$\|f\|_U = \left(\int_U |f(z)| \operatorname{Im}(z)^{k/2} |p| dv(z) \right)^{1/p}.$$

If a sequence $\{f_n(z)\}$ of holomorphic functions on U satisfies Cauchy's condition with respect to the norm $\|\cdot\|_U$, then $\{f_n(z)\}$ converges to a holomorphic function on U uniformly on any compact subset of U .

Proof. By Corollary 2.6.2, for any point z of U , a sequence $\{f_n(z)\}$ of complex numbers is a Cauchy sequence. Then we can define $f(z) = \lim_{n \rightarrow \infty} f_n(z)$. For any point z_0 of U , take $\delta > 0$ so that $\{z \in \mathbb{C} \mid |z - z_0| \leq 2\delta\} \subset U$. By Theorem 2.6.1, there exists a constant C such that

$$|f_n(z) - f_m(z)| \leq C \|f_n - f_m\|_U$$

for any z satisfying $|z - z_0| \leq \delta$. For any $\varepsilon > 0$, take an integer N so that $\|f_n - f_m\|_U < \varepsilon/2C$ if $m, n > N$. For z satisfying $|z - z_0| \leq \delta$, take an integer $n(z) > N$ so that $|f(z) - f_{n(z)}(z)| < \varepsilon/2$. Then we see

$$|f(z) - f_n(z)| \leq |f(z) - f_{n(z)}(z)| + |f_{n(z)}(z) - f_n(z)| < \varepsilon$$

for any $n > N$ and any z satisfying $|z - z_0| \leq \delta$. Thus f_n converges to f uniformly on $|z - z_0| \leq \delta$. This implies $\{f_n\}$ converges to f uniformly on any compact subset of U , and therefore, f is holomorphic on U . \square

Lemma 2.6.5. *Let $\{f_n(z)\}$ be a sequence of holomorphic functions on a domain D of \mathbb{C} . Let z_0 be a point of D . If $f_n(z)$ converges uniformly on any compact subset of $D - \{z_0\}$, then so does it uniformly on any compact subset of D .*

Proof. We have only to see that it converges uniformly on some neighborhood of z_0 . Take a positive number r so small that $\{z \in \mathbb{C} \mid |z - z_0| < r\} \subset D$. Then

$$f_n(z) = \frac{1}{2\pi i} \int_{|\zeta - z_0| = r} \frac{f_n(\zeta)}{\zeta - z} d\zeta \quad (|z - z_0| < r).$$

Since $f_n(\zeta)$ converges uniformly on $|\zeta - z_0| = r$, $f_n(z)$ also converges uniformly on $\{z \in \mathbb{C} \mid |z - z_0| < r/2\}$. \square

Let Γ be a Fuchsian group, χ a character of Γ of finite order, and k an integer. We suppose $\chi(-1) = (-1)^k$ if $-1 \in \Gamma$. Let A be a subgroup of Γ , and $\phi(z)$ a meromorphic function of \mathbf{H} satisfying the following conditions:

- (i) $\phi|_k \lambda = \chi(\lambda)\phi$ for any $\lambda \in A$;
- (ii) the number of A -inequivalent poles of $\phi(z)$ is finite;

(iii) let z_1, \dots, z_m be all A -inequivalent poles of $\phi(z)$, and x_1, \dots, x_r all Γ -inequivalent cusps of Γ . Then, for any neighborhoods U_μ of z_μ and V_ν of x_ν ,

$$\int_{A \setminus \mathbf{H}'} |\phi(z)| \operatorname{Im}(z)^{k/2} dv(z) < \infty,$$

where $\mathbf{H}' = \mathbf{H} - \bigcup_{\mu=1}^m \bigcup_{\lambda \in A} \lambda U_\mu - \bigcup_{\nu=1}^r \bigcup_{\gamma \in \Gamma} \gamma V_\nu$.

For such a function $\phi(z)$, we define

$$(2.6.2) \quad F(z) = F_k(z; \phi, \chi, A, \Gamma) = \sum_{\gamma \in A \backslash \Gamma} \overline{\chi(\gamma)} (\phi|_k \gamma)(z) \quad (z \in \mathbf{H}).$$

It is obvious by the definition of the series and condition (i) that if $F(z)$ is convergent, then it is independent of the choice of the representatives of $A \backslash \Gamma$, and

$$F|_k \gamma = \chi(\gamma) F \quad \text{for any } \gamma \in \Gamma.$$

We call this series the *Poincaré series*.

Theorem 2.6.6. *Under the same notation and assumptions as above, we have:*

- (1) $F(z)$ is convergent absolutely and uniformly on any compact subset of $\mathbf{H} - \{\gamma z_\mu | \gamma \in \Gamma, 1 \leq \mu \leq m\}$, and $F(z)$ belongs to $\Omega_k(\Gamma, \chi)$;
- (2) if $\phi(z)$ has a pole at $w \in \mathbf{H}$ and is holomorphic at γw for all $\gamma \in \Gamma - \{\pm 1\} \cdot A$, then $F(z)$ has also a pole at w and its order is equal to that of $\phi(z)$.

Proof. Let z_0 be any element of $\mathbf{H} - \{\gamma z_\mu | \gamma \in \Gamma, 1 \leq \mu \leq m\}$. Take U_μ, V_ν and a neighborhood W of z_0 so that

$$(2.6.3) \quad \gamma W \cap U_\mu = \emptyset, \quad \gamma W \cap V_\nu = \emptyset \quad (\gamma \in \Gamma, 1 \leq \mu \leq m, 1 \leq \nu \leq r),$$

$$(2.6.4) \quad \{\gamma \in \Gamma | \gamma W \cap W \neq \emptyset\} = \Gamma_{z_0}.$$

Then

$$(2.6.5) \quad \int_W \sum_{\gamma \in A \backslash \Gamma} |(\phi|_k \gamma)(z)| \operatorname{Im}(z)^{k/2} dv(z) = \sum_{\gamma \in A \backslash \Gamma} \int_W |\phi(\gamma z)| \operatorname{Im}(\gamma z)^{k/2} dv(z) \\ = \sum_{\gamma \in A \backslash \Gamma} \int_{\gamma W} |\phi(z)| \operatorname{Im}(z)^{k/2} dv(z).$$

We see that $\gamma W \subset \mathbf{H}'$ by (2.6.3), and for an element γ_1 of Γ , (2.6.4) implies

$$|A \backslash \{\gamma \in \Gamma | \lambda \gamma W \cap \gamma_1 W \neq \emptyset \text{ for some } \lambda \in A\}| \leq |A \backslash A \gamma_1 \Gamma_{z_0}| \\ \leq |\Gamma_{z_0}|.$$

Therefore,

$$\leq |\Gamma_{z_0}| \int_{A \backslash \mathbf{H}'} |\phi(z)| \operatorname{Im}(z)^{k/2} dv(z) < \infty.$$

Applying Corollary 2.6.4 for $p = 1$, we see that $F(z)$ is convergent uniformly on any compact subset of W , and is holomorphic on W . This implies $F(z)$ is holomorphic on $\mathbf{H} - \{\gamma z_\mu | \gamma \in \Gamma, 1 \leq \mu \leq m\}$. Next put $z' = \gamma_1 z_1$ with $\gamma_1 \in \Gamma$ and

$$\Gamma_0 = \{\gamma \in \Gamma | \phi(z) \text{ has a pole at } \gamma z'\}.$$

Then $\gamma_1^{-1} \Gamma_{z'} \subset \Gamma_0$, $A \gamma_1^{-1} \subset \Gamma_0$, and $|A \backslash \Gamma_0 / \Gamma_{z'}| \leq m$. Write

$$F(z) = \Sigma_1 \overline{\chi(\gamma)} (\phi|_k \gamma)(z) + \Sigma_2 \overline{\chi(\gamma)} (\phi|_k \gamma)(z),$$

where Σ_1 is the summation taken over the representatives γ such that $A\gamma \in \Gamma_0$, and Σ_2 is the summation over the rest. Then we see by a similar argument as above that Σ_1 is a finite sum, and by Lemma 2.6.5 Σ_2 -part is holomorphic on $\gamma_1 U_1$. Therefore $F(z)$ is holomorphic on $\gamma_1 U_1 - \{z'\}$ and has at most a pole at z' . Since this also holds for z_2, \dots, z_m , $F(z)$ is a meromorphic function on \mathbf{H} . The automorphy of $F(z)$ has already been proved. Therefore the first assertion is proved. Next assume that $w = z_1 = z'$ satisfies the condition of (2). Then $\Gamma_0 = A \cdot Z(\Gamma)$ and $\Sigma_1 \overline{\chi(\gamma)}(\phi|_k \gamma)(z) = c\phi(z)$ with $c = |Z(\Gamma)|/|Z(A)|$. Therefore $F(z)$ has a pole at w and the orders of poles of F and ϕ at w are equal. \square

We are going to give some sufficient conditions for $\phi(z)$ under which $F(z)$ is holomorphic at a cusp. Let x be a cusp of Γ and σ an element of $SL_2(\mathbb{R})$ such that $\sigma x = \infty$. We impose the following two additional conditions:

(iv) if x is not a cusp of A , then there exist positive numbers M, l and ε such that

$$|(\phi|_k \sigma^{-1})(z)| \leq M|z|^{-1-\varepsilon} \quad (\text{Im}(z) > l);$$

(v) if x is a cusp of A , then there exist $M, l (> 0)$ and $\varepsilon (\geq 0)$ satisfying

$$|(\phi|_k \sigma^{-1})(z)| \leq M|z|^{-\varepsilon} \quad (\text{Im}(z) > l).$$

Theorem 2.6.7. Assume that $\Gamma, A, \phi(z)$ satisfy the foregoing conditions (i) through (iii). Let x_0 be a cusp of Γ . If conditions (iv) and (v) are satisfied for every cusp x which is Γ -equivalent to x_0 , then $F(z)$ is holomorphic at x_0 . Moreover, if we can take ε in (v) positive for all x which are Γ -equivalent to x_0 , then $F(z)$ has a zero at x_0 .

Proof. First we note that conditions (iv) and (v) are independent of the choice of σ . (M, l, ε depend of course on the choice of σ .) Let $\{\alpha\}$ be a complete set of representatives of $A \setminus \Gamma / \Gamma_{x_0}$. For each α , let $\{\beta\}$ be a complete set of representatives of $(\alpha^{-1} A \alpha \cap \Gamma_{x_0}) \setminus \Gamma_{x_0}$. Then $\Gamma = \coprod_{\alpha, \beta} A \alpha \beta$. Put

$$\phi_\alpha(z) = \sum_{\beta} \overline{\chi(\alpha\beta)}(\phi|_k \alpha\beta)(z).$$

Then

$$(2.6.6) \quad F(z) = \sum_{\alpha} \sum_{\beta} \overline{\chi(\alpha\beta)}(\phi|_k \alpha\beta)(z) = \sum_{\alpha} \phi_\alpha(z),$$

and

$$\phi_\alpha|_k \gamma = \chi(\gamma)\phi_\alpha \quad (\gamma \in \Gamma_{x_0}).$$

By condition (ii), there exists a neighborhood U of x_0 in \mathbf{H} such that $F(z)$ is convergent uniformly on any compact subset of U . In other words, by taking $\sigma_0 \in SL_2(\mathbb{R})$ so that $\sigma_0 x_0 = \infty$,

$$F|_k \sigma_0^{-1} = \sum_{\alpha} \phi_\alpha|_k \sigma_0^{-1}$$

is convergent uniformly on any compact subset of the domain $\{z \in \mathbf{H} | \text{Im}(z) > b\}$ for some positive number b . Thus it is sufficient to show that $\phi_\alpha|_k \sigma_0^{-1}$ is holomorphic at ∞ , and moreover, has a zero at ∞ if $\varepsilon > 0$.

1° Assume that αx_0 is not a cusp of Λ . Since $\alpha^{-1}\Lambda\alpha \cap \Gamma_{x_0}$ coincides with $\{1\}$ or $\{\pm 1\}$, we have

$$\phi_\alpha|_k\sigma_0^{-1} = C \cdot \sum_{\beta \in \Gamma_{x_0}} \overline{\chi(\alpha\beta)} (\phi|_k\alpha\sigma_0^{-1}\sigma_0\beta\sigma_0^{-1})$$

with $C = 1$ or $1/2$, respectively. Applying condition (iv) for $x = \alpha x_0$, $\sigma = \sigma_0\alpha^{-1}$, we take $M, l, \varepsilon (> 0)$ so that

$$|(\phi|_k\alpha\sigma_0^{-1})(z)| \leq M|z|^{-1-\varepsilon} \quad (\text{Im}(z) > l),$$

so that

$$|(\phi_\alpha|_k\sigma_0^{-1})(z)| \leq 2M \sum_{m \in \mathbb{Z}} |z + mh|^{-1-\varepsilon} \quad (\text{Im}(z) > l),$$

where h is a positive number such that $\sigma_0\Gamma_{x_0}\sigma_0^{-1} \cdot \{\pm 1\} = \left\{ \pm \begin{bmatrix} 1 & h \\ 0 & 1 \end{bmatrix}^m \mid m \in \mathbb{Z} \right\}$.

Comparing the series on the right-hand side with the series $\sum m^{-1-\varepsilon}$, we see it is convergent uniformly on any compact subset of the domain $\text{Im}(z) > l$, so that $\phi_\alpha|_k\sigma_0^{-1}$ is holomorphic at ∞ . Moreover if z tends to ∞ along the imaginary axis, $(\phi_\alpha|_k\sigma_0^{-1})(z)$ does to 0; namely, $\phi_\alpha|_k\sigma_0^{-1}$ has a zero at ∞ .

2° Suppose αx_0 is a cusp of Λ . Then $\alpha^{-1}\Lambda\alpha \cap \Gamma_{x_0}$ is a subgroup of Γ_{x_0} of finite index, so that the summation \sum_β is a finite sum and

$$\phi_\alpha|_k\sigma_0^{-1} = \sum_\beta \overline{\chi(\alpha\beta)} (\phi|_k\alpha\sigma_0^{-1}\sigma_0\beta\sigma_0^{-1}).$$

From condition (v) for $x = \alpha x_0$, $\sigma = \sigma_0\alpha^{-1}$, there exist M, l, ε such that

$$(2.6.7) \quad |(\phi|_k\alpha\sigma_0^{-1})(z)| \leq M|z|^{-\varepsilon} \leq M \quad (\text{Im}(z) > l).$$

Noting that $\sigma_0\beta\sigma_0^{-1} = \pm \begin{bmatrix} 1 & mh \\ 0 & 1 \end{bmatrix}$ for some integer m , we see that $\phi_\alpha|_k\sigma_0^{-1}$ is holomorphic at ∞ . If $\varepsilon > 0$, then we see from (2.6.7) that $\phi_\alpha|_k\sigma_0^{-1}$ has a zero at ∞ . \square

We can prove the existence of nonzero automorphic forms using the Poincaré series. Here we prove that if $\Gamma \not\cong -1$, then $\mathcal{A}_k(\Gamma) \neq \{0\}$ for any odd integer k .

Theorem 2.6.8. *If $\Gamma \not\cong -1$, then $\mathcal{A}_k(\Gamma) \neq \{0\}$ for any odd integer k .*

Proof. Let z_0 be a nonelliptic point of \mathbf{H} and put $\phi(z) = (z - z_0)^{-2}$. Since $\phi(z)$ satisfies conditions (i) through (v) for $k=3$ and $\Lambda = \{1\}$, the Poincaré series

$$F(z) = \sum_{\gamma \in \Gamma} (\phi|_k\gamma)(z)$$

belongs to $\mathcal{A}_3(\Gamma)$. Theorem 2.6.6(2) implies that $F(z)$ does not vanish identically since $F(z)$ has a pole of order 2 at z_0 . Thus $\mathcal{A}_3(\Gamma) \neq \{0\}$. Next let k be any odd integer. Take the integer n so that $k - 2n = 3$, then we obtain

$$\mathcal{A}_k(\Gamma) = \mathcal{A}_3(\Gamma) \mathcal{A}_{2n}(\Gamma) \neq \{0\}. \quad \square$$

When Γ has cusps, Poincaré series yield one of basic methods to construct automorphic forms of weight $k \geq 3$. Let χ be a character of Γ of finite order. Let x be a cusp of Γ , and σ an element of $SL_2(\mathbb{R})$ such that $\sigma x = \infty$. We assume

$$(2.6.8) \quad \chi(\gamma)j(\sigma\gamma\sigma^{-1}, z)^k = 1 \quad \text{for } \gamma \in \Gamma_x.$$

This condition is independent of the choice of σ . If χ is the trivial character, k is odd and $-1 \notin \Gamma$, then (2.6.8) implies that x is a regular cusp. Let h be a positive number such that

$$\sigma\Gamma_x\sigma^{-1} \cdot \{\pm 1\} = \left\{ \pm \begin{bmatrix} 1 & h \\ 0 & 1 \end{bmatrix}^n \mid n \in \mathbb{Z} \right\}.$$

For nonnegative integer m , we put

$$(2.6.9) \quad \phi_m(z) = \phi_m(z; x, \sigma) = j(\sigma, z)^{-k} e^{2\pi im\sigma z/h}.$$

It is easy to see that $\phi_m(z)$ satisfies conditions (i) through (v) for Γ , χ and $\Lambda = \Gamma_x$. Therefore $F_k(z; \phi_m, \chi, \Gamma_x, \Gamma)$ is meaningful. If we define the character χ^σ of $\sigma\Gamma\sigma^{-1}$ by

$$(2.6.10) \quad \chi^\sigma(\sigma\gamma\sigma^{-1}) = \chi(\gamma), \quad (\gamma \in \Gamma),$$

then

$$(2.6.11) \quad F_k(z; \phi_m, \chi, \Gamma_x, \Gamma) = F_k(z; e^{2\pi imz/h}, \chi^\sigma, \sigma\Gamma_x\sigma^{-1}, \sigma\Gamma\sigma^{-1})|_k\sigma.$$

The following theorem is a direct application of Theorems 2.6.6 and 2.6.7.

Theorem 2.6.9. *Suppose $k \geq 3$. Under the same notation and assumptions as above, we have:*

(1) *If $m \geq 1$, then $F_k(z; \phi_m, \chi, \Gamma_x, \Gamma) \in \mathcal{S}_k(\Gamma, \chi)$.*

(2) *If $m = 0$, then $F(z) = F_k(z; \phi_0, \chi, \Gamma_x, \Gamma) \in \mathcal{G}_k(\Gamma, \chi)$. It has the Fourier expansion at x of the form*

$$(F|_k\sigma^{-1})(z) = 1 + \sum_{n=1}^{\infty} a_n e^{2\pi inz/h},$$

and vanishes at all cusps which are inequivalent to x .

We especially call Poincaré series $F_k(z; \phi_0, \chi, \Gamma_x, \Gamma)$ *Eisenstein series*.

Theorem 2.6.10. *Suppose $k \geq 3$. Let x be a cusp of Γ satisfying (2.6.8), and put*

$$g_k^{(m)}(z) = F_k(z; \phi_m, \chi, \Gamma_x, \Gamma) \quad (m \geq 0).$$

For an element $f(z)$ of $\mathcal{S}_k(\Gamma, \chi)$, let σ be an element of $SL_2(\mathbb{R})$ such that $\sigma x = \infty$, and

$$(f|_k\sigma^{-1})(z) = \sum_{n=1}^{\infty} a_n e^{2\pi inz/h}$$

be the Fourier expansion at x . Then

$$\int_{\Gamma \backslash \mathbb{H}} f(z) \overline{g_k^{(m)}(z)} \operatorname{Im}(z)^k dv(z) = \begin{cases} 0 & (m = 0), \\ a_m (4\pi m)^{1-k} h^k (k-2)! & (m \geq 1). \end{cases}$$

Proof. Taking $\sigma\Gamma\sigma^{-1}$ in place of Γ , we may assume that $x = \infty$ and $\sigma = 1$. We see

$$\begin{aligned}
 (2.6.12) \quad & \int_{\Gamma \backslash \mathbf{H}} |f(z)| \sum_{\gamma \in \Gamma_x \backslash \Gamma} |j(\gamma, z)|^{-k} e^{2\pi i m \gamma z / h} |\operatorname{Im}(z)|^k dv(z) \\
 &= \sum_{\gamma \in \Gamma_x \backslash \Gamma} \int_{\Gamma \backslash \mathbf{H}} |f(z)| e^{2\pi i m \gamma z / h} |j(\gamma, z)|^{-k} |\operatorname{Im}(z)|^k dv(z) \\
 &= \int_{\Gamma_x \backslash \mathbf{H}} |f(z)| e^{2\pi i m z / h} |\operatorname{Im}(z)|^k dv(z) \\
 &= \int_0^\infty \int_0^h |f(z)| e^{-2\pi m y / h} y^{k-2} dx dy.
 \end{aligned}$$

Since $|f(z)y^{k/2}|$ is bounded on \mathbf{H} , we have

$$(2.6.13) \quad |f(z)| e^{-2\pi m y / h} y^{k-2} = O(y^{k/2-2}) \quad (y \rightarrow 0).$$

Moreover, $f(z) = O(e^{-2\pi y / h})$ ($y \rightarrow \infty$) uniformly on x . Therefore the integral (2.6.13) is convergent. Thus we can exchange the order of integration and summation, so that

$$\begin{aligned}
 & \int_{\Gamma \backslash \mathbf{H}} f(z) \overline{g_k^{(m)}(z)} |\operatorname{Im}(z)|^k dv(z) \\
 &= \sum_{\gamma \in \Gamma_x \backslash \Gamma} \chi(\gamma) \int_{\Gamma \backslash \mathbf{H}} f(z) e^{-2\pi i m \gamma \bar{z} / h} |j(\gamma, \bar{z})|^{-k} |\operatorname{Im}(z)|^k dv(z) \\
 &= \int_0^\infty \int_0^h f(z) e^{-2\pi i m \bar{z} / h} y^{k-2} dx dy \\
 &= \sum_{n=1}^\infty a_n \int_0^\infty e^{-2\pi(m+n)y/h} y^{k-2} dy \int_0^h e^{2\pi i(n-m)x/h} dx \\
 &= \begin{cases} 0 & (m=0), \\ a_m (4\pi m)^{1-k} h^k \Gamma(k-1) & (m \geq 1). \end{cases} \quad \square
 \end{aligned}$$

Corollary 2.6.11. *Assume $k \geq 3$. If there exists a cusp x of Γ satisfying (2.6.8), then $\{g_k^{(m)}(z) | m \geq 1\}$ generates $\mathcal{S}_k(\Gamma, \chi)$.*

Proof. We may assume $x = \infty$ and $\sigma = 1$ by the same reason as above. Let \mathcal{M} be the subspace of $\mathcal{S}_k(\Gamma, \chi)$ generated by $\{g_k^{(m)}(z) | m \geq 1\}$, and \mathcal{M}^\perp the orthocomplement of \mathcal{M} . Take an element $f(z) = \sum_{n=1}^\infty a_n e^{2\pi i n z / h}$ of \mathcal{M}^\perp , then by Theorem 2.6.10, we see $a_n = 0$ for all $n \geq 1$, so that $f(z) = 0$. Therefore we obtain $\mathcal{S}_k(\Gamma, \chi) = \mathcal{M}$. \square

Assume $k \geq 3$ and let $\{x_1, \dots, x_r\}$ be a set of complete representatives of cusps of Γ satisfying (2.6.8). For each x_i ($1 \leq i \leq r$), take $\sigma_i \in SL_2(\mathbb{R})$ so that $\sigma_i x_i = \infty$, and put

$$(2.6.14) \quad g_i(z) = F_k(z; \phi_0, \chi, \Gamma_{x_i}, \Gamma) \in \mathcal{G}_k(\Gamma, \chi).$$

Then we have

Corollary 2.6.12. *If $k \geq 3$, then $\mathcal{N}_k(\Gamma, \chi)$ is generated by the Eisenstein series $g_i(z)$ given by (2.6.14), or*

$$\mathcal{N}_k(\Gamma, \chi) = \langle g_i(z) \mid 1 \leq i \leq r \rangle.$$

Proof. Let us denote by $\mathcal{N}'_k(\Gamma, \chi)$ the right-hand side. By Theorem 2.6.10, we see $\mathcal{N}'_k(\Gamma, \chi) \subset \mathcal{N}_k(\Gamma, \chi)$. Now let $f(z)$ be an element of $\mathcal{G}_k(\Gamma, \chi)$, and x a cusp of Γ which does not satisfy (2.6.8). Then it is easy to see that $f(z)$ vanishes at x . For each i , let $a_0^{(i)}$ be the constant term of the Fourier expansion of $f|_k \sigma_i^{-1}$, or

$$(f|_k \sigma_i^{-1})(z) = a_0^{(i)} + \dots.$$

Then $f(z) - \sum_{i=1}^r a_0^{(i)} g_i(z)$ is a cusp form by Theorem 2.6.9(2). Therefore $\mathcal{G}_k(\Gamma, \chi)$ is generated by $\mathcal{N}'_k(\Gamma, \chi)$ and $\mathcal{S}_k(\Gamma, \chi)$. This combined with Theorem 2.1.7(1) implies the assertion. \square

We shall generalize Corollary 2.6.12 to $k \geq 1$ for modular groups in Chapter 7.

§2.7. Hecke Algebras

In this section, we explain the general theory of Hecke algebras. Though our purpose is the application to Fuchsian groups and modular forms, the groups considered in this section are abstract ones.

Let G be a group, and Γ, Γ' two subgroups of G . We say that Γ and Γ' are *commensurable* and write $\Gamma \approx \Gamma'$ if

$$[\Gamma : \Gamma \cap \Gamma'] < \infty \quad \text{and} \quad [\Gamma' : \Gamma \cap \Gamma'] < \infty.$$

For a subgroup Γ of G , we put

$$\tilde{\Gamma} = \{g \in G \mid g\Gamma g^{-1} \approx \Gamma\}.$$

Lemma 2.7.1. (1) *The relation \approx is an equivalent relation.*

(2) *$\tilde{\Gamma}$ is a subgroup of G .*

(3) *If $\Gamma \approx \Gamma'$, then $\tilde{\Gamma} = \tilde{\Gamma}'$.*

(4) *Suppose $\Gamma \approx \Gamma'$. Then for any element α of $\tilde{\Gamma}$, we have the following coset decompositions:*

$$\Gamma \alpha \Gamma' = \coprod_i \Gamma \alpha \gamma_i = \coprod_j \delta_j \alpha \Gamma',$$

where $\{\gamma_i\}$ (resp. $\{\delta_j\}$) is a finite set of the representatives of $(\Gamma' \cap \alpha^{-1} \Gamma \alpha) \backslash \Gamma'$ (resp. $\Gamma / (\Gamma \cap \alpha \Gamma' \alpha^{-1})$).

Proof. (1): We have only to show the transitive law. Let $\Gamma_1, \Gamma_2, \Gamma_3$ be subgroups of G such that $\Gamma_1 \approx \Gamma_2, \Gamma_2 \approx \Gamma_3$. Then

$$\begin{aligned} [\Gamma_1 : \Gamma_1 \cap \Gamma_2 \cap \Gamma_3] &= [\Gamma_1 : \Gamma_1 \cap \Gamma_2] [\Gamma_1 \cap \Gamma_2 : \Gamma_1 \cap \Gamma_2 \cap \Gamma_3] \\ &\leq [\Gamma_1 : \Gamma_1 \cap \Gamma_2] [\Gamma_2 : \Gamma_2 \cap \Gamma_3] < \infty. \end{aligned}$$

Similarly, we get $[\Gamma_3 : \Gamma_1 \cap \Gamma_2 \cap \Gamma_3] < \infty$. Since $\Gamma_1 \cap \Gamma_3 \supset \Gamma_1 \cap \Gamma_2 \cap \Gamma_3$, we obtain $[\Gamma_1 : \Gamma_1 \cap \Gamma_3] < \infty$ and $[\Gamma_3 : \Gamma_1 \cap \Gamma_3] < \infty$, so that $\Gamma_1 \approx \Gamma_3$. (2): Let g, h be two elements of $\tilde{\Gamma}$. Since

$$(h^{-1}g)\Gamma(h^{-1}g)^{-1} \approx h^{-1}\Gamma h \approx \Gamma,$$

$h^{-1}g$ also belongs to $\tilde{\Gamma}$ by (1). This shows that $\tilde{\Gamma}$ is a subgroup of G . (3): If g is an element of $\tilde{\Gamma}$, we see

$$g\Gamma'g^{-1} \approx g\Gamma g^{-1} \approx \Gamma \approx \Gamma'.$$

Thus g belongs to $\tilde{\Gamma}'$ by (1); namely $\tilde{\Gamma} \subset \tilde{\Gamma}'$. Exchanging Γ and Γ' , we get $\tilde{\Gamma}' \subset \tilde{\Gamma}$. Therefore $\tilde{\Gamma} = \tilde{\Gamma}'$. (4): We can express every left Γ -coset contained in $\Gamma\alpha\Gamma'$ as $\Gamma\alpha\gamma$ with some $\gamma \in \Gamma'$. For two left Γ -cosets $\Gamma\alpha\gamma$ and $\Gamma\alpha\gamma'$ contained in $\Gamma\alpha\Gamma'$,

$$(2.7.1) \quad \Gamma\alpha\gamma = \Gamma\alpha\gamma' \Leftrightarrow \gamma'\gamma^{-1} \in \Gamma' \cap \alpha^{-1}\Gamma\alpha.$$

Since $\alpha^{-1}\Gamma\alpha \approx \Gamma \approx \Gamma'$, we have $d = [\Gamma' : \Gamma' \cap \alpha^{-1}\Gamma\alpha] < \infty$. Therefore, taking a complete set of the representatives $\{\gamma_1, \dots, \gamma_d\}$ of $(\Gamma' \cap \alpha^{-1}\Gamma\alpha) \backslash \Gamma'$, we get the coset decomposition

$$\Gamma\alpha\Gamma' = \bigsqcup_{i=1}^d \Gamma\alpha\gamma_i$$

by (2.7.1). A similar argument is applicable to the second one. \square

Let Ξ be a set consisting of subgroups of G , and Δ a subsemigroup of G . We assume that Ξ and Δ satisfy the following conditions:

- (i) any two elements of Ξ are commensurable;
- (ii) $\tilde{\Gamma} \supset \Delta \supset \Gamma$ for all subgroups Γ in Ξ .

Hereafter $\Gamma, \Gamma', \Gamma_i$, etc., indicate subgroups of G belonging to Ξ .

Let K be a commutative ring with unity. For two elements Γ, Γ' of Ξ , we denote by $\mathcal{R}_K(\Gamma, \Gamma'; \Delta)$ the free K -module generated by double cosets $\Gamma\alpha\Gamma'$ with $\alpha \in \Delta$; namely

$$\mathcal{R}_K(\Gamma, \Gamma'; \Delta) = \left\{ \sum_{\alpha \in \Delta} a_\alpha \Gamma\alpha\Gamma' \mid a_\alpha \in K, \text{ and } a_\alpha = 0 \text{ except for finitely many } \alpha \right\}.$$

When $\Gamma = \Gamma'$, we write simply

$$\mathcal{R}_K(\Gamma, \Delta) = \mathcal{R}_K(\Gamma, \Gamma; \Delta).$$

When $K = \mathbb{Z}$, we also write

$$\mathcal{R}(\Gamma, \Gamma'; \Delta) = \mathcal{R}_{\mathbb{Z}}(\Gamma, \Gamma'; \Delta), \quad \mathcal{R}(\Gamma, \Delta) = \mathcal{R}_{\mathbb{Z}}(\Gamma, \Delta).$$

Assume that Δ acts on a K -module M and write the action as

$$M \times \Delta \ni (m, \delta) \mapsto m^\delta \in M;$$

namely, the following properties are satisfied:

- (i) " $m \mapsto m^\delta$ " is a K -endomorphism of M ;
- (ii) $m^{\delta\gamma} = (m^\delta)^\gamma$ for $\delta, \gamma \in \Delta$;
- (iii) $m^1 = m$ for the unity 1 of Δ .

We denote by M^Γ the submodule consisting of the Γ -invariant elements of M ; namely,

$$M^\Gamma = \{m \in M \mid m^\gamma = m \text{ for all } \gamma \in \Gamma\}.$$

Let $\Gamma\alpha\Gamma' = \coprod_i \Gamma\alpha_i$ be a coset decomposition. We define the action of $\Gamma\alpha\Gamma'$ on M^Γ by

$$m \mid \Gamma\alpha\Gamma' = \sum_i m^{\alpha_i}, \quad m \in M^\Gamma.$$

We also define the action of an element $\xi = \sum_\alpha a_\alpha \Gamma\alpha\Gamma'$ of $\mathcal{R}_K(\Gamma, \Gamma'; \Delta)$ on M^Γ by

$$m \mid \xi = \sum_\alpha a_\alpha (m \mid \Gamma\alpha\Gamma'), \quad m \in M^\Gamma.$$

Lemma 2.7.2. *Let the notation be the same as above.*

- (1) $m \mid \Gamma\alpha\Gamma'$ is independent of the choice of the representatives $\{\alpha_i\}$.
- (2) The mapping “ $m \mapsto m \mid \xi$ ” is a K -homomorphism of M^Γ into M^Γ .

Proof. For two elements α_i, α'_i of $\Gamma\alpha\Gamma'$ satisfying $\Gamma\alpha_i = \Gamma\alpha'_i$, there exists an element γ of Γ such that $\alpha'_i = \gamma\alpha_i$. Thus $m^{\alpha'_i} = m^{\gamma\alpha_i} = m^{\alpha_i}$. This proves (1). It is obvious that “ $m \mapsto m \mid \xi$ ” defines a K -homomorphism. Let us show $m \mid \xi \in M^\Gamma$. Since $\Gamma\alpha\Gamma' = \coprod_i \Gamma\alpha_i = \coprod_i \Gamma\alpha_i\gamma'$ for any element γ' of Γ' , we have

$$(m \mid \Gamma\alpha\Gamma')^{\gamma'} = \sum m^{\alpha_i\gamma'} = \sum m^{\alpha_i} = m \mid \Gamma\alpha\Gamma'$$

by (1). Hence $m \mid \Gamma\alpha\Gamma'$ belongs to M^Γ . □

Let $\Gamma_1\alpha\Gamma_2 = \coprod_i \Gamma_1\alpha_i$, and $\Gamma_2\beta\Gamma_3 = \coprod_j \Gamma_2\beta_j$ for two elements α, β of Δ . We define the multiplication of $\Gamma_1\alpha\Gamma_2$ and $\Gamma_2\beta\Gamma_3$ by

$$(2.7.2) \quad \Gamma_1\alpha\Gamma_2 \cdot \Gamma_2\beta\Gamma_3 = \sum_\gamma c_\gamma \Gamma_1\gamma\Gamma_3,$$

$$c_\gamma = \# \{(i, j) \mid \Gamma_1\alpha_i\beta_j = \Gamma_1\gamma\},$$

where the summation is taken over all double cosets $\Gamma_1\gamma\Gamma_3$ contained in Δ . The right-hand side is a finite sum, since $c_\gamma = 0$ except for finitely many $\Gamma_1\gamma\Gamma_3$'s. We extend this multiplication linearly, and define the multiplication of $\xi = \sum_\alpha a_\alpha \Gamma_1\alpha\Gamma_2 \in \mathcal{R}_K(\Gamma_1, \Gamma_2; \Delta)$ and $\eta = \sum_\beta b_\beta \Gamma_2\beta\Gamma_3 \in \mathcal{R}_K(\Gamma_2, \Gamma_3; \Delta)$ by

$$(2.7.3) \quad \xi\eta = \sum_{\alpha, \beta} a_\alpha b_\beta (\Gamma_1\alpha\Gamma_2 \cdot \Gamma_2\beta\Gamma_3).$$

Lemma 2.7.3. *The multiplication defined by (2.7.2) is independent of the choice of the representatives $\alpha_i, \beta_j, \gamma$.*

Proof. Let $K[\Gamma_1 \setminus \Delta]$ be the free K -module generated by left Γ_1 -cosets $\Gamma_1\alpha$ ($\alpha \in \Delta$) contained in Δ , then $K[\Gamma_1 \setminus \Delta]$ is a right Δ -module by the right multiplication. The correspondence of $\Gamma_1\alpha\Gamma_2 = \coprod_i \Gamma_1\alpha_i$ to $\sum_i \Gamma_1\alpha_i$ induces an injective K -homomorphism of $\mathcal{R}_K(\Gamma_1, \Gamma_2; \Delta)$ into $K[\Gamma_1 \setminus \Delta]$. Considering $\mathcal{R}_K(\Gamma_1, \Gamma_2; \Delta)$ as a K -submodule of $K[\Gamma_1 \setminus \Delta]$ by this mapping, we obtain

$$(2.7.4) \quad \mathcal{R}_K(\Gamma_1, \Gamma_2; \Delta) = K[\Gamma_1 \setminus \Delta]^{\Gamma_2}.$$

Let $\Gamma_1 \alpha \Gamma_2 = \coprod_i \Gamma_1 \alpha_i$, and $\Gamma_2 \beta \Gamma_3 = \coprod_j \Gamma_2 \beta_j$ be cosets decompositions, then by the definition of the action of $\mathcal{R}_K(\Gamma_2, \Gamma_3; \Delta)$ on $K[\Gamma_1 \backslash \Delta]^{\Gamma_2}$, we see

$$(2.7.5) \quad \sum_i \Gamma_1 \alpha_i | \Gamma_2 \beta \Gamma_3 = \sum_i \sum_j \Gamma_1 \alpha_i \beta_j.$$

Since the right-hand side coincides with the right-hand side of (2.7.2) under our identification, we see that

(2.7.6) *the action of $\mathcal{R}_K(\Gamma_2, \Gamma_3; \Delta)$ on $\mathcal{R}_K(\Gamma_1, \Gamma_2; \Delta) = K[\Gamma_1 \backslash \Delta]^{\Gamma_2}$ is no other than the multiplication defined by (2.7.3).*

Hence Lemma 2.7.2(1) implies the assertion. \square

The argument in the proof of Lemma 2.7.3 implies also the following

Lemma 2.7.4. *Under the notation and assumptions as above, we have:*

- (1) $(m | \xi_1) | \xi_2 = m | (\xi_1 \xi_2)$ for $m \in M^{\Gamma_1}$, $\xi_1 \in \mathcal{R}_K(\Gamma_1, \Gamma_2; \Delta)$, and $\xi_2 \in \mathcal{R}_K(\Gamma_2, \Gamma_3; \Delta)$;
- (2) $(\xi_1 \xi_2) \xi_3 = \xi_1 (\xi_2 \xi_3)$ for $\xi_1 \in \mathcal{R}_K(\Gamma_1, \Gamma_2; \Delta)$, $\xi_2 \in \mathcal{R}_K(\Gamma_2, \Gamma_3; \Delta)$, and $\xi_3 \in \mathcal{R}_K(\Gamma_3, \Gamma_4; \Delta)$;
- (3) $\mathcal{R}_K(\Gamma, \Delta)$ is an algebra over K with unity Γ ;
- (4) If M is a right Δ -module, then M^Γ is a right $\mathcal{R}_K(\Gamma, \Delta)$ -module.

Proof. The first assertion is obvious by definition. The second assertion is obtained by (1) and (2.7.6). The third and the fourth are easily verified from (2) and (1), respectively. \square

We call $\mathcal{R}(\Gamma, \Delta)$ (resp. $\mathcal{R}_K(\Gamma, \Delta)$) the *Hecke algebra* (resp. the *Hecke algebra over K*) of Γ with respect to Δ .

Lemma 2.7.5. *If $\Delta \subset \Delta'$, then $\mathcal{R}_K(\Gamma, \Delta)$ is a subalgebra of $\mathcal{R}_K(\Gamma, \Delta')$ under the natural correspondence. In particular, $\mathcal{R}_K(\Gamma, \Delta)$ is a subalgebra of $\mathcal{R}_K(\Gamma, \tilde{\Gamma})$.*

Proof. We have only to show that the multiplication of $\mathcal{R}_K(\Gamma, \Delta)$ coincides with that of $\mathcal{R}_K(\Gamma, \Delta')$. For two elements $\Gamma \alpha \Gamma, \Gamma \beta \Gamma$ of $\mathcal{R}_K(\Gamma, \Delta)$, denote the multiplication of them as elements of $\mathcal{R}_K(\Gamma, \Delta')$ by

$$\Gamma \alpha \Gamma \cdot \Gamma \beta \Gamma = \sum_{\gamma} c_{\gamma} \Gamma \gamma \Gamma.$$

Since $\Gamma \gamma \Gamma \subset \Gamma \alpha \Gamma \beta \Gamma \subset \Delta$ if $c_{\gamma} \neq 0$, this coincides with the multiplication as elements of $\mathcal{R}_K(\Gamma, \Delta)$. \square

Theorem 2.7.6. (1) *For two subgroups Γ and U of a group G , let Δ, D be semigroups of G such that $\tilde{\Gamma} \supset \Delta \supset \Gamma$ and $\tilde{U} \supset D \supset U$. Further we assume*

- (i) $D = U\Delta$,
- (ii) $U\alpha U = U\alpha\Gamma$ for any $\alpha \in \Delta$,
- (iii) $U\alpha \cap \Delta = \Gamma\alpha$ for any $\alpha \in \Delta$.

Then the correspondence “ $\Gamma\alpha\Gamma \mapsto U\alpha U$ ” induces an isomorphism of $\mathcal{R}_K(\Gamma, \Delta)$ onto $\mathcal{R}_K(U, D)$.

(2) When a K -module M is also a right D -module, the action of $\mathcal{R}_K(\Gamma, \Delta)$ on M^Γ corresponds to that of $\mathcal{R}_K(U, D)$ on M^U under the above isomorphism; namely,

$$m|U\alpha U = m|\Gamma\alpha\Gamma$$

for $m \in M^U$, $\alpha \in \Delta$.

Proof. We note that $\Gamma \subset U$ by (ii). Let Φ be the mapping of $\mathcal{R}_K(\Gamma, \Delta)$ into $\mathcal{R}_K(U, D)$ induced by the correspondence “ $\Gamma\alpha\Gamma \mapsto U\alpha U$ ”. By (i), Φ is surjective. Suppose $U\alpha U = U\beta U$ for two elements α, β of Δ . By (ii), there exist elements $u \in U$, $\gamma \in \Gamma$ such that $\beta\gamma = u\alpha$. Since $\beta\gamma = u\alpha$ belongs to $U\alpha \cap \Delta = \Gamma\alpha$ by (iii), we get $\Gamma\alpha\Gamma = \Gamma\beta\Gamma$. Therefore Φ is also injective, since $\mathcal{R}_K(U, D)$ is a free K -module with a basis $\{U\alpha U\}$. To see that Φ is a ring-homomorphism, we have only to prove that if $\Gamma\alpha\Gamma = \coprod_i \Gamma\alpha_i$ ($\alpha_i \in \Delta$), then $U\alpha U = \coprod_i U\alpha_i$. Let $\Gamma\alpha\Gamma = \coprod_i \Gamma\alpha_i$. Condition (ii) implies $U\alpha U = \bigcup_i U\alpha_i$. If $U\alpha_i = U\alpha_j$, then $\alpha_j \in U\alpha_i \cap \Delta = \Gamma\alpha_i$, so that $\Gamma\alpha_i = \Gamma\alpha_j$. Thus $U\alpha U = \coprod_i U\alpha_i$. This proves (2). \square

For an element $\xi = \sum_\alpha a_\alpha(\Gamma\alpha\Gamma)$ of $\mathcal{R}(\Gamma, \Delta)$, we put

$$\deg(\xi) = \sum_\alpha a_\alpha |\Gamma \backslash \Gamma\alpha\Gamma|$$

and call it the *degree* of ξ . Here $|\Gamma \backslash \Gamma\alpha\Gamma|$ indicates the number of left Γ -cosets contained in $\Gamma\alpha\Gamma$. In view of (2.7.5) and (2.7.6), we see easily

$$(2.7.7) \quad \deg(\xi\eta) = \deg(\xi)\deg(\eta) \quad \text{for } \xi, \eta \in \mathcal{R}(\Gamma, \Delta).$$

Lemma 2.7.7. *Let $\alpha \in \tilde{\Gamma}$. If $|\Gamma \backslash \Gamma\alpha\Gamma| = |\Gamma\alpha\Gamma/\Gamma|$, then $\Gamma \backslash \Gamma\alpha\Gamma$ and $\Gamma\alpha\Gamma/\Gamma$ have a common set of representatives.*

Proof. Let $\Gamma\alpha\Gamma = \coprod_{i=1}^d \Gamma\alpha_i = \coprod_{i=1}^d \beta_i\Gamma$. Then $\Gamma\alpha_i \cap \beta_j\Gamma \neq \emptyset$ for any i, j . In fact, suppose $\Gamma\alpha_i \cap \beta_j\Gamma = \emptyset$ for some i, j . Since $\Gamma\alpha_i \subset \bigcup_{k \neq j} \beta_k\Gamma$, we have $\Gamma\alpha\Gamma = \Gamma\alpha_i\Gamma = \bigcup_{k \neq j} \beta_k\Gamma$; this is a contradiction. In particular, $\Gamma\alpha_i \cap \beta_i\Gamma \neq \emptyset$, so that taking an element $\delta_i \in \Gamma\alpha_i \cap \beta_i\Gamma$, we get $\Gamma\alpha_i = \Gamma\delta_i$ and $\beta_i\Gamma = \delta_i\Gamma$. Therefore we obtain

$$\Gamma\alpha\Gamma = \coprod_{i=1}^d \Gamma\delta_i = \coprod_{i=1}^d \delta_i\Gamma. \quad \square$$

Theorem 2.7.8. *Assume that there exists a mapping ι of Δ into itself satisfying*

- (i) $(\alpha\beta)^\iota = \beta^\iota\alpha^\iota$ and $(\alpha^\iota)^\iota = \alpha$ for $\alpha, \beta \in \Delta$,
- (ii) $\Gamma^\iota = \Gamma$,
- (iii) $\Gamma\alpha^\iota\Gamma = \Gamma\alpha\Gamma$.

Then the following assertions hold.

- (1) For any $\alpha \in \Delta$, $\Gamma \backslash \Gamma\alpha\Gamma$ and $\Gamma\alpha\Gamma/\Gamma$ has a common set of representatives.
- (2) The Hecke algebra $\mathcal{R}_K(\Gamma, \Delta)$ is commutative.

Proof. Let $\Gamma\alpha\Gamma = \coprod_i \Gamma\alpha_i$ for $\alpha \in \Delta$. Then $\Gamma\alpha\Gamma = \Gamma\alpha'\Gamma = (\Gamma\alpha\Gamma)' = \coprod_i \alpha'_i\Gamma$. Thus (1) follows from Lemma 2.7.7. Hence we may put $\Gamma\alpha\Gamma = \coprod_i \Gamma\alpha_i = \coprod_i \alpha'_i\Gamma$, and $\Gamma\beta\Gamma = \coprod_j \Gamma\beta_j = \coprod_j \beta'_j\Gamma$. Let

$$\Gamma\alpha\Gamma \cdot \Gamma\beta\Gamma = \sum_{\gamma} c_{\gamma} \Gamma\gamma\Gamma, \quad \Gamma\beta\Gamma \cdot \Gamma\alpha\Gamma = \sum_{\gamma'} c'_{\gamma'} \Gamma\gamma'\Gamma,$$

then

$$\begin{aligned} c_{\gamma} &= \# \{(i, j) | \Gamma\alpha_i\beta_j = \Gamma\gamma\} \\ &= \# \{(i, j) | \Gamma\alpha_i\beta_j\Gamma = \Gamma\gamma\Gamma\} / |\Gamma \backslash \Gamma\gamma\Gamma| \\ &= \# \{(i, j) | \Gamma\beta'_j\alpha'_i\Gamma = \Gamma\gamma'\Gamma\} / |\Gamma \backslash \Gamma\gamma'\Gamma| \\ &= \# \{(i, j) | \Gamma\beta'_j\alpha'_i = \Gamma\gamma'\} \\ &= c'_{\gamma'}. \end{aligned}$$

Therefore we obtain $\Gamma\alpha\Gamma \cdot \Gamma\beta\Gamma = \Gamma\beta\Gamma \cdot \Gamma\alpha\Gamma$. □

§2.8. Hecke Operators on the Space of Automorphic Forms

In the previous section, we defined the Hecke algebra in the general framework. Now we are going to let Hecke algebras act on the spaces of automorphic forms.

Let Γ be a Fuchsian group, and χ a character of Γ of finite order. Considering Γ as a subgroup of $GL_2^+(\mathbb{R})$, we put

$$\tilde{\Gamma} = \{g \in GL_2^+(\mathbb{R}) | g\Gamma g^{-1} \approx \Gamma\}.$$

Let Δ be a subsemigroup of $\tilde{\Gamma}$ such that $\tilde{\Gamma} \supset \Delta \supset \Gamma$. Assume that χ can be extended to a character of Δ , which we denote by the same symbol χ , and that the following condition is satisfied:

$$(2.8.1) \quad \text{if } \alpha\gamma\alpha^{-1} \in \Gamma (\gamma \in \Gamma, \alpha \in \Delta), \text{ then } \chi(\alpha\gamma\alpha^{-1}) = \chi(\gamma).$$

Now let \mathcal{E} be a set of all subgroups of Γ of finite index. For $\Gamma_1, \Gamma_2 \in \mathcal{E}$ and $\alpha \in \Delta$, put $\Gamma_1\alpha\Gamma_2 = \coprod_{v=1}^d \Gamma_1\alpha_v$. Then for any element $f(z)$ of $\mathcal{A}_k(\Gamma_1, \chi)$, we put

$$\begin{aligned} (2.8.2) \quad (f|_{\Gamma_1\alpha\Gamma_2})(z) &= \det(\alpha)^{k/2-1} \sum_{v=1}^d \overline{\chi(\alpha_v)} (f|_{\alpha_v})(z) \\ &= \det(\alpha)^{k-1} \sum_{v=1}^d \overline{\chi(\alpha_v)} j(\alpha_v, z)^{-k} f(\alpha_v z). \end{aligned}$$

Theorem 2.8.1. (1) *The above definition is independent of the choice of the representatives α_v , and*

$$f|_{\Gamma_1\alpha\Gamma_2} \in \mathcal{A}_k(\Gamma_2, \chi).$$

Moreover if $f \in \mathcal{G}_k(\Gamma_1, \chi)$ (resp. $\in \mathcal{S}_k(\Gamma_1, \chi)$), then $f|_{\Gamma_1 \alpha \Gamma_2} \in \mathcal{G}_k(\Gamma_2, \chi)$ (resp. $\in \mathcal{S}_k(\Gamma_2, \chi)$).

(2) If $\Gamma_1, \Gamma_2, \Gamma_3 \in \Xi$ and $\alpha, \beta \in \Delta$, then

$$(f|_{\Gamma_1 \alpha \Gamma_2})|_{\Gamma_2 \beta \Gamma_3} = f|_{(\Gamma_1 \alpha \Gamma_2 \cdot \Gamma_2 \beta \Gamma_3)}.$$

(3) Under the above action, $\mathcal{A}_k(\Gamma, \chi)$ is a right $\mathcal{R}(\Gamma, \Delta)$ -module, and both $\mathcal{G}_k(\Gamma, \chi)$ and $\mathcal{S}_k(\Gamma, \chi)$ are its $\mathcal{R}(\Gamma, \Delta)$ -submodules.

Proof. Put

$$\mathcal{A}_k = \bigcup_{\Gamma' \in \Xi} \mathcal{A}_k(\Gamma', \chi), \quad \mathcal{G}_k = \bigcup_{\Gamma' \in \Xi} \mathcal{G}_k(\Gamma', \chi), \quad \mathcal{S}_k = \bigcup_{\Gamma' \in \Xi} \mathcal{S}_k(\Gamma', \chi).$$

Since

$$\mathcal{A}_k(\Gamma_1, \chi) \cup \mathcal{A}_k(\Gamma_2, \chi) \subset \mathcal{A}_k(\Gamma_1 \cap \Gamma_2, \chi),$$

for $\Gamma_1, \Gamma_2 \in \Xi$, \mathcal{A}_k is a vector space over \mathbb{C} . Similarly, both \mathcal{G}_k and \mathcal{S}_k are subspaces of \mathcal{A}_k . We define the action of an element α of Δ on \mathcal{A}_k by

$$f^\alpha = \det(\alpha)^{k/2-1} \overline{\chi(\alpha)} (f|_k \alpha), \quad f \in \mathcal{A}_k.$$

Since by (2.8.1) f^α belongs to $\mathcal{A}_k(\Gamma_1 \cap \alpha^{-1} \Gamma_1 \alpha, \chi)$ provided f does to $\mathcal{A}_k(\Gamma_1, \chi)$ ($\Gamma_1 \in \Xi$), “ $f \mapsto f^\alpha$ ” is a linear mapping of \mathcal{A}_k into itself. It is obvious that $(f^\alpha)^\beta = f^{\alpha\beta}$ for any $\alpha, \beta \in \Delta$. Thus Δ acts on \mathcal{A}_k and $\mathcal{A}_k^{\Gamma_1} = \mathcal{A}_k(\Gamma_1, \chi)$ for any $\Gamma_1 \in \Xi$. Furthermore if $f \in \mathcal{A}_k(\Gamma_1, \chi)$ and $\Gamma_1 \alpha \Gamma_2 = \coprod_v \Gamma_1 \alpha_v$ ($\alpha \in \Delta$), then we have

$$f|_{\Gamma_1 \alpha \Gamma_2} = \sum_v f^{\alpha_v}.$$

Hence by Lemma 2.7.2, the above definition is independent of the choice of the representatives α_v , and $f|_{\Gamma_1 \alpha \Gamma_2}$ belongs $\mathcal{A}_k(\Gamma_2, \chi)$. A similar argument is also applicable to the latter half of the first assertion. Assertions (2) and (3) are special cases of Lemma 2.7.4(1) and (4), respectively. \square

A linear mapping of $\mathcal{A}_k(\Gamma_1, \chi)$ into $\mathcal{A}_k(\Gamma_2, \chi)$ induced by $\Gamma_1 \alpha \Gamma_2$ ($\alpha \in \Delta$) is called a *Hecke operator*.

Remark 2.8.1. Since the action of $\Gamma_1 \alpha \Gamma_2$ on $\mathcal{A}_k(\Gamma_1, \chi)$ depends on k and χ , we should distinguish an element of $\mathcal{R}(\Gamma_1, \Gamma_2; \Delta)$ from the Hecke operator. We use, however, the same symbol for simplicity, since the action of $\Gamma_1 \alpha \Gamma_2$ is determined uniquely.

Remark 2.8.2. When χ is the identity character, we can take as Δ any semigroup satisfying $\tilde{\Gamma} \supset \Delta \supset \Gamma$. In particular, $\mathcal{R}(\Gamma, \tilde{\Gamma})$ acts on $\mathcal{A}_k(\Gamma)$, $\mathcal{G}_k(\Gamma)$, and $\mathcal{S}_k(\Gamma)$.

Let $(\ , \)$ be the Petersson inner product. Then we have

Theorem 2.8.2. For $\alpha \in GL_2^+(\mathbb{R})$, we put $\alpha' = \det(\alpha)\alpha^{-1}$.

(1) Assume $\Gamma_1 \approx \Gamma_2$. Then for $\alpha \in \tilde{\Gamma}_1 (= \tilde{\Gamma}_2)$,

$$(f|_k \alpha, g) = (f, g|_k \alpha'), \quad f(z) \in \mathcal{S}_k(\Gamma_1), \quad g(z) \in \mathcal{G}_k(\Gamma_2).$$

(2) For $\alpha \in \tilde{\Gamma}$,

$$(f|_{\Gamma\alpha}\Gamma, g) = (f, g|_{\Gamma\alpha'}\Gamma), \quad f(z) \in \mathcal{S}_k(\Gamma), \quad g(z) \in \mathcal{G}_k(\Gamma).$$

Proof. (1): Put $\Gamma = \alpha^{-1}\Gamma_1\alpha \cap \Gamma_2$. Since $f|_k \alpha \in \mathcal{S}_k(\alpha^{-1}\Gamma_1\alpha)$, we see

$$\begin{aligned} (f|_k \alpha, g) &= v(\Gamma \backslash \mathbf{H})^{-1} \int_{\Gamma \backslash \mathbf{H}} \det(\alpha)^{k/2} j(\alpha, z)^{-k} f(\alpha z) \overline{g(z)} \operatorname{Im}(z)^k dv(z) \\ &= v(\Gamma \backslash \mathbf{H})^{-1} \int_{\alpha\Gamma\alpha^{-1} \backslash \mathbf{H}} \det(\alpha)^{k/2} f(z) \overline{g(\alpha^{-1}z)} j(\alpha, \alpha^{-1}z)^{-k} \operatorname{Im}(\alpha^{-1}z)^k dv(z). \end{aligned}$$

Since $\alpha^{-1}z = \alpha'z$, $j(\alpha, \alpha^{-1}z) = j(\alpha, \alpha'z) = \det(\alpha)j(\alpha', z)^{-1}$, $\operatorname{Im}(\alpha^{-1}z) = \operatorname{Im}(\alpha'z)$
 $= \det(\alpha')|j(\alpha', z)|^{-2} \operatorname{Im}(z)$, $\det(\alpha) = \det(\alpha')$, and $v(\Gamma \backslash \mathbf{H}) = v(\alpha\Gamma\alpha^{-1} \backslash \mathbf{H})$, we get

$$\begin{aligned} (f|_k \alpha, g) &= v(\alpha\Gamma\alpha^{-1} \backslash \mathbf{H})^{-1} \int_{\alpha\Gamma\alpha^{-1} \backslash \mathbf{H}} f(z) \det(\alpha')^{k/2} \overline{g(\alpha'z)}^{-k} g(\alpha'z) \operatorname{Im}(z)^k dv(z) \\ &= (f, g|_k \alpha'). \end{aligned}$$

(2): Noting that $-1 \in \Gamma$ if and only if $-1 \in \alpha^{-1}\Gamma\alpha$, we see

$$\begin{aligned} [\Gamma : \Gamma \cap \alpha^{-1}\Gamma\alpha] &= v((\Gamma \cap \alpha^{-1}\Gamma\alpha) \backslash \mathbf{H}) / v(\Gamma \backslash \mathbf{H}) \\ &= v((\alpha\Gamma\alpha^{-1} \cap \Gamma) \backslash \mathbf{H}) / v(\Gamma \backslash \mathbf{H}) \\ &= [\Gamma : \Gamma \cap \alpha\Gamma\alpha^{-1}]. \end{aligned}$$

Thus Lemma 2.7.1(4) implies $|\Gamma \backslash \Gamma\alpha\Gamma| = |\Gamma\alpha\Gamma/\Gamma|$, so that both $\Gamma \backslash \Gamma\alpha\Gamma$ and $\Gamma\alpha\Gamma/\Gamma$ has a common set of representatives by Lemma 2.7.7. We may put $\Gamma\alpha\Gamma = \coprod_v \Gamma\alpha_v = \coprod_v \alpha_v\Gamma$ for some $\{\alpha_v\}$, then we have $\Gamma\alpha^{-1}\Gamma = \coprod_v \Gamma\alpha_v^{-1}$ and $\Gamma\alpha'\Gamma = \coprod_v \Gamma\alpha'_v$. Therefore we obtain

$$\begin{aligned} (f|_{\Gamma\alpha}\Gamma, g) &= \det(\alpha)^{k/2-1} \sum_v (f|_k \alpha_v, g) \\ &= \det(\alpha)^{k/2-1} \sum_v (f, g|_k \alpha'_v) \\ &= (f, g|_{\Gamma\alpha'}\Gamma). \end{aligned} \quad \square$$

Corollary 2.8.3. Let χ and ψ be two characters of Γ of finite order. If $\chi \neq \psi$, then $(f, g) = 0$ for $f \in \mathcal{S}_k(\Gamma, \chi)$ and $g \in \mathcal{G}_k(\Gamma, \psi)$.

Proof. Let γ be an element of Γ such that $\chi(\gamma) \neq \psi(\gamma)$. Then

$$\chi(\gamma)(f, g) = (f|_k \gamma, g) = (f, g|_k \gamma^{-1}) = \psi(\gamma)(f, g).$$

This implies $(f, g) = 0$. □

Corollary 2.8.4. *If $f \in \mathcal{N}_k(\Gamma)$, then $f|_{\Gamma\alpha\Gamma} \in \mathcal{N}_k(\Gamma)$ for any $\alpha \in \tilde{\Gamma}$.*

Proof. This is obvious from Theorem 2.8.2(2). □

We now explain the geometrical meaning of Hecke operators. We assume elementary knowledge of algebraic geometry. Let \mathfrak{R} be a compact Riemann surface. Then \mathfrak{R} is isomorphic to a nonsingular algebraic curve as complex manifolds. We define a subgroup of the divisor group of \mathfrak{R} by

$$\text{Div}_0(\mathfrak{R}) = \{\mathbf{a} \in \text{Div}(\mathfrak{R}) \mid \deg(\mathbf{a}) = 0\},$$

then from (2.2.8), we have $\text{Div}_1(\mathfrak{R}) \subset \text{Div}_0(\mathfrak{R})$. The quotient group

$$J = \text{Div}_0(\mathfrak{R})/\text{Div}_1(\mathfrak{R})$$

has a natural structure of a complex manifold which is an abelian variety. We call the abelian variety J the *jacobian variety of \mathfrak{R}* . We denote by $D_0^1(J)$ the space of holomorphic differentials on J , then

$$D_0^1(\mathfrak{R}) \simeq D_0^1(J).$$

Let now Γ be a Fuchsian group of the first kind. For $\alpha \in \tilde{\Gamma}$, the mapping

$$\mathbf{H}^* \ni z \mapsto (z, \alpha z) \in \mathbf{H}^* \times \mathbf{H}^*$$

induces an imbedding of $\mathfrak{R}_{\Gamma \cap \alpha \Gamma \alpha^{-1}}$ into $\mathfrak{R}_\Gamma \times \mathfrak{R}_\Gamma$. We denote by $T(\Gamma\alpha\Gamma)$ the image of $R_{\Gamma \cap \alpha \Gamma \alpha^{-1}}$ in $\mathfrak{R}_\Gamma \times \mathfrak{R}_\Gamma$. Then $T(\Gamma\alpha\Gamma)$ is an algebraic correspondence of \mathfrak{R}_Γ into itself. Put $\Gamma\alpha\Gamma \cdot \Gamma\beta\Gamma = \sum_\delta c_\delta \Gamma\delta\Gamma$ for $\alpha, \beta \in \tilde{\Gamma}$, then

$$T(\Gamma\alpha\Gamma)T(\Gamma\beta\Gamma) = \sum_\delta c_\delta T(\Gamma\delta\Gamma)$$

as algebraic correspondences. Moreover let $\pi: \mathbf{H}^* \rightarrow \mathfrak{R}_\Gamma$ be the canonical mapping, and $\Gamma\alpha\Gamma = \coprod_v \Gamma\alpha_v$. Then

$$(2.8.3) \quad T(\Gamma\alpha\Gamma)(\pi(z)) = \sum_v \pi(\alpha_v z).$$

We call $T(\Gamma\alpha\Gamma)$ a *modular correspondence*. By (2.8.3), $T(\Gamma\alpha\Gamma)$ induces an endomorphism $\tau(\Gamma\alpha\Gamma)$ of the jacobian variety J_Γ of \mathfrak{R}_Γ . The following diagram is commutative:

$$\begin{array}{ccc} \mathcal{S}_2(\Gamma) & \xrightarrow{\Gamma\alpha\Gamma} & \mathcal{S}_2(\Gamma) \\ \parallel & & \parallel \\ D_0^1(\mathfrak{R}_\Gamma) & & D_0^1(\mathfrak{R}_\Gamma) \\ \parallel & & \parallel \\ D_0^1(J_\Gamma) & \xrightarrow{\tau(\Gamma\alpha\Gamma)} & D_0^1(J_\Gamma) \end{array}$$

In particular, take a congruence modular group for Γ . Then both \mathfrak{R}_Γ and J_Γ are defined over \mathbb{Q} or over a cyclotomic field. In the investigation of \mathfrak{R}_Γ and J_Γ , in

particular in the arithmetical investigation, for example, of Hasse zeta functions or field extensions generated by section points of J_Γ , etc., the modular correspondences $T(\Gamma\alpha\Gamma)$ and the Hecke operators $\Gamma\alpha\Gamma$ play important roles. See [Shimura 2, 3, 4, 6], etc., for these theories. We shall study the Hecke algebra of modular groups in Chapter 4 and calculate the traces of Hecke operators on the spaces of cusp forms in Chapter 6. They are of course important in themselves. However, applications of them to number theory are always in our mind.

Chapter 3. L -Functions

In this chapter, we summarize basic facts of number theory and Dirichlet series for the succeeding chapters. Most of the important theorems are stated without proof. Readers who have number theoretical backgrounds can skip this chapter.

§ 3.1. Dirichlet Characters

Let N be a positive integer, and $\tilde{\chi}$ a character of $(\mathbb{Z}/N\mathbb{Z})^\times$. For any integer n , we put

$$(3.1.1) \quad \chi(n) = \begin{cases} \tilde{\chi}(n \bmod N) & \text{if } (n, N) = 1, \\ 0 & \text{if } (n, N) \neq 1, \end{cases}$$

then χ is a mapping of \mathbb{Z} into \mathbb{C} satisfying

- (i) $\chi(mn) = \chi(m)\chi(n)$;
- (ii) $\chi(m) = \chi(n)$ if $m \equiv n \pmod{N}$;
- (iii) $\chi(n) \neq 0$ if and only if $(n, N) = 1$.

The characters $\tilde{\chi}$ of $(\mathbb{Z}/N\mathbb{Z})^\times$ and the mappings χ of \mathbb{Z} into \mathbb{C} satisfying conditions (i) through (iii) correspond bijectively through (3.1.1). We call such a mapping χ of \mathbb{Z} into \mathbb{C} a *Dirichlet character mod N* , or simply a *character mod N* . We call N the *modulus* of χ . We call the Dirichlet character corresponding to the trivial character of $(\mathbb{Z}/N\mathbb{Z})^\times$ the *trivial character mod N* . Further we denote by χ_0 the trivial character mod 1 and call it the *principal character*.

For a Dirichlet character χ mod N , we define the *complex conjugate* $\bar{\chi}$ by

$$(3.1.2) \quad \bar{\chi}(n) = \overline{\chi(n)} \quad (n \in \mathbb{Z}),$$

which is also a character mod N . For a multiple M of N , we put

$$\chi'(n) = \begin{cases} \chi(n) & \text{if } (n, M) = 1, \\ 0 & \text{if } (n, M) \neq 1. \end{cases}$$

Then χ' is a character mod M . We call it the *character mod M induced from χ* .

For a character χ mod N , let M_χ be the set of positive integers m satisfying the following condition:

$$(3.1.3) \quad \text{if } (n, N) = 1 \quad \text{and} \quad n \equiv 1 \pmod{m}, \quad \text{then} \quad \chi(n) = 1.$$

Since N belongs to M_χ , M_χ is not empty. For any two elements m_1, m_2 of M_χ , the greatest common divisor of m_1 and m_2 also belongs to M_χ . Therefore the smallest integer m_χ contained in M_χ is a divisor of all elements of M_χ . We call m_χ the *conductor of χ* . When $N = m_\chi$, χ is called a *primitive character mod N* . If an integer n is prime to m_χ , then we can take an integer n' so that $(n', N) = 1$ and $n' \equiv n \pmod{m_\chi}$. We put

$$\chi^0(n) = \begin{cases} \chi(n') & \text{if } (n, m_\chi) = 1, \\ 0 & \text{if } (n, m_\chi) \neq 1, \end{cases}$$

then χ^0 is a primitive character mod m_χ . We call χ^0 the *primitive character associated with χ* and χ is induced from χ^0 .

For two Dirichlet characters $\chi \pmod{N}$ and $\psi \pmod{M}$, we put

$$(\chi\psi)(n) = \chi(n)\psi(n) \quad (n \in \mathbb{Z}),$$

then $\chi\psi$ is a character mod L for the least common multiple L of N and M . Let now χ be a character mod N , and $N = \prod_p p^e$ the decomposition as the product of primes. Fix a prime factor p . For an integer n prime to p , take a positive integer m so that

$$m \equiv \begin{cases} n \pmod{p^e}, \\ 1 \pmod{N/p^e}. \end{cases}$$

We put

$$\chi_p(n) = \begin{cases} \chi(m), & \text{if } (n, p) = 1, \\ 0, & \text{if } (n, p) \neq 1. \end{cases}$$

Then it is independent of the choice of m , and χ_p is a character mod p^e . Furthermore we have

$$(3.1.4) \quad \chi(n) = \prod_{p|N} \chi_p(n) \quad (n \in \mathbb{Z}).$$

For a primitive Dirichlet character χ with conductor m , we define the *Gauss sum* of χ by

$$(3.1.5) \quad W(\chi) = \sum_{a=0}^{m-1} \chi(a)e^{2\pi ia/m}.$$

The following lemma is fundamental.

Lemma 3.1.1. *Let χ be a primitive Dirichlet character mod m .*

- (1) $\sum_{a=0}^{m-1} \chi(a)e^{2\pi iab/m} = \bar{\chi}(b)W(\chi)$ for any integer b .
- (2) $W(\chi)W(\bar{\chi}) = \chi(-1)m$.
- (3) $\overline{W(\chi)} = \chi(-1)W(\bar{\chi})$.
- (4) $|W(\chi)|^2 = m$.

Proof. (1): First assume that b is prime to m . Since $\chi(a) = \chi(ab)\bar{\chi}(b)$, we see

$$\sum_{a=0}^{m-1} \chi(a)e^{2\pi iab/m} = \bar{\chi}(b) \sum_{a=0}^{m-1} \chi(ab)e^{2\pi iab/m} = \bar{\chi}(b)W(\chi).$$

Next suppose $(b, m) \neq 1$, and put $n = m/(b, m)$. Define a subgroup H of $(\mathbb{Z}/m\mathbb{Z})^\times$ by

$$H = \{d \in (\mathbb{Z}/m\mathbb{Z})^\times \mid d \equiv 1 \pmod{n}\},$$

and let $(\mathbb{Z}/m\mathbb{Z})^\times = \coprod_c Hc$ be a coset decomposition. Since χ is primitive, the restriction of χ on H is not trivial. In addition, $bd \equiv b \pmod{m}$ for any $d \in H$. Thus we see

$$\begin{aligned} \sum_a \chi(a) e^{2\pi i ab/m} &= \sum_c \sum_{d \in H} \chi(dc) e^{2\pi i bcd/m} \\ &= \sum_c \chi(c) e^{2\pi i bc/m} \sum_{d \in H} \chi(d) = 0. \end{aligned}$$

(2): By (1), we see

$$\begin{aligned} W(\chi) W(\bar{\chi}) &= \sum_{b=0}^{m-1} W(\chi) \bar{\chi}(b) e^{2\pi i b/m} \\ &= \sum_{b=0}^{m-1} \sum_{a=0}^{m-1} \chi(a) e^{2\pi i ab/m} e^{2\pi i b/m} \\ &= \sum_{a=0}^{m-1} \chi(a) \sum_{b=0}^{m-1} e^{2\pi i b(a+1)/m}. \end{aligned}$$

Since $\sum_{b=0}^{m-1} e^{2\pi i b(a+1)/m}$ is equal to m if $a+1 \equiv 0 \pmod{m}$, and to 0 otherwise, we get $W(\chi) W(\bar{\chi}) = \chi(-1)m$. Since $\chi(-1) = \pm 1$, we see

$$\overline{W(\chi)} = \sum_{a=0}^{m-1} \bar{\chi}(a) e^{-2\pi i a/m} = \bar{\chi}(-1) W(\bar{\chi}) = \chi(-1) W(\bar{\chi}),$$

so that

$$W(\chi) \overline{W(\chi)} = W(\chi) W(\bar{\chi}) \chi(-1) = m.$$

Thus (3) and (4) are proved. \square

Lemma 3.1.2. *Let χ, ψ be primitive Dirichlet characters, and m_χ, m_ψ their conductors. If $(m_\chi, m_\psi) = 1$, then*

$$W(\chi\psi) = \chi(m_\psi) \psi(m_\chi) W(\chi) W(\psi).$$

Proof. Put $m = m_\chi$ and $n = m_\psi$. By the assumption, for any integer a , there exist integers b, c such that

$$a = bn + cm.$$

The integers b, c are uniquely determined modulo m and n , respectively, and when a runs over all the representatives of $\mathbb{Z}/mn\mathbb{Z}$, so does the pair (b, c) over the representatives of $\mathbb{Z}/m\mathbb{Z} \times \mathbb{Z}/n\mathbb{Z}$. Therefore we see

$$\begin{aligned} W(\chi\psi) &= \sum_{a=0}^{mn-1} (\chi\psi)(a) e^{2\pi i a/mn} \\ &= \left(\sum_{b=0}^{m-1} \chi(bn) e^{2\pi i b/m} \right) \left(\sum_{c=0}^{n-1} \psi(cm) e^{2\pi i c/n} \right) \\ &= \chi(m_\psi) \psi(m_\chi) W(\chi) W(\psi). \end{aligned} \quad \square$$

Lemma 3.1.3. (1) Let χ be a Dirichlet character mod m . Then for any integers $l (> 0)$ and q , we have

$$\sum_{a=0}^{lm-1} \chi(a)e^{2\pi iaq/lm} = \begin{cases} 0 & \text{if } l \nmid q, \\ l \sum_{a=0}^{m-1} \chi(a)e^{2\pi iar/m} & (r = q/l) \text{ if } l|q. \end{cases}$$

(2) Let χ be a primitive Dirichlet character mod m , and χ' the Dirichlet character mod lm induced from χ . Then for an integer q , we have

$$\sum_{a=0}^{lm-1} \chi'(a)e^{2\pi iaq/lm} = W(\chi) \sum_{0 < c|(l, q)} c\mu(l/c)\chi(l/c)\bar{\chi}(q/c),$$

where μ is the Möbius function.

Proof. We see that

$$\begin{aligned} \sum_{a=0}^{lm-1} \chi(a)e^{2\pi iaq/lm} &= \sum_{d=0}^{m-1} \chi(d)e^{2\pi idq/lm} \sum_{b=0}^{l-1} e^{2\pi ibq/l} \quad (a = bm + d) \\ &= \begin{cases} 0 & \text{if } l \nmid q, \\ l \sum_{d=0}^{m-1} \chi(d)e^{2\pi idr/m} & \text{if } l|q. \end{cases} \end{aligned}$$

This implies (1). Furthermore if χ is primitive, then we see by Lemma 3.1.1 that

$$(3.1.6) \quad \sum_{a=0}^{lm-1} \chi(a)e^{2\pi iaq/lm} = \begin{cases} 0 & \text{if } l \nmid q, \\ lW(\chi)\bar{\chi}(q/l) & \text{if } l|q. \end{cases}$$

Now we see

$$\begin{aligned} \sum_{a=0}^{lm-1} \chi'(a)e^{2\pi iaq/lm} &= \sum_{a=0}^{lm-1} \left(\sum_{0 < d|(a, l)} \mu(d) \right) \chi(a)e^{2\pi iaq/lm} \\ &= \sum_{0 < d|l} \mu(d)\chi(d) \sum_{n=0}^{mc-1} \chi(n)e^{2\pi inq/mc}, \end{aligned}$$

where $l = cd$, $a = nd$. Applying (3.1.6) to the last sum, we obtain (2). □

Let p be an odd prime number. For integers n , we put

$$(3.1.7) \quad \left(\frac{n}{p}\right) = \begin{cases} 1 & \text{if } p \nmid n \text{ and } x^2 \equiv n \pmod p \text{ is solvable in } \mathbb{Z}, \\ -1 & \text{if } p \nmid n \text{ and } x^2 \equiv n \pmod p \text{ is unsolvable in } \mathbb{Z}, \\ 0 & \text{if } p|n. \end{cases}$$

We call $\left(\frac{n}{p}\right)$ the *quadratic residue symbol*, or the *Legendre symbol*. The mapping “ $n \mapsto \left(\frac{n}{p}\right)$ ” is a Dirichlet character mod p . We generalize the quadratic residue symbol and define $\left(\frac{a}{b}\right)$ for integers a and b ($(a, b) \neq (0, 0)$). When b is an odd prime

number, we define $\left(\frac{a}{b}\right)$ by (3.1.7). Next if b is 2, ± 1 , or 0, we put

$$(3.1.8) \quad \begin{aligned} \left(\frac{a}{2}\right) &= \begin{cases} 1 & \text{if } a \equiv 1 \pmod{8}, \\ -1 & \text{if } a \equiv 5 \pmod{8}, \\ 0 & \text{otherwise,} \end{cases} \\ \left(\frac{a}{-1}\right) &= \begin{cases} 1 & \text{if } a \geq 0, \\ -1 & \text{if } a < 0, \end{cases} \\ \left(\frac{a}{1}\right) &= 1, \\ \left(\frac{a}{0}\right) &= \begin{cases} 1 & \text{if } a = 1, \\ 0 & \text{if } a \neq 1. \end{cases} \end{aligned}$$

In general, let b be a nonzero integer. Express b as the product of ± 1 and prime numbers

$$b = \varepsilon \Pi p \quad (\varepsilon = \pm 1, \quad p: \text{prime}),$$

and put

$$(3.1.9) \quad \left(\frac{a}{b}\right) = \left(\frac{a}{\varepsilon}\right) \prod_p \left(\frac{a}{p}\right).$$

We call $\left(\frac{a}{b}\right)$ the *Kronecker symbol*. The following theorem on quadratic fields is well known (see, for example, [Borevich–Shafarevich]).

Theorem 3.1.4. *Let $F = \mathbb{Q}(\sqrt{m})$ be a quadratic field with a square-free integer m . For any prime number p , we have:*

- (1) if $\left(\frac{m}{p}\right) = 1$, then p splits in F ;
- (2) if $\left(\frac{m}{p}\right) = -1$, then p remains prime in F ;
- (3) if $\left(\frac{m}{p}\right) = 0$, then p ramifies in F .

Now let $F = \mathbb{Q}(\sqrt{m})$ be a quadratic field as in Theorem 3.1.4, and d the discriminant of F (for the definition of the discriminant, see §3.3). Then we have

$$d = \begin{cases} m & \text{if } m \equiv 1 \pmod{4}, \\ 4m & \text{if } m \not\equiv 1 \pmod{4}, \end{cases}$$

so that $\left(\frac{m}{p}\right) = \left(\frac{d}{p}\right)$ for odd p . We note that when d is the discriminant of some quadratic field, $\left(\frac{d}{b}\right)$ coincides with the classical one. The following properties are well known.

(3.1.10) For any integer $d (\neq 0)$, the mapping " $n \mapsto \left(\frac{d}{n}\right)$ " is a Dirichlet character, and if d is the discriminant of a quadratic field, then " $n \mapsto \left(\frac{d}{n}\right)$ " is a primitive Dirichlet character of conductor $|d|$.

(3.1.11) If p is a prime number, -1 , or -2 , then we put

$$p^* = \begin{cases} p & \text{if } p \equiv 1 \pmod{4}, \\ -p & \text{if } p \equiv -1 \pmod{4} \quad \text{and } p \neq -1, \\ -4 & \text{if } p = -1, \\ 8 & \text{if } p = 2, \\ -8 & \text{if } p = -2. \end{cases}$$

Then an integer d is the discriminant of a quadratic field if and only if d is a product of distinct p^* 's. In this case, if $d = \Pi p^*$, then

$$\left(\frac{d}{a}\right) = \Pi \left(\frac{p^*}{a}\right) \quad (a \in \mathbb{Z}).$$

(3.1.12) If p is an odd prime, then $\left(\frac{p^*}{a}\right) = \left(\frac{a}{p}\right)$ for any integer a .

The last property is called the *Gaussian reciprocity law*.

§3.2. The Riemann Zeta-Function

For a sequence $\{a_n\}_{n=1}^{\infty}$ of complex numbers, we put

$$\phi(s) = \sum_{n=1}^{\infty} a_n n^{-s} \quad (s \in \mathbb{C}),$$

and call it a *Dirichlet series*. In particular, when $a_n = 1$ for all $n \geq 1$, we write

$$\zeta(s) = \sum_{n=1}^{\infty} n^{-s},$$

and call it the *Riemann zeta-function*. Since for any $\varepsilon > 0$,

$$\sum_{n=1}^{\infty} |n^{-s}| \leq 1 + \int_1^{\infty} x^{-(1+\varepsilon)} dx < \infty$$

provided $\operatorname{Re}(s) \geq 1 + \varepsilon$, $\zeta(s)$ is convergent absolutely and uniformly on $\operatorname{Re}(s) \geq 1 + \varepsilon$. Hence $\zeta(s)$ is holomorphic on $\operatorname{Re}(s) > 1$. Let us show that $\zeta(s)$ has the infinite product expansion

$$\zeta(s) = \prod_p (1 - p^{-s})^{-1},$$

where p runs over all prime numbers. In fact, let ε be a positive number. Then for any positive integer m , we see

$$|\zeta(s) - \prod_{p < m} (1 - p^{-s})^{-1}| \leq \sum_{n \geq m} n^{-(1+\varepsilon)}$$

on $\operatorname{Re}(s) \geq 1 + \varepsilon$. Since the right-hand side converges to 0 when $m \rightarrow \infty$, $\prod_{p < m} (1 - p^{-s})^{-1}$ converges to $\zeta(s)$ on $\operatorname{Re}(s) \geq 1 + \varepsilon$. Since ε is arbitrary, the infinite product expansion holds on $\operatorname{Re}(s) > 1$. More generally, if a Dirichlet series $\phi(s)$ is convergent on a complex domain and has an infinite product expansion of the form

$$\phi(s) = \prod_p \phi_p(s),$$

with a meromorphic function $\phi_p(s)$ of p^{-s} , we say that $\phi(s)$ has an *Euler product*.

Lemma 3.2.1. *Assume that both $\sum_{n=1}^{\infty} a_n n^{-s}$ and $\sum_{n=1}^{\infty} b_n n^{-s}$ are absolutely convergent at $s = \sigma_0 (> 0)$. If $\sum_{n=1}^{\infty} a_n n^{-s} = \sum_{n=1}^{\infty} b_n n^{-s}$ on $\operatorname{Re}(s) \geq \sigma_0$, then $a_n = b_n$ for all n .*

Proof. It is sufficient to show that if $\sum_{n=1}^{\infty} a_n n^{-s} = 0$, then $a_n = 0$ for all n . Since $\sum_{n=1}^{\infty} a_n n^{-s}$ is absolutely convergent at $s = \sigma_0$, it converges absolutely and uniformly on $\operatorname{Re}(s) \geq \sigma_0$. Let m be the smallest integer such that $a_m \neq 0$. Since we have $(n/m)^{-\sigma} < n^{-\sigma/2}$ for $n > m^2$ and $\sigma > 0$, we see

$$\begin{aligned} |a_m| &\leq \sum_{n=m+1}^{\infty} |a_n| (n/m)^{-\sigma} \\ &\leq \sum_{n=m+1}^{m^2} |a_n| (n/m)^{-\sigma} + \sum_{n=m^2+1}^{\infty} |a_n| n^{-\sigma/2} \quad (\sigma \geq \sigma_0). \end{aligned}$$

Take a sufficiently large N so that

$$\sum_{n=N+1}^{\infty} |a_n| n^{-\sigma_0} \leq |a_m|/3,$$

and take $\sigma > 2\sigma_0$ so that

$$\sum_{n=m+1}^{m^2} |a_n| (n/m)^{-\sigma} + \sum_{n=m^2+1}^N |a_n| n^{-\sigma/2} \leq |a_m|/3.$$

Then $|a_m| \leq \frac{2}{3}|a_m|$; this is a contradiction. □

Let now K be any commutative ring, and \tilde{K} the ring of all formal power series over K with variables u_p for all prime numbers p , or

$$\tilde{K} = K[[u_p \mid p: \text{prime numbers}]].$$

We call elements of \tilde{K} *formal Dirichlet series*. For the prime factor decomposition $n = \prod_p p^e$, write

$$n^{-s} = \prod_p u_p^e, \quad 1^{-s} = 1.$$

Then any element of \tilde{K} can be expressed as

$$\phi(s) = \sum_{n=1}^{\infty} a_n n^{-s}$$

with a sequence $\{a_n\}$ of K . Let $\phi_p(s)$ be an element in $K[[u_p]]$ for each p . Assume

$$\phi_p(s) = 1 + (\text{a formal power series in } u_p \text{ of degree } \geq 1)$$

for almost all p . Then the product $\prod_p \phi_p(s)$ is meaningful in K . When a formal Dirichlet series $\phi(s)$ can be written as the product

$$\phi(s) = \prod_p \phi_p(s) \quad (\phi_p(s) \in K[[u_p]])$$

in \tilde{K} , we say that $\phi(s)$ has a *formal Euler product*. Formal Dirichlet series and formal Euler products are useful to state relations among numbers a_n .

In general, Dirichlet series appearing in number theory can be analytically continued to the whole complex plane and satisfy functional equations. We study these for the Riemann zeta-function. For $s \in \mathbb{C}$ such that $\operatorname{Re}(s) > 0$, we put

$$\Gamma(s) = \int_0^{\infty} e^{-t} t^{s-1} dt.$$

When $\operatorname{Re}(s) \geq \varepsilon$, $1 > \varepsilon > 0$, we see

$$e^{-t} t^{s-1} = \begin{cases} O(e^{-(1-\varepsilon)t}) & (t \rightarrow \infty), \\ O(t^{s-1}) & (t \rightarrow 0). \end{cases}$$

Then $\Gamma(s)$ is convergent absolutely and uniformly on $\operatorname{Re}(s) \geq \varepsilon$. Hence $\Gamma(s)$ is a holomorphic function on $\operatorname{Re}(s) > 0$. By definition, $\Gamma(s+1) = s\Gamma(s)$ on $\operatorname{Re}(s) > 0$. Therefore by putting

$$\Gamma(s) = s^{-1} \Gamma(s+1) \quad (\operatorname{Re}(s) > -1),$$

$\Gamma(s)$ becomes a meromorphic function defined on $\operatorname{Re}(s) > -1$. Repeating this procedure, $\Gamma(s)$ is continued to a meromorphic function on the whole s -plane. We call $\Gamma(s)$ the *Γ -function*. For complex numbers $z (\neq 0)$ and s , we put

$$(3.2.1) \quad z^s = e^{s(\log|z| + i\arg(z))} \quad (-\pi < \arg(z) \leq \pi).$$

The following properties of $\Gamma(s)$ are well known (for the proofs, see, for example, [Ahlfors]):

$$(3.2.2) \quad \Gamma(s+1) = s\Gamma(s), \quad \Gamma(n) = (n-1)! \quad (n \geq 1);$$

(3.2.3) $\Gamma(s)$ is entire except for simple poles $s = -n$ ($n = 0, 1, \dots$) with residue $(-1)^n/n!$, and has no zeros;

$$(3.2.4) \quad \Gamma(s)\Gamma(1-s) = \pi/\sin(\pi s), \quad \Gamma(1/2) = \sqrt{\pi};$$

(3.2.5) for $a, s \in \mathbb{C}$ such that $\operatorname{Re}(a) > 0, \operatorname{Re}(s) > 0,$

$$\int_0^\infty e^{-at} t^{s-1} dt = a^{-s} \Gamma(s);$$

(3.2.6) (Legendre's relation) $2^{2s-1} \Gamma(s) \Gamma(s + \frac{1}{2}) = \sqrt{\pi} \Gamma(2s);$

(3.2.7) (Stirling's formula) $\Gamma(s) = \sqrt{2\pi} s^{s-1/2} e^{-s+\mu(s)},$ where $\mu(s)$ is a function such that

$$\mu(s) \rightarrow 0 \quad (|s| \rightarrow \infty)$$

uniformly on $\operatorname{Re}(s) \geq \sigma_0 > 0;$

(3.2.8) (Stirling's estimate) $\Gamma(s) \sim \sqrt{2\pi} \tau^{\sigma-1/2} e^{-\pi|\tau|/2} \quad (s = \sigma + it, \quad |\tau| \rightarrow \infty),$

uniformly on any vertical strip $v_1 \leq \sigma \leq v_2;$

(3.2.9) (Euler–Gauss) $\Gamma(s) = \lim_{n \rightarrow \infty} \frac{n! n^s}{s(s+1) \cdots (s+n)} \quad (0 < s \in \mathbb{R}).$

Theorem 3.2.2. (1) Put

$$\Lambda(s) = \pi^{-s/2} \Gamma(s/2) \zeta(s).$$

Then $\Lambda(s) + \frac{1}{s} + \frac{1}{1-s}$ can be holomorphically continued to the whole s -plane, and we have the functional equation

$$\Lambda(s) = \Lambda(1-s).$$

(2) $\zeta(s) - \frac{1}{s-1}$ is entire.

Proof. By definition, we see, on $\operatorname{Re}(s) > 1,$

$$\begin{aligned} (3.2.10) \quad \Lambda(2s) &= \sum_{n=1}^\infty (\pi n^2)^{-s} \int_0^\infty e^{-t} t^{s-1} dt \\ &= \sum_{n=1}^\infty \int_0^\infty e^{-\pi n^2 t} t^{s-1} dt \\ &= \int_0^\infty \left(\sum_{n=1}^\infty e^{-\pi n^2 t} \right) t^{s-1} dt. \end{aligned}$$

Here we can exchange the order of integration and summation since $\sum_{n=1}^\infty e^{-\pi n^2 t} |t^{s-1}|$ is integrable. Since for $f(x) = e^{-\pi x^2 t}, \sum_{n=-\infty}^\infty f(x+n)$ is uniformly convergent, the Poisson summation formula implies

$$\sum_{n=-\infty}^\infty e^{-\pi n^2 t} = \frac{1}{\sqrt{t}} \sum_{n=-\infty}^\infty e^{-\pi n^2/t}.$$

Put $\omega(t) = \sum_{n=-\infty}^{\infty} e^{-\pi n^2 t}$, then $\omega(t) = \frac{1}{\sqrt{t}} \omega(1/t)$, so that

$$\begin{aligned} \Lambda(2s) &= \int_0^{\infty} \frac{1}{2} (\omega(t) - 1) t^{s-1} dt \\ &= \int_0^1 \frac{1}{2} \left(\frac{1}{\sqrt{t}} \omega(1/t) - 1 \right) t^{s-1} dt + \int_1^{\infty} \frac{1}{2} (\omega(t) - 1) t^{s-1} dt \\ &= \int_1^{\infty} \frac{1}{2} (t^{1/2-s} + t^s) (\omega(t) - 1) t^{-1} dt - \frac{1}{2s} - \frac{1}{1-2s}. \end{aligned}$$

Since $\omega(t) - 1 = O(e^{-\pi t})$ ($t \rightarrow \infty$), the last integral is convergent uniformly on any compact subset of the s -plane. Therefore it is an entire function of s . Defining $\Lambda(2s)$ for any s by the last integral, we obtain the analytic continuation of $\Lambda(s)$. In particular, $\Lambda(s) + \frac{1}{s} + \frac{1}{1-s}$ is holomorphic on the whole s -plane. Moreover the last integral is invariant under the transformation " $s \mapsto 1/2 - s$ ". Therefore we obtain the functional equation. The second assertion follows from (1) and (3.2.3). \square

More generally, for a function $f(t)$ on $\mathbb{R}_+ = \{x \in \mathbb{R} \mid x > 0\}$, put

$$(3.2.11) \quad \lambda(s) = \int_0^{\infty} f(t) t^{s-1} dt.$$

If this integral is convergent on some domain, we call $\lambda(s)$ the *Mellin transform* of $f(t)$. By (3.2.10), $\Lambda(2s)$ is the Mellin transform of $\frac{1}{2}(\omega(t) - 1)$. Let now $t = e^x$, and put $s = \sigma + it$, then we can rewrite

$$\lambda(\sigma + it) = \int_{-\infty}^{\infty} f(e^x) e^{(\sigma + it)x} dx,$$

that is, $\lambda(\sigma + it)$ is nothing but the Fourier transform of $f(e^x)e^{\sigma x}$ for a fixed σ . Therefore the Mellin transform of $f(t)$ is meaningful for σ such that $F(x) = f(e^x)e^{\sigma x}$ is a Schwarz function; in other words, $F(x)$ is a C^∞ -function and satisfies for any positive integers m and n ,

$$(3.2.12) \quad \sup_x \left| x^n \frac{d^m F(x)}{dx^m} \right| < \infty.$$

Conversely, $f(t)$ can be obtained by the *Mellin inverse transform*

$$(3.2.13) \quad f(t) = \frac{1}{2\pi i} \int_{\operatorname{Re}(s)=\sigma} \lambda(s) t^{-s} ds$$

by the general theory of the Fourier transform. Now take e^{-t} for $f(t)$. Since $f(e^x)e^{\sigma x}$ is a Schwarz function for $\sigma > 0$, we have

$$(3.2.14) \quad e^{-t} = \frac{1}{2\pi i} \int_{\operatorname{Re}(s)=\sigma} \Gamma(s) t^{-s} ds \quad (\sigma > 0).$$

Also by taking $\frac{1}{2}(\omega(t) - 1)$ for $f(t)$, by (3.2.10), we have

$$(3.2.15) \quad \frac{1}{2}(\omega(t) - 1) = \frac{1}{2\pi i} \int_{\text{Re}(s)=\sigma} \Lambda(2s)t^{-s} ds \quad (\sigma > 1).$$

Hence $\frac{1}{2}(\omega(t) - 1)$ corresponds to $\Lambda(2s)$ by the Mellin transform.

We now define the *theta function* $\theta(z)$ by

$$(3.2.16) \quad \theta(z) = \sum_{n=-\infty}^{\infty} e^{2\pi i n^2 z} \quad (z \in \mathbf{H}).$$

Since the right-hand side of (3.2.16) is convergent uniformly on any compact subset of \mathbf{H} , $\theta(z)$ is a holomorphic function on \mathbf{H} . By the equality $\omega(t) = \frac{1}{\sqrt{t}} \omega(1/t)$ and the holomorphy of $\theta(z)$, we have the *transformation formula*

$$(3.2.17) \quad \theta(-1/4z) = (2z/i)^{1/2} \theta(z).$$

As was shown above, this transformation formula is equivalent to the functional equation of the Riemann zeta-function. Hecke generalized this equivalence to the equivalence between functional equations of Dirichlet series and automorphy of functions on \mathbf{H} , which is one of the main topics in Chapter 4.

We conclude this section by calculating the values of $\zeta(s)$ at positive even integers, which we need later. Put

$$F(t) = \frac{te^t}{e^t - 1},$$

and let

$$(3.2.18) \quad F(t) = \sum_{m=0}^{\infty} \frac{B_m}{m!} t^m$$

be its Taylor expansion. The coefficient B_m is called the *m-th Bernoulli number*. It is obvious that

$$B_m \in \mathbb{Q}, \quad B_0 = 1.$$

Since $F(-t) = F(t) - t$, we see

$$B_1 = 1/2,$$

$$B_m = 0 \quad \text{if } m (> 1) \text{ is odd.}$$

Now we see easily

$$(3.2.19) \quad z \cot(z) = iz \frac{e^{iz} + e^{-iz}}{e^{iz} - e^{-iz}} = iz + \frac{2ize^{-2iz}}{1 - e^{-2iz}}.$$

Comparing this with the well known partial fraction expansion

$$(3.2.20) \quad \cot(z) = \frac{1}{z} + \sum_{n=1}^{\infty} \frac{2z}{z^2 - n^2\pi^2},$$

and putting $t = -2iz$, we have

$$F(t) = 1 + \frac{t}{2} + 2 \sum_{n=1}^{\infty} \frac{t^2}{t^2 + (2\pi n)^2} \quad (t \neq 2n\pi i, \quad n \in \mathbb{Z}).$$

Since

$$\frac{t^2}{t^2 + (2\pi n)^2} = \sum_{m=1}^{\infty} (-1)^{m-1} \left(\frac{t}{2\pi n}\right)^{2m},$$

we have

$$F(t) = 1 + \frac{t}{2} + 2 \sum_{n=1}^{\infty} \sum_{m=1}^{\infty} (-1)^{m-1} \frac{t^{2m}}{(2\pi n)^{2m}}.$$

The right-hand side is absolutely convergent, and therefore, we can exchange the order of summation. Thus we see

$$F(t) = 1 + \frac{t}{2} + \sum_{m=1}^{\infty} (-1)^{m-1} \frac{2\zeta(2m)}{(2\pi)^{2m}} t^{2m}.$$

Comparing this with (3.2.18), we know the values of $\zeta(2m)$. This combined with the functional equation implies

Theorem 3.2.3. *For an integer m , we have*

$$\zeta(2m) = \frac{-(2\pi i)^{2m}}{2(2m)!} B_{2m} \quad (m \geq 0),$$

and

$$\zeta(1 - 2m) = -B_{2m}/2m \quad (m \geq 1).$$

We give the values of the first eight Bernoulli numbers B_m for even m (see [Washington]):

$$B_2 = \frac{1}{6} \quad B_4 = -\frac{1}{30} \quad B_6 = \frac{1}{42} \quad B_8 = -\frac{1}{30} \quad B_{10} = \frac{5}{66}$$

$$B_{12} = -\frac{691}{2730} \quad B_{14} = \frac{7}{6} \quad B_{16} = -\frac{3617}{510}.$$

§ 3.3. Hecke *L*-Functions

In this section, we recall some results from number fields and Hecke *L*-functions which are necessary later. Let F be a number field of degree g , and τ_1, \dots, τ_g all the isomorphisms of F into \mathbb{C} , and put $F_v = F^{\tau_v}$, $a_v = a^{\tau_v}$ for any $a \in F$. The isomorphism τ_v is called *real* or *imaginary*, if $F_v \subset \mathbb{R}$ or not, respectively. Hereafter we assume that

- (i) if $v \leq r_1$, then τ_v is real,
- (ii) if $r_1 + 1 \leq v$, then τ_v is imaginary, and $a_v = \bar{a}_{v+r_2}$ for $a \in F$ ($r_1 + 1 \leq v \leq r_1 + r_2$).

Here $g = r_1 + 2r_2$. We say that F is *totally real* if $r_1 = g$, and that F is *totally imaginary* if $r_1 = 0$. Let $r_F \subset F$ be the ring of integers of F , I the group of fractional ideals of F , and P the subgroup of I consisting of all principal ideals. Then the quotient group I/P is of finite order and is called the *ideal class group* of F . We denote the order of I/P by $h(F)$ and call it the *class number of F* . For a non-zero integral ideal \mathfrak{m} of r_F , we put

$$I(\mathfrak{m}) = \{ \mathfrak{a} \in I \mid (\mathfrak{a}, \mathfrak{m}) = 1 \},$$

$$P(\mathfrak{m}) = \{ (a) \in P \mid a \equiv 1 \pmod{\times \mathfrak{m}} \},$$

where $\pmod{\times}$ indicates the multiplicative congruence. Let ξ be a character of $I(\mathfrak{m})$ into \mathbb{C}^\times . We call ξ a *Hecke character mod \mathfrak{m}* if

$$(3.3.1) \quad \xi((a)) = \prod_{v=1}^{r_1+r_2} (a_v/|a_v|)^{u_v} |a_v|^{iv_v} \quad \text{for } (a) \in P(\mathfrak{m}),$$

with real numbers $u_v, v_v (1 \leq v \leq r_1 + r_2)$ such that

- (i) $u_v \in \begin{cases} \{0, 1\} & (v \leq r_1), \\ \mathbb{Z} & (r_1 + 1 \leq v), \end{cases}$
- (ii) $\sum_{v=1}^{r_1+r_2} v_v = 0$.

For a Hecke character $\xi \pmod{\mathfrak{m}}$, put

$$\mathbf{M} = \{ \mathfrak{n}: \text{integral ideal of } F \mid (3.3.1) \text{ holds for } (a) \in P(\mathfrak{n}) \cap I(\mathfrak{m}) \}.$$

We call the greatest common ideal \mathfrak{m}_ξ of elements of \mathbf{M} the *conductor of ξ* . When $\mathfrak{m} = \mathfrak{m}_\xi$, ξ is called *primitive*. For any Hecke character $\xi \pmod{\mathfrak{m}}$, there uniquely exists a primitive Hecke character $\xi^0 \pmod{\mathfrak{m}_\xi}$ satisfying

$$(3.3.2) \quad \xi^0(\mathfrak{n}) = \xi(\mathfrak{n}) \quad \text{if } \mathfrak{n} \in I(\mathfrak{m}).$$

Furthermore when u_v and v_v satisfy the additional conditions

- (iii) $u_v = 0 \quad (r_1 + 1 \leq v \leq r_1 + r_2),$
- (iv) $v_v = 0 \quad (1 \leq v \leq r_1 + r_2),$

a Hecke character ξ is called a *class character*. We can extend a Hecke character ξ to a mapping of I into \mathbb{C} by defining $\xi(\mathfrak{a}) = 0$ if $\mathfrak{a} \notin I(\mathfrak{m})$.

Now we define the *Hecke L-function* for ξ by

$$(3.3.3) \quad L(s, \xi) = \sum_{\mathfrak{a}} \xi(\mathfrak{a}) N(\mathfrak{a})^{-s} \quad (s \in \mathbb{C}),$$

where \mathfrak{a} runs over all non-zero integral ideals of r_F , and $N(\mathfrak{a}) = N_F(\mathfrak{a})$ is the (absolute) norm of \mathfrak{a} , namely, $N_F(\mathfrak{a}) = |r_F/\mathfrak{a}|$. Using the convergence of the Riemann zeta-function, we see easily that $L(s, \xi)$ is convergent absolutely and uniformly on the set $\text{Re}(s) \geq 1 + \varepsilon$, for any $\varepsilon > 0$, and has the Euler product

$$(3.3.4) \quad L(s, \xi) = \prod_{\mathfrak{p}} (1 - \xi(\mathfrak{p}) N(\mathfrak{p})^{-s})^{-1},$$

where \mathfrak{p} runs over all prime ideals of r_F . In particular, when ξ is the trivial character ξ_0 , we write

$$(3.3.5) \quad \zeta_F(s) = L(s, \xi_0) = \sum_{\mathfrak{a}} N(\mathfrak{a})^{-s} = \prod_{\mathfrak{p}} (1 - N(\mathfrak{p})^{-s})^{-1},$$

and call it the *Dedekind zeta-function* of F . When $F = \mathbb{Q}$, it is nothing but the Riemann zeta-function.

Hecke obtained the functional equation for any Hecke L -function by generalizing the proof for the Riemann zeta-function described in the previous section ([Hecke]). Before we state the functional equation, let us define the Gauss sum of a Hecke character. We denote by $\text{tr} = \text{tr}_F$ the trace mapping of F into \mathbb{Q} , and put

$$\mathfrak{D}^{-1} = \{a \in F \mid \text{tr}(ab) \in \mathbb{Z} \text{ for all } b \in r_F\}.$$

Then \mathfrak{D}^{-1} is a fractional ideal of F and the inverse $\mathfrak{D} = \mathfrak{D}(F)$ of \mathfrak{D}^{-1} is an integral ideal. We call $\mathfrak{D}(F)$ the *different* of F . For a basis $\{\alpha_1, \dots, \alpha_g\}$ of r_F over \mathbb{Z} , we put

$$d_F = \det[\text{tr}(\alpha_\nu \alpha_\mu)] \quad (\in \mathbb{Z}),$$

and call it the *discriminant* of F .

Now let ξ be a primitive Hecke character of conductor m with u_ν, v_ν . We put, for $a \in F$ ($a \neq 0$),

$$(3.3.6) \quad \xi_\infty(a) = \prod_{\nu=1}^{r_1+r_2} (a_\nu / |a_\nu|)^{u_\nu} |a_\nu|^{iv_\nu},$$

$$(3.3.7) \quad \xi_f(a) = \xi((a)) \xi_\infty(a)^{-1}.$$

If $a \equiv b \pmod m$, then $\xi_f(a) = \xi_f(b)$. Let c be an integral ideal of F such that $\mathfrak{D}mc$ is principal and $(m, c) = 1$. Take an element b of r_F so that $\mathfrak{D}mc = (b)$, and define the *Gauss sum* $W(\xi)$ of ξ by

$$(3.3.8) \quad W(\xi) = \frac{\xi_\infty(b)}{\xi(c)} \sum_a \xi_f(a) e^{2\pi i \text{tr}(a/b)},$$

where a runs over a complete set of representatives for c/mc . The value $W(\xi)$ is independent of the choice of c, b and a set of representatives. By a similar argument as in Lemma 3.1.1, we have:

$$(3.3.9) \quad |W(\xi)|^2 = N(m);$$

(3.3.10) *let ξ, η be two primitive Hecke characters of conductor m and n , respectively. If $(m, n) = 1$, then*

$$(3.3.11) \quad W(\xi\eta) = \xi(n)\eta(m)W(\xi)W(\eta).$$

For a Hecke character $\xi \pmod m$, we put

$$\bar{\xi}(a) = \overline{\xi(a)} \quad (a \in I),$$

then $\bar{\xi}$ is also a Hecke character $\pmod m$. To state the functional equation for a

Hecke L -function $L(s, \xi)$, we put

$$(3.3.12) \quad \Lambda(s, \xi) = \left(\frac{2^{r_1} |d_F| N(\mathfrak{m})}{(2\pi)^g} \right)^{s/2} \prod_{v=1}^{r_1+r_2} \Gamma \left(\frac{n_v s + |u_v| + i v_v}{2} \right) L(s, \xi),$$

where

$$n_v = \begin{cases} 1 & (v \leq r_1), \\ 2 & (r_1 + 1 \leq v). \end{cases}$$

Now the functional equation for a Hecke L -function is as follows.

Theorem 3.3.1. *Let ξ be a primitive Hecke character of conductor \mathfrak{m} .*

(1) $\Lambda(s, \xi)$ is analytically continued to a meromorphic function on the whole s -plane, and satisfies the functional equation

$$\Lambda(1-s, \xi) = T(\xi) \Lambda(s, \bar{\xi}),$$

where

$$T(\xi) = 2^{iv} i^{-u} W(\xi) / N(\mathfrak{m})^{1/2},$$

$$u = \sum_{v=1}^{r_1+r_2} u_v, \quad v = \sum_{v=1}^{r_1+r_2} v_v.$$

(2) If ξ is the trivial character, then $\Lambda(s, \xi)$ is holomorphic except for simple poles at $s = 0$ and $s = 1$; otherwise $\Lambda(s, \xi)$ is entire. The function $\Lambda(s, \xi)$ is bounded on any set of the form

$$\{s \in \mathbb{C} \mid a \leq \operatorname{Re}(s) \leq b, |\operatorname{Im}(s)| \geq c\} \quad (a < b, c > 0).$$

(3) $L(s, \xi)$ is entire if ξ is not trivial. If ξ is trivial, then it is holomorphic except for a simple pole at $s = 1$ with residue

$$\frac{2^{r_1+r_2} \pi^{r_2} R_h(F)}{w \sqrt{|d_F|}},$$

where w is the number of roots of unity contained in F , and R the regulator of F .

Now we consider particularly the case when $F = \mathbb{Q}$. Let χ be a Dirichlet character mod m . For a fractional ideal $\mathfrak{a} = (a)(b)^{-1}$ ($a, b \in \mathbb{Z}$, $a, b > 0$), we put

$$\hat{\chi}(\mathfrak{a}) = \chi(a) \overline{\chi(b)}.$$

Then $\hat{\chi}$ is a Hecke character and a class character. Any Hecke character of \mathbb{Q} is obtained from a Dirichlet character in this way. We identify them. For a Dirichlet character χ mod N , the Hecke L -function of χ

$$(3.3.13) \quad L(s, \chi) = \sum_{n=1}^{\infty} \chi(n) n^{-s} = \prod_p (1 - \chi(p) p^{-s})^{-1}$$

is called the *Dirichlet L -function* of χ . We also write the L -function as $L_N(s, \chi)$ in place of $L(s, \chi)$, when we wish to emphasize the modulus N of χ . If χ^0 is the primitive

character associated with χ , then

$$(3.3.14) \quad L_N(s, \chi) = \prod_{p|N} (1 - \chi^0(p)p^{-s}) \cdot L(s, \chi^0).$$

We restate the functional equation of Theorem 3.3.1 for Dirichlet L -functions. This is necessary in Chapter 4. For a Dirichlet character χ , we let

$$(3.3.15) \quad \delta_\chi = \begin{cases} 0 & \text{if } \chi(-1) = 1, \\ 1 & \text{if } \chi(-1) = -1. \end{cases}$$

Corollary 3.3.2. *Let χ be a primitive Dirichlet character of conductor m , and $\delta = \delta_\chi$. Put*

$$\Lambda(s, \chi) = (\pi/m)^{-s/2} \Gamma\left(\frac{s+\delta}{2}\right) L(s, \chi).$$

Then $\Lambda(s, \chi)$ is meromorphic on the whole s -plane and is bounded on any set of the form

$$\{s \in \mathbb{C} \mid a \leq \operatorname{Re}(s) \leq b, |\operatorname{Im}(s)| \geq c\} \quad (a < b, 0 < c).$$

Moreover, $\Lambda(s, \chi)$ satisfies the functional equation

$$\Lambda(1-s, \chi) = \frac{W(\chi)}{i^\delta \sqrt{m}} \Lambda(s, \bar{\chi}).$$

If χ is not the trivial character, $\Lambda(s, \chi)$ is entire.

We can restate Theorem 3.1.4 by using Dirichlet L -functions and Dedekind zeta-functions as follows.

Theorem 3.3.3. *Let $F = \mathbb{Q}(\sqrt{d})$ be a quadratic field with discriminant d , and $\chi_d = \left(\frac{d}{\cdot}\right)$ the Kronecker symbol. Then we have*

$$\zeta_F(s) = \zeta(s) L(s, \chi_d).$$

In the previous section, we calculated the values of the Riemann zeta-function at positive even integers using Bernoulli numbers. Leopoldt generalized it to Dirichlet L -functions. Let χ be a primitive Dirichlet character of conductor m . We put

$$F_\chi(t) = \sum_{a=1}^m \frac{\chi(a) t e^{at}}{e^{mt} - 1},$$

and let

$$F_\chi(t) = \sum_{n=0}^{\infty} \frac{B_{n,\chi}}{n!} t^n$$

be the Taylor expansion. We call the coefficient $B_{n,\chi}$ the n -th generalized Bernoulli number associated with χ . It is obvious that

$$B_{n,\chi} \in \mathbb{Q}(\chi) = \mathbb{Q}(\chi(a) \mid a \in \mathbb{Z}).$$

When χ is the principal character, $B_{n,\chi}$ is nothing but the Bernoulli number B_n .

Theorem 3.3.4. *Let χ be a primitive Dirichlet character of conductor m and $\delta = \delta_\chi$. Let k be a positive integer.*

(1) *If $k \equiv \delta \pmod{2}$, then*

$$L(k, \chi) = (-1)^{1+(k-\delta)/2} \frac{W(\chi)}{2i^\delta} (2\pi/m)^k \frac{B_{k,\bar{\chi}}}{k!},$$

and

$$L(1-k, \chi) = -B_{k,\chi}/k.$$

(2) *If $k \not\equiv \delta \pmod{2}$, then $L(1-k, \chi) = 0$ except for $m = 1$ and $\chi = 1$.*

For the proof and further results, see [Iwasawa], or [Washington].

Chapter 4. Modular Groups and Modular Forms

In this chapter, we explain the general theory of modular forms. In §4.1, we discuss the full modular group $SL_2(\mathbb{Z})$ and modular forms with respect to $SL_2(\mathbb{Z})$, as an introduction to the succeeding sections. We define and study congruence modular groups in §4.2. In §4.3, we explain the relation between modular forms and Dirichlet series obtained by Hecke and Weil. As an application of §4.3, we prove the transformation equation of $\eta(z)$ in §4.4. We explain Hecke's theory of Hecke operators in §4.5 and define primitive forms in §4.6. In §4.7 and §4.8, we construct Eisenstein series and some cusp forms from Dirichlet series of number fields. In §4.9, we explain theta functions which are also useful for constructing modular forms.

§4.1. $SL_2(\mathbb{Z})$

We call $SL_2(\mathbb{Z})$ and its subgroups of finite index *modular groups*. We call $SL_2(\mathbb{Z})$ the *full modular group*. In this section, we restrict ourselves to $SL_2(\mathbb{Z})$ and give concrete examples of automorphic forms to provide a transparent prospect for the succeeding sections. In this section, we assume $\Gamma = SL_2(\mathbb{Z})$.

Theorem 4.1.1. $SL_2(\mathbb{Z})$ is generated by two elements $\begin{bmatrix} 1 & 1 \\ 0 & 1 \end{bmatrix}$ and $\begin{bmatrix} 0 & -1 \\ 1 & 0 \end{bmatrix}$.

Proof. Put $\tau = \begin{bmatrix} 1 & 1 \\ 0 & 1 \end{bmatrix}$, $\omega = \begin{bmatrix} 0 & -1 \\ 1 & 0 \end{bmatrix}$, and let Λ be the subgroup of $SL_2(\mathbb{Z})$ generated by τ and ω . Suppose $\Lambda \neq SL_2(\mathbb{Z})$. Since

$$\omega\tau^{-1}\omega^{-1} = \begin{bmatrix} 1 & 0 \\ 1 & 1 \end{bmatrix} \quad \text{and} \quad \omega^2 = -1,$$

all elements of the form $\begin{bmatrix} a & 0 \\ c & d \end{bmatrix}$ of $SL_2(\mathbb{Z})$ are contained in Λ . Therefore if we put

$$b_0 = \min \left\{ |b| \mid \begin{bmatrix} a & b \\ c & d \end{bmatrix} \in SL_2(\mathbb{Z}) - \Lambda \right\},$$

then $b_0 \neq 0$. Take an element $\gamma_0 = \begin{bmatrix} a_0 & b_0 \\ c_0 & d_0 \end{bmatrix}$ of $SL_2(\mathbb{Z}) - \Lambda$, and an integer n so

that $|a_0 - nb_0| < b_0$. Since

$$\gamma_0 \omega^{-1} \tau^n = \begin{bmatrix} -b_0 & a_0 - nb_0 \\ -d_0 & c_0 - nd_0 \end{bmatrix},$$

we get $\gamma_0 \omega^{-1} \tau^n \in \mathcal{A}$ by the assumption on b_0 . Hence $\gamma_0 \in \mathcal{A}$; this is a contradiction. \square

Theorem 4.1.2. (1) *The set*

$$F = \{z \in \mathbf{H} \mid |z| \geq 1 \text{ and } |\operatorname{Re}(z)| \leq 1/2\}$$

is a fundamental domain of Γ . (See Figure 4.1.1.)

(2) *We have $v(\Gamma \backslash \mathbf{H}) = \pi/3$. In particular, Γ is a Fuchsian group of the first kind.*

Proof. (1): Let z be any point of \mathbf{H} , and put $L = \{cz + d \mid c, d \in \mathbb{Z}\}$. Since L is a lattice in \mathbb{C} , any non-empty subset of L contains an element which has the minimal absolute value. In particular, there exists the minimal value among in the set $\{|j(\gamma, z)| \mid \gamma \in \Gamma\}$. Since $\operatorname{Im}(\gamma z) = \operatorname{Im}(z)/|j(\gamma, z)|^2$, there exists a point z_0 of \mathbf{H} which is equivalent to z by an element of Γ and satisfies that

$$(4.1.1) \quad \operatorname{Im}(z_0) \geq \operatorname{Im}(\gamma z_0) \quad \text{for all } \gamma \in \Gamma.$$

Put $\tau = \begin{bmatrix} 1 & 1 \\ 0 & 1 \end{bmatrix}$, then $\tau^m z = z + m$ for any integer m . Replacing z_0 with $\tau^m z_0$, if necessary, we may assume $|\operatorname{Re}(z_0)| \leq 1/2$. Take $\begin{bmatrix} 0 & -1 \\ 1 & 0 \end{bmatrix}$ as γ in (4.1.1), then

$$\operatorname{Im}(z_0) \geq \operatorname{Im}(-1/z_0) = \operatorname{Im}(z_0)/|z_0|^2,$$

so that $|z_0| \geq 1$. This implies $z_0 \in F$. Therefore $\mathbf{H} = \bigcup_{\gamma \in \Gamma} \gamma F$. Next put

$$U = \{z \in \mathbf{H} \mid |z| > 1 \text{ and } |\operatorname{Re}(z)| < 1/2\}.$$

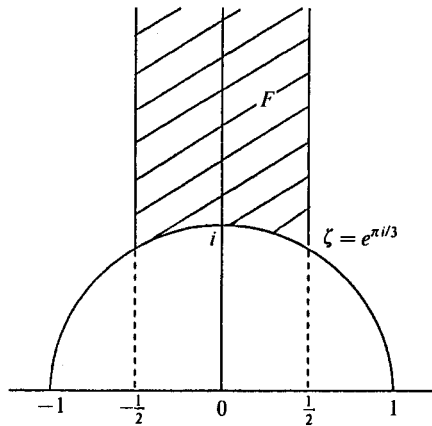

Fig. 4.1.1

Then $\bar{U} = F$. We are going to verify $\gamma U \cap U = \emptyset$ for $\gamma \neq \pm 1$. Let $\gamma = \begin{bmatrix} a & b \\ c & d \end{bmatrix}$ be an element of Γ such that $\gamma U \cap U \neq \emptyset$, and take an element $z \in U$ so that $\gamma z \in U$. We may assume $\text{Im}(\gamma z) \geq \text{Im}(z)$ by taking γ^{-1} in place of γ , if necessary. Then

$$(4.1.2) \quad |c|\text{Im}(z) \leq |cz + d| \leq 1.$$

Since z belongs to U , we have $\text{Im}(z) > \sqrt{3}/2$. Thus we get $|c| \leq 1$ noting that c is an integer. Suppose $|c| = 1$. Then $|z \pm d| \leq 1$ by (4.1.2). On the other hand, we have $|z \pm d| > 1$ for any integer d , since $z \in U$. This is a contradiction; thus $c = 0$, $\gamma = \pm \begin{bmatrix} 1 & b \\ 0 & 1 \end{bmatrix}$, and $\gamma z = z + b$. For an integer b , both z and $z + b$ belong to U if and only if $b = 0$. This implies $\gamma = \pm \begin{bmatrix} 1 & 0 \\ 0 & 1 \end{bmatrix}$. Consequently, F is a fundamental domain of Γ . (2): Since $v(\Gamma \backslash \mathbf{H}) = v(F)$, we get $v(\Gamma \backslash \mathbf{H}) = \pi/3$ by Lemma 1.4.4.

□

Theorem 4.1.3. (1) Any elliptic point of Γ is equivalent to $i = \sqrt{-1}$ or $\zeta = e^{\pi i/3}$. The point i is an elliptic point of order 2 and

$$\Gamma_i = \left\{ \pm \begin{bmatrix} 1 & 0 \\ 0 & 1 \end{bmatrix}, \pm \begin{bmatrix} 0 & -1 \\ 1 & 0 \end{bmatrix} \right\}.$$

The point ζ is an elliptic point of order 3 and

$$\Gamma_\zeta = \left\{ \pm \begin{bmatrix} 1 & 0 \\ 0 & 1 \end{bmatrix}, \pm \begin{bmatrix} 1 & -1 \\ 1 & 0 \end{bmatrix}, \pm \begin{bmatrix} 0 & -1 \\ 1 & -1 \end{bmatrix} \right\}.$$

- (2) The set P_Γ of the cusps of Γ is $\mathbb{Q} \cup \{\infty\}$, and all cusps of Γ are equivalent.
- (3) The genus of \mathfrak{R}_Γ is equal to 0.

Proof. (1): It is obvious that interior points of a fundamental domain are ordinary points. Thus any elliptic point must be equivalent to a boundary point of the fundamental domain F defined in Theorem 4.1.2. Since Γ contains

$$\tau = \begin{bmatrix} 1 & 1 \\ 0 & 1 \end{bmatrix} \quad \text{and} \quad \omega = \begin{bmatrix} 0 & -1 \\ 1 & 0 \end{bmatrix},$$

the boundary points of F , other than the three points i, ζ , and ζ' ($= e^{2\pi i/3}$), are also ordinary points. Observing that the interior angle of F at i is π , we see the order of i is at most 2. Since $\omega i = i$, and $\omega^2 = -1$, the point i is indeed an elliptic point of order 2. Since $\tau \zeta' = \zeta$ and the interior angles of F at ζ and ζ' are both $\pi/3$, the order of ζ is at most 3. Now we note

$$\tau\omega = \begin{bmatrix} 1 & -1 \\ 1 & 0 \end{bmatrix}, \quad (\tau\omega)^2 = \begin{bmatrix} 0 & -1 \\ 1 & -1 \end{bmatrix}, \quad \text{and} \quad (\tau\omega)^3 = -1.$$

Since $\tau\omega$ fixes ζ , ζ is an elliptic point of order 3, and ζ' is equivalent to ζ . (2): It is obvious that the point ∞ is a cusp of Γ . Let x ($\neq \infty$) be a cusp of Γ . Since x is a

double root of a quadratic equation with rational coefficients, x is a rational number. Conversely, let x be a rational number, and $x = a/c$ its reduced fractional expression. Then we can take integers b, d so that $ad - bc = 1$. Put $\gamma = \begin{bmatrix} a & b \\ c & d \end{bmatrix}$, then $\gamma \in \Gamma$ and $\gamma \infty = x$. Therefore x is Γ -equivalent to ∞ . This proves (2). (3): Let g be the genus of \mathfrak{R}_Γ . By Theorem 2.4.3, Theorem 4.1.2(2) and above (1) and (2), we have

$$1/6 = 2g - 2 + (1 - 1/2) + (1 - 1/3) + 1,$$

so that $g = 0$. □

We can calculate the dimensions of $\mathcal{G}_k(\Gamma)$ and $\mathcal{S}_k(\Gamma)$ using Theorem 2.5.2 and Theorem 4.1.3.

Corollary 4.1.4. *For an even integer $k \geq 2$, we have*

$$\dim \mathcal{S}_k(\Gamma) = \begin{cases} 0 & \text{if } k = 2, \\ [k/12] - 1 & \text{if } k \equiv 2 \pmod{12}, \quad k > 2, \\ [k/12] & \text{if } k \not\equiv 2 \pmod{12}, \end{cases}$$

$$\dim \mathcal{G}_k(\Gamma) = \begin{cases} [k/12] & \text{if } k \equiv 2 \pmod{12}, \\ [k/12] + 1 & \text{if } k \not\equiv 2 \pmod{12}. \end{cases}$$

Here $[x]$ denotes the largest integer $\leq x$.

We are going to construct elements of $\mathcal{G}_k(\Gamma)$. For an even integer $k \geq 4$, we put

$$(4.1.3) \quad E_k(z) = \sum_{\substack{m, n = -\infty \\ (m, n) \neq (0, 0)}}^{\infty} (mz + n)^{-k} \quad (z \in \mathbf{H}).$$

We will prove below that $E_k(z)$ is convergent absolutely and uniformly on any compact subset of \mathbf{H} , and is an automorphic form of weight k with respect to Γ .

Lemma 4.1.5. *The correspondence “ $\begin{bmatrix} a & b \\ c & d \end{bmatrix} \mapsto (c, d)$ ” gives a bijection between $\Gamma_\infty \backslash \Gamma$ and the set*

$$\{(c, d) \in \mathbb{Z} \times \mathbb{Z} \mid (c, d) = 1\} / \{\pm 1\}.$$

Proof. The surjectivity is obvious, while the injectivity is proved by (2.1.4). □

Using the Poincaré series in §2.6, we put for an even integer $k \geq 4$,

$$(4.1.4) \quad G_k(z) = F_k(z; \phi_0, \chi_0, \Gamma_\infty, \Gamma),$$

where $\phi_0 = 1$ and χ_0 is the trivial character of Γ . Then by Lemma 4.1.5,

$$(4.1.5) \quad G_k(z) = \frac{1}{2} \sum_{\substack{m, n \in \mathbb{Z} \\ (m, n) = 1}} (mz + n)^{-k}, \quad z \in \mathbf{H},$$

and

$$(4.1.6) \quad E_k(z) = 2\zeta(k)G_k(z),$$

where $\zeta(s)$ is the Riemann zeta-function.

Lemma 4.1.6. *Let k be an even integer ≥ 4 .*

(1) $E_k(z)$ is convergent absolutely and uniformly on any compact subset of \mathbf{H} , and belongs to $\mathcal{G}_k(\Gamma)$.

(2) $E_k(z)$ has the following Fourier expansion at ∞ :

$$E_k(z) = 2\zeta(k) + 2 \frac{(2\pi i)^k}{(k-1)!} \sum_{n=1}^{\infty} \sigma_{k-1}(n) e^{2\pi i n z},$$

where

$$\sigma_{k-1}(n) = \sum_{0 < d|n} d^{k-1}.$$

Proof. Though the first assertion follows from (4.1.4) and the convergence of the Poincaré series, we here give a direct proof. Let z be any point of \mathbf{H} , and put $L = \{cz + d | c, d \in \mathbb{Z}\}$. For a positive integer n , let M_n be the boundary of the parallelogram with the vertices $\pm nz \pm n$, and $r(z)$ be the distance from the origin 0 to the set M_1 . Then $r(z)$ is a continuous function of z . Since $|L \cap M_n| = 8n$, we see

$$(4.1.7) \quad \sum_{\substack{m, n = -\infty \\ (m, n) \neq (0, 0)}}^{\infty} |mz + n|^{-k} = \sum_{n=1}^{\infty} \sum_{\omega \in L \cap M_n} |\omega|^{-k} \leq 8\zeta(k-1)r(z)^{-k},$$

so that $E_k(z)$ is convergent absolutely and uniformly on any compact subset of \mathbf{H} .

Let $\gamma = \begin{bmatrix} a & b \\ c & d \end{bmatrix} \in \Gamma$, then

$$(4.1.8) \quad m(\gamma z) + n = \{(am + cn)z + (bm + dn)\}(cz + d)^{-1}.$$

When the pair (m, n) runs over all $\mathbb{Z} \times \mathbb{Z} - \{(0, 0)\}$, so does the pair $(am + cn, bm + dn)$. This proves the automorphy of $E_k(z)$. Next let us show (2) and the holomorphy of $E_k(z)$ at ∞ . Now we can rewrite (3.2.20) into

$$(4.1.9) \quad \pi \cot(\pi z) = z^{-1} + \sum_{n=1}^{\infty} \{(z+n)^{-1} + (z-n)^{-1}\}.$$

Moreover, by (3.2.19) we have

$$(4.1.10) \quad \pi \cot(\pi z) = \pi i \left(1 - 2 \sum_{n=0}^{\infty} e^{2\pi i n z} \right).$$

Differentiating (4.1.9) and (4.1.10) $k-1$ times, we get

$$(4.1.11) \quad \begin{aligned} & (-1)^k (k-1)! \left\{ z^{-k} + \sum_{n=1}^{\infty} ((z+n)^{-k} + (z-n)^{-k}) \right\} \\ &= (2\pi i)^k \sum_{n=1}^{\infty} n^{k-1} e^{2\pi i n z}. \end{aligned}$$

Since $\sum_{n=-\infty}^{\infty} (z+n)^{-k}$ is absolutely convergent, we can exchange the order of summation on the left-hand side and rewrite it as

$$(4.1.12) \quad (-1)^k(k-1)! \sum_{n=-\infty}^{\infty} (z+n)^{-k} = (2\pi i)^k \sum_{n=1}^{\infty} n^{k-1} e^{2\pi i n z}.$$

Therefore we obtain

$$\begin{aligned} E_k(z) &= 2 \sum_{n=1}^{\infty} n^{-k} + 2 \sum_{m=1}^{\infty} \sum_{n=-\infty}^{\infty} (mz+n)^{-k} \\ &= 2\zeta(k) + \frac{2(2\pi i)^k}{(k-1)!} \sum_{m=1}^{\infty} \sum_{n=1}^{\infty} n^{k-1} e^{2\pi i m n z}. \end{aligned}$$

This proves (2). □

It follows from Corollary 4.1.4 and (4.1.6) that

$$(4.1.13) \quad \mathcal{N}_k(\Gamma) = \mathbb{C} \cdot E_k(z) \quad (k: \text{even}, \geq 4).$$

Furthermore, for the study of $\mathcal{G}_k(\Gamma)$, it is useful to define

$$(4.1.14) \quad \Delta(z) = 12^{-3}(G_4(z)^3 - G_6(z)^2),$$

$$(4.1.15) \quad J(z) = G_4(z)^3/\Delta(z).$$

It is obvious that $\Delta(z) \in \mathcal{S}_{12}(\Gamma)$ and $J(z) \in \mathcal{A}_0(\Gamma)$. We note that in relation to elliptic functions and elliptic curves, it is more useful to consider the functions

$$(4.1.16) \quad g_2(z) = 60E_4(z), \quad g_3(z) = 140E_6(z).$$

Then

$$(4.1.17) \quad (2\pi)^{12} \Delta(z) = g_2(z)^3 - 27g_3(z)^2,$$

$$(4.1.18) \quad (2\pi)^{12} J(z) = 12^3 g_2(z)^3 / \Delta(z).$$

Theorem 4.1.7. (1) $\Delta(z)$ belongs to $\mathcal{S}_{12}(\Gamma)$. Let $\Delta(z) = \sum_{n=1}^{\infty} \tau_n e^{2\pi i n z}$ be the Fourier expansion, then $\tau_n \in \mathbb{Z}$ and $\tau_1 = 1$.

(2) $\Delta(z)$ has no zeros on \mathbf{H} .

(3) $\mathcal{A}_0(\Gamma) = \mathbb{C}(J)$ and $J(z)$ has the following Fourier expansion at ∞ :

$$J(z) = e^{-2\pi i z} + \sum_{n=0}^{\infty} c_n e^{2\pi i n z}, \quad c_n \in \mathbb{Z}.$$

Proof. (1): We have only to study the Fourier expansion of $\Delta(z)$ at ∞ . For even integers $k \geq 2$,

$$\zeta(k) = \frac{-(2\pi i)^k}{2k!} B_k$$

by Theorem 3.2.3. Since $B_4 = -1/30$ and $B_6 = 1/42$, we have

$$(4.1.19) \quad G_4(z) = 1 + 240e^{2\pi i z} + \cdots,$$

$$(4.1.20) \quad G_6(z) = 1 - 504e^{2\pi i z} + \cdots.$$

Therefore, putting $\Delta(z) = \sum_{n=0}^{\infty} \tau_n e^{2\pi inz}$, we get

$$12^3 \tau_0 = 1 - 1 = 0,$$

$$12^3 \tau_1 = 3 \cdot 240 + 2 \cdot 504 = 1728 = 12^3.$$

Thus $\Delta \in \mathcal{S}_{12}(\Gamma)$ and $\tau_1 = 1$. We postpone the proofs of the integrality of τ_n and (2) until Theorem 4.4.2. (3): The Fourier expansion of $J(z)$ at ∞ follows from (1) and (4.1.20). By (2), $J(z)$ has, as a function on \mathfrak{R}_Γ , a pole of order 1 at the cusp. Since $K(\mathfrak{R}_\Gamma)$ is isomorphic to $\mathcal{A}_0(\Gamma)$ by the canonical correspondence, we obtain $[\mathcal{A}_0(\Gamma):\mathbb{C}(J)] = n_\infty(J) = 1$ by (1.8.6). \square

Theorem 4.1.8. *Let $k \geq 4$ be an even integer. Then $\mathcal{G}_k(\Gamma)$ has a basis*

$$\{G_4(z)^m G_6(z)^n \mid 4m + 6n = k, \quad m, n \geq 0\}.$$

Proof. It is obvious that if $4m + 6n = k$, and $m, n \geq 0$, then $G_4(z)^m G_6(z)^n \in \mathcal{G}_k(\Gamma)$. An easy calculation shows

$$\begin{aligned} (4.1.21) \quad & \# \{(m, n) \mid 4m + 6n = k, \quad m, n \geq 0\} \\ &= \begin{cases} [k/12] & \text{if } k \equiv 2 \pmod{12}, \\ [k/12] + 1 & \text{if } k \not\equiv 2 \pmod{12}, \end{cases} \\ &= \dim \mathcal{G}_k(\Gamma). \end{aligned}$$

Thus we have only to prove that $G_4(z)^m G_6(z)^n$ ($4m + 6n = k$, $m, n \geq 0$) are linearly independent. Suppose they are not so, and let

$$(4.1.22) \quad \sum_{4m+6n=k} c_{m,n} G_4^m G_6^n = 0 \quad (c_{m,n} \in \mathbb{C})$$

be a non-trivial linear relation. We define a polynomial of two variables X, Y by

$$(4.1.23) \quad F(X, Y) = \sum_{4m+6n=k} c_{m,n} X^m Y^n.$$

By assumption, $F(G_4, G_6) = 0$. Take two complex numbers b_4, b_6 so that $F(b_4, b_6) \neq 0$ and $b_4^3 - b_6^2 \neq 0$. Since for any complex number a , $J(z) - a$ has a zero by (1.8.6), there exists a point z_0 of \mathbf{H} such that

$$(4.1.24) \quad J(z_0) = \frac{12^3 b_4^3}{b_4^3 - b_6^2}.$$

Now we are going to show the existence of a complex number c satisfying

$$c^2 b_4 = G_4(z_0), \quad c^3 b_6 = G_6(z_0).$$

First assume $b_4 = 0$. Then $b_6 \neq 0$, hence we can take a complex number c so that $c^3 b_6 = G_6(z_0)$. On the other hand, $G_4(z_0) = 0$ by (4.1.24) and $\Delta(z_0) \neq 0$. This implies $c^2 b_4 = G_4(z_0)$. Next suppose $b_4 \neq 0$. Take a complex number c so that $c^2 b_4 = G_4(z_0)$. Then we get $c^3 b_6 = \pm G_6(z_0)$ by (4.1.24). Replacing c with $-c$, if necessary, we obtain $c^3 b_6 = G_6(z_0)$. Now, since $\Delta(z_0) = 12^{-3} c^6 (b_4^3 - b_6^2) \neq 0$, we

get $c \neq 0$, so that

$$F(G_4(z_0), G_6(z_0)) = c^{k/2} F(b_4, b_6) \neq 0;$$

this is a contradiction. □

We conclude this section with a remark on $E_k(z)$. We have

$$(4.1.25) \quad cE_k(z) = -\frac{B_k}{2k} + \sum_{n=1}^{\infty} \sigma_{k-1}(n)e^{2\pi inz}, \quad c = (k-1)!/2(2\pi i)^k.$$

Using the Fourier coefficients of (4.1.25), we put

$$(4.1.26) \quad L_k(s) = \sum_{n=1}^{\infty} \sigma_{k-1}(n)n^{-s}.$$

Then we see easily that it is a product of two Riemann zeta-functions

$$(4.1.27) \quad L_k(s) = \zeta(s)\zeta(s-k+1),$$

and therefore, $L_k(s)$ is convergent on $\text{Re}(s) > k$, and has an Euler product

$$L_k(s) = \prod_p [(1-p^{-s})(1-p^{k-1-s})]^{-1}.$$

The analytical continuity and the functional equation of $\zeta(s)$ induce those of $L_k(s)$.

§4.2. Congruence Modular Groups

For a positive integer N , we define subgroups $\Gamma_0(N)$, $\Gamma_1(N)$ and $\Gamma(N)$ of $SL_2(\mathbb{Z})$ by

$$\begin{aligned} \Gamma_0(N) &= \left\{ \begin{bmatrix} a & b \\ c & d \end{bmatrix} \in SL_2(\mathbb{Z}) \mid c \equiv 0 \pmod{N} \right\}, \\ \Gamma_1(N) &= \left\{ \begin{bmatrix} a & b \\ c & d \end{bmatrix} \in SL_2(\mathbb{Z}) \mid c \equiv 0, \quad a \equiv d \equiv 1 \pmod{N} \right\}, \\ \Gamma(N) &= \left\{ \begin{bmatrix} a & b \\ c & d \end{bmatrix} \in SL_2(\mathbb{Z}) \mid b \equiv c \equiv 0, \quad a \equiv d \equiv 1 \pmod{N} \right\}. \end{aligned}$$

We note

$$SL_2(\mathbb{Z}) = \Gamma_0(1) = \Gamma_1(1) = \Gamma(1),$$

and

$$SL_2(\mathbb{Z}) \supset \Gamma_0(N) \supset \Gamma_1(N) \supset \Gamma(N).$$

Further if $M|N$, then

$$\Gamma_0(M) \supset \Gamma_0(N), \quad \Gamma_1(M) \supset \Gamma_1(N), \quad \Gamma(M) \supset \Gamma(N).$$

These subgroups are modular groups since $[\Gamma(1):\Gamma(N)] < \infty$, which will be proved below. We call $\Gamma(N)$ a *principal congruence modular group*, and $\Gamma_0(N)$ and

$\Gamma_1(N)$ modular groups of Hecke type. We call N the level of $\Gamma_0(N)$, $\Gamma_1(N)$, and $\Gamma(N)$. A modular group containing a principal congruence modular group is called a congruence modular group. For an element $\gamma = \begin{bmatrix} a & b \\ c & d \end{bmatrix} \in M_2(\mathbb{Z})$, we define an element $\lambda_N(\gamma)$ or $\gamma \bmod N$ of $M_2(\mathbb{Z}/N\mathbb{Z})$ by

$$\lambda_N(\gamma) = \gamma \bmod N = \begin{bmatrix} \bar{a} & \bar{b} \\ \bar{c} & \bar{d} \end{bmatrix},$$

where $\bar{a} = a \bmod N$, $\bar{b} = b \bmod N$, $\bar{c} = c \bmod N$, $\bar{d} = d \bmod N$. Then λ_N induces a homomorphism of $SL_2(\mathbb{Z})$ into $SL_2(\mathbb{Z}/N\mathbb{Z})$. We note that for integers m, n ,

(4.2.1) if $(m, n, N) = 1$, then there exist integers m', n' such that

$$m' \equiv m \bmod N, \quad n' \equiv n \bmod N \quad \text{and} \quad (m', n') = 1.$$

This can be easily shown, for example, by the Dirichlet theorem on arithmetic progression.

Theorem 4.2.1. Let λ_N be the homomorphism of $SL_2(\mathbb{Z})$ into $SL_2(\mathbb{Z}/N\mathbb{Z})$ defined above.

(1) λ_N is surjective.

(2) $\text{Ker}(\lambda_N) = \Gamma(N)$; in particular, $\Gamma(N)$ is a normal subgroup of $\Gamma(1)$.

Proof. (2) is obvious. Let us show (1). Let $\begin{bmatrix} \bar{a} & \bar{b} \\ \bar{c} & \bar{d} \end{bmatrix}$ be an element of $SL_2(\mathbb{Z}/N\mathbb{Z})$, and take integers a_1, b_1, c_1, d_1 so that

$$\begin{bmatrix} a_1 & b_1 \\ c_1 & d_1 \end{bmatrix} \bmod N = \begin{bmatrix} \bar{a} & \bar{b} \\ \bar{c} & \bar{d} \end{bmatrix}.$$

Then $a_1 d_1 - b_1 c_1 \equiv 1 \bmod N$, so that $(c_1, d_1, N) = 1$. By (4.2.1), we may assume $(c_1, d_1) = 1$. Let n be an integer such that

$$a_1 d_1 - b_1 c_1 = 1 + nN.$$

Since $(c_1, d_1) = 1$, we can take integers a_2, b_2 so that $a_2 d_1 - b_2 c_1 = -n$. Putting

$$\begin{aligned} a &= a_1 + a_2 N, & b &= b_1 + b_2 N, \\ c &= c_1, & d &= d_1, \end{aligned}$$

we see $\begin{bmatrix} a & b \\ c & d \end{bmatrix} \in SL_2(\mathbb{Z})$, and $\begin{bmatrix} a & b \\ c & d \end{bmatrix} \bmod N = \begin{bmatrix} \bar{a} & \bar{b} \\ \bar{c} & \bar{d} \end{bmatrix}$. □

Corollary 4.2.2. *The mapping “ $\begin{bmatrix} a & b \\ c & d \end{bmatrix} \mapsto d \bmod N \in (\mathbb{Z}/N\mathbb{Z})^\times$ ” induces an isomorphism*

$$\Gamma_0(N)/\Gamma_1(N) \simeq (\mathbb{Z}/N\mathbb{Z})^\times.$$

Proof. For two elements $\gamma = \begin{bmatrix} * & * \\ c & d \end{bmatrix}$, and $\gamma' = \begin{bmatrix} * & b' \\ * & d' \end{bmatrix}$ of $\Gamma_0(N)$, we see that

$$\gamma\gamma' = \begin{bmatrix} * & * \\ * & cb' + dd' \end{bmatrix},$$

and

$$cb' + dd' \equiv dd' \pmod{N}.$$

Therefore the mapping is a homomorphism. The latter part is straightforward from Theorem 4.2.1. \square

We note that we can take a complete set of representatives of $\Gamma_0(N)/\Gamma_1(N)$ consisting of the elements γ of the form

$$\gamma \bmod N = \begin{bmatrix} * & 0 \\ 0 & * \end{bmatrix}.$$

Now let $N = \prod_p p^e$ be the expression as a product of prime numbers. Then $\mathbb{Z}/N\mathbb{Z}$ is isomorphic to $\prod_p (\mathbb{Z}/p^e\mathbb{Z})$ by the correspondence “ $a \mapsto \prod_p (a \bmod p^e)$ ”, so that

$$M_2(\mathbb{Z}/N\mathbb{Z}) \simeq \prod_p M_2(\mathbb{Z}/p^e\mathbb{Z})$$

through the correspondence:

$$\begin{bmatrix} a & b \\ c & d \end{bmatrix} \mapsto \prod_p \left(\begin{bmatrix} a & b \\ c & d \end{bmatrix} \bmod p^e \right).$$

It is obvious that if $\begin{bmatrix} a & b \\ c & d \end{bmatrix} \in SL_2(\mathbb{Z})$, then $\begin{bmatrix} a & b \\ c & d \end{bmatrix} \bmod p^e \in SL_2(\mathbb{Z}/p^e\mathbb{Z})$. Conversely, suppose $\begin{bmatrix} a & b \\ c & d \end{bmatrix} \bmod p^e \in SL_2(\mathbb{Z}/p^e\mathbb{Z})$ for all prime factors p of N . Then $ad - bc \equiv 1 \pmod{p^e}$, so that $ad - bc \equiv 1 \pmod{N}$. Therefore we get the following

Lemma 4.2.3. *Let N be a positive integer, and $N = \prod_p p^e$ the expression as a product of prime numbers. Then*

$$SL_2(\mathbb{Z}/N\mathbb{Z}) \simeq \prod_p SL_2(\mathbb{Z}/p^e\mathbb{Z}).$$

Theorem 4.2.4. *For a positive integer N , we have:*

- (1) $|GL_2(\mathbb{Z}/N\mathbb{Z})| = \phi(N)|SL_2(\mathbb{Z}/N\mathbb{Z})|;$
- (2) $|SL_2(\mathbb{Z}/N\mathbb{Z})| = N^3 \prod_{p|N} (1 - 1/p^2).$

Here ϕ is the Euler function.

Proof. The first assertion is obvious. We have only to verify (2) for a prime power $N = p^e$ by Lemma 4.2.3. First suppose $e = 1$. Then $\mathbb{Z}/p\mathbb{Z}$ is a field, so that $|GL_2(\mathbb{Z}/p\mathbb{Z})|$ is equal to the number of all ordered basis of the two dimensional vector space $\mathbb{Z}/p\mathbb{Z} \oplus \mathbb{Z}/p\mathbb{Z}$ over $\mathbb{Z}/p\mathbb{Z}$. Then it is given by $p(p-1)(p^2-1)$, thus, (1) implies

$$|SL_2(\mathbb{Z}/p\mathbb{Z})| = p(p^2 - 1) = p^3(1 - 1/p^2).$$

Next assume $e > 1$. Let

$$\lambda': SL_2(\mathbb{Z}/p^e\mathbb{Z}) \rightarrow SL_2(\mathbb{Z}/p\mathbb{Z})$$

be the canonical homomorphism. Then λ' is surjective by Theorem 4.2.1(1) and

$$\text{Ker}(\lambda') = \left\{ \begin{bmatrix} a & b \\ c & d \end{bmatrix} \in SL_2(\mathbb{Z}/p^e\mathbb{Z}) \mid \begin{bmatrix} a & b \\ c & d \end{bmatrix} \equiv \begin{bmatrix} 1 & 0 \\ 0 & 1 \end{bmatrix} \pmod{p} \right\}.$$

For any elements b, c, d of $\mathbb{Z}/p^e\mathbb{Z}$ such that $b \equiv c \equiv 0 \pmod{p}$, $d \equiv 1 \pmod{p}$, there exists a unique element a of $\mathbb{Z}/p^e\mathbb{Z}$ such that $ad - bc = 1$. Therefore $|\text{Ker}(\lambda')| = p^{3(e-1)}$, and

$$|SL_2(\mathbb{Z}/p^e\mathbb{Z})| = p^{3e}(1 - 1/p^2). \quad \square$$

For a modular group Γ , we write

$$\bar{\Gamma} = \iota(\Gamma) \subset \text{Aut}(\mathbf{H}),$$

where ι is the homomorphism of $SL_2(\mathbb{Z})$ onto $\text{Aut}(\mathbf{H})$ defined in §1.1. Then $\bar{\Gamma} \simeq \Gamma/Z(\Gamma)$. We also write, for the stabilizers Γ_z ($z \in \mathbf{H} \cup \mathbb{R} \cup \{\infty\}$),

$$\bar{\Gamma}_z = \iota(\Gamma_z) \quad (\simeq \Gamma_z/Z(\Gamma)).$$

Theorem 4.2.5. *For an integer $N \geq 2$, we have:*

$$(1) \quad [\bar{\Gamma}(1):\bar{\Gamma}(N)] = \begin{cases} \frac{1}{2}[\Gamma(1):\Gamma(N)] = \frac{1}{2}N^3 \prod_{p|N} (1 - 1/p^2) & (N > 2), \\ [\Gamma(1):\Gamma(2)] = 6 & (N = 2). \end{cases}$$

$$(2) \quad [\bar{\Gamma}(1):\bar{\Gamma}_0(N)] = [\Gamma(1):\Gamma_0(N)] = N \prod_{p|N} (1 + 1/p).$$

$$(3) \quad [\bar{\Gamma}_0(N):\bar{\Gamma}_1(N)] = \begin{cases} \frac{1}{2}[\Gamma_0(N):\Gamma_1(N)] = \phi(N)/2 & (N > 2), \\ [\Gamma_0(2):\Gamma_1(2)] = 1 & (N = 2). \end{cases}$$

Here ϕ is the Euler function.

Proof. Since $\Gamma(2) \ni -1$ and $\Gamma(N) \not\ni -1$ for $N > 2$, we see

$$[\bar{\Gamma}(1):\bar{\Gamma}(N)] = \begin{cases} \frac{1}{2}[\Gamma(1):\Gamma(N)] & (N > 2), \\ [\Gamma(1):\Gamma(2)] & (N = 2). \end{cases}$$

Thus we obtain (1) by Theorem 4.2.1 and Theorem 4.2.4. Since $\text{Ker}(\lambda_N) = \Gamma(N) \subset \Gamma_1(N)$, we see that

$$[\Gamma(1):\Gamma_0(N)] = [SL_2(\mathbb{Z}/N\mathbb{Z}):\lambda_N(\Gamma_0(N))]$$

and

$$[\Gamma_0(N):\Gamma_1(N)] = [\lambda_N(\Gamma_0(N)):\lambda_N(\Gamma_1(N))].$$

Furthermore

$$\lambda_N(\Gamma_0(N)) = \left\{ \begin{bmatrix} a & b \\ 0 & a^{-1} \end{bmatrix} \in SL_2(\mathbb{Z}/N\mathbb{Z}) \mid a \in (\mathbb{Z}/N\mathbb{Z})^\times, b \in \mathbb{Z}/N\mathbb{Z} \right\},$$

and

$$\lambda_N(\Gamma_1(N)) = \left\{ \begin{bmatrix} 1 & b \\ 0 & 1 \end{bmatrix} \in SL_2(\mathbb{Z}/N\mathbb{Z}) \mid b \in \mathbb{Z}/N\mathbb{Z} \right\}.$$

Therefore $|\lambda_N(\Gamma_0(N))| = N\phi(N)$ and $|\lambda_N(\Gamma_1(N))| = N$. Noting that $-1 \in \Gamma_0(N)$, $-1 \in \Gamma_1(2)$ and $-1 \notin \Gamma_1(N)$ for $N > 2$, we obtain (2) and (3). \square

Lemma 4.2.6. *If Γ is a modular group, then any elliptic element of Γ is of order 2 or 3.*

Proof. Though the assertion is obvious from Theorem 4.1.3, we give here an algebraic proof. We may assume $\Gamma \ni -1$ by taking $\Gamma \cdot \{\pm 1\}$ in place of Γ . Let $\gamma = \begin{bmatrix} a & b \\ c & d \end{bmatrix}$ be an elliptic element of Γ , and z a point of \mathbf{H} such that $\gamma z = z$. By definition, we see $|a + d| < 2$, so that the characteristic polynomial of γ is $X^2 + 1$ or $X^2 \pm X + 1$. Hence $\gamma^4 = 1$ or $\gamma^6 = 1$. Since the stabilizer Γ_z is cyclic by Theorem 1.5.4, and $\Gamma_z \ni -1$, Γ_z is a cyclic group of order 2 or 3. \square

We are going to study elliptic points and cusps of modular groups. For a modular group Γ , we denote by $v_2(\Gamma)$ (resp. $v_3(\Gamma)$) the number of inequivalent elliptic points of Γ of order 2 (resp. 3), and by $v_\infty(\Gamma)$ the number of inequivalent cusps of Γ . Let P_Γ be the set of the cusps of Γ . By Corollary 1.5.5 and Theorem 4.1.3, we see

$$P_\Gamma = P_{\Gamma(1)} = \mathbb{Q} \cup \{\infty\}.$$

Since all points of $\mathbb{Q} \cup \{\infty\}$ are $\Gamma(1)$ -equivalent,

(4.2.2) *the correspondence “ $\Gamma(1) \ni \alpha \mapsto \alpha \in P_\Gamma$ ” induces a bijection of $\Gamma \backslash \Gamma(1) / \Gamma(1)_\infty$ onto $\Gamma \backslash P_\Gamma$.*

In particular,

$$(4.2.3) \quad |\Gamma \backslash P_\Gamma| = |\Gamma \backslash \Gamma(1) / \Gamma(1)_\infty|.$$

Next we assume $-1 \notin \Gamma$. To distinguish regular and irregular cusps of Γ , we put

$$(4.2.4) \quad \Gamma(1)_\infty^+ = \left\{ \begin{bmatrix} 1 & n \\ 0 & 1 \end{bmatrix} \mid n \in \mathbb{Z} \right\} \subset \Gamma(1)_\infty,$$

and define a mapping

$$(4.2.5) \quad \begin{array}{ccc} \eta: \Gamma \backslash \Gamma(1) / \Gamma(1)_\infty^+ & \longrightarrow & \Gamma \backslash \Gamma(1) / \Gamma(1)_\infty \\ \bigcup & & \bigcup \\ \Gamma \alpha \Gamma(1)_\infty^+ & \longmapsto & \Gamma \alpha \Gamma(1)_\infty. \end{array}$$

Since $[\Gamma(1)_\infty : \Gamma(1)_\infty^+] = 2$, the number of the inverse image by η of each element of $\Gamma \backslash \Gamma(1) / \Gamma(1)_\infty$ is 1 or 2. Let γ be an element of $\Gamma(1)$, then we see that

$$(4.2.6) \quad \begin{aligned} |\eta^{-1}(\Gamma \gamma \Gamma(1)_\infty)| = 1 &\Leftrightarrow \Gamma \gamma \Gamma(1)_\infty = \Gamma \gamma \Gamma(1)_\infty^+ \\ &\Leftrightarrow (\gamma^{-1} \Gamma \gamma) \Gamma(1)_\infty^+ \supset \Gamma(1)_\infty \\ &\Leftrightarrow \gamma^{-1} \Gamma \gamma \ni \begin{bmatrix} -1 & h \\ 0 & -1 \end{bmatrix} \text{ with } h > 0 \\ &\Leftrightarrow \gamma \infty \text{ is an irregular cusp.} \end{aligned}$$

Now we shall calculate $v_2(\Gamma)$ and $v_3(\Gamma)$ for $\Gamma = \Gamma_0(N)$, $\Gamma_1(N)$ and $\Gamma(N)$.

Theorem 4.2.7. *For $N \geq 2$, we have:*

$$\begin{aligned} v_2(\Gamma_0(N)) &= \begin{cases} 0 & \text{if } 4|N, \\ \prod_{p|N} \left(1 + \left(\frac{-1}{p}\right)\right) & \text{if } 4 \nmid N, \end{cases} \\ v_3(\Gamma_0(N)) &= \begin{cases} 0 & \text{if } 9|N, \\ \prod_{p|N} \left(1 + \left(\frac{-3}{p}\right)\right) & \text{if } 9 \nmid N, \end{cases} \\ v_\infty(\Gamma_0(N)) &= \sum_{0 < d|N} \phi((d, N/d)) \\ &= \prod_{p|N} \left\{ \sum_{f=0}^e \phi(p^{\min(f, e-f)}) \right\} \quad \left(N = \prod_p p^e \right). \end{aligned}$$

Here ϕ is the Euler function; $(-)$ denotes the quadratic residue symbol (see §3.1).

Proof. Put $v_i = v_i(\Gamma_0(N))$ for $i = 2, 3$ and ∞ . First we calculate v_3 . Let z_0 be an elliptic point of $\Gamma_0(N)$ of order 3. Since $-1 \in \Gamma_0(N)$, $\Gamma_0(N)_{z_0}$ is a cyclic group of order 6. By Lemma 1.3.5(1), there exist exactly two elements of $\Gamma_0(N)_{z_0}$ of order 6, which are not conjugate. Therefore,

$$v_3 = \frac{1}{2} \# \{ \Gamma_0(N)\text{-conjugacy classes of the elements of order 6 in } \Gamma_0(N) \}.$$

On the other hand, $\begin{bmatrix} -1 & 0 \\ 0 & 1 \end{bmatrix}$ belongs to the normalizer of $\Gamma_0(N)$, and the

conjugate of an elliptic element of $\Gamma_0(N)$ by $\begin{bmatrix} -1 & 0 \\ 0 & 1 \end{bmatrix}$ is also an elliptic element of the same order. Put

$$\Gamma_0^\pm(N) = \Gamma_0(N) \cup \Gamma_0(N) \begin{bmatrix} -1 & 0 \\ 0 & 1 \end{bmatrix},$$

then by Lemma 1.3.5(1),

$$v_3 = \# \{ \Gamma_0^\pm(N)\text{-conjugacy classes of the elements of order 6 in } \Gamma_0(N) \}.$$

Put $\zeta = e^{\pi i/3}$, and let α be an element of $\Gamma_0(N)$ of order 6. Put

$$L = \left\{ \begin{bmatrix} a \\ b \end{bmatrix} \middle| a, b \in \mathbb{Z} \right\} \quad (\simeq \mathbb{Z}^2).$$

We define the action of $\mathbb{Z}[\zeta]$ on L by

$$(a + b\zeta) \begin{bmatrix} u \\ v \end{bmatrix} = a \begin{bmatrix} u \\ v \end{bmatrix} + b\alpha \begin{bmatrix} u \\ v \end{bmatrix}.$$

Then L is a left $\mathbb{Z}[\zeta]$ -module. Since $\alpha \in \Gamma_0(N)$, the subgroup

$$L_0 = \left\{ \begin{bmatrix} a \\ Nb \end{bmatrix} \middle| a, b \in \mathbb{Z} \right\}$$

of L is stable under the action of $\mathbb{Z}[\zeta]$. Since $\mathbb{Z}[\zeta]$ is a principal ideal domain, L is isomorphic to a direct sum of copies of $\mathbb{Z}[\zeta]$. Therefore comparing the ranks of L and $\mathbb{Z}[\zeta]$ over \mathbb{Z} , we see that L is isomorphic to $\mathbb{Z}[\zeta]$ as $\mathbb{Z}[\zeta]$ -modules. We denote this isomorphism by ρ , and put

$$I_\alpha = \rho^{-1}(L_0).$$

Since L_0 is a $\mathbb{Z}[\zeta]$ -submodule of L , I_α is an ideal of $\mathbb{Z}[\zeta]$. Since any $\mathbb{Z}[\zeta]$ -automorphism of $\mathbb{Z}[\zeta]$ is obtained by the multiplication of a unit of $\mathbb{Z}[\zeta]$, I_α is independent of the choice of ρ . Moreover

$$(4.2.7) \quad \mathbb{Z}[\zeta]/I_\alpha \simeq L/L_0 \simeq \mathbb{Z}/N\mathbb{Z}.$$

Let β be an element of $\Gamma_0(N)$ conjugate to α by an element of $\Gamma_0^\pm(N)$. Since L_0 is stable under the left multiplication of any element of $\Gamma_0^\pm(N)$, we get $I_\alpha = I_\beta$. Conversely, if I is an ideal of $\mathbb{Z}[\zeta]$ satisfying

$$(4.2.8) \quad \mathbb{Z}[\zeta]/I \simeq \mathbb{Z}/N\mathbb{Z},$$

then there exists a basis $\{w_1, w_2\}$ of $\mathbb{Z}[\zeta]$ over \mathbb{Z} such that

$$(4.2.9) \quad \{w_1, Nw_2\} \text{ is a basis of } I \text{ over } \mathbb{Z}.$$

Let $\alpha \in M_2(\mathbb{Z})$ be the representation matrix for ζ with respect to the basis $\{w_1, w_2\}$, namely

$$(4.2.10) \quad (\zeta w_1, \zeta w_2) = (w_1, w_2)\alpha.$$

Since the minimal polynomial of ζ over \mathbb{Q} is $X^2 - X + 1$, we see $\det(\alpha) = 1$. Furthermore since I is an ideal of $\mathbb{Z}[\zeta]$ and $\{w_1, Nw_2\}$ is a basis of I , we see

$\alpha \in \Gamma_0(N)$. Next take another basis $\{w'_1, w'_2\}$ of $\mathbb{Z}[\zeta]$ satisfying condition (4.2.9), and let α' be an element of $\Gamma_0(N)$ determined by a basis $\{w'_1, w'_2\}$ as above. Let γ be the element of $M_2(\mathbb{Z})$ such that

$$(w'_1, w'_2) = (w_1, w_2)\gamma.$$

Then by the choice of $\{w_1, w_2\}$ and $\{w'_1, w'_2\}$, we see

$$\gamma \in \Gamma_0^\pm(N),$$

and $\alpha' = \gamma^{-1}\alpha\gamma$. Consequently, the set of $\Gamma_0^\pm(N)$ -conjugacy classes of elements of $\Gamma_0(N)$ of order 6 corresponds bijectively to the set of the ideals I of $\mathbb{Z}[\zeta]$ satisfying (4.2.8). Thus

$$v_3 = \# \{ \text{ideals } I \text{ of } \mathbb{Z}[\zeta] \text{ such that } \mathbb{Z}[\zeta]/I \simeq \mathbb{Z}/N\mathbb{Z} \}.$$

By Theorem 3.1.4,

$$= \begin{cases} 0 & \text{if } 9|N, \\ \prod_{p|N} \left(1 + \left(\frac{-3}{p} \right) \right) & \text{if } 9 \nmid N. \end{cases}$$

A similar calculation is also applicable to v_2 .

We shall calculate v_∞ . Let M_N be the set of all elements of order N in $\mathbb{Z}/N\mathbb{Z} \times \mathbb{Z}/N\mathbb{Z}$. We note that for $(m, n) \in \mathbb{Z} \times \mathbb{Z}$

$$(\bar{m}, \bar{n}) \in M_N \Leftrightarrow (m, n, N) = 1,$$

where $\bar{m} = m \pmod N$, and $\bar{n} = n \pmod N$. By (4.2.1), we see that

$$(4.2.11) \quad \text{the mapping of } \Gamma(1) \text{ into } M_N \text{ defined by } \gamma = \begin{bmatrix} a & b \\ c & d \end{bmatrix} \mapsto (\bar{a}, \bar{c}) \text{ is surjective.}$$

We define an equivalence relation on M_N by

$$\begin{aligned} (\bar{a}, \bar{c}) \sim (\bar{a}', \bar{c}') &\Leftrightarrow (\bar{a}', \bar{c}') = \pm (\bar{m}\bar{a} + \bar{n}\bar{c}, \bar{m}^{-1}\bar{c}) \\ &(\bar{m} \in (\mathbb{Z}/N\mathbb{Z})^\times, \bar{n} \in \mathbb{Z}/N\mathbb{Z}). \end{aligned}$$

Then the mapping in (4.2.11) induces a bijection:

$$\Gamma_0(N) \backslash \Gamma(1) / \Gamma(1)_\infty \rightarrow M_N / \sim.$$

Then $M_N = \prod_p M_{p^e}$ and the equivalence relations on M_N and M_{p^e} are compatible with the product decomposition. In particular, $|M_N / \sim| = \prod_p |M_{p^e} / \sim|$, and therefore, we have only to calculate v_∞ when $N = p^e$. Any element (\bar{a}, \bar{c}) of M_{p^e} is equivalent to an element of the form (\bar{a}', \bar{p}^f) ($0 \leq f \leq e$), and f is uniquely determined. If $f > 0$, then $\bar{a}' \in (\mathbb{Z}/p^e\mathbb{Z})^\times$, and

$$(\bar{a}, \bar{p}^f) \sim (\bar{a}', \bar{p}^f) \Leftrightarrow \bar{a} \equiv \bar{a}' \pmod{p^{\min(f, e-f)}}.$$

If $f = 0$, then all elements of $\{(\bar{a}, \bar{1}) \mid \bar{a} \in \mathbb{Z}/p^e\mathbb{Z}\}$ are equivalent to each other.

Therefore we obtain

$$|M_{p^e}/\sim| = \sum_{f=0}^e \phi(p^{\min(f, e-f)}). \quad \square$$

Next we study elliptic points and cusps of $\Gamma_1(N)$ and $\Gamma(N)$.

Lemma 4.2.8. *Let Γ be a Fuchsian group, and Γ' a normal subgroup of Γ of finite index. For a cusp x of Γ , the number of Γ' -inequivalent cusps which are Γ -equivalent to x is equal to*

$$[\bar{\Gamma}:\bar{\Gamma}']/[\bar{\Gamma}_x:\bar{\Gamma}'_x].$$

Proof. Since $\bar{\Gamma}'$ is a normal subgroup of $\bar{\Gamma}$, $\bar{\Gamma}'\cdot\bar{\Gamma}_x$ is a subgroup of $\bar{\Gamma}$ and the number is given by $|\bar{\Gamma}'\backslash\bar{\Gamma}/\bar{\Gamma}_x| = |\bar{\Gamma}'/\bar{\Gamma}'\cdot\bar{\Gamma}_x|$. Since

$$\begin{aligned} [\bar{\Gamma}:\bar{\Gamma}'] &= [\bar{\Gamma}:\bar{\Gamma}'\cdot\bar{\Gamma}_x][\bar{\Gamma}'\cdot\bar{\Gamma}_x:\bar{\Gamma}'] \\ &= [\bar{\Gamma}:\bar{\Gamma}'\cdot\bar{\Gamma}_x][\bar{\Gamma}_x:\bar{\Gamma}'_x], \end{aligned}$$

we obtain the result. □

Theorem 4.2.9. (1) $\Gamma_1(N)$ ($N \geq 4$) has no elliptic elements.

$$(2) \quad v_\infty(\Gamma_1(N)) = \begin{cases} \frac{1}{2} \sum_{0 < d|N} \phi(d)\phi(N/d) & \text{(all cusps are regular) } (N \geq 5), \\ 3 & \text{(2 regular cusps and 1 irregular cusp) } (N = 4). \end{cases}$$

(We note that $\bar{\Gamma}_1(N) = \bar{\Gamma}_0(N)$ if $N = 2, 3$.)

Proof. (1): Let $\gamma = \begin{bmatrix} a & b \\ c & d \end{bmatrix}$ be an elliptic element of $\Gamma_1(N)$. By definition, $|a+d| < 2$ and $a+d \equiv 2 \pmod N$. So there is no such element if $N \geq 4$.

(2): Let M_N be the set of all elements of order N of $\mathbb{Z}/N\mathbb{Z} \times \mathbb{Z}/N\mathbb{Z}$. Define two equivalence relations \sim and \simeq on M_N by

$$(\bar{a}, \bar{c}) \sim (\bar{a}', \bar{c}') \Leftrightarrow (\bar{a}', \bar{c}') = \pm(\bar{a} + \bar{n}\bar{c}, \bar{c}) \quad (\bar{n} \in \mathbb{Z}/N\mathbb{Z}),$$

$$(\bar{a}, \bar{c}) \simeq (\bar{a}', \bar{c}') \Leftrightarrow (\bar{a}', \bar{c}') = (\bar{a} + \bar{n}\bar{c}, \bar{c}) \quad (\bar{n} \in \mathbb{Z}/N\mathbb{Z}).$$

Then we have the commutative diagram:

$$\begin{array}{ccc} \Gamma_1(N)\backslash\Gamma(1)/\Gamma(1)_\infty^+ & \longrightarrow & M_N/\simeq \\ \eta \downarrow & & \downarrow \xi \\ \Gamma_1(N)\backslash\Gamma(1)/\Gamma(1)_\infty & \longrightarrow & M_N/\sim \end{array}$$

Here the horizontal mappings are the bijections induced by the correspondence

$\Gamma(1) \ni \begin{bmatrix} a & b \\ c & d \end{bmatrix} \mapsto (a \pmod N, c \pmod N) \in M_N$, and the vertical mappings η and ξ

are the natural mappings. First suppose $N \geq 5$. Then ξ is a two fold covering and

$$|M_N/\sim| = \frac{1}{2}|M_N/\simeq|.$$

Then all cusps of $\Gamma_1(N)$ are regular by (4.2.6). By an argument similar to the case of $\Gamma_0(N)$, the calculation of $|M_N/\simeq|$ reduces to the case $N = p^e$. Let $\bar{c} \in \mathbb{Z}/p^e\mathbb{Z}$, and f be the largest integer such that $0 \leq f \leq e$, and $\bar{c} \equiv 0 \pmod{p^f}$. Then

$$(\bar{a}, \bar{c}) \sim (\bar{a}', \bar{c}) \Leftrightarrow \bar{a} \equiv \bar{a}' \pmod{p^f}.$$

Thus, for a fixed \bar{c} , the number of inequivalent (\bar{a}, \bar{c}) is $\phi(p^f)$. Consequently, we obtain

$$|M_{p^e}/\simeq| = \sum_{f=0}^e \phi(p^{e-f})\phi(p^f).$$

Next let $N = 4$. Then the set $\{(\pm 1, 0), (0, \pm 1), (1, 2)\}$ is a complete set of representatives of M_4/\simeq . Since $(1, 0) \sim (-1, 0)$ and $(0, 1) \sim (0, -1)$, we get $|M_4/\simeq| = 3$, and first two classes are regular and the rest is irregular by (4.2.6). □

Theorem 4.2.10. (1) $\Gamma(N)$ ($N \geq 2$) has no elliptic elements.

$$(2) \quad v_\infty(\Gamma(N)) = \begin{cases} \frac{1}{2}N^2 \prod_{p|N} (1 - 1/p^2) & (N \geq 3), \\ 3 & (N = 2). \end{cases}$$

When $N \geq 3$, all cusps are regular.

(3) We can take as a complete set of representatives of inequivalent cusps the set

$$\{m/n \in \mathbb{Q} \cup \{\infty\} \mid (m, n) = 1, (m \pmod N, n \pmod N) \in M_N/\{\pm 1\}\},$$

where M_N is the set of elements of order N in $\mathbb{Z}/N\mathbb{Z} \times \mathbb{Z}/N\mathbb{Z}$.

Proof. (1): Since $\Gamma(N)$ is a normal subgroup of $\Gamma(1)$, any $\Gamma(1)$ -conjugate of an element of $\Gamma(N)$ belongs to $\Gamma(N)$. By Theorem 4.1.3, any elliptic element of $\Gamma(1)$ is conjugate to

$$\pm \begin{bmatrix} 0 & -1 \\ 1 & 0 \end{bmatrix}, \quad \pm \begin{bmatrix} 1 & -1 \\ 1 & 0 \end{bmatrix}, \quad \pm \begin{bmatrix} 0 & -1 \\ 1 & -1 \end{bmatrix},$$

and none of them belongs to $\Gamma(N)$ if $N \geq 2$. Therefore, $\Gamma(N)$ ($N \geq 2$) has no elliptic elements. (2): By Lemma 4.2.8,

$$v_\infty(\Gamma(N)) = [\bar{\Gamma}(1) : \bar{\Gamma}(N)] / [\bar{\Gamma}(1)_\infty : \bar{\Gamma}(N)_\infty].$$

Therefore, the assertion is straightforward from Theorem 4.2.5 and the definition of regular cusps. (3): Connecting the mappings in (4.2.2) and in (4.2.11), we easily obtain a bijection:

$$\Gamma(N) \backslash P_{\Gamma(N)} \rightarrow \Gamma(N) \backslash \Gamma(1) / \Gamma(1)_\infty \rightarrow M_N / \{\pm 1\}.$$

Thus we obtain (3). □

Now the genus of \mathfrak{R}_F for a modular group Γ is given by the following

Theorem 4.2.11. *Let Γ be a modular group, and g the genus of \mathfrak{R}_Γ . Then*

$$g = 1 + \frac{\mu}{12} - \frac{v_2}{4} - \frac{v_3}{3} - \frac{v_\infty}{2},$$

where $v_2 = v_2(\Gamma)$, $v_3 = v_3(\Gamma)$, $v_\infty = v_\infty(\Gamma)$, and $\mu = [\bar{\Gamma}(1) : \bar{\Gamma}]$.

Proof. Since $\mathbf{H}_\Gamma^* = \mathbf{H}_{\Gamma(1)}^*$, there exists a natural mapping

$$F: \mathfrak{R}_\Gamma = \Gamma \backslash \mathbf{H}_\Gamma^* \longrightarrow \mathfrak{R}_{\Gamma(1)} = \Gamma(1) \backslash \mathbf{H}_{\Gamma(1)}^*.$$

We put $\mathbf{H}^* = \mathbf{H}_\Gamma^* = \mathbf{H}_{\Gamma(1)}^*$, and $\mathfrak{R} = \mathfrak{R}_{\Gamma(1)}$. Let $\pi_\Gamma: \mathbf{H}^* \rightarrow \mathfrak{R}_\Gamma$, and $\pi: \mathbf{H}^* \rightarrow \mathfrak{R}$ be the natural mappings. For any point \mathbf{b} of \mathfrak{R}_Γ , take a point $z \in \mathbf{H}^*$ so that $\pi_\Gamma(z) = \mathbf{b}$. Let U_z^* be a neighborhood of z in \mathbf{H}^* given in §1.8. Since $F \circ \pi_\Gamma = \pi$, the following diagram is commutative:

$$(4.2.12) \quad \begin{array}{ccc} & \pi_\Gamma(U_z^*) & \\ \nearrow \pi_\Gamma & & \searrow F \\ U_z^* & \xrightarrow{\pi} & \pi(U_z^*) \end{array}$$

Hence $\{\mathfrak{R}_\Gamma, F\}$ is a covering of \mathfrak{R} of degree μ . Let $e_b = e_{b,F}$ be the ramification index of the covering at \mathbf{b} , and put $F(\mathbf{b}) = \mathbf{a}$. Let $\mathbf{a}_2, \mathbf{a}_3$ and \mathbf{a}_∞ be the elliptic points of order 2 and 3, and the cusp on \mathfrak{R} , respectively. If $\mathbf{a} \neq \mathbf{a}_2, \mathbf{a}_3, \mathbf{a}_\infty$, then \mathbf{b} is an ordinary point, so that π and π_Γ are homeomorphisms on U_z^* , and $e_b = 1$. Suppose $\mathbf{a} = \mathbf{a}_2$, then $e_b = 1$ or 2. We see

$$e_b = 1 \Leftrightarrow F \text{ induces a homeomorphism of } \pi_\Gamma(U_z^*) \text{ on to } \pi(U_z^*) \\ \Leftrightarrow z \text{ is an elliptic point of } \Gamma.$$

Put

$$t = \# \{ \mathbf{b} \in \mathfrak{R}_\Gamma \mid F(\mathbf{b}) = \mathbf{a}_2 \},$$

then $\mu = v_2 + 2(t - v_2)$. Therefore

$$(4.2.13) \quad \Sigma_2(e_b - 1) = \mu - t = (\mu - v_2)/2,$$

where Σ_2 is the summation over the points \mathbf{b} such that $F(\mathbf{b}) = \mathbf{a}_2$. A similar argument implies

$$(4.2.14) \quad \Sigma_3(e_b - 1) = 2(\mu - v_3)/3,$$

where Σ_3 is the summation over the points \mathbf{b} such that $F(\mathbf{b}) = \mathbf{a}_3$. Next assume $F(\mathbf{b}) = \mathbf{a}_\infty$. Then \mathbf{b} is a cusp on \mathfrak{R}_Γ , and

$$v_\infty = \# \{ \mathbf{b} \in \mathfrak{R}_\Gamma \mid F(\mathbf{b}) = \mathbf{a}_\infty \}.$$

Denote by Σ_∞ the summation over the cusps \mathbf{b} such that $F(\mathbf{b}) = \mathbf{a}_\infty$. Then $\Sigma_\infty e_b = \mu$, so that

$$(4.2.15) \quad \Sigma_\infty(e_b - 1) = \mu - v_\infty.$$

Consequently, the formula of the genus follows from (4.2.13), (4.2.14), (4.2.15) and the Hurwitz formula (1.8.8). \square

§4.3. Modular Forms and Dirichlet Series

Automorphic functions and automorphic forms for modular groups are called *modular functions* and *modular forms*, respectively. They are closely connected with number theory.

Let Γ be a congruence modular group. By definition, there exists a positive integer N such that $\Gamma \supset \Gamma(N)$, so that

$$\mathcal{G}_k(\Gamma) \subset \mathcal{G}_k(\Gamma(N)).$$

Therefore the investigation of $\mathcal{G}_k(\Gamma)$ is reduced to that of $\mathcal{G}_k(\Gamma(N))$. Furthermore, we see

$$(4.3.1) \quad \begin{aligned} & \begin{bmatrix} N & 0 \\ 0 & 1 \end{bmatrix}^{-1} \Gamma(N) \begin{bmatrix} N & 0 \\ 0 & 1 \end{bmatrix} \\ &= \left\{ \begin{bmatrix} a & b \\ c & d \end{bmatrix} \in SL_2(\mathbb{Z}) \mid c \equiv 0 \pmod{N^2}, \quad a \equiv d \equiv 1 \pmod{N} \right\} \\ &\supset \Gamma_1(N^2). \end{aligned}$$

Hence, if $f(z) \in \mathcal{G}_k(\Gamma(N))$, then

$$f(Nz) = N^{-k/2} \left(f|_k \begin{bmatrix} N & 0 \\ 0 & 1 \end{bmatrix} \right) (z) \in \mathcal{G}_k(\Gamma_1(N^2)).$$

We note that if $f(z) = \sum_{n=0}^{\infty} a_n e^{2\pi i n z / N}$ is the Fourier expansion at ∞ , then

$$f(Nz) = \sum_{n=0}^{\infty} a_n e^{2\pi i n z}.$$

Therefore the Fourier coefficients of $f(Nz)$ essentially coincide with those of $f(z)$. Consequently, *the study of modular forms with respect to congruence modular groups is reduced to that of $\mathcal{G}_k(\Gamma_1(N))$.*

Let χ be a Dirichlet character mod N . We define a character χ of $\Gamma_0(N)$ by

$$(4.3.2) \quad \chi(\gamma) = \chi(d), \quad \gamma = \begin{bmatrix} a & b \\ c & d \end{bmatrix} \in \Gamma_0(N).$$

Lemma 4.3.1. *For a positive integer N , we have*

$$\mathcal{G}_k(\Gamma_1(N)) = \bigoplus_{\chi} \mathcal{G}_k(\Gamma_0(N), \chi),$$

$$\mathcal{S}_k(\Gamma_1(N)) = \bigoplus_{\chi} \mathcal{S}_k(\Gamma_0(N), \chi),$$

$$\mathcal{N}_k(\Gamma_1(N)) = \bigoplus_{\chi} \mathcal{N}_k(\Gamma_0(N), \chi),$$

where χ runs over all Dirichlet characters mod N .

Proof. Since $\Gamma_1(N)$ is a normal subgroup of $\Gamma_0(N)$, $\Gamma_0(N)$ acts on $\mathcal{G}_k(\Gamma_1(N))$ by “ $f \mapsto f|_k \gamma$ ”, ($\gamma \in \Gamma_0(N)$). This action induces a representation of $\Gamma_0(N)/\Gamma_1(N)$ on $\mathcal{G}_k(\Gamma_1(N))$. Since $\Gamma_0(N)/\Gamma_1(N) \simeq (\mathbb{Z}/N\mathbb{Z})^\times$, all irreducible representations of $\Gamma_0(N)/\Gamma_1(N)$ are induced by Dirichlet characters mod N as above. Therefore we obtain the lemma by decomposing the above representation into irreducible representations. A similar argument is applicable to other cases. \square

By the above lemma, we shall consider exclusively $\mathcal{G}_k(\Gamma_0(N), \chi)$, $\mathcal{S}_k(\Gamma_0(N), \chi)$ and $\mathcal{N}_k(\Gamma_0(N), \chi)$. Hereafter we simply write

$$\begin{aligned} \mathcal{G}_k(N, \chi) &= \mathcal{G}_k(\Gamma_0(N), \chi), \\ \mathcal{S}_k(N, \chi) &= \mathcal{S}_k(\Gamma_0(N), \chi), \\ \mathcal{N}_k(N, \chi) &= \mathcal{N}_k(\Gamma_0(N), \chi). \end{aligned}$$

Let M be a multiple of N . We also express the character mod M induced by a Dirichlet character χ mod N by the same symbol χ . Then

$$\mathcal{G}_k(N, \chi) \subset \mathcal{G}_k(M, \chi), \quad \mathcal{S}_k(N, \chi) \subset \mathcal{S}_k(M, \chi),$$

and by Theorem 2.1.7(2),

$$\mathcal{N}_k(N, \chi) \subset \mathcal{N}_k(M, \chi).$$

For a modular form $f(z) = \sum_{n=0}^{\infty} a_n e^{2\pi i n z} \in \mathcal{G}_k(N, \chi)$, we put

$$(4.3.3) \quad f_\rho(z) = \sum_{n=0}^{\infty} \bar{a}_n e^{2\pi i n z},$$

where \bar{a}_n is the complex conjugate of a_n .

We put, for a positive integer N ,

$$\omega_N = \omega(N) = \begin{bmatrix} 0 & -1 \\ N & 0 \end{bmatrix}.$$

Lemma 4.3.2. *Let χ be a Dirichlet character mod N .*

- (1) *If $\chi(-1) \neq (-1)^k$, then $\mathcal{G}_k(N, \chi) = \{0\}$.*
- (2) *The correspondence “ $f \mapsto f|_k \omega_N$ ” induces the isomorphisms:*

$$\begin{aligned} \mathcal{G}_k(N, \chi) &\simeq \mathcal{G}_k(N, \bar{\chi}), \\ \mathcal{S}_k(N, \chi) &\simeq \mathcal{S}_k(N, \bar{\chi}), \\ \mathcal{N}_k(N, \chi) &\simeq \mathcal{N}_k(N, \bar{\chi}). \end{aligned}$$

- (3) *If $f(z) \in \mathcal{G}_k(N, \chi)$ (resp. $\mathcal{S}_k(N, \chi)$, $\mathcal{N}_k(N, \chi)$), then*

$$f_\rho(z) = \overline{f(-\bar{z})}$$

and it belongs to $\mathcal{G}_k(N, \bar{\chi})$ (resp. $\mathcal{S}_k(N, \bar{\chi})$, $\mathcal{N}_k(N, \bar{\chi})$).

Proof. The first assertion is obvious from (2.1.27). (2): For $f(z) \in \mathcal{G}_k(N, \chi)$, we put

$g = f|_k \omega_N$. For $\gamma = \begin{bmatrix} a & b \\ cN & d \end{bmatrix} \in \Gamma_0(N)$, we have

$$(4.3.4) \quad \omega_N \gamma \omega_N^{-1} = \begin{bmatrix} d & -c \\ -bN & a \end{bmatrix}, \quad \omega_N^2 = -N.$$

Therefore

$$\omega_N \Gamma_0(N) \omega_N^{-1} = \Gamma_0(N),$$

and

$$g|_k \gamma = \chi(a)g = \bar{\chi}(\gamma)g.$$

This implies the automorphy condition. The rest of (2) follows from (2.1.31) and

Theorem 2.8.2. (3): The first part is obvious. For an element $\gamma = \begin{bmatrix} a & b \\ c & d \end{bmatrix} \in SL_2(\mathbb{Z})$,

we put

$$\gamma' = \begin{bmatrix} a & -b \\ -c & d \end{bmatrix}.$$

Then

$$(4.3.5) \quad f_\rho|_k \gamma = (f|_k \gamma')_\rho, \quad \gamma \in SL_2(\mathbb{Z}),$$

by the first part. In particular, if $\gamma \in \Gamma_0(N)$, then $f_\rho|_k \gamma = \bar{\chi}(\gamma)f_\rho$. The conditions at cusps are also verified by (4.3.5). Now for $f(z) \in \mathcal{G}_k(\Gamma_1(N))$ and $g(z) \in \mathcal{S}_k(\Gamma_1(N))$, we see easily

$$(4.3.6) \quad (f_\rho, g) = \overline{(f, g_\rho)}.$$

This implies that if $f(z) \in \mathcal{N}_k(N, \chi)$, then $f_\rho(z) \in \mathcal{N}_k(N, \bar{\chi})$. □

Any element $f(z)$ of $\mathcal{G}_k(N, \chi)$ has a Fourier expansion of the form

$$f(z) = \sum_{n=0}^{\infty} a_n e^{2\pi i n z}.$$

Nevertheless a holomorphic function $f(z)$ on \mathbf{H} with a Fourier expansion is not necessarily a modular form. If $f(z)$ is an Eisenstein series with respect to $\Gamma(1)$, then the Dirichlet series defined in (4.1.26) by using the Fourier coefficients is a product of two Riemann zeta-functions. We analogously define a Dirichlet series $\phi(s)$ using the Fourier coefficients of $f(z)$ by

$$\phi(s) = \sum_{n=1}^{\infty} a_n n^{-s}.$$

If $f(z)$ is a cusp form of weight k , then we have $a_n = O(n^{k/2})$ by Corollary 2.1.6. Hence $\phi(s)$ is convergent absolutely and uniformly on any compact subset of $\text{Re}(s) > k/2 + 1$. In the rest of this section, we shall show an outstanding equivalence obtained by Hecke and Weil between the automorphy of $f(z)$ and certain functional equations satisfied by $\phi(s)$ and its ‘twisted’ Dirichlet series by Dirichlet characters.

Let $f(z)$ be a holomorphic function on \mathbf{H} satisfying the following conditions:

(4.3.7) $f(z)$ has a Fourier expansion

$$f(z) = \sum_{n=0}^{\infty} a_n e^{2\pi i n z},$$

which converges absolutely and uniformly on any compact subset of \mathbf{H} . Further there exists $\nu > 0$ such that

$$f(z) = O(\operatorname{Im}(z)^{-\nu}), \quad (\operatorname{Im}(z) \rightarrow 0)$$

uniformly on $\operatorname{Re}(z)$.

Then by a similar argument as in Corollary 2.1.6, we have

$$(4.3.8) \quad a_n = O(n^\nu).$$

Conversely we obtain

Lemma 4.3.3. For a sequence $\{a_n\}_{n=0}^\infty$ of complex numbers, put

$$f(z) = \sum_{n=0}^\infty a_n e^{2\pi i n z} \quad (z \in \mathbf{H}).$$

If $a_n = O(n^\nu)$ with some $\nu > 0$, then the right-hand side is convergent absolutely and uniformly on any compact subset of \mathbf{H} , and $f(z)$ is holomorphic on \mathbf{H} . Moreover,

$$\begin{aligned} f(z) &= O(\operatorname{Im}(z)^{-\nu-1}) && (\operatorname{Im}(z) \rightarrow 0), \\ f(z) - a_0 &= O(e^{-2\pi \operatorname{Im}(z)}) && (\operatorname{Im}(z) \rightarrow \infty) \end{aligned}$$

uniformly on $\operatorname{Re}(z)$.

Proof. By (3.2.9), we have for $\nu > 0$,

$$\lim_{n \rightarrow \infty} n^\nu / (-1)^n \binom{-\nu-1}{n} = \Gamma(\nu+1).$$

Hence there exists $L > 0$ such that

$$|a_n| \leq L(-1)^n \binom{-\nu-1}{n}$$

for all $n \geq 0$. Put $z = x + iy$, then

$$(4.3.9) \quad \begin{aligned} \sum_{n=0}^\infty |a_n| |e^{2\pi i n z}| &\leq L \left(\sum_{n=0}^\infty (-1)^n \binom{-\nu-1}{n} e^{-2\pi n y} \right) \\ &= L(1 - e^{-2\pi y})^{-\nu-1}. \end{aligned}$$

This implies that $f(z)$ is convergent absolutely and uniformly on any compact subset of \mathbf{H} . Since $(1 - e^{-2\pi y}) = O(y)$ as $y \rightarrow 0$, we see $|f(z)| = O(y^{-\nu-1})$. Moreover (4.3.9) implies that $f(z)$ is bounded when $y \rightarrow \infty$. Put

$$g(z) = \sum_{n=0}^\infty a_{n+1} e^{2\pi i n z}.$$

Since $g(z)$ also satisfies the assumption, it is bounded on a neighborhood of ∞ . Therefore we obtain

$$f(z) - a_0 = e^{2\pi i z} g(z) = O(e^{-2\pi y}) \quad (y \rightarrow \infty). \quad \square$$

By the above lemma, all holomorphic functions $f(z)$ on \mathbf{H} satisfying (4.3.7) correspond bijectively to all sequences $\{a_n\}_{n=0}^{\infty}$ of complex numbers such that $a_n = O(n^\nu)$ with $\nu > 0$.

As a preliminary to Hecke's theorem, we shall prove the following

Lemma 4.3.4. (Phragmen–Lindelöf) For two real numbers ν_1, ν_2 ($\nu_1 < \nu_2$), put

$$F = \{s \in \mathbb{C} \mid \nu_1 \leq \operatorname{Re}(s) \leq \nu_2\}.$$

Let ϕ be a holomorphic function on a domain containing F satisfying

$$|\phi(s)| = O(e^{|\tau|^\delta}) \quad (|\tau| \rightarrow \infty), \quad s = \sigma + i\tau,$$

uniformly on F with $\delta > 0$. For a real number b , if

$$|\phi(s)| = O(|\tau|^b) \quad (|\tau| \rightarrow \infty) \quad \text{on } \operatorname{Re}(s) = \nu_1 \text{ and } \operatorname{Re}(s) = \nu_2,$$

then

$$|\phi(s)| = O(|\tau|^b) \quad (|\tau| \rightarrow \infty) \quad \text{uniformly on } F.$$

Proof. By assumption, there exists $L > 0$ such that $|\phi(s)| \leq Le^{|\tau|^\delta}$. First we consider the case when $b = 0$. Then there exists $M > 0$ such that $|\phi(s)| \leq M$ on the lines $\operatorname{Re}(s) = \nu_1$ and $\operatorname{Re}(s) = \nu_2$. Let m be a positive integer such that $m \equiv 2 \pmod{4}$. Put $s = \sigma + i\tau$. Since $\operatorname{Re}(s^m) = \operatorname{Re}((\sigma + i\tau)^m)$ is a polynomial of σ and τ , and the highest term of τ is $-\tau^m$, we have

$$(4.3.10) \quad \operatorname{Re}(s^m) = -\tau^m + O(|\tau|^{m-1}) \quad (|\tau| \rightarrow \infty),$$

uniformly on F , so that $\operatorname{Re}(s^m)$ has an upper bound on F . Taking m and N so that $m > \delta$ and $\operatorname{Re}(s^m) \leq N$, we have, for any $\varepsilon > 0$,

$$|\phi(s)e^{\varepsilon s^m}| \leq Me^{\varepsilon N} \quad \text{on } \operatorname{Re}(s) = \nu_1 \quad \text{and} \quad \operatorname{Re}(s) = \nu_2,$$

and

$$|\phi(s)e^{\varepsilon s^m}| = O(e^{|\tau|^\delta - \varepsilon \tau^m + K|\tau|^{m-1}}) \rightarrow 0, \quad (|\tau| \rightarrow \infty)$$

uniformly on F . By the maximum principle, we see

$$|\phi(s)e^{\varepsilon s^m}| \leq Me^{\varepsilon N}, \quad (s \in F).$$

Letting ε tend to 0, we obtain $|\phi(s)| \leq M$, namely, $\phi(s) = O(|\tau|^0)$. Next assume $b \neq 0$. We define a holomorphic function $\psi(s)$ by

$$\psi(s) = (s - \nu_1 + 1)^b = e^{b \log(s - \nu_1 + 1)},$$

where \log takes the principal value. Since

$$\operatorname{Re}(\log(s - \nu_1 + 1)) = \log|s - \nu_1 + 1|,$$

we have uniformly on F

$$|\psi(s)| = |s - v_1 + 1|^b \sim |\tau|^b \quad (|\tau| \rightarrow \infty).$$

Put $\phi_1(s) = \phi(s)/\psi(s)$. Then $\phi_1(s)$ satisfies the same assumptions as ϕ with $b = 0$, so that by the above result, $\phi_1(s)$ is bounded on F . Therefore we obtain $|\phi(s)| = O(|\tau|^b)$ ($|\tau| \rightarrow \infty$). \square

As we already mentioned in §3.2, Hecke generalized the proof of Theorem 3.2.2 and proved that a transformation of a function $f(z)$ is equivalent to a functional equation of the corresponding Dirichlet series. For a holomorphic function

$$f(z) = \sum_{n=0}^{\infty} a_n e^{2\pi inz}$$

on \mathbf{H} satisfying (4.3.7), we put

$$(4.3.11) \quad L(s; f) = \sum_{n=1}^{\infty} a_n n^{-s}.$$

Since $a_n = O(n^v)$, $L(s; f)$ converges absolutely and uniformly on any compact subset of $\text{Re}(s) > 1 + v$, so that it is holomorphic on $\text{Re}(s) > 1 + v$. We call $L(s; f)$ the *Dirichlet series associated with f* . For $N > 0$, we put

$$(4.3.12) \quad A_N(s; f) = (2\pi/\sqrt{N})^{-s} \Gamma(s) L(s; f).$$

Theorem 4.3.5. (Hecke) *Let $f(z) = \sum_{n=0}^{\infty} a_n e^{2\pi inz}$ and $g(z) = \sum_{n=0}^{\infty} b_n e^{2\pi inz}$ be holomorphic functions on \mathbf{H} satisfying (4.3.7). For positive numbers k and N , the following conditions (A) and (B) are equivalent.*

(A) $g(z) = (-i\sqrt{N}z)^{-k} f(-1/Nz)$.

(B) *Both $A_N(s; f)$ and $A_N(s; g)$ can be analytically continued to the whole s -plane, satisfy the functional equation*

$$A_N(s; f) = A_N(k - s; g),$$

and

$$A_N(s; f) + \frac{a_0}{s} + \frac{b_0}{k - s}$$

is holomorphic on the whole s -plane and bounded on any vertical strip.

Proof. (A) \Rightarrow (B): Since there exists $v > 0$ such that $a_n = O(n^v)$ and $b_n = O(n^v)$,

$$\sum_{n=1}^{\infty} |a_n| e^{-2\pi nt/\sqrt{N}} \quad (t > 0)$$

and

$$\sum_{n=1}^{\infty} \int_0^{\infty} |a_n| t^{\sigma} e^{-2\pi nt/\sqrt{N}} t^{-1} dt \quad (\sigma > v + 1)$$

are convergent. Therefore we see, for $\operatorname{Re}(s) > \nu + 1$,

$$\begin{aligned}
 A_N(s; f) &= \sum_{n=1}^{\infty} a_n (2\pi n / \sqrt{N})^{-s} \int_0^{\infty} e^{-t} t^{s-1} dt \\
 &= \sum_{n=1}^{\infty} \int_0^{\infty} a_n t^s e^{-2\pi n t / \sqrt{N}} t^{-1} dt \\
 &= \int_0^{\infty} t^s \left(\sum_{n=1}^{\infty} a_n e^{-2\pi n t / \sqrt{N}} \right) t^{-1} dt \\
 &= \int_0^{\infty} t^s (f(it/\sqrt{N}) - a_0) t^{-1} dt \\
 &= -\frac{a_0}{s} + \int_1^{\infty} t^{-s} f(i/\sqrt{N}t) t^{-1} dt + \int_1^{\infty} t^s (f(it/\sqrt{N}) - a_0) t^{-1} dt.
 \end{aligned}$$

Since $g(z) = (-i\sqrt{N}z)^{-k} f(-1/Nz)$, we obtain

$$\begin{aligned}
 (4.3.13) \quad A_N(s; f) &= -\frac{a_0}{s} - \frac{b_0}{k-s} + \int_1^{\infty} t^{k-s} (g(it/\sqrt{N}) - b_0) t^{-1} dt \\
 &\quad + \int_1^{\infty} t^s (f(it/\sqrt{N}) - a_0) t^{-1} dt
 \end{aligned}$$

on $\operatorname{Re}(s) > \max\{k, \nu + 1\}$. By Lemma 4.3.3, when t tends to ∞ , we have

$$\begin{aligned}
 f(it) - a_0 &= O(e^{-2\pi t}), \\
 g(it) - b_0 &= O(e^{-2\pi t}),
 \end{aligned}$$

so that

$$\int_1^{\infty} t^s (f(it/\sqrt{N}) - a_0) t^{-1} dt$$

and

$$\int_1^{\infty} t^{k-s} (g(it/\sqrt{N}) - b_0) t^{-1} dt$$

are convergent absolutely and uniformly on any vertical strip. Therefore they are holomorphic on the whole s -plane. If we define $A_N(s; f)$ for any $s \in \mathbb{C}$ by (4.3.13), it is a meromorphic function on the whole s -plane, and

$$A_N(s; f) + \frac{a_0}{s} + \frac{b_0}{k-s}$$

is an entire function and bounded on any vertical strip. Similarly $A_N(s; g)$ is also analytically continued to the whole s -plane, and satisfies

$$\begin{aligned}
 (4.3.14) \quad A_N(k-s; g) &= -\frac{a_0}{s} - \frac{b_0}{k-s} + \int_1^{\infty} t^{k-s} (g(it/\sqrt{N}) - b_0) t^{-1} dt \\
 &\quad + \int_1^{\infty} t^s (f(it/\sqrt{N}) - a_0) t^{-1} dt.
 \end{aligned}$$

Comparing (4.3.13) and (4.3.14), we obtain $A_N(s; f) = A_N(k - s; g)$. (B) \Rightarrow (A): By (3.2.14), we have

$$f(iy) = \frac{1}{2\pi i} \sum_{n=1}^{\infty} a_n \int_{\operatorname{Re}(s)=\alpha} (2\pi ny)^{-s} \Gamma(s) ds + a_0$$

for any $\alpha > 0$. If $\alpha > \nu + 1$, then $L(s; f) = \sum_{n=1}^{\infty} a_n n^{-s}$ is uniformly convergent and bounded on $\operatorname{Re}(s) = \alpha$, so that by Stirling's estimate (3.2.8), $A_N(s; f) = (2\pi/\sqrt{N})^{-s} \Gamma(s) L(s; f)$ is absolutely integrable. Therefore we can exchange the order of summation and integration, and

$$f(iy) = \frac{1}{2\pi i} \int_{\operatorname{Re}(s)=\alpha} (\sqrt{N}y)^{-s} A_N(s; f) ds + a_0.$$

Since $L(s; f)$ is bounded on $\operatorname{Re}(s) = \alpha$, we see, for any $\mu > 0$,

$$(4.3.15) \quad |A_N(s; f)| = O(|\operatorname{Im}(s)|^{-\mu}) \quad (|\operatorname{Im}(s)| \rightarrow \infty)$$

on $\operatorname{Re}(s) = \alpha$ by Stirling's estimate. Next take β so that $k - \beta > \nu + 1$. A similar argument implies that for any $\mu > 0$,

$$|A_N(s; f)| = |A_N(k - s; g)| = O(|\operatorname{Im}(s)|^{-\mu}) \quad (|\operatorname{Im}(s)| \rightarrow \infty)$$

on $\operatorname{Re}(s) = \beta$. By assumption,

$$A_N(s; f) + \frac{a_0}{s} + \frac{b_0}{k - s}$$

is bounded on the domain $\beta \leq \operatorname{Re}(s) \leq \alpha$. Hence for any $\mu > 0$, we see by Lemma 4.3.4,

$$(4.3.16) \quad (4.3.15) \text{ holds uniformly on the domain } \beta \leq \operatorname{Re}(s) \leq \alpha.$$

Furthermore we assume that $\alpha > k$ and $\beta < 0$. Since $(\sqrt{N}y)^{-s} A_N(s; f)$ has simple poles at $s = 0$ and $s = k$ with the residues $-a_0$ and $(\sqrt{N}y)^{-k} b_0$, respectively, we can change the integral paths from $\operatorname{Re}(s) = \alpha$ to $\operatorname{Re}(s) = \beta$ using (4.3.16) and obtain

$$f(iy) = \frac{1}{2\pi i} \int_{\operatorname{Re}(s)=\beta} (\sqrt{N}y)^{-s} A_N(s; f) ds + (\sqrt{N}y)^{-k} b_0.$$

By the functional equation,

$$\begin{aligned} f(iy) &= \frac{1}{2\pi i} \int_{\operatorname{Re}(s)=\beta} (\sqrt{N}y)^{-s} A_N(k - s; g) ds + (\sqrt{N}y)^{-k} b_0 \\ &= \frac{1}{2\pi i} \int_{\operatorname{Re}(s)=k-\beta} (\sqrt{N}y)^{s-k} A_N(s; g) ds + (\sqrt{N}y)^{-k} b_0 \\ &= (\sqrt{N}y)^{-k} g(-1/iNy). \end{aligned}$$

Since $f(z)$ and $g(z)$ are holomorphic on \mathbf{H} , we obtain

$$f(z) = (\sqrt{N}z/i)^{-k} g(-1/Nz),$$

or

$$g(z) = (-i\sqrt{Nz})^{-k} f(-1/Nz).$$

As a special case, we let $k = 1/2$, $N = 4$ and

$$f(z) = g(z) = \frac{1}{2} \theta(z) = \frac{1}{2} + \sum_{n=1}^{\infty} e^{2\pi i n^2 z}.$$

Then (A) is nothing but the theta transformation formula (3.2.17), so that the functional equation of the Riemann zeta-function in §3.2 is the special case of the part (A) \Rightarrow (B) of the above theorem.

For latter use, we restate the above theorem.

Theorem 4.3.6. *Let k and N be positive integers. For two holomorphic functions $f(z) = \sum_{n=0}^{\infty} a_n e^{2\pi i n z}$ and $g(z) = \sum_{n=0}^{\infty} b_n e^{2\pi i n z}$ on \mathbf{H} satisfying (4.3.7), the following conditions are equivalent:*

(A) $g(z) = (\sqrt{Nz})^{-k} f(-1/Nz) \quad (= (f|_k \omega_N)(z)).$

(B) *Both $A_N(s; f)$ and $A_N(s; g)$ can be analytically continued to the whole s -plane, satisfy the functional equation*

$$A_N(s; f) = i^k A_N(k - s; g),$$

and the function

$$A_N(s; f) + \frac{a_0}{s} + \frac{i^k b_0}{k - s}$$

is holomorphic on the whole s -plane and bounded on any vertical strip.

Since any element $f(z)$ of $\mathcal{S}_k(N, \chi)$ satisfies (4.3.7), we obtain the following

Corollary 4.3.7. *For any element $f(z)$ of $\mathcal{S}_k(N, \chi)$, $A_N(s; f)$ is holomorphic on the whole s -plane and satisfies the functional equation*

$$A_N(s; f) = i^k A_N(k - s; f|_k \omega_N).$$

We note that the functional equation in Corollary 4.3.7 is also satisfied for any element of $\mathcal{G}_k(N, \chi)$ (see §4.7). It is unknown for an arbitrary Fuchsian group whether a non-cusp form $f(z)$ satisfies (4.3.7) or not. For modular groups, we will construct elements of the space of Eisenstein series $\mathcal{N}_k(N, \chi)$ using Dirichlet L -functions in §4.7. Therefore we can prove the functional equation for any element of $\mathcal{G}_k(N, \chi)$.

Since $\Gamma(1)$ is generated by two elements $\begin{bmatrix} 1 & 1 \\ 0 & 1 \end{bmatrix}$ and $\begin{bmatrix} 0 & -1 \\ 1 & 0 \end{bmatrix}$, we can easily characterize an element $f(z)$ of $\mathcal{G}_k(\Gamma(1))$ by the functional equation of $L(s; f)$ and obtain

Theorem 4.3.8. *Let k be an even integer ≥ 2 . Assume a holomorphic function $f(z)$ on \mathbf{H} satisfies (4.3.7). Then $f(z)$ belongs to $\mathcal{G}_k(\Gamma(1))$ if and only if $A(s; f) = (2\pi)^{-s} \Gamma(s) L(s; f)$ can be analytically continued to the whole s -plane,*

$$A(s; f) + \frac{a_0}{s} + \frac{(-1)^{k/2} a_0}{k - s}$$

is holomorphic on \mathbf{H} and bounded on any vertical strip, and satisfies the functional equation:

$$\Lambda(s; f) = (-1)^{k/2} \Lambda(k - s; f).$$

Moreover if $a_0 = 0$, then $f(z)$ is a cusp form.

The situation for $\mathcal{G}_k(N, \chi)$ is much more complicated, since $\Gamma_0(N)$ has many generators. For a holomorphic function $f(z)$ satisfying (4.3.7) and a Dirichlet character ψ , we put

$$(4.3.17) \quad f_\psi(z) = \sum_{n=0}^{\infty} \psi(n) a_n e^{2\pi i n z},$$

and

$$(4.3.18) \quad L(s; f, \psi) = \sum_{n=1}^{\infty} \psi(n) a_n n^{-s}.$$

This is an analogue of the Dirichlet L -function to the Riemann zeta-function. It is obvious that $f_\psi(z)$ also satisfies (4.3.7) by (4.3.8) and Lemma 4.3.3. Let $m = m_\psi$ be the conductor of ψ , and put

$$(4.3.19) \quad A_N(s; f, \psi) = (2\pi/m\sqrt{N})^{-s} \Gamma(s) L(s; f, \psi).$$

By definition,

$$(4.3.20) \quad \begin{aligned} L(s; f_\psi) &= L(s; f, \psi), \\ A_{Nm^2}(s; f_\psi) &= A_N(s; f, \psi). \end{aligned}$$

Lemma 4.3.9. *Let $f(z)$ and $g(z)$ be two holomorphic functions on \mathbf{H} satisfying (4.3.7), and ψ a primitive Dirichlet character of conductor $m (> 1)$. Then the following conditions (A_ψ) and (B_ψ) are equivalent.*

$$(A_\psi) \quad f_\psi|_k \omega(Nm^2) = C_\psi g_{\bar{\psi}}.$$

(B_ψ) $A_N(s; f, \psi)$ can be holomorphically continued to the whole s -plane, bounded on any vertical strip, and satisfies the functional equation:

$$A_N(s; f, \psi) = i^k C_\psi A_N(k - s; g, \bar{\psi})$$

for a constant C_ψ .

Proof. Apply Theorem 4.3.6 for f_ψ , $C_\psi g_{\bar{\psi}}$, and Nm^2 in place of f , g , and N , respectively. Then we obtain the theorem by (4.3.20). \square

We put

$$\alpha(a) = \begin{bmatrix} 1 & a \\ 0 & 1 \end{bmatrix} \quad (a \in \mathbb{R}).$$

Lemma 4.3.10. (1) *Let f be a holomorphic function on \mathbf{H} satisfying (4.3.7), and ψ a primitive Dirichlet character of conductor m . Then for an integer $k > 0$, we have*

$$f_\psi = W(\bar{\psi})^{-1} \sum_{u=1}^m \bar{\psi}(u) (f|_k \alpha(u/m)),$$

where $W(\bar{\psi})$ is the Gauss sum of $\bar{\psi}$.

(2) Let $f(z)$ be an element of $\mathcal{G}_k(N, \chi)$, m_x the conductor of χ , ψ a primitive Dirichlet character of conductor m_ψ , and M the least common multiple of N , m_ψ^2 , and $m_\psi m_x$. Then f_ψ belongs to $\mathcal{G}_k(M, \chi\psi^2)$. Moreover if f is a cusp form, so is f_ψ .

Proof. (1): Since for an integer u , we have

$$(f|_k \alpha(u/m))(z) = \sum_{n=0}^{\infty} a_n e^{2\pi i n u/m} e^{2\pi i n z},$$

we see by Lemma 3.1.1(1)

$$(4.3.21) \quad \sum_{u=1}^m \bar{\psi}(u) (f|_k \alpha(u/m))(z) = \sum_{n=0}^{\infty} \left(\sum_{u=1}^m \bar{\psi}(u) e^{2\pi i n u/m} \right) a_n e^{2\pi i n z} \\ = W(\bar{\psi}) f_\psi(z).$$

(2): Assume $f \in \mathcal{G}_k(N, \chi)$ and put $m = m_\psi$. Since

$$\alpha(u/m)^{-1} \Gamma_0(N) \alpha(u/m) \supset \Gamma(Nm^2),$$

$f|_k \alpha(u/m)$ belongs to $\mathcal{G}_k(\Gamma(Nm^2))$. By (1) we see $f_\psi \in \mathcal{G}_k(\Gamma(Nm^2))$. Therefore we have

only to prove that $f_\psi|_k \gamma = (\chi\psi^2)(\gamma) f_\psi$ for all $\gamma \in \Gamma_0(M)$. Let $\gamma = \begin{bmatrix} a & b \\ cM & d \end{bmatrix} \in \Gamma_0(M)$

and put

$$\gamma' = \alpha(u/m) \gamma \alpha(d^2 u/m)^{-1},$$

then $\gamma' \in \Gamma_0(M) \subset \Gamma_0(N)$. Writing $\gamma' = \begin{bmatrix} a' & b' \\ c' & d' \end{bmatrix}$, we have

$$d' = d - cd^2 uM/m \equiv d \pmod{m_x},$$

so that

$$f|_k \alpha(u/m) \gamma = \chi(d) f|_k \alpha(d^2 u/m).$$

Hence by (4.3.21), we obtain

$$f_\psi|_k \gamma = \chi(d) \psi(d^2) f_\psi.$$

A similar argument is applicable to cusp forms. □

Theorem 4.3.11. Let $f(z)$ be an element of $\mathcal{G}_k(N, \chi)$, and ψ a primitive Dirichlet character of conductor m . If $(m, N) = 1$, then

$$f_\psi|_k \omega(Nm^2) = C_\psi g_{\bar{\psi}},$$

where $g = f|_k \omega_N$ and

$$C_\psi = C_{N, \psi} = \chi(m) \psi(-N) W(\psi) / W(\bar{\psi}) \\ = \chi(m) \psi(N) W(\psi)^2 / m.$$

Proof. For an integer u prime to m , take integers n, v so that $nm - Nuv = 1$. Then

$$(4.3.22) \quad \alpha(u/m) \omega(Nm^2) = m \cdot \omega(N) \begin{bmatrix} m & -v \\ -uN & n \end{bmatrix} \alpha(v/m).$$

Since $g = f|_k \omega_N$ belongs to $\mathcal{S}_k(N, \bar{\chi})$ by Lemma 4.3.2, (4.3.22) implies

$$f|_k \alpha(u/m) \omega(Nm^2) = \chi(m) g|_k \alpha(v/m),$$

so that

$$\begin{aligned} W(\bar{\psi}) f_{\bar{\psi}}|_k \omega(Nm^2) &= \sum_{u=1}^m \bar{\psi}(u) f|_k \alpha(u/m) \omega(Nm^2) \\ &= \chi(m) \sum_{v=1}^m \psi(-Nv) g|_k \alpha(v/m) \\ &= \chi(m) \psi(-N) \sum_{v=1}^m \psi(v) g|_k \alpha(v/m) \\ &= \chi(m) \psi(-N) W(\psi) g_{\bar{\psi}}. \end{aligned} \quad \square$$

By this theorem and Lemma 4.3.9, we obtain the following

Theorem 4.3.12. *Let $f(z)$ be an element of $\mathcal{S}_k(N, \chi)$, and ψ a primitive Dirichlet character of conductor m . If $(m, N) = 1$, then $A_N(s; f, \psi)$ can be holomorphically continued to the whole s -plane, is bounded on any vertical strip, and satisfies the functional equation:*

$$A_N(s; f, \psi) = i^k C_{\psi} A_N(k - s; f|_k \omega_N, \bar{\psi}),$$

where C_{ψ} is the constant in Theorem 4.3.11.

To prove the converse of this theorem is the purpose of the rest of this section. For two integers m, v such that $(m, vN) = 1$, take integers n, u so that $mn - uvN = 1$, and put

$$\gamma(m, v) = \begin{bmatrix} m & -v \\ -uN & n \end{bmatrix} \in \Gamma_0(N).$$

Though $\gamma(m, v)$ is not uniquely determined, $u \pmod m$ is uniquely determined, and

$$(4.3.23) \quad \alpha(u/m) \omega(Nm^2) = m \cdot \omega(N) \gamma(m, v) \alpha(v/m).$$

We now extend the action of $GL_2^+(\mathbb{R})$ on functions on \mathbf{H} linearly to the group algebra $\mathbb{C}[GL_2^+(\mathbb{R})]$. For a function $f(z)$ on \mathbf{H} , we put

$$(4.3.24) \quad f|_k \beta = \sum_{\alpha} a_{\alpha} f|_k \alpha \quad \text{for} \quad \beta = \sum_{\alpha} a_{\alpha} \alpha \in \mathbb{C}[GL_2^+(\mathbb{R})].$$

In the following two lemmas, k and N are positive integers, χ is a Dirichlet character mod N satisfying $\chi(-1) = (-1)^k$, and $f(z)$ and $g(z)$ are holomorphic functions on \mathbf{H} satisfying (4.3.7) and condition (A) of Theorem 4.3.6.

Lemma 4.3.13. *Let m be an odd prime number or 4 prime to N . If $f(z)$ and $g(z)$ satisfy condition (A _{ψ}) in Lemma 4.3.9 for all primitive Dirichlet characters $\psi \pmod m$ with the constant*

$$C_{\psi} = \chi(m) \psi(-N) W(\psi) / W(\bar{\psi}),$$

then

$$g|_k(\chi(m) - \gamma(m, u))\alpha(u/m) = g|_k(\chi(m) - \gamma(m, v))\alpha(v/m)$$

for any integers u and v prime to m .

Proof. By the assumption (A_ψ) and Lemma 4.3.10, we see

$$(4.3.25) \quad \sum_{u=1}^m \bar{\psi}(u) f|_k \alpha(u/m) \omega(Nm^2) = \chi(m) \psi(-N) \sum_{u=1}^m \psi(u) g|_k \alpha(u/m).$$

For each integer u prime to m , take an integer v so that $-uvN \equiv 1 \pmod{m}$. Then we have by (4.3.23)

$$(4.3.26) \quad f|_k \alpha(u/m) \omega(Nm^2) = g|_k \gamma(m, v) \alpha(v/m).$$

Since the left-hand side is independent of the choice of a representative of $u \pmod{m}$, so is the right-hand side of the choice of $\gamma(m, v)$. Using (4.3.26), we rewrite (4.3.25) into

$$(4.3.27) \quad \sum_v \psi(v) g|_k (\chi(m) - \gamma(m, v)) \alpha(v/m) = 0.$$

Here v runs over a complete set of representatives of $\mathbb{Z}/m\mathbb{Z}$. We note that (4.3.27) is independent of the choice of representatives of $\mathbb{Z}/m\mathbb{Z}$. Let v_1, v_2 be two integers prime to m . Multiply both sides of (4.3.27) by $\bar{\psi}(v_1) - \bar{\psi}(v_2)$ and take the summations with respect to all nontrivial Dirichlet characters $\psi \pmod{m}$. Noting that $\bar{\psi}(v_1) - \bar{\psi}(v_2) = 0$ if ψ is trivial, we obtain

$$g|_k(\chi(m) - \gamma(m, v_1))\alpha(v_1/m) = g|_k(\chi(m) - \gamma(m, v_2))\alpha(v_2/m). \quad \square$$

Lemma 4.3.14. *Let m and n be odd prime numbers or 4. Assume both m and n are prime to N . If $f(z)$ and $g(z)$ satisfy condition (A_ψ) in Lemma 4.3.9 with the constant $C_\psi = \chi(m_\psi) \psi(-N) W(\psi) / W(\psi)$ for any primitive Dirichlet character ψ whose conductor $m_\psi = m$ or n , then*

$$g|_k \gamma = \bar{\chi}(\gamma) g$$

for all $\gamma \in \Gamma_0(N)$ of the form $\gamma = \begin{bmatrix} m & -v \\ -uN & n \end{bmatrix}$.

Proof. Put $\gamma' = \begin{bmatrix} m & v \\ uN & n \end{bmatrix}$. Since we can take γ and γ' for $\gamma(m, v)$ and $\gamma(m, -v)$ in Lemma 4.3.13, respectively, we have

$$g|_k(\chi(m) - \gamma')\alpha(-v/m) = g|_k(\chi(m) - \gamma)\alpha(v/m),$$

so that

$$(4.3.28) \quad g|_k(\chi(m) - \gamma')\alpha(-2v/m) = g|_k(\chi(m) - \gamma).$$

We can also take $\gamma'^{-1} = \begin{bmatrix} n & -v \\ -uN & m \end{bmatrix}$ and $\gamma^{-1} = \begin{bmatrix} n & v \\ uN & m \end{bmatrix}$ for $\gamma(n, v)$ and $\gamma(n, -v)$, and obtain

$$(4.3.29) \quad g|_k(\chi(n) - \gamma'^{-1}) = g|_k(\chi(n) - \gamma^{-1})\alpha(-2v/n).$$

Since $\chi(n)\chi(m) = 1$, we see

$$(4.3.30) \quad \begin{aligned} \chi(n) - \gamma'^{-1} &= -\chi(n)(\chi(m) - \gamma')\gamma'^{-1}, \\ (\chi(n) - \gamma'^{-1})\alpha(-2v/n) &= -\chi(n)(\chi(m) - \gamma)\gamma^{-1}\alpha(-2v/n) \end{aligned}$$

as elements of $\mathbb{C}[GL_2^+(\mathbb{R})]$. Rewriting (4.3.29) by using (4.3.30), we have

$$(4.3.31) \quad g|_k(\chi(m) - \gamma') = g|_k(\chi(m) - \gamma)\gamma^{-1}\alpha(-2v/n)\gamma',$$

so that from (4.3.28)

$$(4.3.32) \quad g|_k(\chi(m) - \gamma)(1 - \gamma^{-1}\alpha(-2v/n)\gamma'\alpha(-2v/m)) = 0.$$

Put

$$h = g|_k(\chi(m) - \gamma) = \chi(m)g - g|_k\gamma.$$

The function $h(z)$ is holomorphic on \mathbf{H} and satisfies

$$(4.3.33) \quad \begin{aligned} h|_k\beta &= h, \\ \beta &= \gamma^{-1}\alpha(-2v/n)\gamma'\alpha(-2v/m) = \begin{bmatrix} 1 & -2v/m \\ 2uN/n & 4/mn - 3 \end{bmatrix}. \end{aligned}$$

Since $|\text{tr}(\beta)| = |4/mn - 2| < 2$, and $|\text{tr}(\beta)| \neq 0, 1$ by the assumption on m and n , β is elliptic and any eigenvalue of β is not a root of unity. In fact, since the entries of β are all rational numbers, the eigenvalues of β belong to a quadratic field. Hence if an eigenvalue of β is a root of unity, then it must be $\pm 1, \pm i, \pm e^{\pi i/3}$ or $\pm e^{2\pi i/3}$, so that $\text{tr}(\beta) = 0, \pm 1$, or ± 2 , which is a contradiction. Let now z_0 be a point of \mathbf{H} fixed by β . Put

$$\begin{aligned} \rho &= (z_0 - \bar{z}_0)^{-1} \begin{bmatrix} 1 & -z_0 \\ 1 & -\bar{z}_0 \end{bmatrix} \in GL_2(\mathbb{C}), \\ p(w) &= (h|_k\rho^{-1})(w) = j(\rho^{-1}, w)^{-k}h(\rho^{-1}w) \quad (w \in \mathbf{K}). \end{aligned}$$

Then $p(w)$ is holomorphic on \mathbf{K} . Since we can write $\rho\beta\rho^{-1} = \begin{bmatrix} \zeta & 0 \\ 0 & \zeta^{-1} \end{bmatrix}$ with $\zeta \in \mathbb{C}$, we see by (4.3.33)

$$(4.3.34) \quad p(\zeta^2 w) = \zeta^{-k}p(w).$$

Let $p(w) = \sum_{n=0}^{\infty} a_n w^n$ be the Taylor expansion at $w = 0$, then we get

$$\zeta^{2n} a_n = \zeta^{-k} a_n$$

for all n . Since ζ is an eigenvalue of β which is not a root of unity, we obtain $a_n = 0$ for all n . Therefore $h(z) = 0$, so that $g|_k\gamma = \chi(m)g = \bar{\chi}(\gamma)g$. \square

Now we are ready to state the main theorem in this section. For two coprime positive integers a and b , we put

$$(4.3.35) \quad A(a, b) = \{a + nb | n \in \mathbb{Z}\}.$$

Let M be a set of odd prime numbers or 4 satisfying the following two conditions:

- (i) any element of M is prime to N ;
- (ii) $M \cap A(a, b) \neq \emptyset$ for any $A(a, b)$.

There exists such a set M . We can take as M , for example, the set of all odd prime numbers prime to N by Dirichlet's theorem on arithmetic progression.

Theorem 4.3.15. (Weil) *Let k and N be two positive integers, and χ a Dirichlet character mod N such that $\chi(-1) = (-1)^k$. For two sequences $\{a_n\}_{n=0}^\infty$ and $\{b_n\}_{n=0}^\infty$ of complex numbers such that $a_n = O(n^v)$, $b_n = O(n^v)$ ($v > 0$), put*

$$f(z) = \sum_{n=0}^\infty a_n e^{2\pi i n z}$$

and

$$g(z) = \sum_{n=0}^\infty b_n e^{2\pi i n z} \quad (z \in \mathbf{H}).$$

Then $f(z) \in \mathcal{G}_k(N, \chi)$, $g(z) \in \mathcal{G}_k(N, \bar{\chi})$ and $g = f|_k \omega_N$, if the following two conditions are satisfied:

- (1) $A_N(s; f)$ and $A_N(s; g)$ satisfy condition (B) in Theorem 4.3.6;
- (2) for any primitive Dirichlet character ψ whose conductor m_ψ belongs to M , $A_N(s; f, \psi)$ and $A_N(s; g, \psi)$ satisfy condition (B $_\psi$) in Lemma 4.3.9 with the constant

$$C_\psi = C_{N, \psi} = \chi(m_\psi) \psi(-N) W(\psi) / W(\bar{\psi}).$$

Moreover, if $L(s; f)$ is absolutely convergent at $s = k - \delta$ for $\delta > 0$, then $f(z)$ and $g(z)$ are cusp forms.

Proof. We shall prove that $g|_k \gamma = \bar{\chi}(\gamma) g$ for $\gamma = \begin{bmatrix} a & b \\ cN & d \end{bmatrix} \in \Gamma_0(N)$. If $c = 0$, then $a = d = \pm 1$, so that $g|_k \gamma = \bar{\chi}(d) g = \bar{\chi}(\gamma) g$ since $\chi(-1) = (-1)^k$. Next assume $c \neq 0$. Since $(a, cN) = (d, cN) = 1$, there exist integers s, t such that $a + tcN \in M$, and $d + scN \in M$ by condition (ii). Put

$$\begin{aligned} m &= a + tcN, & n &= d + scN, \\ u &= -c, & v &= -(b + sm + stuN + nt), \end{aligned}$$

then

$$\begin{bmatrix} a & b \\ cN & d \end{bmatrix} = \begin{bmatrix} 1 & -t \\ 0 & 1 \end{bmatrix} \begin{bmatrix} m & -v \\ -uN & n \end{bmatrix} \begin{bmatrix} 1 & -s \\ 0 & 1 \end{bmatrix}.$$

Hence Lemma 4.3.14 implies

$$g|_k \gamma = \bar{\chi}(n) g = \bar{\chi}(d) g = \bar{\chi}(\gamma) g.$$

Now $g(z) = O(y^{-v-1})$ by Lemma 4.3.3, so that $g(z) \in \mathcal{G}_k(N, \bar{\chi})$ by Theorem 2.1.4. Since $f = (-1)^k g|_k \omega_N$ by (1), we get $f(z) \in \mathcal{G}_k(N, \chi)$ by Lemma 4.3.2(2). This implies the first half of the assertion. Next assume that $L(s; f)$ is absolutely convergent at

$s = k - \delta$ with $\delta > 0$. Put

$$c_0 = 0,$$

$$c_n = \sum_{m=1}^n |a_m| \quad (n \geq 1),$$

then

$$c_n \leq n^{k-\delta} \left(\sum_{m=1}^{\infty} |a_m| m^{-k+\delta} \right),$$

so that $c_n = O(n^{k-\delta})$. By Lemma 4.3.3, $\sum_{n=0}^{\infty} c_n e^{-2\pi ny}$ is convergent and $\sum_{n=0}^{\infty} c_n e^{-2\pi ny} = O(y^{-k+\delta-1})$ ($y \rightarrow 0$). Since $|a_n| = c_n - c_{n-1}$, we see

$$|f(z) - a_0| \leq (1 - e^{-2\pi y}) \left(\sum_{n=1}^{\infty} c_n e^{-2\pi ny} \right),$$

so that $f(z) = O(y^{-k+\delta})$. Therefore $f(z)$ is a cusp form by Theorem 2.1.4, and so is $g(z)$. \square

We note that when N is not a prime number, $f(z)$ and $g(z)$ are not necessarily cusp forms even if $a_0 = b_0 = 0$.

§4.4. $\Delta(z)$ and $\eta(z)$

In this section, we give the proof of Theorem 4.1.7(2) which asserts that $\Delta(z)$ has no zeros on \mathbf{H} . First we define the function $\eta(z)$ on \mathbf{H} by

$$\eta(z) = e^{\pi iz/12} \prod_{n=1}^{\infty} (1 - e^{2\pi inz}).$$

Since $\sum_{n=1}^{\infty} e^{2\pi inz}$ converges absolutely and uniformly on any compact subset of \mathbf{H} , so does the above infinite product. We call $\eta(z)$ the *Dedekind η -function*.

Theorem 4.4.1. *The function $\eta(z)$ satisfies the transformation formula*

$$\eta(-1/z) = (z/i)^{1/2} \eta(z).$$

Proof. We follow Weil's proof ([Weil 4]) which reduces a transformation formula for a holomorphic function on \mathbf{H} to a functional equation of the corresponding Dirichlet series. Since $\eta(z)$ has no zeros on \mathbf{H} , the assertion is equivalent to saying that

$$(4.4.1) \quad \log \eta(-1/z) = \log \eta(z) + \frac{1}{2} \log(z/i).$$

By definition, we have

$$\log \eta(z) = \pi iz/12 - \sum_{m,n=1}^{\infty} m^{-1} e^{2\pi imnz}.$$

Put

$$f(z) = \sum_{m,n=1}^{\infty} m^{-1} e^{2\pi i m n z} = \pi i z / 12 - \log \eta(z),$$

then $f(z)$ satisfies (4.3.7) and

$$L(s; f) = \zeta(s) \zeta(s+1).$$

As in the previous section, put

$$\Lambda(s; f) = (2\pi)^{-s} \Gamma(s) L(s; f)$$

and

$$\Lambda(s) = \pi^{-s/2} \Gamma(s/2) \zeta(s).$$

Since

$$\Lambda(s; f) = \frac{1}{2} \Lambda(s) \Lambda(s+1),$$

Theorem 3.2.2 implies that $\Lambda(s; f)$ can be analytically continued to the whole s -plane and satisfies the functional equation

$$\Lambda(s; f) = \Lambda(-s; f).$$

Moreover $\zeta(-1) = -1/12$, and

$$(4.4.2) \quad \Lambda(s; f) - \frac{\pi}{12(s-1)} + \frac{\pi}{12(s+1)} + \frac{1}{2s^2}$$

is entire and bounded on any vertical strip. We note here that

$$\Lambda(s) + \frac{1}{s} + \frac{1}{1-s}$$

is bounded on any vertical strip by a similar argument as in the proof of Theorem 4.3.5. Now

$$f(iy) = \frac{1}{2\pi i} \int_{\operatorname{Re}(s)=2} y^{-s} \Lambda(s; f) ds,$$

and we can change the integral paths from $\operatorname{Re}(s)=2$ to $\operatorname{Re}(s)=-2$. By the holomorphy of (4.4.2), $y^{-s} \Lambda(s; f)$ has poles only at $s=1, 0, -1$ with the residues $\pi/12y, \frac{1}{2} \log y, -\pi y/12$, respectively. Hence

$$\begin{aligned} f(iy) &= \frac{1}{2\pi i} \int_{\operatorname{Re}(s)=-2} y^{-s} \Lambda(s; f) ds + \pi/12y + \frac{1}{2} \log y - \pi y/12 \\ &= \frac{1}{2\pi i} \int_{\operatorname{Re}(s)=2} y^s \Lambda(-s; f) ds + \pi/12y + \frac{1}{2} \log y - \pi y/12 \\ &= f(-1/iy) + \pi/12y + \frac{1}{2} \log y - \pi y/12, \end{aligned}$$

by the functional equation for $\Lambda(s; f)$. Therefore (4.4.1) holds on the imaginary axis. Since both sides are holomorphic on \mathbf{H} , (4.4.1) is satisfied everywhere on \mathbf{H} . \square

Now we consider $\eta^{24}(z)$. Since

$$(4.4.3) \quad \eta^{24}(z) = e^{2\pi iz} \prod_{n=1}^{\infty} (1 - e^{2\pi inz})^{24},$$

we have

$$(4.4.4) \quad \eta^{24}(z+1) = \eta^{24}(z), \quad \eta^{24}(-1/z) = z^{12} \eta^{24}(z).$$

As $\Gamma(1)$ is generated by $\begin{bmatrix} 1 & 1 \\ 0 & 1 \end{bmatrix}$ and $\begin{bmatrix} 0 & -1 \\ 1 & 0 \end{bmatrix}$ and $\eta^{24}(z)$ vanishes at ∞ by (4.4.3),

$$\eta^{24}(z) \in \mathcal{S}_{12}(\Gamma(1)).$$

Since $\dim \mathcal{S}_{12}(\Gamma(1)) = 1$, we see $\eta^{24}(z) = c\Delta(z)$ with a constant c . Comparing the first Fourier coefficients of $\eta^{24}(z)$ and $\Delta(z)$, we get $c = 1$, hence

$$\Delta(z) = \eta^{24}(z).$$

Thus we obtain the following

Theorem 4.4.2. *The function $\Delta(z)$ has no zeros on \mathbf{H} and has the infinite product expansion*

$$\Delta(z) = e^{2\pi iz} \prod_{n=1}^{\infty} (1 - e^{2\pi inz})^{24},$$

which converges absolutely and uniformly on any compact subset of \mathbf{H} .

Theorem 4.4.2 also implies the integrality of the Fourier coefficients τ_n of $\Delta(z)$. The explicit forms of $\Delta(z)$ and $\eta(z)$ are quite useful to calculate modular forms. We can construct cusp forms of small level by using $\Delta(z)$ and $\eta(z)$. For example, we have ([Shimura], pp. 49–50):

1° If N is 2, 3, 5, or 11, and $k = 24/(N + 1)$, then $\mathcal{S}_k(\Gamma_0(N))$ is one-dimensional and is generated by

$$(\Delta(z)\Delta(Nz))^{1/(N+1)} = (\eta(z)\eta(Nz))^k.$$

2° If N is 2, 3, 4, 6 or 12, and $k = 12/N$, then $\mathcal{S}_k(\Gamma(N))$ is also one-dimensional and is generated by

$$(\Delta(z))^{1/N} = \eta^{2k}(z).$$

§4.5. Hecke Algebras of Modular Groups

Hecke operators play important roles in the study of modular forms. In this section, we explain, following Shimura, the relation between Fourier coefficients of modular forms and Hecke operators first obtained by Hecke. We begin by studying the structure of the Hecke algebras of modular groups. For a Fuchsian group Γ , we put

$$\tilde{\Gamma} = \{g \in GL_2^+(\mathbb{R}) \mid g\Gamma g^{-1} \approx \Gamma\}.$$

Lemma 4.5.1. *For any modular group Γ , we have*

$$\tilde{\Gamma} = \mathbb{R}^\times \cdot GL_2^+(\mathbb{Q}).$$

Proof. Since $\Gamma \approx \Gamma(1)$, we have only to prove the lemma for $\Gamma = \Gamma(1)$ by Lemma 2.7.1(3). Let $\alpha \in \mathbb{R}^\times \cdot GL_2^+(\mathbb{Q})$. Take $c \in \mathbb{R}^\times$ so that $\beta = c\alpha \in M_2(\mathbb{Z})$. Then $\alpha^{-1}\Gamma(1)\alpha = \beta^{-1}\Gamma(1)\beta$. Put $m = \det(\beta)$, then $m\beta^{-1} \in M_2(\mathbb{Z})$. For any $\gamma \in \Gamma(m)$, we see

$$(m\beta^{-1})\gamma\beta \equiv (m\beta^{-1})\beta \pmod{m}, \quad \left(= \begin{bmatrix} m & 0 \\ 0 & m \end{bmatrix} \right)$$

so that $\beta^{-1}\gamma\beta \in M_2(\mathbb{Z})$, and $\beta^{-1}\Gamma(m)\beta \subset \Gamma$. Therefore we have

$$\alpha\Gamma\alpha^{-1} \cap \Gamma = \beta\Gamma\beta^{-1} \cap \Gamma \supset \Gamma(m).$$

Since $[\Gamma : \Gamma(m)] < \infty$, α belongs to $\tilde{\Gamma}$. Conversely, assume $\alpha = \begin{bmatrix} a & b \\ c & d \end{bmatrix} \in \tilde{\Gamma}$. By Corollary 1.5.5, the cusps $\alpha\infty = a/c$ and $\alpha 0 = b/d$ of $\alpha\Gamma\alpha^{-1}$ are also cusps of Γ . Since $\Gamma \approx {}'\alpha^{-1}\Gamma'\alpha$, the points $'\alpha\infty = a/b$ and $'\alpha 0 = c/d$ are also cusps of Γ . As any cusp of Γ is an element of $\mathbb{Q} \cup \{\infty\}$, the ratios of a, b, c, d are all rational numbers, and therefore $\alpha \in \mathbb{R}^\times \cdot GL_2^+(\mathbb{Q})$. \square

We define the subsemigroups $\Delta_0(N)$ and $\Delta_0^*(N)$ of $GL_2^+(\mathbb{Q})$ by

$$(4.5.1) \quad \Delta_0(N) = \left\{ \begin{bmatrix} a & b \\ c & d \end{bmatrix} \in M_2(\mathbb{Z}) \mid c \equiv 0 \pmod{N}, (a, N) = 1, ad - bc > 0 \right\},$$

and

$$(4.5.2) \quad \Delta_0^*(N) = \left\{ \begin{bmatrix} a & b \\ c & d \end{bmatrix} \in M_2(\mathbb{Z}) \mid c \equiv 0 \pmod{N}, (d, N) = 1, ad - bc > 0 \right\}.$$

We see easily that

$$(4.5.3) \quad \Delta_0(N) \cap \Delta_0^*(N) = \left\{ \begin{bmatrix} a & b \\ c & d \end{bmatrix} \in M_2(\mathbb{Z}) \mid c \equiv 0 \pmod{N}, (ad - bc, N) = 1, ad - bc > 0 \right\}.$$

We are going to study Hecke algebras $\mathcal{R}(\Gamma_0(N), \Delta_0(N))$ and $\mathcal{R}(\Gamma_0(N), \Delta_0^*(N))$. We simply write

$$(4.5.4) \quad \mathcal{R}(N) = \mathcal{R}(\Gamma_0(N), \Delta_0(N)),$$

$$(4.5.5) \quad \mathcal{R}^*(N) = \mathcal{R}(\Gamma_0(N), \Delta_0^*(N)).$$

Lemma 4.5.2. *For any $\alpha \in \Delta_0(N)$ (resp. $\Delta_0^*(N)$), there exist positive integers l and m such that $l|m$, $(l, N) = 1$ and*

$$\Gamma_0(N)\alpha\Gamma_0(N) = \Gamma_0(N) \begin{bmatrix} l & 0 \\ 0 & m \end{bmatrix} \Gamma_0(N)$$

$$\text{(resp. } \Gamma_0(N)\alpha\Gamma_0(N) = \Gamma_0(N) \begin{bmatrix} m & 0 \\ 0 & l \end{bmatrix} \Gamma_0(N)).$$

The pair (l, m) is uniquely determined by α .

Proof. Put

$$L = \left\{ \begin{bmatrix} u \\ v \end{bmatrix} \mid u, v \in \mathbb{Z} \right\}, \quad L_0 = \left\{ \begin{bmatrix} u \\ Nv \end{bmatrix} \mid u, v \in \mathbb{Z} \right\}.$$

Then $M_2(\mathbb{Z})$ acts on L by left multiplication and $\alpha L_0 \subset L_0$. Put $n = \det(\alpha)$, then

$$[L : \alpha L_0] = [L : \alpha L][\alpha L : \alpha L_0] = nN.$$

By the fundamental theorem of abelian groups, there exists a basis $\{w_1, w_2\}$ of L such that

$$\alpha L_0 = \mathbb{Z}(aw_1) \oplus \mathbb{Z}(bw_2)$$

with positive integers a and b ($ab = nN$, $a \mid b$). Since $\alpha L_0 \not\subset tL$ for any divisor $t (> 1)$ of N , we see that $(a, N) = 1$ and $N \mid b$. Then $\mathbb{Z}w_1 \oplus \mathbb{Z}(Nw_2)$ is a unique submodule of L of index N containing αL_0 , and therefore,

$$L_0 = \mathbb{Z}w_1 \oplus \mathbb{Z}(Nw_2).$$

Moreover if we put $l = a$ and $m = b/N$, then $\mathbb{Z}(lw_1) \oplus \mathbb{Z}(mw_2)$ is a unique submodule of L of index n containing αL_0 . Therefore we get

$$\alpha L = \mathbb{Z}(lw_1) \oplus \mathbb{Z}(mw_2).$$

We define two elements γ_1, γ_2 of $M_2(\mathbb{Z})$ by

$$(w_1, w_2) = \left(\begin{bmatrix} 1 \\ 0 \end{bmatrix}, \begin{bmatrix} 0 \\ 1 \end{bmatrix} \right) \gamma_1, \quad \left(\alpha \begin{bmatrix} 1 \\ 0 \end{bmatrix}, \alpha \begin{bmatrix} 0 \\ 1 \end{bmatrix} \right) = (lw_1, mw_2) \gamma_2.$$

Then

$$\alpha = \gamma_1 \begin{bmatrix} l & 0 \\ 0 & m \end{bmatrix} \gamma_2.$$

We may assume $\det(\gamma_1) = \det(\gamma_2) = 1$ by taking $-w_2$ in place of w_2 , if necessary.

Since $w_1 \in L_0$ and $\alpha \begin{bmatrix} 1 \\ 0 \end{bmatrix} \in \alpha L_0$, we see $\gamma_1, \gamma_2 \in \Gamma_0(N)$. Therefore we obtain

$$\Gamma_0(N) \alpha \Gamma_0(N) = \Gamma_0(N) \begin{bmatrix} l & 0 \\ 0 & m \end{bmatrix} \Gamma_0(N).$$

Since

$$(4.5.6) \quad L/\alpha L \simeq \mathbb{Z}/l\mathbb{Z} \oplus \mathbb{Z}/m\mathbb{Z},$$

the pair (l, m) is uniquely determined by the fundamental theorem of abelian groups. A similar argument is also applicable to $\Delta_0^*(N)$. \square

We note by (4.5.6),

$$(4.5.7) \quad \text{if } l \mid m \text{ and } (lm, N) = 1, \text{ then } \Gamma_0(N) \begin{bmatrix} l & 0 \\ 0 & m \end{bmatrix} \Gamma_0(N) = \Gamma_0(N) \begin{bmatrix} m & 0 \\ 0 & l \end{bmatrix} \Gamma_0(N).$$

Theorem 4.5.3. (1) Both Hecke algebras $\mathcal{R}(N)$ and $\mathcal{R}^*(N)$ are commutative.

(2) For any element $\Gamma_0(N) \alpha \Gamma_0(N)$ of $\mathcal{R}(N) \cup \mathcal{R}^*(N)$, both $\Gamma_0(N) \setminus \Gamma_0(N) \alpha \Gamma_0(N)$ and $\Gamma_0(N) \alpha \Gamma_0(N) / \Gamma_0(N)$ have a common set of representatives.

Proof. For an element $\alpha = \begin{bmatrix} a & b \\ cN & d \end{bmatrix} \in \Delta_0(N)$ (resp. $\Delta_0^*(N)$), we put

$$\alpha' = \begin{bmatrix} a & c \\ bN & d \end{bmatrix} \in \Delta_0(N) \quad (\text{resp. } \Delta_0^*(N)).$$

Then the correspondence “ $\alpha \mapsto \alpha'$ ” satisfies the three conditions of Theorem 2.7.8. In fact, conditions (i) and (ii) are obvious by definition, and (iii) is proved by Lemma 4.5.2 and (i). Therefore $\mathcal{R}(N)$ and $\mathcal{R}^*(N)$ are commutative. \square

Now let χ be a Dirichlet character mod N . We put

$$(4.5.8) \quad \chi(\alpha) = \overline{\chi(d)} \quad \text{for } \alpha = \begin{bmatrix} a & b \\ c & d \end{bmatrix} \in \Delta_0(N).$$

Then χ is an extension of the character of $\Gamma_0(N)$ defined by (4.3.2) to $\Delta_0(N)$. To let Hecke algebra $\mathcal{R}(N)$ act on $\mathcal{G}_k(N, \chi)$, we have to verify that χ satisfies (2.8.1), or

$$\text{if } \alpha\gamma\alpha^{-1} \in \Gamma_0(N) \quad (\gamma \in \Gamma_0(N), \alpha \in \Delta_0(N)) \quad \text{then } \chi(\alpha\gamma\alpha^{-1}) = \chi(\gamma).$$

In fact, by Lemma 4.5.2, we may assume $\alpha = \begin{bmatrix} l & 0 \\ 0 & m \end{bmatrix}$ ($l|m, (l, N) = 1$). Put $\gamma = \begin{bmatrix} a & b \\ cN & d \end{bmatrix} \in \Gamma_0(N)$, and $\gamma' = \alpha\gamma\alpha^{-1}$. If $\gamma' \in \Gamma_0(N)$, then $bl \equiv 0 \pmod m$ and

$$\gamma' = \begin{bmatrix} a & bl/m \\ cNm/l & d \end{bmatrix},$$

so that $\chi(\gamma) = \chi(\gamma')$. Therefore by Theorem 2.8.1, $\mathcal{R}(N)$ acts on $\mathcal{G}_k(N, \chi)$. More precisely, if

$$\Gamma_0(N)\alpha\Gamma_0(N) = \coprod_v \Gamma_0(N)\alpha_v$$

is an element of $\mathcal{R}(N)$, then

$$(4.5.9) \quad f | \Gamma_0(N)\alpha\Gamma_0(N) = \det(\alpha)^{k/2-1} \sum_v \overline{\chi(\alpha_v)} f |_{k\alpha_v} \quad (f \in \mathcal{G}_k(N, \chi)).$$

Next we extend the character χ of $\Gamma_0(N)$ to $\Delta_0^*(N)$ by

$$(4.5.10) \quad \chi^*(\alpha) = \chi(d) \quad \left(\alpha = \begin{bmatrix} a & b \\ c & d \end{bmatrix} \in \Delta_0^*(N) \right).$$

Similarly as above, this extension also satisfies (2.8.1), and $\mathcal{R}^*(N)$ also acts on $\mathcal{G}_k(N, \chi)$; namely, if $\Gamma_0(N)\alpha\Gamma_0(N) \in \mathcal{R}^*(N)$ and

$$\Gamma_0(N)\alpha\Gamma_0(N) = \coprod_v \Gamma_0(N)\alpha_v,$$

then

$$(4.5.11) \quad f | \Gamma_0(N)\alpha\Gamma_0(N) = \det(\alpha)^{k/2-1} \sum_v \overline{\chi^*(\alpha_v)} f |_{k\alpha_v} \quad (f \in \mathcal{G}_k(N, \chi)).$$

We note that when $\Gamma_0(N)\alpha\Gamma_0(N)$ is contained in $\mathcal{R}(N) \cap \mathcal{R}^*(N)$, the action of $\Gamma_0(N)\alpha\Gamma_0(N)$ as an element of $\mathcal{R}(N)$ does not necessarily coincide with the action as an element of $\mathcal{R}^*(N)$. The difference will be clarified in Theorem 4.5.4. We only note here that

$$(4.5.12) \quad \omega_N^{-1}\Gamma_0(N)\omega_N = \Gamma_0(N), \\ \Delta_0(N) \simeq \Delta_0^*(N) \quad \text{by} \quad " \alpha \mapsto \omega_N^{-1}\alpha\omega_N ",$$

and

$$(4.5.13) \quad \chi^*(\omega_N^{-1}\alpha\omega_N) = \overline{\chi(\alpha)} \quad (\alpha \in \Delta_0(N)).$$

We define the elements $T(n)$ and $T(l, m)$ of $\mathcal{R}(N)$ by

$$(4.5.14) \quad T(l, m) = \Gamma_0(N) \begin{bmatrix} l & 0 \\ 0 & m \end{bmatrix} \Gamma_0(N) \quad (l|m, (l, N) = 1),$$

$$T(n) = \sum_{\det(\alpha) = n} \Gamma_0(N)\alpha\Gamma_0(N),$$

where the summation is taken over all double cosets $\Gamma_0(N)\alpha\Gamma_0(N)$ in $\mathcal{R}(N)$ with $\det(\alpha) = n$. Similarly we put

$$(4.5.15) \quad T^*(m, l) = \Gamma_0(N) \begin{bmatrix} m & 0 \\ 0 & l \end{bmatrix} \Gamma_0(N) \quad (l|m, (l, N) = 1),$$

$$T^*(n) = \sum_{\det(\alpha) = n} \Gamma_0(N)\alpha\Gamma_0(N),$$

where the summation is taken over all double cosets $\Gamma_0(N)\alpha\Gamma_0(N)$ in $\mathcal{R}^*(N)$ with $\det(\alpha) = n$. When we emphasize the level N , we write

$${}^N T(n), \quad {}^N T(l, m), \quad {}^N T^*(n), \quad \text{and} \quad {}^N T^*(m, l),$$

respectively. Now Lemma 4.5.2 implies

$$(4.5.16) \quad T(n) = \sum_{lm=n} T(l, m),$$

$$T^*(n) = \sum_{lm=n} T^*(m, l),$$

and, in particular, for a prime number p we have

$$(4.5.17) \quad T(p) = T(1, p), \quad T^*(p) = T^*(p, 1).$$

Moreover, if $(n, N) = 1$, then

$$T(n, n) = \Gamma_0(N) \begin{bmatrix} n & 0 \\ 0 & n \end{bmatrix} \Gamma_0(N) = \Gamma_0(N) \begin{bmatrix} n & 0 \\ 0 & n \end{bmatrix},$$

so that

$$(4.5.18) \quad T(n, n)T(l, m) = T(nl, nm),$$

$$T^*(n, n)T^*(m, l) = T^*(nm, nl).$$

Theorem 4.5.4. (1) For any element $f(z)$ of $\mathcal{G}_k(N, \chi)$, we have

$$f|T^*(m, l) = \bar{\chi}(lm)(f|T(l, m)) \quad \text{if } (lm, N) = 1,$$

$$f|T^*(n) = \bar{\chi}(n)(f|T(n)) \quad \text{if } (n, N) = 1.$$

(2) $T(l, m)$ and $T^*(m, l)$ (resp. $T(n)$ and $T^*(n)$) are the mutual adjoint operators with respect to the Petersson inner product on $\mathcal{S}_k(N, \chi)$.

(3) $\mathcal{S}_k(N, \chi)$ has a basis consisting of common eigenfunctions of all $T(n)$ and $T(l, m)$ ($(n, N) = 1, (lm, N) = 1$).

Proof. (1): Assume $(lm, N) = 1$. Put

$$\Gamma_0(N) \begin{bmatrix} l & 0 \\ 0 & m \end{bmatrix} \Gamma_0(N) = \coprod_{\mathfrak{v}} \Gamma_0(N) \alpha_{\mathfrak{v}}.$$

By (4.5.7), we have

$$\Gamma_0(N) \begin{bmatrix} l & 0 \\ 0 & m \end{bmatrix} \Gamma_0(N) = \Gamma_0(N) \begin{bmatrix} m & 0 \\ 0 & l \end{bmatrix} \Gamma_0(N),$$

and

$$\chi^*(\alpha) = \chi(\det(\alpha))\chi(\alpha)$$

for any element α of $\Delta_0(N) \cap \Delta_0^*(N)$. Hence we see

$$f|T^*(m, l) = (lm)^{k/2-1} \sum_{\mathfrak{v}} \overline{\chi^*(\alpha_{\mathfrak{v}})}(f|_k \alpha_{\mathfrak{v}})$$

$$= \bar{\chi}(lm)(lm)^{k/2-1} \sum_{\mathfrak{v}} \overline{\chi(\alpha_{\mathfrak{v}})}(f|_k \alpha_{\mathfrak{v}})$$

$$= \bar{\chi}(lm)(f|T(l, m)).$$

Moreover, by (4.5.16) we get that $f|T^*(n) = \bar{\chi}(n)(f|T(n))$ if $(n, N) = 1$. (2): For an element $\alpha = \begin{bmatrix} a & b \\ c & d \end{bmatrix}$ of $GL_2^+(\mathbb{R})$, we put

$$\alpha' = \det(\alpha)\alpha^{-1} = \begin{bmatrix} d & -b \\ -c & a \end{bmatrix}.$$

The correspondence “ $\alpha \mapsto \alpha'$ ” is an anti-isomorphism of $\Delta_0(N)$ onto $\Delta_0^*(N)$. By Theorem 4.5.3(2), we can take a complete set of representatives $\{\alpha_{\mathfrak{v}}\}$ so that

$$(4.5.19) \quad \Gamma_0(N) \begin{bmatrix} l & 0 \\ 0 & m \end{bmatrix} \Gamma_0(N) = \coprod_{\mathfrak{v}} \Gamma_0(N) \alpha_{\mathfrak{v}} = \coprod_{\mathfrak{v}} \alpha_{\mathfrak{v}} \Gamma_0(N).$$

Then

$$\Gamma_0(N) \begin{bmatrix} m & 0 \\ 0 & l \end{bmatrix} \Gamma_0(N) = \coprod_{\mathfrak{v}} \Gamma_0(N) \alpha'_{\mathfrak{v}}.$$

Let T^* be the adjoint operator of $T(l, m)$ with respect to the Petersson inner product. Since $\chi(\alpha_{\mathfrak{v}}) = \overline{\chi^*(\alpha'_{\mathfrak{v}})}$, we see by Theorem 2.8.2(1)

$$\begin{aligned} (4.5.20) \quad f|T^* &= (lm)^{k/2-1} \sum_{\mathfrak{v}} \chi(\alpha_{\mathfrak{v}}) (f|_k \alpha'_{\mathfrak{v}}) \\ &= (lm)^{k/2-1} \sum_{\mathfrak{v}} \overline{\chi^*(\alpha'_{\mathfrak{v}})} (f|_k \alpha'_{\mathfrak{v}}) \\ &= f|T^*(m, l). \end{aligned}$$

Therefore $T(l, m)$ and $T^*(m, l)$ are adjoint to each other. By (4.5.16), so are $T(n)$ and $T^*(n)$. (3): By (1) and (2), if $(lm, N) = 1$, then $T(n)$ and $T(l, m)$ are normal operators on $\mathcal{S}_k(N, \chi)$. Since $\mathcal{R}(N)$ is commutative, they are simultaneously diagonalizable. \square

As was shown in Lemma 4.3.2, $\mathcal{G}_k(N, \chi)$ is isomorphic to $\mathcal{G}_k(N, \bar{\chi})$ by the correspondence “ $f \mapsto f|_k \omega_N$ ”.

Theorem 4.5.5. *The following diagram is commutative:*

$$\begin{array}{ccc} \mathcal{G}_k(N, \chi) & \xrightarrow{T(n) \text{ (resp. } T(l, m))} & \mathcal{G}_k(N, \chi) \\ \downarrow \omega_N & & \downarrow \omega_N \\ \mathcal{G}_k(N, \bar{\chi}) & \xrightarrow{T^*(n) \text{ (resp. } T^*(m, l))} & \mathcal{G}_k(N, \bar{\chi}). \end{array}$$

Proof. We have only to prove the theorem for $T(l, m)$. Put $\Gamma_0(N) \begin{bmatrix} l & 0 \\ 0 & m \end{bmatrix} \Gamma_0(N) = \coprod_{\mathfrak{v}} \Gamma_0(N) \alpha_{\mathfrak{v}}$. Then

$$\Gamma_0(N) \begin{bmatrix} m & 0 \\ 0 & l \end{bmatrix} \Gamma_0(N) = \coprod_{\mathfrak{v}} \Gamma_0(N) (\omega_N^{-1} \alpha_{\mathfrak{v}} \omega_N),$$

so that for an element $f(z)$ of $\mathcal{G}_k(N, \bar{\chi})$, we see by (4.5.13) that

$$\begin{aligned} f|_k \omega_N^{-1} T(l, m) \omega_N &= (lm)^{k/2-1} \sum_{\mathfrak{v}} \overline{\chi(\alpha_{\mathfrak{v}})} (f|_k \omega_N^{-1} \alpha_{\mathfrak{v}} \omega_N) \\ &= (lm)^{k/2-1} \sum_{\mathfrak{v}} \chi^*(\omega_N^{-1} \alpha_{\mathfrak{v}} \omega_N) (f|_k \omega_N^{-1} \alpha_{\mathfrak{v}} \omega_N) \\ &= f|T^*(m, l). \end{aligned} \quad \square$$

Lemma 4.5.6. *Let p be a prime number, and e a non-negative integer.*

(1) *As a complete set of representatives of*

$$\Gamma_0(N) \backslash \Gamma_0(N) \begin{bmatrix} 1 & 0 \\ 0 & p^e \end{bmatrix} \Gamma_0(N),$$

we may take the following set:

$$\left\{ \left\{ \begin{bmatrix} p^{e-f} & m \\ 0 & p^f \end{bmatrix} \mid 0 \leq f \leq e, \quad 0 \leq m < p^f, \quad (m, p^f, p^{e-f}) = 1 \right\} \text{ if } p \nmid N, \right.$$

$$\left. \left\{ \begin{bmatrix} 1 & m \\ 0 & p^e \end{bmatrix} \mid 0 \leq m < p^e \right\} \text{ if } p \mid N. \right.$$

$$(2) \deg(\Gamma_0(N) \begin{bmatrix} 1 & 0 \\ 0 & p^e \end{bmatrix} \Gamma_0(N)) = \begin{cases} p^e + p^{e-1} & \text{if } p \nmid N, \\ p^e & \text{if } p \mid N. \end{cases}$$

Proof. First we are going to prove that for any element $\beta = \begin{bmatrix} a & b \\ cN & d \end{bmatrix}$ of $\Gamma_0(N) \begin{bmatrix} 1 & 0 \\ 0 & p^e \end{bmatrix} \Gamma_0(N)$, there exists an element γ of $\Gamma_0(N)$ such that

$$\gamma\beta = \begin{bmatrix} p^{e-f} & m \\ 0 & p^f \end{bmatrix} \quad (0 \leq m < p^f).$$

In fact, since $\det(\beta) = p^e$, (a, cN) is a power of p . Suppose $p \mid N$. Since $(a, N) = 1$, we have $(a, cN) = 1$, so that there exists an element γ_1 of $\Gamma_0(N)$ such that

$$\gamma_1 = \begin{bmatrix} * & * \\ -cN & a \end{bmatrix}.$$

Then $\gamma_1\beta = \begin{bmatrix} 1 & n \\ 0 & p^e \end{bmatrix}$ with some n . Let

$$n = lp^e + m \quad (0 \leq m < p^e)$$

with integers l and m , and put

$$\gamma_2 = \begin{bmatrix} 1 & -l \\ 0 & 1 \end{bmatrix} \in \Gamma_0(N).$$

Then

$$\gamma_2\gamma_1\beta = \begin{bmatrix} 1 & m \\ 0 & p^e \end{bmatrix}.$$

Next assume $(p, N) = 1$. Put $a' = a/(a, cN)$ and $c' = c/(a, cN)$. Since $(a, N) = 1$, c' is integral and $(a', c'N) = 1$. Thus there exists an element γ_1 in $\Gamma_0(N)$ of the form

$$\gamma_1 = \begin{bmatrix} * & * \\ -c'N & a' \end{bmatrix}.$$

Then

$$\gamma_1\beta = \begin{bmatrix} p^{e-f} & n \\ 0 & p^f \end{bmatrix}$$

with integers f and n . Similarly as above, we can take an element γ_2 of $\Gamma_0(N)$ so that

$$\gamma_2 \gamma_1 \beta = \begin{bmatrix} p^{e-f} & m \\ 0 & p^f \end{bmatrix} \quad (0 \leq m < p^f).$$

Consequently we get

$$(4.5.21) \quad \Gamma_0(N) \begin{bmatrix} 1 & 0 \\ 0 & p^e \end{bmatrix} \Gamma_0(N) \subset \begin{cases} \bigcup_{m=0}^{p^e-1} \Gamma_0(N) \begin{bmatrix} 1 & m \\ 0 & p^e \end{bmatrix} & \text{if } p|N, \\ \bigcup_{f=0}^e \bigcup_{m=0}^{p^f-1} \Gamma_0(N) \begin{bmatrix} p^{e-f} & m \\ 0 & p^f \end{bmatrix} & \text{if } p \nmid N. \end{cases}$$

Next we are going to prove that the right-hand sides of (4.5.21) are disjoint unions. Suppose

$$\Gamma_0(N) \begin{bmatrix} p^{e-f} & m \\ 0 & p^f \end{bmatrix} \cap \Gamma_0(N) \begin{bmatrix} p^{e-g} & n \\ 0 & p^g \end{bmatrix} \neq \emptyset.$$

Then there exists an element γ of $\Gamma_0(N)$ such that

$$(4.5.22) \quad \gamma \begin{bmatrix} p^{e-f} & m \\ 0 & p^f \end{bmatrix} = \begin{bmatrix} p^{e-g} & n \\ 0 & p^g \end{bmatrix}.$$

An easy calculation shows that γ is of the form $\begin{bmatrix} 1 & * \\ 0 & 1 \end{bmatrix}$ which implies $f = g$ and $m = n$. This proves the disjointness of the right-hand sides. First assume $p|N$. Since

$$\begin{bmatrix} 1 & m \\ 0 & p^e \end{bmatrix} = \begin{bmatrix} 1 & 0 \\ 0 & p^e \end{bmatrix} \begin{bmatrix} 1 & m \\ 0 & 1 \end{bmatrix} \in \Gamma_0(N) \begin{bmatrix} 1 & 0 \\ 0 & p^e \end{bmatrix} \Gamma_0(N),$$

we get

$$\Gamma_0(N) \begin{bmatrix} 1 & 0 \\ 0 & p^e \end{bmatrix} \Gamma_0(N) = \prod_{m=0}^{p^e-1} \Gamma_0(N) \begin{bmatrix} 1 & m \\ 0 & p^e \end{bmatrix}.$$

Next assume $(p, N) = 1$. Put

$$\alpha = \begin{bmatrix} p^{e-f} & m \\ 0 & p^f \end{bmatrix}.$$

By Lemma 4.5.2, there exist two integers a, b ($0 \leq a \leq b, a + b = e$) such that

$$\Gamma_0(N) \alpha \Gamma_0(N) = \Gamma_0(N) \begin{bmatrix} p^a & 0 \\ 0 & p^b \end{bmatrix} \Gamma_0(N).$$

Put

$$\beta = \begin{bmatrix} p^a & 0 \\ 0 & p^b \end{bmatrix}$$

and

$$L = \left\{ \begin{bmatrix} u \\ v \end{bmatrix} \mid u, v \in \mathbb{Z} \right\}.$$

Since any element of $\Gamma_0(N)$ induces an automorphism of L , we have

$$L/\alpha L \simeq L/\beta L \simeq \mathbb{Z}/p^a \mathbb{Z} \oplus \mathbb{Z}/p^b \mathbb{Z}.$$

Therefore,

$$\Gamma_0(N)\alpha\Gamma_0(N) = \Gamma_0(N) \begin{bmatrix} 1 & 0 \\ 0 & p^e \end{bmatrix} \Gamma_0(N)$$

if and only if $\alpha L \not\subseteq pL$. This is equivalent to saying that $(p^f, p^{e-f}, m) = 1$. This concludes the proof of (1). The second assertion follows from (1). \square

Lemma 4.5.7. *Let p be a prime number, and e a positive integer. Then we have:*

$$(1) \quad T(p)T(1, p^e) = T(1, p^{e+1}) + \begin{cases} (p+1)T(p, p) & \text{if } p \nmid N \text{ and } e = 1, \\ pT(p, p)T(1, p^{e-1}) & \text{if } p \nmid N \text{ and } e > 1, \\ 0 & \text{if } p|N. \end{cases}$$

$$(2) \quad T(p)T(p^e) = \begin{cases} T(p^{e+1}) + pT(p, p)T(p^{e-1}) & \text{if } p \nmid N, \\ T(p^{e+1}) & \text{if } p|N. \end{cases}$$

Proof. Let $T = \Gamma_0(N)\alpha\Gamma_0(N)$ be a constituent of $T(p)T(1, p^e)$. By the definition of the multiplication, we can write

$$\alpha = \alpha_1\alpha_2 \quad (\alpha_1 \in T(p), \quad \alpha_2 \in T(1, p^e)).$$

Put

$$L = \left\{ \begin{bmatrix} u \\ v \end{bmatrix} \middle| u, v \in \mathbb{Z} \right\}.$$

Since $[L:\alpha L] = p^{e+1}$ and

$$L/\alpha L \supset \alpha_1 L/\alpha L \simeq L/\alpha_2 L \simeq \mathbb{Z}/p^e \mathbb{Z},$$

T coincides with $T(1, p^{e+1})$ or $T(p, p^e)$. Hence

$$T(p)T(1, p^e) = \begin{cases} aT(1, p^{e+1}) + bT(p, p^e) & \text{if } p \nmid N, \\ a'T(1, p^{e+1}) & \text{if } p|N, \end{cases}$$

with integers a, b and a' . By Lemma 4.5.6(1) and the definition of the multiplication, we get $a = a' = 1$. Comparing the degrees of both sides using Lemma 4.5.6(2) and (2.7.7), we obtain

$$b = \begin{cases} p+1 & \text{if } e = 1, \\ p & \text{if } e > 1. \end{cases}$$

This proves (1). When $p|N$, we see $T(p^e) = T(1, p^e)$, so that (2) is nothing but the first assertion. Now assume that $(p, N) = 1$. We prove the assertion by induction on e . First let $e = 1$. Since $T(p) = T(1, p)$, we see by (1) that

$$\begin{aligned} T(p)T(p) &= T(1, p^2) + (p+1)T(p, p) \\ &= T(p^2) + pT(p, p). \end{aligned}$$

Next assume $e \geq 2$ and the assertion is true for all positive integers less than e . Applying (4.5.16) and (4.5.18) to $T(p^e)$, we see

$$\begin{aligned} T(p)T(p^e) &= T(p) \{ T(1, p^e) + T(p, p)T(p^{e-2}) \} \\ &= T(1, p^{e+1}) + pT(p, p)T(1, p^{e-1}) + T(p, p)T(p)T(p^{e-2}) \\ &= T(1, p^{e+1}) + pT(p, p)T(1, p^{e-1}) \\ &\quad + T(p, p) \{ T(p^{e-1}) + pT(p, p)T(p^{e-3}) \} \\ &= T(1, p^{e+1}) + T(p, p)T(1, p^{e-1}) \\ &\quad + pT(p, p) \{ T(1, p^{e-1}) + T(p, p)T(p^{e-3}) \} \\ &= T(p^{e+1}) + pT(p, p)T(p^{e-1}). \end{aligned}$$

Here we understand $T(p^e) = 0$ if $e < 0$. This is what we wanted to show. □

Lemma 4.5.8. (1) If $(lm, l'm') = 1$, then

$$T(l, m)T(l', m') = T(ll', mm').$$

(2) If $(m, n) = 1$, then $T(m)T(n) = T(mn)$.

Proof. (1): Let $T = \Gamma_0(N)\alpha\Gamma_0(N)$ be any constituent of $T(l, m)T(l', m')$, then we can write $\alpha = \alpha_1\alpha_2$ with $\alpha_1 \in T(l, m)$, $\alpha_2 \in T(l', m')$. Put

$$L = \left\{ \begin{bmatrix} u \\ v \end{bmatrix} \mid u, v \in \mathbb{Z} \right\},$$

then

$$\begin{aligned} L/\alpha_1 L &\simeq \mathbb{Z}/l\mathbb{Z} \oplus \mathbb{Z}/m\mathbb{Z}, \\ \alpha_1 L/\alpha_2 L &\simeq L/\alpha_2 L \simeq \mathbb{Z}/l'\mathbb{Z} \oplus \mathbb{Z}/m'\mathbb{Z}. \end{aligned}$$

Since $(lm, l'm') = 1$, we get

$$L/\alpha L \simeq \mathbb{Z}/ll'\mathbb{Z} \oplus \mathbb{Z}/mm'\mathbb{Z},$$

namely $T = T(ll', mm')$. Therefore $T(l, m)T(l', m') = aT(ll', mm')$ with some integer a . We are going to prove $a = 1$. Let

$$\alpha = \begin{bmatrix} ll' & 0 \\ 0 & mm' \end{bmatrix},$$

$$\Gamma_0(N) \begin{bmatrix} l & 0 \\ 0 & m \end{bmatrix} \Gamma_0(N) = \coprod_{\mu} \Gamma_0(N) \alpha_{\mu},$$

and

$$\Gamma_0(N) \begin{bmatrix} l' & 0 \\ 0 & m' \end{bmatrix} \Gamma_0(N) = \coprod_{\nu} \Gamma_0(N) \beta_{\nu}.$$

We may assume

$$\alpha_1 = \begin{bmatrix} l & 0 \\ 0 & m \end{bmatrix}, \quad \beta_1 = \begin{bmatrix} l' & 0 \\ 0 & m' \end{bmatrix}.$$

Now we assume $\Gamma_0(N)\alpha = \Gamma_0(N)\alpha_\mu\beta_\nu$, and let $\alpha = \gamma\alpha_\mu\beta_\nu$ with $\gamma \in \Gamma_0(N)$. Put

$$M = \{[u, v] \mid u, v \in \mathbb{Z}\}$$

and define the submodule M_0 of M by

$$M_0 = \{[Nu, v] \mid u, v \in \mathbb{Z}\}.$$

We let $M_2(\mathbb{Z})$ act on M by the right multiplication of matrices. Then

$$(M\beta_1 + M\beta_\nu)/M\beta_1 \simeq M\beta_\nu/(M\beta_1 \cap M\beta_\nu).$$

Since the left-hand side is a subgroup of $M/M\beta_1$, the order is a divisor of $\det(\beta_1) = l'm'$. On the other hand, the right-hand side is the quotient group of $M\beta_\nu/M\alpha$; hence the order is a divisor of $\det(\alpha)/\det(\beta_\nu) = lm$. Since $(lm, l'm') = 1$, we get $M\beta_1 = M\beta_\nu$. Therefore there exists an element $\gamma_1 \in GL_2(\mathbb{Z})$ such that $\gamma_1\beta_1 = \beta_\nu$. Since $\det(\beta_1) = \det(\beta_\nu)$, we get $\gamma_1 \in SL_2(\mathbb{Z})$. A similar argument for M_0 in place of M implies $M_0\beta_1 = M_0\beta_\nu$, so that $M_0\gamma_1 = M_0$, namely $\gamma_1 \in \Gamma_0(N)$. Since β_ν is a representative of left $\Gamma_0(N)$ -cosets, we get $\gamma_1 = 1$ and $\beta_\nu = \beta_1$. Similarly we obtain $\alpha_\mu = \alpha_1$. Consequently $a = 1$. The second assertion easily follows from (1). □

Theorem 4.5.9. *The Hecke algebra $\mathcal{R}(N)$ is the polynomial ring over \mathbb{Z} generated by $T(p)$, $T(p, p)$ with all prime numbers p prime to N , and $T(q)$ with prime numbers q dividing N ; namely,*

$$\mathcal{R}(N) = \mathbb{Z}[T(p), T(p, p), T(q) \mid p \nmid N, q \mid N].$$

Proof. By Theorem 4.5.3, Lemma 4.5.7 and Lemma 4.5.8, $\mathcal{R}(N)$ is commutative and any element of $\mathcal{R}(N)$ can be expressed as a polynomial with rational integral coefficients in $T(p)$, $T(p, p)$ and $T(q)$. Moreover it can be easily verified by Lemma 4.5.7 and Lemma 4.5.8 that $T(p)$, $T(p, p)$ and $T(q)$ are algebraically independent over \mathbb{Q} . □

Take two positive integers l, m so that $l \mid m$ and $(l, N) = 1$. Let $m/l = \prod_p p^e$ be the prime decomposition. By Lemma 4.5.8, we see

$$(4.5.23) \quad T(l, m) = T(l, l)T(1, m/l) = T(l, l) \prod_p T(1, p^e),$$

where p is taken over prime divisors of m/l , so that we obtain

$$(4.5.24) \quad T(l, m) = \prod \Gamma_0(N) \begin{bmatrix} a & b \\ 0 & d \end{bmatrix} \quad (ad = lm, 0 \leq b < d, (a, b, d) = 1),$$

$$(4.5.25) \quad T(n) = \prod \Gamma_0(N) \begin{bmatrix} a & b \\ 0 & d \end{bmatrix} \quad (ad = n, 0 \leq b < d, (a, N) = 1),$$

by Lemma 4.5.6. Therefore we can express the action of $T(l, m)$ and $T(n)$ on $\mathcal{G}_k(N, \chi)$ explicitly. In particular, for $f(z) \in \mathcal{G}_k(N, \chi)$,

$$(4.5.26) \quad (f \mid T(n))(z) = n^{k-1} \sum_{\substack{0 < d \mid n \\ ad = n}} \sum_{b=0}^{d-1} \chi(a) d^{-k} f((az + b)/d),$$

and

$$(4.5.27) \quad (f|T(l, l))(z) = l^{k-2}\chi(l)f(z) \quad \text{if } (l, N) = 1.$$

We note that if $(a, N) \neq 1$, then $\chi(a) = 0$. For a positive integer n , we write $n|N^\infty$ if all prime factors of n divide N . We get the following relations between Hecke operators of modular groups of different levels.

Theorem 4.5.10. *Let M be a multiple of N , and n a positive integer. If $n|N^\infty$ or $(n, M) = 1$, then the following diagram is commutative:*

$$\begin{array}{ccc} \mathcal{G}_k(N, \chi) & \xrightarrow{N T(n) \text{ (resp. } N T^*(n))} & \mathcal{G}_k(N, \chi) \\ \downarrow & & \downarrow \\ \mathcal{G}_k(M, \chi) & \xrightarrow{M T(n) \text{ (resp. } M T^*(n))} & \mathcal{G}_k(M, \chi) \end{array}$$

Here χ is a Dirichlet character mod N and the vertical arrows indicate the natural embeddings.

Now we are going to study relations between the Hecke algebras of modular groups of different levels as a preparation for the next section. Let χ be a Dirichlet character mod N , and M a multiple of N . If $\alpha \in \Delta_0(N)$, then

$$\Gamma_0(M)\alpha\Gamma_0(N) \subset \Delta_0(N).$$

Therefore an element of $\mathcal{R}(\Gamma_0(M), \Gamma_0(N); \Delta_0(N))$ induces a linear mapping of $\mathcal{G}_k(M, \chi)$ into $\mathcal{G}_k(N, \chi)$ by Lemma 2.7.2(2). We shall use the following lemma in §4.6.

Lemma 4.5.11. *For a positive integer N and a prime number p , we have*

$$\Gamma_0(pN) \begin{bmatrix} 1 & 0 \\ 0 & p \end{bmatrix} \Gamma_0(N) = \begin{cases} \prod_{v=0}^{p-1} \Gamma_0(pN) \begin{bmatrix} 1 & 0 \\ 0 & p \end{bmatrix} \gamma_v & \text{if } p|N, \\ \prod_{v=0}^p \Gamma_0(pN) \begin{bmatrix} 1 & 0 \\ 0 & p \end{bmatrix} \gamma_v & \text{if } p \nmid N. \end{cases}$$

Here γ_v ($0 \leq v < p$) is an element of $\Gamma_0(N)$ such that

$$\gamma_v \equiv \begin{bmatrix} 1 & v \\ 0 & 1 \end{bmatrix} \pmod{p},$$

and γ_p ($p \nmid N$) is an element of $\Gamma_0(N)$ such that

$$\gamma_p \equiv \begin{cases} \begin{bmatrix} 0 & -a \\ a^{-1} & 0 \end{bmatrix} \pmod{p}, & \text{with an integer } a \text{ prime to } p, \\ \begin{bmatrix} 1 & 0 \\ 0 & 1 \end{bmatrix} \pmod{N}. \end{cases}$$

Proof. Put

$$(4.5.28) \quad \begin{aligned} \Gamma' &= \Gamma_0(N) \cap \begin{bmatrix} 1 & 0 \\ 0 & p \end{bmatrix}^{-1} \Gamma_0(pN) \begin{bmatrix} 1 & 0 \\ 0 & p \end{bmatrix} \\ &= \left\{ \begin{bmatrix} a & b \\ c & d \end{bmatrix} \in \Gamma_0(N) \mid b \equiv 0 \pmod{p} \right\}. \end{aligned}$$

By Lemma 2.7.1(4), we have only to get representatives of $\Gamma' \backslash \Gamma_0(N)$. First suppose $(p, N) = 1$. Since

$$\Gamma_0(N) \supset \Gamma' \supset \Gamma(pN),$$

$\Gamma' \backslash \Gamma_0(N)$ corresponds bijectively to $\lambda_{pN}(\Gamma') \backslash \lambda_{pN}(\Gamma_0(N))$ where λ_{pN} is the homomorphism of $SL_2(\mathbb{Z})$ onto $SL_2(\mathbb{Z}/pN\mathbb{Z})$ defined in §4.2. Through the isomorphism

$$SL_2(\mathbb{Z}/pN\mathbb{Z}) \simeq SL_2(\mathbb{Z}/p\mathbb{Z}) \times SL_2(\mathbb{Z}/N\mathbb{Z}),$$

$\lambda_{pN}(\Gamma')$ corresponds to $\lambda_p(\Gamma') \times \lambda_N(\Gamma')$, and so does $\lambda_{pN}(\Gamma_0(N))$ to $\lambda_p(\Gamma_0(N)) \times \lambda_N(\Gamma_0(N))$. Consequently $\Gamma' \backslash \Gamma_0(N)$ corresponds bijectively to

$$\lambda_p(\Gamma') \backslash \lambda_p(\Gamma_0(N)) \times \lambda_N(\Gamma') \backslash \lambda_N(\Gamma_0(N)).$$

It can be easily verified that

$$\lambda_N(\Gamma') = \lambda_N(\Gamma_0(N)),$$

so that $\Gamma' \backslash \Gamma_0(N)$ corresponds to $\lambda_p(\Gamma') \backslash \lambda_p(\Gamma_0(N))$. Since

$$\begin{aligned} \lambda_p(\Gamma_0(N)) &= SL_2(\mathbb{Z}/p\mathbb{Z}), \\ \lambda_p(\Gamma') &= \left\{ \begin{bmatrix} a & b \\ c & d \end{bmatrix} \in SL_2(\mathbb{Z}/p\mathbb{Z}) \mid b \equiv 0 \pmod{p} \right\}, \end{aligned}$$

we get

$$\lambda_p(\Gamma_0(N)) = \prod_{v=0}^{p-1} \lambda_p(\Gamma') \alpha_v,$$

where α_v are the elements of $\lambda_p(\Gamma_0(N))$ defined by

$$\alpha_v = \begin{cases} \begin{bmatrix} 1 & \bar{v} \\ 0 & 1 \end{bmatrix} & (0 \leq v \leq p-1), \\ \begin{bmatrix} 0 & -\bar{a} \\ \bar{a}^{-1} & 0 \end{bmatrix} & (v = p), \end{cases}$$

and $\bar{v} = v \pmod{p}$, \bar{a} is an element of $(\mathbb{Z}/p\mathbb{Z})^\times$. Since $\lambda_p(\gamma_v) = \alpha_v$, we obtain

$$\Gamma_0(N) = \prod_{v=0}^{p-1} \Gamma' \gamma_v.$$

Next assume that $p|N$. Then a direct calculation proves

$$\Gamma_0(N) = \prod_{v=0}^{p-1} \Gamma' \gamma_v. \quad \square$$

Hecke operators of modular groups have an important property that their eigenvalues coincide with Fourier coefficients of modular forms at ∞ . It can be shown from this fact that if a modular form $f(z)$ is a common eigenfunction of Hecke operators, then the associated Dirichlet series $L(s; f)$ has an Euler product. Before we explain this fact precisely, we state a general lemma.

Lemma 4.5.12. *Let K be a commutative ring with unity. Assume that two sequences $\{t(n)\}_{n=1}^\infty$ and $\{d(n)\}_{n=1}^\infty$ of elements of K satisfy the two conditions:*

- (i) $t(1) = d(1) = 1$;
- (ii) $d(mn) = d(m)d(n)$ for any positive integers m and n .

Then the following three conditions are equivalent.

- (1) *If $(m, n) = 1$, then $t(mn) = t(m)t(n)$, and*

$$t(p)t(p^e) = t(p^{e+1}) + pd(p)t(p^{e-1})$$

for all prime numbers p and all positive integers e .

- (2) *The formal Dirichlet series $\sum_{n=1}^\infty t(n)n^{-s}$ has the formal Euler product*

$$\sum_{n=1}^\infty t(n)n^{-s} = \prod_p (1 - t(p)p^{-s} + pd(p)p^{-2s})^{-1}.$$

- (3) *For any positive integers m and n ,*

$$t(m)t(n) = \sum_{0 < l|(m, n)} ld(l)t(mn/l^2).$$

Proof. (1) \Rightarrow (2): By the first condition of (1), we can write formally

$$(4.5.29) \quad \sum_{n=1}^\infty t(n)n^{-s} = \prod_p \left(\sum_{e=0}^\infty t(p^e)p^{-es} \right).$$

Since

$$(1 - t(p)p^{-s} + pd(p)p^{-2s}) \left(\sum_{e=0}^\infty t(p^e)p^{-es} \right) = 1$$

by the second condition of (1), we obtain (2).

(2) \Rightarrow (3): It is obvious that if $(m, n) = 1$, then $t(mn) = t(m)t(n)$. Let $m = \prod_p p^e$ and $n = \prod_p p^f$ be the expressions as powers of prime numbers. Then

$$\sum_{0 < l|(m, n)} ld(l)t(mn/l^2) = \prod_p \left(\sum_{0 \leq g \leq \min\{e, f\}} p^g d(p^g)t(p^{e+f-2g}) \right).$$

Therefore we have only to prove (3) when m and n are powers of a prime p . By the assumption of (2), we have

$$(4.5.30) \quad \sum_{e=0}^\infty t(p^e)p^{-es} = (1 - t(p)p^{-s} + pd(p)p^{-2s})^{-1}.$$

Let $t'(p)$ and $d'(p)$ be two variables over \mathbb{Q} , and

$$\psi: \mathbb{Z}[t'(p), d'(p)] \rightarrow K$$

the ring homomorphism defined by

$$(4.5.31) \quad \psi(1) = 1, \quad \psi(t'(p)) = t(p), \quad \text{and} \quad \psi(d'(p)) = d(p).$$

We define the elements $t'(p^e)$ and $d'(p^e)$ of $\mathbb{Z}[t'(p), d'(p)]$ by

$$(4.5.32) \quad d'(p^e) = d'(p)^e$$

and the formal power series

$$(4.5.33) \quad \sum_{e=0}^{\infty} t'(p^e)p^{-es} = (1 - t'(p)p^{-s} + pd'(p)p^{-2s})^{-1}.$$

Then by (4.5.30) through (4.5.33), we have

$$(4.5.34) \quad \psi(t'(p^e)) = t(p^e) \quad \text{and} \quad \psi(d'(p^e)) = d(p^e).$$

Let u and v be two variables over \mathbb{Q} , and

$$\phi: \mathbb{Z}[t'(p), d'(p)] \rightarrow \mathbb{Q}[u, v]$$

be the ring homomorphism defined by

$$\phi(t'(p)) = u + v \quad \text{and} \quad \phi(d'(p)) = \frac{1}{p}uv.$$

Since $u + v$ and uv/p are algebraically independent over \mathbb{Q} , ϕ is injective. Considering $\mathbb{Z}[t'(p), d'(p)]$ as a subring of $\mathbb{Q}[u, v]$, we have

$$1 - t'(p)p^{-s} + pd'(p)p^{-2s} = (1 - up^{-s})(1 - vp^{-s}).$$

Therefore by (4.5.33), we have

$$(4.5.35) \quad \begin{aligned} t'(p^e) &= (u^{e+1} - v^{e+1})/(u - v) \\ &= \sum_{i+j=e} u^i v^j. \end{aligned}$$

Assume $e \leq f$. Then we see

$$\begin{aligned} t'(p^e)t'(p^f) &= \left(\sum_{i+j=e} u^i v^j \right) \cdot (u^{f+1} - v^{f+1})/(u - v) \\ &= \left(u^{f+1} \sum_{j=0}^e u^{-j} v^j - v^{f+1} \sum_{j=0}^e u^j v^{e-j} \right) / (u - v) \\ &= \sum_{g=0}^e u^g v^g (u^{e+f-2g+1} - v^{e+f-2g+1}) / (u - v) \\ &= \sum_{g=0}^e p^g d'(p^g) t'(p^{e+f-2g}). \end{aligned}$$

Applying ψ to both sides, we see by (4.5.34)

$$t(p^e)t(p^f) = \sum_{g=0}^e p^g d(p^g) t(p^{e+f-2g}),$$

and we have proved (3) for $m = p^e$ and $n = p^f$.

(3) \Rightarrow (1): This is obvious since (1) is a special case of (3). □

Applying the lemma for

$$K = \mathcal{R}(N),$$

$$t(n) = T(n),$$

and

$$d(n) = \begin{cases} T(n, n) & \text{if } (n, N) = 1, \\ 0 & \text{if } (n, N) \neq 1, \end{cases}$$

we obtain by Lemma 4.5.7(2) and Lemma 4.5.8(2) the following

Theorem 4.5.13. (1)

$$T(m)T(n) = \sum_{\substack{0 < l \mid (m, n) \\ (l, N) = 1}} lT(l, l)T(mn/l^2).$$

(2) *The formal Dirichlet series $\sum_{n=1}^{\infty} T(n)n^{-s}$ has the formal Euler product*

$$\sum_{n=1}^{\infty} T(n)n^{-s} = \prod_{p \nmid N} (1 - T(p)p^{-s} + T(p, p)p^{1-2s})^{-1} \times \prod_{p \mid N} (1 - T(p)p^{-s})^{-1}.$$

Now we study the relation between Fourier coefficients of modular forms $f(z)$ and those of $(f|T(n))(z)$.

Lemma 4.5.14. *Let $f(z)$ be an element of $\mathcal{G}_k(N, \chi)$, and*

$$f(z) = \sum_{n=0}^{\infty} c(n)e^{2\pi inz},$$

$$(f|T(m))(z) = \sum_{n=0}^{\infty} b(n)e^{2\pi inz}$$

be the Fourier expansions. Then

$$b(n) = \sum_{0 < d \mid (m, n)} \chi(d)d^{k-1}c(mn/d^2).$$

Proof. We note that

$$f((az + b)/d) = \sum_{n=0}^{\infty} c(n)e^{2\pi in(az + b)/d}.$$

Then by (4.5.26) and the equality

$$\sum_{b=0}^{d-1} e^{2\pi inb/d} = \begin{cases} d & \text{if } d \mid n \\ 0 & \text{if } d \nmid n, \end{cases}$$

we get

$$(4.5.36) \quad b(n) = \sum_{0 < a \mid (m, n)} \chi(a)a^{k-1}c(dn/a).$$

Since $ad = m$, we have $c(dn/a) = c(mn/a^2)$, so that we obtain the result. □

Lemma 4.5.15. *Let $f(z) = \sum_{n=0}^{\infty} c(n)e^{2\pi inz}$ be an element of $\mathcal{G}_k(N, \chi)$, and \mathbf{M} a set of prime numbers p satisfying*

$$f|T(p) = t(p)f \quad (t(p) \in \mathbb{C}).$$

Then we have:

(1) *If all prime factors of a positive integer m belong to \mathbf{M} , then $f(z)$ is an eigenfunction of $T(m)$. Moreover put*

$$f|T(m) = t(m)f \quad (t(m) \in \mathbb{C}),$$

then

$$c(m) = t(m)c(1).$$

$$(2) L(s; f) = \prod_{p \in \mathbf{M}} (1 - t(p)p^{-s} + \chi(p)p^{k-1-2s})^{-1} \times \sum'_n c(n)n^{-s},$$

where the summation \sum' is taken over all positive integers prime to all elements of \mathbf{M} .

Proof. The first half of (1) is obvious. Let n be a positive integer prime to m . Comparing the n -th Fourier coefficients of $f|T(m)$ and $t(m)f$, we obtain

$$(4.5.37) \quad t(m)c(n) = c(mn)$$

by Lemma 4.5.14. In particular, taking $n = 1$, we obtain the latter half of (1). By (4.5.37), we get formally

$$(4.5.38) \quad L(s; f) = \left(\sum''_m t(m)m^{-s} \right) \times \left(\sum'_n c(n)n^{-s} \right),$$

where the summation \sum'' is taken over 1 and the positive integers whose prime factors are all contained in \mathbf{M} , and \sum' is taken over the positive integers prime to all primes in \mathbf{M} . By Theorem 4.5.13(1),

$$t(n)t(m) = \sum_{\substack{0 < l|(m, n) \\ (l, N) = 1}} \chi(l)l^{k-1}t(mn/l^2)$$

for two integers m, n contained in \sum'' , so that we get at least formally

$$(4.5.39) \quad \sum''_m t(m)m^{-s} = \prod_{p \in \mathbf{M}} (1 - t(p)p^{-s} + \chi(p)p^{k-1-2s})^{-1}$$

by a similar argument as in Lemma 4.5.12. Furthermore if

$$(4.5.40) \quad c(n) = O(n^\alpha)$$

for some α , then (4.5.39) holds on $\text{Re}(s) > \alpha + 1$. In fact, if $f(z)$ is a cusp form, then (4.5.40) was proved in Corollary 2.1.6 with $\alpha = k/2$. If $f(z)$ is not a cusp form, then we shall see (4.5.40) in §4.7. □

By Theorem 4.5.4, the Hecke operators $T(n)$ ($(n, N) = 1$) are simultaneously diagonalizable on $\mathcal{S}_k(N, \chi)$. If an element $f(z) \in \mathcal{S}_k(N, \chi)$ is a common eigenfunction of Hecke operators $T(n)$ ($(n, N) = 1$), we can write by the above lemma

$$L(s; f) = \prod_{p \nmid N} (1 - t(p)p^{-s} + \chi(p)p^{k-1-2s})^{-1} \times \sum'_n c(n)n^{-s},$$

where the summation \sum' is taken over 1 and the positive integers whose prime factors are all divisors of N . Moreover if $f(z)$ is a common eigenfunction of all Hecke operators $T(n)$, we can take as \mathbf{M} the set of all prime numbers. In this case, we get the following

Theorem 4.5.16. *Let $f(z) = \sum_{n=0}^{\infty} c(n)e^{2\pi inz}$ be a nonzero element of $\mathcal{G}_k(N, \chi)$. The following conditions are equivalent:*

- (1) $f(z)$ is a common eigenfunction of all Hecke operators $T(n)$;
- (2) $c(1) \neq 0$ and

$$L(s; f) = c(1) \prod_p (1 - t(p)p^{-s} + \chi(p)p^{k-1-2s})^{-1},$$

where p runs over all prime numbers.

Moreover if $f(z)$ satisfies the above conditions, then

$$f|T(n) = t(n)f, \quad t(n) = c(n)/c(1)$$

for all $n \geq 1$.

Proof. (1) \Rightarrow (2): Let $f|T(n) = t(n)f$. By Lemma 4.5.15, we have $c(n) = t(n)c(1)$ for $n \geq 1$. Then if $c(1) = 0$, then $f(z) = c(0)$. Since $k \geq 1$, we get $f(z) = 0$; which contradicts the assumption. Therefore $c(1) \neq 0$. The latter half follows from Lemma 4.5.15(2). (2) \Rightarrow (1): Put $t(n) = c(n)/c(1)$ for positive integers n . Then we see

$$\sum_{n=1}^{\infty} t(n)n^{-s} = \prod_p (1 - t(p)p^{-s} + \chi(p)p^{k-1-2s})^{-1}.$$

By Lemma 4.5.12,

$$t(m)t(n) = \sum_{0 < d|(m,n)} d^{k-1} \chi(d) t(mn/d^2).$$

Multiplying both sides by $c(1)$, we get

$$t(m)c(n) = \sum_{0 < d|(m,n)} d^{k-1} \chi(d) c(mn/d^2).$$

The right-hand side is equal to the n -th Fourier coefficient of $f|T(m)$ by Lemma 4.5.14. Let $b(0)$ be the constant term of the Fourier expansion of $f|T(m)$, then

$$(f|T(m))(z) - t(m)f(z) = b(0) - c(0).$$

Since $f|T(m) - t(m)f$ is an element of $\mathcal{G}_k(N, \chi)$ and $k \geq 1$, we get $b(0) = c(0)$. Thus

$$f|T(m) = t(m)f. \quad \square$$

Let us consider the case when $N = 1$ and $k = 12$. Since $\dim \mathcal{S}_{12}(\Gamma(1)) = 1$, $\Delta(z)$ is a common eigenfunction of all Hecke operators $T(n)$. Hence, if we let

$$\Delta(z) = \sum_{n=1}^{\infty} \tau_n e^{2\pi inz}$$

be the Fourier expansion, then we obtain

$$\Delta | T(n) = \tau_n \Delta$$

and

$$L(s; \Delta(z)) = \prod_p (1 - \tau_p p^{-s} + p^{11-2s})^{-1}$$

since $\tau_1 = 1$. Ramanujan conjectured by calculating the Fourier coefficients of $\Delta(z)$ that $L(s; \Delta(z))$ has the Euler product as above, and further

$$|\tau_p| \leq 2p^{1/2},$$

which is the famous Ramanujan conjecture. Petersson generalized it as follows.

Theorem 4.5.17. (The Ramanujan–Petersson conjecture) *Let*

$$f(z) = \sum_{n=1}^{\infty} a(n)e^{2\pi inz}$$

be an element of $\mathcal{S}_k(N, \chi)$. If $(n, N) = 1$, then

$$a(n) = O(n^{(k-1)/2}).$$

We do not prove this theorem in this book. We only remark here that Theorem 4.5.17 is equivalent to saying that

(4.5.41) *if a prime number p does not divide N , then the absolute values of roots of the equation*

$$X^2 - t(p)X + \chi(p)p^{k-1} = 0$$

are $p^{(k-1)/2}$, where $t(p)$ is an eigenvalue of $T(p)$ on $\mathcal{S}_k(N, \chi)$.

It is easy to see Theorem 4.5.17 from (4.5.41). Conversely, let u and v be solutions of the equation

$$X^2 - t(p)X + \chi(p)p^{k-1} = 0,$$

then

$$t(p^e) = (u^{e+1} - v^{e+1})/(u - v), \quad |uv| = p^{k-1}.$$

Therefore Theorem 4.5.17 implies $|u| = |v| = p^{(k-1)/2}$.

The generalized Ramanujan conjecture for $k = 2$ was proved by [Eichler 2], [Shimura 2] and [Igusa]. They solved it as follows. If Γ is a principal congruence modular group, then \mathfrak{R}_Γ can be considered as an algebraic curve defined over \mathbb{Q} . By the congruence relation of Eichler–Shimura, it can be proved that the Hasse zeta-function of the algebraic curve \mathfrak{R}_Γ is essentially the product of $L(s; f)$ ($f \in \mathcal{S}_k(\Gamma)$). This reduces the Ramanujan conjecture to the Weil conjecture for congruence zeta-functions of algebraic curves defined over finite fields, which have been proved by Weil. Furthermore, this relation between Hasse zeta-functions and $L(s; f)$ implies that the Hasse zeta-function of \mathfrak{R}_Γ satisfies a certain functional equation. If $k > 2$, then the conjecture is reduced to the Weil conjecture for congruence zeta-functions of higher dimensional algebraic varieties, which was proved by [Deligne 2]. In the case when $k = 1$, [Deligne–Serre] solved the problem by proving that the Dirichlet

series is nothing but the Artin L -function with respect to a representation of degree 2 of the Galois group of a certain extension over \mathbb{Q} .

Now as we explained in the beginning of §4.3, the investigation of modular forms is reduced to that of $\mathcal{G}_k(N, \chi)$. However, sometimes it is necessary to consider $\mathcal{G}_k(\Gamma_1(N))$ and the Hecke operators acting on it. We shall study the Hecke algebra of $\Gamma_1(N)$ and the relation with the Hecke algebra for $\Gamma_0(N)$. Put

$$\Delta_1(N) = \left\{ \begin{bmatrix} a & b \\ c & d \end{bmatrix} \in M_2(\mathbb{Z}) \mid a \equiv 1, \quad c \equiv 0 \pmod{N}, \quad ad - bc > 0 \right\},$$

which is a subsemigroup of $GL_2(\mathbb{Q})$ containing $\Gamma_1(N)$.

Theorem 4.5.18. (1) $\mathcal{R}(\Gamma_1(N), \Delta_1(N))$ is isomorphic to $\mathcal{R}(\Gamma_0(N), \Delta_0(N))$ through the correspondence:

$$\Gamma_1(N)\alpha\Gamma_1(N) \mapsto \Gamma_0(N)\alpha\Gamma_0(N) \quad (\alpha \in \Delta_1(N)).$$

(2) The correspondence defined in (1) is commutative with the natural embedding of $\mathcal{G}_k(N, \chi)$ into $\mathcal{G}_k(\Gamma_1(N))$; namely, for any element α of $\Delta_1(N)$, the following diagram is commutative:

$$\begin{array}{ccc} \mathcal{G}_k(N, \chi) & \xrightarrow{\Gamma_0(N)\alpha\Gamma_0(N)} & \mathcal{G}_k(N, \chi) \\ \downarrow & & \downarrow \\ \mathcal{G}_k(\Gamma_1(N)) & \xrightarrow{\Gamma_1(N)\alpha\Gamma_1(N)} & \mathcal{G}_k(\Gamma_1(N)). \end{array}$$

Proof. We apply Theorem 2.7.6, taking $\Gamma_1(N), \Delta_1(N), \Gamma_0(N)$ and $\Delta_0(N)$ for Γ, Δ, D and D , respectively. We shall verify the three conditions there. Since conditions (i) and (iii) are satisfied obviously, we have only to prove the second condition, that is,

$$(4.5.42) \quad \Gamma_0(N)\alpha\Gamma_0(N) = \Gamma_0(N)\alpha\Gamma_1(N) \quad (\alpha \in \Delta_1(N)).$$

First we prove (4.5.42) is satisfied for any element $\alpha = \begin{bmatrix} l & 0 \\ 0 & m \end{bmatrix}$. Put $n = lm$, then as was mentioned after Corollary 4.2.2, we can choose a complete set of representatives of $\Gamma_0(N)/\Gamma_1(N)$ consisting of the elements γ such that

$$\gamma \equiv \begin{bmatrix} u & 0 \\ 0 & v \end{bmatrix} \pmod{nN}.$$

Then $\alpha^{-1}\gamma\alpha \in SL_2(\mathbb{Z})$ and

$$\alpha^{-1}\gamma\alpha \equiv \begin{bmatrix} u & 0 \\ 0 & v \end{bmatrix} \pmod{N},$$

so that $\alpha\gamma \in \gamma\alpha\Gamma_1(N)$. Therefore we get

$$\Gamma_0(N)\alpha\Gamma_0(N) = \Gamma_0(N)\alpha\Gamma_1(N).$$

We note that $\begin{bmatrix} l & 0 \\ 0 & m \end{bmatrix}$ is not necessarily contained in $\Delta_1(N)$. Next let α be any element of $\Delta_1(N)$. Since $\alpha \in \Delta_0(N)$, there exist integers l and m such that

$$\Gamma_0(N)\alpha\Gamma_0(N) = \Gamma_0(N)\begin{bmatrix} l & 0 \\ 0 & m \end{bmatrix}\Gamma_0(N)$$

by Lemma 4.5.2. Therefore

$$\begin{aligned} \Gamma_0(N)\alpha\Gamma_1(N) &\subset \Gamma_0(N)\alpha\Gamma_0(N) \\ &= \Gamma_0(N)\begin{bmatrix} l & 0 \\ 0 & m \end{bmatrix}\Gamma_0(N) \\ &= \Gamma_0(N)\begin{bmatrix} l & 0 \\ 0 & m \end{bmatrix}\Gamma_1(N) \end{aligned}$$

and this implies

$$\Gamma_0(N)\alpha\Gamma_1(N) = \Gamma_0(N)\begin{bmatrix} l & 0 \\ 0 & m \end{bmatrix}\Gamma_1(N).$$

Therefore we obtain

$$\Gamma_0(N)\alpha\Gamma_0(N) = \Gamma_0(N)\alpha\Gamma_1(N). \quad \square$$

Next let Γ be a modular group such that

$$\Gamma_0(N) \supset \Gamma \supset \Gamma_1(N),$$

and put

$$\Delta = \Delta_1(N) \cdot \Gamma \subset \Delta_0(N).$$

From the proof of Theorem 4.5.18, we see easily

$$\mathcal{R}(\Gamma, \Delta) \simeq \mathcal{R}(\Gamma_0(N), \Delta_0(N))$$

and this isomorphism commutes with the natural embedding of $\mathcal{S}_k(\Gamma)$ into $\mathcal{S}_k(\Gamma_1(N))$. Hereafter we identify $\mathcal{R}(\Gamma_1(N), \Delta_1(N))$, $\mathcal{R}(\Gamma, \Delta)$ and $\mathcal{R}(\Gamma_0(N), \Delta_0(N))$, and write

$$\mathcal{R}(N) = \mathcal{R}(\Gamma_1(N), \Delta_1(N)) = \mathcal{R}(\Gamma, \Delta) = \mathcal{R}(\Gamma_0(N), \Delta_0(N)).$$

We quote from [Shimura]: Theorem 3.48 and Theorem 3.52 the following important

Theorem 4.5.19. *Let Γ be a modular group such that*

$$\Gamma_0(N) \supset \Gamma \supset \Gamma_1(N).$$

Assume $k \geq 2$.

(1) *The Hecke algebra $\mathcal{R}(N)$ is representable on $\mathcal{S}_k(\Gamma)$ by matrices with rational integral entries.*

(2) *There exists a basis of $\mathcal{S}_k(\Gamma)$ consisting of elements whose Fourier coefficients at ∞ are all rational integers.*

Since by (4.3.1),

$$\Gamma_0(N^2) \supset \begin{bmatrix} N & 0 \\ 0 & 1 \end{bmatrix}^{-1} \Gamma(N) \begin{bmatrix} N & 0 \\ 0 & 1 \end{bmatrix} \supset \Gamma_1(N^2),$$

the investigation of the Hecke algebra of $\Gamma(N)$ is reduced to that of a modular group Γ of above type.

§4.6. Primitive Forms

We assume $k > 0$ throughout this section. For a positive integer l , we put

$$(4.6.1) \quad \delta_l = \begin{bmatrix} l & 0 \\ 0 & 1 \end{bmatrix} \in GL_2^+(\mathbb{R}).$$

Then for a function $f(z)$ on \mathbf{H} ,

$$(4.6.2) \quad f(lz) = l^{-k/2} (f|_k \delta_l)(z).$$

Lemma 4.6.1. *If $f(z) \in \mathcal{G}_k(N, \chi)$, then for any positive integer l ,*

$$f(lz) = l^{-k/2} (f|_k \delta_l)(z) \in \mathcal{G}_k(lN, \chi).$$

Moreover, if $f(z)$ is a cusp form, so is $f(lz)$.

Proof. Let $f(z) \in \mathcal{G}_k(N, \chi)$ (resp. $\mathcal{S}_k(N, \chi)$), and put $g = f|_k \delta_l$. For any $\gamma = \begin{bmatrix} a & b \\ clN & d \end{bmatrix} \in \Gamma_0(lN)$, we have

$$\delta_l \gamma \delta_l^{-1} = \begin{bmatrix} a & bl \\ cN & d \end{bmatrix} \in \Gamma_0(N).$$

Therefore

$$\begin{aligned} g|_k \gamma &= (f|_k \delta_l \gamma \delta_l^{-1})|_k \delta_l \\ &= \chi(d) (f|_k \delta_l) \\ &= \chi(\gamma) g. \end{aligned}$$

By Lemma 2.1.3, we see $f(lz) \in \mathcal{G}_k(lN, \chi)$ (resp. $\mathcal{S}_k(lN, \chi)$). □

The Hecke operators $T(n)$ ($(n, N) = 1$) on $\mathcal{S}_k(N, \chi)$ are simultaneously diagonalizable. Furthermore, if $f(z)$ is a common eigenfunction of all Hecke operators $T(n)$, then the associated Dirichlet series $L(s; f)$ has an Euler product. We naturally ask the question whether all Hecke operators $T(n)$ on $\mathcal{S}_k(N, \chi)$ are simultaneously diagonalizable. In the case when $N = 1$, it is obviously true. Hecke proved that it is true for the following cases:

- 1° $\mathcal{S}_k(\Gamma_0(N))$ when N is prime, $k < 12$ or $k = 14$;
- 2° $\mathcal{S}_k(N, \chi)$ when χ is a primitive Dirichlet character of conductor N .

On the other hand, [Shimura, Remark 3.59] implies that $\mathcal{S}_k(N, \chi)$ does not necessarily have a basis consisting of eigenfunctions of all Hecke operators $T(n)$. This phenomenon arises from the fact that

$$(4.6.3) \quad \text{if } f(z) \in \mathcal{S}_k(N, \chi), \text{ then } f(z), f(lz) \in \mathcal{S}_k(lN, \chi).$$

In the above cases 1° and 2° , $\mathcal{S}_k(N, \chi)$ contains no cusp forms of smaller level. Thus we may expect that if we exclude cusp forms of lower levels, then all Hecke operators $T(n)$ are simultaneously diagonalizable on the complementary subspace. This is in fact true. We explain this result and some applications following [Atkin–Lehner] [Miyake], [Asai] and [Naganuma]. We start from the relation between Hecke operators and the embeddings.

Lemma 4.6.2. *For a positive integer l , we put $\delta_l = \begin{bmatrix} l & 0 \\ 0 & 1 \end{bmatrix}$. If $(n, lN) = 1$, then the following diagram is commutative:*

$$\begin{array}{ccc} \mathcal{G}_k(N, \chi) & \xrightarrow{T(n)} & \mathcal{G}_k(N, \chi) \\ \downarrow \delta_l & & \downarrow \delta_l \\ \mathcal{G}_k(lN, \chi) & \xrightarrow{T(n)} & \mathcal{G}_k(lN, \chi) \end{array}$$

Proof. Let $f(z)$ be an element of $\mathcal{G}_k(N, \chi)$, and put $g = f|_k \delta_l$. If $(n, lN) = 1$, then

$$f|T(n, n) = \chi(n)n^{k-2}f,$$

and

$$g|T(n, n) = \chi(n)n^{k-2}g.$$

Therefore we have only to prove the assertion for a prime number p prime to lN . By Lemma 4.5.6, we may take the set

$$\left\{ \begin{bmatrix} 1 & m \\ 0 & p \end{bmatrix}, \begin{bmatrix} p & 0 \\ 0 & 1 \end{bmatrix} \middle| 0 \leq m < p \right\}$$

as a complete set of representatives of $\Gamma_0(lN) \backslash \Gamma_0(lN) \begin{bmatrix} 1 & 0 \\ 0 & p \end{bmatrix} \Gamma_0(lN)$. Then

$$\begin{aligned} (f|_k \delta_l)|T(p) &= p^{k/2-1} \left\{ \sum_{m=0}^{p-1} f|_k \delta_l \begin{bmatrix} 1 & m \\ 0 & p \end{bmatrix} + \chi(p) f|_k \delta_l \begin{bmatrix} p & 0 \\ 0 & 1 \end{bmatrix} \right\} \\ &= p^{k/2-1} \left\{ \sum_{m=0}^{p-1} f|_k \begin{bmatrix} 1 & lm \\ 0 & p \end{bmatrix} \delta_l + \chi(p) f|_k \begin{bmatrix} p & 0 \\ 0 & 1 \end{bmatrix} \delta_l \right\}. \end{aligned}$$

Since l and p are coprime, the set

$$\left\{ \begin{bmatrix} 1 & lm \\ 0 & p \end{bmatrix}, \begin{bmatrix} p & 0 \\ 0 & 1 \end{bmatrix} \middle| 0 \leq m < p \right\}$$

is a complete set of representatives of $\Gamma_0(N)\backslash\Gamma_0(N)\begin{bmatrix} 1 & 0 \\ 0 & p \end{bmatrix}\Gamma_0(N)$, so that

$$= (f|T(p))|_k\delta_l. \quad \square$$

The following lemma used by Hecke in the cases 1° and 2° plays the fundamental role also in the general cases.

Lemma 4.6.3. (Hecke) *Let $f(z)$ be an element of $\mathcal{G}_k(N, \chi)$. If there exists an element*

$\alpha = \begin{bmatrix} a & b \\ c & d \end{bmatrix}$ *of $\Delta_0(N)$ satisfying the following conditions, then $f(z) = 0$.*

- (i) $\det(\alpha) > 1$, $(\det(\alpha), N) = 1$, $(a, b, c, d) = 1$;
- (ii) $f|_k\alpha \in \mathcal{G}_k(N, \chi)$.

Proof. By Lemma 4.5.2, there exist two elements γ_1, γ_2 of $\Gamma_0(N)$ such that

$$\gamma_1\alpha\gamma_2 = \begin{bmatrix} l & 0 \\ 0 & m \end{bmatrix} \quad (l|m, \quad m, l > 0).$$

By (i), $(l, m) = 1$, so that $l = 1$ and $m > 1$. Since

$$\begin{bmatrix} 1 & 0 \\ 0 & m \end{bmatrix} \begin{bmatrix} 1 & 1 \\ 0 & 1 \end{bmatrix} \begin{bmatrix} 1 & 0 \\ 0 & m \end{bmatrix}^{-1} = \begin{bmatrix} 1 & 1/m \\ 0 & 1 \end{bmatrix} \notin \Gamma_0(N),$$

we get

$$\alpha\Gamma_0(N)\alpha^{-1} \not\subset \Gamma_0(N).$$

Let γ be an element of $\Gamma_0(N)$ such that $\alpha\gamma\alpha^{-1} \notin \Gamma_0(N)$. Since

$$\det(\alpha)\alpha^{-1} = \begin{bmatrix} d & -b \\ -c & a \end{bmatrix} \in \Delta_0(N),$$

we see that $\det(\alpha)\alpha\gamma\alpha^{-1} \in \Delta_0(N)$. Thus we can take elements $\gamma_3, \gamma_4 \in \Gamma_0(N)$ so that

$$(4.6.4) \quad \det(\alpha)\gamma_3\alpha\gamma\alpha^{-1}\gamma_4 = \begin{bmatrix} u & 0 \\ 0 & v \end{bmatrix} \quad (u|v, \quad u, v > 0)$$

by Lemma 4.5.2. We see $uv = \det(\alpha)^2$ by taking the determinants of both sides. If $u = v$, then $\alpha\gamma\alpha^{-1} = \gamma_3^{-1}\gamma_4^{-1} \in \Gamma_0(N)$; which contradicts the assumption on γ . Therefore $h = v/u > 1$. Acting (4.6.4) on $f(z)$, we get

$$Cf(z) = f(z/h) \quad (C = h^{k/2}\chi(\gamma_3)\chi(\gamma)\chi(\gamma_4) \neq 0).$$

Let $f(z) = \sum_{n=0}^{\infty} a(n)e^{2\pi inz}$ be the Fourier expansion. Then

$$a(n) = C^{-1}a(n/h) = C^{-t}a(n/h^t)$$

for any positive integer t . Therefore we get $a(n) = 0$ if $n > 0$. Since $k > 0$, we obtain $f(z) = 0$. □

Theorem 4.6.4. *Let l be a positive integer. If a holomorphic function $f(z)$ on \mathbf{H} satisfies the two conditions:*

- (i) $f(z + 1) = f(z)$,
- (ii) $f(lz) \in \mathcal{G}_k(N, \chi)$,

then

- (1) if $lm_\chi | N$, then $f(z) \in \mathcal{G}_k(N/l, \chi)$;
- (2) if $lm_\chi \nmid N$, then $f(z) = 0$.

Here m_χ is the conductor of χ . Furthermore if $f(lz)$ is a cusp form, then so is $f(z)$.

Proof. We may assume that l is a prime number. First let us show $f(z) \in \mathcal{G}_k(N, \chi)$. Put $g(z) = f(lz)$ and

$$\Gamma' = \left\{ \begin{bmatrix} a & b \\ cN & d \end{bmatrix} \in \Gamma_0(N) \mid b \equiv 0 \pmod{l} \right\}.$$

Take an element $\gamma = \begin{bmatrix} a & bl \\ cN & d \end{bmatrix}$ of Γ' . Since

$$\delta_l^{-1} \gamma \delta_l = \begin{bmatrix} a & b \\ clN & d \end{bmatrix} \in \Gamma_0(N),$$

we see

$$g|_k \delta_l^{-1} \gamma \delta_l = \chi(d)g,$$

or

$$f|_k \delta_l \delta_l^{-1} \gamma \delta_l = \chi(d)f|_k \delta_l.$$

This implies $f|_k \gamma = \chi(d)f$. Let Γ'' be the group generated by Γ' and $\begin{bmatrix} 1 & 1 \\ 0 & 1 \end{bmatrix}$. Since

$$[\Gamma'' : \Gamma'] \geq l$$

and

$$[\Gamma_0(N) : \Gamma'] = \begin{cases} l & (l|N), \\ l+1 & (l \nmid N), \end{cases}$$

we see that $\Gamma'' = \Gamma_0(N)$ or $\Gamma_0(N)$ is generated by $\begin{bmatrix} 1 & 1 \\ 0 & 1 \end{bmatrix}$ over Γ' . Therefore by (i), $f(z)$ belongs to $\mathcal{G}_k(N, \chi)$. Next suppose l is prime to N . Then $f(z) = 0$ by taking $\alpha = \delta_l$ in Lemma 4.6.3. Now we assume $l|N$. For any element

$\gamma_1 = \begin{bmatrix} a & b \\ cN & d \end{bmatrix} \in \Gamma_0(N)$, we see

$$f|_k \begin{bmatrix} a & bl \\ cN/l & d \end{bmatrix} = f|_k \delta_l \gamma_1 \delta_l^{-1} = \chi(d)f,$$

and in particular,

$$f|_k \begin{bmatrix} 1 & 0 \\ N/l & 1 \end{bmatrix} = f.$$

Therefore, if we put

$$\gamma = \begin{bmatrix} 1 & m \\ 0 & 1 \end{bmatrix} \begin{bmatrix} 1 & 0 \\ N/l & 1 \end{bmatrix} \begin{bmatrix} 1 & n \\ 0 & 1 \end{bmatrix},$$

then $f|_k \gamma = f$. Let n be any integer such that

$$nN/l + 1 \not\equiv 0 \pmod{l}.$$

Then we can take an integer m so that

$$(4.6.5) \quad n(1 + mN/l) + m = n + m(nN/l + 1) \equiv 0 \pmod{l}.$$

Then

$$\delta_l^{-1} \gamma \delta_l = \begin{bmatrix} 1 + mN/l & \{n(1 + mN/l) + m\}/l \\ N & nN/l + 1 \end{bmatrix} \in \Gamma_0(N),$$

and hence

$$f|_k \gamma = \chi(1 + nN/l)f.$$

Therefore if $f(z) \neq 0$, then $\chi(1 + nN/l) = 1$ for any integer n satisfying $(nN/l + 1, l) = 1$. This implies that χ is defined mod N/l , and N is divisible by lm_χ . This implies

(2). Assume $lm_\chi | N$. Since $\Gamma_0(N/l)$ is generated by $\begin{bmatrix} 1 & 0 \\ N/l & 1 \end{bmatrix}$ over $\Gamma_0(N)$, we get $f(z) \in \mathcal{G}_k(N/l, \chi)$. The last assertion is obvious. \square

Lemma 4.6.5. *Let $f(z) = \sum_{n=0}^{\infty} a_n e^{2\pi inz}$ be an element of $\mathcal{G}_k(N, \chi)$. For a positive integer L , we put*

$$g(z) = \sum_{(n, L)=1} a_n e^{2\pi inz}.$$

Then $g(z) \in \mathcal{G}_k(M, \chi)$ with

$$M = N \prod_{\substack{p|L \\ p|N}} p \prod_{\substack{p|L \\ p \nmid N}} p^2.$$

Furthermore if $f(z)$ is a cusp form, so is $g(z)$.

Proof. We have only to prove the assertion when L is a prime number p . Put $N' = N$ or $N' = pN$ according as $p|N$ or not. Since $p|N'$, we have

$$(4.6.6) \quad \Gamma_0(N') \begin{bmatrix} 1 & 0 \\ 0 & p \end{bmatrix} \Gamma_0(N') = \prod_{m=0}^{p-1} \Gamma_0(N') \begin{bmatrix} 1 & m \\ 0 & p \end{bmatrix}$$

by Lemma 4.5.6. Since $\mathcal{G}_k(N, \chi) \subset \mathcal{G}_k(N', \chi)$, we get $f|^{N'} T(p) \in \mathcal{G}_k(N', \chi)$. By (4.6.6), we see

$$\begin{aligned} (f|^{N'} T(p))(z) &= p^{-1} \sum_{n=0}^{\infty} a_n \sum_{m=0}^{p-1} e^{2\pi i n(z+m)/p} \\ &= \sum_{n=0}^{\infty} a_{np} e^{2\pi inz}, \end{aligned}$$

so that

$$(f|^{N'} T(p))(pz) = \sum_{n=0}^{\infty} a_{np} e^{2\pi i npz},$$

which belongs to $\mathcal{G}_k(N'p, \chi)$ by Lemma 4.6.1. Therefore we obtain

$$g(z) = f(z) - (f|^{N'} T(p))(pz) \in \mathcal{G}_k(N'p, \chi).$$

The last assertion is obvious. \square

Lemma 4.6.6. *Let χ be a Dirichlet character mod N , l a positive integer, and p a prime number prime to l . Put $M = lN$. Then the following diagrams are commutative:*

$$(1) \begin{array}{ccc} \mathcal{G}_k(pN, \chi) & \xrightarrow{\Gamma_0(pN) \begin{bmatrix} 1 & 0 \\ 0 & p \end{bmatrix} \Gamma_0(N)} & \mathcal{G}_k(N, \chi) \\ \downarrow & & \downarrow \\ \mathcal{G}_k(pM, \chi) & \xrightarrow{\Gamma_0(pM) \begin{bmatrix} 1 & 0 \\ 0 & p \end{bmatrix} \Gamma_0(M)} & \mathcal{G}_k(M, \chi) \end{array}$$

Here the vertical arrows indicate the natural embeddings.

$$(2) \begin{array}{ccc} \mathcal{G}_k(pN, \chi) & \xrightarrow{\Gamma_0(pN) \begin{bmatrix} 1 & 0 \\ 0 & p \end{bmatrix} \Gamma_0(N)} & \mathcal{G}_k(N, \chi) \\ \downarrow \delta_l & & \downarrow \delta_l \\ \mathcal{G}_k(pM, \chi) & \xrightarrow{\Gamma_0(pM) \begin{bmatrix} 1 & 0 \\ 0 & p \end{bmatrix} \Gamma_0(M)} & \mathcal{G}_k(M, \chi) \end{array}$$

Similar results as above hold for cusp forms.

Proof. (1): By assumption, $p|N$ if and only if $p|M$. Therefore the assertion is obvious from Lemma 4.5.11. (2): Let $f(z)$ be an element of $\mathcal{G}_k(pN, \chi)$, and put $g = f|_k \delta_l$. We put

$$d = \begin{cases} p-1 & \text{if } p|M \\ p & \text{otherwise,} \end{cases}$$

and

$$\gamma_v = \begin{bmatrix} 1 & v \\ 0 & 1 \end{bmatrix} \quad (0 \leq v \leq p-1).$$

If $d = p$, then take an element γ_p of $\Gamma_0(M)$ as in Lemma 4.5.11. Then

$$(4.6.7) \quad \Gamma_0(pM) \begin{bmatrix} 1 & 0 \\ 0 & p \end{bmatrix} \Gamma_0(M) = \prod_{v=0}^d \Gamma_0(pM) \begin{bmatrix} 1 & 0 \\ 0 & p \end{bmatrix} \gamma_v,$$

so that

$$(4.6.8) \quad \begin{aligned} p^{1-k/2} g | \Gamma_0(pM) \begin{bmatrix} 1 & 0 \\ 0 & p \end{bmatrix} \Gamma_0(M) &= \sum_{v=0}^d g |_k \begin{bmatrix} 1 & 0 \\ 0 & p \end{bmatrix} \gamma_v \\ &= \sum_{v=0}^d f |_k \delta_l \begin{bmatrix} 1 & 0 \\ 0 & p \end{bmatrix} \gamma_v \\ &= \sum_{v=0}^d f |_k \begin{bmatrix} 1 & 0 \\ 0 & p \end{bmatrix} (\delta_l \gamma_v \delta_l^{-1}) \delta_l. \end{aligned}$$

Since

$$\delta_l \gamma_v \delta_l^{-1} = \begin{bmatrix} 1 & lv \\ 0 & 1 \end{bmatrix} \quad (0 \leq v \leq p-1),$$

and

$$\delta_l \gamma_p \delta_l^{-1} \equiv \begin{cases} \begin{bmatrix} 0 & -al \\ (al)^{-1} & 0 \end{bmatrix} & \text{mod } p, \\ \begin{bmatrix} 1 & 0 \\ 0 & 1 \end{bmatrix} & \text{mod } N, \end{cases}$$

provided $p \nmid N$, we see

$$\Gamma_0(pN) \begin{bmatrix} 1 & 0 \\ 0 & p \end{bmatrix} \Gamma_0(N) = \prod_{v=0}^d \Gamma_0(pN) \begin{bmatrix} 1 & 0 \\ 0 & p \end{bmatrix} (\delta_l \gamma_v \delta_l^{-1})$$

by Lemma 4.5.11. Therefore it follows from (4.6.8) that

$$g | \Gamma_0(pM) \begin{bmatrix} 1 & 0 \\ 0 & p \end{bmatrix} \Gamma_0(M) = \left(f | \Gamma_0(pN) \begin{bmatrix} 1 & 0 \\ 0 & p \end{bmatrix} \Gamma_0(N) \right) \Big|_k \delta_l. \quad \square$$

Lemma 4.6.7. *Let $l (> 1)$ be a positive square-free integer, and $f(z) = \sum_{n=0}^{\infty} a_n e^{2\pi inz}$ an element of $\mathcal{G}_k(N, \chi)$. If $a_n = 0$ for all n prime to l , then we can express*

$$f(z) = \sum_{p|l} g_p(pz) \quad (g_p(z) \in \mathcal{G}_k(Nl^2, \chi)),$$

where p runs over all prime factors of l . Furthermore if $l|N$, then we can take $g_p(z)$ from $\mathcal{G}_k(Nl, \chi)$. If $f(z)$ is a cusp form, all $g_p(z)$ can be taken as cusp forms.

Proof. We prove the assertion by induction on the number of the prime factors of l . First suppose l is prime. Then $g(z) = f(z/l)$ satisfies the conditions of Theorem 4.6.4, so that $g(z) \in \mathcal{G}_k(N/l, \chi)$ or $f(z) = g(z) = 0$ according as $lm_\chi | N$ or not. Consequently $g(z) \in \mathcal{G}_k(Nl, \chi)$ and

$$f(z) = g(lz).$$

Next assume that l is a composite number and the assertion is true for any proper divisor of l . Let p be a prime factor of l and $l' = l/p$. Put

$$h(z) = \sum_{(n, p)=1} a_n e^{2\pi inz}.$$

Then $h(z) \in \mathcal{G}_k(Np^2, \chi)$ by Lemma 4.6.5. Put

$$f(z) - h(z) = \sum_{n=0}^{\infty} b_n e^{2\pi inz}.$$

Then if $(n, p) = 1$, then $b_n = 0$. Put

$$g_p(z) = f(z/p) - h(z/p),$$

then $g_p(z) \in \mathcal{G}_k(Np, \chi)$ by the induction assumption, and

$$(4.6.9) \quad f(z) = g_p(pz) + h(z).$$

Moreover $h(z)$ satisfies the assumption of the lemma with Np^2 and l' in place of N and l , respectively. Therefore we can find $g_d(z) \in \mathcal{G}_k(Np^2l'^2, \chi) (= \mathcal{G}_k(Nl^2, \chi))$ for

each prime factor q of l' satisfying

$$h(z) = \sum_{q|l'} g_q(qz).$$

This combined with (4.6.9) implies the first half of the assertion. It is obvious from the above proof and Lemma 4.6.5 that if $l|N$, then we can take $g_p(z)$ from $\mathcal{G}_k(Nl, \chi)$. It is also obvious that we can take $g_p(z)$ from cusp forms when $f(z)$ is a cusp form. \square

The following theorem is a generalization of Theorem 4.6.4.

Theorem 4.6.8. *Let l be a positive integer, and $f(z) = \sum_{n=0}^{\infty} a_n e^{2\pi inz}$ an element of $\mathcal{G}_k(N, \chi)$. Let m_χ be the conductor of χ . Assume $a_n = 0$ for all n prime to l .*

(1) *If $(l, N/m_\chi) = 1$, then $f(z) = 0$.*

(2) *If $(l, N/m_\chi) \neq 1$, then there exist $f_p(z) \in \mathcal{G}_k(N/p, \chi)$ for all prime factors p of $(l, N/m_\chi)$ such that*

$$f(z) = \sum_{p|(l, N/m_\chi)} f_p(pz).$$

If $f(z)$ is a cusp form, then we can take $f_p(z)$ from cusp forms.

Proof. We may assume that l is square-free. We prove the assertion by induction on the number of the factors of l . When l is a prime number, the assertion is nothing but Theorem 4.6.4 for $f(z/l)$. Next assume that the assertion is true for any proper divisor of l . Let p be a prime factor of l , and put $l' = l/p$. We put

$$(4.6.10) \quad h(z) = \sum_{(n, l') \neq 1} a_n e^{2\pi inz},$$

$$(4.6.11) \quad g(z) = f(z) - h(z) = \sum_{(n, l') = 1} a_n e^{2\pi inz}.$$

We see $h(z)$ and $g(z)$ belong to $\mathcal{G}_k(Nl'^2, \chi)$ by Lemma 4.6.5. If $(n, p) = 1$, then the n -th Fourier coefficient of $g(z)$ vanishes. First assume $pm_\chi \nmid N$, then $pm_\chi \nmid Nl'^2$ and therefore $g(z) = 0$ by Theorem 4.6.4, namely,

$$f(z) = h(z) = \sum_{(n, l') \neq 1} a_n e^{2\pi inz}.$$

This implies that $f(z)$ satisfies the assumption for l' in place of l , and hence, the assertion is true by the induction assumption. Next assume $pm_\chi | N$ and put

$$g_p(z) = g(z/p).$$

Then $g_p(z) \in \mathcal{G}_k(Nl'^2/p, \chi)$ by Theorem 4.6.4. Put $d = p - 1$ if $p^2 | N$, or $d = p$ if $p^2 \nmid N$. Take elements γ_v ($0 \leq v \leq d$) of $\Gamma_0(Nl'^2/p)$ so that

$$\Gamma_0(Nl'^2) \begin{bmatrix} 1 & 0 \\ 0 & p \end{bmatrix} \Gamma_0(Nl'^2/p) = \prod_{v=0}^d \Gamma_0(Nl'^2) \begin{bmatrix} 1 & 0 \\ 0 & p \end{bmatrix} \gamma_v$$

(see Lemma 4.5.11). Then we see

$$\begin{aligned} g|_{\Gamma_0(Nl'^2)} \begin{bmatrix} 1 & 0 \\ 0 & p \end{bmatrix} \Gamma_0(Nl'^2/p) &= p^{k/2-1} \sum_{\nu=0}^d \overline{\chi(\gamma_\nu)} g|_k \begin{bmatrix} 1 & 0 \\ 0 & p \end{bmatrix} \gamma_\nu \\ &= p^{-1} \sum_{\nu=0}^d \overline{\chi(\gamma_\nu)} g_p|_k \gamma_\nu \\ &= (d+1)p^{-1} g_p. \end{aligned}$$

Thus we obtain

$$(4.6.12) \quad \begin{aligned} g(z) &= g_p(pz) \\ &= p(d+1)^{-1} \left(g|_{\Gamma_0(Nl'^2)} \begin{bmatrix} 1 & 0 \\ 0 & p \end{bmatrix} \Gamma_0(Nl'^2/p) \right) (pz). \end{aligned}$$

Put

$$f_p(z) = p(d+1)^{-1} \left(f|_{\Gamma_0(N)} \begin{bmatrix} 1 & 0 \\ 0 & p \end{bmatrix} \Gamma_0(N/p) \right) (z).$$

Then $f_p(z) \in \mathcal{G}_k(N/p, \chi)$, and by Lemma 4.6.6(1),

$$(4.6.13) \quad f_p(z) = p(d+1)^{-1} \left((f|_{\Gamma_0(Nl'^2)}) \begin{bmatrix} 1 & 0 \\ 0 & p \end{bmatrix} \Gamma_0(Nl'^2/p) \right) (z).$$

Let us show that $f(z) - f_p(pz)$ satisfies the assumption of the theorem for l' . It is obvious that $f(z) - f_p(pz) \in \mathcal{G}_k(N, \chi)$. We see

$$\begin{aligned} (4.6.14) \quad f(z) - f_p(pz) &= f(z) - f_p(pz) - g(z) + g_p(pz) \\ &= (f(z) - g(z)) \\ &\quad - p(d+1)^{-1} \left((f-g)|_{\Gamma_0(Nl'^2)} \begin{bmatrix} 1 & 0 \\ 0 & p \end{bmatrix} \Gamma_0(Nl'^2/p) \right) (pz) \\ &= h(z) - p(d+1)^{-1} \left(h|_{\Gamma_0(Nl'^2)} \begin{bmatrix} 1 & 0 \\ 0 & p \end{bmatrix} \Gamma_0(Nl'^2/p) \right) (pz). \end{aligned}$$

Since the n -th Fourier coefficient of $h(z)$ vanishes if n is prime to l' , we can express

$$h(z) = \sum_{q|l'} h_q(qz) \quad (h_q(z) \in \mathcal{G}_k(Nl'^3, \chi))$$

by Lemma 4.6.7. Moreover for any prime factor q of l' , we have

$$h|_{\Gamma_0(Nl'^2)} \begin{bmatrix} 1 & 0 \\ 0 & p \end{bmatrix} \Gamma_0(Nl'^2/p) = h|_{\Gamma_0(Nl'^3q)} \begin{bmatrix} 1 & 0 \\ 0 & p \end{bmatrix} \Gamma_0(Nl'^3q/p)$$

by Lemma 4.6.6(1). This combined with Lemma 4.6.6(2) implies

$$\begin{aligned} & \left(h | \Gamma_0(Nl'^2) \begin{bmatrix} 1 & 0 \\ 0 & p \end{bmatrix} \Gamma_0(Nl'^2/p) \right) (z) \\ &= \left(\left(\sum_{q|l'} q^{-k/2} h_q | \delta_q \right) \Big| \Gamma_0(Nl'^3 q) \begin{bmatrix} 1 & 0 \\ 0 & p \end{bmatrix} \Gamma_0(Nl'^3 q/p) \right) (z) \\ &= \sum_{q|l'} \left(h_q | \Gamma_0(Nl'^3) \begin{bmatrix} 1 & 0 \\ 0 & p \end{bmatrix} \Gamma_0(Nl'^3/p) \right) (qz), \end{aligned}$$

where $\delta_q = \begin{bmatrix} q & 0 \\ 0 & 1 \end{bmatrix}$. In particular, the n -th Fourier coefficient of $\left(h | \Gamma_0(Nl'^2) \begin{bmatrix} 1 & 0 \\ 0 & p \end{bmatrix} \Gamma_0(Nl'^2/p) \right) (z)$ vanishes provided $(n, l') = 1$. Consequently the n -th Fourier coefficients of $f(z) - f_p(pz)$ vanishes by (4.6.14). Therefore, by the induction assumption, we obtain that

$$f(z) - f_p(pz) = \sum_q f_q(qz) \quad (f_q(z) \in \mathcal{S}_k(N/q, \chi)),$$

where q runs over all prime factors of l' . This completes the proof of (2). If $f(z)$ is a cusp form, then the modular forms which appear in the proof can be taken as cusp forms. □

Hereafter we consider only cusp forms. We denote by $\mathcal{S}_k^1(N, \chi)$ the subspace of $\mathcal{S}_k(N, \chi)$ generated by the set

$$\bigcup_M \bigcup_l \{ f(lz) \mid f(z) \in \mathcal{S}_k(M, \chi) \}.$$

Here M runs over all positive integers such that $m_\chi | M$, $M | N$, and $M \neq N$; l runs over all positive divisors of N/M (including both 1 and N/M); m_χ is the conductor of χ . In other words, $\mathcal{S}_k^1(N, \chi)$ is the subspace of $\mathcal{S}_k(N, \chi)$ generated by cusp forms essentially of lower levels. Furthermore, we denote by $\mathcal{S}_k^0(N, \chi)$ the orthocomplement of $\mathcal{S}_k^1(N, \chi)$ in $\mathcal{S}_k(N, \chi)$ with respect to the Petersson inner product. Namely, $\mathcal{S}_k^0(N, \chi) = \mathcal{S}_k^1(N, \chi)^\perp$. We also write $\mathcal{S}_k^0(\Gamma_0(N)) = \mathcal{S}_k^0(N, \chi)$ and $\mathcal{S}_k^1(\Gamma_0(N)) = \mathcal{S}_k^1(N, \chi)$ with the trivial character $\chi \bmod N$. By definition, the following lemma is obvious.

- Lemma 4.6.9.** (1) *If χ is a primitive Dirichlet character of conductor N , then $\mathcal{S}_k(N, \chi) = \mathcal{S}_k^0(N, \chi)$.*
 (2) *If $m_\chi | M$, $M | N$ and $M \neq N$, then $\mathcal{S}_k(M, \chi) \subset \mathcal{S}_k^1(N, \chi)$.*
 (3) *$\mathcal{S}_k(N, \chi)$ is generated by the set*

$$\bigcup_M \bigcup_l \{ f(lz) \mid f(z) \in \mathcal{S}_k^0(M, \chi) \}.$$

Here M runs over all positive integers such that $m_\chi | M$ and $M | N$; l runs over all positive divisors of N/M (including both 1 and N/M).

Lemma 4.6.10. $\mathcal{S}_k^1(N, \chi)$ and $\mathcal{S}_k^0(N, \chi)$ are stable under Hecke operators $T(n)$ ($(n, N) = 1$).

Proof. Let $f(z) \in \mathcal{S}_k^1(N, \chi)$. By definition, we can write

$$f(z) = \sum_v f_v(l_v z) \quad (f_v(z) \in \mathcal{S}_k(M_v, \chi), \quad l_v M_v | N, M_v \neq N).$$

Put $g_v(z) = f_v(l_v z)$. Since $(n, l_v N) = 1$, we see

$$\begin{aligned} (f|T(n))(z) &= \sum_v (g_v|T(n))(z) \\ &= \sum_v (f_v|T(n))(l_v z) \end{aligned}$$

by Theorem 4.5.10 and Lemma 4.6.2. Thus $(f|T(n))(z) \in \mathcal{S}_k^1(N, \chi)$, namely, $\mathcal{S}_k^1(N, \chi)$ is stable under $T(n)$. By Theorem 4.5.4, the adjoint operator of the Hecke operator $T(n)$ on $\mathcal{S}_k(N, \chi)$ is $\bar{\chi}(n)T(n)$, and therefore, $\mathcal{S}_k^0(N, \chi)$ is also stable under $T(n)$. \square

It follows from the above lemma that subspaces $\mathcal{S}_k^0(N, \chi)$ and $\mathcal{S}_k^1(N, \chi)$ of $\mathcal{S}_k(N, \chi)$ have a basis consisting of common eigenfunctions of all Hecke operators $T(n)$ ($(n, N) = 1$).

Lemma 4.6.11. Let $f(z) = \sum_{n=1}^{\infty} a_n e^{2\pi i n z}$ be an element of $\mathcal{S}_k^0(N, \chi)$. If $f(z)$ is a common eigenfunction of Hecke operators $T(n)$ for all n prime to some integer L , then $a_1 \neq 0$.

Proof. Assume $a_1 = 0$. Then by Lemma 4.5.15(1), we see $a_n = 0$ for all n prime to L . Therefore $f(z) \in \mathcal{S}_k^1(N, \chi)$ by Theorem 4.6.8, which is a contradiction. \square

Theorem 4.6.12. Let $f(z)$ and $g(z)$ be elements of $\mathcal{S}_k^0(N, \chi)$ and $\mathcal{S}_k^1(N, \chi)$, respectively. If $f(z)$ and $g(z)$ are common eigenfunctions of $T(n)$ with the same eigenvalue for each n prime to some integer L , then $g(z)$ is a constant multiple of $f(z)$.

Proof. Let $f(z) = \sum_{n=1}^{\infty} a_n e^{2\pi i n z}$ be the Fourier expansion. Since $a_1 \neq 0$ by Lemma 4.6.11, we may assume $a_1 = 1$. Furthermore we may assume $N|L$. Put

$$g(z) = g^{(0)}(z) + g^{(1)}(z) \quad (g^{(0)}(z) \in \mathcal{S}_k^0(N, \chi), g^{(1)}(z) \in \mathcal{S}_k^1(N, \chi)).$$

By Lemma 4.6.10, both $g^{(0)}(z)$ and $g^{(1)}(z)$ are common eigenfunctions of $T(n)$ with the same eigenvalue a_n for each n prime to L . Assume $g^{(0)}(z) \neq 0$, and put

$$g^{(0)}(z) = \sum_{n=1}^{\infty} b_n e^{2\pi i n z}.$$

By Lemma 4.6.11, we have $b_1 \neq 0$. Let us show $g^{(0)}(z) = b_1 f(z)$.

We put

$$(4.6.15) \quad g^{(0)}(z) - b_1 f(z) = \sum_{n=1}^{\infty} c_n e^{2\pi i n z}.$$

Since $b_1 a_n = b_n$ for all n prime to L by Lemma 4.5.15(1), we get $c_n = 0$ for all n such that $(n, L) = 1$. Applying Theorem 4.6.8, we see $g^{(0)}(z) - b_1 f(z) \in \mathcal{S}_k^1(N, \chi)$, and

$$g^{(0)}(z) = b_1 f(z).$$

Next we shall prove that $g^{(1)}(z) = 0$. First suppose $N = m_\chi$, where m_χ is the conductor of χ . Then $\mathcal{S}_k^1(N, \chi) = 0$. In particular, $g^{(1)}(z) = 0$. Next assume $N \neq m_\chi$. We separate the proof into two steps.

(i) If $g^{(1)}(z) \neq 0$, then there exist a proper divisor M of N satisfying $m_\chi | M$, and a non-zero element $h(z)$ of $\mathcal{S}_k^0(M, \chi)$ such that $h | T(n) = a_n h$ for all n prime to L . In fact, by definition, we may write

$$(4.6.16) \quad g^{(1)}(z) = \sum_v h_v(l_v z), \quad (h_v(z) \in \mathcal{S}_k^0(M_v, \chi), l_v M_v | N, M_v \neq N).$$

Since M_v divides N , Lemma 4.6.10 implies that $\mathcal{S}_k^0(M_v, \chi)$ has a basis consisting of eigenfunctions of $T(n)$ for all n prime to L , so we may assume that all $h_v(z)$ are common eigenfunctions of $T(n)$ for all n prime to L . Lemma 4.6.2 implies that $h_v(l_v z)$ are also common eigenfunctions of $T(n)$ for all n prime to L . Since eigenfunctions with distinct eigenvalues are linearly independent, the summation on all $h_v(l_v z)$ whose eigenvalues for $T(n)$ are different from a_n must vanish. Therefore, by removing such functions we may assume that all $h_v(z)$ appearing on the right-hand side of (4.6.16) satisfy

$$h_v | T(n) = a_n h_v \quad ((n, L) = 1).$$

Therefore we may take any $h_v(z)$ and M_v as $h(z)$ and M , respectively.

(ii) Let $h(z) = c'_1 e^{2\pi i z} + \dots$ be the element of $\mathcal{S}_k^0(M, \chi)$ obtained in (i). Since $h | T(n) = a_n h$ for all n prime to L , we see $c'_1 \neq 0$ by Lemma 4.6.11. Put

$$h(z) - c'_1 f(z) = \sum_{n=1}^{\infty} d_n e^{2\pi i n z}.$$

Then by Lemma 4.5.15(1) $d_n = 0$ if $(n, L) = 1$, and by Theorem 4.6.8

$$h(z) - c'_1 f(z) \in \mathcal{S}_k^1(N, \chi).$$

Therefore

$$f(z) = -c'_1{}^{-1}(h(z) - c'_1 f(z)) + c'_1{}^{-1} h(z) \in \mathcal{S}_k^1(N, \chi);$$

this contradicts the fact that $f(z)$ is a nonzero element of $\mathcal{S}_k^0(N, \chi)$. Consequently we obtain $g^{(1)}(z) = 0$, and therefore,

$$g(z) = g^{(0)}(z) = b_1 f(z). \quad \square$$

We call an element $f(z) \in \mathcal{S}_k^0(N, \chi)$ a *primitive form of conductor N* if the following conditions are satisfied:

- (i) $f(z)$ is a common eigenfunction of all $T(n)$, $((n, N) = 1)$;
- (ii) let $f(z) = \sum_{n=1}^{\infty} a_n e^{2\pi i n z}$ be the Fourier expansion, then $a_1 = 1$.

We also call $\mathcal{S}_k^0(N, \chi)$ the *space of primitive forms of level N with character χ* .

Theorem 4.6.13. (1) *Primitive forms are common eigenfunctions of $\mathcal{R}(N) \cup \mathcal{R}^*(N)$.*
 (2) $\mathcal{S}_k^0(N, \chi)$ *has a basis consisting of primitive forms.*

Proof. (1): Let $f(z)$ be a primitive form in $\mathcal{S}_k^0(N, \chi)$, and $f|T(n) = a_n f$ for n prime to N . Let T and T^* be elements of $\mathcal{R}(N)$ and $\mathcal{R}^*(N)$, respectively. Since $\mathcal{R}(N)$ is commutative, T is commutative with $T(n)$. Furthermore since $f|T(n) = \chi(n)f|T^*(n)$ and T^* is commutative with $T^*(n)$, T^* is also commutative with $T(n)$. Therefore $f|T$ and $f|T^*$ are also common eigenfunctions of $T(n)$ with the same eigenvalue a_n . Therefore Theorem 4.6.12 implies that both $f|T$ and $f|T^*$ are constant multiples of $f(z)$, or

$$f|T = cf, \quad f|T^* = c'f.$$

(2): Since $\mathcal{S}_k^0(N, \chi)$ has a basis consisting of common eigenfunctions of all $T(n)$ ($(n, N) = 1$) by Theorem 4.5.4(3) and Lemma 4.6.10, (2) follows from (1) and Lemma 4.6.11. \square

Corollary 4.6.14. *Assume that there exists a common eigenfunction $f(z) \in \mathcal{S}_k(N, \chi)$ of $T(n)$ with eigenvalues a_n for all n prime to N . Then there exist a divisor M of N satisfying $m_\chi | M$ and a primitive form $g(z) \in \mathcal{S}_k^0(M, \chi)$ such that*

$$g|T(n) = a_n g$$

for all n prime to N . Moreover if $f(z) \notin \mathcal{S}_k^0(N, \chi)$, then $M \neq N$.

Proof. If $f(z) \in \mathcal{S}_k^0(N, \chi)$, then the assertion is obvious since $a_1 \neq 0$ by Lemma 4.6.11. Suppose $f(z) \notin \mathcal{S}_k^0(N, \chi)$. Then by (i) in the proof of Theorem 4.6.12, we have a divisor M of N and an element $g(z)$ of $\mathcal{S}_k^0(M, \chi)$ such that $g|T(n) = a_n g$ for all n prime to N . By Lemma 4.6.11, we can take a primitive form as $g(z)$. This proves the first half of the assertion. The latter part follows from Theorem 4.6.12. \square

Let $f(z) = \sum_{n=1}^{\infty} a_n e^{2\pi i n z}$ be a primitive form of $\mathcal{S}_k^0(N, \chi)$. Then by Lemma 4.5.15(1),

$$f|T(n) = a_n f \quad \text{for all } n.$$

Moreover since $f(z)$ is an eigenfunction of $T^*(n)$, and $T^*(n)$ is the adjoint operator of $T(n)$ with respect to the Petersson inner product by Theorem 4.5.4(2), we get

$$f|T^*(n) = \bar{a}_n f.$$

Furthermore Theorem 4.5.4(1) implies that

$$(4.6.17) \quad \bar{a}_n = \bar{\chi}(n)a_n \quad \text{if } (n, N) = 1.$$

Moreover we see by Theorem 4.5.5

$$(4.6.18) \quad \begin{aligned} (f|_k \omega_N)|T(n) &= \bar{a}_n (f|_k \omega_N), \\ (f|_k \omega_N)|T^*(n) &= a_n (f|_k \omega_N), \end{aligned}$$

for all positive integers n .

Theorem 4.6.15. (1) *By the action of ω_N , $\mathcal{S}_k^0(N, \chi)$ and $\mathcal{S}_k^1(N, \chi)$ are isomorphic to $\mathcal{S}_k^0(N, \bar{\chi})$ and $\mathcal{S}_k^1(N, \bar{\chi})$, respectively.*

(2) *If $f(z)$ is a primitive form of $\mathcal{S}_k^0(N, \chi)$, then $f_\rho(z)$ is a primitive form of $\mathcal{S}_k^0(N, \bar{\chi})$ and*

$$f|_k \omega_N = cf_\rho(z) \quad (c \in \mathbb{C}).$$

Proof. (1): First let us prove that ω_N maps $\mathcal{S}_k^1(N, \chi)$ into $\mathcal{S}_k^1(N, \bar{\chi})$. We have only to show that if

$$f(z) = (h|_k \delta_l)(z) \quad (h(z) \in \mathcal{S}_k(M, \chi), M \neq N, lM|N),$$

then $f|_k \omega_N \in \mathcal{S}_k^1(N, \bar{\chi})$. Put $l' = N/lM$. Since

$$\delta_l \omega_N \delta_{l'}^{-1} = l' \omega_M,$$

we see

$$\begin{aligned} f|_k \omega_N &= h|_k (\delta_l \omega_N \delta_{l'}^{-1}) \delta_{l'} \\ &= (h|_k \omega_M)|_k \delta_{l'}. \end{aligned}$$

Since $h|_k \omega_M \in \mathcal{S}_k(M, \bar{\chi})$, we get $f|_k \omega_N \in \mathcal{S}_k^1(N, \bar{\chi})$. Next assume $f(z) \in \mathcal{S}_k^0(N, \chi)$. We see

$$(f|_k \omega_N, h) = (f, (-1)^k h|_k \omega_N) = 0$$

for all $h(z) \in \mathcal{S}_k^1(N, \bar{\chi})$ by Theorem 2.8.2. Therefore $f|_k \omega_N \in \mathcal{S}_k^0(N, \bar{\chi})$. Since $\mathcal{S}_k(N, \chi)$ is isomorphic to $\mathcal{S}_k(N, \bar{\chi})$ by ω_N , we obtain $\mathcal{S}_k^0(N, \chi) \simeq \mathcal{S}_k^0(N, \bar{\chi})$ and $\mathcal{S}_k^1(N, \chi) \simeq \mathcal{S}_k^1(N, \bar{\chi})$, respectively. (2): Since $f|_k \omega_N$ is an element of $\mathcal{S}_k^0(N, \bar{\chi})$ and it is a common eigenfunction of $\mathcal{R}(N)$, it is a constant multiple of a primitive form. On the other hand, $f|_k \omega_N$ is also a constant multiple of $f_\rho(z)$ by (4.6.18), and $a_1 = 1$. Therefore $f_\rho(z)$ is a primitive form. \square

Let $f(z) = \sum_{n=1}^\infty a_n e^{2\pi i n z}$ be a primitive form of $\mathcal{S}_k^0(N, \chi)$. By Theorem 4.5.16, we have the Euler product

$$\begin{aligned} L(s; f) &= \prod_p (1 - a_p p^{-s} + \chi(p) p^{k-1-2s})^{-1} \\ &= \prod_{p \nmid N} (1 - a_p p^{-s} + \chi(p) p^{k-1-2s})^{-1} \times \prod_{p|N} (1 - a_p p^{-s})^{-1}. \end{aligned}$$

We mentioned in Theorem 4.5.17 without proof that if $p \nmid N$, then $|a_p| \leq 2p^{(k-1)/2}$. We are going to give a similar estimate of a_p for a prime factor p of N . Let p be any prime factor of N , N_p the p -component of N , and χ_p the Dirichlet character mod N_p defined by (3.1.4). Moreover for a prime factor q of N , we put

$$\chi'_q = \prod_{p \neq q} \chi_p.$$

Let γ_q and γ'_q be two elements of $SL_2(\mathbb{Z})$ such that

$$(4.6.19) \quad \gamma_q \equiv \begin{cases} \begin{bmatrix} 0 & -1 \\ 1 & 0 \end{bmatrix} & \text{mod } N_q^2, \\ \begin{bmatrix} 1 & 0 \\ 0 & 1 \end{bmatrix} & \text{mod } (N/N_q)^2, \end{cases}$$

and

$$(4.6.20) \quad \gamma'_q \equiv \begin{cases} \begin{bmatrix} 1 & 0 \\ 0 & 1 \end{bmatrix} & \text{mod } N_q^2, \\ \begin{bmatrix} 0 & -1 \\ 1 & 0 \end{bmatrix} & \text{mod } (N/N_q)^2. \end{cases}$$

We put

$$(4.6.21) \quad \eta_q = \eta_q^{(N)} = \gamma_q \begin{bmatrix} N_q & 0 \\ 0 & 1 \end{bmatrix}, \quad \eta'_q = \gamma'_q \begin{bmatrix} N/N_q & 0 \\ 0 & 1 \end{bmatrix}.$$

Then

$$\eta_q \equiv \begin{cases} \begin{bmatrix} 0 & -1 \\ N_q & 0 \end{bmatrix} & \text{mod } N_q^2, \\ \begin{bmatrix} N_q & 0 \\ 0 & 1 \end{bmatrix} & \text{mod } (N/N_q)^2, \end{cases}$$

and

$$\eta'_q \equiv \begin{cases} \begin{bmatrix} N/N_q & 0 \\ 0 & 1 \end{bmatrix} & \text{mod } N_q^2, \\ \begin{bmatrix} 0 & -1 \\ N/N_q & 0 \end{bmatrix} & \text{mod } (N/N_q)^2. \end{cases}$$

Since

$$\eta_q \begin{bmatrix} a & b \\ cN & d \end{bmatrix} \eta_q^{-1} \equiv \begin{cases} \begin{bmatrix} d & -(N/N_q)c \\ -N_q b & a \end{bmatrix} & \text{mod } N_q^2, \\ \begin{bmatrix} a & N_q b \\ (N/N_q)c & d \end{bmatrix} & \text{mod } (N/N_q)^2, \end{cases}$$

and

$$\eta'_q \begin{bmatrix} a & b \\ cN & d \end{bmatrix} \eta_q^{-1} \equiv \begin{cases} \begin{bmatrix} a & (N/N_q)b \\ N_q c & d \end{bmatrix} & \text{mod } N_q, \\ \begin{bmatrix} d & -N_q c \\ -(N/N_q)b & a \end{bmatrix} & \text{mod } N/N_q^2, \end{cases}$$

we see

$$\eta_q \Gamma_0(N) \eta_q^{-1} = \Gamma_0(N), \quad \eta'_q \Gamma_0(N) \eta_q^{-1} = \Gamma_0(N),$$

and

$$\chi(\eta_q \gamma \eta_q^{-1}) = (\chi'_q \bar{\chi}_q)(\gamma), \quad \chi(\eta'_q \gamma \eta_q^{-1}) = (\bar{\chi}_q \chi_q)(\gamma), \quad (\gamma \in \Gamma_0(N)).$$

Therefore we get the isomorphisms

$$\mathcal{S}_k(N, \chi) \simeq \mathcal{S}_k(N, \chi'_q \bar{\chi}_q), \quad \mathcal{S}_k(N, \chi) \simeq \mathcal{S}_k(N, \bar{\chi}_q \chi_q),$$

by the correspondences “ $f \mapsto f|_k \eta_q$ ”, “ $f \mapsto f|_k \eta'_q$ ”, respectively. By a similar argument as in the proof of Theorem 4.5.5, we obtain the following commutative diagrams:

(4.6.22) if $(n, N_q) = 1$, then

$$\begin{array}{ccc} \mathcal{S}_k(N, \chi) & \xrightarrow{\bar{\chi}_q(n) T(n)} & \mathcal{S}_k(N, \chi) \\ \downarrow \eta_q & & \downarrow \eta_q \\ \mathcal{S}_k(N, \chi'_q \bar{\chi}_q) & \xrightarrow{T(n)} & \mathcal{S}_k(N, \chi'_q \bar{\chi}_q); \end{array}$$

(4.6.23) if $(n, N/N_q) = 1$, then

$$\begin{array}{ccc} \mathcal{S}_k(N, \chi) & \xrightarrow{\bar{\chi}'_q(n) T(n)} & \mathcal{S}_k(N, \chi) \\ \downarrow \eta'_q & & \downarrow \eta'_q \\ \mathcal{S}_k(N, \bar{\chi}'_q \chi_q) & \xrightarrow{T(n)} & \mathcal{S}_k(N, \bar{\chi}'_q \chi_q). \end{array}$$

In particular, if an element $f(z)$ of $\mathcal{S}_k(N, \chi)$ is a common eigenfunction of $T(n)$ for all n prime to N , so are $f|_k \eta_q$ and $f|_k \eta'_q$. Since for a prime divisor l of N

$$\delta_l \eta_q^{(N)} = c \gamma \eta_q^{(N/l)} \delta_{l'}, \quad \text{with } c \in \mathbb{Z}, \gamma \in \Gamma_0(N), \quad l' = \begin{cases} 1 & (l = q), \\ l & (l \neq q), \end{cases}$$

a similar argument as in the proof of Theorem 4.6.15 combined with these proves the first assertion of the following

Theorem 4.6.16. *Under the same notation and assumptions as above, we have:*

(1) By η_q , we have the isomorphisms:

$$\mathcal{S}_k^0(N, \chi) \simeq \mathcal{S}_k^0(N, \chi'_q \bar{\chi}_q), \quad \mathcal{S}_k^1(N, \chi) \simeq \mathcal{S}_k^1(N, \chi'_q \bar{\chi}_q).$$

(2) By η'_q , we have the isomorphisms:

$$\mathcal{S}_k^0(N, \chi) \simeq \mathcal{S}_k^0(N, \bar{\chi}'_q \chi_q), \quad \mathcal{S}_k^1(N, \chi) \simeq \mathcal{S}_k^1(N, \bar{\chi}'_q \chi_q).$$

(3) $f|_k \eta_q^2 = \chi_q(-1) \bar{\chi}'_q(N_q) f$, $f|_k \eta_q'^2 = \chi'_q(-1) \bar{\chi}_q(N/N_q) f$,

$$f|_k \eta_q \eta_q' = \bar{\chi}'_q(N_q) f|_k \omega_N,$$

for $f(z) \in \mathcal{S}_k(N, \chi)$.

(4) Let $f(z) = \sum_{n=1}^{\infty} a_n e^{2\pi i n z}$ be a primitive form of $\mathcal{S}_k^0(N, \chi)$.

Put

$$(f|_k \eta_q)(z) = c \sum_{n=1}^{\infty} b_n e^{2\pi i n z} \quad (b_1 = 1),$$

and

$$g_q(z) = \sum_{n=1}^{\infty} b_n e^{2\pi i n z}.$$

Then $g_q(z)$ is a primitive form of $\mathcal{S}_k^0(N, \chi_q \bar{\chi}_q)$ and

$$b_p = \begin{cases} \bar{\chi}_q(p) a_p & \text{if } p \neq q, \\ \chi'_q(p) \bar{a}_p & \text{if } p = q, \end{cases}$$

for any prime number p .

Proof. (2): This can be proved similarly to (1). (3): We put $\gamma = \eta_q \eta'_q \omega_N^{-1}$, then $\gamma \in \Gamma_0(N)$ and

$$\gamma \equiv \begin{cases} \begin{bmatrix} 1 & 0 \\ 0 & 1 \end{bmatrix} & \text{mod } N_q, \\ \begin{bmatrix} N_q & 0 \\ 0 & 1/N_q \end{bmatrix} & \text{mod } N/N_q. \end{cases}$$

Therefore we see

$$f|_k \eta_q \eta'_q = f|_k \gamma \omega_N = \overline{\chi'_q(N_q)} f|_k \omega_N.$$

Similarly, putting

$$\delta = \eta_q^2 \begin{bmatrix} N_q & 0 \\ 0 & N_q \end{bmatrix}^{-1},$$

we see $\delta \in \Gamma_0(N)$ and

$$\delta \equiv \begin{cases} \begin{bmatrix} -1 & 0 \\ 0 & -1 \end{bmatrix} & \text{mod } N_q, \\ \begin{bmatrix} N_q & 0 \\ 0 & 1/N_q \end{bmatrix} & \text{mod } N/N_q. \end{cases}$$

and therefore,

$$\begin{aligned} f|_k \eta_q^2 &= f|_k \delta \begin{bmatrix} N_q & 0 \\ 0 & N_q \end{bmatrix} \\ &= \chi_q(-1) \overline{\chi'_q(N_q)} f. \end{aligned}$$

A similar argument is applicable to $\eta_q'^2$. (4): By (4.6.22), if $(n, q) = 1$, then

$$(4.6.24) \quad \begin{aligned} (f|_k \eta_q) | T(n) &= \bar{\chi}_q(n) (f| T(n))|_k \eta_q \\ &= \bar{\chi}_q(n) a_n (f|_k \eta_q). \end{aligned}$$

Similarly, if $(n, N/N_q) = 1$, then

$$(4.6.25) \quad (f|_k \eta'_q) | T(n) = \overline{\chi'_q(n)} a_n (f|_k \eta'_q).$$

Since $f|_k \eta_q$ belongs to $\mathcal{S}_k^0(N, \chi_q \bar{\chi}_q)$ by (1), $f|_k \eta_q$ is a constant multiple of a primitive form, so that $g_q(z)$ is a primitive form. Taking a prime number p as n in (4.6.24), we get

$$b_p = \bar{\chi}_q(p) a_p, \quad (p \neq q).$$

It follows from (3) that

$$f|_k \eta_q = c(f|_k \omega_N \eta'_q) \quad (c = \chi'_q(-1) \overline{\chi'_q(N_q)} \chi_q(N/N_q)).$$

Since $f|_k \omega_N \in \mathcal{S}_k(N, \bar{\chi})$, we see by (4.6.23) that

$$\begin{aligned} (f|_k \eta_q)|T(q) &= c(f|_k \omega_N \eta'_q)|T(q) \\ &= c\chi'_q(q)((f|_k \omega_N)|T(q))|_k \eta'_q \\ &= c\chi'_q(q)\bar{a}_q(f|_k \omega_N \eta'_q) \\ &= \chi'_q(q)\bar{a}_q(f|_k \eta_q). \end{aligned}$$

Therefore we obtain

$$b_q = \chi'_q(q)\bar{a}_q. \quad \square$$

Theorem 4.6.17. *Let $f(z) = \sum_{n=1}^{\infty} a_n e^{2\pi i n z}$ be a primitive form of $\mathcal{S}_k^0(N, \chi)$, and m the conductor of χ . For a prime factor q of N , we denote by N_q and m_q the q -components of N and m , respectively.*

- (1) *If $N_q = m_q$, then $|a_q| = q^{(k-1)/2}$.*
- (2) *If $N_q = q$ and $m_q = 1$, then $a_q^2 = \chi'_q(q)q^{k-2}$.*
- (3) *Otherwise, namely, if $q^2|N_q$ and $N_q \neq m_q$, then $a_q = 0$.*

Proof. (1): Let γ_q and η_q be the elements of $GL_2(\mathbb{Q})$ defined by (4.6.19) and (4.6.21), respectively. Let a be an integer prime to N_q . Taking an integer b so that

$$ab + 1 \equiv 0 \pmod{N_q}, \quad a \equiv b \pmod{N/N_q},$$

we put

$$\gamma = \begin{bmatrix} 1 & a \\ 0 & N_q \end{bmatrix} \gamma_q \begin{bmatrix} 1 & b \\ 0 & N_q \end{bmatrix}^{-1}.$$

Then $\gamma \in SL_2(\mathbb{Z})$ and

$$\gamma \equiv \begin{cases} \begin{bmatrix} a & * \\ 0 & -b \end{bmatrix} \pmod{N_q}, \\ \begin{bmatrix} 1 & 0 \\ 0 & 1 \end{bmatrix} \pmod{N/N_q}, \end{cases}$$

so that $\gamma \in \Gamma_0(N)$ and $\chi(\gamma) = \chi_q(-b)$. Therefore

$$f|_k \begin{bmatrix} 1 & a \\ 0 & N_q \end{bmatrix} \gamma_q = \chi_q(-b) f|_k \begin{bmatrix} 1 & b \\ 0 & N_q \end{bmatrix}.$$

Consequently, taking the summation \sum' over a complete set of representatives of $(\mathbb{Z}/N_q\mathbb{Z})^\times$, we see

$$\begin{aligned} (4.6.26) \quad & N_q^{k/2-1} \left(\sum'_a f|_k \begin{bmatrix} 1 & a \\ 0 & N_q \end{bmatrix} \right) \Big|_k \eta_q \\ &= N_q^{k/2-1} \left(\sum'_a \chi_q(-a) f|_k \begin{bmatrix} 1 & a \\ 0 & N_q \end{bmatrix} \right) \Big|_k \begin{bmatrix} N_q & 0 \\ 0 & 1 \end{bmatrix} \end{aligned}$$

$$\begin{aligned}
 &= N_q^{k/2-1} \chi_q(-1) \sum_{n=1}^{\infty} \left(\sum'_a \chi_q(a) e^{2\pi i n a / N_q} \right) a_n e^{2\pi i n z} \\
 &= N_q^{k/2-1} W(\chi_q) \chi_q(-1) \sum_{n=1}^{\infty} \bar{\chi}_q(n) a_n e^{2\pi i n z}
 \end{aligned}$$

with the Gauss sum $W(\chi_q)$. We note that χ_q is a primitive Dirichlet character of conductor N_q . On the other hand, Lemma 4.5.6 implies that

$$\begin{aligned}
 (4.6.27) \quad N_q^{k/2-1} \left(\sum'_a f|_k \begin{bmatrix} 1 & a \\ 0 & N_q \end{bmatrix} \right) &= f|T(q^e) - q^{k/2-1} (f|T(q^{e-1}))|_k \begin{bmatrix} 1 & 0 \\ 0 & q \end{bmatrix} \\
 &= a_q^e f - q^{k/2-1} a_q^{e-1} f|_k \begin{bmatrix} 1 & 0 \\ 0 & q \end{bmatrix},
 \end{aligned}$$

where $N_q = q^e$. Next put

$$\delta = \begin{bmatrix} 1 & 0 \\ 0 & q \end{bmatrix} \eta_q \left(\eta_q \begin{bmatrix} q & 0 \\ 0 & 1 \end{bmatrix} \right)^{-1}.$$

Since $\delta \in \Gamma_0(N)$ and

$$\delta \equiv \begin{cases} \begin{bmatrix} 1 & 0 \\ 0 & 1 \end{bmatrix} & \text{mod } N_q, \\ \begin{bmatrix} 1/q & 0 \\ 0 & q \end{bmatrix} & \text{mod } N/N_q, \end{cases}$$

we obtain

$$\begin{aligned}
 (4.6.28) \quad N_q^{k/2-1} \left(\sum'_a f|_k \begin{bmatrix} 1 & a \\ 0 & N_q \end{bmatrix} \right) |_{\eta_q} \\
 = a_q^e f|_k \eta_q - \chi'_q(q) q^{k/2-1} a_q^{e-1} \left(f|_k \eta_q \begin{bmatrix} q & 0 \\ 0 & 1 \end{bmatrix} \right).
 \end{aligned}$$

Let $g(z) = \sum_{n=1}^{\infty} b_n e^{2\pi i n z}$ be a primitive form of $\mathcal{S}_k(N, \chi'_q \bar{\chi}_q)$ such that

$$f|_k \eta_q = c g, \quad (c \neq 0).$$

Comparing the first and q -th Fourier coefficients of the right-hand sides of (4.6.26) and (4.6.28), respectively, we get

$$(4.6.29) \quad N_q^{k/2-1} W(\chi_q) \chi_q(-1) = c a_q^e,$$

and

$$(4.6.30) \quad c(a_q^e b_q - \chi'_q(q) q^{k-1} a_q^{e-1}) = 0.$$

Since $b_q = \chi'_q(q) \bar{a}_q$ by Theorem 4.6.16(4), we obtain

$$|a_q|^2 = q^{k-1}.$$

Furthermore it follows from (4.6.29) that

$$(4.6.31) \quad c = N_q^{k/2-1} W(\chi_q) \chi_q(-1) / a_q^e.$$

(2): Since $N_q = q$, we have, by Lemma 4.5.6 and Lemma 4.5.11,

$$\Gamma_0(N) \begin{bmatrix} 1 & 0 \\ 0 & q \end{bmatrix} \Gamma_0(N/q) = \Gamma_0(N) \begin{bmatrix} 1 & 0 \\ 0 & q \end{bmatrix} \Gamma_0(N) \cup \Gamma_0(N) \eta_q \quad (\text{disjoint union}).$$

Moreover the assumption $m_q = 1$ implies that χ_q is a trivial character. Therefore, putting

$$g = f | \Gamma_0(N) \begin{bmatrix} 1 & 0 \\ 0 & q \end{bmatrix} \Gamma_0(N/q),$$

we have $g(z) \in \mathcal{S}_k(N/q, \chi'_q)$ and

$$g = f | T(q) + q^{k/2-1} \chi'_q(q) f |_k \eta_q.$$

Since $T(n) ((n, N) = 1)$ is commutative with $T(q)$, and also with η_q by (4.6.22), $g(z)$ is a common eigenfunction of $T(n)$ for all n prime to N with the same eigenvalue as $f(z)$. Since $\mathcal{S}_k(N/q, \chi'_q)$ is contained in $\mathcal{S}_k(N, \chi)$, Theorem 4.6.12 implies that

$$g(z) = af(z) \quad (a \in \mathbb{C}).$$

Since $f(z)$ is a primitive form of conductor N and $g(z)$ belongs to $\mathcal{S}_k(N/q, \chi'_q)$, we get $g(z) = 0$, namely,

$$(4.6.32) \quad a_q f(z) = -q^{k/2-1} \chi'_q(q) f |_k \eta_q,$$

or

$$(4.6.33) \quad f |_k \eta_q = -a_q \overline{\chi'_q(q)} q^{1-k/2} f.$$

Acting η_q on both sides, we obtain by Theorem 4.6.16(3),

$$(4.6.34) \quad a_q^2 = \chi'_q(q) q^{k-2}.$$

(3): By assumption, q divides N/q , so that

$$\Gamma_0(N) \begin{bmatrix} 1 & 0 \\ 0 & q \end{bmatrix} \Gamma_0(N/q) = \Gamma_0(N) \begin{bmatrix} 1 & 0 \\ 0 & q \end{bmatrix} \Gamma_0(N)$$

by Lemma 4.5.6 and Lemma 4.5.11. A similar argument as in the proof of (2) combined with this implies

$$f | T(q) = f | \Gamma_0(N) \begin{bmatrix} 1 & 0 \\ 0 & q \end{bmatrix} \Gamma_0(N/q) = 0.$$

This proves (3). □

We restate (4.6.31) and (4.6.33) as

Corollary 4.6.18. *Under the notation and assumptions in Theorem 4.6.16 and Theorem 4.6.17, we have:*

(1) *If $N_q = m_q$, then*

$$f |_k \eta_q = cg_q, \quad c = N_q^{-k/2} W(\chi_q) \chi_q(-1) \bar{a}_q^e, \quad (N_q = q^e),$$

with a primitive form $g_q(z)$ of $\mathcal{S}_k^0(N, \chi'_q \bar{\chi}_q)$.

(2) If $N_q = q$ and $m_q = 1$, then

$$f|_k \eta_q = cf, \quad c = -q^{1-k/2} \bar{a}_q,$$

and

$$\bar{a}_q = \overline{\chi_q(q)} a_q.$$

We are going to prove that two primitive forms are equal if almost all a_p are equal. More precisely,

Theorem 4.6.19. *Let $f(z) = \sum_{n=1}^{\infty} a_n e^{2\pi i n z}$ be a primitive form of $\mathcal{S}_k^0(N, \chi)$, and $g(z) = \sum_{n=1}^{\infty} b_n e^{2\pi i n z}$ an element of $\mathcal{S}_k(M, \lambda)$. If $g(z)$ is a common eigenfunction of $\mathcal{R}(M) \cup \mathcal{R}^*(M)$, $b_1 = 1$, and $a_n = b_n$ for all n prime to some integer L , then $N = M$ and $f(z) = g(z)$.*

Proof. We may assume that L is a common multiple of N and M . If p is a prime number prime to L , then we see

$$\begin{aligned} \chi(p)p^{k-1} &= a_p^2 - a_{p^2} \\ &= b_p^2 - b_{p^2} \\ &= \lambda(p)p^{k-1} \end{aligned}$$

by Lemma 4.5.7(2), so that $\chi(p) = \lambda(p)$. Therefore $\chi(n) = \lambda(n)$ for all integers n prime to L . Let us prove $M|N$. By Corollary 4.3.7, we have

$$(4.6.35) \quad \frac{A_N(s; f)}{A_M(s; g)} = \frac{A_N(k-s; f|_k \omega_N)}{A_M(k-s; g|_k \omega_M)}.$$

Since $L(s; f)$ and $L(s; g)$ have Euler products by Theorem 4.5.16, we see

$$(4.6.36) \quad \frac{A_N(s; f)}{A_M(s; g)} = (\sqrt{N}/\sqrt{M})^s \prod_{p|L} \frac{1 - b_p p^{-s} + \lambda(p)p^{k-1-2s}}{1 - a_p p^{-s} + \chi(p)p^{k-1-2s}}$$

on $\text{Re}(s) > k/2 + 1$. Since the right-hand side is a meromorphic function on the whole s -plane, (4.6.36) holds on the whole s -plane. On the other hand, $g|T(n) = b_n g$, and $g(z)$ is a common eigenfunction of $T^*(n)$ by assumption. Since $T^*(n)$ is the adjoint operator of $T(n)$, we see $g|T^*(n) = \bar{b}_n g$, and

$$(g|_k \omega_M)|T(n) = \bar{b}_n (g|_k \omega_M)$$

by Theorem 4.5.5. Therefore Theorem 4.5.16 implies that $L(s; g|_k \omega_M)$ also has an Euler product. This combined with Theorem 4.6.15(2) implies

$$(4.6.37) \quad \frac{A_N(k-s; f|_k \omega_N)}{A_M(k-s; g|_k \omega_M)} = c (\sqrt{N}/\sqrt{M})^{k-s} \prod_{p|L} \frac{1 - \bar{b}_p p^{s-k} + \bar{\lambda}(p)p^{2s-k-1}}{1 - \bar{a}_p p^{s-k} + \bar{\chi}(p)p^{2s-k-1}}$$

with a constant c . Thus by (4.6.35), we get

$$\begin{aligned} &(N/M)^s \prod_{p|L} \frac{1 - b_p p^{-s} + \lambda(p)p^{k-1-2s}}{1 - a_p p^{-s} + \chi(p)p^{k-1-2s}} \\ &= c (\sqrt{N}/\sqrt{M})^k \prod_{p|L} \frac{1 - \bar{b}_p p^{s-k} + \bar{\lambda}(p)p^{2s-k-1}}{1 - \bar{a}_p p^{s-k} + \bar{\chi}(p)p^{2s-k-1}}. \end{aligned}$$

We denote by M_p and N_p the p -components of M and N , respectively. Then we see, for any prime factor p of L ,

$$(4.6.38) \quad (N_p/M_p)^s \frac{1 - b_p p^{-s} + \lambda(p) p^{k-1-2s}}{1 - a_p p^{-s} + \chi(p) p^{k-1-2s}} = c_p \frac{1 - \bar{b}_p p^{s-k} + \bar{\lambda}(p) p^{2s-k-1}}{1 - \bar{a}_p p^{s-k} + \bar{\chi}(p) p^{2s-k-1}}$$

with a constant c_p by Lemma 3.2.1. Let u and v be the degrees of

$$1 - a_p p^{-s} + \chi(p) p^{k-1-2s}$$

and

$$1 - b_p p^{-s} + \lambda(p) p^{k-1-2s}$$

as polynomials of p^{-s} , respectively. Then $0 \leq u, v \leq 2$. We are going to discuss each case separately. From now on we put

$$x = p^{-s}$$

and

$$M_p/N_p = p^e.$$

1° If $u = v$, then $M_p = N_p$ by (4.6.38).

2° Suppose $u = 1$ and $v = 0$. We can rewrite (4.6.38) into

$$c_p(1 - a_p x) = x^e(1 - \bar{a}_p p^{-k} x^{-1}), \quad a_p \neq 0,$$

so that $|a_p|^2 = p^k$; which contradicts Theorem 4.6.17. If $u = 0$ and $v = 1$, then we see $N_p = pM_p$.

3° Suppose $u = 2$ and $v = 0$. Then (4.6.38) can be rewritten into

$$(4.6.39) \quad c_p(1 - a_p x + \chi(p) p^{k-1} x^2) = x^e(1 - \bar{a}_p p^{-k} x^{-1} + \bar{\chi}(p) p^{-k-1} x^{-2}).$$

Comparing the degrees of both sides, we get $e = 2$ and

$$c_p \chi(p) p^{k-1} = 1, \quad c_p = \bar{\chi}(p) p^{-k-1},$$

so that $|\chi(p)|^2 = p^2$; which is a contradiction. If $u = 0$ and $v = 2$, then we see easily $e = -2$, so that $N_p = p^2 M_p$.

4° Suppose $u = 2$ and $v = 1$. We rewrite (4.6.38) into

$$(4.6.40) \quad c_p \frac{1 - a_p x + \chi(p) p^{k-1} x^2}{1 - b_p x} = x^e \frac{1 - \bar{a}_p p^{-k} x^{-1} + \bar{\chi}(p) p^{-k-1} x^{-2}}{1 - \bar{b}_p p^{-k} x^{-1}}.$$

Put $t = x^{-1}$. Then the absolute values of the roots of

$$t^2 - a_p t + \chi(p) p^{k-1} = 0$$

are $p^{(k-1)/2}$ by (4.5.41) and the absolute values of the roots of

$$\bar{\chi}(p) p^{-k-1} t^2 - \bar{a}_p p^{-k} t + 1 = \bar{\chi}(p) p^{-k-1} (t^2 - a_p p t + \chi(p) p^{k+1}) = 0$$

are $p^{(k+1)/2}$. Therefore this case cannot happen. If $u = 1$ and $v = 2$, then we also see that $N_p = pM_p$.

Consequently, in any case we obtain that $M|N$, and χ is induced by λ . Therefore Theorem 4.6.12 implies that $f(z) = g(z)$, and so $N = M$. □

This theorem combined with Corollary 4.6.14 implies

Corollary 4.6.20. *Let $f(z)$ be a nonzero element of $\mathcal{S}_k(N, \chi)$. If $f|T(n) = a_n f$ for all integers n prime to N , then there uniquely exist a divisor M of N with $m_\chi | M$ and a primitive form $g(z)$ of $\mathcal{S}_k^0(M, \chi)$ such that $g|T(n) = a_n g$ for all n prime to N . Moreover*

$$f(z) \in \langle g(lz) \mid lM | N \rangle.$$

Corollary 4.6.21. *Let $f(z) = \sum_{n=1}^\infty a_n e^{2\pi i n z}$ be a non-zero element of $\mathcal{S}_k(N, \chi)$. Then $f(z)$ is a constant multiple of a primitive form of $\mathcal{S}_k^0(N, \chi)$ if and only if $f(z)$ is a common eigenfunction of $\mathcal{R}(N)$ and $\mathcal{R}^*(N)$.*

By Theorem 4.5.5 and 4.5.16, we see

Corollary 4.6.22. *Let $f(z) = \sum_{n=1}^\infty a_n e^{2\pi i n z}$ be an element of $\mathcal{S}_k(N, \chi)$ with $a_1 = 1$, and put*

$$(f|_k \omega_N)(z) = c \sum_{n=1}^\infty b_n e^{2\pi i n z}, \quad (b_1 = 1).$$

Then $f(z)$ is a primitive form of $\mathcal{S}_k^0(N, \chi)$ if and only if $L(s, f)$ and $L(s, f|_k \omega_N)$ have the following Euler products:

$$L(s, f) = \prod_p (1 - a_p p^{-s} + \chi(p) p^{k-1-2s})^{-1},$$

$$L(s, f|_k \omega_N) = c \prod_p (1 - b_p p^{-s} + \bar{\chi}(p) p^{k-1-2s})^{-1}.$$

§4.7. Dirichlet L -Functions and Modular Forms

In §4.3, we proved that integral forms are characterized by functional equations of the associated Dirichlet series. It is natural to ask what such Dirichlet series are. We showed in §4.1 that the Dirichlet series associated with Eisenstein series with respect to $SL_2(\mathbb{Z})$ are nothing but the products of two Riemann zeta-functions. In this section, we are going to generalize this and prove that elements of $\mathcal{N}_k(N, \chi)$ correspond to the products of two Dirichlet L -functions. This was proved by Hecke by constructing modular forms explicitly using Eisenstein series. Here we start from Dirichlet series and construct modular forms as an application of Weil's theorem. We shall discuss on Eisenstein series again in Chapter 7.

Now let χ_1 and χ_2 be Dirichlet characters mod M_1 and mod M_2 , respectively. Put

$$\phi(s) = L(s, \chi_1) L(s - k + 1, \chi_2),$$

for a positive integer k . Then

$$\begin{aligned} \phi(s) &= \prod_p [(1 - \chi_1(p) p^{-s})(1 - \chi_2(p) p^{k-1} p^{-s})]^{-1} \\ &= \sum_{n=1}^\infty a_n n^{-s} \end{aligned}$$

on $\text{Re}(s) > k$. Here

$$(4.7.1) \quad a_n = \sum_{0 < d|n} \chi_1(n/d)\chi_2(d)d^{k-1}.$$

We shall prove that $\phi(s)$ is a Dirichlet series associated with a modular form under suitable conditions on χ_1 and χ_2 . Put

$$\chi = \chi_1 \chi_2$$

and

$$M = M_1 M_2.$$

Assume that $\chi(-1) = (-1)^k$ and

(4.7.2) χ_1 and χ_2 satisfy one of the following conditions:

- (i) if $k = 2$, and both χ_1 and χ_2 are trivial, then $M_1 = 1$ and M_2 is a prime number;
- (ii) otherwise, χ_1 and χ_2 are primitive characters.

First suppose that there exists an element $f(z)$ of $\mathcal{G}_k(M, \chi)$ such that $L(s; f) = \phi(s)$, and we study the constant term of $f(z)$ by the functional equation of $L(s; f)$. We put as in (4.3.12),

$$A_M(s; f) = (2\pi/\sqrt{M})^{-s} \Gamma(s) L(s; f).$$

Case (ii): Let δ_i be 0 or 1 such that $\chi_i(-1) = (-1)^{\delta_i}$, and $A(s, \chi)$ be as in Corollary 3.3.2. Then

$$(4.7.3) \quad A(s, \chi_1) A(s - k + 1, \chi_2) = 2\sqrt{\pi} (M_2/\pi)^{(1-k)/2} \mu(s)^{-1} A_M(s; f),$$

$$\mu(s) = \begin{cases} \left(\frac{s-k+1+\delta_2}{2}\right) \left(\frac{s-k+1+\delta_2}{2} + 1\right) \cdots \left(\frac{s}{2} - 1\right) & \text{if } k > 2, \delta_1 = 1, \\ \left(\frac{s-k+1+\delta_2}{2}\right) \left(\frac{s-k+1+\delta_2}{2} + 1\right) \cdots \left(\frac{s-1}{2}\right) & \text{if } k > 1, \delta_1 = 0, \\ 1 & \text{otherwise.} \end{cases}$$

Therefore $A_M(s; f)$ is holomorphic on the whole s -plane except for $s = 0$ and $s = k$, and has poles of orders at most 1 at $s = 0$ and $s = k$. More precisely, $A_M(s; f)$ is holomorphic at $s = 0$, if either

- (a) $k \neq 1$ and χ_1 is a non-trivial character,

or

- (b) $k = 1$ and both χ_1 and χ_2 are non-trivial.

In other cases, $A_M(s; f)$ has the residue $-a_0$ at $s = 0$, where

$$(4.7.4) \quad a_0 = L(1 - k, \chi)/2.$$

Case (i): Let

$$A(s) = \pi^{-s/2} \Gamma(s/2) \zeta(s)$$

with the Riemann zeta-function $\zeta(s)$ as in Theorem 3.2.2. We have

$$A(s)A(s-1) = 4\pi(s-1)^{-1}(1-M^{1-s})^{-1}M^{-s/2}A_M(s;f).$$

Hence $A_M(s;f)$ is holomorphic on the whole s -plane except for $s=0$ and $s=2$, and has simple poles at $s=0$ and $s=2$. The residue at $s=0$ is given by $-a_0$, where

$$(4.7.5) \quad a_0 = -(1-M)\zeta(-1)/2.$$

Thus we have determined the expected constant term a_0 of $f(z)$.

Theorem 4.7.1. *Let χ_1 and χ_2 be Dirichlet characters mod M_1 and mod M_2 , respectively, satisfying (4.7.2). Put $M = M_1M_2$ and $\chi = \chi_1\chi_2$. Then for a positive integer k such that $\chi(-1) = (-1)^k$, there exists an element $f(z)$ of $\mathcal{G}_k(M, \chi)$ such that*

$$L(s;f) = L(s, \chi_1)L(s-k+1, \chi_2).$$

Moreover if we write $f(z) = \sum_{n=0}^{\infty} a_n e^{2\pi inz}$, then

$$a_0 = \begin{cases} 0, & \text{if } k \neq 1, \text{ and } \chi_1 \text{ is non-trivial} \\ & \text{or if both } \chi_1 \text{ and } \chi_2 \text{ are non-trivial,} \\ -\frac{1}{24}(1-M), & \text{if } k = 2, \text{ and both } \chi_1 \text{ and } \chi_2 \text{ are trivial,} \\ -B_{k,\chi}/2k, & \text{otherwise,} \end{cases}$$

and

$$a_n = \sum_{0 < d|n} \chi_1(n/d)\chi_2(d)d^{k-1} \quad (n \geq 1).$$

Proof. Let a_n ($n \geq 0$) be as in the theorem. Then

$$L(s, \chi_1)L(s-k+1, \chi_2) = \sum_{n=1}^{\infty} a_n n^{-s}.$$

We put

$$(4.7.6) \quad f(z) = f_k(z; \chi_1, \chi_2) = \sum_{n=0}^{\infty} a_n e^{2\pi inz}.$$

By Lemma 4.3.3, $f(z)$ satisfies (4.3.7). Using Weil's theorem (Theorem 4.3.15) we shall prove that $f(z)$ is an element of $\mathcal{G}_k(M, \chi)$. Let ψ be any primitive Dirichlet character whose conductor m is prime to M , and $L(s;f, \psi)$ the Dirichlet series defined by (4.3.18). Then

$$(4.7.7) \quad L(s;f, \psi) = L(s, \chi_1\psi)L(s-k+1, \chi_2\psi).$$

First we consider case (ii) of (4.7.2). Putting $\delta'_i = \delta_{\chi_i\psi}$ ($i = 1, 2$) (cf. (3.3.15) and Corollary 3.3.2), we see that

$$(4.7.8) \quad A(s, \chi_1\psi)A(s-k+1, \chi_2\psi) = 2\sqrt{\pi} \left(\frac{mM_2}{\pi} \right)^{(1-k)/2} \mu(s)^{-1} A_M(s;f, \psi),$$

where

(4.7.9)

$$\mu(s) = \begin{cases} \left(\frac{s-k+1+\delta'_2}{2}\right)\left(\frac{s-k+1+\delta'_2}{2}+1\right)\cdots\left(\frac{s}{2}-1\right) & \text{if } k > 2, \delta'_1 = 1, \\ \left(\frac{s-k+1+\delta'_2}{2}\right)\left(\frac{s-k+1+\delta'_2}{2}+1\right)\cdots\left(\frac{s-1}{2}\right) & \text{if } k > 1, \delta'_1 = 0, \\ 1 & \text{otherwise.} \end{cases}$$

We put

$$(4.7.10) \quad g(z) = Cf(z; \bar{\chi}_2, \bar{\chi}_1),$$

where

$$(4.7.11) \quad C = (-1)^k \frac{W(\chi_1)W(\chi_2)}{\sqrt{M}} (M_1/M_2)^{(1-k)/2}.$$

The functional equations of $\Lambda(s, \chi_1\psi)$ and $\Lambda(s, \chi_2\psi)$ combined with (4.7.8) imply the functional equation

$$(4.7.12) \quad \Lambda_M(s; f, \psi) = i^k C_\psi \Lambda_M(k-s; g, \bar{\psi}),$$

where

$$C_\psi = \frac{W(\psi)^2 \chi(m)\psi(M)}{m} = \chi(m)\psi(-M) \frac{W(\psi)}{W(\bar{\psi})}.$$

Therefore $f(z) \in \mathcal{G}_k(M, \chi)$ by Theorem 4.3.15. Next we consider case (i). Then

$$(4.7.13) \quad \begin{aligned} \Lambda(s, \psi)\Lambda(s-1, \bar{\psi}) \\ = 2\sqrt{\pi}(m/\pi)^{-1/2} \mu(s)^{-1} (1-\psi(M)M^{1-s})^{-1} M^{-s/2} \Lambda_M(s; f, \psi), \end{aligned}$$

where

$$(4.7.14) \quad \mu(s) = \begin{cases} 1 & \text{if } \psi(-1) = -1, \\ \frac{s-1}{2} & \text{if } \psi(-1) = 1. \end{cases}$$

By the functional equation of $\Lambda(s, \psi)$, we obtain the functional equation

$$(4.7.15) \quad \Lambda_M(s; f, \psi) = -C_\psi \Lambda_M(2-s; -f, \bar{\psi}).$$

Thus $f(z) \in \mathcal{G}_2(M, \chi)$. □

Hereafter we fix a positive integer k , and let $f_k(z; \chi_1, \chi_2)$ be the modular form $f(z)$ defined by (4.7.6). By Theorem 4.5.16, we note that

$$(4.7.16) \quad f_k(z; \chi_1, \chi_2) \text{ is a common eigenfunction of } {}^M T(n) \text{ for all } n \geq 1.$$

For a Dirichlet character χ mod N satisfying $\chi(-1) = (-1)^k$, we put

$$(4.7.17) \quad \mathcal{E}_k(N, \chi) = \langle f_k(lz; \chi_1, \chi_2) \mid lM_1M_2 \mid N, \chi_1\chi_2 = \chi, \text{ and } \chi_1 \text{ and } \chi_2 \text{ satisfy (4.7.2)} \rangle.$$

We note that $\mathcal{E}_k(N, \chi)$ is stable by $T(n)$ ($(n, N) = 1$) and generated by common eigenfunctions of $T(n)$ ($(n, N) = 1$) by (4.7.16).

Theorem 4.7.2. $\mathcal{E}_k(N, \chi) = \mathcal{N}_k(N, \chi)$.

Proof. First we show that $\mathcal{E}_k(N, \chi) \subset \mathcal{N}_k(N, \chi)$. Let $g(z) \in \mathcal{E}_k(N, \chi)$ be a common eigenfunction of all $T(n)$ ($(n, N) = 1$) with eigenvalue t_n . Since

$$\mathcal{G}_k(N, \chi) = \mathcal{S}_k(N, \chi) \oplus \mathcal{N}_k(N, \chi),$$

we can write

$$g = g_1 + g_2, \quad (g_1 \in \mathcal{S}_k(N, \chi), \quad g_2 \in \mathcal{N}_k(N, \chi)).$$

By Corollary 2.8.4 and Theorem 4.5.18, $\mathcal{S}_k(N, \chi)$ and $\mathcal{N}_k(N, \chi)$ are stable by $T(n)$. Therefore $g_1 \mid T(n) \in \mathcal{S}_k(N, \chi)$, and hence,

$$g_1 \mid T(n) = t_n g_1.$$

Now there exists $f(z) = f_k(z; \chi_1, \chi_2)$ which has the same eigenvalues of $T(n)$ as those for $g(z)$ for all n prime to N . On the other hand, by Corollary 4.6.14, there exist a divisor N' of N and a primitive form $h(z)$ of $\mathcal{S}_k(N', \chi)$ such that $g_1(z)$, $h(z)$ and $g(z)$ have the same eigenvalues for $T(n)$ ($(n, N) = 1$). Therefore $L(s; f)$ and $L(s; h)$ has the same Euler factors for all prime numbers prime to N . First assume that χ_2 is trivial. Then

$$\Gamma(s)L(s, \chi_1)L(s - k + 1, \chi_2)$$

has a simple pole at $s = k$. Since $h(z)$ is a cusp form, $\Gamma(s)L(s; h)$ is an entire function. Put

$$L(s; h) = \sum_{n=1}^{\infty} a_n n^{-s},$$

then

$$\frac{\Gamma(s)L(s, \chi_1)L(s - k + 1, \chi_2)}{\Gamma(s)L(s; h)} = \prod_{p \mid N} \frac{1 - a_p p^{-s} + \chi(p)p^{k-1-2s}}{(1 - \chi_1(p)p^{-s})(1 - \chi_2(p)p^{k-1-s})},$$

and it has a pole at $s = k$. This is impossible from the form of the right-hand side. Next suppose that χ_2 is not trivial. Then by taking the twisted modular form $g_{\bar{z}}$ in place of g , a similar argument is applicable. Consequently we obtain $g_1 = 0$ or $g \in \mathcal{N}_k(N, \chi)$. To prove that $\mathcal{E}_k(N, \chi) = \mathcal{N}_k(N, \chi)$, we shall calculate the dimension of $\mathcal{E}_k(N, \chi)$.

1° The case when either $k > 2$ or $k = 2$ and χ is non-trivial. Let us show that $f_k(lz; \chi_1, \chi_2)$'s are linearly independent. Let

$$\sum_{l, \chi_1, \chi_2} c(l, \chi_1, \chi_2) f_k(lz; \chi_1, \chi_2) = 0, \quad (c(l, \chi_1, \chi_2) \in \mathbb{C}).$$

Here l runs over all positive integers such that $lM \mid N$, and χ_1 and χ_2 run over all

Dirichlet characters such that $\chi_1 \chi_2 = \chi$. Put

$$L(s, \chi_1)L(s - k + 1, \chi_2) = \sum_{n=1}^{\infty} a_n(\chi_1, \chi_2)n^{-s}.$$

Then $a_n(\chi_1, \chi_2)$ is the eigenvalue of $T(n)$ for $f_k(lz; \chi_1, \chi_2)$ provided n is prime to N . Moreover if $a_n(\chi_1, \chi_2) = a_n(\psi_1, \psi_2)$ for all n prime to N , then $\chi_1 = \psi_1$ and $\chi_2 = \psi_2$. Therefore, for any fixed pair (χ_1, χ_2) , we see

$$(4.7.18) \quad \sum_l c(l, \chi_1, \chi_2) f_k(lz; \chi_1, \chi_2) = 0.$$

Since the first Fourier coefficient of $f_k(z; \chi_1, \chi_2)$ is equal to 1, we get $c(l, \chi_1, \chi_2) = 0$ for all l . This proves the linear independence of $f_k(lz; \chi_1, \chi_2)$. In particular,

$$\dim \mathcal{E}_k(N, \chi) = \# \{ (l, \chi_1, \chi_2) \mid lM_1M_2 \mid N, \chi_1, \chi_2 \text{ are primitive and } \chi_1 \chi_2 = \chi \}.$$

The set of the right-hand side corresponds bijectively to the set of pairs (χ'_1, χ'_2) of (not necessarily primitive) Dirichlet characters

$$\{ (\chi'_1, \chi'_2) \mid \chi'_1 \chi'_2 = \chi, \quad M'_1 M'_2 = N \},$$

where χ'_i is defined mod M'_i . The correspondence is given by

$$(l, \chi_1, \chi_2) \mapsto (\chi'_1, \chi'_2),$$

where

χ'_1 = the Dirichlet character defined mod lM_1 induced by χ_1 ,

χ'_2 = the Dirichlet character defined mod N/lM_1 induced by χ_2 .

Thus we obtain

$$\dim \mathcal{E}_k(N, \chi) = \# \{ (\chi_1, \chi_2) \mid \chi_1 \chi_2 = \chi, \quad M_1 M_2 = N \}.$$

2° The case when $k = 2$ and χ is the trivial character. Then $N > 1$. By a similar argument as in 1°, $f_k(lz; \chi_1, \chi_2)$ are linearly independent, and

$\dim \mathcal{E}_2(N, \chi) = \# \{ (\chi_1, \chi_2) \mid \chi_1 \chi_2 = \chi, \quad M_1 M_2 = N, \text{ and if } \chi_2 = \chi, \text{ then } M_2 \neq 1 \}.$

3° The case when $k = 1$. If $\mathcal{G}_1(N, \chi) \neq \{0\}$, then $N \geq 3$ and $\chi(-1) = -1$. Since $f_k(z; \chi_1, \chi_2) = f_k(z; \psi_1, \psi_2)$ if and only if $\{\chi_1, \chi_2\} = \{\psi_1, \psi_2\}$, we obtain

$$\dim \mathcal{E}_1(N, \chi) = \frac{1}{2} \# \{ (\chi_1, \chi_2) \mid \chi_1 \chi_2 = \chi, \quad M_1 M_2 = N \}$$

by a similar argument as in 1°.

Now we put

$$(4.7.19) \quad \mathcal{E}_k(\Gamma_1(N)) = \bigoplus_{\chi} \mathcal{E}_k(N, \chi),$$

where χ runs over all Dirichlet characters mod N satisfying $\chi(-1) = (-1)^k$. Then by Theorem 2.1.7,

$$\mathcal{E}_k(\Gamma_1(N)) \subset \mathcal{N}_k(\Gamma_1(N)).$$

From 1°, 2° and 3°, we see

$$\dim \mathcal{E}_k(\Gamma_1(N)) = \begin{cases} \frac{1}{2} \sum_{M|N} \phi(M)\phi(N/M), & \text{if } k \geq 3, N \geq 3, N \neq 4, \\ \frac{1}{2} \sum_{M|N} \phi(M)\phi(N/M) - 1, & \text{if } k = 2, N \geq 3, N \neq 4, \\ \frac{1}{4} \sum_{M|N} \phi(M)\phi(N/M), & \text{if } k = 1, N \geq 3, N \neq 4, \\ 3 & \text{if } N = 4, k(\text{even}) \geq 4, \\ 2 & \text{if } N = 4, k(\text{odd}) \geq 3 \text{ or } k = 2; \\ & N = 2, k(\text{even}) \geq 4, \\ 1 & \text{if } N = 4, k = 1; N = 2, k = 2; \\ & N = 1, k(\text{even}) \geq 4, \\ 0 & \text{otherwise} \end{cases}$$

where ϕ is the Euler function. Therefore by Theorem 2.1.7(1), Theorem 4.2.9 and Theorem 2.5.2, $\dim \mathcal{E}_k(\Gamma_1(N)) = \dim \mathcal{N}_k(\Gamma_1(N))$. This implies $\mathcal{E}_k(\Gamma_1(N)) = \mathcal{N}_k(\Gamma_1(N))$, and therefore, $\mathcal{E}_k(N, \chi) = \mathcal{N}_k(N, \chi)$. \square

Using explicit Fourier expansions (4.7.1), we obtain the following estimate of Fourier coefficients of any element of $\mathcal{E}_k(N, \chi)$.

Theorem 4.7.3. *Let $f(z) = \sum_{n=0}^{\infty} a_n e^{2\pi i n z}$ be an element of $\mathcal{E}_k(N, \chi)$. Then*

$$a_n = \begin{cases} O(n^{k-1}), & \text{if } k > 2, \\ O(n^{k-1+\varepsilon}), & \text{if } k = 1, 2, \end{cases}$$

for any $\varepsilon > 0$.

Proof. For an integer n , we put

$$(4.7.20) \quad \sigma_{k-1}(n) = \sum_{0 < d|n} d^{k-1}.$$

If $k - 1 \geq 2$, then

$$\sigma_{k-1}(n) = n^{k-1} \sum_{0 < d|n} d^{1-k} < n^{k-1} \zeta(k-1),$$

so that

$$\sigma_{k-1}(n) = O(n^{k-1}).$$

If $k = 2$, then

$$\sigma_1(n) = n \sum_{0 < d|n} d^{-1} < n \sum_{l=1}^n l^{-1} < n(1 + \log n),$$

so that

$$\sigma_1(n) = O(n^{1+\varepsilon})$$

for any $\varepsilon > 0$. Suppose $k = 1$. Since $\sigma_0(n)$ is equal to the number of all the positive divisors of n , we have

$$(4.7.21) \quad \frac{\sigma_0(n)}{n^\varepsilon} = \prod_i \left(\frac{a_i + 1}{p_i^{a_i \varepsilon}} \right), \quad \left(n = \prod_i p_i^{a_i} \right)$$

for $\varepsilon > 0$. Since

$$a\varepsilon \log 2 \leq 2^{a\varepsilon} \leq p^{a\varepsilon}$$

for any positive integer a , we see

$$(4.7.22) \quad \frac{a+1}{p^{a\varepsilon}} \leq 1 + \frac{a}{p^{a\varepsilon}} \leq 1 + \frac{1}{\varepsilon \log 2} \leq e^{1/\varepsilon \log 2}.$$

If $p \geq 2^{1/\varepsilon}$, then $p^\varepsilon \geq 2$, so that

$$(4.7.23) \quad \frac{a+1}{p^{a\varepsilon}} \leq \frac{a+1}{2^a} \leq 1.$$

By (4.7.22) or (4.7.23) according as $p_i < 2^{1/\varepsilon}$ or not, we see

$$\frac{\sigma_0(n)}{n^\varepsilon} \leq \prod_{p_i < 2^{1/\varepsilon}} e^{1/\varepsilon \log 2} \leq \exp(2^{1/\varepsilon}/\varepsilon \log 2),$$

so that

$$\sigma_0(n) = O(n^\varepsilon).$$

These results combined with (4.7.1) prove the assertion. \square

Let us consider the special case when $N = 1$ and $\chi_1 = \chi_2 = \chi_0$ (the principal character). Assume $k \geq 4$. From the remark mentioned at the end of §4.1, we see

$$f_k(z; \chi_0, \chi_0) = cE_k(z) \quad (c = (k-1)!/2(2\pi i)^k),$$

where $E_k(z)$ is the Eisenstein series defined by (4.1.3). Even if $N > 1$, it is known that if $k \geq 3$, then $f_k(z; \chi_1, \chi_2)$ can be expressed as a linear combination of series similarly defined as $E_k(z)$. In the case when $k = 1$ or 2 , a modification is necessary. Eisenstein series will be explained in §7.1 and §7.2 again.

§4.8. L -Functions of Quadratic Fields and Cusp Forms

In the previous section, we showed that $\mathcal{N}_k(N, \chi)$ is generated by modular forms associated with products of two Dirichlet L -functions. It is natural to ask what kind of Dirichlet series are associated with cusp forms. If an L -function of a number field corresponds to a cusp form, then the field must be a quadratic field from the forms of the Euler products. Let K be a quadratic field, and ξ a Hecke character of K with u_v, v_v defined by (3.3.1). Assume that $L(s - (k-1)/2, \xi)$ corresponds to some cusp form. Then we see

(i) K is imaginary,

or

(ii) K is real, and $v_v = 0$ ($v = 1, 2$), $u = u_1 + u_2 = 1$,

by comparing Γ -factors which appear in the functional equations in Theorem 3.3.1 and Corollary 4.3.7. Here we use the same notation as in §3.3. Under the above situation, Hecke proved that $L(s - (k-1)/2, \xi)$ corresponds to a cusp form by

using theta functions which we shall discuss in the next section. We are, however, going to prove this again by Weil's theorem.

Let $K = \mathbb{Q}(\sqrt{d})$ be a quadratic field with discriminant d , p a prime number with $(p, d) = 1$, and ψ a primitive Dirichlet character of conductor p . We denote by \mathfrak{r} and I the ring of integers and the group of fractional ideals of K , respectively. We define the Hecke character $\psi \circ N_K$ by

$$(4.8.1) \quad (\psi \circ N_K)(\mathfrak{a}) = \psi(N_K(\mathfrak{a})) \quad (\mathfrak{a} \in I),$$

where N_K is the norm mapping of I into \mathbb{Q}^\times . We note $\psi \circ N_K$ is a primitive character of conductor pt .

Lemma 4.8.1. *Let $\chi_d = \left(\frac{d}{\cdot}\right)$ be the Kronecker symbol.*

- (1) $W(\chi_d) = \begin{cases} \sqrt{d} & \text{if } d > 0, \\ i\sqrt{|d|} & \text{if } d < 0. \end{cases}$
- (2) *If $(d, p) = 1$, then $W(\psi \circ N_K) = \chi_d(p)\psi(|d|)W(\psi)^2$.*

Proof. We use the notation in Theorem 3.3.1. Since

$$\zeta_K(s) = \zeta(s)L(s, \chi_d),$$

we get

$$T(\chi_d) = 1$$

by comparing the functional equations of both sides. Since $\chi_d(-1) = 1$ or -1 if K is real or imaginary, respectively, this implies (1). Since

$$L(s, \psi \circ N_K) = L(s, \psi)L(s, \psi\chi_d),$$

we obtain

$$T(\psi \circ N_K) = T(\psi)T(\psi\chi_d).$$

This combined with Lemma 3.1.2 and (1) implies (2). □

Theorem 4.8.2. *Let $K = \mathbb{Q}(\sqrt{d})$ be an imaginary quadratic field with discriminant d , and ξ a Hecke character mod \mathfrak{n} such that*

$$\xi((\mathfrak{a})) = (a/|a|)^u \quad (a \equiv 1 \pmod{\mathfrak{n}})$$

with a non-negative integer u . We put

$$f(z) = f(z; \xi) = \sum_{\mathfrak{a}} \xi(\mathfrak{a})N_K(\mathfrak{a})^{u/2} e^{2\pi i N_K(\mathfrak{a})z},$$

where \mathfrak{a} runs over all integral ideals of K . Then $f(z) \in \mathcal{G}_{u+1}(N, \chi)$ and further

$$f(z) \in \mathcal{S}_{u+1}(N, \chi),$$

unless $u = 0$ and ξ is induced from a Dirichlet character through N_K . Here $N = |d|N_K(\mathfrak{n})$, and χ is a Dirichlet character defined by

$$\chi(m) = \chi_d(m)\xi((m))\text{sgn}(m)^n \quad (M \in \mathbb{Z}).$$

Moreover if ξ is primitive, then $f(z)$ is a primitive form.

Proof. Let \mathfrak{p} be a prime ideal. If ξ' is the character mod $\mathfrak{p}n$ induced by ξ . Then

$$f(z, \xi') = \overline{f(z, \xi)} - \xi(\mathfrak{p})N_{\mathfrak{k}}(\mathfrak{p})^{u/2} f(N_{\mathfrak{k}}(\mathfrak{p})z; \xi).$$

Therefore we have only to prove the theorem for a primitive character ξ . By definition, $L(s; f) = L(s - u/2, \xi)$. Let ψ be a primitive Dirichlet character of prime conductor p . Suppose $(p, N) = 1$. Then since $L(s; f, \psi) = L(s - u/2, \xi(\psi \circ N_{\mathfrak{k}}))$, we see from Theorem 3.3.1 and Lemma 4.8.1 that

$$\begin{aligned} A_N(s; f, \psi) &= (p\sqrt{N}/2\pi)^s \Gamma(s) L(s - u/2, \xi(\psi \circ N_{\mathfrak{k}})) \\ &= (p\sqrt{N}/2\pi)^{u/2} \Lambda(s - u/2, \xi(\psi \circ N_{\mathfrak{k}})) \\ &= (p\sqrt{N}/2\pi)^{u/2} i^{-u} \frac{\xi((p))\chi_a(p)\psi(N)W(\xi)W(\psi)^2}{pN_{\mathfrak{k}}(n)^{1/2}} \\ &\quad \times \Lambda(1 + u/2 - s, \bar{\xi}(\bar{\psi} \circ N_{\mathfrak{k}})) \\ &= i^{u+1} C_{\psi} A_N(1 + u - s; g, \bar{\psi}), \end{aligned}$$

where

$$\begin{aligned} C_{\psi} &= \frac{\chi(p)\psi(N)W(\psi)^2}{p} = \chi(p)\psi(-N) \frac{W(\psi)}{W(\bar{\psi})}, \\ g(z) &= i^{-2u-1} \frac{W(\xi)}{N_{\mathfrak{k}}(n)^{1/2}} \sum_{\mathfrak{a}} \bar{\xi}(\mathfrak{a}) N_{\mathfrak{k}}(\mathfrak{a})^{u/2} e^{2\pi i N_{\mathfrak{k}}(\mathfrak{a})z}. \end{aligned}$$

Therefore Theorem 4.3.15 implies that $f(z) \in \mathcal{G}_{u+1}(N, \chi)$, and $f(z)$ is a cusp form if $u > 0$, since $L(s; f)$ is convergent for $\text{Re}(s) > (u + 2)/2$. Since $L(s; f)$ has obviously the Euler product of the form in Theorem 4.5.16, $f(z)$ is a common eigenfunction of all $T(n)$. Assume that $u = 0$ and $f(z)$ is not a cusp form. Since $f(z)$ is a common eigenfunction of Hecke operators,

$$L(s; f) = L(s, \chi_1)L(s, \chi_2)$$

with Dirichlet characters χ_1, χ_2 by the proof of Theorem 4.7.2. But this can happen only when ξ is induced from a Dirichlet character. The last part of the assertion is obvious from Corollary 4.6.22. \square

For a real quadratic field K , a similar argument is applicable and we obtain

Theorem 4.8.3. *Let $K = \mathbb{Q}(\sqrt{d})$ be a real quadratic field with discriminant d , and ξ a Hecke character mod n such that*

$$\xi((a)) = a/|a| = \text{sgn}(a) \quad (a \equiv 1 \pmod{n}),$$

or

$$\xi((a)) = a'/|a'| = \text{sgn}(a') \quad (a \equiv 1 \pmod{n}),$$

where a' is the conjugate of a over \mathbb{Q} . We put

$$f(z) = f(z; \xi) = \sum_{\mathfrak{a}} \xi(\mathfrak{a}) e^{2\pi i N_{\mathfrak{k}}(\mathfrak{a})z},$$

where a runs over all integral ideals of K . Then

$$f(z) \in \mathcal{S}_1(N, \chi),$$

where $N = dN_K(\mathfrak{n})$, and χ is a Dirichlet character defined by

$$\chi(m) = \chi_a(m)\xi((m)) \quad (m \in \mathbb{Z}).$$

Furthermore if ξ is primitive, then $f(z)$ is a primitive form.

Hereafter we assume that readers are familiar with Artin L -functions. Let us consider a special case when ξ in Theorem 4.8.2 and Theorem 4.8.3 is a class character. Then K is a real quadratic field or K is an imaginary quadratic field and $\xi((a)) = 1$ provided $a \equiv 1 \pmod{\mathfrak{n}}$. Let J be the subgroup of I defined by

$$J = \{a \in I \mid \xi(a) = 1\}.$$

Let M be the abelian extension of K corresponding to J , and L the minimal Galois extension of \mathbb{Q} containing M . Then

$$G(L/K)/G(L/M) \simeq G(M/K) \simeq I(\mathfrak{n})/J,$$

where $G(L/K)$ indicates the Galois group of an extension L/K , and

$$I(\mathfrak{n}) = \{a \in I \mid (a, \mathfrak{n}) = 1\}.$$

Therefore ξ induces a character $\tilde{\xi}$ of $G(L/K)$. Let ρ be a representation of $G(L/\mathbb{Q})$ induced by $\tilde{\xi}$. Then we have

$$L(s, \rho) = L(s, \xi),$$

so that $L(s, \xi)$ is an Artin L -function over \mathbb{Q} . In other words, such an Artin L -function $L(s, \rho)$ corresponds to a cusp form of weight 1. Therefore we may expect that there exists a correspondence between cusp forms of weight 1 and Artin L -functions associated with irreducible representations of degree 2 of Galois groups over \mathbb{Q} . Indeed, [Deligne–Serre] proved that cusp forms of weight 1 always correspond to such Artin L -functions. Conversely, it can be shown similarly to the above theorems that certain Artin L -functions satisfy functional equations of the type required in Weil’s theorem. Therefore the above conjecture is equivalent to the Artin conjecture for such Artin L -functions.

§4.9. Theta Functions

In §2.6, §4.7 and §4.8, we constructed modular forms by using Poincaré series or Dirichlet series. In this section, we give another way of constructing modular forms which is a generalization of the theta function defined by (3.2.16). The advantage of theta functions is that we can explicitly calculate Fourier coefficients of modular forms. Furthermore, theta functions play essential roles in the theory of quadratic forms. Throughout this section, we put

$$e(z) = e^{2\pi iz}.$$

Let A be a symmetric matrix of size r over \mathbb{Z} . Assume that A is *positive definite*, namely, all the eigenvalues of A are positive. We put

$$A[x] = {}^t xAx$$

for a column vector x of size r , and put formally

$$f(z) = \sum_{m \in \mathbb{Z}^r} e(A[m]z) \quad (z \in \mathbf{H}).$$

Hereafter we consider all elements of \mathbb{C}^r , \mathbb{R}^r , \mathbb{Z}^r etc., as column vectors. For a non-negative integer n , we put

$$a(n, A) = \#\{m \in \mathbb{Z}^r \mid A[m] = n\}.$$

Then

$$f(z) = \sum_{n=0}^{\infty} a(n, A) e^{2\pi i n z}.$$

We shall show that $f(z)$ is convergent and is an integral form provided r is even. This gives an effective method of constructing integral forms. By this fact, we obtain an estimate of $a(n, A)$ from that of Fourier coefficients of modular forms. The aim of this section is to prove that $f(z)$, defined as above, is a modular form. We begin by defining theta functions from quadratic forms and studying the transformation formulae. The discussion below follows [Shimura 7].

We now define the differential operator Δ_A by

$$\Delta_A = \sum_{i,j=1}^r b_{ij} \partial^2 / \partial x_i \partial x_j, \quad A^{-1} = [b_{ij}].$$

Let $P(x)$ be a homogeneous polynomial of degree ν with complex coefficients in variables x_1, \dots, x_r . We call $P(x)$ a *spherical function of degree ν with respect to A* if

$$\Delta_A P(x) = 0.$$

It is known that any spherical function of degree ν is given by

$$P(x) = \begin{cases} \text{a constant} & (\nu = 0), \\ {}^t qAx \quad (q \in \mathbb{C}^r) & (\nu = 1), \\ \text{a linear combination of } ({}^t qAx)^\nu \quad (q \in \mathbb{C}^r, A[q] = 0) & (\nu > 1). \end{cases}$$

We take an element $h \in \mathbb{Z}^r$ and a positive integer N satisfying

$$(4.9.1) \quad NA^{-1} \in M_r(\mathbb{Z});$$

$$(4.9.2) \quad Ah \in N\mathbb{Z}^r.$$

For the above A , N , h , and a spherical function $P(x)$ of degree ν with respect to A , we put for $z \in \mathbf{H}$

$$(4.9.3) \quad \begin{aligned} \theta(z; h, A, N, P) &= \sum_{\substack{m \equiv h \pmod{N} \\ m \in \mathbb{Z}^r}} P(m) e\left(\frac{A[m]}{2N^2} z\right) \\ &= \sum_{n=0}^{\infty} a(n, h, A, N, P) e\left(\frac{n}{2N^2} z\right) \end{aligned}$$

where

$$a(n, h, A, N, P) = \sum_{\substack{A[m] = n \\ m \equiv h \pmod{N}}} P(m).$$

Since A is positive definite, there exist positive numbers c_1 and c_2 satisfying

$$(4.9.4) \quad c_1 {}^t x x \leq A[x] \leq c_2 {}^t x x, \quad \text{for all } x \in \mathbb{R}^r.$$

Furthermore by Schwarz's inequality, there exists $c_3 > 0$ such that

$$(4.9.5) \quad |P(x)| \leq c_3 ({}^t x x)^{v/2}, \quad \text{for all } x \in \mathbb{R}^r.$$

Therefore

$$\sum_{\substack{A[m] = n \\ m \equiv h \pmod{N}}} |P(m)| = O(n^{(r+v)/2}).$$

Hence by Lemma 4.3.3, $\theta(z; h, A, N, P)$ is convergent absolutely and uniformly on any compact subset of \mathbf{H} and is holomorphic on \mathbf{H} . We call it a *theta function*. We put

$$D = \det(A), \quad k = r/2 + v.$$

Lemma 4.9.1. (The transformation formula)

$$\theta(-1/z; h, A, N, P) = (-i)^v D^{-1/2} (-iz)^k \sum_{\substack{Al \equiv 0 \pmod{N} \\ l \in \mathbb{Z}^r / N\mathbb{Z}^r}} e({}^t l A h / N^2) \theta(z; l, A, N, P).$$

Proof. This is a generalization of (3.2.17), and is also proved by using the Poisson summation formula. For $x \in \mathbb{R}^r$ and $z \in \mathbf{H}$, we put

$$(4.9.6) \quad \theta(z, x) = \sum_{m \in \mathbb{Z}^r} e\left(\frac{A[m+x]}{2} z\right),$$

and

$$f(x) = e\left(\frac{A[x]}{2} z\right).$$

We denote by $\hat{f}(u)$ the Fourier transform of $f(x)$. Then

$$\hat{f}(u) = D^{-1/2} (z/i)^{-r/2} e(-A^{-1}[u]/2z),$$

and by (4.9.4), we can apply the Poisson summation formula and obtain

$$(4.9.7) \quad \begin{aligned} \theta(z, x) &= \sum_{m \in \mathbb{Z}^r} \hat{f}(m) e({}^t m x) \\ &= D^{-1/2} (z/i)^{-r/2} \sum_{m \in \mathbb{Z}^r} e(-A^{-1}[m]/2z + {}^t m x). \end{aligned}$$

We have only to prove the assertion for $P(x) = ({}^t q A x)^v$ ($q \in \mathbb{C}^r$). Let $q = (q_1, \dots, q_r)$ and define the differential operator L by

$$L = \sum_{i=1}^r q_i \partial / \partial x_i.$$

Acting L^ν on both sides of (4.9.7), we see

$$\begin{aligned}
 (4.9.8) \quad & \sum_{m \in \mathbb{Z}^r} P(m+x)e\left(\frac{A[m+x]}{2}z\right) \\
 &= (-i)^\nu D^{-1/2}(z/i)^{-r/2-\nu} \sum_{m \in \mathbb{Z}^r} ({}^tqm)^\nu e(-A^{-1}[m]/2z + {}^t mx) \\
 &= (-i)^\nu D^{-1/2}(z/i)^{-k} \sum_{m \in \mathbb{Z}^r} P(A^{-1}m)e(-A^{-1}[m]/2z + {}^t mx).
 \end{aligned}$$

This is justified by the uniform convergence of $\theta(z; h, A, N, P)$ on any compact subset of \mathbf{H} . Note that if $\nu > 1$, then

$$L^2 A[x] = {}^t q A q = 0.$$

Put $x = N^{-1}h$, and take $-1/z$ in place of z . Then the left-hand side is nothing but $N^{-\nu}\theta(-1/z; h, A, N, P)$. Put $n = NA^{-1}m$. Then $m \in \mathbb{Z}^r$ if and only if $n \in \mathbb{Z}^r$ and $An \equiv 0 \pmod N$. Thus we see

$$\begin{aligned}
 & \theta(-1/z; h, A, N, P) \\
 &= (-i)^\nu D^{-1/2}(-iz)^k \sum_{\substack{An \equiv 0 \pmod N \\ n \in \mathbb{Z}^r}} P(n)e((A[n]/2N^2)z + {}^t nAh/N^2).
 \end{aligned}$$

Since $e({}^t nAh/N^2)$ is determined by the class of $n \pmod N$, we see

$$\begin{aligned}
 &= (-i)^\nu D^{-1/2}(-iz)^k \sum_{\substack{Al \equiv 0 \pmod N \\ l \in \mathbb{Z}^r/N\mathbb{Z}^r}} e({}^t lAh/N^2) \sum_{n \equiv l \pmod N} P(n)e((A[n]/2N^2)z) \\
 &= (-i)^\nu D^{-1/2}(-iz)^k \sum_{\substack{Al \equiv 0 \pmod N \\ l \in \mathbb{Z}^r/N\mathbb{Z}^r}} e({}^t lAh/N^2)\theta(z; l, A, N, P). \quad \square
 \end{aligned}$$

Hereafter we fix $P(x)$ and write simply $\theta(z; h, A, N)$ in place of $\theta(z; h, A, N, P)$. The following equalities are obvious by definition:

$$(4.9.9) \quad \theta(z; h, A, N) = \sum_{\substack{g \equiv h \pmod N \\ g \in \mathbb{Z}^r/cN\mathbb{Z}^r}} \theta(cz; g, cA, cN)$$

for any positive integer c ;

$$(4.9.10) \quad \theta(z+2; h, A, N) = e(A[h]/N^2)\theta(z; h, A, N);$$

$$(4.9.11) \quad \theta(z; -h, A, N) = (-1)^\nu \theta(z; h, A, N).$$

Now let $\delta = \begin{bmatrix} a & b \\ c & d \end{bmatrix} \in SL_2(\mathbb{Z})$. Suppose that $c > 0$ and $a \equiv d \equiv 0 \pmod 2$. Since $c\delta z = a - (cz+d)^{-1}$, we obtain by applying (4.9.9), (4.9.10) and Lemma 4.9.1

$$\begin{aligned}
 & \theta(\delta z; h, A, N) \\
 &= (-i)^\nu D^{-1/2}c^{-r/2}(-i(cz+d))^k \sum_{\substack{Al \equiv 0 \pmod N \\ l \in \mathbb{Z}^r/cN\mathbb{Z}^r}} \Phi(h, l)\theta(cz; l, cA, cN),
 \end{aligned}$$

where

$$\Phi(h, l) = \sum_{\substack{g \equiv h \pmod{N} \\ g \in \mathbb{Z}'/cN\mathbb{Z}'}} e((aA[g] + 2^l lAg + dA[l])/2cN^2).$$

Since we can express it as

$$\Phi(h, l) = e(-b(dA[l] + 2^l lAh)/2N^2)\Phi(h + dl, 0),$$

it is determined by the class of $l \pmod{N}$. Therefore it follows from (4.9.9) that

$$\begin{aligned} &\theta(\delta z; h, A, N) \\ &= (-i)^{\nu} D^{-1/2} c^{-r/2} (-i(cz + d))^k \sum_{\substack{Al \equiv 0 \pmod{N} \\ l \in \mathbb{Z}'/N\mathbb{Z}'}} \Phi(h, l)\theta(z; l, A, N). \end{aligned}$$

Replacing z with $-1/z$, and applying Lemma 4.9.1, we see that

$$\begin{aligned} &\theta\left(\frac{bz - a}{dz - c}; h, A, N\right) \\ &= D^{-1} c^{-r/2} (-\operatorname{sgn}(d)i)^{\nu} (dz - c)^k \sum_{\substack{An \equiv 0 \pmod{N} \\ n \in \mathbb{Z}'/N\mathbb{Z}'}} \Psi(n, h)\theta(z; n, A, N), \end{aligned}$$

where

$$\Psi(n, h) = \sum_{\substack{Al \equiv 0 \pmod{N} \\ l \in \mathbb{Z}'/N\mathbb{Z}'}} e(^t nAl/N^2)\Phi(h, l).$$

Here we understand $\operatorname{sgn}(d) = 1$ when $d = 0$. In addition, assume that $d \equiv 0 \pmod{2N}$. Then since

$$(4.9.12) \quad \Phi(h, l) = e(-b^l lAh/N^2)\Phi(h, 0),$$

we obtain

$$\begin{aligned} (4.9.13) \quad \Psi(n, h) &= \Phi(h, 0) \sum_{\substack{Al \equiv 0 \pmod{N} \\ l \in \mathbb{Z}'/N\mathbb{Z}'}} e(^t(n - bh)Al/N^2) \\ &= \begin{cases} \Phi(h, 0)D & \text{if } n \equiv bh \pmod{N}, \\ 0 & \text{otherwise.} \end{cases} \end{aligned}$$

Therefore we see

$$\begin{aligned} (4.9.14) \quad &\theta\left(\frac{bz - a}{dz - c}; h, A, N\right) \\ &= c^{-r/2} (-\operatorname{sgn}(d)i)^{\nu} (dz - c)^k \Phi(h, 0)\theta(z; bh, A, N). \end{aligned}$$

Rewriting (4.9.14), we obtain that

$$\begin{aligned} (4.9.15) \quad &\text{if } \gamma = \begin{bmatrix} a & b \\ c & d \end{bmatrix} (\in SL_2(\mathbb{Z})) \text{ is a matrix satisfying} \\ &b \equiv 0 \pmod{2}, \quad c \equiv 0 \pmod{2N}, \quad \text{and } d < 0, \end{aligned}$$

then

$$\theta(\gamma z; h, A, N) = M(\gamma)(cz + d)^k \theta(z; ah, A, N),$$

where

$$(4.9.16) \quad M(\gamma) = |d|^{-r/2} (-\operatorname{sgn}(c)i)^r \sum_{\substack{g \equiv h \pmod{N} \\ g \in \mathbb{Z}^r/dN\mathbb{Z}^r}} e(-bA[g]/2|d|N^2).$$

Lemma 4.9.2. *The notation being as above, we have*

$$M(\gamma) = e(abA[h]/2N^2) \left(\frac{D}{d}\right) \left(\frac{2c}{d}\right)^r \varepsilon_d^{-r},$$

where

$$\varepsilon_d = \begin{cases} 1 & \text{if } d \equiv 1 \pmod{4}, \\ i & \text{otherwise.} \end{cases}$$

Proof. Suppose $c = 0$. Then $a = d = -1$, so that the assertion is obvious. Next assume $c \neq 0$. We shall reduce the lemma to the case when $-d$ is a prime number. Assume that the assertion is true when $-d$ is a prime number. Take an integer n so that $p = -d - 2cn$ is a prime number, and put $\alpha(2n) = \begin{bmatrix} 1 & 2n \\ 0 & 1 \end{bmatrix}$. Since

$$\gamma\alpha(2n) = \begin{bmatrix} a & b + 2an \\ c & -p \end{bmatrix},$$

we see

$$M(\gamma\alpha(2n)) = M(\gamma)e(a^2nA[h]/N^2)$$

by (4.9.9) and (4.9.15). Since the assertion is true for $\gamma\alpha(2n)$ by assumption, we get

$$M(\gamma) = e(abA[h]/2N^2) \left(\frac{D}{-p}\right) \left(\frac{2c}{-p}\right)^r \varepsilon_{-p}^{-r}.$$

The character $\left(\frac{D}{-p}\right)$ is defined mod $4N$, since D is a divisor of N^r . Therefore we have

$$\left(\frac{2c}{-p}\right) = \left(\frac{2c}{d}\right), \quad \left(\frac{D}{-p}\right) = \left(\frac{D}{d}\right) \quad \text{and} \quad \varepsilon_{-p} = \varepsilon_d,$$

since $d \equiv -p \pmod{2c}$ and c is divisible by $2N$. Consequently the assertion is true for γ . Now we shall prove the assertion when $p = -d$ is a prime number. For $g \in \mathbb{Z}^r$ satisfying $g \equiv h \pmod{N}$, we take $u \in \mathbb{Z}^r$ so that $g = adh + Nu$. Note that $ad \equiv 1 \pmod{N}$. Then the set of the classes of $g \pmod{pN}$ corresponds to the set of the classes of $u \pmod{p}$, so that

$$(4.9.17) \quad M(\gamma) = (-\operatorname{sgn}(c)i)^r e(abA[h]/2N^2) p^{-r/2} \sum_{u \in \mathbb{Z}^r/p\mathbb{Z}^r} e(-bA[u]/2p).$$

Since $(p, 2D) = 1$, there exists an element $S \in M_r(\mathbb{Z})$ such that $(\det(S), p) = 1$ and $'SAS \bmod p$ is diagonal. Let t_1, \dots, t_r be the diagonal components of $'SAS$ and put $b' = -b/2$. Since it is easily verified by Lemma 3.1.1 that

$$\sum_{i=1}^p e(ai^2/p) = \left(\frac{a}{p}\right) W\left(\left(\frac{-}{p}\right)\right)$$

for a prime number p ($p \neq 2, (p, a) = 1$), it follows from Lemma 4.8.1(1) that

$$\begin{aligned} p^{-r/2} \sum_{u \in \mathbb{Z}^r/p\mathbb{Z}^r} e(b'A[u]/p) &= p^{-r/2} \prod_{i=1}^r \left(\sum_{j=1}^p e(b't_i j^2/p) \right) \\ &= \varepsilon_p^r \left(\frac{b'^r t_1 \dots t_r}{p} \right) \\ &= \varepsilon_p^r \left(\frac{b'^r D}{p} \right). \end{aligned}$$

Since $2b'c - ap = 1$, we have

$$\left(\frac{b'}{p}\right) = \left(\frac{2c}{p}\right) = \text{sgn}(c) \left(\frac{2c}{-p}\right).$$

By taking $\varepsilon_p \varepsilon_{-p} = i$ into account,

$$\begin{aligned} \varepsilon_p^r \left(\frac{b'^r D}{p}\right) &= (\text{sgn}(c)i)^r \varepsilon_{-p}^{-r} \left(\frac{2c}{-p}\right)^r \left(\frac{D}{-p}\right) \\ &= (\text{sgn}(c)i)^r \varepsilon_d^{-r} \left(\frac{2c}{d}\right)^r \left(\frac{D}{d}\right). \end{aligned}$$

This completes the proof. □

Theorem 4.9.3. Assume that A, h and N satisfy (4.9.1) and (4.9.2). Let $P(x)$ be a spherical function of degree ν with respect to A . Then for an element $\gamma = \begin{bmatrix} a & b \\ c & d \end{bmatrix}$ of $SL_2(\mathbb{Z})$ satisfying

$$b \equiv 0 \pmod{2}, \quad c \equiv 0 \pmod{2N},$$

we have

$$\begin{aligned} &\theta(\gamma z; h, A, N, P) \\ &= e(abA[h]/2N^2) \left(\frac{\det(A)}{d}\right) \left(\frac{2c}{d}\right)^r \varepsilon_d^{-r} (cz + d)^k \theta(z; ah, A, N, P), \end{aligned}$$

where $k = r/2 + \nu$, and

$$\varepsilon_d = \begin{cases} 1 & \text{if } d \equiv 1 \pmod{4}, \\ i & \text{if } d \equiv 3 \pmod{4}. \end{cases}$$

Proof. If $d < 0$, then the assertion follows from (4.9.15) and Lemma 4.9.2. If $d > 0$, then we may consider $-\gamma$ in place of γ . □

If we impose some additional conditions on A , Theorem 4.9.3 can be refined as follows:

1° Assume that all the diagonal components of A are even, then

$$\theta(z + 1; h, A, N) = e(A[h]/2N^2)\theta(z; h, A, N).$$

Note that $A[m]$ is even for any $m \in \mathbb{Z}'$. Therefore by using this equality in place of (4.9.10),

the transformation formula of Theorem 4.9.3 holds for any element γ of $\Gamma_0(2N)$.

2° Suppose that all the diagonal components of A and NA^{-1} are even. Then (4.9.12) holds for any d such that $d \equiv 0 \pmod N$, so that

the transformation formula of Theorem 4.9.3 holds for any element γ of $\Gamma_0(N)$.

We consider the special cases when r is even or $r = 1$.

Corollary 4.9.4. *The notation being as in Theorem 4.9.3, if r is even, then*

$$\theta(2z; h, A, N, P) \in \mathcal{G}_k(\Gamma_1(4N))$$

with $k = r/2 + v$. Furthermore, if $v \geq 1$, then $\theta(2z; h, A, N, P)$ is a cusp form.

Proof. The automorphy is straightforward from Theorem 4.9.3. Therefore we have only to verify the conditions at cusps. First consider the case when all the diagonal components of A are even. Let R be the space generated by

$$\{\theta(z; h, A, N, P) \mid h \in \mathbb{Z}'/N\mathbb{Z}'\}.$$

Lemma 4.9.1 and the above remark 1° imply that R is stable under $\begin{bmatrix} 1 & 1 \\ 0 & 1 \end{bmatrix}$ and

$\begin{bmatrix} 0 & -1 \\ 1 & 0 \end{bmatrix}$, and therefore, under $SL_2(\mathbb{Z})$. Since any element of R is holomorphic (resp. has a zero if $v \geq 1$) at ∞ , and all cusps of $\Gamma(N)$ are $SL_2(\mathbb{Z})$ -equivalent to ∞ , any element of R is holomorphic (resp. has zeros if $v \geq 1$) at all cusps. The general case is reduced to the above case by (4.9.9) with $c = 2$. □

Corollary 4.9.5. *The notation being as in Corollary 4.9.4, let*

$$\chi = \left(\frac{(-1)^{r/2} \det(A)}{2} \right),$$

and put

$$\theta(z; A, P) = \sum_{m \in \mathbb{Z}'} P(m) e\left(\frac{A[m]}{2} z\right).$$

Then

(1) $\theta(2z; A, P) \in \mathcal{G}_k(4N, \chi)$;

(2) If all the diagonal components of A are even, then $\theta(z; A, P) \in \mathcal{G}_k(2N, \chi)$;

(3) If all the diagonal components of A and NA^{-1} are even, then $\theta(z; A, P) \in \mathcal{G}_k(N, \chi)$ and

$$(\sqrt{N}z)^{-k} \theta(-1/Nz; A, P) = \frac{\sqrt{N}^k}{\sqrt{D}} i^{r/2} (-1)^k \theta(z; A^*, P^*),$$

where

$$A^* = NA^{-1}, \quad P^*(x) = P(A^{-1}x).$$

If $v \geq 1$, then $\theta(z; A, P)$ is a cusp form.

Proof. All the assertions follow from Theorem 4.9.3, the remarks mentioned after that, and Corollary 4.9.4 by taking $h = 0$, except for the transformation formula in (3) which is obvious from (4.9.8). \square

As an application of theta functions to quadratic forms, we state the following

Corollary 4.9.6. *Assume that r is even. Then there exists a positive definite symmetric matrix A in $M_r(\mathbb{Z})$ satisfying the following conditions if and only if $r \equiv 0 \pmod 8$.*

(i) $\det(A) = 1$;

(ii) all the diagonal components of A and A^{-1} are even.

Proof. We use the same notation as in Corollary 4.9.5. First let us prove the only-if part. For $P(x) = 1$, we put

$$\theta(z; A) = \theta(z; A, P)$$

and

$$\theta(z; A^{-1}) = \theta(z; A^{-1}, P).$$

Since

$$\theta(z; A) = \theta(z; A^{-1}),$$

and $\theta(z; A) \in \mathcal{G}_k(\Gamma(1))$ by Corollary 4.9.5(3), we get

$$z^{-k}\theta(-1/z; A) = \theta(z; A),$$

so that comparing this with the transformation formula in Corollary 4.9.5(3), we obtain $r^{1/2} = 1$, namely, $r \equiv 0 \pmod 8$. Conversely, if $r = 8$, then

$$A = \begin{bmatrix} 2 & 1 & & & & & & & \\ & 1 & 2 & 1 & & & & & 0 \\ & & 1 & 4 & 3 & & & & \\ & & & 3 & 4 & 5 & & & \\ & & & & 5 & 20 & 3 & & \\ & & & & & 3 & 12 & 1 & \\ & & & & & & & 1 & 4 & 1 \\ 0 & & & & & & & & & 1 & 2 \end{bmatrix} \quad (\in M_8(\mathbb{Z}))$$

satisfies (i) and (ii) (Minkowski). Therefore $r \equiv 0 \pmod 8$ is the sufficient condition. \square

If r is odd, then theta functions are not modular forms in the usual sense. We here state the explicit transformation formula only for the case when $r = 1$.

Corollary 4.9.7. *Let ψ be a primitive Dirichlet character of conductor N , and $\nu = 0$, or 1 such that $\psi(-1) = (-1)^\nu$. Put*

$$\theta_\psi(z) = \sum_{m=-\infty}^{\infty} \psi(m)m^\nu e^{2\pi im^2 z},$$

and

$$J(\gamma, z) = \left(\frac{c}{d}\right) \varepsilon_d^{-1} (cz + d)^{1/2}$$

for $\gamma = \begin{bmatrix} a & b \\ c & d \end{bmatrix} \in \Gamma_0(4)$. Then

$$(1) \quad \theta_\psi(\gamma z) = \psi(d) \left(\frac{-1}{d}\right)^\nu J(\gamma, z)^{2\nu+1} \theta_\psi(z)$$

for any $\gamma = \begin{bmatrix} a & b \\ c & d \end{bmatrix} \in \Gamma_0(4N^2)$;

$$(2) \quad (2Nz/i)^{-\nu-1/2} \theta_\psi(-1/4N^2 z) = (-i)^\nu N^{-1/2} W(\psi) \theta_{\bar{\psi}}(z).$$

Proof. We get

$$\theta_\psi(z) = \sum_{h \in \mathbb{Z}/N\mathbb{Z}} \psi(h) \theta(2Nz; h, N, N, P)$$

with $P(x) = x^\nu$ by taking $r = 1$, $A = N$, so that the first assertion follows from Theorem 4.9.3. The second one is easily verified by (4.9.7). \square

Taking the principal character as ψ in Corollary 4.9.7, and writing

$$\theta(z) = \theta_\psi(z),$$

we have

$$\theta(\gamma z) = J(\gamma, z) \theta(z) \quad (\gamma \in \Gamma_0(4)).$$

In particular,

$$(4.9.18) \quad J(\gamma\delta, z) = J(\gamma, \delta z) J(\delta, z) \quad (\gamma, \delta \in \Gamma_0(4)).$$

Let Γ be a Fuchsian group of the first kind, and $J(\gamma, z)$ a holomorphic function on \mathbf{H} without zeros for $\gamma \in \Gamma$. If $J(\gamma, z)$ satisfies (4.9.18), then we call $J(\gamma, z)$ an *automorphic factor of Γ* . For an automorphic factor of Γ , we can define similarly automorphic forms as in the case $j(\gamma, z)$. Corollary 4.9.7 shows that $\theta_\psi(z)$ is an automorphic form with respect to the automorphic factor $\psi(d) \left(\frac{-1}{d}\right)^\nu J(\gamma, z)^{2\nu+1}$.

Such automorphic forms are called *modular forms of half-integral weight*, and are as important as modular forms of integral weight. They are closely connected with modular forms of integral weight. See [Shimura 7], [Shintani] and [Waldspurger]. Furthermore we can obtain again the functional equations of Dirichlet L -functions mentioned in §3.3 from Corollary 4.9.7 and Theorem 4.3.5. Theorem 4.8.2 can be also proved from Theorem 4.9.3.

Chapter 5. Unit Groups of Quaternion Algebras

In the previous chapter, we studied modular groups and modular forms. The unit groups Γ of orders of indefinite quaternion algebras defined over \mathbb{Q} are also Fuchsian groups and they are generalizations of modular groups. Automorphic forms for such groups Γ also play important roles in the algebraic geometrical theory of numbers. In this chapter, we recall fundamental properties of quaternion algebras, and study the structure of Hecke algebras of Γ . We quote some basic results on algebras and number theory from [Weil]. We follow [Eichler], [Shimizu 4] in §5.2, and [Shimura 3], [Shimizu 3] in §5.3, respectively. For a general reference, we mention also [Vignéras].

§ 5.1. Algebras over \mathbb{Q} and Adelization

We call a ring B with unity an *algebra of dimension n over a field F* , if the following three conditions are satisfied:

- 1° $F \subset B$, and the unity of F coincides with the unity of B ;
- 2° any element of F commutes all elements of B ;
- 3° B is a vector space over F of dimension n .

Let B be an algebra over F . We denote by $\dim_F B$ the dimension of B over F . We put

$$Z(B) = \{ \beta \in B \mid \alpha\beta = \beta\alpha \text{ for any } \alpha \in B \},$$

and call it the *center* of B . When $F = Z(B)$, we call B a *central algebra over F* . For two algebras A, B over F , a ring homomorphism $f: A \rightarrow B$ is called an *F -homomorphism* (resp. *F -isomorphism*), if f is also a homomorphism (resp. isomorphism) as vector spaces over F . We denote by $E(B)$ the set of all endomorphisms of B as a vector space over F . It is also an algebra over F . For an element α of B , we denote by $\rho(\alpha)$ the homomorphism " $B \ni \beta \mapsto \alpha\beta \in B$ ". The mapping ρ of B into $E(B)$ is an injective F -homomorphism. We call ρ the *left regular representation* of B . If $\rho(\alpha)$ is an automorphism of B , then there exists an element $\beta \in B$ such that $\rho(\alpha)(\beta) = \alpha\beta = 1$. Then $\rho(\beta) = \rho(\alpha)^{-1}$, and therefore, $\rho(\alpha)\rho(\beta) = \rho(\beta)\rho(\alpha) = 1$. Since ρ is injective, we see that $\alpha\beta = \beta\alpha = 1$, or α is invertible. Conversely, if $\alpha \in B^\times$, then $\rho(\alpha)$ is obviously an automorphism of B . Therefore, for an element α of B ,

(5.1.1) α belongs to B^\times if and only if $\rho(\alpha)$ is an automorphism of B as a vector space.

For each prime number p , we denote by \mathbb{Q}_p and \mathbb{Z}_p the field of p -adic numbers and the ring of p -adic integers, respectively. For a non-zero element a of \mathbb{Q}_p , we put

$$\text{ord}_p(a) = \max\{m \in \mathbb{Z} \mid a \in p^m \mathbb{Z}_p\},$$

and

$$|a|_p = p^{-e} \quad (e = \text{ord}_p(a)).$$

We also put $|0|_p = 0$. Moreover we put

$$\mathbb{Q}_\infty = \mathbb{R},$$

and for any element a_∞ of \mathbb{Q}_∞ , we denote by $|a_\infty|_\infty$ the absolute value of a_∞ in the usual sense. Hereafter we call \mathbb{Q}_p and \mathbb{Q}_∞ *local fields*, and denote by v a prime number p or ∞ . We shall study algebras over local fields \mathbb{Q}_v . Let B be an n -dimensional algebra over \mathbb{Q}_v . Since B is isomorphic to the product \mathbb{Q}_v^n of \mathbb{Q}_v as vector spaces over \mathbb{Q}_v , we can induce a topology on B under which B is homeomorphic to \mathbb{Q}_v^n . This topology is independent of the isomorphism. Since \mathbb{Q}_v is locally compact, so is B . Furthermore, since all the coordinates of the sum, the subtraction and the product of two elements α, β are polynomial functions of coordinates of α and β , they are continuous with respect to the topology of B , and B is a topological ring. Since

$$B^\times = \{\alpha \in B \mid \det(\rho(\alpha)) \neq 0\}$$

by (5.1.1), B^\times is open in B , and therefore, it is a locally compact topological group with respect to the topology induced from B .

Let $F = \mathbb{Q}$ (resp. \mathbb{Q}_p), $\mathfrak{r} = \mathbb{Z}$ (resp. \mathbb{Z}_p), and B an algebra over F . A subset R of B is called an *order* of B , if the following two conditions are satisfied:

- (i) R is a subring containing the unity of B ;
- (ii) R is finitely generated over \mathfrak{r} , and contains a basis of B over F .

By definition, orders of B are commensurable as submodules of B . An order of B is called *maximal* if it is maximal with respect to inclusion.

Lemma 5.1.1. (1) *Let B be an algebra over \mathbb{Q}_p , and R an order of B . Then R is compact and R^\times is a compact subgroup of B^\times .*

(2) *Let B be an algebra over \mathbb{Q} , and R an order of B . We put*

$$B_p = B \otimes_{\mathbb{Q}} \mathbb{Q}_p,$$

and let R_p the closure of R in B_p for each prime number p . Then R_p is an order of B_p .

Proof. (1): Since R is finitely generated over \mathbb{Z}_p and is a submodule of the vector space B , there exist $\alpha_1, \dots, \alpha_n \in R$ such that

$$R = \mathbb{Z}_p \alpha_1 \oplus \cdots \oplus \mathbb{Z}_p \alpha_n$$

by the elementary divisor theory, where $n = \dim_{\mathbb{Q}_p} B$. Therefore R is homeomorphic to \mathbb{Z}_p^n and is compact. By a similar argument as in (5.1.1) we obtain

$$R^\times = \{\alpha \in R \mid \det(\rho(\alpha)) \in \mathbb{Z}_p^\times\},$$

where ρ is the left regular representation of B , so that R^\times is open and closed in R . Therefore R^\times is compact. (2): A similar argument as above implies that there exists a basis of B such that

$$R = \mathbb{Z}\alpha_1 \oplus \cdots \oplus \mathbb{Z}\alpha_n,$$

so that

$$R_p = \mathbb{Z}_p\alpha_1 \oplus \cdots \oplus \mathbb{Z}_p\alpha_n.$$

Therefore R_p is finitely generated over \mathbb{Z}_p . It is obvious that R_p contains the unity of B_p and a basis of B_p . □

We denote by \mathbb{Q}_A the *adele ring of \mathbb{Q}* . In other words, it is a locally compact topological ring defined by the following conditions:

(i) as a set,

$$\mathbb{Q}_A = \{(a_v) \in \prod_v \mathbb{Q}_v \mid a_p \in \mathbb{Z}_p \text{ for almost all prime numbers } p\};$$

(ii) the topology is defined by considering the subset $\mathbb{R} \times \prod_p \mathbb{Z}_p$ of \mathbb{Q}_A open in \mathbb{Q}_A , and the induced topology on $\mathbb{R} \times \prod_p \mathbb{Z}_p$ coincides with the product topology. Let \mathbb{Q}_A^\times be the set of all invertible elements of \mathbb{Q}_A . For $a = (a_v) \in \mathbb{Q}_A^\times$, we put

$$|a|_A = \prod_v |a_v|_v.$$

This is meaningful since $|a_p|_p = 1$ for almost all prime numbers p by (i). We consider \mathbb{Q} as a subset of \mathbb{Q}_A through the correspondence “ $\mathbb{Q} \ni x \mapsto (x_v) \in \mathbb{Q}_A$ ” with $x_v = x$ for all v . Then

$$\mathbb{Q}^\times \subset \mathbb{Q}_A^\times,$$

and

$$|x|_A = 1 \quad (x \in \mathbb{Q}^\times).$$

Let $a = (a_v) \in \mathbb{Q}_A^\times$. For each prime number p , put $e_p = \text{ord}_p(a_p)$. Then

$$a_p \mathbb{Z}_p = p^{e_p} \mathbb{Z}_p.$$

Since $e_p = 0$ for almost all p , $m = \prod_p p^{e_p}$ is meaningful and is a rational number. We define the fractional ideal of \mathbb{Q} by

$$\text{id}(a) = m\mathbb{Z},$$

and call it the *ideal associated with a* .

For an algebra B over \mathbb{Q} of dimension n , we put

$$(5.1.2) \quad B_A = B \otimes_{\mathbb{Q}} \mathbb{Q}_A.$$

Since B_A is isomorphic to the product \mathbb{Q}_A^n as a \mathbb{Q}_A -module through the coordinates with respect to a basis of B , we can induce the topology on B_A under which B_A is homeomorphic to the product space \mathbb{Q}_A^n . This topology is uniquely determined and B_A is a topological ring. Since \mathbb{Q}_A is locally compact, so is B_A . Since \mathbb{Q}_A is a subset of the product $\prod_v \mathbb{Q}_v$, we can consider B_A as a subset of the product $\prod_v B_v$ through the natural embedding, where $B_v = B \otimes_{\mathbb{Q}} \mathbb{Q}_v$. Let R be an order of B , and R_p

the closure of R in B_p for each prime number p . Then we have

$$(5.1.3) \quad B_A = \{(\alpha_v) \in \prod_v B_v \mid \alpha_p \in R_p \text{ for almost all prime numbers } p\},$$

and the induced topology of B_A on the subset $B_\infty \times \prod_p R_p$ coincides with the product topology. We call B_A the *adelization* of B . Next let B_A^\times be the set of all invertible elements of B_A , and induce on B_A^\times the weakest topology under which the natural injection: $B_A^\times \rightarrow B_A$ is continuous. Then B_A^\times is a topological group. We call B_A^\times the *adelization* of B^\times . As a set,

$$(5.1.4) \quad B_A^\times = \{(\alpha_v) \in \prod_v B_v^\times \mid \alpha_p \in R_p^\times \text{ for almost all prime numbers } p\},$$

and the induced topology on the open subgroup $B_\infty^\times \times \prod_p R_p^\times$ of B_A^\times coincides with the product topology. When $B = \mathbb{Q}$, B_A^\times is nothing but \mathbb{Q}_A^\times , which is called the *idele group* of \mathbb{Q} .

§5.2. Quaternion Algebras

Let B be an algebra over a field F . We call B *simple* if B is simple as a ring, namely, if B has no two-sided ideals except for $\{0\}$ and B itself. We call B a *division algebra* if any nonzero element of B is invertible. For an invertible element β of B , the correspondence:

$$B \ni \alpha \mapsto \beta \alpha \beta^{-1} \in B$$

is an automorphism of B . Such an automorphism is called an *inner automorphism* of B .

Theorem 5.2.1. *Let B be a central simple algebra over a field F , and C_1, C_2 two simple subalgebras of B over F . Then any F -isomorphism of C_1 onto C_2 can be extended to an inner automorphism of B . In particular, any automorphism of B is derived from an inner automorphism of B .*

Proof. Since left ideals of B are vector spaces over F , the descending chain condition holds on left ideals. Let M be a minimal left ideal of B . Then M is a simple B -module. Since B is simple, the action of B on M is faithful. Put

$$D = \text{End}_B(M),$$

the ring of all endomorphisms of M as a B -module. Then D is a central simple algebra over F , and

$$\text{End}_D(M) = B$$

([Weil, IX, Prop. 2]). Now let f be an F -isomorphism of C_1 onto C_2 . Since the actions of C_1 and D on M are mutually commutative, M can be considered as a left $C_1 \otimes_F D$ -module. We denote by M_1 the $C_1 \otimes_F D$ -module M . Similarly, M can also be considered as a left $C_2 \otimes_F D$ -module, so that we can consider M as a left

$C_1 \otimes_F D$ -module through the isomorphism f of C_1 onto C_2 . We denote this $C_1 \otimes_F D$ -module M by M_2 . Let K be the center of C_1 . Then K is a field, and

$$C_1 \otimes_F D = C_1 \otimes_K (K \otimes_F D),$$

so that $C_1 \otimes_F D$ is simple ([Weil, IX, Prop. 3–Cor. 1, Cor. 4]). Therefore both M_1 and M_2 are isomorphic to direct sums of copies of a unique simple $C_1 \otimes_F D$ -module ([Weil, IX, Prop. 1]). By comparing the dimensions of M_1 and M_2 over F , we see that M_1 is isomorphic to M_2 as $C_1 \otimes_F D$ -modules. We denote by ϕ this isomorphism. Then, first ϕ is an F -automorphism of M and is compatible with the action of D , so that ϕ is an element of $\text{End}_D(M)$. Since $\text{End}_D(M) = B$, there exists an element β of B^\times such that

$$\phi(m) = \beta m \quad (m \in M).$$

Next for any $\gamma \in C_1$ and any $\psi \in D$, we see

$$\phi((\gamma \otimes \psi)m) = (\gamma \otimes \psi)\phi(m) \quad (m \in M),$$

namely,

$$\beta\gamma\psi(m) = \gamma\psi(\beta m) = f(\gamma)\psi(\beta m) = f(\gamma)\beta\psi(m).$$

Taking the identity mapping as ψ , we have $\beta\gamma m = f(\gamma)\beta m$ for any $m \in M$. Since the action of B on M is faithful, we get $\beta\gamma = f(\gamma)\beta$, namely,

$$f(\gamma) = \beta\gamma\beta^{-1}$$

for any $\gamma \in C_1$. Therefore the inner automorphism g of B defined by $g(\alpha) = \beta\alpha\beta^{-1}$ is an extension of f over B . This proves the first half of the assertion; the latter half is obvious. □

A central simple algebra B of dimension 4 over a field F is called a *quaternion algebra* over F . Furthermore, if B is a division algebra, we call B a *division quaternion algebra*.

Let B be a quaternion algebra over a field F . By Wedderburn’s theorem ([Weil, IX, Th. 1 and Prop. 3–Cor. 1]), we see

(5.2.1) B is not a division quaternion algebra if and only if B is isomorphic to $M_2(F)$.

If F is algebraically closed, then $M_2(F)$ is a unique quaternion algebra over F up to isomorphisms ([Weil, IX, Prop. 3–Cor. 2]).

Let K be any extension over F . Then $B \otimes_F K$ is a quaternion algebra over K ([Weil, IX, Prop. 3–Cor. 1]). We say that B is *ramified* or *splits* over K if $B \otimes_F K$ is a division quaternion algebra or is isomorphic to $M_2(K)$, respectively. When B splits over K , we call K a *splitting field* of B . The first assertion of the following lemma can be seen in [Weil, IX, Th. 3–Cor. 3].

Lemma 5.2.2. *Let B be a quaternion algebra over a field F .*

(1) *A separable extension K of degree 2 over F is a splitting field of B if and only if B contains a subfield isomorphic to K .*

(2) If two elements α, β of B^\times have the same minimal polynomials, then α and β are B^\times -conjugate.

(3) If an element α of B is not contained in F , then the set of the elements of B commutative with α coincides with $F[\alpha]$.

Proof. (2): Let $f(X) \in F[X]$ be the minimal polynomial of both α and β . Then

$$F[\alpha] \simeq F[X]/(f(X)) \simeq F[\beta].$$

First suppose $f(X)$ is irreducible. Then both $F[\alpha]$ and $F[\beta]$ are fields, so that the above isomorphism can be extended to an inner automorphism of B by Theorem 5.2.1. Therefore α and β are B^\times -conjugate. Next assume that $f(X)$ is reducible. Then $F[\alpha] \simeq F[X]/(f(X))$, and it is not a field, so that $B \simeq M_2(F)$ by (5.2.1). We may assume $B = M_2(F)$. Since α and β have the same minimal polynomials, their Jordan's normal forms are the same, say γ . Since eigenvalues of α and β belong to F , α and β are conjugate to γ by elements of $GL_2(F)$. Since $B^\times = GL_2(F)$, α and β are B^\times -conjugate. (3): If $F[\alpha]$ is not a field, then $B \simeq M_2(F)$. Therefore by (2) we may assume that α is a Jordan's normal form. By a direct calculation, we obtain the result. Assume that $F[\alpha]$ is a field, and let β be an element of B commutative with α . Since $F[\alpha, \beta]$ is an algebra over $F[\alpha]$, we see $\dim_F F[\alpha, \beta] = 2$ or 4 . Since B is not commutative, $F[\alpha, \beta] = F[\alpha]$. \square

Let B be a quaternion algebra over a field F , and \bar{F} the algebraic closure of F . Since $B \otimes_F \bar{F}$ is a quaternion algebra over the algebraically closed field \bar{F} , $B \otimes_F \bar{F}$ is isomorphic to $M_2(\bar{F})$. For an element β of B , we put

$$N_B(\beta) = \det(\beta), \quad \text{tr}_B(\beta) = \text{tr}(\beta),$$

where $\det(\beta)$ and $\text{tr}(\beta)$ are the determinant and the trace of β as an element of $B \otimes_F \bar{F} \simeq M_2(\bar{F})$, respectively. When $B = M_2(F)$, $N_B(\beta)$ and $\text{tr}_B(\beta)$ are nothing but the determinant and the trace of β as a matrix. We can prove that both $N_B(\beta)$ and $\text{tr}_B(\beta)$ belong to F ([Weil, IX, Prop. 6]). We call $N_B(\beta)$ and $\text{tr}_B(\beta)$ the (*reduced*) norm and the (*reduced*) trace of β , respectively. If F is an infinite field, then $N_B(\beta)$ is a polynomial function of the coordinates of β with respect to a fixed basis of B over F .

When $F = \mathbb{Q}$, N_B and tr_B induce mappings from $B_v = B \otimes_{\mathbb{Q}} \mathbb{Q}_v$ into \mathbb{Q}_v for any v ($= p$ or ∞), which are nothing but N_{B_v} and tr_{B_v} , respectively. We denote N_{B_v} and tr_{B_v} simply by N_B and tr_B , respectively, for simplicity. Moreover N_B and tr_B induce the continuous mappings of B_A into \mathbb{Q}_A , which we also denote by N_B and tr_B , respectively.

For an element β of B , we put

$$f(X; \beta) = X^2 - \text{tr}_B(\beta)X + N_B(\beta) \quad (\in F[X]),$$

and call it the *principal polynomial* of β . By definition,

$$f(\beta; \beta) = 0,$$

and if $\beta \notin F$, then $f(X; \beta)$ is the minimal polynomial of β over F . If $f(X; \beta)$ is

irreducible, then $F[\beta]$ is a quadratic extension over F , and the restrictions of tr_B and N_B on $F[\beta]$ coincide with the trace and the norm of the field $F[\beta]$ over F .

The proof of the following lemma on quaternion algebras over \mathbb{Q}_p can be seen in [Weil, XI, Th. 6, Prop. 5 and X, Th. 1, Prop. 6].

Lemma 5.2.3. (1) *Let B be a division quaternion algebra over \mathbb{Q}_p . Put*

$$R = \{ \beta \in B \mid N_B(\beta) \in \mathbb{Z}_p, \text{tr}_B(\beta) \in \mathbb{Z}_p \}.$$

Then R is a unique maximal order of B . Any left or right ideal of R is always a two-sided ideal. R has a unique maximal ideal $\mathfrak{m} = R\pi = \pi R$ ($\pi \in R$). Moreover $\pi^2 R = pR$. (We call π a prime element of B .)

(2) *The ring $M_2(\mathbb{Z}_p)$ is a maximal order of $M_2(\mathbb{Q}_p)$, and any maximal order of $M_2(\mathbb{Q}_p)$ is conjugate to $M_2(\mathbb{Z}_p)$.*

(3) *Let B be a quaternion algebra over \mathbb{Q}_p , and R a maximal order of B . Then any left or right ideal of R is principal. Moreover,*

$$N_B(B) = \mathbb{Q}_p,$$

$$N_B(R) = \mathbb{Z}_p,$$

and

$$N_B(R^\times) = \mathbb{Z}_p^\times.$$

The following lemma is based on [Weil, XI, Prop. 4, Th. 1 and IV, Th. 4].

Lemma 5.2.4. *Let B be a quaternion algebra over \mathbb{Q} .*

(1) *Let R be an order of B . Then there exists a maximal order of B containing R , and R is maximal if and only if R_p is maximal in B_p for all prime numbers p , where R_p is the closure of R in $B_p = B \otimes_{\mathbb{Q}} \mathbb{Q}_p$.*

(2) *For almost all prime numbers p , B_p is isomorphic to $M_2(\mathbb{Q}_p)$, and R_p is maximal.*

(3) *Suppose that for each prime number p , an order R'_p of B_p is given. If $R'_p = R_p$ for almost all prime numbers p with some order R of B , then there exists an order S of B such that $R'_p = S_p$ for all prime numbers p .*

(4) *If R is an order of B , then $R = (B_\infty \times \prod_p R_p) \cap B$.*

(5) *Put*

$$B_A^{(1)} = \{ \beta \in B_A^\times \mid |N_B(\beta)|_A = 1 \},$$

If B is a division quaternion algebra, then $B^\times \setminus B_A^{(1)}$ is compact.

Let B be a quaternion algebra over \mathbb{Q} . We call B *indefinite* or *definite* according as $B \otimes_{\mathbb{Q}} \mathbb{R}$ is isomorphic to $M_2(\mathbb{R})$ or is a division quaternion algebra. We are going to prove the approximation theorem. We begin with some lemmas.

Lemma 5.2.5. *Let B be a quaternion algebra over \mathbb{Q} . Assume that a quadratic polynomial*

$$f(X) = X^2 + aX + b \in \mathbb{Q}[X]$$

has no multiple roots. Then the following four statements are equivalent:

- (1) $f(X)$ is the principal polynomial of some element of B ;
- (2) B splits over the splitting field of $f(X)$ over \mathbb{Q} ;
- (3) B_v splits over the splitting field of $f(X)$ over \mathbb{Q}_v for all v ;
- (4) $f(X)$ is the principal polynomial of some element of B_v for all v .

Proof. (1) \Rightarrow (2): Let $f(X) = f(X; \beta)$ for some $\beta \in B$. First suppose $f(X)$ is irreducible over \mathbb{Q} . Then $\mathbb{Q}[\beta]$ is a quadratic extension of \mathbb{Q} included in B , so that B splits over $\mathbb{Q}[\beta]$ by Lemma 5.2.2(1). Next assume that $f(X)$ is reducible over \mathbb{Q} . Since $f(X)$ is a principal polynomial, we see $B \simeq M_2(\mathbb{Q})$ from the proof of Lemma 5.2.2. This proves (2). (2) \Rightarrow (1): This is easily verified by Lemma 5.2.2(1). (2) \Leftrightarrow (3): This is nothing but the Hasse principle ([Weil, XI, Th. 2]). (3) \Leftrightarrow (4): This can be similarly proved as (1) \Leftrightarrow (2). □

Lemma 5.2.6. *Let B be a quaternion algebra over \mathbb{Q}_p , R a maximal order of B , and h a positive integer. If $b \in \mathbb{Z}_p$ satisfies $b \equiv 1 \pmod{p^h \mathbb{Z}_p}$, then there exists an element β of R satisfying the following three conditions:*

- (i) $N_B(\beta) = b$;
- (ii) $\beta \equiv 1 \pmod{p^h R}$;
- (iii) $f(X; \beta)$ is irreducible over \mathbb{Q}_p .

Proof. Any quadratic extension K of \mathbb{Q}_p is a splitting field of B by [Weil], XII, Th. 2–Cor. 2, so that we may assume that K is included in B . Take an unramified quadratic extension as K , and let \mathfrak{r} be the maximal order of K . If R' is a maximal order of B including \mathfrak{r} , then R' is conjugate to R , so that we may assume $\mathfrak{r} \subset R$. If an element β of B does not belong to \mathbb{Q}_p , then its minimal polynomial coincides with its principal polynomial, so that we have only to prove the existence of an element in $\mathfrak{r} - \mathbb{Z}$ satisfying (i) and (ii). We simply denote by N the Norm mapping N_{K/\mathbb{Q}_p} . By induction we construct a sequence $\{\alpha_n\}_{n=1}^\infty$ of elements of \mathfrak{r} satisfying

$$(1) \alpha_1 = 1, (2) \alpha_n \equiv \alpha_{n-1} \pmod{p^{h(n-1)}\mathfrak{r}}, (3) N(\alpha_n) \equiv b \pmod{p^{hn}\mathbb{Z}_p}.$$

Assuming we have constructed $\{\alpha_1, \dots, \alpha_n\}$, we shall show the existence of α_{n+1} . Since K is unramified over \mathbb{Q}_p , we have

$$\text{tr}_{K/\mathbb{Q}_p}(\mathfrak{r}) = \mathbb{Z}_p,$$

so that there exists an element γ of \mathfrak{r} satisfying

$$\text{tr}_{K/\mathbb{Q}_p}(\gamma) = 1.$$

Put

$$\alpha_{n+1} = \alpha_n(1 + c\gamma) \quad (c = (b - N(\alpha_n))/N(\alpha_n)).$$

Since $\alpha_n \in \mathfrak{r}^\times$ by (1) and (2), we see

$$c \equiv 0 \pmod{p^{hn}\mathbb{Z}_p}.$$

Then

$$\alpha_{n+1} \equiv \alpha_n \pmod{p^{hn}\mathfrak{r}},$$

and

$$\begin{aligned} N(\alpha_{n+1}) &= N(\alpha_n)N(1+c\gamma) \\ &\equiv N(\alpha_n)(1+c) \\ &\equiv b \pmod{p^{h(n+1)}\mathbb{Z}_p}. \end{aligned}$$

Therefore α_{n+1} is a desired one. Since $\{\alpha_n\}$ is a Cauchy sequence by (2), it is convergent. So put

$$\alpha = \lim_{n \rightarrow \infty} \alpha_n.$$

Then α satisfies (i) and (ii). If $\alpha \notin \mathbb{Z}_p$, then $\beta = \alpha$ is what we want. Assume $\alpha \in \mathbb{Z}_p$. Let $\{\omega_1, \omega_2\}$ be a basis of r over \mathbb{Z}_p , and σ the generator of $\text{Gal}(K/\mathbb{Q}_p)$. Put

$$\psi = 1 + p^h(n_1\omega_1 + n_2\omega_2) \quad (n_1, n_2 \in \mathbb{Z}_p).$$

If we can take n_1 and n_2 so that

$$\psi^\sigma / \psi \notin \mathbb{Z}_p,$$

then $\beta = \alpha(\psi^\sigma / \psi)$ is what we seek. Since $N(\psi^\sigma / \psi) = 1$, $\psi^\sigma / \psi \in \mathbb{Z}_p$ if and only if $\psi^\sigma / \psi = \pm 1$. Since $\{\omega_1, \omega_2\}$ is a basis of K over \mathbb{Q}_p , we can find n_1 and n_2 so that

$$\psi^\sigma \neq \pm \psi.$$

This completes the proof. □

An element β of a quaternion algebra B over a field F is called *regular* if $f(X; \beta)$ has no multiple roots.

Lemma 5.2.7. *Let B be a quaternion algebra over \mathbb{Q}_p , R an order of B , and h a positive integer. For an element β of B satisfying $N_B(\beta) = 1$, there exists a regular element α of B such that*

$$(i) \ N_B(\alpha) = 1, \quad (ii) \ \alpha \equiv \beta \pmod{p^h R}.$$

Proof. If β is regular, then the assertion is trivial. Assume β is not regular. First suppose $B = M_2(\mathbb{Q}_p)$. Then there exists an element γ of B^\times such that

$$\gamma\beta\gamma^{-1} = \pm \begin{bmatrix} 1 & b \\ 0 & 1 \end{bmatrix}, \quad b \in \mathbb{Q}_p.$$

Taking a positive integer l so that

$$p^l \gamma^{-1} M_2(\mathbb{Z}_p) \gamma \subset p^h R,$$

we put

$$\alpha = \pm \gamma^{-1} \begin{bmatrix} 1-p^l & b \\ 0 & (1-p^l)^{-1} \end{bmatrix} \gamma.$$

Then α satisfies (i) and (ii). Next assume that B is a division quaternion algebra. Then $\beta = \pm 1$, so that the assertion follows from Lemma 5.2.6. □

Now let B be a quaternion algebra over \mathbb{Q} . We denote by \mathbb{Q}^2 the product of two copies of \mathbb{Q} . For an element β of B , we put

$$(5.2.2) \quad \phi(\beta) = (\text{tr}_B(\beta), N_B(\beta)) \in \mathbb{Q}^2.$$

The mapping ϕ induces continuous mappings of B_v into \mathbb{Q}_v^2 , and also of B_A into \mathbb{Q}_A^2 , which are denoted by the same symbol ϕ , for simplicity.

Lemma 5.2.8. *Let β be a regular element of B_p . Then we have:*

- (1) any element sufficiently close to β is also regular;
- (2) ϕ is an open mapping on a neighborhood of β . Namely, if V is an open neighborhood of β , then $\phi(V)$ contains an open neighborhood of $\phi(\beta)$.

Proof. (1): For an element $(a, b) \in \mathbb{Q}_p^2$, we put

$$g(X; a, b) = X^2 + aX + b.$$

The set of elements (a, b) such that $g(X; a, b) = 0$ has multiple roots is obviously closed. Therefore the continuity of ϕ implies (1). (2): First suppose that $f(X; \beta) = X^2 + aX + b$ is irreducible. Take an element $(a_1, b_1) \in \mathbb{Q}_p^2$ which is close to (a, b) . It follows by [Weil, XI, Lemma 1] that if (a_1, b_1) is sufficiently close to (a, b) , then $g(X; a_1, b_1)$ is also irreducible, and $g(X; a_1, b_1) = 0$ has a root α belonging to $\mathbb{Q}_p[\beta]$ and also to V . Therefore $\phi(V)$ includes an open neighborhood of $\phi(\beta) = (a, b)$. Next assume that $f(X; \beta)$ is reducible and put

$$f(X; \beta) = (X - u)(X - v) \quad (u, v \in \mathbb{Q}_p).$$

Since $u \neq v$ by assumption, B_p has a zero divisor, so that we may assume $B_p = M_2(\mathbb{Q}_p)$. A similar argument as in [Weil, XI, Lemma 1] implies that if (a_1, b_1) is sufficiently close to (a, b) , then $g(X; a_1, b_1) = 0$ has two roots u_1, v_1 in \mathbb{Q}_p , which are close to u, v , respectively. In particular, $u_1 \neq v_1$. Therefore, taking $\gamma \in B_p^\times$ so that

$$\gamma^{-1}\beta\gamma = \begin{bmatrix} u & 0 \\ 0 & v \end{bmatrix},$$

and putting

$$\alpha = \gamma \begin{bmatrix} u_1 & 0 \\ 0 & v_1 \end{bmatrix} \gamma^{-1},$$

we get $\alpha \in V$ and $f(X; \alpha) = g(X; a_1, b_1)$. This proves (2). □

Theorem 5.2.9. *Let B be an indefinite quaternion algebra over \mathbb{Q} , R a maximal order of B , and N a positive integer. Assume that for each prime factor p of N , an element β_p of B_p satisfying $N_B(\beta_p) = 1$ is given. Then there exists an element β of B satisfying the following three conditions:*

- (i) $N_B(\beta) = 1$;
- (ii) $\beta \equiv \beta_p \pmod{NR_p}$ if $p|N$;
- (iii) $\beta \in R_p$ if $p \nmid N$.

Proof. By Lemma 5.2.7, we may assume that

$$(5.2.3) \quad \beta_p \text{ is regular for each } p.$$

Let k be a positive integer satisfying

$$N^{k-1}\beta_p \in R_p$$

for all prime factors p of N , and $\{\varepsilon_1, \dots, \varepsilon_r\}$ a complete set of representatives of $(R/N^kR)^\times$. Note that

$$(R/NR)^\times \simeq \prod_{p|N} (R_p/N^kR_p)^\times,$$

since \mathbb{Z} is dense in $\prod_p \mathbb{Z}_p$. We see that

$$(5.2.4) \quad (B_\infty^\times \times \prod_p R_p^\times) \setminus B_A^\times / B^\times \text{ is a finite set.}$$

In fact, if B is a division quaternion algebra, then it follows from Lemma 5.2.4(5). Otherwise it can be verified directly. Let $\{\xi^{(1)}, \dots, \xi^{(s)}\}$ be a complete set of representatives of $(B_\infty^\times \times \prod_p R_p^\times) \setminus B_A^\times / B^\times$. As is easily seen, we can take all $\xi^{(j)} = (\xi_v^{(j)})$ so that $\xi_p^{(j)} = 1$ for all prime factors p of N .

Now let L be a positive integer such that for all prime numbers p prime to L ,

$$(5.2.5) \quad B_p \simeq M_2(\mathbb{Q}_p), \quad \varepsilon_i \in R_p^\times \quad (1 \leq i \leq r), \quad \xi_p^{(j)} \in R_p^\times \quad (1 \leq j \leq s).$$

Moreover take a positive integer h so that

$$(5.2.6) \quad L^h(\xi_p^{(j)} \varepsilon_i^{-1})^{-1} R_p \xi_p^{(j)} \varepsilon_i^{-1} \subset R_p$$

for all i and j and all prime factors p of L . For each prime number p which divides L but is prime to N , we can take an element β_p of B_p by Lemma 5.2.6 so that

$$(5.2.7) \quad N_B(\beta_p) = 1, \quad \beta_p \text{ is regular, and } \beta_p \equiv 1 \pmod{L^h R_p}.$$

Hence a regular element β_p of B_p has been given for each prime factor p of LN .

By Lemma 5.2.8(1), we can take a neighborhood U_p of β_p so that

$$U_p \subset \beta_p + L^h N^k R_p$$

and all elements of U_p are regular. Take $(a, 1) \in \mathbb{Q}^2$ so that

$$(5.2.8) \quad (a, 1) \in \begin{cases} \phi(U_p) & (p|LN), \\ \mathbb{Z}_p \times \mathbb{Z}_p & (p \nmid LN), \end{cases}$$

and put

$$g(X) = X^2 - aX + 1.$$

By assumption, $g(X)$ is a principal polynomial of an element of B_p for all p . Furthermore since B is indefinite, $g(X)$ is also a principal polynomial of an element of $B_\infty (= M_2(\mathbb{R}))$. Therefore by Lemma 5.2.5, there exists an element α in B such that $g(X) = f(X; \alpha)$.

For each prime factor p of LN , there exists $\alpha_p \in U_p$ such that

$$g(X) = f(X; \alpha_p).$$

Since $\alpha_p \in B_p^\times$ and $\alpha \in B^\times$, there exists an element γ_p of B_p^\times such that

$$\alpha = \gamma_p^{-1} \alpha_p \gamma_p$$

by Lemma 5.2.2.

Let p be a prime number prime to LN . Since $a \in \mathbb{Z}_p$, α is contained in a maximal order of B_p . Hence there exists an element γ_p of B_p^\times such that

$$\gamma_p \alpha \gamma_p^{-1} \in R_p,$$

since all maximal orders of B_p are conjugate to each other. We may assume

$$\gamma_p = 1$$

for almost all p , since α is contained in R_p for almost all p . We put

$$\gamma = (\gamma_v)$$

with the γ_p defined above and

$$\gamma_\infty = 1.$$

Then $\gamma \in B_A^\times$, so that we can write

$$\gamma = \eta \zeta^{(j)} \delta \quad (\eta = (\eta_v) \in B_\infty^\times \times \prod_p R_p^\times, \delta \in B^\times)$$

with some $\zeta^{(j)}$. By the choice of $\{\varepsilon_i\}$, there exists ε_i such that

$$(5.2.9) \quad \eta_p \varepsilon_i^{-1} \in 1 + N^k R_p \quad \text{for all prime factors } p \text{ of } N.$$

We put

$$\beta = (\varepsilon_i \delta) \alpha (\varepsilon_i \delta)^{-1}$$

and shall prove that β satisfies the three conditions in the theorem.

(i): Obviously $N_B(\beta) = 1$.

(ii): Suppose $p|N$. Since $\zeta_p^{(j)} = 1$, we have $\gamma_p = \eta_p \delta$, so that

$$\begin{aligned} \beta &= (\eta_p \varepsilon_i^{-1})^{-1} (\gamma_p \alpha \gamma_p^{-1}) (\eta_p \varepsilon_i^{-1}) \\ &= (\eta_p \varepsilon_i^{-1})^{-1} \alpha_p (\eta_p \varepsilon_i^{-1}). \end{aligned}$$

Therefore

$$\begin{aligned} \beta - \beta_p &= (\eta_p \varepsilon_i^{-1})^{-1} \alpha_p (\eta_p \varepsilon_i^{-1}) - \beta_p \\ &\equiv 0 \pmod{NR_p} \end{aligned}$$

by (5.2.9) and the choice of α_p and k .

(iii): First assume $p|L$ and $p \nmid N$. Then

$$\begin{aligned} \beta &= (\varepsilon_i \delta) \alpha (\varepsilon_i \delta)^{-1} \\ &= \varepsilon_i (\zeta_p^{(j)})^{-1} (\eta_p^{-1} \alpha_p \eta_p) \zeta_p^{(j)} \varepsilon_i^{-1}. \end{aligned}$$

Since $\alpha_p \in U_p$ and $\eta_p \in R_p^\times$, we see

$$\alpha_p \equiv \beta_p \equiv 1 \pmod{L^h R_p}$$

and

$$\eta_p^{-1} \alpha_p \eta_p \equiv 1 \pmod{L^h R_p}.$$

Since

$$\varepsilon_i(\xi_p^{(j)})^{-1} (L^h R_p) \xi_p^{(j)} \varepsilon_i^{-1} \subset R_p,$$

we obtain $\beta \in R_p$. Next suppose $p \nmid LN$. Then

$$\beta = (\varepsilon_i \delta \gamma_p^{-1}) (\gamma_p \alpha \gamma_p^{-1}) (\varepsilon_i \delta \gamma_p^{-1})^{-1},$$

and $\gamma_p \alpha \gamma_p^{-1} \in R_p$ by assumption. Since $\eta_p \in R_p^\times$ by definition, and $\varepsilon_i, \xi_p^{(j)} \in R_p^\times$ by (5.2.6), we see that

$$\varepsilon_i \delta \gamma_p^{-1} = \varepsilon_i (\eta_p \xi_p^{(j)})^{-1} \in R_p^\times.$$

Therefore $\beta \in R_p$. This completes the proof. \square

Theorem 5.2.10. (Approximation Theorem) *Let B be an indefinite quaternion algebra over \mathbb{Q} , R a maximal order of B , n an integer, and N a positive integer. Assume that for each prime factor p of N , an element β_p of R_p satisfies*

$$n/N_B(\beta_p) \equiv 1 \pmod{N\mathbb{Z}_p}.$$

Then there exists an element β of B satisfying

- (i) $N_B(\beta) = n$,
- (ii) $\beta \in R$,
- (iii) $\beta \equiv \beta_p \pmod{NR_p}$ for all prime factors p of N .

Proof. Since B is indefinite, there exists an element α of B^\times such that $N_B(\alpha) = n$ by [Weil, XI, Prop. 3]. Let L be the product of all prime numbers p such that $\alpha \notin R_p$. For each prime factor p of LN , we take an element δ_p of R_p as follows. First suppose $p \mid N$. We can take an element γ_p of R_p satisfying $\gamma_p - 1 \equiv 0 \pmod{NR_p}$ and $N_B(\gamma_p) = n/N_B(\beta_p)$ by Lemma 5.2.6. Put

$$\delta_p = \alpha^{-1} \gamma_p \beta_p \quad (p \mid N).$$

Note that $N_B(\delta_p) = 1$. Next assume $p \mid L$ and $p \nmid N$. We can take an element γ_p of R_p satisfying $N_B(\gamma_p) = n$ by Lemma 5.2.3(3). Put

$$\delta_p = \alpha^{-1} \gamma_p \quad (p \mid L, p \nmid N).$$

Note that $N_B(\delta_p) = 1$. Take a power M of LN so that

$$(5.2.10) \quad \alpha MR_p \subset NR_p \quad \text{for any prime factor } p \text{ of } LN.$$

We note that $NR_p = R_p$ if $p \nmid N$. Applying Theorem 5.2.9 by taking M and δ_p for N and β_p , respectively, we get an element δ of B so that

- (1) $N_B(\delta) = 1$,
- (2) if $p \mid M$, then $\delta \equiv \delta_p \pmod{MR_p}$,
- (3) if $p \nmid M$, then $\delta \in R_p$.

We put

$$\beta = \alpha \delta,$$

and are going to prove that β is what we want. It is obvious that $N_B(\beta) = n$. If $p|N$, then we see

$$\beta - \beta_p = \alpha\delta - \beta_p \equiv \alpha\delta_p - \beta_p \equiv (\gamma_p - 1)\beta_p \equiv 0 \pmod{NR_p}$$

by (2) and (5.2.10). This implies especially $\beta \in R_p$. If $p|L$ and $p \nmid N$, then by (2) and (5.2.10),

$$\beta - \gamma_p = \alpha\delta - \gamma_p \equiv \alpha\delta_p - \gamma_p = 0 \pmod{R_p}.$$

Since $\gamma_p \in R_p$, β belongs to R_p . Next suppose $p \nmid LN$. Then $\alpha \in R_p^\times$ and $\delta \in R_p$, so that $\beta \in R_p$. Therefore $\beta \in R$ by Lemma 5.2.4(4). \square

Theorem 5.2.11. *Let B be an indefinite quaternion algebra over \mathbb{Q} . If an order R of B satisfies that*

$$N_B(R_p^\times) = \mathbb{Z}_p^\times$$

for all prime numbers p , then

$$B_A^\times = B^\times \cdot \left(GL_2^+(\mathbb{R}) \times \prod_p R_p^\times \right).$$

Proof. Let $\beta = (\beta_v)$ be any element of B_A^\times . We shall show that β belongs to the set of the right-hand side. We may assume that $\beta_p \in R_p$ for all prime numbers p by multiplying an integer, if necessary. Since

$$\mathbb{Q}_A^\times = \mathbb{Q}^\times \cdot \left(\mathbb{R}_+^\times \times \prod_p \mathbb{Z}_p^\times \right),$$

we can write

$$N_B(\beta) = nu \quad \left(n \in \mathbb{Z}, u = (u_v) \in \mathbb{R}_+^\times \times \prod_p \mathbb{Z}_p^\times \right).$$

For each prime number p , there exists an element γ_p of R_p^\times satisfying $N_B(\gamma_p) = u_p$ by assumption. Put

$$\gamma_\infty = \begin{bmatrix} 1 & 0 \\ 0 & u_\infty \end{bmatrix}$$

and $\gamma = (\gamma_v) \in B_A^\times$. Then $\gamma \in GL_2^+(\mathbb{R}) \times \prod_p R_p^\times$ and $N_B(\gamma) = u$. Therefore we may assume $N_B(\beta) = n$ by taking $\beta\gamma^{-1}$ in place of β , if necessary. Let R_0 be a maximal order of B including R . For any prime number p such that $\beta_p \notin R_p^\times$ or $R_{0p} \neq R_p$, take a positive integer f so that

$$p^f \beta_p^{-1} R_{0p} \subset pR_p.$$

Put $N = \prod_p p^f$ with the above p and f . Applying Theorem 5.2.10 for N , n and β_p , we obtain an element α of R_0 satisfying

$$N_B(\alpha) = n, \quad \alpha \equiv \beta_p \pmod{NR_{0p}} \quad \text{if } p|N.$$

We have only to prove $\alpha^{-1}\beta \in GL_2^+(\mathbb{R}) \times \prod_p R_p^\times$. It is obvious $\alpha^{-1}\beta_\infty \in GL_2^+(\mathbb{R})$. If $p \nmid N$, then $n \in \mathbb{Z}_p^\times$ by definition, and we see $\alpha^{-1}\beta \in R_p^\times$. Next assume $p|N$. Since

$\alpha - \beta_p \in p^f R_{0p}$, we see

$$\beta_p^{-1} \alpha - 1 \in \beta_p^{-1} p^f R_{0p} \subset pR_p,$$

so that $\beta_p^{-1} \alpha \in R_p^\times$. This implies $\alpha^{-1} \beta \in GL_2^+(\mathbb{R}) \times \prod_p R_p^\times$. Since $\alpha \in B^\times$, we see $\beta \in GL_2^+(\mathbb{R}) \times \prod_p R_p^\times$. \square

We note that maximal orders and orders of Eichler type (for definition, see §5.3) of B satisfy the assumption of Theorem 5.2.11 by Lemma 5.2.3(3).

Theorem 5.2.12. *Let B be an indefinite quaternion algebra over \mathbb{Q} . All maximal orders of B are conjugate.*

Proof. Let R and S be two maximal orders of B . For each prime number p , there exists an element β_p of B_p^\times such that

$$S_p = \beta_p R_p \beta_p^{-1}$$

by Lemma 5.2.3(1), (2) and Lemma 5.2.4(1). Put $\beta = (\beta_p)$ with the above β_p and $\beta_\infty = 1$. Since $\beta \in B_A^\times$, we can write $\beta = \alpha u$ with $\alpha \in B^\times$ and $u \in GL_2^+(\mathbb{R}) \times \prod_p R_p^\times$ by Theorem 5.2.11, so that

$$S_p = \alpha R_p \alpha^{-1} = (\alpha R \alpha^{-1})_p.$$

Therefore we obtain $S = \alpha R \alpha^{-1}$ by Lemma 5.2.4(4). \square

Let B be an indefinite quaternion algebra over \mathbb{Q} . We fix an isomorphism of $B \otimes_{\mathbb{Q}} \mathbb{R}$ onto $M_2(\mathbb{R})$, and consider B as a subalgebra of $M_2(\mathbb{R})$ through this isomorphism. Then the norm $N_B(\beta)$ of an element β of B is nothing but the determinant of β as a matrix, by definition. Let R be an order of B . We put

$$(5.2.11) \quad \Gamma_R = \{ \beta \in R \mid N_B(\beta) = 1 \} \subset GL_2^+(\mathbb{R}),$$

and call it the *unit group of norm 1 of R* . We are going to prove that Γ_R is a Fuchsian group of the first kind.

Theorem 5.2.13. *Let B be an indefinite quaternion algebra over \mathbb{Q} , and R an order of B . Then Γ_R is a Fuchsian group of the first kind. Moreover, if B is a division quaternion algebra, then $\Gamma_R \backslash \mathbf{H}$ is compact.*

Proof. First suppose B is a division quaternion algebra. Since $\mathbf{H} \simeq SL_2(\mathbb{R})/SO_2(\mathbb{R})$ as topological spaces by Corollary 1.2.2, and $SO_2(\mathbb{R})$ is compact, the compactness of $\Gamma_R \backslash \mathbf{H}$ is equivalent to that of $\Gamma_R \backslash SL_2(\mathbb{R})$. Since

$$B_A^{(1)} \cap \left(GL_2(\mathbb{R}) \times \prod_p R_p^\times \right) = SL_2(\mathbb{R}) \times \prod_p R_p^\times,$$

$SL_2(\mathbb{R}) \times \prod_p R_p^\times$ is open in $B_A^{(1)}$. Put

$$W = B_A^{(1)} - B^\times \cdot \left(SL_2(\mathbb{R}) \times \prod_p R_p^\times \right).$$

Since W is a union of right $SL_2(\mathbb{R}) \times \prod_p R_p^\times$ -cosets, it is an open subset of $B_A^{(1)}$. Therefore $B^\times \setminus W$ is open in $B^\times \setminus B_A^{(1)}$. Since W is left B^\times -invariant, the complement of $B^\times \setminus W$ is $B^\times \setminus B^\times \cdot (SL_2(\mathbb{R}) \times \prod_p R_p^\times)$. Then it is a closed subset of a compact set $B^\times \setminus B_A^{(1)}$, so that it is compact. Since

$$B^\times \cap \left(SL_2(\mathbb{R}) \times \prod_p R_p^\times \right) \setminus \left(SL_2(\mathbb{R}) \times \prod_p R_p^\times \right) = B^\times \setminus B^\times \cdot \left(SL_2(\mathbb{R}) \times \prod_p R_p^\times \right)$$

and

$$B^\times \cap \left(SL_2(\mathbb{R}) \times \prod_p R_p^\times \right) = \Gamma_R$$

by Lemma 5.2.4(4), $\Gamma_R \setminus (SL_2(\mathbb{R}) \times \prod_p R_p^\times)$ is compact. Therefore $\Gamma_R \setminus SL_2(\mathbb{R})$ is compact since $\Gamma_R \setminus SL_2(\mathbb{R})$ is the image of $\Gamma_R \setminus (SL_2(\mathbb{R}) \times \prod_p R_p^\times)$ by the natural mapping. Next assume that B is not a division algebra. We may assume that $B = M_2(\mathbb{Q})$ by (5.2.1). Let R_0 be a maximal order of B including R . Since R_0 is conjugate to $M_2(\mathbb{Z})$ by Theorem 5.2.12, R_0 has an element of norm -1 , so that R_0 is conjugate to $M_2(\mathbb{Z})$ by an element of positive norm. Therefore we may assume

$$\Gamma_{R_0} = SL_2(\mathbb{Z}).$$

Since R and R_0 are commensurable as modules, there exists a positive integer N such that

$$NR_0 \subset R,$$

hence

$$1 + NR_0 \subset R$$

and

$$SL_2(\mathbb{Z}) \supset \Gamma_R \supset \Gamma(N).$$

This implies that $SL_2(\mathbb{Z})$ and Γ_R are commensurable, and Γ_R is a Fuchsian group of the first kind. □

§ 5.3. Hecke Algebras of Unit Groups of Quaternion Algebras

In the previous section, we proved that any unit group Γ_R of norm 1 of an order R of an indefinite quaternion algebra B over \mathbb{Q} is a Fuchsian group of the first kind. In this section, we study Hecke algebras of Γ_R .

Lemma 5.3.1. *For a non-negative integer e , we put*

$$R_p = \left\{ \begin{bmatrix} a & b \\ p^e c & d \end{bmatrix} \in M_2(\mathbb{Z}_p) \mid a, b, c, d \in \mathbb{Z}_p \right\}.$$

Then R_p is an order of $M_2(\mathbb{Q}_p)$. Moreover if $e \geq 1$, then we can write

$$R_p = R_p^{(1)} \cap R_p^{(2)}$$

with two maximal orders $R_p^{(1)}$ and $R_p^{(2)}$ of $M_2(\mathbb{Q}_p)$. The pair $(R_p^{(1)}, R_p^{(2)})$ is uniquely determined by R_p .

Proof. It is obvious that R_p is an order and

$$R_p = M_2(\mathbb{Z}_p) \cap \begin{bmatrix} p^e & 0 \\ 0 & 1 \end{bmatrix}^{-1} M_2(\mathbb{Z}_p) \begin{bmatrix} p^e & 0 \\ 0 & 1 \end{bmatrix}.$$

Let us study maximal orders including R_p . Any maximal order of $M_2(\mathbb{Q}_p)$ is given by $\beta^{-1} M_2(\mathbb{Z}_p) \beta$ ($\beta \in GL_2(\mathbb{Q}_p)$) by Lemma 5.2.3(2). Since

$$M_2(\mathbb{Q}_p) = \mathbb{Q}_p \cdot M_2(\mathbb{Z}_p),$$

we may assume $\beta \in M_2(\mathbb{Z}_p) \cap GL_2(\mathbb{Q}_p)$. Furthermore for any $\gamma \in GL_2(\mathbb{Z}_p)$ ($= M_2(\mathbb{Z}_p)^\times$), we have

$$(\gamma\beta)^{-1} M_2(\mathbb{Z}_p) \gamma\beta = \beta^{-1} M_2(\mathbb{Z}_p) \beta,$$

so that the set of all maximal orders of $M_2(\mathbb{Q}_p)$ is given by

$$\{ \beta^{-1} M_2(\mathbb{Z}_p) \beta \mid \beta \in GL_2(\mathbb{Z}_p) \setminus (GL_2(\mathbb{Q}_p) \cap M_2(\mathbb{Z}_p)) \}.$$

Now we can take the set of matrices of the following two types as a complete set of representatives of $GL_2(\mathbb{Z}_p) \setminus (GL_2(\mathbb{Q}_p) \cap M_2(\mathbb{Z}_p))$:

$$p^g \begin{bmatrix} 1 & u \\ 0 & p^f \end{bmatrix}, \quad p^g \begin{bmatrix} p^f & 0 \\ 0 & 1 \end{bmatrix},$$

where f and g are non-negative integers, and u runs over the representatives of $\mathbb{Z}_p/p^f \mathbb{Z}_p$. Since

$$\beta^{-1} \begin{bmatrix} a & b \\ c & d \end{bmatrix} \beta = \begin{bmatrix} a - cup^{-f} & au - cu^2 p^{-f} + bp^f - du \\ cp^{-f} & d + cup^{-f} \end{bmatrix}$$

for $\beta = \begin{bmatrix} 1 & u \\ 0 & p^f \end{bmatrix}$ ($f \geq 1$), we see easily that $\begin{bmatrix} 0 & 1 \\ 0 & 0 \end{bmatrix} \notin \beta^{-1} M_2(\mathbb{Z}_p) \beta$. Therefore any

maximal order including R_p is given by

$$\begin{bmatrix} p^f & 0 \\ 0 & 1 \end{bmatrix}^{-1} M_2(\mathbb{Z}_p) \begin{bmatrix} p^f & 0 \\ 0 & 1 \end{bmatrix} = \left\{ \begin{bmatrix} a & bp^{-f} \\ cp^f & d \end{bmatrix} \mid a, b, c, d \in \mathbb{Z}_p \right\} \quad (0 \leq f \leq e).$$

In particular, a pair $(R_p^{(1)}, R_p^{(2)})$ of maximal orders such that $R_p^{(1)} \cap R_p^{(2)} = R_p$ is uniquely given by

$$\left(M_2(\mathbb{Z}_p), \begin{bmatrix} p^e & 0 \\ 0 & 1 \end{bmatrix}^{-1} M_2(\mathbb{Z}_p) \begin{bmatrix} p^e & 0 \\ 0 & 1 \end{bmatrix} \right). \quad \square$$

Let B be an indefinite quaternion algebra over \mathbb{Q} . We denote by d_B the square of the product of all prime numbers p such that B_p is a division quaternion algebra, and call it the *discriminant* of B . We understand $d_B = 1$ if $B = M_2(\mathbb{Q})$. Let N be a positive integer prime to d_B . We say that an order R of B is of *Eichler type of level N* ,

or simply of level N , if the following two conditions are satisfied:

(i) if $p \nmid N$, then R_p is a maximal order of B_p ;

(ii) let $N = \prod p^e$ be the prime decomposition. If $p|N$, then R_p is conjugate to an order

$$\left\{ \left[\begin{array}{cc} a & b \\ p^e c & d \end{array} \right] \in M_2(\mathbb{Z}_p) \mid a, b, c, d \in \mathbb{Z}_p \right\}.$$

Let B be an indefinite quaternion algebra over \mathbb{Q} of discriminant d_B , and R an order of level N . For each prime number p prime to d_B , we fix an isomorphism of B_p onto $M_2(\mathbb{Q}_p)$ under which

$$(5.3.1) \quad R_p \simeq \begin{cases} M_2(\mathbb{Z}_p) & (p \nmid Nd_B), \\ \left\{ \left[\begin{array}{cc} a & b \\ p^e c & d \end{array} \right] \in M_2(\mathbb{Z}_p) \mid a, b, c, d \in \mathbb{Z}_p \right\} & (p|N). \end{cases}$$

We define the subgroup U_R of B_A^\times by

$$(5.3.2) \quad U_R = GL_2^+(\mathbb{R}) \times \prod_p R_p^\times.$$

Let S be a maximal order of B including R . Then

$$B_A^\times = B^\times \cdot U_R = B^\times \cdot U_S$$

by Theorem 5.2.11, and

$$\Gamma_R = U_R \cap B^\times, \quad \Gamma_S = U_S \cap B^\times.$$

Therefore

$$(U_S \cap B^\times) \cdot U_R = U_S$$

and

$$|\Gamma_S/\Gamma_R| = |U_S \cap B^\times / U_R \cap B^\times| = |U_S/U_R| = \prod_{p|N} |S_p^\times/R_p^\times|.$$

A similar (and easier) argument as in Theorem 4.2.5(2) implies

$$|S_p^\times/R_p^\times| = p^e(1 + 1/p).$$

Thus we obtain the following lemma which is a generalization of Theorem 4.2.5(2).

Lemma 5.3.2. *Let B be an indefinite quaternion algebra over \mathbb{Q} , and R an order of level N . If S is a maximal order of B including R , then*

$$[\Gamma_S : \Gamma_R] = N \prod_{p|N} (1 + 1/p).$$

We define the subsemigroup D_R of B_A^\times by

$$(5.3.3) \quad D_R = \left(GL_2^+(\mathbb{R}) \times \prod_p D_p \right) \cap B_A^\times,$$

where

$$(5.3.4) \quad D_p = \begin{cases} \{g \in R_p \mid N_B(g) \neq 0\} & (p \nmid N), \\ \left\{ \begin{bmatrix} a & b \\ p^e c & d \end{bmatrix} \in R_p \mid a \in \mathbb{Z}_p^\times, ad - p^e bc \neq 0 \right\} & (p \mid N). \end{cases}$$

Moreover put

$$(5.3.5) \quad \Delta_R = R \cap D_R.$$

Then the following lemma can be proved by a similar argument as in Lemma 4.5.2 for $p \nmid d_B$, and directly by Lemma 5.2.3(1) for $p \mid d_B$.

Lemma 5.3.3. *The notation being as above, we have*

$$D_p = \begin{cases} \prod_{0 \leq l \leq m} R_p^\times \begin{bmatrix} p^l & 0 \\ 0 & p^m \end{bmatrix} R_p^\times & (p \nmid Nd_B), \\ \prod_{0 \leq m} R_p^\times \begin{bmatrix} 1 & 0 \\ 0 & p^m \end{bmatrix} R_p^\times & (p \mid N), \\ \prod_{0 \leq m} R_p^\times \pi_p^m R_p^\times & (p \mid d_B), \end{cases}$$

where $\pi_p(p \mid d_B)$ is a prime element of B_p , and

$$R_p^\times \pi_p^m R_p^\times = R_p^\times \pi_p^m = \pi_p^m R_p^\times.$$

Lemma 5.3.4. (1) $g_p R_p^\times g_p^{-1} \approx R_p^\times$ for $g_p \in B_p^\times$;

(2) $g U_R g^{-1} \approx U_R$ for $g \in B_A^\times$;

(3) $\alpha \Gamma_R \alpha^{-1} \approx \Gamma_R$ for $\alpha \in B^\times$.

Proof. (1): Since R_p^\times and $g_p R_p^\times g_p^{-1}$ are open compact subgroups of B_p^\times , we see $g_p R_p^\times g_p^{-1} \approx R_p^\times$. (2): Let $g = (g_v) \in B_A^\times$. Then

$$g_p R_p^\times g_p^{-1} = R_p^\times$$

for almost all prime numbers p , and

$$g_\infty GL_2^+(\mathbb{R}) g_\infty^{-1} = GL_2^+(\mathbb{R}).$$

This combined with (1) implies (2). (3): Since

$$\Gamma_R = U_R \cap B^\times,$$

(2) implies that

$$|(\alpha \Gamma_R \alpha^{-1} \cap \Gamma_R) \setminus \Gamma_R| \leq |(\alpha U_R \alpha^{-1} \cap U_R) \setminus U_R| < \infty$$

and

$$|(\alpha \Gamma_R \alpha^{-1} \cap \Gamma_R) \setminus \alpha \Gamma_R \alpha^{-1}| \leq |(\alpha U_R \alpha^{-1} \cap U_R) \setminus \alpha U_R \alpha^{-1}| < \infty.$$

This proves (3). □

The above lemma enable us to define the Hecke algebras $\mathcal{H}(\Gamma_R, \Delta_R)$, $\mathcal{H}(U_R, D_R)$, and $\mathcal{H}(R_p^\times, D_p)$. Now let χ be a Dirichlet character mod N . Since

$$(\mathbb{Z}/N\mathbb{Z})^\times \simeq \prod_{p|N} (\mathbb{Z}_p/N\mathbb{Z}_p)^\times,$$

χ induces a character of $(\mathbb{Z}_p/N\mathbb{Z}_p)^\times$ which we denote by χ_p . For an element $g = (g_v)$ of D_R , we put

$$(5.3.6) \quad \chi(g) = \prod_{p|N} \bar{\chi}_p(a_p), \quad \left(g_p = \begin{bmatrix} a_p & b_p \\ c_p & d_p \end{bmatrix} \right).$$

Since

$$\Gamma_R \subset \Delta_R \subset D_R,$$

we also denote the restriction of χ on Δ_R or Γ_R by the same symbol χ . Then χ satisfies (2.8.1), and therefore, the Hecke algebra $\mathcal{H}(\Gamma_R, \Delta_R)$ acts on $\mathcal{G}_k(\Gamma_R, \chi)$. In particular, if $B = M_2(\mathbb{Q})$ and

$$R = \left\{ \begin{bmatrix} a & b \\ c & d \end{bmatrix} \in M_2(\mathbb{Z}) \mid c \equiv 0 \pmod{N} \right\},$$

then

$$\Gamma_R = \Gamma_0(N), \quad \Delta_R = \Delta_0(N), \quad \text{and} \quad \mathcal{G}_k(\Gamma_R, \chi) = \mathcal{G}_k(N, \chi).$$

Next we denote by $\otimes_p \mathcal{H}(R_p^\times, D_p)$ the tensor product of $\mathcal{H}(R_p^\times, D_p)$ taken over all prime numbers p . The relation between the Hecke algebra of Γ_R and local Hecke algebras is given by the following

Theorem 5.3.5. (1) *By the correspondence “ $\Gamma_R \alpha \Gamma_R \mapsto U_R \alpha U_R$ ”,*

$$\mathcal{H}(\Gamma_R, \Delta_R) \simeq \mathcal{H}(U_R, D_R)$$

(2) *By the correspondence “ $U_R g U_R \mapsto \otimes_p R_p^\times g_p R_p^\times$ ” ($g = (g_v)$),*

$$\mathcal{H}(U_R, D_R) \simeq \otimes_p \mathcal{H}(R_p^\times, D_p).$$

Proof. (1): Since Γ_R and Δ_R are embedded in B_A^\times by the canonical injection of R into B_A , we have only to verify conditions (i), (ii), (iii) of Theorem 2.7.6(1). Let S be a maximal order of B including R . First we verify condition (i) or $D_R = U_R \Delta_R$. Let $g = (g_v)$ be an element of D_R , and n a positive integer such that

$$n/N_B(g) \in \mathbb{Z}_p^\times \text{ for each prime number } p.$$

There exists an element h_p of R_p^\times such that

$$N_B(h_p) = n/N_B(g_p);$$

which is shown by Lemma 5.2.3(3) if $p \mid d_B$, and directly if $p \nmid d_B$. Put $h_\infty = 1$ and $h = (h_v)$. Then $h \in U_R$. If p is a prime factor of nN , then we take a positive integer f so that

$$(5.3.7) \quad p^f S_p(h_p g_p)^{-1} \subset pR_p.$$

Put $M = \prod_p p^f$. By applying Theorem 5.2.10 for $M, n, h_p g_p$, there exists an element β of S such that $N_B(\beta) = n$ and

$$(5.3.8) \quad \beta \equiv h_p g_p \pmod{MS_p} \quad \text{if } p|M.$$

If $p|M$, then by (5.3.7) and (5.3.8),

$$\beta(h_p g_p)^{-1} - 1 = (\beta - h_p g_p)(h_p g_p)^{-1} \in pR_p,$$

so that $\beta(h_p g_p)^{-1} \in R_p^\times$. In particular, $\beta \in D_p$. If $p \nmid M$, then $S_p = R_p, g_p \in R_p^\times$, and $\beta \in S_p^\times$, so that $\beta \in R_p^\times$ and $\beta(h_p g_p)^{-1} \in R_p^\times$. Therefore $\beta \in R$ by Lemma 5.2.4(4), so that $\beta \in \Delta_R$ and $\beta(hg)^{-1} \in U_R$. Thus $D_R = U_R \Delta_R$.

Next let us prove (ii), or $U_R \alpha U_R = U_R \alpha \Gamma_R$ for any $\alpha \in \Delta_R$. It is sufficient to prove that $\alpha h \in U_R \alpha \Gamma_R$ for any $h = (h_v) \in U_R$. For each prime number p prime to d_B , there exist $\delta_p, \varepsilon_p \in R_p^\times$ such that

$$\delta_p \alpha \varepsilon_p = \begin{bmatrix} p^l & 0 \\ 0 & p^m \end{bmatrix} \quad (0 \leq l \leq m)$$

by Lemma 5.3.3. We put

$$(5.3.9) \quad w_v = \begin{cases} \varepsilon_p \begin{bmatrix} N_B(h_p^{-1}) & 0 \\ 0 & 1 \end{bmatrix} \varepsilon_p^{-1} & (v = p, p \nmid d_B), \\ h_p^{-1} & (v = p, p|d_B), \\ 1 & (v = \infty), \end{cases}$$

and $w = (w_v)$. Then $w \in U_R$ and $\alpha \in U_R \alpha w$. For a prime factor p of $N_B(\alpha)$ or a prime number p satisfying $S_p \neq R_p$, we take a positive integer f so that

$$(5.3.10) \quad p^f (\alpha S_p (w_p h_p)^{-1} \alpha^{-1}) \subset pR_p, \quad \text{and} \quad p^f S_p \subset R_p.$$

We put $M = \Pi p^f$ and apply Theorem 5.2.10 for $M, 1, w_p h_p$. Then there exists an element γ in S such that $N_B(\gamma) = 1$ and

$$(5.3.11) \quad \gamma \equiv w_p h_p \pmod{MS_p} \quad \text{if } p|M.$$

Since $w_p h_p \in R_p$ and $\gamma - w_p h_p \in MS_p \subset R_p$, γ belongs to R , and therefore, to Γ_R . Now we define $z \in B_A^\times$ by

$$\alpha \gamma = z \alpha w h.$$

If $p \nmid M$, then obviously $z_p \in R_p^\times$. Otherwise we see by (5.3.10) and (5.3.11)

$$\begin{aligned} z_p - 1 &= \alpha (\gamma (w_p h_p)^{-1} - 1) \alpha^{-1} \\ &= \alpha (\gamma - w_p h_p) (w_p h_p)^{-1} \alpha^{-1} \in pR_p. \end{aligned}$$

Therefore $z \in U_R$ and

$$\alpha w h = z^{-1} \alpha \gamma \in U_R \alpha \Gamma_R.$$

This implies

$$\alpha h \in U_R \alpha w h \subset U_R \alpha \Gamma_R,$$

and (ii) is proved. The third condition that $U_{R\alpha} \cap \Delta_R = \Gamma_R \alpha$ for any $\alpha \in \Delta_R$ is obviously satisfied.

(2): This is obvious by the definition of adelization. □

Theorem 5.3.6. *For any prime number p , $\mathcal{R}(R_p^\times, D_p)$ is commutative. Furthermore*

(1) *if $p \nmid Nd_B$, then*

$$\mathcal{R}(R_p^\times, D_p) = \mathbb{Z} \left[R_p^\times \begin{bmatrix} 1 & 0 \\ 0 & p \end{bmatrix} R_p^\times, R_p^\times \begin{bmatrix} p & 0 \\ 0 & p \end{bmatrix} R_p^\times \right],$$

and for any positive integers e and f ,

$$\begin{aligned} & \left(R_p^\times \begin{bmatrix} 1 & 0 \\ 0 & p \end{bmatrix} R_p^\times \right) \left(R_p^\times \begin{bmatrix} 1 & 0 \\ 0 & p^e \end{bmatrix} R_p^\times \right) \\ &= R_p^\times \begin{bmatrix} 1 & 0 \\ 0 & p^{e+1} \end{bmatrix} R_p^\times \\ &+ \begin{cases} (p+1) \left(R_p^\times \begin{bmatrix} p & 0 \\ 0 & p \end{bmatrix} R_p^\times \right) & (e = 1), \\ p \left(R_p^\times \begin{bmatrix} p & 0 \\ 0 & p \end{bmatrix} R_p^\times \right) \left(R_p^\times \begin{bmatrix} 1 & 0 \\ 0 & p^{e-1} \end{bmatrix} R_p^\times \right) & (e > 1), \end{cases} \\ & \left(R_p^\times \begin{bmatrix} p & 0 \\ 0 & p \end{bmatrix} R_p^\times \right) \left(R_p^\times \begin{bmatrix} p^e & 0 \\ 0 & p^f \end{bmatrix} R_p^\times \right) = R_p^\times \begin{bmatrix} p^{e+1} & 0 \\ 0 & p^{f+1} \end{bmatrix} R_p^\times; \end{aligned}$$

(2) *if $p \mid N$, then*

$$\mathcal{R}(R_p^\times, D_p) = \mathbb{Z} \left[R_p^\times \begin{bmatrix} 1 & 0 \\ 0 & p \end{bmatrix} R_p^\times \right],$$

and for any positive integer e ,

$$\left(R_p^\times \begin{bmatrix} 1 & 0 \\ 0 & p \end{bmatrix} R_p^\times \right) \left(R_p^\times \begin{bmatrix} 1 & 0 \\ 0 & p^e \end{bmatrix} R_p^\times \right) = R_p^\times \begin{bmatrix} 1 & 0 \\ 0 & p^{e+1} \end{bmatrix} R_p^\times;$$

(3) *if $p \mid d_B$, then*

$$\mathcal{R}(R_p^\times, D_p) = \mathbb{Z} [R_p^\times \pi_p R_p^\times],$$

and for any positive integer e ,

$$\begin{aligned} R_p^\times \pi_p^2 R_p^\times &= R_p^\times p R_p^\times, \\ (R_p^\times \pi_p R_p^\times) (R_p^\times \pi_p^e R_p^\times) &= R_p^\times \pi_p^{e+1} R_p^\times. \end{aligned}$$

Here π_p is a prime element of B_p .

Proof. The assertions for each p prime to d_B can be proved similarly to Theorem 4.5.3(1) and Lemma 4.5.7, respectively. (Since \mathbb{Z}_p is a local ring, these cases are easier

than the previous ones.) Suppose $p|d_B$. Any element of $\mathcal{R}(R_p^\times, D_p)$ can be written as a linear combination of $R_p^\times \pi_p^e R_p^\times$ ($0 \leq e \in \mathbb{Z}$) by Lemma 5.3.3. Since

$$R_p^\times \pi_p^e R_p^\times = R_p^\times \pi_p^e,$$

we get

$$(R_p^\times \pi_p R_p^\times)(R_p^\times \pi_p^e R_p^\times) = R_p^\times \pi_p^{e+1} R_p^\times$$

by definition. In particular, $\mathcal{R}(R_p^\times, D_p)$ is commutative. Since

$$R_p^\times \pi_p^2 = R_p^\times p,$$

we get

$$R_p^\times \pi_p^2 R_p^\times = R_p^\times p R_p^\times. \quad \square$$

For a positive integer n , we define the element $T(n)$ of $\mathcal{R}(\Gamma_R, \Delta_R)$ by

$$(5.3.12) \quad T(n) = \sum_{\substack{N_B(\alpha) = n \\ \alpha \in \Delta_R}} \Gamma_R \alpha \Gamma_R,$$

where the summation is taken over all double cosets $\Gamma_R \alpha \Gamma_R$ with $N_B(\alpha) = n$. Moreover for a positive integer n prime to N , we put

$$(5.3.13) \quad T(n, n) = \Gamma_R n \Gamma_R.$$

We consider $\mathcal{R}(R_p^\times, D_p)$ as a subring of $\otimes_p \mathcal{R}(R_p^\times, D_p)$ by the natural injection. Then by the isomorphism of $\mathcal{R}(\Gamma_R, \Delta_R)$ onto $\otimes_p \mathcal{R}(R_p^\times, D_p)$ in Theorem 5.3.5, we have the following conditions:

1° if $p \nmid Nd_B$, then $T(p^l)$ and $T(p, p)$ correspond to

$$\sum_{\substack{e+f=l \\ 0 \leq e \leq f}} R_p^\times \begin{bmatrix} p^e & 0 \\ 0 & p^f \end{bmatrix} R_p^\times,$$

and

$$R_p^\times p R_p^\times,$$

respectively;

2° if $p|N$, then $T(p^l)$ corresponds to $R_p^\times \begin{bmatrix} 1 & 0 \\ 0 & p^l \end{bmatrix} R_p^\times$;

3° if $p|d_B$, then $T(p^l)$ corresponds to $R_p^\times \pi_p^l R_p^\times$.

Consequently we obtain the following

Corollary 5.3.7. $\mathcal{R}(\Gamma_R, \Delta_R)$ is commutative, and

$$\mathcal{R}(\Gamma_R, \Delta_R) = \mathbb{Z}[T(p), T(p, p), T(q) | p \nmid Nd_B, q | Nd_B]$$

Moreover we have:

(1) if $(n, m) = 1$, then $T(n)T(m) = T(nm)$;

(2) $T(p)T(p^e) = \begin{cases} T(p^{e+1}) + pT(p, p)T(p^{e-1}) & (p \nmid Nd_B), \\ T(p^{e+1}) & (p | Nd_B). \end{cases}$

Similarly to the case of modular groups, we define a formal Dirichlet series with coefficients in $\mathcal{R}(\Gamma_R, \Delta_R)$ by

$$(5.3.14) \quad D(s) = \sum_{n=1}^{\infty} T(n)n^{-s}.$$

Then Corollary 5.3.7 is equivalent to the formal Euler product:

$$(5.3.15) \quad D(s) = \prod_{p \nmid Nd_B} (1 - T(p)p^{-s} + pT(p, p)p^{-2s})^{-1} \\ \times \prod_{p \mid Nd_B} (1 - T(p)p^{-s})^{-1}.$$

Now let α be an element of B^\times . If B_v is isomorphic to $M_2(\mathbb{Q}_v)$, then

$$\det(\alpha)\alpha^{-1} = N_B(\alpha)\alpha^{-1}$$

under the natural embedding of B into B_v , so that $\det(\alpha)\alpha^{-1}$ is independent of the choice of v . Therefore by a similar argument as in Theorem 4.5.4, we obtain

Theorem 5.3.8. (1) If $(n, N) = 1$, then the Hecke operators $T(n)$ and $\bar{\chi}(n)T(n)$ on $\mathcal{S}_k(\Gamma_R, \chi)$ are adjoint operators with respect to the Petersson inner product.

(2) $\mathcal{S}_k(\Gamma_R, \chi)$ has a basis consisting of common eigenfunctions of $T(n)$ ($(n, N) = 1$).

Here χ is a Dirichlet character mod N .

Chapter 6. Traces of Hecke Operators

The Fourier coefficients of Eisenstein series are quite simple, since they are derived from Dirichlet L -functions. To the contrary, the Fourier coefficients of cusp forms, or equivalently the eigen values of Hecke operators are quite mysterious and play important roles in applications of modular forms to number theory (for example, see [Shimura 4] and [Shimura 6]). To obtain eigen values of Hecke operators $T(n)$ operating on $\mathcal{S}_k(N, \chi)$, we have only to calculate the traces $\text{tr}(T(m))$ of $T(m)$ on $\mathcal{S}_k(N, \chi)$ for finitely many m 's (see the end of this chapter).

In this chapter, we calculate them by the method of Selberg. We refer [Godement] for §6.1 through §6.3, [Shimizu 2] for §6.4, and [Hijikata] for §6.5 through §6.8.

§ 6.1. Spaces of Functions on \mathbf{H}

Let k be a non-negative number. Let p be either a real number such that $1 \leq p < \infty$ or ∞ . We call such p an *exponent*. For a complex valued function $f(z)$ on \mathbf{H} , we put

$$\|f\|_p = \begin{cases} \left\{ \int_{\mathbf{H}} |f(z) \text{Im}(z)^{k/2}|^p dv(z) \right\}^{1/p} & (1 \leq p < \infty), \\ \text{ess. sup}_{z \in \mathbf{H}} |f(z) \text{Im}(z)^{k/2}| & (p = \infty). \end{cases}$$

Here $\|f\|_\infty = m$ implies that the set $\{z \in \mathbf{H} \mid |f(z)| \text{Im}(z)^{k/2} > m\}$ has measure 0 and the set $\{z \in \mathbf{H} \mid |f(z)| \text{Im}(z)^{k/2} > m - \varepsilon\}$ has non-zero measure for any positive number ε . We denote by $L_k^p(\mathbf{H})$ the space of all measurable functions f on \mathbf{H} satisfying $\|f\|_p < \infty$. In particular, $L_0^p(\mathbf{H})$ is the L^p -space of functions on \mathbf{H} in the usual sense. Hence it is a Banach space. Since $L_k^p(\mathbf{H})$ is isomorphic to $L_0^p(\mathbf{H})$ as normed spaces by the map " $f(z) \mapsto f(z) \text{Im}(z)^{k/2}$ ", $L_k^p(\mathbf{H})$ is also a Banach space for any k . We call two exponents p and q are *conjugate*, if they satisfy that

$$\frac{1}{p} + \frac{1}{q} = 1.$$

Here we understand $1/p = 0$ if $p = \infty$. If p and q are conjugate exponents, we put

for $f \in L_k^p(\mathbf{H})$ and $g \in L_k^q(\mathbf{H})$,

$$(6.1.1) \quad (f, g)_{\mathbf{H}} = \int_{\mathbf{H}} f(z) \overline{g(z)} \operatorname{Im}(z)^k dv(z).$$

By this pairing, an element g of $L_k^q(\mathbf{H})$ can be identified with an element of the dual space of $L_k^p(\mathbf{H})$, or the space of all continuous linear functionals of $L_k^p(\mathbf{H})$. Further if $p \neq \infty$, $L_k^q(\mathbf{H})$ is considered as the dual space of $L_k^p(\mathbf{H})$ by this identification. Further $L_k^2(\mathbf{H})$ is a Hilbert space with the inner product given by (6.1.1). We also denote by $H_k^p(\mathbf{H})$ the subspace consisting of holomorphic functions in $L_k^p(\mathbf{H})$.

Theorem 6.1.1. *The space $H_k^p(\mathbf{H})$ is a closed subspace of $L_k^p(\mathbf{H})$.*

Proof. Let $f(z)$ be the limit of a sequence $\{f_n(z)\}$ in $H_k^p(\mathbf{H})$. Applying Corollary 2.6.4, we see that $f(z)$ is also holomorphic. \square

Let H be a Hilbert space consisting of complex valued functions on a set X . We denote by (f, g) ($f, g \in H$) the inner product of H . We call a function $K(x, y)$ on $X \times X$ a *kernel function* of H if it satisfies the following two conditions:

(6.1.2) *as a function of x , $K(x, y)$ belongs to H for each fixed y ;*

(6.1.3) *for any element $f(x)$ of H ,*

$$f(y) = (f(x), K(x, y)) \quad (y \in X),$$

where the right-hand side is the inner product as functions of x .

If $K(x, y)$ is a kernel function, then we see easily

$$(6.1.4) \quad K(x, y) = \overline{K(y, x)}.$$

Kernel functions do not necessarily exist. However, if it exists, it is uniquely determined. Furthermore, if H is finite dimensional, then it has the kernel function given by

$$K(x, y) = \sum_{v=1}^d f_v(x) \overline{f_v(y)}, \quad (x, y \in X),$$

where $\{f_1, \dots, f_d\}$ is an orthonormal basis of H .

Now we shall show the existence of the kernel function of $H_k^2(\mathbf{H})$ and calculate the explicit form. By Corollary 2.6.2, there exists a constant C depending only on $z \in \mathbf{H}$ and k such that

$$|f(z)| \leq C \|f\|_2 \quad (f \in H_k^2(\mathbf{H})).$$

Therefore, for each fixed $z_0 \in \mathbf{H}$, the map " $f \mapsto f(z_0)$ " is a continuous linear functional of $H_k^2(\mathbf{H})$. Since $H_k^2(\mathbf{H})$ is a Hilbert space, there exists a unique element $g_{z_0} \in H_k^2(\mathbf{H})$ satisfying

$$f(z_0) = (f, g_{z_0})_{\mathbf{H}}.$$

Put $K_k(z_1, z_2) = g_{z_2}(z_1)$ for $z_1, z_2 \in \mathbf{H}$. Then it is the kernel function of $H_k^2(\mathbf{H})$ and

$$f(z) = \int_{\mathbf{H}} K_k(z, z_2) f(z_2) \operatorname{Im}(z_2)^k dv(z_2) \quad \text{for any } f \in H_k^2(\mathbf{H}).$$

Let α be an element of $SL_2(\mathbb{R})$. For any $f \in H_k^2(\mathbf{H})$, the function $f(\alpha z)j(\alpha, z)^{-k}$ belongs to $H_k^2(\mathbf{H})$. Since the measure $dv(z)$ of \mathbf{H} is invariant under the action of $SL_2(\mathbb{R})$, we see for any $f \in H_k^2(\mathbf{H})$

$$\begin{aligned} & \int_{\mathbf{H}} K_k(\alpha z_1, \alpha z_2) j(\alpha, z_1)^{-k} \overline{j(\alpha, z_2)^{-k}} f(z_2) \text{Im}(z_2)^k dv(z_2) \\ &= j(\alpha, z_1)^{-k} \int_{\mathbf{H}} K_k(\alpha z_1, z_2) f(\alpha^{-1} z_2) j(\alpha, \alpha^{-1} z_2)^k \text{Im}(z_2)^k dv(z_2) \\ &= j(\alpha, z_1)^{-k} f(z_1) j(\alpha, z_1)^k = f(z_1). \end{aligned}$$

By the uniqueness of the kernel function, we have

$$(6.1.5) \quad K_k(\alpha z_1, \alpha z_2) = K_k(z_1, z_2) j(\alpha, z_1)^k \overline{j(\alpha, z_2)^k} \quad (\alpha \in SL_2(\mathbb{R})),$$

and

$$(6.1.6) \quad K_k(\alpha z_1, z_2) j(\alpha, z_1)^{-k} = K_k(z_1, \alpha^{-1} z_2) \overline{j(\alpha^{-1}, z_2)^{-k}} \quad (\alpha \in SL_2(\mathbb{R})).$$

In particular, taking $\begin{bmatrix} 1 & b \\ 0 & 1 \end{bmatrix}$ ($b \in \mathbb{R}$) as α , we see

$$(6.1.7) \quad K_k(z_1 + b, z_2 + b) = K_k(z_1, z_2) \quad (b \in \mathbb{R}).$$

We put

$$M = \{(z_1, z_2) \in \mathbb{C}^2 \mid z_1 \in \mathbf{H}, \overline{z_1 - z_2} \in \mathbf{H}\},$$

and

$$h(z_1, z_2) = K_k(z_1, \overline{z_1 - z_2}) \quad ((z_1, z_2) \in M).$$

Then $h(z_1, z_2)$ is a holomorphic function on M . Since $h(z_1 + b, z_2) = h(z_1, z_2)$ for any $b \in \mathbb{R}$, $h(z_1, z_2)$ is independent of z_1 . For $z \in \mathbf{H}$, take $z_1 \in \mathbf{H}$ so that $(z_1, z) \in M$ and put

$$P_k(z) = h(z_1, z) = K_k(z_1, \overline{z_1 - z}).$$

Then $P_k(z)$ is a holomorphic function on \mathbf{H} and

$$K_k(z_1, z_2) = P_k(z_1 - \bar{z}_2) \quad (z_1, z_2 \in \mathbf{H}).$$

Take $\begin{bmatrix} a & 0 \\ 0 & a^{-1} \end{bmatrix}$ ($a \in \mathbb{R}^\times$) for α in (6.1.5), then we have $P_k(a^2 z) = a^{-2k} P_k(z)$. In particular,

$$P_k(iy) = y^{-k} P_k(i) \quad (y > 0).$$

Since $P_k(z)$ is holomorphic on \mathbf{H} , we see that

$$P_k(z) = c_k (z/2i)^{-k}$$

with a constant c_k . Thus we obtain the following

Theorem 6.1.2. *The Hilbert space $H_k^2(\mathbf{H})$ has the kernel function*

$$K_k(z_1, z_2) = c_k((z_1 - \bar{z}_2)/2i)^{-k}$$

with a constant c_k .

Corollary 6.1.3. $H_k^2(\mathbf{H}) \subset H_k^\infty(\mathbf{H})$.

Proof. Let $f(z)$ be an element in $H_k^2(\mathbf{H})$. For any point $z_0 \in \mathbf{H}$, we see that

$$\begin{aligned} |f(z_0)|^2 &= |(f(z), K_k(z, z_0))_{\mathbf{H}}|^2 \leq \|f\|_2^2 \cdot \|K_k(z, z_0)\|_2^2 \\ &= \|f\|_2^2 K_k(z_0, z_0) = c_k \operatorname{Im}(z_0)^{-k} \|f\|_2^2. \end{aligned}$$

This implies $|f(z_0)\operatorname{Im}(z_0)^{k/2}| \leq \sqrt{c_k} \|f\|_2$ for any $z_0 \in \mathbf{H}$, and therefore f belongs to $H_k^\infty(\mathbf{H})$. □

Let us calculate the constant c_k in Theorem 6.1.2. We denote by \mathbb{R}_+ and \mathbb{R}_- the set of all positive real numbers and the set of negative real numbers, respectively. For an element $f(z)$ in $H_k^2(\mathbf{H})$ and a point $y \in \mathbb{R}_+$, we put

$$f_y(x) = f(x + iy) \quad (x \in \mathbb{R}).$$

Since $\|f\|_2^2 = \int_{\mathbf{H}} |f(x + iy)|^2 y^{k-2} dx dy$ is finite, there exists a subset S_f of measure zero in \mathbb{R}_+ such that $f_y \in L^2(\mathbb{R})$ if $y \notin S_f$. Denote by $\hat{f}_y(u)$ the Fourier transform of f_y for $y \notin S_f$, or $\hat{f}_y(u) = \text{l.i.m.}_{n \rightarrow \infty} \int_{-n}^n f_y(x) e^{-2\pi i u x} dx$, where l.i.m. implies the limit in $L^2(\mathbb{R})$.

Theorem 6.1.4. (1) *For a function $f(z) \in H_k^2(\mathbf{H})$, there exists a function $\hat{f}(u)$ on \mathbb{R} satisfying*

$$\hat{f}_y(u) = \hat{f}(u) e^{-2\pi u y} \quad (y \notin S_f),$$

and $\hat{f}(u)$ vanishes almost everywhere on \mathbb{R}_- .

(2) *If $k \leq 1$, then $H_k^2(\mathbf{H}) = \{0\}$.*

Proof. For any positive integer n , we put

$$\hat{f}_{y,n}(u) = \int_{-n}^n f(x + iy) e^{-2\pi i u(x + iy)} dx = e^{2\pi u y} \int_{-n}^n f_y(x) e^{-2\pi i u x} dx.$$

Since $\hat{f}_y(u) = \text{l.i.m.}_{n \rightarrow \infty} \hat{f}_{y,n}(u) e^{-2\pi u y}$ for $y \notin S_f$, there exists a subset T_y of \mathbb{R} of measure zero such that $\lim_{n \rightarrow \infty} \hat{f}_{y,n}(u)$ exists if $u \notin T_y$. Let y_1 and y_2 be two positive numbers such that $y_1, y_2 \notin S_f$ and $y_1 < y_2$. Take $u \in \mathbb{R}$ so that $u \notin T_{y_1} \cup T_{y_2}$. Since $f \in H_k^2(\mathbf{H})$, we see by Corollary 2.6.3. that $\lim_{|x| \rightarrow \infty} |f(x + iy) e^{-2\pi i u(x + iy)}| = 0$ uniformly on the interval $[y_1, y_2]$. Since $f(z) e^{-2\pi i u z}$ is holomorphic on \mathbf{H} , we have

$$\left\{ \int_{-n+iy_1}^{n+iy_1} + \int_{n+iy_1}^{n+iy_2} + \int_{n+iy_2}^{-n+iy_2} + \int_{-n+iy_2}^{-n+iy_1} \right\} f(z) e^{-2\pi i u z} dz = 0.$$

Therefore $\lim_{n \rightarrow \infty} \hat{f}_{y_1,n}(u) = \lim_{n \rightarrow \infty} \hat{f}_{y_2,n}(u)$. This implies $\lim_{n \rightarrow \infty} \hat{f}_{y,n}(u)$ is independent of y . If we put $\hat{f}(u) = \lim_{n \rightarrow \infty} \hat{f}_{y,n}(u)$ then it satisfies the equation in (1).

Now we see that

$$(6.1.8) \quad \infty > \|f\|_2^2 = \int_0^\infty y^{k-2} dy \int_{-\infty}^\infty |f_y(x)|^2 dx = \int_0^\infty y^{k-2} dy \int_{-\infty}^\infty |\hat{f}(u)|^2 e^{-4\pi uy} du \\ = \int_{-\infty}^\infty |\hat{f}(u)|^2 du \int_0^\infty y^{k-2} e^{-4\pi uy} dy.$$

The integral with respect to y is finite if and only if $k > 1$ and $u > 0$. Then, if $k > 1$, $\hat{f}(u)$ vanishes almost everywhere on \mathbb{R}_- . If $k \leq 1$, $\hat{f}(u)$ should vanish almost everywhere on \mathbb{R} , and therefore $f(z) = 0$. This completes the proof. \square

For $f(z) \in H_k^2(\mathbf{H})$, we call the function $\hat{f}(u)$ on \mathbb{R} the *Fourier transform* of f . Hereafter we assume $k > 1$. We put

$$G_k(u) = \begin{cases} \int_0^\infty y^{k-2} e^{-\pi uy} dy = (\pi u)^{1-k} \Gamma(k-1) & (u > 0), \\ 0 & (u \leq 0). \end{cases}$$

We denote by \hat{H}_k^2 the space of complex valued measurable functions $\phi(u)$ on \mathbb{R} satisfying the following two conditions:

$$(6.1.9) \quad \phi(u) = 0 \text{ almost everywhere on } \mathbb{R}_-;$$

$$(6.1.10) \quad \int_{-\infty}^\infty |\phi(u)|^2 G_k(4u) du < \infty.$$

The space \hat{H}_k^2 is a Hilbert space with the inner product

$$\langle \phi, \varphi \rangle = \int_0^\infty \phi(u) \overline{\varphi(u)} G_k(4u) du \quad (\phi, \varphi \in \hat{H}_k^2).$$

By (6.1.8), we obtain

$$(6.1.11) \quad \|f\|_2^2 = \int_{-\infty}^\infty |\hat{f}(u)|^2 G_k(4u) du = \langle \hat{f}, \hat{f} \rangle \quad (f \in H_k^2(\mathbf{H})).$$

Therefore, if $f \in H_k^2(\mathbf{H})$, then $\hat{f} \in \hat{H}_k^2$. Conversely, let ϕ be an element of \hat{H}_k^2 . For $z \in \mathbf{H}$ and a positive integer n , we put

$$(6.1.12) \quad \hat{\phi}(z) = \int_{-\infty}^\infty \phi(u) e^{2\pi iuz} du, \quad \hat{\phi}_n(z) = \int_{-n}^n \phi(u) e^{2\pi iuz} du.$$

We shall prove that the map " $f(z) \mapsto \hat{f}(u)$ " gives an isomorphism of $H_k^2(\mathbf{H})$ onto \hat{H}_k^2 . We need the following general

Lemma 6.1.5. *Let (X, dx) be a measure space and D a domain in \mathbb{C} . Let $f(z, x)$ be a function on $D \times X$ holomorphic in z for each fixed x . Assume that for any circle C contained in D , $f(z, x)$ is integrable on $C \times X$. Then the function $F(z) = \int_X f(z, x) dx$ is holomorphic on D .*

Proof. Let z be a point of D , and C a circle around z . Then

$$f(z, x) = \frac{1}{2\pi i} \int_C \frac{f(\zeta, x)}{\zeta - z} d\zeta.$$

Therefore

$$F(z) = \int_x f(z, x) dx = \frac{1}{2\pi i} \int_{x \times C} \frac{f(\zeta, x)}{\zeta - z} dx d\zeta = \frac{1}{2\pi i} \int_C \frac{F(\zeta)}{\zeta - z} d\zeta.$$

Thus $F(z)$ is holomorphic on D . □

Theorem 6.1.6. *The correspondence “ $f(z) \mapsto \hat{f}(u)$ ” gives an isomorphism of $H_k^2(\mathbf{H})$ onto \hat{H}_k^2 .*

Proof. We have only to show that the map “ $\phi \mapsto \hat{\phi}$ ” is an isomorphism of \hat{H}_k^2 into $H_k^2(\mathbf{H})$ and it is the inverse of “ $f(z) \mapsto \hat{f}(u)$ ”. Let $\hat{\phi}_n(z)$ be the function given by (6.1.12). By Lemma 6.1.5, it is holomorphic on \mathbf{H} . Let us prove that $\{\hat{\phi}_n(z)\}$ converges to $\hat{\phi}(z)$ uniformly on any compact subset of \mathbf{H} . By definition, we obtain

$$|\hat{\phi}(z) - \hat{\phi}_n(z)| \leq \left(\int_{-\infty}^{-n} + \int_n^{\infty} \right) |\phi(u) e^{2\pi i u z}| du = \int_n^{\infty} |\phi(u) e^{2\pi i u z}| du.$$

By Schwarz’s inequality,

$$\leq \left\{ \int_n^{\infty} |\phi(u)|^2 G_k(4u) du \right\}^{1/2} \cdot \left\{ \int_n^{\infty} |G_k(4u)^{-1/2} e^{2\pi i u z}|^2 du \right\}^{1/2}$$

The first term is independent of z , and converges to 0 if n tends to ∞ . The second term is bounded on any compact subset of \mathbf{H} . In fact,

$$\int_n^{\infty} |G_k(4u)^{-1/2} e^{2\pi i u z}|^2 du \leq \int_0^{\infty} G_k(4u)^{-1} e^{-4\pi u y} du = \frac{k-1}{4\pi y^k},$$

which is bounded on any compact subset of \mathbf{H} . This implies the uniform convergence of $\{\hat{\phi}_n(z)\}$ on any compact subset of \mathbf{H} , and therefore $\hat{\phi}(z)$ is holomorphic. Moreover we obtain

$$\|\hat{\phi}\|_2^2 = \int_{\mathbf{H}} |\hat{\phi}(z)|^2 \text{Im}(z)^k dv(z) = \int_0^{\infty} y^{k-2} dy \int_{-\infty}^{\infty} |\hat{\phi}(x+iy)|^2 dx.$$

Since $\hat{\phi}(x+iy)$ is the Fourier inverse transform of $\phi(u) e^{-2\pi u y}$ considering it as a function of x for each fixed y , the Plancherel theorem implies

$$= \int_0^{\infty} y^{k-2} dy \int_{-\infty}^{\infty} |\phi(u)|^2 e^{-4\pi u y} du = \int_0^{\infty} |\phi(u)|^2 G_k(4u) du = \langle \phi, \phi \rangle.$$

This implies “ $\phi \mapsto \hat{\phi}$ ” is an isomorphism of \hat{H}_k^2 into $H_k^2(\mathbf{H})$. It is easy to see that these two isomorphisms are inverse to each other. □

Corollary 6.1.7. $H_k^2(\mathbf{H}) \neq \{0\}$ if and only if $k > 1$.

Proof. It is obvious that if $k > 1$ then $\hat{H}_k^2 \neq \{0\}$. Then by Theorem 6.1.6, we obtain the result. □

Now we are ready to calculate the constant c_k in Theorem 6.1.2. We denote by $\widehat{K}_k(u, z)$ the Fourier transform of $K_k(z_1, z)$ considering it as a function of z_1 for a fixed z . Then for any $\phi(u) \in \widehat{H}_k^2$, we see that

$$\langle \phi(u), \widehat{K}_k(u, z) \rangle = (\widehat{\phi}(z_1), K_k(z_1, z))_{\mathbf{H}} = \widehat{\phi}(z) = \int_0^\infty \phi(u) e^{2\pi iuz} du.$$

On the other hand, we have

$$\langle \phi(u), \widehat{K}_k(u, z) \rangle = \int_0^\infty \phi(u) \overline{\widehat{K}_k(u, z)} G_k(4u) du.$$

Therefore we obtain

$$\widehat{K}_k(u, z) = G_k(4u)^{-1} e^{-2\pi iuz} \quad ((u, z) \in \mathbb{R} \times \mathbf{H}).$$

Take the inverse transform of $\widehat{K}_k(u, z)$ as a function of u , and we get

$$K_k(z_1, z_2) = \int_0^\infty G_k(4u)^{-1} e^{2\pi iu(z_1 - \bar{z}_2)} du,$$

namely, $c_k(z/2i)^{-k} = \int_0^\infty G_k(4u)^{-1} e^{2\pi iuz} du$. Putting $z = 2i$, we obtain

$$c_k = (k - 1)/4\pi.$$

Thus we obtain the following

Theorem 6.1.8. *If $k > 1$, then the kernel function of $H_k^2(\mathbf{H})$ is given by*

$$K_k(z_1, z_2) = \frac{k - 1}{4\pi} \left(\frac{z_1 - \bar{z}_2}{2i} \right)^{-k} \quad (z_1, z_2 \in \mathbf{H}).$$

§ 6.2. The Projection of $L_k^p(\mathbf{H})$ onto $H_k^p(\mathbf{H})$

Using the kernel function $K_k(z_1, z_2)$ of $H_k^2(\mathbf{H})$, we define the integral operator K on $L_k^p(\mathbf{H})$ by

$$(6.2.1) \quad (Kf)(z) = \int_{\mathbf{H}} K_k(z, z_2) f(z_2) \operatorname{Im}(z_2)^k dv(z_2), \quad f \in L_k^p(\mathbf{H}).$$

The purpose of this section is to prove that the integral operator K is a projection of $L_k^p(\mathbf{K})$ onto its subspace $H_k^p(\mathbf{H})$ for all p ($1 \leq p \leq \infty$). Hereafter we assume $k > 2$. For this purpose, we had better to consider function spaces $L_k^p(\mathbf{K})$ and $H_k^p(\mathbf{K})$ consisting of functions on \mathbf{K} . We denote by $dv_{\mathbf{K}}(w)$ the measure of \mathbf{K} defined in §1.4 given by

$$dv_{\mathbf{K}}(w) = 4(1 - |w|^2)^{-2} dx dy \quad (w = x + iy).$$

For a complex valued measurable function $f(w)$ on \mathbf{K} , we put

$$\|f\|_p = \begin{cases} \left(\int_{\mathbf{K}} |f(w)| (1 - |w|^2)^{k/2} |^p dv_{\mathbf{K}}(w) \right)^{1/p} & (1 \leq p < \infty), \\ \operatorname{ess. sup}_{w \in \mathbf{K}} |f(w)| (1 - |w|^2)^{k/2} & (p = \infty). \end{cases}$$

We denote by $L_k^p(\mathbf{K})$ the space consisting of measurable functions f satisfying $\|f\|_p < \infty$. We also denote by $H_k^p(\mathbf{K})$ the subspace of $L_k^p(\mathbf{K})$ consisting of holomorphic elements. Then $L_k^p(\mathbf{K})$ is a Banach space and $H_k^p(\mathbf{K})$ is a closed subspace of $L_k^p(\mathbf{K})$. Let p and q be conjugate exponents. For functions $f \in L_k^p(\mathbf{K})$ and $g \in L_k^q(\mathbf{K})$, we put

$$(f, g)_{\mathbf{K}} = \int_{\mathbf{K}} f(w) \overline{g(w)} (1 - |w|^2)^k dv_{\mathbf{K}}(w).$$

Theorem 6.2.1. (1) *The Banach space $L_k^p(\mathbf{H})$ (resp. $H_k^p(\mathbf{H})$) is isomorphic to $L_k^p(\mathbf{K})$ (resp. $H_k^p(\mathbf{K})$) by the map “ $f(z) \mapsto \tilde{f}(w) = (1 - w)^{-k} f(\rho^{-1}w)$ ($w \in \mathbf{K}$)”, where*

$$\rho = \begin{bmatrix} 1 & -i \\ 1 & i \end{bmatrix}.$$

(2) *Any holomorphic function bounded on \mathbf{K} belongs to $H_k^p(\mathbf{K})$ for all p ($1 \leq p \leq \infty$).*

(3) *For a fixed $z_2 \in \mathbf{H}$, the function $K_k(z_1, z_2)$ belongs to $H_k^p(\mathbf{H})$ for all p ($1 \leq p \leq \infty$).*

Proof. The first and second assertions can be easily proved. Let $\tilde{f}(w)$ be the function in $H_k^p(\mathbf{K})$ corresponding to the function $K_k(z_1, z_2)$ in $H_k^p(\mathbf{H})$ as a function of z_1 . Then

$$\tilde{f}(w) = (1 - \rho z_1)^{-k} K_k(z_1, z_2) = \frac{k-1}{4\pi} \left(\frac{z_1 + i}{z_1 - \bar{z}_2} \right)^k \quad (z_1 = \rho^{-1}w),$$

and it is bounded. By (2), we obtain (3). □

Theorem 6.2.2. *The integral operator K is a projection of $L_k^p(\mathbf{H})$ onto $H_k^p(\mathbf{H})$ for any p ($1 \leq p \leq \infty$).*

Proof. By Theorem 6.2.1(3), the integral in (6.2.1) is finite. Now we define a function $K_k^*(\alpha)$ on $SL_2(\mathbb{R})$ by

$$(6.2.2) \quad K_k^*(\alpha) = K_k(\alpha i, i) j(\alpha, i)^{-k} \quad (\alpha \in SL_2(\mathbb{R})).$$

Then for $\alpha, \beta \in SL_2(\mathbb{R})$, we see that

$$(6.2.3) \quad K_k(\alpha i, \beta i) j(\alpha, i)^{-k} \overline{j(\beta, i)^{-k}} = K_k^*(\beta^{-1}\alpha)$$

and

$$(6.2.4) \quad K_k^*(\alpha^{-1}) = \overline{K_k^*(\alpha)}.$$

For a measurable function φ on $SL_2(\mathbb{R})$ with respect to the Haar measure $d\alpha$ defined by (1.4.13), we put

$$\|\varphi\|_p = \begin{cases} \left\{ \int_{SL_2(\mathbb{R})} |\varphi(\alpha)|^p d\alpha \right\}^{1/p} & (1 \leq p < \infty), \\ \text{ess. sup}_{\alpha \in SL_2(\mathbb{R})} |\varphi(\alpha)| & (p = \infty). \end{cases}$$

For a function $f(z)$ in $L_k^p(\mathbf{H})$, we put

$$f^*(\alpha) = f(\alpha i) j(\alpha, i)^{-k} \quad (\alpha \in SL_2(\mathbb{R})).$$

Then Theorem 1.4.5 implies $\|f\|_p = \|f^*\|_p$. In particular, we have

$$\|K_k(z, i)\|_p = \|K_k^*(\alpha)\|_p$$

for all p ($1 \leq p \leq \infty$). For a function $f \in L_k^p(\mathbf{H})$, we put

$$g(z) = \int_{\mathbf{H}} K_k(z, z_2) f(z_2) \operatorname{Im}(z_2)^k dv(z_2) \quad (z \in \mathbf{H}).$$

Then we see by (6.2.3),

$$g^*(\alpha) = \int_{SL_2(\mathbb{R})} K_k^*(\beta^{-1}\alpha) f^*(\beta) d\beta.$$

Since $SL_2(\mathbb{R})$ is unimodular, we have by [Weil 5, pp. 54–55], $\|g^*\|_p \leq \|K_k^*\|_1 \cdot \|f^*\|_p$ and therefore

$$\|g\|_p \leq \|K_k(z, i)\|_1 \cdot \|f\|_p.$$

This implies that K is a continuous linear mapping of $L_k^p(\mathbf{H})$ into itself. Next we are going to prove that the image of K is included in $H_k^p(\mathbf{H})$. Let \mathbf{H}_n ($n = 1, 2, \dots$) be compact subsets of \mathbf{H} satisfying $\mathbf{H}_n \subset \mathbf{H}_{n+1}$ and $\bigcup_n \mathbf{H}_n = \mathbf{H}$. We put

$$(K^{(n)}f)(z) = \int_{\mathbf{H}_n} K_k(z, z_2) f(z_2) \operatorname{Im}(z_2)^k dv(z_2) \quad (f \in L_k^p(\mathbf{H})).$$

Then $K^{(n)}f$ is a holomorphic function by Lemma 6.1.5 and

$$\lim_{n \rightarrow \infty} (K^{(n)}f)(z) = (Kf)(z).$$

Let M be a compact subset of \mathbf{H} . Then by Theorem 6.1.8, there exist a point $z_0 \in M$ and a constant C such that

$$|K_k(z_1, z_2)| \leq C |K_k(z_0, z_2)| \quad (z_1 \in M, z_2 \in \mathbf{H}).$$

Hence for $z \in M$,

$$|(Kf)(z) - (K^{(n)}f)(z)| \leq C \int_{\mathbf{H} - \mathbf{H}_n} |K_k(z_0, z_2) f(z_2)| \operatorname{Im}(z_2)^k dv(z_2).$$

Therefore $(K^{(n)}f)(z)$ converges to $(Kf)(z)$ uniformly on any compact subsets of \mathbf{H} and Kf is holomorphic on \mathbf{H} .

In the end, we shall prove that if $f \in H_k^p(\mathbf{H})$, then $Kf = f$. We define a function $\tilde{K}_k(w_1, w_2)$ on $\mathbf{K} \times \mathbf{K}$ by

$$\tilde{K}_k(w_1, w_2) = K_k(\rho^{-1}w_1, \rho^{-1}w_2)(1 - w_1)^{-k} \overline{(1 - w_2)^{-k}} \quad \left(\rho = \begin{bmatrix} 1 & -i \\ 1 & i \end{bmatrix} \right).$$

Then $\tilde{K}_k(w_1, w_2)$ is the kernel function of $H_k^2(\mathbf{K})$ by the isomorphism given in Theorem 6.2.1. For $\tilde{f} \in L_k^p(\mathbf{K})$, we also put

$$(\tilde{K}\tilde{f})(w) = \int_{\mathbf{K}} \tilde{K}_k(w, w_2) \tilde{f}(w_2) (1 - |w_2|^2)^k dv_{\mathbf{K}}(w_2).$$

Put $\tilde{g}_n(w) = w^n$ for $n \geq 0$. Since $\tilde{g}_n \in H_k^2(\mathbf{K})$, we have $\tilde{K}\tilde{g}_n = \tilde{g}_n$. Then for a function \tilde{f} in $H_k^2(\mathbf{K})$, we have

$$(\tilde{K}\tilde{f}, \tilde{g}_n)_{\mathbf{K}} = (\tilde{f}, \tilde{K}\tilde{g}_n)_{\mathbf{K}} = (\tilde{f}, \tilde{g}_n)_{\mathbf{K}}.$$

Therefore $(\tilde{K}\tilde{f} - \tilde{f}, \tilde{g}_n)_{\mathbf{K}} = 0$ for all integer $n (\geq 0)$. Denote the Taylor expansion of $\tilde{K}\tilde{f} - \tilde{f}$ at $w = 0$ by $(\tilde{K}\tilde{f} - \tilde{f})(w) = \sum_{n=0}^{\infty} a_n w^n$. Then

$$(\tilde{K}\tilde{f} - \tilde{f}, \tilde{g}_n)_{\mathbf{K}} = 8\pi a_n \int_0^1 r^{2n+1} (1-r^2)^{k-2} dr.$$

This implies $a_n = 0$ for all $n \geq 0$ and $\tilde{K}\tilde{f} = \tilde{f}$. By the isomorphism in Theorem 6.2.1(1), we obtain $Kf = f$ for all $f \in H_k^2(\mathbf{H})$. □

§ 6.3. Function Spaces Consisting of Automorphic Forms

Let Γ be a Fuchsian group of the first kind, χ a character of Γ of finite order and $k (> 2)$ an integer. We assume $\chi(-1) = (-1)^k$ if Γ contains -1 . For any measurable function $f(z)$ on \mathbf{H} satisfying

$$(6.3.1) \quad (f|_k \gamma)(z) = \chi(\gamma) f(z), \quad \text{for any } \gamma \in \Gamma,$$

we put

$$\|f\|_{\Gamma, p} = \begin{cases} \left\{ \int_{\Gamma \backslash \mathbf{H}} |f(z) \text{Im}(z)^{k/2}|^p dv(z) \right\}^{1/p} & (1 \leq p < \infty), \\ \text{ess. sup}_{z \in \mathbf{H}} |f(z) \text{Im}(z)^{k/2}| & (p = \infty). \end{cases}$$

Since $|f(z) \text{Im}(z)^{k/2}|$ is invariant under the action of Γ , $\|f\|_{\Gamma, p}$ is well defined. For each $p (1 \leq p \leq \infty)$, we denote by $L_k^p(\Gamma, \chi)$ the set of measurable functions on \mathbf{H} satisfying (6.3.1) and $\|f\|_{\Gamma, p} < \infty$, and by $H_k^p(\Gamma, \chi)$ the subspace of $L_k^p(\Gamma, \chi)$ consisting of holomorphic ones. Then $L_k^p(\Gamma, \chi)$ is a Banach space and $H_k^p(\Gamma, \chi)$ is a closed subspace. The space $L_k^2(\Gamma, \chi)$ is a Hilbert space with the inner product

$$(f, g)_{\Gamma} = \int_{\Gamma \backslash \mathbf{H}} f(z) \overline{g(z)} \text{Im}(z)^k dv(z) \quad (f, g \in L_k^2(\Gamma, \chi)).$$

Since the volume of $\Gamma \backslash \mathbf{H}$ is finite, $L_k^{\infty}(\Gamma, \chi) \subset L_k^p(\Gamma, \chi)$ and $H_k^{\infty}(\Gamma, \chi) \subset H_k^p(\Gamma, \chi)$ for all $p (1 \leq p < \infty)$. Moreover by Theorem 2.1.5, $H_k^{\infty}(\Gamma, \chi) = \mathcal{S}_k(\Gamma, \chi)$ and the restriction of the inner product of $L_k^2(\Gamma, \chi)$ to $H_k^{\infty}(\Gamma, \chi)$ coincides with the Petersson inner product up to a constant multiple.

Theorem 6.3.1. $H_k^2(\Gamma, \chi) = H_k^{\infty}(\Gamma, \chi)$.

Proof. The assertion is obvious when $\Gamma \backslash \mathbf{H}$ is compact. Assume that Γ has a cusp x_0 . Let f be an element in $H_k^2(\Gamma, \chi)$. To prove $f \in H_k^{\infty}(\Gamma, \chi)$, we may assume χ is

trivial by taking a subgroup of Γ of finite index on which χ is trivial. Take an element σ of $SL_2(\mathbb{R})$ such that $\sigma\infty = x_0$, and put

$$\sigma^{-1}\Gamma_{x_0}\sigma \cdot \{\pm 1\} = \left\{ \pm \begin{bmatrix} 1 & h \\ 0 & 1 \end{bmatrix}^m \mid m \in \mathbb{Z} \right\} \quad (h > 0).$$

Denote the Fourier expansion of $f|_k\sigma$ by

$$(f|_k\sigma)(z) = \sum_{n=-\infty}^{\infty} a_n e^{\pi i n z/h}.$$

Let $l > 0$. Then we see by Corollary 1.7.5,

$$\begin{aligned} \infty &> \int_{\Gamma \backslash \mathbf{H}} |f(z)|^2 \operatorname{Im}(z)^k dv(z) \\ &\geq \frac{1}{2} \int \int_{\substack{0 \leq \operatorname{Re}(z) \leq 2h \\ l \leq \operatorname{Im}(z) < \infty}} |f(\sigma z) j(\sigma, z)^{-k}|^2 \operatorname{Im}(z)^k dv(z) \\ &= \frac{1}{2} \int_l^\infty \int_0^{2h} \sum_{m, n=-\infty}^\infty a_m \bar{a}_n e^{-\pi y(m+n)/h} e^{\pi i x(m-n)/h} y^{k-2} dx dy \\ &\geq h |a_n|^2 \int_l^\infty e^{-2\pi y n/h} y^{k-2} dy, \end{aligned}$$

for any integer n . Since $k > 2$, we have $a_n = 0$ if $n \leq 0$. Thus we proved $f \in \mathcal{S}_k(\Gamma, \chi) = H_k^\infty(\Gamma, \chi)$. □

For any element $f(z)$ in $L_k^1(\mathbf{H})$, we put

$$(6.3.2) \quad f^\Gamma(z) = |Z(\Gamma)|^{-1} \sum_{\gamma \in \Gamma} \overline{\chi(\gamma)} f(\gamma z) j(\gamma, z)^{-k} \quad (z \in \mathbf{H}).$$

We also put

$$(6.3.3) \quad K_k^\Gamma(z_1, z_2) = |Z(\Gamma)|^{-1} \sum_{\gamma \in \Gamma} \overline{\chi(\gamma)} K_k(\gamma z_1, z_2) j(\gamma, z_1)^{-k} \quad (z_1, z_2 \in \mathbf{H}).$$

Theorem 6.3.2. (1) *The right hand side of (6.3.2) is absolutely convergent almost everywhere on \mathbf{H} and $f^\Gamma(z) \in L_k^1(\Gamma, \chi)$.*

(2) *If $f(z) \in H_k^1(\mathbf{H})$, then $f^\Gamma(z) \in H_k^1(\Gamma, \chi)$. In particular, $K_k^\Gamma(z, z_2)$ belongs to $H_k^1(\Gamma, \chi)$ as a function of z for each fixed z_2 .*

(3) *The right-hand side of (6.3.3) is uniformly convergent on any compact subset of $\mathbf{H} \times \mathbf{H}$.*

Proof. We see

$$\begin{aligned} &|Z(\Gamma)| \int_{\Gamma \backslash \mathbf{H}} |f^\Gamma(z)| \operatorname{Im}(z)^{k/2} dv(z) \\ &\leq \int_{\Gamma \backslash \mathbf{H}} \sum_{\gamma \in \Gamma} |f(\gamma z) j(\gamma, z)^{-k}| \operatorname{Im}(z)^{k/2} dv(z) \\ &= |Z(\Gamma)| \int_{\mathbf{H}} |f(z)| \operatorname{Im}(z)^{k/2} dv(z) < \infty. \end{aligned}$$

Therefore the right-hand side of (6.3.2) is absolutely convergent almost everywhere on \mathbf{H} . Since it is obvious that $f^\Gamma(z)$ satisfies (6.3.1), f^Γ belongs to $L_k^1(\Gamma, \chi)$. The second assertion is derived from this and Theorem 2.6.6(1). Take $K_k(z_1, z_2)$ as $f(z)$ in (1), and we see by (6.1.6)

$$\begin{aligned} & \int_{\Gamma \setminus \mathbf{H}} \sum_{\gamma \in \Gamma} |K_k(\gamma z_1, z_2)| |j(\gamma, z_1)|^{-k} \text{Im}(z_1)^{k/2} dv(z_1) \\ &= |Z(\Gamma)| \int_{\mathbf{H}} |K_k(z_1, z_2)| \text{Im}(z_1)^{k/2} dv(z_1) \\ &= |Z(\Gamma)| \text{Im}(z_2)^{-k/2} \int_{\mathbf{H}} |K_k(z_1, i)| \text{Im}(z_1)^{k/2} dv(z_1). \end{aligned}$$

Therefore we obtain (3) by Corollary 2.6.4. □

Theorem 6.3.3. *The function $K_k^\Gamma(z_1, z_2)$ is the kernel function of $H_k^2(\Gamma, \chi)$.*

Proof. We note that $H_k^2(\Gamma, \chi) = H_k^\infty(\Gamma, \chi)$. Let f be a function in $H_k^\infty(\Gamma, \chi)$. Take a fundamental domain F of Γ . Since $f(z)\text{Im}(z)^{k/2}$ is bounded, we see by (6.1.6),

$$\begin{aligned} & \sum_{\gamma \in \Gamma} \int_{\Gamma \setminus \mathbf{H}} |K_k(\gamma z_1, z_2)| j(\gamma, z_1)^{-k} f(z_2) |\text{Im}(z_2)^k| dv(z_2) \\ & \leq C \sum_{\gamma \in \Gamma} \int_F |K_k(\gamma^{-1} z_2, z_1)| j(\gamma^{-1}, z_2)^{-k} |\text{Im}(z_2)^{k/2}| dv(z_2) \\ & = C |Z(\Gamma)| \int_{\mathbf{H}} |K_k(z_2, z_1)| \text{Im}(z_2)^{k/2} dv(z_2) \end{aligned}$$

with a constant C . Therefore we obtain

$$\begin{aligned} & \int_{\Gamma \setminus \mathbf{H}} K_k^\Gamma(z_1, z_2) f(z_2) \text{Im}(z_2)^k dv(z_2) \\ &= |Z(\Gamma)|^{-1} \sum_{\gamma \in \Gamma} \int_{\gamma^{-1} F} K_k(z_1, z_2) f(z_2) \text{Im}(z_2)^k dv(z_2) \\ &= \int_{\mathbf{H}} K_k(z_1, z_2) f(z_2) \text{Im}(z_2)^k dv(z_2) \\ &= f(z_1), \end{aligned}$$

because $f \in H_k^\infty(\Gamma, \chi) \subset H_k^\infty(\mathbf{H})$. To prove that $K_k^\Gamma(z_1, z_2)$ belongs to $H_k^\infty(\Gamma, \chi)$ as a function of z_1 , we have only to show that $K_k^\Gamma(z_1, z_2)$ belongs to $H_k^\infty(\mathbf{H})$ as a function of z_1 . It is well known that $L_k^\infty(\mathbf{H})$ is the dual space of $L_k^1(\mathbf{H})$. A sequence $\{f_n\}$ in $L_k^\infty(\mathbf{H})$ is called weakly* convergent if $\{(f_n, g)_\mathbf{H}\}$ is convergent for any $g \in L_k^1(\mathbf{H})$. It can be proved that if a sequence $\{f_n\}$ is weakly* convergent, then there exists f in $L_k^\infty(\mathbf{H})$ such that the sequence $\{(f_n, g)_\mathbf{H}\}$ converges to $(f, g)_\mathbf{H}$ for any g ([Yoshida, V, Theorem 9]) and the function f is uniquely determined as a measurable function on \mathbf{H} . Therefore we have only to prove that $\sum_{\gamma \in \Gamma} \overline{\chi(\gamma)} K_k(\gamma z_1, z_2) j(\gamma, z_1)^{-k}$ is weakly* convergent for a fixed z_2 , namely that for a fixed $z_2 \in \mathbf{H}$ and $g \in L_k^1(\mathbf{H})$,

$\sum_{\gamma \in \Gamma} \int_{\mathbf{H}} \overline{\chi(\gamma)} K_k(\gamma z_1, z_2) j(\gamma, z_1)^{-k} \overline{g(z_1)} \operatorname{Im}(z_1)^k dv(z_1)$ is convergent. Since

$$\begin{aligned} & \int_{\mathbf{H}} K_k(\gamma z_1, z_2) j(\gamma, z_1)^{-k} \overline{g(z_1)} \operatorname{Im}(z_1)^k dv(z_1) \\ &= \overline{\int_{\mathbf{H}} K_k(\gamma^{-1} z_2, z_1) j(\gamma^{-1}, z_2)^{-k} g(z_1) \operatorname{Im}(z_1)^k dv(z_1)} \\ &= \overline{(Kg)(\gamma^{-1} z_2) j(\gamma^{-1}, z_2)^{-k}}, \end{aligned}$$

and $\sum_{\gamma \in \Gamma} \overline{\chi(\gamma^{-1})} (Kg)(\gamma^{-1} z_2) j(\gamma^{-1}, z_2)^{-k}$ is absolutely convergent by Theorem 6.3.2, we obtain the result. \square

§6.4. Traces of Hecke Operators (Calculation of Integrals)

Before calculating the traces of Hecke operators, we express the dimension of the space of automorphic forms in terms of integral to illustrate our calculation.

Theorem 6.4.1. $\dim \mathcal{S}_k(\Gamma, \chi) = \int_{\Gamma \backslash \mathbf{H}} K_k^\Gamma(z, z) \operatorname{Im}(z)^k dv(z).$

Proof. Let $\{f_j(z)\}_{j=1}^n$ be an orthonormal basis of $\mathcal{S}_k(\Gamma, \chi)$ with respect to the inner product $(\cdot, \cdot)_\Gamma$. Then we have

$$K_k^\Gamma(z_1, z_2) = \sum_{j=1}^n f_j(z_1) \overline{f_j(z_2)}.$$

Therefore

$$\dim \mathcal{S}_k(\Gamma, \chi) = \sum_{j=1}^n (f_j, f_j)_\Gamma = \int_{\Gamma \backslash \mathbf{H}} K_k^\Gamma(z, z) \operatorname{Im}(z)^k dv(z). \quad \square$$

Now let Δ be a subsemigroup of $GL_2^+(\mathbb{R})$ contained in $\tilde{\Gamma}$ (see §2.8). We assume χ can be extended to a homomorphism of Δ to \mathbb{C} satisfying (2.8.1). As we showed in §2.7 and §2.8, we can let the Hecke algebra $\mathcal{R}(\Gamma, \Delta)$ act on $\mathcal{S}_k(\Gamma, \chi)$. Let T be a subset of Δ . We assume T is a union of finitely many double Γ -cosets and write $T = \coprod_{i=1}^m \Gamma \beta_i \Gamma$. We identify T with the element $\sum_{i=1}^m \Gamma \beta_i \Gamma$ of $\mathcal{R}(\Gamma, \Delta)$ and let it operate on $\mathcal{S}_k(\Gamma, \chi)$. More precisely, the operation of T on $f \in \mathcal{S}_k(\Gamma, \chi)$ is given by

$$(6.4.1) \quad f|T = \sum_{j=1}^d \det(\alpha_j)^{k/2-1} \overline{\chi(\alpha_j)} f|_k \alpha_j \quad \left(T = \prod_{j=1}^d \Gamma \alpha_j \right).$$

For example, take $\Gamma = \Gamma_0(N)$, $\Delta = \Delta_0(N)$ and $T = \{\alpha \in \Delta_0(N) \mid \det(\alpha) = n\}$. Then T corresponds to $T(n)$ of $\mathcal{R}(N) = \mathcal{R}(\Gamma_0(N), \Delta_0(N))$. Our purpose in this section is to calculate the trace of the operator T on $\mathcal{S}_k(\Gamma, \chi)$.

For an element α in T , we put

$$(6.4.2) \quad \kappa(z; \alpha) = \det(\alpha)^{k-1} \overline{\chi(\alpha)} K_k(\alpha z, z) j(\alpha, z)^{-k} \operatorname{Im}(z)^k \quad (z \in \mathbf{H}).$$

Theorem 6.4.2. Put $\text{tr}(T) = \text{trace}(T|_{\mathcal{S}_k(\Gamma, \chi)})$. Then

$$\text{tr}(T) = |Z(\Gamma)|^{-1} \int_{\Gamma \backslash \mathbf{H}} \sum_{\alpha \in T} \kappa(z; \alpha) dv(z).$$

Proof. Let $\{f_i(z)\}_{i=1}^n$ be an orthonormal basis of $\mathcal{S}_k(\Gamma, \chi)$ and $T = \coprod_{j=1}^d \Gamma \alpha_j$. Then we see that

$$\begin{aligned} \text{tr}(T) &= \sum_{i=1}^n (f_i | T, f_i)_\Gamma \\ &= \sum_{i=1}^n \int_{\Gamma \backslash \mathbf{H}} \sum_{j=1}^d \det(\alpha_j)^{k-1} \overline{\chi(\alpha_j)} f_i(\alpha_j z) j(\alpha_j, z)^{-k} \overline{f_i(z)} \text{Im}(z)^k dv(z) \\ &= \int_{\Gamma \backslash \mathbf{H}} \sum_{j=1}^d \det(\alpha_j)^{k-1} \overline{\chi(\alpha_j)} K_k^\Gamma(\alpha_j z, z) j(\alpha_j, z)^{-k} \text{Im}(z)^k dv(z) \\ &= |Z(\Gamma)|^{-1} \int_{\Gamma \backslash \mathbf{H}} \sum_{\alpha \in T} \det(\alpha)^{k-1} \overline{\chi(\alpha)} K_k(\alpha z, z) j(\alpha, z)^{-k} \text{Im}(z)^k dv(z). \quad \square \end{aligned}$$

Now we are going to calculate the integral in the Theorem 6.4.2. The integrand is uniformly convergent on any compact subset of \mathbf{H} by Theorem 6.3.2(3). Therefore we can exchange the order of summation and integration if $\Gamma \backslash \mathbf{H}$ is compact. In the case where Γ has cusps, we divide the integral into an integral on a compact subset and integrals on neighborhoods of cusps. For a cusp x of Γ , we put $T_x = \{\alpha \in T | \alpha x = x\}$. For a neighborhood U_x of x in \mathbf{H} stable under Γ_x , we have

$$\begin{aligned} (6.4.3) \quad & \int_{\Gamma_x \backslash U_x} \sum_{\alpha \in T} \kappa(z; \alpha) dv(z) \\ &= \int_{\Gamma_x \backslash U_x} \sum_{\alpha \in T - T_x} \kappa(z; \alpha) dv(z) + \int_{\Gamma_x \backslash U_x} \sum_{\alpha \in T_x} \kappa(\mathfrak{s}; \alpha) dv(z). \end{aligned}$$

Let us consider the first term of the right-hand side. For $\alpha = \begin{bmatrix} a & b \\ c & d \end{bmatrix}$, we write c and d as c_α and d_α , respectively. We note that if $\beta \in \Gamma_\infty \alpha \Gamma_\infty$, then $|c_\alpha| = |c_\beta|$.

Lemma 6.4.3. Assume ∞ is a cusp of Γ . Then for any $l(>0)$,

$$\sum_{\alpha \in \Gamma_\infty \backslash (T - T_\infty) / \Gamma_\infty} \det(\alpha)^l |c_\alpha|^{-k}$$

is convergent.

Proof. Let $\{\alpha\}$ be a set of complete representatives of $\Gamma_\infty \backslash (T - T_\infty) / \Gamma_\infty$ and $T = \coprod_{j=1}^d \Gamma \alpha_j$. Then we see

$$\begin{aligned} & \sum_{\{\alpha\}} \det(\alpha)^l |j(\alpha, z)|^{-k} \leq \sum_{\alpha \in \Gamma_\infty \backslash T} \det(\alpha)^l |j(\alpha, z)|^{-k} \\ &= \sum_{j=1}^d \det(\alpha_j)^l |j(\alpha_j, z)|^{-k} \sum_{\gamma \in \Gamma_\infty \backslash \Gamma} |j(\gamma, \alpha_j z)|^{-k}. \end{aligned}$$

For a compact subset M of \mathbf{H} , we put $m = \# \{\gamma \in \Gamma | \gamma M \cap M \neq \emptyset\}$. Further, there exists, by Lemma 1.7.6, a positive number u satisfying that $\gamma M \subset \{z \in \mathbf{H} | \text{Im}(z) < u\}$

for any $\gamma \in \Gamma$. Since

$$\int_M \sum_{\gamma \in \Gamma_\infty \backslash \Gamma} |j(\gamma, z)|^{-k} \text{Im}(z)^{k/2} dv(z) \leq m \int_0^u \int_0^h y^{k/2-2} dx dy < \infty,$$

$\sum_{\gamma \in \Gamma_\infty \backslash \Gamma} |j(\gamma, z)|^{-k}$ is convergent almost everywhere on M . Since M is arbitrary, the set of points z at which $\sum_{\{\alpha\}} \det(\alpha)^l |j(\alpha, z)|^{-k}$ is convergent is dense in \mathbf{H} . Let h be a positive number such that $\Gamma_\infty \cdot \{\pm 1\} = \left\{ \pm \begin{bmatrix} 1 & mh \\ 0 & 1 \end{bmatrix} \mid m \in \mathbb{Z} \right\}$, and take the set $\{\alpha\}$ so that $|d_\alpha| < |hc_\alpha|$. Take a point z so that $\sum_{\{\alpha\}} \det(\alpha)^l |j(\alpha, z)|^{-k}$ is convergent and $|z| \geq h$, then we obtain

$$\sum_{\{\alpha\}} \det(\alpha)^l |c_\alpha|^{-k} < |2z|^k \sum_{\{\alpha\}} \det(\alpha)^l |j(\alpha, z)|^{-k} < \infty. \quad \square$$

Lemma 6.4.4. *For any two real numbers h ($h > 0$) and l ($l > 1/2$), there exists a positive number C such that*

$$\sum_{n=-\infty}^{\infty} \{(a + nh)^2 + b^2\}^{-l} < C(|b|^{-2l+1} + |b|^{-2l})$$

for any real numbers a and b .

Proof. We see easily that

$$\sum_{n=-\infty}^{\infty} \{(a + nh)^2 + b^2\}^{-l} < \frac{1}{h} \int_{-\infty}^{\infty} (t^2 + b^2)^{-l} dt + |b|^{-2l}.$$

Dividing the integral into the sum of $\int_0^{|b|}$ and $\int_{|b|}^{\infty}$, we obtain the estimate. \square

Theorem 6.4.5. *Let x and U_x be the same as above. Then*

$$\int_{\Gamma_x \backslash U_x} \sum_{\alpha \in T - T_x} \kappa(z; \alpha) dv(z) = \sum_{\alpha \in T - T_x} \int_{\Gamma_x \backslash U_x} \kappa(z; \alpha) dv(z).$$

Proof. Put

$$z) = S(z; \Gamma, x) = \sum_{\alpha \in T - T_x} |\kappa(z; \alpha)|.$$

We have only to prove that $S(z)$ is convergent on U_x and integrable on $\Gamma_x \backslash U_x$. Since $S(z; \Gamma, x) = S(\sigma z; \sigma \Gamma \sigma^{-1}, \infty)$ for $\sigma \in SL_2(\mathbb{R})$ satisfying $\sigma x = \infty$, we may assume $x = \infty$. Let h be a positive number such that $\Gamma_\infty \cdot \{\pm 1\} = \left\{ \pm \begin{bmatrix} 1 & mh \\ 0 & 1 \end{bmatrix} \mid m \in \mathbb{Z} \right\}$. Then

$$S(z) = |Z(\Gamma)| \sum_{\alpha \in \Gamma_\infty \backslash (T - T_\infty)} \det(\alpha)^{k-1} |j(\alpha, z)|^{-k} \text{Im}(z)^k \times \sum_{n=-\infty}^{\infty} |K_k(\alpha z + nh, z)|.$$

Now by Lemma 6.4.4,

$$\begin{aligned} \sum_{n=-\infty}^{\infty} |K_k(\alpha z + nh, z)| &= \frac{k-1}{4\pi} 2^k \sum_{n=-\infty}^{\infty} \{(\operatorname{Re}(\alpha z - \bar{z}) + nh)^2 + \operatorname{Im}(\alpha z - \bar{z})^2\}^{-k/2} \\ &\leq C_1 \{ \operatorname{Im}(\alpha z - \bar{z})^{-k+1} + \operatorname{Im}(\alpha z - \bar{z})^{-k} \} \end{aligned}$$

with a constant C_1 . Since $\operatorname{Im}(\alpha z - \bar{z}) = \operatorname{Im}(\alpha z) + \operatorname{Im}(z) \geq \operatorname{Im}(z)$, we see by Lemma 6.4.4,

$$\begin{aligned} (6.4.4) \quad S(z) &\leq C_1 (\operatorname{Im}(z) + 1) \sum_{\alpha \in \Gamma_\infty \setminus (T - T_\infty)} \det(\alpha)^{k-1} |j(\alpha, z)|^{-k} \\ &\leq C_1 (\operatorname{Im}(z) + 1) \sum_{\alpha \in \Gamma_\infty \setminus (T - T_\infty) / \Gamma_\infty} \det(\alpha)^{k-1} \sum_{n=-\infty}^{\infty} |c_\alpha(z + nh) + d_\alpha|^{-k} \\ &\leq C_2 \operatorname{Im}(z)^{-k} (\operatorname{Im}(z) + 1)^2 \sum_{\alpha \in \Gamma_\infty \setminus (T - T_\infty) / \Gamma_\infty} \det(\alpha)^{k-1} |c_\alpha|^{-k} \end{aligned}$$

with a constant C_2 . By Lemma 6.4.3, $S(z)$ is convergent and bounded on U_∞ . Since $\Gamma_\infty \setminus U_\infty$ has finite volume, $S(z)$ is integrable on $\Gamma_\infty \setminus U_\infty$ and we can exchange the order of integration on the left-hand side of the equality in the theorem. \square

Next let us investigate the second term on the right-hand side of (6.4.3).

Lemma 6.4.6. *If x is a cusp of Γ , then $|\Gamma_x \setminus T_x| < \infty$.*

Proof. If α and β are elements of T_x such that $\alpha\beta^{-1} \in \Gamma$, then $\alpha\beta^{-1}x = x$, and therefore $\alpha\beta^{-1} \in \Gamma_x$. This implies $|\Gamma_x \setminus T_x| \leq |\Gamma \setminus T| < \infty$. \square

Theorem 6.4.7. *Let x be a cusp of Γ , and σ an element of $SL_2(\mathbb{R})$ such that $\sigma x = \infty$. Then*

$$\begin{aligned} &\int_{\Gamma_x \setminus U_x} \sum_{\alpha \in T_x} \kappa(z; \alpha) dv(z) \\ &= \lim_{s \rightarrow +0} \sum_{\alpha \in T_x} \int_{\Gamma_x \setminus U_x} \kappa(z; \alpha) \operatorname{Im}(z)^{-s} |j(\sigma, z)|^{2s} dv(z). \end{aligned}$$

Proof. We may assume $x = \infty$ and $\sigma = 1$ as usual. Since $\operatorname{Im}(z)^{-s}$ is convergent to 1 monotonously increasingly when $s (> 0)$ tends to 0, we see

$$\int_{\Gamma_\infty \setminus U_\infty} \sum_{\alpha \in T_\infty} \kappa(z; \alpha) dv(z) = \lim_{s \rightarrow +0} \int_{\Gamma_\infty \setminus U_\infty} \sum_{\alpha \in T_\infty} \kappa(z; \alpha) \operatorname{Im}(z)^{-s} dv(z).$$

We shall show that the order of integration and summation on the right-hand side is exchangable. Put

$$S(z, s) = \sum_{\alpha \in T_\infty} |\kappa(z; \alpha)| \operatorname{Im}(z)^{-s} \quad (s > 0).$$

We have only to see that $S(z, s)$ is integrable on $\Gamma_\infty \setminus U_\infty$. Similarly to (6.4.4), we have

$$S(z, s) \leq C_1 (\operatorname{Im}(z)^{1-s} + \operatorname{Im}(z)^{-s}) \sum_{\alpha \in \Gamma_\infty \setminus T_\infty} \det(\alpha)^{k-1} |j(\alpha, z)|^{-k}$$

with a constant C_1 . Since $(\text{Im}(z)^{1-s} + \text{Im}(z)^{-s})|j(\alpha, z)|^{-k}$ is integrable on $\Gamma_\infty \setminus U_\infty$ and $\Gamma_\infty \setminus T_\infty$ is a finite set, $S(z, s)$ is also integrable on $\Gamma_\infty \setminus U_\infty$. \square

Let P_Γ be the set of all cusps of Γ . Take neighborhoods U_x of cusps x so that they satisfy

$$(6.4.5) \quad U_{\gamma x} = \gamma U_x \ (\gamma \in \Gamma) \quad \text{and} \quad U_x \cap U_{x'} = \emptyset \quad \text{if } x \neq x'.$$

Also take elements $\sigma_x \in SL_2(\mathbb{R})$ so that $\sigma_x x = \infty$ and $\text{Im}(\sigma_{\gamma x} \gamma z) = \text{Im}(\sigma_x z)$ ($\gamma \in \Gamma$). We put

$$Z(T) = T \cap \mathbb{R}^\times, \quad T^2 = \bigcup_{x \in P_\Gamma} (T_x - Z(T)) \quad \text{and} \quad T^1 = T - T^2.$$

For $\alpha \in T^2$, we put

$$(6.4.6) \quad \kappa(z; \alpha, s) = \begin{cases} \kappa(z; \alpha) & \left(z \notin \bigcup_{\alpha x = x} U_x \right), \\ \kappa(z; \alpha) \text{Im}(z)^{-s} |j(\sigma_x, z)|^{2s} & \left(z \in \bigcup_{\alpha x = x} U_x \right). \end{cases}$$

Then by Theorems 6.4.2, 6.4.5 and 6.4.7, we obtain

$$(6.4.7) \quad |Z(\Gamma)| \text{tr}(T) = \sum_{\alpha \in T^1} \int_{\Gamma \setminus \mathbf{H}} \kappa(z; \alpha) dv(z) \\ + \lim_{s \rightarrow +0} \sum_{\alpha \in T^2} \int_{\Gamma \setminus \mathbf{H}} \kappa(z; \alpha, s) dv(z).$$

Before calculating the right-hand side, we introduce notations on conjugacy classes. Let G be a group, and H a subgroup of G . We say two elements g_1 and g_2 of G are *H-conjugate* and write $g_1 \sim_H g_2$, if there exists an element h in H such that $g_2 = h^{-1} g_1 h$. For an element g of G , we put

$$C_H(g) = C_{H,G}(g) = \{g' \in G \mid g' \sim_H g\}.$$

The H -conjugacy gives an equivalence relation in any subset of G . For a subset M of G stable under inner automorphisms of G by elements of H , we denote by $M//H$ the set of all H -conjugacy classes in M , or $M//H = M/\sim_H$.

Let us return to the present situation. Since $\gamma T_x \gamma^{-1} = T_{\gamma x}$ for any $\gamma \in \Gamma$, both T^1 and T^2 are unions of Γ -conjugacy classes. For any $\alpha \in T$, we put

$$\Gamma(\alpha) = \{\gamma \in \Gamma \mid \alpha\gamma = \gamma\alpha\}.$$

Then we can rewrite (6.4.7) and obtain

Theorem 6.4.8.

$$|Z(\Gamma)| \text{tr}(T) = \sum_{\alpha \in T^1//\Gamma} \int_{\Gamma(\alpha) \setminus \mathbf{H}} \kappa(z; \alpha) dv(z) \\ + \lim_{s \rightarrow +0} \sum_{\alpha \in T^2//\Gamma} \int_{\Gamma(\alpha) \setminus \mathbf{H}} \kappa(z; \alpha, s) dv(z).$$

Proof. Let F be a fundamental domain of Γ . Then by the choice of σ_x , we see for $\gamma \in \Gamma$,

$$\int_F \kappa(z; \gamma^{-1} \alpha \gamma) dv(z) = \int_{\gamma F} \kappa(z; \alpha) dv(z).$$

Therefore for each fixed $\alpha \in T^1$, we obtain

$$\begin{aligned} \sum_{\beta \in T^1, \beta \neq \alpha} \int_F \kappa(z; \beta) dv(z) &= \sum_{\gamma \in \Gamma(\alpha) \setminus \Gamma} \int_F \kappa(z; \gamma^{-1} \alpha \gamma) dv(z) \\ &= \int_{\Gamma(\alpha) \setminus \mathbf{H}} \kappa(z; \alpha) dv(z). \end{aligned}$$

A similar argument is also applicable to the terms for $\alpha \in T^2$. □

The next step is the calculation of the integrals in Theorem 6.4.8 depending on the type of α .

1°. The case where $\alpha \in Z(\Gamma)$. Put $\alpha = \begin{bmatrix} a & 0 \\ 0 & a \end{bmatrix}$. Since $\Gamma(\alpha) = \Gamma$, we see

$$\begin{aligned} \int_{\Gamma(\alpha) \setminus \mathbf{H}} \kappa(z; \alpha) dv(z) &= \frac{k-1}{4\pi} \det(\alpha)^{k-1} \overline{\chi(\alpha)} a^{-k} \int_{\Gamma \setminus \mathbf{H}} dv(z) \\ &= \frac{k-1}{4\pi} \overline{\chi(\alpha)} \operatorname{sgn}(a)^k \det(\alpha)^{k/2-1} v(\Gamma \setminus \mathbf{H}). \end{aligned}$$

2°. The case where α is elliptic. Let $z_0 \in \mathbf{H}$ be the fixed point of α , and put $\rho = \begin{bmatrix} 1 & -z_0 \\ 1 & -\bar{z}_0 \end{bmatrix}$, which maps \mathbf{H} onto \mathbf{K} . We see $\rho \alpha \rho^{-1} = \begin{bmatrix} \eta & 0 \\ 0 & \zeta \end{bmatrix}$ ($\eta, \zeta \in \mathbb{C}$) and $j(\alpha, z) = \zeta(z - \bar{z}_0)/(az - \bar{z}_0)$. Put $w = \rho z$, $w' = \rho \bar{z}$ and write $w = re^{i\theta}$, $w' = r^{-1}e^{i\theta}$. Since the anharmonic ratio is invariant under the action of linear fractional transformations, we have

$$\frac{z - \bar{z}}{\alpha z - \bar{z}} \frac{\alpha z - \bar{z}_0}{z - \bar{z}_0} = \frac{w - w'}{\eta \zeta^{-1} w - w'},$$

and therefore

$$\kappa(z; \alpha) = \frac{k-1}{4\pi} \det(\alpha)^{k-1} \overline{\chi(\alpha)} \zeta^{-k} \left(\frac{1-r^2}{1-\eta \zeta^{-1} r^2} \right)^k.$$

Since $dv_{\mathbf{K}}(w) = 4r(1-r^2)^{-2} dr d\theta$, we obtain

$$\begin{aligned} &\int_{\Gamma(\alpha) \setminus \mathbf{H}} \kappa(z; \alpha) dv(z) \\ &= \frac{k-1}{4\pi} \det(\alpha)^{k-1} \overline{\chi(\alpha)} \zeta^{-k} \int_{\rho \Gamma(\alpha) \rho^{-1} \setminus \mathbf{K}} 4r(1-r^2)^{k-2} (1-\eta \zeta^{-1} r^2)^{-k} dr d\theta \\ &= \frac{(k-1) \det(\alpha)^{k-1} \overline{\chi(\alpha)} \zeta^{-k}}{[\Gamma(\alpha) : Z(\Gamma)]} \int_0^1 (1-r)^{k-2} (1-\eta \zeta^{-1} r)^{-k} dr \\ &= \frac{-\overline{\chi(\alpha)}}{[\Gamma(\alpha) : Z(\Gamma)]} \frac{\eta^{k-1}}{\eta - \zeta}. \end{aligned}$$

3°. The case where α is hyperbolic and all fixed points of α are not cusps of Γ . Let $x_1, x_2 \in \mathbb{R} \cup \{\infty\}$ be two distinct fixed points of α . Take $\sigma \in SL_2(\mathbb{R})$ so that

$\sigma x_1 = \infty$ and $\sigma x_2 = 0$. Then

$$\sigma \alpha \sigma^{-1} = \begin{bmatrix} \eta & 0 \\ 0 & \zeta \end{bmatrix} \quad (\eta, \zeta \in \mathbb{R}, \eta \neq \zeta).$$

We see $\Gamma(\alpha) = \Gamma_{x_1, x_2}$ by Lemma 1.3.3(3). If $\Gamma(\alpha) \neq Z(\Gamma)$, then by Theorem 1.5.4(3),

$$\sigma \Gamma(\alpha) \sigma^{-1} \cdot \{\pm 1\} = \sigma \Gamma_{x_1, x_2} \sigma^{-1} \cdot \{\pm 1\} = \left\{ \pm \begin{bmatrix} u & 0 \\ 0 & u^{-1} \end{bmatrix}^m \mid m \in \mathbb{Z} \right\}$$

with $u \in \mathbb{R}^\times$ such that $|u| > 1$. Put $w = \sigma z = r e^{i\theta}$. Similarly to 2°, we obtain

$$\int_{\Gamma(\alpha) \backslash \mathbf{H}} \kappa(z; \alpha) dv(z) = \begin{cases} \frac{k-1}{4\pi} \det(\alpha)^{k-1} \overline{\chi(\alpha)} \zeta^{-k} \int_0^\infty \frac{dr}{r} \int_0^\pi \left(\frac{e^{i\theta} - e^{-i\theta}}{\eta \zeta^{-1} e^{i\theta} - e^{-i\theta}} \right)^k \frac{d\theta}{\sin^2 \theta} & (\Gamma(\alpha) = Z(\Gamma)), \\ \frac{k-1}{4\pi} \det(\alpha)^{k-1} \overline{\chi(\alpha)} \zeta^{-k} \int_1^{u^2} \frac{dr}{r} \int_0^\pi \left(\frac{e^{i\theta} - e^{-i\theta}}{\eta \zeta^{-1} e^{i\theta} - e^{-i\theta}} \right)^k \frac{d\theta}{\sin^2 \theta} & (\Gamma(\alpha) \neq Z(\Gamma)). \end{cases}$$

Assume $\Gamma(\alpha) = Z(\Gamma)$. Since the integral $\int_{\Gamma(\alpha) \backslash \mathbf{H}} \kappa(z; \alpha) dv(z)$ is convergent, the integral $\int_0^\infty r^{-1} dr$ should be convergent, which is a contradiction. Therefore $\Gamma(\alpha) \neq Z(\Gamma)$. Now we can express the integrand as

$$\frac{(e^{i\theta} - e^{-i\theta})^{k-2}}{(\eta \zeta^{-1} e^{i\theta} - e^{-i\theta})^k} = \sum_{n=1}^\infty a_n e^{2in\theta} \quad \text{or} \quad \sum_{n=1}^\infty a_n e^{-2in\theta},$$

depending on $\eta \zeta^{-1} < 1$ or $\eta \zeta^{-1} > 1$, respectively. Since the series is uniformly convergent, we have $\int_0^\pi \frac{(e^{i\theta} - e^{-i\theta})^{k-2}}{(\eta \zeta^{-1} e^{i\theta} - e^{-i\theta})^k} d\theta = 0$ by termwise integration. Therefore

$$\int_{\Gamma(\alpha) \backslash \mathbf{H}} \kappa(z; \alpha) dv(z) = 0.$$

4°. The case where α is hyperbolic and at least one fixed point of α is a cusp of Γ . In this case, we have $\Gamma(\alpha) = Z(\Gamma)$ by Lemma 1.3.3(3) and Theorem 1.5.4(2), and therefore $\Gamma(\alpha) \backslash \mathbf{H} = \mathbf{H}$. Let x_1 and x_2 be the fixed points of α . Suppose only one fixed point, say x_2 , is a cusp of Γ . Let σ, η and ζ be as in 3°, and $U = U_{x_2}$ a neighborhood of x_2 such that

$$\sigma U = \{z \in \mathbf{H} \mid |z - ia| < a\} \quad (a > 0).$$

Then similarly to 3°, we see

$$\int_{\Gamma(\alpha) \backslash (\mathbf{H} - U)} \kappa(z; \alpha, s) dv(z) = \frac{k-1}{4\pi} \det(\alpha)^{k-1} \overline{\chi(\alpha)} \zeta^{-k} \int_0^\pi \left(\frac{e^{i\theta} - e^{-i\theta}}{\eta \zeta^{-1} e^{i\theta} - e^{-i\theta}} \right)^k \frac{d\theta}{\sin^2 \theta} \int_{2a \sin \theta}^\infty \frac{dr}{r},$$

which is not finite. Therefore, both x_1 and x_2 should be cusps of Γ . Let U_v be a neighborhood of x_v ($v = 1, 2$), and put $\mathbf{H}' = \mathbf{H} - (U_1 \cup U_2)$. Divide the integral as

$$\int_{\Gamma(\alpha) \setminus \mathbf{H}} \kappa(z; \alpha, s) dv(z) = \int_{\mathbf{H}'} \kappa(z; \alpha, s) dv(z) + \int_{U_1} \kappa(z; \alpha, s) dv(z) + \int_{U_2} \kappa(z; \alpha, s) dv(z).$$

Let σ, η and ζ be the same as in 3°. We may assume $|\eta| < |\zeta|$ by exchanging x_1 and x_2 , if necessary. Put

$$\sigma U_1 = \{z \in \mathbf{H} \mid \text{Im}(z) > r_1\}, \quad \sigma U_2 = \{z \in \mathbf{H} \mid |z - ir_2| < r_2\}$$

with positive numbers $2r_2 < r_1$. Then

$$\int_{U_1} \kappa(z; \alpha, s) dv(z) = \frac{k-1}{4\pi} \det(\alpha)^{k-1} \overline{\chi(\alpha)} \zeta^{-k} \frac{1}{sr_1^2} \int_0^\pi \left(\frac{e^{i\theta} - e^{-i\theta}}{\eta \zeta^{-1} e^{i\theta} - e^{-i\theta}} \right)^k \frac{d\theta}{\sin^2 \theta} = 0.$$

Similarly we have $\int_{U_2} \kappa(z; \alpha, s) dv(z) = 0$. Next we see that

$$\begin{aligned} & \int_{\mathbf{H}'} \kappa(z; \alpha, s) dv(z) \\ &= \frac{k-1}{4\pi} \det(\alpha)^{k-1} \overline{\chi(\alpha)} \zeta^{-k} \int_0^\pi \left(\frac{e^{i\theta} - e^{-i\theta}}{\eta \zeta^{-1} e^{i\theta} - e^{-i\theta}} \right)^k \frac{d\theta}{\sin^2 \theta} \int_{\frac{r_1}{2r_2 \sin \theta}}^{\frac{r_1}{\sin \theta}} \frac{dr}{r} \\ &= \frac{2(k-1)}{\pi} \det(\alpha)^{k-1} \overline{\chi(\alpha)} \zeta^{-k} \int_0^\pi \frac{(e^{i\theta} - e^{-i\theta})^{k-2}}{(\eta \zeta^{-1} e^{i\theta} - e^{-i\theta})^k} \log(e^{i\theta} - e^{-i\theta}) d\theta. \end{aligned}$$

Integrating it by parts, we have

$$= \frac{-1}{\pi} \det(\alpha)^{k-1} \overline{\chi(\alpha)} \frac{\zeta^{-k}}{\eta \zeta^{-1} - 1} \int_0^\pi \left(\frac{e^{i\theta} - e^{-i\theta}}{\eta \zeta^{-1} e^{i\theta} - e^{-i\theta}} \right)^{k-1} \frac{e^{i\theta} + e^{-i\theta}}{e^{i\theta} - e^{-i\theta}} d\theta.$$

Expanding the integrand as the uniformly convergent series in $e^{2i\theta}$ with the constant term -1 , we obtain

$$\int_{\mathbf{H}'} \kappa(z; \alpha, s) dv(z) = -\det(\alpha)^{k-1} \overline{\chi(\alpha)} \frac{\zeta^{-k}}{\eta \zeta^{-1} - 1} = -\overline{\chi(\alpha)} \frac{|\eta|^{k-1}}{|\eta - \zeta|} \text{sgn}(\zeta)^k,$$

and therefore

$$\int_{\Gamma(\alpha) \setminus \mathbf{H}} \kappa(z; \alpha, s) dv(z) = -\overline{\chi(\alpha)} \frac{\min\{|\zeta|, |\eta|\}^{k-1}}{|\zeta - \eta|} \text{sgn}(\zeta)^k.$$

5°. The case where α is parabolic. Let x be the fixed point of α , and σ an element of $SL_2(\mathbb{R})$ such that $\sigma x = \infty$. Put

$$\sigma \alpha \sigma^{-1} = \begin{bmatrix} \zeta & \lambda \\ 0 & \zeta \end{bmatrix} \quad (\zeta, \lambda \in \mathbb{R}).$$

Suppose that x is not a cusp of Γ . Then $\Gamma(\alpha) = Z(\Gamma)$ by Lemma 1.3.3(2), and

$$\begin{aligned} & \int_{\Gamma(\alpha)\backslash\mathbf{H}} \kappa(z; \alpha) dv(z) \\ &= \frac{k-1}{4\pi} \det(\alpha)^{k-1} \overline{\chi(\alpha)} \zeta^{-k} \int_{\mathbf{H}} \left(\frac{z-\bar{z}}{z-\bar{z} + \lambda\zeta^{-1}} \right)^k dv(z). \end{aligned}$$

Since $\left(\frac{z-\bar{z}}{z-\bar{z} + \lambda\zeta^{-1}} \right)^k = y^k (y - i\lambda\zeta^{-1}/2)^{-k}$ ($y = \text{Im}(z)$), this integral is not finite.

Therefore x must be a cusp of Γ and $\Gamma(\alpha) = \Gamma_x$. Denote by T^p the set of parabolic elements of T , and put $T_x^p = T^p \cap T_x$ for each cusp x of Γ . Since $\Gamma_x = \Gamma(\alpha)$ for $\alpha \in T_x^p$, any two elements are not Γ -conjugate. Therefore we can take the set $\bigcup_{x \in \Gamma \backslash P_\Gamma} T_x^p$ as a complete set of representatives of $T^p // \Gamma$. Since $\Gamma \backslash P_\Gamma$ is a finite set, we see

$$\begin{aligned} & \lim_{s \rightarrow +0} \sum_{\alpha \in T^p // \Gamma} \int_{\Gamma(\alpha)\backslash\mathbf{H}} \kappa(z; \alpha, s) dv(z) \\ &= \sum_{x \in \Gamma \backslash P_\Gamma} \lim_{s \rightarrow +0} \sum_{\alpha \in T_x^p} \int_{\Gamma(\alpha)\backslash\mathbf{H}} \kappa(z; \alpha, s) dv(z). \end{aligned}$$

We put $\sigma\Gamma_x\sigma^{-1} \cdot \{\pm 1\} = \left\{ \pm \begin{bmatrix} 1 & mh \\ 0 & 1 \end{bmatrix} \mid m \in \mathbb{Z} \right\}$ ($h > 0$) for each $x \in P_\Gamma$ as usual, and $h(\alpha) = \lambda\zeta^{-1}$ for $\alpha \in T_x^p$. Then we see

$$\begin{aligned} & \int_{\Gamma(\alpha)\backslash\mathbf{H}} \kappa(z; \alpha, s) dv(z) \\ &= \frac{k-1}{4\pi} \det(\alpha)^{k-1} \overline{\chi(\alpha)} \zeta^{-k} \int_{\sigma\Gamma_x\sigma^{-1}\backslash\mathbf{H}} \left(\frac{z-\bar{z}}{z-\bar{z} + h(\alpha)} \right)^k \text{Im}(z)^{-s} dv(z). \end{aligned}$$

Now

$$\begin{aligned} & \int_{\sigma\Gamma_x\sigma^{-1}\backslash\mathbf{H}} \left(\frac{z-\bar{z}}{z-\bar{z} + h(\alpha)} \right)^k \text{Im}(z)^{-s} dv(z) \\ &= \int_0^h dx \int_0^\infty y^{k-2-s} (y - ih(\alpha)/2)^{-k} dy \\ &= ih(2i/h(\alpha))^{s+1} \int_0^\infty (it)^{k-2-s} (it+1)^{-k} dt \\ &= h(2i/h(\alpha))^{s+1} \int_C u^s (1-u)^{k-2-s} du \quad (it = (1-u)/u) \\ &= h(2i/h(\alpha))^{s+1} \int_0^1 u^s (1-u)^{k-2-s} du \\ &= h(2i/h(\alpha))^{s+1} \Gamma(s+1) \Gamma(k-s-1) / \Gamma(k). \end{aligned}$$

Here C is the upper (or lower) half of the circle with center $1/2$ and radius $1/2$. Thus we obtain

$$\begin{aligned} & \lim_{s \rightarrow +0} \sum_{\alpha \in T_x^p} \int_{\Gamma(\alpha) \setminus \mathbf{H}} \kappa(z; \alpha, s) dv(z) \\ &= \lim_{s \rightarrow +0} \frac{k-1}{4\pi} 2^{1+s} h^s \Gamma(s+1) \Gamma(k-s-1) / \Gamma(k) \\ & \quad \times \sum_{\alpha \in T_x^p} \overline{\chi(\alpha)} \det(\alpha)^{k-1} \zeta^{-k} (ih/h(\alpha))^{1+s} \\ &= \lim_{s \rightarrow +0} \frac{1}{2\pi} \sum_{\alpha \in T_x^p} \overline{\chi(\alpha)} \operatorname{sgn}(\zeta)^k \det(\alpha)^{k/2-1} (ih/h(\alpha))^{1+s}. \end{aligned}$$

Put $m(\alpha) = h(\alpha)/h$ and $\operatorname{sgn}(\alpha) = \operatorname{sgn}(\zeta)$, which are independent of the choice of σ . Then we obtain

$$\begin{aligned} & \lim_{s \rightarrow +0} \sum_{\alpha \in T^p // \Gamma} \int_{\Gamma(\alpha) \setminus \mathbf{H}} \kappa(z; \alpha, s) dv(z) \\ &= \lim_{s \rightarrow +0} \frac{1}{2\pi} \sum_{\alpha \in T^p // \Gamma} \overline{\chi(\alpha)} \operatorname{sgn}(\alpha)^k \det(\alpha)^{k/2-1} (i/m(\alpha))^{1+s}. \end{aligned}$$

Summing up the calculations in 1° through 5° , we obtain a formula for $\operatorname{tr}(T)$. To state it, we put

$$Z(T) = T \cap \mathbb{R}^\times, \quad T^e = \{\alpha \in T \mid \alpha \text{ is elliptic}\},$$

$$\begin{aligned} T^h &= \{\alpha \in T \mid \alpha \text{ is hyperbolic, and all fixed points of } \alpha \text{ are cusps of } \Gamma\}, \\ T^{h'} &= \{\alpha \in T \mid \alpha \text{ is hyperbolic, and no fixed point of } \alpha \text{ is a cusp of } \Gamma\} \end{aligned}$$

and

$$T^p = \{\alpha \in T \mid \alpha \text{ is parabolic, and the fixed point of } \alpha \text{ is a cusp of } \Gamma\}.$$

Then

$$T = Z(\Gamma) \cup T^e \cup T^h \cup T^{h'} \cup T^p \quad (\text{disjoint union}).$$

We note that if $\Gamma \setminus \mathbf{H}$ is compact, then $T^h = T^p = \emptyset$ and $T = Z(\Gamma) \cup T^e \cup T^{h'}$. Further for an element $\alpha \in GL_2^+(\mathbb{R})$, we use the following notations.

(6.4.8) We denote the eigen values of α by η_α and ζ_α . If α is elliptic, then take $\sigma \in SL_2(\mathbb{R})$ so that

$$\sigma \alpha \sigma^{-1} = r \begin{bmatrix} \cos \theta & \sin \theta \\ -\sin \theta & \cos \theta \end{bmatrix},$$

and specify η_α and ζ_α by

$$\eta_\alpha = r e^{i\theta}, \quad \zeta_\alpha = r e^{-i\theta}.$$

(6.4.9) For a non-elliptic α , we put $\operatorname{sgn}(\alpha) = \operatorname{sgn}(\zeta_\alpha)$.

(6.4.10) If α is parabolic, then $\eta_\alpha = \zeta_\alpha$. Denote the fixed point of α by x , and take $\sigma \in SL_2(\mathbb{R})$ so that $\sigma x = \infty$. Let Λ be a discrete subgroup of $SL_2(\mathbb{R})_x$. Then

$$\sigma \alpha \sigma^{-1} = \begin{bmatrix} \zeta & \lambda \\ 0 & \zeta \end{bmatrix}, \quad \sigma \Lambda \sigma^{-1} \cdot \{\pm 1\} = \left\{ \pm \begin{bmatrix} 1 & mh \\ 0 & 1 \end{bmatrix} \mid m \in \mathbb{Z} \right\}$$

with $\zeta = \zeta_\alpha$ and $h > 0$. We put

$$m(\alpha, A) = \lambda/h\zeta, \quad m(\alpha) = m(\alpha, \Gamma(\alpha)).$$

We note $m(\alpha, A)$ and $m(\alpha)$ are independent of the choice of σ . Now using these notations, we can write the trace of T as follows.

Theorem 6.4.9.

$$\text{tr}(T) = t_0 + t_e + t_h + t_p,$$

where

$$\begin{aligned} t_0 &= \frac{k-1}{4\pi} \frac{v(\Gamma \setminus \mathbf{H})}{|Z(\Gamma)|} \sum_{\alpha \in Z(\Gamma)} \overline{\chi(\alpha)} \text{sgn}(\alpha)^k \det(\alpha)^{k/2-1}, \\ t_e &= - \sum_{\alpha \in T^e // \Gamma} \frac{\overline{\chi(\alpha)} \eta_\alpha^{k-1}}{|\Gamma(\alpha)| \eta_\alpha - \zeta_\alpha}, \\ t_h &= - \frac{1}{|Z(\Gamma)|} \sum_{\alpha \in T^h // \Gamma} \overline{\chi(\alpha)} \text{sgn}(\alpha)^k \frac{\min\{|\zeta_\alpha|, |\eta_\alpha|\}^{k-1}}{|\zeta_\alpha - \eta_\alpha|}, \\ t_p &= \lim_{s \rightarrow +0} \frac{1}{2\pi |Z(\Gamma)|} \sum_{\alpha \in T^p // \Gamma} \overline{\chi(\alpha)} \text{sgn}(\alpha)^k \det(\alpha)^{k/2-1} (i/m(\alpha))^{1+s}. \end{aligned}$$

The terms t_e and t_p are simplified if T and χ satisfy the following condition:

(6.4.11) *there exists an element g in $GL_2(\mathbb{R})$ such that $\det(g) = -1$ and satisfies*

$$g\alpha g^{-1} \in T \quad \text{and} \quad \chi(g\alpha g^{-1}) = \chi(\alpha) \quad \text{for all } \alpha \in T.$$

In the most cases we apply the formula, (6.4.11) is satisfied. In fact, if $\Gamma = \Gamma_0(N)$, $A = A_0(N)$ and χ is the character defined by (4.3.2), it is satisfied by taking $g = \begin{bmatrix} -1 & 0 \\ 0 & 1 \end{bmatrix}$. More generally, let R be an order of level N of an indefinite quaternion algebra, $\Gamma = \Gamma_R$ and $A = A_R$. Take a maximal order R_0 including R and apply the approximation theorem (Theorem 5.2.10) to R_0 and N with $n = -1$ and $\beta_p = \begin{bmatrix} -1 & 0 \\ 0 & 1 \end{bmatrix}$ for all prime factors p of N . Take β in Theorem 5.2.10 as g , then (6.4.11) is satisfied for the character χ defined by (5.3.6).

Theorem 6.4.10. *If T and χ satisfy the condition (6.4.11), then*

$$\begin{aligned} t_e &= - \frac{1}{2} \sum_{\alpha \in T^e // \Gamma} \frac{\overline{\chi(\alpha)} \eta_\alpha^{k-1} - \zeta_\alpha^{k-1}}{|\Gamma(\alpha)| \eta_\alpha - \zeta_\alpha}, \\ t_p &= - \lim_{s \rightarrow +0} \frac{s}{4|Z(\Gamma)|} \sum_{\alpha \in T^p // \Gamma} \overline{\chi(\alpha)} \text{sgn}(\alpha)^k \det(\alpha)^{k/2-1} |m(\alpha)|^{-1-s}. \end{aligned}$$

Proof. Let g be an element satisfying (6.4.11). For each $\alpha \in T$, we put $\alpha' = g\alpha g^{-1}$. Then α' is of the same type as α , and if α is either elliptic or parabolic, then α and α' are not Γ -conjugate by Lemma 1.3.5. First suppose $\alpha \in T^e$. Take σ, η_α and ζ_α as

in (6.4.8). Put $\sigma' = \begin{bmatrix} 0 & 1 \\ 1 & 0 \end{bmatrix} \sigma g^{-1}$. Then

$$\sigma' \alpha' \sigma'^{-1} = r \begin{bmatrix} \cos(-\theta) & \sin(-\theta) \\ -\sin(-\theta) & \cos(-\theta) \end{bmatrix}, \quad \eta_{\alpha'} = \zeta_{\alpha} \quad \text{and} \quad \zeta_{\alpha'} = \eta_{\alpha}.$$

Therefore we have

$$\frac{\eta_{\alpha}^{k-1}}{\eta_{\alpha} - \zeta_{\alpha}} + \frac{\eta_{\alpha'}^{k-1}}{\eta_{\alpha'} - \zeta_{\alpha'}} = \frac{\eta_{\alpha}^{k-1} - \zeta_{\alpha}^{k-1}}{\eta_{\alpha} - \zeta_{\alpha}}.$$

Pairing α and α' in the summation $\sum_{\alpha \in T^e // \Gamma}$, we obtain the formula for t_e . Next assume $\alpha \in T^p$. Let x, σ and h be the same as in (6.4.10). Put $\sigma' = \begin{bmatrix} -1 & 0 \\ 0 & 1 \end{bmatrix} \sigma g^{-1}$ and $x' = gx$. Then x' is the fixed point of α' , and

$$\sigma' \alpha' \sigma'^{-1} = \begin{bmatrix} \zeta & -\lambda \\ 0 & \zeta \end{bmatrix}, \quad \sigma' \Gamma_{x'} \sigma'^{-1} \cdot \{\pm 1\} = \left\{ \pm \begin{bmatrix} 1 & mh \\ 0 & 1 \end{bmatrix} \mid m \in \mathbb{Z} \right\}.$$

This implies $m(\alpha') = -m(\alpha)$. Pairing α and α' , we have

$$t_p = \lim_{s \rightarrow +0} \frac{1}{4\pi |Z(\Gamma)|} (i^{1+s} + (-i)^{1+s}) \times \sum_{\alpha \in T^p // \Gamma} \overline{\chi(\alpha)} \operatorname{sgn}(\alpha)^k \det(\alpha)^{k/2-1} |m(\alpha)|^{-1-s}.$$

Since we can take the set $\bigcup_{x \in \Gamma \backslash P_{\Gamma}} T_x^p$ as a complete set of representatives of $T^p // \Gamma$,

$$t_p = \lim_{s \rightarrow +0} \frac{1}{4\pi |Z(\Gamma)|} (i^{1+s} + (-i)^{1+s}) \times \sum_{x \in \Gamma \backslash P_{\Gamma}} \sum_{\alpha \in T_x^p // \Gamma_x} \overline{\chi(\alpha)} \operatorname{sgn}(\alpha)^k \det(\alpha)^{k/2-1} \times \sum'_{\gamma \in \Gamma_x} \overline{\chi(\gamma)} \operatorname{sgn}(\gamma)^k |m(\alpha) + m(\gamma)|^{-1-s}.$$

Here \sum' implies that we omit the term $m(\alpha) + m(\gamma) = 0$. Let $\gamma_0 \in \Gamma_x$ be a generator of $\Gamma_x \cdot \{\pm 1\} / \{\pm 1\}$. Then

$$\begin{aligned} & \sum'_{\gamma \in \Gamma_x} \overline{\chi(\gamma)} \operatorname{sgn}(\gamma)^k |m(\alpha) + m(\gamma)|^{-1-s} \\ &= |Z(\Gamma)| \sum'_{n=-\infty}^{\infty} \overline{\chi(\gamma_0)^n} \operatorname{sgn}(\gamma_0)^{nk} |m(\alpha) + n|^{-1-s}, \end{aligned}$$

and it has a pole of order at most 1 at $s = 0$ by Theorem 3.2.2. Further we see that

$$\frac{1}{\pi} (i^{1+s} + (-i)^{1+s}) = -s + a_2 s^2 + a_3 s^3 + \dots$$

Therefore we obtain the formula for t_p . □

For the further calculation, we arrange each term. For $\alpha \in T^e \cup T^h \cup T^p$, we put

$$k(\alpha) = \begin{cases} \frac{\eta_\alpha^{k-1} - \zeta_\alpha^{k-1}}{\eta_\alpha - \zeta_\alpha} & (\alpha \in T^e), \\ \operatorname{sgn}(\alpha)^k \frac{\min\{|\zeta_\alpha|, |\eta_\alpha|\}^{k-1}}{|\zeta_\alpha - \eta_\alpha|} & (\alpha \in T^h), \\ \frac{s}{4} \operatorname{sgn}(\alpha)^k \det(\alpha)^{k/2-1} & (\alpha \in T^p), \end{cases}$$

and

$$l(\alpha) = \begin{cases} 1/(2|\Gamma(\alpha)|) & (\alpha \in T^e), \\ 1/|Z(\Gamma)| & (\alpha \in T^h), \\ 1/(|Z(\Gamma)| \cdot |m(\alpha)|^{s+1}) & (\alpha \in T^p). \end{cases}$$

Corollary 6.4.11. *We have*

$$t_e = - \sum_{\alpha \in T^e // \Gamma} \overline{\chi(\alpha)} k(\alpha) l(\alpha),$$

$$t_h = - \sum_{\alpha \in T^h // \Gamma} \overline{\chi(\alpha)} k(\alpha) l(\alpha),$$

and

$$t_p = - \lim_{s \rightarrow +0} \sum_{\alpha \in T^p // \Gamma} \overline{\chi(\alpha)} k(\alpha) l(\alpha).$$

If $\Gamma \backslash \mathbf{H}$ is compact, then $t_h = t_p = 0$.

§6.5. Traces of Hecke Operators (Algebraic Calculation)

In the rest of the chapter, we apply the general formula of traces of Hecke operators in §6.4 to Fuchsian groups obtained as unit groups of norm 1 of indefinite quaternion algebras. We use the notation in §5.3 for quaternion algebras.

Let B be an indefinite quaternion algebra over \mathbb{Q} with discriminant d_B , R an order of B of level N , and

$$\Gamma_R = \{\gamma \in R^\times \mid N_B(\gamma) = 1\}.$$

Let $T = \coprod \Gamma_R \alpha \Gamma_R$ be a (disjoint) union of finitely many double Γ_R -cosets included in \mathcal{A}_R . We identify T with the element $\Sigma \Gamma_R \alpha \Gamma_R$ in $\mathcal{R}(\Gamma_R, \mathcal{A}_R)$. Moreover we put

$$T_A = U_R T U_R.$$

It is a disjoint union of finitely many double U_R -cosets by Theorem 5.3.5. We identify T_A with the element $\Sigma U_R \alpha U_R$ of $\mathcal{R}(U_R, \mathcal{D}_R)$. Note that T corresponds to T_A through the isomorphism of $\mathcal{R}(\Gamma_R, \mathcal{A}_R)$ onto $\mathcal{R}(U_R, \mathcal{D}_R)$. Let χ be a Dirichlet character mod N . Then χ can be considered as a character of Γ_R by (5.3.6). The

purpose of the remaining sections of this chapter is to obtain a computable form of trace formulae of Hecke operators $T = T(n)$ defined by (5.3.12) operating on $\mathcal{S}_k(\Gamma_R, \chi)$. Hereafter we also denote Γ_R and U_R simply by Γ and U , respectively.

For the convenience of the reader, we recall the notation in the case of modular groups. In this case, $B = M_2(\mathbb{Q})$ and

$$R = \left\{ \begin{bmatrix} a & b \\ c & d \end{bmatrix} \in M_2(\mathbb{Z}) \mid c \equiv 0 \pmod{N\mathbb{Z}} \right\},$$

$$U_R = GL_2^+(\mathbb{R}) \times \prod_p R_p^\times \subset B_A^\times,$$

where

$$R_p = \left\{ \begin{bmatrix} a & b \\ c & d \end{bmatrix} \in M_2(\mathbb{Z}_p) \mid c \equiv 0 \pmod{N\mathbb{Z}_p} \right\}.$$

Therefore $\Gamma_R = U_R \cap B^\times = \Gamma_0(N)$. Moreover

$$D_p = \begin{cases} M_p(\mathbb{Z}_p) \cap GL_2(\mathbb{Q}_p) & (p \nmid N) \\ \left\{ \begin{bmatrix} a & b \\ c & d \end{bmatrix} \in R_p \mid ad - bc \neq 0, a \in \mathbb{Z}_p^\times \right\} & (p \mid N) \end{cases}$$

$$D_R = \left(GL_2^+(\mathbb{R}) \times \prod_p D_p \right) \cap GL_2(\mathbb{Q}_A),$$

$$\Delta_R = D_R \cap R = \Delta_0(N),$$

$$\mathcal{R}(\Gamma_R, \Delta_R) = \mathcal{R}(\Gamma_0(N), \Delta_0(N)) = \mathcal{R}(N).$$

As for Hecke operators, we see

$$T(n) = \{ \alpha \in \Delta_0(N) \mid \det(\alpha) = n \},$$

$$T(n)_A = U_R T(n) U_R = \left(GL_2^+(\mathbb{R}) \times \prod_p T(n)_p \right) \cap GL_2(\mathbb{Q}_A),$$

where

$$T(n)_p = \{ \alpha_p \in D_p \mid \det(\alpha_p) \in n\mathbb{Z}_p^\times \}.$$

Now we return to the initial situation in this section. We are going to calculate $T^e // \Gamma$, $T^h // \Gamma$ and $T^p // \Gamma$. For an element α of $B^\times \cap R$ not contained in \mathbb{Q} , we put

$$C(\alpha) = C_{B^\times}(\alpha) = \{ \delta \alpha \delta^{-1} \mid \delta \in B^\times \}.$$

Lemma 6.5.1. (1) *Assume $\alpha \in T^e \cup T^h \cup T^p$. Then*

$$\mathbb{Q}[\alpha] \simeq \begin{cases} \text{an imaginary quadratic field } K, & \text{if } \alpha \in T^e, \\ \mathbb{Q} \times \mathbb{Q}, & \text{if } \alpha \in T^h, \\ \mathbb{Q}[\varepsilon] \quad (\varepsilon^2 = 0), & \text{if } \alpha \in T^p. \end{cases}$$

(2) *Let S be T^e , T^h or T^p . Then for $\alpha \in S$, we have*

$$S \cap C(\alpha) = T \cap C(\alpha).$$

Proof. (1): Let $f(X) (\in \mathbb{Q}[X])$ be the principal polynomial of α . Then

$$\mathbb{Q}[\alpha] \simeq \mathbb{Q}[X]/(f(X)).$$

By definition, $f(X) = 0$ has two imaginary roots, two distinct real roots, or a multiple real root if α is elliptic, hyperbolic, or parabolic, respectively. This implies (1). (2): Since the type of any conjugate of α is the same as α , the assertion is true for $S = T^e$ or T^p . Suppose $S = T^h$. If $T^h \neq \emptyset$, then $B = M_2(\mathbb{Q})$, and therefore $P_\Gamma = \mathbb{Q} \cup \{\infty\}$, and any element of $B^\times = GL_2(\mathbb{Q})$ maps P_Γ onto itself. Therefore if α is contained in T^h , all fixed points of conjugates of α by elements of B^\times are also cusps of Γ . This implies the assertion for $S = T^h$. \square

Since

$$k(\alpha) = k(\delta\alpha\delta^{-1}) \quad \text{for any } \delta \in B^\times,$$

the above lemma implies that if $S = T^e, T^h$ or T^p , then

$$(6.5.1) \quad \sum_{\alpha \in S//\Gamma} \overline{\chi(\alpha)} k(\alpha) l(\alpha) = \sum_{\alpha \in S//B^\times} k(\alpha) \sum_{\beta \in (T \cap C(\alpha))//\Gamma} \overline{\chi(\beta)} l(\beta).$$

For any element δ of B^\times , $\mathbb{Q}[\alpha] \cap \delta^{-1}R\delta$ is an order of $\mathbb{Q}[\alpha]$. For each order \mathfrak{r} of $\mathbb{Q}[\alpha]$, we put

$$C(\alpha, \mathfrak{r}) = \{\delta\alpha\delta^{-1} \mid \delta \in B^\times, \mathbb{Q}[\alpha] \cap \delta^{-1}R\delta = \mathfrak{r}\}.$$

Since $\mathbb{Q}[\alpha] \cap \delta^{-1}R\delta$ is determined by $\beta = \delta\alpha\delta^{-1}$ and is independent of the choice of δ by Lemma 5.2.2(3), we see

$$(6.5.2) \quad C(\alpha) = \coprod_{\mathfrak{r}} C(\alpha, \mathfrak{r}),$$

where \mathfrak{r} runs over all orders of $\mathbb{Q}[\alpha]$. Suppose $\alpha \in T^e \cup T^p$. Let \mathfrak{r} be an order of $\mathbb{Q}[\alpha]$, and $\beta = \delta\alpha\delta^{-1}$ ($\delta \in B^\times$) an element of $C(\alpha, \mathfrak{r}) \cap T$. Then β is elliptic or parabolic, and $N_\beta(\varepsilon) \geq 0$ for any $\varepsilon \in \mathbb{Q}[\beta]$. This combined with Lemma 5.2.2(3) implies

$$\begin{aligned} \Gamma(\beta) &= \{\gamma \in \Gamma \mid \gamma\beta = \beta\gamma\} \\ &= \mathbb{Q}[\beta] \cap R^\times \\ &= \delta(\mathbb{Q}[\alpha] \cap \delta^{-1}R^\times\delta)\delta^{-1} \\ &= \delta\mathfrak{r}^\times\delta^{-1}. \end{aligned}$$

We put

$$(6.5.3) \quad l(\mathfrak{r}) = \begin{cases} 1/2|\mathfrak{r}^\times| & (\alpha \in T^e), \\ 1/2 & (\alpha \in T^h), \\ 1/2|m(\alpha, \mathfrak{r}^\times)|^{1+s} & (\alpha \in T^p). \end{cases}$$

Then we see

$$l(\beta) = l(\mathfrak{r}) \quad \text{for any } \beta \in C(\alpha, \mathfrak{r}),$$

since $|Z(\Gamma)| = 2$. Assume $T \cap C(\alpha, \mathfrak{r}) \neq \emptyset$ and let $\beta = \delta\alpha\delta^{-1}$ be an element of

$T \cap C(\alpha, \mathfrak{r})$. Then $\beta \in \delta \mathfrak{r} \delta^{-1}$, and therefore, $\alpha \in \mathfrak{r}$. This implies that if $T \cap C(\alpha, \mathfrak{r}) \neq \emptyset$, then $\mathfrak{r} \supset \mathbb{Z}[\alpha]$. Therefore we can rewrite (6.5.1) into

$$(6.5.4) \quad \sum_{\alpha \in S // \Gamma} \overline{\chi(\alpha)} k(\alpha) l(\alpha) \\ = \sum_{\alpha \in S // B^\times} k(\alpha) \sum_{\mathbb{Z}[\alpha] \subset \mathfrak{r}} l(\mathfrak{r}) \sum_{\beta \in (T \cap C(\alpha, \mathfrak{r})) // \Gamma} \overline{\chi(\beta)}.$$

We are going to localize the calculation of each term.

Let K be an algebra over \mathbb{Q} of dimension 2. We denote by $N_K(x)$ and $\text{tr}_K(x)$ the determinant and the trace of the regular representation of x , respectively. When K is a subalgebra of a quaternion algebra B over \mathbb{Q} , $N_K(x)$ and $\text{tr}_K(x)$ coincide with the reduced norm and the reduced trace of x in B . When K is a quadratic field, N_K and tr_K are usual ones. We note that N_K and tr_K can be extended to the mappings of K_A into \mathbb{Q}_A in the usual manner. For an order \mathfrak{r} of K , we put

$$R_A = R \otimes_{\mathbb{Z}} \mathbb{Z}_A, \\ \mathfrak{r}_A = \mathfrak{r} \otimes_{\mathbb{Z}} \mathbb{Z}_A, \\ \mathfrak{r}_{A+}^\times = \{(\alpha_v) \in \mathfrak{r}_A^\times \mid \det(\alpha_\infty) > 0\},$$

where

$$\mathbb{Z}_A = \mathbb{R} \times \prod_p \mathbb{Z}_p.$$

Moreover we put

$$h(\mathfrak{r}) = |K_A^\times / (\mathfrak{r}_{A+}^\times \cdot K^\times)|,$$

and call it the *class number* of \mathfrak{r} .

Now we return to the calculation of (6.5.4) and put

$$C_A(\alpha) = C_{B_A^\times}(\alpha) = \{h\alpha h^{-1} \mid h \in B_A^\times\}, \\ C_A(\alpha, \mathfrak{r}) = \{h\alpha h^{-1} \mid h \in B_A^\times, \mathbb{Q}_A[\alpha] \cap h^{-1} R_A h = \mathfrak{r}_A\}.$$

Obviously

$$C(\alpha) \subset C_A(\alpha), \quad C(\alpha, \mathfrak{r}) \subset C_A(\alpha, \mathfrak{r}).$$

Lemma 6.5.2. *Let α be an element of $T^e \cup T^h \cup T^p$, and θ the natural mapping of $C(\alpha) // \Gamma$ into $C_A(\alpha) // U$. Then*

- (1) θ is surjective.
- (2) If g is an element of $C_A(\alpha, \mathfrak{r})$ with an order \mathfrak{r} of $\mathbb{Q}[\alpha]$, then

$$|\theta^{-1}(C_U(g))| = h(\mathfrak{r}),$$

where

$$C_U(g) = \{ugu^{-1} \mid u \in U\}.$$

Proof. Let $g = h\alpha h^{-1}$ ($h \in B_A^\times$) be an element of $C_A(\alpha)$. Since $h = u\beta$ with $u \in U$ and $\beta \in B^\times$ by Theorem 5.2.11, we see that

$$C_U(g) = C_U(\beta\alpha\beta^{-1}).$$

This implies (1). For an element ξ of B^\times , we see that

$$C_U(\xi\alpha\xi^{-1}) = C_U(g) \Leftrightarrow \xi \in Uh\mathbb{Q}_A[\alpha]^\times \cap B^\times.$$

Moreover for two elements $\xi, \eta \in B^\times$,

$$C_{\Gamma}(\xi\alpha\xi^{-1}) = C_{\Gamma}(\eta\alpha\eta^{-1}) \Leftrightarrow \Gamma\xi\mathbb{Q}[\alpha]^\times = \Gamma\eta\mathbb{Q}[\alpha]^\times.$$

Since

$$\beta\mathbb{Q}_A[\alpha]\beta^{-1} = \mathbb{Q}_A[\beta\alpha\beta^{-1}],$$

we see

$$\begin{aligned} |\theta^{-1}(C_U(g))| &= |\Gamma \backslash (U\mathfrak{h}\mathbb{Q}_A[\alpha]^\times \cap B^\times) / \mathbb{Q}[\alpha]^\times| \\ &= |\Gamma \backslash (U\beta\mathbb{Q}_A[\alpha]^\times \cap B^\times) / \mathbb{Q}[\alpha]^\times| \\ &= |\Gamma \backslash (U\mathbb{Q}_A[\beta\alpha\beta^{-1}]^\times \cap B^\times) / \mathbb{Q}[\beta\alpha\beta^{-1}]^\times|. \end{aligned}$$

Now we are going to prove that if E is a commutative subgroup of B_A^\times , then

$$(6.5.5) \quad |\Gamma \backslash (UE \cap B^\times) / (E \cap B^\times)| = |E / (E \cap U) \cdot (E \cap B^\times)|.$$

In fact, Theorem 5.2.11 implies that for any element t of E , there exists an element u of U such that

$$ut \in UE \cap B^\times.$$

Let t_1, t_2 be two elements of E , and u_1, u_2 two elements of U . Assume that $u_1 t_1, u_2 t_2 \in UE \cap B^\times$. Noting that $\Gamma = U \cap B^\times$, we see that

$$\Gamma u_1 t_1 (E \cap B^\times) = \Gamma u_2 t_2 (E \cap B^\times) \Leftrightarrow t_1 t_2^{-1} \in (E \cap U) \cdot (E \cap B^\times).$$

This implies (6.5.5). Since

$$\mathbb{Q}_A[\beta\alpha\beta^{-1}]^\times \cap B^\times = \mathbb{Q}[\beta\alpha\beta^{-1}]^\times,$$

we can apply (6.5.5) for $E = \mathbb{Q}_A[\beta\alpha\beta^{-1}]^\times$, and see

$$\begin{aligned} |\theta^{-1}(C_U(g))| &= |\mathbb{Q}_A[\beta\alpha\beta^{-1}]^\times / (\mathbb{Q}_A[\beta\alpha\beta^{-1}] \cap U) \cdot \mathbb{Q}[\beta\alpha\beta^{-1}]^\times| \\ &= |\mathbb{Q}_A[\alpha]^\times / (\mathbb{Q}_A[\alpha] \cap \beta^{-1}U\beta) \cdot \mathbb{Q}[\alpha]^\times|. \end{aligned}$$

Now assume that $g \in C_A(\alpha, \mathfrak{r})$ with an order \mathfrak{r} of $\mathbb{Q}[\alpha]$. Then

$$\mathbb{Q}_A[\alpha] \cap \beta^{-1}U\beta = \mathfrak{r}_{A+}^\times,$$

since

$$U = GL_2^+(\mathbb{R}) \times \prod_p R_p^\times.$$

Therefore

$$|\theta^{-1}(C_U(g))| = |\mathbb{Q}_A[\alpha]^\times / \mathfrak{r}_{A+}^\times \cdot \mathbb{Q}[\alpha]^\times| = h(\mathfrak{r}). \quad \square$$

Since T_A is a union of finitely many double U -cosets, θ transforms $(T \cap C(\alpha, \mathfrak{r})) // \Gamma$ onto $(T_A \cap C_A(\alpha, \mathfrak{r})) // U$, and therefore, by Lemma 6.5.2, (6.5.4) is rewritten into

$$\begin{aligned} (6.5.6) \quad & \sum_{\alpha \in \mathcal{S} // \Gamma} \overline{\chi(\alpha)} k(\alpha) l(\alpha) \\ &= \sum_{\alpha \in \mathcal{S} // B^\times} k(\alpha) \sum_{\mathbb{Z}[\alpha] = \mathfrak{r}} l(\mathfrak{r}) h(\mathfrak{r}) \sum_{g \in (T_A \cap C_A(\alpha, \mathfrak{r})) // U} \overline{\chi(g)}. \end{aligned}$$

Now let v be either a prime number or ∞ . We put

$$T_v = R_v^\times TR_v^\times,$$

$$C_v(\alpha) = C_{B_v^\times}(\alpha) = \{x\alpha x^{-1} \mid x \in B_v^\times\}.$$

For a prime number p , let \mathfrak{r}_p be the closure of \mathfrak{r} in B_p , and put

$$C_p(\alpha, \mathfrak{r}) = \{x\alpha x^{-1} \mid x \in B_p^\times, \mathbb{Q}_p[\alpha] \cap x^{-1}R_p x = \mathfrak{r}_p\},$$

$$C_\infty(\alpha, \mathfrak{r}) = C_\infty(\alpha).$$

Moreover we write

$$R_\infty^\times = GL_2^+(\mathbb{R}).$$

Then

$$U = \prod_v R_v^\times,$$

and

$$(T_A \cap C_A(\alpha, \mathfrak{r})) // U = \prod_v \{(T_v \cap C_v(\alpha, \mathfrak{r})) // R_v^\times\},$$

where the product is taken over all prime numbers and ∞ . Therefore we obtain

$$(6.5.7) \quad \sum_{g \in (T_A \cap C_A(\alpha, \mathfrak{r})) // U} \overline{\chi(g)} = \prod_v \left(\sum_{g_v \in (T_v \cap C_v(\alpha, \mathfrak{r})) // R_v^\times} \overline{\chi_v(g_v)} \right).$$

Here if v is a prime number prime to N or ∞ , then we understand $\chi_v(g_v) = 1$.

§6.6. Local Conjugacy Classes

In this section, we calculate each factor in the right-hand side of (6.5.7). First let $v = \infty$. Since

$$C_\infty(\alpha, \mathfrak{r}) = C_\infty(\alpha) \quad \text{and} \quad T_\infty = R_\infty^\times = GL_2^+(\mathbb{R}),$$

we see

$$(T_\infty \cap C_\infty(\alpha, \mathfrak{r})) // R_\infty^\times = \{x\alpha x^{-1} \mid x \in GL_2(\mathbb{R})\} // GL_2^+(\mathbb{R}).$$

Since $GL_2^+(\mathbb{R}) \backslash GL_2(\mathbb{R}) / Z(\alpha)$ corresponds bijectively to the set in the right-hand side, Lemma 1.3.3 implies that

$$(6.6.1) \quad |(T_\infty \cap C_\infty(\alpha, \mathfrak{r})) // R_\infty^\times| = \begin{cases} 2 & \text{if } \alpha \in T^e \cup T^p, \\ 1 & \text{if } \alpha \in T^h. \end{cases}$$

Next suppose $v = p$, a prime number. We note that any algebra L over \mathbb{Q}_p of dimension 2 is isomorphic to one of the following:

- 1° a quadratic field K_p over \mathbb{Q}_p ;
- 2° $H_p = \mathbb{Q}_p \times \mathbb{Q}_p$;
- 3° $E_p = \mathbb{Q}_p[\varepsilon], \varepsilon^2 = 0$.

In fact, if x is a generator of L over \mathbb{Q}_p , and $f(X)$ is the defining polynomial of x , then

$$L \simeq \mathbb{Q}_p[X] / (f(X)).$$

We get the above three cases 1°, 2° or 3° according as the equation $f(X) = 0$ has no roots in \mathbb{Q}_p , has two distinct roots in \mathbb{Q}_p , or has a multiple root in \mathbb{Q}_p , respectively. When L is K_p , H_p or E_p , we put

$$(6.6.2) \quad \mathfrak{o}_p = \begin{cases} \text{the ring of all integral elements of } K_p & (L = K_p), \\ \mathbb{Z}_p \times \mathbb{Z}_p & (L = H_p), \\ \mathbb{Z}_p[\varepsilon] & (L = E_p). \end{cases}$$

If L is K_p or H_p , then \mathfrak{o}_p is the maximal order of L . Further we obtain

Lemma 6.6.1. *Let L be K_p , H_p or E_p . Then any order of L is*

$$\mathbb{Z}_p + p^e \mathfrak{o}_p,$$

where e is an integer. Moreover $e \geq 0$ if L is K_p or H_p .

Proof. Let \mathfrak{r}_p be an order of L . Since \mathbb{Z}_p is a principal ideal domain, we can write

$$\mathfrak{r}_p = \mathbb{Z}_p + \mathbb{Z}_p u$$

with an element $u \in \mathfrak{r}_p$. Since

$$\mathbb{Q}_p \mathfrak{r}_p = \mathbb{Q}_p \mathfrak{o}_p = L,$$

there exists an integer e such that

$$u \in \mathbb{Z}_p + p^e \mathfrak{o}_p \quad \text{and} \quad u \notin \mathbb{Z}_p + p^{e+1} \mathfrak{o}_p.$$

If L is K_p or H_p , then we see easily that $e \geq 0$. □

Now let p be a prime number prime to d_B . Then $B_p = M_2(\mathbb{Q}_p)$ and

$$(6.6.3) \quad R_p = \left\{ \begin{bmatrix} a & b \\ c & d \end{bmatrix} \in M_2(\mathbb{Z}_p) \mid c \equiv 0 \pmod{p^v} \right\}$$

with a non-negative integer v . Moreover let $N(R_p)$ be the normalizer of R_p , or

$$(6.6.4) \quad N(R_p) = \{g \in GL_2(\mathbb{Q}_p) \mid gR_p g^{-1} = R_p\}.$$

Lemma 6.6.2. *We have*

$$N(R_p) = \begin{cases} \mathbb{Q}_p^\times R_p^\times & \text{if } v = 0, \\ \mathbb{Q}_p^\times R_p^\times \cup \begin{bmatrix} 0 & 1 \\ p^v & 0 \end{bmatrix} \mathbb{Q}_p^\times R_p^\times & \text{if } v > 0. \end{cases}$$

Proof. First suppose $v = 0$. Then $R_p = M_2(\mathbb{Z}_p)$. For an element α of $GL_2(\mathbb{Q}_p)$, there exist $u_1, u_2 \in GL_2(\mathbb{Z}_p)$ such that

$$u_1 \alpha u_2 = \begin{bmatrix} p^e & 0 \\ 0 & p^f \end{bmatrix} \quad (e, f \in \mathbb{Z})$$

by elementary divisor theory. Therefore $\alpha R_p \alpha^{-1} = R_p$ if and only if $e = f$ (namely

$\alpha \in \mathbb{Q}_p^\times R_p^\times$). Next assume $v > 0$. Since there is a unique pair $(R_p^{(1)}, R_p^{(2)})$ of maximal orders of $M_2(\mathbb{Q}_p)$ such that

$$R_p = R_p^{(1)} \cap R_p^{(2)}$$

by Lemma 5.3.1, any element of $N(R_p)$ induces a permutation of $\{R_p^{(1)}, R_p^{(2)}\}$. Since we can take

$$\left(M_2(\mathbb{Z}_p), \begin{bmatrix} p^v & 0 \\ 0 & 1 \end{bmatrix}^{-1} M_2(\mathbb{Z}_p) \begin{bmatrix} p^v & 0 \\ 0 & 1 \end{bmatrix} \right)$$

for $(R_p^{(1)}, R_p^{(2)})$ in our case, we see

$$[N(R_p):\mathbb{Q}_p^\times R_p^\times] = 1 \text{ or } 2.$$

On the other hand, $\begin{bmatrix} 0 & 1 \\ p^v & 0 \end{bmatrix}$ is an element of $N(R_p)$ but does not belong to $\mathbb{Q}_p^\times R_p^\times$, so that

$$N(R_p) \neq \mathbb{Q}_p^\times R_p^\times.$$

This implies the assertion. □

Let α be a non-scalar element of R_p such that $\det(\alpha) \neq 0$, and

$$f_\alpha(X) = X^2 - tX + n \quad (t, n \in \mathbb{Z}_p)$$

be the principal polynomial of α . Let \mathfrak{r}_p be an order of $\mathbb{Q}_p[\alpha]$ including $\mathbb{Z}_p[\alpha]$. We put

$$[\mathfrak{r}_p:\mathbb{Z}_p[\alpha]] = p^\rho \quad (\rho \geq 0),$$

then Lemma 6.6.1 implies that \mathfrak{r}_p is uniquely determined by ρ . Put

$$(6.6.5) \quad \Omega(\alpha, \mathfrak{r}_p) = \{ \xi \in \mathbb{Z}_p \mid f_\alpha(\xi) \equiv 0 \pmod{p^{v+2\rho}}, t - 2\xi \equiv 0 \pmod{p^\rho} \}.$$

Furthermore, for an element $\xi \in \Omega(\alpha, \mathfrak{r}_p)$, we put

$$(6.6.6) \quad g_\xi = \begin{bmatrix} \xi & p^\rho \\ -p^{-\rho}f_\alpha(\xi) & t - \xi \end{bmatrix} \in R_p.$$

Since $f_\alpha(g_\xi) = 0$, we see

$$g_\xi \in C_p(\alpha) = \{ x\alpha x^{-1} \mid x \in GL_2(\mathbb{Q}_p) \}.$$

Lemma 6.6.3. *Let R_p be an order of $M_2(\mathbb{Z}_p)$ defined by (6.6.3), α a non-scalar element of R_p , and \mathfrak{r}_p an order of $\mathbb{Q}_p[\alpha]$ such that*

$$\mathfrak{r}_p \supset \mathbb{Z}_p[\alpha] \quad \text{and} \quad [\mathfrak{r}_p:\mathbb{Z}_p[\alpha]] = p^\rho \quad (\rho \geq 0).$$

For an element g of $C_p(\alpha)$, the following four statements are equivalent.

- (1) $g \in C_p(\alpha, \mathfrak{r}_p)$.
- (2) $g \in \mathbb{Z}_p + p^\rho R_p$, and $g \notin \mathbb{Z}_p + p^{\rho+1} R_p$.

(3) If $g = \begin{bmatrix} a & b \\ c & d \end{bmatrix}$, then

$$b \equiv a - d \equiv 0 \pmod{p^\rho}, \quad c \equiv 0 \pmod{p^{\rho+\nu}},$$

and any one of the following three conditions is satisfied:

- (i) $b \not\equiv 0 \pmod{p^{\rho+1}}$;
- (ii) $c \not\equiv 0 \pmod{p^{\rho+\nu+1}}$;
- (iii) $a - d \not\equiv 0 \pmod{p^{\rho+1}}$.

(4) There exists an element $\xi \in \Omega(\alpha, r_p)$ such that g is $N(R_p)$ -conjugate to g_ξ .

Proof. (1) \Leftrightarrow (2): Put $g = h\alpha h^{-1}$ with $h \in GL_2(\mathbb{Q}_p)$. Then

$$\begin{aligned} g \in C_p(\alpha, r_p) &\Leftrightarrow \mathbb{Q}_p[g] \cap R_p = hr_p h^{-1} \\ &\Leftrightarrow [\mathbb{Q}_p[g] \cap R_p : \mathbb{Z}_p[g]] = p^\rho \\ &\Leftrightarrow \mathbb{Z}_p[g] = \mathbb{Z}_p + \mathbb{Q}_p[g] \cap p^\rho R_p \end{aligned}$$

by Lemma 6.6.1. This implies the equivalence of (1) and (2). (2) \Leftrightarrow (3): This follows from the definition of R_p . (4) \Rightarrow (2): Suppose that g is $N(R_p^\times)$ -conjugate to g_ξ with an element $\xi \in \Omega(\alpha, r_p)$. Since g_ξ always satisfies (3), it does (2), so that $\begin{bmatrix} 0 & 1 \\ p^\nu & 0 \end{bmatrix} g_\xi \begin{bmatrix} 0 & 1 \\ p^\nu & 0 \end{bmatrix}^{-1}$ also satisfies (2). This combined with Lemma 6.6.2 implies that g satisfies (2). (3) \Rightarrow (4): Suppose that g satisfies (3). First assume condition (i), and put

$$b = p^\rho b_1 \quad (b_1 \in \mathbb{Z}_p^\times).$$

Since g is conjugate to α , we see $f_\alpha(g) = 0$. In particular,

$$t = a + d, \quad n = ad - bc,$$

so that

$$f_\alpha(a) = -bc \equiv 0 \pmod{p^{\nu+2\rho}},$$

and

$$t - 2a \equiv 0 \pmod{p^\rho}.$$

Thus $a \in \Omega(\alpha, r_p)$. Moreover we see

$$ugu^{-1} = g_a \quad \left(u = \begin{bmatrix} 1 & 0 \\ 0 & b_1 \end{bmatrix} \in R_p^\times \right).$$

Next suppose that g satisfies condition (ii). Since $\begin{bmatrix} 0 & 1 \\ p^\nu & 0 \end{bmatrix} g \begin{bmatrix} 0 & 1 \\ p^\nu & 0 \end{bmatrix}^{-1}$ satisfies condition (i), it is R_p^\times -conjugate to g_ξ with some $\xi \in \Omega(\alpha, r_p)$. Lastly assume condition (iii). We may suppose that

$$b \equiv 0 \pmod{p^{\rho+1}}, \quad c \equiv 0 \pmod{p^{\rho+\nu+1}}.$$

Then

$$ugu^{-1} = \begin{bmatrix} a+c & -a+d+b-c \\ c & -c+d \end{bmatrix}$$

with $u = \begin{bmatrix} 1 & 1 \\ 0 & 1 \end{bmatrix} \in R_p^\times$, and

$$-a + d + b - c \not\equiv 0 \pmod{p^{\rho+1}}.$$

This implies that ugu^{-1} satisfies (i) and it is R_p^\times -conjugate to g_ξ . □

If $v \geq 1$, we put

$$(6.6.7) \quad w = \begin{bmatrix} 0 & 1 \\ p^v & 0 \end{bmatrix} \in N(R_p).$$

Then for $\xi \in \Omega(\alpha, r_p)$,

$$(6.6.8) \quad wg_\xi w^{-1} = \begin{bmatrix} t - \xi & -f_\alpha(\xi)/p^{v+\rho} \\ p^{v+\rho} & \xi \end{bmatrix},$$

and both g_ξ and $wg_\xi w^{-1}$ belong to $C_p(\alpha, r_p)$. Lemma 6.6.3 implies

$$(6.6.9) \quad C_p(\alpha, r_p) // R_p^\times = \begin{cases} \{g_\xi \mid \xi \in \Omega(\alpha, r_p)\} // R_p^\times, & (v = 0), \\ \{g_\xi, wg_\xi w^{-1} \mid \xi \in \Omega(\alpha, r_p)\} // R_p^\times, & (v \geq 1). \end{cases}$$

Lemma 6.6.4. *Assume $v \geq 1$. Then $g = \begin{bmatrix} a & b \\ c & d \end{bmatrix} \in C_p(\alpha, r_p)$ is R_p^\times -conjugate to some g_ξ ($\xi \in \Omega(\alpha, r_p)$) if and only if*

$$b \not\equiv 0 \pmod{p^{\rho+1}} \quad \text{or} \quad a - d \not\equiv 0 \pmod{p^{\rho+1}}.$$

Proof. The if-part was already proved in the proof of the (3) \Rightarrow (4) of Lemma 6.6.3. Now assume that

$$b \equiv a - d \equiv 0 \pmod{p^{\rho+1}},$$

and

$$ugu^{-1} = g_\xi \quad \left(u = \begin{bmatrix} a' & b' \\ c' & d' \end{bmatrix} \in R_p^\times, \xi \in \Omega(\alpha, r_p) \right).$$

Since $c \equiv 0 \pmod{p^{v+\rho}}$ by Lemma 6.6.3, we see

$$\begin{aligned} g_\xi &= ugu^{-1} \\ &\equiv \begin{bmatrix} * & \{-a'b'(a-d) + a'^2b\} / (a'd' - b'c') \\ * & * \end{bmatrix} \pmod{p^{v+\rho}}. \end{aligned}$$

Since

$$-a'b'(a-d) + a'^2b \equiv 0 \pmod{p^{\rho+1}},$$

this contradicts the definition of g_ξ . □

Lemma 6.6.5. *Let ξ, η be two elements of $\Omega(\alpha, r_p)$.*

(1) g_ξ and g_η are R_p^\times -conjugate if and only if

$$\xi \equiv \eta \pmod{p^{v+\rho}}.$$

(2) Suppose $v \geq 1$. Then g_ξ and $wg_\eta w^{-1}$ are R_p^\times -conjugate if and only if ξ and η satisfy the following two conditions:

- (i) $t^2 - 4n \not\equiv 0 \pmod{p^{2\rho+1}}$ or $f_\alpha(\eta) \not\equiv 0 \pmod{p^{v+2\rho+1}}$,
- (ii) $\xi \equiv t - \eta \pmod{p^{v+\rho}}$.

Proof. (1): First suppose $\xi \equiv \eta \pmod{p^{v+\rho}}$. Then

$$u = \begin{bmatrix} 1 & 0 \\ p^{-\rho}(\xi - \eta) & 1 \end{bmatrix} \in R_p^\times$$

and

$$ug_\xi u^{-1} = g_\eta.$$

Conversely assume $g_\eta = ug_\xi u^{-1}$ with $u \in R_p^\times$. Since

$$g_\xi - \xi \equiv 0 \pmod{p^\rho},$$

we see

$$p^{-\rho}(g_\xi - \xi) \in R_p,$$

so that

$$p^{-\rho}(g_\eta - \xi) = up^{-\rho}(g_\xi - \xi)u^{-1} \in R_p.$$

Since u is congruent mod p^v to an upper triangular matrix, we get

$$p^{-\rho}(\eta - \xi) \equiv 0 \pmod{p^v}.$$

Thus $\eta \equiv \xi \pmod{p^{v+\rho}}$. (2): By definition, we have

$$wg_\eta w^{-1} = \begin{bmatrix} t - \eta & -p^{-\rho-v}f_\alpha(\eta) \\ p^{v+\rho} & \eta \end{bmatrix} \in C_p(\alpha, r_p).$$

By Lemma 6.6.4 and an argument similar to (1), g_ξ and $wg_\eta w^{-1}$ are R_p^\times -conjugate if and only if they satisfy

- (i') $f_\alpha(\eta) \not\equiv 0 \pmod{p^{v+2\rho+1}}$ or $2\eta - t \not\equiv 0 \pmod{p^{\rho+1}}$,
- (ii) $\xi \equiv t - \eta \pmod{p^{v+\rho}}$.

Since

$$t = \eta + (t - \eta) \quad \text{and} \quad \eta(t - \eta) \equiv n \pmod{p^{v+2\rho}},$$

we see

$$t^2 - 4n \equiv (2\eta - t)^2 \pmod{p^{v+2\rho}}.$$

Therefore (i') is equivalent to (i). □

Now we assume $\Omega(\alpha, r_p) \neq \emptyset$ and let ξ be an element of $\Omega(\alpha, r_p)$. Then

$$t^2 - 4n \equiv (t - 2\xi)^2 \pmod{p^{v+2\rho}}.$$

Therefore we obtain

$$(6.6.10) \quad t^2 - 4n \equiv 0 \pmod{p^{2\rho}}$$

by the definition of $\Omega(\alpha, r_p)$. Conversely suppose that α satisfies (6.6.10). If $\xi \in \mathbb{Z}_p$ satisfies

$$f_\alpha(\xi) \equiv 0 \pmod{p^{v+2\rho}},$$

then

$$t - 2\xi \equiv 0 \pmod{p^\rho}.$$

Therefore

$$(6.6.11) \quad \Omega(\alpha, \mathfrak{r}_p) = \begin{cases} \{\xi \in \mathbb{Z}_p \mid f_\alpha(\xi) \equiv 0 \pmod{p^{v+2\rho}}\}, & \text{if } t^2 - 4n \equiv 0 \pmod{p^{2\rho}}, \\ \emptyset, & \text{otherwise.} \end{cases}$$

Further we put

$$(6.6.12) \quad \Omega'(\alpha, \mathfrak{r}_p) = \begin{cases} \{\xi \in \mathbb{Z}_p \mid f_\alpha(\xi) \equiv 0 \pmod{p^{v+2\rho+1}}\}, & \text{if } t^2 - 4n \equiv 0 \pmod{p^{2\rho+1}} \text{ and } v \geq 1, \\ \emptyset, & \text{otherwise.} \end{cases}$$

Then we have the following

Theorem 6.6.6. *Assume $v \geq 1$. Let α be a non-scalar element of R_p , and $f_\alpha(X) = X^2 - tX + n$ the principal polynomial of α . For any order \mathfrak{r}_p of $\mathbb{Q}[\alpha]$ including $\mathbb{Z}_p[\alpha]$ such that*

$$[\mathfrak{r}_p : \mathbb{Z}_p[\alpha]] = p^\rho,$$

we can take as a complete set of representatives of $C_p(\alpha, \mathfrak{r}_p) // R_p^\times$ the set

$$\{g_\xi \mid \xi \in \Omega/p^{v+\rho}\} \cup \{wg_\xi w^{-1} \mid \xi \in \Omega'/p^{v+\rho}\},$$

where $\Omega/p^{v+\rho}$ (resp. $\Omega'/p^{v+\rho}$) is a complete set of representatives of $\Omega(\alpha, \mathfrak{r}_p) \pmod{p^{v+\rho}}$ (resp. $\Omega'(\alpha, \mathfrak{r}_p) \pmod{p^{v+\rho}}$).

Theorem 6.6.7. *If $R_p = M_2(\mathbb{Z}_p)$, then $|C_p(\alpha, \mathfrak{r}_p) // R_p^\times| = 1$.*

Proof. Since any order \mathfrak{r}_p of $\mathbb{Q}_p[\alpha]$ is a \mathbb{Z}_p -free module, we can write

$$\mathfrak{r}_p = \mathbb{Z}_p[\beta] \quad \text{with } \beta \in \mathbb{Q}_p[\alpha].$$

Put

$$\beta = a + b\alpha \quad (a, b \in \mathbb{Q}_p).$$

Then $C_p(\alpha, \mathfrak{r}_p) // R_p^\times$ corresponds bijectively to $C_p(\beta, \mathfrak{r}_p) // R_p^\times$ through the correspondence “ $g \mapsto a + bg$ ”. Since

$$[\mathfrak{r}_p : \mathbb{Z}_p[\beta]] = 1,$$

we see that

$$\rho = 0, \quad \text{and} \quad \Omega(\beta, \mathfrak{r}_p) = \mathbb{Z}_p.$$

Therefore by Lemma 6.6.5(1), we obtain

$$|C_p(\alpha, \mathfrak{r}_p) // R_p^\times| = |C_p(\beta, \mathfrak{r}_p) // R_p^\times| = 1. \quad \square$$

Next we consider the case when p divides d_B . Then B_p is a division algebra, and

$$R_p = \{\alpha \in B_p \mid N_{B_p}(\alpha), \text{tr}_{B_p}(\alpha) \in \mathbb{Z}_p\}$$

is a unique maximal order of B_p by Lemma 5.2.3(1). Therefore, for any non-scalar element α of B_p^\times , we see

$$C_p(\alpha) \cap R_p \neq \emptyset \quad \text{if and only if } \alpha \in R_p.$$

Let α be a non-scalar element of R_p . Since $\mathbb{Q}_p[\alpha] \cap R_p$ is a unique maximal order of $\mathbb{Q}_p[\alpha]$, we see

$$(6.6.13) \quad |C_p(\alpha, \tau_p) // B_p^\times| = \begin{cases} 1, & \text{if } \tau_p \text{ is the maximal order of } \mathbb{Q}_p[\alpha], \\ 0, & \text{otherwise.} \end{cases}$$

Since any two-sided ideal of R_p is given by $\pi_p^n R_p$ ($\pi_p^2 R_p = pR_p$, $n \geq 0$), and

$$B_p = \bigcup_{n=0}^{\infty} \pi_p^{-n} R_p,$$

we get

$$(6.6.14) \quad B_p = \begin{cases} \mathbb{Q}_p[\alpha] R_p, & \text{if } p \text{ ramifies in } \mathbb{Q}_p[\alpha], \\ \mathbb{Q}_p[\alpha] R_p \cup \pi_p \mathbb{Q}_p[\alpha] R_p, & \text{otherwise.} \end{cases}$$

Since p ramifies in B_p by assumption, p does not split in $\mathbb{Q}_p[\alpha]$. Taking this into account, we obtain the following

Theorem 6.6.8. *Let B_p be a division quaternion algebra, R_p the maximal order of B_p , and α a non-scalar element of R_p . For an order τ_p of $\mathbb{Q}_p[\alpha]$, we have*

$$C_p(\alpha, \tau_p) // R_p^\times = \begin{cases} \emptyset, & \text{if } \tau_p \text{ is not maximal,} \\ \{\alpha\}, & \text{if } \tau_p \text{ is maximal and } p \text{ ramifies} \\ & \text{in } \mathbb{Q}_p[\alpha], \\ \{\alpha, \pi_p \alpha \pi_p^{-1}\}, & \text{if } \tau_p \text{ is maximal and } p \text{ remains} \\ & \text{prime in } \mathbb{Q}_p[\alpha]. \end{cases}$$

Now using (6.6.1), Theorem 6.6.7 and Theorem 6.6.8, we calculate the right-hand side of (6.5.7) and obtain

$$(6.6.15) \quad \sum_{g \in (T_A \cap C_A(\alpha, \tau)) // U} \overline{\chi(g)} = v \prod_{p|N} \left\{ \sum_{\substack{\xi \in \Omega/p^{v+p} \\ g_\xi \in T_p}} \chi_p(\xi) + \sum_{\substack{\xi \in \Omega'/p^{v+p} \\ wg_\xi w^{-1} \in T_p}} \chi_p(t - \xi) \right\}.$$

Here N is the level of R ; $t = \text{tr}(\alpha)$; $\Omega = \Omega(\alpha, \tau_p)$, $\Omega' = \Omega'(\alpha, \tau_p)$; and

$$(6.6.16) \quad v = \begin{cases} 0 & \text{if } \alpha \in T^e, \tau_p \neq \max \text{ for some } p|d_B, \\ 2^{1+u} & \text{if } \alpha \in T^e, \tau_p = \max \text{ for all } p|d_B, \\ 1 & \text{if } \alpha \in T^h, \\ 2 & \text{if } \alpha \in T^p, \end{cases}$$

where the integer u for $\alpha \in T^e$ is given by

$$(6.6.17) \quad u = \#\{\text{prime numbers unramified in } \mathbb{Q}[\alpha]\}.$$

§ 6.7. Class Numbers of Orders of $\mathbb{Q}[\alpha]$

In this section, we calculate the class number $h(\mathfrak{r})$ of an order \mathfrak{r} of $\mathbb{Q}[\alpha]$.

Lemma 6.7.1. *Let p be a prime number.*

(1) *Let $K = \mathbb{Q}(\sqrt{d})$ be a quadratic field with discriminant d , \mathfrak{r}_0 the maximal order of K , and \mathfrak{r} an order of K . Put*

$$\mathfrak{r}_{0p} = \mathfrak{r}_0 \otimes_{\mathbb{Z}} \mathbb{Z}_p$$

and

$$\mathfrak{r}_p = \mathfrak{r} \otimes_{\mathbb{Z}} \mathbb{Z}_p.$$

If

$$[\mathfrak{r}_{0p} : \mathfrak{r}_p] = p^e \quad (e > 0),$$

then

$$[\mathfrak{r}_{0p}^\times : \mathfrak{r}_p^\times] = p^e \left(1 - \left(\frac{d}{p} \right) p^{-1} \right),$$

where $(-)$ is the Legendre symbol.

(2) *Let*

$$H_p = \mathbb{Q}_p \times \mathbb{Q}_p,$$

$$\mathfrak{r}_0 = \mathbb{Z}_p \times \mathbb{Z}_p,$$

and \mathfrak{r} be an order of H_p . If

$$[\mathfrak{r}_0 : \mathfrak{r}] = p^e \quad (e > 0),$$

then

$$[\mathfrak{r}_0^\times : \mathfrak{r}^\times] = p^e (1 - p^{-1}).$$

(3) *Let*

$$E_p = \mathbb{Q}_p[\varepsilon] \quad (\varepsilon^2 = 0),$$

and $\mathfrak{r}_1, \mathfrak{r}_2$ be two orders of E_p . If $\mathfrak{r}_1 \supset \mathfrak{r}_2$ and

$$[\mathfrak{r}_1 : \mathfrak{r}_2] = p^e \quad (e > 0),$$

then

$$[\mathfrak{r}_1^\times : \mathfrak{r}_2^\times] = p^e.$$

Proof. We begin by proving (2). By Lemma 6.6.1, we have

$$\mathfrak{r} = \mathbb{Z}_p + p^e \mathfrak{r}_0 = \{(a, b) \in \mathfrak{r}_0 \mid a \equiv b \pmod{p^e}\}.$$

Since

$$\mathfrak{r}_0^\times = \mathbb{Z}_p^\times \times \mathbb{Z}_p^\times,$$

we see

$$\mathfrak{r}_0^\times / \mathfrak{r}^\times \simeq (\mathbb{Z}/p^e\mathbb{Z})^\times$$

by the correspondence “ $(a, b) \mapsto a/b$ ”. Therefore we get

$$[\mathfrak{r}_0^\times : \mathfrak{r}^\times] = p^e (1 - p^{-1}).$$

Next let us prove (3). We can write

$$\mathfrak{r}_1 = \mathbb{Z}_p + p^f \mathbb{Z}_p \varepsilon \quad \text{and} \quad \mathfrak{r}_2 = \mathbb{Z}_p + p^{e+f} \mathbb{Z}_p \varepsilon$$

with some integer f by Lemma 6.6.1. Thus

$$\mathfrak{r}_1^\times = \mathbb{Z}_p^\times + p^f \mathbb{Z}_p \varepsilon \quad \text{and} \quad \mathfrak{r}_2^\times = \mathbb{Z}_p^\times + p^{e+f} \mathbb{Z}_p \varepsilon,$$

so that

$$\mathfrak{r}_1^\times / \mathfrak{r}_2^\times \simeq \mathbb{Z}_p / p^e \mathbb{Z}_p$$

through the correspondence " $a + p^f b \varepsilon \mapsto b/a$ ". Therefore we get

$$[\mathfrak{r}_1^\times : \mathfrak{r}_2^\times] = p^e.$$

Lastly we are going to prove (1). Put

$$K_p = K \otimes_{\mathbb{Q}} \mathbb{Q}_p.$$

If p splits in K , then

$$K_p \simeq \mathbb{Q}_p \times \mathbb{Q}_p,$$

so that this case is reduced to (2). Assume that p remains prime or ramifies in K . The K_p is a quadratic field over \mathbb{Q}_p , and

$$\mathfrak{r}_p = \mathbb{Z}_p + p^e \mathfrak{r}_{0p}$$

by Lemma 6.6.1. Then the sequence

$$1 \rightarrow \mathbb{Z}_p^\times / (1 + p^e \mathbb{Z}_p) \rightarrow \mathfrak{r}_{0p}^\times / (1 + p^e \mathfrak{r}_{0p}) \rightarrow \mathfrak{r}_{0p}^\times / \mathfrak{r}_p^\times \rightarrow 1$$

is exact,

$$\begin{aligned} |\mathfrak{r}_{0p}^\times / (1 + p^e \mathfrak{r}_{0p})| &= |(\mathfrak{r}_{0p} / p^e \mathfrak{r}_{0p})^\times| \\ &= \begin{cases} p^{2e}(1 - p^{-2}) & (p: \text{remains prime}), \\ p^{2e}(1 - p^{-1}) & (p: \text{ramifies}) \end{cases} \end{aligned}$$

and

$$|\mathbb{Z}_p^\times / (1 + p^e \mathbb{Z}_p)| = |(\mathbb{Z}_p / p^e \mathbb{Z}_p)^\times| = p^e(1 - p^{-1}),$$

so that we get (1). □

Class numbers are given by the following

Theorem 6.7.2. (1) Let $K = \mathbb{Q}(\sqrt{d})$ be an imaginary quadratic field with discriminant d , \mathfrak{r}_0 the maximal order of K . If \mathfrak{r} is an order of K and

$$[\mathfrak{r}_0 : \mathfrak{r}] = n,$$

then

$$h(\mathfrak{r}) = \frac{h_K \cdot n \prod_{p|n} \left(1 - \left(\frac{d}{p}\right) p^{-1}\right)}{[\mathfrak{r}_0^\times : \mathfrak{r}^\times]},$$

where $h_K = h(\mathfrak{r}_0)$ is the class number of K .

(2) Let $H = \mathbb{Q} \times \mathbb{Q}$, and \mathfrak{r} an order of H . If

$$[\mathbb{Z} \times \mathbb{Z} : \mathfrak{r}] = n,$$

then

$$h(\mathfrak{r}) = n \prod_{p|n} (1 - p^{-1}).$$

(3) Let $E = \mathbb{Q}[\varepsilon]$ ($\varepsilon^2 = 0$). If \mathfrak{r} is an order of E , then

$$h(\mathfrak{r}) = 1.$$

Proof. (1): By definition, we see that $\mathfrak{r}_{A^+}^\times = \mathfrak{r}_A^\times$ and

$$\begin{aligned} h(\mathfrak{r}) &= |K_A^\times / K^\times \mathfrak{r}_A^\times| = |K_A^\times / K^\times \mathfrak{r}_{0A}^\times| \cdot |K^\times \mathfrak{r}_{0A}^\times / K^\times \mathfrak{r}_A^\times| \\ &= h_K |\mathfrak{r}_{0A}^\times / \mathfrak{r}_A^\times| \cdot |(K^\times \cap \mathfrak{r}_{0A}^\times) / (K^\times \cap \mathfrak{r}_A^\times)|^{-1}. \end{aligned}$$

Since K is imaginary, we see

$$K^\times \cap \mathfrak{r}_{0A}^\times = \mathfrak{r}_0^\times \quad \text{and} \quad K^\times \cap \mathfrak{r}_A^\times = \mathfrak{r}^\times.$$

This combined with Lemma 6.7.1(1) implies (1). (2): Put

$$\mathfrak{r}_0 = \mathbb{Z} \times \mathbb{Z}.$$

Similarly as above, we have

$$h(\mathfrak{r}) = |H_A^\times / H^\times \mathfrak{r}_{0A^+}^\times| \cdot |\mathfrak{r}_{0A^+}^\times / \mathfrak{r}_{A^+}^\times| \cdot |(H^\times \cap \mathfrak{r}_{0A^+}^\times) / (H^\times \cap \mathfrak{r}_{A^+}^\times)|^{-1}.$$

Lemma 6.6.1 implies

$$\mathfrak{r} = \{(a, b) \in \mathfrak{r}_0 \mid a \equiv b \pmod{n}\},$$

so that

$$H^\times \cap \mathfrak{r}_{0A}^\times = H^\times \cap \mathfrak{r}_A^\times = \{(1, 1), (-1, -1)\}.$$

Moreover, since

$$\mathbb{Q}_A^\times = \mathbb{Q}^\times \mathbb{Z}_A^\times,$$

we see

$$H_A^\times = H^\times \mathfrak{r}_{0A^+}^\times.$$

Therefore we get

$$h(\mathfrak{r}) = [\mathfrak{r}_{0A^+}^\times : \mathfrak{r}_{A^+}^\times] = n \prod_{p \mid n} (1 - p^{-1})$$

by Lemma 6.7.1(2). (3): We see

$$\mathfrak{r} = \{a + t b \varepsilon \mid a, b \in \mathbb{Z}\}$$

with some $t \in \mathbb{Q}^\times$ by Lemma 6.6.1. Since

$$E_A^\times = \mathbb{Q}_A^\times (1 + \mathbb{Q}_A \varepsilon),$$

$$E^\times = \mathbb{Q}^\times (1 + \mathbb{Q} \varepsilon),$$

and

$$\mathfrak{r}_A^\times = \mathbb{Z}_A^\times (1 + t \mathbb{Z}_A \varepsilon),$$

we see that $\mathfrak{r}_{A^+}^\times = \mathfrak{r}_A^\times$ and

$$\begin{aligned} h(\mathfrak{r}) &= |E_A^\times / E^\times \mathfrak{r}_A^\times| \\ &= |(1 + \mathbb{Q}_A \varepsilon) / (1 + \mathbb{Q} \varepsilon)(1 + t \mathbb{Z}_A \varepsilon)| \\ &= |\mathbb{Q}_A / (\mathbb{Q} + \mathbb{Z}_A)| = 1. \end{aligned}$$

□

Remark 6.7.1. As for the class number h_K , see [Borevich–Shafarevich]. When K is an imaginary quadratic field, we easily see

$$r^\times = \begin{cases} \{\pm 1, \pm \sqrt{d-1}\} & \text{if } K = \mathbb{Q}(\sqrt{-1}) \text{ and } r \text{ is maximal,} \\ \{\pm 1, \pm e^{\pi i/3}, \pm e^{2\pi i/3}\} & \text{if } K = \mathbb{Q}(\sqrt{-3}) \text{ and } r \text{ is maximal,} \\ \{\pm 1\} & \text{otherwise.} \end{cases}$$

§6.8. An Explicit Formula for $\text{tr}(T(n))$

Finally in this section, we present an explicit form of $\text{tr}(T(n))$. First we calculate the terms for elliptic α 's.

Lemma 6.8.1. *Let $K = \mathbb{Q}(\sqrt{d})$ be a quadratic field with discriminant d , and r_0 the ring of integers of K . For an element α of r_0 ($\alpha \notin \mathbb{Z}$), let $X^2 - tX + n$ be the minimal polynomial of α . If m is the positive integer given by*

$$t^2 - 4n = m^2d,$$

then

$$[r_0 : \mathbb{Z}[\alpha]] = m.$$

Proof. It is easily seen that $r_0 = \mathbb{Z} + \mathbb{Z}\delta$ with $\delta = (d + \sqrt{d})/2$. Put $\alpha = l + m\delta$ ($l, m \in \mathbb{Z}$), then $t^2 - 4n = m^2d$. Since $\mathbb{Z}[\alpha] = \mathbb{Z}[m\delta]$, we get $[r_0 : \mathbb{Z}[\alpha]] = m$. \square

Notation being as above, we suppose that K is imaginary. For any positive integer f , there uniquely exists an order r of K such that $[r_0 : r] = f$; in fact, $r = \mathbb{Z} + fr_0$. We put

$$h(f^2d) = h(r), \quad w(f^2d) = |r^\times|.$$

Then Theorem 6.7.2 implies

$$\frac{h(f^2d)}{w(f^2d)} = \frac{h(d)}{w(d)} \cdot f \prod_{p|f} \left(1 - \left(\frac{d}{p}\right) p^{-1} \right).$$

Let α be an element of T^e . Then $\mathbb{Q}[\alpha]$ is isomorphic to an imaginary quadratic field $\mathbb{Q}(\sqrt{d})$ with discriminant d . Let $f_\alpha(X) = X^2 - tX + n$ be the minimal polynomial of α . We define $m (> 0)$ by $t^2 - 4n = m^2d$. Then by Lemma 6.8.1 combined with (6.5.3) and (6.6.15), we obtain

$$(6.8.1) \quad \sum_{\mathbb{Z}[\alpha] \subset r} l(r)h(r) \sum_{g \in (T_A \cap C_A(\alpha, r))//U} \overline{\chi(g)} \\ = 2^u \sum_{0 < f|m} \frac{h(f^2d)}{w(f^2d)} \prod_{p|N} \left\{ \sum_{\substack{\xi \in \Omega/p^{v+\rho} \\ g_\xi \in T_p}} \chi_p(\xi) + \sum_{\substack{\xi \in \Omega'/p^{v+\rho} \\ wg_\xi w^{-1} \in T_p}} \chi_p(t - \xi) \right\}.$$

where r runs over all orders of $\mathbb{Q}[\alpha]$ including $\mathbb{Z}[\alpha]$, and $\rho = \text{ord}_p(m/f)$ ($= \max\{\mu \in \mathbb{Z} \mid p^\mu \mid (m/f)\}$).

Now take $T(n)$ for T . Then Lemma 5.2.5, (6.5.6) and (6.8.1) imply

$$\begin{aligned}
 (6.8.2) \quad & \sum_{\alpha \in T(n)^\epsilon // \Gamma} \overline{\chi(\alpha)} k(\alpha) l(\alpha) \\
 &= \sum'_{\substack{t \in \mathbb{Z} \\ t^2 - 4n = m^2 d < 0}} 2^u \frac{\eta^{k-1} - \zeta^{k-1}}{\eta - \zeta} \\
 & \times \sum_{\substack{0 < f \mid m \\ (f, d_B) = 1}} \frac{h(f^2 d)}{w(f^2 d)} \prod_{p \mid N} \left\{ \sum_{\xi \in \Omega/p^{v+p}} \chi_p(\xi) + \sum_{\xi \in \Omega'/p^{v+p}} \chi_p(t - \xi) \right\}.
 \end{aligned}$$

Here η, ζ are the roots of $X^2 - tX + n = 0$; for each t, m (> 0) is given by $t^2 - 4n = m^2 d$ with the discriminant d of the quadratic field $\mathbb{Q}(\zeta)$; $\rho = \text{ord}_p(m/f)$; for p, t and f , and Ω and Ω' are given by

$$(6.8.3) \quad \Omega = \Omega(t, f, p) = \{ \xi \in \mathbb{Z}_p \mid \xi^2 - t\xi + n \equiv 0 \pmod{(m/f)^2 N \mathbb{Z}_p} \},$$

and

$$\begin{aligned}
 (6.8.4) \quad \Omega' &= \Omega'(t, f, p) \\
 &= \begin{cases} \{ \xi \in \mathbb{Z}_p \mid \xi^2 - t\xi + n \equiv 0 \pmod{p(m/f)^2 N \mathbb{Z}_p} \}, & \text{if } df \equiv 0 \pmod{p}, \\ \emptyset, & \text{otherwise.} \end{cases}
 \end{aligned}$$

Let us proceed to the case T^h . The following lemma is easily proved.

Lemma 6.8.2. *Let $H = \mathbb{Q} \times \mathbb{Q}$, $r_0 = \mathbb{Z} \times \mathbb{Z}$, $\alpha \in r_0 - \mathbb{Z}$, and let $X^2 - tX + n$ be the minimal polynomial of α . Then*

$$t^2 - 4n = m^2 \quad (m > 0),$$

and

$$[r_0 : \mathbb{Z}[\alpha]] = m.$$

Let α be an element of T^h . Then $\mathbb{Q}[\alpha] \simeq \mathbb{Q} \times \mathbb{Q}$. Similarly to the elliptic case, Lemma 6.8.2 and Theorem 6.7.2(2) imply

$$\begin{aligned}
 (6.8.5) \quad & \sum_{\mathbb{Z}[\alpha] = r} l(r) h(r) \sum_{g \in (T_A \cap C_A(\alpha, r)) // U} \overline{\chi(g)} \\
 &= \frac{1}{2} \sum_{0 < f \mid m} \phi(f) \prod_{p \mid N} \left\{ \sum_{\substack{\xi \in \Omega/p^{v+p} \\ g_\xi \in T_p}} \chi_p(\xi) + \sum_{\substack{\xi \in \Omega'/p^{v+p} \\ wg_\xi w^{-1} \in T_p}} \chi_p(t - \xi) \right\},
 \end{aligned}$$

where ϕ is the Euler function.

Take $T(n)$ for T , then we obtain by Lemma 5.2.5, (6.5.4), (6.5.6), and (6.8.5) that

$$\begin{aligned}
 (6.8.6) \quad & \sum_{\alpha \in T(n)^h // \Gamma} \overline{\chi(\alpha)} k(\alpha) l(\alpha) \\
 &= \frac{1}{2} \sum_{\substack{t \in \mathbb{Z} \\ t^2 - 4n = m^2 \neq 0}} \frac{\min\{|\eta|, |\zeta|\}^{k-1}}{|\eta - \zeta|} \text{sgn}(\eta)^k \\
 & \quad \times \sum_{0 < f|m} \phi(f) \prod_{p|N} \left\{ \sum_{\xi \in \Omega/p^{v+\rho}} \chi_p(\xi) + \sum_{\xi \in \Omega'/p^{v+\rho}} \chi_p(t - \xi) \right\}.
 \end{aligned}$$

Here η, ζ are the two roots of $X^2 - tX + n = 0$; $t^2 - 4n = m^2$ ($m > 0$); $\rho = \text{ord}_p(m/f)$; for p, t and f , Ω and Ω' are given by (6.8.3) and (6.8.4) with $d = 1$.

Now let α be an element of T^p , η a unique eigenvalue of α , and put $\varepsilon = \alpha - \eta$. Then $\varepsilon^2 = 0$, and $\mathbb{Q}[\alpha] = \mathbb{Q}[\varepsilon]$. Since η is a rational integer, we have $\mathbb{Z}[\alpha] = \mathbb{Z}[\varepsilon]$. Therefore any order of $\mathbb{Q}[\alpha]$ including $\mathbb{Z}[\alpha]$ is given by

$$r(l) = \mathbb{Z} + \frac{1}{l} \mathbb{Z} \varepsilon. \quad (l = 1, 2, \dots).$$

An easy calculation shows

$$|m(\alpha, r(l)^\times)| = l/|\eta|.$$

Thus by Theorem 6.7.2(3), (6.5.3) and (6.6.15), we get

$$\begin{aligned}
 (6.8.7) \quad & \sum_{\mathbb{Z}[\alpha] \subset r} l(r) h(r) \sum_{g \in (T_\alpha \cap C_\alpha(\alpha, r)) // U} \overline{\chi(g)} \\
 &= \frac{1}{2} \sum_{l=1}^{\infty} (|\eta|/l)^{s+1} \sum_{g \in (T_\alpha \cap C_\alpha(\alpha, r)) // U} \overline{\chi(g)} \\
 &= |\eta|^{s+1} \prod_{p \nmid N} (1 - p^{-(s+1)})^{-1} \\
 & \quad \times \prod_{p|N} \left[\sum_{\rho=0}^{\infty} p^{-\rho(s+1)} \left\{ \sum_{\substack{\xi \in \Omega/p^{v+\rho} \\ g_\xi \in T_p}} \chi_p(\xi) + \sum_{\substack{\xi \in \Omega'/p^{v+\rho} \\ wg_\xi w^{-1} \in T_p}} \chi_p(t - \xi) \right\} \right].
 \end{aligned}$$

Here $f_\alpha(X) = X^2 - tX + n$ is the principal polynomial of α ; η is a unique root of $f_\alpha(X) = 0$; and

$$(6.8.8) \quad \Omega = \Omega(\eta, \rho, p) = \{ \xi \in \mathbb{Z}_p \mid \xi \equiv \eta \pmod{p^{l(v+1)/2l + \rho}} \},$$

$$(6.8.9) \quad \Omega' = \Omega'(\eta, \rho, p) = \{ \xi \in \mathbb{Z}_p \mid \xi \equiv \eta \pmod{p^{l(v+1)/2l + \rho + 1}} \}.$$

Take $T(n)$ for T . If n is not square, then $T(n)^p = \emptyset$. Let $n = \eta^2$ ($\eta \in \mathbb{Z}$), and $m_\chi = \prod_p p^e$ be the conductor of χ . Then $e \leq v$, so that

$$(6.8.10) \quad \sum_{\substack{\xi \in \Omega/p^{v+\rho} \\ g_\xi \in T(n)_p}} \chi_p(\xi) = \begin{cases} 0, & \text{if } p|n, \text{ or } p \nmid n \text{ and } [(v+1)/2] + \rho < e, \\ \chi_p(\eta) p^{v - [(v+1)/2]}, & \text{otherwise,} \end{cases}$$

and

$$(6.8.11) \quad \sum_{\substack{\xi \in \Omega' / p^{v+\rho} \\ wg_\xi w^{-1} \in T(n)^p}} \chi_p(t - \xi) = \begin{cases} 0, & \text{if } p|n \text{ or } p \nmid n \text{ and } [v/2] + \rho + 1 < e, \\ \chi_p(\eta) p^{v - [v/2] - 1}, & \text{otherwise.} \end{cases}$$

Therefore by (6.5.6) and (6.8.7), we see that

$$(6.8.12) \quad \begin{aligned} & \sum_{\alpha \in T(n)^p // \Gamma} \overline{\chi(\alpha)} k(\alpha) l(\alpha) \\ &= \frac{S}{4} \zeta(s + 1) \sum_{\eta^2 = n} |\eta|^{s+1} \operatorname{sgn}(\eta)^k \chi(\eta) n^{k/2 - 1} \\ & \quad \times \prod_{p|N} (p^{v - [(v+1)/2] - \mu(s+1)} + p^{v - [v/2] - 1 - \mu'(s+1)}), \end{aligned}$$

where

$$\mu = \max\{0, e - [(v + 1)/2]\}, \quad \mu' = \max\{0, e - [v/2] - 1\}.$$

Hence we obtain

$$(6.8.13) \quad \begin{aligned} & \lim_{s \rightarrow 0} \sum_{\alpha \in T(n)^p // \Gamma} \overline{\chi(\alpha)} k(\alpha) l(\alpha) \\ &= \frac{1}{4} \sum_{\eta^2 = n} \operatorname{sgn}(\eta)^k \chi(\eta) n^{(k-1)/2} \prod_{p|N} (p^{v - [(v+1)/2] - \mu} + p^{v - [v/2] - 1 - \mu'}). \end{aligned}$$

The calculation of $\operatorname{tr}(T(n))$ is completed if we know the volume of $\Gamma \backslash \mathbf{H}$, which is given by the following

Theorem 6.8.3. *Let B be an indefinite quaternion algebra over \mathbb{Q} with discriminant d_B , and R an order of B of level N . Then*

$$v(\Gamma_R \backslash \mathbf{H}) = \frac{\pi}{3} N \prod_{p|N} (1 + p^{-1}) \prod_{p|d_B} (p - 1).$$

Proof. If R is maximal, then it is known that

$$(6.8.14) \quad v(\Gamma_R \backslash \mathbf{H}) = \frac{2\zeta(2)}{\pi} \prod_{p|d_B} (p - 1), \quad \zeta(2) = \pi^2/6.$$

(For the proof see [Shimizu 3]). We note that if $d_B = 1$, namely $B = M_2(\mathbb{Q})$, then (6.8.14) is nothing but Theorem 4.1.2(2). The result for arbitrary order follows from (6.8.14) and Lemma 5.3.2. □

We write down an explicit form of $\operatorname{tr}(T(n))$.

Theorem 6.8.4. *Let B be an indefinite quaternion algebra over \mathbb{Q} with discriminant d_B , R an order of B of level $N = \prod_p p^{v((d_B, N) = 1)}$, $\Gamma_R = \{\gamma \in R^\times \mid N_B(\gamma) = 1\}$,*

χ a Dirichlet character mod N , $m_\chi = \prod_p p^e$ the conductor of χ , and $T(n)$ the Hecke operator defined by (5.3.12). Then

$$\begin{aligned} \text{tr}(T(n)) &= \text{tr}(T(n)|\mathcal{S}_k(\Gamma_R, \chi)) \\ &= \chi(\sqrt{n}) \frac{k-1}{12} n^{k/2-1} N \prod_{p|N} (1+p^{-1}) \prod_{p|d_B} (p-1) \\ &\quad - \sum_t a(t) \sum_f b(t, f) c(t, f). \end{aligned}$$

Each term is as follows.

1° We understand $\chi(\sqrt{n}) = 0$ if n is not square.

2° t runs over all integers such that $t^2 - 4n$ are negative or square. For such a t , let ζ, η be two roots of $X^2 - tX + n = 0$, and put

$$d = \begin{cases} \text{the discriminant of } \mathbb{Q}(\sqrt{t^2 - 4n}), & \text{if } t^2 - 4n < 0, \\ 1 & \text{if } t^2 - 4n \text{ is a positive square,} \\ 0 & \text{if } t^2 - 4n = 0. \end{cases}$$

Then we put

$$a(t) = \begin{cases} 2^u \frac{\zeta^{k-1} - \eta^{k-1}}{\zeta - \eta}, & \text{if } d \neq 0, 1 \text{ and } \left(\frac{d}{p}\right) \neq 1 \text{ for any prime} \\ & \text{factor } p \text{ of } d_B, \\ \frac{1}{2} \frac{\min\{|\zeta|^{k-1}, |\eta|^{k-1}\}}{|\zeta - \eta|} \text{sgn}(\zeta)^k, & \text{if } d = 1, d_B = 1, \\ \frac{1}{4} \chi(t/2) \text{sgn}(t)^k n^{(k-1)/2}, & \text{if } d = 0, d_B = 1, \\ 0, & \text{otherwise } (d_B \neq 1 \text{ and either } d=0 \text{ or } 1), \end{cases}$$

where

$$u = \# \left\{ \text{prime numbers } p \mid p \mid d_B, \left(\frac{d}{p}\right) = -1 \right\}.$$

3° f runs over all positive divisors of m , where m is a positive integer given by $t^2 - 4n = m^2 d$ if $d \neq 0$; otherwise $m = 1$. For such an f ,

$$b(t, f) = \begin{cases} \frac{h(d)}{w(d)} f \prod_{p|f} \left(1 - \left(\frac{d}{p}\right) p^{-1}\right), & \text{if } d < 0, (f, d_B) = 1, \\ 0 & \text{if } d < 0, (f, d_B) \neq 1, \\ \phi(f), & \text{if } d = 1, \\ 1, & \text{if } d = 0, \end{cases}$$

where $h(d)$ is the class number of $\mathbb{Q}(\sqrt{d})$, and $w(d)$ the number of units in $\mathbb{Q}(\sqrt{d})$, namely

$$w(d) = \begin{cases} 4, & \text{if } d = -4, \\ 6, & \text{if } d = -3, \\ 2, & \text{otherwise,} \end{cases}$$

and ϕ is the Euler function.

4° For each prime factor p of N , and each positive divisor f of m , we put

$$\Omega = \Omega(t, f, p) = \{ \xi \in \mathbb{Z}_p \mid \xi^2 - t\xi + n \equiv 0 \pmod{(m/f)^2 N \mathbb{Z}_p} \},$$

$$\Omega' = \Omega'(t, f, p)$$

$$= \begin{cases} \{ \xi \in \mathbb{Z}_p \mid \xi^2 - t\xi + n \equiv 0 \pmod{p(m/f)^2 N \mathbb{Z}_p} \}, & \text{if } df \equiv 0 \pmod{p}, \\ \emptyset, & \text{otherwise.} \end{cases}$$

Then

$$c(t, f) = \begin{cases} 1, & \text{if } N = 1, \\ \prod_{p \mid N} \left\{ \sum_{\xi \in \Omega/p^{\nu+\rho}} \chi_p(\xi) + \sum_{\xi \in \Omega'/p^{\nu+\rho}} \chi_p(t - \xi) \right\}, & \text{if } d \neq 0, N > 1, \\ \prod_{p \mid N} (p^{\nu - [(\nu+1)/2] - \mu} + p^{\nu - [\nu/2] - 1 - \mu'}), & \text{if } d = 0, N > 1, \end{cases}$$

where

$$\begin{aligned} \rho &= \text{ord}_p(m/f), \\ \mu &= \max\{0, e - [(\nu+1)/2]\}, \\ \mu' &= \max\{0, e - [\nu/2] - 1\}, \end{aligned}$$

and χ_p is the character of $(\mathbb{Z}_p/N\mathbb{Z}_p)^\times$ induced from χ . We note that $\chi_p(a) = 0$ if $(a, N) \neq 1$ for $a \in \mathbb{Z}_p$ (even if χ_p is trivial).

Remark 6.8.1. Though we have assumed $k \geq 3$, a similar consideration using certain limit process is applicable to the case when $k = 2$ (see [Ishikawa]), but it needs the knowledge of infinite dimensional representation theory of $SL_2(\mathbb{R})$. Another method by Eichler enables us to calculate traces for the case when $k = 2$ ([Eichler 4], [Saito]). In any case, we can also calculate $\text{tr}(T(n))$ for the case when $k = 2$. We state the results without proof.

If χ is not trivial, then the above formula holds. Otherwise, $\text{tr}(T(n))$ is given by the above formula with the additional term

$$\delta(N, n) = \begin{cases} \prod_{p \mid n} \frac{1 - p^{l+1}}{1 - p} & (N = 1), \\ \prod_{p \mid n} p^l \prod_{\substack{p \mid n \\ p \nmid N}} \frac{1 - p^{l+1}}{1 - p}, & (N > 1), \end{cases}$$

where $n = \prod_p p^l$.

Remark 6.8.2. When $B = M_2(\mathbb{Q})$, we have $\Gamma_R = \Gamma_0(N)$, and $T(n)$ is the Hecke operator defined by (4.5.4).

Theorem 6.8.4 is still somewhat complicated to calculate in a general case. In many cases, we can still simplify it. As an example, we write down here, without proof, a computable formula for the special case when $\Gamma = \Gamma_0(N)$ with $N = pq^v$ (p, q : odd prime numbers, $v \geq 0$) and $(n, N) = 1$. Furthermore we assume that χ is induced by a Dirichlet character mod p and satisfies $\chi(-1) = (-1)^k$. Then

$$\begin{aligned} & \text{tr}(T(n)|\mathcal{S}_k(N, \chi)) \\ &= \chi(\sqrt{n}) \frac{k-1}{12} n^{(k-2)/2} (p+1) \times \begin{cases} 1 & (v=0), \\ q^{v-1}(q+1) & (v>0), \end{cases} \\ & - \chi(\sqrt{n}) n^{(k-1)/2} \times \begin{cases} 1 & (v=0), \\ q^{v/2} + q^{v/2-1} & (v: \text{even} > 0), \\ 2q^{(v-1)/2} & (v: \text{odd}), \end{cases} \\ & - \sum_{\substack{t|n \\ 0 < t < \sqrt{n}}} (\chi(t) + \chi(n/t)) t^{k-1} \times \begin{cases} 1 & (v=0), \\ q^{\lfloor v/2 \rfloor} + q^{t(v-1)/2} & (0 < v \leq 2\tau), \\ 2q^\tau & (2\tau < v), \end{cases} \\ & - \sum_{\substack{t \in \mathbb{Z} \\ t^2 - 4n < 0}} a_k(t) \sum_f b(t, f) c_p(t, f) \times \begin{cases} 1 & (v=0), \\ c_q(t, f) & (v>0), \end{cases} \\ & + \begin{cases} \delta(pq^v, n), & \text{if } k=2, \text{ and } \chi \text{ is trivial,} \\ 0, & \text{otherwise.} \end{cases} \end{aligned}$$

We explain each term. $\tau = \text{ord}_q(n/t - t)$. For each integer t satisfying $t^2 - 4n < 0$, $a_k(t)$ is given by

$$a_k(t) = \frac{\zeta^{k-1} - \eta^{k-1}}{\zeta - \eta},$$

where ζ and η are the roots of $X^2 - tX + n = 0$. For example,

$$\begin{aligned} a_2(t) &= 1, \quad a_3(t) = t, \quad a_4(t) = t^2 - n, \quad a_5(t) = t(t^2 - 2n), \\ a_6(t) &= t^4 - 3nt^2 + n^2, \dots, \\ a_{12}(t) &= t^{10} - 9nt^8 + 28n^2t^6 - 35n^3t^4 + 15n^4t^2 - n^5, \text{ etc.} \end{aligned}$$

The summation \sum_f is taken over all positive divisors f of m , where m is the positive integer given by

$$t^2 - 4n = m^2d$$

with the discriminant d of $\mathbb{Q}(\sqrt{t^2 - 4n})$; $c_p(t, f)$ is the p -component of $c(t, f)$, or

more explicitly,

$$c_p(t, f) = \begin{cases} \chi(\alpha) + \chi(\beta), & \text{if } p \nmid f, \left(\frac{d}{p}\right) = 1, \\ 0, & \text{if } p \nmid f, \left(\frac{d}{p}\right) = -1, \\ \chi(\alpha), & \text{if } p \nmid f, p \mid d, \\ 2\chi(\alpha), & \text{if } p \mid f, \end{cases}$$

where α and β are the roots of $X^2 - tX + n \equiv 0 \pmod p$. We note that if $p \nmid m$ and $\left(\frac{d}{p}\right) = 1$, then $X^2 - tX + n \equiv 0 \pmod p$ has two roots in $\mathbb{Z}/p\mathbb{Z}$ and if $p \mid dm$, then $X^2 - tX + n \equiv 0 \pmod p$ has a multiple root. Lastly $c_q(t, f)$ is given by the following table with $\mu = \text{ord}_q(df^2)$.

	$\mu = 0$	$0 < \mu < v$	$\mu = v$	$\mu > v$	
$c_q(t, f)$	2	$2(q^{\mu/2} + q^{\mu/2-1})$	$q^{v/2-1}(q+2)$	$q^{\lceil \frac{v}{2} \rceil} + q^{\lceil \frac{v-1}{2} \rceil}$	if $\left(\frac{d}{q}\right) = 1$
	0	0	$q^{\lceil \frac{v}{2} \rceil}$	$q^{\lceil \frac{v}{2} \rceil} + q^{\lceil \frac{v-1}{2} \rceil}$	if $\left(\frac{d}{q}\right) \neq 1$

We conclude this section by giving a method to calculate eigenvalues of Hecke operators. Let T be a linear transformation of an r -dimensional vector space over \mathbb{C} and a_1, \dots, a_r the eigenvalues of T . Put

$$\prod_{v=1}^r (X - a_v) = X^r - b_1 X^{r-1} + \dots + (-1)^r b_r.$$

Since b_μ is the μ -th symmetric function of a_1, \dots, a_r and

$$\text{tr}(T^\mu) = a_1^\mu + \dots + a_r^\mu,$$

we have only to calculate $\text{tr}(T^\mu)$ ($1 \leq \mu \leq r$) in order to get b_μ . Now apply the above argument to the case when $V = \mathcal{S}_k(N, \chi)$ and $T = T(n)$. Thus the calculation of the eigenvalues of the Hecke operator $T(n)$ is reduced to those of $\text{tr}(T(n)^\mu)$. Since $T(n)^\mu$ is a linear combination of $T(m)$ ($m \mid n^\mu$) by Lemma 4.5.7(2)

and Lemma 4.5.8(2), we have only to calculate $\text{tr}(T(m))$. In particular, for a prime number $n = p$, we easily obtain, for example,

$$b_1 = \text{tr}(T(p)),$$

$$b_2 = \{b_1^2 - \text{tr}(T(p^2)) + \chi(p)p^{k-1}r\}/2,$$

$$b_3 = \{\text{tr}(T(p^3)) + 2\chi(p)p^{k-1}b_1 - b_1^3 + b_1b_2\}/3, \text{ etc.}$$

Chapter 7. Eisenstein Series

We defined Eisenstein series as a special case of Poincaré series in §2.6 for weight $k \geq 3$. On the other hand, we also constructed the space of Eisenstein series by modular forms corresponding to products of two Dirichlet L -functions in §4.7. In this chapter, we further investigate Eisenstein series. Though the general arguments in §7.2 are applicable to any weight k , we explain in §7.1 the case of weight $k \geq 3$ separately, since that case is easy to handle because of the convergence of the series. In §7.2, we generalize the notion of Eisenstein series and define Eisenstein series with a complex parameter s . We calculate the Fourier expansions of these Eisenstein series and obtain the analytic continuation on parameter s following [Shimura 9, 12].

§7.1. Eisenstein Series of Weight $k \geq 3$

For modular groups, there are two types of Eisenstein series, though they essentially coincide. One is a series of which the summation is over cosets of a group, and the other is a series of which the summation is taken over elements of a lattice. The former is a special case of Poincaré series and was discussed in general in §2.6 for weight $k \geq 3$. As an example of the latter, we mention the Eisenstein series $E_k(z)$ for $SL_2(\mathbb{Z})$ in §4.1. Their relation is seen, for example, in (4.1.4). The former series appear in various applications of Eisenstein series, and the latter ones are easier for calculating Fourier expansions and are closely connected with Dirichlet L -functions. We shall begin with a generalization of $E_k(z)$.

Let χ and ψ be Dirichlet characters mod L and mod M , respectively. For any positive integer $k \geq 3$, we put

$$(7.1.1) \quad E_k(z; \chi, \psi) = \sum'_{m, n=-\infty}^{\infty} \chi(m)\psi(n)(mz+n)^{-k} \quad (z \in \mathbf{H}).$$

Here \sum' is the summation over all pairs of integers (m, n) except $(0, 0)$. We showed in the proof of Lemma 4.1.5 that there is a real valued continuous function $r(z)$ satisfying

$$(7.1.2) \quad \sum_{m, n=-\infty}^{\infty} |mz+n|^{-\sigma} \leq 8\zeta(\sigma-1)r(z)^{-\sigma} \quad (\sigma > 2).$$

Therefore the right-hand side of (7.1.1) is convergent absolutely and uniformly on any compact subset of \mathbf{H} . In particular, $E_k(z; \chi, \psi)$ is a holomorphic function on \mathbf{H} . We put

$$(7.1.3) \quad \Gamma_0(L, M) = \left\{ \begin{bmatrix} a & b \\ c & d \end{bmatrix} \in SL_2(\mathbb{Z}) \mid b \equiv 0 \pmod{M}, c \equiv 0 \pmod{L} \right\}.$$

Then $\Gamma_0(L, M)$ is a modular group.

Lemma 7.1.1. For $\gamma = \begin{bmatrix} a & b \\ c & d \end{bmatrix} \in \Gamma_0(L, M)$,

$$E_k(z; \chi, \psi)|_k \gamma = \chi(d) \bar{\psi}(d) E_k(z; \chi, \psi).$$

Proof. We put for integers m, n ,

$$m' = am + cn, \quad n' = bm + dn,$$

then

$$(7.1.4) \quad m(\gamma z) + n = (cz + d)^{-1} (m'z + n')$$

and

$$\chi(m') = \chi(a)\chi(m), \quad \psi(n') = \psi(d)\psi(n).$$

Therefore we see

$$(7.1.5) \quad \begin{aligned} \chi(m)\psi(n)(m(\gamma z) + n)^{-k} (cz + d)^{-k} \\ = \chi(d)\bar{\psi}(d)\chi(m')\psi(n')(m'z + n')^{-k}. \end{aligned}$$

When (m, n) runs over all pairs of integers except $(0, 0)$, so does (m', n') . Then we obtain the lemma by taking the summation of both sides of (7.1.5) on (m, n) and (m', n') . \square

Applying Lemma 7.1.1 to $\gamma = -1$, we obtain

$$(7.1.6) \quad \text{if } \chi(-1)\psi(-1) \neq (-1)^k, \text{ then } E_k(z; \chi, \psi) = 0.$$

Hereafter we assume

$$(7.1.7) \quad \chi(-1)\psi(-1) = (-1)^k.$$

We easily see the following

Lemma 7.1.2. $E_k(z; \chi, \psi)|_k \begin{bmatrix} 0 & -1 \\ 1 & 0 \end{bmatrix} = \chi(-1)E_k(z; \psi, \chi)$.

We are going to calculate Fourier expansions of $E_k(z; \chi, \psi)$. Since the right-hand side of (7.1.1) is absolutely convergent, we can exchange the order of summation. Thus

$$(7.1.8) \quad \begin{aligned} E_k(z; \chi, \psi) &= C + 2 \sum_{m=1}^{\infty} \chi(m) \sum_{n=-\infty}^{\infty} \psi(n)(mz + n)^{-k}, \\ C &= \begin{cases} 0 & (\chi \neq \chi_0), \\ 2L_M(k, \psi) & (\chi = \chi_0), \end{cases} \end{aligned}$$

where χ_0 is the principal character and $L_M(s, \psi)$ is the Dirichlet L -function. We rewrite (4.1.12) into

$$(7.1.9) \quad \sum_{n=-\infty}^{\infty} (z+n)^{-k} = \frac{(-2\pi i)^k}{(k-1)!} \sum_{n=1}^{\infty} n^{k-1} e^{2\pi i n z}.$$

Let m_ψ be the conductor of ψ , and ψ^0 the primitive character associated with ψ . Put $l=M/m_\psi$, then by Lemma 3.1.3,

$$(7.1.10) \quad \begin{aligned} & \sum_{n=-\infty}^{\infty} \psi(n)(mz+n)^{-k} \\ &= M^{-k} \sum_{a=0}^{M-1} \psi(a) \sum_{n=-\infty}^{\infty} \left(\frac{mz+a}{M} + n \right)^{-k} \\ &= \frac{(-2\pi i)^k}{M^k(k-1)!} \sum_{a=0}^{M-1} \psi(a) \sum_{n=1}^{\infty} n^{k-1} e^{2\pi i(mz+a)n/M} \\ &= \frac{(-2\pi i)^k}{M^k(k-1)!} \sum_{n=1}^{\infty} \left(\sum_{a=0}^{M-1} \psi(a)e^{2\pi i a n/M} \right) n^{k-1} e^{2\pi i m n z/M} \\ &= \frac{(-2\pi i)^k W(\psi^0)}{M^k(k-1)!} \sum_{n=1}^{\infty} b(n) n^{k-1} e^{2\pi i m n z/M}, \end{aligned}$$

where $W(\psi^0)$ is the Gauss sum of ψ^0 , and

$$(7.1.11) \quad b(n) = \sum_{0 < d|(l, n)} d\mu(l/d)\psi^0(l/d)\overline{\psi^0}(n/d)$$

with the Möbius function μ . Substituting (7.1.10) into (7.1.8), we obtain

Theorem 7.1.3. *Assume $k \geq 3$. Let χ and ψ be Dirichlet characters mod L and mod M , respectively, satisfying $\chi(-1)\psi(-1) = (-1)^k$. Let m_ψ be the conductor of ψ , and ψ^0 the primitive character associated with ψ . Then*

$$E_k(z; \chi, \psi) = C + A \sum_{n=1}^{\infty} a(n) e^{2\pi i n z/M},$$

where

$$\begin{aligned} A &= 2(-2\pi i)^k W(\psi^0)/M^k(k-1)!, \\ C &= \begin{cases} 2L_M(k, \psi) & (\chi: \text{the principal character}), \\ 0 & (\text{otherwise}), \end{cases} \end{aligned}$$

$$a(n) = \sum_{0 < c|n} \chi(n/c)c^{k-1} \sum_{0 < d|(l, c)} d\mu(l/d)\psi^0(l/d)\overline{\psi^0}(c/d).$$

Here $l=M/m_\psi$ and μ is the Möbius function. In particular, $E_k(z; \chi, \psi)$ is holomorphic at ∞ .

We observe that if ψ is primitive, then

$$(7.1.12) \quad a(n) = \sum_{0 < c|n} \chi(n/c)\overline{\psi}(c)c^{k-1}.$$

For a fixed $k \geq 3$, let $f(z; \chi, \psi)$ be the modular form defined in Theorem 4.7.1. Then for primitive characters χ and ψ , we have

$$(7.1.13) \quad E_k(Mz; \chi, \psi) = Af(z; \chi, \bar{\psi}), \quad A = 2(-2\pi i)^k W(\psi)/M^k(k-1)!$$

Now we are going to prove that $E_k(z; \chi, \psi)$ is also holomorphic at all cusps, and therefore it is an integral modular form. Let N be a positive integer. For two integers μ, ν such that $0 \leq \mu, \nu < N$, we put

$$(7.1.14) \quad E_k(z; \mu, \nu; N) = \sum'_{\substack{m \equiv \mu \pmod N \\ n \equiv \nu \pmod N}} (mz + n)^{-k}.$$

Here \sum' implies as usual that we omit $m = n = 0$ from the summation when $\mu = \nu = 0$.

Let $\gamma = \begin{bmatrix} a & b \\ c & d \end{bmatrix} \in SL_2(\mathbb{Z})$. If m and n are integers satisfying $m \equiv \mu \pmod N$ and $n \equiv \nu \pmod N$, then by (7.1.4) we have

$$(7.1.15) \quad m(\gamma z) + n = (cz + d)^{-1}(m'z + n')$$

and

$$m' = am + cn \equiv a\mu + c\nu \pmod N,$$

(7.1.16)

$$n' = bm + dn \equiv b\mu + d\nu \pmod N.$$

Therefore

$$(7.1.17) \quad E_k(z; \mu, \nu; N)|_k \gamma = E_k(z; \mu', \nu'; N) \quad (\gamma \in SL_2(\mathbb{Z})),$$

where μ', ν' are integers ($0 \leq \mu', \nu' < N$) given by

$$(7.1.18) \quad (\mu', \nu') \equiv (\mu, \nu)\gamma \pmod N.$$

In particular, if $\gamma \in \Gamma(N)$, then

$$E_k(z; \mu, \nu; N)|_k \gamma = E_k(z; \mu, \nu; N).$$

We also note that for a positive integer l ,

$$(7.1.19) \quad E_k(z; l\mu, l\nu; lN) = l^{-k} E_k(z; \mu, \nu; N).$$

Now we put

$$(7.1.20) \quad \mathcal{E}_k^{(1)}(\Gamma(N)) = \langle E_k(z; \mu, \nu; N) | 0 \leq \mu, \nu < N \rangle,$$

$$(7.1.21) \quad \mathcal{E}_k^{(2)}(\Gamma(N)) = \left\langle E_k\left(\frac{u}{v}z; \chi, \psi\right) \middle| \chi, \psi, u, v \right\rangle,$$

where χ, ψ, u, v in (7.1.21) are such that

(7.1.22) χ and ψ are Dirichlet characters mod L and mod M for divisors L and M of N , respectively;

(7.1.23) u and v are positive integers satisfying $uL|N$ and $vM|N$.

By (7.1.17) and (7.1.18),

$$(7.1.24) \quad \mathcal{E}_k^{(1)}(\Gamma(N)) \text{ is stable under the action of } SL_2(\mathbb{Z}).$$

Lemma 7.1.4. $\mathcal{E}_k^{(1)}(\Gamma(N)) = \mathcal{E}_k^{(2)}(\Gamma(N))$.

Proof. Let χ, ψ, u and v be as in (7.1.22) and (7.1.23). Then

$$\begin{aligned}
 (7.1.25) \quad E_k\left(\frac{u}{v}z; \chi, \psi\right) &= v^k \sum'_{m, n=-\infty}^{\infty} \chi(m)\psi(n)(muz + vn)^{-k} \\
 &= v^k \sum_{\substack{0 \leq \mu, v < N \\ u|\mu, v|v}} \chi(\mu/u)\psi(v/v) \sum'_{\substack{m \equiv \mu \pmod{N} \\ n \equiv v \pmod{N}}} (mz + n)^{-k} \\
 &= v^k \sum_{\substack{0 \leq \mu, v < N \\ u|\mu, v|v}} \chi(\mu/u)\psi(v/v)E_k(z; \mu, v; N).
 \end{aligned}$$

This implies that $\mathcal{E}_k^{(1)}(\Gamma(N)) \supset \mathcal{E}_k^{(2)}(\Gamma(N))$. Let μ, v be integers such that $0 \leq \mu, v < N$. Put $u = (\mu, N)$ and $v = (v, N)$. Further put $\mu' = \mu/u, v' = v/v, L = N/u$, and $M = N/v$. Then

$$\begin{aligned}
 (7.1.26) \quad E_k(z; \mu, v; N) &= \sum'_{\substack{m \equiv \mu' \pmod{L} \\ n \equiv v' \pmod{M}}} (muz + nv)^{-k} \\
 &= \{\phi(L)\phi(M)\}^{-1} \sum'_{m, n=-\infty}^{\infty} \sum_{\chi, \psi} \bar{\chi}(\mu')\bar{\psi}(v')\chi(m)\psi(n)(muz + nv)^{-k} \\
 &= \{\phi(L)\phi(M)\}^{-1} v^{-k} \sum_{\chi, \psi} \bar{\chi}(\mu')\bar{\psi}(v')E_k\left(\frac{u}{v}z; \chi, \psi\right),
 \end{aligned}$$

where $\sum_{\chi, \psi}$ implies the summation over all characters $\chi \pmod{L}$ and $\psi \pmod{M}$. This implies that $\mathcal{E}_k^{(1)}(\Gamma(N)) \subset \mathcal{E}_k^{(2)}(\Gamma(N))$. □

Lemma 7.1.5. $\mathcal{E}_k^{(1)}(\Gamma(N)) \subset \mathcal{G}_k(\Gamma(N))$.

Proof. By Theorem 7.1.3 and Lemma 7.1.4, all elements of $\mathcal{E}_k^{(1)}(\Gamma(N))$ are holomorphic at ∞ . Let $g(z)$ be an element of $\mathcal{E}_k^{(1)}(\Gamma(N))$. For any $\gamma \in SL_2(\mathbb{Z}), g|_k\gamma$ is holomorphic at ∞ , since $g|_k\gamma$ belongs to $\mathcal{E}_k^{(1)}(\Gamma(N))$ by (7.1.24). Therefore $g(z)$ is holomorphic at any cusp of $\Gamma(N)$. □

In particular, $E_k(z; \chi, \psi)$ is an integral form for any Dirichlet characters χ and ψ . We are going to prove that $\mathcal{E}_k^{(1)}(\Gamma(N))$ coincides with the space of Eisenstein series $\mathcal{N}_k(\Gamma(N))$ defined in §2.1. To prove this, we define Eisenstein series of Poincaré type. Let χ be a Dirichlet character mod N . We put

$$(7.1.27) \quad E_{k, N}^*(z; \chi) = \begin{cases} \sum_{\gamma \in \Gamma_\infty \setminus \Gamma} \chi(d)(cz + d)^{-k} & \text{if } \chi(-1) = (-1)^k, \\ 0 & \text{if } \chi(-1) \neq (-1)^k, \end{cases}$$

where $\Gamma = \Gamma_0(N)$ and $\gamma = \begin{bmatrix} * & * \\ c & d \end{bmatrix}$. This is nothing but the Poincaré series at ∞ defined in §2.6. More precisely, if $\chi(-1) = (-1)^k$, then

$$(7.1.28) \quad E_{k, N}^*(z; \chi) = F_k(z; \phi_0, \bar{\chi}, \Gamma_\infty, \Gamma)$$

with the constant function $\phi_0(z)=1$. Therefore $E_{k,N}^*(z; \chi)$ belongs to $\mathcal{N}_k(N, \bar{\chi})$ by Corollary 2.6.12. To express the summation of the right-hand side of (7.1.27) more explicitly, we need the following

Lemma 7.1.6. *The correspondence: $\begin{bmatrix} * & * \\ c & d \end{bmatrix} \mapsto (c, d)$ induces the following bijections:*

- (1) $\Gamma_0(N)_\infty \backslash \Gamma_0(N) \simeq \{(c, d) | c \equiv 0 \pmod N, (c, d) = 1, d > 0\}$;
- (2) $\Gamma(N)_\infty \backslash \Gamma(N) \simeq \begin{cases} \{(c, d) | c \equiv 0 \pmod N, d \equiv 1 \pmod N, (c, d) = 1\} \\ \hspace{15em} (N \geq 3), \\ \{(c, d) | c \equiv 0 \pmod N, d \equiv 1 \pmod N, (c, d) = 1, d > 0\} \\ \hspace{15em} (N = 1, 2). \end{cases}$

Proof. It is easy to see that the mapping is well-defined and surjective in both cases.

Let us prove the injectivity. Let $\gamma = \begin{bmatrix} a & b \\ c & d \end{bmatrix}$ and $\gamma' = \begin{bmatrix} a' & b' \\ c & d \end{bmatrix}$ be two elements of $\Gamma_0(N)$ (resp. $\Gamma(N)$) having the second row (c, d) in common. Then by a direct calculation, we see

$$\gamma\gamma'^{-1} = \begin{bmatrix} * & * \\ 0 & * \end{bmatrix},$$

which belongs to $\Gamma_0(N)_\infty$ (resp. $\Gamma(N)_\infty$). This implies the injectivity. □

This lemma implies that when $\chi(-1) = (-1)^k$,

$$E_{k,N}^*(z; \chi) = \sum_{\substack{c \equiv 0 \pmod N \\ (c, d) = 1, d > 0}} \chi(d)(cz + d)^{-k},$$

and therefore, for any Dirichlet character $\chi \pmod N$, we obtain

$$(7.1.29) \quad E_{k,N}^*(z; \chi) = \frac{1}{2} \sum_{\substack{c \equiv 0 \pmod N \\ (c, d) = 1}} \chi(d)(cz + d)^{-k}.$$

Thus

$$(7.1.30) \quad E_k(Nz; \chi_0, \chi) = 2L_N(k, \chi)E_{k,N}^*(z; \chi)$$

for the principal character χ_0 , and

$$(7.1.31) \quad E_k(z; 0, 1; N) = \frac{2}{\phi(N)} \sum_{\chi} L_N(k, \chi)E_{k,N}^*(z; \chi)$$

by (7.1.26), where χ runs over all characters mod N . Since $E_{k,N}^*(z; \chi)$ belongs to $\mathcal{N}_k(\Gamma(N))$ by Theorem 2.1.7(2), we see

$$(7.1.32) \quad E_k(z; 0, 1; N) \in \mathcal{N}_k(\Gamma(N)).$$

Theorem 7.1.7. *If $k \geq 3$, then*

$$\mathcal{N}_k(\Gamma(N)) = \mathcal{E}_k^{(1)}(\Gamma(N)).$$

Proof. We see by (7.1.17) and (7.1.19) that $\mathcal{E}_k^{(1)}(\Gamma(N))$ is generated by

$$\{E_k(z; 0, 1; L)|_k \gamma \mid L|N, \gamma \in SL_2(\mathbb{Z})\}.$$

Since

$$E_k(z; 0, 1; L) \in \mathcal{N}_k(\Gamma(L)) \subset \mathcal{N}_k(\Gamma(N)),$$

we see $\mathcal{E}_k^{(1)}(\Gamma(N)) \subset \mathcal{N}_k(\Gamma(N))$. Let us prove $\mathcal{N}_k(\Gamma(N)) \subset \mathcal{E}_k^{(1)}(\Gamma(N))$. First by Lemma 7.1.6(2) and (7.1.29), we see

$$\begin{aligned} (7.1.33) \quad F_k(z; \phi_0, \chi_0, \Gamma(N)_\infty, \Gamma(N)) &= C \sum_{\substack{c \equiv 0 \pmod N \\ d \equiv 1 \pmod N \\ (c, d) = 1}} (cz + d)^{-k} \\ &= \frac{2C}{\phi(N)} \sum_{\chi} E_{k, N}^*(z; \chi), \end{aligned}$$

where

$$C = \begin{cases} 1 & (N \geq 3), \\ 2 & (N = 1, 2), \end{cases}$$

and χ runs over all Dirichlet characters mod N . Since $E_{k, N}^*(z; \chi)$ belongs to $\mathcal{E}_k^{(1)}(\Gamma(N))$ by (7.1.30) and Lemma 7.1.4, so does $F_k(z; \phi_0, \chi_0, \Gamma(N)_\infty, \Gamma(N))$. Since $\mathcal{E}_k^{(1)}(\Gamma(N))$ is stable under $SL_2(\mathbb{Z})$, we see

$$F_k(z; \phi_0, \chi_0, \Gamma(N)_\infty, \Gamma(N))|_k \gamma \in \mathcal{E}_k^{(1)}(\Gamma(N)) \quad \text{for } \gamma \in SL_2(\mathbb{Z}).$$

By (2.6.11) and Corollary 2.6.12, we obtain $\mathcal{N}_k(\Gamma(N)) \subset \mathcal{E}_k^{(1)}(\Gamma(N))$. □

§ 7.2. Analytic Continuation of Eisenstein Series

When k is smaller than 3, the right-hand side of (7.1.1) is not convergent. Therefore we need some modification to discuss the case when $k \leq 2$. Though the main object is the case when $k \leq 2$, we note that the arguments and the results here cover any integral weight k .

Now for any integer k and a complex number s , we put

$$(7.2.1) \quad E_k(z, s; \chi, \psi) = \sum'_{m, n = -\infty}^{\infty} \chi(m)\psi(n)(mz + n)^{-k} |mz + n|^{-2s}.$$

The right-hand side is uniformly and absolutely convergent for s on $k + 2\text{Re}(s) \geq 2 + \varepsilon$ ($\varepsilon > 0$). Therefore it is holomorphic on $k + 2\text{Re}(s) > 2$. We call $E_k(z, s; \chi, \psi)$ an *Eisenstein series with parameter s* . Similarly to Lemma 7.1.1, we obtain that

$$(7.2.2) \quad E_k(\gamma z, s; \chi, \psi) = \chi(d)\bar{\psi}(d)(cz + d)^k |cz + d|^{2s} E_k(z, s; \chi, \psi)$$

$$\gamma = \begin{bmatrix} a & b \\ c & d \end{bmatrix} \in \Gamma_0(L, M).$$

As was mentioned above, if $k \leq 2$, then the right-hand side of (7.2.1) is not defined for $s = 0$. But if $E_k(z, s; \chi, \psi)$ is continued analytically to $s = 0$ and holomorphic at $s = 0$, then we will obtain a modular form even for weight $k = 1$ and 2. The purpose of this section is the investigation of the analytic continuation of $E_k(z, s; \chi, \psi)$ and its property as a function of z and s . Since we easily see that

$$\text{if } \chi(-1)\psi(-1) \neq (-1)^k, \text{ then } E_k(z, s; \chi, \psi) = 0,$$

we assume

$$(7.2.3) \quad \chi(-1)\psi(-1) = (-1)^k$$

throughout this section. We also see

$$(7.2.4) \quad E_k(z, s; \chi, \psi) = \chi(-1)E_{-k}(-\bar{z}, k+s; \chi, \psi) \quad \text{if } k+2\text{Re}(s) > 2.$$

When $k+2\text{Re}(s) > 2$, we can exchange the order of summation of the right-hand side of (7.2.1) and see

$$(7.2.5) \quad E_k(z, s; \chi, \psi) = C(s) + 2 \sum_{m=1}^{\infty} \chi(m) \sum_{n=-\infty}^{\infty} \psi(n)(mz+n)^{-k} |mz+n|^{-2s},$$

where

$$(7.2.6) \quad C(s) = \begin{cases} 0 & (\chi \neq \chi_0), \\ 2L_M(k+2s, \psi) & (\chi = \chi_0). \end{cases}$$

For complex numbers α and β , we put

$$(7.2.7) \quad S(z; \alpha, \beta) = \sum_{n=-\infty}^{\infty} (z+n)^{-\alpha} (\bar{z}+n)^{-\beta} \quad (z \in \mathbf{H}).$$

The right-hand side is absolutely convergent for α, β with $\text{Re}(\alpha + \beta) > 1$, and

$$(7.2.8) \quad \begin{aligned} & \sum_{n=-\infty}^{\infty} \psi(n)(mz+n)^{-k} |mz+n|^{-2s} \\ &= (mM)^{-(k+2s)} \sum_{a=0}^{mM-1} \psi(a) S\left(\frac{z}{M} + \frac{a}{mM}; k+s, s\right). \end{aligned}$$

Further we put

$$(7.2.9) \quad \phi(y; \alpha, \beta; x) = (x+iy)^{-\alpha} (x-iy)^{-\beta} \quad (x \in \mathbb{R}, y > 0, \alpha, \beta \in \mathbb{C}).$$

If we write $z = x + iy$ ($\in \mathbf{H}$), then

$$(7.2.10) \quad S(z; \alpha, \beta) = \sum_{n=-\infty}^{\infty} \phi(y; \alpha, \beta; x+n).$$

We wish to apply the Poisson summation formula to the right-hand side. When $\text{Re}(\alpha + \beta) > 1$, $\phi(y; \alpha, \beta; x)$ belongs to $L^1(\mathbb{R})$ as a function of x . Therefore there exists the Fourier transform of ϕ , which we denote by $\xi(y; \alpha, \beta; t)$. In other words,

$$(7.2.11) \quad \xi(y; \alpha, \beta; t) = \int_{\mathbb{R}} \phi(y; \alpha, \beta; x) e^{-2\pi itx} dx \quad (y > 0, \text{Re}(\alpha + \beta) > 1).$$

This is a holomorphic function of α and β on the domain

$$\{(\alpha, \beta) \in \mathbb{C} \times \mathbb{C} \mid \operatorname{Re}(\alpha + \beta) > 1\},$$

since the right-hand side is uniformly convergent on any compact subset of the domain. Now the Poisson summation formula implies

$$(7.2.12) \quad \sum_{n=-\infty}^{\infty} \phi(y; \alpha, \beta; x + n) = \sum_{n=-\infty}^{\infty} e^{2\pi i n x} \xi(y; \alpha, \beta; n).$$

To justify this formula, it is sufficient to verify the following two conditions:

$$(7.2.13) \quad \sum_{n=-\infty}^{\infty} |\phi(y; \alpha, \beta; x + n)| \text{ is uniformly convergent for } x;$$

$$(7.2.14) \quad \sum_{n=-\infty}^{\infty} |\xi(y; \alpha, \beta; n)| \text{ is convergent.}$$

When $\operatorname{Re}(\alpha + \beta) > 1$, (7.2.13) is obvious and (7.2.14) will be shown in Theorem 7.2.8 below. Keeping it in mind, we are going to investigate the function ξ . We put

$$(7.2.15) \quad \mathbf{H}' = \{z \in \mathbb{C} \mid \operatorname{Re}(z) > 0\}$$

and call it the *right half plane*. If $z_1, z_2 \in \mathbf{H}'$, then

$$(z_1 z_2)^\alpha = z_1^\alpha z_2^\alpha \quad (\alpha \in \mathbb{C})$$

by definition (see (3.2.1)). We define the *confluent hypergeometric function* $\sigma(z; \alpha, \beta)$ by

$$(7.2.16) \quad \sigma(z; \alpha, \beta) = \int_0^\infty e^{-zu} (u + 1)^{\alpha-1} u^{\beta-1} du \quad (z, \beta \in \mathbf{H}', \alpha \in \mathbb{C})$$

and put

$$(7.2.17) \quad \eta(y; \alpha, \beta; t) = \int_{|t|}^\infty e^{-yu} (u + t)^{\alpha-1} (u - t)^{\beta-1} du$$

$(y > 0, t \in \mathbb{R}, \alpha, \beta \in \mathbb{C}).$

We see easily the following properties:

$$(7.2.18) \quad \text{if } \eta(y; \alpha, \beta; t) \text{ is convergent, then so is } \eta(y; \beta, \alpha; -t) \text{ and}$$

$$\eta(y; \alpha, \beta; t) = \eta(y; \beta, \alpha; -t);$$

$$(7.2.19) \quad \text{if } a > 0 \text{ and } \eta(ay; \alpha, \beta; t) \text{ is convergent, then so is } \eta(y; \alpha, \beta; at) \text{ and}$$

$$\eta(ay; \alpha, \beta; t) = a^{1-\alpha-\beta} \eta(y; \alpha, \beta; at).$$

As for the convergence of the functions η and σ , we obtain the following

Lemma 7.2.1. (1) *If $t > 0$, then $\eta(y; \alpha, \beta; t)$ is uniformly convergent on any compact subset of $\mathbb{C} \times \mathbf{H}'$ as a function of α and β .*

(2) *The function $\sigma(z; \alpha, \beta)$ is uniformly convergent on any compact subset of $\mathbf{H}' \times \mathbb{C} \times \mathbf{H}'$.*

(3) If $(y, \alpha, \beta) \in \mathbb{R}_+ \times \mathbb{C} \times \mathbf{H}'$, then

$$\eta(y; \alpha, \beta; 1) = e^{-y} 2^{\alpha+\beta-1} \sigma(2y; \alpha, \beta).$$

Proof. First we prove (2). Let T be an arbitrary compact subset of $\mathbf{H}' \times \mathbb{C} \times \mathbf{H}'$. Put

$$p = \min \{ \operatorname{Re}(z) \mid (z, \alpha, \beta) \in T \},$$

$$q = \min \{ \operatorname{Re}(\beta) \mid (z, \alpha, \beta) \in T \}.$$

Let p' be a number satisfying $0 < p' < p$, then there exist constants C_1 and C_2 satisfying

$$|e^{-zu}(u+1)^{\alpha-1}u^{\beta-1}| = \begin{cases} O(e^{-p'u}) & (u \rightarrow \infty), \\ O(u^{q-1}) & (u \rightarrow +0), \end{cases}$$

for any point $(z, \alpha, \beta) \in T$. This implies $\int_0^\infty |e^{-zu}(u+1)^{\alpha-1}u^{\beta-1}| du$ is uniformly convergent on T . The first assertion is similarly proved. Let us show (3). If $(y, \alpha, \beta) \in \mathbb{R}_+ \times \mathbb{C} \times \mathbf{H}'$, then

$$\begin{aligned} \eta(y; \alpha, \beta; 1) &= \int_1^\infty e^{-yu}(u+1)^{\alpha-1}(u-1)^{\beta-1} du \\ &= \int_0^\infty e^{-y(u+1)}(u+2)^{\alpha-1}u^{\beta-1} du \\ &= e^{-y} 2^{\alpha+\beta-1} \sigma(2y; \alpha, \beta). \end{aligned}$$

This implies (3). □

Lemma 7.2.2. If $\operatorname{Re}(\alpha) > 0, \operatorname{Re}(\beta) > 1$ ($t \geq 0$) or $\operatorname{Re}(\alpha) > 1, \operatorname{Re}(\beta) > 0$ ($t < 0$), then

$$\xi(y; \alpha, \beta; t) = i^{\beta-\alpha} (2\pi) \Gamma(\alpha)^{-1} \Gamma(\beta)^{-1} \eta(2y; \alpha, \beta, \pi t).$$

Proof. We note that $\xi(y; \alpha, \beta; t)$ is holomorphic for α, β with $\operatorname{Re}(\alpha + \beta) > 1$. Now we see

$$\begin{aligned} \xi(y; \alpha, \beta; t) &= \int_{-\infty}^\infty e^{-2\pi itx} (x+iy)^{-\alpha} (x-iy)^{-\beta} dx \\ &= \int_{-\infty}^\infty e^{-2\pi itx} (i(y-ix))^{-\alpha} (-i(y+ix))^{-\beta} dx. \end{aligned}$$

Since $y \pm ix \in \mathbf{H}'$, we see easily

$$(i(y \pm ix))^{-\alpha} = i^{-\alpha} (y \pm ix)^{-\alpha}.$$

Therefore

$$(7.2.20) \quad \xi(y; \alpha, \beta; t) = i^{\beta-\alpha} \int_{-\infty}^\infty e^{-2\pi itx} (y-ix)^{-\alpha} (y+ix)^{-\beta} dx.$$

Assume that $\operatorname{Re}(\alpha) > 0$ and $\operatorname{Re}(\beta) > 1$. We put $s = \alpha, a = y \pm ix$ in (3.2.5), then

$$(7.2.21) \quad (y \pm ix)^{-\alpha} = \Gamma(\alpha)^{-1} \int_0^\infty e^{-(y \pm ix)u} u^{\alpha-1} du.$$

Substituting this into (7.2.20), we see

$$(7.2.22) \quad \begin{aligned} \xi(y; \alpha, \beta; t) &= i^{\beta-\alpha} \Gamma(\alpha)^{-1} \int_{-\infty}^{\infty} e^{-2\pi i t x} (y+ix)^{-\beta} dx \int_0^{\infty} e^{-(y-ix)u} u^{\alpha-1} du \\ & \quad (\operatorname{Re}(\alpha) > 0, \operatorname{Re}(\beta) > 1). \end{aligned}$$

Since the right-hand side is absolutely convergent, we can exchange the order of integration and obtain

$$(7.2.23) \quad = i^{\beta-\alpha} \Gamma(\alpha)^{-1} \int_0^{\infty} e^{-uy} u^{\alpha-1} du \int_{-\infty}^{\infty} e^{ix(u-2\pi t)} (y+ix)^{-\beta} dx.$$

If we put $f(x) = (y+ix)^{-\beta}$, then $f(x) \in L^1(\mathbb{R})$. Let \hat{f} be the Fourier transform of f . Then

$$(7.2.24) \quad \int_{-\infty}^{\infty} e^{ix(u-2\pi t)} f(x) dx = \hat{f}\left(\frac{2\pi t-u}{2\pi}\right).$$

To calculate \hat{f} , we put

$$(7.2.25) \quad g(u) = \begin{cases} e^{-yu} u^{\beta-1} & (u > 0), \\ 0 & (u \leq 0). \end{cases}$$

Since $\operatorname{Re}(\beta) > 1$, we have $g(u) \in L^1(\mathbb{R})$. If we denote by \hat{g} the Fourier transform of g , then we see by (7.2.21)

$$f(x) = \Gamma(\beta)^{-1} \hat{g}(x/2\pi).$$

Taking the Fourier transform of both sides, we see

$$(7.2.26) \quad \hat{f}(u) = 2\pi \Gamma(\beta)^{-1} g(-2\pi u).$$

By (7.2.24), (7.2.25), and (7.2.26), we obtain

$$(7.2.27) \quad \begin{aligned} & \int_{-\infty}^{\infty} e^{ix(u-2\pi t)} (y+ix)^{-\beta} dx \\ &= \begin{cases} 2\pi \Gamma(\beta)^{-1} e^{-y(u-2\pi t)} (u-2\pi t)^{\beta-1} & (u > 2\pi t), \\ 0 & (u \leq 2\pi t). \end{cases} \end{aligned}$$

Now we assume $t \geq 0$. Then by (7.2.23) and (7.2.27), we see for $\operatorname{Re}(\alpha) > 0$, $\operatorname{Re}(\beta) > 1$,

$$(7.2.28) \quad \begin{aligned} \xi(y; \alpha, \beta; t) &= i^{\beta-\alpha} \cdot 2\pi \Gamma(\alpha)^{-1} \Gamma(\beta)^{-1} \int_{u > 2\pi t} e^{-2y(u-\pi t)} u^{\alpha-1} (u-2\pi t)^{\beta-1} du \\ &= i^{\beta-\alpha} \cdot 2\pi \Gamma(\alpha)^{-1} \Gamma(\beta)^{-1} \int_{\pi t}^{\infty} e^{-2yu} (u+\pi t)^{\alpha-1} (u-\pi t)^{\beta-1} du \\ &= i^{\beta-\alpha} \cdot 2\pi \Gamma(\alpha)^{-1} \Gamma(\beta)^{-1} \eta(2y; \alpha, \beta; \pi t). \end{aligned}$$

We note that if $t > 0$ then $\xi(y; \alpha, \beta; t)$ is continued to a holomorphic function of α

and β on $\mathbb{C} \times \mathbf{H}'$ by (7.2.28) and Lemma 7.2.1(1). If $t < 0$, then

$$(7.2.29) \quad \xi(y; \alpha, \beta; t) = (-1)^{\beta-\alpha} \xi(y; \beta, \alpha; |t|)$$

as long as $\operatorname{Re}(\alpha + \beta) > 1$ by definition. Therefore if we define $\xi(y; \alpha, \beta; t)$ for $(\alpha, \beta) \in \mathbf{H}' \times \mathbb{C}$ by (7.2.29), it is a meromorphic function and

$$(7.2.30) \quad \begin{aligned} \xi(y; \alpha, \beta; t) &= (-1)^{\beta-\alpha} i^{\alpha-\beta} \cdot 2\pi\Gamma(\alpha)^{-1} \Gamma(\beta)^{-1} \eta(2y; \beta, \alpha; |\pi t|) \\ &= i^{\beta-\alpha} \cdot 2\pi\Gamma(\alpha)^{-1} \Gamma(\beta)^{-1} \eta(2y; \alpha, \beta; \pi t). \end{aligned}$$

Therefore the case when $t < 0$ is also proved. □

When $t = 0$, ξ is explicitly calculated in the following

Lemma 7.2.3. *The function $\xi(y; \alpha, \beta; 0)$ is continued analytically to a meromorphic function on $\mathbb{C} \times \mathbb{C}$ and satisfies*

$$\xi(y; \alpha, \beta; 0) = i^{\beta-\alpha} \cdot 2\pi\Gamma(\alpha)^{-1} \Gamma(\beta)^{-1} \Gamma(\alpha + \beta - 1)(2y)^{1-\alpha-\beta}.$$

Proof. When $\operatorname{Re}(\alpha + \beta) > 1$, we see

$$\begin{aligned} \eta(y; \alpha, \beta; 0) &= \int_0^\infty e^{-yu} u^{\alpha+\beta-2} du \\ &= \Gamma(\alpha + \beta - 1) y^{1-\alpha-\beta}. \end{aligned}$$

Since the right-hand side is a meromorphic function on $\mathbb{C} \times \mathbb{C}$, we obtain the analytic continuation of the function by Lemma 7.2.2. □

We shall calculate $\xi(y; \alpha, \beta; t)$ for $t \neq 0$. The calculation of $\xi(y; \alpha, \beta; t)$ is reduced to that of $\eta(y; \alpha, \beta; 1)$ by Lemma 7.2.2, (7.2.18) and (7.2.19). Furthermore by Lemma 7.2.1(3), we have only to consider $\sigma(z; \alpha, \beta)$. Now we put

$$(7.2.31) \quad \omega(z; \alpha, \beta) = \Gamma(\beta)^{-1} z^\beta \sigma(z; \alpha, \beta) \quad ((z, \alpha, \beta) \in \mathbf{H}' \times \mathbb{C} \times \mathbf{H}').$$

By Lemma 7.2.1(2), $\omega(z; \alpha, \beta)$ is a holomorphic function on $\mathbf{H}' \times \mathbb{C} \times \mathbf{H}'$.

Theorem 7.2.4. *The function $\omega(z; \alpha, \beta)$ is continued analytically to a holomorphic function on $\mathbf{H}' \times \mathbb{C} \times \mathbb{C}$ and satisfies:*

- (1) $\omega(z; 1 - \beta, 1 - \alpha) = \omega(z; \alpha, \beta)$;
- (2) $\omega(z; \alpha, \beta) = (-1)^n e^z z^\beta \frac{\partial^n}{\partial z^n} (e^{-z} z^{-\beta} \omega(z; \alpha - n, \beta)) \quad (n \in \mathbb{N})$.

Proof. For $\alpha, \beta \in \mathbf{H}'$ and $z \in \mathbb{R}_+$, we see

$$(7.2.32) \quad \Gamma(\beta)\sigma(z; 1 - \beta, \alpha) = \int_0^\infty e^{-zu} \Gamma(\beta)(u + 1)^{-\beta} u^{\alpha-1} du.$$

Since

$$\Gamma(\beta)(u + 1)^{-\beta} = \int_0^\infty e^{-v(u+1)} v^{\beta-1} dv,$$

we have

$$(7.2.33) \quad \Gamma(\beta)\sigma(z; 1 - \beta, \alpha) = \int_0^\infty e^{-zu} u^{\alpha-1} du \int_0^\infty e^{-v(u+1)} v^{\beta-1} dv.$$

The integral is absolutely convergent, so that we can exchange the order of integration, and therefore,

$$\begin{aligned} &= \int_0^\infty e^{-v} v^{\beta-1} dv \int_0^\infty e^{-u(z+v)} u^{\alpha-1} du \\ &= \Gamma(\alpha) \int_0^\infty e^{-v} (z+v)^{-\alpha} v^{\beta-1} dv \\ &= \Gamma(\alpha) z^{\beta-\alpha} \sigma(z; 1 - \alpha, \beta). \end{aligned}$$

Since $\Gamma(\beta)\sigma(z; 1 - \beta, \alpha)$ and $\Gamma(\alpha)z^{\beta-\alpha}\sigma(z; 1 - \alpha, \beta)$ are holomorphic on $\mathbf{H}' \times \mathbf{H}' \times \mathbf{H}'$, they coincide with each other there.

Thus we obtain

$$(7.2.34) \quad \omega(z; 1 - \beta, 1 - \alpha) = \omega(z; \alpha, \beta) \quad (z \in \mathbf{H}', \operatorname{Re}(\alpha) < 1, \operatorname{Re}(\beta) > 0).$$

Define $\omega(z; \alpha, \beta)$ for $\alpha \in \mathbb{C}$ with $\operatorname{Re}(\alpha) < 1$ and $\beta \in \mathbb{C}$ by the left-hand side of (7.2.34). Then it is a holomorphic function on $\mathbf{H}' \times \{\alpha \mid \operatorname{Re}(\alpha) < 1\} \times \mathbb{C}$, which coincides with the original $\omega(z; \alpha, \beta)$ when $\operatorname{Re}(\beta) > 0$. Now when $(z, \alpha, \beta) \in \mathbf{H}' \times \mathbf{H}' \times \mathbf{H}'$, the integral of the right-hand side of (7.2.16) is uniformly convergent with respect to z on any compact subset of \mathbf{H}' . Therefore we obtain

$$(7.2.35) \quad \frac{\partial^n}{\partial z^n} (e^{-z} \sigma(z; \alpha, \beta)) = (-1)^n e^{-z} \sigma(z; \alpha + n, \beta) \quad ((z, \alpha, \beta) \in \mathbf{H}' \times \mathbf{H}' \times \mathbf{H}'),$$

so that the continued function $\omega(z; \alpha, \beta)$ also satisfies

$$(7.2.36) \quad \frac{\partial^n}{\partial z^n} (e^{-z} z^{-\beta} \omega(z; \alpha, \beta)) = (-1)^n e^{-z} z^{-\beta} \omega(z; \alpha + n, \beta) \quad ((z, \alpha, \beta) \in \mathbf{H}' \times \{\alpha \mid \operatorname{Re}(\alpha) < 1\} \times \mathbb{C}).$$

For any $(z, \alpha, \beta) \in \mathbf{H}' \times \mathbb{C} \times \mathbb{C}$, take a positive integer n so that $\operatorname{Re}(\alpha) < n + 1$ and define $\omega(z; \alpha, \beta)$ by

$$(7.2.37) \quad \omega(z; \alpha, \beta) = (-1)^n e^z z^\beta \frac{\partial^n}{\partial z^n} (e^{-z} z^{-\beta} \omega(z; \alpha - n, \beta)),$$

then ω is a holomorphic function on $\mathbf{H}' \times \mathbb{C} \times \mathbb{C}$. □

Now we have

Theorem 7.2.5. (1) For each $y > 0$, as a function of α and β , $\xi(y; \alpha, \beta; t)$ is analytically continued to a meromorphic function on $\mathbb{C} \times \mathbb{C}$ which is expressed as

$$\xi(y; \alpha, \beta; t) = \begin{cases} i^{\beta-\alpha}(2\pi)^\alpha \Gamma(\alpha)^{-1} (2y)^{-\beta} t^{\alpha-1} e^{-2\pi y t} \omega(4\pi y t; \alpha, \beta) & (t > 0), \\ i^{\beta-\alpha}(2\pi)^{\alpha+\beta} \Gamma(\alpha)^{-1} \Gamma(\beta)^{-1} \Gamma(\alpha + \beta - 1) (4\pi y)^{1-\alpha-\beta} & (t = 0), \\ i^{\beta-\alpha}(2\pi)^\beta \Gamma(\beta)^{-1} (2y)^{-\alpha} |t|^{\beta-1} e^{-2\pi y |t|} \omega(4\pi y |t|; \beta, \alpha) & (t < 0). \end{cases}$$

(2) As a function of α and β , $\xi(y; \alpha, \beta; t)$ is holomorphic on $\mathbb{C} \times \mathbb{C}$ for $t \neq 0$, and $\Gamma(\alpha + \beta - 1)^{-1} \xi(y; \alpha, \beta; 0)$ is holomorphic on $\mathbb{C} \times \mathbb{C}$.

Proof. The expression of $\xi(y; \alpha, \beta; t)$ in (1) is straightforward from Lemma 7.2.1, Lemma 7.2.2, Lemma 7.2.3, (7.2.18), (7.2.19) and (7.2.31) on a certain subdomain. Since the right-hand side is meromorphic on $\mathbb{C} \times \mathbb{C}$ in each case, we obtain the analytic continuation. The second assertion is obvious from this expression and Lemma 7.2.4. □

Lemma 7.2.6. For $(z, \alpha) \in \mathbb{H}' \times \mathbb{C}$, we have

$$\omega(z; \alpha, 0) = 1.$$

Proof. If $\text{Re}(\alpha) > 0$, then Lemma 7.2.4 and (7.2.31) imply that

$$\begin{aligned} \omega(z; 1 - \alpha, 0) &= \omega(z; 1, \alpha) \\ &= \Gamma(\alpha)^{-1} z^\alpha \sigma(z; 1, \alpha) \\ &= \Gamma(\alpha)^{-1} z^\alpha \int_0^\infty e^{-zu} u^{\alpha-1} du \\ &= 1. \end{aligned}$$

Since $\omega(z; \alpha, 0)$ is holomorphic on α , we get the assertion. □

Theorem 7.2.7. For any compact subset T of $\mathbb{C} \times \mathbb{C}$, there exist positive numbers A and B satisfying

$$|\omega(y; \alpha, \beta)| \leq A(1 + y^{-B}) \quad ((y, \alpha, \beta) \in \mathbb{R}_+ \times T).$$

Proof. First we prove the assertion when T is contained in $\mathbb{C} \times \mathbb{H}'$. Take a positive integer n so that $\text{Re}(\alpha) \leq n + 1$ for any $(\alpha, \beta) \in T$. Let (α, β) be any point in T . Since $\text{Re}(\beta) > 0$, we see by (7.2.16) and (7.2.31) that

$$\begin{aligned} |\omega(y; \alpha, \beta)| &\leq |\Gamma(\beta)|^{-1} y^{\text{Re}(\beta)} \int_0^\infty e^{-yu} (u + 1)^n u^{\text{Re}(\beta)-1} du \\ &= |\Gamma(\beta)|^{-1} \sum_{k=0}^n \binom{n}{k} \Gamma(k + \text{Re}(\beta)) y^{-k}. \end{aligned}$$

Since $\Gamma(k + \text{Re}(\beta))$ and $|\Gamma(\beta)|^{-1}$ are continuous functions of β , there exists a positive constant A_1 satisfying

$$|\omega(y; \alpha, \beta)| \leq A_1 \sum_{k=0}^n y^{-k} \leq A_1 n(1 + y^{-n}) \quad ((\alpha, \beta) \in T).$$

Therefore putting $A = A_1 n$ and $B = n$, we obtain the assertion. Next we have to remove the assumption on T . If $\beta \in \mathbf{H}'$, then taking integration by parts of the right-hand side of (7.2.16), we have

$$(7.2.38) \quad \sigma(y; \alpha, \beta + 1) = y^{-1}(\alpha - 1)\sigma(y; \alpha - 1, \beta + 1) + y^{-1}\beta\sigma(y; \alpha, \beta).$$

Multiplying $y^{\beta+1}\Gamma(\beta + 1)^{-1}$ to both sides, we obtain

$$(7.2.39) \quad \omega(y; \alpha, \beta) = \omega(y; \alpha, \beta + 1) + (1 - \alpha)y^{-1}\omega(y; \alpha - 1, \beta + 1),$$

$$((\alpha, \beta) \in \mathbb{C} \times \mathbf{H}').$$

Since both sides of (7.2.39) are holomorphic functions of α and β , (7.2.39) holds on $\mathbb{C} \times \mathbb{C}$. Using (7.2.39) repeatedly, we obtain

$$(7.2.40) \quad \omega(y; \alpha, \beta) = \sum_{k=0}^m \binom{m}{k} y^{-k} (1 - \alpha)(2 - \alpha) \cdots (k - \alpha)\omega(y; \alpha - k, \beta + m).$$

For any compact subset T of $\mathbb{C} \times \mathbb{C}$, we take a positive integer m so that

$$\{(\alpha, \beta + m) \mid (\alpha, \beta) \in T\} \subset \mathbb{C} \times \mathbf{H}'.$$

Then we see easily the existence of the desired constants A and B from the result when T is contained in $\mathbb{C} \times \mathbf{H}'$. □

Now we can justify the Poisson summation formula and prove (7.2.12).

Theorem 7.2.8. *Let $S(z; \alpha, \beta)$ be the function defined in (7.2.7). Then it is analytically continued to a meromorphic function on $\mathbb{C} \times \mathbb{C}$ with respect to (α, β) , and is expressed as*

$$(7.2.41) \quad S(z; \alpha, \beta) = \xi(y; \alpha, \beta; 0) + \sum_{\substack{m=-\infty \\ m \neq 0}}^{\infty} e^{2\pi i m x} \xi(y; \alpha, \beta; m) \quad (z = x + iy \in \mathbf{H}).$$

The series $\sum_{\substack{m=-\infty \\ m \neq 0}}^{\infty} e^{2\pi i m x} \xi(y; \alpha, \beta; m)$ is convergent uniformly and absolutely on any compact subset of $\mathbf{H} \times \mathbb{C} \times \mathbb{C}$. Further $\Gamma(\alpha + \beta - 1)^{-1}S(z; \alpha, \beta)$ is an entire function of α and β .

Proof. Let T be a compact subset of $\mathbf{H} \times \mathbb{C} \times \mathbb{C}$. By Theorem 7.2.5, there exist positive constants C_1, p and q such that

$$(7.2.42) \quad |\xi(y; \alpha, \beta; m)| \leq C_1 m^p e^{-2\pi q m} |\omega(4\pi y m; \alpha, \beta)|$$

for any point $(z, \alpha, \beta) \in T$ and any positive integer m . We also see by Theorem 7.2.7 the existence of a positive constant C_2 satisfying

$$|\omega(4\pi y m; \alpha, \beta)| < C_2$$

for any $(z, \alpha, \beta) \in T$ and any positive integer m . Therefore we have

$$(7.2.43) \quad \sum_{m=1}^{\infty} |e^{2\pi i m x} \xi(y; \alpha, \beta; m)| \leq C_1 C_2 \sum_{m=1}^{\infty} m^p e^{-2\pi q m}.$$

Since the right-hand side is clearly convergent, the left-hand side is uniformly convergent on T . We can also similarly prove that $\sum_{m=-\infty}^{-1} |e^{2\pi imx} \xi(y; \alpha, \beta; m)|$ is uniformly convergent on T . Hence (7.2.14) is verified for α and β with $\text{Re}(\alpha + \beta) > 1$. Therefore the Poisson summation formula is applicable, and (7.2.10) and (7.2.12) imply that (7.2.41) holds for α and β with $\text{Re}(\alpha + \beta) > 1$. Since $\sum_{m=1}^{\infty} e^{2\pi imx} \xi(y; \alpha, \beta; m)$ and $\sum_{m=-\infty}^{-1} e^{2\pi imx} \xi(y; \alpha, \beta; m)$ are holomorphic on α and β , and $\xi(y; \alpha, \beta; 0)$ is meromorphic, the right-hand side of (7.2.41) is a meromorphic function on $\mathbb{C} \times \mathbb{C}$ and its poles coincide with those of $\xi(y; \alpha, \beta; 0)$. Therefore if we define $S(z; \alpha, \beta)$ on $\mathbf{H} \times \mathbb{C} \times \mathbb{C}$ by the right-hand side of (7.2.41), we obtain the assertion by Theorem 7.2.5(2). \square

Now by (7.2.5), (7.2.8) and Theorem 7.2.8, we obtain

$$\begin{aligned}
 (7.2.44) \quad E_k(z, s; \chi, \psi) &= C(s) + 2M^{-k-2s} \sum_{m=1}^{\infty} \chi(m) m^{-k-2s} \sum_{a=0}^{mM-1} \psi(a) S\left(\frac{z}{M} + \frac{a}{mM}; k+s, s\right) \\
 &= C(s) + 2M^{-k-2s} \sum_{m=1}^{\infty} \chi(m) m^{-k-2s} \sum_{a=0}^{mM-1} \psi(a) \sum_{n=-\infty}^{\infty} e^{2\pi i n(mx+a)/mM} \\
 &\qquad \qquad \qquad \times \xi\left(\frac{y}{M}; k+s, s; n\right)
 \end{aligned}$$

for s with $k + 2\text{Re}(s) > 2$, where $C(s)$ is the function given by (7.2.6). If we put $\sigma = \text{Re}(s)$, then

$$\begin{aligned}
 &\sum_{m=1}^{\infty} m^{-k-2\sigma} \sum_{a=0}^{mM-1} \sum_{n=-\infty}^{\infty} \left| \xi\left(\frac{y}{M}; k+s, s; n\right) \right| \\
 &\leq A \left(\sum_{m=1}^{\infty} m^{-k-2\sigma+1} \right) \left(\left| \xi\left(\frac{y}{M}; k+s, s; 0\right) \right| + B \sum_{n=1}^{\infty} n^p e^{-2\pi qn} \right)
 \end{aligned}$$

with some positive constants A, B, p and q . Therefore the right-hand side is absolutely convergent if $k + 2\text{Re}(s) > 2$. Therefore we can exchange the order of summation of the right-hand side of (7.2.44) and obtain

$$\begin{aligned}
 (7.2.45) \quad E_k(z, s; \chi, \psi) &= C(s) + 2M^{-k-2s} \sum_{n=-\infty}^{\infty} \alpha(n, s; \chi, \psi) e^{2\pi inx/M} \xi\left(\frac{y}{M}; k+s, s; n\right),
 \end{aligned}$$

where

$$\alpha(n, s; \chi, \psi) = \sum_{m=1}^{\infty} \chi(m) m^{-k-2s} \sum_{a=0}^{mM-1} \psi(a) e^{2\pi ina/mM}.$$

Now by Lemma 3.1.3(1), we have

$$(7.2.46) \quad \sum_{a=0}^{mM-1} \psi(a) e^{2\pi ina/mM} = \begin{cases} m \sum_{a=0}^{M-1} \psi(a) e^{2\pi ian/mM} & \text{if } m|n, \\ 0 & \text{if } m \nmid n. \end{cases}$$

Let ψ^0 be the primitive character associated with ψ of conductor $m_\psi = M/l$. Lemma 3.1.3(2) and (7.2.46) imply that for $n > 0$,

$$\begin{aligned}
 (7.2.47) \quad \alpha(n, s; \chi, \psi) &= \sum_{0 < m|n} \chi(m) m^{-k-2s+1} \sum_{a=0}^{M-1} \psi(a) e^{2\pi i a n / m M} \\
 &= n^{-k-2s+1} W(\psi^0) \sum_{0 < c|n} \chi(n/c) c^{k+2s-1} \sum_{0 < d|(l, c)} d\mu(l/d) \psi^0(l/d) \overline{\psi^0}(c/d),
 \end{aligned}$$

where μ is the Möbius function. We also see for $-n < 0$,

$$\begin{aligned}
 (7.2.48) \quad \alpha(-n, s; \chi, \psi) &= n^{-k-2s+1} \psi(-1) W(\psi^0) \sum_{0 < c|n} \chi(n/c) c^{k+2s-1} \\
 &\quad \times \sum_{0 < d|(l, c)} d\mu(l/d) \psi^0(l/d) \overline{\psi^0}(c/d).
 \end{aligned}$$

Lastly (7.2.46) implies that

$$(7.2.49) \quad \alpha(0, s; \chi, \psi) = \begin{cases} \phi(M) \sum_{m=1}^{\infty} \chi(m) m^{-k-2s+1} & (\psi: \text{the trivial} \\ & \text{character mod } M), \\ 0 & (\text{otherwise}), \end{cases}$$

where ϕ is the Euler function. Substituting (7.2.47), (7.2.48), (7.2.49) into (7.2.45), we obtain the following

Theorem 7.2.9. *Let χ and ψ be Dirichlet characters mod L and mod M , respectively, satisfying $\chi(-1)\psi(-1) = (-1)^k$. Then for any integer k , the Eisenstein series $E_k(z, s; \chi, \psi)$ is analytically continued to a meromorphic function on the whole s -plane and has the Fourier expansion*

$$\begin{aligned}
 E_k(z, s; \chi, \psi) &= C(s) + D(s) y^{1-k-2s} \\
 &\quad + A(s) y^{-s} \sum_{n=1}^{\infty} a_n(s) n^{-s} e^{2\pi i n z / M} \omega(4\pi y n / M; k + s, s) \\
 &\quad + B(s) y^{-k-s} \sum_{n=1}^{\infty} a_n(s) n^{-s-k} e^{-2\pi i n \bar{z} / M} \omega(4\pi y n / M; s, k + s),
 \end{aligned}$$

where

$$C(s) = \begin{cases} 0 & (\chi \neq \chi_0), \\ 2L_M(2s + k, \psi) & (\chi = \chi_0), \end{cases}$$

$$D(s) = \begin{cases} 2\sqrt{\pi} i^{-k} \prod_{p|M} (1 - p^{-1}) \Gamma(s)^{-1} \Gamma(s + k)^{-1} \\ \quad \times \Gamma\left(\frac{2s + k - 1}{2}\right) \Gamma\left(\frac{2s + k}{2}\right) L_L(2s + k - 1, \chi) & (\psi: \text{the trivial character mod } M), \\ 0 & (\text{otherwise}), \end{cases}$$

$$\begin{aligned}
 A(s) &= 2^{k+1} i^{-k} W(\psi^0)(\pi/M)^{s+k} \Gamma(s+k)^{-1}, \\
 B(s) &= 2^{1-k} i^{-k} \psi(-1) W(\psi^0)(\pi/M)^s \Gamma(s)^{-1}, \\
 a_n(s) &= \sum_{0 < c|n} \chi(n/c) c^{k+2s-1} \sum_{0 < d|(l,c)} d \mu(l/d) \psi^0(l/d) \overline{\psi^0}(c/d).
 \end{aligned}$$

Here ψ^0 is the primitive character associated with ψ of conductor $m_\psi = M/l$; μ is the Möbius function; $\omega(z; \alpha, \beta)$ is the holomorphic function on $\mathbf{H}' \times \mathbb{C} \times \mathbb{C}$ defined by (7.2.31). Moreover two series on the right-hand side are convergent uniformly and absolutely with respect to s on any compact subset of \mathbb{C} .

Proof. First let us calculate each term. Assume that $n = 0$ and ψ is the trivial character mod M . Then by (7.2.49), Theorem 7.2.5, and (3.2.6),

$$\begin{aligned}
 &2M^{-k-2s} \alpha(0, s; \chi, \psi) \xi(y/M; s+k, s; 0) \\
 &= 2^{3-k-2s} \frac{\phi(M)}{M} i^{-k} \pi \Gamma(s)^{-1} \Gamma(s+k)^{-1} \Gamma(2s+k-1) L_L(2s+k-1, \chi) y^{1-k-2s} \\
 &= 2\sqrt{\pi} i^{-k} \prod_{p|M} (1-p^{-1}) \Gamma(s)^{-1} \Gamma(s+k)^{-1} \\
 &\quad \times \Gamma\left(\frac{2s+k-1}{2}\right) \Gamma\left(\frac{2s+k}{2}\right) L_L(2s+k-1, \chi) y^{1-k-2s}.
 \end{aligned}$$

The terms for $n \neq 0$ are calculated similarly by (7.2.47), (7.2.48), and Theorem 7.2.5. We shall prove the convergence of the series. Let K be any compact subset of \mathbb{C} . Then by Theorem 7.2.7, there exist positive constants A and B satisfying

$$|\omega(4\pi ny/M; k+s, s)| \leq A(1+y^{-B})$$

for any positive integer n and any $s \in K$. We also see easily the existence of the constant u satisfying $|a_n(s)| \leq n^u$ for any $s \in K$. Then the two series are convergent uniformly and absolutely on K , and therefore, they are entire functions of s . \square

Corollary 7.2.10. (1) If ψ is non-trivial, then $E_k(z, s; \chi, \psi)$ is an entire function of s .

(2) Assume ψ is trivial. If $k \geq 1$, then $E_k(z, s; \chi, \psi)$ is holomorphic for $\text{Re}(s) > (1-k)/2$. When $k = 1$, $E_1(z, s; \chi, \psi)$ is holomorphic for $\text{Re}(s) > -1/2$.

(3) If both χ and ψ are trivial, then $E_0(z, s; \chi, \psi)$ is holomorphic for $\text{Re}(s) > 1$ and has a simple pole at $s = 1$ with residue $\frac{\pi}{y} \prod_{p|L} \left(1 - \frac{1}{p}\right) \prod_{p|M} \left(1 - \frac{1}{p}\right)$.

Proof. The first assertion is straightforward from Theorem 7.2.9, Corollary 3.3.2 and (3.3.5). If $k > 0$, then we easily see that both $C(s)$ and $D(s)$ are holomorphic for $\text{Re}(s) > (1-k)/2$ by Theorem 3.2.2(2). If $k = 1$ and ψ is trivial, then χ is non-trivial. Then $C(s) = 0$ and $D(s)$ is holomorphic for $\text{Re}(s) > -1/2$ by Corollary 3.3.2. Next assume that $k = 0$, and χ and ψ are trivial. Then it is easy to see that $C(s)$ and $D(s)$ are holomorphic for $\text{Re}(s) > 1$. The residue at $s = 1$ is also obtained by Theorem 3.2.2(2). \square

Corollary 7.2.11. *Put*

$$E_k(s) = \begin{cases} \Gamma(s+k)E_k(z, s; \chi, \psi) & (k \geq 0), \\ \Gamma(s)E_k(z, s; \chi, \psi) & (k < 0). \end{cases}$$

Then $E_k(s)$ is an entire function except for the case where $k=0$ and χ, ψ are trivial. Moreover when $k=0$ and χ, ψ are trivial,

(1) if either χ or ψ is not principal, then $E_k(s)$ is holomorphic on the whole s -plane except for a simple pole at $s = 1$;

(2) if both χ and ψ are principal, then $E_k(s)$ is holomorphic on the whole s -plane except for simple poles at $s = 0$ and $s = 1$.

Proof. We shall prove our assertions only for $k \geq 0$, since the argument for $k < 0$ is quite similar. First of all, we see that both

$$\Gamma(s+k)A(s) = 2^{1+k}i^{-k}W(\psi^0)(\pi/M)^{s+k}$$

and

$$\Gamma(s+k)B(s) = 2^{1-k}i^{-k}\psi(-1)W(\psi^0)(\pi/M)^s s(s+1) \cdots (s+k-1)$$

are entire functions. Now we shall study the behavior of $\Gamma(s+k)(C(s) + D(s)y^{1-k-2s})$. First consider $\Gamma(s+k)C(s)$. If $\chi \neq \chi_0$, then $C(s) = 0$. Otherwise, we see

$$\Gamma(s+k)C(s) = \frac{2\Gamma(s+k)}{\Gamma((2s+k+\delta)/2)} \cdot \Gamma((2s+k+\delta)/2)L_M(2s+k, \psi),$$

where $\delta = \delta_\psi$. Since $\psi(-1) = (-1)^k$, we see that $k + \delta \equiv 0 \pmod{2}$, and therefore $\Gamma(s+k)\Gamma((2s+k+\delta)/2)^{-1}$ is entire. If ψ is non-trivial, then $\Gamma(s+k)C(s)$ is entire since $\Gamma((2s+k+\delta)/2)L_M(2s+k, \psi)$ is entire by Corollary 3.3.2. Assume that ψ is the trivial character mod M . If $k > 0$, then $\Gamma(s+k)C(s)$ is holomorphic except for a simple pole at $s = (1-k)/2$ with residue

$$\Gamma((1+k)/2) \prod_{p|M} (1-p^{-1}).$$

If $k = 0$, then $\Gamma(s+k)C(s)$ is holomorphic except for simple poles at $s = 0$ and $s = 1/2$ and the residue at $s = 1/2$ is

$$\Gamma(1/2) \prod_{p|M} (1-p^{-1}).$$

Next we consider $\Gamma(s+k)D(s)$. If ψ is non-trivial, then $D(s) = 0$. If ψ is the trivial character mod M , then

$$\begin{aligned} & \Gamma(s+k)D(s)y^{1-k-2s} \\ &= 2\sqrt{\pi}i^{-k} \prod_{p|M} (1-p^{-1})y^{1-k-2s}\Gamma(s)^{-1}\Gamma\left(\frac{2s+k-1}{2}\right)\Gamma\left(\frac{2s+k}{2}\right)L_L(2s+k-1, \chi) \\ &= 2\sqrt{\pi}i^{-k} \prod_{p|M} (1-p^{-1})y^{1-k-2s} \end{aligned}$$

$$\times \begin{cases} \frac{\Gamma\left(s + \frac{k-1}{2}\right)}{\Gamma(s)} \Gamma\left(\frac{2s+k}{2}\right) L_L(2s+k-1, \chi) & (k: \text{odd}), \\ \frac{\Gamma\left(s + \frac{k}{2}\right)}{\Gamma(s)} \Gamma\left(\frac{2s+k-1}{2}\right) L_L(2s+k-1, \chi) & (k: \text{even}). \end{cases}$$

This implies that if χ is non-trivial, then $\Gamma(s+k)D(s)y^{1-k-2s}$ is entire by Corollary 3.3.2. Assume that χ is trivial and $L \neq 1$. Then k is even and $\Gamma((2s+k-1)/2)\zeta(2s+k-1)$ is holomorphic except for simple poles at $s = (1-k)/2$ and $s = 1-k/2$. Then we see

$$\begin{aligned} & \frac{\Gamma\left(s + \frac{k}{2}\right)}{\Gamma(s)} \Gamma\left(\frac{2s+k-1}{2}\right) L_L(2s+k-1, \chi) \\ &= s(s+1) \dots \left(s + \frac{k}{2} - 1\right) \Gamma\left(\frac{2s+k-1}{2}\right) \zeta(2s+k-1) \prod_{p|L} (1 - p^{1-k-2s}) \end{aligned}$$

and it is entire if $k > 0$, or it is holomorphic except for a simple pole at $s = 1$ if $k = 0$. Assume $\chi = \chi_0$. If $k > 0$, then $\Gamma(s+k)D(s)y^{1-k-2s}$ is holomorphic except for a simple pole at $s = (1-k)/2$ with residue

$$\begin{aligned} & 2\sqrt{\pi}(-1)^{k/2} \Gamma((1-k)/2)^{-1} \Gamma(1/2) \prod_{p|M} (1 - p^{-1}) \zeta(0) \\ &= -\Gamma((1+k)/2) \prod_{p|M} (1 - p^{-1}) \end{aligned}$$

by (3.2.4). If $k = 0$, then $\Gamma(s+k)D(s)y^{1-k-2s}$ is holomorphic except for simple poles at $s = 1/2$ and $s = 1$, and the residue at $s = 1/2$ is

$$-\sqrt{\pi} \prod_{p|M} (1 - p^{-1}).$$

This completes the proof. □

If $k \geq 3$, then we see that

$$E_k(z, 0; \chi, \psi) = E_k(z; \chi, \psi)$$

and the Fourier expansion in Theorem 7.2.9 with $s=0$ is nothing but that of $E_k(z; \chi, \psi)$ obtained in Theorem 7.1.3 by Lemma 7.2.6.

Now let us consider the cases when $k = 1, 2$. Since $E_k(z, s; \chi, \psi)$ is holomorphic at $s = 0$ by Corollary 7.2.10, we put

$$(7.2.50) \quad E_k(z; \chi, \psi) = E_k(z, 0; \chi, \psi),$$

and

$$(7.2.51) \quad E_2(z) = E_2(z; \chi_0, \chi_0)$$

with the principal character χ_0 .

Theorem 7.2.12. *If χ and ψ are Dirichlet characters mod L and mod M , respectively, satisfying $\chi\psi(-1) = 1$, then*

$$E_2(z; \chi, \psi) = C + Dy^{-1} + A \sum_{n=1}^{\infty} a_n e^{2\pi inz/M}.$$

Here

$$C = \begin{cases} 0 & (\chi \neq \chi_0), \\ 2L_M(2, \psi) & (\chi = \chi_0), \end{cases}$$

$$D = \begin{cases} -\pi \prod_{p|M} (1-p^{-1}) \prod_{p|L} (1-p^{-1}) & (\chi, \psi: \text{trivial}), \\ 0 & (\text{otherwise}), \end{cases}$$

$$A = -8\pi^2 W(\psi^0)/M^2,$$

$$a_n = \sum_{0 < c|n} \chi(n/c)c \sum_{0 < d|(l,c)} d\mu(l/d)\psi^0(l/d)\overline{\psi^0}(c/d),$$

where ψ^0, l, μ are as in Theorem 7.2.9.

Theorem 7.2.13. *If χ and ψ are Dirichlet characters mod L and mod M , respectively, satisfying $\chi\psi(-1) = -1$, then*

$$E_1(z; \chi, \psi) = C + D + A \sum_{n=1}^{\infty} a_n e^{2\pi inz/M}.$$

Here

$$C = \begin{cases} 0 & (\chi \neq \chi_0), \\ 2L_M(1, \psi) & (\chi = \chi_0), \end{cases}$$

$$D = \begin{cases} 0 & (\psi: \text{non-trivial}), \\ -2\pi i \prod_{p|M} (1-p^{-1})L_L(0, \chi) & (\psi: \text{trivial}), \end{cases}$$

$$A = -4\pi i W(\psi^0)/M,$$

$$a_n = \sum_{0 < c|n} \chi(n/c) \sum_{0 < d|(l,c)} d\mu(l/d)\psi^0(l/d)\overline{\psi^0}(c/d),$$

where ψ^0, l, μ are as in Theorem 7.2.9.

Corollary 7.2.14. *Assume $k > 0$. Then $E_k(z; \chi, \psi)$ is a holomorphic function of z on \mathbf{H} except for the case when $k = 2$ and both χ and ψ are trivial. Further $E_2(z) - pE_2(pz)$ is holomorphic on \mathbf{H} for any prime number p .*

Proof. We have only to verify the assertion when $k = 1$ and $k = 2$. Let a_n be as in Theorem 7.2.12 (if $k = 2$) or in Theorem 7.2.13 (if $k = 1$). Then $a_n = O(n^k)$. Thus $\sum_{n=1}^{\infty} a_n e^{2\pi inz/M}$ is convergent uniformly on $\{z \in \mathbf{H} | \text{Im}(z) > c\}$ with any positive constant c . Therefore it is holomorphic on \mathbf{H} . Since the coefficient of y^{-1} in $E_2(z) - pE_2(pz)$ vanishes, we see the second assertion. \square

Let N be a positive integer. For integers μ, ν such that $0 \leq \mu, \nu < N$, we put

$$(7.2.52) \quad E_k(z, s; \mu, \nu; N) = \sum'_{\substack{m+n \equiv \mu \pmod N \\ n \equiv \nu \pmod N}} (mz + n)^{-k} |mz + n|^{-2s}.$$

Here \sum' implies that we omit $m = n = 0$ from the summation when $\mu = \nu = 0$. We also put

$$(7.2.53) \quad \tilde{\mathcal{E}}_k^{(1)}(\Gamma(N)) = \langle E_k(z, s; \mu, \nu; N) \mid 0 \leq \mu, \nu < N \rangle,$$

$$(7.2.54) \quad \tilde{\mathcal{E}}_k^{(2)}(\Gamma(N)) = \left\langle E_k\left(\frac{u}{v}z, s; \chi, \psi\right) \middle| \chi, \psi, u, v \right\rangle,$$

where χ, ψ, u , and v in (7.2.54) are those satisfying (7.1.22) and (7.1.23). For any element $g(z, s)$ of $\tilde{\mathcal{E}}_k^{(1)}(\Gamma(N))$ and $\tilde{\mathcal{E}}_k^{(2)}(\Gamma(N))$, we put

$$(7.2.55) \quad (g|_{k,s}\gamma)(z) = g(\gamma z, s)j(\gamma, z)^{-k} |j(\gamma, z)|^{-2s}, \quad \gamma \in SL_2(\mathbb{Z}).$$

We see that

$$(7.2.56) \quad \tilde{\mathcal{E}}_k^{(1)}(\Gamma(N)) \text{ is stable under the action of } SL_2(\mathbb{Z}).$$

Now we have

Theorem 7.2.15. (1) $\tilde{\mathcal{E}}_k^{(1)}(\Gamma(N)) = \tilde{\mathcal{E}}_k^{(2)}(\Gamma(N))$.

(2) Let $g(z, s) \in \tilde{\mathcal{E}}_k^{(1)}(\Gamma(N))$. If $g(z, s)$ is holomorphic on a compact subset T of the s -plane, then there exists a constant c such that

$$g(z, s) = O(y^c) \quad (z = x + iy), \quad (y \rightarrow \infty)$$

uniformly on $x \in \mathbb{R}$ and $s \in T$.

Proof. The first assertion is proved by a similar argument to that in Lemma 7.1.4. The latter is proved by Theorem 7.2.7, Theorem 7.2.9, (7.2.56) and (1). \square

By the above theorem, if $k > 0$, then $E_k(z, s; \mu, \nu; N)$ is holomorphic at $s = 0$. For $k > 0$, we put

$$(7.2.57) \quad E_k(z; \mu, \nu; N) = E_k(z, 0; \mu, \nu; N),$$

and

$$(7.2.58) \quad \mathcal{E}_k^{(1)}(\Gamma(N)) = \langle E_k(z; \mu, \nu; N) \mid 0 \leq \mu, \nu < N \rangle,$$

$$(7.2.59) \quad \mathcal{E}_k^{(2)}(\Gamma(N)) = \left\langle E_k\left(\frac{u}{v}z; \chi, \psi\right) \middle| \chi, \psi, u, v \right\rangle,$$

where χ, ψ, u , and v are as in (7.2.54). If $k > 2$, then these definitions coincide with those in §7.1.

Theorem 7.2.16. Let k be a positive integer. Then

(1) $\mathcal{E}_k^{(1)}(\Gamma(N)) = \mathcal{E}_k^{(2)}(\Gamma(N))$.

(2) If $f(z) \in \mathcal{E}_k^{(1)}(\Gamma(N))$ is holomorphic, then it belongs to $\mathcal{G}_k(\Gamma(N))$. In particular

$\mathcal{E}_k^{(1)}(\Gamma(N)) \subset \mathcal{G}_k(F(N))$ if $k \neq 2$.

(3) $E_2(Nz, 0; \chi, \psi) \in \mathcal{G}_2(\Gamma(N))$ if ψ is not trivial. Moreover if $g(z) \in \mathcal{E}_2^{(1)}(\Gamma(N))$, then there exists a constant c such that $g(z) - cE_2(z) \in \mathcal{G}_2(\Gamma(N))$.

Proof. When $k > 2$, we have already proved the assertions in §7.1. The first assertion for general k is straightforward from Theorem 7.2.15(1). We also see easily that $\mathcal{E}_k^{(1)}(\Gamma(N))$ is stable under the action of $SL_2(\mathbb{Z})$. Let $f(z)$ be an element of $\mathcal{E}_k^{(1)}(\Gamma(N))$. If $f(z)$ is holomorphic on \mathbf{H} , then it is also holomorphic at ∞ by (1) and Theorem 7.2.9. Let x be a cusp of $\Gamma(N)$ and take $\gamma \in SL_2(\mathbb{Z})$ so that $\gamma\infty = x$. Since $f|_k\gamma$ belongs to $\mathcal{E}_k^{(2)}(\Gamma(N))$, it is also holomorphic at ∞ . This implies that $f(z)$ is holomorphic at x and (2) is proved. The first part of (3) is obvious. Now let $g(z)$ be an element of $\mathcal{E}_2^{(1)}(\Gamma(N))$. Then by (1) and Theorem 7.2.12, we see

$$g(z) = c_0 + \frac{c_1}{y} + \text{a power series of } e^{2\pi iz/N}.$$

Then there exists a constant c such that $g(z) - cE_2(z)$ is holomorphic on \mathbf{H} and is also holomorphic at ∞ . Let x be a cusp of $\Gamma(N)$ and take $\gamma \in SL_2(\mathbb{Z})$ so that $\gamma\infty = x$. Then since $(g - cE_2)|_2\gamma$ belongs to $\mathcal{E}_2^{(2)}(\Gamma(N))$,

$$(g - cE_2)|_2\gamma = c'_0 + \frac{c'_1}{y} + \text{a power series of } e^{2\pi iz/N}.$$

Since $(g - cE_2)|_2\gamma$ is holomorphic on \mathbf{H} , we see $c'_1 = 0$. This implies that $g - cE_2$ is also holomorphic at x . □

For a Dirichlet character $\chi \pmod N$, we define

$$(7.2.60) \quad E_{k,N}^*(z, s; \chi) = \begin{cases} \sum_{\gamma \in R} \chi(d)j(\gamma, z)^{-k}|j(\gamma, z)|^{-2s} & (\chi(-1) = (-1)^k, \gamma = \begin{bmatrix} * & * \\ * & d \end{bmatrix}) \\ 0 & (\chi(-1) \neq (-1)^k), \end{cases}$$

where R is a complete set of representatives for $\Gamma_0(N)_\infty \backslash \Gamma_0(N)$. We also put

$$(7.2.61) \quad E_{k,N}^*(z, s) = E_{k,N}^*(z, s; \chi)$$

with the trivial character $\chi \pmod N$. Then we see, similarly to (7.1.30),

$$(7.2.62) \quad E_k(Nz, s; \chi_0, \chi) = 2L_N(k + 2s, \chi)E_{k,N}^*(z, s; \chi).$$

If $k > 0$, then $E_{k,N}^*(z, s; \chi)$ is holomorphic at $s = 0$ by Corollary 7.2.10. Therefore we may define $E_{k,N}^*(z; \chi)$ and $E_{k,N}^*(z)$ by

$$(7.2.63) \quad E_{k,N}^*(z; \chi) = E_{k,N}^*(z, 0; \chi),$$

$$(7.2.64) \quad E_{k,N}^*(z) = E_{k,N}^*(z, 0).$$

By Theorem 7.2.16(2) and (3), $E_{k,N}^*(z, \chi)$ belongs to $\mathcal{G}_k(\Gamma(N))$ except for $k = 2$ and χ is trivial.

Theorem 7.2.17. $E_{0,N}^*(z, s)$ has a simple pole at $s = 1$ and

$$\begin{aligned} \operatorname{Res}_{s=1} E_{0,N}^*(z, s) &= y^{-1} v(\Gamma_0(N) \backslash \mathbf{H})^{-1} \\ &= y^{-1} \left(\frac{\pi}{3} N \prod_{p|N} (1 + p^{-1}) \right)^{-1} \end{aligned}$$

Proof. The assertion is easily obtained by calculating the residue using Corollary 7.2.10(3) combined with Theorem 4.1.2(2) and Theorem 4.2.5(2). But we shall here give a rather direct proof of the first equality, which also reproves Theorem 4.1.2(2). We put

$$(7.2.65) \quad M(z, s) = \sum_{\gamma \in R} e^{-\operatorname{Im}(\gamma z)} |j(\gamma, z)|^{-2s-2},$$

where R is a complete set of representatives for $\Gamma_0(N) \backslash \Gamma_0(N)$. Since

$$1 - y \leq e^{-y} \leq 1 \quad \text{for } y > 0,$$

$M(z, s)$ is absolutely convergent if $\operatorname{Re}(s) > 0$. Further if s is a positive number, then

$$(7.2.66) \quad E_{0,N}^*(z, s+1) - E_{0,N}^*(z, s+2)y \leq M(z, s) \leq E_{0,N}^*(z, s+1).$$

Therefore

$$\begin{aligned} \lim_{s \rightarrow +0} sM(z, s) &= \operatorname{Res}_{s=1} E_{0,N}^*(z, s) \\ &= c/y, \quad \left(c = \left(\frac{\pi}{3} N \prod_{p|N} (1 + p^{-1}) \right)^{-1} \right), \end{aligned}$$

by Corollary 7.2.10(3) and (7.2.62). Now we have

$$\begin{aligned} (7.2.67) \quad \Gamma(s) &= \int_0^1 \int_0^1 e^{-y} y^{s-1} dx dy \\ &= \int_{\Gamma_0(N) \backslash \mathbf{H}} e^{-y} y^{s+1} dv(z) \\ &= \int_{\Gamma_0(N) \backslash \mathbf{H}} M(z, s) y^{s+1} dv(z). \end{aligned}$$

By (7.2.60), we see

$$E_{0,N}^*(z, s+1) = 1 + \sum_{\substack{\gamma \in R \\ \gamma \neq 1}} |j(\gamma, z)|^{-2s-2}.$$

Therefore by Theorem 7.2.9 and (7.2.62),

$$(7.2.68) \quad s \sum_{\substack{\gamma \in R \\ \gamma \neq 1}} |j(\gamma, z)|^{-2s-2} y^{s+1} \leq C \quad (y \rightarrow \infty, C: \text{constant})$$

and $sE_{0,N}^*(z, s+1)y^{s+1}$ is bounded on neighborhoods of cusps of $\Gamma_0(N)$ inequi-

valent to ∞ , uniformly on s ($0 \leq s \leq \varepsilon$). Since

$$M(z, s) = e^{-y} + \sum_{\substack{\gamma \in R \\ \gamma \neq 1}} e^{-\text{Im}(\gamma z)} |j(\gamma, z)|^{-2s-2},$$

we see that the integral

$$\int_{\Gamma_0(N) \backslash \mathbf{H}} sM(z, s)y^{s+1} dv(z)$$

is uniformly convergent by (7.2.68). Therefore

$$\begin{aligned} 1 &= \lim_{s \rightarrow 0} s\Gamma(s) \\ &= \lim_{s \rightarrow 0} \int_{\Gamma_0(N) \backslash \mathbf{H}} sM(z, s)y^{s+1} dv(z) \\ &= \int_{\Gamma_0(N) \backslash \mathbf{H}} \left(\lim_{s \rightarrow 0} sM(z, s)y^{s+1} \right) dv(z) \\ &= cv(\Gamma_0(N) \backslash \mathbf{H}). \end{aligned}$$

This implies the first equality. The second equality follows from this with a direct calculation of c by Corollary 7.2.10(3) and (7.2.62). \square

Theorem 7.2.18. *For a positive integer N , we have:*

- (1) $\mathcal{E}_2^{(1)}(\Gamma(N)) \cap \mathcal{E}_2(\Gamma(N)) = \mathcal{N}_2(\Gamma(N))$.
- (2) $\mathcal{E}_1^{(1)}(\Gamma(N)) = \mathcal{N}_1(\Gamma(N))$.

Proof. Let $f(z)$ be an element of $\mathcal{S}_k(N, \chi)$. Then by a similar argument to that in Theorem 2.6.10, we have

$$(7.2.69) \quad \int_{\Gamma_0(N) \backslash \mathbf{H}} \overline{f(z)} E_{k,N}^*(z, s; \chi) y^{k+2s-2} dx dy = 0,$$

if $\text{Re}(s)$ is sufficiently large. By Corollary 7.2.15(2), the integral is uniformly convergent on any compact subset of s -plane on which $E_{k,N}^*(z, s; \chi)$ is holomorphic. Therefore we see

$$(7.2.70) \quad \int_{\Gamma_0(N) \backslash \mathbf{H}} \overline{f(z)} E_{k,N}^*(z; \chi) y^{k-2} dx dy = 0.$$

If $k = 1$ or $k = 2$ and χ is not trivial, then this implies $E_{k,N}^*(z; \chi) \in \mathcal{N}_k(N, \chi)$, and therefore $E_{k,N}^*(z; \chi) \in \mathcal{N}_k(\Gamma(N))$ by Theorem 2.1.7. Assume $k = 2$. We shall prove

$$(7.2.71) \quad \int_{\Gamma(N) \backslash \mathbf{H}} \overline{f(z)} E_{2,N}^*(z) y^2 dv(z) = 0, \quad f(z) \in \mathcal{S}_2(\Gamma(N)).$$

We may assume $N \geq 6$ (since $\dim \mathcal{S}_2(\Gamma(N)) = 0$ if $N \leq 5$). We put

$$(7.2.72) \quad F_2(z, s) = \sum_{\gamma \in R'} (cz + d)^{-2} |cz + d|^{-2s},$$

where R' is a complete set of representatives for $\Gamma(N)_\infty \backslash \Gamma(N)$ and $\gamma = \begin{bmatrix} * & * \\ c & d \end{bmatrix}$.

Then by a similar calculation to that in (7.1.33), we see

$$(7.2.73) \quad F_2(z, s) = \frac{2}{\phi(N)} \sum_{\chi} E_{2,N}^*(z, s; \chi),$$

where χ runs over all characters mod N . Thus $F_2(z, s)$ is holomorphic at $s = 0$. We also put

$$(7.2.74) \quad F_2(z) = F_2(z, 0).$$

Then by a similar argument to that in Theorem 2.6.10, we have

$$(7.2.75) \quad \int_{\Gamma(N) \backslash \mathbf{H}} \overline{f(z)} F_2(z, s) y^{2s} dx dy = 0, \quad f(z) \in \mathcal{S}_2(\Gamma(N)),$$

and therefore,

$$(7.2.76) \quad \int_{\Gamma(N) \backslash \mathbf{H}} \overline{f(z)} F_2(z) y^2 dv(z) = 0, \quad f(z) \in \mathcal{S}_2(\Gamma(N)).$$

Since $E_{2,N}^*(z)$ is a linear combination of $F_2(z)$ and $E_{2,N}^*(z; \chi)$ (χ : non-trivial) by (7.2.73), we proved (7.2.71). Combining all together, we obtain

$$(7.2.77) \quad \int_{\Gamma(N) \backslash \mathbf{H}} \overline{f(z)} E_{k,N}^*(z; \chi) y^k dv(z) = 0, \quad f(z) \in \mathcal{S}_k(\Gamma(N)),$$

for any character χ mod N and any positive integer k . Since (7.1.17), (7.1.19), and (7.1.31) also hold for $k = 1$ and 2 ,

$$\{E_{k,N}^*(z; \chi) | \chi \in SL_2(\mathbb{Z})\}$$

generates $\mathcal{E}_k^{(1)}(\Gamma(N))$, so that

$$\mathcal{E}_2^{(1)}(\Gamma(N)) \cap \mathcal{G}_2(\Gamma(N)) \subset \mathcal{N}_2(\Gamma(N)), \quad \mathcal{E}_1^{(1)}(\Gamma(N)) \subset \mathcal{N}_1(\Gamma(N)).$$

The converse can be obtained by Theorem 4.7.2 and the following lemma. □

Lemma 7.2.19. *Let χ and ψ be primitive Dirichlet characters mod L and mod M , respectively, satisfying $\chi\psi(-1) = (-1)^k$. Let $f_k(z; \chi, \psi)$ be the modular form $f(z; \chi, \psi)$ of weight k defined in §4.7.*

(1) *If either χ or ψ is not trivial, then*

$$E_2(Mz; \chi, \psi) = (-8\pi^2 W(\psi)/M^2) f_2(z; \chi, \bar{\psi}).$$

(2) *For any prime number p ,*

$$E_2(z) - pE_2(pz) = -8\pi^2 f_2(z; \chi_0, \chi'),$$

where χ_0 is the principal character and χ' the trivial character mod p .

(3) $E_1(Mz; \chi, \psi) = (-4\pi i W(\psi)/M) f_1(z; \chi, \bar{\psi})$.

Proof. We see easily the equalities by comparing the Fourier coefficients by Theorem 7.2.12 and Theorem 7.2.13. □

Numerical Tables

As some applications of trace formulae in Chapter 6, we present here some tables. Table A is on the dimensions of modular forms, Table B gives eigenvalues and characteristic polynomials of Hecke operators operating on $\mathcal{S}_2(\Gamma_0(N))$, and

Table C is on the coefficients of primitive forms in $\mathcal{S}_2\left(N, \left(\frac{-}{N}\right)\right)$.

Table A was prepared by Y. Maeda, and Table B and Table C by H. Wada and N. Iwasaki.

Table A

This lists the dimensions of the following spaces:

- (i) $\dim \mathcal{S}_k(\Gamma_0(N))$.
Weights k , $2 \leq k \leq 50$;
Levels N , $1 \leq N \leq 50$,
 $50 < N < 100$: prime numbers.
- (ii) $\dim \mathcal{S}_k^0(\Gamma_0(N))$.
Weights and levels are as in (i).
- (iii) $\dim \mathcal{S}_k\left(q, \left(\frac{-}{q}\right)\right)$.
Weights k , $2 \leq k \leq 50$;
Levels q , $3 \leq q < 100$; prime numbers.

Dimension of $\mathcal{S}_k(\Gamma_0(N))$

$k \backslash N$	1	2	3	4	5	6	7	8	9	10	11	12	13	14	15
2	0	0	0	0	0	0	0	0	0	0	1	0	0	1	1
4	0	0	0	0	1	1	1	1	1	3	2	3	3	4	4
6	0	0	1	1	1	3	3	3	3	5	4	7	5	8	8
8	0	1	1	2	3	5	3	5	5	9	6	11	7	12	12
10	0	1	2	3	3	7	5	7	7	11	8	15	9	16	16
12	1	2	3	4	5	9	7	9	9	15	10	19	13	20	20
14	0	2	3	5	5	11	7	11	11	17	12	23	13	24	24
16	1	3	4	6	7	13	9	13	13	21	14	27	17	28	28
18	1	3	5	7	7	15	11	15	15	23	16	31	19	32	32
20	1	4	5	8	9	17	11	17	17	27	18	35	21	36	36
22	1	4	6	9	9	19	13	19	19	29	20	39	23	40	40
24	2	5	7	10	11	21	15	21	21	33	22	43	27	44	44
26	1	5	7	11	11	23	15	23	23	35	24	47	27	48	48
28	2	6	8	12	13	25	17	25	25	39	26	51	31	52	52
30	2	6	9	13	13	27	19	27	27	41	28	55	33	56	56
32	2	7	9	14	15	29	19	29	29	45	30	59	35	60	60
34	2	7	10	15	15	31	21	31	31	47	32	63	37	64	64
36	3	8	11	16	17	33	23	33	33	51	34	67	41	68	68
38	2	8	11	17	17	35	23	35	35	53	36	71	41	72	72
40	3	9	12	18	19	37	25	37	37	57	38	75	45	76	76
42	3	9	13	19	19	39	27	39	39	59	40	79	47	80	80
44	3	10	13	20	21	41	27	41	41	63	42	83	49	84	84
46	3	10	14	21	21	43	29	43	43	65	44	87	51	88	88
48	4	11	15	22	23	45	31	45	45	69	46	91	55	92	92
50	3	11	15	23	23	47	31	47	47	71	48	95	55	96	96

Dimension of $\mathcal{S}_k^0(\Gamma_0(N))$

$k \backslash N$	1	2	3	4	5	6	7	8	9	10	11	12	13	14	15
2	0	0	0	0	0	0	0	0	0	0	1	0	0	1	1
4	0	0	0	0	1	1	1	1	1	1	2	1	3	2	2
6	0	0	1	1	1	1	3	1	1	3	4	0	5	2	4
8	0	1	1	0	3	1	3	2	3	1	6	2	7	4	4
10	0	1	2	1	3	1	5	2	3	3	8	1	9	4	6
12	1	0	1	1	3	3	5	3	4	5	8	2	11	6	8
14	0	2	3	1	5	1	7	3	5	3	12	2	13	6	8
16	1	1	2	1	5	3	7	4	6	5	12	3	15	8	10
18	1	1	3	2	5	3	9	4	6	7	14	2	17	8	12
20	1	2	3	1	7	3	9	5	8	5	16	4	19	10	12
22	1	2	4	2	7	3	11	5	8	7	18	3	21	10	14
24	2	1	3	2	7	5	11	6	9	9	18	4	23	12	16
26	1	3	5	2	9	3	13	6	10	7	22	4	25	12	16
28	2	2	4	2	9	5	13	7	11	9	22	5	27	14	18
30	2	2	5	3	9	5	15	7	11	11	24	4	29	14	20
32	2	3	5	2	11	5	15	8	13	9	26	6	31	16	20
34	2	3	6	3	11	5	17	8	13	11	28	5	33	16	22
36	3	2	5	3	11	7	17	9	14	13	28	6	35	18	24
38	2	4	7	3	13	5	19	9	15	11	32	6	37	18	24
40	3	3	6	3	13	7	19	10	16	13	32	7	39	20	26
42	3	3	7	4	13	7	21	10	16	15	34	6	41	20	28
44	3	4	7	3	15	7	21	11	18	13	36	8	43	22	28
46	3	4	8	4	15	7	23	11	18	15	38	7	45	22	30
48	4	3	7	4	15	9	23	12	19	17	38	8	47	24	32
50	3	5	9	4	17	7	25	12	20	15	42	8	49	24	32

Dimension of $\mathcal{S}_k(\Gamma_0(N))$

$k \backslash N$	16	17	18	19	20	21	22	23	24	25	26	27	28	29	30
2	0	1	0	1	1	1	2	2	1	0	2	1	2	2	3
4	3	4	5	4	6	6	7	5	8	5	9	6	9	7	14
6	7	6	11	8	12	12	13	9	16	9	15	12	17	11	26
8	11	10	17	10	18	16	19	13	24	15	23	18	25	17	38
10	15	12	23	14	24	22	25	17	32	19	29	24	33	21	50
12	19	16	29	18	30	28	31	21	40	25	37	30	41	27	62
14	23	18	35	20	36	32	37	25	48	29	43	36	49	31	74
16	27	22	41	24	42	38	43	29	56	35	51	42	57	37	86
18	31	24	47	28	48	44	49	33	64	39	57	48	65	41	98
20	35	28	53	30	54	48	55	37	72	45	65	54	73	47	110
22	39	30	59	34	60	54	61	41	80	49	71	60	81	51	122
24	43	34	65	38	66	60	67	45	88	55	79	66	89	57	134
26	47	36	71	40	72	64	73	49	96	59	85	72	97	61	146
28	51	40	77	44	78	70	79	53	104	65	93	78	105	67	158
30	55	42	83	48	84	76	85	57	112	69	99	84	113	71	170
32	59	46	89	50	90	80	91	61	120	75	107	90	121	77	182
34	63	48	95	54	96	86	97	65	128	79	113	96	129	81	194
36	67	52	101	58	102	92	103	69	136	85	121	102	137	87	206
38	71	54	107	60	108	96	109	73	144	89	127	108	145	91	218
40	75	58	113	64	114	102	115	77	152	95	135	114	153	97	230
42	79	60	119	68	120	108	121	81	160	99	141	120	161	101	242
44	83	64	125	70	126	112	127	85	168	105	149	126	169	107	254
46	87	66	131	74	132	118	133	89	176	109	155	132	177	111	266
48	91	70	137	78	138	124	139	93	184	115	163	138	185	117	278
50	95	72	143	80	144	128	145	97	192	119	169	144	193	121	290

Dimension of $\mathcal{S}_k^o(\Gamma_0(N))$

$k \backslash N$	16	17	18	19	20	21	22	23	24	25	26	27	28	29	30
2	0	1	0	1	1	1	0	2	1	0	2	1	0	2	1
4	1	4	1	4	1	4	3	5	1	3	3	4	2	7	2
6	2	6	3	8	1	4	5	9	3	7	5	7	2	11	2
8	3	10	2	10	3	8	5	13	3	9	7	9	4	17	6
10	4	12	4	14	3	8	7	17	5	13	9	12	4	21	6
12	5	14	5	16	3	12	11	19	5	16	11	15	6	25	6
14	6	18	5	20	5	12	9	25	7	19	13	17	6	31	10
16	7	20	6	22	5	16	13	27	7	22	15	20	8	35	10
18	8	22	8	26	5	16	15	31	9	26	17	23	8	39	10
20	9	26	7	28	7	20	15	35	9	28	19	25	10	45	14
22	10	28	9	32	7	20	17	39	11	32	21	28	10	49	14
24	11	30	10	34	7	24	21	41	11	35	23	31	12	53	14
26	12	34	10	38	9	24	19	47	13	38	25	33	12	59	18
28	13	36	11	40	9	28	23	49	13	41	27	36	14	63	18
30	14	38	13	44	9	28	25	53	15	45	29	39	14	67	18
32	15	42	12	46	11	32	25	57	15	47	31	41	16	73	22
34	16	44	14	50	11	32	27	61	17	51	33	44	16	77	22
36	17	46	15	52	11	36	31	63	17	54	35	47	18	81	22
38	18	50	15	56	13	36	29	69	19	57	37	49	18	87	26
40	19	52	16	58	13	40	33	71	19	60	39	52	20	91	26
42	20	54	18	62	13	40	35	75	21	64	41	55	20	95	26
44	21	58	17	64	15	44	35	79	21	66	43	57	22	101	30
46	22	60	19	68	15	44	37	83	23	70	45	60	22	105	30
48	23	62	20	70	15	48	41	85	23	73	47	63	24	109	30
50	24	66	20	74	17	48	39	91	25	76	49	65	24	115	34

Dimension of $\mathcal{S}_k(q, (\bar{q}))$

$k \backslash q$	5	13	17	29	37	41	53	61	73	89	97
2	0	0	0	2	2	2	4	4	4	6	6
4	0	2	4	6	8	10	12	14	18	22	24
6	2	6	6	12	16	16	22	26	30	36	40
8	2	6	10	16	20	24	30	34	42	52	56
10	4	10	12	22	28	30	40	46	54	66	72
12	4	12	16	26	34	38	48	56	68	82	90
14	6	14	18	32	40	44	58	66	78	96	104
16	6	16	22	36	46	52	66	76	92	112	122
18	8	20	24	42	54	58	76	88	104	126	138
20	8	20	28	46	58	66	84	96	116	142	154
22	10	24	30	52	66	72	94	108	128	156	170
24	10	26	34	56	72	80	102	118	142	172	188
26	12	28	36	62	78	86	112	128	152	186	202
28	12	30	40	66	84	94	120	138	166	202	220
30	14	34	42	72	92	100	130	150	178	216	236
32	14	34	46	76	96	108	138	158	190	232	252
34	16	38	48	82	104	114	148	170	202	246	268
36	16	40	52	86	110	122	156	180	216	262	286
38	18	42	54	92	116	128	166	190	226	276	300
40	18	44	58	96	122	136	174	200	240	292	318
42	20	48	60	102	130	142	184	212	252	306	334
44	20	48	64	106	134	150	192	220	264	322	350
46	22	52	66	112	142	156	202	232	276	336	366
48	22	54	70	116	148	164	210	242	290	352	384
50	24	56	72	122	154	170	220	252	300	366	398

Dimension of $\mathcal{S}_k(q, (\bar{q}))$

$k \backslash q$	3	7	11	19	23	31	43	47	59	67	71	79	83
3	0	1	1	3	3	5	7	7	9	11	11	13	13
5	0	1	3	5	7	9	13	15	19	21	23	25	27
7	1	3	5	9	11	15	21	23	29	33	35	39	41
9	2	5	7	13	15	21	29	31	39	45	47	53	55
11	2	5	9	15	19	25	35	39	49	55	59	65	69
13	3	7	11	19	23	31	43	47	59	67	71	79	83
15	4	9	13	23	27	37	51	55	69	79	83	93	97
17	4	9	15	25	31	41	57	63	79	89	95	105	111
19	5	11	17	29	35	47	65	71	89	101	107	119	125
21	6	13	19	33	39	53	73	79	99	113	119	133	139
23	6	13	21	35	43	57	79	87	109	123	131	145	153
25	7	15	23	39	47	63	87	95	119	135	143	159	167
27	8	17	25	43	51	69	95	103	129	147	155	173	181
29	8	17	27	45	55	73	101	111	139	157	167	185	195
31	9	19	29	49	59	79	109	119	149	169	179	199	209
33	10	21	31	53	63	85	117	127	159	181	191	213	223
35	10	21	33	55	67	89	123	135	169	191	203	225	237
37	11	23	35	59	71	95	131	143	179	203	215	239	251
39	12	25	37	63	75	101	139	151	189	215	227	253	265
41	12	25	39	65	79	105	145	159	199	225	239	265	279
43	13	27	41	69	83	111	153	167	209	237	251	279	293
45	14	29	43	73	87	117	161	175	219	249	263	293	307
47	14	29	45	75	91	121	167	183	229	259	275	305	321
49	15	31	47	79	95	127	175	191	239	271	287	319	335

Table B

For $N = 11, 17$ and 19 , eigenvalues a_p of $T(p)$ on $\mathcal{S}_2(\Gamma_0(N))$ for prime numbers p are given.

For $N = 23, 29, 41, 47, 61, 67$ and 71 , the coefficients of the characteristic polynomials $F(X)$ of $T(p)$ on $\mathcal{S}_2(\Gamma_0(N))$ are given. When $F(X)$ is reducible over \mathbb{Q} , the coefficients of each irreducible factor are presented. They are separated by “/”. For example, when $N = 47$ and $p = 2$,

$$1, -1, -5, 5, -1$$

should be read as

$$X^4 - X^3 - 5X^2 + 5X - 1,$$

and when $N = 61$ and $p = 2$,

$$1 \ 1/ \ 1 \ -1 \ -3 \ 1$$

should be read as

$$(X + 1)(X^3 - X^2 - 3X + 1).$$

We note the order of decomposition is not consistent for p 's.

The polynomial f^* in the decomposition for $N = 61, 67$ is the part corresponding to the cusp forms invariant by ω_N .

$N = 11 \quad \dim \mathcal{S}_2(\Gamma_0(11)) = 1$

p	a_p	p	a_p	p	a_p	p	a_p	p	a_p	p	a_p	p	a_p
2	-2	79	-10	191	17	311	12	439	40	577	33	709	-25
3	-1	83	-6	193	4	313	-1	443	-11	587	28	719	15
5	1	89	15	197	-2	317	13	449	35	593	44	727	3
7	-2	97	-7	199	0	331	7	457	-12	599	40	733	-36
11	1	101	2	211	12	337	-22	461	12	601	2	739	50
13	4	103	-16	223	19	347	28	463	-11	607	-22	743	4
17	-2	107	18	227	18	349	30	467	-27	613	-16	751	-23
19	0	109	10	229	15	353	-21	479	20	617	18	757	-22
23	-1	113	9	233	24	359	-20	487	23	619	-25	761	12
29	0	127	8	239	-30	367	-17	491	-8	631	7	769	20
31	7	131	-18	241	-8	373	-26	499	20	641	-33	773	-6
37	3	137	-7	251	-23	379	-5	503	-26	643	29	787	-32
41	-8	139	10	257	-2	383	-1	509	15	647	-7	797	53
43	-6	149	-10	263	14	389	-15	521	-3	653	-41	809	0
47	8	151	2	269	10	397	-2	523	-16	659	10	811	-38
53	-6	157	-7	271	-28	401	2	541	-8	661	37	821	22
59	5	163	4	277	-2	409	-30	547	8	673	14	823	39
61	12	167	-12	281	-18	419	20	557	-2	677	-42	827	-52
67	-7	173	-6	283	4	421	22	563	4	683	-16	829	25
71	-3	179	-15	293	24	431	-18	569	0	691	17	839	-5
73	4	181	7	307	8	433	-11	571	-28	701	2	853	14

$N = 17$ $\dim \mathcal{S}_2(\Gamma_0(17)) = 1$

p	a_p	p	a_p	p	a_p	p	a_p	p	a_p	p	a_p	p	a_p	p	a_p
2	-1	79	12	191	-16	311	28	439	-20	577	-14	709	-34	857	10
3	0	83	-4	193	2	313	-22	443	28	587	4	719	4	859	52
5	-2	89	10	197	-18	317	-10	449	34	593	18	727	40	863	16
7	4	97	2	199	-20	331	4	457	-6	599	-24	733	-50	877	6
11	0	101	-10	211	8	337	-14	461	-2	601	10	739	28	881	-46
13	-2	103	8	223	24	347	32	463	32	607	20	743	12	883	-12
17	1	107	8	227	-24	349	-18	467	12	613	-26	751	20	887	12
19	-4	109	6	229	6	353	-30	479	36	617	-6	757	22	907	32
23	4	113	-14	233	-6	359	0	487	20	619	-48	761	-22	911	-4
29	6	127	8	239	-16	367	28	491	20	631	16	769	-14	919	24
31	4	131	16	241	18	373	6	499	-40	641	-30	773	-26	929	-30
37	-2	137	-6	251	12	379	-8	503	-12	643	32	787	-32	937	10
41	-6	139	-8	257	18	383	-24	509	-2	647	8	797	-50	941	6
43	4	149	-10	263	-16	389	6	521	26	653	6	809	26	947	32
47	0	151	-16	269	22	397	6	523	-36	659	4	811	40	953	-22
53	6	157	-2	271	-16	401	-14	541	6	661	38	821	-18	967	0
59	-12	163	24	277	14	409	26	547	-32	673	2	823	20	971	-12
61	-10	167	-4	281	-6	419	8	557	30	677	30	827	-48	977	18
67	4	173	22	283	-16	421	22	563	-4	683	-40	829	-34	983	12
71	-4	179	12	293	6	431	12	569	-38	691	-8	839	20	991	-12
73	-6	181	-2	307	-12	433	2	571	-32	701	-18	853	14	997	46

$N = 19$ $\dim \mathcal{S}_2(\Gamma_0(19)) = 1$

p	a_p	p	a_p	p	a_p	p	a_p	p	a_p	p	a_p	p	a_p	p	a_p
2	0	79	8	191	3	311	-3	439	-10	577	11	709	26	857	18
3	-2	83	12	193	-4	313	-10	443	-3	587	45	719	15	859	-49
5	3	89	12	197	18	317	6	449	0	593	-42	727	-19	863	18
7	-1	97	8	199	11	331	-28	457	-37	599	-36	733	-22	877	-22
11	3	101	6	211	14	337	32	461	9	601	26	739	11	881	-27
13	-4	103	14	223	-10	347	21	463	-31	607	32	743	-24	883	47
17	-3	107	-18	227	12	349	17	467	-27	613	29	751	32	887	18
19	1	109	-16	229	5	353	-6	479	-12	617	9	757	-25	907	8
23	0	113	6	233	-21	359	15	487	2	619	44	761	33	911	-6
29	6	127	2	239	15	367	8	491	12	631	11	769	23	919	20
31	-4	131	-15	241	-10	373	-4	499	5	641	0	773	-6	929	-18
37	2	137	-3	251	21	379	-34	503	12	643	-13	787	-4	937	-7
41	-6	139	-13	257	0	383	12	509	0	647	27	797	-12	941	-18
43	-1	149	21	263	9	389	15	521	0	653	-39	809	-9	947	-36
47	-3	151	-10	269	24	397	-7	523	38	659	-30	811	-16	953	-48
53	12	157	14	271	-16	401	12	541	-25	661	32	821	33	967	-40
59	-6	163	20	277	-19	409	-4	547	-28	673	-10	823	-49	971	60
61	-1	167	-18	281	6	419	-12	557	21	677	-42	827	12	977	24
67	-4	173	-18	283	-13	421	8	563	6	683	36	829	-16	983	-36
71	6	179	-18	293	-12	431	-24	569	-24	691	17	839	18	991	-34
73	-7	181	2	307	20	433	2	571	-4	701	6	853	26	997	17

Table B

 $N = 23$ $\dim \mathcal{S}_2(\Gamma_0(23)) = 2$

p				p				p			
2	1	1	-1	269	1	-2	-79	617	1	24	124
3	1	0	-5	271	1	-8/	1 -8	619	1	-12	-144
5	1	2	-4	277	1	-22	101	631	1	20	-400
7	1	-2	-4	281	1	22	116	641	1	-28	-784
11	1	6	4	283	1	-42	396	643	1	10	-580
13	1	-3/	1 -3	293	1	12	16	647	1	0	-45
17	1	-6	4	307	1	-28	176	653	1	14	-931
19	1	2/	1 2	311	1	-4	-121	659	1	-10	-220
23	1	-1/	1 -1	313	1	-4	-496	661	1	28	116
29	1	3/	1 3	317	1	-24	-36	673	1	-3/	1 -3
31	1	0	-45	331	1	8	-229	677	1	-18/	1 -18
37	1	-2	-4	337	1	-20	-80	683	1	-4	-601
41	1	-2	-19	347	1	-16	-256	691	1	-32	176
43	1	0/	1 0	349	1	-22	-59	701	1	30	100
47	1	0	-5	353	1	26	-331	709	1	26	-676
53	1	8	-4	359	1	4	-316	719	1	24	64
59	1	-4	-16	367	1	-14	-76	727	1	42	396
61	1	-4	-76	373	1	-2	-44	733	1	58	836
67	1	10	-20	379	1	-4	-496	739	1	-76	1319
71	1	-20	95	383	1	-32	176	743	1	-42	36
73	1	-22	101	389	1	-60	880	751	1	44	-16
79	1	4	-76	397	1	22	-59	757	1	46	-76
83	1	22	116	401	1	6	-116	761	1	-30	-755
89	1	12	16	409	1	2	-499	769	1	6	-396
97	1	-22	76	419	1	36	144	773	1	20	80
101	1	0	-20	421	1	34	244	787	1	-76	1264
103	1	-14	-76	431	1	44	464	797	1	24	-356
107	1	0	-180	433	1	-58	716	809	1	-60	580
109	1	0/	1 0	439	1	24	99	811	1	80	1355
113	1	-22	116	443	1	-36	-81	821	1	60	820
127	1	28	151	449	1	12	-44	823	1	12	-1089
131	1	-24	99	457	1	-30	-180	827	1	-12	16
137	1	8	-304	461	1	-6	-11	829	1	0	-1620
139	1	8	-29	463	1	20/	1 20	839	1	42	36
149	1	-12	-284	467	1	44	404	853	1	48	396
151	1	-4	-1	479	1	-14	-556	857	1	6	-11
157	1	-4	-176	487	1	16	19	859	1	20	55
163	1	16	59	491	1	-48	331	863	1	-24	-981
167	1	-12	16	499	1	-52	631	877	1	64	1004
173	1	-28	116	503	1	36	244	881	1	-66	964
179	1	12	-9	509	1	-6	-971	883	1	-4/	1 -4
181	1	-2	-244	521	1	-36	144	887	1	12	-809
191	1	30	100	523	1	-42	36	907	1	0	-1620
193	1	-2	-79	541	1	42	261	911	1	0	-980
197	1	-6	-11	547	1	-8	-1109	919	1	-42	36
199	1	38	316	557	1	-12	-144	929	1	66	1009
211	1	20	-80	563	1	48	496	937	1	-46	404
223	1	-4/	1 -4	569	1	22	-4	941	1	18	164
227	1	2	-124	571	1	42	396	947	1	44	359
229	1	12/	1 12	577	1	-10	-295	953	1	-32	236
233	1	22	101	587	1	36	279	967	1	12	-1089
239	1	-32	251	593	1	-12	-44	971	1	-24	124
241	1	6	-396	599	1	-32	-64	977	1	78	1276
251	1	-18	36	601	1	-58	521	983	1	72	1276
257	1	6	-11	607	1	-44	464	991	1	-24/	1 -24
263	1	12	-44	613	1	2	-44	997	1	20	-620

$N = 29$ $\dim \mathcal{S}_2(\Gamma_0(29)) = 2$

p				p				p				
2	1	2	-1	269	1	-12	-612	617	1	-24	16	
3	1	-2	-1	271	1	-2	-241	619	1	-70	1223	
5	1	1/	1	277	1	12	-92	631	1	68	1148	
7	1	0	-8	281	1	-30	-63	641	1	4	-388	
11	1	-2	-1	283	1	-12	4	643	1	-48	504	
13	1	2	-7	293	1	-4	-28	647	1	-68	1124	
17	1	4	-4	307	1	14	-49	653	1	32	56	
19	1	-6/	1	311	1	-28	68	659	1	-26	167	
23	1	4	-28	313	1	-14	41	661	1	-44	356	
29	1	-1/	1	317	1	12	-612	673	1	-2	-511	
31	1	-6	-41	331	1	2	-1	677	1	22/	1	22
37	1	4/	1	337	1	-4	-388	683	1	-8	-272	
41	1	-8	-56	347	1	12	-36	691	1	-48/	1	-48
43	1	-10	23	349	1	-18	-119	701	1	18	-887	
47	1	-2	-17	353	1	-20	-188	709	1	-30	25	
53	1	-2	-71	359	1	-22	71	719	1	12	-164	
59	1	-4	-28	367	1	-18/	1	727	1	20	-28	
61	1	4	-4	373	1	30	97	733	1	-8	-2032	
67	1	0	-32	379	1	-20	-188	739	1	6	-41	
71	1	12	28	383	1	24	72	743	1	-36	292	
73	1	-4/	1	389	1	-40	112	751	1	-28	68	
79	1	2	-1	397	1	-50	593	757	1	-68	1084	
83	1	-4	-28	401	1	26	137	761	1	-12	-1532	
89	1	8	-56	409	1	4	-284	769	1	36	-644	
97	1	8	-56	419	1	36	252	773	1	56	712	
101	1	16	32	421	1	-12	-932	787	1	12	-2276	
103	1	4	-4	431	1	-28	164	797	1	4	-2884	
107	1	24	136	433	1	-16	-448	809	1	-16	-736	
109	1	-14	17	439	1	12	4	811	1	-16	56	
113	1	4	-124	443	1	60	868	821	1	-14	-23	
127	1	20	68	449	1	36	36	823	1	52	-124	
131	1	-20	-28	457	1	-36	36	827	1	-46	431	
137	1	-12/	1	461	1	-14/	1	829	1	20	-292	
139	1	-14/	1	463	1	26/	1	839	1	30	175	
149	1	10	17	467	1	6	-1241	853	1	12	-252	
151	1	0	-200	479	1	6	-89	857	1	18	73	
157	1	0	-72	487	1	40	328	859	1	-14	-113	
163	1	-22	71	491	1	34	271	863	1	28	-772	
167	1	12	28	499	1	-4	-284	877	1	46	329	
173	1	-36	292	503	1	-26	7	881	1	-14/	1	-14
179	1	-4	-68	509	1	38	289	883	1	8	-1784	
181	1	6	-119	521	1	30	25	887	1	-54	631	
191	1	-28	68	523	1	-32	128	907	1	12	-764	
193	1	16	56	541	1	32	224	911	1	62	719	
197	1	-2/	1	547	1	-32	-136	919	1	12	-164	
199	1	-16	-8	557	1	12	-92	929	1	-60	772	
211	1	2	-337	563	1	10	7	937	1	-12	-476	
223	1	12	28	569	1	68	1124	941	1	34	-1279	
227	1	-12	-164	571	1	16	-448	947	1	-42	103	
229	1	24	72	577	1	20	-292	953	1	26	-343	
233	1	-14	-79	587	1	-4	-28	967	1	62	943	
239	1	28	164	593	1	22	49	971	1	20	68	
241	1	14	-79	599	1	34	-433	977	1	-78	1513	
251	1	-26	119	601	1	40	392	983	1	-10	-697	
257	1	42	433	607	1	-10	-137	991	1	20	92	
263	1	-14	31	613	1	9/	1	997	1	0	-800	

$N = 41$ $\dim \mathcal{S}_2(\Gamma_0(41)) = 3$

p					p				
2	1	1	-5	-1	263	1	-20	-740	12506
3	1	0	-4	2	269	1	-10	-228	-200
5	1	2	-4	-4	271	1	4	-16	-32
7	1	-6	8	-2	277	1	2	-332	2116
11	1	-2	-20	50	281	1	-38	428	-1352
13	1	2	-12	-8	283	1	4	-448	-1376
17	1	2/1	2/1	2	293	1	-42	140	5528
19	1	-4	-16	-10	307	1	40	480	1808
23	1	-4	-32	-32	311	1	-10	-360	-1718
29	1	6	-4	-40	313	1	34	76	-712
31	1	-16	64	-32	317	1	42	452	344
37	1	6	-36	-108	331	1	-6	-576	4658
41	1	-1/1	-1/1	-1	337	1	38	164	-3676
43	1	4	-8	-16	347	1	-12	-144	1678
47	1	0	-120	-502	349	1	50	828	4540
53	1	-6	-4	8	353	1	22	-172	-4388
59	1	8	-16	-160	359	1	24	-256	-6400
61	1	-2	-52	184	367	1	16	-216	-1648
67	1	2	-20	-50	373	1	54	716	2248
71	1	-20	84	134	379	1	-48	656	-2720
73	1	2	-180	244	383	1	22	-32	-1798
79	1	-32	328	-1090	389	1	-2	-596	3560
83	1	0	-64	-128	397	1	-22	68	152
89	1	6	-148	-920	401	1	6	-700	-5132
97	1	-6	-52	248	409	1	-6	-436	-2740
101	1	-18	-12	488	419	1	4	-1224	80
103	1	4	-256	-1424	421	1	-22	-100	2600
107	1	16	0	-256	431	1	12	-424	-4688
109	1	6	-124	-760	433	1	-30	-1044	29592
113	1	-6	-148	-116	439	1	-50	-268	25750
127	1	-16	48	-32	443	1	-80	2048	-16976
131	1	20	80	-208	449	1	-22	76	520
137	1	-18	-148	2344	457	1	-10	-116	1096
139	1	12	-352	-3680	461	1	38	300	100
149	1	-10	-212	1720	463	1	4	-516	1286
151	1	-28	196	-338	467	1	56	1024	6112
157	1	14	-172	-2392	479	1	2	-192	670
163	1	16	32	-128	487	1	-8	-1552	2416
167	1	14	28	-122	491	1	8	-352	-3616
173	1	30	236	232	499	1	-48	764	-4030
179	1	-2	-296	-610	503	1	40	176	-3098
181	1	34	140	-2264	509	1	50	532	-200
191	1	-14	-412	3562	521	1	42	188	-712
193	1	26	188	248	523	1	-20	-720	5696
197	1	-50	780	-3592	541	1	-30	-436	14044
199	1	-46	612	-2510	547	1	68	1168	3622
211	1	-10	-160	1382	557	1	50	684	2536
223	1	8	-64	-256	563	1	-58	732	-1934
227	1	-8	-28	214	569	1	-2	-44	20
229	1	6	-268	-1240	571	1	6	-1212	-9838
233	1	-26	-116	4616	577	1	46	364	-2008
239	1	-16	-48	430	587	1	18	104	194
241	1	-6	-388	2792	593	1	38	-564	-9176
251	1	28	208	464	599	1	40	-432	-160
257	1	-10	-276	-344	601	1	-26	-116	1928

$N = 47$

$\dim \mathcal{S}_2(\Gamma_0(47)) = 4$

P						P					
2	1	-1	-5	5	-1	263	1	16	-467	-3376	56349
3	1	0	-7	4	1	269	1	-32	168	2432	-17328
5	1	2	-16	-16	48	271	1	44	101	-16720	-182799
7	1	-4	-7	44	-43	277	1	14	-357	-6350	-22639
11	1	6	-4	-56	-48	281	1	-26	-56	2704	8144
13	1	-8	0	56	48	283	1	52	757	760	-30439
17	1	-6	-21	74	141	293	1	-6	-592	2000	72208
19	1	0	-16	-8	16	307	1	-48	689	-2212	-9839
23	1	6	-20	-40	-16	311	1	26	-400	-10656	-47248
29	1	10	20	-8	-16	313	1	6	-248	-1792	3824
31	1	8	0	-56	48	317	1	-20	-592	10216	21936
37	1	-10	15	34	9	331	1	56	977	4524	-12911
41	1	-6	-8	32	-16	337	1	-90	3003	-44026	239373
43	1	-2	-80	-112	432	347	1	16	-803	-10336	103341
47	1	-1/	1 -1/	1 -1/	1 -1	349	1	-18	-524	4232	49616
53	1	6	-101	-314	2429	353	1	30	-441	-16902	-80919
59	1	-4	-115	704	-519	359	1	0	-312	-2776	-6704
61	1	6	-73	10	337	367	1	4	-304	64	5888
67	1	-10	-120	752	3184	373	1	-24	-616	18536	-103184
71	1	12	-19	-320	657	379	1	24	141	-104	-1523
73	1	-22	60	1368	-7664	383	1	-16	-171	1984	10629
79	1	-20	77	240	-47	389	1	42	344	-656	-752
83	1	-20	80	192	-256	397	1	74	2027	24398	109001
89	1	6	-161	206	4841	401	1	42	67	-11594	-73039
97	1	-30	179	1634	-14307	409	1	0	-544	-4160	9472
101	1	22	35	-1398	-5903	419	1	8	-868	-4240	104816
103	1	20	77	-240	-47	421	1	-2	-112	112	2832
107	1	-12	-84	848	1488	431	1	12	-1099	-21728	-56807
109	1	6	-276	-1064	5776	433	1	-18	-32	1216	-2128
113	1	4	-216	-1656	-3024	439	1	-20	-576	17024	-108288
127	1	-22	-76	4088	-20688	443	1	6	-744	-5536	10512
131	1	-28	173	-144	-199	449	1	26	-296	-11536	-70864
137	1	-36	376	-1256	368	457	1	-62	899	1158	-35303
139	1	28	-136	-7992	-41488	461	1	-56	288	24896	-320256
149	1	6	-189	-1030	721	463	1	-22	-1412	25048	7824
151	1	0	-224	8	12368	467	1	-24	-712	4064	59152
157	1	2	-25	-78	-59	479	1	0	-559	1348	18217
163	1	-6	-56	304	-304	487	1	-20	-224	640	-256
167	1	-6	-60	152	912	491	1	12	-375	-2012	21973
173	1	42	503	1234	-371	499	1	-36	376	-328	-8752
179	1	-28	0	3184	752	503	1	40	-64	-10248	-29872
181	1	36	408	1304	-1328	509	1	16	-184	-3072	-5552
191	1	-20	-48	320	768	521	1	-58	415	13186	10089
193	1	-48	732	-4208	7984	523	1	-20	-624	3136	256
197	1	12	-336	-2224	7984	541	1	26	-853	-28918	-204739
199	1	2	-300	-2952	-7472	547	1	26	-604	-15880	-43984
211	1	-2	-652	4344	17872	557	1	-6	-1408	-13024	-13584
223	1	2	-824	-928	39056	563	1	-16	-216	5016	-22544
227	1	14	-248	-2896	8912	569	1	20	-16	-856	1008
229	1	-10	-768	8272	2576	571	1	-32	321	-932	-719
233	1	-2	-192	-1216	-2128	577	1	26	140	-88	-1296
239	1	-8	-475	472	8741	587	1	-84	2160	-16832	40192
241	1	-18	-165	3382	-11723	593	1	-14	-500	4040	-7536
251	1	4	-667	1888	21441	599	1	40	-152	-10784	27728
257	1	24	-264	-3080	6576	601	1	-6	-365	-2414	-3259

Table B

 $N = 61$ $\dim \mathcal{S}_2(\Gamma_0(61)) = 4$

p	$F(x) = f^*(x)f(x)$						p	$F(x) = f^*(x)f(x)$					
2	1	1/	1	-1	-3	1	263	1	16/	1	28	20	-2732
3	1	2/	1	-2	-4	4	269	1	18/	1	10	-268	-1160
5	1	3/	1	1	-9	-13	271	1	-14/	1	2	-496	-2404
7	1	-1/	1	3	-1	-1	277	1	-10/	1	-4	-256	92
11	1	5/	1	-13	53	-67	281	1	0/	1	-28	176	272
13	1	-1/	1	9	11	-37	283	1	-6/	1	-34	232	-68
17	1	-4/	1	2	-8	4	293	1	-18/	1	2	-668	856
19	1	4/	1	0	-48	-20	307	1	19/	1	-7	-291	919
23	1	9/	1	-5	5	1	311	1	15/	1	-15	-43	823
29	1	6/	1	-4	-4	20	313	1	6/	1	30	188	-536
31	1	0/	1	2	-76	116	317	1	30/	1	-58	1068	-6344
37	1	-8/	1	6	-36	-108	331	1	17/	1	13	35	25
41	1	-5/	1	-3	-61	191	337	1	2/	1	-26	-748	17896
43	1	8/	1	14	56	68	347	1	-8/	1	-32	264	-556
47	1	-4/	1	4	-88	16	349	1	24/	1	-14	-116	-380
53	1	-6/	1	2	-12	-8	353	1	-19/	1	15	-1009	-18043
59	1	-9/	1	-29	231	-325	359	1	-12/	1	-14	-564	8780
61	1	1/	1	-1/	1	-1/	367	1	-14/	1	38	428	1352
67	1	7/	1	-9	-85	559	373	1	10/	1	-24	-532	7108
71	1	8/	1	-14	-12	92	379	1	14/	1	-18	-696	12580
73	1	11/	1	1	-45	-25	383	1	-5/	1	37	297	131
79	1	-3/	1	-13	-51	625	389	1	14/	1	34	324	920
83	1	-4/	1	8	-64	-256	397	1	-8/	1	-6	-580	6652
89	1	4/	1	4	-56	80	401	1	-16/	1	28	208	464
97	1	14/	1	-10	-116	1096	409	1	-30/	1	2	-196	680
101	1	0/	1	10	0	-148	419	1	-4/	1	-50	-92	21380
103	1	-4/	1	-12	0	108	421	1	-8/	1	-2	-8	-4
107	1	2/	1	-26	92	1096	431	1	-6/	1	-2	-388	-1304
109	1	17/	1	-13	3	145	433	1	8/	1	44	584	2096
113	1	-1/	1	9	-133	-1061	439	1	0/	1	44	464	860
127	1	-6/	1	18	68	52	443	1	-12/	1	4	-256	-1424
131	1	16/	1	-8	-24	92	449	1	35/	1	29	191	335
137	1	-9/	1	-3	-253	859	457	1	20/	-	-90	2672	-26108
139	1	11/	1	3	-1	-5	461	1	18/	1	-6	-756	2808
149	1	-19/	1	-9	11	5	463	1	4/	1	-36	-48	3904
151	1	-11/	1	-3	-277	2033	467	1	-11	1	21	35	-691
157	1	4/	1	10	-300	-3412	479	1	-14/	1	-22	-76	-40
163	1	-18/	1	-10	-284	-668	487	1	12/	1	-20	-176	-4
167	1	12/	1	32	148	-1604	491	1	28/	1	-8	-164	-388
173	1	-10/	1	10	-4	-8	499	1	-13/	1	-45	-225	16875
179	1	18/	1	-42	476	-760	503	1	-10/	1	22	-48	-604
181	1	-8/	1	20	-80	-1088	509	1	-28/	1	58	1076	6340
191	1	-3/	1	-31	139	-167	521	1	20/	1	58	140	-23300
193	1	8/	1	20	80	-64	523	1	9/	1	19	-483	-871
197	1	3/	1	29	203	323	541	1	-28/	1	8	-928	8576
199	1	-6/	1	50	812	4280	547	1	29/	1	31	169	137
211	1	-4/	1	-22	-52	764	557	1	28/	1	40	320	-512
223	1	-23/	1	11	-183	-1343	563	1	10/	1	22	-212	-4588
227	1	-21/	1	-11	-483	5891	569	1	15/	1	1	-33	-85
229	1	-9/	1	9	-133	-25	571	1	-38/	1	46	252	344
233	1	14/	1	40	440	796	577	1	-10/	1	-8	-512	5996
239	1	-2/	1	38	404	1220	587	1	-32/	1	22	-268	-1916
241	1	3/	1	-7	-345	1675	593	1	6/	1	-12	0	108
251	1	12/	1	-38	296	-548	599	1	35/	1	-45	-225	16875
257	1	22/	1	-2	-36	184	601	1	43/	1	-15	-205	587

$N = 67$ $\dim \mathcal{S}_2(\Gamma_0(67)) = 5$

p	$F(x) = f^*(x)f_1(x)f_2(x)$							
2	1	3	1/	1	-2/	1	1	-1
3	1	3	1/	1	2/	1	-1	-1
5	1	3/	1	3/	1	-2/	1	-4
7	1	1	-11/	1	2/	1	-1	-1
11	1	0	-5/	1	4/	1	-1/	1
13	1	7	1/	1	-2/	1	1	-1
17	1	6	4/	1	-3/	1	-6	4
19	1	-1	-11/	1	-7/	1	11	29
23	1	-6	-11/	1	-9/	1	2	-19
29	1	6	-11/	1	5/	1	-10	5
31	1	1/	1	1/	10/	1	0	-45
37	1	1	-11/	1	1/	1	-3	1
41	1	3	1/	1	0/	1	-5	-25
43	1	-3	-9/	1	2/	1	9	-11
47	1	15	55/	1	1/	1	7	11
53	1	9/	1	9/	1	-10/	1	0
59	1	-6/	1	-6/	1	-9/	1	6/
61	1	7	-89/	1	2/	1	9	9
67	1	1/	1	1/	1	-1/	1	-1
71	1	12	31/	1	0/	1	0	-245
73	1	4/	1	4/	1	7/	1	-8/
79	1	7	-89/	1	8/	1	11	-31
83	1	15	-5/	1	-4/	1	-13	31
89	1	0	-5/	1	-7/	1	16	19
97	1	-2	-179/	1	0/	1	0	-45
101	1	9	-11/	1	-2/	1	-19	59
103	1	5	-95/	1	16/	1	-3	1
107	1	-24	99/	1	7/	1	-16	19
109	1	3	-9/	1	-2/	1	-9	-11
113	1	-33	271/	1	12/	1	-11	-71
127	1	5	-5/	1	-7/	1	21	79
131	1	3/	1	3/	1	12/	1	-6
137	1	12	-9/	1	-12/	1	26	149
139	1	3/	1	3/	1	-22/	1	-24
149	1	-9	-191/	1	-21/	1	3	-59
151	1	1/	1	1/	1	-3/	1	-6
157	1	-13	-59/	1	-9/	1	-13	-239
163	1	7	1/	1	-19/	1	-13	41
167	1	-12	-284/	1	-24/	1	-14/	1
173	1	39	349/	1	-11/	1	-17	61
179	1	18	76/	1	12/	1	-6	-36
181	1	7	-89/	1	-7/	1	11	19
191	1	6	-11/	1	6/	1	32	211
193	1	-27	171/	1	23/	1	1	-1
197	1	18	61/	1	2/	1	-36	319
199	1	13	-239/	1	-7/	1	-39	349
211	1	11	19/	1	12/	1	-1	-61
223	1	-18	36/	1	-11/	1	-2	-404
227	1	3	-359/	1	-3/	1	-21	-171
229	1	31	229/	1	-4/	1	7	-269
233	1	-12	16/	1	-10/	1	20	-80
239	1	27	151/	1	20/	1	-15	-155
241	1	-45	495/	1	19/	1	-17	11
251	1	-18	76/	1	2/	1	14	-196
257	1	18	-239/	1	1/	1	2	-79

$N = 71$ $\dim \mathcal{S}_2(\Gamma_0(71)) = 6$

p	$F(x) = f_1(x)f_2(x)$								
2	1	0	-5	3/	1	1	-4	-3	
3	1	1	-8	-3/	1	-1	-4	3	
5	1	3	-2	-7/	1	-5	-2	25	
7	1	-2	-16	24/	1	-2	-16	24	
11	1	2	-16	-24/	1	0	-20	24	
13	1	-4/	1	-4/	1	6	-8	-56	
17	1	-2	-16	24/	1	2	-32	-24	
19	1	-11	36	-35/	1	-1	-20	-25	
23	1	4/	1	4/	1	-8	-12	72	
29	1	5	-2	-25/	1	-11	14	71	
31	1	-4/	1	-4/	1	6	-8	-56	
37	1	-9	-26	37/	1	15	70	97	
41	1	-14	48	-8/	1	2	-68	56	
43	1	17	72	81/	1	-13	48	-45	
47	1	10	0	-72/	1	-4	-28	40	
53	1	0	-20	-24/	1	18	28	-456	
59	1	22	144	280/	1	4	-36	-152	
61	1	-8	-76	536/	1	-16	16	320	
67	1	12	-32	-64/	1	12	28	-40	
71	1	-1/	1	-1/	1	-1/1	-1/1	-1	
73	1	-3	-2	7/	1	-27	202	-461	
79	1	-7	-136	525/	1	3	-44	15	
83	1	-23	172	-419/	1	19	96	63	
89	1	-13	-82	45/	1	-1	-22	-27	
97	1	-4	-36	152/	1	-22	144	-280	
101	1	3	-62	129/	1	-9	22	-15	
103	1	9	-48	-191/	1	7	-152	-53	
107	1	12	-32	-64/	1	-28	192	-64	
109	1	-19	-14	735/	1	1	-26	15	
113	1	0	-260	-1544/	1	8	-12	-72	
127	1	26	60	-1576/	1	-10	-64	-8	
131	1	13	-12	-371/	1	-9	-236	2287	
137	1	22	-48	-1256/	1	-8	-112	320	
139	1	-26	192	-360/	1	-8	-68	-56	
149	1	10	-132	280/	1	4	-84	-392	
151	1	27	196	367/	1	-47	732	-3779	
157	1	7	-30	25/	1	23	-14	-691	
163	1	-10	-72	504/	1	42	508	1816	
167	1	-55	984	-5679/	1	-9	-20	175	
173	1	6	-288	-648/	1	22	92	-216	
179	1	3	-356	-945/	1	1	-124	477	
181	1	-38	376	-888/	1	6	-200	-1176	
191	1	23	-80	-925/	1	-15	-260	-743	
193	1	2	-528	-4824/	1	-12	-132	1304	
197	1	0	-80	-192/	1	20	92	120	
199	1	25	128	185/	1	-37	436	-1657	
211	1	-14	-68	504/	1	38	296	648	
223	1	-5	-312	2479/	1	5	-740	-8911	
227	1	-4	-428	2168/	1	0	-596	-3896	
229	1	-23	-114	1935/	1	-11	-518	-821	
233	1	21	-242	-1777/	1	-7	-346	-1061	
239	1	46	616	1960/	1	-4	-348	200	
241	1	-62	1248	-8136/	1	-36	276	-200	
251	1	-7	-192	1629/	1	-37	324	315	
257	1	12	-380	-200/	1	38	348	360	

Table C

This table gives the Fourier coefficients a_p ($2 \leq p \leq 761$: prime numbers) of a primitive form in $\mathcal{S}_2\left(N, \left(\frac{\cdot}{N}\right)\right)$ for $N = 29$ and 37 . Since the dimension of each space is 2,

$$\left\{ f(z) = \sum_{n=1}^{\infty} a_n e^{2\pi i n z}, f_{\rho}(z) = \sum_{n=1}^{\infty} \bar{a}_n e^{2\pi i n z} \right\}$$

is a basis of $\mathcal{S}_2\left(N, \left(\frac{\cdot}{N}\right)\right)$.

$\mathcal{S}_2\left(29, \left(\frac{\cdot}{29}\right)\right)$

p	$\left(\frac{p}{29}\right)$	a_p	p	$\left(\frac{p}{29}\right)$	a_p	p	$\left(\frac{p}{29}\right)$	a_p
2	-	$\sqrt{-5}$	3	-	$-\sqrt{-5}$	5	+	-3
7	+	2	11	-	$\sqrt{-5}$	13	+	-1
17	-	$-2\sqrt{-5}$	19	-	0	23	+	6
29		$-3+2\sqrt{-5}$	31	-	$3\sqrt{-5}$	37	-	0
41	-	$-2\sqrt{-5}$	43	-	$-3\sqrt{-5}$	47	-	$\sqrt{-5}$
53	+	-9	59	+	6	61	-	$6\sqrt{-5}$
67	+	8	71	+	0	73	-	0
79	-	$-3\sqrt{-5}$	83	+	-6	89	-	$-2\sqrt{-5}$
97	-	$6\sqrt{-5}$	101	-	$-8\sqrt{-5}$	103	+	-4
107	+	18	109	+	5	113	-	$4\sqrt{-5}$
127	-	0	131	-	$4\sqrt{-5}$	137	-	$4\sqrt{-5}$
139	+	-10	149	+	15	151	+	-10
157	-	$-6\sqrt{-5}$	163	-	$-9\sqrt{-5}$	167	+	-12
173	+	-6	179	+	0	181	+	5

$$\mathcal{L}_2\left(29, \left(\frac{\quad}{29}\right)\right)$$

p	$\left(\frac{p}{29}\right)$	a_p	p	$\left(\frac{p}{29}\right)$	a_p	p	$\left(\frac{p}{29}\right)$	a_p
191	-	$4\sqrt{-5}$	193	-	$-6\sqrt{-5}$	197	+	-18
199	+	14	211	-	$3\sqrt{-5}$	223	+	-16
227	+	12	229	-	$-6\sqrt{-5}$	233	+	-9
239	+	6	241	+	-25	251	-	$7\sqrt{-5}$
257	+	-3	263	-	$-5\sqrt{-5}$	269	-	$-2\sqrt{-5}$
271	-	$-9\sqrt{-5}$	277	+	2	281	+	3
283	+	14	293	-	$4\sqrt{-5}$	307	-	$9\sqrt{-5}$
311	-	$4\sqrt{-5}$	313	+	29	317	-	$10\sqrt{-5}$
331	-	$15\sqrt{-5}$	337	-	$-6\sqrt{-5}$	347	+	-12
349	+	-1	353	+	-6	359	-	$\sqrt{-5}$
367	-	$-12\sqrt{-5}$	373	+	-31	379	-	0
383	+	6	389	-	$-8\sqrt{-5}$	397	+	-7
401	+	15	409	-	$12\sqrt{-5}$	419	+	24
421	-	$6\sqrt{-5}$	431	+	18	433	-	0
439	+	-34	443	-	$-8\sqrt{-5}$	449	-	$16\sqrt{-5}$
457	+	2	461	-	$4\sqrt{-5}$	463	+	26
467	-	$\sqrt{-5}$	479	-	$-5\sqrt{-5}$	487	+	2
491	-	$-11\sqrt{-5}$	499	+	-10	503	-	$7\sqrt{-5}$
509	+	15	521	+	-27	523	+	-4
541	-	0	547	+	38	557	+	18
563	-	$-5\sqrt{-5}$	569	-	$-8\sqrt{-5}$	571	+	32
577	-	$-18\sqrt{-5}$	587	+	-42	593	+	9
599	-	$13\sqrt{-5}$	601	-	$6\sqrt{-5}$	607	-	$3\sqrt{-5}$
613	+	-31	617	-	$-20\sqrt{-5}$	619	-	$15\sqrt{-5}$
631	+	32	641	-	$10\sqrt{-5}$	643	+	26
647	+	-18	653	-	$22\sqrt{-5}$	659	-	$-17\sqrt{-5}$
661	+	-10	673	+	11	677	-	$-8\sqrt{-5}$
683	+	-36	691	+	20	701	+	-45
709	+	35	719	+	36	727	-	$-12\sqrt{-5}$
733	-	$12\sqrt{-5}$	739	-	$-9\sqrt{-5}$	743	-	$4\sqrt{-5}$
751	-	$12\sqrt{-5}$	757	-	$-18\sqrt{-5}$	761	+	-30

$$\mathcal{S}_2\left(37, \left(\frac{-}{37}\right)\right)$$

p	$\left(\frac{p}{37}\right)$	a_p	p	$\left(\frac{p}{37}\right)$	a_p	p	$\left(\frac{p}{37}\right)$	a_p
2	-	2i	3	+	-1	5	-	-2i
7	+	3	11	+	-3	13	-	-6i
17	-	2i	19	-	6i	23	-	4i
29	-	-4i	31	-	0	37	-	-1+6i
41	+	-3	43	-	-6i	47	+	3
53	+	9	59	-	-4i	61	-	0
67	+	-12	71	+	-3	73	+	9
79	-	6i	83	+	9	89	-	-14i
97	-	12i	101	+	-3	103	-	-6i
107	+	-12	109	-	6i	113	-	4i
127	+	-7	131	-	-10i	137	+	18
139	+	0	149	+	15	151	+	-8
157	+	3	163	-	-6i	167	-	2i
173	+	-21	179	-	16i	181	+	-3
191	-	20i	193	-	-6i	197	+	3
199	-	-24i	211	+	-13	223	+	19
227	-	-8i	229	+	-5	233	+	-6
239	-	16i	241	-	0	251	-	10i
257	-	-8i	263	+	9	269	+	-30
271	+	-3	277	-	12i	281	-	-20i
283	-	24i	293	+	-6	307	+	-7
311	-	10i	313	-	-6i	317	+	18
331	-	0	337	+	13	347	-	32i
349	+	30	353	-	14i	359	+	-15
367	+	8	373	+	-21	379	+	15
383	-	-16i	389	-	16i	397	+	33
401	-	-10i	409	-	-24i	419	+	15
421	-	30i	431	-	10i	433	+	9
439	-	-24i	443	+	-21	449	-	26i
457	-	-18i	461	-	10i	463	-	-36i
467	-	-28i	479	-	-4i	487	-	-18i
491	+	12	499	-	36i	503	-	14i
509	+	15	521	+	-3	523	-	-6i
541	-	0	547	-	12i	557	-	-28i
563	-	-26i	569	-	-44i	571	+	-33
577	-	42i	587	-	22i	593	+	-21
599	+	45	601	+	-18	607	-	-18i
613	+	29	617	+	3	619	+	-35
631	-	-30i	641	+	-33	643	-	24i
647	-	2i	653	-	44i	659	+	-45
661	-	30i	673	+	-21	677	+	3
683	-	-46i	691	+	12	701	-	20i
709	-	6i	719	+	15	727	-	-18i
733	+	-31	739	+	25	743	+	39
751	+	27	757	-	12i	761	+	-33

References

- Ahlfors, L. (1966) *Complex analysis*, 2nd edition, McGraw-Hill.
- Artin, E. (1923) Über eine neue Art von L -Reihen, *Abh. Math. Sem. Univ. Hamburg* **3**, 89–108.
- Asai, T. (1976) On the Fourier coefficients of automorphic forms at various cusps and some applications to Rankin's convolution, *J. Math. Soc. Japan* **28**, 48–61.
- Atkin, A. O. L., Lehner, J. (1970) Hecke operators on $\Gamma_0(m)$, *Math. Ann.* **185**, 134–160.
- Borevich, Z. I., Shafarevich, I. R. (1966) *Number Theory*, Academic Press.
- Deligne, P. (1968/69) Formes modulaires et représentations l -adiques, *Seminaire Bourbaki* n° 355.
- Deligne, P. (1974) La conjecture de Weil I, *Publ. Math. I.H.E.S.* **43**, 273–307.
- Deligne, P., Serre, J.-P. (1974) Formes modulaires de poids 1, *Ann. Sc. de l'Éc. Norm. Sup.* **7**, 507–530.
- Doi, K., Naganuma, H. (1969) On the functional equation of certain Dirichlet series, *Invent. Math.* **9**, 1–14.
- Eichler, M. (1938) Allgemeine Kongruenzklasseneinteilungen der Ideale einfacher Algebren über algebraischen Zahlkörpern und ihre L -Reihen, *J. Reine Angew. Math.* **179**, 227–251.
- Eichler, M. (1954) Quaternäre quadratische Formen und die Riemannsche Vermutung für die Kongruenzetafunktion, *Arch. Math.* **5**, 355–366.
- Eichler, M. (1956) Über die Darstellbarkeit von Modulformen durch Thetareihen, *J. Reine Angew. Math.* **195**, 156–171.
- Eichler, M. (1957) Eine Verallgemeinerung der Abelschen Integrale, *Math. Z.* **67**, 267–298.
- Fricke-F., Klein, R. (1897, 1912) *Vorlesungen über die Theorie der automorphen Funktionen I, II*, Teubner.
- Gelfand, I. M., Graev, M. I., Pyatetskii-Shapiro, I. I. (1969) *Representation Theory and Automorphic Functions*, Saunders.
- Godement, R. (1957/1958) Où l'on généralise une intégrale étudiée par Siegel et généralisant la fonction Γ , *Fonctions holomorphes de carré sommable dans le demi-plan de Siegel, Generalités sur les formes modulaires I, II*, *Seminaire Henri Cartan* 10e année.
- Godement, R. (1970) Notes on Jacquet–Langlands' theory, *Inst. for Advanced Study*.
- Hasse, H. (1952) Über die Klassenzahl abelscher Zahlkörper, *Akademie-Verlag*.
- Hecke, E. (1918, 1920) Eine neue Art von Zetafunktionen und ihre Beziehungen zur Verteilung der Primzahlen I, II, *Math. Z.* **1**, 357–376; **6**, 11–51 (*Werke* 12, 14).
- Hecke, E. (1936) Über die Bestimmung Dirichletscher Reihen durch ihre Funktionalgleichung, *Math. Ann.* **112**, 664–699 (*Werke* 33).
- Hecke, E. (1937) Über Modulfunktionen und die Dirichletscher Reihen mit Eulerscher Produktentwicklung I, II, *Math. Ann.* **114**, 1–28; 316–351 (*Werke* 35, 36).
- Hijikata, H. (1974) Explicit formula of the traces of Hecke operators for $\Gamma_0(N)$, *J. Math. Soc. Japan* **26**, 56–82.
- Igusa, J. (1959) Kroneckerian model of fields of elliptic modular functions, *Amer. J. Math.* **81**, 561–577.
- Igusa, J. (1972) *Theta Functions*. Springer, Berlin Heidelberg New York.
- Ihara, Y. (1967) Hecke polynomials as congruence ζ functions in elliptic modular case, *Ann. Math.* **85**, 267–295.
- Ishikawa, H. (1973) On the trace formula for Hecke operators, *J. Fac. Sci. Univ. Tokyo* **20**, 217–238.
- Iwasawa, K. (1972) Lectures on p -adic L -function, *Ann. Math. Studies* 74.
- Jacquet, H., Langlands, R. P. (1970) *Automorphic Forms on $GL(2)$* , *Lecture Notes in Mathematics* **114**, Springer, Berlin Heidelberg New York.

- Kuga, M., Shimura, G. (1965) On the zeta-function of a fibre variety whose fibres are abelian varieties, *Ann. Math.* **82**, 478–539.
- Lang, S. (1982) *Introduction to algebraic and abelian functions*, 2nd edition, Springer, Berlin Heidelberg New York.
- Langlands, R. P. (1970) *Problems in the Theory of Automorphic Forms*, *Lectures in modern analysis and applications III*, *Lecture Notes in Mathematics* **170**, Springer, Berlin Heidelberg New York.
- Miyake, T. (1971) On automorphic forms on GL_2 and Hecke operators, *Ann. Math.* **94**, 174–189.
- Naganuma, H. (1973) On the coincidence of two Dirichlet series associated with cusp forms of Hecke's "Neben"-type and Hilbert modular forms over a real quadratic field, *J. Math. Soc. Japan* **25**, 547–555.
- Saito, H. (1972) On Eichler's trace formula, *J. Math. Soc. Japan* **24**, 333–340.
- Selberg, A. (1956) Harmonic analysis and discontinuous groups in weakly symmetric Riemannian spaces with applications to Dirichlet series, *J. Indian Math. Soc.* **20**, 47–87.
- Shimizu, H. (1963) On discontinuous groups operating on the product of the upper half planes, *Ann. Math.* **77**, 33–71.
- Shimizu 2, (1963) On traces of Hecke operators, *J. Fac. Sci. Univ. Tokyo* **10**, 1–19.
- Shimizu 3, (1965) On Zeta Functions of Quaternion Algebras, *Ann. Math.* **81**, 166–193.
- Shimizu 4, (1968) Approximation theorem, Hecke algebras and zeta-functions, *Seminary Notes*, Univ. of Tokyo (in Japanese).
- Shimura, G. (1971) *Introduction to the arithmetic theory of automorphic functions*, Iwanami Shoten and Princeton Univ. Press.
- Shimura 2, (1958) Correspondances modulaires et les fonctions ζ de courbes algébriques, *J. Math. Soc. Japan* **10**, 1–28.
- Shimura 3, (1961) On the zeta-functions of the algebraic curves uniformized by certain automorphic functions, *J. Math. Soc. Japan* **13**, 275–331.
- Shimura 4, (1966) A reciprocity law in non-solvable extensions, *J. Reine Angew. Math.* **221**, 209–220.
- Shimura 5, (1971) On elliptic curves with complex multiplication as factors of the jacobians of modular function fields, *Nagoya Math. J.* **43**, 199–208.
- Shimura 6, (1972) Class fields over real quadratic fields and Hecke operators, *Ann. Math.* **95**, 130–190.
- Shimura 7, (1973) On modular forms of half integral weight, *Ann. Math.* **97**, 440–481.
- Shimura 8, (1975) On some arithmetic properties of modular forms of one and several variables, *Ann. Math.* **102**, 491–515.
- Shimura 9, (1982) Confluent hypergeometric functions on tube domains, *Math. Ann.* **260**, 260–302.
- Shimura 10, (1983) On Eisenstein series, *Duke Math. J.* **50**, 417–476.
- Shimura 11, (1985) On Eisenstein series of half-integral weight, *Duke Math. J.* **52**, 281–314.
- Shimura 12, (1985) On the Eisenstein series of Hilbert modular groups, *Revista mathematica Iberoamericana* **1**, 1–42.
- Shintani, T. (1975) On construction of holomorphic cusp forms of half integral weight, *Nagoya Math. J.* **58**, 83–126.
- Siegel, C. L. *Gesammelte Abhandlungen*, Springer, Berlin Heidelberg New York.
- Siegel 2, (1961) *On Advanced Analytic Number Theory*, Tata Institute.
- Stein, E. M., Weiss, G. (1971) *Introduction to Fourier analysis on Euclidean spaces*, Princeton Univ. Press.
- Vigneras, M.-F. (1980) *Arithmétique des Algèbres de Quaternions*, *Lecture Notes in Mathematics* **800**, Springer, Berlin Heidelberg New York.
- Waldspurger, J.-L. (1982) Sur les coefficients de Fourier des formes modulaires de poids demi-entier, *J. Math. pures et appl.* **60**, 375–484.
- Washington, L. C. (1982) *Introduction to cyclotomic fields*, Springer, Berlin Heidelberg New York.
- Weil, A. (1967) *Basic Number Theory*, Springer, Berlin Heidelberg New York.
- Weil 2, (1971) *Dirichlet series and automorphic forms*, *Lecture Notes in Mathematics* **189**, Springer, Berlin Heidelberg New York.
- Weil 3, (1967) Über die Bestimmung Dirichletscher Reihen durch Funktionalgleichungen, *Math. Ann.* **168**, 149–156.
- Weil 4, (1968) Sur une formule classique, *J. Math. Soc. Japan* **20**, 400–402.
- Weil 5, (1965) *L'intégration dans les groupes topologiques et ses applications*, Hermann.
- Yoshida, K. (1971) *Functional analysis*, Springer, Berlin Heidelberg New York.

List of Symbols

§1.1		Page
\mathbb{P}	the Riemann sphere ($= \mathbb{R} \cup \{\infty\}$)	1
\mathbf{H}	the upper half plane ($= \{z \in \mathbb{C} \mid \text{Im}(z) > 0\}$)	2
\mathbf{K}	the unit disk ($= \{z \in \mathbb{C} \mid z < 1\}$)	2
$\text{Aut}(\mathbf{H})$	the group of automorphisms of \mathbf{H}	2
$\text{Aut}(\mathbf{K})$	the group of automorphisms of \mathbf{K}	2
αz	$= (az + b)/(cz + d) \quad \left(\alpha = \begin{bmatrix} a & b \\ c & d \end{bmatrix} \right)$	1 (1.1.1)
$j(\alpha, z)$	$= cz + d \quad \left(\alpha = \begin{bmatrix} a & b \\ c & d \end{bmatrix} \right)$	1 (1.1.2)
$GL_2^+(\mathbb{R})$	$= \{\alpha \in GL_2(\mathbb{R}) \mid \det(\alpha) > 0\}$	3
$SO_2(\mathbb{R})$	$= \left\{ \begin{bmatrix} \cos \theta & \sin \theta \\ -\sin \theta & \cos \theta \end{bmatrix} \mid 0 \leq \theta < 2\pi \right\}$	3
$SU(1, 1)$	$= \left\{ g \in SL_2(\mathbb{C}) \mid {}^t \bar{g} \begin{bmatrix} 1 & 0 \\ 0 & -1 \end{bmatrix} g = \begin{bmatrix} 1 & 0 \\ 0 & -1 \end{bmatrix} \right\}$	4
§1.2		
G_x	the stabilizer of x ($= \{g \in G \mid gx = x\}$)	5
Gx	$= \{gx \mid g \in G\}$	5
$G \backslash X$	the quotient space of X by G	5
G/K	the space of the right cosets of G by K	6
§1.3		
$GL_2^+(\mathbb{R})_x^{(p)}$	$= \{\alpha \in GL_2^+(\mathbb{R})_x \mid \alpha \text{ is parabolic or scalar}\}$	7 (1.3.1)
$SL_2(\mathbb{R})_x^{(p)}$	$= SL_2(\mathbb{R}) \cap GL_2^+(\mathbb{R})_x^{(p)}$	7 (1.3.1)
$GL_2^+(\mathbb{R})_{x,x'}$	$= GL_2^+(\mathbb{R})_x \cap GL_2^+(\mathbb{R})_{x'}$	7 (1.3.2)
$SL_2(\mathbb{R})_{x,x'}$	$= SL_2(\mathbb{R}) \cap GL_2^+(\mathbb{R})_{x,x'}$	7 (1.3.2)
$Z(\alpha)$	the centralizer of α ($= \{\beta \in GL_2(\mathbb{R}) \mid \alpha\beta = \beta\alpha\}$)	9 (1.3.3)
$N(G)$	the normalizer of G ($= \{\alpha \in GL_2(\mathbb{R}) \mid \alpha G \alpha^{-1} = G\}$)	9 (1.3.4)
§1.4		
$(f \circ \alpha)(z)$	$= f(\alpha z)$	10

df	$= \left(\frac{\partial f}{\partial x}\right)dx + \left(\frac{\partial f}{\partial y}\right)dy$	10
$df \circ \alpha$	$= d(f \circ \alpha)$	10
dz	$= dx + idy \quad (z = x + iy)$	10 (1.4.1)
$d\bar{z}$	$= dx - idy \quad (z = x + iy)$	10 (1.4.1)
$ds^2(z)$	$= (dx^2 + dy^2)/y^2 \quad (z = x + iy \in \mathbf{H})$	11 (1.4.2)
$ds_{\mathbf{K}}^2(w)$	$= 4(dx^2 + dy^2)/(1 - w ^2)^2 \quad (w = x + iy \in \mathbf{K})$	11
$dv(z)$	$= dx dy / y^2 \quad (z = x + iy \in \mathbf{H})$	11 (1.4.2)
$dv_{\mathbf{K}}(w)$	$= 4dxdy/(1 - w ^2)^2 \quad (w = x + iy \in \mathbf{K})$	11
$d\alpha$	Haar measure of $SL_2(\mathbb{R}) \quad (= (2\pi)^{-1}y^{-2}dxdy d\theta)$	16 (1.4.13)
$v(D)$	$= \int_D dv(z) \quad (D \subset \mathbf{H})$	13
$d(\cdot, \cdot)$	the distance in \mathbf{H}	12
h_z	$= \sqrt{y}^{-1} \begin{bmatrix} y & x \\ 0 & 1 \end{bmatrix} \quad (z = x + iy \in \mathbf{H})$	15 (1.4.8)
k_θ	$= \begin{bmatrix} \cos \theta & \sin \theta \\ -\sin \theta & \cos \theta \end{bmatrix} \quad (\theta \in \mathbb{R})$	15 (1.4.9)

§1.5

$Z(\Gamma)$	$= \Gamma \cap \{\pm 1\}$	18
Γ_z	$= \Gamma \cap SL_2(\mathbb{R})_z \quad (z \in \mathbf{H} \cup \mathbb{R} \cup \{\infty\})$	18
$\Gamma_{x, x'}$	$= \Gamma \cap SL_2(\mathbb{R})_{x, x'} \quad (x, x' \in \mathbb{R} \cup \{\infty\})$	18
e_z	the order of $z = \Gamma_z / Z(\Gamma) \quad (z \in \mathbf{H}), = \infty \quad (z: \text{a cusp})$	19

§1.6

F_γ	$= \{z \in \mathbf{H} \mid d(z, z_0) \leq d(z, \gamma z_0)\}$	21
U_γ	$= \{z \in \mathbf{H} \mid d(z, z_0) < d(z, \gamma z_0)\}$	21
C_γ	$= \{z \in \mathbf{H} \mid d(z, z_0) = d(z, \gamma z_0)\}$	21

§1.7

P_Γ	the set of cusps of Γ	25
$\mathbf{H}^*, \mathbf{H}_\Gamma^*$	$= \mathbf{H} \cup P_\Gamma$	25 (1.7.1)
$\Gamma \backslash \mathbf{H}$	the quotient space of \mathbf{H} by Γ	25
$\Gamma \backslash \mathbf{H}^*$	the quotient space of \mathbf{H}^* by Γ	25
π, π_Γ	the natural mapping of \mathbf{H}^* onto $\Gamma \backslash \mathbf{H}^*$	27
U_l	$= \{z \in \mathbf{H} \mid \text{Im}(z) > l\}$	25 (1.7.2)
U_l^*	$= U_l \cup \{\infty\}$	25 (1.7.2)

§1.8

(V_α, t_α)	a local chart	28
$\{(V_\alpha, t_\alpha)\}$	a coordinate system of a Riemann surface	28
\mathfrak{R}	a Riemann surface	28

		Page
$K(\mathfrak{R})$	the function field of \mathfrak{R}	30
(\mathfrak{R}', F)	a covering of a Riemann surface	31
$e_{b,F}$	the ramification index of a covering F at b	31
\mathfrak{R}_F	$= \Gamma \setminus \mathbf{H}^*$ (as a Riemann surface)	30
V_a	a neighborhood of $a \in \Gamma \setminus \mathbf{H}^*$	28
e_a	the ramification index of $a \in \mathfrak{R}_F$	30 (1.8.3)
$v_a(\phi)$	the order of ϕ at a	30 (1.8.4)
$n_0(\phi)$	$= \sum_{v_a(\phi) > 0} v_a(\phi)$ ($K(\mathfrak{R}) \ni \phi$: non-constant)	30 (1.8.5)
$n_x(\phi)$	$= \sum_{v_a(\phi) < 0} v_a(\phi) $ ($K(\mathfrak{R}) \ni \phi$: non-constant)	30 (1.8.5)
§1.9		
$C_c(X)$	the space of continuous functions on X with compact support	31
§2.1		
$(f _k \alpha)(z)$	$= \det(\alpha)^{k/2} j(\alpha, z)^{-k} f(\alpha z)$	37 (2.1.5)
(f, g)	the Petersson inner product	
	$\left(= v(\Gamma \setminus \mathbf{H})^{-1} \int_{\Gamma \setminus \mathbf{H}} f(z) \overline{g(z)} \operatorname{Im}(z)^k dv(z) \right)$	44 (2.1.32)
Γ_χ	$= \operatorname{Ker}(\chi)$ (χ : a character of Γ)	43
$\Omega_k(\Gamma)$	the space of automorphic forms of weight k with respect to Γ	38
$\mathcal{A}_k(\Gamma)$	$= \{ f \in \Omega_k(\Gamma) \mid f: \text{meromorphic} \}$	40
$\mathcal{G}_k(\Gamma)$	$= \{ f \in \Omega_k(\Gamma) \mid f: \text{holomorphic} \}$	40
$\mathcal{S}_k(\Gamma)$	$= \{ f \in \Omega_k(\Gamma) \mid f: \text{cusp form} \}$	40
$\mathcal{N}_k(\Gamma)$	$= \{ f \in \mathcal{G}_k(\Gamma) \mid (f, g) = 0 \text{ for any } g \in \mathcal{S}_k(\Gamma) \}$	44
$\Omega_k(\Gamma, \chi)$	$= \{ f \in \Omega_k(\Gamma_\chi) \mid f _k \gamma = \chi(\gamma) f \text{ for any } \gamma \in \Gamma \}$	43
$\mathcal{A}_k(\Gamma, \chi)$	$= \Omega_k(\Gamma, \chi) \cap \mathcal{A}_k(\Gamma_\chi)$	43
$\mathcal{G}_k(\Gamma, \chi)$	$= \Omega_k(\Gamma, \chi) \cap \mathcal{G}_k(\Gamma_\chi)$	43
$\mathcal{S}_k(\Gamma, \chi)$	$= \Omega_k(\Gamma, \chi) \cap \mathcal{S}_k(\Gamma_\chi)$	43
$\mathcal{N}_k(\Gamma, \chi)$	$= \{ f \in \mathcal{G}_k(\Gamma, \chi) \mid (f, g) = 0 \text{ for any } g \in \mathcal{S}_k(\Gamma, \chi) \}$	44
$\Omega(\Gamma)$	$= \sum_{k=-\infty}^{\infty} \Omega_k(\Gamma)$	38
$\mathcal{A}(\Gamma)$	$= \sum_{k=-\infty}^{\infty} \mathcal{A}_k(\Gamma)$	40
$\mathcal{G}(\Gamma)$	$= \sum_{k=-\infty}^{\infty} \mathcal{G}_k(\Gamma)$	40
$\mathcal{S}(\Gamma)$	$= \sum_{k=-\infty}^{\infty} \mathcal{S}_k(\Gamma)$	40
§2.2		
$\{(\phi_\mu, V_\mu, t_\mu)\}$	a differential on a Riemann surface	45
$d\phi$	the differential of $\phi \in K(\mathfrak{R})$ ($= \{(d\phi/dt_\mu, V_\mu, t_\mu)\}$)	46

		Page
$v_a(\omega)$	$= v_a(\phi_\mu) \quad (\omega = \{(\phi_\mu, V_\mu, t_\mu)\} \in D^m(\mathfrak{R}))$	47
$D^m(\mathfrak{R})$	the space of differentials of degree m on \mathfrak{R}	45
$D_0^m(\mathfrak{R})$	$= \{\omega \in D^m(\mathfrak{R}) \mid \omega = 0 \text{ or } \text{div}(\omega) \geq 0\}$	48
$D(\mathfrak{R})$	$= \sum_{m=-\infty}^{\infty} D^m(\mathfrak{R})$	46
$\text{Div}(\mathfrak{R})$	$= \left\{ \sum_{\mathfrak{a} \in \mathfrak{R}} c_a \mathfrak{a} \mid c_a \in \mathbb{Z}, c_a = 0 \text{ for almost all } \mathfrak{a} \right\}$	46
$\text{Div}_l(\mathfrak{R})$	$= \{\text{div}(\phi) \mid \phi \in K(\mathfrak{R})^\times\} \quad (\subset \text{Div}(\mathfrak{R}))$	47
$\text{deg}(\mathfrak{a})$	$= \sum_a c_a \quad (\mathfrak{a} = \sum_a c_a \mathfrak{a} \in \text{Div}(\mathfrak{R}))$	46
$\text{div}(\phi)$	$= \sum_{\mathfrak{a} \in \mathfrak{R}} v_a(\phi) \mathfrak{a} \quad (\phi \in K(\mathfrak{R})^\times)$	47 (2.2.7)
$\text{div}(\omega)$	$= \sum_{\mathfrak{a} \in \mathfrak{R}} v_a(\omega) \mathfrak{a} \quad (\phi \in D^m(\mathfrak{R}))$	47
$L(\mathfrak{a})$	$= \{\phi \in K(\mathfrak{R}) \mid \phi = 0 \text{ or } \text{div}(\phi) + \mathfrak{a} \geq 0\} \quad (\mathfrak{a} \in \text{Div}(\mathfrak{R}))$	47
$l(\mathfrak{a})$	$= \dim_{\mathbb{C}} L(\mathfrak{a}) \quad (\mathfrak{a} \in \text{Div}(\mathfrak{R}))$	47
§2.3		
$\mathcal{A}(\Gamma)_{\text{even}}$	$= \sum_{m=-\infty}^{\infty} \mathcal{A}_{2m}(\Gamma)$	50
$\text{Div}(\mathfrak{R})_{\mathbb{Q}}$	$= \text{Div}(\mathfrak{R}) \otimes_{\mathbb{Z}} \mathbb{Q}$	51
$v_a(f)$	$= \begin{cases} e_a^{-1} \text{ord}_{z=z_0}(f) & (f \in \mathcal{A}_{2m}(\Gamma), \mathfrak{a} = \pi(z_0) \in \mathfrak{R}_f) \\ v_a(f^2)/2 & (f \in \mathcal{A}_{2m+1}(\Gamma)) \end{cases}$	50 52
$\omega_f, \omega(f)$	the differential of an automorphic form f	49
$\text{div}(f)$	$= \sum_{\mathfrak{a} \in \mathfrak{R}_f} v_a(f) \mathfrak{a} \quad (f \in \mathcal{A}_m(\Gamma))$	51
$\text{div}(dz)$	$= - \sum_{\mathfrak{a} \in \mathfrak{R}_f} (1 - e_a^{-1}) \mathfrak{a}$	52 (2.3.16)
§2.5		
$[\mathfrak{a}]$	$= \sum_a [c_a] \mathfrak{a} \quad (\mathfrak{a} = \sum_a c_a \mathfrak{a} \in \text{Div}(\mathfrak{R}_f)_{\mathbb{Q}})$	57
§2.6		
$\ f\ _U$	$= (\int_U f(z) \text{Im}(z)^{k/2} ^p dv(z))^{1/p}$	63
$F_k(z; \phi, \chi, \Lambda, \Gamma)$	a Poincaré series $\left(= \sum_{\gamma \in \Lambda \setminus \Gamma} \overline{\chi(\gamma)} (\phi _k \gamma)(z) \right)$	64 (2.6.2)
$\phi_m(z), \phi_m(z; x, \sigma)$	$= j(\sigma, z)^{-k} e^{2\pi i m \sigma z / h}$	67 (2.6.9)
$g_k^{(m)}(z)$	$= F_k(z; e^{2\pi i m z / h}, \chi, \Gamma_\infty, \Gamma)$	67

		Page
§2.7		
$\Gamma \approx \Gamma'$	$[\Gamma : \Gamma \cap \Gamma'] < \infty$ and $[\Gamma' : \Gamma \cap \Gamma'] < \infty$	69
$\tilde{\Gamma}$	$= \{g \in G \mid g\Gamma g^{-1} \approx \Gamma\}$	69
$\mathcal{R}_K(\Gamma, \Gamma'; \Delta)$	$= \left\{ \sum_{\alpha \in \Delta} c_\alpha \Gamma \alpha \Gamma' \mid c_\alpha \in K, c_\alpha = 0 \text{ for almost all } \alpha \right\}$	70
$\mathcal{R}(\Gamma, \Gamma'; \Delta)$	$= \mathcal{R}_{\mathbb{Z}}(\Gamma, \Gamma'; \Delta)$	70
$\mathcal{R}_K(\Gamma, \Delta)$	$= \mathcal{R}_K(\Gamma, \Gamma; \Delta)$	70
$\mathcal{R}(\Gamma, \Delta)$	$= \mathcal{R}_{\mathbb{Z}}(\Gamma, \Delta)$	70
$\deg(\xi)$	$= \sum_{\alpha} c_\alpha \Gamma \alpha \Gamma' \quad (\xi = \sum_{\alpha} c_\alpha \Gamma \alpha \Gamma' \in \mathcal{R}(\Gamma, \Gamma'))$	73
M^Γ	$= \{m \in M \mid m^\gamma = m \text{ for all } \gamma \in \Gamma\}$	71
$m \Gamma \alpha \Gamma'$	$= \sum_i m^{\alpha_i} \quad (\Gamma \alpha \Gamma' = \coprod_i \Gamma \alpha_i)$	71
$m \xi$	$= \sum_{\alpha} c_\alpha (m \Gamma \alpha \Gamma') \quad (\xi = \sum_{\alpha} c_\alpha \Gamma \alpha \Gamma')$	71
§2.8		
$\tilde{\Gamma}$	$= \{g \in GL_2^+(\mathbb{R}) \mid g\Gamma g^{-1} \approx \tilde{\Gamma}\}$	74
$f \Gamma_1 \alpha \Gamma_2$	$= \det(\alpha)^{k/2-1} \sum_v \overline{\chi(\alpha_v)} f _k \alpha_v \quad (\Gamma_1 \alpha \Gamma_2 = \coprod_v \Gamma_1 \alpha_v)$	74 (2.8.2)
$\text{Div}_0(\mathfrak{R})$	$= \{\mathfrak{a} \in \text{Div}(\mathfrak{R}) \mid \deg(\mathfrak{a}) = 0\}$	77
J_{Γ}	the jacobian variety of \mathfrak{R}_{Γ} ($= \text{Div}_0(\mathfrak{R}_{\Gamma})/\text{Div}_1(\mathfrak{R}_{\Gamma})$)	77
$T(\Gamma \alpha \Gamma)$	the modular correspondence	77 (2.8.3)
§3.1		
χ_0	the principal character	79
$\bar{\chi}$	the complex conjugate of χ ($\bar{\chi}(n) = \overline{\chi(n)}$)	79 (3.1.2)
χ^0	the primitive character associated with χ	80
χ_p	the p -factor of χ ($\chi = \prod_p \chi_p$)	80
$W(\chi)$	the Gauss sum of χ ($= \sum_{a=0}^{m-1} \chi(a) e^{2\pi i a/m}$)	80 (3.1.5)
$\left(\frac{n}{p}\right)$	the Legendre symbol	82 (3.1.7)
$\left(\frac{a}{b}\right)$	the Kronecker symbol	83 (3.1.9)
§3.2		
$\zeta(s)$	the Riemann zeta-function ($= \sum_{n=1}^{\infty} n^{-s}$)	84
$\Gamma(s)$	the gamma function ($= \int_0^{\infty} e^{-t} t^{s-1} dt$)	86
z^s	$= e^{s(\log z + i \arg(z))} \quad (z, s \in \mathbb{C})$	86 (3.2.1)
$A(s)$	$= \pi^{-s/2} \Gamma(s/2) \zeta(s)$	87

		Page
$\theta(z)$	$= \sum_{n=-\infty}^{\infty} e^{2\pi i n^2 z}$ (theta function)	89 (3.2.16)
B_m	m -th Bernoulli number	89

§3.3

r_F	the ring of integers of F	91
I	the ideal group	91
P	$= \{a \in I \mid a \in F^\times\}$	91
$I(\mathfrak{m})$	$= \{a \in I \mid (a, \mathfrak{m}) = 1\}$	91
$P(\mathfrak{m})$	$= \{a \in P \mid a \equiv 1 \pmod{\mathfrak{m}}\}$	91
$h(F)$	the class number of $F (= I/P)$	91
$N(\mathfrak{a}), N_F(\mathfrak{a})$	the norm of $\mathfrak{a} \in I$	91
ξ^0	the primitive Hecke character associated with ξ	91
$\bar{\xi}$	the complex conjugate of ξ ($\bar{\xi}(\mathfrak{a}) = \xi(\mathfrak{a})$)	92
$L(s, \xi)$	the Hecke L -function ($= \sum_{\mathfrak{a}} \xi(\mathfrak{a}) N(\mathfrak{a})^{-s}$)	91 (3.3.3)
$L(s, \chi)$	the Dirichlet L -function ($= \sum_{n=1}^{\infty} \chi(n) n^{-s}$)	93 (3.3.13)
$L_N(s, \chi)$	$= \sum_{\substack{n=1 \\ (n, N)=1}}^{\infty} \chi(n) n^{-s}$	93
$\zeta_F(s)$	the Dedekind zeta-function of $F (= \sum_{\mathfrak{a}} N(\mathfrak{a})^{-s})$	92 (3.3.5)
$\mathfrak{D} = \mathfrak{D}(F)$	the different of F	92
d_F	the discriminant of F	92
$\xi_{\alpha}(a)$	$= \prod_{v=1}^{r_1+r_2} (a_v/ a_v)^{u_v} a_v ^{iv_v} \quad (a \in F^\times)$	92 (3.3.6)
$\xi_f(a)$	$= \xi((a)) \xi_{\alpha}(a)^{-1} \quad (a \in F^\times)$	92 (3.3.7)
$W(\xi)$	the Gauss sum of ξ	

$$\left(= \xi_{\alpha}(b) \xi(c)^{-1} \sum_{a \in \mathfrak{c}/\mathfrak{m}\mathfrak{c}} \xi_f(a) e^{2\pi i \text{tr}(a/b)} \right) \tag{3.3.8}$$

$T(\xi)$	$= 2^{iv} i^{-u} W(\xi) / N(\mathfrak{m})^{1/2}$	93
$A(s, \xi)$	$= \left(\frac{2^{r_1} d_F N(\mathfrak{m})^{s/2}}{(2\pi)^g} \prod_{v=1}^{r_1+r_2} \Gamma\left(\frac{n_v(s + iv_v) + u_v }{2}\right) \right) L(s, \xi)$	93 (3.3.12)

$B_{n, \chi}$ the generalized Bernoulli number 94

$$\delta_{\chi} = \begin{cases} 0 & (\chi(-1) = 1) \\ 1 & (\chi(-1) = -1) \end{cases} \tag{3.3.15}$$

§4.1

$$E_k(z) = \sum_{\substack{m, n = -\infty \\ (m, n) \neq (0, 0)}}^{\infty} (mz + n)^{-k} \tag{4.1.3}$$

	Page
$G_k(z)$	$= F_k(z; 1, \chi_0, SL_2(\mathbb{Z})_x, SL_2(\mathbb{Z}))$ 99 (4.1.4)
	$= \frac{1}{2} \sum_{\substack{m, n \in \mathbb{Z} \\ (m, n) = 1}} (mz + n)^{-k}$ 99 (4.1.5)
$g_2(z)$	$= 60E_4(z)$ 101 (4.1.16)
$g_3(z)$	$= 140E_6(z)$ 101 (4.1.16)
$A(z)$	$= 12^{-3}(G_4(z)^3 - G_6(z)^2)$ 101 (4.1.14)
	$= (2\pi)^{-12}(g_2(z)^3 - 27g_3(z)^2)$ 101 (4.1.17)
$J(z)$	$= G_4(z)^3/A(z)$ 101 (4.1.15)
	$= 12^3(2\pi)^{-12}g_2(z)^3/\Delta(z)$ 101 (4.1.18)

§4.2

$\Gamma_0(N)$	$= \left\{ \begin{bmatrix} a & b \\ c & d \end{bmatrix} \in SL_2(\mathbb{Z}) \mid c \equiv 0 \pmod{N} \right\}$ 103
$\Gamma_1(N)$	$= \left\{ \begin{bmatrix} a & b \\ c & d \end{bmatrix} \in SL_2(\mathbb{Z}) \mid c \equiv 0, a \equiv d \equiv 1 \pmod{N} \right\}$ 103
$\Gamma(N)$	$= \left\{ \begin{bmatrix} a & b \\ c & d \end{bmatrix} \in SL_2(\mathbb{Z}) \mid b \equiv c \equiv 0, a \equiv d \equiv 1 \pmod{N} \right\}$ 103
$\Gamma_0^+(N)$	$= \Gamma_0(N) \cup \Gamma_0(N) \begin{bmatrix} -1 & 0 \\ 0 & 1 \end{bmatrix}$ 109
$\Gamma(1)_\infty^+$	$= \left\{ \begin{bmatrix} 1 & n \\ 0 & 1 \end{bmatrix} \in SL_2(\mathbb{Z}) \mid n \in \mathbb{Z} \right\}$ 107 (4.2.4)
$\bar{\Gamma}$	the image of Γ in $\text{Aut}(\mathbf{H})$ 106
$\lambda_N(\gamma)$	$= \gamma \pmod{N}$ 104
$\nu_2(\Gamma)$	the number of inequivalent elliptic points of Γ of order 2 107
$\nu_3(\Gamma)$	the number of inequivalent elliptic points of Γ of order 3 107
$\nu_\infty(\Gamma)$	the number of inequivalent cusps of Γ 107

§4.3

$\chi(\gamma)$	$= \chi(d) \quad \left(\gamma = \begin{bmatrix} a & b \\ c & d \end{bmatrix} \in \Gamma_0(N) \right)$ 114 (4.3.2)
$\mathcal{G}_k(N, \chi)$	$= \mathcal{G}_k(\Gamma_0(N), \chi)$ 115
$\mathcal{L}_k(N, \chi)$	$= \mathcal{L}_k(\Gamma_0(N), \chi)$ 115
$\mathcal{N}_k(N, \chi)$	$= \mathcal{N}_k(\Gamma_0(N), \chi)$ 115
$\omega_N, \omega(N)$	$= \begin{bmatrix} 0 & -1 \\ N & 0 \end{bmatrix}$ 115

		Page
$f_\rho(z)$	$= \sum_{n=0}^{\infty} \bar{a}_n e^{2\pi i n z} \quad \left(f(z) = \sum_{n=0}^{\infty} a_n e^{2\pi i n z} \right)$	115 (4.3.3)
$f_\psi(z)$	$= \sum_{n=0}^{\infty} \psi(n) a_n e^{2\pi i n z} \quad \left(f(z) = \sum_{n=0}^{\infty} a_n e^{2\pi i n z} \right)$	123 (4.3.17)
$L(s; f)$	$= \sum_{n=1}^{\infty} a_n n^{-s} \quad \left(f(z) = \sum_{n=0}^{\infty} a_n e^{2\pi i n z} \right)$	119 (4.3.11)
$L(s; f, \psi)$	$= \sum_{n=1}^{\infty} \psi(n) a_n n^{-s} \quad \left(f(z) = \sum_{n=0}^{\infty} a_n e^{2\pi i n z} \right)$	123 (4.3.18)
$A_N(s; f)$	$= (2\pi/\sqrt{N})^{-s} \Gamma(s) L(s; f)$	119 (4.3.12)
$A_N(s; f, \psi)$	$= (2\pi/m\sqrt{N})^{-s} \Gamma(s) L(s; f, \psi)$	123 (4.3.19)
§4.4		
$\eta(z)$	the Dedekind η -function $\left(= e^{\pi i z/12} \prod_{n=1}^{\infty} (1 - e^{2\pi i n z}) \right)$	129
§4.5		
$\Delta_0(N)$	$= \left\{ \begin{bmatrix} a & b \\ c & d \end{bmatrix} \in M_2(\mathbb{Z}) \mid c \equiv 0 \pmod{N}, (a, N) = 1, ad - bc > 0 \right\}$	132 (4.5.1)
$\Delta_0^*(N)$	$= \left\{ \begin{bmatrix} a & b \\ c & d \end{bmatrix} \in M_2(\mathbb{Z}) \mid c \equiv 0 \pmod{N}, (d, N) = 1, ad - bc > 0 \right\}$	132 (4.5.2)
$\Delta_1(N)$	$= \left\{ \begin{bmatrix} a & b \\ c & d \end{bmatrix} \in M_2(\mathbb{Z}) \mid c \equiv 0, a \equiv 1 \pmod{N}, ad - bc > 0 \right\}$	151
$\mathcal{R}(N)$	$= \mathcal{R}(\Gamma_0(N), \Delta_0(N))$	132 (4.5.4)
$\mathcal{R}^*(N)$	$= \mathcal{R}(\Gamma_0(N), \Delta_0^*(N))$	132 (4.5.5)
$\chi(\alpha)$	$= \overline{\chi(a)} \quad \left(\alpha = \begin{bmatrix} a & b \\ c & d \end{bmatrix} \in \Delta_0(N) \right)$	134 (4.5.8)
$\chi^*(\alpha)$	$= \chi(d) \quad \left(\alpha = \begin{bmatrix} a & b \\ c & d \end{bmatrix} \in \Delta_0^*(N) \right)$	134 (4.5.10)
$f \Gamma_0(N) \alpha \Gamma_0(N)$	$= \begin{cases} \det(\alpha)^{k/2-1} \sum_v \overline{\chi(\alpha_v)} f _k \alpha_v & 134 (4.5.9) \\ (f \in \mathcal{G}_k(N, \chi), \Gamma_0(N) \alpha \Gamma_0(N) = \coprod_v \Gamma_0(N) \alpha_v \in \mathcal{R}(N)) \end{cases}$	
	$= \begin{cases} \det(\alpha)^{k/2-1} \sum_v \overline{\chi^*(\alpha_v)} f _k \alpha_v & 134 (4.5.11) \\ (f \in \mathcal{G}_k(N, \chi), \Gamma_0(N) \alpha \Gamma_0(N) = \coprod_v \Gamma_0(N) \alpha_v \in \mathcal{R}^*(N)) \end{cases}$	
$T(l, m)$	$= \Gamma_0(N) \begin{bmatrix} l & 0 \\ 0 & m \end{bmatrix} \Gamma_0(N) \in \mathcal{R}(N)$	135 (4.5.14)
$T^*(m, l)$	$= \Gamma_0(N) \begin{bmatrix} m & 0 \\ 0 & l \end{bmatrix} \Gamma_0(N) \in \mathcal{R}^*(N)$	135 (4.5.15)

	Page
$T(n) = \sum_{\substack{\alpha \in A_0(N) \\ \det(\alpha) = n}} \Gamma_0(N) \alpha \Gamma_0(N) \in \mathcal{R}(N)$	135 (4.5.14)

$T^*(n) = \sum_{\substack{\alpha \in A_0^*(N) \\ \det(\alpha) = n}} \Gamma_0(N) \alpha \Gamma_0(N) \in \mathcal{R}^*(N)$	135 (4.5.15)
--	--------------

$(f T(n))(z) = n^{k-1} \sum_{\substack{0 < d n \\ ad=n}} \sum_{b=0}^{d-1} \chi(a) d^{-k} f\left(\frac{az+b}{d}\right) \quad (f \in \mathcal{S}_k(N, \chi))$	142 (4.5.26)
---	--------------

$(f T(l, l))(z) = l^{k-2} \chi(l) f(z) \quad (f \in \mathcal{S}_k(N, \chi))$	143 (4.5.27)
--	--------------

§4.6

$\delta_l = \begin{bmatrix} l & 0 \\ 0 & 1 \end{bmatrix}$	153 (4.6.1)
---	-------------

$(f _k \delta_l)(z) = l^{k/2} f(lz)$	153 (4.6.2)
--------------------------------------	-------------

$\mathcal{S}_k^1(N, \chi) = \langle f(lz) \mid f \in \mathcal{S}_k(M, \chi), lM N, M \neq N \rangle$	162
--	-----

$\mathcal{S}_k^0(N, \chi) = \{f \in \mathcal{S}_k(N, \chi) \mid (f, g) = 0 \text{ for any } g \in \mathcal{S}_k^1(N, \chi)\}$	162
---	-----

N_p	166
-------	-----

$\gamma_q \equiv \begin{cases} \begin{bmatrix} 0 & -1 \\ 1 & 0 \end{bmatrix} \pmod{N_q^2} \\ \begin{bmatrix} 1 & 0 \\ 0 & 1 \end{bmatrix} \pmod{(N/N_q)^2} \end{cases} \quad (\gamma_q \in SL_2(\mathbb{Z}))$	166 (4.6.19)
---	--------------

$\gamma'_q \equiv \begin{cases} \begin{bmatrix} 1 & 0 \\ 0 & 1 \end{bmatrix} \pmod{N_q^2} \\ \begin{bmatrix} 0 & -1 \\ 1 & 0 \end{bmatrix} \pmod{(N/N_q)^2} \end{cases} \quad (\gamma'_q \in SL_2(\mathbb{Z}))$	167 (4.6.20)
---	--------------

$\eta_q, \eta_q^{(N)} = \gamma_q \begin{bmatrix} N_q & 0 \\ 0 & 1 \end{bmatrix}$	167 (4.6.21)
--	--------------

$\eta'_q = \gamma'_q \begin{bmatrix} N/N_q & 0 \\ 0 & 1 \end{bmatrix}$	167 (4.6.21)
--	--------------

§4.7

$f_k(z; \chi_1, \chi_2) = a_0 + \sum_{n=1}^{\infty} \left(\sum_{0 < d n} \chi_1(n/d) \chi_2(d) d^{k-1} \right) e^{2\pi i n z}$	177 (4.7.6)
---	-------------

$\mathcal{E}_k(N, \chi) = \langle f_k(lz; \chi_1, \chi_2) \mid lM_1 M_2 N, \chi_1 \chi_2 = \chi \rangle$	179 (4.7.17)
--	--------------

$\mathcal{E}_k(\Gamma_1(N)) = \bigoplus_x \mathcal{E}_k(N, \chi)$	180 (4.7.19)
---	--------------

		Page
§4.8		
$f(z; \xi)$	$= \begin{cases} \sum_{\mathfrak{a}} \xi(\mathfrak{a}) N_{\mathfrak{K}}(\mathfrak{a})^{u/2} e^{2\pi i N_{\mathfrak{K}}(\mathfrak{a})z} & (K: \text{imaginary}) \\ \sum_{\mathfrak{a}} \xi(\mathfrak{a}) e^{2\pi i N_{\mathfrak{K}}(\mathfrak{a})z} & (K: \text{real}) \end{cases}$	183 184
§4.9		
$e(z)$	$= e^{2\pi iz}$	185
A	a positive symmetric matrix in $M_r(\mathbb{Z})$	186
P	a spherical function with respect to A	186
Δ_A	$= \sum_{i,j=1}^r b_{ij} \partial^2 / \partial x_i \partial x_j \quad (A^{-1} = [b_{ij}])$	186
$A[x]$	$= {}^t x A x \quad (x \in \mathbb{C}^r)$	186
$a(n, A)$	$= \# \{m \in \mathbb{Z}^r \mid A[m] = n\}$	186
$a(n, h, A, N, P)$	$= \sum_{\substack{A[m]=n \\ m \equiv h \pmod{N}}} P(m)$	187
$\theta(z; h, A, N, P)$	$= \sum_{\substack{m \in \mathbb{Z}^r \\ m \equiv h \pmod{N}}} P(m) e\left(\frac{A[m]}{2N^2} z\right)$	186 (4.9.3)
$\theta(z, x)$	$= \sum_{m \in \mathbb{Z}^r} e\left(\frac{A[m+x]}{2} z\right)$	187 (4.9.6)
$\theta_{\psi}(z)$	$= \sum_{m=-\infty}^{\infty} \psi(m) m^{\nu} e(m^2 z) \quad (\nu = \delta_{\psi})$	194
ε_d	$= \begin{cases} 1 & (d \equiv 1 \pmod{4}) \\ i & (\text{otherwise}) \end{cases}$	190
$J(\gamma, z)$	$= \left(\frac{c}{d}\right) \varepsilon_d^{-1} (cz+d)^{1/2} \quad \left(\gamma = \begin{bmatrix} a & b \\ c & d \end{bmatrix} \in \Gamma_0(4)\right)$	194
§5.1		
$\text{ord}_p(a)$	$= \max\{m \in \mathbb{Z} \mid a \in p^m \mathbb{Z}_p\} \quad (a \in \mathbb{Q}_p^{\times})$	196
$ a _p$	$= \begin{cases} p^{-\text{ord}_p(a)} & (a \neq 0) \\ 0 & (a = 0) \end{cases} \quad (a \in \mathbb{Q}_p)$	196
$ a _{\infty}$	$= a \quad (a \in \mathbb{Q}_{\infty} = \mathbb{R})$	196
$ a _A$	$= \prod_v a_v _v \quad (a = (a_v) \in \mathbb{Q}_A^{\times})$	197
$Z(B)$	the center of $B (= \{\beta \in B \mid \alpha\beta = \beta\alpha \text{ for any } \alpha \in B\})$	195
B_p	$= B \otimes_{\mathbb{Q}} \mathbb{Q}_p$	196
R_p	the closure of R in B_p	196
\mathbb{Q}_A	the adèle ring of \mathbb{Q}	197
B_A	the adèlization of $B (= B \otimes_{\mathbb{Q}} \mathbb{Q}_A)$	197 (5.1.2)
\mathbb{Q}_A^{\times}	the idele group of \mathbb{Q}	197
B_A^{\times}	the adèlization of B^{\times}	198 (5.1.4)

		Page
§5.2		
N_B	the (reduced) norm of B	200
tr_B	the (reduced) trace of B	200
$f(X; \beta)$	the principal polynomial of β	200
$B_A^{(1)}$	$= \{ \beta \in B_A^\times \mid N_B(\beta) _A = 1 \}$	201
Γ_R	$= \{ \beta \in R^\times \mid N_B(\beta) = 1 \} \quad (\subset GL_2^+(\mathbb{R}))$	209 (5.2.11)
§5.3		
d_B	the discriminant of B	211
U_R	$= GL_2^+(\mathbb{R}) \times \prod_p R_p^\times$	212 (5.3.2)
D_p	$= \left\{ \begin{array}{l} \{g \in R_p \mid N_B(g) \neq 0\} \quad (p \nmid N) \\ \left\{ \left[\begin{array}{cc} a & b \\ p^e c & d \end{array} \right] \in R_p \mid a \in \mathbb{Z}_p^\times, ad - p^e bc \neq 0 \right\} \quad (p \mid N) \end{array} \right.$	213 (5.3.4)
D_R	$= (GL_2^+(\mathbb{R}) \times \prod_p D_p) \cap B_A^\times$	212 (5.3.3)
Δ_R	$= R \cap D_R$	213 (5.3.5)
$\chi(g)$	$= \prod_{p \mid N} \bar{\chi}_p(a_p) \quad \left(g = (g_v) \in D_R, g_p = \begin{bmatrix} a_p & b_p \\ c_p & d_p \end{bmatrix} \right)$	214 (5.3.6)
$T(n)$	$= \sum_{\substack{N_B(\alpha) = n \\ \alpha \in \Delta_R}} \Gamma_R \alpha \Gamma_R \in \mathcal{R}(\Gamma_R, \Delta_R)$	217 (5.3.12)
$T(n, n)$	$= \Gamma_R n \Gamma_R \in \mathcal{R}(\Gamma_R, \Delta_R)$	217 (5.3.13)
§6.1		
$\ f\ _p$	$= \begin{cases} \left(\int_{\mathbf{H}} f(z) \text{Im}(z)^{k/2} z ^p dv(z) \right)^{1/p} & (1 \leq p < \infty) \\ \text{ess. sup}_{z \in \mathbf{H}} f(z) \text{Im}(z)^{k/2} & (p = \infty) \end{cases}$	219
$L_k^p(\mathbf{H})$	$= \{ f \mid \ f\ _p < \infty \}$	219
$H_k^p(\mathbf{H})$	$= \{ f \in L_k^p(\mathbf{H}) \mid f: \text{holomorphic} \}$	220
$(f, g)_{\mathbf{H}}$	$= \int_{\mathbf{H}} f(z) \overline{g(z)} \text{Im}(z)^k dv(z)$	220 (6.1.1)
$K_k(z_1, z_2)$	the kernel function of $H_k^2(\mathbf{H})$	220
\hat{f}	the Fourier transform of $f \in H_k^2(\mathbf{H})$	222
$G_k(u)$	$= \begin{cases} \int_0^\infty y^{k-2} e^{-\pi u y} dy & (u > 0) \\ 0 & (u \leq 0) \end{cases}$	223

		Page
\hat{H}_k^2	$= \{ \phi \mid \phi(u) = 0 \text{ on } \mathbb{R}_-, \int_{-\infty}^{\infty} \phi(u) ^2 G_k(4u) du < \infty \}$	223
$\langle \varphi, \psi \rangle$	$= \int_0^{\infty} \overline{\varphi(u)} \psi(u) G_k(4u) du$	223
$\hat{\phi}(z)$	$= \int_{-\infty}^{\infty} \phi(u) e^{2\pi iuz} du$	223 (6.1.12)
$\hat{K}_k(u, z_2)$	the Fourier transform of $K_k(z_1, z_2)$	225
§6.2		
$(Kf)(z)$	$= \int_{\mathbf{H}} K_k(z, w) f(w) \operatorname{Im}(w)^k dv(w)$	225 (6.2.1)
$\ f\ _p$	$= \begin{cases} \left(\int_{\mathbf{K}} f(w)(1- w ^2)^{k/2} ^p dv_{\mathbf{K}}(w) \right)^{1/p} & (1 \leq p < \infty) \\ \operatorname{ess. sup}_{w \in \mathbf{K}} f(w)(1- w ^2)^{k/2} & (p = \infty) \end{cases}$	225
$(f, g)_{\mathbf{K}}$	$= \int_{\mathbf{K}} \overline{f(w)} g(w) (1- w ^2)^k dv_{\mathbf{K}}(w)$	226
$L_k^p(\mathbf{K})$	$= \{ f \mid \ f\ _p < \infty \}$	226
$H_k^p(\mathbf{K})$	$= \{ f \in L_k^p(\mathbf{K}) \mid f: \text{holomorphic} \}$	226
§6.3		
$\ f\ _{\Gamma, p}$	$= \begin{cases} \left(\int_{\Gamma \setminus \mathbf{H}} f(z) \operatorname{Im}(z)^{k/2} ^p dv(z) \right)^{1/p} & (1 \leq p < \infty) \\ \operatorname{ess. sup}_{z \in \mathbf{H}} f(z) \operatorname{Im}(z)^{k/2} & (p = \infty) \end{cases}$	228
$L_k^p(\Gamma, \chi)$	$= \{ f \mid \ f\ _{\Gamma, p} < \infty, f _k \gamma = \chi(\gamma) f \text{ for any } \gamma \in \Gamma \}$	228
$H_k^p(\Gamma, \chi)$	$= \{ f \in L_k^p(\Gamma, \chi) \mid f: \text{holomorphic} \}$	228
$(f, g)_{\Gamma}$	$= \int_{\Gamma \setminus \mathbf{H}} \overline{f(z)} g(z) \operatorname{Im}(z)^k dv(z) \quad (f, g \in L_k^2(\Gamma, \chi))$	228
$f^{\Gamma}(z)$	$= Z(\Gamma) ^{-1} \sum_{\gamma \in \Gamma} \overline{\chi(\gamma)} f(\gamma z) j(\gamma, z)^{-k} \quad (f \in L_k^1(\mathbf{H}))$	229 (6.3.2)
$K_k^{\Gamma}(z_1, z_2)$	$= Z(\Gamma) ^{-1} \sum_{\gamma \in \Gamma} \overline{\chi(\gamma)} K_k(\gamma z_1, z_2) j(\gamma, z_1)^{-k}$	229 (6.3.3)

§6.4

$\kappa(z; \alpha)$	$= \det(\alpha)^{k-1} \overline{\chi(\gamma)} K_k(\alpha z, z) j(\alpha, z)^{-k} \text{Im}(z)^k$	231 (6.4.2)
T_x	$= \{\alpha \in T \mid \alpha x = x\}$	232
$Z(T)$	$= T \cap \mathbb{R}^x$	235
T^2	$= \bigcup_{x \in P_\Gamma} (T_x - Z(T))$	235
T^1	$= T - T^2$	235
$\kappa(z; \alpha, s)$	$= \begin{cases} \kappa(z; \alpha) & \left(z \notin \bigcup_x U_x \right) \\ \kappa(z; \alpha) \text{Im}(z)^{-s} j(\sigma_x, z) ^{2s} & \left(z \in \bigcup_x U_x \right) \end{cases}$	235
$g_1 \bar{h} g_2$	g_1 is conjugate to g_2 by an element of H	235
$C_H(g), C_{H, G}(g)$	$= \{g' \in G \mid g \bar{h} g'\}$	235
$M//H$	the set of H -conjugacy classes of M	235
$\Gamma(\alpha)$	$= \{\gamma \in \Gamma \mid \alpha \gamma = \gamma \alpha\}$	235
T^e	$= \{\alpha \in T \mid \alpha \text{ is elliptic}\}$	240
T^h	$= \{\alpha \in T \mid \alpha \text{ is hyperbolic and all fixed points of } \alpha \text{ are cusps}\}$	240
$T^{h'}$	$= \{\alpha \in T \mid \alpha \text{ is hyperbolic and no fixed points of } \alpha \text{ is a cusp}\}$	240
T^p	$= \{\alpha \in T \mid \alpha \text{ is parabolic and the fixed point of } \alpha \text{ is a cusp}\}$	240
$\eta_\alpha, \zeta_\alpha$	the eigen values of α	240
$\text{sgn}(\alpha)$	$= \text{sgn}(\zeta_\alpha)$	240
$m(\alpha, A)$	$= \lambda/h\zeta \left(\sigma \alpha \sigma^{-1} = \begin{bmatrix} \zeta & \lambda \\ 0 & \zeta \end{bmatrix}, \sigma A \sigma^{-1} \{ \pm 1 \} = \left\{ \pm \begin{bmatrix} 1 & h \\ 0 & 1 \end{bmatrix}^m \mid m \in \mathbb{Z} \right\} \right)$	241
$m(\alpha)$	$= m(\alpha, \Gamma(\alpha))$	241
t_0	$= \frac{k-1}{4\pi} \frac{v(\Gamma \backslash \mathbf{H})}{ Z(\Gamma) } \sum_{\alpha \in Z(\Gamma)} \overline{\chi(\alpha)} \text{sgn}(\alpha)^k \det(\alpha)^{k/2-1}$	241
t_e	$= - \sum_{\alpha \in T^e//\Gamma} \frac{\overline{\chi(\alpha)} \eta_\alpha^{k-1}}{ \Gamma(\alpha) \eta_\alpha - \zeta_\alpha}$	241
t_h	$= - \frac{1}{ Z(\Gamma) } \sum_{\alpha \in T^h//\Gamma} \overline{\chi(\alpha)} \text{sgn}(\alpha)^k \frac{\min\{ \eta_\alpha , \zeta_\alpha \}^{k-1}}{ \zeta_\alpha - \eta_\alpha }$	241
t_p	$= \lim_{s \rightarrow +0} \frac{1}{2\pi Z(\Gamma) } \sum_{\alpha \in T^p//\Gamma} \overline{\chi(\alpha)} \text{sgn}(\alpha)^k \det(\alpha)^{k/2-1} (i/m(\alpha))^{1+s}$	241
$k(\alpha)$	$= \begin{cases} \frac{\eta_\alpha^{k-1} - \zeta_\alpha^{k-1}}{\eta_\alpha - \zeta_\alpha} & (\alpha \in T^e), \\ \text{sgn}(\alpha)^k \frac{\min\{ \eta_\alpha , \zeta_\alpha \}^{k-1}}{ \zeta_\alpha - \eta_\alpha } & (\alpha \in T^h), \\ \frac{s}{4} \text{sgn}(\alpha)^k \det(\alpha)^{k/2-1} & (\alpha \in T^p) \end{cases}$	243

$$l(\alpha) = \begin{cases} 1/2|\Gamma(\alpha)| & (\alpha \in T^e), \\ 1/|Z(I)| & (\alpha \in T^h), \\ 1/(|Z(I)| \cdot |m(\alpha)|^{s+1}) & (\alpha \in T^p) \end{cases} \quad 243$$

§6.5

$$\begin{aligned} T_A &= U_R T U_R & 243 \\ T_v &= R_v^x T R_v^x & 248 \\ \mathbb{Z}_A &= \mathbb{R} \times \prod_p \mathbb{Z}_p & 246 \\ R_A &= R \otimes_{\mathbb{Z}} \mathbb{Z}_A & 246 \\ \mathfrak{r}_A &= \mathfrak{r} \otimes_{\mathbb{Z}} \mathbb{Z}_A & 246 \\ \mathfrak{r}_{A^+}^x &= \{(\alpha_v) \in \mathfrak{r}_A^x \mid \det(\alpha_\infty) > 0\} & 246 \\ h(\mathfrak{r}) &= |K_A^x / (\mathfrak{r}_{A^+}^x K^x)| & 246 \end{aligned}$$

$$l(\mathfrak{r}) = \begin{cases} 1/2|\mathfrak{r}^x| & (\alpha \in T^e) \\ 1/2 & (\alpha \in T^h) \\ 1/2|m(\alpha, \mathfrak{r}^x)|^{s+1} & (\alpha \in T^p) \end{cases} \quad 245$$

$$\begin{aligned} C(\alpha), C_{B^*}(\alpha) &= \{\delta\alpha\delta^{-1} \mid \delta \in B^x\} & 244 \\ C_v(\alpha), C_{B_v^*}(\alpha) &= \{x\alpha x^{-1} \mid x \in B_v^x\} & 248 \\ C_A(\alpha), C_{B_A^*}(\alpha) &= \{h\alpha h^{-1} \mid h \in B_A^x\} & 246 \\ C(\alpha, \mathfrak{r}) &= \{\delta\alpha\delta^{-1} \mid \delta \in B^x, \mathbb{Q}[\alpha] \cap \delta^{-1}R\delta = \mathfrak{r}\} & 245 \\ C_p(\alpha, \mathfrak{r}) &= \{x\alpha x^{-1} \mid x \in B_p^x, \mathbb{Q}_p[\alpha] \cap x^{-1}R_p x = \mathfrak{r}_p\} & 248 \\ C_\infty(\alpha, \mathfrak{r}) &= C_\infty(\alpha) & 248 \\ C_A(\alpha, \mathfrak{r}) &= \{h\alpha h^{-1} \mid h \in B_A^x, \mathbb{Q}_A[\alpha] \cap h^{-1}R_A h = \mathfrak{r}_A\} & 246 \end{aligned}$$

§6.6

$$\begin{aligned} R_p &= \left\{ \begin{bmatrix} a & b \\ c & d \end{bmatrix} \in M_2(\mathbb{Z}_p) \mid c \equiv 0 \pmod{p^v} \right\} & 249 \text{ (6.6.3)} \\ \mathcal{N}(R_p) &= \{g \in GL_2(\mathbb{Q}_p) \mid gR_p g^{-1} = R_p\} & 249 \text{ (6.6.4)} \\ f_\alpha(X) &= \text{the principal polynomial of } \alpha (= X^2 - tX + n) & 250 \\ \mathfrak{r}_p &= \text{the order of } \mathbb{Q}_p[\alpha] \text{ including } \mathbb{Z}_p[\alpha] & 250 \\ \rho &= \text{ord}_p([\mathfrak{r}_p : \mathbb{Z}_p[\alpha]]) & 250 \\ \Omega(\alpha, \mathfrak{r}_p) &= \{\xi \in \mathbb{Z}_p \mid f_\alpha(\xi) \equiv 0 \pmod{p^{v+2\rho}}, t \equiv 2\xi \pmod{p^\rho}\} & 250 \text{ (6.6.5)} \\ \Omega'(\alpha, \mathfrak{r}_p) &= \begin{cases} \{\xi \in \mathbb{Z}_p \mid f_\alpha(\xi) \equiv 0 \pmod{p^{v+2\rho+1}}\} & (t^2 \equiv 4n \pmod{p^{2\rho+1}}) \\ \phi & \text{(otherwise)} \end{cases} & 254 \text{ (6.6.12)} \\ \Omega/\rho^{v+\rho} &= \Omega(\alpha, \mathfrak{r}_p) \pmod{p^{v+\rho}} & 254 \\ \Omega'/\rho^{v+\rho+1} &= \Omega'(\alpha, \mathfrak{r}_p) \pmod{p^{v+\rho+1}} & 254 \\ g_\xi &= \begin{bmatrix} \xi & p^\rho \\ -p^{-\rho}f_\alpha(\xi) & t - \xi \end{bmatrix} \quad (\xi \in \Omega(\alpha, \mathfrak{r}_p)) & 250 \text{ (6.6.6)} \end{aligned}$$

	Page
§7.1	
$\Gamma_0(L, M)$	269 (7.1.3)
$E_k(z; \chi, \psi)$	268 (7.1.1)
$E_k(z; \mu, \nu; N)$	271 (7.1.14)
$E_{k,N}^*(z; \chi)$	272 (7.1.27)
$\mathcal{E}_k^{(1)}(\Gamma(N))$	271 (7.1.20)
$\mathcal{E}_k^{(2)}(\Gamma(N))$	271 (7.1.21)
§7.2	
$E_k(z, s; \chi, \psi)$	274 (7.2.1)
$E_k(z, s; \mu, \nu; N)$	289 (7.2.52)
$E_{k,N}^*(z, s; \chi)$	290 (7.2.60)
$E_{k,N}^*(z, s)$	290 (7.2.61)
$E_k(z; \chi, \psi)$	287 (7.2.50)
$E_2(z)$	287 (7.2.51)
$E_k(z; \mu, \nu; N)$	289 (7.2.57)
$E_{k,N}^*(z; \chi)$	290 (7.2.63)
$E_{k,N}^*(z)$	290 (7.2.64)
$\tilde{\mathcal{E}}_k^{(1)}(\Gamma(N))$	289 (7.2.53)
$\tilde{\mathcal{E}}_k^{(2)}(\Gamma(N))$	289 (7.2.54)
$\mathcal{E}_k^{(1)}(\Gamma(N))$	289 (7.2.58)
$\mathcal{E}_k^{(2)}(\Gamma(N))$	289 (7.2.59)

		Page
$S(z; \alpha, \beta)$	$= \sum_{n=-\infty}^{\infty} (z+n)^{-\alpha}(\bar{z}+n)^{-\beta}$	275 (7.2.7)
$\phi(y; \alpha, \beta; x)$	$= (x+iy)^{-\alpha}(x-iy)^{-\beta}$	275 (7.2.9)
$\xi(y; \alpha, \beta; t)$	$= \int_{-\infty}^{\infty} \phi(y; \alpha, \beta; x)e^{-2\pi itx} dx$	275 (7.2.11)
$\sigma(z; \alpha, \beta)$	$= \int_0^{\infty} e^{-zu}(u+1)^{\alpha-1}u^{\beta-1} du$	276 (7.2.16)
$\eta(y; \alpha, \beta; x)$	$= \int_{ t }^{\infty} e^{-yu}(u+t)^{\alpha-1}(u-t)^{\beta-1} du$	276 (7.2.17)
$\omega(z; \alpha, \beta)$	$= \Gamma(\beta)^{-1}z^{\beta}\sigma(z; \alpha, \beta)$	279 (7.2.31)
$A(s)$	$= 2^{k+1}i^{-k}W(\psi^0)(\pi/M)^{s+k}\Gamma(s+k)^{-1}$	285
$B(s)$	$= 2^{1-k}i^{-k}\psi(-1)W(\psi^0)(\pi/M)^s\Gamma(s)^{-1}$	285
$C(s)$	$= \begin{cases} 0 & (\chi = \chi_0) \\ 2L_M(2s+k, \psi) & (\chi \neq \chi_0) \end{cases}$	275 (7.2.6)
$D(s)$	$= \begin{cases} 2i^{-k}\sqrt{\pi} \prod_{p M} (1-p^{-1})\Gamma(s)^{-1}\Gamma(s+k)^{-1}\Gamma\left(\frac{2s+k-1}{2}\right) \\ \times \Gamma\left(\frac{2s+k}{2}\right)L_L(2s+k-1, \chi) & (\psi: \text{trivial}) \\ 0 & (\text{otherwise}) \end{cases}$	284
$a_n(s)$	$= \sum_{0 < c n} \chi(n/c)c^{k+2s-1} \sum_{0 < d (l,c)} d\mu(l/d)\psi^0(l/d)\overline{\psi^0(c/d)}$	285

Subject Index

- Action of
 - a group 4
 - $\Gamma\alpha\Gamma$ on $\mathcal{A}_k(\Gamma, \chi)$ 74
 - $\Gamma\alpha\Gamma'$ on M^Γ 71
 - $\alpha \in GL_2^+(\mathbb{R})$ on a function on \mathbf{H} 37
- Adele ring of \mathbb{Q} 197
- Adelization of
 - an algebra B over \mathbb{Q} 198
 - B 198
- Algebra over a field 195
- Approximation theorem 207
- Artin L -function 185
- Automorphic
 - factor 194
 - form 37
 - form with character 43
 - function field 40
- Automorphy 2

- Bernoulli number 89

- Central algebra 195
- Centralizer 9
- Character mod N 79
- Class
 - character 91
 - number (of an algebraic number field) 91
 - number (of an order) 246
- Commensurable 69
- Complex conjugate of a Dirichlet character 79
- Conductor
 - of a Dirichlet character 80
 - of a Hecke character 91
 - of a primitive form 164
- Confluent hypergeometric function 276
- Conjugate
 - elements of a group are 235
 - exponents are 219
- Coordinate
 - neighborhood 28
 - system 28
- Covering of a Riemann surface 31

- Cusp
 - of Γ 18
 - a point of $\Gamma \backslash \mathbf{H}^*$ is 27
 - form 40
- Dedekind
 - zeta-function 92
 - η -function 129
- Definite quaternion algebra 201
- Degree
 - of a covering 31
 - of a divisor 46
 - of an element of $\mathcal{R}(\Gamma, \Delta)$ 73
- Differential 10
 - of \mathfrak{R} of degree m 45
- Dirichlet
 - L -function 93
 - character 79
 - series 84
 - series associated with a function on \mathbf{H} 119
- Discrete subgroup 17
- Discriminant
 - of a quaternion algebra 211
 - of an algebraic number field 92
- Distance of two points 12
- Division
 - algebra 198
 - quaternion algebra 199
- Divisor
 - class group 47
 - group of \mathfrak{R} 46
 - of a differential 47
 - of a function 47
 - of \mathfrak{R} 46
 - with rational coefficients 51
- Eisenstein
 - series 67, 268
 - series with parameter 274
- Elliptic
 - point 18
 - a point of $\Gamma \backslash \mathbf{H}^*$ is 27
 - matrix 7

- Euler product 85
- Exponent 219
- Fixed point 5
- Formal
 - Dirichlet series 85
 - Euler product 86
- Fourier
 - expansion of an automorphic form at a cusp 40
 - transform of an element of $H_k^2(\mathbf{H})$ 223
- Fuchsian
 - group 18
 - group of the first kind 28
- Full modular group 96
- Function field of a Riemann surface 30
- Fundamental domain 20
- Gamma function 86
- Gauss sum
 - of a Dirichlet character 80
 - of a Hecke character 92
- Generalized Bernoulli number 94
- Genus 31
- Geodesic 11
- Haar
 - measure 15
 - measure of $SL_2(\mathbb{R})$ 16
- Hecke
 - algebra (over K) 72
 - character 91
 - operator 75
- Holomorphic 39
 - at a cusp 39
 - a differential is 48
 - a function on \mathfrak{R} is 30
- Homomorphism of algebras 195
- Hurwitz formula 31
- Hyperbolic
 - matrix 7
 - point 18
- Ideal
 - associated with $a \in \mathbb{Q}$ 197
 - class group 91
- Indefinite quaternion algebra 201
- Induced (Dirichlet character) 79
- Inner automorphism of an algebra 198
- Integral form 40
- Interior angle 23
- Irregular cusp 19
- Jacobian variety 77
- Kernel function 220
- Kronecker symbol 83
- Legendre symbol 82
- Legendre's relation 87
- Level
 - of a congruence modular group 104
 - of an order of Eichler type 211
- Linear fractional transformation 2
- Linked (sides are) 23
- Local
 - chart 28
 - coordinate 28
 - expression of a differential 45
 - field 196
- Maximal order of an algebra 196
- Mellin transform 88
- Meromorphic
 - a function on \mathfrak{R} is 30
 - at a cusp 39
 - automorphic form 40
- Modular
 - correspondence 77
 - form 114
 - function 114
 - group 20, 96
 - group of Hecke type 104
- Modulus 79
- Multiplication in a Hecke ring 71
- Neighborhood of a cusp in \mathbf{H} 25
- Norm
 - of a quaternion algebra 200
 - of an ideal 91
- Normalizer 9
- Orbit (G -orbit) 5
- Order
 - of a point 19
 - of a quaternion algebra 211
 - of an algebra 196
- Ordinary (a point of $\Gamma \backslash \mathbf{H}^*$ is) 27
- Parabolic
 - matrix 7
 - point 18
- Petersson inner product 44
- Phragmen–Lindelöf's Theorem 118
- Poincaré series 64
- Pole of a function on \mathfrak{R} 30
- Positive (a divisor is) 47

Primitive

- Hecke character 91
- character 80
- character associated with a Dirichlet character 80
- form 164

Principal

- character 79
- congruence modular group 103
- divisor group 47
- polynomial 200

Product

- of differentials 46
- of double cosets 71

Properly discontinuously 17

Quadratic residue symbol 82

Quaternion algebra 199

Quotient space 5

Ramanujan–Pettersson conjecture 150

Ramification index

- of a covering 31
- of a point on $\Gamma \backslash \mathbf{H}^*$ 30

Ramify (a quaternion algebra is ramified) 199

Regular

- cuspidal 19
- element of a quaternion algebra 203
- representation of an algebra 195

Riemann

- sphere 1, 28
- surface 28
- zeta-function 84

Right half plane 276

Schwarz function 88

Side of a fundamental domain 23

Simple algebra 198

Space of primitive forms 164

Spherical function 186

Split (a quaternion algebra splits) 199

Splitting field of a quaternion algebra 199

Stabilizer 5

Stirling's estimate 87

Sum of differentials 46

Theta function 89, 187

Topological group 5

Totally

- imaginary algebraic number field 91
- real algebraic number field 91

Trace (of a quaternion algebra) 200

Transitive (action is) 5

Trivial character mod N 79

Unimodular 15

Unit

- disk 2
- group of norm 1 of a quaternion algebra 209

Upper half plane 2

Vertex 23

Weight of an automorphic form 37

Zero

- of a function on \mathfrak{R} 30
- at a cusp 39