

BLANK PAGE



**NATIONAL BUILDING CODE
OF INDIA 2005**

Group 1

NATIONAL BUILDING CODE OF INDIA 2005

GROUP 1

- PART 0 INTEGRATED APPROACH — PREREQUISITE FOR APPLYING PROVISIONS OF THE CODE
- PART 2 ADMINISTRATION
- PART 3 DEVELOPMENT CONTROL RULES AND GENERAL BUILDING REQUIREMENTS
- PART 4 FIRE AND LIFE SAFETY
- PART 5 BUILDING MATERIALS
- PART 10 LANDSCAPING, SIGNS AND OUTDOOR DISPLAY STRUCTURES
 - Section 1 Landscape Planning and Design
 - Section 2 Signs and Outdoor Display Structures

BUREAU OF INDIAN STANDARDS

SP 7 (Group 1) : 2005

FIRST PUBLISHED 1970
FIRST REVISION 1983
SECOND REVISION 2005

© BUREAU OF INDIAN STANDARDS

ICS 0.120; 91.040.01
ISBN 81-7061-026-5

PRICE Rs. 3030.00

PUBLISHED BY BUREAU OF INDIAN STANDARDS, MANAK BHAVAN, 9 BAHADUR SHAH ZAFAR MARG, NEW DELHI 110 002, PRINTED AT SUNSHINE PROCESS, C-105/5, NARAINA INDUSTRIAL AREA, PHASE I, NEW DELHI 110 028 (INDIA).

BIS Website: www.bis.org.in

FOREWORD

Construction programmes are interwoven in a large measure in all sectors of development, be it housing, transport, industry, irrigation, power, agriculture, education or health. Construction, both public and private, accounts for about fifty percent of the total outlay in any Five Year Plan. Half of the total money spent on construction activities is spent on buildings for residential, industrial, commercial, administrative, education, medical, municipal and entertainment uses. It is estimated that about half of the total outlay on buildings would be on housing. It is imperative that for such a large national investment, optimum returns are assured and wastage in construction is avoided.

Soon after the Third Plan, the Planning Commission decided that the whole gamut of operations involved in construction, such as, administrative, organizational, financial and technical aspects, be studied in depth. For this study, a Panel of Experts was appointed in 1965 by the Planning Commission and its recommendations are found in the 'Report on Economies in Construction Costs' published in 1968.

One of the facets of building construction, namely, controlling and regulating buildings through municipal byelaws and departmental handbooks received the attention of the Panel and a study of these regulatory practices revealed that some of the prevailing methods of construction were outmoded; some designs were overburdened with safety factors and there were other design criteria which, in the light of newer techniques and methodologies, could be rationalized; and building byelaws and regulations of municipal bodies which largely regulate the building activity in the country wherever they exist, were outdated. They did not cater to the use of new building materials and the latest developments in building designs and construction techniques. It also became clear that these codes and byelaws lacked uniformity and they were more often than not 'specification oriented' and not 'performance oriented'.

These studies resulted in a recommendation that a National Building Code be prepared to unify the building regulations throughout the country for use by government departments, municipal bodies and other construction agencies. The then Indian Standards Institution (now Bureau of Indian Standards) was entrusted by the Planning Commission with the preparation of the National Building Code. For fulfilling this task a Guiding Committee for the preparation of the Code was set up by the Civil Engineering Division Council of the Indian Standards Institution in 1967. This Committee, in turn, set up 18 specialist panels to prepare the various parts of the Code. The Guiding Committee and its panels were constituted with architects, planners, materials experts, structural, construction, electrical illumination, air conditioning, acoustics and public health engineers and town planners. These experts were drawn from the Central and State Governments, local bodies, professional institutions and private agencies. The first version of the Code was published in 1970.

After the National Building Code of India was published in 1970, a vigorous implementation drive was launched by the Indian Standards Institution to propagate the contents and use of the Code among all concerned in the field of planning, designing and construction activities. For this, State-wise Implementation Conferences were organized with the participation of the leading engineers, architects, town planners, administrators, building material manufacturers, building and plumbing services installation agencies, contractors, etc.

These Conferences were useful in getting across the contents of the Code to the interests concerned. These Conferences had also helped in the establishment of Action Committees to look into the actual implementation work carried out by the construction departments, local bodies and other agencies in different States. The main actions taken by the Action Committees were to revise and modernize their existing regulatory media, such as, specifications, handbooks, manuals, etc, as well as building byelaws of local bodies like municipalities at city and town levels, zilla parishads, panchayats and development authorities, so as to bring them in line with the provisions contained in the National Building Code of India. In this process, the Indian Standards Institution rendered considerable support in redrafting process.

Since the publication in 1970 version of the National Building Code of India, a large number of comments and useful suggestions for modifications and additions to different parts and sections of the Code were received as a result of use of the Code by all concerned, and revision work of building byelaws of some States. Based on the comments and suggestion received the National Building Code of India 1970 was revised in 1983.

Some of the important changes in 1983 version included : addition of development control rules, requirements for greenbelts and landscaping including norms for plantation of shrubs and trees, special requirements for low income housing; fire safety regulations for high rise buildings; revision of structural design section based on new and revised codes, such as Concrete Codes (plain and reinforced concrete and prestressed concrete), Earthquake Code, Masonry Code; addition of outside design conditions for important cities in the country, requirements relating to noise and vibration, air filter, automatic control, energy conservation for air conditioning; and guidance on the design of water supply system for multi-storeyed buildings.

The National Building Code of India is a single document in which, like a network, the information contained in various Indian Standards is woven into a pattern of continuity and cogency with the interdependent requirements of Sections carefully analyzed and fitted in to make the whole document a cogent continuous volume. A continuous thread of 'preplanning' is woven which, in itself, contributes considerably to the economies in construction particularly in building and plumbing services.

The Code contains regulations which can be immediately adopted or enacted for use by various departments, municipal administrations and public bodies. It lays down a set of minimum provisions designed to protect the safety of the public with regard to structural sufficiency, fire hazards and health aspects of buildings; so long as these basic requirements are met, the choice of materials and methods of design and construction is left to the ingenuity of the building professionals. The Code also covers aspects of administrative regulations, development control rules and general building requirements; fire protection requirements; stipulations regarding materials and structural design; rules for design of electrical installations, lighting, air conditioning and lifts; regulation for ventilation, acoustics and plumbing services, such as, water supply, drainage, sanitation and gas supply; measures to ensure safety of workers and public during construction; and rules for erection of signs and outdoor display structures.

Some other important points covered by the Code include 'industrialized systems of building' and 'architectural control'. The increase in population in the years to come will have a serious impact on the housing problem. It has been estimated that the urban population of India will continue to increase with such pace as to maintain the pressure on demand of accommodation for them. Speed of construction is thus of an utmost importance and special consideration has to be given to industrialized systems of building. With increased building activity, it is also essential that there should be some architectural control in the development of our cities and towns if creation of ugliness and slum-like conditions in our urban areas is to be avoided.

Since the publication of 1983 version of National Building Code of India, the construction industry has gone through major technological advancement. In the last two decades, substantial expertise has been gained in the areas of building planning, designing and construction. Also, lot of developments have taken places in the technological regime and techno-financial regime, apart from the enormous experience gained in dealing with natural calamities like super cyclones and earthquakes faced by the country. Further, since the last revision in 1983 based on the changes effected in the Steel Code, Masonry Code and Loading Code as also in order to update the fire protection requirements, three amendments were brought out to the 1983 version of the Code. Considering these, it was decided to take up a comprehensive revision of the National Building Code of India.

The changes incorporated in the present Code, which is second revision of the Code, have been specified in the Foreword to each Part/Section of the Code. Some of the important changes are:

- a) A new Part 0 'Integrated Approach — Prerequisite for Applying the Provisions of the Code' emphasizing on multi-disciplinary team approach for successfully accomplishing building/development project, has been incorporated.
- b) New chapters on significant areas like structural design using bamboo, mixed/composite construction and landscaping have been added.
- c) Number of provisions relating to reform in administration of the Code as also assigning duties and responsibilities to all concerned professionals, have been incorporated/modified. Also detailed provisions/performance to ensure structural sufficiency of buildings, have been prescribed so as to facilitate implementation of the related requirements to help safely face the challenges during natural disasters like earthquake.
- d) Planning norms and requirements for hilly areas and rural habitat planning, apart from detailed planning norms for large number of amenities have been incorporated.
- e) Fire safety aspects have been distinctly categorized into fire prevention, life safety and fire protection

giving detailed treatment to each based on current international developments and latest practices followed in the country.

- f) Aspects like energy conservation and sustainable development have been consistently dealt with in various parts and sections through appropriate design, usage and practices with regard to building materials, construction technologies and building and plumbing services. Renewable resources like bamboo and practices like rain water harvesting have been given their due place.
- g) The latest revised earthquake code, IS 1893 (Part 1) : 2002 'Criteria for earthquake resistant design of structures: Part 1 General provisions and buildings', has been incorporated, due implementation of the provisions of which in applicable seismic zone of the country, needs to be duly adhered to by the Authorities.

The Code now published is the third version representing the present state of knowledge on various aspects of building construction. The process of preparation of the 2005 version of the Code had thrown up a number of problems; some of them were answered fully and some partially. Therefore, a continuous programme will go on by which additional knowledge that is gained through technological evolution, users' views over a period of time pinpointing areas of clarification and coverage and results of research in the field, would be incorporated in to the Code from time to time to make it a living document. It is, therefore, proposed to bring out changes to the Code periodically.

The provisions of this Code are intended to serve as a model for adoption by Public Works Departments and other government construction departments, local bodies and other construction agencies. Existing PWD codes, municipal byelaws and other regulatory media could either be replaced by the National Building Code of India or suitably modified to cater to local requirements in accordance with the provisions of the Code. Any difficulties encountered in adoption of the Code could be brought to the notice of the Sectional Committee for corrective action.

This publication forms part of the National Building Code of India 2005 and contains the following Parts:

PART 0 INTEGRATED APPROACH - PREREQUISITE FOR APPLYING PROVISIONS OF THE CODE

PART 2 ADMINISTRATION

PART 3 DEVELOPMENT CONTROL RULES AND GENERAL BUILDING REQUIREMENTS

PART 4 FIRE AND LIFE SAFETY

PART 5 BUILDING MATERIALS

PART 10 LANDSCAPING, SIGNS AND OUTDOOR DISPLAY STRUCTURES

Section 1 Landscape Planning and Design

Section 2 Signs and Outdoor Display Structures

The information contained in this publication will essentially serve the concerned professionals in dealing with the development and building schemes from the early stages of planning.

Chairman

Dr H. C. VISVESVARAYA

‘Chandrika’, at 15th Cross, 63-64 East Park Road
Malleswaram, Bangalore 560 003

Vice-Chairman

SHRI V. SURESH

P-233/3, Officers Enclave,
Air Force Station, Rajokari, New Delhi 110 038

<i>Organization</i>	<i>Representative(s)</i>
Ahmedabad Municipal Corporation, Ahmedabad	SHRI VATSAL S. PATEL SHRI JAGDISH A. PATEL (<i>Alternate</i>)
Bangalore Mahanagara Palike, Bangalore	SHRI M. R. SREENIVASA MURTHY SHRI R. RAMEGOWDA (<i>Alternate I</i>) SHRI N. KRISHNA (<i>Alternate II</i>)
Builders Association of India, Mumbai	SHRI B. G. AHUJA
Building Materials and Technology Promotion Council, New Delhi	SHRI T. N. GUPTA & SHRI D. B. N. RAO
Bureau of Energy Efficiency (Ministry of Power), New Delhi	REPRESENTATIVE
Central Building Research Institute (CSIR), Roorkee	SHRI V. K. MATHUR SHRI B. S. GUPTA (<i>Alternate</i>)
Central Public Health and Environmental Engineering Organisation (Ministry of Urban Development and Poverty Alleviation), New Delhi	SHRI B. B. UPPAL SHRI V. K. CHAURASIA (<i>Alternate</i>)
Central Public Works Department (Central Designs Organization), New Delhi	CHIEF ENGINEER (DESIGNS) SUPERINTENDING ENGINEER (S & S) (<i>Alternate</i>)
Central Public Works Department (Electrical Department), New Delhi	CHIEF ENGINEER (ELECTRICAL) I
Centre for Disaster Mitigation and Management, Anna University, Chennai	DIRECTOR
Chennai Metropolitan Development Authority, Chennai	MEMBER SECRETARY SHRI N. V. RAKHUNATH (<i>Alternate</i>)
Construction Industry Development Council, New Delhi	SHRI P. R. SWARUP SHRI ANIL CHADHA (<i>Alternate</i>)
Council of Architecture, New Delhi	SHRI PREMENDRA RAJ MEHTA SHRI SUDHIR VOHRA (<i>Alternate</i>)
Delhi Development Authority, New Delhi	ENGINEER MEMBER CHIEF ENGINEER (HQ) (<i>Alternate</i>)
Delhi Fire Service, Government of National Capital Territory of Delhi, Delhi	SHRI R. C. SHARMA
Department of Science and Technology (Ministry of Science and Technology), New Delhi	SHRI V. RAO ALYAGARI
Directorate General of Employment and Training, New Delhi	SHRI ASHWANI KUMAR
Engineer-in-Chief’s Branch, Army Headquarters, New Delhi	BRIG S. K. SHARMA SHRI D. K. DINKER (<i>Alternate</i>)
Forest Research Institute (Indian Council for Forestry Research and Education), Dehra Dun	DIRECTOR GENERAL DIRECTOR (<i>Alternate</i>)
Housing and Urban Development Corporation Ltd, New Delhi	CHAIRMAN & MANAGING DIRECTOR SHRI R. K. SAFAYA (<i>Alternate</i>)
Indian Geotechnical Society, New Delhi	SHRI D. B. MAHAJAN DR M. D. DESAI (<i>Alternate</i>)

<i>Organization</i>	<i>Representative(s)</i>
Indian Institute of Technology (Centre for Energy Studies), New Delhi	PROF N. K. BANSAL
Indian Roads Congress, New Delhi	CHIEF ENGINEER (DESIGN), CPWD SUPERINTENDING ENGINEER (DESIGN), CPWD (<i>Alternate</i>)
Institute of Town Planners, India, New Delhi	DR S. K. KULSHRESTHA
Institution of Fire Engineers (India), New Delhi	PRESIDENT GENERAL SECRETARY (<i>Alternate</i>)
Ministry of Home Affairs, New Delhi	FIRE ADVISOR
Ministry of Home Affairs (Disaster Management Division), New Delhi	SHRI M. P. SAINANI SHRI S. K. SWAMI (<i>Alternate</i>)
Ministry of Non-Conventional Energy Sources, New Delhi	DR T. C. TRIPATHI
Ministry of Road Transport and Highways, New Delhi	SHRI S. B. BASU SHRI P. HALDER (<i>Alternate</i>)
Municipal Corporation of Greater Mumbai, Mumbai	DIRECTOR (ENGG SERVICES & PROJECTS) CITY ENGINEER (<i>Alternate</i>)
National Buildings Construction Corporation, New Delhi	SHRI B. PRASAD SHRI N. P. AGARWAL (<i>Alternate</i>)
National Council for Cement and Building Materials, Ballabgarh	SHRI SHIBAN RAINA DR ANIL KUMAR (<i>Alternate</i>)
National Design and Research Forum, The Institution of Engineers (India), Bangalore	PROF R. NARAYANA IYENGAR SHRI B. SURESH (<i>Alternate</i>)
National Environmental Engineering Research Institute (CSIR), Nagpur	DR ARINDAM GHOSH DR V. P. DESHPANDE (<i>Alternate</i>)
North Eastern Council, Shillong	SHRI P. K. DEB
Public Works Department (Roads and Buildings), Gandhinagar	SHRI V. P. JAMDAR SHRI M. S. JALLUNDHWALA (<i>Alternate</i>)
Research, Designs and Standards Organization (Ministry of Railways), Lucknow	SHRI R. K. GUPTA SHRI J. P. DAS (<i>Alternate</i>)
School of Planning and Architecture, New Delhi	DIRECTOR
Structural Engineering Research Centre (CSIR), Chennai	SHRI C. V. VAIDYANATHAN SHRI K. MANI (<i>Alternate</i>)
Suri and Suri Consulting Acoustical Engineers, New Delhi	SHRI GAUTAM SURI
The Energy and Resources Institute, New Delhi	MS MILI MAJUMDAR MS VIDISHA SALUNKE-PALSULE (<i>Alternate</i>)
The Indian Institute of Architects, New Delhi	SHRI BALBIR VERMA SHRI ABHIJIT RAY (<i>Alternate</i>)
The Institution of Engineers (India), Kolkata	PROF G. P. LAL SHRI O. P. GOEL (<i>Alternate</i>)
The Institution of Surveyors, New Delhi	SHRI K. S. KHARB SHRI R. K. BHALLA (<i>Alternate</i>)
Town and Country Planning Organization, New Delhi	SHRI K. T. GURUMUKHI SHRI J. B. KSHIRSAGAR (<i>Alternate</i>)
U.P. Housing and Development Board, Lucknow	SHRI HARI GOPAL
Unitech Ltd, Gurgaon	SHRI SUSHIL SHARMA SHRI SHAHID MAHMOOD (<i>Alternate</i>)
In personal capacity (5, Sunder Nagar, New Delhi 110 003)	DR J. R. BHALLA
BIS Directorate General	SHRI S. K. JAIN, Director & Head (Civil Engineering) [Representing Director General (<i>Ex-officio Member</i>)]

Member Secretary
SHRI SANJAY PANT
Joint Director (Civil Engineering), BIS

**Special Panel for Guiding and Co-ordinating the
Revision of National Building Code of India, CED 46:SP**

<i>Organization</i>	<i>Representative(s)</i>
In personal capacity (P-233/3, Officers Enclave, Air Force Station, Rajokari, New Delhi 110 038)	SHRI V. SURESH (Convener)
Building Materials and Technology Promotion Council, New Delhi	SHRI T. N. GUPTA
Central Building Research Institute (CSIR), Roorkee	SHRI V. K. MATHUR
Central Public Works Department, New Delhi	SHRI H. S. DOGRA
Council of Architecture, New Delhi	SHRI PREMENDRA RAJ MEHTA
Engineer-in-Chief's Branch, Army Headquarters, New Delhi	LT-GEN HARI UNIYAL
The Institution of Engineers (India), Kolkata	PROF G. P. LAL SHRI O. P. GOEL (<i>Alternate</i>)
Bureau of Indian Standards, New Delhi	SHRI SANJAY PANT

Ad-hoc Group for Part 0 of NBC, CED 46:AG

<i>Organization</i>	<i>Representative(s)</i>
In personal capacity ('Chandrika', at 15th Cross, 63-64, East Park Road, Malleswaram, Bangalore 560 003)	DR H. C. VISVESVARAYA (Convener)
Council of Architecture, New Delhi	SHRI PREMENDRA RAJ MEHTA
In personal capacity (P-233/3, Officers Enclave, Air Force Station, Rajokari, New Delhi 110 038)	SHRI V. SURESH
In personal capacity (A-39/B, DDA Flats, Munirka, New Delhi 110 067)	SHRI P. B. VIJAY
In personal capacity (EA-345, Maya Enclave, New Delhi 110 064)	SHRI J. N. BHAVANI PRASAD

**Panel for Administration, Development Control Rules and
General Building Requirements, CED 46:P1**

<i>Organization</i>	<i>Representative(s)</i>
In personal capacity (P-233/3, Officers Enclave, Air Force Station, Rajokari, New Delhi 110 038)	SHRI V. SURESH (Convener)
Ahmedabad Municipal Corporation, Ahmedabad	REPRESENTATIVE
Building Materials and Technology Promotion Council, New Delhi	SHRI T. N. GUPTA SHRI RAJESH MALIK (<i>Alternate</i>)
Central Building Research Institute (CSIR), Roorkee	SHRI V. K. MATHUR SHRI N. K. SHANGARI (<i>Alternate</i>)
Central Public Works Department, New Delhi	SHRI R. S. KAUSHAL SHRI SANJIB SENGUPTA (<i>Alternate</i>)
Consulting Engineers Association of India, New Delhi	SHRI S. C. MEHROTRA SHRI N. F. PATEL (<i>Alternate</i>)
Council of Architecture, New Delhi	SHRI PREMENDRA RAJ MEHTA SHRI SUDHIR VOHRA (<i>Alternate</i>)
Delhi Development Authority, New Delhi	SHRI R. C. KINGER SHRI A. K. GUPTA (<i>Alternate</i>)
Housing and Urban Development Corporation Ltd, New Delhi	SHRI K. C. BATRA
Indian Association of Structural Engineers, New Delhi	SHRI MAHENDRA RAJ
Institute of Town Planners (India), New Delhi	DR S. K. KULSHRESTHA
Municipal Corporation of Delhi, Delhi	ENGINEER-IN-CHIEF SHRI M. M. DAS (<i>Alternate</i>)
Municipal Corporation of Greater Mumbai, Mumbai	CHIEF ENGINEER (DEVELOPMENT PLAN) DEPUTY CHIEF ENGINEER (DEVELOPMENT PLAN)-I (<i>Alternate</i>)
National Council for Cement and Building Materials, Ballabgarh	DR ANIL KUMAR

Organization

National Real Estate Development Council, New Delhi
 School of Planning and Architecture, New Delhi
 The Indian Institute of Architects, Mumbai
 The Institution of Engineers (India), Kolkata
 Town and Country Planning Organization, New Delhi

Representative(s)

BRIG R. R. SINGH (RETD)
 PROF SUBIR SAHA
 SHRI BALBIR VERMA
 SHRI ABHIJIT RAY (*Alternate*)
 SHRI A. D. SHIRODE
 SHRI P. B. VIJAY (*Alternate*)
 SHRI J. B. KSHIRSAGAR
 SHRI R. SRINIVAS (*Alternate*)

Panel for Fire Protection, CED 46:P2

Organization

In personal capacity (29/25, Old Rajendra Nagar, New Delhi 110 060)
 Central Building Research Institute (CSIR), Roorkee
 Central Public Works Department, New Delhi
 Deolalikar Consultants Pvt Ltd, New Delhi
 Directorate of Town and Country Planning, Government of Tamil Nadu,
 Chennai
 Engineer-in-Chief's Branch, Army Headquarters, New Delhi
 Institution of Fire Engineers (India), New Delhi
 Lloyd Insulations (India) Ltd, New Delhi
 Ministry of Home Affairs, New Delhi
 Delhi Fire Service, Government of National Capital Territory of Delhi,
 Delhi
 Municipal Corporation of Greater Mumbai (Mumbai Fire Brigade),
 Mumbai
 National Council for Cement and Building Materials, Ballabgarh
 National Fire Service College (Ministry of Home Affairs), Nagpur
 Oil Industry Safety Directorate, New Delhi
 Regional Research Laboratory (CSIR), Jorhat
 Spectral Services Consultants Pvt Ltd, New Delhi
 Tariff Advisory Committee, Mumbai
 The Institution of Engineers (India), Kolkata
 In personal capacity (P-233/3, Officers Enclave, Air Force Station,
 Rajokari, New Delhi 110 038)

Representative(s)

SHRI S. K. DHERI (**Convener**)
 DR T. P. SHARMA
 DR GOPAL KRISHNA (*Alternate*)
 SHRI ARVIND KANSAL
 SHRI R. S. KAUSHAL (*Alternate*)
 SHRI S. G. DEOLALIKAR
 SHRI S. DHANASEKARAN
 SHRI R. RAJAGOPALAN (*Alternate*)
 SHRI R. A. DUBEY
 SHRI AJAY SHANKAR (*Alternate*)
 SHRI U. S. CHHILLAR
 SHRI S. P. BATRA (*Alternate*)
 SHRI SANJEEV ANGRA
 SHRI K. K. MITRA (*Alternate*)
 SHRI OM PRAKASH
 SHRI D. K. SHAMMI (*Alternate*)
 SHRI R. C. SHARMA
 SHRI G. C. MISRA (*Alternate*)
 SHRI A. D. JHANDWAL
 SHRI V. H. NAIK (*Alternate*)
 DR ANIL KUMAR
 DR K. C. WADHWA
 SHRI SHAMIM (*Alternate*)
 SHRI D. JAGANNATH
 SHRI S. K. AGGARWAL (*Alternate*)
 REPRESENTATIVE
 SHRI SANDEEP GOEL
 SHRI Z. U. ISLAM
 SHRI D. N. SAHA (*Alternate*)
 PROF M. P. CHOWDIAH
 SHRI K. B. RAJORIA (*Alternate*)
 SHRI V. SURESH

Panel for Building Materials, CED 46:P3

Organization

Building Materials and Technology Promotion Councils, New Delhi
 Central Building Research Institute (CSIR), Roorkee
 Central Public Works Department, New Delhi

Representative(s)

SHRI T. N. GUPTA (**Convener**)
 DR C. L. VERMA
 SHRI L. K. AGARWAL (*Alternate*)
 SHRI H. K. L. MEHTA
 SHRI R. C. GUPTA (*Alternate*)

<i>Organization</i>	<i>Representative(s)</i>
Council of Architecture, New Delhi	SHRI ANURAG ROY SHRI ATUL GUPTA (<i>Alternate</i>)
Department of Science and Technology (Ministry of Science and Technology), New Delhi	SHRI SOUMITRA BISWAS SHRI G. SRIKANTH (<i>Alternate</i>)
Engineer-in-Chief's Branch, Army Headquarters, New Delhi	SHRI A. K. SINGH SHRI P. K. GUPTA (<i>Alternate</i>)
Housing and Urban Development Corporation Ltd, New Delhi	CHAIRMAN AND MANAGING DIRECTOR SHRI S. K. TANEJA (<i>Alternate</i>)
Indian Plywood Industries Research and Training Institute, Bangalore	SHRI K. SHYAMASUNDAR SHRI M. PAWAN KUMAR (<i>Alternate</i>)
National Council for Cement and Building Materials, Ballabgarh	SHRI SHIBAN RAINA DR K. MOHAN (<i>Alternate</i>)
The Institution of Engineers (India), Kolkata	SHRI G. L. RAO SHRI R. S. GOEL (<i>Alternate</i>)

Panel for Landscaping, Signs and Outdoor Display Structures, CED 46:P18

<i>Organization</i>	<i>Representative(s)</i>
In personal capacity (5, Sunder Nagar, New Delhi 110003) Central Public Works Department, New Delhi	DR J. R. BHALLA (<i>Convener</i>) SHRI ARVIND KANSAL SHRI A. N. DEVIKAR (<i>Alternate</i>)
Council of Architecture, New Delhi Delhi Urban Arts Commission, New Delhi	KUMARI VINITA C. K. VIJAYAN SHRI H. K. YADAV SHRI DINA NATH (<i>Alternate</i>)
Housing and Urban Development Corporation, New Delhi Institute of Town Planners, India, New Delhi Municipal Corporation of Delhi, Delhi	SHRI R. K. SAFAYA DR S. K. KULSHRESTHA SHRI S. S. HADKE SHRI S. RAMESH (<i>Alternate</i>)
Municipal Corporation of Greater Mumbai, Mumbai	SHRI M. S. GHAG SHRI R. K. RAHATE (<i>Alternate</i>)
National Institute of Design, Ahmedabad	SHRI ANANDO DUTTA SHRI J. G. SEVAK (<i>Alternate</i>)
Selvel Publicity and Consultants Pvt Ltd, Mumbai Shaheer Associates, New Delhi	SHRI K. S. NICHOLSON PROF M. SHAHEER
Town and Country Planning Organization, New Delhi	SHRI J. B. KSHIRSAGAR SHRI Y. RAMESH (<i>Alternate</i>)
The Indian Institute of Architects, Mumbai The Institution of Engineers (India), Kolkata	SHRI MAHESH PALIWAL PROF JITENDRA SINGH
In personal capacity (D-198, Defence Colony, New Delhi 110024)	SHRI RAVINDRA BHAN

Member Secretary

SHRI SANJAY PANT

Joint Director (Civil Engineering), BIS

Joint Member Secretary

SHRI S. K. VERMA

Deputy Director (Civil Engineering), BIS

Important Explanatory Note for Users of Code

In this Code, where reference is made to ‘accepted standards’ in relation to material specification, testing or other related information or where reference is made to ‘good practice’ in relation to design, constructional procedures or other related information, the Indian Standards listed at the end of the concerned Parts/Sections may be used to the interpretation of these terms.

At the time of publication, the editions indicated in the above Indian Standards were valid. All standards are subject to revision and parties to agreements based on the Parts/Sections are encouraged to investigate the possibility of applying the most recent editions of the standards.

In the list of standards given at the end of each Part/Section, the number appearing in the first column indicates the number of the reference in that Part/Section. For example:

- a) accepted standard [3(1)] refers to the standard given at serial number 1 of the list of standards given at the end of Part 3, that is IS 8888 (Part 1) : 1993 ‘Guide for requirements of low income housing: Part 1 Urban area (*first revision*)’.
- b) good practice [4(3)] refers to the standard given at serial number 3 of the list of standards given at the end of Part 4, that is IS 15394 : 2003 ‘Code of practice for fire safety in petroleum refinery and fertilizer plants’.
- c) accepted standard [4(11)] refers to the standard given at serial number 11 of the list of standards given at the end of Part 4, that is IS 11360 : 1985 ‘Specification for smoke detectors for use in automatic electrical fire alarm system’.
- d) good practice [4(28)] refers to the standard given at serial number 28 of the list of standards given at the end of Part 4, that is IS 12456 : 1988 ‘Code of practice for fire protection of electronic data processing installations’.
- e) good practice [10-2(3)] refers to the standard given at serial number 3 of the list of standards given at the end of Section 2 of Part 10, that is IS 401 : 2001 ‘Code of practice for preservation of timber (*fourth revision*)’.

INFORMATION FOR THE USERS

For the convenience of the users, the National Building Code of India 2005 is available as a comprehensive volume as well as in the following five groups, each incorporating the related Parts/Sections dealing with particular area of building activity:

Group 1	For Development, Building Planning and Related Aspects	Part 0:	Integrated Approach — Prerequisite for Applying Provisions of the Code				
		Part 2:	Administration				
		Part 3:	Development Control Rules and General Building Requirements				
		Part 4:	Fire and Life Safety				
		Part 5:	Building Materials				
		Part 10:	Landscaping, Signs and Outdoor Display Structures Section 1 Landscape Planning and Design Section 2 Signs and Outdoor Display Structures				
Group 2	For Structural Design and Related Aspects	Part 0:	Integrated Approach — Prerequisite for Applying Provisions of the Code				
		Part 6:	Structural Design Section 1 Loads, Forces and Effects Section 2 Soils and Foundations Section 3 Timber and Bamboo 3A Timber 3B Bamboo Section 4 Masonry Section 5 Concrete 5A Plain and Reinforced Concrete 5B Prestressed Concrete Section 6 Steel Section 7 Prefabrication, Systems Building and Mixed/Composite Construction 7A Prefabricated Concrete 7B Systems Building and Mixed/Composite Construction				
		Group 3	For Construction Related Aspects including Safety	Part 0:	Integrated Approach — Prerequisite for Applying Provisions of the Code		
				Part 7:	Constructional Practices and Safety		
		Group 4	For Aspects Relating to Building Services	Part 0:	Integrated Approach — Prerequisite for Applying Provisions of the Code		
				Part 8:	Building Services Section 1 Lighting and Ventilation Section 2 Electrical and Allied Installations Section 3 Air conditioning, Heating and Mechanical Ventilation Section 4 Acoustics, Sound Insulation and Noise Control Section 5 Installation of Lifts and Escalators		
				Group 5	For Aspects Relating to Plumbing Services including Solid Waste Management	Part 0:	Integrated Approach — Prerequisite for Applying Provisions of the Code
						Part 9:	Plumbing Services Section 1 Water Supply, Drainage and Sanitation (including Solid Waste Management) Section 2 Gas Supply

The information contained in different groups will essentially serve the concerned professionals dealing in the respective areas.

The National Building Code of India consists of the following Parts and Sections:

		<i>Total Pages</i>
PART 0	INTEGRATED APPROACH — PREREQUISITE FOR APPLYING PROVISIONS OF THE CODE	... 12
PART 1	DEFINITIONS	... 16
PART 2	ADMINISTRATION	... 24
PART 3	DEVELOPMENT CONTROL RULES AND GENERAL BUILDING REQUIREMENTS	... 64
PART 4	FIRE AND LIFE SAFETY	... 88
PART 5	BUILDING MATERIALS	... 40
PART 6	STRUCTURAL DESIGN	
	Section 1 Loads, Forces and Effects	... 104
	Section 2 Soils and Foundations	... 48
	Section 3 Timber and Bamboo	
	3A Timber	... 50
	3B Bamboo	... 24
	Section 4 Masonry	... 44
	Section 5 Concrete	
	5A Plain and Reinforced Concrete	... 90
	5B Prestressed Concrete	... 6
	Section 6 Steel	... 8
	Section 7 Prefabrication, Systems Building and Mixed/Composite Construction	
	7A Prefabricated Concrete	... 22
	7B Systems Building and Mixed/Composite Construction	... 12
PART 7	CONSTRUCTIONAL PRACTICES AND SAFETY	... 70
PART 8	BUILDING SERVICES	
	Section 1 Lighting and Ventilation	... 48
	Section 2 Electrical and Allied Installations	... 68
	Section 3 Air Conditioning, Heating and Mechanical Ventilation	... 48
	Section 4 Acoustics, Sound Insulation and Noise Control	... 44
	Section 5 Installation of Lifts and Escalators	... 42
PART 9	PLUMBING SERVICES	
	Section 1 Water Supply, Drainage and Sanitation (including Solid Waste Management)	... 90
	Section 2 Gas Supply	... 14
PART 10	LANDSCAPING, SIGNS AND OUTDOOR DISPLAY STRUCTURES	
	Section 1 Landscape Planning and Design	... 30
	Section 2 Signs and Outdoor Display Structures	... 24

NATIONAL BUILDING CODE OF INDIA

PART 0 INTEGRATED APPROACH — PREREQUISITE FOR APPLYING PROVISIONS OF THE CODE

BUREAU OF INDIAN STANDARDS

CONTENTS

FOREWORD	...	3
1 SCOPE	...	5
2 TERMINOLOGY	...	5
3 GENERAL	...	5
4 TEAM APPROACH	...	5
5 PLANNING, DESIGNING AND DEVELOPMENT	...	6
6 CONSTRUCTION/EXECUTION (ACTUALIZATION)	...	7
7 OPERATION AND MAINTENANCE	...	8
ANNEX A BRIEF DETAILS OF THE COVERAGE OF VARIOUS PROVISIONS UNDER DIFFERENT OTHER PARTS/SECTIONS OF THIS CODE	...	9

FOREWORD

In order to provide safe and healthy habitat, careful consideration needs to be paid to the building construction activity. Building planning, designing and construction activities have developed over the centuries. Large number of ancient monuments and historical buildings all over the world bear testimony to the growth of civilization from the prehistoric era with the extensive use of manual labour and simple systems as appropriate to those ages to the present day mechanized and electronically controlled operations for designing and constructing buildings and for operating and maintaining systems and services. In those days those buildings were conceptualized and built by master builders with high levels of artisan skills. Technological and socio-economic developments in recent times have led to remarkable increase in demand for more and more sophistication in buildings resulting in ever increasing complexities. These perform demand high levels of inputs from professionals of different disciplines such as architecture, civil engineering, structural engineering, functional and life safety services including special aspects relating to utilities, landscaping, etc in conceptualization, spatial planning, design and construction of buildings of various material and technology streams, with due regard to various services including operation, maintenance, repairs and rehabilitation aspects throughout the service life of the building.

This Code, besides prescribing the various provisions, also allows freedom of action to adopt appropriate practices and provides for building planning, designing and construction for absorbing traditional practices as well as latest developments in knowledge in the various disciplines as relevant to a building including computer aided and/or other modern sensors aided activities in the various stages of conceptualization, planning, designing, constructing, maintaining and repairing the buildings. India being a large country with substantial variations from region to region, this Code has endeavoured to meet the requirements of different regions of the country, both urban and rural, by taking into consideration factors, such as, climatic and environmental conditions, geographical terrain, proneness to natural disasters, ecologically appropriate practices, use of eco-friendly materials, reduction of pollution, protection and improvement of local environment and also socio-economic considerations, towards the creation of sustainable human settlements.

This Part of the Code dealing with ‘integrated approach’ is being included for the first time. It gives an overall direction for practical applications of the provisions of different specialized aspects of spatial planning, designing and construction of buildings, creation of services, and proposes an integrated approach for utilizing appropriate knowledge and experience of qualified professionals right from the conceptualization through construction and completion stages of a building project and indeed during the entire life cycle. The ‘integrated approach’ should not only take care of functional, aesthetic and safety aspects, but also the operational and maintenance requirements. Also, cost optimization has to be achieved through proper selection of materials, techniques, equipment installations, etc. Further, value engineering and appropriate management techniques should be applied to achieve the aim set forth for the purpose of construction of a building fully meeting the specified and implied needs of spatial functions, safety and durability aspects, life and health safety, comfort, services, etc in the building.

The aim of the ‘integrated approach’ is to get the maximum benefit from the building and its services in terms of quality, timely completion and cost-effectiveness. In the team approach which is an essential pre-requisite for integrated approach, the aim clearly is to maximize the efficiency of the total system through appropriate optimization of each of its sub-systems. In other words, in the team, the inputs from each of the professional disciplines have to be so optimized that the total system’s efficiency becomes the maximum. It may be re-emphasized that maximizing the efficiencies of each sub-system may not necessarily assure the maximization of the efficiency of the total system. It need hardly to be stated that specified or implied safety will always get precedence over functional efficiency and economy. Further, progressive approach such as that relating to the concept of intelligent buildings would be best taken care of by the ‘integrated approach’ as laid down in this Part.

Quality systems approach and certification thereunder covering the various dimensions brought out above may go a long way in achieving the above goal of real integrated approach.

NATIONAL BUILDING CODE OF INDIA

PART 0 INTEGRATED APPROACH — PREREQUISITE FOR APPLYING PROVISIONS OF THE CODE

1 SCOPE

This Part covers guidelines to be followed for judicious implementation of the provisions of various Parts/Sections of the Code.

2 TERMINOLOGY

2.0 For the purpose of this Part, the following definitions and those given in Part 1 ‘Definitions’ shall apply.

2.1 Authority Having Jurisdiction — The Authority which has been created by a statute and which, for the purpose of administering the Code/Part, may authorize a committee or an official or an agency to act on its behalf; hereinafter called the ‘Authority’.

2.2 Building — Any structure for whatsoever purpose and of whatsoever materials constructed and every part thereof whether used as human habitation or not and includes foundation, plinth, walls, floors, roofs, chimneys, plumbing and building services, fixed platforms, *VERANDAH*, balcony, cornice or projection, part of a building or anything affixed thereto or any wall enclosing or intended to enclose any land or space and signs and outdoor display structures. Tents/*SHAMIANAHS/PANDALS*, tarpaulin shelters, etc, erected for temporary and ceremonial occasions shall not be considered as building.

2.3 Owner — Person or body having a legal interest in land and/or building thereon. This includes free holders, leaseholders or those holding a sub-lease which both bestows a legal right to occupation and gives rise to liabilities in respect of safety or building condition.

In case of lease or sub-lease holders, as far as ownership with respect to the structure is concerned, the structure of a flat or structure on a plot belongs to the allottee/lessee till the allotment/lease subsists.

NOTE — For the purpose of the Code, the word ‘owner’ will also cover the generally understood terms like ‘client’, ‘user’, etc.

3 GENERAL

3.1 Buildings, shall be classified as Residential, Educational, Institutional, Assembly, Business, Mercantile, Industrial, Storage and Hazardous in groups and sub-division as classified in Part 4 ‘Fire and Life Safety’.

For further sub-classification of buildings and various related provisions thereof with respect to administration;

development control rules and general building requirements; building materials; fire and life safety; structural design; constructional practices and safety; building and plumbing services; and landscaping, signs and outdoor display structures, other parts/sections of the Code may be referred to.

3.2 The scope of various Parts/Sections of the Code which cover detailed provisions on different aspects of development of land/building construction activity, are given in Annex A, with a view to providing an overview for the users of the Code.

4 TEAM APPROACH

A land development/building project comprises the following major stages:

- a) Location/siting,
- b) Conceptualization and planning,
- c) Designing and detailing,
- d) Construction/execution, and
- e) Maintenance and repair.

Each stage necessarily requires professionals of many disciplines who should work together as a well coordinated team to achieve the desired product delivery with quality, in an effective manner.

Appropriate multi-disciplinary teams need to be constituted to successfully meet the requirements of different stages. Each team may comprise need based professionals out of the following depending upon the nature, magnitude and complexity of the project:

- a) Architect,
- b) Civil engineer,
- c) Structural engineer,
- d) Electrical engineer,
- e) Plumbing engineer,
- f) Fire protection engineer,
- g) HVAC engineer,
- h) Environment specialist,
- j) Town planner,
- k) Urban designer,
- m) Landscape architect,
- n) Security system specialist,
- p) Interior designer,
- q) Quantity surveyor,
- r) Project/construction manager, and
- s) Other subject specialist(s).

4.1 Design Team

In building projects various aspects like form; space planning; aesthetics; fire and life safety; structural adequacy; plumbing services; lighting and natural ventilation; electrical and allied installations; air conditioning, heating and mechanical ventilation; acoustics, sound insulation and noise control; installation of lifts and escalators; building automation; data and voice communication; other utility services installations; landscape planning and design; urban planning; etc need to be kept in view right at the concept stage. The project requiring such multi-disciplinary inputs need a co-ordinated approach among the professionals for proper integration of various design inputs. For this, and to take care of the complexities of multi-disciplinary requirements, a design team of professionals from required disciplines shall be constituted at the appropriate stage. Here, it is desirable that the multi-disciplinary integration is initiated right from the concept stage. The team shall finalize the plan. The composition of the team shall depend on the nature and magnitude of the project. Design is an evolutionary and participatory process, where participation of owner constitutes a very important input at all stages, and the same shall be ensured by the design team.

To ensure proper implementation of the design, the design team, may be associated during the construction/execution stage.

4.2 Project Management and Construction Management Teams

The objective of project management or construction management is primarily to achieve accomplishment of project in accordance with the designs and specifications in a stipulated time and cost framework, with a degree of assurance prior to commencement and satisfaction on accomplishment.

For large projects, separate teams of experienced professionals from the required disciplines may be constituted for project management and for construction management depending upon the complexities of the project. However, for smaller projects these teams may be combined. The teams shall be responsible for day-to-day execution, supervision, quality control, etc and shall ensure inter-disciplinary co-ordination during the construction stage. The team shall be responsible to achieve satisfactory completion of the project with regard to cost, time and quality. Some members of the design team may also be included in the project management team and/or associated actively during the project execution stage. It is important that leaders and members of project management/construction management teams,

depending on the size and complexity of the project, are carefully selected considering their qualification, experience and expertise in these fields.

4.3 Operation and Maintenance Team

Operation, maintenance and repairs also require a multi-disciplinary approach to ensure that all the requirements of the users are satisfactorily met. During maintenance and repairs, the jobs requiring inter-disciplinary co-ordination have to be executed in such a manner as not only to cause least inconvenience to the user but also to ensure that there is no mismatch or damage to the structure, finishings, fittings and fixtures. For carrying out routine maintenance/repair jobs, utilization of the services of trained technicians preferably having multi-disciplinary skills should be encouraged.

Special repairs, rehabilitation and retrofitting are specialized jobs which demand knowledge of the existing structure/installations. Association of concerned specialists may be helpful for these works.

The Operation and Maintenance Team may also be known as Asset Management or Estate Management Team.

5 PLANNING, DESIGNING AND DEVELOPMENT

5.1 The main functions of design team (*see 4.1*) constituted for the planning, designing and development, are as under:

- a) Formalization of design brief in consultation with the owner.
- b) Site investigation/survey.
- c) Preparation of alternative concept designs.
- d) Selection of a concept in consultation with and with the consent of owner.
- e) Sizing the system.
- f) Development of design, covering :
 - 1) Integration of architecture, structure and services,
 - 2) Synthesis of requirements of each discipline, and
 - 3) Interaction with each other and with the owner.
- g) Preparation of preliminary designs and drawings and obtaining owner's approval.
- h) Preparation of preliminary cost estimates for approval of owner.
- j) Preparation of work-breakdown structure and programme for pre-construction activities.
- k) Assisting client to obtain approvals of the Authority.
- m) Preparation of detailed specification and

construction working drawings with integration of engineering inputs of all concerned disciplines.

- n) Preparation of detailed design of each discipline for various services.
- p) Peer review/proof checking of the drawings/designs in case of important projects, depending upon their complexity and sensitivity.
- q) Preparation of detailed cost estimate.
- r) Obtaining final approval of client.
- s) Preparation of bill of quantities, specifications and tender documents.

5.2 The following considerations, as may be applicable to the project, may be considered during planning, notwithstanding other relevant aspects specifically prescribed in concerned parts/sections of this Code; these considerations in general are with the objective of addressing to the important issues like environmental protection, energy conservation, cultural issues, creating barrier free built-environment, safety aspects, etc, all of these leading towards sustainable development, and have to be applied with due regard to the specific requirements of size and type of project:

- a) Geoclimatic, geological and topographical features.
- b) Varied sociological pattern of living in the country.
- c) Effective land use to cater to the needs of the society in a most convenient manner.
- d) Modular planning and standardization to take care of future planning giving due consideration to the specified planning controls.
- e) Emphasis on daylight utilization, natural ventilation, shielding, and window area and its disposition; daylighting to be supplemented with an integrated design of artificial lighting.
- f) Optimum utilization of renewable energy sources duly integrated in the overall energy system design; with consideration of active and passive aspects in building design including thermal performance of building envelope.
- g) Rain water harvesting, and use of appropriate building materials considering aspects like energy consumption in production, transportation and utilization, recyclability, etc for promoting sustainable development.
- h) Requisite mandatory provisions for handicapped persons.

- j) Acoustical controls for buildings and the surroundings.
- k) Promotion of artwork in buildings, specially buildings of importance.
- m) Due cognizance of recommendations of the Archeological Survey of India with regard to national monuments and construction in archeologically important sites.
- n) Due cognizance of relevant provisions of applicable coastal zone regulation act.
- p) Conservation of heritage structures and areas.
- q) Environmental and social impact analysis.
- r) Design of services with emphasis on aspects of energy efficiency, environment friendliness and maintainability.
- s) Integrated waste management.
- t) Voice and data communication, automation of building services, and intelligent building; use of security and surveillance system in important and sensitive buildings, such as, access control for the people as well as for vehicle.
- u) Interlinking of fire alarm system, fire protection system, security system, ventilation, electrical systems, etc.
- v) Analysis of emergency power, standby power requirement and captive power systems.
- w) Cost optimization through techniques like value engineering.
- y) Adoption of innovative technologies giving due consideration to constructability and quality aspects.
- z) Instrumentation of buildings and monitoring and use of information so generated to effect improvements in planning and design of future building projects.

6 CONSTRUCTION/EXECUTION (ACTUALIZATION)

6.1 The main functions of the teams (*see 4.2*) constituted for Project Management/Construction Management may be, to :

- a) specify criteria for selection of constructors;
- b) specify quality control, quality audit system and safety system;
- c) short-list constructors;
- d) have pre-bid meetings with the intending constructors;
- e) receive and evaluate tenders;
- f) select constructors;
- g) execution and supervision;
- h) monitor quality, time and cost control;

- j) prepare/certify the completion (as-built) drawings; and
- k) ensure availability of operation manuals for field use.

6.2 Apart from the specific provisions laid down in the concerned Parts/Sections of the Code, the following considerations, as may be applicable to the project concerned, shall be given due attention:

- a) Adopting scientific principles of construction management, quality management, cost and time control.
- b) Engagement of executing and supervising agencies, which meet the specified norms of skills, specialization, experience, resourcefulness, etc for the work.
- c) Ensuring inter-disciplinary co-ordination during construction.
- d) Contract management and techno-legal aspects.
- e) Completion, commissioning and trial run of installations/equipments and their operation and maintenance through the suppliers/other teams, where necessary.
- f) Make available shop drawings as well as as-built drawings for the building and services.
- g) Arrange all maintenance and operation manual from the concerned suppliers/manufacturers.

6.3 The team of professionals (*see 4.2*) shall work and monitor the project activities for successful construction/execution of the project with regard to cost, time, quality and safety.

7 OPERATION AND MAINTENANCE

7.1 The team of professionals (*see 4.3*) shall set up a

system of periodic maintenance and upkeep of constructed buildings.

7.2 The operation and maintenance team shall be responsible for preparation/application of operation and maintenance manual, and draw maintenance schedule/frequencies and guidelines for maintenance personnel. Apart from the specific provisions laid down in concerned Parts/Sections of the Code, the following, as may be applicable to the project concerned shall additionally be taken into account:

- a) Periodic validation of buildings by competent professionals through inspection of the buildings in respect of structural safety and safety of electrical and other installations and ensuring that all fire safety equipments/systems are in proper working condition.
- b) Preparation of preventive maintenance schedules for all installations in the building and strictly following the same; the record of the preventive maintenance to be properly kept.
- c) Ensuring inter-disciplinary co-ordination during maintenance and repairs; deployment of trained personnel with multi-disciplinary skills to be encouraged.
- d) Condition survey of structures and installations, identification of distress of various elements and initiating plans for rehabilitation/retrofitting well in time.

7.3 The proposals for rehabilitation/retrofitting should be prepared after detailed investigations through visual inspection, maintenance records and testing as required and got executed through specialized agencies under the guidance and supervision of competent professionals.

ANNEX A

(Clause 3.2)

BRIEF DETAILS OF THE COVERAGE OF VARIOUS PROVISIONS UNDER DIFFERENT OTHER PARTS/SECTIONS OF THIS CODE

A-1 PART 1 DEFINITIONS

It lists the terms appearing in all the Parts/Sections of the Code. However, some common definitions are reproduced in this Part also.

A-2 PART 2 ADMINISTRATION

It covers the administrative aspects of the Code, such as applicability of the Code, organization of building department for enforcement of the Code, procedure for obtaining development and building permits, and responsibility of the owner and all professionals involved in the planning, design and construction of the building.

A-3 PART 3 DEVELOPMENT CONTROL RULES AND GENERAL BUILDING REQUIREMENTS

It covers the development control rules and general building requirements for proper planning and design at the layout and building level to ensure health safety, public safety and desired quality of life.

A-4 PART 4 FIRE AND LIFE SAFETY

It covers the requirements for fire prevention, life safety in relation to fire, and fire protection of buildings. The Code specifies planning and construction features and fire protection features for all occupancies that are necessary to minimize danger to life and property.

A-5 PART 5 BUILDING MATERIALS

It covers the requirements of building materials and components, and criteria for accepting new or alternative building materials and components.

A-6 PART 6 STRUCTURAL DESIGN

This Part through its seven sections provides for structural adequacy of buildings to deal with both internal and external environment, and provide guidance to engineers/structural engineers for varied usage of material/technology types for building design.

A-6.1 Section 1 Loads, Forces and Effects

It covers basic design loads to be assumed in the design of buildings. The live loads, wind loads, seismic loads, snow loads and other loads, which are specified therein, are minimum working loads which should be taken into consideration for purposes of design.

A-6.2 Section 2 Soils and Foundations

It covers structural design (principles) of all building foundations, such as, raft, pile and other foundation systems to ensure safety and serviceability without exceeding the permissible stresses of the materials of foundations and the bearing capacity of the supporting soil.

A-6.3 Section 3 Timber and Bamboo

A-6.3.1 Section 3A Timber

It covers the use of structural timber in structures or elements of structures connected together by fasteners/ fastening techniques.

A-6.3.2 Section 3B Bamboo

It covers the use of bamboo for constructional purposes in structures or elements of the structure, ensuring quality and effectiveness of design and construction using bamboo. It covers minimum strength data, dimensional and grading requirements, seasoning, preservative treatment, design and jointing techniques with bamboo which would facilitate scientific application and long-term performance of structures. It also covers guidelines so as to ensure proper procurement, storage, precautions and design limitations on bamboo.

A-6.4 Section 4 Masonry

It covers the structural design aspects of unreinforced load bearing and non-load bearing walls, constructed using various bricks, stones and blocks permitted in accordance with this Section. This, however, also covers provisions for design of reinforced brick and reinforced brick concrete floors and roofs. It also covers guidelines regarding earthquake resistance of low strength masonry buildings.

A-6.5 Section 5 Concrete

A-6.5.1 Section 5A Plain and Reinforced Concrete

It covers the general structural use of plain and reinforced concrete.

A-6.5.2 Section 5B Prestressed Concrete

It covers the general structural use of prestressed concrete. It covers both work carried out on site and the manufacture of precast prestressed concrete units.

A-6.6 Section 6 Steel

It covers the use of structural steel in general building construction including the use of hot rolled steel sections and steel tubes.

A-6.7 Section 7 Prefabrication, Systems Building and Mixed/Composite Construction

A-6.7.1 Section 7A Prefabricated Concrete

It covers recommendations regarding modular planning, component sizes, prefabrication systems, design considerations, joints and manufacture, storage, transport and erection of prefabricated concrete elements for use in buildings and such related requirements for prefabricated concrete.

A-6.7.2 Section 7B Systems Building and Mixed/Composite Construction

It covers recommendations regarding modular planning, component sizes, joints, manufacture, storage, transport and erection of prefabricated elements for use in buildings and such related requirements for mixed/composite construction.

A-7 PART 7 CONSTRUCTIONAL PRACTICES AND SAFETY

It covers the constructional planning, management and practices in buildings; storage, stacking and handling of materials and safety of personnel during construction operations for all elements of a building and demolition of buildings. It also covers guidelines relating to maintenance management, repairs, retrofitting and strengthening of buildings. The objective can be best achieved through proper coordination and working by the project management and construction management teams.

A-8 PART 8 BUILDING SERVICES

This Part through its five elaborate sections on utilities provides detailed guidance to concerned professionals/utility engineers for meeting necessary functional requirements in buildings.

A-8.1 Section 1 Lighting and Ventilation

It covers requirements and methods for lighting and ventilation of buildings.

A-8.2 Section 2 Electrical and Allied Installations

It covers the essential requirements for electrical and allied installations in buildings to ensure efficient use of electricity including safety from fire and shock. This Section also includes general requirements relating to lightning protection of buildings.

A-8.3 Section 3 Air Conditioning, Heating and Mechanical Ventilation

This Section covers the design, construction and installation of air conditioning and heating systems and equipment installed in buildings for the purpose of providing and maintaining conditions of air temperature, humidity, purity and distribution suitable for the use and occupancy of the space.

A-8.4 Section 4 Acoustics, Sound Insulation and Noise Control

It covers requirements and guidelines regarding planning against noise, acceptable noise levels and the requirements for sound insulation in buildings with different occupancies.

A-8.5 Section 5 Installation of Lifts and Escalators

It covers the essential requirements for the installation, operation, maintenance and also inspection of lifts (passenger lifts, goods lifts, hospital lifts, service lifts and dumb-waiter) and escalators so as to ensure safe and satisfactory performance.

A-9 PART 9 PLUMBING SERVICES

This Part through its two sections gives detailed guidance to concerned professionals/plumbing engineers with regard to plumbing and other related requirements in buildings.

A-9.1 Section 1 Water Supply, Drainage and Sanitation (Including Solid Waste Management)

It covers the basic requirements of water supply for residential, business and other types of buildings, including traffic terminal stations. This Section also deals with general requirements of plumbing connected to public water supply and design of water supply systems.

It also covers the design, layout, construction and maintenance of drains for foul water, surface water and sub-soil water and sewage; together with all ancillary works, such as connections, manholes and inspection chambers used within the building and from building to the connection to a public sewer, private sewer, individual sewage-disposal system, cess-pool, soakaway or to other approved point of disposal/treatment work. It also includes the provisions on solid waste management.

A-9.2 Section 2 Gas Supply

It covers the requirements regarding the safety of persons and property for all piping uses and for all types of gases used for fuel or lighting purposes in buildings.

A-10 PART 10 LANDSCAPING, SIGNS AND OUTDOOR DISPLAY STRUCTURES

A-10.1 Section 1 Landscape Planning and Design

It covers requirements of landscape planning and design with the view to promoting quality of outdoor built environment and protection of land and its resources.

A-10.2 Section 2 Signs and Outdoor Display Structures

It covers the requirements with regard to public safety, structural safety and fire safety of all signs and outdoor display structures including the overall aesthetical aspects of imposition of signs and outdoor display structures in the outdoor built environment.

NATIONAL BUILDING CODE OF INDIA

PART 2 ADMINISTRATION

BUREAU OF INDIAN STANDARDS

CONTENTS

FOREWORD	...	3
SECTION 1 GENERAL		
1 SCOPE	...	5
2 TERMINOLOGY	...	5
3 APPLICABILITY OF THE CODE	...	6
4 INTERPRETATION	...	7
5 ALTERNATIVE MATERIALS, METHODS OF DESIGN AND CONSTRUCTION, AND TESTS	...	7
SECTION 2 ORGANIZATION AND ENFORCEMENT		
6 DEPARTMENT OF BUILDINGS	...	7
7 POWER AND DUTIES OF TEAM OF BUILDING OFFICIALS	...	8
8 BOARD OF APPEALS	...	9
9 VIOLATIONS AND PENALTIES	...	9
10 POWER TO MAKE RULES	...	9
SECTION 3 PERMIT AND INSPECTION		
11 DEVELOPMENT/BUILDING PERMIT	...	9
12 APPLICATION FOR DEVELOPMENT/BUILDING PERMIT	...	10
13 RESPONSIBILITIES AND DUTIES OF THE OWNER	...	15
14 INSPECTION, OCCUPANCY PERMIT AND POST-OCCUPANCY INSPECTION	...	15
15 UNSAFE BUILDING	...	16
16 DEMOLITION OF BUILDING	...	16
17 VALIDITY	...	17
18 ARCHITECTURAL CONTROL	...	17
ANNEX A GUIDE FOR THE QUALIFICATIONS AND COMPETENCE OF PROFESSIONALS	...	18
ANNEX B FORM FOR FIRST APPLICATION TO DEVELOP, ERECT, RE-ERECT OR TO MAKE ALTERATION IN ANY PLACE IN A BUILDING	...	20
ANNEX C FORM FOR CERTIFICATE FOR STRUCTURAL DESIGN SUFFICIENCY	...	21
ANNEX D FORM FOR SUPERVISION	...	21
ANNEX E FORM FOR SANCTION OR REFUSAL OF DEVELOPMENT/ BUILDING PERMIT	...	22
ANNEX F FORM FOR NOTICE FOR COMMENCEMENT	...	22
ANNEX G FORM FOR CERTIFICATE FOR EXECUTION OF WORK AS PER STRUCTURAL SAFETY REQUIREMENTS	...	23
ANNEX H FORM FOR COMPLETION CERTIFICATE	...	23
ANNEX J FORM FOR OCCUPANCY PERMIT	...	24

FOREWORD

A need for codifying and unifying administrative provisions in different development control rules and building byelaws had been felt, particularly in regard to the applicability of the Code, desirable qualifications for the enforcing Authority and the representative of the owner and responsibilities and duties of the Authority and the owner.

It is expected that the town and country planning department will co-ordinate the administrative provisions of this Part and the same given in the State Town and Country Planning Acts.

This Part recommends the setting up of a 'Board of Appeal'. The 'Board of Appeal' gives the owner/architect/engineer an opportunity to defend the schemes which are based on conventional or new methods of design and construction or using new materials, which have been otherwise rejected by the Authority.

This Part also emphasizes the need for setting up an Arts Commission for metropolitan areas to safeguard existing aesthetics in the event of new schemes proposed for buildings of public importance or buildings coming up in an important area near historic/monumental buildings. The Commission can assist the civic authorities in reviewing plans for development from the stand point of assuring good taste and regard for often threatened natural beauties. The Commission can serve as a means whereby by the government and public bodies and individuals could get advice on artistic questions in connection with building schemes.

The first version of this Part was brought out in 1970, which was subsequently revised in 1983. As a result of implementing 1970 version of this Part in rewriting building byelaws and development control rules of some municipal corporations and municipalities, some useful suggestions were emerged. These were incorporated in the first revision to the extent possible. The significant changes in 1983 version of this Part included the new administrative provisions related to development control rules, additional information to be furnished/indicated in the building plan for multi-storeyed and special buildings and modified provisions regarding submission of building plans by Government Departments to the Authority.

In this second revision, number of modifications have been incorporated based on the experience gained over the years specially in view of different techno-administrative and techno-legal regime encountered in various situations faced. Specially the provisions of this Part have been thoroughly reviewed in the context of the natural calamities faced by the country, such as the devastating earthquake in Gujarat in the year 2001, and provisions have been accordingly modified to further ensure structural adequacy of the buildings. In this context, structural design of buildings in accordance with the provisions of the Code and construction and supervision thereof by competent professionals to ensure structural safety have been given due importance in this revision. Other significant modifications incorporated include:

- a) Modifications in the definitions of certain terms;
- b) Inclusion of the concept of team of building officials;
- c) Inclusion of provision of single window approach for permit for all services;
- d) Inclusion of provisions regarding computerization of approval processes for building permits;
- e) Inclusion of provision to certify safety of buildings against natural disaster by engineer/structural engineer and owner;
- f) Inclusion of provision of two stage permit for high rise residential buildings and special buildings;
- g) Provisions regarding inspection of completed and occupied building by the Authority from safety point of view have been made comprehensive;
- h) Inclusion of provision empowering engineers/architects for sanctioning plans of residential buildings up to 500 m²;
- j) Provisions for architectural control to effectively take care of the urban aesthetics, have been modified; and
- k) Inclusion of landscape architect and urban designer among the registered professionals for the concerned applicable works.

The Sectional Committee responsible for revision of the Code has examined the use of the words 'surveyor/building surveyor/supervisor', etc under various building bye-laws with varying qualifications in different states. It has been decided not to use the generic word 'surveyor' or such other words. The Sectional Committee has, on the other hand recommended association of various professionals for various job responsibilities depending upon their qualifications/competence.

Also, it is noted that the words 'licencing/licensed, etc' are in use by local bodies in different states. The Sectional Committee, however, decided for use of words 'registration/registered, etc' for the same, which may now be adopted uniformly. The registration requirements of professionals are given in Annex A.

NATIONAL BUILDING CODE OF INDIA

PART 2 ADMINISTRATION

SECTION 1 GENERAL

1 SCOPE

This Part covers the administrative aspects of the Code, such as applicability of the Code, organization of building department for enforcement of the Code, procedure for obtaining development and building permits, and responsibility of the owner.

NOTE — This Code is called the National Building Code of India, hereinafter referred to as 'the Code'.

2 TERMINOLOGY

2.0 For the purpose of this part, the following definitions shall apply.

2.1 Accessory Use — Any use of the premises subordinate to the principal use and customarily incidental to the principal use.

2.2 Alteration — A change from one type of occupancy to another, or a structural change, such as an addition to the area or height, or the removal of part of a building, or any change to the structure, such as the construction of, cutting into or removal of any wall, partition, column, beam, joist, floor or other support, or a change to or closing of any required means of ingress or egress or a change to the fixtures or equipment.

2.3 Approved — Approved by the Authority having jurisdiction.

2.4 Authority Having Jurisdiction — The Authority which has been created by a statute and which, for the purpose of administering the Code/Part, may authorize a committee or an official or an agency to act on its behalf; hereinafter called the 'Authority'.

2.5 Building — Any structure for whatsoever purpose and of whatsoever materials constructed and every part thereof whether used as human habitation or not and includes foundation, plinth, walls, floors, roofs, chimneys, plumbing and building services, fixed platforms, verandah, balcony, cornice or projection, part of a building or anything affixed thereto or any wall enclosing or intended to enclose any land or space and signs and outdoor display structures. Tents/*SHAMIANAHS*, tarpaulin shelters, etc, erected for temporary and ceremonial occasions with the permission of the Authority shall not be considered as building.

2.6 Building, Height of — The vertical distance measured, in the case of flat roofs from the average level of the ground around and contiguous to the building or as decided by the Authority to the terrace

of last livable floor of the building adjacent to the external walls; and in the case of pitched roofs, up to the point where the external surface of the outer wall intersects the finished surface of the sloping roof, and in the case of gables facing the road, the midpoint between the eaves level and the ridge. Architectural features serving no other function except that of decoration shall be excluded for the purpose of measuring heights.

2.7 Building Line — The line up to which the plinth of a building adjoining a street or an extension of a street or on a future street may lawfully extend. It includes the lines prescribed, if any, in any scheme. The building line may change from time-to-time as decided by the Authority.

2.8 Conversion — The change of occupancy or premises to any occupancy or use requiring additional occupancy permit.

2.9 Development — 'Development' with grammatical variations means the carrying out of building, engineering, mining or other operations in, or over, or under land or water, or in the use of any building or land, and includes redevelopment and layout and subdivision of any land; and 'to develop' shall be construed accordingly.

2.10 Drain — A conduit or channel for the carriage of storm water, sewage, waste water or other water-borne wastes in a building drainage system.

2.11 Drainage — The removal of any liquid by a system constructed for the purpose.

2.12 Occupancy or Use Group — The principal occupancy for which a building or a part of a building is used or intended to be used; for the purposes of classification of a building according to occupancy, an occupancy shall be deemed to include the subsidiary occupancies which are contingent upon it.

2.13 Occupier — Occupier includes any person for the time being, paying or liable to pay rent or any portion of rent of the building in respect of which the ward is used, or compensation or premium on account of the occupation of such building and also a rent-free tenant, but does not include a lodger, and the words 'occupy' and 'occupation' do not refer to the lodger.

An owner living in or otherwise using his own building shall be deemed to be the occupier thereof.

2.14 Operational Construction/Installation — A construction/installation put up by Government Departments for operational purposes (*see 12.1.1.1*).

2.15 Owner — Person or body having a legal interest in land and/or building thereon. This includes free holders, leaseholders or those holding a sub-lease which both bestows a legal right to occupation and gives rise to liabilities in respect of safety or building condition.

In case of lease or sub-lease holders, as far as ownership with respect to the structure is concerned, the structure of a flat or structure on a plot belongs to the allottee/lessee till the allotment/lease subsists.

2.16 Permit — A permission or authorization in writing by the Authority to carry out work regulated by the Code.

2.17 Registered Architect, Engineer, Structural Engineer, Supervisor, Town Planner, Landscape Architect, Urban Designer — A qualified architect, engineer, structural engineer, supervisor, town planner, landscape architect or urban designer who has been registered by the Authority or by the body governing such profession and constituted under a statute, as may be applicable. The registration requirements of these professionals shall be as given in Annex A.

NOTES

1 Unless specified otherwise, the word 'engineer' shall mean 'civil engineer' or 'architectural engineer'.

2 The word 'licencing/licensed, etc' if used by the Authority in the above context shall be deemed to mean 'registration/registered', etc.

2.18 Road — See 2.25.

2.19 Road Line — See 2.27.

2.20 Room Height — The vertical distance measured from the finished floor surface to the finished ceiling surface. Where a finished ceiling is not provided, the underside of the joists or beams or tie beams shall determine the upper point of measurement for determining the head room.

2.21 Sanctioned Plan — The set of plans and specifications submitted in connection with a building or development and duly approved and sanctioned by the Authority.

2.22 Service Road — A road/lane provided at the rear or side of a plot for service purposes.

2.23 Set-back Line — A line usually parallel to the plot boundaries and laid down in each case by the Authority, beyond which nothing can be constructed towards the site boundaries.

2.24 Site (Plot) — A parcel (piece) of land enclosed by definite boundaries.

2.25 Street — Any means of access, namely, highway, street, lane, pathway, alley, stairway, passageway,

carriageway, footway, square, place or bridge, whether a thoroughfare or not, over which the public have a right of passage or access or have passed and had access uninterruptedly for a specified period, whether existing or proposed in any scheme and includes all bunds, channels, ditches, storm-water drains, culverts, sidewalks, traffic islands, roadside trees and hedges, retaining walls, fences, barriers and railings within the street lines.

2.26 Street Level or Grade — The officially established elevation or grade of the centre line of the street upon which a plot fronts and if there is no officially established grade, the existing grade of the street at its mid-point.

2.27 Street Line — The line defining the side limits of a street.

2.28 To Erect — To erect a building means:

- a) to erect a new building on any site whether previously built upon or not;
- b) to re-erect any building of which portions above the plinth level have been pulled down, burnt or destroyed.

2.29 Unsafe Building — Buildings which are structurally and constructionally unsafe or insanitary or not provided with adequate means of egress or which constitute a fire hazard or are otherwise dangerous to human life or which in relation to existing use constitute a hazard to safety or health or public welfare, by reason of inadequate maintenance, dilapidation or abandonment.

3 APPLICABILITY OF THE CODE

3.1 All Parts of the Code and their sections shall apply to all buildings described in 3.2 to 3.8, as may be applicable.

3.2 Where a building is erected, the Code applies to the design and construction of the building.

3.3 Where the whole or any part of the building is removed, the Code applies to all parts of the building whether removed or not.

3.4 Where the whole or any part of the building is demolished, the Code applies to any remaining part and to the work involved in demolition.

3.5 Where a building is altered (*see 12.4 and 12.4.1*), the Code applies to the whole building whether existing or new except that the Code applies only to part if that part is completely self-contained with respect to facilities and safety measures required by the Code.

3.6 Where the occupancy of a building is changed, the Code applies to all parts of the building affected by the change.

3.7 Where development of land is undertaken the Code applies to the entire development of land.

3.8 Existing Buildings/Development

Nothing in the Code shall require the removal, alteration or abandonment, nor prevent continuance of the use or occupancy of an existing building/development, unless in the opinion of the Authority, such building/development constitutes a hazard to the safety of the adjacent property or the occupants of the building itself.

4 INTERPRETATION

4.1 The heading which appears at the beginning of a clause or sub-clause of the Code shall be deemed to be a part of such clause or sub-clause respectively.

4.2 The use of present tense includes the future tense, the masculine gender includes the feminine and the neuter, the singular number includes the plural and the plural includes the singular. The word 'person' includes a corporation as well as an individual; writing includes printing and typing and 'signature' includes thumb impression made by a person who cannot write if his name is written near to such thumb impression.

5 ALTERNATIVE MATERIALS, METHODS OF DESIGN AND CONSTRUCTION, AND TESTS

5.1 The provisions of the Code are not intended to prevent the use of any material or method of design or construction not specifically prescribed by the Code, provided any such alternative has been approved.

5.2 The Authority may approve any such alternative provided it is found that the proposed alternative is satisfactory and conforms to the provisions of relevant parts regarding material, design and construction and that material, method, or work offered is, for the purpose intended, at least equivalent to that prescribed in the Code in quality, strength, compatibility, effectiveness, fire and water resistance, durability and safety.

5.3 Tests

Whenever there is insufficient evidence of compliance with the provisions of the Code or evidence that any material or method of design or construction does not conform to the requirements of the Code or in order to substantiate claims for alternative materials, design or methods of construction not specifically prescribed in the Code, the Authority may require tests sufficiently in advance as proof of compliance. These tests shall be made by an approved agency at the expense of the owner.

5.3.1 Test methods shall be specified by the Code for the materials or design or construction in question. If

there are no appropriate test methods specified in the Code, the Authority shall determine the test procedure. For methods of test for building materials, reference may be made to Part 5 Building Materials.

5.3.2 Copies of the results of all such tests shall be retained by the Authority for a period of not less than two years after the acceptance of the alternative material.

SECTION 2 ORGANIZATION AND ENFORCEMENT

6 DEPARTMENT OF BUILDINGS

6.1 The department of buildings shall be created by the Authority and a team of building officials shall be appointed to carry out work of such department.

6.2 Appointment of Team of Building Officials

The team of building officials shall be appointed by the Authority. The team shall comprise officials drawn from concerned disciplines such as engineer, architect, town planner, landscape architect and urban designer as may be decided by the Authority. For scrutiny of layout plans of plots of one hectare and above in metro cities and two hectares and above in other places, town planner shall be part of the team of building officials. For plots of five hectares and above, landscape architect shall also be part of the team. An urban designer shall also be required to be the part of team of building officials for examining proposals on integrated urban design and development for residential/business/institutional and assembly building.

NOTE — Metro cities are cities with population more than 1 000 000.

6.3 Organization

In the department of buildings, such number of officers, technical assistants, inspectors and other employees shall be appointed to assist the team of building officials as shall be necessary for the administration of the Code and as authorized by the Authority.

6.4 Delegation of Powers

The Authority may designate one of the building officials who shall exercise all the powers of the team of building officials. The work of the team of building officials may be outsourced to competent professional/agency/group as may be deemed necessary.

6.5 Qualification of Building Officials

The qualification of building officials scrutinizing the plans and carrying out inspection of buildings shall not in any case be less than those prescribed in Annex A.

6.5.1 In small local bodies having insufficient resources to appoint such officials with the above

qualifications, two or three such bodies contiguously located could join together and share the services of one team of building officials.

6.6 Qualifications of Assistant

No person shall be appointed as Assistant unless he has got the qualifications prescribed in Annex A for a registered Supervisor.

6.7 Restriction on Employees

No official or employee connected with the department of buildings except one whose only connection is that of a member of the Board of Appeals, established under 8 shall be engaged directly or indirectly in a work connected with the furnishing of labour, materials or appliances for the construction, alteration or maintenance of a building, or the preparation of plans or of specifications thereof unless he is the owner of building; nor shall such official or employee engage in any work which conflicts with his official duties or with the interests of the Department.

6.8 Records

Proper records of all applications received, permits and orders issued, inspections made shall be kept and copies of all papers and documents connected with the administration of its duties shall be retained and all such records shall be open to public inspection at all appropriate times.

7 POWER AND DUTIES OF TEAM OF BUILDING OFFICIALS

7.0 The team of building officials shall enforce all the provisions of the Code and shall act on any question relative to the mode or manner of construction and the materials to be used in the erection, addition, alteration, repair, removal, demolition, installation of service equipment and the location, use, occupancy and maintenance of all buildings except as may otherwise be specifically provided.

7.1 Application and Permits

The team of building officials shall receive all applications and issue permits (*see 12.10*) for the erection and alteration of buildings and examine the premises for which such permits have been issued and enforce compliance with the Code.

7.2 Building Notices and Orders

The team of building officials shall issue all necessary notices or orders to remove illegal or unsafe conditions, to require the necessary safeguards during construction, to require adequate exit facilities in existing buildings and to ensure compliance with all the requirements of safety, health and general welfare of the public as included in the Code.

7.3 Right of Entry

Upon presentation of proper credentials and with advance notice, the team of building officials or its duly authorized representative may enter at any reasonable time any building or premises to perform any duty imposed upon him by the Code.

7.4 Inspection

The team of building officials shall make all the required inspections or it may accept reports of inspections of authoritative and recognized services or individuals; and all reports of inspections shall be in writing and certified by a responsible officer of such authoritative service or by the responsible individual or engage any such expert opinion as he may deem necessary to report upon unusual technical issues that may arise, subject to the approval of the Authority.

7.5 Construction Not According to Plan

Should the team of building officials determine at any stage that the construction is not proceeding according to the sanctioned plan or is in violation of any of the provisions of the Code, or any other applicable Code Regulation, Act or Byelaw, it shall notify the owner, and all further construction shall be stayed until correction has been effected and approved.

7.5.1 Should the owner fail to comply with the requirements at any stage of construction, the Authority shall issue a notice to the owner asking explanation for non-compliance. If the owner fails to comply within 14 days from the date of receiving the notice, the Authority shall be empowered to cancel the building permit issued and shall cause notice of such cancellation to be securely pasted upon the said construction, if the owner is not traceable at his address given in the notice. Pasting of such a notice shall be considered sufficient notification of cancellation to the owner thereof. No further work shall be undertaken or permitted upon such construction until a valid building permit thereafter has been issued. If the owner, in violation of the notice for cancellation, continues the construction, the Authority may take all necessary means to stop such work and further appropriate actions including demolitions. The owner shall, however, have right to appeal against cancellation of permit, to the board of appeal, within a stipulated period, as may be decided by the Authority.

7.6 Modification

Wherever practical difficulties are involved in carrying out any provision of the Code, the team of building officials may vary or modify such provisions upon application of the owner or his representative provided the spirit and intent of the Code shall be observed and public welfare and safety be assured. The application

for modification and the final decision of the team of building officials shall be in writing and shall be officially recorded with the application for the permit in the permanent records of the Department of Building Inspection.

7.7 Occupancy Violations

Wherever any building is being used contrary to provisions of the Code, the team of building officials may order such use discontinued and the building or portion thereof, vacated by the notice served on any person, causing such use to be discontinued. Such person shall discontinue the use within 10 days after receipt of such notice or make the building or portion thereof, comply with the requirements of the Code.

8 BOARD OF APPEALS

In order to determine the suitability of alternative materials or methods of design or construction and to provide for reasonable interpretation of the provisions of the Code or in the matter of dispute relating to an ongoing construction vis-a-vis the sanctioned plan, a Board of Appeals consisting of members who are qualified by experience and training and to pass judgement upon matters pertaining to building construction, shall be appointed by the Authority. A representative of the team of building officials shall be an *ex-officio* member and shall act as secretary to the Board. The Board shall adopt reasonable rules and regulations for conducting its investigations and shall render all decisions and findings in writing to the team of building officials with a duplicate copy to the appellant and may recommend such modifications as are necessary.

9 VIOLATIONS AND PENALTIES

9.1 Offences and Penalties

9.1.1 Any person who contravenes any of the provisions of the Code or any requirements of obligations imposed on him by virtue of the Code, or who interferes with or obstructs any person in the discharge of his duties, shall be guilty of an offence and the Authority shall levy suitable penalty or take other actions as per the Code (*see also 7.5 and 15*).

NOTE — The penalty may be in the form of collection of arrears of tax.

9.1.2 The buildings/developments violating any applicable statutory rules shall be demolished/brought within the limits as prescribed in such rules at the expense of the owner. The buildings coming up in the vicinity of an aerodrome in violation of the height restriction laid down by the Directorate General of Civil Aviation shall be accordingly demolished/brought within the limits prescribed by DGCA rules.

9.1.3 The registered architect, engineer, structural engineer, supervisor, town planner, landscape architect, urban designer and utility service engineer (*see Annex A*) responsible for the services rendered for supervision of the construction/development and for the completion certificate; in the event of violation of the provisions of the Code, shall be liable to penalties as prescribed by the Authority including cancellation of registration done by it or make such recommendation to the statutory body governing such profession.

9.2 Further Obligation of Offender

The conviction of any person for an offence under the provision of **9.1** shall not relieve him from the duty of carrying out the requirements or obligations imposed on him by virtue of the provisions of the Code; and if such requirements or obligations are not complied with in accordance with an order made under provisions of **9.1**, the Authority under the provisions of the Code may, if necessary and advisable, enter upon the premises in respect of which a conviction has been made and carry out at the expense of the convicted person, the requirements or obligations referred to in the said order and the expense, if not paid on demand, may be recovered with cost in a court.

9.3 Conviction No Bar to Further Prosecution

The conviction of any person under the provisions of this part for failing to comply with any of the said requirements or obligations shall not operate as a bar to further prosecution under this part for any subsequent failure on the part of such person to comply.

10 POWER TO MAKE RULES

The Authority may make rules for carrying out the provisions and intentions of the Code provided that any rule shall not be in direct/indirect conflict or nullify/dilute any of the provisions of the Code.

SECTION 3 PERMIT AND INSPECTION

11 DEVELOPMENT/BUILDING PERMIT

11.1 Permit Required

No person shall carry out any development, erect, re-erect or make alterations or demolish any building or cause the same to be done without first obtaining a separate permit for each such development/building from the Authority. No permits shall, however, be required for works referred to in **12.1.1.1** and **12.4.1**.

11.1.1 The development/building permit shall take into cognizance the provisions under the relevant Town Planning Act/Development Act/Municipal Act/any other applicable statutes for layout, building plans, water supply, sewerage, drainage, electrification, etc, as provided in the said Act/statute. Also, if so directed

by the Authority, the permit shall take care of the need for landscape development plan incorporating rain-water harvesting proposals in the layout and building plans.

11.1.2 Specific approvals shall be obtained from Civil Aviation Authorities, Fire Services Department (in case the building proposed is 15 m and above), Pollution Control Board, designated authorities under Factories Act/Cinema Regulation Act, Urban Arts Commission, designated Coastal Regulation Zone Authority, Archeological Survey of India, Heritage Committee and any such other authority as may be applicable.

11.1.3 In order to facilitate clearance from above bodies with the concept of single window clearance approach and thereby final approval by the Authority within the stipulated time frame, the Authority may constitute a Development/Building Permit Approval Committee consisting of representative of the team of building officials, representatives of all bodies/organizations from whom clearance for development/building permit clearance is required.

Recommendations from such Committee shall be summarily utilized by the team of building officials in sanctioning process. The Committee may meet once in 15/30 days depending upon the work load. The first response/invalid notice/non-compliance intimation shall be issued by the Authority to the owner within 30 days of submission of the plans to the Authority.

11.1.4 The Authority shall permit a registered architect/engineer to approve the building proposals including plans, and certify completion of building for issue of related regulatory building permits and occupancy certificate for residential buildings designed by self or otherwise, on plot size up to 500 m². The responsibility of compliance with respect to provisions of Code shall rest with the registered architect/engineer. However, the plans shall be required to be submitted to the Authority for information and record.

NOTE — Where the experience clearly shows that satisfactory building permit activities are being carried out through the above empowerment of professionals, the Authority may extend such provision for larger areas and other building occupancies.

11.2 Pre-Code Development/Building Permit

If any development/building, permit for which had been issued before the commencement of the Code, is not wholly completed within a period of three years from the date of such permit, the said permission shall be deemed to have lapsed and fresh permit shall be necessary to proceed further with the work in accordance with the provisions of the Code.

12 APPLICATION FOR DEVELOPMENT/BUILDING PERMIT

12.1 Notice

Every owner who intends to develop, erect, re-erect or make alterations in any place in a building shall give notice in writing to the Authority of his said intention in the prescribed form (*see* Annex B) and such notice shall be accompanied by plans and statements in triplicate as required under **12.2** and **12.3** except for special buildings (high rise, non-residential) where additional copies may be submitted as desired by the Authority. The Authority shall permit submission of plans/documents in electronic form in addition to hard copy. The Authority should also progressively computerize the approval process.

12.1.1 Regarding submission of plans by Government Departments, the procedure shall be as given in **12.1.1.1** and **12.1.1.2**.

12.1.1.1 The operational construction/installation of the Government, whether temporary or permanent, which is essential for the operation, maintenance, development or execution of any of the following services may be exempted from the point of view of the byelaws:

- a) Railways;
- b) National highways;
- c) National waterways;
- d) Major ports;
- e) Airways and aerodromes;
- f) Posts and telegraphs, telephones, wireless, broadcasting, and other like forms of communications;
- g) Regional grid for electricity;
- h) Defence; and
- j) Any other service which the Central/State Government may, if it is of opinion that the operation, maintenance, development of execution of such service is essential to the life of the community, by notification, declare to be a service for the purpose of this clause.

In case of construction/installation where no approvals are required, the concerned agencies which are exempted from seeking approval shall submit the drawings/plans/details for information and records of the Authority before construction/installation.

12.1.1.2 However, the following construction of the Government departments do not come under the purview of operational construction for the purpose of exemption under **12.1.1.1**:

- a) New residential building (other than gate lodges, quarters for limited essential operational

staff and the like), roads and drains in railway colonies, hospitals, clubs, institutes and schools, in the case of railways; and

- b) A new building, new construction or new installation or any extension thereof in the case of any other services.

12.2 Information Accompanying Notice

The notice shall be accompanied by the key plan, site plan, building plan, services plans, specifications structural sufficiency certificate and certificate of supervision as prescribed in 12.2.2 to 12.2.8.

12.2.1 Sizes of Drawing Sheets and Recommended Notation for Colouring Plans

12.2.1.1 The size of drawing sheets shall be any of those specified in Table 1.

SI No.	Designation	Trimmed Size mm
(1)	(2)	(3)
i)	A0	841 × 1 189
ii)	A1	594 × 841
iii)	A2	420 × 594
iv)	A3	297 × 420
v)	A4	210 × 297
vi)	A5	148 × 210

12.2.1.2 The plans shall be coloured as specified in Table 2.

12.2.2 Key Plan

A key plan drawn to a scale of not less than 1 in 10 000 shall be submitted along with the application for a development/building permit showing the boundary locations of the site with respect to neighbourhood landmarks. The minimum dimension of the key plan shall be not less than 75 mm.

12.2.3 Site Plan

The site plan sent with an application for permit shall be drawn to a scale of not less than 1 in 500 for a site up to one hectare and not less than 1 in 1 000 for a site more than one hectare and shall show:

- the boundaries of the site and of any contiguous land belonging to the owner thereof;
- the position of the site in relation to neighbouring street;
- the name of the streets in which the building is proposed to be situated, if any;
- all existing buildings standing on, over or under the site including service lines;
- the position of the building and of all other buildings (if any) which the applicant intends to erect upon his contiguous land referred to in (a) in relation to:

Table 2 Colouring of Plans

(Clause 12.2.1.2)

SI No.	Item	Site Plan			Building Plan		
		White Plan	Blue Print	Ammonia Print	White Plan	Blue Print	Ammonia Print
(1)	(2)	(3)	(4)	(5)	(6)	(7)	(8)
i)	Plot lines	Thick black	Thick black	Thick black	Thick black	Thick black	Thick black
ii)	Existing street	Green	Green	Green	—	—	—
iii)	Future street, if any	Green dotted	Green dotted	Green dotted	—	—	—
iv)	Permissible building lines	Thick dotted black	Thick dotted black	Thick dotted black	—	—	—
v)	Open spaces	No colour	No colour	No colour	No colour	No colour	No colour
vi)	Existing work	Black (outline)	White	Blue	Black	White	Blue
vii)	Work proposed to be demolished	Yellow hatched	Yellow hatched	Yellow hatched	Yellow hatched	Yellow hatched	Yellow hatched
viii)	Proposed work (see Note 1)	Red filled in	Red	Red	Red	Red	Red
ix)	Drainage and sewerage work	Red dotted	Red dotted	Red dotted	Red dotted	Red dotted	Red dotted
x)	Water supply work	Black dotted thin	Black dotted thin	Black dotted thin	Black dotted thin	Black dotted thin	Black dotted thin

NOTES

- For entirely new construction this need not be done; for extension of an existing work this shall apply.
- For land development, subdivision, layout, suitable colouring notations shall be used which shall be indexed.

- 1) the boundaries of the site and in case where the site has been partitioned, the boundaries of the portion owned by the applicant and also of the portions owned by others;
 - 2) all adjacent street, buildings (with number of storeys and height) and premises within a distance of 12 m of the site and of the contiguous land (if any) referred to in (a); and
 - 3) if there is no street within a distance of 12 m of the site, the nearest existing street;
- f) the means of access from the street to the building, and to all other buildings (if any) which the applicant intends to erect upon his contiguous land referred to in (a);
 - g) space to be left about the building to secure a free circulation of air, admission of light and access for scavenging purposes;
 - h) the width of the street (if any) in front and of the street (if any) at the side or near the buildings;
 - j) the direction of north point relative to the plan of the buildings;
 - k) any physical features, such as wells, drains, etc; and
 - m) such other particulars as may be prescribed by the Authority.

12.2.4 Sub-Division/Layout Plan

In the case of development work, the notice shall be accompanied by the sub-division/layout plan which shall be drawn on a scale of not less than 1 : 500 containing the following:

- a) Scale used and north point;
- b) The location of all proposed and existing roads with their existing/proposed/prescribed widths within the land;
- c) Dimensions of plot along with building lines showing the setbacks with dimensions within each plot;
- d) The location of drains, sewers, public facilities and services, and electrical lines, etc;
- e) Table indicating size, area and use of all the plots in the sub-division/layout plan;
- f) A statement indicating the total area of the site, area utilized under roads, open spaces for parks, playgrounds, recreation spaces for parks, playgrounds, recreation spaces and development plan reservations, schools, shopping and other public places alongwith their percentage with reference to the total

area of the site proposed to be subdivided; and

- g) In case of plots which are subdivided in built-up areas in addition to the above, the means of access to the sub-division from existing streets.

12.2.5 Building Plan and Details

The plan of the buildings and elevations and sections accompanying the notice shall be drawn to a scale of 1 : 100. The plans and details shall:

- a) include floor plans of all floors together with the covered area clearly indicating the size and spacings of all framing members and sizes of rooms and the position of staircases, ramps and liftwells;
- b) show the use or occupancy of all parts of the buildings;
- c) show exact location of essential services, for example, WC, sink, bath and the like;
- d) include at least one elevation from the front showing height of building and rooms and also the height of parapet;
- e) include at least one section through the staircase;
- f) include the structural arrangements with appropriate sections showing type/arrangement of footings, foundations, basement walls; structural load bearing walls, columns and beams, and shear walls; and arrangement/spacing of framing members, floor slabs and roof slabs with the material used for the same;
- g) show all street elevations;
- h) give dimensions of the projected portions beyond the permissible building line;
- j) include terrace plan indicating the drainage and the slope of the roof; and
- k) give indications of the north point relative to the plan.

NOTE — The requirement of 1 : 100 is permitted to be flexible for specific details needed for further illustration; and also for drawings for these in electronic form.

12.2.5.1 Building plan for multi-storeyed/special buildings

For all multi-storeyed buildings which are 15 m or more in height and for special buildings like educational, assembly, institutional, industrial, storage and hazardous and mixed occupancies with any of the aforesaid occupancies having covered area more than 500 m², the building sanction shall be done in two stages.

Stage 1: First stage for planning clearance

The following additional information shall be furnished/indicated in the building plan in addition to the items given in **12.2.5** as applicable:

- a) Access to fire appliances/vehicles with details of vehicular turning circle and clear motorable accessway around the building;
- b) Size (width) of main and alternative staircases along with balcony approach, corridor, ventilated lobby approach;
- c) Location and details of lift enclosures;
- d) Location and size of fire lift;
- e) Smoke stop lobby/door, where provided;
- f) Refuse chutes, refuse chamber, service duct, etc;
- g) Vehicular parking spaces;
- h) Refuse area, if any;
- j) *Details of building services* — Air-conditioning system with position of fire dampers, mechanical ventilation system, electrical services, boilers, gas pipes, etc;
- k) Details of exits including provision of ramps, etc, for hospitals and special risks;
- m) Location of generator, transformer and switchgear room;
- n) Smoke exhauster system, if any;
- p) Details of fire alarm system network;
- q) Location of centralized control, connecting all fire alarm systems, built-in-fire protection arrangements and public address system, etc;
- r) Location and dimensions of static water storage tank and pump room along with fire service inlets for mobile pump and water storage tank;
- s) Location and details of fixed fire protection installations, such as, sprinklers, wet risers, hose-reels, drenchers, etc; and
- t) Location and details of first-aid fire fighting equipments/installations.

Stage 2: Second stage for building permit clearance

After obtaining the sanction for planning (Stage 1) from the Authority, a complete set of structural plans, sections, details and design calculations duly signed by engineer/structural engineer (*see Annex A*) along with the complete set of details duly approved in Stage 1 shall be submitted. The building plans/details shall be deemed sanctioned for the commencement of construction only after obtaining the permit for Stage 2 from the Authority.

12.2.6 Services Plans

The services plans shall include all details of building and plumbing services, and also plans, elevations and sections of private water supply, sewage disposal system and rainwater harvesting system, if any (*see Part 8 'Building Services' and Part 9 'Plumbing Services'*).

12.2.7 Specifications

Specifications, both general and detailed, giving type and grade of materials to be used, duly signed by the registered architect, engineer, structural engineer or supervisor shall accompany the notice (*see Annex B*).

12.2.8 Structural Sufficiency Certificate

The plans shall be accompanied by structural sufficiency certificate in the prescribed form (*see Annex C*) signed by the engineer/structural engineer (*see Annex A*) and the owner jointly to the effect that the building is safe against various loads, forces and effects including due to natural disasters, such as, earthquake, landslides, cyclones, floods, etc as per Part 6 'Structural Design' and other relevant Codes. The engineer/structural engineer shall also have the details to substantiate his design.

12.2.9 Supervision

The notice shall be further accompanied by a certificate in the prescribed form (*see Annex D*) by the registered architect/engineer/structural engineer/supervisor/town planner (*see Annex A*) undertaking the supervision (*see 9.3*).

12.3 Preparation and Signing of Plans

The registered architect/engineer/supervisor/town planner/landscape architect/urban designer/utility service engineer shall prepare and duly sign the plans as per their competence (*see Annex A*) and shall indicate his/her name, address, qualification and registration number as allotted by the Authority or the body governing such profession. The structural plans and details shall also be prepared and duly signed by the competent professionals like registered engineer/structural engineer (*see Annex A*). The plans shall also be duly signed by the owner indicating his address. The type and volume of buildings/development work to be undertaken by the registered professionals may generally be as in Annex A.

12.4 Notice for Alteration only

When the notice is only for an alteration of the building (*see 3.5*), only such plans and statements, as may be necessary, shall accompany the notice.

12.4.1 No notice and building permit is necessary for the following alterations, and the like which do not otherwise violate any provisions regarding general

building requirements, structural stability and fire and health safety requirements of the Code:

- a) Opening and closing of a window or door or ventilator;
- b) Providing intercommunication doors;
- c) Providing partitions;
- d) Providing false ceiling;
- e) Gardening;
- f) White washing;
- g) Painting;
- h) Re-tiling and re-roofing;
- j) Plastering and patch work;
- k) Re-flooring; and
- m) Construction of sunshades on one's own land.

12.5 Fees

No notice as referred to in **12.1** shall be deemed valid unless and until the person giving notice has paid the fees to the Authority and an attested copy of the receipt of such payment is attached with the notice.

NOTE — The fees may be charged as a consolidated fee. In the event of a building/development permit is not issued, the fees so paid shall not be returned to the owner, but he shall be allowed to re-submit it without any fees after complying with all the objections raised by the Authority within a period of one year from the date of rejection after which fresh fees shall have to be paid.

12.6 Duration of Sanction

The sanction once accorded shall remain valid up to three years. The permit shall be got revalidated before the expiration of this period. Revalidation shall be subject to the rules then in force.

12.7 Deviations During Construction

If during the construction of a building any departure (excepting for items as given in **12.4.1**) from the sanctioned plan is intended to be made (*see 7.5*), sanction of the Authority shall be obtained before the change is made. The revised plan showing the deviations shall be submitted and the procedure laid down for the original plan heretofore shall apply to all such amended plans except that the time limit specified in **12.10.2** shall be three weeks in such cases.

12.8 Revocation of Permit

The Authority may revoke any permit issued under the provisions of the Code, wherever there has been any false statement, misrepresentation of any material fact in the application on which the permit was based or violation of building permit or in case of noncompliance thereof, and shall state the reasons for revoking the permit.

12.9 Qualifications of Architects/Engineers/Structural Engineers/Landscape Architect/Urban Designer/Supervisors/Town Planners/Services Personnel

Architects, engineers, structural engineers, landscape architect, urban designer, supervisors and town planners wherever referred in the Code, shall be registered by the Authority or the body governing such profession constituted under a statute, as competent to do the work for which they are employed. A guide for the equivalent technical qualifications and professional experience required for such registration with the Authority is given in Annex A. In case of building and plumbing services, qualifications for engineers for utility services shall be as given in **A-2.8**.

12.9.1 In case the registered professional associated with the preparation and signing of plans or for supervision, is being changed during any stage of building/land development process, the professional shall intimate the Authority in writing about the further non-association with the project.

12.10 Grant of Permit or Refusal

The Authority may either sanction or refuse the plans and specifications or may sanction them with such modifications or directions as it may deem necessary and thereupon shall communicate its decision to the person giving the notice (*see Annex E*).

12.10.1 The building plans for buildings identified in **12.2.5.1** shall also be subject to the scrutiny of the Fire Authority and the sanction through building permit shall be given by the Authority after the clearance from the Fire Authority (*see also 11.1.3*).

12.10.2 If within 30 days of the receipt of the notice under **12.1** of the Code, the Authority fails to intimate in writing to the person, who has given the notice, of its refusal or sanction, the notice with its plans and statements shall be deemed to have been sanctioned; provided the fact is immediately brought to the notice of the Authority in writing by the person who has given notice and having not received any intimation from the Authority within fifteen days of giving such written notice. Subject to the conditions mentioned in this clause, nothing shall be construed to authorize any person to do anything in contravention of or against the terms of lease or titles of the land or against any other regulations, byelaws or ordinance operating on the site of the work.

12.10.3 In the case of refusal, the Authority shall quote the reason and relevant sections of the Code which the plans contravene. The Authority shall as far as possible advise all the objections to the plans and specifications in the first instance itself and ensure that no new

objections are raised when they are resubmitted after compliance of earlier objections.

12.10.4 Once the plan has been scrutinized and objections have been pointed out, the owner giving notice shall modify the plan to comply with the objections raised and re-submit it. The Authority shall scrutinize the re-submitted plan and if there be further objections, the plan shall be rejected.

13 RESPONSIBILITIES AND DUTIES OF THE OWNER

13.1 Neither the granting of the permit nor the approval of the drawings and specifications, nor inspections made by the Authority during erection of the building shall in any way relieve the owner of such building from full responsibility for carrying out the work in accordance with the requirements of the Code (*see 9*).

13.2 Every owner shall:

- a) permit the Authority to enter the building or premises for which the permit has been granted at any reasonable time for the purpose of enforcing the Code;
- b) submit a document of ownership of the site;
- c) obtain, where applicable, from the Authority, permits relating to building, zoning, grades, sewers, water mains, plumbing, signs, blasting, street occupancy, electricity, highways, and all other permits required in connection with the proposed work;
- d) give notice to the Authority of the intention to start work on the building site (*see Annex F*);
- e) give written notice to the Authority intimating completion of work up to plinth level;
- f) submit the certificate for execution of work as per structural safety requirements (*see Annex G*); and give written notice to the Authority regarding completion of work described in the permit (*see Annex H*);
- g) give written notice to the Authority in case of termination of services of a professional engaged by him; and
- h) obtain an occupancy permit (*see Annex J*) from the Authority prior to any:
 - 1) occupancy of the building or part thereof after construction or alteration of that building or part, or
 - 2) change in the class of occupancy of any building or part thereof.

13.2.1 Temporary Occupancy

Upon the request of the holder of the permit, the Authority may issue a temporary certificate of

occupancy for a building or part thereof, before the entire work covered by permit shall have been completed, provided such portion or portions may be occupied safely prior to full completion of building without endangering life or public welfare.

13.3 Documents at Site

13.3.1 Where tests of any materials are made to ensure conformity with the requirements of the Code, records of the test data shall be kept available for inspection during the construction of the building and for such a period thereafter as required by the Authority.

13.3.2 The person to whom a permit is issued shall during construction keep pasted in a conspicuous place on the property in respect of which the permit was issued:

- a) a copy of the building permit; and
- b) a copy of the approved drawings and specifications referred in **12**.

14 INSPECTION, OCCUPANCY PERMIT AND POST-OCCUPANCY INSPECTION

14.1 Generally all construction or work for which a permit is required shall be subject to inspection by the Authority and certain types of construction involving unusual hazards or requiring constant inspection shall have continuous inspection by special inspectors appointed by the Authority.

14.2 Inspection, where required, shall be made within 7 days following the receipt of notification, after which period the owner will be free to continue the construction according to the sanctioned plan. At the first inspection, the Authority shall determine to the best of its ability that the building has been located in accordance with the approved site plans. The final inspection of the completion of the work shall be made within 21 days following the receipt of notification [*see 13.2(f)*] for the grant of occupancy certificate.

14.2.1 The owner/concerned registered architect/engineer/structural engineer/town planner will serve a notice/completion certificate to the Authority that the building has been completed in all respects as per the approved plans. The deviations shall also be brought to the notice of the Authority (with relevant documents). The team of building officials or its duly authorized representative shall then visit the site and occupancy certificate shall be given in one instance.

14.2.2 The occupancy certificate should clearly state the use/type of occupancy of the building. However, the applicant can apply for change of use/occupancy permitted within the purview of the Master Plan/Zonal Plan/Building Byelaws, where so required.

14.3 When inspection of any construction operation reveals than any lack of safety precautions exist, the Authority shall have right to direct the owner to stop the work immediately until the necessary remedial measures to remove the violation of safety precautions are taken.

14.4 Periodic Occupancy Renewal Certificate

14.4.1 For buildings covered in **12.2.5.1** after completion of the building and obtaining the occupancy certificate, periodic inspections of buildings shall be made by the Fire Authority to ensure the fire safety of the building and compliance with the provisions of fire and life safety requirements (*see* Part 4 'Fire and Life Safety'). Periodic occupancy renewal certificate shall be made available by the Authority/Fire Authority which shall also include safekeep of fire fighting installations and equipments for such buildings.

14.4.2 All occupied building and buildings covered under **12.2.5.1** shall also be subjected to periodic physical inspection by a team of multi-disciplinary professionals of local Authority. The work by team of professionals may be outsourced by the Authority to competent professionals as may be deemed necessary. The team shall ensure the compliance of byelaws, natural lighting, ventilation, etc, besides structural and electrical safety. After checking, the team shall be required to give the certificate for above aspects. If any shortcoming/deficiencies or violations are noticed during inspection, the Authority shall ensure the compliance of these within a specified time frame of six months. If not complied with, the building shall be declared unsafe. The period of inspection shall usually be 3 to 5 years but in any case not more than 5 years.

15 UNSAFE BUILDING

15.1 All unsafe buildings shall be considered to constitute danger to public safety and shall be restored by repairs or demolished or dealt with as otherwise directed by the Authority (*see* **15.2** to **15.5**).

15.2 Examination of Unsafe Building

The Authority shall examine or cause to be examined every building reported to be unsafe or damaged, and shall make a written record of such examination.

15.3 Notice to Owner, Occupier

Whenever the Authority finds any building or portion thereof to be unsafe, it shall, in accordance with established procedure for legal notice, give to the owner and occupier of such building written notices stating the defects thereof. This notice shall require the owner or the occupier within a stated time either to complete specified repairs or improvements or to demolish and remove the building or portion thereof.

15.3.1 The Authority may direct in writing that the building which in his opinion is dangerous, or has no provision for exit if caught fire, shall be vacated immediately or within the period specified for the purpose; provided that the Authority concerned shall keep a record of the reasons for such action with him.

If any person does not comply with the orders of vacating a building, the Authority may direct the police to remove the person from the building and the police shall comply with the orders.

15.4 Disregard of Notice

In case the owner or occupier fails, neglects, or refuses to comply with the notice to repair or to demolish the said building or portion thereof, the Authority shall cause the danger to be removed whether by demolition or repair of the building or portion thereof or otherwise.

15.5 Cases of Emergency

In case of emergency, which, in the opinion of the Authority involves imminent danger to human life or health, the decision of the Authority shall be final. The Authority shall forthwith or with such notice as may be possible promptly cause such building or portion thereof to be rendered safe by retrofitting/strengthening to the same degree of safety or removed. For this purpose, the Authority may at once enter such structure or land on which it stands, or abutting land or structure, with such assistance and at such cost as may be deemed necessary. The Authority may also get the adjacent structures vacated and protect the public by an appropriate fence or such other means as may be necessary.

15.6 Costs

Costs incurred under **15.4** and **15.5** shall be charged to the owner of the premises involved. Such costs shall be charged on the premises in respect of which or for the benefit of which the same have been incurred and shall be recoverable as provided under the laws (*see* Note).

NOTE — The costs may be in the form of arrears of taxes.

16 DEMOLITION OF BUILDING

Before a building is demolished, the owner shall notify all utilities having service connections within the building, such as water, electric, gas, sewer and other connections. A permit to demolish a building shall not be issued until a release is obtained from the utilities stating that their respective service connections and appurtenant equipment, such as, meters and regulators have been removed or sealed and plugged in a safe manner.

17 VALIDITY

17.1 Partial Invalidity

In the event any part or provision of the Code is held to be illegal or void, this shall not have the effect of making void or illegal any of the other parts or provisions thereof, which may or shall be determined to be legal, and it shall be presumed that the Code would have been passed without such illegal or invalid parts or provisions.

17.2 Segregation of Invalid Provisions

Any invalid part of the Code shall be segregated from the remainder of the Code by the court holding such part invalid, and the remainder shall remain effective.

17.3 Decisions Involving Existing Buildings

The invalidity of any provision in any clause of the Code as applied to existing buildings and structures shall not be held to effect the validity of such section in its application to buildings hereafter erected.

18 ARCHITECTURAL CONTROL

18.1 Compliance with the provisions of the Code is adequate for normal buildings. But for major public building complexes or buildings coming up in an important area near historic/monumental buildings and areas of heritage, the aesthetics of the whole scheme may also have to be examined, *vis-a-vis* existing structures. In addition, any development which may mar the general characteristics and environment of historical, architectural or other monuments should also be subject to the provisions of this clause. This clause is intended to cover very few structures to come up in the vicinity of other declared/historically important structures, and the scrutiny shall be limited to the external architectural features only so as to ensure an aesthetic continuance of the existing structures with the new. The scrutiny shall not deal with the routine building plan scrutiny from other requirements of

Code from the point of view of structural safety and functional requirements.

18.2 An Urban Arts Commission shall be established at the city/state level on issues related to urban aesthetics, through a statute. This statutory authority/commission established by an Act of State Legislative Assembly, shall accord approval to all major buildings/important development projects having bearing on the urban aesthetics, depending upon the importance of the area with respect to natural or built heritage or projects on plot areas above 1 hectare and located in specifically identified areas. The Urban Arts Commission shall act as guardian of urban architecture; mainly with regard to building form and envelope, the relationship between the building, and the ambient environment *vis-a-vis* other dependants should be seen in depth.

18.3 The Commission may work in the following manner:

- a) The Commission may select only the important buildings as in **18.1** and examine the same. The person responsible for the schemes, say an architect or an engineer, may examine either alone or with the owner. A study of the plans, elevations, models, etc, should be made. The architect/engineer should explain in general terms the purposes which the building is to serve and the main conditions which have influenced him in preparing the design.
- b) The Commission after full discussion, may communicate their decision in writing to the parties concerned. The Commission may recommend a change in the whole scheme or suggest modifications in the existing scheme, if so required.

18.4 The Urban Arts Commission should also be charged with advising the city government, on schemes which will beautify the city and add to its cultural vitality.

ANNEX A

(Foreword and Clauses 2.17, 6.5, 6.6, 9.1.3, 12.2.8, 12.3 and 12.9)

GUIDE FOR THE QUALIFICATIONS AND COMPETENCE OF PROFESSIONALS

A-1 ESSENTIAL REQUIREMENTS

A-1.1 Every building/development work for which permission is sought under the Code shall be planned, designed and supervised by registered professionals. The registered professionals for carrying out the various activities shall be: (a) architect, (b) engineer, (c) structural engineer, (d) supervisor, (e) town planner, (f) landscape architect, (g) urban designer, and (h) utility service engineer. Requirements of registration for various professionals by the Authority or by the body governing such profession and constituted under a statute, as applicable to practice within the local body's jurisdiction, are given in **A-2.1** to **A-2.5**. The competence of such registered personnel to carry out various activities is also indicated in **A-2.1.1** to **A-2.5.1**.

A-2 REQUIREMENTS FOR REGISTRATION AND COMPETENCE OF PROFESSIONALS

A-2.1 Architect

The minimum qualifications for an architect shall be the qualifications as provided for in the *Architects Act, 1972* for registration with the Council of Architecture.

A-2.1.1 Competence

The registered architect shall be competent to carry out the work related to the building/development permit as given below:

- a) All plans and information connected with building permit except engineering services of multistoreyed/special buildings given in **12.2.5.1**.
- b) Issuing certificate of supervision and completion of all buildings pertaining to architectural aspects.
- c) Preparation of sub-division/layout plans and related information connected with development permit of area up to 1 hectare for metro-cities and 2 hectare for other places.
- d) Issuing certificate of supervision for development of land of area up to 1 hectare for metro-cities and 2 hectare for other places.

A-2.2 Engineer

The minimum qualifications for an engineer shall be graduate in civil engineering/architectural engineering of recognized Indian or foreign university, or the Member of Civil Engineering Division/Architectural

Engineering Division of the Institution of Engineers (India) or the statutory body governing such profession, as and when established.

A-2.2.1 Competence

The registered engineer shall be competent to carry out the work related to the building/development permit as given below:

- a) All plans and information connected with building permit;
- b) Structural details and calculations of buildings on plot up to 500 m² and up to 5 storeys or 16 m in height;
- c) Issuing certificate of supervision and completion for all buildings;
- d) Preparation of all service plans and related information connected with development permit; and
- e) Issuing certificate of supervision for development of land for all area.

A-2.3 Structural Engineer

The minimum qualifications for a structural engineer shall be graduate in civil engineering of recognized Indian or foreign university, or Corporate Member of Civil Engineering Division of Institution of Engineers (India), and with minimum 3 years experience in structural engineering practice with designing and field work.

NOTE — The 3 years experience shall be relaxed to 2 years in the case of post-graduate degree of recognized Indian or foreign university in the branch of structural engineering. In case of doctorate in structural engineering, the experience required would be one year.

A-2.3.1 Competence

The registered structural engineer shall be competent to prepare the structural design, calculations and details for all buildings and supervision.

A-2.3.1.1 In case of buildings having special structural features, as decided by the Authority, which are within the horizontal areas and vertical limits specified in **A-2.2.1(b)** and **A-2.4.1(a)** shall be designed only by structural engineers.

A-2.4 Supervisor

The minimum qualifications for a supervisor shall be diploma in civil engineering or architectural assistantship, or the qualification in architecture or

engineering equivalent to the minimum qualification prescribed for recruitment to non-gazetted service by the Government of India plus 5 years experience in building design, construction and supervision.

A-2.4.1 Competence

The registered supervisor shall be competent to carryout the work related to the building permit as given below:

- a) All plans and related information connected with building permit for residential buildings on plot up to 100 m² and up to two storeys or 7.5 m in height; and
- b) Issuing certificate of supervision for buildings as per (a).

A-2.5 Town Planner

The minimum qualification for a town planner shall be the Associate Membership of the Institute of Town Planners or graduate or post-graduate degree in town and country planning.

A-2.5.1 Competence

The registered town planner shall be competent to carryout the work related to the development permit as given below:

- a) Preparation of plans for land sub-division/ layout and related information connected with development permit for all areas.
- b) Issuing of certificate of supervision for development of land of all areas.

NOTE — However, for land layouts for development permit above 5 hectare in area, landscape architect shall also be associated, and for land development infrastructural services for roads, water supplies, sewerage/drainage, electrification, etc, the registered engineers for utility services shall be associated.

A-2.6 Landscape Architect

The minimum qualification for a landscape architect shall be the bachelor or master's degree in landscape architecture or equivalent from recognized Indian or foreign university.

A-2.6.1 Competence

The registered landscape architect shall be competent to carryout the work related to landscape design for

building/development permit for land areas 5 hectares and above. In case of metro-cities, this limit of land area shall be 2 hectares and above.

NOTE — For smaller areas below the limits indicated above, association of landscape architect may also be considered from the point of view of desired landscape development.

A-2.7 Urban Designer

The minimum qualification for an urban designer shall be the master's degree in urban design or equivalent from recognized Indian or foreign university.

A-2.7.1 Competence

The registered urban designer shall be competent to carryout the work related to the building permit for urban design for land areas more than 5 hectares and campus area more than 2 hectares. He/She shall also be competent to carryout the work of urban renewal for all areas.

NOTE — For smaller areas below the limits indicated above, association of urban designer may be considered from the point of view of desired urban design.

A-2.8 Engineers for Utility Services

For buildings identified in 12.2.5.1, the work of building and plumbing services shall be executed under the planning, design and supervision of competent personnel. The qualification for registered mechanical engineer (including HVAC), electrical engineer and plumbing engineers for carrying out the work of Air-conditioning, Heating and Mechanical Ventilation, Electrical Installations, Lifts and Escalators and Water Supply, Drainage, Sanitation and Gas Supply installations respectively shall be as given in Part 8 'Building Services' and Part 9 'Plumbing Services' or as decided by the Authority taking into account practices of the National professional bodies dealing with the specialist engineering services.

A-3 BUILDER/CONSTRUCTOR ENTITY

The minimum qualification and competence for the builder/constructor entity for various categories of building and infrastructural development shall be as decided by the Authority to ensure compliance of quality, safety and construction practices as required under the Code.

ANNEX B

(Clause 12.1)

FORM FOR FIRST APPLICATION TO DEVELOP, ERECT, RE-ERECT OR TO MAKE ALTERATION IN ANY PLACE IN A BUILDING

To

.....
.....
.....

Sir,

I hereby give notice that I intend to develop, erect, re-erect or to make alteration in the building No..... or to.....on/in Plot No.....in Colony/ Street*MOHALLA/BAZAR/Road*.....Cityand in accordance with the building code ofPart II, Clausesand I forward herewith the following plans and specifications in triplicate duly signed by me and the Architect/Engineer/Structural Engineer/Supervisor/Town Planner/Landscape Architect/Urban Designer¹⁾, Registration No. who will supervise its erection.

(Name in block letters)

1. Key plan
2. Site plans
3. Sub-division/layout plan
4. Building plans
5. Services plans
6. Specifications, general and detailed²⁾
7. Title of ownership of land/building
8. Certificates for structural sufficiency and supervision

I request that the development/construction may be approved and permission accorded to me to execute the work.

Signature of Owner.....

Name of the Owner

(in block letters)

Address of Owner

.....
.....
.....
.....

Date:

¹⁾ Strike out whichever is not applicable.

²⁾ A format may be prepared by the Authority for direct use.

ANNEX C
(Clause 12.2.8)

FORM FOR CERTIFICATE FOR STRUCTURAL DESIGN SUFFICIENCY

With respect to the building work of erection, re-erection or for making alteration in the building No.....or to.....on/in Plot No.Colony/ Street.....*MOHALLA/BAZAR/Road*City....., we certify that the structural plans and details of the building submitted for approval satisfy the structural safety requirements for all situations including natural disasters, as applicable, as stipulated under Part 6 Structural Design of the National Building Code of India and other relevant Codes; and the information given therein is factually correct to the best of our knowledge and understanding.

Signature of owner with date	Signature of the Registered Engineer/ Structural Engineer with date and registration No.
Name:
Address:

ANNEX D
(Clause 12.2.9)

FORM FOR SUPERVISION

I hereby certify that the development, erection, re-erection or material alteration in/of building No..... or theon/in Plot No.....in Colony/ Street*MOHALLA/BAZAR/Road*..... City..... shall be carried out under my supervision and I certify that all the materials (type and grade) and the workmanship of the work shall be generally in accordance with the general and detailed specifications submitted along with, and that the work shall be carried out according to the sanctioned plans.

Signature of Architect/Engineer/Structural Engineer/Supervisor/Town Planner/Landscape Architect/Urban Designer¹⁾

Name of Architect/Engineer/Structural Engineer/Supervisor/Town Planner/Landscape Architect/Urban Designer¹⁾

(in block letters)

Registration No. of Architect/Engineer/Structural Engineer/Supervisor/Town Planner/Landscape Architect/Urban Designer¹⁾

Address of Architect/Engineer/Structural Engineer/Supervisor/Town Planner/Landscape Architect/Urban Designer¹⁾

.....
.....
.....
.....

Date:

¹⁾ Strike out whichever is not applicable.

ANNEX E
(Clause 12.10)

FORM FOR SANCTION OR REFUSAL OF DEVELOPMENT/BUILDING PERMIT

To

.....
.....
.....

Sir,

With reference to your applicationdatedfor grant of permit for the development, erection, re-erection or material alteration in the building No. or to.....on/in Plot No.....in Colony/ Street.....*MOHALLA/BAZAR/Road*.....City.....

I have to inform you that the sanction has been granted/refused by the Authority on the following grounds:

- 1.
- 2.
- 3.
- 4.
- 5.
- 6.

Office Stamp

Signature of the Authority

Office (Communication) No.

Name, Designation and Address
of the Authority.....

Date:

.....
.....

ANNEX F
[Clause 13.2 (d)]

FORM FOR NOTICE FOR COMMENCEMENT

I hereby certify that the development, erection, re-erection or material alteration in/of building No. or the.....on/in Plot No.....in Colony/Street.....*MOHALLA/ BAZAR/Road*.....Citywill be commenced on as per your permission, vide No.....dated.....under the supervision ofRegistered Architect/Engineer/Structural Engineer/Supervisor/Town Planner/Landscape Architect/Urban Designer¹⁾, Registration No.....and in accordance with the plans sanctioned, vide No.....dated.....

Signature of Owner

Name of Owner
(in block letters)

Address of Owner.....

.....
.....

Date:

¹⁾ Strike out whichever is not applicable.

ANNEX G

[Clause 13.2(f)]

FORM FOR CERTIFICATE FOR EXECUTION OF WORK AS PER STRUCTURAL SAFETY REQUIREMENTS

With respect to the building work of erection, re-erection or for making alteration in the building No.....
or toon/in Plot No.....Colony/StreetMOHALLA/
BAZAR/RoadCity....., we certify:

- a) that the building has been constructed according to the sanctioned plan and structural design (one set of drawings as executed enclosed), which incorporates the provisions of structural safety as specified in Part 6 'Structural Design' of the National Building Code of India and other relevant Codes; and
- b) that the construction has been done under our supervision and guidance and adheres to the drawings and specifications submitted and records of supervision have been maintained.

Any subsequent changes from the completion drawings shall be the responsibility of the owner.

Signature of owner
with date

Signature of the
Registered Engineer/
Structural Engineer with
date and registration No.

Name:

Address:

ANNEX H

[Clause 13.2 (f)]

FORM FOR COMPLETION CERTIFICATE

I hereby certify that the development, erection, re-erection or material alteration in/of building No.....
or the on/in Plot No..... in Colony/Street MOHALLA/BAZAR/
Road.....City..... has been supervised by me and has been completed on
..... according to the plans sanctioned, vide No. dated The work
has been completed to my best satisfaction, the workmanship and all the materials (type and grade) have been
used strictly in accordance with general and detailed specifications. No provisions of the Code, no requisitions
made, conditions prescribed or orders issued thereunder have been transgressed in the course of the work. The
land is fit for construction for which it has been developed or re-developed or the building is fit for use for which
it has been erected, re-erected or altered, constructed and enlarged.

I hereby also enclose the plan of the building completed in all aspects.

Signature of Architect/Engineer/Structural Engineer/Supervisor/Town Planner/Landscape Architect/Urban
Designer¹⁾

Name of Architect/Engineer/Structural Engineer/Supervisor/Town Planner/Landscape Architect/Urban
Designer¹⁾

(in block letters)

Registration No. of Architect/Engineer/Structural Engineer/Supervisor/Town Planner/Landscape Architect/Urban
Designer¹⁾

Address of Architect/Engineer/Structural Engineer/Supervisor/Town Planner/Landscape Architect/Urban
Designer¹⁾

Date:

Signature of the Owner

¹⁾ Strike out whichever is not applicable.

ANNEX J

[Clause 13.2(h)]

FORM FOR OCCUPANCY PERMIT

The work of erection, re-erection or alteration in/of building No.....or the.....on/
in Plot No.....in Colony/Street.....*MOHALLA/BAZAR/Road*.....
City.....completed under the supervision of.....Architect/Engineer/Structural
Engineer/Supervisor, Registration No.....has been inspected by me. The building can be permitted/
not permitted for occupation foroccupancy subjected to the following:

- 1.
- 2.
- 3.

One set of completion plans duly certified is returned herewith.

Signature of the Authority

Office Stamp

Date:

NATIONAL BUILDING CODE OF INDIA

PART 3 DEVELOPMENT CONTROL RULES AND GENERAL BUILDING REQUIREMENTS

BUREAU OF INDIAN STANDARDS

CONTENTS

FOREWORD	...	3
1 SCOPE	...	7
2 TERMINOLOGY	...	7
3 LAND USE CLASSIFICATION AND USES PERMITTED	...	12
4 MEANS OF ACCESS	...	13
5 COMMUNITY OPEN SPACES AND AMENITIES	...	15
6 REQUIREMENTS OF PLOTS	...	21
7 CLASSIFICATION OF BUILDINGS	...	22
8 OPEN SPACES (WITHIN A PLOT)	...	23
9 AREA AND HEIGHT LIMITATIONS	...	26
10 OFF-STREET PARKING SPACES	...	28
11 GREENBELTS, LANDSCAPING AND WATER CONSERVATION	...	29
12 REQUIREMENTS OF PARTS OR BUILDINGS	...	29
13 FIRE AND LIFE SAFETY	...	34
14 DESIGN AND CONSTRUCTION	...	34
15 LIGHTING AND VENTILATION	...	34
16 ELECTRICAL AND ALLIED INSTALLATIONS (INCLUDING LIGHTNING PROTECTION OF BUILDINGS)	...	35
17 AIR CONDITIONING, HEATING AND MECHANICAL VENTILATION	...	35
18 ACOUSTICS, SOUND INSULATION AND NOISE CONTROL	...	35
19 HEAT INSULATION	...	35
20 INSTALLATION OF LIFTS AND ESCALATORS	...	35
21 PLUMBING SERVICES AND SOLID WASTE MANAGEMENT	...	35
ANNEX A CIVIL AVIATION REQUIREMENTS FOR CONSTRUCTION IN THE VICINITY OF AN AERODROME	...	36
ANNEX B OFF-STREET PARKING SPACES	...	41
ANNEX C SPECIAL REQUIREMENTS FOR LOW INCOME HOUSING IN URBAN AREAS	...	42
ANNEX D SPECIAL REQUIREMENTS FOR PLANNING OF PUBLIC BUILDINGS MEANT FOR USE OF PHYSICALLY CHALLENGED	...	45
ANNEX E SPECIAL REQUIREMENTS OF CLUSTER PLANNING FOR HOUSING	...	56
ANNEX F SPECIAL REQUIREMENTS FOR LOW INCOME HABITAT PLANNING IN RURAL AREAS	...	57
ANNEX G SPECIAL REQUIREMENTS FOR DEVELOPMENT PLANNING IN HILLY AREAS	...	60
LIST OF STANDARDS	...	63

FOREWORD

This Part covers development control rules, including such aspects as sub-division and layout rules, land use classifications, open spaces, area and height limitations, means of access, and parking spaces; this part also covers the general building requirements, such as the requirements of parts of buildings, provision of lifts, etc.

It is expected that for proper coordination and enforcement of the development control rules and general building requirements, the departments concerned, namely, the town planning department and the building department, will coordinate the total development and building activity at both organizational and technical levels.

Particular attention is invited to Table 3 on floor area ratio (FAR) limitations. It is emphasized that the floor area of a single storey building is limited in absolute terms by the type of construction and occupancy class. Also, the absolute floor areas for different types of construction and different occupancies have a definite ratio among them. The ratios as recommended in the American Iron and Steel Institute publication 1961 'Fire Protection Through Modern Building Codes' have been generally adopted in this Part and Table 3 has been developed on this basis. Table 3 is repeated in Part 4 'Fire and Life Safety' also for convenience of reading.

Limitation of areas and heights of buildings is achieved in this country by specifying it in terms of floor area ratio (FAR) or floor space index (FSI). The significance of the contribution of different types of construction giving different fire resistances has not been taken cognizance of in specifying FAR for different occupancies, in the present development control rules and municipal byelaws of the country. Table 3, therefore, gives the comparative ratios of FAR between types of buildings and occupancy classes and these have been specified mainly from the fire protection aspect of buildings. To arrive at the actual FAR for different buildings coming up in different areas, the Authority should further modify them, by taking into consideration other aspects like density of any area, parking facilities required, the traffic load (road width) and the services available. The heights of buildings shall also be regulated, keeping in view the local fire fighting facilities.

In some state byelaws, the FAR (or FSI) has been expressed in the form of percentage. However, the Committee responsible for preparation of this Code is of the opinion that, it being a ratio should be expressed only in the form of a ratio, as done in this Part.

It is particularly to be borne in mind by the Authority that the ratios are definitive and it can assess the particular FAR for a type of construction and for an occupancy and establish a new table, but retaining the comparative ratios as given in Table 3.

Keeping in view the enormous problems faced by the country with regard to the ever increasing squatter settlements/pavement dwellers in urban areas (cities of all sizes), it is imperative that all the urban local bodies sooner or later evolve schemes for their rehabilitation. The resources are meagre and the problems are enormous. There has been a tendency on the part of a number of development agencies/local bodies to link space norms with affordability. Affordability is an important criterion but at the same time a public agency cannot ignore the basic minimum needs of the family to be housed (including the mental, physical and social health of the marginalized groups, which is linked with shelter). The local bodies shall have to evolve appropriate policies for their integration with the broad urban society and generate/allocate resources and more importantly adopt a planning process, which are people friendly. The Government of India has also formulated the National Slum Policy to this effect. Therefore, keeping in view the needs of low income housing, to cater to Economically Weaker Sections of Society (EWS) and Low Income Group (LIG), the requirements on planning, design of layout/shelter have been rationalized and the same are provided in this Part. This will contribute significantly in the massive housing programmes undertaken for the low income sector. This information is based on the provisions of IS 8888 (Part 1) : 1993 'Guide for requirements of low income housing: Part 1 Urban areas (first revision)'.

Further, city development process would need a dynamic approach to take care of urban renewal and also development needs in dense core areas of the cities. Innovative approaches in planning and design with participating models of public private-people's partnership become necessary to solve the emerging development needs. With

this in view, many city development agencies have evolved innovative planning and development tools like transferable development rights (TDR) where the developer would receive a portion of the development rights in a new location, keeping in view the constraints in the existing land area and the development potential. Such development rights can be transferred into outskirts or new developed areas where land availability is assured. This would encourage the professionals and developers to participate in urban renewal and at the same time ensure that the developments in both the inner core areas and new areas take place in an orderly and efficient manner. The TDR concept should be increasingly encouraged by the authority dealing with urban renewal, re-development projects including housing and re-development projects for slum including dwellers.

Urbanization in India is taking place at a rapid pace. With 5 million population in cities at the time of independence, it has already crossed 28 million (2001 census). It is likely to be 50 million by 2021. The number of cities and towns have been expanding and there are 5 161 cities and towns of various sizes. In the Indian practice cities over 50 lakhs population have been identified as mega-cities (6 in number) and cities over 10 lakhs (29 in number) population as metro-cities. These 35 cities above 10 lakhs population is likely to be above 70 by 2021. The other cities are either small or medium towns or cities with different population limits. Urbanization in each of above cities and towns (mega-cities, metro-cities, small and medium towns and cities) will be different in nature and the development challenges are also different keeping in view the extent of urbanization, industrialization, commercialization and the nature of transportation needs. Therefore, the Code provisions should be appropriately utilized depending upon the need of hierarchy of cities for which the administrative and technical requirements have been covered in the Code for various facets of the activity.

The first version of this Part was prepared in 1970. As a result of incorporation of this Part in the revised development control rules and building byelaws of some municipal corporations and municipalities, some useful suggestions had emerged. First revision of this part was brought out in 1983, where these suggestions were incorporated to the extent possible. The major modifications incorporated in the first revision included:

- a) Addition of development control rules giving guidance on means of access, community spaces and other aspects required for planning layouts.
- b) Addition of provisions regarding plot sizes and frontage for different types of buildings, such as detached, semi-detached, row type and special housing schemes.
- c) Requirements of open spaces for other occupancies, such as educational, institutional, assembly, industrial buildings, etc, were included.
- d) Provisions relating to interior open space were elaborated, including requirements for ventilation shaft.
- e) Requirements of open spaces for group housing development were covered.
- f) Requirements of off-street parking spaces were covered.
- g) Requirements for greenbelts and landscaping including norms for plantations of shrubs and trees were covered.
- h) Requirements of certain parts of buildings, such as loft, store room, garage, basement, chimney, parapet, cabin, boundary wall, wells, septic tanks, office-cum-letter box room, meter room were included.
- j) Special requirements of low income housing were covered.

The term Development Control Rules used in this Part encompasses the related aspects comprehensively with a view to promoting orderly development of an area.

This second revision is being brought out to incorporate the modifications found necessary in light of the experience gained with the use of this Part. Significant modifications incorporated in this revision include:

- a) Terminology given in this Part has been made exhaustive by incorporating definitions of additional terms used, such as, access, chimney, to erect, etc, and number of terms pertaining to cluster planning for housing.
- b) Detailed planning norms/open spaces for various amenities such as educational facilities, health care facilities, socio-cultural facilities, distribution services, police, civil defence and home guards, and fire services have been included.
- c) Off-street parking requirements have now been also included for cities with population (i) between 1 000 000 and 5 000 000, and (ii) above 5 000 000 (*see Annex B*).
- d) Special requirements for low income housing given in the earlier version have been modified and updated (*see Annex C*) based on IS 8888 (Part 1) : 1993 'Guide for requirements of low income housing:

Part 1 Urban area (*first revision*)'. In these revised provisions, single room dwelling has been discouraged, guidelines for water seal latrine have also been incorporated, and cluster planning approach has been recommended.

- e) Requirements for cluster planning for housing have been added (*see* Annex E), which are based on the guidelines given in IS 13727 : 1993 'Guide for requirements of cluster planning for housing'.
- f) Special requirements for low income housing for rural habitat planning has been added (*see* Annex F).
- g) Special requirements for development planning in hilly areas has been added (*see* Annex G).
- h) The requirements for buildings and facilities for the physically challenged have been revised, with listing of additional categories of physically challenged; modifications in requirements of ramps, stairs, doors, handrails and controls; and incorporation of additional requirements regarding windows.
- j) Also, the opportunity has been utilized to update the reference to Indian Standards.

NATIONAL BUILDING CODE OF INDIA

PART 3 DEVELOPMENT CONTROL RULES AND GENERAL BUILDING REQUIREMENTS

1 SCOPE

This Part deals with the development control rules and general building requirements to ensure health and safety of the public.

2 TERMINOLOGY

2.0 For the purpose of this part, the following definitions shall apply:

2.1 Access — A clear approach to a plot or a building.

2.2 Accessory Use — Any use of the premises subordinate to the principal use and customarily incidental to the principal use.

2.3 Alteration — A change from one occupancy to another, or a structural change, such as an addition to the area or height, or the removal of part of a building, or any change to the structure, such as the construction of, cutting into or removal of any wall, partition, column, beam, joist, floor or other support, or a change to or closing of any required means of ingress or egress or a change to the fixtures or equipment.

2.4 Approved — Approved by the Authority having jurisdiction.

2.5 Authority Having Jurisdiction — The Authority which has been created by a statute and which for the purpose of administering the Code/Part may authorize a committee or an official to act on its behalf; hereinafter called the 'Authority'.

2.6 Back-to-Back Cluster — Clusters when joined back to back and/or on sides (*see Fig. 1*).

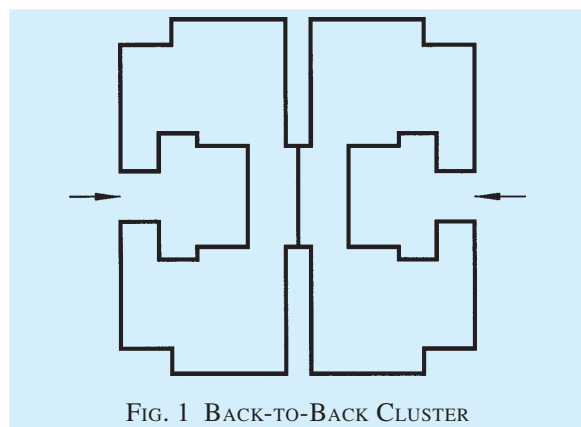

FIG. 1 BACK-TO-BACK CLUSTER

2.7 Balcony — A horizontal projection, with a handrail or balustrade or a parapet, to serve as passage or sitting out place.

2.8 Basement or Cellar — The lower storey of a building below or partly below ground level.

2.9 Building — Any structure for whatsoever purpose and of whatsoever materials constructed and every part thereof whether used as human habitation or not and includes foundation, plinth, walls, floors, roofs, chimneys, plumbing and building services, fixed platforms, *VERANDAH*, balcony, cornice or projection, part of a building or anything affixed thereto or any wall enclosing or intended to enclose any land or space and signs and outdoor display structures. Tents, *SHAMIANAHs*, tarpaulin shelters, etc, erected for temporary and ceremonial occasions with the permission of the Authority shall not be considered as building.

2.10 Building, Height of — The vertical distance measured in the case of flat roofs, from the average level of the ground around and contiguous to the building or as decided by the Authority to the terrace of last livable floor of the building adjacent to the external walls; and in the case of pitched roofs, up to the point where the external surface of the outer wall intersects the finished surface of the sloping roof; and in the case of gables facing the road, the mid-point between the eaves level and the ridge. Architectural features serving no other function except that of decoration shall be excluded for the purpose of measuring heights.

2.11 Building Envelope — The horizontal spatial limits up to which a building may be permitted to be constructed on a plot.

2.12 Building Line — The line up to which the plinth of a building adjoining a street or an extension of a street or on a future street may lawfully extend. It includes the lines prescribed, if any, in any scheme. The building line may change from time-to-time as decided by the Authority.

2.13 Cabin — A non-residential enclosure constructed of non-load bearing partition.

2.14 Canopy — A projection over any entrance.

2.15 Carpet Area — The covered area of the usable rooms at any floor level (excluding the area of the wall).

2.16 CHHAJJA — A sloping or horizontal structural overhang usually provided over openings on external walls to provide protection from sun and rain.

2.17 Chimney — An upright shaft containing one or more flues provided for the conveyance to the outer air of any product of combustion resulting from the operation of heat producing appliance or equipment employing solid, liquid or gaseous fuel.

2.18 Chowk or Courtyard — A space permanently

open to the sky, enclosed fully or partially by building and may be at ground level or any other level within or adjacent to a building.

2.19 Chowk, Inner — A chowk enclosed on all sides.

2.20 Chowk, Outer — A chowk one of whose sides is not enclosed.

2.21 Closed Clusters — Clusters with only one common entry into cluster open space (see Fig. 2).

2.22 Cluster — Plots or dwelling units or housing grouped around an open space (see Fig. 3).

Ideally housing cluster should not be very large. In ground and one storeyed structures not more than 20 houses should be grouped in a cluster. Clusters with more dwelling units will create problems in identity, encroachments and of maintenance.

2.23 Cluster Court Town House — A dwelling in a cluster plot having 100 percent or nearly 100 percent ground coverage with vertical expansion, generally limited to one floor only and meant for self use.

2.24 Cluster Plot — Plot in a cluster.

2.25 Cooking Alcove — A cooking space having

direct access from the main room without any inter-communicating door.

2.26 Covered Area — Ground area covered by the building immediately above the plinth level. The area covered by the following in the open spaces is excluded from covered area (see Table 3):

- a) Garden, rockery, well and well structures, plant nursery, waterpool, swimming pool (if uncovered), platform round a tree, tank, fountain, bench, *CHABUTRA* with open top and unenclosed on sides by walls and the like;
- b) Drainage culvert, conduit, catch-pit, gully pit, chamber, gutter and the like;
- c) Compound wall, gate, unstoreyed porch and portico, canopy, slide, swing, uncovered staircase, ramps areas covered by *CHHAJJA* and the like; and
- d) Watchmen's booth, pumphouse, garbage shaft, electric cabin or sub-stations, and such other utility structures meant for the services of the building under consideration.

NOTE — For the purpose of this Part, covered area equals the plot area minus the area due for open spaces.

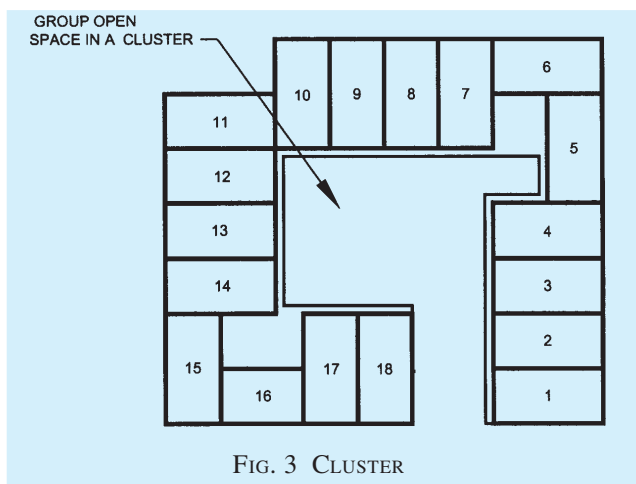
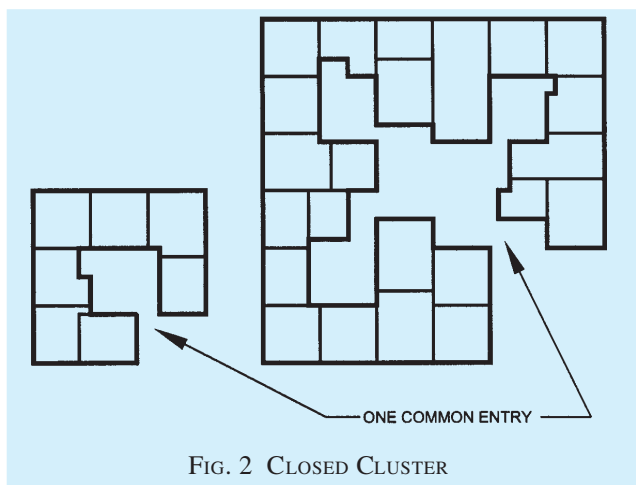

2.27 'Cul-de-Sac' Cluster

Plots/dwelling units when located along a pedestrianised or vehicular 'cul-de-sac' road (see Fig. 4).

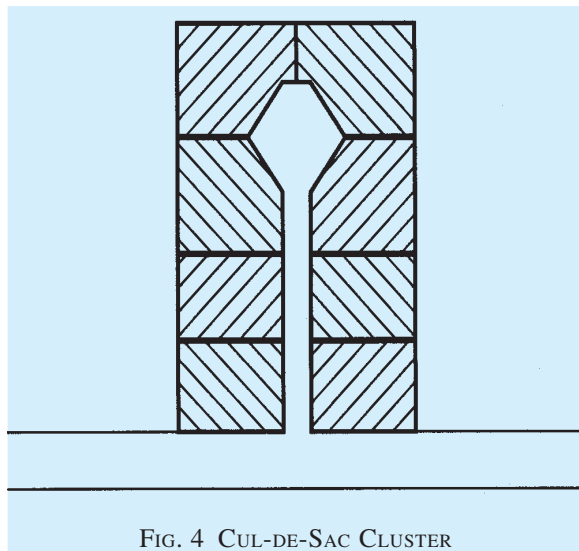

FIG. 4 CUL-DE-SAC CLUSTER

2.28 Density — The residential density expressed in terms of the number of dwelling units per hectare.

NOTE — Where such densities are expressed exclusive of community facilities and provision of open spaces and major roads (excluding incidental open spaces), these will be net residential densities. Where these densities are expressed taking into consideration the required open space provision and community facilities and major roads, these would be gross residential densities at neighbourhood level, sector level or town level, as the case may be. The provision of open spaces and community facilities will depend on the size of the residential community.

Incidental open spaces are mainly open spaces required to be left around and in between two buildings to provide lighting and ventilation.

2.29 Detached Building — A building detached on all sides.

2.30 Development — 'Development' with grammatical variations means the carrying out of building, engineering, mining or other operations, in, or over, or under land or water, on the making of any material change, in any building or land, or in the use of any building, land, and includes re-development and layout and subdivision of any land and 'to develop' shall be construed accordingly.

2.31 Drain — A conduit, channel or pipe for the carriage of storm water, sewage, waste water or other water borne wastes in a building drainage system.

2.32 Drainage — The removal of any liquid by a system constructed for the purpose.

2.33 Dwelling Unit/Tenement — An independent housing unit with separate facilities for living, cooking and sanitary requirements.

2.34 Escalator — A power driven, inclined, continuous stairway used for raising or lowering passengers.

2.35 Exit — A passage, channel or means of egress from any building, storey or floor area to a street or other open space of safety.

2.36 External Faces of Cluster — Building edges facing the cluster open spaces.

2.37 Fire Separation — The distance in metres measured from the external wall of the building concerned to the external wall of any other building on the site, or from other site, or from the opposite side of a street or other public space for the purpose of preventing the spread of fire.

2.38 Floor — The lower surface in a storey on which one normally walks in a building. The general term 'floor' unless specifically mentioned otherwise shall not refer to a 'mezzanine floor'.

2.39 Floor Area Ratio (FAR) — The quotient obtained by dividing the total covered area (plinth area) on all floors by the area of the plot:

$$\text{FAR} = \frac{\text{Total covered area of the floors}}{\text{Plot area}}$$

2.40 Gallery — An intermediate floor or platform projecting from a wall of an auditorium or a hall providing extra floor area, additional seating accommodation, etc. It shall also include the structures provided for seating in stadia.

2.41 Garage, Private — A building or a portion thereof designed and used for parking of private owned motor driven or other vehicles.

2.42 Garage, Public — A building or portion thereof, other than a private garage, designed or used for repairing, servicing, hiring, selling or storing or parking motor driven or other vehicles.

2.43 Group Housing — Housing for more than one dwelling unit, where land is owned jointly (as in the case of co-operative societies or the public agencies, such as local authorities or housing boards, etc) and the construction is undertaken by one Agency.

2.44 Group Open Space — Open space within a cluster.

Group open space is neither public open space nor private open space. Each dwelling unit around the cluster open space have a share and right of use in it. The responsibility for maintenance of the same is to be collectively shared by all the dwelling units around.

2.45 Habitable Room — A room occupied or designed for occupancy by one or more persons for study, living, sleeping, eating, kitchen if it is used as a

living room, but not including bathrooms, water-closet compartments, laundries, serving and store pantries, corridors, cellars, attics, and spaces that are not used frequently or during extended periods.

2.46 Independent Cluster — Clusters surrounded from all sides by vehicular access roads and/or pedestrian paths (*see* Fig. 5).

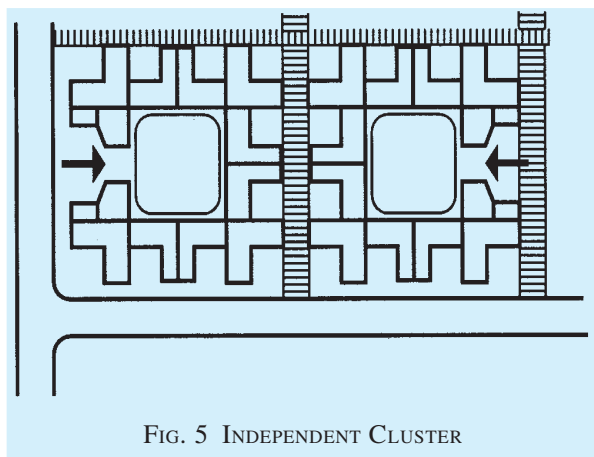

FIG. 5 INDEPENDENT CLUSTER

2.47 Interlocking Cluster — Clusters when joined at back and on sides with at least one side of a cluster common and having some dwelling units opening onto or having access from the adjacent clusters.

Dwelling units in such clusters should have at least two sides open to external open space. Houses in an interlocking cluster can have access, ventilation and light from the adjacent cluster and should also cater for future growth (*see* Fig. 6).

2.48 Internal Faces of Cluster — Building edges facing the adjacent cluster open space (as in case of interlocking cluster) of the surrounding pedestrian paths or vehicular access roads.

2.49 Ledge or TAND — A shelf-like projection, supported in any manner whatsoever, except by means of vertical supports within a room itself but not having projection wider than 1 m.

2.50 Lift — An appliance designed to transport persons or materials between two or more levels in a vertical or substantially vertical direction by means of a guided car or platform. The word ‘elevator’ is also synonymously used for ‘lift’.

2.51 Loft — A structure providing intermediate storage space in between two floors with a maximum height of 1.5 m, without having a permanent access.

2.52 Mezzanine Floor — An intermediate floor between two floors of any storey forming an integral part of floor below.

2.53 Occupancy or Use Group — The principal occupancy for which a building or a part of a building is used or intended to be used; for the purposes of classification of a building according to occupancy; an occupancy shall be deemed to include subsidiary occupancies which are contingent upon it.

2.54 Occupancy, Mixed — The occupancy, where more than one occupancy are present in different portions of the building.

2.55 Open Clusters — Cluster where cluster open spaces are linked to form a continuous open space (*see* Fig. 7).

2.56 Open Space — An area, forming an integral part of the plot, left open to the sky.

NOTE — The open space shall be the minimum distance measured between the front, rear and side of the building and the respective plot boundaries.

2.57 Open Space, Front — An open space across the front of a plot between the building line and front boundary of the plot.

2.58 Open Space, Rear — An open space across the rear of a plot between the rear of the building and the rear boundary of the plot.

2.59 Open Space, Side — An open space across the side of the plot between the side of the building and the side boundary of the plot.

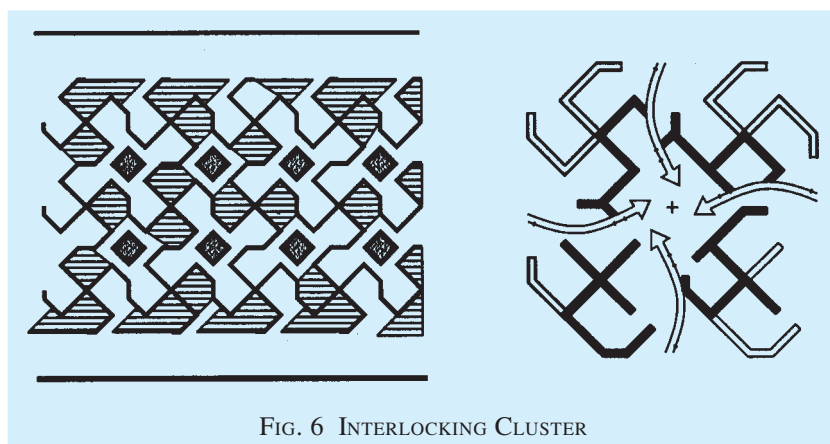

FIG. 6 INTERLOCKING CLUSTER

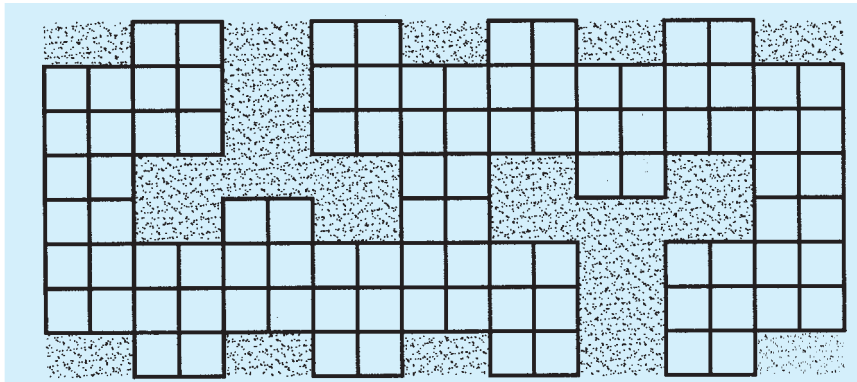

FIG. 7 OPEN CLUSTER

2.60 Owner — Person or body having a legal interest in land and/or building thereon. This includes free holders, leaseholders or those holding a sub-lease which both bestows a legal right to occupation and gives rise to liabilities in respect of safety or building condition.

In case of lease or sub-lease holders, as far as ownership with respect to the structure is concerned, the structure of a flat or structure on a plot belongs to the allottee/lessee till the allotment/lease subsists.

2.61 Parapet — A low wall or railing built along the edge of a roof or floor.

2.62 Parking Space — An area enclosed or unenclosed, covered or open, sufficient in size to park vehicles, together with a drive-way connecting the parking space with a street or alley and permitting ingress and egress of the vehicles.

2.63 Partition — An interior non-load bearing barrier, one storey or part-storey in height.

2.64 Plinth — The portion of a structure between the surface of the surrounding ground and surface of the floor, immediately above the ground.

2.65 Plinth Area — The built up covered area measured at the floor level of the basement or of any storey.

2.66 Porch — A covered structure supported on pillars or otherwise for the purpose of pedestrian or vehicular approach to a building.

2.67 Road — See 2.82.

2.68 Road Line — See 2.84.

2.69 Room Height — The vertical distance measured from the finished floor surface to the finished ceiling surface. Where a finished ceiling is not provided, the underside of the joists or beams or tie beams shall determine the upper point of measurement.

2.70 Row Housing/Row Type Building — A row of buildings, with only front, rear and interior open spaces where applicable.

2.71 Semi-Detached Building — A building detached on three sides.

2.72 Service Road/Lane — A road/lane provided adjacent to a plot(s) for access or service purposes as the case may be.

2.73 Set-Back Line — A line usually parallel to the plot boundaries and laid down in each case by the Authority, beyond which nothing can be constructed towards the plot boundaries.

2.74 Site (Plot) — A parcel (piece) of land enclosed by definite boundaries.

2.75 Site, Corner — A site at the junctions of and fronting on two or more intersecting streets.

2.76 Site, Depth of — The mean horizontal distance between the front and rear site boundaries.

2.77 Site, Double Frontage — A site, having a frontage on two streets, other than a corner plot.

2.78 Site, Interior or Tandem — A site access to which is by a passage from a street whether such passage forms part of the site or not.

2.79 Staircover (or MUMTY) — A structure with a roof over a staircase and its landing built to enclose only the stairs for the purpose of providing protection from weather and not used for human habitation.

2.80 Storey — The portion of a building included between the surface of any floor and the surface of the floor next above it, or if there be no floor above it, then the space between any floor and the ceiling next above it.

2.81 Storey, Topmost — The uppermost storey in a building whether constructed wholly or partly on the roof.

2.82 Street — Any means of access, namely, highway, street, lane, pathway, alley, stairway, passageway, carriageway, footway, square, place or bridge, whether a thoroughfare or not, over which the public have a right of passage or access or have passed and had access uninterruptedly for a specified period, whether existing or proposed in any scheme, and includes all bunds, channels, ditches, storm-water drains, culverts, sidewalks, traffic islands, roadside trees and hedges, retaining walls, fences, barriers and railings within the street lines.

2.83 Street Level or Grade — The officially established elevation or grade of the central line of the street upon which a plot fronts and if there is no officially established grade, the existing grade of the street at its mid-point.

2.84 Street Line — The line defining the side limits of a street.

2.85 To Abut — To abut on a street boundary such that any portion of the building is on the road boundary.

2.86 To Erect — To erect a building means:

- a) to erect a new building on any site whether previously built upon or not; and
- b) to re-erect any building of which portions above the plinth level have been pull down, burnt or destroyed.

2.87 Tower-like Structures — Structures shall be deemed to be tower-like structures when the height of the tower-like portion is at least twice the height of the broader base at ground level.

2.88 VERANDAH — A covered area with at least one side open to the outside with the exception of 1 m high parapet on the upper floors to be provided on the open side.

2.89 Volume to Plot Area Ratio (VPR) — The ratio of volume of building measured in cubic metres to the area of the plot measured in square metres and expressed in metres.

2.90 Water-Closet (WC) — A water flushed plumbing fixture designed to receive human excrement directly from the user of the fixture. The term is used sometimes to designate the room or compartment in which the fixture is placed.

2.91 Window — An opening to the outside other than a door, which provides all or part of the required natural light or ventilation or both to an interior space.

3 LAND USE CLASSIFICATION AND USES PERMITTED

3.1 Land Use Classification

The land use classification may be as indicated below:

<i>Sl No.</i>	<i>Use Zone (Level 1)</i>	<i>Use Zone (Level 2)</i>
(1)	(2)	(3)
i)	Residential (R)	Primary Residential Zone (R-1) Mixed Residential Zone (R-2) Unplanned/Informal Residential Zone (R-3)
ii)	Commercial (C)	Retail Shopping Zone (C-1) General Business and Commercial District/Centres (C-2) Wholesale, Godowns, Warehousing/Regulated Markets (C-3)
iii)	Manufacturing (M)	Service and Light Industry (M-1) Extensive and Heavy Industry (M-2) Special Industrial Zone Hazardous, Noxious and Chemical (M-3)
iv)	Public and Semi-Public (PS)	Government/Semi-Government/Public Offices (PS-1) Government Land (use determined) (PS-2) Educational and Research (PS-3) Medical and Health (PS-4) Social, Cultural and Religious (PS-5) Utilities and Services (PS-6) Cremation and Burial Grounds (PS-7)
v)	Recreational (P)	Playgrounds/Stadium/Sports Complex (P-1) Parks and Gardens — Public Open Spaces (P-2) Special Recreational Zone — Restricted Open Spaces (P-3) Multi-Open Space (Maidan) (P-4)

<i>Sl No.</i>	<i>Use Zone (Level 1)</i>	<i>Use Zone (Level 2)</i>
(1)	(2)	(3)
vi)	Transportation and Communication (T)	Roads (T-1) Railways (T-2) Airport (T-3) Seaports and Dockyards (T-4) Bus Depots/Truck Terminals and Freight Complexes (T-5) Transmission and Communication (T-6)
vii)	Agriculture and Water Bodies	Agriculture (A-1) Forest (A-2) Poultry and Dairy Farming (A-3) Rural Settlements (A-4) Brick Kiln and Extractive Areas (A-5) Water Bodies (A-6)
viii)	Special Area	Old Built-up (Core) Area (S-1) Heritage and Conservation Areas (S-2) Scenic Value Areas (S-3) Village Settlement (S-4) Other Uses (S-5)

NOTES

- 1 Areas of informal activities may be identified in the above land use categories at Level 2.
- 2 Mixed use zone may be identified at the development plan level, having more than one use zone with mixed activities of such use zones.
- 3 In all, there could be 35 use zones at the development plan level within eight land use categories at the perspective plan level as given in the above table.
- 4 Use premises for different activities could be provided at the project/action plan level or with the approval of the Authority as the case may be.
- 5 Use zone regulations for the use permissibility could be decided by the town planner depending upon the requirement/feasibility.

3.2 The various building uses and occupancies (*see 7*) permitted on the various zones shall be as given in the Master Plan.

3.3 Uses to be in Conformity with the Zone

Where the use of buildings or premises is not specifically designated on the Development Plan or in the absence of Development Plan, shall be in conformity with the zone in which they fall.

3.4 Uses as Specifically Designated on Development Plan

Where the use of a site is specifically designated on the Development Plan, it shall be used only for the purpose so designated.

3.5 Non-conforming Uses

No plot shall be put to any use, occupancy or premises other than the uses identified in **3.1**, except with the prior approval of the Authority.

3.6 Fire Safety

Buildings shall be so planned, designed and constructed as to ensure fire safety and this shall be done as per Part 4 ‘Fire and Life Safety’.

4 MEANS OF ACCESS

4.1 Every building/plot shall abut on a public/private means of access like streets/roads duly formed.

4.2 Every person who erects a building shall not at any time erect or cause or permit to erect any building which in any way encroaches upon or diminishes the area set apart as means of access required in the Code. No buildings shall be erected so as to deprive any other building of the means of access.

4.3 Width of Means of Access

The residential plots shall abut on a public means of access like street/road. Plots which do not abut on a street/road shall abut/front on a means of access, the width and other requirements of which shall be as given in Table 1.

Table 1 Width and Length of Means of Access
(Clause 4.3)

Sl No.	Width of Means of Access m	Length of Means of Access m
(1)	(2)	(3)
i)	6.0	75
ii)	7.5	150
iii)	9.0	250
iv)	12.0	400
v)	18.0	1 000
vi)	24.0	above 1 000

NOTE — If the development is only on one side of the means of access, the prescribed widths may be reduced by 1 m in each case.

In no case, development on plots shall be permitted unless it is accessible by a public street of width not less than 6 m.

4.3.1 Other Buildings

For all industrial buildings, theatres, cinema houses, assembly halls, stadia, educational buildings, markets, other buildings which attract large crowd, the means of access shall not be less than the following:

Width of Means of Access m	Length of Means of Access m
12.0	200
15.0	400
18.0	600
24.0	above 600

Further, in no case shall the means of access be lesser in width than the internal accessways in layouts and subdivision.

4.3.2 Pathways

The approach to the buildings from road/street/internal means of access shall be through paved pathway of width not less than 1.5 m, provided its length is not more than 30 m.

4.3.2.1 In the case of special housing schemes for low income group and economically weaker section of society developed up to two storeyed row/cluster housing scheme, the pedestrian pathway width shall be 3 m subject to provisions of 9.4.1(a). The pedestrian pathway shall not serve more than 8 plots on each side of the pathway; the length of the pathway shall be not more than 50 m.

4.3.3 The length of the main means of access shall be determined by the distance from the farthest plot (building) to the public street. The length of the subsidiary accessway shall be measured from the point of its origin to the next wider road on which it meets.

4.3.4 In the interest of general development of an area, the Authority may require the means of access to be of larger width than that required under 4.3 and 4.3.1.

4.3.5 In existing built-up areas in the case of plots facing street/means of access less than 4.5 m in width, the plot boundary shall be shifted to be away by 2.25 m from the central line of the street/means of accessway to give rise to a new street/means of accessway of 4.5 m width.

4.4 The means of access shall be levelled, metalled, flagged, paved, sewered, drained, channelled, lighted, laid with water supply line and provided with trees for shade to the satisfaction of the Authority free of encroachment by any structure or fixture so as not to reduce its width below the minimum required under 4.3 and shall be maintained in a condition to the satisfaction of the Authority.

4.4.1 If any private street or any other means of access to a building is not levelled, metalled, flagged or paved, sewered, drained, channelled, lighted or laid with water supply line or provided with trees for shade to the satisfaction of the Authority, who may, with the sanction of the Authority, by written notice require the owner or owners of the several premises fronting or adjoining the said street or other means of access or abutting thereon or to which access is obtained through such street or other means of access or which shall benefit by works executed, to carry out any or more of the aforesaid requirements in such manner as he shall direct.

4.4.2 If any structure or fixture is set upon a means of access so as to reduce its width below the minimum required, the Authority may remove the same further and recover the expenses so incurred from the owner.

4.5 Access from Highways/Important Roads

No premises other than highway amenities like petrol pumps, motels, etc, shall have an access direct from highways and such other roads not less than 52 m in width, which the Authority with the approval of the Highway Authority shall specify from time-to-time. The Authority shall maintain a register of such roads which shall be open to public inspection at all times during office hours. The portion of such roads on which direct access may be permitted shall be as identified in the Development Plan. However, in the case of existing development on highways/other roads referred to above, the operation of this clause shall be exempted. These provisions shall, however, be subject to the provisions of the relevant State Highway Act, and National Highway Act.

4.6 For high rise buildings and buildings other than residential, the following additional provisions of means of access shall be ensured:

- a) The width of the main street on which the building abuts shall not be less than 12 m and one end of this street shall join another street not less than 12 m in width;
- b) The approach to the building and open spaces on all its sides up to 6 m width and the layout for the same shall be done in consultation with the Chief Fire Officer of the city and the same shall be hard surface capable of taking the mass of fire engine, weighing up to 45 tonnes. The said open space shall be kept free of obstructions and shall be motorable.
- c) The main entrance to the plot shall be of adequate width to allow easy access to the fire engine and in no case shall it measure less than 6 m. The entrance gate shall fold back against the compound wall of the premises, thus leaving the exterior accessway within the plot free for movement of fire service vehicle. If the main entrance at the boundary wall is built over, the minimum clearance shall be 4.5 m. A turning radius of 9 m shall be provided for fire tender movement.

4.7 Cul-de-sacs giving access to plots and extending from 150 m to 275 m in length with an additional turning space at 150 m will be allowed only in residential areas, provided cul-de-sacs would be permissible only on straight roads and further provided the end of cul-de-sacs shall be higher in level than the level of the starting point of such dead end road. The turning space, in this case shall be not less than 81 m² in area, with no dimension less than 9 m.

4.8 Intersection of Roads

For intersection junctions of roads meeting at right angles as well as other than right angles, the rounding off or cut off or splay or similar treatment shall be done, to the approval of the Authority, depending upon the width of roads, the traffic generated, the sighting angle, etc, to provide clear sight distance.

4.9 The building line shall be set back at least 3 m from internal means of access in a layout of buildings in a plot subject to provisions of **8.2.1**.

5 COMMUNITY OPEN SPACES AND AMENITIES

5.1 Residential and Commercial Zones

In any layout or sub-division of land measuring 0.3 hectare or more in residential and commercial zones, the community open spaces shall be reserved for recreational purposes which shall as far as possible be provided in one place or planned out for the use of the community in clusters or pockets.

5.1.1 The community open spaces shall be provided

catering to the needs of area of layout, population for which the layout is planned and the category of dwelling units. The following minimum provision shall be made:

- a) 15 percent of the area of the layout, or
- b) 0.3 to 0.4 ha/1 000 persons; for low income housing the open spaces shall be 0.3 ha/1 000 persons.

5.2 No recreational space shall generally be less than 450 m².

5.2.1 The minimum average dimension of such recreational space shall be not less than 7.5 m; if the average width of such recreational space is less than 24 m, the length thereof shall not exceed 2.5 times the average width. However, depending on the configuration of the site, commonly open spaces of different shapes may be permitted by the Authority, as long as the open spaces provided serve the needs of the immediate community contiguous to the open spaces.

5.2.2 In such recreational spaces, a single storeyed structure as pavilion or gymnasia up to 25 m² in area may be permitted; such area may be excluded from FAR calculations.

5.3 Each recreational area and the structure on it shall have an independent means of access. Independent means of access may not be insisted upon if recreational space is approachable directly from every building in the layout. Further, the building line shall be at least 3 m away from the boundary of recreational open space.

5.4 Industrial Zones

In the case of sub-division of land in industrial zones of area 0.8 hectare or more, 5 percent of the total area shall be reserved as amenity open space which shall also serve as a general parking space; when such amenity open space exceeds 1 500 m², the excess area could be utilized for the construction of buildings for banks, canteens, welfare centres and such other common purposes considered necessary for the industrial user, as approved by the Authority.

5.4.1 In all industrial plots measuring 1 000 m² or more in area, 10 percent of the total area shall be provided as an amenity open space to a maximum of 2 500 m². Such an amenity open space shall have a means of access and shall be so located that it could be conveniently utilized as such by the persons working in the industry.

5.5 Other Amenities

In addition to community open spaces, the layouts shall provide for the amenities as given in **5.5.1** to **5.5.6**. These provisions may be modified based on specific requirements, as decided by the Authority.

5.5.1 Educational Facilities

Land Area Required, Min

a) **Pre-Primary to Secondary Education**

- 1) *Pre-primary, nursery school (1 for every 2 500 population)*
 - i) Area per school 0.08 ha
 - ii) Location of pre-primary/nursery school Near a park
- 2) *Primary school (class 1 to 5) (1 for every 5 000 population)*
 - i) Strength of school — 500 students
 - ii) Area per school 0.40 ha
 - a) School building area 0.20 ha
 - b) Play field area (with a minimum of 18 m × 36 m to be ensured for effective play) 0.20 ha
- 3) *Senior secondary school (class 6 to 12) (1 for every 7 500 population)*
 - i) Strength of the school — 1 000 students
 - ii) Area per school 1.80 ha
 - a) School building area 0.60 ha
 - b) Play field area (with a minimum of 68 m × 126 m to be ensured for effective play) 1.00 ha
 - c) Parking area 0.20 ha
- 4) *Integrated school without hostel facility (class 1 to 12) (1 for every 90 000 to 100 000 population)*
 - i) Strength of the school—1 500 students
 - ii) Area per school 3.50 ha
 - a) School building area 0.70 ha
 - b) Play field area 2.50 ha
 - c) Parking 0.30 ha
- 5) *Integrated school with hostel facilities (class 1 to 12) (1 for every 90 000 to 100 000 population)*
 - i) Strength of school — 1 500 students
 - ii) Area per school 3.90 ha
 - a) School building area 0.70 ha
 - b) Play field area 2.50 ha
 - c) Residential (including hostel area) 0.40 ha
 - d) Parking area 0.30 ha
- 6) *School for physically challenged (class 1 to 12) (1 for every 45 000 population)*
 - i) Strength of school — 400 students
 - ii) Area per school 0.70 ha
 - a) School building area 0.20 ha
 - b) Play field area 0.30 ha
 - c) Parking area 0.20 ha

b) **Higher Education — General**

- 1) *College (1 for every 125 000 population)*
 - i) Student strength of college — 1 000 to 1 500 students
 - ii) Area per college 5.00 ha
 - a) College building area 1.80 ha
 - b) Play field area 2.50 ha
 - c) Residential (including hostel area) 0.40 ha
 - d) Parking area 0.30 ha
- 2) *University campus/centre area* 10.00 ha
- 3) *New university area* 60.00 ha

c) Technical Education

- 1) *Technical education centre (A) (1 for every 1 000 000 population to include 1 ITI and 1 polytechnic)*
 - i) Strength of ITI — 400 students
 - ii) Strength of polytechnic — 500 students
 - iii) Area per technical education centre 4.00 ha
 - a) Area for ITI 1.60 ha
 - b) Area for polytechnic 2.40 ha
- 2) *Technical education centre (B) (1 for every 1 000 000 population to include 1 ITI, 1 technical centre and 1 coaching centre)*

Area per technical education centre 4.00 ha

 - a) Area for ITI 1.60 ha
 - b) Area for technical centre 2.10 ha
 - c) Area for coaching centre 0.30 ha

d) Professional Education

- 1) *Engineering college (1 for every 1 000 000 population)*
 - i) Strength of the college — 1 500 students
 - ii) Area per college 6.00 ha
- 2) *Medical college (1 for every 1 000 000 population)*

Area of site including space for general hospital 15.00 ha
- 3) *Other professional colleges (1 for every 1 000 000 population)*
 - i) Area of site for students strength upto 250 students 2.00 ha
 - ii) Additional area of site for every additional 100 students or part thereof upto total strength of 1 000 students 0.50 ha
 - iii) Area of site for strength of college — From 1 000 to 1 500 students 6.00 ha

5.5.2 Health Care Facilities

- 1) *Dispensary (1 for every 15 000 population)*

Area 0.08 ha to 0.12 ha
- 2) *Nursing home, child welfare and maternity centre (1 for every 45 000 to 100 000 population)*
 - i) Capacity 25 to 30 beds
 - ii) Area 0.20 ha to 0.30 ha
- 3) *Poly-clinic with some observation beds (1 for every 100 000 population)*

Area 0.20 ha to 0.30 ha
- 4) *Intermediate hospital (category B) (1 for every 100 000 population)*
 - i) Capacity 80 beds (initially the provision may be for 50 including 20 maternity beds)
 - ii) Total area 1.00 ha
 - a) Area for hospital 0.60 ha
 - b) Area for residential accommodation 0.40 ha
- 5) *Intermediate hospital (category A) (1 for every 100 000 population)*
 - i) Capacity 200 beds (initially the provision may be for 100 beds)
 - ii) Total area 3.70 ha
 - a) Area for hospital 2.70 ha
 - b) Area for residential accommodation 1.00 ha

	<i>Land Area Required, Min</i>
6) <i>General hospital (1 for every 250 000 population)</i>	
i) Capacity 500 beds (initially the provision may be for 300 beds)	
ii) Total area	6.00 ha
a) Area for hospital	4.00 ha
b) Area for residential accommodation	2.00 ha
7) <i>Multi-speciality hospital (1 for 100 000 population)</i>	
i) Capacity 200 beds (initially the provision may be for 100 beds)	
ii) Total area	9.00 ha
a) Area for hospital	6.00 ha
b) Area for residential accommodation	3.00 ha
8) <i>Speciality hospital (1 for every 100 000 population)</i>	
i) Capacity 200 beds (initially the provision may be for 100 beds)	
ii) Total area	3.70 ha
a) Area for hospital	2.70 ha
b) Area for residential accommodation	1.00 ha

5.5.3 Socio-cultural facilities

	<i>Land Area Required, Min</i>
1) <i>Community room (1 for every 5 000 population)</i>	
Area	750 m ²
2) <i>Community hall, mangal karyayala/kalyana mandapam/barat ghar/library (1 for every 15 000 population)</i>	
Area	2 000 m ²
3) <i>Recreational club (1 for every 100 000 population) (see also 5.2, 5.2.1, 5.2.2 and 5.3)</i>	
Area	10 000 m ²
4) <i>Music, dance and drama centre (1 for every 100 000 population)</i>	
Area	1 000 m ²
5) <i>Meditation and spiritual centre (1 for every 100 000 population)</i>	
Area	5 000 m ²
6) <i>Socio-cultural centre (1 for every 1 000 000 population)</i>	
Area	15 ha

5.5.4 Distribution Services

	<i>Land Area Required, Min</i>
1) <i>Petrol/diesel filling and servicing centre</i>	
May be permitted in central as well as sub-central business district, district centres, community centres (only filling station), residential and industrial use zones in urban areas, along the national highways, state highways, villages identified as growth centres, freight complex and on proposed major roads.	
Shall not be located on the road having right of way less than 30 m.	
Shall be approved by the explosive/fire department.	
Area/Size	
i) Only filling station	30 m × 17 m
ii) Filling-cum-service station	36 m × 30 m
iii) Filing-cum-service station-cum-workshop	45 m × 36 m
iv) Filling station only for two and three wheelers	18 m × 15 m
2) <i>Compressed natural gas (CNG)/filling centre</i>	
Permitted in all use zones (except in regional parks and Developed District Parks) and along the national highways, state highways and villages identified as growth centres, freight complex and on proposed major roads	

	<i>Land Area Required, Min</i>
Shall not be located on the road having right of way less than 30 m.	
Shall be approved by the explosive/fire department.	
Area/size for mother station (building component—control room/office/dispensing room, store, pantry and W.C.)	1 080 m ² (36 m × 30 m)
3) <i>LPG godowns/Gas godown 1 for every 40 000 to 50 000 population</i>	
The major concern for its storage and distribution is the location which shall be away from the residential areas and shall have open spaces all around as per the <i>Explosive Rules</i> .	
i) Capacity — 500 cylinders or 8 000 kg of LPG	520 m ²
ii) Area (inclusive of chowkidar hut)	(26 m × 20 m)
4) <i>Milk distribution (1 milk booth for every 5 000 population)</i>	
Area inclusive of service area	150 m ²

5.5.5 Police, Civil Defence and Home Guards

	<i>Land Area Required, Min</i>
1) <i>Police station (1 for every 90 000 population)</i>	
Area (inclusive of essential residential accommodation 0.05 ha additional to be provided for civil defence and home guards)	1.50 ha
2) <i>Police post (1 for every 40 000 to 50 000 population) (not served by a police station)</i>	
Area (inclusive of essential residential accommodation)	0.16 ha
3) <i>District office and battalion (1 for every 1 000 000 population)</i>	
i) Area for district office	0.80 ha
ii) Area for battalion	4.00 ha
iii) Total area	4.80 ha
4) <i>Police line (1 for every 2 000 000 population)</i>	
Area	4.00 to 6.00 ha
5) <i>District Jail (1 for every 1 000 000 population)</i>	
Area	10.00 ha
6) <i>Civil defence and home guards (1 for every 1 000 000 population)</i>	
Area	2.00 ha

5.5.6 Fire

	<i>Land Area Required, Min</i>
<i>One fire station or sub-fire station within 1 km to 3 km (for every 200 000 population)</i>	
i) Area for fire station with essential residential accommodation	1.00 ha
ii) Area for sub-fire station with essential residential accommodation	0.60 ha

5.5.7 Telephone, Telegraphs, Postal and Banking Facilities

	<i>Land Area Required, Min</i>
a) Telephone and Telegraphs	
1) <i>Telephone exchange of 40 000 lines (1 for every 400 000 population)</i>	
Area	4.00 ha
2) <i>Telegraph booking counter (1 for every 100 000 population)</i>	
Floor area to be provided in community centre	200 m ²
3) <i>Telegraph booking and delivery office (1 for every 500 000 population)</i>	
Floor area to be provided in district centres	1 700 m ²

	<i>Land Area Required, Min</i>
b) Postal	
1) <i>Post office counter without delivery (1 for every 15 000 population)</i> Floor area to be provided in local shopping centre	85 m ²
2) <i>Head post office with delivery office (1 for 250 000 population)</i> Area	750 m ²
3) <i>Head post office and administrative office (1 for 500 000 population)</i> Area	2 500 m ²
c) Banking	
1) <i>Extension counters with ATM facility (1 for every 15 000 population)</i>	
i) Floor area for counters	75 m ²
ii) Floor area for ATM	6 m ²
2) <i>Bank with locker, ATM and other banking facilities (1 for 100 000 population)</i> Area	2 500 m ²

5.5.8 Sports Activity

	<i>Land Area Required, Min</i>
1) <i>Divisional sports centre (1 for 1 000 000 population)</i> Area	20.00 ha
2) <i>District sport centre (1 for 100 000 population)</i> Area	8.00 ha
3) <i>Neighbourhood play area (1 for 15 000 population)</i> Area	1.50 ha
4) <i>Residential unit play area (1 for 5 000 population)</i> Area	5 000 m ²

5.5.9 Shopping

	<i>Land Area Required, Min</i>
1) <i>Convenience shopping (1 for 5 000 population)</i> Area	1 500 m ²
2) <i>Local shopping including service centre (1 for 15 000 population)</i> Area	4 600 m ²
3) <i>Community centre with service centre (1 for 100 000 population)</i> Area	5.00 ha
4) <i>District centre (1 at district level/1 for 500 000 population)</i> Area	7.50 ha
5) <i>Local wholesale market (1 for 1 000 000 population)</i> Area	10.00 ha
6) <i>Weekly markets (1 to 2 locations for every 100 000 populations with 300 to 400 units per location)</i> Parking and other open spaces within the commercial centres could be so designed that weekly markets can operate in these areas during non-working hours. The area of informal sector should have suitable public conveniences and solid waste disposal arrangements. Area per location	0.40 ha
7) <i>Organized informal sector eating places (1 for 100 000 population)</i> Area	2 000 m ²

5.5.10 Religious

	<i>Land Area Required, Min</i>
1) Religious campus (1 for 100 000 population) Area	5.00 ha

5.5.11 Electrical Sub-station

	<i>Land Area Required, Min</i>
1) 11 kV Sub-station (1 for 15 000 population) Area	500 m ²
2) 66 kV Sub-station (2 for 100 000 population) Area for each Sub-station	6 000 m ² (that is 60 m × 100 m)
3) 220 kV Sub-station (1 for 500 000 population) Area	4.00 ha

5.5.12 Transport

	<i>Land Area Required, Min</i>
1) Three wheeler and taxi stand (1 for 15 000 population) Area	500 m ²
2) Bus terminal (1 for 100 000 population) Area	4 000 m ²
3) Bus depot (1 for 500 000 population) Area	2.00 ha

5.5.13 Cremation/Burial Ground

The site shall be identified in locations, which are not proximate to residential areas

	<i>Land Area Required, Min</i>
1) Electric crematorium (1 for large size towns) Area	2.00 ha
2) Cremation ground (1 for 500 000 population) Area	2.50 ha
3) Burial ground (1 for 500 000 population) Area	4.00 ha

5.5.14 Dhobi Ghat

	<i>Land Area Required, Min</i>
1) Dhobi ghat with appropriate arrangements for water and drainage facilities and it shall be ensured that the water bodies are not polluted as a result of such activities (1 for 100 000 population) Area	5 000 m ²

5.6 Every layout or sub-division shall take into account the provisions of development plan and if the land is affected by any reservation for public purposes, the Authority may agree to adjust the location of such reservations to suit the development.

6 REQUIREMENTS OF PLOTS

6.1 No building shall be constructed on any site, on any part of which there is deposited refuse, excreta or other offensive matter objectionable to the Authority, until such refuse has been removed therefrom and the

site has been prepared or left in a manner suitable for building purposes to the satisfaction to the Authority.

6.2 Damp Sites

Wherever the dampness of a site or the nature of the soil renders such precautions necessary, the ground surface of the site between the walls of any building erected thereon shall be rendered damp-proof to the satisfaction of the Authority.

6.3 Surface Water Drains

Any land passage or other area within the curtilage of a building shall be effectively drained by surface water drains or other means.

6.3.1 The written approval of the Authority shall be obtained for connecting any sub-soil or surface water drain to a sewer.

6.4 Distance from Electric Lines

No *VERANDAH*, balcony, or the like shall be allowed to be erected or re-erected or any additions or alterations made to a building within the distances quoted below in accordance with the current *Indian Electricity Rules* as amended from time-to-time between the building and any overhead electric supply line:

(1)	(2)	Vertically m (3)	Horizontally m (4)
a)	Low and medium voltage lines and service lines	2.5	1.2
b)	High voltage lines up to and including 11 000 V	3.7	1.2
c)	High voltage lines above 11 000 V and up to and including 33 000 V	3.7	2.0
d)	Extra high voltage line beyond 33 000 V	3.7 (plus 0.3 m for every additional 33 000 V or part thereof)	2.0 (plus 0.3 m for every additional 33 000 V or part thereof)

6.5 Distance of site from the normal edge of water course/area may be specified by the Authority, keeping in view the normal maximum flood/tide level.

6.6 Size of Plots

6.6.1 Residential

Each plot shall have a minimum size/frontage

corresponding to the type of development as given below:

Type of Development (1)	Plot Size m ² (2)	Frontage m (3)
Detached building	Above 250	Above 12
Semi-detached building	125-250	8 to 12
Row type building	50-125	4.5 to 8

NOTE — For low income housing see 12.20.

6.6.1.1 The minimum size of the site for group housing development shall be as given in the Master Plan and local development control rules.

6.6.2 Industrial

The size of the plot shall not be less than 300 m² and its width shall not be less than 15 m.

6.6.3 Other Land Uses

The minimum size of plots for buildings for other uses not covered under 5.5 shall be as decided by the Authority.

7 CLASSIFICATION OF BUILDINGS

7.0 Buildings are classified based on occupancy and types of construction.

7.1 For the purpose of the Code, the following shall be the occupancy classification and types of construction; for more detailed information, reference may be made to Part 4 'Fire and Life Safety'.

7.1.1 Occupancy Classification

- a) Residential;
- b) Educational;
- c) Institutional;
- d) Assembly;
- e) Business;
- f) Mercantile (will include both retail and wholesale stores);
- g) Industrial (will include low, moderate and high fire hazards);
- h) Storage; and
- j) Hazardous.

7.1.2 Types of Construction

- a) Type 1,
- b) Type 2,
- c) Type 3, and
- d) Type 4.

8 OPEN SPACES (WITHIN A PLOT)

8.1 General

Every room intended for human habitation shall abut on an interior or exterior open space or an open *VERANDAH* open to such interior or exterior open space.

8.1.1 The open spaces inside and around a building have essentially to cater for the lighting and ventilation requirements of the rooms abutting such open spaces, and in the case of buildings abutting on streets in the front, rear or sides, the open spaces provided shall be sufficient for the future widening of such streets.

8.1.2 *Open Spaces Separate for each Building or Wing*

The open spaces shall be separate or distinct for each building and where a building has two or more wings, each wing shall have separate or distinct open spaces for the purposes of lighting and ventilation of the wings.

However, separation between accessory and main buildings more than 7 m in height shall not be less than 1.5 m; for buildings up to 7 m in height no such separation shall be required.

8.1.3 The open space shall be the minimum distance measured between the front, rear and side of the building and the respective plot boundaries. The front, rear and side of the building shall be the point of the building nearest to the boundary.

8.2 Residential Buildings

8.2.1 *Exterior Open Spaces*

8.2.1.1 *Front open space*

- a) Every building fronting a street shall have a front space, forming an integral part of the site as below:

<i>Sl No.</i>	<i>Front Open Space, Min m</i>	<i>Width of Street Fronting the Plot m</i>
(1)	(2)	(3)
i)	1.5 ¹⁾	Up to 7.5 ¹⁾
ii)	3.0	7.5 to 18
iii)	4.5	18 to 30
iv)	6.0	Above 30

¹⁾ For buildings up to a maximum height 7 m.

NOTE — In case a building abuts two or more streets, the value of open spaces is to be based on the average width of streets, subject to a minimum of 1.8 m for cases (ii), (iii) and (iv) above.

- b) For streets less than 7.5 m in width, the distance of the building (building line) shall

be at least 5 m from the centre line of the street (see 4.3.5).

NOTE — This limiting distance has to be determined by the Authority for individual road/street widths taking into account the traffic flow.

8.2.1.2 *Rear open space*

- a) Every residential building shall have a rear open space, forming an integral part of the site, of an average width of 3 m and at no place measuring less than 1.8 m, except that in the case of a back-to-back sites, the width of the rear open space shall be 3 m throughout. Subject to the condition of free ventilation, the open space left up to half the width of the plot shall also be taken into account for calculating the average width of the rear open space. For plots of depths less than 9 m, for buildings up to 7 m in height, the rear open space may be reduced to 1.5 m.
- b) *Rear open space to extend the rear wall*
The rear open space shall be co-extensive with the entire face of the rear wall. If a building abuts on two or more streets, such rear open space shall be provided throughout the face of the rear wall. Such rear wall shall be the wall on the opposite side of the face of the building abutting on the wider street unless the Authority directs otherwise.
- c) In case of corner plots less than 300 m² in area, the rear open space should be 2.4 m minimum.

8.2.1.3 *Side open space*

- a) Every semi-detached and detached building shall have a permanently open air space, forming an integral part of the site as below:
- 1) For detached buildings there shall be a minimum side open space of 3 m on both the sides.
NOTE — For detached residential buildings up to 7 m in height on plots with a frontage less than 12 m (see 6.6.1), one of the side open spaces may be reduced to 1.5 m.
 - 2) For semi-detached buildings, there shall be a minimum side open space of 3 m on one side.
NOTE — For semi-detached buildings up to 7 m in height on plots with a frontage less than 9 m (see 6.6.1), the side open spaces may be reduced to 1.5 m.
 - 3) For row-type buildings, no side open is required.
- b) In the case of semi-detached buildings, the open spaces provided on one side shall be as

in 8.2.1.3 (a) and all habitable rooms shall abut either on this side open space or front and rear open spaces or an interior open space (see 8.2.5).

8.2.2 The provisions of 8.2.1.2 and 8.2.1.3 are not applicable to parking lock-up garages up to 3 m in height located at a distance of 7.5 m from any street line or front boundary of the plot.

8.2.3 The open spaces mentioned in 8.2.1.1 to 8.2.1.3 shall be for residential buildings up to a height of 10 m.

8.2.3.1 For buildings of height above 10 m, the open spaces (side and rear) shall be as given in Table 2. The front open spaces for increasing heights of buildings shall be governed by 9.4.1 (a).

Table 2 Side and Rear Open Spaces for Different Heights of Buildings
(Clause 8.2.3.1)

Sl No.	Height of Buildings	Side and Rear Open Spaces to be Left Around Building
		m
(1)	(2)	(3)
i)	10	3
ii)	15	5
iii)	18	6
iv)	21	7
v)	24	8
vi)	27	9
vii)	30	10
viii)	35	11
ix)	40	12
x)	45	13
xi)	50	14
xii)	55 and above	16

NOTES

1 For buildings above 24 m in height, there shall be a minimum front open space of 6 m.

2 Where rooms do not derive light and ventilation from the exterior open space, the width of such exterior open space as given in col 3 may be reduced by 1 m subject to a minimum of 3 m and a maximum of 8 m. No further projections shall be permitted.

3 If the length or depth of the building exceeds 40 m, add to col (3) 10 percent of length or depth of building minus 4.0 m.

8.2.3.2 For tower-like structures, as an alternative to 8.2.3.1, open spaces shall be as below:

- Up to a height of 24 m, with one set-back, the open spaces at the ground level, shall be not less than 6 m;
- For heights between 24 m and 37.5 m with one set-back, the open spaces at the ground level, shall be not less than 9 m;
- For heights above 37.5 m with two set-backs, the open spaces at the ground level, shall be not less than 12 m; and

- The deficiency in the open spaces shall be made good to satisfy 8.2.3.1 through the set-backs at the upper levels; these set-backs shall not be accessible from individual rooms/flats at these levels.

8.2.4 The front open space would govern the height of the building (see 9.4).

8.2.5 Interior Open Spaces

- Inner courtyard** — In case the whole of one side of every room excepting bath, WC and store room is not abutting on either the front, rear or side open spaces, it shall abut on an inner courtyard, whose minimum width shall be 3 m.

Further, the inner courtyard shall have an area, throughout its height, of not less than the square of one-fifth the height of the highest wall abutting the courtyard. Provided that when any room (excluding staircase bay, bathroom and water-closet) is dependent for its light and ventilation on an inner courtyard, the dimension shall be such as is required for each wing of the building.

Where only water-closet and bath room are abutting on the interior courtyard, the size of the interior courtyard shall be in line with the provision for ventilation shaft as given in 8.2.5 (b).

- Ventilation shaft** — For ventilating the spaces for water-closets and bath rooms, if not opening on to front, side, rear and interior open spaces, these shall open on the ventilation shaft, the size of which shall not be less than the values given below:

Height of Buildings	Size of Ventilation Shaft	Minimum One Dimension of the Shaft
m	m ²	m
(1)	(2)	(3)
Up to 10	1.2	0.9
12	2.8	1.2
18	4.0	1.5
24	5.4	1.8
30	8.0	2.4
Above 30	9.0	3.0

NOTES

1 For buildings of height above 30 m, a mechanical ventilation system shall be installed besides the provision of minimum ventilation shaft.

2 For fully air-conditioned residential buildings for lodging purposes, the ventilation shaft need not be insisted upon, provided the air-conditioning system works in an uninterrupted manner, also, provided there is an alternative source of power supply.

- c) *Outer courtyard* — The minimum width of the outer courtyard (as distinguished from its depth) shall be not less than 2.4 m. If the width of the outer courtyard is less than 2.4 m, it shall be treated as a notch and the provisions of outer courtyard shall not apply. However, if the depth of the outer courtyard is more than the width, the provisions of **8.1.2** shall apply for the open spaces to be left between the wings.

8.2.6 Joint Open Air Space

Every such interior or exterior open air space, unless the latter is a street, shall be maintained for the benefit of such building exclusively and shall be entirely within the owner's own premises.

8.2.6.1 If such interior or exterior open air space is intended to be used for the benefit of more than one building belonging to the same owner, the width of such open air space shall be the one specified for the tallest building as specified in **8.2.3** abutting on such open air space.

8.2.6.2 If such interior or exterior open air space is jointly owned by more than one person, its width shall also be as specified in **8.2**, provided every such person agrees in writing to allow his portion of such joint open air space to be used for the benefit of every building abutting on such joint open air space and provided he sends such written consent to the Authority for record. Such common open air space shall thenceforth be treated as a permanently open air space required for the purposes of the Code. No boundary wall between such joint open air space shall be erected or raised to a height of more than 2.0 m.

8.3 Other Occupancies

8.3.1 Open spaces for other occupancies shall be as below:

- a) *Educational buildings* — Except for nursery schools, the open spaces around the building shall be not less than 6 m.
- b) *Institutional buildings* — The open spaces around the building shall be not less than 6 m.
- c) *Assembly buildings* — The open space at front shall be not less than 12 m and the other open spaces around the building shall be not less than 6 m.
NOTE — However, if assembly buildings are permitted in purely residential zones, the open spaces around the building shall be not less than 12 m.
- d) *Business, mercantile and storage buildings* — The open spaces around the building shall be not less than 4.5 m. Where these occur in a purely residential zone or in a residential with

shops line zone the open spaces may be relaxed.

- e) *Industrial buildings* — The open spaces around the building shall be not less than 4.5 m for heights up to 16 m, with an increase of the open spaces of 0.25 m for every increase of 1 m or fraction thereof in height above 16 m.

NOTE — Special rules for narrow industrial plots in the city, namely plots less than 15 m in width, and with appropriate set-backs from certain streets and highways, shall be applicable.

- f) *Hazardous occupancies* — The open spaces around the building shall be as specified for industrial buildings [see **8.3.1** (e)].

8.4 Exemption to Open Spaces

8.4.1 Projections into Open Spaces

Every open space provided either interior or exterior shall be kept free from any erection thereon and shall be open to the sky, except as below:

- a) Cornice, roof or weather shade not more than 0.75 m wide;
- b) Sunshades over windows/ventilators or other openings not more than 0.75 m wide;
- c) Canopy not to be used as a sit out with clearance of 1.5 m between the plot boundary and the canopy;
- d) Projected balcony at higher floors of width not more than 1.2 m; and
- e) Projecting rooms/balconies [see (d)] at alternate floors such that rooms of the lower two floors get light and air and the projection being not more than the height of the storey immediately below.

However, these projections into open spaces shall not reduce the minimum required open spaces.

8.4.1.1 Accessory building

The following accessory buildings may be permitted in the open spaces:

- a) In an existing building, sanitary block of 2.4 m in height subject to a maximum of 4 m² in the rear open space at a distance of 1.5 m from the rear boundary may be permitted, where facilities are not adequate.
- b) Parking lock up garages not exceeding 2.4 m in height shall be permitted in the side or rear open spaces at a distance of 7.5 m from any road line or the front boundary of the plot; and
- c) Suction tank and pump room each up to 2.5 m² in area.

8.4.2 Projection into Street

8.4.2.1 In existing built-up or congested areas, no projection of any sort whatsoever, except sunshades (see 8.4.2.3) extending more than 23 cm below a height of 4.3 m, shall project over the road or over any drain or over any portion outside the boundaries of the site, provided the projection arising out of the vertical part of the rain-water spouts projecting at the road level or the water pipe may be permitted in accordance with the drainage plan.

8.4.2.2 Porticos in existing developed area

Porticos in bazaar areas of existing developed areas may be permitted to project on road land subject to the following limitations:

- a) Porticos may be allowed on such roads leaving a minimum clear space of 18 m between kerbs;
- b) The porticos shall not be less than 3 m wide;
- c) Nothing shall be allowed to be constructed on the portico which shall be used as an open terrace;
- d) Nothing shall be allowed to project beyond the line of arcades; and
- e) The space under the portico shall be paved and channelled according to the directions of the Authority.

8.4.2.3 Sunshades over windows and ventilators

Projections of sunshades over windows or ventilators in existing built-up or congested areas when permitted by the Authority shall fulfil the following conditions:

- a) No sunshade shall be permitted over the road or over any drain or over any portion outside the boundaries of the site below a height of 2.8 m from the road level;
- b) Sunshades provided above a height of 2.8 m from the ground level shall be permitted to project up to a maximum width of 60 cm, if the road over which they project exceeds 9 m in width; and
- c) No sunshade shall be permitted on roads less than 9 m in width or on roads having no footpaths.

8.5 Limitations to Open Spaces

8.5.1 Safeguard Against Reduction of Open Space

No construction work on a building shall be allowed if such work operates to reduce an open air space of any other adjoining building, belonging to the same owner to an extent less than what is prescribed at the time of the proposed work or to reduce further such open space if it is already less than that prescribed.

8.5.2 Additions or Extensions to a Building

Additions or extensions to a building shall be allowed, provided the open spaces for the additions/extensions satisfy 8.2 after such additions/extensions are made.

9 AREA AND HEIGHT LIMITATIONS

9.1 General

The limitation of area and height of buildings of different occupancy classes and types of construction shall be achieved by specifying it in terms of FAR, which shall take into account the various aspects that govern in specifying FAR as given below:

- a) Occupancy class;
- b) Types of construction;
- c) Width of street fronting the building and the traffic load;
- d) Locality where the building is proposed and the density;
- e) Parking facilities;
- f) Local fire fighting facilities; and
- g) Water supply and drainage facilities.

9.2 The comparative FAR's for different occupancies and types of construction are as given in Table 3 and the Authority shall select a basic FAR for one occupancy and a type of construction and arrive at the FAR values for other combinations taking into account the other local factors (see 9.1).

9.2.1 Unlimited Areas

The minimum fire separation on all sides of buildings of unlimited areas (see Table 3) and of Type 1 construction shall be 9 m.

9.3 Street Width

The area limits shall apply to all buildings fronting on a street or public space not less than 9 m in width accessible to a public street.

9.4 Height Limit

The height and number of storeys shall be related to FAR and the provisions of 8.

9.4.1 Where a building height is not covered by Table 3, the maximum height shall be limited according to the width of the street as follows:

- a) The maximum height of building shall not exceed 1.5 times the width of road abutting plus the front open space;
- b) If a building abuts on two or more streets of different widths, the building shall be deemed to face upon the street that has the greater width and the height of the building shall be

Table 3 Comparative Floor Area Ratios for Occupancies Facing One Public Street of at Least 9 m Width

(Clauses 2.26, 9.2 and 9.2.1)

Occupancy Classification	Type of Construction			
	Type 1	Type 2	Type 3	Type 4
(1)	(2)	(3)	(4)	(5)
Residential	UL	2.0	1.4	1.0
Educational	UL	2.0	1.4	1.0
Institutional	UL	1.5	1.0	0.8
Assembly	UL	1.0	0.7	0.5
Business	UL	2.9	2.3	1.6
Mercantile	8.0	1.8	1.4	1.0
Industrial	7.5	1.9	1.6	1.3
Storage (see Note 4)	6.0	1.5	1.3	1.0
Hazardous (see Note 4)	2.8	1.1	0.9	NP

UL — Unlimited

NP — Not Permitted

NOTES

1 This table has been prepared, taking into account the combustible content in the different occupancies as well as the fire resistance offered by the type of construction (see Part 4 'Fire and Life Safety').

2 This table shall be modified by the Authority, taking into account the other aspects as given below (see **9.1**):

- Density in terms of dwelling units/hectare;
- Traffic considerations;
- Parking spaces;
- Local fire fighting facilities; and
- Water supply, drainage and sanitation requirements.

3 The FAR specified may be increased by 20 percent for the following:

- A basement or cellar and space under a building constructed on stilts and used as a parking space, and air-conditioning plant room used as accessory to the principal use;
- Electric cabin or sub-station, watchman's booth of maximum size of 1.6 m² with minimum width or diameter of 1.2 m, pumphouse, garbage shaft, space required for location of fire hydrants, electric fittings and water tank;
- Projections and accessory buildings as specifically exempted (see **8.4.1**); and
- Staircase room and lift rooms above the topmost storey, architectural features; and chimneys and elevated tanks of dimensions as permissible under the Code; the area of the lift shaft shall be taken only on one floor.

4 In so far as single storey storage and hazardous occupancies are concerned, they would be further governed by volume to plot area ratio (VPR), to be decided by the Authority.

regulated by the width of that street and may be continued to this height to a depth of 24 m along the narrower street subject to conformity of **8**; and

- For buildings in vicinity of aerodromes, provisions of **9.5** shall apply.

9.4.2 Height Exceptions

9.4.2.1 Roof structures

The following appurtenant structures shall not be included in the height of the building unless the aggregate area of such structures, including pent-houses, exceeds one-third of the area of the roof of building upon which they are erected:

- Roof tanks and their supports (with support height not exceeding 1 m);
- Ventilating, air-conditioning, lift rooms and similar service equipment;
- Stair cover (*MUMTY*) not exceeding 3 m in height; and
- Chimneys, parapet walls and architectural features not exceeding 1.2 m in height.

9.4.2.2 The building height for different occupancy types shall not exceed the maximum height prescribed in Part 4 'Fire and Life Safety'.

9.5 Restrictions in the Vicinity of Aerodromes

9.5.1 For buildings in the vicinity of aerodromes, the maximum height of such buildings shall be decided in consultation with the Civil Aviation Authorities. This shall be regulated by the rules for giving no objection certificate for construction of buildings in the vicinity of aerodromes of Directorate General of Civil Aviation, which are given in Annex A. However, the latest rules of Directorate General of Civil Aviation shall be followed in all cases of buildings coming up in the vicinity of an aerodrome.

9.5.1.1 For the purpose of **9.5.1** new buildings, structures which rise to 30 m or more in height and are to be located within 20 km of the aerodrome reference point, shall be constructed only if no objection certificate has been obtained from the Directorate General of Civil Aviation.

9.5.1.2 In the case of buildings to be erected in the vicinity of defence aerodromes, the maximum height of such buildings shall be decided by the Defence Authority.

9.5.2 This will apply specially to new constructions, overhead high voltage/medium voltage lines, telephones/telegraph lines, factories, chimneys, wire/TV antennas.

9.5.2.1 No new chimneys or smoke producing factories shall be constructed within a radius of 8 km from the aerodrome reference point (ARP).

9.5.2.2 Overhead high voltage/medium voltage lines or telephone/telegraph lines shall not be permitted in the approach/take-off climb areas within 3 000 m of the inner edge of these areas.

9.5.2.3 A 3 m margin shall be allowed in new constructions for wireless/TV antennas, cooling towers and *MUMTIES*.

9.5.3 Butcheries, tanneries and solid waste disposal sites shall not be permitted within 10 km from the aerodrome reference point.

9.6 Group Housing

9.6.1 Group housing development may be in low rise house clusters or multi-storeyed apartments for high density development.

9.6.2 No limit to floors and height shall be applicable, but the coverage and floor area ratio for various densities may be as given in Table 4 unless otherwise provided in the Master Plan and local development control rules.

Table 4 Floor Area Ratio and Coverage for Group Housing
(Clause 9.6.2)

Sl No.	Net Residential Density in Dwelling Units/ Hectare	Maximum Coverage in Percent	Floor Area Ratio
(1)	(2)	(3)	(4)
i)	25	25	0.50
ii)	50	30	0.75
iii)	75	33	0.90
iv)	100	35	1.00
v)	125	35	1.25
vi)	150	35	1.50
vii)	175	35	1.75

NOTE — The coverage shall be calculated on the basis of the whole area reserved for group housing.

9.6.3 The minimum size of the site for group housing multi-storeyed apartment shall be 3 000 m².

9.6.3.1 The number of dwelling units are calculated on the basis of the density pattern given in the Development Plan taking into consideration a population of 4.5 persons per dwelling unit.

9.6.3.2 The basement may vary between 33.33 to 50 percent of the plot area and is to be used for parking, servicing and for essential household storage without counting in FAR.

9.6.3.3 One car parking space for every two flats up to 90 m² floor area and one for every flat for 100 m² or more shall be provided.

9.6.4 With a view to providing adequate parking for occupancies and the vehicular load, appropriate off-street parking provisions have to be made in the building/on-site. This could also be permitted in basement areas and the footprint for the basement parking can exceed the ground coverage of the building subject to no basement building construction

to cross the building line and all other safety features for structural, fire, health and public safety being ensured.

10 OFF-STREET PARKING SPACES

10.1 The off-street parking (on-site parking) spaces in a plot to be provided shall be in accordance with Annex B. The spaces given in Annex B shall be considered by the Authority in conjunction with the Development Rules, in force, if any.

10.2 The spaces to be left out for off-street parking as given in **10.3** to **10.6** shall be in addition to the open spaces left out for lighting and ventilation purposes as given in **15**.

10.2.1 Further 50 percent of the open spaces required around buildings under **8** may be allowed to be utilized for parking or loading or unloading spaces, provided a minimum distance of 3.6 m around the building is kept free from any parking, loading or unloading spaces subject to the provisions of Part 4 'Fire and Life Safety'.

10.3 Each off-street parking space provided for vehicles shall be as follows:

- For car, the minimum parking space to be 3 m × 6 m when individual parking space is required and 2.75 m × 5 m when common parking space is required.
- Space for scooter/two wheeler and bicycle to be not less than 1.25 m² and 1.00 m² respectively.
- Area for each equivalent car space inclusive of circulation area is 23 m² for open parking, 28 m² for ground floor covered parking and 32 m² for basement.

10.4 For buildings of different occupancies, off-street parking space for vehicles shall be provided as stipulated below:

- Motor Vehicles* — Space shall be provided as specified in Annex B for parking motor vehicles (cars).
- Other Types of Vehicles* — For non-residential building, in addition to the parking areas provided in (a) above, 25 to 50 percent additional parking space shall be provided for parking other types of vehicles and the additional spaces required for other vehicles shall be as decided by the Authority, keeping in view the nature of traffic generated in the city.

10.5 Off-street parking space shall be provided with adequate vehicular access to a street; and the area of drives, aisles and such other provisions required for adequate manoeuvring of vehicle shall be exclusive of the parking space stipulated in these provisions.

10.6 If the total parking space required by these provisions is provided by a group of property owners for their mutual benefits, such use of this space may be construed as meeting the off-street parking requirements under these provisions, subject to the approval of the Authority.

10.7 In buildings of mercantile (commercial), industrial and storage type, in addition to the parking spaces provided, a space at the rate of 3.5 m × 7.5 m, shall be provided for loading and unloading activities, for each 1 000 m² of floor area or fraction thereof.

10.8 Parking spaces shall be paved and clearly marked for different types of vehicles.

10.9 Apart from parking at ground level, provision of underground or multistoreyed parking may be permitted. The parking of vehicles at different level may also be mechanized. In the case of parking spaces provided in basement(s), at least two ramps of adequate width and slope shall be provided, located preferably at opposite ends. In case of underground/multistoreyed parking, special measures with regard to fire safety shall be taken (*see* Part 4 'Fire and Life Safety').

11 GREENBELTS, LANDSCAPING AND WATER CONSERVATION

11.1 General

Greenbelts and landscaping including plantation of shrubs and trees help to certain extent in enhancing the environmental quality.

11.1.1 Planting of trees in streets and in open spaces should be done carefully to take advantage of both shades and sunshine without obstructing the flow of wind circulation and sight. Their advantage for abating glare and for providing cool and/or warm pockets in developed areas should also be taken.

11.2 Norms for Planting of Shrubs and Trees

11.2.1 Suitable provisions may be made for greeneries including plantation of shrubs and trees as a part of environmental protection in general. This aspect shall be taken care of from the initial stage of town and country planning, zoning and planning of development of particular area and group housing. Finally, this aspect shall also be taken into account in planning individual building of different occupancies.

11.2.2 The types of plants, the distance between trees/plants from the building and the distance between plants shall be carefully worked out keeping in view the structural safety and aesthetic requirements of buildings.

11.3 Trees shall be numbered area-wise, plot-wise and road-wise by the concerned authority and they shall be checked periodically.

11.4 Cutting and pruning of trees in public as well as private areas shall be suitably regulated. Trees shall be cut only after obtaining the permission of the Authority designated for this purpose.

11.5 The landscape planning and design shall be done in accordance with Part 10 'Landscaping, Signs and Outdoor Display Structures, Section 1 Landscape Planning and Design'.

11.6 Water Conservation and Augmentation

In view of critical shortage of water, conservation of water by rain water harvesting and by use of recycled water to the maximum extent possible will be required. In this regard the following provisions may be adopted.

11.6.1 The local authority preparing a town-planning scheme or a development plan should see that the local water bodies are preserved, and if dry, are activated by directing water-courses appropriately. If required, the same should be enlarged, deepened, etc.

11.6.2 The water body should be protected by ensuring that no permanent/temporary construction development takes place around it up to a distance of 50 m from the edge of the water body and the same shall be suitably landscaped. Further, the public shall have easy access to the water body.

11.6.3 The rain water run-off shall be suitably directed to Recharging Wells in plots belonging to the local authority and of appropriate design.

11.6.4 The local authority should encourage for collection of rain water from roofs and terraces and direct the same either to a storage tank or to a recharging well.

11.6.5 Buildings having central air-conditioning plants requiring water for cooling purposes may not be allowed to use fresh water for the purpose.

11.6.6 Commercial or residential multi-storey complexes may use recycled water for flushing of toilets. Separate storage tanks and separate distribution pipes shall be provided for the purpose.

12 REQUIREMENTS OF PARTS OR BUILDINGS

12.1 Plinth

12.1.1 Main Buildings

The plinth or any part of a building or outhouse shall be so located with respect to the surrounding ground level that adequate drainage of the site is assured. The height of the plinth shall be not less than 450 mm from the surrounding ground level.

12.1.2 Interior Courtyards and Covered Parking

Every interior courtyard shall be raised at least 150 mm

above the determining ground level and shall be satisfactorily drained.

12.2 Habitable Rooms

12.2.1 Height

The height of all rooms for human habitation shall not be less than 2.75 m measured from the surface of the floor to the lowest point of the ceiling (bottom of slab). In the case of pitched roof, the average height of rooms shall not be less than 2.75 m. The minimum clear head room under a beam, folded plates or eaves shall be 2.4 m. In the case of air-conditioned rooms, a height of not less than 2.4 m measured from the surface of the floor to the lowest point of air-conditioning duct or the false ceiling shall be provided.

12.2.1.1 The requirements of **12.2.1** apply to residential, business and mercantile buildings. For educational and industrial buildings, the following minimum requirements apply:

- a) Educational Buildings Ceiling height 3.6 m for all regions; in cold regions, 3 m
- b) Industrial Buildings Ceiling height 3.6 m, except when air-conditioned, 3 m (*Factory Act 1948* and Rules therein shall govern such heights, where applicable).

12.2.2 Size

The area of habitable room shall not be less than 9.5 m², where there is only one room with a minimum width of 2.4 m. Where there are two rooms, one of these shall not be less than 9.5 m² and the other not less than 7.5 m², with a minimum width of 2.1 m.

12.3 Kitchen

12.3.1 Height

The height of a kitchen measured from the surface of the floor to the lowest point in the ceiling (bottom slab) shall not be less than 2.75 m, except for the portion to accommodate floor trap of the upper floor.

12.3.2 Size

The area of a kitchen where separate dining area is provided, shall be not less than 5.0 m² with a minimum width of 1.8 m. Where there is a separate store, the area of the kitchen may be reduced to 4.5 m². A kitchen, which is intended for use as a dining area also, shall have a floor area of not less than 7.5 m² with a minimum width of 2.1 m.

12.3.3 Other Requirements

Every room to be used as kitchen shall have:

- a) unless separately provided in a pantry, means for the washing of kitchen utensils which

shall lead directly or through a sink to a grated and trapped connection to the waste pipe;

- b) an impermeable floor;
- c) a flue, if found necessary; and
- d) a window or ventilator or opening of size not less than as specified in **15.1.1** subject to increase in area of opening in accordance with Note 3 of **15.1.2**.

12.4 Bathrooms and Water-Closets

12.4.1 Height

The height of a bathroom or water-closet measured from the surface of the floor to the lowest point in the ceiling (bottom of slab) shall not be less than 2.1 m.

12.4.2 Size

The area of a bathroom shall not be less than 1.8 m² with a minimum width of 1.2 m. The floor area of water-closet shall be 1.1 m² with a minimum width of 0.9 m. If bath and water-closet are combined, its floor area shall not be less than 2.8 m² with a minimum width of 1.2 m.

12.4.3 Other Requirements

Every bathroom or water-closet shall:

- a) be so situated that at least one of its walls shall open to external air;
- b) not be directly over or under any room other than another water-closet, washing place, bath or terrace, unless it has a water-tight floor;
- c) have the platform or seat made of water-tight non-absorbent material;
- d) be enclosed by walls or partitions and the surface of every such wall or partition shall be finished with a smooth impervious material to a height of not less than 1 m above the floor of such a room;
- e) be provided with an impervious floor covering, sloping towards the drain with a suitable grade and not towards *VERANDAH* or any other room; and
- f) have a window or ventilator, opening to a shaft or open space, of area not less than 0.3 m² with side not less than 0.3 m.

12.4.4 No room containing water-closets shall be used for any purpose except as a lavatory and no such room shall open directly into any kitchen or cooking space by a door, window or other opening. Every room containing water-closet shall have a door completely closing the entrance to it.

12.5 Ledge or TAND/Loft

12.5.1 Height

The minimum head-room of ledge or TAND/loft shall be 2.2 m. The maximum height of loft shall be 1.5 m.

12.5.2 Size

A ledge or TAND/loft in a habitable room shall not cover more than 25 percent of the area of the floor on which it is constructed and shall not interfere with the ventilation of the room under any circumstances.

12.6 Mezzanine Floor

12.6.1 Height

It shall have a minimum height of 2.2 m.

12.6.2 Size

The minimum size of the mezzanine floor, if it is to be used as a living room, shall not be less than 9.5 m². The aggregate area of such mezzanine floor in a building shall in no case exceed one-third the plinth area of the building.

12.6.3 Other Requirements

A mezzanine floor may be permitted over a room or a compartment provided:

- a) it conform to the standard of living rooms as regards lighting and ventilation in case the size of mezzanine floor is 9.5 m² or more (see 14.1.2);
- b) it is so constructed as not to interfere under any circumstances with the ventilation of the space over and under it;
- c) such mezzanine floor is not sub-divided into smaller compartments;
- d) such mezzanine floor or any part of it shall not be used as a kitchen; and
- e) in no case shall a mezzanine floor be closed so as to make it liable to be converted into unventilated compartments.

12.7 Store Room

12.7.1 Height

The height of a store room shall be not less than 2.2 m.

12.7.2 Size

The size of a store room, where provided in a residential building, shall be not less than 3 m².

12.8 Garage

12.8.1 Height

The height of a garage shall be not less than 2.4 m.

12.8.2 Size

The size of garages shall be as below:

- a) *Private Garage* — 3.0 m × 6.0 m, minimum; and
- b) *Public Garage* — Based on the number of vehicles parked, etc (see 10).

12.9 Basement

12.9.1 The basement shall not be used for residential purposes.

12.9.2 The construction of the basement shall be allowed by the Authority in accordance with the land use and other provisions specified under the Development Control Rules.

12.9.2.1 The basement to be constructed within the building envelope and subject to maximum coverage on floor 1 (entrance floor) may be put to only the following uses:

- a) Storage of household or other goods of ordinarily non-combustible material;
- b) Strong rooms, bank cellars, etc;
- c) Air-conditioning equipment and other machines used for services and utilities of the building; and
- d) Parking spaces.

12.9.3 The basement shall have the following requirements:

- a) Every basement shall be in every part at least 2.4 m in height from the floor to the underside of the roof slab or ceiling;
- b) Adequate ventilation shall be provided for the basement. The ventilation requirements shall be the same as required by the particular occupancy according to byelaws. Any deficiency may be met by providing adequate mechanical ventilation in the form of blowers, exhaust fans, air-conditioning systems, etc;
- c) The minimum height of the ceiling of any basement shall be 0.9 m and the maximum, 1.2 m above the average surrounding ground level;
- d) Adequate arrangements shall be made such that surface drainage does not enter the basement;
- e) The walls and floors of the basement shall be watertight and be so designed that the effects of the surrounding soil and moisture, if any, are taken into account in design and adequate damp proofing treatment is given; and
- f) The access to the basement shall be separate from the main and alternative staircase

providing access and exit from higher floors. Where the staircase is continuous in the case of buildings served by more than one staircase, the same shall be of enclosed type serving as a fire separation from the basement floor and higher floors. Open ramps shall be permitted if they are constructed within the building line subject to the provision of (d).

The exist requirements in basements shall comply with the provisions of Part 4 'Fire and Life Safety'.

12.10 Chimneys

The chimneys shall be built at least 0.9 m above flat roofs, provided the top of the chimneys is not below the top of the adjacent parapet wall. In the case of sloping roofs, the chimney top shall not be less than 0.6 m above the ridge of the roof in which the chimney penetrates.

12.11 Parapet

Parapet walls and handrails provided on the edges of roof terraces, balcony, *VARANDAH*, etc shall not be less than 1.0 m and not more than 1.2 m in height from the finished floor level.

12.12 Cabin

The size of cabins shall not be less than 3.0 m² with a minimum width of 1.0 m. The clear passages within the divided space of any floor shall not be less than 0.75 m and the distance from the farthest space in a cabin to any exit shall not be more than 18.5 m. In case the sub-divided cabin does not derive direct lighting and ventilation from any open spaces/mechanical means, the maximum height of the cabin shall be 2.2 m.

12.13 Boundary Wall

12.13.1 The requirements of the boundary wall are given below:

- a) Except with the special permission of the Authority, the maximum height of the compound wall shall be 1.5 m above the centre line of the front street. Compound wall up to 2.4 m height may be permitted if the top 0.9 m is of open type construction of a design to be approved by the Authority.
- b) In the case of a corner plot, the height of the boundary wall shall be restricted to 0.75 m for a length of 10 m on the front and side of the inter-sections and the balance height of 0.75 m if required in accordance with (a) may be made up of open type construction (through railings) and of design to be approved by the Authority.
- c) However, the provisions of (a) and (b) are not

applicable to boundary walls of jails. In industrial buildings, electric sub-stations, transformer stations, institutional buildings like sanatoria, hospitals, industrial buildings like workshops, factories and educational buildings like schools, colleges, including hostels, and other uses of public utility undertakings and strategically sensitive buildings, a height up to 2.4 m may be permitted by the Authority.

12.14 Wells

Wells, intended to supply water for human consumption or domestic purposes, where provided, shall comply with the requirements of **12.14.1** and **12.14.2**.

12.14.1 Location

The well shall be located:

- a) not less than 15 m from any ash pit, refuse pit, earth closet or privy and shall be located on a site upwards from the earth closet or privy;
- b) not less than 18 m from any cess pit soakway or borehole latrine and shall be located on a site upwards from the earth closet or privy;
- c) that contamination by the movement of sub-soil or other water is unlikely; and
- d) not under a tree or otherwise it should have a canopy over it, so that leaves and twigs may not fall into the well and rot.

12.14.2 Requirements

The well shall:

- a) have a minimum internal diameter of not less than 1 m;
- b) be constructed to a height not less than 1 m above the surrounding ground level, to form a parapet or kerb and to prevent surface water from flowing into a well, and shall be surrounded with a paving constructed of impervious material which shall extend for a distance of not less than 1.8 m in every direction from the parapet from the kerb forming the well head and the upper surface of such a paving shall be sloped away from the well;
- c) be of sound and permanent construction (*PUCCA*) throughout. Temporary or exposed (*KUTCHA*) wells shall be permitted only in fields or gardens for purposes of irrigation; and
- d) have the interior surface of the lining or walls of the well be rendered impervious for a depth of not less than 1.8 m measured from the level of the ground immediately adjoining the well-head.

12.15 Septic Tanks

Where a septic tank is used for sewage disposal, the location, design and construction of the septic tank shall conform to requirements of **12.15.1** and **12.15.2** [*see also Part 9 'Plumbing Services, Section 1 Water Supply, Drainage and Sanitation (Including Solid Waste Management)'*].

12.15.1 Location of the Septic Tanks and Subsurface Absorption Systems

A sub-soil dispersion system shall not be closer than 18 m from any source of drinking water, such as well, to mitigate the possibility of bacterial pollution of water supply. It shall also be as far removed from the nearest habitable building as economically feasible but not closer than 6 m, to avoid damage to the structures.

12.15.2 Requirements

- a) *Dimensions of septic tanks* — Septic tanks shall have a minimum width of 750 mm, a minimum depth of 1 m below the water level and a minimum liquid capacity of 1 m³. The length of tanks shall be 2 to 4 times the width;
- b) Septic tanks may be constructed of brickwork, stone masonry, concrete or other suitable materials as approved by the Authority;
- c) Under no circumstances shall effluent from a septic tank be allowed into an open channel drain or body of water without adequate treatment;
- d) The minimum nominal diameter of the pipe shall be 100 mm. Further, at junctions of pipes in manholes, direction of flow from a branch connection shall not make an angle exceeding 45° with the direction of flow in the main pipe;
- e) The gradients of land drains, under-drainage as well as the bottom of dispersion trenches and soakways shall be between 1:300 and 1:400;
- f) Every septic tank shall be provided with ventilating pipe of at least 50 mm diameter. The top of the pipe shall be provided with a suitable cage of mosquito-proof wire mesh. The ventilating pipe shall extend to a height which would cause no smell nuisance to any building in the area. Generally, the ventilating pipe may extend to a height of about 2 m, when the septic tank is at least 15 m away from the nearest building and to a height of 2 m above the top of the building when it is located closer than 15 m;
- g) When the disposal of septic tank effluent is to a seepage pit, the seepage pit may be of any suitable shape with the least cross-

sectional dimension of 0.90 m and not less than 1.00 m in depth below the invert level of the inlet pipe. The pit may be lined with stone, brick or concrete blocks with dry open joints which should be backed with at least 75 mm of clean coarse aggregate. The lining above the inlet level should be finished with mortar. In the case of pits of large dimensions, the top portion may be narrowed to reduce the size of the RCC cover slabs. Where no lining is used, specially near trees, the entire pit should be filled with loose stones. A masonry ring may be constructed at the top of the pit to prevent damage by flooding of the pit by surface runoff. The inlet pipe may be taken down a depth of 0.90 m from the top as an anti-mosquito measure; and

- h) When the disposal of the septic tank effluent is to a dispersion trench, the dispersion trench shall be 0.50 m to 1.00 m deep and 0.30 m to 1.00 m wide excavated to a slight gradient and shall be provided with 150 mm to 250 mm of washed gravel or crushed stones. Open jointed pipes placed inside the trench shall be made of unglazed earthenware clay or concrete and shall have a minimum internal diameter of 75 mm to 100 mm. Each dispersion trench shall not be longer than 30 m and trenches shall not be placed closer than 1.8 m.

12.16 Office-cum-Letter Box Room

In the case of multi-storeyed multi-family dwelling apartments constructed by existing and proposed Cooperative Housing Societies or Apartment Owners Associations, limited companies and proposed societies, an office-cum-letter box room of dimension 3.6 m × 3 m shall be provided on the ground floor. In case the number of flats is more than 20, the maximum size of the office-cum-letter box room shall be 20 m².

12.16.1 Business Buildings

Provision shall be made for letter boxes on the entrance floor as per the requirements of the postal department.

12.17 Meter Rooms

For all buildings above 15 m in height and in special occupancies, like educational, assembly, institutional, industrial, storage, hazardous and mixed occupancies with any of the aforesaid occupancies having area more than 500 m² on each floor, provision shall be made for an independent and ventilated meter (service) room, as per requirements of electric (service) supply undertakings on the ground floor with direct access from outside for the purpose of termination of electric

supply from the licensee's service and alternative supply cables. The door/doors provided for the service room shall have fire resistance of not less than two hours.

12.18 Staircase/Exit Requirements

12.18.1 The minimum clear width, minimum tread width and maximum riser of staircases for buildings shall be as given in **12.18.1.1** to **12.18.1.3** (*see also* Part 4 'Fire and Life Safety').

12.18.1.1 *Minimum width* — The minimum width of staircase shall be as follows:

- | | |
|---|-------|
| a) Residential buildings (dwellings) | 1.0 m |
| NOTE — For row housing with 2 storeys, the minimum width shall be 0.75 m. | |
| b) Residential hotel buildings | 1.5 m |
| c) Assembly buildings like auditoria, theatres and cinemas | 2.0 m |
| d) Educational building | 1.5 m |
| e) Institutional buildings | 2.0 m |
| f) All other buildings | 1.5 m |

12.18.1.2 *Minimum tread*

The minimum width of tread without nosing shall be 250 mm for residential buildings. The minimum width of tread for other buildings shall be 300 mm.

12.18.1.3 *Maximum riser*

The maximum height of riser shall be 190 mm for residential buildings and 150 mm for other buildings and these shall be limited to 12 per flight.

12.18.2 The minimum head-room in a passage under the landing of a staircase shall be 2.2 m. The minimum clear head-room in any staircase shall be 2.2 m.

12.18.3 *Exit Requirements*

All aspects of exit requirements for corridors, doors, stair cases, ramps, etc in respect of widths, travel distance shall be as per Part 4 'Fire and Life Safety'.

12.19 Roofs

12.19.1 The roof of a building shall be so designed and constructed as to effectively drain water by means of sufficient rain-water pipes of adequate size, wherever required, so arranged, jointed and fixed as to ensure that the rain-water is carried away from the building without causing dampness in any part of the walls, roof or foundations of the building or an adjacent building.

12.19.2 The Authority may require rain-water pipes to be connected to a drain or sewer to a covered channel formed beneath the public footpath to connect the rain-

water pipe to the road gutter or in any other approved manner.

12.19.3 Rain-water pipes shall be affixed to the outside of the external walls of the building or in recesses or chases cut or formed in such external walls or in such other manner as may be approved by the Authority.

12.19.4 It is desirable to conserve rain water using suitable rain water harvesting techniques including by roof water collection. In this context, reference may be made to Part 9 'Plumbing Services, Section 1 Water Supply, Drainage and Sanitation (Including Solid Waste Management)'.

12.20 Special Requirements of Low Income Housing

Special requirements of low income housing shall be as given in Annex C. For detailed information in this regard, reference may be made to the accepted standards [3(1)].

12.21 Special Requirements for Physically Challenged

Special requirements for planning of buildings and facilities keeping in view the needs of the physically challenged, applicable particularly to public buildings meant for their use, are given in Annex D.

12.22 Special Requirements for Cluster Planning for Housing

Special requirements for cluster planning for housing shall be as given in Annex E.

12.23 Special Requirements for Low Income Habitat Planning in Rural Areas

Special requirements for low income habitat planning in rural areas shall be as given in Annex F.

12.24 Special Requirements for Development Planning in Hilly Areas

Special requirements for development planning in hilly areas is given in Annex G.

13 FIRE AND LIFE SAFETY

For requirements regarding fire and life safety for different occupancies, reference shall be made to Part 4 'Fire and Life Safety'.

14 DESIGN AND CONSTRUCTION

For requirements regarding structural design, reference shall be made to Part 6 'Structural Design' and for construction (including safety) reference shall be made to Part 7 'Constructional Practices and Safety'.

15 LIGHTING AND VENTILATION

15.1 For requirements regarding lighting and

ventilation for different uses and occupancies, reference shall be made to Part 8 'Building Services, Section 1 Lighting and Ventilation'.

15.1.1 Lighting and Ventilation of Rooms

Rooms shall have, for the admission of light and air, one or more openings, such as windows and ventilators, opening directly to the external air or into an open VERANDAH.

15.1.2 Notwithstanding the area of openings obtained through **15.1**, the minimum aggregate area (*see* Notes 1 to 3) of such openings, excluding doors inclusive of frames, shall be not less than:

- a) one-tenth of the floor area for dry hot climate;
- b) one-sixth of the floor area for wet hot climate;
- c) one-eighth of the floor area for intermediate climate; and
- d) one-twelfth of the floor area for cold climate.

NOTES

1 If a window is partly fixed, the openable area shall be counted.

2 No portion of a room shall be assumed to be lighted, if it is more than 7.5 m away from the opening assumed for lighting that portion.

3 The area of openings as given in (a) to (d) above shall be increased by 25 percent in the case of a kitchen [*see* **12.3.3(d)**].

16 ELECTRICAL AND ALLIED INSTALLATIONS (INCLUDING LIGHTNING PROTECTION OF BUILDINGS)

For requirements regarding electrical installations in buildings including lightning protection of buildings, reference shall be made to Part 8 'Building Services, Section 2 Electrical and Allied Installations'.

17 AIR CONDITIONING, HEATING AND MECHANICAL VENTILATION

For requirements regarding design, construction and installation of air conditioning, heating and mechanical ventilation systems, reference shall be made to Part 8 'Building Services, Section 3 Air Conditioning, Heating and Mechanical Ventilation'.

18 ACOUSTICS, SOUND INSULATION AND NOISE CONTROL

For requirements regarding the desired noise levels and sound insulation in different occupancies, reference shall be made to Part 8 'Building Services, Section 4 Acoustics, Sound Insulation and Noise Control'.

19 HEAT INSULATION

For calculation of solar radiation on buildings and recommended limits of thermal transmittance of roofs and walls for different parts of the country and heat transmission losses due to different constructions, reference may be made to good practice [3(2)].

20 INSTALLATION OF LIFTS AND ESCALATORS

Provision for lifts shall be made for buildings 15 m or more in height. For requirements regarding planning, designing and installation, etc of lifts and escalators, reference shall be made to Part 8 'Building Services, Section 5 Installation of Lifts and Escalators'.

21 PLUMBING SERVICES AND SOLID WASTE MANAGEMENT

For requirements regarding water supply, drainage and sanitation (including solid waste management) and gas supply, reference shall be made to Part 9 'Plumbing Services'.

ANNEX A

(Clause 9.5.1)

CIVIL AVIATION REQUIREMENTS FOR CONSTRUCTION IN THE VICINITY OF AN AERODROME

A-0 GENERAL

A-0.1 For the purpose of this Annex, the following definitions shall apply.

A-0.1.1 Aerodrome Reference Point (ARP) — This is a designated point, which is established in the horizontal plane at or near the geometric centre of the landing area.

A-0.1.2 Approach Funnel — See Fig. 8.

A-0.1.3 Elevation or Reduced Level — The vertical distance of a point or a level, on or affixed to the surface of the earth, measured from the mean sea level.

A-0.1.4 Transitional Area — An area which is below a specified surface sloping upwards and outwards from the edge of the approach funnel and from a line originating at the end of the inner edge of each approach area, drawn parallel to the runway centre line in the direction of landing (see Fig. 8).

A-0.1.5 Runway Strip — See Fig. 8.

A-1 PROHIBITED AREA

A-1.1 No building or structure shall be constructed or erected, or no tree shall be planted, on any land within the limits specified in **A-1.2** and **A-1.3** in respect of the aerodromes listed in **A-3** and in respect of the aerodrome at Thiruvananthapuram.

A-1.2 For the Aerodromes (see A-3)

These requirements shall be applicable for the land enclosed in approach funnels of the runway with a maximum distance of 360 m measured from each runway and along the extended centre line of the runway. For the purpose of this clause, the requirements of approach funnel and an instrument runway shall be as given in **A-1.2.1** to **A-1.2.3**.

A-1.2.1 Approach funnel in the case of an instrument runway means the area in the shape of an isosceles trapezium having the longer parallel side 4 800 m long (2 400 m on either side of the extended centre line of the runway) and smaller parallel side 300 m long (150 m on either side of the extended centre line of the runway) where the smaller and longer parallel sides are placed at a distance of 60 m and 15 060 m, respectively, from the end of the runway and at right angles to the extended centre line.

A-1.2.2 In the case of a non-instrument runway, the

approach funnel means the area in the shape of an isosceles trapezium having the longer parallel side 1 800 m long (900 m on either side of the extended centre line of the runway) and smaller parallel side 180 m long (90 m on either side of the extended centre line of the runway), where the smaller and longer parallel sides are placed at a distance of 60 m and 6 540 m, respectively, from the end of the runway and at right angles to the extended centre line. Thereafter, the trapezium is followed by a contiguous rectangular area of that width for the remainder of the length up to a distance of 15 060 m from the end of the runway.

A-1.2.3 An instrument runway is a runway served by visual and non-visual aid or aids providing at least directional guidance adequate for a straight in approach and intended for the operation of aircraft using instrument approach procedures.

A-1.3 For the Aerodrome at Thiruvananthapuram

These requirements shall be applicable for the land enclosed in approach funnels of all runways with a maximum distance of 304.80 m, measured from each runway and along extended centre line of the runway, and the land enclosed in a belt of 30.48 m width outside the operational boundary of the aerodrome. For the purpose of this clause, the requirements of approach funnel and operational boundary shall be as given in **A-1.3.1** and **A-1.3.2**.

A-1.3.1 Approach funnel means the area in the shape of an isosceles trapezium having the longer parallel side of length 4 724.4 m (2 362.2 m on either side of the extended centre line of the runway) and smaller parallel side of 152.4 m (76.2 m on either side of the extended centre line of the runway) where the smaller and longer parallel sides are placed at a distance of 60.9 m and 15 301 m, respectively, from the end of the runway and at right angles to the extended centre line.

A-1.3.2 Operational boundary means an area enclosed between parallel lines at a distance of 152.4 m on either side of the centre line of the runways or 30.4 m from the boundary fencing of the aerodrome, whichever is greater.

A-2 HEIGHT RESTRICTION

A-2.1 For the Aerodromes (see A-3)

No building or structure higher than the height specified in Tables 5 and 6 shall be constructed or

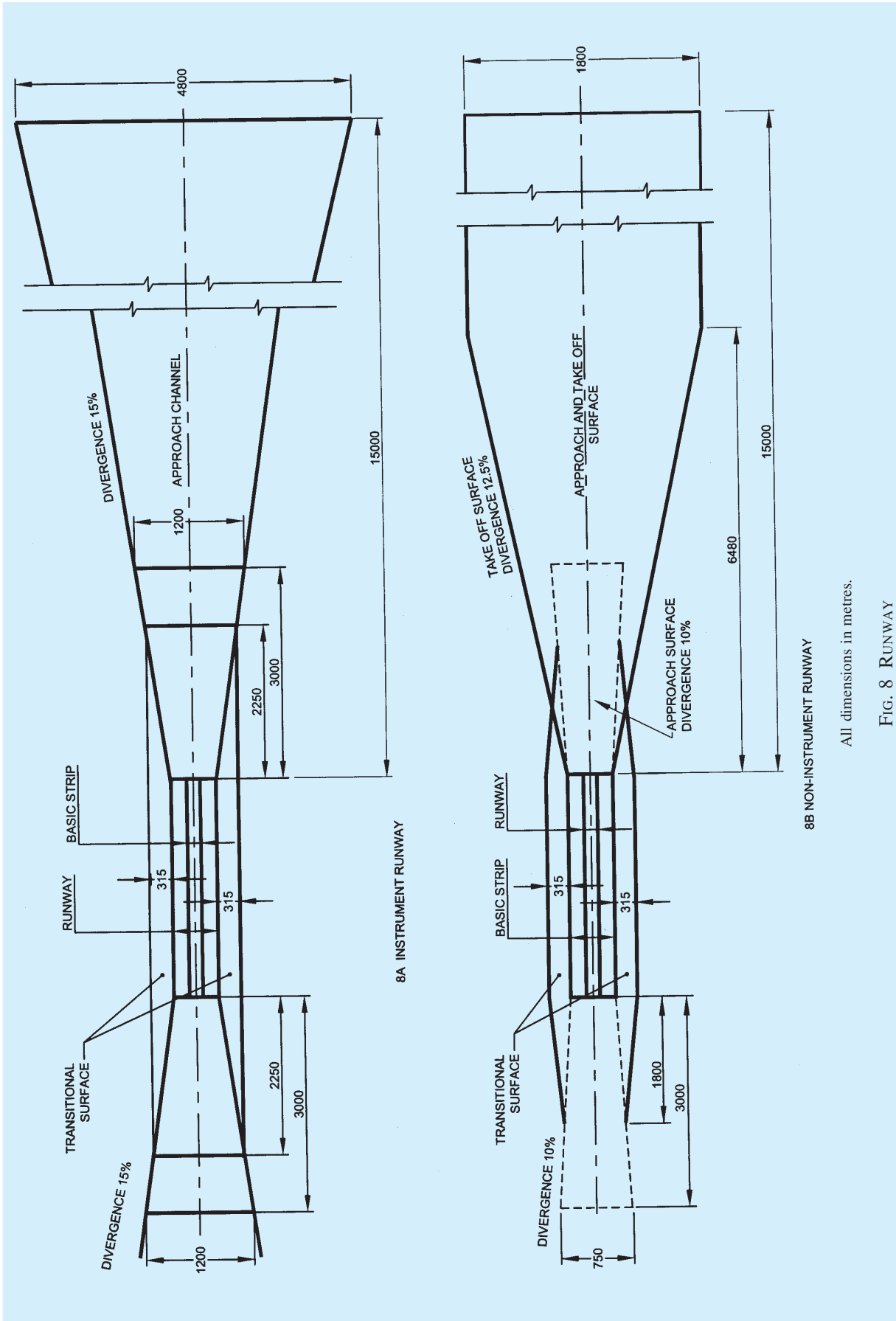

8B NON-INSTRUMENT RUNWAY

All dimensions in metres.

FIG. 8 RUNWAY

erected, or no tree which is likely to grow or ordinarily grows higher than the height specified in the Tables 5 and 6, shall be planted, on any land within a radius of 20 km from ARP of the aerodromes listed in A-3, excluding the land covered by A-1.2.

Table 5 Height Restriction with Respect to Approach Funnels
(Clauses A-2.1 and A-2.1.1)

Sl No.	Area	Maximum Permissible Height Above the Elevation of the Nearest Runway End
(1)	(2)	(3)
i)	More than 360 m but not exceeding 510 m	6
ii)	More than 510 m but not exceeding 660 m	9
iii)	More than 660 m but not exceeding 810 m	12
iv)	More than 810 m but not exceeding 960 m	15
v)	More than 960 m but not exceeding 1 110 m	18
vi)	More than 1 110 m but not exceeding 1 260 m	21
vii)	More than 1 260 m but not exceeding 1 410 m	24
viii)	More than 1 410 m but not exceeding 1 560 m	27
ix)	More than 1 560 m	30

A-2.1.1 Table 5 gives the height restriction with respect to approach funnels and shall be applicable for the land enclosed in the approach funnels of all runways where distances are measured from each end of the runway, along extended centre line of the runway.

A-2.1.2 Table 6 gives height restriction with respect to transitional area and shall be applicable for the land enclosed in the transitional area of all runways at an aerodrome listed in A-3 where distances are measured from the associated runway strip and the edge of the associated approach funnels, forming the inner boundary of the transitional area and along a line at right angles to the centre line of the runway.

A-2.2 For the Aerodrome at Thiruvananthapuram

No building or structure higher than the height specified in Table 7 shall be constructed or erected, or no tree which is likely to grow or ordinarily grows higher than the height specified in Table 7, shall be planted, on any level within a radius of 20 km from ARP of the aerodrome at Thiruvananthapuram, excluding the land covered by A-1.3.

Table 6 Height Restriction with Respect to Transitional Area
(Clauses A-2.1 and A-2.1.2)

Sl No.	Distance from the Inner Boundary of the Transitional Area Specified Above	Maximum Permissible Height Above the Elevation of the ARP
(1)	(2)	(3)
i)	Up to a distance of 21 m	—
ii)	More than 21 m but not exceeding 42 m	3
iii)	More than 42 m but not exceeding 63 m	6
iv)	More than 63 m but not exceeding 84 m	9
v)	More than 84 m but not exceeding 105 m	12
vi)	More than 105 m but not exceeding 126 m	15
vii)	More than 126 m but not exceeding 147 m	18
viii)	More than 147 m but not exceeding 168 m	21
ix)	More than 168 m but not exceeding 189 m	24
x)	More than 189 m but not exceeding 210 m	27
xi)	More than 210 m	30

Table 7 Height Restriction
(Clause A-2.2)

Sl No.	Area	Maximum Permissible Height Above Ground Level
(1)	(2)	(3)
i)	The area lying between the coastline and the Chakai canal other than specified in A-1.3	3
ii)	The area lying in a belt of 457.2 m width between the Eastern Bank of the Chakai canal and a line running parallel to this canal for the entire length	6
iii)	A parallel belt of 762 m width running East of area (ii) above	15.2
iv)	A parallel belt of 609.6 m width running East of area (iii) above	24.3
v)	Rest of the area extending up to 20 km from ARP	30.4

A-3 AERODROMES

A-3.1 A list of aerodromes indicating runway directions, runway elevations and ARP elevations is given in Table 8.

Table 8 Runway Directions, Runway End Elevations and ARP Elevations for Aerodromes
(Clause A-3.1)

Sl No.	Aerodrome	ARP Elevation m	Runway No.	Runway End Elevation
(1)	(2)	(3)	(4)	(5)
1.	Ahmadabad	55	14	54
			32	56
			05	54
			23	56
2.	Agartala	14	05	12
			23	14.5
			18	13.5
			36	13.5
3.	Akola	305	10	303
			28	303
4.	Amritsar	229	07	229
			25	230
			16	230
			34	229
5.	Aurangabad	581	09	582
			27	573.5
6.	Belgaum	758	08	755
			26	747
7.	Balurghat	24	09	24
			27	23
8.	Bangalore	888	09R	875
			27L	881
			09L	876
			27R	882.5
9.	Vadodara	37	04	36.5
			22	37.5
			09	36.5
			27	38.7
10.	Behala	2.6	18	3.5
			36	3.5
11.	Bhavnagar	5.4	07	11
			25	6
12.	Bhopal	523	06	522.5
			24	521
			12	521.5
			30	523
13.	Bhubaneshwar	44.5	05	33
			23	41.5
			14	38
			32	37
14.	Bhuj	78.5	05	81.5
			23	74.5
			11	79
			29	77.5
15.	Bilaspur	274	06	270
			24	282
			17	276
			35	269
16.	Chakulia	129	08	135
			26	132
			17	130
			38	27

Table 8 — Continued

(1)	(2)	(3)	(4)	(5)
17.	Chennai	10.5	07	12
			25	15.5
			12	9
			30	13
18.	Coimbatore	396	05	402
			23	391
19.	Cooch-Bihar	41.5	04	41.5
			22	41.5
20.	Delhi (Palam)	227	10	219
			28	236.5
			09	220
			27	229
21.	Delhi (Safdarjung)	212	12	215
			30	212
22.	Dibrugarh	109.5	05	109
			23	109.5
23.	Gauhati	48	03	49
			21	48
24.	Gaya	110	10	108
			28	115.5
			01	109
			19	111
25.	Hyderabad	531	09	530
			27	522
			14	531
			32	528
26.	Indore	561	07	563.5
			25	559.5
27.	Jabalpur	495	06	480
			24	494.5
28.	Jaipur	385	15	389.5
			33	384.4
			09	383.7
			27	381.3
29.	Jhansi	236	15	236.5
			33	236.5
30.	Jharsuguda	228	06	228.20
			24	229.14
31.	Kailashadar	27.5	03	28.5
			21	27.5
32.	Kamalpur	39	01	45
			19	41
33.	Kandla	29	05	29
			23	29
34.	Kanpur	125	10	125
			28	124.5
35.	Keshod	49.5	05	50.5
			23	50.5
			18	50
			36	52
36.	Khajuraho	217.4	01	222
			19	210
37.	Kolhapur	607	07	609.6
			25	605.6
38.	Kolkata	5.3	01L	4.8
			19R	5
			01R	5
			19L	4.5

Table 8 — Continued				
(1)	(2)	(3)	(4)	(5)
39.	Kota	273	08	272
			26	272
40.	Kulu	1084	16	1089
			34	1088
41.	Khowai	29	18	26
			36	27
42.	Lalitpur	367	10	368.5
			28	363
43.	Lilabari	100.2	04	101.5
			22	101.5
44.	Lucknow	122	09	122
			27	122
			01	122
			19	123
45.	Madurai	136.30	09	140
			27	130
			13	138.5
			31	136
46.	Malda	24	11	24
			29	23.5
47.	Mangalore	102	09	97
			27	89
48.	Mumbai (Juhu)	3	08	5
			26	2.5
			04	2.5
			22	2.5
			16	2.5
			34	2.5
49.	Mumbai (Santacruz)	8	09	4
			27	10
			14	11
			32	7.5
50.	Muzaffarpur	53	11	53
			29	53
51.	Mysore	715.5	05	720
			23	710
			09	717.5
			27	708
52.	Nagpur	308.5	09	309
			27	301
			14	315
			32	307
53.	Panagarh	73	15	71
			33	73
54.	Panna	425	17	435.80
			35	410.35
55.	Passighat	155.5	17	156.5
			35	153
56.	Patna	51	07	52
			25	52

Table 8 — Concluded				
(1)	(2)	(3)	(4)	(5)
57.	Pantnagar	233	10	234
			28	234
58.	Porbandar	5	09	6.7
			27	4.5
59.	Port Blair	6	04	3.66
			22	17.8
60.	Raipur	313.6	06	309
			24	316
61.	Rajahmundry	45	05	34
			23	46
62.	Rajkot	134	05	133
			23	128.5
			14	130
			32	133.5
63.	Ranchi	646	13	654
			31	632.5
64.	Satna	319	11	316.5
			29	316
65.	Sholapur	418	15	478.5
			33	478
66.	Silchar	102	06	98.5
			24	107.5
67.	Tanjore	76	14	77
			32	70.5
			07	76.5
			25	74.5
68.	Tiruchchirappalli	85	15	84
			33	85
			09	88
			27	84
69.	Tirupati	103	08	106.4
			26	102
70.	Tulihal (Imphal)	774.5	04	773.5
			22	775
71.	Udaipur	509	08	511.5
			26	508
72.	Varanasi	80	09	80
			27	80
73.	Vijayawada	21	08	25
			26	21.5
74.	Vishakhapatnam	3	05	4
			23	2
			09	4
			27	2
			18	4
			36	4
75.	Warangal	285	15	290
			33	276.5
			09	289
			27	280.5

ANNEX B

(Clause 10.1)

OFF-STREET PARKING SPACES

The off-street parking spaces shall be as given below:

Sl No.	Occupancy	One Car Parking Space for Every				
		Population less than 50 000	Population 50 000 to 200 000	Population Between 200 000 to 1 000 000	Population Between 1 000 000 to 5 000 000	Population Above 5 000 000
(1)	(2)	(3)	(4)	(5)	(6)	(7)
i)	Residential	—	—	a) 2 tenements having built-up area 101 to 200 m ²	1 tenement of 100 m ² built-up area	1 tenement of 75 m ² built-up area
	a) Multi-family	—	—	b) 1 tenement of 200 m ² built-up area		
	b) Lodging establishments, tourist homes and hotels, with lodging accommodation	12 guest rooms	8 guest rooms	4 guest rooms	3 guest rooms	2 guest rooms
ii)	Educational (see Note 1)	—	—	70 m ² area or fraction thereof of the administrative office area and public service areas	50 m ² area or fraction thereof of the administrative office area and public service areas	35 m ² area or fraction thereof of the administrative office area and public service areas
iii)	Institutional (Medical)	20 beds (Private) 30 beds (Public)	15 beds (Private) 25 beds (Public)	10 beds (Private) 15 beds (Public)	5 beds (Private) 10 beds (Public)	2 beds (Private) 5 beds (Public)
iv)	a) Assembly halls, cinema theatres	120 seats	80 seats	25 seats	15 seats	10 seats
	b) Restaurants	60 seats	40 seats	20 seats	10 seats	5 seats
	c) Marriage halls, community halls	600 m ² plot area	400 m ² plot area	200 m ² plot area	50 m ² plot area	25 m ² plot area
	d) Stadia and exhibition centre	240 seats	160 seats	50 seats	30 seats	20 seats
v)	a) Business offices and firms for private business	300 m ² area or fraction thereof	200 m ² area or fraction thereof	100 m ² area or fraction thereof	50 m ² area or fraction thereof	25 m ² area or fraction thereof
	b) Public or semi-public offices	500 m ² area or fraction thereof	300 m ² area or fraction thereof	200 m ² area or fraction thereof	100 m ² area or fraction thereof	50 m ² area or fraction thereof

(1)	(2)	(3)	(4)	(5)	(6)	(7)
vi)	Mercantile (see Note 2)	300 m ² area or fraction thereof	200 m ² area or fraction thereof	100 m ² area or fraction thereof	50 m ² area or fraction thereof	25 m ² area or fraction thereof
vii)	Industrial	400 m ² area or fraction thereof	300 m ² area or fraction thereof	200 m ² area or fraction thereof	100 m ² area or fraction thereof	50 m ² area or fraction thereof
viii)	Storage	—	—	500 m ² floor area or part thereof	250 m ² area or fraction thereof	125 m ² area or fraction thereof

NOTES

1 In the case of auditoria for educational buildings, parking space shall be provided as per SI No. (iv)

2 For plots up to 50 m², as in the case of shops, parking spaces need not be insisted upon.

3 For other institutions, transport/communication centre, parking space requirement shall be assessed based on the proposed building.

ANNEX C

(Clause 12.20)

SPECIAL REQUIREMENTS FOR LOW INCOME HOUSING IN URBAN AREAS

C-1 GENERAL

C-1.1 These guidelines cover the planning and general building requirements of low income housing for houses having a maximum plinth area of 40 m² including future expansion. The requirement regarding layout planning of low income housing colonies are applicable to public and private agencies/government bodies. The requirements on design and construction of buildings for low income housing in approved layouts are applicable to all private and public agencies.

C-1.2 In these planning standards, the general master plan requirement for community open spaces estimated at 0.3 ha for thousand persons is provided; road areas are worked out between 10 and 20 percent of the site area; one nursery school of 0.1 ha is provided for a population of 1 500 and shopping centres at 4 shops per thousand population are also covered.

C-1.3 It is emphasized that this type of development should apply to clusters of 400 dwelling units, so distributed in the development under consideration as to maintain the overall densities of the master plan for the area.

C-2 PLANNING

C-2.1 Type of Development

The type of development for low income housing shall be plotted developments as row housing/flatted development as row housing or group housing on cluster pattern.

C-2.2 Layout Pattern

C-2.2.1 In the land to be developed, at least 75 percent of the plots may be of the size less than or up to 60 m² per dwelling unit in metropolitan towns and 100 m² in other towns and hill areas. Remaining 25 percent of the plots may be more than 60 m², however, no plot shall be more than 200 m². In case of group housing or flatted development at least 75 percent units should have a plinth area (excluding external circulation such as stairs, lifts, lobbies, etc) up to or not exceeding 40 m² including future expansion.

C-2.2.2 The mix of plot of different sizes should have a wide range to accommodate the need of lower income group. The project may include more than one site provided they are in the same neighbourhood.

C-2.2.3 The layout should generally conform to the following land use:

	Land Under Each Use	
	General	Hill Area
<i>Saleable</i>		
i) Residential	50 percent, <i>Min</i>	35 percent
ii) Work places, schools, institutions, shops, community places, etc	20 percent, <i>Max</i>	15 percent
<i>Non-Saleable</i>		
Roads, pedestrian paths, drains, public and semi-public open spaces	30 percent, <i>Max</i>	50 percent

NOTES

1 Any neighbourhood development should have provision for

basic civic and community facilities, however, where such facilities are available in proximity the same could be considered and, in that case, the area under residential use could be increased correspondingly.

2 If land required under statutory provisions of master plan/development plan is proportionately higher but serves larger city needs, re-adjustment of the recommended land use pattern can be considered. Such provisions should, however, be carefully reviewed by the planning authorities to keep them to the barest minimum levels.

C-2.3 Plot Area

C-2.3.1 Plot Size

The minimum plot size with ground coverage not exceeding 75 percent, shall not be less than 40 m² in small and medium town and not less than 30 m² in metropolitan cities. Plot sizes below 30 m² but not less than 15 m² may be permitted in case of cluster planning, however, in such cases the ground coverage and FSI shall be 100 percent and 2 percent respectively (*see also* Annex E for Special requirements for cluster planning for housing).

NOTES

1 In exceptional cases in metropolitan cities with population more than 1 million the size of plots may be brought down to 25 m² in cases of low income housing colonies located in congested areas as decided by the Authority. In mega-cities it may be further reduced to 15 m². In such cases where plot size is below 25 m², only cluster planning or group housing may be adopted.

2 A minimum of 25 percent of the plot size shall be left open without adversely affecting light and ventilation for habitable spaces and toilet. It shall not be made mandatory to leave set back on any side.

C-2.3.2 Minimum Frontage

The minimum frontage of the plot shall be 3.6 m in width.

C-2.4 Density

The density norms for plotted development and mixed development shall be as follows:

<i>Type of Development</i>	<i>Range of Densities (Gross)</i>
a) Plotted development	65-120 plots per hectare
b) Mixed development	
i) Small towns	75-100 dwelling units per hectare
ii) Cities	100-125 dwelling units per hectare
iii) Metropolitan Cities	125-150 dwelling units per hectare

C-2.4.2 In case of developments with per dwelling unit covered area of 15 m² maximum densities of 500 dwelling units per hectare shall be permissible.

C-2.5 Height of Building

The height of building shall not exceed 15 m.

NOTES

1 For buildings up to the height of 15 m, there is no need to provide lifts.

2 Housing for the low-income group shall preferably be up to a maximum of two storeys.

3 Buildings for housing beyond 15 m in height should be resorted to in exceptional circumstances and it should be governed by provisions laid down in this Code.

C-2.6 Cluster Planning

For size of open cluster and open space, set backs, vehicular access and pedestrian paths in cluster planning, the provisions given in Annex E shall apply.

C-3 GENERAL BUILDING REQUIREMENTS

C-3.1 General

The requirements of parts of buildings shall be as given in C-3.2 to C-3.9.

C-3.2 Plinth

The minimum height of plinth shall be regulated on the basis of environmental and topographical condition and higher plinth height may be required in areas prone to flooding.

C-3.3 Size of Room

C-3.3.1 Habitable Room

Every dwelling unit to be provided should have at least two habitable rooms. Even if one room house is provided initially it should be capable of adding a new second room in future. However, in case single room tenements are required to be provided where future additions are not possible, the carpet area of multipurpose single room should be at least 12.5 m². Such one room dwelling units with 12.5 m² carpet area of habitable space is permitted only in case of on site rehabilitation of slum dwellers. In a house of two rooms, first room shall not be less than 9.0 m² with minimum width of 2.5 m and second room shall not be less than 6.5 m² with a minimum width of 2.1 m provided the total area of both the rooms is not less than 15.5 m². In incremental housing the bigger room shall always be the first room.

C-3.3.1.1 To facilitate incremental housing in case of flatted development or otherwise, habitable space at mezzanine level may be permitted. The minimum size of such a mezzanine floor should not be lesser than 6.5 m² and such a floor should occupy not more than 50 percent of the room area of which it is a part. Such a mezzanine floor should have appropriate openings to facilitate light and ventilation as per C-3.6. Minimum

clear height below and above the mezzanine floor should be 2.4 m and 2.1 m respectively.

As far as possible mezzanine floor should have direct ventilation from the external face of the building. Where this is not possible ventilation through main room may be allowed provided total area of openings in the main room is provided taking into consideration area of mezzanine floor.

Such mezzanine floor may be accessible through the main room by a ladder, whose minimum angle with vertical plane should be $22\frac{1}{2}^\circ$. Height of the riser should be less than 250 mm.

C-3.3.2 Water Closet/Bathroom

- 1) The size of independent water-closet shall be 0.90 m^2 with minimum width of 0.9 m;
- 2) The size of independent bathroom shall be 1.20 m^2 with a minimum width of 1.0 m; and
- 3) The size of combined bathroom and water-closet shall be 1.80 m^2 with minimum width of 1.0 m.

C-3.3.3 Kitchen

The size of a cooking alcove serving as cooking space shall not be less than 2.4 m^2 with a minimum width of 1.2 m. The size of individual kitchen provided in a two-roomed house shall not be less than 3.3 m^2 with a minimum width of 1.5 m.

C-3.3.4 Balcony

The minimum width of individual balcony, where provided, shall be 0.9 m and shall not be more than 1.2 m and it shall not project beyond the plot line and on roads or pathway.

C-3.4 Basement

No basement floor shall be allowed.

C-3.5 Minimum Height

The minimum height of rooms/spaces shall be as follows:

- | | |
|----------------------|-------|
| a) Habitable room | 2.6 m |
| b) Kitchen | 2.6 m |
| c) Bath/water-closet | 2.1 m |
| d) Corridor | 2.1 m |

C-3.5.1 In the case of sloping roofs, the average height of roof for habitable rooms shall be 2.6 m and the minimum height at eaves shall be 2.0 m.

C-3.6 Lighting and Ventilation

The openings through windows, ventilators and other openings for lighting and ventilation shall be in accordance with **15.1.2**.

NOTE — The windows and other openings shall abut onto open spaces either through areas left open within the plot or the front, side and rear spaces provided in the layouts which shall be deemed to be sufficient for light and ventilation purposes. Wherever ventilation/lighting is provided by means of *JALI* or grill of any material, total area of openings shall be calculated excluding solid portion of the *JALI* or grill.

C-3.7 Stairs

The following criteria shall be adopted for internal individual staircase:

-
- | | |
|---|----------------------------------|
| a) <i>Minimum Width</i> | |
| 1) 2 storeyed — straight | 0.60 m |
| 2) 2 storeyed — winding | 0.75 m |
| 3) 3 or more storeyed — straight | 0.75 m |
| 4) 3 or more storeyed — winding | 0.90 m |
| b) <i>Riser</i> | 200 mm, <i>Max</i> |
| c) <i>Tread</i> | |
| 1) 2 storeyed | 225 mm, <i>Min</i>
(see Note) |
| 2) 3 storeyed or more | 250 mm, <i>Min</i> |
| d) <i>Head Room</i> — The minimum clear head room shall be 2.1 m. | |

NOTE — This could be reduced to 200 mm as the clear tread between perpend, with possibility of open riser as well as nosing and inclined riser to have an effective tread of 225 mm.

C-3.8 Circulation Area

The circulation area on any floor including staircase, shall not exceed 8 m^2 /dwelling unit.

C-3.9 Water Seal Latrine

No building plan shall be approved and no building shall be deemed to have been completed and fit for human occupation unless provision is made for water seal latrine. No dry latrine shall be allowed. Water seal latrines can also be provide on the basis of community toilets or shared toilets as per the recommendation given in good practice [3(3)].

Where leaching pits are used, it should be constructed within the premises of the households as it would be economical as well as facilitate their cleaning. However, where, due to space constraint, construction of pits within the premises may not be possible, pits may be constructed in places like lanes, streets and roads.

In case the pit is located under the road, street or foot path, the inverted level of the pipe connecting the latrine pan with the pit shall be at least 1.1 m below ground level or below the bottom of the water main existing within a distance of 3 m from the pits whichever is more. Construction of such pits may be in accordance with good practice [3(4)].

The water seal latrine should be properly maintained and kept in sanitary condition by the owner or the occupier. The contents of the septic tanks, soak pits, leach pits, etc should be periodically emptied.

The leach pits should be cleaned only after 2 years of their being put out of service after they were full.

C-4 ROADS AND PATHWAYS

The area under roads and pathways in such housing projects should normally not exceed 20 percent of the total land area of the project.

Access to the dwelling units, particularly where motorized vehicles are not normally expected should be by means of paved footpaths with a right of way of 6 m and a pathway of 2 m only. The right of way should be adequate to allow for the plying of emergency vehicles and also for road side drains and plantation.

Where pedestrian pathways are not meant for motorable access to the minimum, right of way of such pedestrian pathway shall be 3 m. Where houses are accessible from one side only pathway can be 2 m wide. The maximum length of such pathways should not be more than 60 m.

C-5 OTHER REQUIREMENTS

C-5.1 Requirements of fire safety, structural design, building services and plumbing services shall be as specified in the Code.

C-5.2 One water tap per dwelling unit may be provided, where adequate drinking water supply is available. If supply is inadequate, public hydrants shall

be provided. In the absence of piped water supply, *hand pumps may be used for provision of water supply.*

C-5.3 Recognising the need for informal use of space for shopping and informal occupation like road side repairs, pan shops, etc, it is suggested that about ¼ of the total shopping area in a layout should be reserved for such informal uses to cater to the needs of low income families.

C-5.4 The infrastructural services shall be provided before the plots are handed over to individual owners.

C-6 SITE AND SERVICES SCHEMES

C-6.1 The developed plot sizes shall be as per **C-2.3.1**. Services would have to be laid by the Agency concerned as per the provisions of the Code. In so far as roads and pathways are concerned, they could also be in line with **C-4**.

C-6.2 Site and services schemes shall provide for the following.

- a) Complete infrastructural needs for a permanent housing, on the periphery of individual plot or a group/cluster plots;
- b) A service sanitary core in the plot;
- c) A skeletal structure of columns and roof or a developed plinth; and
- d) Permission to allow temporary construction on the plot.

While provisions in **C-6.2(a)** and **C-6.2(d)** are essential in site and services projects provisions, recommendations in **C-6.2(b)** and **C-6.2(c)** are additional provisions depending upon affordability.

ANNEX D

(Clause 12.21)

SPECIAL REQUIREMENTS FOR PLANNING OF PUBLIC BUILDINGS MEANT FOR USE OF PHYSICALLY CHALLENGED

D-1 GENERAL

D-1.1 These requirements apply to all buildings and facilities used by the public. These apply to temporary or emergency conditions as well as permanent conditions. It does not apply to private residences.

These requirements are concerned with non-ambulatory disabilities, semi-ambulatory disabilities, sight disabilities, hearing disabilities, disabilities of inco-ordination, aging, allergies, heart and lung diseases, epilepsy, haemophilia, incontinence and enterostomy.

It is intended to make all buildings and facilities used by

the public accessible to, and functional for the physically challenged through and within their doors, without loss of function, space or facility where the general public is concerned. It supplements the general requirements of the Code, and reflects greater concern for safety of life and limb. In cases of practical difficulty, unnecessary hardship, or extreme differences, the Authority may grant exceptions from the literal requirements of this Annex or permit the use of other methods or materials, but only when it is clearly evident that equivalent facilities and protection are thereby secured.

D-1.2 For the purpose of this Annex, the following definitions shall apply.

D-1.2.1 Aging

Those manifestations of the aging processes that significantly reduce mobility, flexibility, co-ordination, and perceptiveness but are not accounted for in the categories mentioned in **D-1.2.3.1** to **D-1.2.3.9**.

D-1.2.2 Appropriate Number

The number of a specific item that would be necessary, in accordance with the purpose and function of building or facility, to accommodate individuals with specific disabilities in proportion to the anticipated number or individuals with disabilities who would use a particular building or facility.

D-1.2.3 Disabilities

D-1.2.3.1 Non-ambulatory disabilities

Impairments that, regardless of cause or manifestation, for all practical purposes, confine individuals to wheelchairs.

D-1.2.3.2 Semi-ambulatory disabilities

Impairments that cause individuals to walk with difficulty or insecurity. Individuals using braces or crutches, amputees, arthritis, spastics and those with pulmonary and cardiac ills may be semi-ambulatory.

D-1.2.3.3 Sight disabilities

Total blindness or impairments affecting sight to the extent that the individual functioning in public areas is insecure or exposed to danger.

D-1.2.3.4 Hearing disabilities

Deafness or hearing handicaps that might make an individual insecure in public areas because he is unable to communicate or hear warning signals.

D-1.2.3.5 Disabilities of inco-ordination

Faulty co-ordination or palsy from brain spinal, or peripheral nerve injury.

D-1.2.3.6 People with allergies

People with allergies may be sensitive to dust, mildew, pollen, animal hair, formalin, turpentine, etc. Some are sensitive to contact with substances and materials, such as, nickel, chromium and rubber.

D-1.2.3.7 People with heart and lung diseases

People with heart and lung diseases may only be able to walk short distances and may be unable to climb stairs. The requirements of these people are similar to those with impaired mobility.

D-1.2.3.8 People with epilepsy, haemophilia, etc

The requirements of those with epilepsy, haemophilia, etc, are related primarily to the design of buildings and the need to minimize the risk of injury caused by falling or encountering obstacles.

D-1.2.3.9 People with incontinence, enterostomy operations, etc

The requirements of people with incontinence, enterostomy operations, etc (colostomies, ileostomies and urostomies) are mainly related to bathroom provision. In certain circumstances, for example, in public water-closet compartments, it may be desirable to provide a special sink for emptying urine bags.

D-1.2.4 Fixed Turning Radius, Front Structure to Rear Structure

The turning radius of a wheelchair, left front-foot platform to right rear wheel, or right front-foot platform to left rear wheel, when pivoting on a spot.

D-1.2.5 Fixed Turning Radius Wheel

The tracking of the caster wheels and large wheels of a wheelchair when pivoting on a spot.

D-1.2.6 Involved (Involvement)

A portion or portions of the human anatomy or physiology, or both, that have a loss or impairment of normal function as a result of genesis, trauma, disease, inflammation or degeneration.

D-1.2.7 Ramps, Ramps with Gradients

Because the term 'ramp' has a multitude of meanings and uses, its use in this text is clearly defined as ramps with gradients (gradual slope joining two level surfaces) that deviate from what would otherwise be considered the normal level. An exterior ramp, as distinguished from a 'walk', would be considered an appendage to a building leading to a level above or below the existing ground level.

D-1.2.8 Walk, Walks

Because the terms 'walk' and 'walks' have a multitude of meanings and uses, their use in this standard is clearly defined as a predetermined prepared surface, exterior pathway leading to or from a building or facility, or from one exterior area to another, placed on the existing ground level and not deviating from the level of the existing ground immediately adjacent.

D-2 SITE DEVELOPMENT

D-2.1 Almost any building can be made accessible to physically challenged persons by so planning the site that the terraces, retaining walls and winding walks are used effectively.

D-2.1.1 Site development is the most effective means to resolve the problems created by topography, definitive architectural designs or concepts, water table, existing streets, and typical problems, singularly or collectively, so that ingress, egress and access to buildings by physically challenged may be facilitated while preserving the desired design and effect of the architecture.

D-2.2 Walks

D-2.2.1 Public walks should be at least 1 200 mm wide and should have a gradient not greater than 1 in 20.

D-2.2.1.1 It is essential that the gradient of walks and driveways be less than that prescribed for ramps, since walks would be devoid of handrails and kerbs and would be considerably longer and more vulnerable to the elements. Walks of near maximum grade and considerable length should have level areas at intervals for purposes of rest and safety. Walks or driveways should have a non-slip surface.

D-2.2.2 Such walks shall be of a continuing common surface not interrupted by steps or abrupt changes in level.

D-2.2.3 Wherever walks cross other walks, driveways, or parking lots they should blend to a common level.

D-2.2.3.1 This requirement, does not require the elimination of kerbs, which, particularly if they occur at regular intersections, are a distinct safety feature for all of the challenged, particularly the blind. The preferred method of meeting the requirement is to have the walk incline to the level of the street. However, at principal intersections, it is vitally important that the kerbs run parallel to the street, up to the point where the walk is inclined, at which point the kerb would turn in and gradually meet the level of the walk at its highest point. A less preferred method would be to gradually bring the surface of the driveway or street to the level of the walk. The disadvantage of this method is that a blind person would not know when he has left the protection of a walk and has entered the hazards of a street or driveway (*see* Fig. 9).

D-2.2.4 A walk shall have a level platform at the top which is at least 1 500 mm long, if a door swings out onto the platform or towards the walk. This platform

shall extend at least 300 mm beyond each side of the doorway.

D-2.2.5 A walk shall have a level platform at least 900 mm deep, if the door does not swing onto the platform or towards the walk. This platform shall extend at least 300 mm beyond each side of the doorway.

D-2.3 Parking Space

D-2.3.1 Spaces that are accessible and approximate to the facility should be set aside and identified for use by individuals with physical disabilities.

D-2.3.2 A parking space open on one side, allowing room for individuals in wheelchairs or individuals on braces and crutches to get in and out of an automobile onto a level surface, is adequate. It should have a minimum width of 2 700 mm preferably 2 800 mm for ambulant disabled and minimum 3 000 mm preferably 3 300 mm for wheel chair users.

D-2.3.3 Parking spaces for individuals with physical disabilities when placed between two conventional diagonal or head-on parking spaces should be 3.6 m to 3.8 m wide and the length of the aisle should 7.3 m, 6.1 m and 6.5 m for head-on, 90° and 60° parking respectively.

D-2.3.4 Care in planning should be exercised, so that individuals in wheelchairs and individuals using braces and crutches are not compelled to wheel or walk behind parked cars.

D-2.3.5 Consideration should be given to the distribution of spaces for use by the disabled in accordance with the frequency and persistency of parking needs.

D-2.3.6 Walks shall be in conformity with D-2.2.

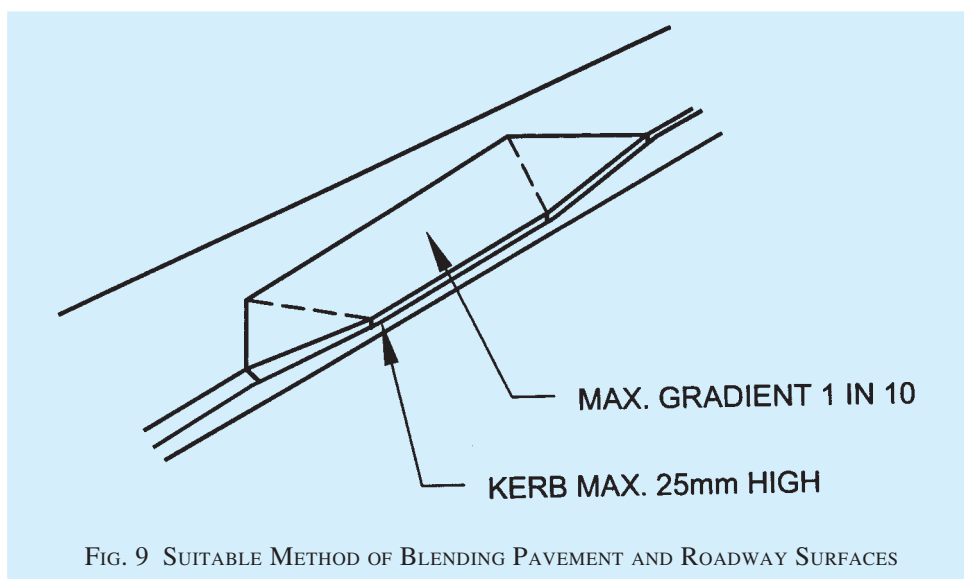

FIG. 9 SUITABLE METHOD OF BLENDING PAVEMENT AND ROADWAY SURFACES

D-3 BUILDINGS

D-3.1 Ramps with Gradients

Where ramps with gradients are necessary or desired, they shall conform to the following requirements (*see* Fig. 10).

D-3.1.1 A ramp when provided should not have a slope greater than 1 in 20 or maximum of 1 in 12 for short distance up to 9 000 mm.

D-3.1.2 A ramp shall have handrails on at least one side, and preferably two sides, that are 900 mm high, measured from the surface of the ramp, that are smooth, and that extend 300 mm beyond the top and bottom of the ramp. Where major traffic is predominantly children, the handrails should be placed 760 mm high.

NOTES

1 Where handrails are specified to be of heights other than 80 cm, it is recommended that two sets of handrails be installed to serve all people. Where major traffic is predominantly children, particularly physically disabled children, extra care should be exercised in the placement of handrails, in accordance with the nature of the facility and the age group or groups being serviced (*see also* D-3).

2 Care should be taken that the extension of the handrails is not in itself a hazard. Extension up to 300 mm may be made on the side of a continuing wall.

D-3.1.3 A ramp shall have a surface that is non-slip surface and if length is 3 500 mm, the minimum width shall be 1 500 mm.

D-3.1.3.1 The provision of non-slip surfaces on ramps

greatly assists the challenged persons with semi-ambulatory and ambulatory disabilities. Non-slip surfaces are provided by many finishes and materials. The surfaces of the concrete ramps can be made non-skid by brooming the surface or by finishing with an indenting roller.

D-3.1.4 A ramp shall have a level platform at the top which is at least 1 800 mm long, if a door swings out onto the platform or toward the ramp. This platform shall extend at least 300 mm beyond each side of the doorway (*see* Fig. 11).

D-3.1.5 Each ramp shall have at least 1 800 mm of straight clearance at the bottom.

D-3.1.6 Ramps shall have level platforms at 10 m to 12 m intervals for purposes of rest and safety, and shall have platforms minimum 1.5 m length wherever they turn.

D-3.1.7 For visually impaired people, ramps may be colour contrasted with landing.

D-3.1.8 To minimize rise to wheelchair users, ramps should be equipped with kerbs approximately 50 mm high at exposed sides.

D-3.2 Entrances

D-3.2.1 At least one primary entrance to each building shall be usable by individuals in wheelchairs (*see* Fig. 12A) and shall be indicated by a sign (*see* Fig. 12B).

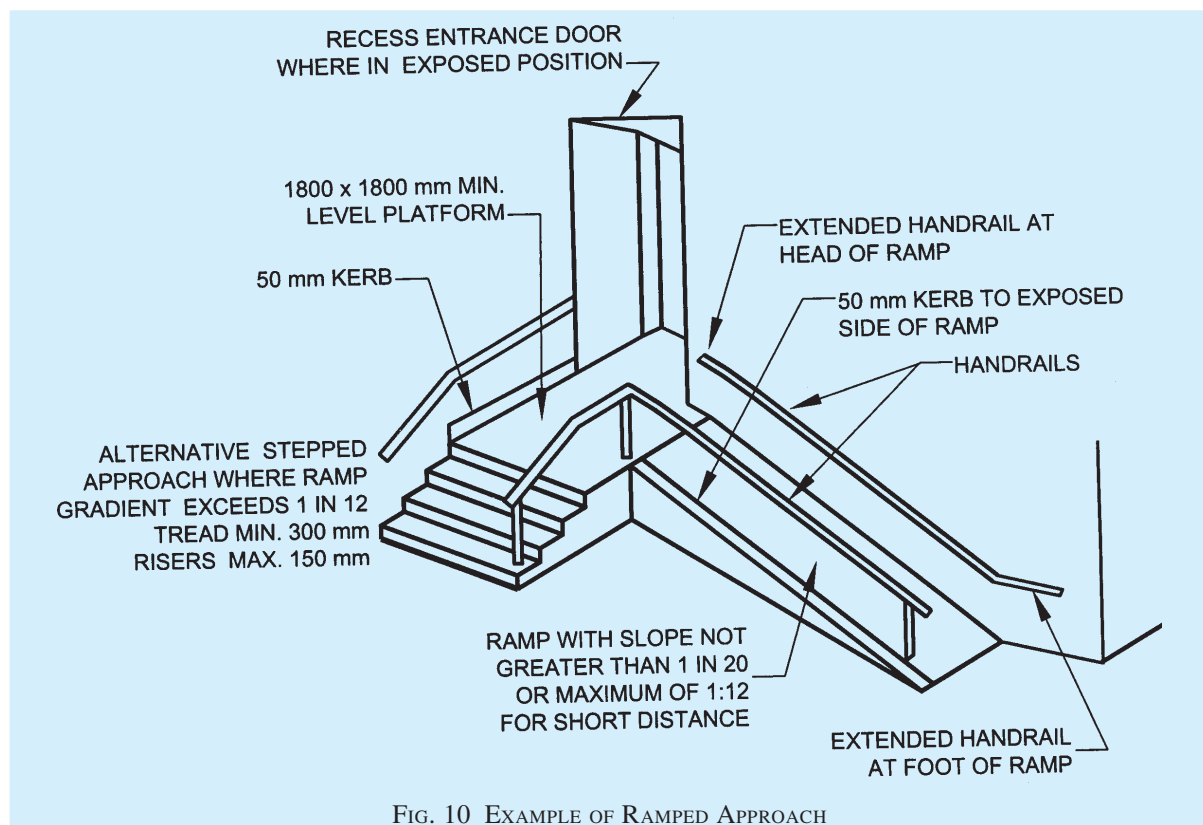

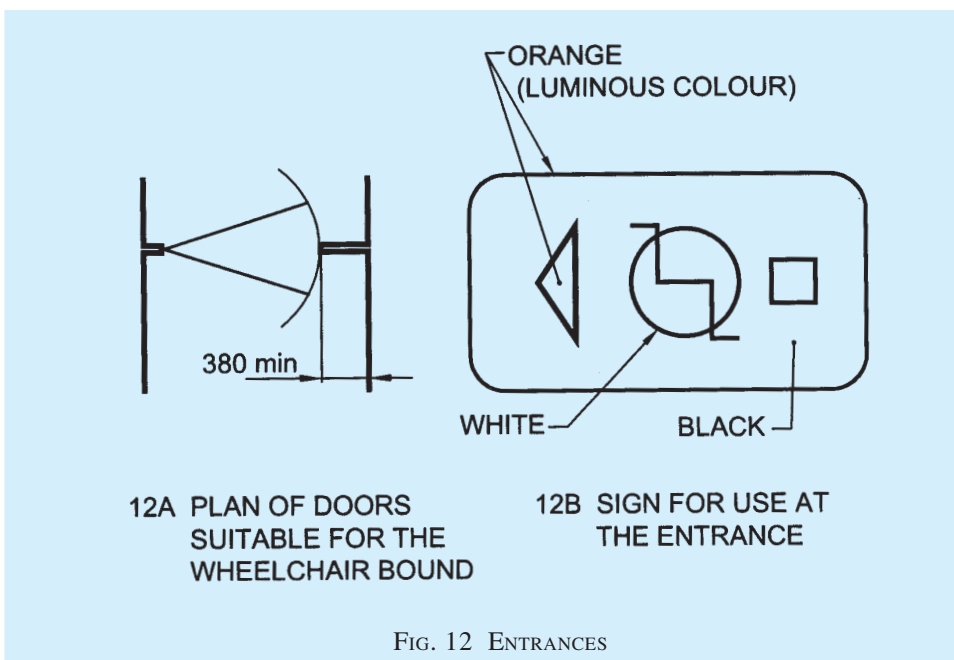
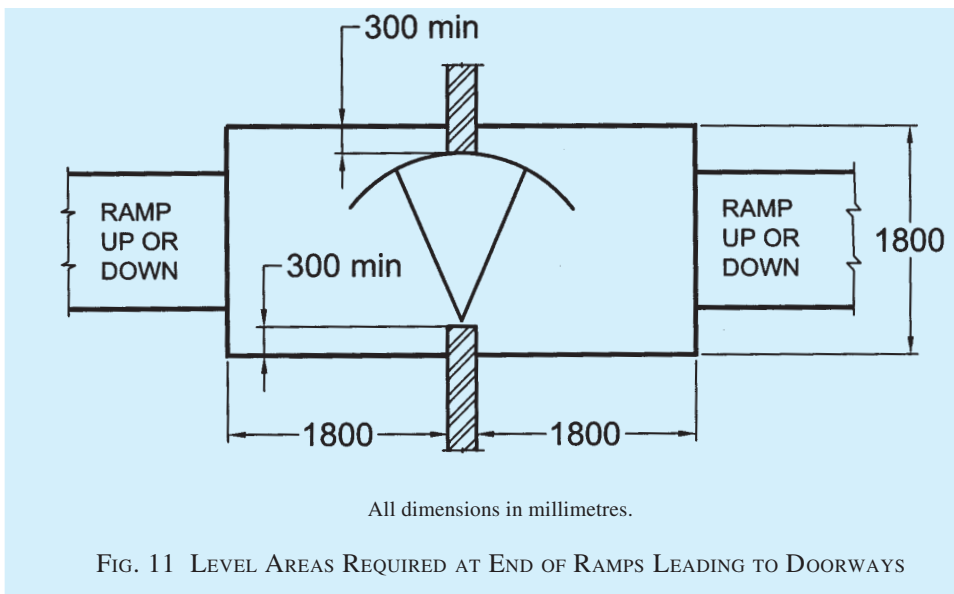

D-3.2.2 At least one entrance usable by individuals in wheelchairs shall be on a level that would make the elevators accessible.

D-3.3 Doors and Doorways

D-3.3.1 Doorwidth

To enable wheelchair users to pass through doors, the minimum clear width should be 900 mm and shall be operable by a single effort. In certain cases the clear width should be 900 mm to 1 000 mm; for example, if the wheelchair has to be turned in the doorway, where there is a door-closer or at entrance doors to public buildings and in other situations where there is considerable traffic.

D-3.3.1.1 Two-leaf doors are not usable by those with disabilities defined in **D-1.2.1**, **D-1.2.2** and **D-1.2.5** unless they operate by a single effort, or unless one of the two leaves meets the requirements of **D-3.3.1**.

D-3.3.1.2 Side-hung doors

To facilitate wheelchair manoeuvre, doors should be hung with the hinges in room corners. Doors opening out into corridors or circulation spaces should be avoided as far as possible.

D-3.3.1.3 It is recommended that all doors have kick plates extending from the bottom of the door to at least 400 mm from the floor, or be made of a material and finish that would safely withstand the abuse they might

receive from canes, crutches, wheelchair foot-
platforms, or wheelchair wheels.

D-3.3.2 Wheelchair Manoeuvring Space

To enable wheelchair users to approach doors manoeuvring space is needed as shown in the Fig. 13. A corridor should have a width of at least 1 200 mm to allow a 90° turn to be made through a door. In narrow spaces sliding doors may be preferable.

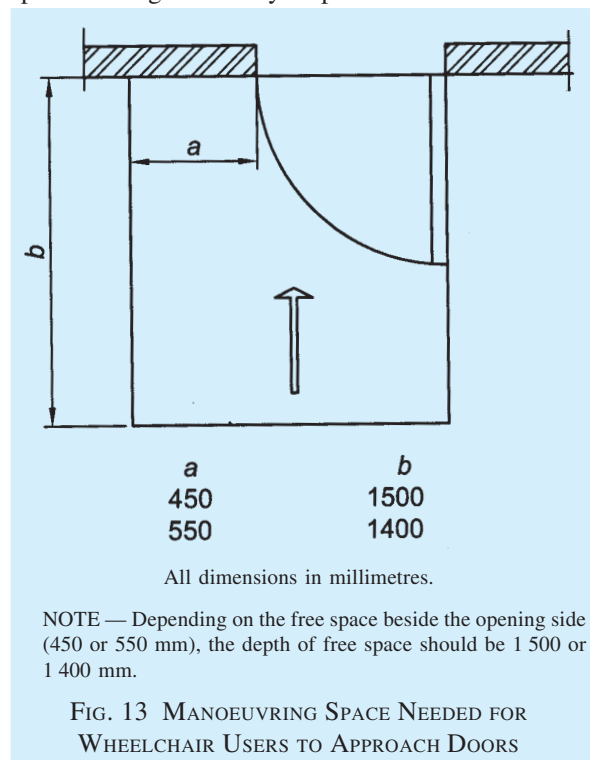

D-3.3.3 Thresholds

Raised thresholds should be avoided, but where this is not possible, their height should not exceed 25 mm. Rubber thresholds are advantageous for wheelchair users.

D-3.3.3.1 Care should be taken in the selection, placement and setting of door closers so that they do not prevent the use of doors by the physically disabled. Time-delay door closers are recommended.

D-3.3.3.2 Self-closing doors

Wheelchair users and other with impaired mobility have difficulty in using self-closing doors. The force required to open them should be reduced as far as possible. Public buildings should preferably have sliding automatic doors.

D-3.3.4 Door Identification

To help people with impaired vision to see doors, the door and frame should be in a colour which contrasts with the adjoining wall. Glass or glazed doors should

be marked with a coloured band or frame, a little below eye-level.

D-3.3.5 Handles

Door handles and locks should be easy to manipulate. To facilitate the closing of a door by wheelchair users (for example, a water-closet compartment), the door should have a horizontal handle approximately 800 mm from the floor. Self-closing doors should be equipped with an easy gripped vertical pull-handle with a length of at least 300 mm, and with the lower end approximately 800 mm above floor. For many people and specially those with impaired vision, it is helpful to make clear whether doors are to be pulled or pushed (see Fig. 14).

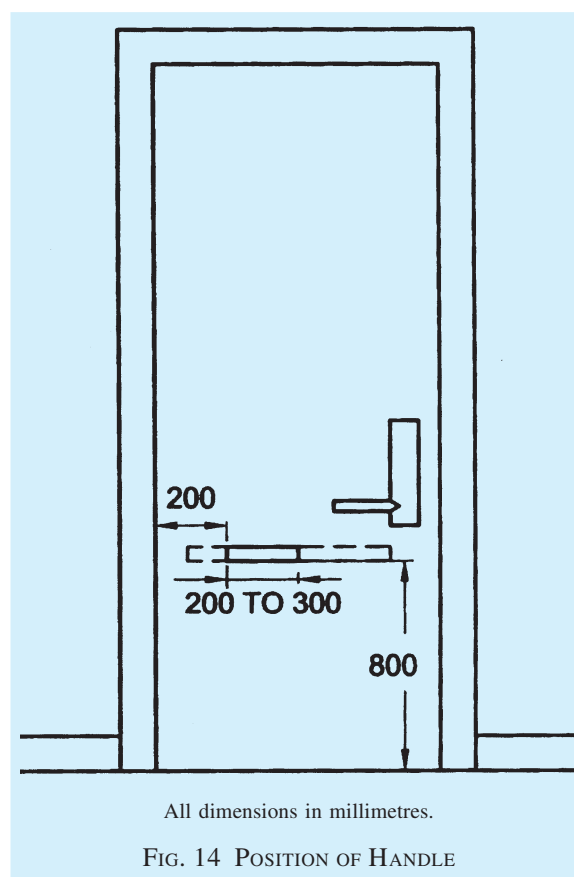

D-3.4 Windows

Windows should be designed to avoid the glare which is a particular problem for people with impaired vision. Large glass areas close to circulation spaces should be marked a little below eye-level with a coloured band or frame. To enable wheelchair users to see through a window comfortably, the sill should be not higher than 800 mm from the floor. Windows should be easy to open and close. Their controls should be placed in the zone 900 to 1 200 mm from the floor (see Fig. 15).

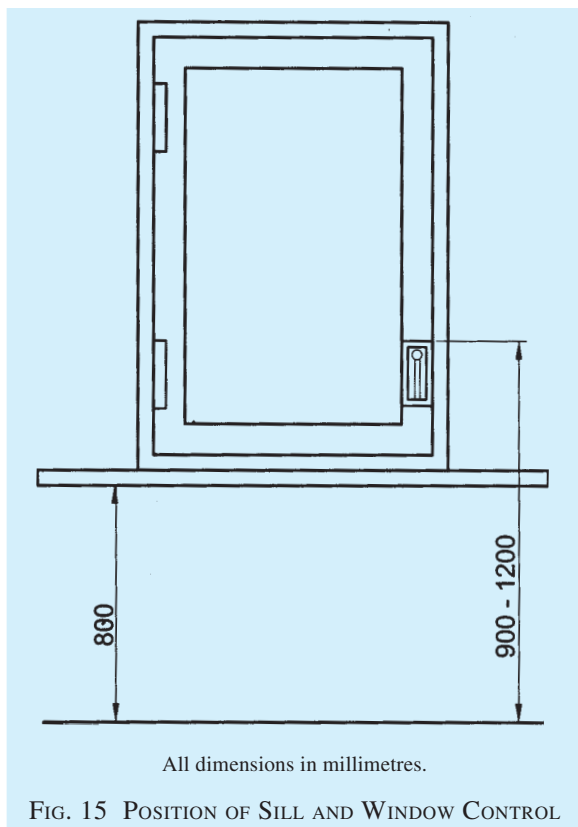

FIG. 15 POSITION OF SILL AND WINDOW CONTROL

D-3.5 Stairs

Stairs should not be the only means of moving between floors. They should be supplemented by lifts or ramps.

D-3.5.1 Straight flights of steps are preferred by ambulant disabled people. Treads should be approximately 300 mm deep and risers not higher than 150 mm. Steps should be of a consistent height and depth throughout the stair. Projecting nosings and open

stairs should be avoided to minimize the risk of stumbling.

D-3.5.2 Handrails should be provided to both sides of any stairway. They should be continuous and extend not less than 300 mm beyond the top and bottom step (otherwise it is difficult for the disabled to use the rail at the first and last step; *see* Fig. 16).

D-3.5.3 For people with impaired vision, there should be a colour contrast between landings, and top and bottom steps of a flight of steps, or the front edge of each step should have a contrasting colour.

D-3.6 Floors

D-3.6.1 Floors shall have a non-slip surface.

D-3.6.2 Floors on a given storey shall be of a common level through out or be connected by a ramp in accordance with **D-3.1.1** to **D-3.1.8**.

D-3.6.2.1 A gentle slope up to 10 mm may be given between the level of the floor of the corridor and the level of the floor of the toilet rooms.

D-3.6.2.2 There should not be a difference between the level of the floor of a corridor and the level of a meeting room, dining room, or any other room, unless proper ramps are provided.

D-3.7 Sanitary Facilities

It is essential that sanitary facilities, in accordance with the nature and use of a specific building or facility, be made accessible to, and usable by, the physically challenged.

D-3.7.1 Sanitary facilities shall have space to allow traffic of individuals in wheelchairs (*see* Fig. 17 and 18).

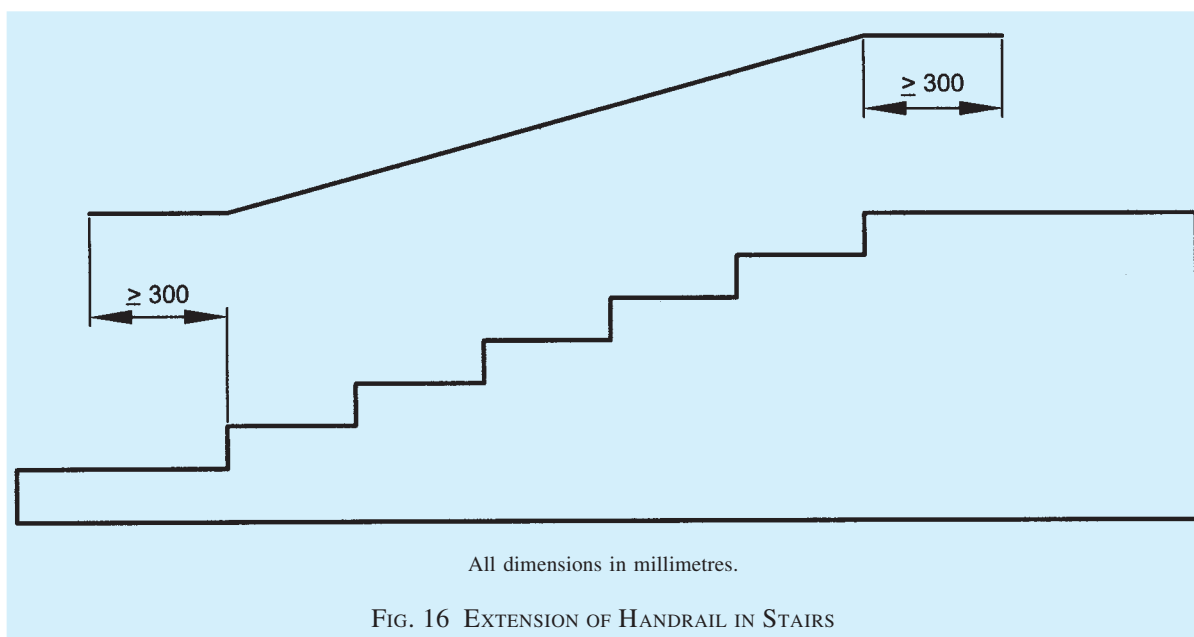

FIG. 16 EXTENSION OF HANDRAIL IN STAIRS

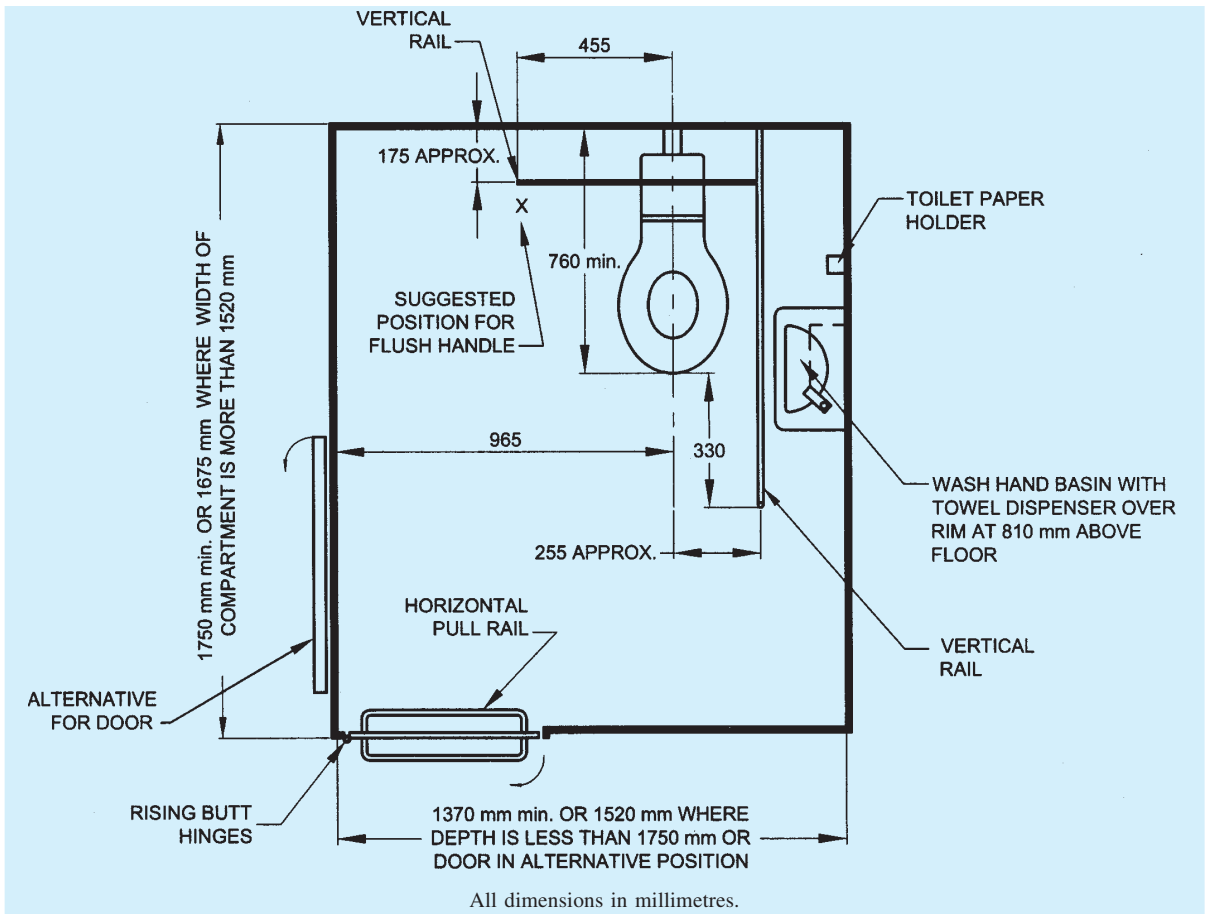

FIG. 17 SUGGESTED PLAN OF WC COMPARTMENT FOR THE WHEELCHAIR BOUND

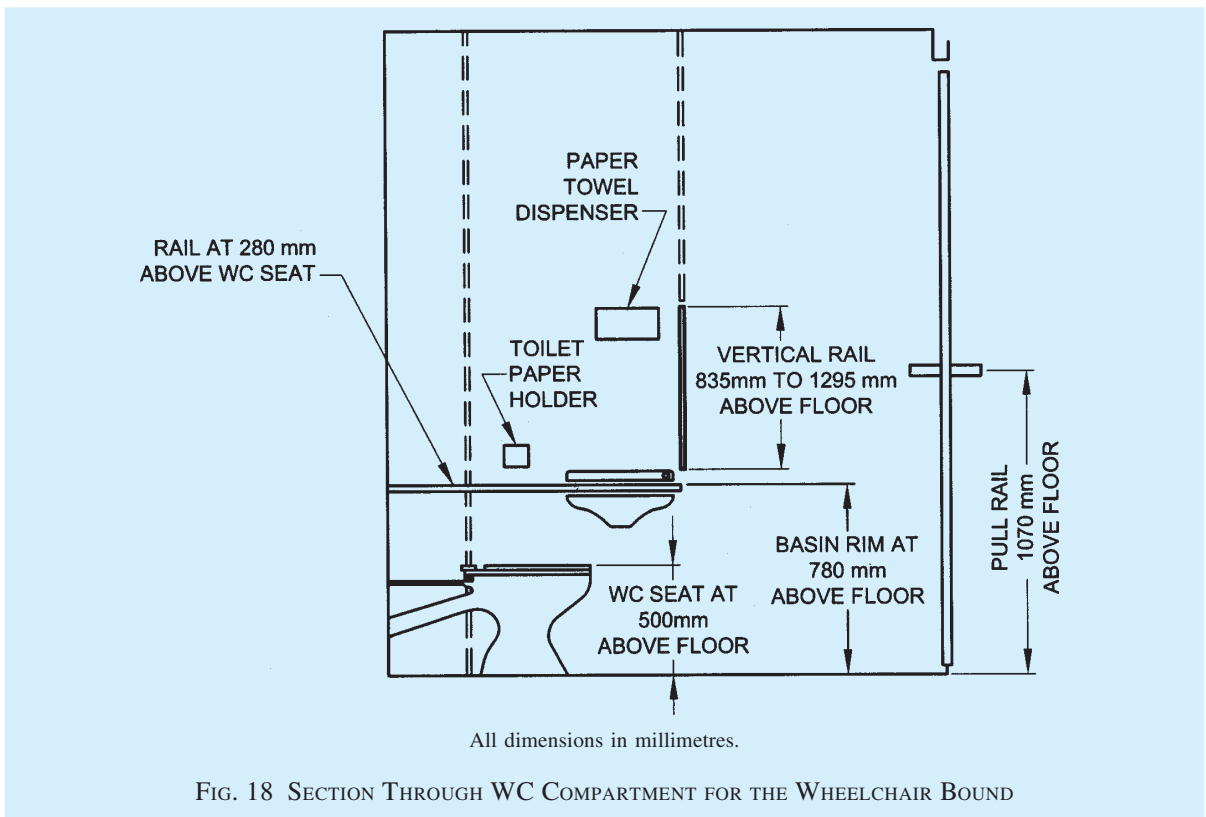

FIG. 18 SECTION THROUGH WC COMPARTMENT FOR THE WHEELCHAIR BOUND

D-3.7.2 Sanitary facilities shall have at least one water-closet cubical for the ambulant disabled (*see* Fig. 19 and 20), that:

- a) is 900 mm wide;
- b) is at least 1 500 mm, preferably 1 600 mm deep;
- c) has a door (where doors are used), that is, 800 mm wide and swings out;
- d) has handrails on each side, 780 mm high and parallel to the floor, 40 mm clearance between rail and wall, and fastened securely at ends and centre; and
- e) has a water-closet with the seat 500 mm from the floor.

NOTE — The design and mounting of the water-closet is of considerable importance. A wall-mounted water-closet with a narrow understructure that recedes sharply is most desirable. If a floor mounted water-closet must be used, it should not have a front that is wide and perpendicular to the floor at the front of the seat. The bowl should be shallow at the front of the seat and turn backwards more than downwards to allow the individual in a wheelchair to get close to the water-closet with the seat of the wheelchair.

D-3.7.3 Sanitary facilities shall have wash basins with narrow aprons, which when mounted at standard height are usable by individuals in wheelchairs; or they shall have wash basins mounted higher, when particular

designs demand, so that they are usable by individuals in wheelchairs.

D-3.7.3.1 The drain pipes and hot-water pipes under a sanitary appliance shall be covered or insulated so that a wheelchair individual do not find it inconvenient.

D-3.7.4 Some mirrors and shelves shall be provided above the wash basins at a height as low as possible and not higher than 1 m above the floor, measured from the top of the shelf and the bottom of the mirror.

D-3.7.5 Sanitary facilities for men shall have wall-mounted urinals with the opening of the basin 460 mm from the floor, or shall have floor-mounted urinals that are on level with the main floor of the toilet room.

D-3.7.6 Toilet rooms shall have an appropriate number of towel racks, towel dispensers, and other dispensers and disposal units mounted not higher than 910 mm from the floor.

D-3.8 Drinking Fountains

An appropriate number of drinking fountains or other water-dispensing means shall be accessible to and usable by the physically disabled.

D-3.8.1 Drinking water fountains or water coolers shall have up front spouts and control.

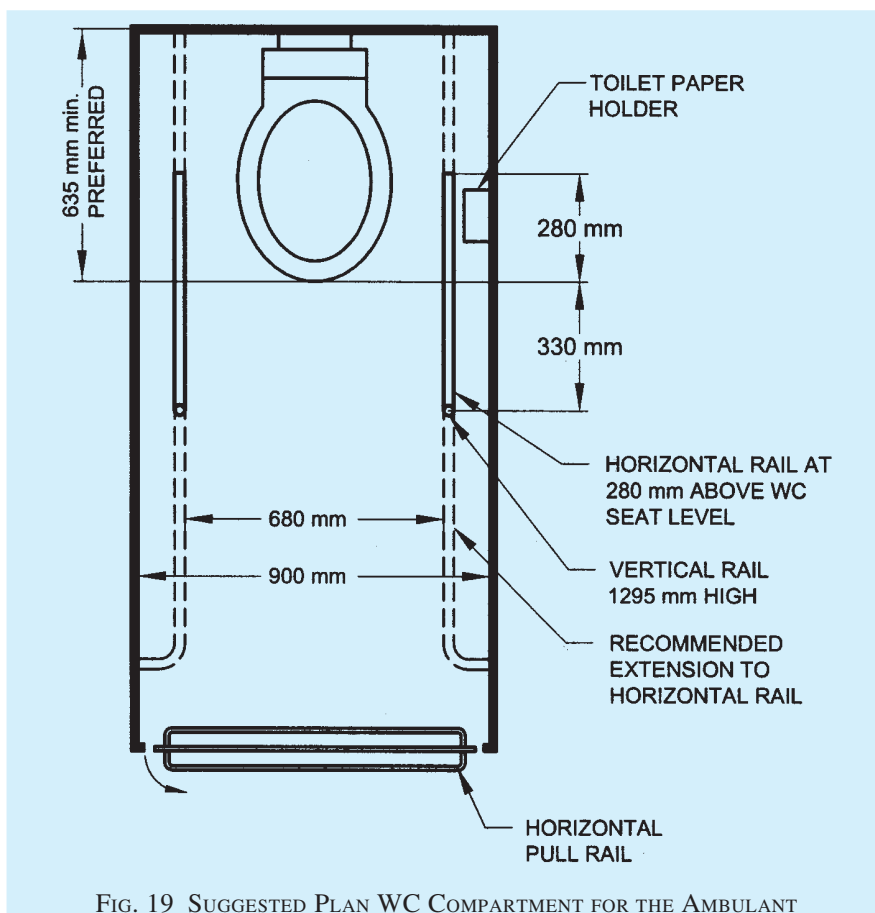

FIG. 19 SUGGESTED PLAN WC COMPARTMENT FOR THE AMBULANT

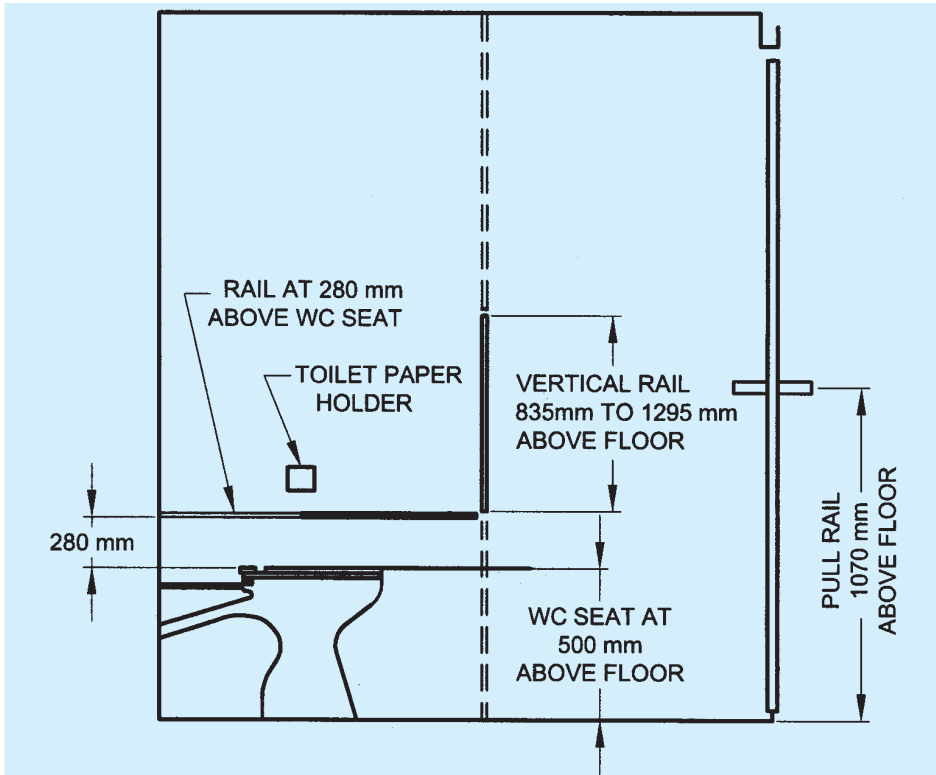

FIG. 20 SECTION THROUGH WC COMPARTMENT FOR THE AMBULANT DISABLED

D-3.8.2 Drinking water fountains or water coolers shall be hand-operated or hand and foot-operated.

D-3.8.2.1 Conventional floor-mounted water coolers may be convenient to individuals in wheelchairs if a small fountain is mounted on the side of the cooler 800 mm above the floor.

D-3.8.2.2 Fully recessed drinking water fountains are not recommended.

D-3.8.2.3 Drinking water fountains should not be set into an alcove unless the alcove is wider than a wheelchair.

D-3.9 Public Telephones

An appropriate number of public telephones should be made accessible to and usable by the physically disabled.

NOTE — The conventional public telephone booth is not usable by most physically disabled individuals. There are many ways in which public telephones may be made accessible and usable. It is recommended that architects and builders confer with the telephone companies in the planning of the building or facility.

D-3.9.1 Such telephones should be kept so that the dial is placed at minimum 1 200 mm from floor and the handset may be reached by individuals in wheelchairs.

D-3.10 Handrails

Handrails are used as a locational and mobility aid by blind and visually impaired people, and as a support for people with mobility impairments. The handrail should

be securely fitted to the wall to withstand heavy pressure. Handrails should turn in towards the wall at either end.

D-3.10.1 Handrails should be approximately 900 mm from the floor. The rail should be easy to grip, having a circular section with a diameter of approximately 40 mm and fixed as shown in Fig. 21.

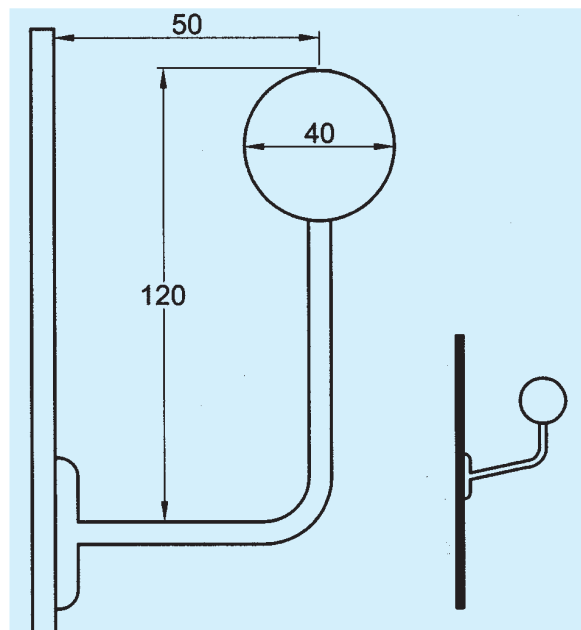

All dimensions in millimetres.

FIG. 21 FIXING OF HAND RAIL

D-3.10.2 To aid identification, the colour of the rail should contrast with the wall behind.

D-3.11 Elevators

In a multi-storey building, elevators are essential to the successful functioning of physically disabled individuals. They shall conform to the requirements given in **D-3.11.1** and **D-3.11.2**.

D-3.11.1 Elevators shall be accessible to, and usable by the physically disabled on the level that they use to enter the building, and at all levels normally used by the general public.

D-3.11.2 Elevators shall allow for traffic by wheelchairs (*see also D-3.3*).

D-3.12 Controls

It is advantageous for wheelchair users if controls are placed at low level. For visually impaired people, they should be at eye-level.

D-3.12.1 To enable wheelchair users to reach controls while not placing them too low for visually impaired people, controls should be in the zone 900 mm to 1 200 mm from the floor. It is advantageous if controls in, for example, lifts are placed at an angle of approximately 45° to the wall so that they are easier to read and operate. To cater for wheelchair users, controls should be placed not less than 400 mm from room corners. All the power and electric points should be placed at one metre above the floor level and should not project outside walls.

D-3.12.2 Again, to cater for visually impaired people, controls should be colour-contrasted with backgrounds. Information should preferably be in relief for tactile reading.

D-3.12.3 To aid operation for people with impaired co-ordination or impaired vision, switches, etc, should have large push plates.

D-3.12.4 Controls for powered door openers to hinged doors should be located so that the doors do not conflict with wheelchairs, sticks, walking aids, etc.

D-3.12.5 To facilitate operation for people with limited strength in arms and hands, handles should be easy to grip and turn.

D-3.13 Identification

Appropriate identification of specific facilities within a building used by the public is particularly essential to the blind.

D-3.13.1 Raised letters or numbers shall be used to identify rooms or offices.

D-3.13.2 Such identification should be placed on the

wall, to left of the door, preferably at a height of 1 500 mm from the floor.

D-3.13.3 Doors that are not intended for normal use, and that might prove dangerous if a blind person were to exit or enter by them, should be made quickly identifiable to the touch by knurling the door handle or knob (*see Fig. 22*).

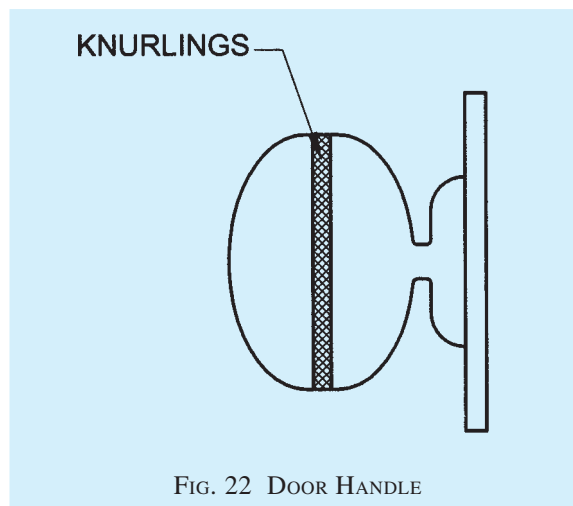

FIG. 22 DOOR HANDLE

D-3.14 Warning Signals

D-3.14.1 Audible warning signals shall be accompanied by simultaneous visual signals for the benefit of those with hearing disabilities.

D-3.14.2 Visual signals shall be accompanied by simultaneous audible signals for the benefit of the blind. To assist blind people, lettering and symbols on signs should be in relief for tactile reading.

D-3.14.3 Signs should be designed and located so that they are easy to read. For visually impaired people, signs should preferably be at eye-level and it should be possible to approach them closely. Text and symbols should be colour-contrasted with the background. The letters should not be less than 12 mm high.

D-3.14.4 Signs should be well illuminated and surfaces should not cause mirroring or reflections. Signs should not be behind glass or similar materials.

D-3.14.5 Information based on colour codes only should be avoided; colourblind people may find them difficult to understand.

D-3.15 Work Bench

This should be at least 800 mm wide, 600 mm deep and 650 mm to 700 mm high. For wheelchair users, the convenient height of work tops is between 750 mm and 850 mm; flexible provision is preferred. Further, for wheelchair access to a work bench, wash basin or table, a clear space for knees and footrests is needed.

D-3.16 Hazards

Every effort shall be exercised to obviate hazards to individuals with physical disabilities.

D-3.16.1 Access panels or manholes in floors, walks, and walls may be extremely hazardous, particularly when in use, and should be avoided.

D-3.16.2 When manholes or access panels are open and in use, or when an open excavation exists on a site, particularly when it is in proximity of normal pedestrian traffic, barricades shall be placed on all open sides, at least 8.5 m from the hazard, and warning devices shall be installed in accordance with **D-3.14.2**.

D-3.16.3 Low-hanging door closers that remain within the opening of a doorway, when the door is open or that protrude hazardously into regular corridors or traffic ways when the door is closed, shall be avoided.

D-3.16.4 Low-hanging signs, ceiling lights, and similar objects or signs and fixtures that protrude into regular corridors or traffic way shall be avoided. A

minimum height of 2.1 m measured from the floor is recommended.

D-3.16.5 Ramps shall be adequately lighted.

D-3.16.6 Exit signs shall be in accordance with good practices [3(5)].

D-3.16.7 Equipment and materials causing allergic reactions should as far as possible be avoided in dwellings and buildings.

D-4 DESIGNING FOR CHILDREN

The dimensions given in this Annex are for adults of average stature. In designing buildings for use by children, it may be necessary to alter some dimensions, such as, height of handrails, in accordance with accepted standards [3(6)].

D-5 For additional information regarding other facilities and conveniences required in buildings meant for use of physically challenged, reference may be made to accepted standards [3(7)].

ANNEX E

(Clauses 12.22, C-2.3.1 and C-2.6)

SPECIAL REQUIREMENTS OF CLUSTER PLANNING FOR HOUSING

E-1 GENERAL

E-1.1 These guidelines cover planning and building requirements of housing developed as clusters. These requirements are applicable to all housing projects taken up by public, private or co-operative agencies.

E-2 PLANNING

E-2.1 Plot Size

The minimum plot size permissible shall be 15 m² with 100 percent ground coverage and an FSI of two. Hundred percent ground coverage and FSI of 2 will be applicable up to plot size of 25 m². For plot sizes beyond 25 m², provision in accordance with good practice [3(1)] shall be applicable.

E-2.2 Plot/Plinth Area for Slum Resettlement on Same Site

In case of slum resettlement on the same site, minimum area may be reduced to 12.5 m² with potential for adding another 12.5 m² on first floor with an internal staircase.

E-2.3 Group Housing

Group housing may be permitted within cluster housing

concept. However, dwelling units with plinth areas up to 20 m² should have scope for adding a habitable room. Group housing in a cluster should not be more than 15 m in height.

E-2.4 Size of Cluster

In ground and one storeyed structures not more than 20 houses should be grouped in a cluster. Clusters with more dwelling units may create problems relating to identity, encroachment and maintenance.

E-2.5 Size of Cluster Open Space

Minimum dimensions of open spaces shall be not less than 6 m or 3/4th of the height of buildings along the cluster open space, whichever is higher. The area of such cluster court shall not be less than 36 m². Group housing around a cluster open space should not be normally more than 15 m in height. Maximum cluster courtyard width and breadth shall be 13 m.

E-2.6 Setbacks

No setbacks are needed from the edges of cluster as pedestrian/vehicular access roads surrounding the cluster.

E-2.7 Right to Build in Sky

Pedestrian paths and vehicular access roads to clusters separating two adjacent clusters may be bridged to provide additional dwelling units. While bridging the pedestrian path way minimum clearance should be one storey height, length of such bridging should be not more than two dwelling units. While bridging the vehicular access roads minimum clearance should be 6 m.

E-2.8 Vehicular Access

A right of way of at least 6 m width should be provided up to the entrance to the cluster to facilitate emergency vehicle movement up to cluster.

E-2.9 Pedestrian Paths

Minimum width of pedestrian paths shall be 3 m.

E-2.10 Width of Access Between Two Clusters

Built area of dwelling unit within cluster shall have no setbacks from the path or road, space. Hence, the height of the building along the pathway or roads shall be not less than 60 percent of the height of the adjacent building subject to minimum of 3 m in case of pathway and 6 m in case of vehicular access.

E-2.11 Density

Cluster planning methodologies result in higher densities with low rise structures. With per dwelling unit covered area of 15 m² densities of 500 dwelling units per hectare (net) shall be permissible. Densities higher than this should not allowed.

E-2.12 Group Toilet

Cluster housing for economically weaker section families can have group toilets at the rate of one water-closet, one bath and a washing place for three families. These shall not be community toilets, as keys to these toilets shall be only with these three families, making them solely responsible for the maintenance and upkeep of these toilets.

E-3 OTHER REQUIREMENTS

E-3.1 Requirements of Building Design

With the exception of clauses mentioned above, requirements of building will be governed by the provision of this Code and good practice [3(1)].

E-3.2 Requirements of fire safety, structural design, building services and plumbing services shall be as specified in this Code.

ANNEX F

(Clause 12.23)

SPECIAL REQUIREMENTS FOR LOW INCOME HABITAT PLANNING IN RURAL AREAS

F-1 GENERAL

F-1.1 These guidelines cover planning and general building requirements for low-income houses having a maximum built-up area of 40 m² including future expansion, built on notified (as notified by the State Governments) rural areas. The provisions on layout planning of low-income housing colonies in rural areas are applicable to public and private agencies/government bodies. The provisions of this Code on design and construction of buildings for low income housing in approved layouts are applicable to all private and public agencies.

F-2 SETTLEMENT AND ENVIRONMENT PLANNING

F-2.1 While planning for rural settlements the following factors shall be taken into consideration:

- a) Ecosystem and Biodiversity.
- b) Topography with its direct effect on climate,

likelihood of natural disasters, natural drainage, etc.

- c) Identity of the place rooted in its culture and heritage.
- d) Nearness and connectivity with nearby urban centres.
- e) Occupation related requirements.
- f) Water management.
- g) Waste management.
- h) Land tenure.
- j) Site selected shall be conveniently approachable and suitably developed and shall not be subjected to water logging/flooding.
- k) Plot size : 80 m², *Min*
- m) Density (Gross) : 60 plots per hectare, *Max*
- n) Minimum frontage : 6 m

- p) Ground Coverage : 33 percent (subject to a maximum of 50 percent)
- q) Floor area ratio (FAR): 2, *Max*
- r) Open spaces : 1.21 hectare open space for a village with 200 houses.
- s) Facilities like branch of co-operative bank, a fertilizer depot, a veterinary hospital, market place and a branch of the co-operative consumer store besides facilities for educational and health care should be available within a maximum distance of 5 km from any settlement.
- t) Proposed Road Hierarchy

Road Type	Road Description	Road Width	Function/Remarks
(1)	(2)	(3)	(4)
R1	Road which connects village to nearby areas	9 m	Widest road
R2	Road which take major traffic to the village	6 m	Main village roads with drain on both sides to facilitate drainage system of the village
R3	Internal village road	4.5 m	Other village roads
R4	Internal village road	3 m	Village lanes

F-3 GENERAL BUILDING REQUIREMENTS (HOMESTEAD)

F-3.1 General

The requirements of parts of buildings shall be as given in F-3.2 to F-3.7.

F-3.2 Plinth

The minimum height of plinth shall be regulated on the basis of environmental and topographical condition and higher plinth height may be required in areas prone to flooding.

F-3.3 Size of Room

F-3.3.1 Habitable Room

Every dwelling unit to be provided should have at least two habitable rooms. Even if one room house is provided initially it should be capable of adding a new second room in future. In a house of two rooms, first room shall not be less than 9.0 m² with minimum width of 2.5 m and second room shall not be less than 6.5 m² with a minimum width of 2.1 m provided the total area

of both the rooms is not less than 15.5 m². In incremental housing the bigger room shall always be the first room.

F-3.3.1.1 To facilitate incremental housing in case of flatted development or otherwise, habitable space at mezzanine level may be permitted. The minimum size of such a mezzanine floor should not be lesser than 6.5 m² and such a floor should occupy not more than 50 percent of the room area of which it is a part. Such a mezzanine floor should have appropriate openings to facilitate light and ventilation as per F-3.5. Minimum clear height below and above the mezzanine floor should be 2.4 m and 2.1 m respectively.

As far as possible mezzanine floor should have direct ventilation from the external face of the building. Where this is not possible ventilation through main room may be allowed provided total area of openings in the main room is provided taking into consideration area of mezzanine floor.

Such mezzanine floor may be accessible through the main room by a ladder, whose minimum angle with vertical plane should be 22½°. Height of the riser should be less than 250 mm.

F-3.3.2 Water-Closet/Bathroom

- The size of independent water-closet shall be 0.9 m²; with minimum width of 90 cm.
- The size of independent bathroom shall be 1.2 m² with minimum width of 1m, and
- The size of combined bath and water closet shall be 1.8 m² with minimum width of 1 m.

F-3.3.3 Kitchen

The size of a cooking alcove serving as cooking space shall not be less than 2.4 m² with a minimum width of 1.2 m. The size of individual kitchen shall not be less than 3.3 m² with a minimum width of 1.5 m. Semi-open spaces with low walls and roof may also be provided for cooking in areas where such provision is suitable with respect to climatic comfort. Provision for smokeless *CHULLHA* shall be made in all kitchens considering fuel efficiency and health hazard due to smoke inhalation.

F-3.3.4 Balcony

The minimum width of individual balcony, where provided, shall be 0.9 m and shall not be more than 1.2 m and it shall not project beyond the plot line and on roads or pathway.

F-3.4 Minimum Height

The minimum height of rooms/spaces shall be as follows:

- | | |
|----------------------|--------|
| a) Habitable room | 2.75 m |
| b) Kitchen | 2.6 m |
| c) Bath/water-closet | 2.2 m |
| d) Corridor | 2.1 m |

F-3.4.1 In the case of sloping roofs, the average height of roof for habitable rooms shall be 2.75 m and the minimum height at eaves shall be 2.10 m.

F-3.5 Lighting and Ventilation

The openings through windows, ventilators and other openings for lighting and ventilation shall be as per in accordance with **15.1.2**.

NOTE — The windows and other openings shall abut onto open spaces either through areas left open within the plot or the front, side and rear spaces provided in the layouts which shall be deemed to be sufficient for light and ventilation purposes. Wherever ventilation/lighting is provided by means of *JALI* or grill of any material, total area of openings shall be calculated excluding solid portion of the *JALI* or grill.

F-3.6 Stairs

The following criteria shall be adopted for internal individual staircase:

- | | |
|--------------------------------|--------------------|
| a) <i>Minimum width</i> | |
| 1) 2 storeyed-straight | 0.60 m |
| 2) 2 storeyed-winding | 0.75 m |
| 3) 3 or more storeyed-straight | 0.75 m |
| 4) 3 or more storeyed-winding | 0.90 m |
| b) <i>Riser</i> | 200 mm, <i>Max</i> |
| c) <i>Tread</i> | |
| 1) 2 storeyed | 225 mm, <i>Min</i> |
| 2) 3 storeyed or more | 250 mm, <i>Min</i> |

NOTE — This could be reduced to 20 cm as the clear tread between perpend, with possibility of open riser as well as nosing and inclined riser to have an effective going of 22.5 cm.

F-3.7 Water Seal Latrine

No building plan shall be approved and no building shall be deemed to have been completed and fit for human occupation unless provision is made for water seal latrine. No dry latrine shall be allowed. Water seal latrines can also be provide on the basis of community toilets or shared toilets as per the recommendation given in [3(3)].

Where leaching pits are used, it should be constructed within the premises of the households as it would be economical as well as facilitate their cleaning. However, where, due to space constraint, construction of pits within the premises may not be possible, pits may be constructed in places like lanes, streets and roads.

In case the pit is located under the road, street or foot path, the inverted level of the pipe connecting the

latrine pan with the pit shall be at least 1.1 m below ground level or below the bottom of the water main existing within a distance of 3 m from the pits whichever is more. Construction of such pits may be in accordance with [3(4)].

The water seal latrine should be properly maintained and kept in sanitary condition by the owner or the occupier. The contents of the septic tanks, soak pits, leach pits, etc, should be periodically emptied.

The leach pits should be cleaned only after 2 years of their being put out of service after they were full.

Location of sanitary facility either as part of the house or separately shall be decided on the basis of felt perceptions.

F-3.8 The house site shall provide space for storage of food grains and keeping cattle. A manure pit having a minimum area of 1.0 m² shall also be catered for. This will take care of composting of biodegradable waste.

F-4 OTHER REQUIREMENTS

F-4.1 Requirements of fire safety, structural design, building services and plumbing services shall be as specified in relevant parts of the Code.

F-4.2 One water tap per dwelling unit may be provided, where adequate drinking water supply is available. If supply is inadequate, public hydrants shall be provided. In the absence of piped water supply, hand pumps may be used for provision of water supply.

F-4.3 Drainage System

F-4.3.1 Water from drains shall be connected to village ponds and appropriate eco-friendly methods like growing of duck weed plants shall be adopted to treat waste water.

F-4.3.2 This treated water may be used for irrigation and agriculture.

F-4.4 Appropriate methods (namely conservation, ground water recharging, rain water harvesting, etc.) should be employed to ensure effective water management.

F-4.5 Community Facilities

F-4.5.1 A community hall/*BARAAT GHAR* shall be established.

F-4.5.2 Rural Development Centre shall include *PANCHAYAT GHAR*, a *MAHILA KENDRA* that may also serve as a vocational training centre.

F-4.5.3 School, health centre, post office, police post, shopping, work sheds for the artisans, telephone facilities, etc should also be established.

F-4.6 The use (to the extent possible) of locally

available building materials and cost effective substitutes for scarce building materials. Appropriate technology inputs shall be introduced for improving the local materials or conventional or traditional practices for improved efficiency.

F-4.7 The concept of 'aided self-help' shall be ensured for active participation of the prospective users and association in the construction and development of dwelling units and other community building.

F-4.8 The special needs of women headed households/ single and working women/woman in difficult circumstances should be addressed. The specific requirement of women in terms of providing necessary facilities in homes to lessen their drudgery would be given sufficient attention.

F-4.9 Protecting and promoting our cultural heritage, architecture and traditional skills should be given due importance.

ANNEX G

(Clause 12.24)

SPECIAL REQUIREMENTS FOR DEVELOPMENT PLANNING IN HILLY AREAS

G-1 GENERAL

G-1.1 These guidelines provides requirements relating to development planning and design of buildings in hilly areas. Any area above 600 m in height from mean sea level may be classified as hilly, or any area with average slope of 30° may also be classified as hilly, considering the sensitive and fragile eco-system of hills and mountains. However, the State Governments may identify and notify areas to be covered under 'Hilly Area', which need to be dealt with special consideration, when developmental activities are taken up.

G-1.2 Hilly areas have one of the most fragile eco-systems, which need to be conserved. Therefore planning and development strategies for hilly areas shall have to be designed with added sensitivity and stress on integrated development. The development approach shall comprise sound land use planning and settlement planning.

G-1.3 Settlement planning in the hill areas has extremely large implications on the environment. For planning of the new settlements or working out the strategies for the growth of the existing settlements, it is necessary to conduct detailed environmental inventory/impact assessment. The inventory would involve geological investigations, slope analysis, soil, flora and fauna analysis, climatic inventories, vulnerability to natural disasters, etc. In addition to this the aesthetic factors, cultural, architectural and historical heritage, scenic/landscape value should also be taken into consideration. Keeping in view the scarcity of good buildable land and also the high cost of the construction, it is necessary to optimize the use of land and at the same time, use cost effective, appropriate building materials and technologies.

G-2 LAND USE PLANNING

G-2.1 The following land use structure shall be adopted in Development Planning in Hilly areas:

<i>Land Use</i>	<i>Percentage of Developed Area</i>		
	Small Towns	Medium Towns	Large Cities
(1)	(2)	(3)	(4)
Residential	50-55	48-52	45-50
Commercial	2-3	2-3	4-5
Industrial	3-4	4-5	5-7
Public and semi-public	8-10	8-10	12-15
Recreational	15-18	15-18	18-20
Transport and commerce	5-6	5-6	6-8
Ecological	8-10	8-10	8-10

G-3 OPEN SPACES

G-3.1 The following standards shall be adopted in Development Planning in Hilly areas.

<i>Type</i>	<i>Area Range</i>	<i>Area per 1 000 Population</i>	<i>Remarks</i>
(1)	(in ha) (2)	(in ha) (3)	(4)
Tot lot	0.03-0.05	—	Minimum width 15 m
Playground	0.50-1.00	0.12 to 0.20	One for every 5 000 may be combined with schools.
Parks	1.20-2.00	0.12 to 0.20	One for every 10 000 population.
City parks/playgrounds/ <i>maidan</i> / exhibition grounds/cultural gathering grounds	—	0.12 to 0.20	For the entire town at one of more sites, depending upon design and space availability.
Botanical garden	10-20	—	One for every town
Recreational complex including zoo	10-12	—	One for every settlement with tourist potential

G-4 ROADS AND PATHS

G-4.1 Street orientation shall preferably be East-West to allow for maximum South sun to enter the buildings. The street shall be wide enough to ensure that the

buildings on one side do not shade those on the other side.

G-4.2 The following road widths shall be adopted for urban roads in Hilly areas.

<i>Road Type</i>	<i>Width (in m)</i>		
	Open Areas	Built-up Areas	Plains
(1)	(2)	(3)	(4)
Arterial road	18-24	15-18	50-60
Sub-arterial road	15-18	12-15	30-40
Collector road	9-12	7.5-9	20-30
Local street	4.5-6	3-6	10-20
Loop street (maximum length = 500 m)	4.5	4.5	9
Cul-de-sac (maximum length = 500 m)	4.5	4.5	7.5
Pedestrian path	1.5-2.5	1-1.5	1.5-4.5

G-4.3 Hill Road Manual (IRC:SP:48-1998), a publication of the Indian Roads Congress shall be referred to for detailed guidelines for planning roads in Hilly areas.

G-5 COMMUNITY FACILITIES AND SERVICES

G-5.1 The following standards shall be adopted for community facilities and Services in Hilly areas.

<i>Type</i>	<i>Population</i>	<i>Distance</i>	<i>Area Range (in ha)</i>
(1)	(2)	(3)	(4)
<i>A. Educational</i>			
Primary school	4 000	1-2	0.20 to 0.30
Secondary school (10+2)	15 000	5-7	0.30 to 0.50
Industrial training centre	—	8-12	0.30 to 0.60
College	30 000	8-12	2.00 to 3.00

<i>Type</i>	<i>Population</i>	<i>Distance</i>	<i>Area Range</i> (in ha)
(1)	(2)	(3)	(4)
B. Health			
Health sub-centre	3 000	2-4	0.025 to 0.067
Primary health centre (25-50 beds)	20 000 80 000	16-20 16-20	0.105 to 0.210 0.840 to 2.100
Hospital (200-250 beds)	1 000	16-20	0.050 to 0.100
Veterinary centre			
C. Other facilities			
Community welfare centre	16 000	5-7	0.10 to 0.15
D. Services			
Fire station	50 000	—	0.30 to 0.80
General post office	50 000	10-15	0.20 to 0.40
Post office	10 000	5-7	0.10 to 0.15
Rural post office	2 000	2-4	0.025 to 0.050
Rural post office	1 000	1-2	—
Bank (tribal areas)	10 000	16-20	0.100 to 0.150
Telephone exchange	50 000	10-15	0.20 to 0.40
Electric sub-station (66 kV)	—	—	1.00
Electric sub-station (11 kV)	—	—	0.05
LPG godown	—	—	0.15

G-6 GENERAL BUILDING REQUIREMENTS

G-6.1 General

The provisions contained in this Part shall apply excepting for the specific provisions given hereunder.

G-6.2 Siting

G-6.2.1 No house shall preferably be located closer than 1 m to another house.

G-6.2.2 No house shall be located closer than 10 m to a steep slope.

G-6.2.3 No house shall be built on a landfill or on the edge of a slope known to have been levelled.

G-6.2.4 Buildings in hills shall be clustered together to minimise the exposure to cold winds. Open spaces provided shall allow for maximum South sun.

G-6.2.5 Buildings shall be located on the south slope of a hill or mountain for better exposure to solar radiation. At the same time, exposure to cold winds may be minimized by locating the building on the leeward side.

G-6.3 Passive Systems for Climatic Control

G-6.3.1 Appropriate solar passive methods, such as orientation, double-glazing, trombe walls and solar collectors, shall be adopted to achieve climatic comfort with little use of conventional energy.

G-6.3.2 Care shall be taken in siting and design of buildings to provide passive controls to modify the effect of cold/strong winds.

G-6.4 Flat land is normally not available in hilly regions. The houses are required to be constructed on partially sloping land made available by cutting and filling. It shall be necessary to protect the house by building retaining walls/breast walls [see 3(8)] to avoid landslides occurring at time of earthquakes or heavy rains.

G-6.5 Disaster Resistance

All necessary steps shall be taken in designing and building in hilly regions to achieve disaster resistance as per the relevant codes and Part 6 'Structural Design'. All natural disasters likely to affect the locality shall be taken into consideration, namely earthquakes, cyclones, avalanches, flash floods, landslides etc.

LIST OF STANDARDS

The following list records those standards which are acceptable as 'good practice' and 'accepted standards' in the fulfillment of the requirements of the Code. The latest version of a standard shall be adopted at the time of enforcement of the Code. The standards listed may be used by the Authority as a guide in conformance with the requirements of the referred clauses in the Code.

<i>IS No.</i>	<i>Title</i>	<i>IS No.</i>	<i>Title</i>
(1) 8888 (Part 1) : 1993	Guide for requirements of low income housing: Part 1 Urban area (<i>first revision</i>)	(4) 12314 : 1987	Code of practice for sanitation for leaching pits for rural community
(2) 3792 : 1978 11907 : 1986	Guide for heat insulation of non-industrial buildings (<i>first revision</i>) Recommendations for calculation of solar radiation on buildings	(5) 4878 : 1986	Byelaws for construction of cinema buildings (<i>first revision</i>)
(3) 13727 : 1993	Guide for requirements of cluster planning for housing	(6) 4838 : 1990	Anthropometric dimensions for school children age group 5-17 years (<i>second revision</i>)
		(7) 4963 : 1987	Recommendations for buildings and facilities for the physically challenged (<i>first revision</i>)
		(8) 14458	Guidelines for retaining walls for hill area:
		(Part 1) : 1998	Selection of type of wall
		(Part 2) : 1997	Design of retaining/breast walls

NATIONAL BUILDING CODE OF INDIA

PART 4 FIRE AND LIFE SAFETY

BUREAU OF INDIAN STANDARDS

CONTENTS

FOREWORD	...	3
1 SCOPE	...	7
2 TERMINOLOGY	...	7
3 FIRE PREVENTION	...	9
4 LIFE SAFETY	...	26
5 FIRE PROTECTION	...	32
6 ADDITIONAL OCCUPANCY-WISE REQUIREMENTS	...	49
ANNEX A CALORIFIC VALUES OF COMMON MATERIALS AND TYPICAL VALUES OF FIRE LOAD DENSITY	...	62
ANNEX B BROAD CLASSIFICATION OF INDUSTRIAL AND NON-INDUSTRIAL OCCUPANCIES INTO DIFFERENT DEGREE OF HAZARD	...	63
ANNEX C FIRE PROTECTION REQUIREMENTS FOR HIGH RISE BUILDINGS — 15 m IN HEIGHT OR ABOVE	...	65
ANNEX D FIRE PROTECTION CONSIDERATIONS FOR VENTING IN INDUSTRIAL BUILDINGS	...	71
ANNEX E GUIDELINES FOR FIRE DRILL AND EVACUATION PROCEDURES FOR HIGH RISE BUILDINGS (ABOVE 15 m IN HEIGHT)	...	77
LIST OF STANDARDS	...	83

FOREWORD

This Part of the Code deals with safety from fire. It specifies the demarcation of fire zones, restrictions on construction of buildings in each fire zone, classification of buildings based on occupancy, types of building construction according to fire resistance of the structural and non-structural components and other restrictions and requirements necessary to minimize danger to life from fire, smoke, fumes or panic before the buildings can be evacuated. The Code recognizes that safety of life is more than a matter of means of exits and accordingly deals with various matters which are considered essential to the safety of life.

Fire protection techniques have to be based on the fire behaviour characteristics of different materials and structural elements of buildings. The activities pursued by the occupants of buildings must also be taken into consideration for assessing the extent of hazards, and method should then be devised by which the hazards could be minimized. An indefinite combination of variables is involved in the phenomenon of fire, all of which cannot be quantified. The requirements of this Code should, therefore, be taken as a guide and an engineering design approach should be adopted for ensuring a fire safe design for buildings. It would also be necessary for this purpose to associate qualified and trained fire protection engineers with the planning of buildings, so that adequate fire protection measures could be incorporated in the building design right from the beginning.

Absolute safety from fire is not attainable in practice. The objective of this Part is to specify measures that will provide that degree of safety from fire which can be reasonably achieved. The Code endeavours to avoid requirements that might involve unreasonable hardships or unnecessary inconvenience or interference with normal use and occupancy of buildings, but insists upon compliance with minimum standards for fire safety necessary in public interest. For ensuring compliance of fire protection equipments/installations to the laid down quality requirements, it is desirable to use such equipments/installation duly certified under the BIS Certification Marks Scheme.

While providing guidelines for minimizing chances of occurrence of fire through passive fire protection measures, this Part does not intend to cover all aspects of general fire prevention including sources of ignition. Nor does it cover the prevention of accidental personal injuries during the course of normal occupancy of buildings.

This Part while recognizing that panic in a building on fire may be uncontrollable, deals with the potential panic hazard through measures designed to prevent the development of panic. Experience indicates that panic seldom develops even in the presence of potential danger, so long as occupants of buildings are moving towards exits which they can see within a reasonable distance and with no obstruction or undue congestion in the path of travel. However, any uncertainty as to the location or adequacy of means of egress, the presence of smoke or fumes and the stoppage of travel towards the exit, such as may occur when one person stumbles and falls on stairs, may be conducive to panic. Danger from panic is greater when a large number of people are trapped in a confined area.

Experience has shown that concealed spaces within a building, such as, space between ceiling and false ceiling, horizontal and vertical ducts, etc, tend to act as flues/tunnels during a fire. Provision should, therefore, be made to provide fire stopping within such spaces.

Nothing in this Part of the Code shall be construed to prohibit better types of building construction, more exits or otherwise safer conditions than the minimum requirements specified in this Part.

Compliance with this Part shall not be construed as eliminating or reducing the necessity for other provisions for safety of persons using a building or structure under normal occupancy conditions. Nor shall any provision of this Code be construed as requiring or permitting any addition that may be hazardous under normal occupancy conditions.

One of the major points brought out in this Part is the limitation of heights and areas of buildings based on fire safety of the occupants. Individual municipal corporations are free to alter Table 19 based on local conditions,

but the ratios of areas as maintained in the table for different occupancies and types of construction shall be adhered to.

Advantage has been taken of the developments, particularly in fire resistance rating of materials, designating types of construction in a rational manner and relating the area limitations of different occupancies to different types of construction.

Halons (halogenated hydrocarbons) which exhibit exceptional fire fighting and explosion prevention/suppression characteristics have been found to possess high ozone depleting potential. They come under Group II of Annex A of the Montreal Protocol on Substances that Deplete the Ozone Layer, the international environmental agreement for phasing out ozone depleting substances. Due to increasing evidence that the ozone layer is getting depleted at a faster rate than thought earlier, the developed countries accelerated their phase-out schedule with a view to achieving 100 percent phase-out of halons by 1 January 1994, instead of the earlier target date of 1 January 2000 after which only essential use of halon was allowed. For developing countries like India, the total phase-out of halons is to be achieved by 1 January 2010, as per Montreal Protocol, unless a decision is taken in between to hasten up the phase-out of ozone depleting substances. India, having become a signatory to the Protocol in June 1992, is committed to abide by the Montreal Protocol decisions. In accordance with Ministry of Environment and Forests, Government of India, Ozone Depleting Substances (Regulations), Rules, 2000, the manufacture of halon based fire extinguishers and extinguishing systems has been phased out by 1 January 2001. Meanwhile, the practical implications of the phasing out of the halons cover, by and large, the following aspects:

- a) Availability of halons will be restricted;
- b) Non-standard halon extinguishers, like aerosol type, shall not be permitted;
- c) Discharge of halons for training/testing, etc shall not be permitted;
- d) All efforts shall be made for avoiding/minimizing halon emissions at various levels such as production, fire equipment manufacture, use, service and maintenance;
- e) Since 'drop-in' substitutes for halons are not likely to be available on a commercial scale in the near future, wherever possible, instead of halon, use of suitable alternative extinguishing media/methods will be resorted to, even accepting some trade-offs, if necessary; and
- f) Halons shall be restricted for 'essential uses' only, for protection of critical fire explosion risk areas which would otherwise result in serious impairment of an essential service to society, or pose an unacceptable threat to life, the environment, or national security.

NOTE — Detailed instructions which will be issued by the Government of India from time-to-time for implementation of the Country Programme for the phasing out of ozone depleting substance (ODS) and regarding permitting use of halons for applications till the availability of proper substitutes, shall have to be complied with.

The first version of this Part was formulated in 1970 and first revision was brought out in 1983. Subsequently the first revision of this Part was modified in 1997 through Amendment No. 3 to 1983 version of the Code. This modified version of this part included few tables for the fire resistance ratings of various building components, such as walls, columns, beams and floors. The requirements for wet riser, down-comer, automatic sprinkler installation, high velocity (10-15 m/s) water spray or foam generating system, etc, for buildings were modified. Annex giving guidelines for selection of fire detectors had been deleted and relevant Indian Standards on fire alarm system and smoke detectors had been referred. Also, Annex for determination of fire loads and fire load density for arriving at the classification of occupancy hazard and calorific values of some common materials were included. Annex for broad classification of industrial and non-industrial occupancies into low, moderate and high hazard had also been included.

As a result of implementation of this Part, some useful suggestions have emerged. This revision has, therefore, been prepared to take care of the same. The significant modifications incorporated include:

- a) The text has now been divided into the following broad clauses:
 - 1) *Fire Prevention* — Covering aspects of fire prevention pertaining to design and construction of buildings on passive fire protection measures, also describing the various types of building materials and their fire rating.
 - 2) *Life Safety* — Covering life safety provisions in the event of fire and similar emergencies, also addressing construction and occupancy features that are necessary to minimize danger to life from fire, smoke, fumes or panic.

- 3) *Fire Protection* — covering the significant appurtenances and their related components and guidelines for selecting the correct type of equipment and installation meant for fire protection of the building, depending upon the classification and type of the building.
- b) The classification of building based on occupancy has been elaborated, with:
 - 1) Starred hotels now covered as a new sub-division A-6 under occupancy Group A Residential.
 - 2) Heritage structures and archeological monuments now covered under sub-division D-3 occupancy Group D Assembly buildings.
 - 3) Mixed assembly occupancies now covered as a new sub-division D-6 and under ground elevated railways have been covered as a new sub-division D-7 under occupancy Group D Assembly buildings.
 - 4) TV stations now covered under sub-division E-5 of occupancy Group E Business buildings.
- c) The minimum capacity of smoke exhaust equipment has been increased to 12 air changes per hour.
- d) For the external stairs for exit requirements, the width and treads have been increased to 1 250 mm and 250 mm respectively.
- e) Under the requirements for institutional buildings the clear width of all required exits which serve as egress from hospital or infirmary section has been increased from 1.5 m to 2 m. Also, provision of patient-lift has been included.
- f) Due cognizance of halon phase out programme has been taken, while specifying provisions in this Part with respect to fire protection using fire extinguishers/systems.

All standards cross-referred to in the main text of this section, are subject to the revision. The parties to agreement based on this Part are encouraged to investigate the possibility of applying the most recent editions of the standards.

NATIONAL BUILDING CODE OF INDIA

PART 4 FIRE AND LIFE SAFETY

1 SCOPE

This Part covers the requirements for fire prevention, life safety in relation to fire and fire protection of buildings. The Code specifies construction, occupancy and protection features that are necessary to minimize danger to life and property from fire.

2 TERMINOLOGY

2.0 For the purpose of this Part, the following definitions shall apply.

2.1 Automatic Fire Detection and Alarm System

— Fire alarm system comprising components for automatically detecting a fire, initiating an alarm of fire and initiating other actions as appropriate.

NOTE — The system may also include manual fire alarm call points.

2.2 Automatic Sprinkler System — A system of water pipes fitted with sprinkler heads at suitable intervals and heights and designed to actuate automatically, control and extinguish a fire by the discharge of water.

2.3 Building — Any structure for whatsoever purpose and of whatsoever materials constructed and every part thereof whether used as human habitation or not and includes foundation, plinth, walls, floors, roofs, chimneys, plumbing and building services, fixed platforms, *VERANDAH*, balcony, cornice or projection, part of a building or anything affixed thereto or any wall enclosing or intended to enclose any land or space and signs and outdoor display structures. Tents, *SHAMIANAHS*, tarpaulin shelters, etc, erected for temporary and ceremonial occasions with the permission of the Authority shall not be considered as building.

2.4 Building, Height of — The vertical distance measured in the case of flat roofs, from the average level of the ground around and contiguous to the building or as decided by the Authority to the terrace of the last livable floor of the building adjacent to the external wall; and in the case of pitched roofs, up to the point where the external surface of the outer wall intersects the finished surface of the sloping roof; and in the case of gables facing the road, the mid-point between the eaves level and the ridge. Architectural features serving no other function except that of decoration, shall be excluded for the purpose of measuring heights.

2.5 Combustible Material — The material which either burns itself or adds heat to a fire, when tested for non-combustibility in accordance with accepted standard [4(1)].

2.6 Covered Area — Ground area covered by the

building immediately above the plinth level. The area covered by the following in the open spaces is excluded from covered area (*see* Table 19):

- a) garden, rockery, well and well structures, plant nursery, waterpool, swimming pool (if uncovered), platform round a tree, tank, fountain, bench, *CHABUTARA* with open top and unenclosed on sides by walls and the like;
- b) drainage culvert, conduit, catch-pit, gully pit, chamber, gutter and the like;
- c) compound wall, gate, unstoreyed porch and portico, slide, swing, uncovered staircases, ramp areas covered by *CHHAJJA* and the like; and
- d) watchman's booth, pumphouse, garbage shaft, electric cabin or sub-stations, and such other utility structures meant for the services of the building under consideration.

NOTE — For the purpose of this Part, covered area equals the plot area minus the area due for open spaces in the plot.

2.7 Down-comer — An arrangement of fire fighting within the building by means of down-comer pipe connected to terrace tank through terrace pump, gate valve and non-return valve and having mains not less than 100 mm internal diameter with landing valves on each floor/landing. It is also fitted with inlet connections at ground level for charging with water by pumping from fire service appliances and air release valve at roof level to release trapped air inside.

2.8 Dry Riser — An arrangement of fire fighting within the building by means of vertical rising mains not less than 100 mm internal diameter with landing valves on each floor/landing which is normally dry but is capable of being charged with water usually by pumping from fire service appliances.

2.9 Emergency Lighting — Lighting provided for use when the supply to the normal lighting fails.

2.10 Emergency Lighting System — A complete but discrete emergency lighting installation from the standby power source to the emergency lighting lamp(s), for example, self-contained emergency luminaire or a circuit from central battery generator connected through wiring to several escape luminaires.

2.11 Escape Lighting — That part of emergency lighting which is provided to ensure that the escape route is illuminated at all material times, for example, at all times when persons are on the premises, or at times the main lighting is not available, either for the whole building or for the escape routes.

2.12 Fire Door — A fire-resistive door approved for openings in fire separation.

2.13 Fire Exit — A way out leading to an escape route having panic bar hardware provided on the door.

2.14 Fire Lift — The lift installed to enable fire services personnel to reach different floors with minimum delay, having such features as required in accordance with this Part.

2.15 Fire Load — Calorific energy, of the whole contents contained in a space, including the facings of the walls, partitions, floors and ceilings.

2.16 Fire Load Density — Fire load divided by floor area.

2.17 Fire Resistance Rating — The time that a material or construction will withstand the standard fire exposure as determined by fire test done in accordance with the standard methods of fire tests of materials/structures.

2.18 Fire Resistance — Fire resistance is a property of an element of building construction and is the measure of its ability to satisfy for a stated period some or all of the following criteria:

- a) resistance to collapse,
- b) resistance to penetration of flame and hot gases, and
- c) resistance to temperature rise on the unexposed face up to a maximum of 180°C and/or average temperature of 150°C.

2.19 Fire Separation — The distance in metres measured from the external wall of the building concerned to the external wall of any other building on the site, or from other site, or from the opposite side of street or other public space for the purpose of preventing the spread of fire.

2.20 Fire Separating Wall — The wall provides complete separation of one building from another or part of a building from another or part of a building from another part of the same building to prevent any communication of fire or heat transmission to wall itself which may cause or assist in the combustion of materials on the side opposite to that portion which may be on fire.

2.21 Fire Stop — A fire resistant material, or construction, having a fire resistance rating of not less than the fire separating elements, installed in concealed spaces or between structural elements of a building to prevent the spread/propagation of fire and smoke through walls, ceilings and like as per the laid down criteria.

2.22 Fire Tower — An enclosed staircase which can only be approached from the various floors through landings or lobbies separated from both the floor areas

and the staircase by fire-resisting doors, and open to the outer air.

2.23 Fire Resisting Wall — A fire resistance rated wall, having protected openings, which restricts the spread of fire and extends continuously from the foundation to at least 1 m above the roof.

2.24 Floor Area Ratio (FAR) — The quotient obtained by dividing the total covered area (plinth area) on all floors by the area of the plot:

$$\text{FAR} = \frac{\text{Total covered area of all floors}}{\text{Plot area}}$$

2.25 High Rise Building — For the purpose of this Part, all buildings 15 m or above in height shall be considered as high rise buildings.

2.26 Horizontal Exit — An arrangement which allows alternative egress from a floor area to another floor at or near the same level in an adjoining building or an adjoining part of the same building with adequate fire separation.

2.27 Means of Egress — A continuous and unobstructed way of travel from any point in a building or structure to a place of comparative safety.

2.28 Occupancy or Use Group — The principal occupancy for which a building or a part of a building is used or intended to be used; for the purpose of classification of a building according to the occupancy, an occupancy shall be deemed to include subsidiary occupancies which are contingent upon it.

2.29 Plinth Area — The built-up covered area measured at the floor level of the basement or of any storey.

2.30 Pressurization — The establishment of a pressure difference across a barrier to protect a stairway, lobby, escape route or room of a building from smoke penetration.

2.31 Pressurization Level — The pressure difference between the pressurized space and the area served by the pressurized escape route, expressed in pascals (Pa).

2.32 Roof Exits — A means of escape on to the roof of a building, where the roof has access to it from the ground. The exit shall have adequate cut-off within the building from staircase below.

2.33 Site Plot — A parcel (piece) of land enclosed by definite boundaries.

2.34 Stack Pressure — Pressure difference caused by a temperature difference creating an air movement within a duct, chimney or enclosure.

2.35 Travel Distance — The distance to be travelled from any point in a building to a protected escape route, external escape route or final exit.

2.36 Ventilation — Supply of outside air into, or the removal of inside air from an enclosed space.

2.37 Venting Fire — The process of inducing heat and smoke to leave a building as quickly as possible by such paths that lateral spread of fire and heat is checked, fire fighting operations are facilitated and minimum fire damage is caused.

2.38 Volume to Plot Area Ratio (VPR) — The ratio of volume of building measured in cubic metres to the area of the plot measured in square metres and expressed in metres.

2.39 Wet Riser — An arrangement for fire fighting within the building by means of vertical rising mains not less than 100 mm nominal diameter with landing valves on each floor/landing for fire fighting purposes and permanently charged with water from a pressurized supply.

NOTE — For definitions of other terms, reference shall be made to good practice [4(2)].

3 FIRE PREVENTION

3.1 Classification of Building Based on Occupancy

3.1.1 General Classification

All buildings, whether existing or hereafter erected shall be classified according to the use or the character of occupancy in one of the following groups:

Group A	Residential
Group B	Educational
Group C	Institutional
Group D	Assembly
Group E	Business
Group F	Mercantile
Group G	Industrial
Group H	Storage
Group J	Hazardous

3.1.1.1 Minor occupancy incidental to operations in another type of occupancy shall be considered as part of the main occupancy and shall be classified under the relevant group for the main occupancy.

Examples of buildings in each group are given in **3.1.2** to **3.1.10**.

3.1.2 Group A Residential Buildings

These shall include any building in which sleeping accommodation is provided for normal residential purposes with or without cooking or dining or both facilities, except any building classified under Group C.

Buildings and structures under Group A shall be further sub-divided as follows:

Sub-division A-1 Lodging or rooming houses

Sub-division A-2 One or two-family private dwellings

Sub-division A-3 Dormitories

Sub-division A-4 Apartment houses (flats)

Sub-division A-5 Hotels

Sub-division A-6 Hotels (Starred)

a) *Sub-division A-1 Lodging or rooming houses* — These shall include any building or group of buildings under the same management, in which separate sleeping accommodation for a total of not more than 40 persons (beds), on transient or permanent basis, with or without dining facilities but without cooking facilities for individuals is provided. This includes inns, clubs, motels and guest houses.

A lodging or rooming house shall be classified as a dwelling in sub-division A-2 if no room in any of its private dwelling units is rented to more than three persons.

b) *Sub-division A-2 One or two-family private dwellings* — These shall include any private dwelling which is occupied by members of one or two families and has a total sleeping accommodation for not more than 20 persons.

If rooms in a private dwelling are rented to outsiders, these shall be for accommodating not more than three persons per room.

If sleeping accommodation for more than 20 persons is provided in any one residential building, it shall be classified as a building in sub-division A-1, A-3 or A-4 as the case may be.

c) *Sub-division A-3 Dormitories* — These shall include any building in which group sleeping accommodation is provided, with or without dining facilities for persons who are not members of the same family, in one room or a series of closely associated rooms under joint occupancy and single management, for example, school and college dormitories, students, and other hostels and military barracks.

d) *Sub-division A-4 Apartment houses (flats)* — These shall include any building or structure in which living quarters are provided for three or more families, living independently of each other and with independent cooking facilities, for example, apartment houses, mansions and chawls.

e) *Sub-division A-5 Hotels* — These shall include any building or group of buildings under single management, in which sleeping accommodation is provided, with or without dining facilities for hotels classified up to 4 Star Category.

- f) *Sub-division A-6 Hotels (starred)* — These shall include the hotels duly approved by the concerned authorities as Five Star and above Hotels.

3.1.3 Group B Educational Buildings

These shall include any building used for school, college, other training institutions for day-care purposes involving assembly for instruction, education or recreation for not less than 20 students.

Buildings and structures under Group B shall be further sub-divided as follows:

Sub-division B-1 Schools up to senior secondary level

Sub-division B-2 All others/training institutions

- a) *Sub-division B-1 Schools up to senior secondary level* — This sub-division shall include any building or a group of buildings under single management which is used for students not less than 20 in number.
- b) *Sub-division B-2 All others/training institutions* — This sub-division shall include any building or a group of buildings under single management which is used for students not less than 100 in number.

In the case of temporary buildings/structures which are utilized for educational purposes, the provisions of 3.2.5.3 shall apply.

If residential accommodation is provided in the schools/institutions, that portion of occupancy shall be classified as a building in sub-division A-3.

3.1.4 Group C Institutional Buildings

These shall include any building or part thereof, which is used for purposes, such as medical or other treatment or care of persons suffering from physical or mental illness, disease or infirmity; care of infants, convalescents or aged persons and for penal or correctional detention in which the liberty of the inmates is restricted. Institutional buildings ordinarily provide sleeping accommodation for the occupants.

Buildings and structures under Group C shall be further sub-divided as follows:

Sub-division C-1 Hospitals and sanatoria

Sub-division C-2 Custodial institutions

Sub-division C-3 Penal and mental institutions

- a) *Sub-division C-1 Hospitals and sanatoria* — This sub-division shall include any building or a group of buildings under single management, which is used for housing persons suffering from physical limitations because of health or age, for example, hospitals, infirmaries, sanatoria and nursing homes.

- b) *Sub-division C-2 Custodial institutions* — This sub-division shall include any building or a group of buildings under single management, which is used for the custody and care of persons, such as children, convalescents and the aged, for example, homes for the aged and infirm, convalescent homes and orphanages.

- c) *Sub-division C-3 Penal and mental institutions* — This sub-division shall include any building or a group of buildings under single management, which is used for housing persons under restraint, or who are detained for penal or corrective purposes, in which the liberty of the inmates is restricted, for example, jails, prisons, mental hospitals, mental sanatoria and reformatories.

3.1.5 Group D Assembly Buildings

These shall include any building or part of a building, where number of persons not less than 50 congregate or gather for amusement, recreation, social, religious, patriotic, civil, travel and similar purposes, for example, theatres, motion picture houses, assembly halls, auditoria, exhibition halls, museums, skating rinks, gymnasiums, restaurants, places of worship, dance halls, club rooms, passenger stations and terminals of air, surface and marine public transportation services, recreation piers and stadia, etc.

Buildings under Group D shall be further sub-divided as follows:

Sub-division D-1 Buildings having a theatrical or motion picture or any other stage and fixed seats for over 1 000 persons

Sub-division D-2 Buildings having a theatrical or motion picture or any other stage and fixed seats upto 1 000 persons

Sub-division D-3 Buildings without a permanent stage having accommodation for 300 or more persons but no permanent seating arrangement.

Sub-division D-4 Buildings without a permanent stage having accommodation for less than 300 persons with no permanent seating arrangement.

Sub-division D-5 All other structures including temporary structures designed for assembly of people not covered by sub-divisions D-1 to D-4, at ground level.

Sub-division D-6 Buildings having mixed occupancies providing facilities such as shopping, cinema theatres, and restaurants.

Sub-division D-7 All other structures, elevated or underground, for assembly of people not covered by sub-divisions D-1 to D-6.

- a) *Sub-division D-1* — This sub-division shall

include any building primarily meant for theatrical or operatic performances and exhibitions and which has a raised stage, proscenium curtain, fixed or portable scenery or scenery loft, lights, motion picture houses, mechanical appliances or other theatrical accessories and equipment and which is provided with fixed seats for over 1 000 persons.

- b) *Sub-division D-2* — This sub-division shall include any building primarily meant for use as described for sub-division D-1, but with fixed seats up to 1 000 persons.
- c) *Sub-division D-3* — This sub-division shall include any building, its lobbies, rooms and other spaces connected thereto, primarily intended for assembly of people, but which has no theatrical stage or permanent theatrical and/or cinematographic accessories and has accommodation for 300 persons or more, for example, dance halls, night clubs, halls for incidental picture shows, dramatic, theatrical or educational presentation, lectures or other similar purposes having no theatrical stage except a raised platform and used without permanent seating arrangement; art galleries exhibition halls, community halls, marriage halls, places of worship, museums, lecture halls, passenger terminals and Heritage and Archeological Monuments.
- d) *Sub-division D-4* — This sub-division shall include any building primarily intended for use as described in sub-division D-3, but with accommodation for less than 300 persons with no permanent seating arrangements.
- e) *Sub-division D-5* — This sub-division shall include any building or structure permanent or temporary meant for assembly of people not covered by sub-divisions D-1 to D-4, for example, grandstands, stadia, amusement park structures, reviewing stands and circus tents.
- f) *Sub-division D-6* — This sub-division shall include any building for assembly of people provided with multiple services/facilities like shopping, cinema theatres and restaurants, for example, multiplexes.
- g) *Sub-division D-7* — This sub-division shall include any building or structure permanent or temporary meant for assembly of people not covered by D-1 to D-6, for example, underground or elevated railways.

3.1.6 Group E Business Buildings

These shall include any building or part of a building which is used for transaction of business (other than that covered by Group F and part of buildings covered

by **3.1.1.1**); for keeping of accounts and records and similar purposes, professional establishments, service facilities, etc. City halls, town halls, court houses and libraries shall be classified in this group so far as the principal function of these is transaction of public business and keeping of books and records.

Business buildings shall be further sub-divided as follows:

Sub-division E-1 Offices, banks, professional establishments, like offices of architects, engineers, doctors, lawyers and police stations.

Sub-division E-2 Laboratories, research establishments, libraries and test houses.

Sub-division E-3 Computer installations.

Sub-division E-4 Telephone exchanges.

Sub-division E-5 Broadcasting stations and T.V. stations.

3.1.7 Group F Mercantile Buildings

These shall include any building or part of a building, which is used as shops, stores, market, for display and sale of merchandise, either wholesale or retail.

Mercantile buildings shall be further sub-divided as follows:

Sub-division F-1 Shops, stores, departmental stores markets with area up to 500 m².

Sub-division F-2 Shops, stores, departmental stores markets with area more than 500 m².

Sub-division F-3 Underground shopping centres. Storage and service facilities incidental to the sale of merchandise and located in the same building shall be included under this group.

3.1.8 Group G Industrial Buildings

These shall include any building or part of a building or structure, in which products or materials of all kinds and properties are fabricated, assembled, manufactured or processed, for example, assembly plants, industrial laboratories, dry cleaning plants, power plants, generating units, pumping stations, fumigation chambers, laundries, buildings or structures in gas plants, refineries, dairies and saw-mills, etc.

Buildings under Group G shall be further sub-divided as follows:

Sub-division G-1 Buildings used for low hazard industries.

Sub-division G-2 Buildings used for moderate hazard industries.

Sub-division G-3 Buildings used for high hazard industries.

The hazard of occupancy, for the purpose of the Code, shall be the relative danger of the start and spread of

fire, the danger of smoke or gases generated, the danger of explosion or other occurrences potentially endangering the lives and safety of the occupants of the buildings.

Hazard of occupancy shall be determined by the Authority on the basis of the fire loads of the contents, and the processes or operations conducted in the building, provided, however, that where the combustibility of the material, the flame spread rating of the interior finish or other features of the building or structure are such as to involve a hazard greater than the occupancy hazard, the greater degree of hazard shall govern the classification.

For determination of fire loads and fire load density for arriving at the classification of occupancy hazard, guidance including the calorific values of some common materials, is given at Annex A.

A broad classification of industrial and non-industrial occupancies into low, moderate and high hazard classes is given at Annex B, for guidance. Any occupancy not covered in Annex B, shall be classified in the most appropriate class depending on the degree of hazard.

Where different degrees of hazard of occupancy exist in different parts of a building, the most hazardous of those shall govern the classification for the purpose of this Code, except in cases where hazardous areas are segregated or protected as specified in the Code.

- a) *Sub-division G-1* — This sub-division shall include any building in which the contents are of such comparative low combustibility and the industrial processes or operations conducted therein are of such a nature that there are hardly any possibilities for any self propagating fire to occur and the only consequent danger to life and property may arise from panic, fumes or smoke, or fire from some external source.
- b) *Sub-division G-2* — This sub-division shall include any building in which the contents or industrial processes or operations conducted therein are liable to give rise to a fire which will burn with moderate rapidity or result in other hazardous situation and may give off a considerable volume of smoke, but from which neither toxic fumes nor explosions are to be feared in the event of fire.
- c) *Sub-division G-3* — This sub-division shall include any building in which the contents or industrial processes or operations conducted therein are liable to give rise to a fire which will burn with extreme rapidity or result in other hazardous situation or from which poisonous fumes or explosions are to be feared in the event of a fire. For fire safety in petroleum and fertilizer plant, good practice [4(3)] may be referred.

3.1.9 Group H Storage Buildings

These shall include any building or part of a building used primarily for the storage or sheltering (including servicing, processing or repairs incidental to storage) of goods, ware or merchandise (except those that involve highly combustible or explosive products or materials) vehicles or animals, for example, warehouses, cold storage, freight depots, transit sheds, storehouses, truck and marine terminals, garages, hangers, grain elevators, barns and stables. Storage properties are characterized by the presence of relatively small number of persons in proportion to the area. Any new use which increase the number of occupants to a figure comparable with other classes of occupancy shall change the classification of the building to that of the new use, for example, hangars used for assembly purposes, warehouses used for office purposes, garage buildings used for manufacturing.

3.1.10 Group J Hazardous Buildings

These shall include any building or part of a building which is used for the storage, handling, manufacture or processing of highly combustible or explosive materials or products which are liable to burn with extreme rapidity and or which may produce poisonous fumes or explosions for storage, handling, manufacturing or processing which involve highly corrosive, toxic or noxious alkalis, acids or other liquids or chemicals producing flame, fumes and explosive, poisonous, irritant or corrosive gases; and for the storage, handling or processing of any material producing explosive mixtures of dust which result in the division of matter into fine particles subject to spontaneous ignition. Examples of buildings in this class are those buildings which are used for:

- a) Storage, under pressure of more than 0.1 N/mm^2 and in quantities exceeding 70 m^3 , of acetylene, hydrogen, illuminating and natural gases, ammonia, chlorine, phosgene, sulphur dioxide, carbon dioxide, methyloxide and all gases subject to explosion, fume or toxic hazard, cryogenic gases, etc;
- b) Storage and handling of hazardous and highly flammable liquids, liquefiable gases like LPG, rocket propellants, etc;
- c) Storage and handling of hazardous and highly flammable or explosive materials (other than liquids); and
- d) Manufacture of artificial flowers, synthetic leather, ammunition, explosives and fireworks.

NOTE — A list of hazardous substances giving quantities, for which or exceeding which owners handling such substances are required to be covered under the Public Liability Insurance Act, has been notified under Government of India, Ministry of Environment and Forests Notification No. G.S.R. 347(E) dated 1 August 1996.

3.1.11 Any building not covered by Annex B or **3.1.8** shall be classified in the group which most nearly resembles its existing or proposed use.

3.1.12 Where change in the occupancy of any building places it in a different group or in a different subdivision of the same group, such building shall be made to comply with the requirements of the Code for the new group or its sub-division.

3.1.13 Where the new occupancy of a building is less hazardous, based on life and fire risk, than its existing occupancy, it shall not be necessary to conform to the requirements of the Code for the new group or its sub-division.

3.1.14 A certificate of occupancy shall be necessary, as required under Part 2 'Administration', before any change is effected in the character of occupancy of any building.

3.2 Fire Zones

3.2.1 Demarcation

The city or area under the jurisdiction of the Authority shall for the purpose of the Code, be demarcated into distinct zones, based on fire hazard inherent in the buildings and structures according to occupancy (*see 3.1*), which shall be called as 'Fire Zones'.

3.2.2 Number and Designation of Fire Zones

3.2.2.1 The number of fire zones in a city or area under the jurisdiction of the Authority depends upon the existing layout, types of building construction (*see 3.3*), classification of existing buildings based on occupancy (*see 3.1*) and expected future development of the city or area. In large cities or areas, three fire zones may be necessary, while in smaller ones, one or two may be adequate.

3.2.2.2 The fire zones shall be made use of in land use development plan and shall be designated as follows:

- a) *Fire Zone No. 1* — This shall comprise areas having residential (Group A), educational (Group B), institutional (Group C), and assembly (Group D), small business (Sub-divisions E-1) and retail mercantile (Group F) buildings, or areas which are under development for such occupancies.
- b) *Fire Zone No. 2* — This shall comprise business (Sub-divisions E-2 to E-5) and industrial buildings (Sub-division G-1 and G-2), except high hazard industrial buildings (Sub-division G-3) or areas which are under development for such occupancies.
- c) *Fire Zone No. 3* — This shall comprise areas having high hazard industrial buildings (Sub-division G-3), storage buildings (Group H) and buildings for hazardous used (Group J)

or areas which are under development for such occupancies.

3.2.3 Change in the Fire Zone Boundaries

When the boundaries of any fire zone are changed, or when it is intended to include other areas or types of occupancies in any fire zone, it shall be done by following the same procedure as for promulgating new rules or ordinances or both.

3.2.4 Overlapping Fire Zones

3.2.4.1 When any building is so situated that it extends to more than one fire zone, it shall be deemed to be in the fire zone in which the major portion of the building or structure is situated.

3.2.4.2 When any building is so situated that it extends equally to more than one fire zone, it shall be deemed to be in the fire zone having more hazardous occupancy buildings.

3.2.5 Temporary Buildings or Structures

3.2.5.1 Temporary buildings and structures shall be permitted only in Fire Zones No. 1 and 2 as the case may be, according to the purpose for which these are to be used, by special permit from the Authority for a limited period and subject to such conditions as may be imposed in the permit.

3.2.5.2 Such buildings and temporary structures shall be completely removed on the expiry of the period specified in the permit.

3.2.5.3 Adequate fire precautionary measures in the construction of temporary structures and *PANDALS* shall be taken in accordance with good practice [4(4)].

3.2.6 Restrictions on the Type of Construction for New Buildings

3.2.6.1 Buildings erected in Fire Zone No. 1 shall conform to construction of Type 1, 2, 3 or 4.

3.2.6.2 Buildings erected in Fire Zone No. 2 shall conform to construction of Type 1, 2 or 3.

3.2.6.3 Buildings erected in Fire Zone No. 3 shall conform to construction of Type 1 or 2.

3.2.7 Restrictions on Existing Buildings

The existing buildings in any fire zone shall not be required to comply with the requirement of the Code unless these are altered, or in the opinion of the Authority, such building constitutes a hazard to the safety of the adjacent property or the occupants of the building itself or is an unsafe building. In the event of alteration, it shall be necessary to obtain permission of the Authority for such alteration consistent with fire hazard (*see Part 2 'Administration'*).

Alterations/modifications/renovations shall be accomplished so as to ensure conformity with all the

safety requirements of the new buildings. Such alterations shall not in anyway bring down level of fire and life safety below that which existed earlier. Any addition or alterations or construction of cubicles or partitioning for floor area exceeding 500 m² for all high rise buildings shall be with approval of local fire authority.

3.3 Types of Construction

3.3.1 General

The design of any building and the type of materials used in its construction are important factors in making the building resistant to a complete burn-out and in preventing the rapid spread of fire, smoke or fumes, which may otherwise contribute to the loss of lives and property.

The fire resistance of a building or its structural and non-structural elements is expressed in hours against a specified fire load which is expressed in kcal/m², and against a certain intensity of fire. The fire-resistance test for structural element shall be done in accordance with good practice [4(5)]. For the purpose of the Code, the types of construction according to fire resistance shall be classified into four categories, namely,

Type 1 Construction, Type 2 Construction, Type 3 Construction and Type 4 'Construction'. The fire resistance ratings for various types of construction for structural and non-structural members shall be as given in Table 1.

For buildings 15 m in height or above non-combustible materials should be used for construction and the internal walls of staircase enclosures should be of brick work or reinforced concrete or any other material of construction with minimum of 2 h rating. The walls for the chimney shall be of Type 1 and Type 2 Construction depending on whether the gas temperature is above 200°C or less.

3.3.2 It is required that an element/component shall have the requisite fire resistance rating when tested in accordance with the accepted standard [4(1)]. Tables 2 to 18 provide available data regarding fire resistance ratings of various building components such as walls, columns, beams and floors. Fire damage assessment, post fire structural safety assessment of various structural elements of the building and adequacy of the structural repairs can be done by the fire resistance ratings mentioned in Tables 2 to 18.

Table 1 Fire Resistance Ratings of Structural and Non-Structural Elements (Hours)

(Clause 3.3.1)

Sl No.	Structural Element	Type of Construction				
		Type 1	Type 2	Type 3	Type 4	
(1)	(2)	(3)	(4)	(5)	(6)	
i)	Exterior walls:					
a)	Fire separation less than 3.7 m	a) Bearing	4	2	2	1
		b) Non-bearing	2	1½	1	1
b)	Fire separation of 3.7 m or more but less than 9 m	a) Bearing	4	2	2	1
		b) Non-bearing	1½	1	1	1
c)	Fire separation of 9 m or more	a) Bearing	4	2	2	1
		b) Non-bearing	1	1	1	1
ii)	Fire resisting walls		4	2	2	2
iii)	Fire separation assemblies (like fire check doors)		4	2	2	2
iv)	Fire enclosures of exitways, hallways and stairways		2	2	2	2
v)	Shaft other than exitways, elevator and hoistways		2	2	2	2
vi)	Exitway access corridors		1	1	1	1
vii)	Vertical separation of tenant spaces		1	1	1	1
viii)	Dwelling unit separation		1	1	1	1
	Non-load bearing partitions		— At least half an hour —			
ix)	Interior bearing walls, bearing partitions, columns, girders, trusses (other than roof trusses) and framing	a) Supporting more than one floor	4	2	2	2
		b) Supporting one floor only	3	1½	1	1
		c) Supporting a roof only	3	1½	1	1
x)	Structural members support walls		3	1½	1	1
xi)	Floor construction including walls		3	1½	1	1
xii)	Roof construction	a) 5 m or less in height to lowest member	2	1½	1	1
		b) More than 5 m but less than 6.7 m in height to lowest member	1	1	1	1
		c) 6.7 m or more in height to lowest member	0	0	0	0

Table 2 Masonry Walls: Solid (Required to Resist Fire from One Side at a Time)

(Clause 3.3.2)

Sl No.	Nature of Construction and Materials	Minimum Thickness (mm), Excluding any Finish for a Fire Resistance (Hours) of										
		Load Bearing					Non-load Bearing					
		1	1½	2	3	4	1	1½	2	3	4	
(1)	(2)	(3)	(4)	(5)	(6)	(7)	(8)	(9)	(10)	(11)	(12)	
i)	Reinforced ¹⁾ cement concrete	120 (25) ²⁾	140 (25) ²⁾	160 (25) ²⁾	200 (25) ²⁾	240 (25) ²⁾						
ii)	Unreinforced cement concrete	150	175	—	—	—						
iii)	No-fines concrete with :											
	a) 13 mm cement/sand or gypsum/sand	—	—	—	—	—	150	150	150	150	150	
	b) 13 mm light weight aggregate gypsum plaster	—	—	—	—	—	150	150	150	150	150	
iv)	Bricks of clay:											
	a) Without finish	90	100	100	170	170	75	90	100	170	170	
	b) With 13 mm lightweight aggregate gypsum plaster	90	90	90	100	100	75	90	90	90	100	
v)	Bricks of sand lime:											
	a) Without finish	90	100	100	190	190	75	90	100	170	170	
	b) With 13 mm lightweight aggregate gypsum plaster	90	90	90	100	100	75	90	90	90	100	
vi)	Blocks of concrete:											
	a) Without finish	90	100	100	—	—	75	90	100	140	150	
	b) With 13 mm lightweight aggregate gypsum plaster	90	90	90	100	100	75	75	75	90	100	
	c) With 13 mm cement/sand or gypsum/sand	—	—	—	—	—	75	90	90	100	140	
vii)	Blocks of lightweight concrete:											
	a) Without finish	90	100	100	140	150	75	75	75	125	140	
	b) With 13 mm lightweight aggregate gypsum plaster	90	90	90	100	100	50	63	75	75	75	
	c) With 13 mm cement/sand or gypsum/sand	—	—	—	—	—	75	75	75	90	100	
viii)	Blocks of aerated concrete:											
	a) Without finish	90	100	100	140	180	50	63	63	75	100	
	b) With 13 mm lightweight aggregate gypsum plaster	90	90	100	100	150						

¹⁾ Walls containing at least 1 percent of vertical reinforcement.

²⁾ Minimum thickness of actual cover to reinforcement.

Table 3 Masonry Walls: Hollow (Required to Resist Fire from One Side at a Time)

(Clause 3.3.2)

Sl No.	Nature of Construction and Materials	Minimum Thickness (mm), Excluding any Finish for a Fire Resistance (Hours) of											
		Load Bearing						Non-load Bearing					
		1	1½	2	3	4	½	1	1½	2	3	4	
(1)	(2)	(3)	(4)	(5)	(6)	(7)	(8)	(9)	(10)	(11)	(12)	(13)	
i)	Bricks of clay:												
	a) Without finish	170	170	170	200	200	75	75	90	100	170	170	
	b) With 13 mm lightweight aggregate gypsum plaster	100	100	170	170	170	75	75	90	90	90	100	
ii)	Blocks of concrete:												
	a) Without finish	—	—	—	—	—	90	125	125	140	140	150	
	b) With 13 mm cement/sand or gypsum/sand	190	200	200	—	—	90	125	125	140	140	140	
	c) With 13 mm lightweight aggregate gypsum plaster	—	—	—	—	—	75	90	90	100	125	125	
iii)	Blocks of lightweight concrete:												
	a) Without finish	100	100	100	—	—	75	90	90	100	140	150	
	b) With 13 mm cement/sand or gypsum/sand	—	—	—	—	—	75	75	75	100	140	140	
	c) With 13 mm lightweight aggregate gypsum plaster	—	—	—	—	—	63	63	63	75	90	100	

Table 4 Framed Construction, Load Bearing (Required to Resist Fire from One Side at a Time)

(Clause 3.3.2)

Sl No.	Nature of Construction and Materials/Timber Studs at Centres not Exceeding 600 mm, Faced on Each Side with	Minimum Thickness (mm) of Protection for a Fire Resistance of 1h
(1)	(2)	(3)
i)	Plasterboard layers with joints staggered, joints in outer layer taped and filled — Total thickness for each face	25
ii)	One layer of 12.7 mm plasterboard with a finish of lightweight aggregate gypsum plaster	13
iii)	Metal lath and plaster, thickness of plaster:	
	a) Sanded gypsum plaster (metal lathing grade)	22
	b) Lightweight aggregate gypsum plaster	13

Table 5 Framed Construction, Non-Load Bearing (Required to Resist Fire from One Side at a Time)

(Clause 3.3.2)

Nature of Construction and Materials/Steel or Timber Frame at Centres not Exceeding 600 mm, Facings on Both Sides of	Stud Construction	Minimum Thickness (mm) of Protection for a Fire Resistance			
		½ h	1 h	1½ h	2 h
(1)	(2)	(3)	(4)	(5)	(6)
A) Dry lining with materials fixed direct to studs (without plaster finish)					
1. One layer of plasterboard with taped and filled joints	Timber or steel	12.7			
2. Two layers of plasterboard with joints staggered, joints in outer layer taped and filled — Total thickness for each face	Timber or steel	19	25		
3. One layer of asbestos insulating board with transverse joints backed by fillers of asbestos insulating board not less than 9 mm thick, or by timber	Timber or steel	9	12		
4. One layer of wood wool slabs	Timber	25			
5. One layer of chipboard or of plywood	Timber or steel	18			
B) Lining with materials fixed direct to studs, with plaster finish:					
Plasterboard of thickness:					
a) With not less than 5 mm gypsum plaster finish	Timber or steel	9.5			
b) With not less than 13 mm gypsum plaster finish			12.7		
C) Wet finish:					
Metal lath and plaster, thickness of plaster:					
a) Sanded gypsum plaster	Timber or steel	13			
b) Lightweight aggregate gypsum plaster	Timber		13	19	25
	Steel		13		

Table 6 Framed External Walls Load Bearing (Required to Resist Fire from One Side at a Time)

(Clause 3.3.2)

Sl No.	Nature of Construction and Materials	Minimum Thickness (mm) of Protection for a Fire Resistance of 1 h
(1)	(2)	(3)
	Timber studs at centers not exceeding 600 mm with internal linings of :	
i)	Plasterboard layers with joints in outer layer taped and filled, total thickness of plasterboard	25

**Table 7 Framed External Walls Non-Load Bearing Required to Resist Fire only
from Inside the Building (A)**
(Clause 3.3.2)

Nature of Construction and Materials (1)	Minimum Thickness (mm) of Protection for a Fire Resistance					
	½ h (2)	1 h (3)	1½ h (4)	2 h (5)	3 h (6)	4 h (7)
Steel frame with an external cladding of non-combustible sheets (excluding sheet steel), with a steel supporting framework and internal lining of:						
1. Metal lath and plaster, thickness of plaster:						
a) Sanded gypsum plaster (metal lathing grade)	13	13				
b) Lightweight aggregate gypsum plaster	10	13	15	15	15	19
2. Two layer of plasterboard with joints staggered joints in outer layer taped and filled — Total thickness	21	32				
3. Plasterboard of thickness:						
a) With not less than 5 mm gypsum plaster finish	12.7					
b) With not less than 13 mm gypsum plaster finish	9.5					
c) With not less than 10 mm lightweight aggregate gypsum plaster	9.5					
4. One layer of asbestos insulating board with transverse joints backed by fillers of asbestos insulating board not less than 9 mm thick, or by timber	9	9	12	12	12	12
5. One layer of wood/wool slabs without finish		50				
6. One layer of compressed straw building slabs:						
a) Without finish	50					
b) With not less than 5 mm gypsum plaster finish		50				
7. Aerated concrete blocks	50	50	63	63	75	100
8. Bricks of clay:						
a) Without finish	75	75	90	90	100	100
b) With not less than 13 mm lightweight aggregate gypsum plaster			75	75	90	90

**Table 8 Framed External Walls Non-Load Bearing Required to Resist Fire only
from Inside the Building (B)**
(Clause 3.3.2)

Nature of Construction and Materials (1)	Minimum Thickness (mm) of Protection to Provide Sufficient Insulation to Achieve a Modified Fire Resistance of Up to 4 h (2)
Steel frame with an external cladding of sheet steel fully lapped, steel bolted and fixed to steel sheeting rails, with timber or steel supporting framework and internal lining of:	
1. Metal lath and plaster, thickness of plaster:	
a) Sanded gypsum plaster (metal lathing grade)	13
b) Lightweight aggregate gypsum plaster	10
2. One layer of plasterboard with joints taped and filled	12.7
3. Plasterboard of thickness with not less than 5 mm gypsum plaster finish	9.5
4. One layer of asbestos insulating board with transverse joints backed by fillers of asbestos insulating board not less than 9 mm thick, or by timber	9
5. One layer of wood/wool slabs	25
6. One layer of compressed straw building slabs	50
7. One layer of chipboard or of plywood	18
8. Aerated concrete blocks	50
9. Bricks of clay	75
10. Any internal decorative lining with a cavity fill independently supported and retained in position of mineral fibre insulating material (excluding glass) at a density of 48 kg/m ³	50

Table 9 Framed Walls Non-Load Bearing Required to Resist Fire only from Inside the Building (C)
(Clause 3.3.2)

Nature of Construction and Materials (1)	Minimum Thickness (mm) of Protection for a Fire Resistance of 1½ h (2)
Timber frame with external cladding of weather boarding or external plywood, 9.5 mm with an internal lining of:	
1. Plasterboard not less than 9.5 mm thick, finished with:	
a) Gypsum plaster	13
b) Lightweight aggregate gypsum plaster	10
2. Plasterboard not less than 12.7 mm thick, finished with:	
a) Gypsum plaster	10
b) Lightweight aggregate gypsum plaster	10
3. One layer of asbestos insulating board with transverse joints backed by fillers of asbestos insulating board not less than 9 mm thick, or by timber	9 12

Table 10 Reinforced Concrete Columns
(Clause 3.3.2)

Sl No.	Nature of Construction and Materials	Minimum Dimensions (mm) Excluding any Finish, for a Fire Resistance of						
		½ h	1 h	1½ h	2 h	3 h	4 h	
(1)	(2)	(3)	(4)	(5)	(6)	(7)	(8)	
i)	Fully exposed	Width	150	200	250	300	400	450
		Cover	40	40	40	40	40	40
ii)	50 percent exposed	Width	125	160	200	200	300	350
		Cover	40	40	40	40	40	40
iii)	One face exposed	Thickness	100	120	140	160	200	240
		Cover	40	40	40	40	40	40

Table 11 Concrete Beams
(Clause 3.3.2)

Sl No.	Nature of Construction and Materials	Minimum Dimensions (mm) Excluding any Finish, for a Fire Resistance of						
		½ h	1 h	1½ h	2 h	3 h	4 h	
(1)	(2)	(3)	(4)	(5)	(6)	(7)	(8)	
i)	Reinforced concrete (simply supported)	Width	200	200	200	200	240	280
		Cover	20	20	20	40	60 ¹⁾	70 ¹⁾
ii)	Reinforced concrete (continuous)	Width	200	200	200	200	240	280
		Cover	20	20	20	30	40	50 ¹⁾
iii)	Prestressed concrete (simply supported)	Width	100	120	150	200	240	280
		Cover	25	40	55	70	80	90
iv)	Prestressed concrete (continuous)	Width	80	100	120	150	200	240
		Cover	20	30	40	55	70	80

¹⁾ Require attention to the additional measures necessary to reduce the risk of spalling.

Table 12 Concrete Floors
(Clause 3.3.2)

Sl No.	Nature of Construction and Materials	Minimum Dimensions (mm) Excluding any Finish, for a Fire Resistance of						
		½ h	1 h	1½ h	2 h	3 h	4 h	
(1)	(2)	(3)	(4)	(5)	(6)	(7)	(8)	
i)	Reinforced concrete (simply supported)	Thickness	75	95	110	125	150	170
		Cover	20	20	25	35	45 ¹⁾	55 ¹⁾
ii)	Reinforced concrete (continuous)	Thickness	75	95	110	125	150	170
		Cover	20	20	20	25	35	45 ¹⁾

¹⁾ Require attention to the additional measures necessary to reduce the risk of spalling.

Table 13 Concrete Floors: Ribbed Open Soffit

(Clause 3.3.2)

Sl No.	Nature of Construction and Materials		Minimum Dimensions (mm) Excluding any Finish, for a Fire Resistance of					
			½ h	1 h	1½ h	2 h	3 h	4 h
(1)	(2)		(3)	(4)	(5)	(6)	(7)	(8)
i)	Reinforced concrete (simply supported)	Thickness of floor	75	95	110	125	150	170
		Rib width	125	125	125	125	150	175
		Cover	20	20	35	45	55	65
ii)	Reinforced concrete (continuous)	Thickness	75	95	110	125	150	170
		Width	125	125	125	125	150	175
		Cover	20	20	20	35	45	55

**Table 14 Encased Steel Columns, 203 mm × 203 mm
(Protection Applied on Four Sides)**

(Clause 3.3.2)

Nature of Construction and Materials		Minimum Dimensions (mm) Excluding any Finish, for a Fire Resistance of				
		1 h	1½ h	2 h	3 h	4 h
(1)		(2)	(3)	(4)	(5)	(6)
A) Hollow protection (without an air cavity over the flanges):						
1.	¹⁾ Metal lathing with trowelled lightweight aggregate gypsum plaster	13	15	20	32	
2.	Plasterboard with 1.6 mm wire binding at 100 mm pitch, finished with lightweight aggregate gypsum plaster not less than the thickness specified:					
	a) 9.5 mm plaster board	10	15			
	b) 19 mm plaster board			10	13	20
3.	Asbestos insulating boards, thickness of board:					
	a) Single thickness of board, with 6 mm cover fillets at transverse joints		19	25		
	b) Two layers, of total thickness				38	50
4.	Solid bricks of clay, composition or sand lime, reinforced in every horizontal joint, unplastered	50	50	50	75	100
5.	Aerated concrete blocks	60	60	60		
6.	Solid blocks of lightweight concrete hollow protection (with an air cavity over the flanges)	50	50	50	60	75
B)	Asbestos insulating board screwed to 25 mm asbestos battens	12	19			
C) Solid protections						
1.	Concrete, not leaner than 1:2:4 mix (unplastered):					
	a) Concrete not assumed to be load bearing, reinforced ²⁾	25	25	25	50	75
	b) Concrete assumed to be load bearing	50	50	50	75	75
2.	Lightweight concrete, not leaner than 1:2:4 mix (unplastered): concrete not assumed to be load bearing, reinforced ²⁾	25	25	25	40	60

¹⁾ So fixed or designed, as to allow full penetration for mechanical bond.

²⁾ Reinforcement shall consist of steel binding wire not less than 2.3 mm in thickness, or a steel mesh weighing not less than 0.5 kg/m². In concrete protection, the spacing of that reinforcement shall not exceed 200 mm in any direction.

Table 15 Encased Steel Beams, 406 mm × 176 mm (Protection Applied on Three Sides)

(Clause 3.3.2)

Nature of Construction and Materials (1)	Minimum Thickness (mm) of Protection for a Fire Resistance of					
	½ h (2)	1 h (3)	1½ h (4)	2 h (5)	3 h (6)	4 h (7)
A) Hollow protection (without an air cavity beneath the lower flange):						
1. ¹⁾ Metal lathing with trowelled lightweight aggregate gypsum plaster	13	13	15	20	25	
2. Plasterboard with 1.6 mm wire binding ²⁾ at 100 mm pitch, finished with lightweight aggregate gypsum plaster not less than the thickness specified:						
a) 9.5 mm plaster board	10	10	15			
b) 19 mm plaster board	10	10		13	20	
3. Asbestos insulating boards, thickness of board:						
a) Single thickness of board, with 6 mm cover fillets at transverse joints			19	25		
b) Two layers, of total thickness					38	50
B) Hollow protection (with an air cavity below the lower flange):						
1. Asbestos insulating board screwed to 25 mm asbestos battens	9	12				
C) Solid protection:						
1. Concrete, not leaner than 1:2:4 mix (unplastered):						
a) Concrete not assumed to be load bearing, reinforced ³⁾	25	25	25	25	50	75
b) Concrete assumed to be load bearing	50	50	50	50	75	75
2. Lightweight concrete ⁴⁾ , not leaner than 1:2:4 (mix) unplastered	25	25	25	25	40	60

¹⁾ So fixed or designed, as to allow full penetration for mechanical bond.

²⁾ Where wire binding cannot be used, expert advice should be sought regarding alternative methods of support to enable the lower edges of the plasterboard to be fixed together and to the lower flange, and for the top edge of the plasterboard to be held in position.

³⁾ Reinforcement shall consist of steel binding wire not less than 2.3 mm in thickness or a steel mesh weighing not less than 0.5 kg/m². In concrete protection, the spacing of that reinforcement shall not exceed 200 mm in any direction.

⁴⁾ Concrete not assumed to be load bearing, reinforced.

Table 16 Timber Floors — Tongued and Grooved Boarding, or Sheets of Tongued and Grooved Plywood or Wood Chipboard, of not Less than 21 mm Finished Thickness

(Clause 3.3.2)

Nature of Construction and Materials (1)	Minimum Thickness (mm) of Protection for a Fire Resistance of		
	½ h (2)	1 h (3)	2 h (4)
37 mm (minimum) timber joists with a ceiling of:			
1. Timber lathing and plaster, plaster of thickness	15		
2. Metal lathing and plaster, thickness of plaster:			
a) Sanded gypsum plaster (metal lathing grade)	15		
b) Lightweight aggregate gypsum plaster	13	13	25
3. One layer of plasterboard with taped and filled joints	12.7		
4. Two layers of plasterboard with joints staggered, joints in outer layer taped and filled total thickness	19	31	
5. One layer of plasterboard not less than 9.5 mm thick, finished with:			
a) Gypsum plaster	5		
b) Sanded gypsum plaster	13		
c) Lightweight aggregate gypsum plaster	13		
6. One layer of plasterboard not less than 12.7 mm thick, finished with:			
a) Gypsum plaster	5		
b) Lightweight aggregate gypsum plaster	10		
7. One layer of asbestos insulating board with any transverse joints backed by fillets of asbestos insulating board not less than 9 mm thick, or by timber	9	12	

Table 17 Timber Floors — Tongued and Grooved Boarding, or Sheets of Tongued and Grooved Plywood or Wood Chipboard, of not Less than 15 mm Finished Thickness

(Clause 3.3.2)

Nature of Construction and Materials (1)	Minimum Thickness (mm) of Protection for a Fire Resistance of		
	1½ h (2)	1 h (3)	2 h (4)
37 mm (minimum) timber joists with a ceiling of:			
1. Timber lathing and plaster, plaster of thickness	15		
2. Metal lathing and plaster, thickness of plaster for:			
a) Sanded gypsum plaster (metal lathing grade)	15		
b) Lightweight aggregate gypsum plaster	13	13	25
3. One layer of plasterboard with taped and filled joints	12.7		
4. Two layers of plasterboard with joints staggered, joints in outer layer taped and filled total thickness	22	31	
5. One layer of plasterboard not less than 9.5 mm thick, finish with:			
a) Gypsum plaster	5		
b) Sanded gypsum plaster	15		
c) Lightweight aggregate gypsum plaster	13		
6. One layer of plasterboard not less than 12.7 mm thick, finished with:			
a) Gypsum plaster	5		
b) Lightweight aggregate gypsum plaster	10		
7. One layer of asbestos insulating board, with any transverse joints backed by fillets of asbestos insulating board not less than 9 mm thick, or by timber	9	12 ¹⁾	

¹⁾ Finished on top with 25 mm minimum thick glass fibre or mineral wool laid between joints.

Table 18 Timber Floors — Any Structurally Suitable Flooring of Timber or Lignocelluloses Boards

(Clause 3.3.2)

Nature of Construction and Materials (1)	Minimum Thickness (mm) of Protection for a Fire Resistance of	
	½ h (2)	1 h (3)
37 mm (minimum) timber joists with a ceiling of:		
1. Timber lathing and plaster, plaster of thickness	15	
2. Metal lathing and plaster, thickness of plaster for:		
a) Sanded gypsum plaster (metal lathing grade)	15	
b) Lightweight aggregate gypsum plaster	13	19
3. One layer of plasterboard with joints taped and filled and backed by timber	12.7	
4. Two layers of plasterboard with joints staggered, joints in outer layer taped and filled total thickness	25	
5. Two layers of plasterboard, each not less than 9.5 mm thick, joints between boards staggered and outer layer finished with gypsum plaster	5	
6. One layer of plasterboard not less than 9.5 mm thick, finish with:		
a) Sanded gypsum plaster	13	
b) Lightweight aggregate gypsum plaster	15	
7. One layer of plasterboard not less than 12.7 mm thick, finished with:		
a) Sanded gypsum plaster	15	
b) Lightweight aggregate gypsum plaster	13	
8. One layer of asbestos insulating board with any transverse joints backed by fillets of asbestos insulating board not less than 9 mm thick, or by timber	12	

3.3.3 Steel Construction

Load bearing steel beams and columns of buildings having total covered area of 500 m² and above shall be protected against failure/collapse of structure in case

of fire. This could be achieved by use of appropriate methodology using suitable fire resistance rated materials alongwith suppression system {see Table 14, Table 15 and also accepted standard [4(5)]}.

3.4 General Requirements of All Individual Occupancies

3.4.1 General

All buildings shall satisfy certain requirements which contribute, individually and collectively, to the safety of life from fire, smoke, fumes and panic arising from these or similar causes. There are, however, certain general principles and common requirements which are applicable to all or most of the occupancies.

3.4.2 Exceptions and Deviations

Exceptions and deviations to the general provisions of requirements of individual occupancies are given as applicable to each type of occupancy in 6.1 to 6.9. In case of practical difficulty or to avoid unnecessary hardship, without sacrificing reasonable safety, the Authority may grant exemptions from the Code.

3.4.3 Occupation of Buildings under Construction

3.4.3.1 A building or portion of the building may be occupied during construction, repairs, alterations or additions only if all means of exit and fire protection measures are in place and continuously maintained for the occupied part of the building.

3.4.3.2 A high rise building during construction shall be provided with the following fire protection measures, which shall be maintained in good working condition at all the times:

- a) Dry riser of minimum 100 mm diameter pipe with hydrant outlets on the floors constructed with a fire service inlet to boost the water in the dry riser and maintenance should be as per the requirements laid down in good practice [4(6)].
- b) Drums filled with water of 2 000 litres capacity with two fire buckets on each floor; and
- c) A water storage tank of minimum 20 000 litres capacity, which may be used for other construction purposes also.

3.4.4 Maximum Height

Every building shall be restricted in its height above the ground level and the number of storeys, depending upon its occupancy and the type of construction. The height shall be measured as specified in Part 3 'Development Control Rules and General Building Requirements'. The maximum permissible height for any combination of occupancy and types of construction should necessarily be related to the width of street fronting the building, or floor area ratios and the local fire fighting facilities available.

3.4.5 Floor Area Ratio

The comparative floor area ratios for different occupancies and types of construction are given in

Table 19 (*see also* Part 3 'Development Control Rules and General Building Requirements').

Table 19 Comparative Floor Area Ratios for Occupancies Facing One Public Street Atleast 9 m Wide
(Clauses 2.6 and 3.4.5)

Occupancy Classification	Type of Construction			
	Type 1	Type 2	Type 3	Type 4
(1)	(2)	(3)	(4)	(5)
Residential	UL	2.0	1.4	1.0
Educational	UL	2.0	1.4	1.0
Institutional	UL	1.5	1.0	0.8
Assembly	UL	1.0	0.7	0.5
Business	UL	2.9	2.3	1.6
Mercantile	8.0	1.8	1.4	1.0
Industrial	7.5	1.9	1.6	1.3
Storage (<i>see</i> Note 5)	6.0	1.5	1.3	1.0
Hazardous (<i>see</i> Note 5)	2.8	1.1	0.9	NP

UL — Unlimited.

NP — Not permitted.

NOTES

1 The FAR values given in this table are subject to overall restrictions on the heights of buildings in the case of educational, institutional, assembly, storage and hazardous occupancies as specified in col 2 of Table 23.

2 This table has been prepared, taking into account the combustible content in the different occupancies as well as the fire resistance offered by the type of construction.

3 This table should be modified by the Authority, taking into account the other aspects as given below:

- a) Density in terms of dwelling units per hectare;
- b) Traffic considerations;
- c) Parking spaces;
- d) Local fire fighting facilities; and
- e) Water supply, drainage and sanitation requirements.

4 The FAR values specified in this table may be increased by 20 percent for the following services:

- a) A basement or cellar space under a building constructed on stilts and used as a parking space and air-conditioning plant room used as accessory to the principal use;
- b) Watchman's booth, pumphouse, garbage shaft, electric cabin or sub-station and other utility structures meant for the services of the building under considerations;
- c) Projections and accessory buildings as specifically exempted under the Code; and
- d) Staircase room and lift rooms above the topmost storey; architectural feature; and chimneys and elevated tanks of dimensions as permissible under the Code; the area of the lift shaft shall be taken only on one floor.

5 In so far as single storey storage and hazardous occupancies are concerned, they would be further governed by volume to plot area ratio (VPR) to be decided by the Authority.

3.4.5.1 Each portion of a building, which is separated by one or more continuous fire resisting walls, having a fire resistance of not less than 2 h, extending from the foundation to 1 m above the roof at all points, may

be considered to be a separate building for the calculation of maximum permissible height and floor area, provided openings, if any, in the separating wall are also protected by fire assemblies of not less than 2 h.

3.4.6 Open Spaces

The open spaces around or inside a building shall conform to the requirements of Part 3 'Development Control Rules and General Building Requirements'.

3.4.6.1 For high rise buildings, the following additional provisions of means of access to the building shall be ensured (*see* Part 3 'Development Control Rules and General Building Requirements'):

- a) The width of the main street on which the building abuts shall not be less than 12 m and one end of this street shall join another street not less than 12 m in width;
- b) The road shall not terminate in a dead end; except in the case of residential building, up to a height of 30 m.
- c) The compulsory open spaces around the building shall not be used for parking; and
- d) Adequate passageway and clearances required for fire fighting vehicles to enter the premises shall be provided at the main entrance; the width of such entrance shall be not less than 4.5 m. If an arch or covered gate is constructed, it shall have a clear head-room of not less than 5 m.

3.4.7 Mixed Occupancy

When any building is used for more than one type of occupancy, then in so far as fire safety is concerned, it shall conform to the requirements for the occupancies of higher hazard. Unless the high hazard area is separated by separating walls of 4 h rating, the occupancies shall not be treated individually.

3.4.8 Openings in Separating Walls and Floors

At the time of designing openings in separating walls and floors, particular attention shall be paid to all such factors as will limit fire spread through these openings and maintain fire rating of the structural member.

3.4.8.1 For Types 1 to 3 construction, a doorway or opening in a separating wall on any floor shall be limited to 5.6 m² in area with a maximum height/width of 2.75 m. Every wall opening shall be protected with fire-resisting doors having the fire rating of not less than 2 h in accordance with accepted standard [4(7)]. All openings in the floors shall be protected by vertical enclosures extending above and below such openings, the walls of such enclosures having a fire resistance of not less than 2 h and all openings therein being

protected with a fire-resisting assembly as specified in 3.4.9.

3.4.8.2 For Type 4 construction, openings in the separating walls or floors shall be fitted with 2 h fire-resisting assemblies.

3.4.8.3 Openings in walls or floors which are necessary to be provided to allow passages of all building services like cables, electrical wirings, telephone cables, plumbing pipes, etc, shall be protected by enclosure in the form of ducts/shafts having a fire resistance not less than 2 h. The inspection door for electrical shafts/ducts shall be not less than 2 h and for other services shafts/ducts, the same shall have fire resistance not less than 1 h. Medium and low voltage wiring running in shafts/ducts, shall either be armoured type or run through metal conduits. Further, the space between the conduits pipes and the walls/slabs shall be filled in by a filler material having fire resistance rating of not less than 1 h.

NOTE — In the case of buildings where it is necessary to lower or lift heavy machinery or goods from one floor to the other, it may be necessary to provide larger openings in the floor. Such openings shall be provided with removable covers which shall have the same strength and fire resistance as the floor.

3.4.8.4 Vertical opening

Every vertical opening between the floors of a building shall be suitably enclosed or protected, as necessary, to provide the following:

- a) Reasonable safety to the occupants while using the means of egress by preventing spread of fire, smoke, or fumes through vertical openings from floor to floor to allow occupants to complete their use of the means of egress. Further it shall be ensured to provide a clear height of 2 100 mm in the passage/escape path of the occupants.
- b) Limitation of damage to the building and its contents.

3.4.9 Fire Stop or Enclosure of Openings

Where openings are permitted, they shall not exceed three-fourths the area of the wall in the case of an external wall and they shall be protected with fire resisting assemblies or enclosures having a fire resistance equal to that of the wall or floor in which these are situated. Such assemblies and enclosures shall also be capable of preventing the spread of smoke or fumes through the openings so as to facilitate the safe evacuation of building in case of a fire {*see also* accepted standard [4(8)]}.

3.4.10 Electrical Installations

For requirements regarding electrical installations from the point of view of fire safety, reference may be made

to good practice [4(9)] (*see also* Part 8 'Building Services, Section 2 Electrical and Allied Installations').

3.4.11 Air-conditioning and Ventilation

Air-conditioning and ventilation requirements of different rooms or areas in any occupancy shall be as given in Part 8 'Building Services, Section 1 Lighting and Ventilation and Section 3 Air-conditioning, Heating and Mechanical Ventilation'.

3.4.11.1 Air-conditioning and ventilating systems shall be so installed and maintained as to minimize the danger of spread of fire, smoke or fumes from one floor to other or from outside to any occupied building or structure (*see C-1.17*).

3.4.11.2 Air-conditioning and ventilating systems circulating air to more than one floor or fire area shall be provided with dampers designed to close automatically in case of fire and thereby preventing spread of fire or smoke and shall be in accordance with the accepted standard [4(10)]. Such a system shall also be provided with automatic controls to stop fans in case of fire, unless arranged to remove smoke from a fire, in which case these shall be designed to remain in operation.

3.4.11.3 Air-conditioning system serving large places of assembly (over 1 000 persons), large departmental stores or hotels with over 100 rooms in a single block shall be provided with effective means for preventing circulation of smoke through the system in the case of a fire in air filters or from other sources drawn into the system, and shall have smoke sensitive devices for actuation in accordance with the accepted standards [4(11)].

3.4.11.4 From fire safety point of view, separate air handling units for the various floors shall be provided so as to avoid the hazards arising from spread of fire and smoke through the air-conditioning ducts. The requirements of air-conditioning ducts shall be in accordance with good practice [4(12)].

3.4.11.5 For normal operation, air changes schedule shall be as given in Part 8 'Building Services, Section 3 Air-conditioning, Heating and Mechanical Ventilation'.

3.4.12 Smoke Venting

3.4.12.1 Smoke venting facilities for safe use of exits in windowless buildings, underground structures, large area factories, hotels and assembly buildings (including cinema halls) shall be automatic in action with manual controls in addition.

3.4.12.2 Natural draft smoke venting shall utilize roof vents or vents in walls at or near the ceiling level; such vents shall be normally open, or, if closed, shall be designed for automatic opening in case of fire, by release of smoke sensitive devices.

3.4.12.3 Where smoke venting facilities are installed for purposes of exit safety, these shall be adequate to prevent dangerous accumulation of smoke during the period of time necessary to evacuate the area served, using available exit facilities with a margin of safety to allow for unforeseen contingencies. It is recommended that smoke exhaust equipment should have a minimum capacity of 12 air changes per hour. Where mechanical venting is employed, it shall be firesafe.

3.4.12.4 The discharge apertures of all natural draft smoke vents shall be so arranged as to be readily accessible for opening by fire service personnel.

3.4.12.5 Power operated smoke exhausting systems shall be substituted for natural draft vents only by specific permission of the Authority.

3.4.13 Heating

Installation of chimney and heating apparatus shall be in accordance with good practice [4(13)].

3.4.14 Additional Precautions

In addition to the factors covered by **3.4.2** to **3.4.12** there are certain aspects, applicable to particular occupancies only, which may effect the spread of fumes and thus the safe evacuation of the building in case of fire. Some such aspects are:

- a) interior finish and decoration;
- b) seating, aisles, railings, turnstiles and revolving doors in places of assembly;
- c) service equipment and storage facilities in buildings other than storage buildings; and
- d) hazards on stage, in waiting spaces, projection booths, etc, in theatres and cinemas.

3.4.15 Surface Interior Finishes

3.4.15.1 The use of combustible surface finishes on walls (including facade of the building) and ceilings affects the safety of the occupants of a building. Such finishes tend to spread the fire and even though the structural elements may be adequately fire resistant, serious danger to life may result. It is, therefore, essential to have adequate precautions to minimize spread of flame on wall, facade of building and ceiling surfaces.

The finishing materials used for various surfaces and décor shall be such that it shall not generate toxic smoke/fumes.

3.4.15.2 The susceptibility to fire of various types of wall surfaces is determined in terms of the rate of spread of flame. Based on the rate of spread of flame, surfacing material shall be considered as divided into four classes as follows {*see also* good practice [4(14)]}.

Class 1 Surfaces of very low flame spread.

Class 2 Surfaces of low flame spread.

Class 3 Surfaces of medium flame spread.

Class 4 Surfaces of rapid flame spread.

3.4.15.3 The uses for which surface materials falling into various classes shall be adopted in building construction are given below:

Class 1	Class 2	Class 3
May be used in any situation	May be used in any situation, except on walls, facade of the building, staircase and corridors	May be used only in living rooms and bed rooms (but not in rooms on the roof) and only as a lining to solid walls and partitions; not on staircases or corridors or facade of the building.

NOTE — Panelling (lining) shall be permitted in a limited area. It shall not be permitted in a vestibule.

3.4.15.4 Materials of Class 4 which include untreated wood fibreboards may be used with due fire retardant treatment as ceiling lining, provided the ceiling is at least, 2.4 m from the top surface of the floor below, and the wall surfaces conform to requirements of class [see Note under **3.4.15.3**] Class 4 materials shall not be used in kitchens, corridors and staircases. Some materials contain bitumen and, in addition to risk from spread of fire, emit dense smoke on burning; such materials shall be excluded from use under these conditions and shall also not be used for construction of ceiling where the plenum is used for return air in air-conditioned buildings [see also **5.1.7(m)**].

3.4.15.5 When frames, walls, partitions or floors are lined with combustible materials, the surfaces on both sides of the materials shall conform to the appropriate class, because there is considerable danger from fire starting and rapidly spreading within the concealed cavity unknown to the occupants whose escape may be hampered there by. For detailed information on materials and details of construction with their fire-resistance rating, reference may be made to good practice [4(15)].

3.4.16 Glazing

3.4.16.1 Building of Types 1 to 4 construction shall employ one of the two types of glazing described in **3.4.16.2** and **3.4.16.3** except that Type 4 construction may have the alternative of hardwood sashes or frames or both.

3.4.16.2 Wired glass shall comply with the following requirements:

- a) *Wired glass* — The wired glass shall be of minimum half hour fire resistance rating.
- b) *Sashes and frames* — The sashes or frames or both shall be entirely of iron or other suitable metal such as stainless steel, securely bolted or keyed into the wall, except in the case of panels in internal doors.
- c) *Setting of glass* — The panels of glass shall be set in rebates or grooves not less than 6.0 mm in width or depth, with due allowance for expansion, and shall be secured by hard metal fastenings to the sashes or frames independently of any cement or putty used for weather-proofing purposes.

3.4.16.3 Electro-copper glazing shall comply with the following requirements:

- a) *Electro-copper glazing* — The electro-copper glazing shall be of minimum half hour fire resistance rating.
- b) *Sashes and frames* — The sashes or frames or both shall be entirely of iron or other hard metal, securely bolted or keyed into the wall, except when in panels in internal doors.
- c) *Fixing of sectional lights* — The sectional lights shall be set in rebate or grooves not less than 6.5 mm in width or depth, with due allowance for expansion and shall be secured by hard metal fastenings to the sashes or frames independently of any lead, cement or putty used for weather-proofing purposes.

3.4.16.4 Maximum permissible area shall be 5 m² for protection by wired glass or electro-copper glazing.

3.4.16.5 Casement

Hard metal casements, not exceeding 0.8 m² fitted with wired glass or electro-copper glazing in accordance with **3.4.16.2** and **3.4.16.3**, secured to the frames by hard metal hinges not more than 600 mm apart and by fastening at top, centre and bottom shall be permissible.

3.4.17 Skylights

3.4.17.1 Wired glass for skylights or monitor lights shall comply with the following requirements:

- a) *Wired glass for skylights or monitor lights* — The wired glass for skylights or monitor lights shall be of minimum half hour fire resistance rating.
- b) *Frames and glazing* — The frame shall be continuous and divided by bars spaced at not more than 700 mm centres. The frame and bars shall be of iron or other hard metal, and supported on a curb either of metal or of wood covered with sheet metal. The toughened glass

shall be secured by hard metal fastenings to the frame and bars independently of any lead, cement or putty used for weather-proofing purposes.

3.4.18 Louvers

Louvers wherever provided shall be of minimum half hour fire resistance rating.

3.4.19 Glass of facade for high rise buildings, etc shall be of minimum 1 h fire resistance rating.

4 LIFE SAFETY

4.1 General

Every building shall be so constructed, equipped, maintained and operated as to avoid undue danger to the life and safety of the occupants from fire, smoke, fumes or panic during the time period necessary for escape.

4.2 General Exit Requirements

4.2.1 An exit may be a doorway; corridor; passageway(s) to an internal staircase, or external staircase, or to a *VERANDAH* or terrace(s), which have access to the street, or to the roof of a building or a refuge area. An exit may also include a horizontal exit leading to an adjoining building at the same level.

4.2.2 Lifts and escalators shall not be considered as exits.

4.2.3 Every exit, exit access or exit discharge shall be continuously maintained free of all obstructions or impediments to full use in the case of fire or other emergency.

4.2.4 Every building meant for human occupancy shall be provided with exits sufficient to permit safe escape of occupants, in case of fire or other emergency.

4.2.5 In every building or structure, exits shall comply with the minimum requirements of this part, except those not accessible for general public use.

4.2.6 No building shall be so altered as to reduce the number, width or protection of exits to less than that required.

4.2.7 Exits shall be clearly visible and the route to reach the exits shall be clearly marked and signs posted to guide the occupants of the floor concerned. Signs shall be illuminated and wired to an independent electrical circuit on an alternative source of supply. The sizes and colours of the exit signs shall be in accordance with good practice [4(16)]. The colour of the exit signs shall be green.

NOTE — This provision shall not apply to A-2 and A-4 occupancies less than 15 m in height.

4.2.8 The floors of areas covered for the means of exit shall be illuminated to values not less than 1 ft candle (10 lux) at floor level. In auditoriums, theatres, concert halls and such other places of assembly, the illumination of floor exit/access may be reduced during period of performances to values not less than 1/5 ft candle (2 lux).

4.2.9 Fire doors with 2 h fire resistance shall be provided at appropriate places along the escape route and particularly at the entrance to lift lobby and stair well where a 'funnel or flue effect' may be created, inducing an upward spread of fire to prevent spread of fire and smoke.

4.2.10 All exits shall provide continuous means of egress to the exterior of a building or to an exterior open space leading to a street.

4.2.11 Exits shall be so arranged that they may be reached without passing through another occupied unit.

4.3 Occupant Load

For determining the exits required, the number of persons within any floor area or the occupant load shall be based on the actual number of occupants, but in no case less than that specified in Table 20.

4.3.1 Mezzanine

The occupant load of a mezzanine floor discharging to a floor below shall be added to that floor occupancy and the capacity of the exits shall be designed for the total occupancy load thus established.

4.4 Capacities of Exits

4.4.1 The unit of exit width, used to measure the capacity of any exit, shall be 500 mm. A clear width of 250 mm shall be counted as an additional half unit. Clear widths less than 250 mm shall not be counted for exit width.

NOTE — The total occupants from a particular floor must evacuate within 2½ minutes for Type 1 construction, 1½ minutes for Type 2 construction and 1 minute for Type 3 construction. Size of the exit door/exitway shall be calculated accordingly keeping in view the travel distance as per Table 22.

4.4.2 Occupants per unit exit width shall be in accordance with Table 21.

4.4.3 Horizontal Exit Allowance

When horizontal exit is provided in buildings of mercantile, storage, industrial, business and assembly occupancies, the capacity per storey per unit width of exit of stairways in Table 21 may be increased by 50 percent and in buildings of institutional occupancy it may be increased by 100 percent.

Table 20 Occupant Load
(Clause 4.3)

Sl No.	Group of Occupancy	Occupant Load, Floor Area in m ² /Person
(1)	(2)	(3)
i)	Residential (A)	12.5
ii)	Educational (B)	4
iii)	Institutional (C)	15 (see Note 1)
iv)	Assembly (D)	
	a) With fixed or loose seats and dance floors	0.6 (see Note 2)
	b) Without seating facilities including dining rooms	1.5 (see Note 2)
v)	Mercantile (F)	
	a) Street floor and sales basement	3
	b) Upper sale floors	6
vi)	Business and industrial (E&G)	10
vii)	Storage (H)	30
viii)	Hazardous (J)	10

NOTES

1 Occupant load in dormitory portions of homes for the aged, orphanages, insane asylums, etc, where sleeping accommodation is provided, shall be calculated at not less than 7.5 m² gross floor area/person.

2 The gross floor area shall include, in addition to the main assembly room or space, any occupied connecting room or space in the same storey or in the storeys above or below, where entrance is common to such rooms and spaces and they are available for use by the occupants of the assembly place. No deductions shall be made in the gross area for corridors, closets or other sub-divisions; the area shall include all space serving the particular assembly occupancy.

Table 21 Occupants per Unit Exit Width
(Clauses 4.4.2, 4.4.3 and C-1.6.2)

Sl No.	Group of Occupancy	Number of Occupants		
		Stairways	Ramps	Doors
(1)	(2)	(3)	(4)	(5)
i)	Residential (A)	25	50	75
ii)	Educational (B)	25	50	75
iii)	Institutional (C)	25	50	75
iv)	Assembly (D)	40	50	60
v)	Business (E)	50	60	75
vi)	Mercantile (F)	50	60	75
vii)	Industrial (G)	50	60	75
viii)	Storage (H)	50	60	75
ix)	Hazardous (J)	25	30	40

4.5 Arrangement of Exits

4.5.1 Exits shall be so located that the travel distance on the floor shall not exceed the distance given in Table 22.

4.5.2 The travel distance to an exit from the dead end of a corridor shall not exceed half the distance specified

in Table 22, except in assembly and institutional occupancies in which case it shall not exceed 6 m.

4.5.3 Whenever more than one exit is required for any room space or floor of a building, exits shall be placed as remote from each other as possible and shall be arranged to provide direct access in separate directions from any point in the area served.

Table 22 Travel Distance for Occupancy and Type of Construction
(Clauses 4.4.1, 4.5.1 and 4.5.2)

Sl No.	Group of Occupancy	Maximum Travel Distance Construction	
		Types 1 & 2 m	Types 3 & 4 m
(1)	(2)	(3)	(4)
i)	Residential (A)	30.0	22.5
ii)	Educational (B)	30.0	22.5
iii)	Institutional (C)	30.0	22.5
iv)	Assembly (D)	30.0	30.0
v)	Business (E)	30.0	30.0
vi)	Mercantile (F)	30.0	30.0
vii)	Industrial (G)	45.0	¹⁾
viii)	Storage (H)	30.0	¹⁾
ix)	Hazardous (J)	22.5	¹⁾

NOTES

1 For fully sprinklered building, the travel distance may be increased by 50 percent of the values specified.

2 Ramps shall be protected with automatic sprinkler system and shall be counted as one of the means of escape.

¹⁾ Construction of type 3 or 4 is not permitted.

4.6 Number of Exits

4.6.1 General

The general requirements of number of exits shall supplement the requirement of different occupancies in 6.1 to 6.9.

4.6.2 All buildings, which are 15 m in height or above, and all buildings used as educational, assembly, institutional, industrial, storage, and hazardous occupancies and mixed occupancies with any of the aforesaid occupancies, having area more than 500 m² on each floor shall have a minimum of two staircases. They shall be of enclosed type; at least one of them shall be on external walls of buildings and shall open directly to the exterior, interior open space or to an open place of safety. Further, the provision or otherwise of alternative staircases shall be subject to the requirements of travel distance being complied with.

4.7 Doorways

4.7.1 Every exit doorway shall open into an enclosed stairway or a horizontal exit of a corridor or passageway providing continuous and protected means of egress.

4.7.2 No exit doorway shall be less than 1 000 mm in width except assembly buildings where door width shall be not less than 2 000 mm. Doorways shall be not less than 2 000 mm in height.

4.7.3 Exit doorways shall open outwards, that is, away from the room, but shall not obstruct the travel along any exit. No door, when opened, shall reduce the required width of stairway or landing to less than 900 mm; overhead or sliding doors shall not be installed.

NOTE — In the case of buildings where there is a central corridor, the doors of rooms shall open inwards to permit smooth flow of traffic in the corridor.

4.7.4 Exit door shall not open immediately upon a flight of stairs; a landing equal to at least the width of the door shall be provided in the stairway at each doorway; the level of landing shall be the same as that of the floor which it serves.

4.7.5 Exit doorways shall be openable from the side which they serve without the use of a key.

4.7.6 Mirrors shall not be placed in exit ways or exit doors to avoid confusion regarding the direction of exit.

4.8 Corridors and Passageways

4.8.1 Exit corridors and passageways shall be of width not less than the aggregate required width of exit doorways leading from them in the direction of travel to the exterior.

4.8.2 Where stairways discharge through corridors and passageways, the height of corridors and passageways shall be not less than 2.4 m.

4.8.3 All means of exit including staircases lifts lobbies and corridors shall be adequately ventilated.

4.9 Internal Staircases

4.9.1 Internal stairs shall be constructed of non-combustible materials throughout.

4.9.2 Internal stairs shall be constructed as a self-contained unit with an external wall of the building constituting at least one of its sides and shall be completely enclosed.

4.9.3 A staircase shall not be arranged round a lift shaft.

4.9.4 Hollow combustible construction shall not be permitted.

4.9.5 No gas piping or electrical panels shall be allowed in the stairway. Ducting in stairway may be permitted if it is of 1 h fire resistance rating.

4.9.6 Notwithstanding the detailed provision for exits in accordance with 4.3, 4.4 and 4.5, the following minimum width shall be provided for staircases:

a) Residential buildings (dwellings)	1.0 m
b) Residential hotel buildings	1.5 m
c) Assembly buildings like auditorium, theatres and cinemas	2.0 m
d) Educational buildings up to 30 m in height	1.5 m
e) Institutional buildings like hospitals	2.0 m
f) All other buildings	1.5 m

4.9.7 The minimum width of tread without nosing shall be 250 mm for internal staircase of residential buildings. This shall be 300 mm for assembly, hotels, educational, institutional, business and other buildings. The treads shall be constructed and maintained in a manner to prevent slipping.

4.9.8 The maximum height of riser shall be 190 mm for residential buildings and 150 mm for other buildings and the number shall be limited to 15 per flight.

4.9.9 Handrails shall be provided at a height of 1 000 mm to be measured from the base of the middle of the treads to the top of the handrails. Balusters/railing shall be provided such that the width of staircase does not reduce (*see* Fig. 1).

4.9.10 The number of people in between floor landings in staircase shall not be less than the population on each floor for the purpose of design of staircase. The design of staircase shall also take into account the following:

- The minimum headroom in a passage under the landing of a staircase and under the staircase shall be 2.2 m.
- For building 15 m in height or more, access to main staircase shall be through a fire/smoke check door of a minimum 2 h fire resistance rating. Fire resistance rating may be reduced to 1 h for residential buildings (except hotels and starred hotels).
- No living space, store or other fire risk shall open directly into the staircase or staircases.
- External exit door of staircase enclosure at ground level shall open directly to the open spaces or through a large lobby, if necessary.
- The main and external staircases shall be continuous from ground floor to the terrace level.
- No electrical shafts/AC ducts or gas pipes, etc, shall pass through or open in the staircases. Lifts shall not open in staircase.
- No combustible material shall be used for decoration/wall paneling in the staircase.
- Beams/columns and other building features shall not reduce the head room/width of the staircase.

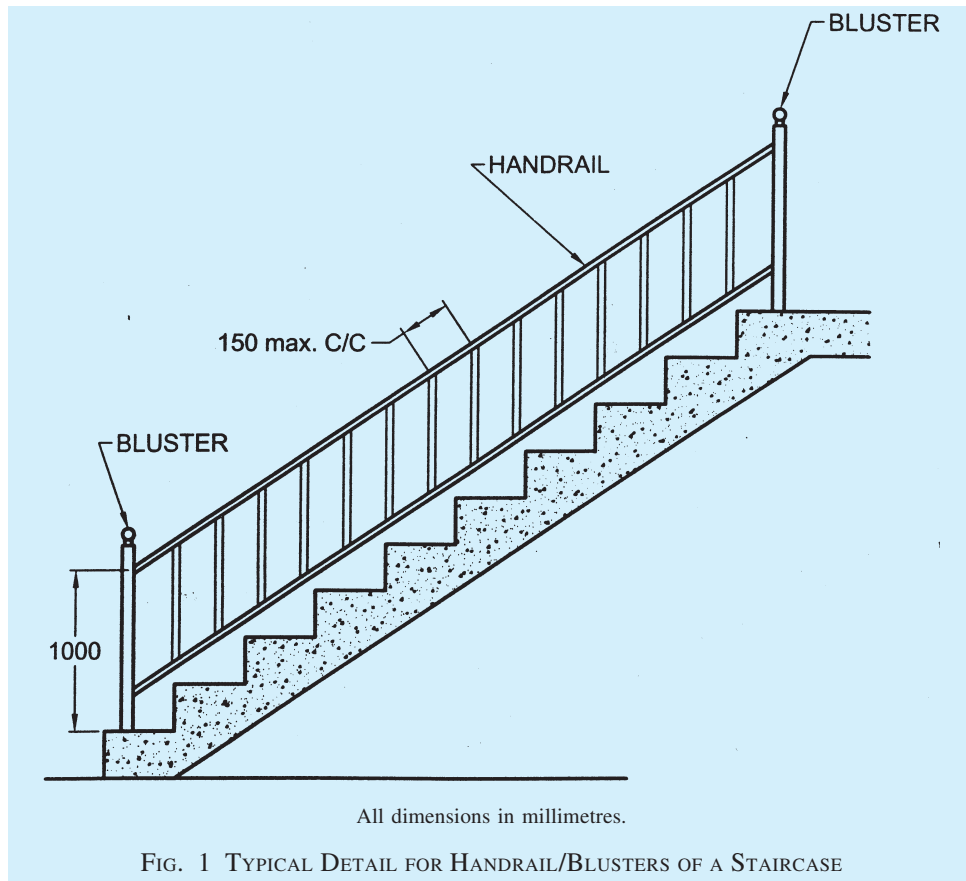

- j) The exit sign with arrow indicating the way to the escape route shall be provided at a suitable height from the floor level on the wall and shall be illuminated by electric light connected to corridor circuits. All exit way marking signs should be flush with the wall and so designed that no mechanical damage shall occur to them due to moving of furniture or other heavy equipments. Further, all landings of floor shall have floor indicating boards prominently indicating the number of floor as per bye-laws.

The floor indication board shall be placed on the wall immediately facing the flight of stairs and nearest to the landing. It shall be of size not less than 0.5 m × 0.5 m.

- k) Individual floors shall be prominently indicated on the wall facing the staircases.
- m) In case of single staircase it shall terminate at the ground floor level and the access to the basement shall be by a separate staircase. The second staircase may lead to basement levels provided the same is separate at ground level by ventilated lobby with discharge points to two different ends through enclosures.

4.10 Pressurization of Staircases (Protected Escape Routes)

4.10.1 Though in normal building design, compartmentation plays a vital part in limiting the spread of fire, smoke will readily spread to adjacent spaces through the various leakage openings in the compartment enclosure, such as cracks, openings around pipes ducts, airflow grills and doors, as perfect sealing of all these openings is not possible. It is smoke and toxic gases, rather than flame, that will initially obstruct the free movement of occupants of the building through the means of escape (escape routes). Hence the exclusion of smoke and toxic gases from the protected routes is of great importance.

4.10.2 Pressurization is a method adopted for protected escape routes against ingress of smoke, especially in high-rise buildings. In pressurization, air is injected into the staircases, lobbies or corridors, to raise their pressure slightly above the pressure in adjacent parts of the building. As a result, ingress of smoke or toxic gases into the escape routes will be prevented. The pressurization of staircases shall be adopted for high rise buildings and building having mixed occupancy/multiplexes having covered area more than 500 m².

4.10.3 The pressure difference for staircases shall be as under:

Building Height	Pressure Difference	
	Reduced Operation (Stage 1 of a 2-Stage System) (Pa)	Emergency Operation (Stage 2 of a 2-Stage System or Single Stage System) (Pa)
Less than 15 m	8	50
15 m or above	15	50

If possible, the same levels shall be used for lobbies and corridors, but levels slightly lower may be used for these spaces if desired. The difference in pressurization levels between staircase and lobbies (or corridors) shall not be greater than 5 Pa.

4.10.4 Pressurization system may be of two types:

- Single-stage, designed for operation only in the event of an emergency, and
- Two-stage, where normally a level of pressurization is maintained in the protected escape routes and an increased level of pressurization can be brought into operation in an emergency.

4.10.5 The normal air-conditioning system and the pressurization system shall be treated as an integral one, especially for a two-stage system. When the emergency pressurization is brought into action, the following changes in the normal air-conditioning system shall be effected:

- Any re-circulation of air shall be stopped and all exhaust air vented to atmosphere;
- Any air supply to the spaces/areas other than escape routes shall be stopped;
- The exhaust system may be continued provided:
 - the positions of the extraction grills permit a general air flow away from the protected escape route entry;
 - the construction of the ductwork and fans is such that, it will not be rendered inoperable by hot gases and smoke; and
 - there is no danger of spread of smoke to other floors by the path of the extraction system which can be ensured by keeping the extraction fans running.

4.10.6 The pressurization system can be interconnected with the automatic/manual fire alarm system for actuation.

4.10.7 It will be desirable to have all the staircases in a building pressurized, if pressurization system is to

be resorted to. The use of pressurized and naturally ventilated staircases in the same building may introduce difficulties and hence shall be avoided. Under no circumstances shall a pressurized staircase be connected by a corridor or lobby to an un-pressurized staircase. Wherever pressurized staircase is to be connected to un-pressurized area, the two areas shall be segregated.

4.11 External Stairs

An external staircase is desirable to be provided for high rise buildings.

External stairs, when provided shall comply the following:

4.11.1 External stairs shall always be kept in sound operable conditions.

4.11.2 All external stairs shall be directly connected to the ground.

4.11.3 Entrance to the external stairs shall be separate and remote from the internal staircase.

4.11.4 Care shall be taken to ensure that no wall opening or window opens on to or close to an external stairs.

4.11.5 The route to the external stairs shall be free of obstructions at all times.

4.11.6 The external stairs shall be constructed of non-combustible materials, and any doorway leading to it shall have the required fire resistance.

4.11.7 No external staircase, used as a fire escape, shall be inclined at an angle greater than 45° from the horizontal.

4.11.8 External stairs shall have straight flight not less than 1 250 mm wide with 250 mm treads and risers not more than 190 mm. The number of risers shall be limited to 15 per flight.

4.11.9 Handrails shall be of a height not less than 1 000 mm and not exceeding 1 200 mm. There shall be provisions of balusters with maximum gap of 150 mm.

4.11.10 The use of spiral staircase shall be limited to low occupant load and to a building not exceeding 9 m in height.

A spiral stair case shall be not less than 1 500 mm in diameter and shall be designed to give adequate headroom.

4.11.11 Unprotected steel frame staircase will not be accepted as means of escape. However, steel staircase in an enclosed fire rated compartment of 2 h will be accepted as means of escape.

4.12 Horizontal Exits

4.12.1 The width of horizontal exit shall be same as for the exit doorways.

4.12.2 A horizontal exit shall be equipped with at least one fire/smoke door of minimum 1 h fire resistance, of self-closing type. Further, it is required to have direct connectivity to the fire escape staircase for evacuation.

4.12.3 For buildings more than 24 m in height, refuge area of 15 m² or an area equivalent to 0.3 m² per person to accommodate the occupants of two consecutive floors, whichever is higher, shall be provided as under:

The refuge area shall be provided on the periphery of the floor or preferably on a cantilever projection and open to air at least on one side protected with suitable railings.

- a) *For floors above 24 m and Up to 39 m* — One refuge area on the floor immediately above 24 m.
- b) *For floors above 39 m* — One refuge area on the floor immediately above 39 m and so on after every 15 m. Refuge area provided in excess of the requirements shall be counted towards FAR.

NOTE — Residential flats in multi-storied building with balcony, need not be provided with refuge area, however flats without balcony shall provide refuge area as given above.

4.12.4 Where there is a difference in level between connected areas for horizontal exits, ramps, not more than 1 in 10 m slope shall be provided; steps shall not be used.

4.12.5 Doors in horizontal exits shall be openable at all times from both sides.

4.13 Fire Tower

Fire towers are the preferred type of escape route for storeyed buildings and these shall be considered as the safest route for escape. Their number, location and size shall depend on the building concerned, and its associated escape routes.

4.13.1 In high rise buildings with over 8 storeys or 24 m in height, at least one required means of egress shall preferably be a fire tower.

4.13.2 The fire towers shall be constructed of walls with a 2 h fire resistance rating without openings other than the exit doorways, with platforms, landings and balconies having the same fire-resistance rating.

4.14 Ramps

4.14.1 Ramps shall comply with all the applicable requirements for stairways regarding enclosure,

capacity and limiting dimensions except where specified in **6.1** to **6.9** for special uses and occupancies.

4.14.2 The slope of a ramp shall not exceed 1 in 10. In certain cases steeper slopes may be permitted but in no case greater than 1 in 8.

4.14.3 For all slopes exceeding 1 in 10 and wherever the use is such as to involve danger of slipping, the ramp shall be surfaced with approved non-slipping material.

4.15 Fire Lifts

4.15.1 Where applicable, fire lifts shall be provided with a minimum capacity for 8 passengers and fully automated with emergency switch on ground level. In general, buildings 15 m in height or above shall be provided with fire lifts.

4.15.2 In case of fire, only fireman shall operate the fire lift. In normal course, it may be used by other persons.

4.15.3 Each fire lift shall be equipped with suitable inter-communication equipment for communicating with the control room on the ground floor of the building.

4.15.4 The number and location of fire lifts in a building shall be decided after taking into consideration various factors like building population, floor area, compartmentation, etc.

4.16 Emergency and Escape Lighting

4.16.1 Emergency lighting shall be powered from a source independent of that supplying the normal lighting [*see* good practice [4(17)]].

Escape lighting shall be capable of:

- a) Indicating clearly and unambiguously the escape routes,
- b) Providing adequate illumination along such routes to allow safe movement of persons towards and through the exits,
- c) Ensuring that fire alarm call points and fire-fighting equipments provided along the escape routes can be readily located.

4.16.2 The horizontal luminance at floor level on the centreline of an escape route shall be not less than 10 lux. In addition, for escape routes up to 2 m wide, 50 percent of the route width shall be lit to a minimum of 5 lux.

4.16.3 The emergency lighting shall be provided to be put on within 1 s of the failure of the normal lighting supply.

4.16.4 Escape lighting luminaries should be sited to cover the following locations:

- a) Near each intersection of corridors,
- b) at each exit door,
- c) Near each change of direction in the escape route,
- d) Near each staircase so that each flight of stairs receives direct light,
- e) Near any other change of floor level,
- f) Outside each final exit and close to it,
- g) Near each fire alarm call point,
- h) Near fire-fighting equipment, and
- j) To illuminate exit and safety signs as required by the enforcing authority.

NOTE — For the purposes of this clause ‘near’ is normally considered to be within 2 m measured horizontally.

4.16.5 Emergency lighting systems shall be designed to ensure that a fault or failure in any one luminaire does not further reduce the effectiveness of the system.

4.16.6 The luminaires shall be mounted as low as possible, but at least 2 m above the floor level.

4.16.7 Signs are required at all exits, emergency exits and escape routes, which should comply with the graphic requirements of the relevant Indian Standards.

4.16.8 Emergency lighting luminaires and their fittings shall be of non-flammable type.

4.16.9 It is essential that the wiring and installation of the emergency lighting systems are of high quality so as to ensure their perfect serviceability at all times.

4.16.10 The emergency lighting system shall be capable of continuous operation for a minimum duration of 1 h and 30 m even for the smallest premises.

4.16.11 The emergency lighting system shall be well maintained by periodical inspections and tests so as to ensure their perfect serviceability at all times.

4.17 Illumination of Means of Exit

Staircase and corridor lights shall conform to the following:

- a) The staircase and corridor lighting shall be on separate circuits and shall be independently connected so that it could be operated by one switch installation on the ground floor easily accessible to fire fighting staff at any time irrespective of the position of the individual control of the light points, if any. It should be of miniature circuit breaker type of switch so as to avoid replacement of fuse in case of crisis;

- b) Staircase and corridor lighting shall also be connected to alternative supply. The alternative source of supply may be provided by battery continuously trickle charged from the electric mains; and
- c) Suitable arrangements shall be made by installing double throw switches to ensure that the lighting installed in the staircase and the corridor does not get connected to two sources of supply simultaneously. Double throw switch shall be installed in the service room for terminating the stand-by supply.

4.18 Fire Detection and Warning

In buildings of such size, arrangement or occupancy where a fire may not itself provide adequate warning to occupants, automatic fire detection and alarm facilities shall be provided, where necessary, to warn occupants early of the existence of fire, so that they may escape, and to facilitate the orderly conduct of fire exit drills.

4.18.1 The fire detection system shall be in accordance with accepted standards [4(18)]. Guidelines for selection of various types of fire detectors for different occupancies and their installation and maintenance shall be in accordance with [4(19)].

4.18.2 The requirements of fire detection and alarm systems are covered for each occupancy in Table 23 and under **6.1** to **6.9**; attention is also drawn to such requirements in case of high rise buildings (15 m or more in height) as given in Annex C.

5 FIRE PROTECTION

5.1 Fire Extinguishers/Fixed Fire Fighting Installations

5.1.1 All buildings depending upon the occupancy use and height shall be protected by fire extinguishers, wet riser, down-comer, automatic sprinkler installation, high/medium velocity water spray, foam, gaseous or dry powder system in accordance with the provisions of **5.1.2** to **5.1.9**.

5.1.2 These fire extinguishers/fixed installations shall be in accordance with accepted standards [4(20)]. The typical requirements of fire extinguishers/wet riser/down-comer installation and capacity of water storage tanks and fire pumps, etc shall be as specified in Table 23. The requirements regarding size of mains/risers shall be as given in Table 24. The typical arrangements of down-comer and wet riser installations are shown in Fig. 2 and Fig. 3. The wet riser shall be designed for zonal distribution ensuring that unduly high pressures are not developed in risers and hose-pipes.

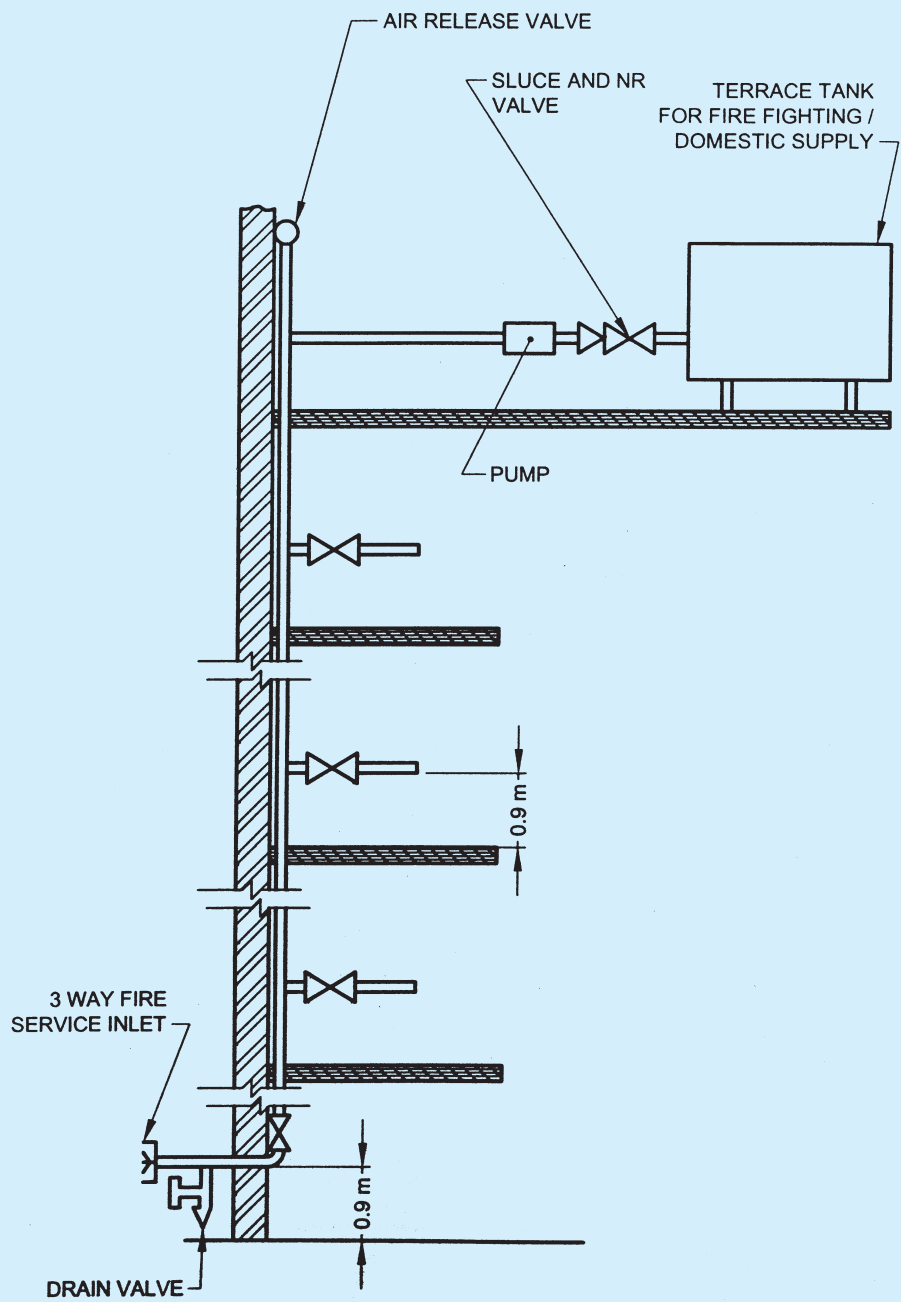

FIG. 2 TYPICAL ARRANGEMENT OF DOWN-COMER FOR BUILDING ABOVE 15 m BUT NOT EXCEEDING 30 m IN HEIGHT

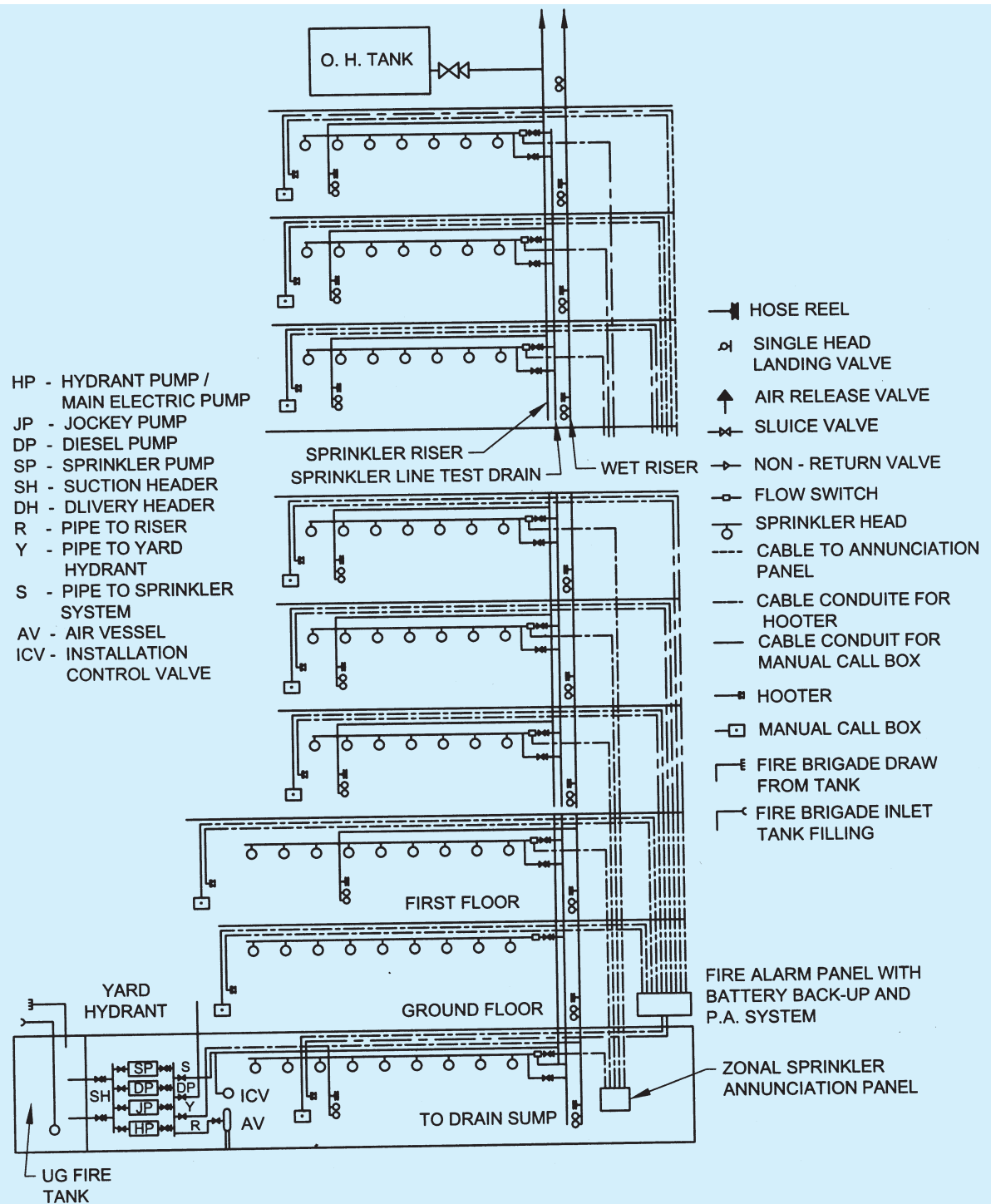

FIG. 3 TYPICAL ARRANGEMENT OF WET RISER AND TOTAL SPRINKLER SYSTEM OF BUILDING OTHER THAN APARTMENT EXCEEDING 30 m IN HEIGHT

Table 23 Minimum Requirements for Fire Fighting Installations

(Clauses 4.18.2, 6.1.2, 6.2.3, 6.3.2, 6.4.3, 6.5.2, 6.5.2.1, 6.5.2.2, 6.5.2.3, 6.5.2.4, 6.5.2.5, 6.6.2, 6.7.2, 6.8.2 and 6.9.2)

SI No.	Type of Building Occupancy	Type of Installation								Water Supply (in l)			Pump Capacity (in l/min)	
		Fire Extinguisher	Hose Reel	Dry Riser (see Note 6)	Wet Riser	Down-Corner	Yard Hydrant	Automatic Sprinkler System	Manually Operated Electric Fire Alarm Systems	Automatic Detection and Alarm System	Underground Static Water Storage Tank	Terrace Tank	Pump Near Underground Storage Tank (Fire Pump) with Minimum Pressure of 3.5 kg/cm ² at Terrace Level	Pump Near Terrace Tank Level with Minimum Pressure of 2.0 kg/cm ² at Terrace Level
(1)	(2)	(3)	(4)	(5)	(6)	(7)	(8)	(9)	(10)	(11)	(12)	(13)	(14)	(15)
RESIDENTIAL BUILDINGS (A)														
a) Lodging or Rooming Houses (A-1) (see Note 1)														
1) Less than 15 m in height														
i) Up to 15 rooms														
		R	NR	NR	NR	NR	NR	R (see Note 2)	NR	NR	NR	5 000 (see Note 3)	NR	NR
ii) More than 15 and up to 30 rooms														
		R	R	NR	NR	NR	NR	R (see Note 2)	NR	NR	NR	5 000 (5 000) (see Note 4)	NR	450 (450) (see Note 4)
iii) More than 30 rooms														
		R	R	NR	NR	NR	NR	R (see Note 2)	R (see Note 5)	NR	NR	10 000 (5 000) (see Note 4)	NR	450 (450) (see Note 4)
b) One or two Family Private Dwellings (A-2) (see Note 1)														
		NR	NR	NR	NR	NR	NR	NR	NR	NR	NR	NR	NR	NR

Table 23 — Continued

(1)	(2)	(3)	(4)	(5)	(6)	(7)	(8)	(9)	(10)	(11)	(12)	(13)	(14)	(15)
c) Dormitories (A-3)														
Apartment Houses (A-4)														
1)	Less than 15 m in height	R	R	NR	NR	NR	NR	R (see Note 2)	NR	NR	NR	5 000 (5 000) (see Note 4)	NR	450 (450) (see Note 4)
2)	15 m and above but not exceeding 35 m in height	R	R	NR	NR	R	NR	R (see Note 2)	R (see Note 7)	NR	NR	25 000	NR	900
3)	Above 35 m but not exceeding 45 m in height	R	R	NR	R	NR	NR	R (see Notes 2 and 8)	R	NR	75 000	5 000 (5 000) (see Note 4)	(see Note 19)	NR
4)	Above 45 m in height but not exceeding 60 m in height	R	R	NR	R	NR	R	R	R	NR	75 000	10 000	(see Note 20)	NR
5)	Above 60 m in height	R	R	NR	R	NR	R	R	R	R	100 000	25 000	(see Note 21)	NR
d) Hotels (A-5)														
1)	Less than 15 m in height													
i)	Covered area not exceeding 300 m ² on each floor	R	R	NR	NR	NR	NR	R (see Note 2)	R	NR	NR	5 000 (see Note 2)	NR	450 (see Note 3)
ii)	Covered area exceeding 300 m ² but not more than 1 000 m ² on each floor	R	R	NR	R (see Note 5)	NR	NR	R (see Note 2)	R	R	10 000 for every 500 m ² covered area subject to minimum of 50 000 (see Note 5)	10 000 (see Note 2)	(see Notes 5 and 19)	NR
iii)	Covered area exceeding 1 000 m ² on each floor	R	R	NR	R (see Note 9)	NR	R	R (see Note 10)	R	R	100 000 (see Note 9)	10 000 (see Note 2)	(see Notes 9 and 19)	NR

Table 23 — Continued

(1)	(2)	(3)	(4)	(5)	(6)	(7)	(8)	(9)	(10)	(11)	(12)	(13)	(14)	(15)
2)	15 m and above but not exceeding 30 m	R	R	NR	R	NR	R	R	R	R	150 000	20 000	(see Note 20)	NR
3)	Above 30 m in height	R	R	NR	R	NR	R	R	R	R	200 000	20 000	(see Note 21)	NR
e)	Hotels (A-6)	R	R	NR	R	NR	R	R	R	R	200 000	20 000	(see Note 22)	NR
EDUCATIONAL BUILDINGS (B) (see Note 12)														
1)	Less than 15 m in height													
i)	Ground plus one storey	R	NR	NR	NR	NR	NR	R	NR	NR	NR	5 000	NR	450 (see Note 3)
ii)	Ground plus two or more storeys	R	R	NR	NR	NR	NR	R	NR	NR	NR	10 000	NR	450 (450) (see Note 4)
2)	15 m and above but not exceeding 30 m in height	R	R	NR	NR	R	NR	R	R	NR	NR	25 000	NR	900
INSTITUTIONAL BUILDINGS (C) (see Note 12)														
a) Hospitals, Sanatoria and Nursing Homes (C-1)														
1)	Less than 15 m in height with plot area up to 1 000 m ²													
i)	Up to ground plus one storey, with no beds	R	R	NR	NR	NR	NR	R	R	NR	NR	2 500	NR	NR
ii)	Up to ground plus one storey with beds	R	R	NR	NR	R	NR	R	R	NR	NR	5 000	NR	450 (450) (see Note 4)
iii)	Ground plus two or more storeys, with no beds	R	R	NR	NR	R	NR	R	R	R	NR	5 000	NR	450 (450) (see Note 4)
iv)	Ground plus two or more storeys, with beds	R	R	NR	R	NR	NR	R	R	R	50 000	5 000	(see Note 19)	NR

Table 23 — Continued

(1)	(2)	(3)	(4)	(5)	(6)	(7)	(8)	(9)	(10)	(11)	(12)	(13)	(14)	(15)
2)	Less than 15 m in height with plot area more than 1 000 m ²	R	R	NR	R	NR	R	R (see Note 2)	R	R	1 00 000	10 000	(see Note 19)	NR
3)	15 m and above but not exceeding 24 m in height	R	R	NR	R	NR	R	R (see Note 11)	R	R	100 000	20 000	(see Note 20)	NR
4)	Above 24 m and not exceeding 30 m in height	R	R	NR	R	NR	R	R (see Note 11)	R	R	150 000	20 000	(see Note 21)	NR
b)	Custodial (C-2), and Penal and Pental (C-3)													
1)	Less than 10 m in height													
	i) Up to 300 persons	R	R	NR	NR	NR	NR	R (see Note 2)	R	NR	NR	10 000 (5 000) (see Note 4)	NR	450 (900) (see Note 4)
	ii) More than 300 persons	R	R	NR	NR	R	NR	R (see Note 2)	R	NR	NR	15 000 (5 000) (see Note 4)	NR	450 (900) (see Note 4)
2)	10 m and above but not exceeding 15 m in height	R	R	NR	R	NR	R	R (see Note 2)	R	R	50 000	5 000 (5 000) (see Note 4)	(see Note 20)	NR
3)	15 m and above but not exceeding 24 m in height	R	R	NR	R	NR	R	R (see Note 11)	R	R	75 000	10 000	(see Note 20)	NR
4)	24 m and above but not exceeding 30 m in height	R	R	NR	R	NR	R	R (see Note 11)	R	R	100 000	20 000	(see Note 21)	NR
	ASSEMBLY BUILDINGS (D) (see Note 12)													
a)	Buildings (D-1 to D-5)													
1)	Less than 10 m in height													
	i) Up to 300 persons	R	R	NR	NR	R	NR	R (see Note 2)	R	NR	NR	10 000 (5 000) (see Note 4)	NR	450 (450) (see Note 4)

Table 23 — Continued

(1)	(2)	(3)	(4)	(5)	(6)	(7)	(8)	(9)	(10)	(11)	(12)	(13)	(14)	(15)
	ii) More than 300 persons	R	R	NR	NR	R	NR	R (see Note 2)	R	NR	NR	15 000 (5 000) (see Note 4)	NR	900
2)	Above 10 m but not exceeding 15 m in height	R	R	NR	R	NR	NR	R (see Note 2)	R	R	50 000	5 000 (5 000) (see Note 4)	(see Note 20)	450 (450) (see Note 4)
3)	Above 15 m but not exceeding 24 m in height	R	R	NR	R	NR	R	R (see Note 11)	R	R	75 000	10 000	(see Note 20)	NR
4)	Above 24 m but not exceeding 30 m in height	R	R	NR	R	NR	R	R (see Note 10)	R	R	100 000	20 000	(see Note 21)	NR
b)	Multiplex D-6	R	R	NR	R	NR	R	R (see Note 10)	R	R	200 000	20 000	(see Note 22)	NR
c)	D-7	For details see 6.4.8												
BUSINESS BUILDINGS (E)														
1)	Less than 10 m in height	R	R	NR	NR	R	NR	R (see Note 2)	R	NR	NR	10 000 (5 000) (see Note 4)	NR	450 (450) (see Note 4)
2)	Above 10 m but not exceeding 15 m in height	R	R	NR	R	NR	NR	R (see Note 2)	R	R	50 000	5 000 (5 000) (see Note 4)	(see Note 20)	450 (450) (see Note 4)
3)	Above 15 m and up to 24 m in height	R	R	NR	R	NR	R	R (see Note 11)	R	R	75 000	10 000	(see Note 20)	NR
4)	Above 24 m and up to 30 m in height	R	R	NR	R	NR	R	R (see Note 10)	R	R	100 000	20 000	(see Note 21)	NR
5)	Above 30 m in height	R	R	NR	R	NR	R	R (see Note 10)	R	R	200 000	20 000	(see Note 22)	NR
MERCANTILE BUILDINGS (F)														
a)	F-1 & F-2 (see Note 12)													
1)	Less than 15 m in height													
i)	Ground plus one storey, with total covered area not exceeding 500 m ²	R	R	NR	NR	R	NR	R (see Note 2)	NR	NR	NR	5 000 (5 000) (see Note 4)	NR	450 (450) (see Note 4)

Table 23 — Continued

(1)	(2)	(3)	(4)	(5)	(6)	(7)	(8)	(9)	(10)	(11)	(12)	(13)	(14)	(15)
	ii) Ground plus one storey and covered area exceeding 500 m ²	R	R	NR	NR	R	NR	R (see Note 2)	R	NR	NR	25 000	NR	900
	iii) More than ground plus one storey	R	R	R	NR	R	NR	R (see Note 2)	R	NR	NR	5 000 (5 000) (see Note 4)	NR	900
2)	Above 15 m but not exceeding 24 m in height	R	R	NR	R	NR	NR	R (see Note 11)	R	R	100 000	10 000	(see Note 20)	NR
3)	Above 24 m but not exceeding 30 m in height	R	R	NR	R	NR	R	R (see Note 10)	R	R	150 000	10 000	(see Note 21)	NR
b)	Underground shopping complex (F-3) (see Note 13)	R	R	NR	R	NR	R	R (see Note 10)	R	R	150 000	10 000	(see Note 21)	NR
INDUSTRIAL BUILDINGS (G) (see Note 14)														
a)	Low Hazard (G-1) (see Note 15)													
	i) Built up area up to 100 m ²	R	NR	NR	NR	NR	NR	R (see Note 2)	NR	NR	NR	5 000 (see Note 3)	NR	450 (see Note 3)
	ii) Built up area more than 100 m ² and up to 500 m ²	R	R	NR	NR	R	NR	R (see Note 2)	NR	NR	NR	5 000 (5 000) (see Note 4)	NR	450
	iii) Built up area more than 500 m ²	R	R	NR	R	R	R	R	NR	R	100 000	10 000	(see Note 20)	450
b)	Moderate Hazard (G-2) (see Note 14)													
	i) Built up area up to 100 m ²	R	R	NR	NR	NR	NR	R	NR	NR	NR	10 000	NR	450
	ii) Built up area more than 100 m ² and up to 500 m ²	R	R	NR	NR	NR	NR	R	NR	NR	NR	10 000	NR	900

Table 23 — Continued

(1)	(2)	(3)	(4)	(5)	(6)	(7)	(8)	(9)	(10)	(11)	(12)	(13)	(14)	(15)
	iii) Built up area more than 500 m ² and up to 1 000 m ²	R	R	NR	R	R	R	R	R	R	75 000	20 000	(see Note 20)	900
	iv) Built up area more than 1 000 m ²	R	R	NR	R	R	R	R	R	R	100 000	20 000	(see Note 20)	900
	c) High Hazard (G-3) (see Note 16)													
	i) Built up area up to 50 m ²	R	R	NR	NR	NR	NR	R	NR	NR	NR	5 000	NR	450
	ii) Built up area more than 50 m ² and up to 150 m ²	R	R	NR	NR	NR	NR	R	NR	R	NR	5 000	NR	450
	iii) Built up area more than 150 m ² and up to 300 m ²	R	R	NR	R	NR	NR	R	NR	R	25 000	10 000	(see Note 19)	450
	iv) Built up area more than 300 m ² and up to 500 m ²	R	R	NR	R	NR	R	R	R	R	50 000	20 000	(see Note 19)	900
	v) Built up area more than 500 m ²	R	R	NR	R	R	R	R	R	R	100 000	20 000	(see Note 20)	900
	STORAGE BUILDINGS (H) (see Note 17)													
	1) Below 15 m in height and covered area less than 250 m ²	R	R	NR	NR	NR	NR	R	NR	NR	25 000	5 000	(see Note 19)	450
	2) Below 15 m in height and covered area more than 250 m ²													
	i) Ground floor only	R	R	NR	R	NR	R	R	NR	R	50 000	10 000	(see Note 20)	450
	ii) Ground plus one floor	R	R	NR	R	NR	R	R	NR	R	75 000	10 000	(see Note 20)	450

Table 23 — Concluded

(1)	(2)	(3)	(4)	(5)	(6)	(7)	(8)	(9)	(10)	(11)	(12)	(13)	(14)	(15)
iii)	More than ground plus one floor	R	R	NR	R	NR	R	R	NR	R	100 000	10 000	(see Note 20)	450
HAZARDOUS BUILDINGS (J) (see Note 17)														
1)	Up to 15 m in height													
i)	Single Storey Building	R	R	NR	NR	NR	R	R	R	R	Minimum 4 h fire fighting requirements	NR	(see Note 18)	NR
ii)	More than one floor building but not exceeding 15 m	R	R	NR	R	R	R	R	R	R	Minimum 4 h fire fighting requirements	50 000	(see Note 18)	900
R	—	Required												
NR	—	Not Required												

NOTES

- 1 Buildings above 15 m in height not to be permitted for occupancies A-1 and A-2.
- 2 Required to be installed in basement if area of basement exceeds 200 m².
- 3 Required to be provided if basement area exceeds 200 m².
- 4 Additional value given in parenthesis shall be added if basement area exceeds 200 m².
- 5 Required to be provided for buildings with more than two storeys (Ground + One).
- 6 As per the requirement of local authority Dry Riser may be used in hilly areas, industrial areas or as required.
- 7 Required to be provided for buildings with height above 15 m.
- 8 To be installed in basement. If basement provided is used for car parking and area thereof exceeds 750 m² then the sprinklers shall be fed water from both underground static water storage tank and terrace tank.
- 9 Required to be provided for buildings with more than one storey.
- 10 To be installed in entire building.
- 11 To be installed in all floors at appropriate places and in consultation with local fire authorities.
- 12 Buildings above 30 m in height not to be permitted for Group B, Group C, Group D and Group F occupancies.
- 13 All underground shopping areas should be fully air-conditioned.
- 14 The requirements given in this table for Group G Industrial Buildings are for small scale industry units. For other industries the requirements will have to be worked out on the basis of relevant Indian Standards and also in consultation with the local fire authorities.
- 15 Buildings above 18 m in height not to be permitted for G-1 and G-2 occupancies.
- 16 Buildings above 15 m in height not to be permitted for G-3 occupancies.
- 17 Buildings above 15 m in height not to be permitted for Group H and Group J occupancies.

- 18 Pump capacity shall be based on the covered area of the building.
- 19 One electric and one diesel pump of capacity 1 620 l/min and one electric pump of capacity 180 l/min (see Fig. 4).
- 20 One electric and one diesel pump of capacity 2 280 l/min and one electric pump of capacity 180 l/min (see Fig. 4).
- 21 Two electric and one diesel pump of capacity 2 280 l/min and one electric pump of capacity 180 l/min (see Fig. 5).
- 22 Two electric and one diesel pump of capacity 2 850 l/min and one electric pump of capacity 180 l/min (see Fig. 5).
- 23 For buildings 45 m and above, the entire quantity of water for fire fighting purpose (as required in respective occupancy), if provided at the terrace level, the main pump sprinkler pump, jockey pump and common pump need not be provided, however one electric fire pump of 900 LPM capacity with automatic operation is required to be provided.

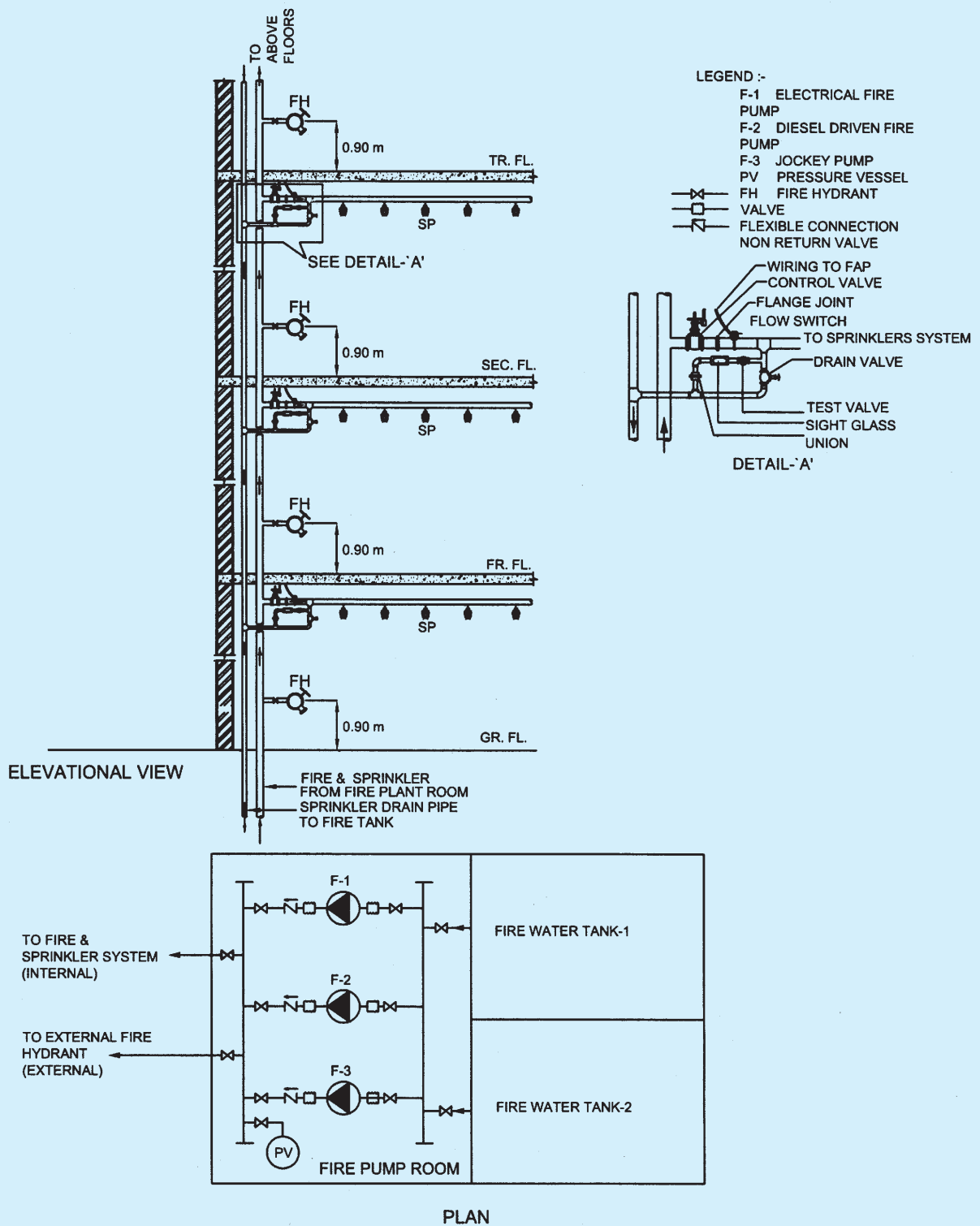

FIG. 4 TYPICAL SYSTEM OF PUMPING WITH ONE ELECTRIC AND ONE DIESEL FIRE PUMP

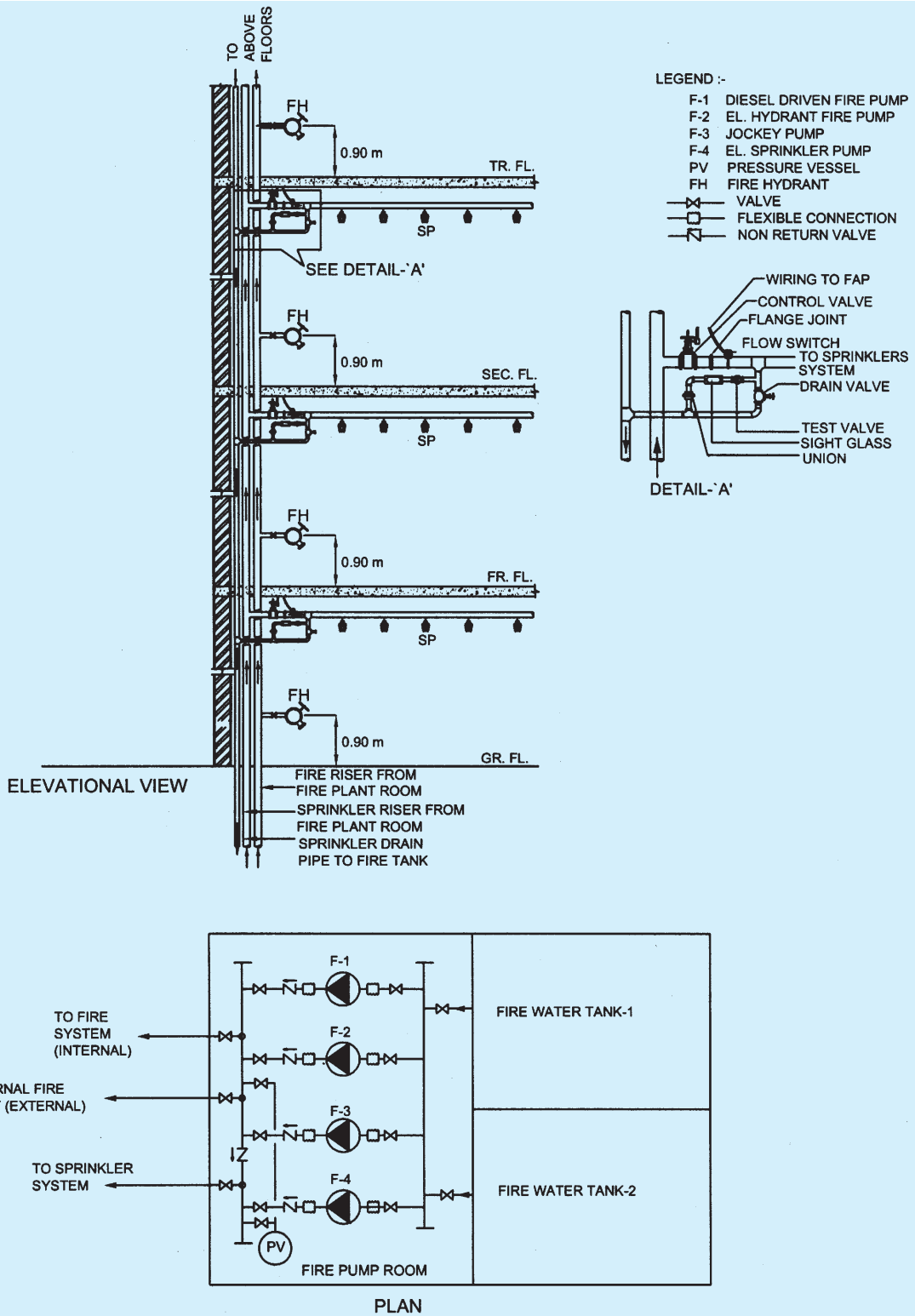

FIG. 5 TYPICAL SYSTEM OF PUMPING WITH TWO ELECTRIC, ONE DIESEL FIRE PUMP

5.1.3 In situations where one occupancy is provided with all the required fire protection arrangements but due to proximity of unprotected buildings around, causing exposure hazard to the protected building, the protected building walls facing the unprotected building shall be made of the requisite fire resistance rated materials or alternatively provided with water curtain/drencher system which can be actuated, when necessary.

5.1.4 First-aid fire fighting appliances shall be provided and installed in accordance with good practice [4(21)]. The fire fighting equipment and accessories to be installed in buildings for use in fire fighting shall be in accordance with the accepted standards contained in [4(20)] and shall be maintained periodically so as to ensure their perfect serviceability at all times.

5.1.5 In addition to wet riser or down-comer, first-aid hose reels shall be installed on all the floors of buildings of 15 m in height or more and shall be in accordance with accepted standards [4(22)]. The first-aid hose reel shall be connected directly to the riser/down-comer main and diameter of the hose reel shall not be less than 19 mm.

5.1.6 *Static Water Storage Tanks*

A satisfactory supply of water for the purpose of fire fighting shall always be available in the form of underground/terrace level static storage tank with capacity specified for each building with arrangements or replenishment by mains of alternative source of supply at the rate of 1 000 l/min for underground static tank. When this is not practicable, the capacity of static storage tank(s) shall be increased proportionately in consultation with the local fire brigade.

The static storage water supply required for the above mentioned purpose shall entirely be accessible to the fire engines of the local fire service. Provision of suitable number of manholes shall be made available for inspection, repairs, insertion of suction hose, etc. The covering slab shall be able to withstand the total vehicular load of 45 T equally divided as a four point load when the slab forms a part of pathway/driveway.

The domestic suction tank connected to the static water storage tank shall have an overflow capable of discharging 2 250 l/min to a visible drain point from which by a separate conduit, the overflow shall be conveyed to a storm water drain.

- a) To prevent stagnation of water in the static water storage tank, the suction tank of the domestic water supply shall be fed only through an overflow arrangement to maintain the level therein at the minimum specified capacity (*see* Fig. 6).

- b) The static water storage tank shall be provided with a fire brigade collecting head with 4 number 63 mm diameter (2 number 63 mm diameter for pump with capacity 1 400 l/min) instantaneous male inlets arranged in a valve box at a suitable point at street level and connected to the static tank by a suitable fixed pipe not less than 150 mm in diameter to discharge water into the tank when required at the rate of 2 250 l/min, if tank is in the basement or not approachable for the fire engines.

5.1.7 *Automatic Sprinklers*

Automatic sprinklers shall be installed in:

- a) basements used as car parks or storage occupancy, if the area exceeds 200 m²;
- b) multi-level basements, covered upper floors used as car parks, and for housing essential services ancillary to a particular occupancy or for storage occupancy, excluding any area to be used for sub-station, A.C. plant and DG set;
- c) any room or other compartment of a building exceeding 1 125 m² in area except as in (g) (*see* Note 1), if so advised by local authority;
- d) departmental stores or shops, if the aggregate covered area exceeds 500 m²;
- e) all non-domestic floors of mixed occupancy which constitute a hazard and are not provided with staircases independent of the remainder of the buildings;
- f) godowns and warehouses, as considered necessary;
- g) on all floors of the buildings other than residential and educational buildings, if the height of the building exceeds 15 m (45 m in case of group housing and apartments) (*see* Note 1);
- h) dressing room, scenery docks, stages and stage basements of theatres;
- j) in hotels, hospitals, industries low and moderate hazard mercantile buildings of height 15 m or above;
- k) in hotels below 15 m, if covered area at each floor is more than 1 000 m²;
- m) false ceiling voids exceeding 800 mm in height (*see* Note 2); and
- n) canteen provided in upper floors of D-1 and D-2 occupancies shall be sprinklered.

NOTES

1 It is desirable that all high rise buildings should be fully sprinklered irrespective of their height and occupancy. If

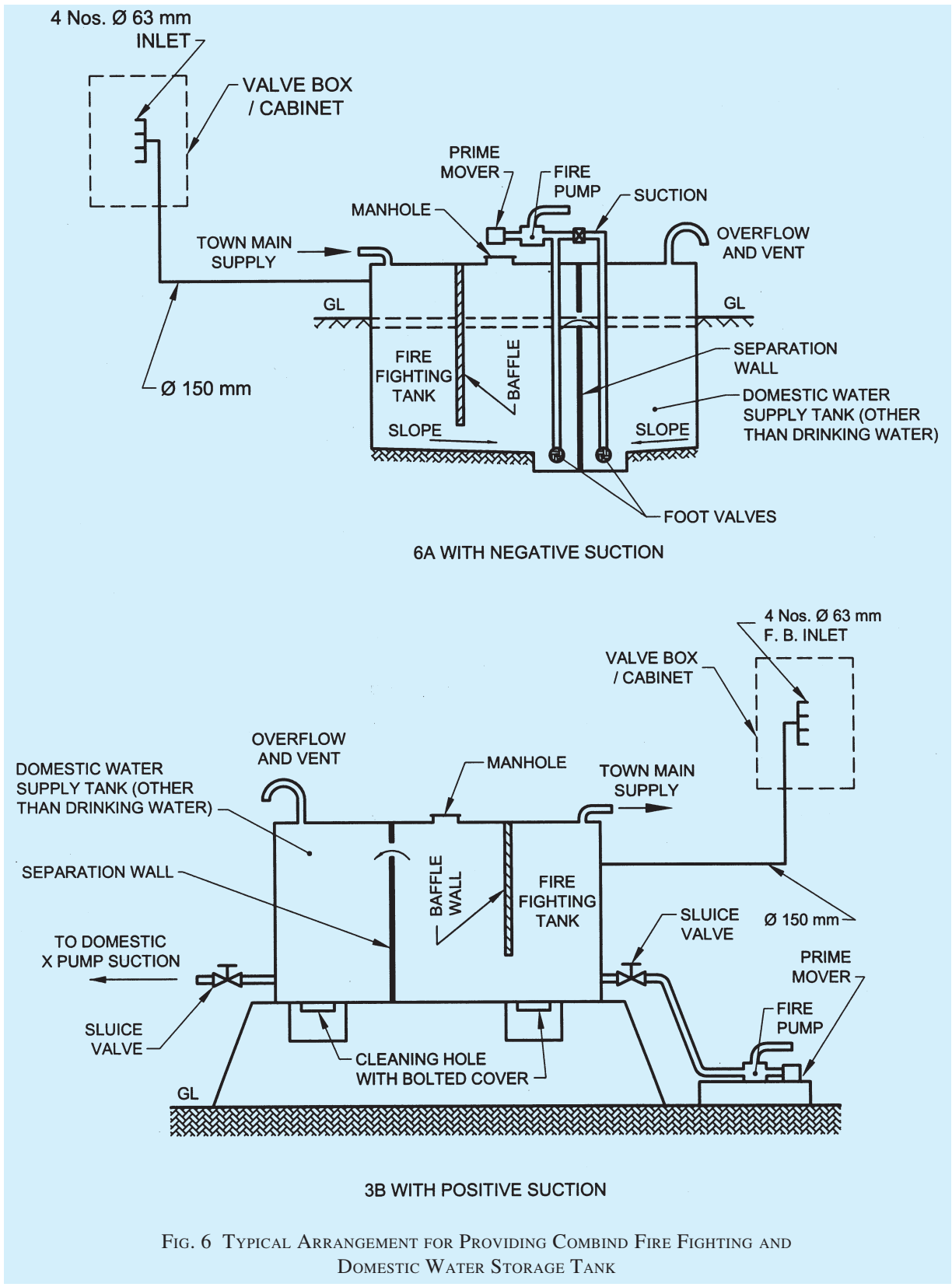

Table 24 Size of Rising Mains/Risers
(Clause 5.1.2)

Size of the Mains (1)	Type of Building (2)	Height of Building (3)	
100 mm as single outlet landing valves	1. Residential buildings (A)		
	i) ¹⁾ Lodging or rooming houses		
	ii) Dormitories		
	iii) One or two family private dwellings	15 m or above and not exceeding 45 m	
	iv) Apartment houses (flats)		
	v) With shopping area not exceeding 500 m ²	Less than 15 m	
	vi) Hotels	15 m or above in height but not exceeding 30 m and area not exceeding 600 m ² per floor	
	-do-	2. Educational buildings (B)	15 m or above but not exceeding 30 m
	-do-	3. Institutional buildings (C)	
		i) For hospitals and sanitorium	15 m or above but not exceeding 30 m
	ii) For custodial institutions and mental institutions	15 m or above but not exceeding 30 m	
-do-	4. Assembly buildings (D)	15 m or above but not exceeding 30 m and total floor area not exceeding 500 m ² /floor (above 30 m, not to be permitted)	
-do-	5. Business buildings (E)	15 m or above but not exceeding 30 m	
-do-	6. Mercantile buildings (F)	15 m or above but not exceeding 30 m (above 30 m, not to be permitted)	
-do-	7. Industrial buildings (G)	15 m or above but not exceeding 18 m	
-do-	8. All buildings classified under 1 (i) to (iv)	Above 45 m	
-do-	9. All buildings classified under 5 above with shopping area exceeding 500 m ²	Above 15 m	
-do-	10. All buildings classified under 1 (v) above	Above 30 m and area exceeding 500 m ²	
150 mm with twin outlet landing valves	11. Hotels	Above 30 m	
-do-	12. All buildings classified under 2 and 3 above	Above 30 m	
-do-	13. All buildings classified under 5 above	Above 30 m	
-do-	14. All storage buildings (H)	Above 10 m but not exceeding 15 m	
-do-	15. All Hazardous buildings (J)	Above 10 m but not exceeding 15 m	

¹⁾ Buildings above 15 m in height not permitted in case of high hazard industrial buildings.

selective sprinklering is adopted, there is a real danger of a fire starting on one of the lower unsprinklered floors gathering momentum, spreading upwards from floor to floor through the unsprinklered floor and reaching the first sprinklered floor as a fully developed fire. In such an event, the sprinklers can be rendered useless or ineffective.

2 Use of false ceiling voids for storage or as return air plenums should be discouraged.

3 For areas having very high ceiling height and other special function areas, where automatic sprinklers cannot be provided, appropriate sprinklers/provisions shall be provided in consultation with local fire authorities.

5.1.8 Automatic High Velocity Water Spray or Emulsifying System

Automatic high velocity water spray or emulsifying system shall be provided for protection of indoor oil-

cooled transformers as applicable in accordance with **C-1.16** and good practice [4(23)].

5.1.9 Fixed Foam Installation

Fixed foam generating system shall be provided for protection of oil storage area for boilers with its ancillary storage of furnace oils in basement. Fixed foam installations can be low, medium or high expansion types, which can cover fire risks in oil storage areas generally. High expansion foams are used for cable tunnels and other confined areas.

5.1.10 Carbon Dioxide Fire Extinguishing System

Fixed carbon dioxide fire extinguishing installation shall be provided in accordance with good practice

[4(24)] on premises where water or foam cannot be used for fire extinguishing because of the special nature of the contents of the buildings/areas to be protected. For some special fire risk/essential applications, carbon dioxide may not be suitable and it may be necessary to provide BCF (Bromochlorodifluoromethane) — Halon 1211 or BTM (Bromochlorotrifluoromethane) — Halon 1301 or some other identified substitutes.

However, the use of halons shall be discouraged, as halons are ozone depleting substances (ODS) and their use is being phased out throughout the world.

5.1.11 Fire fighting equipment shall be suitably located and clearly marked by luminous signs.

NOTE — This provision shall not apply to occupancies A-2 and A-4 less than 15 m in height.

5.2 Fire Detection/Extinguishing System

In buildings of such size, arrangement or occupancy that a fire may not itself provide adequate warning to occupants, automatic fire detection and alarm facilities shall be provided, where necessary, to warn occupants early of the existence of fire, so that they may escape, or to facilitate the orderly conduct of fire exit drills.

5.2.1 The fire detection and extinguishing system shall be in accordance with accepted standards [4(18)]. Guidelines for selection of various types of fire detectors for different occupancies shall be in accordance with good practice [4(19)]. Addressable analog fire detection system shall be preferred.

5.2.2 The requirements of fire detection and alarm systems are also covered for each occupancy in **6.1** to **6.9**; and for high rise buildings (15 m or more in height) in Annex C.

5.3 Fire Extinguisher/Extinguishing System Using Halon Alternatives

Provisions for certain fire extinguishers and extinguishing systems for fire protection which may be used as halon alternatives, shall be in accordance in [4(25)].

6 ADDITIONAL OCCUPANCY-WISE REQUIREMENTS

6.1 Requirements of Residential Buildings (Group A)

6.1.1 In addition to the general requirements for the type of construction and occupancy group specified in **3.4** and the exit requirements given in **4**, the requirements **6.1.2** to **6.1.4.10** shall be complied with. The capacity of any open mezzanine or balcony shall be added to the capacity of the floor below for the purpose of determining exit capacity.

6.1.2 Fire Detection/Extinguishing System

The requirements for occupancy sub-divisions A-1 to

A-5 as specified in Table 23 and Annex C (for High Rise Buildings) shall apply.

6.1.3 Exit Facilities

The capacity of any open mezzanine or balcony shall be added to the capacity of the floor for the purpose of determining the exit capacity.

6.1.3.1 In addition to requirements specified for occupancy sub-division A-2, the following shall be provided for occupancy sub-division A-1:

Every sleeping room above the street floor shall have access to two separate means of exits, at least one of which shall consist of an enclosed interior stairway, or a fire escape or horizontal exit all so arranged as to provide a safe path of travel to the outside of the building without traversing any corridor or space exposed to an unprotected vertical opening.

6.1.3.2 For occupancy sub-division A-2 of more than two rooms, every occupied room, excluding areas used solely for storage shall have at least two means of exits, at least one of which shall be a door or a stairway providing a means of un-obstructed travel to the outside of the building or street or grade level. No room or space shall be occupied which is accessible only by a ladder, folding stairs or through a trap door.

Further the following provisions shall be made:

All locking devices, which would impede or prohibit exit, such as chain type bolts, limited opening sliding type locks and burglar locks, which are not dis-engaged easily by quick-releasing catches, shall be prohibited. All closet door latches shall be such that even children can open the doors from inside. All bathroom door locks or fasteners shall be designed to permit the opening of the locked or closed door from the outside in an emergency without the use of a special key.

6.1.3.3 For occupancy sub-division A-3, the following provisions shall apply:

All dormitories shall have exits so arranged that from any sleeping room or open dormitory sleeping area, there shall be access to two separate and distinct exits in different directions with no common path of travel unless the room or space is subject to occupancy by not more than 10 persons and has a door opening directly to the outside of the building at street or grade level, or to an outside stairway in which case one means of exit may be accepted.

6.1.3.4 For occupancy sub-division A-4, the following provisions shall apply:

- a) Every individual living unit covered by occupancy sub-division A-4 shall comply with the requirement for occupancy sub-division A-2 in respect of exits.
- b) Every living unit shall have access to at least two separate exits, which are remote from each other and are reached by travel in different directions, except that a common path of travel may be permitted for the first 6 m (that is a dead end corridor up to 6 m long may be permitted) provided that single exit may be permitted under any of the conditions given under (c).
- c) Any part of building lower than the grade level shall have direct accessibility from outside.
- d) At least half of required exits shall discharge direct to the outside of the buildings; any other exit shall be the same as required for hotels.

6.1.3.5 For occupancy sub-divisions A-5 and A-6, the following provisions shall apply:

- a) Not less than two exits, as remote from each other as practicable, shall be accessible from every floor, including basements occupied for hotel purpose, except as a single exit as permitted in (b) below. Exits and ways of access thereto shall be so arranged that they are accessible in at least two different directions from every point in any open area, or from any room door.
- b) Any room or section with an outside door at street or grade level may have such outside door as a single exit, provided no part of the room or area is more than 15 m from the door measured along the natural path of travel.
- c) Provision of panic bars shall be provided in the exits.

6.1.3.5.1 Where stairways or other exits serve two or more upper floors, the same stairway or other exit required to serve any one upper floor may also serve other upper floors, except that no inside open stairway or ramp may serve as a required egress facility from more than one floor [*see* good practice 4(26)].

6.1.3.6 *Basement Exits*

- a) Basements occupied for hotel purposes shall have exits arranged in accordance with **6.1.3.5**.
- b) Basement exits shall be sufficient to provide for the capacity of the basement as determined in accordance with **6.1.1**. In no case shall there be less than two independent basement exits.
- c) Basement or sub-basements not open to the public and used only for heating equipment,

storage and service operations (other than kitchens, which are considered part of the hotel occupancy) shall have exits appropriate to the actual occupancy, in accordance with other applicable provisions of the Code, or in case of mixed occupancy where there may be doubt as to which other section is applicable, such basements shall have exits determined on the basis of lesser exit capacity.

6.1.4 **Additional Precautions**

6.1.4.1 Flammable liquids for household purposes shall be kept in tightly stoppered or sealed containers. For the limits of quantities of flammable liquids to be allowed in various occupancies, reference may be made to appropriate regulations.

6.1.4.2 No stove or combustion heater shall be located directly under or immediately at the foot of stairs or otherwise so located as to block escape in case of malfunctioning of the stove or heater.

6.1.4.3 All kitchen exhaust fans, where provided, shall be fixed to an outside wall or to a duct of non-combustible material, which leads directly to the outside. The ducts must not pass through areas having combustible materials.

6.1.4.4 All wiring shall be done in accordance with Part 8 'Building Services, Section 2 Electrical Installations', good practice [4(10)] and National Electric Code.

6.1.4.5 Where television is installed, all outdoor antennae shall be properly grounded and protected from lightning (*see* Part 8 'Building Services, Section 2 Electrical Installations').

6.1.4.6 Doors leading to rooms in which flammable liquids are stored or used shall be as in **4.7**. Such assembly shall be self-closing and shall be posted with a sign on each side of the door in 25 mm high block letters stating — 'FIREDOOR — KEEP CLOSED'.

6.1.4.7 Where a boiler room is provided or a central heating plant is installed, which uses solid or liquid fuel, it shall be separated from rest of the building by a separation wall with all openings protected as in **3.4.7** and **3.4.8**.

6.1.4.8 Rooms containing high pressure boilers, refrigerating machinery, transformers or other service equipment subject to possible explosion shall not be located directly under or adjacent to exits. All such rooms shall be effectively cut off from other parts of the building and shall be provided with adequate vents to the outside air.

6.1.4.9 All rooms or areas of high hazard in additions to those herein before mentioned, shall be segregated

or shall be protected as may be directed by the enforcing Authority where, in the opinion of the enforcing Authority, fire, explosion or smoke there from is likely to interfere with safe egress from the building.

6.1.4.10 For detailed information regarding fire safety requirements for hazardous petroleum products, reference may be made to the *Petroleum Act, 1934* and the Rules thereof.

6.2 Requirements of Educational Buildings (Group B)

6.2.1 In addition to the general requirements specified in **3.4** for the type of construction and occupancy group and the exit requirements given in **4**, the requirements given in **6.2.2** to **6.2.6.3** shall be complied with.

6.2.2 Buildings intended for educational occupancy shall not be used for any hazardous occupancy.

6.2.3 Fire Detection/Extinguishing System

The requirements for occupancy sub-divisions B-1 and B-2 as specified in Table 23 and Annex C (for High Rise Buildings) shall apply.

6.2.4 Exit Facilities

The capacity of any open mezzanine or balcony shall be added to the capacity of the floor for the purpose of determining the exit capacity.

In addition to the provisions in **4**, the following shall be provided:

6.2.4.1 Exits, in accordance with **4** shall be so arranged that at least two separate exits are available in every floor area. Exits shall be as remote from each other as practicable and so arranged that there are no pockets or dead ends of appreciable size in which occupants may be trapped.

6.2.4.2 Every room with a capacity of over 45 persons in area shall have at least two doorways.

6.2.4.3 Exterior doors shall be operated by panic bars or some other panic hardware device, except that doors leading from classrooms directly to the outside may be equipped with the same type of lock as is used on classroom doors leading to corridor, with no provision whatsoever for locking against egress from the classroom.

6.2.5 Additional Precautions

6.2.5.1 Storage of volatile flammable liquids shall be prohibited and the handling of such liquids shall be restricted to science laboratories only.

6.2.5.2 Each building shall be provided with an approved outside gas shut-off valve conspicuously

marked. The detailed requirements regarding safe use of gas shall be as specified in Part 9 'Plumbing Services, Section 3 Gas Supply'.

6.2.5.3 All exterior openings in a boiler room or rooms containing central heating equipment, if located below opening in another storey or if less than 3 m from other doors or windows of the same building, shall be protected by a fire assembly as in **3.4.8**. Such assemblies shall be fixed, automatic or self-closing. Provisions of **6.1.4.7** shall also apply to this group of occupancy.

6.2.6 Exception and Deviation

6.2.6.1 Gymnasiums, indoor stadiums and similar occupancies may have floors/running tracks of wood, cinder, synthetic or unprotected steel or iron.

6.2.6.2 In gymnasiums and in multi-purpose school rooms having an area not greater than 300 m², 25 mm nominal tight tongue-and-grooved or 20 mm plywood wall covering may be used in the inner side in lieu of fire-resistant plaster.

6.2.6.3 A building, which will have only the first floor and is accessible to not more than 20 pupils at any time, may be used for school purposes with the following exceptions:

- a) Exterior walls or parts of walls which are less than 900 mm from adjacent property lines shall have no openings therein.
- b) Classrooms may have only one exit not less than 900 mm wide.

6.3 Requirements of Institutional Buildings (Group C)

6.3.1 In addition to the general requirements specified in **3.4** for the type of construction and occupancy group and the exit requirements given in **4**, the requirements given in **6.3.2** to **6.3.5** shall be complied with.

6.3.2 Fire Detection/Extinguishing System

The requirements for occupancy sub-divisions as specified in Table 23 and Annex C (for High Rise Buildings) shall apply.

6.3.3 Exit Facilities

In addition to the provisions of **4**, the following requirements shall be complied with.

6.3.3.1 In buildings or sections occupied by bed-ridden patients where the floor area is over 280 m², facilities shall be provided to move patients in hospital beds to the other side of a smoke barrier from any part of such building or section not directly served by approved horizontal exits or exits from the first floor (floor 2) of a building to the outside.

6.3.3.2 Not less than two exits of one or more of the following types shall be provided for every floor, including basement, of every building or section:

- a) Doors leading directly outside the building;
- b) Stairways;
- c) Ramps;
- d) Horizontal exits; and
- e) Fire tower.

6.3.3.3 All required exits that serve as egress from hospital or infirmary sections shall be not less than 2 m in clear width including patient bedroom doors to permit transportation of patients on beds, litters, or mattresses. The minimum width of corridors serving patients bedrooms in buildings shall be 2 400 mm. For detailed information on recommendations for buildings and facilities for the physically handicapped, reference may be made to good practice [4(27)].

6.3.3.4 Elevators constitute a desirable supplementary facility, but are not counted as required exits. Patient lifts shall also be provided with enough room for transporting a stretcher trolley.

6.3.3.5 Any area exceeding 500 m² shall be divided into compartments by fire resistant walls.

6.3.3.6 Doors in fire resistant walls shall be so installed that these may normally be kept in open position, but will close automatically. Corridor door openings in smoke barriers shall be not less than 2 000 mm in width. Provision shall also be made for double swing single/double leaf type door.

6.3.3.7 Exits and other features for penal and mental institutions, and custodial institutions shall be the same as specified for hospitals, in so far as applicable. Reliable means shall be provided to permit the prompt release of inmates from any locked section in case of fire or other emergency.

6.3.3.8 Wherever any inmates are confined in any locked rooms or spaces, adequate guards or other personnel shall be continuously on duty or immediately available to provide for release of inmates or for such other action as may be indicated in case of fire or other emergency.

6.3.3.9 No building constructed in whole or in part of combustible materials shall be used to confine inmates in cells or sleeping quarters, unless automatic sprinkler protection is provided.

6.3.3.10 All buildings or sections of buildings in penal and mental institutions used for manufacturing, storage or office purposes shall have exits in accordance with the provisions of the Code for those occupancies.

6.3.4 Additional Precautions

6.3.4.1 No combustible material of any kind shall be

stored or used in any building or section thereof used for institutional occupancy, except as necessary to normal occupancy and use of the building.

6.3.4.2 Bare minimum quantities of flammable material such as chloroform, ethyl alcohol, spirit, etc shall be allowed to be stored and handled. The handling of such liquids shall not be permitted by un-authorized persons. Bulk storage of these items, will be governed by relevant rules and safe practices.

6.3.5 Exceptions and Deviations

It is recognized that in institutions or part of buildings housing various types of psychiatric patients, or used as penal and mental institutions, it is necessary to maintain locked doors and barred windows; and to such extent the necessary provision in other sections of the Code requiring the keeping of exits unlocked may be waived. It is also recognized that certain type of psychiatric patients are not capable of seeking safety without adequate guidance. In buildings where this situation prevails, reliable means for the rapid release of occupants shall be provided, such as remote control of locks, or by keying all locks to keys commonly used by attendants.

6.4 Requirements of Assembly Buildings (Group D)

6.4.1 In addition to the general requirements specified in 3.4 for type of construction and occupancy group and the exit requirements given in 4, the requirements given in 6.4.2 to 6.4.8.9 shall be complied with.

6.4.2 Mixed Occupancy

Places of assembly in buildings of other occupancy, such as ballrooms in hotels, restaurants in stores and assembly rooms in schools, shall be so located, separated or protected as to avoid any undue danger to the occupants of the place of assembly from a fire originating in the other occupancy or smoke therefrom.

6.4.3 Fire Detection/Extinguishing System

The requirements for occupancy sub-divisions D-1 to D-5 as specified in Table 23 and Annex C (for High Rise Buildings) shall apply.

NOTE — Canteens shall not be provided in basements. If provided in the upper floors, it shall be sprinklered.

6.4.4 Exit Facilities

6.4.4.1 Every place of assembly, every tier or balcony, and every individual room used as a place of assembly shall have exits sufficient to provide for the total capacity thereof as determined in accordance with 4. Door width for assembly buildings shall not be less than 2 000 mm.

- a) Every place of assembly of sub-division D-1

shall have at least four separate exits as remote from each other as practicable.

- b) Every place of assembly of sub-division D-2, shall have at least two separate exits as remote from each other as practicable and if of capacity over 600 at least three exits shall be provided with each exit not less than of 2 000 mm width.

6.4.4.2 Clear aisles not less than 1.2 m in width shall be formed at right angles to the line of seating in such number and manner that no seat shall be more than seven seats away from an aisle. Rows of seats opening on to an aisle at one end only shall have not more than seven seats. Under the conditions, where all these aisles do not directly meet the exit doors, cross-aisles shall be provided parallel to the line of seating so as to provide direct access to the exit, provided that not less than one cross aisle for every 10 rows shall be required. The width of cross-aisles shall be minimum of 1 m. Steps shall not be placed in aisles to overcome differences in levels, unless the gradient exceeds 1 in 10.

6.4.4.3 The fascia of boxes, balconies and galleries shall have substantial railings not less than 1 000 mm high above the floor. The railings at the end of aisles extending to the fascia shall be not less than 1 100 mm high for the width of the aisle or 1 200 mm high at the foot of steps.

6.4.4.4 Cross-aisles except where the backs of seats on the front of the aisle project 600 mm or more above the floor of the aisle shall be provided with railings not less than 900 mm high.

6.4.4.5 No turnstiles or other devices to restrict the movement of persons shall be installed in any place of assembly in such a manner as to interfere in any way with the required exit facilities.

6.4.4.6 In theatres and similar places of public assembly where persons are admitted to the building at a time when seats are not available for them and are allowed to wait in a lobby or similar space until seats are available, such use of lobby or similar space shall not encroach upon the required clear width of exits. Such waiting shall be restricted to areas separated from the required exit ways by substantial permanent partitions or fixed rigid railing not less than 105 cm high. Exits shall be provided for such waiting spaces on the basis of one person for each 0.3 m² of waiting space area. Such exits shall be in addition to the exits specified for the main auditorium area and shall conform in construction and arrangement to the general rules of exits given above.

6.4.4.7 No display or exhibit shall be so installed or operated as to interfere in any way with access to any required exit, or with any required exit sign.

All displays or exhibits of combustible material or construction and all booths and temporary construction in connection therewith shall be so limited in combustibility or protected as to avoid any undue hazard of fire which might endanger occupants before they have opportunity to use the available exits, as determined by the authority.

6.4.4.8 Places of assembly in buildings of other occupancy may use exits common to the place of assembly and the other occupancy, provided the assembly area and the other occupancy are considered separately, and each has exits sufficient to meet the requirements of the Code.

6.4.4.9 Exits shall be sufficient for simultaneous occupancy of both the places of assembly and other parts of the building, unless the Authority determines that the conditions are such that simultaneous occupancy will not occur.

6.4.4.10 For any place of assembly under sub-division D-1, at least half the required means of exits shall lead directly outdoors or through exit ways completely separated from exits serving other parts of the building.

6.4.4.11 For detailed information regarding cinema buildings, reference may be made to good practice [4(28)].

6.4.5 *Lighting*

No open flame lighting devices shall be used in any place of assembly, except in the following cases:

- a) Where necessary for ceremonial purposes, the enforcing Authority may permit open flame lighting under such restrictions as are necessary to avoid danger of ignition of combustible materials or injury to occupants.
- b) Candles may be used on restaurant tables if securely supported on non-combustible bases and so located as to avoid danger of ignition of combustible materials.
- c) Open flame devices may be used on stages where they are a necessary part of theatrical performance, provided adequate precautions, satisfactory to the Authority are taken to prevent ignition of combustible materials.

6.4.6 *Additional Precautions*

6.4.6.1 The decorations of places of assembly shall be of non-flammable materials. Fabrics and papers used for such purpose shall be treated with an effective flame-retardant material. Stage settings made of combustible materials shall likewise be treated with fire retardant materials of Class 1 flame spread.

6.4.6.2 Seats in places of public assembly, accommodating more than 300 persons, shall be

securely fastened to the floor, except as permitted in 6.4.6.3. All seats in balconies and galleries shall be securely fastened to the floor, except that in nailed-in enclosures, boxes with level floors and having not more than 14 seats, the seats need not be fastened.

6.4.6.3 Chairs not secured to the floor may be permitted in restaurants, night clubs and other occupancies where the fastening of seats to the floor may not be practicable, provided that in the area used for seating, excluding dance floor, stage, etc, there shall be not more than one seat for each 1.4 m² of floor area and adequate aisles to reach exits shall be maintained at all times.

6.4.6.3.1 Rows of seats between aisles shall have not more than 14 seats.

6.4.6.3.2 Rows of seats opening on to an aisle at one end only shall have not more than 7 seats.

6.4.6.3.3 Seats without dividing arms shall have their capacity determined by allowing 450 mm per person.

6.4.6.4 The spacing of rows of seats from back-to-back shall be neither less than 850 mm nor less than 700 mm plus the sum of the thickness of the back and inclination of the back. There shall be a space of not less than 350 mm between the back of one seat and the front of the seat immediately behind it as measured between plumb lines.

6.4.6.5 Rooms containing high pressure boilers, refrigerating machinery other than domestic refrigerator type, large transformers or other service equipments subject to possible explosion shall not be located directly under or adjacent to the required exits. All such rooms shall be effectively cut off from other parts of the building and provided with adequate vents to the outer air.

6.4.6.6 All rooms or areas used for storage of any combustible materials or equipment, or for painting, refinishing, repair or similar purposes shall be effectively cut off from assembly areas or protected with a standard system of automatic sprinklers. They shall be located away from staircases.

6.4.6.7 Every stage equipped with fly galleries, grid irons and rigging for movable theatre type scenery, shall have a system of automatic sprinklers over and under such stage areas or spaces and auxiliary spaces, such as dressing rooms, store rooms and workshops, and the proscenium opening shall be provided with a fire-resisting curtain, capable of withstanding a lateral pressure of 4 kN/m² over the entire area. The curtain shall have an emergency closing device capable of causing the curtain to close without the use of power and when so closed, it shall be reasonably tight against the passage of smoke.

6.4.6.8 The stage roof of every theatre using movable scenery or having a motion picture screen of highly combustible construction shall have a ventilator or ventilators in or above it, openable from the stage floor by hand and also opening by fusible links or some other approved automatic heat/smoke actuated device, to give a free opening equal to at least one-eighth the area of the floor of the stage.

6.4.6.9 The proscenium wall of every theatre using movable scenery of decorations shall have, exclusive of the proscenium opening, not more than two openings entering the stage, each not to exceed 2 m² and fitted with self-closing fire resistant doors.

6.4.6.10 Every place of assembly in which projection of motion pictures by light is made shall have the projection apparatus enclosed in a fire-resisting fixed booth in accordance with good practice [4(27)], except that such booth shall not be required where no nitrocellulose motion picture film is used.

6.4.6.11 Automatic smoke vents actuated by smoke detectors shall be installed above the auditorium or theatres, including motion picture houses, with vent area equal to not less than 3 percent of the floor area of the auditorium, including the sum of the floor areas of all balconies, galleries, boxes and tiers. It may be desirable to provide a large number of small vents rather than a small number of large vents.

6.4.7 *Exception and Deviation*

6.4.7.1 Where boilers or central heating plants using liquid or solid fuel are located at grade level, these shall be separated from the remainder of the building by a separating wall with openings protected as in 3.4.7 and 3.4.8.

6.4.7.2 Gymnasiums, indoor stadiums and similar occupancies may have floors/running tracks of wood, cinder, synthetic or un-protected steel or iron.

6.4.7.3 The underside of continuous steel deck grand stands when erected outdoors need not be fire-protected when occupied for public toilets.

6.4.8 *Fire Protection and Fire Fighting System for Metro Stations*

6.4.8.1 *Wet riser system*

Main and diesel fire pump of 1 800 l/min capacity to be provided to support 3 to 4 hydrants at a time. Jockey pump capacity shall be 180 l/min. Where it is possible to extend reliable DG supply to the fire pump room without routing through the station building, the provision of diesel pump can be dispensed with and instead, two electric pumps may be provided out of which at least one should have DG back-up. The jockey pump should also have DG back-up.

6.4.8.2 Internal hydrant

The internal hydrant is proposed to be provided with 2 number RRL hose pipes of 38 mm dia with 63 mm standard instantaneous coupling along with associated branch pipes and cabinet and a first aid hose reel of 25 mm dia, length 45 m and fitted with 6.5 mm nozzle.

Two internal hydrants are proposed to be provided on each platform in such a way so that most of the platform is covered by hose. However, in case of necessity, the hose pipes from other hose cabinets can be utilized for extending the length of fire hose pipe for fire fighting, if need be. At the concourse level minimum two hydrants will be provided. In station where the concourse is split into two halves at least one hydrant is to be provided in each half of the concourse. Further, in case the area is more than 2 000 m², an additional first aid hose-reel point shall be provided for every additional 1 000 m².

In addition, hydrants shall be provided in commercial areas also.

One hydrant shall be provided at entry of each station at ground floor for providing the coverage to the parking area.

6.4.8.3 Sprinklers

Sprinklers are required to be provided only in the commercial areas, if any, in the station. The commercial areas will be segregated from the station area through 2 h fire rated walls and doors. Additional sprinkler pumps are not required, as two pumps already provided for hydrant system will take care of the sprinkler flow requirements.

However, if such commercial areas in the premises of stations are in isolated building separate from the station building then the provision of sprinkler pump and water tank capacities shall be as per this Code. The water storage and pumps may however be common.

6.4.8.4 Detectors

Detectors are required to be provided only in areas where there are false ceiling and false floor and areas of equipment rooms. Wherever there are false ceiling, the detectors should be provided both above and below

false ceiling giving due consideration to depth of false ceiling/flooring. However, in concourse, the detectors below false ceiling may not be effective due to heights/cross ventilation and therefore may not be provided. In other areas, because of high heights and cross-ventilations, detectors will not be effective and hence therefore can be dispensed. A conventional detection system will suffice at a normal station.

6.4.8.5 Manual call box

Manual call box should be provided at a central place on each platform (near emergency plunger) and at least two on the concourse, on each sidewall. When the concourse in two halves there should be one manual call box on each side.

6.4.8.6 Manual panel gas flooding

Electric panels should have provision of manual gas flooding. Alternatively panels can be provided with linear heat sensing tubes with CO₂ cylinder. This required to be provided only in main power panels, that is HT panel, main LT panel, main LT distribution board and essential power panels and other such major panels.

6.4.8.7 External area of the station

A 'two way/four way' fire brigade inlet to be provided at ground level on each rising main for hydrants/sprinkles.

The 'Draw Off Connection' shall be provided on the underground tank for fire brigade.

6.4.8.8 Water tank capacity

Capacity of fire tanks at stations without any commercial development (Beverage stall/ATM/Florist/Book stalls up to total 250 m² excluded) shall be 50 000 litres.

However, at stations having commercial development, the fire tank capacity shall be 100 000 litres.

6.4.8.9 Portable fire extinguishers

For the purpose of standardization, the following portable extinguishers are recommended:

- | | |
|---------------------------------------|----------|
| a) Water CO ₂ type | 9 litres |
| b) CO ₂ fire extinguishers | 4.5 kg |

They shall be provided in various areas as detailed hereunder:

<i>Sl No.</i>	<i>Item</i>	<i>Numbers and Location</i>
(1)	(2)	(3)
PLATFORM		
1.	Internal Hydrants	Two at each platform. The hydrants at two platforms may be staggered for maximum coverage.
2.	Manual call box	One on each platform preferably near emergency plunger.
3.	Portable Extinguishers	One set of Water CO ₂ and CO ₂ type on each platform at a central area.
CONCOURSE		
1.	Internal Hydrants	Two at each concourse. When concourse is in two parts then each part should have at least one hydrant.
2.	Additional first-aid reel point	Additional first-aid reel point for every additional 1 000 m ² , if the area is more than 2 000 m ² . Similarly, if the concourse is in two parts then additional first aid reel point for every additional 1 000 m ² , if the area of the part is more than 1 000 m ² .
3.	Manual call box	Two at each concourse. When concourse is in two parts then each part should have at least one.
4.	Portable Extinguishers	Two sets at each concourse. When concourse is in two parts then each part should have at least one set.
5.	Detectors	Above false ceiling where depth of false ceiling is greater than 800 mm. Required in commercial areas also.
EQUIPMENT ROOM AREAS		
1.	Internal Hydrants/first-aid reel point	The requirement shall get covered with platform/concourse. Additional first-aid reel point may be provided, if required.
2.	Manual call box	One at a central place. When the equipment rooms are in two/more parts then each part should have one.
3.	Portable Extinguishers	One set for each room.
4.	Detectors	Above and below false ceiling and below floor giving due consideration to depth of false ceiling/floor.
5.	Response Indicator	To be provided.
6.	Panel gas flooding	To be provided for HT panel, main LT panel, main LT distribution board and essential power panels and other such major panels.
EXTERNAL AREAS		
1.	Hydrants	One at ground floor at each entry to station near staircase/DG room.
2.	Two/four way fire brigade inlet	To be provided for each riser/sprinkler riser.
3.	Fire brigade Draw-off connection	To be provided on water tank.

6.5 Business Buildings (Group E)

6.5.1 In addition to the general requirements specified in 3.4 for type of construction and occupancy group and the exit requirements given in 4, the requirements given in 6.5.2 to 6.5.5 shall be complied with.

6.5.2 Fire Detection/Extinguishing System

The requirements for occupancy sub-divisions as specified in Table 23 and Annex C (for High Rise Buildings) shall apply.

6.5.2.1 Occupancy sub-division E-1 (except office buildings)

<i>Details of Occupancy</i>	<i>Fire Detection/Extinguishing System</i>
E-1	Automatic fire alarm system {good practice [4(17)] and [4(18)], and Table 23}.

6.5.2.2 Occupancy sub-division E-2

<i>Details of Occupancy</i>	<i>Fire Detection/Extinguishing System</i>
a) Laboratory with delicate instruments	Fixed automatic CO ₂ fire extinguishing system or automatic fire alarm system {good practice [4(18)] and [4(19)], and Table 23}
b) Solvent storage and/or flammable liquid	Automatic foam installation or automatic CO ₂ fire extinguishing system

6.5.2.3 Occupancy sub-division E-3

<i>Details of Occupancy</i>	<i>Fire Detection/Extinguishing System</i>
a) Area of computer installations	Automatic fire alarm system {good practice [4(18)] and [4(19)], and Table 23} any suitable halon alternative fire extinguishing system (<i>see 5.3</i>) or any other suitable fire extinguishing installation { <i>see also</i> [4(29)]}.
b) Space under false ceiling (floor)	Automatic fire alarm system {good practice [4(18)] and [4(19)], and Table 23}
c) Space above false ceiling and below false floor	Automatic fire alarm system {good practice [4(18)] and [4(19)], and Table 23}
d) Electrical switch board	Automatic fire alarm system {good practice [4(18)] and [4(19)], and Table 23} and CO ₂ fire extinguishing installation

6.5.2.4 Occupancy sub-division E-4

<i>Details of Occupancy</i>	<i>Fire Detection/Extinguishing System</i>
Telephone exchanges	Any suitable halon alternative fire extinguishing system (<i>see 5.3</i>) and/or automatic sprinkler system as per requirement (<i>see also</i> Table 23)

6.5.2.5 Occupancy sub-division E-5

<i>Details of Occupancy</i>	<i>Fire Detection/Extinguishing System</i>
Broadcasting stations	Automatic fire alarm system based on smoke detectors and sprinkler system (<i>see also</i> Table 23)

6.5.3 Exit Facilities

6.5.3.1 In the case of mezzanines or balconies open to the floor below, or other unprotected vertical openings between floors, the population of the mezzanine or other subsidiary floor for level shall be added to that of the main floor for the purpose of determining the required exits, provided, however, that in no case shall the total number of exit units be less than that required if all vertical openings were enclosed.

6.5.3.2 Not less than two exits shall be provided for every floor, including basements occupied for office purposes or uses incidental thereto.

6.5.4 Additional Requirements

6.5.4.1 The handling and use of gasoline, fuel oil and other flammable liquids shall not be permitted, unless such use and handling complies with the appropriate regulations.

6.5.4.2 Every boiler room or room containing a central heating plant using solid or liquid fuel shall be separated from the rest of the building by a separating wall. Every boiler room or room containing a central heating plant, which burns gas as a fuel shall be adequately separated from the rest of the building.

6.5.5 Exception and Deviation

6.5.5.1 Basements used only for storage, heating, any other service equipment shall conform to exit requirements for Group H occupancies in all respects.

6.6 Requirements of Mercantile Buildings (Group F)

6.6.1 In addition to the general requirements specified in 3.4 for type of construction and occupancy and the exit requirements given in 4, the requirements given in 6.6.1.1 to 6.6.5 shall be complied with.

6.6.1.1 Mixed occupancy

No dwelling unit shall have its sole means of exit through any mercantile occupancy in the same building except in the case of a single family unit where the family operates the store.

6.6.2 Fire Detection/Extinguishing System

The requirements for occupancy sub-divisions F-1 to F-3 as specified in Table 23 and Annex C (for High Rise Buildings) shall apply.

6.6.3 Exit Facilities

In addition to the provisions of 4, the following requirements shall be complied with.

6.6.3.1 In the case of mezzanines or balconies open to the floor below, or other un-protected vertical openings between floors, the population or area of the

mezzanine or other subsidiary floor level shall be added to that of the main floor for the purpose of determining the required exits, provided, however, that in no case shall the total number of exit units be less than that required if all vertical openings were enclosed.

6.6.3.2 At least two separate exits shall be accessible from every part of every floor, including basements; such exits shall be as remote from each other as practicable and so arranged as to be reached by different paths of travel in different directions, except that a common path of travel may be permitted for the first 15 m from any point.

6.6.4 Additional Precautions

6.6.4.1 Requirements specified in **6.5.4.1** shall be applicable to all Group F occupancies also.

6.6.4.2 Hazardous areas of mercantile occupancies shall be segregated or protected suitably.

6.6.4.3 In self-service stores, no check-out stand or associated railings or barriers shall obstruct exits or required aisles or approaches thereto.

6.6.4.4 Open-air mercantile operations, such as open-air markets, gasoline filling stations, roadside stands for the sale of a farm produce and other outdoor mercantile operations shall be so arranged and conducted as to maintain free and unobstructed ways of travel at all times to permit prompt escape from any point of danger in case of fire or other emergency, but no dead-ends in which persons might be trapped due to display stands, adjoining buildings, fences, vehicles or other obstructions.

6.6.4.5 If mercantile operations are conducted in roofed-over areas, these shall be treated as mercantile buildings, provided canopies over individual small stands to protect merchandise from the weather shall not be constructed to constitute buildings for the purpose of the Code.

6.6.5 Exception and Deviation

Any mercantile occupancy, where goods of a highly hazardous nature are pre-dominant, shall be considered under Group J occupancy for the purpose of the Code.

6.7 Requirements of Industrial Buildings (Group G)

6.7.1 In addition to the general requirements specified in **3.4** for the type of construction and occupancy group and the exit requirements given in **4**, the requirements given in **6.7.2** to **6.7.5** shall be complied with.

6.7.2 Fire Detection/Extinguishing System

The requirements for occupancy sub-divisions G-1 to G-3 as specified in Table 23 and Annex C (for High Rise Buildings) shall apply.

6.7.3 Exit Facilities

In addition to the provisions of **4**, the following requirements shall be complied with.

6.7.3.1 Not less than two exits shall be provided for every floor or section, including basements used for industrial purposes or uses incidental thereto.

6.7.3.2 In buildings used for aircraft assembly or other occupancy requiring undivided floor areas so large that the distances from points within the area to the nearest outside walls where exit doors could be provided are in excess of 45 m, requirements for distance to exits may be satisfied by providing stairs leading to exit tunnels or to overhead passageways. In cases where such arrangements are not practicable, the Authority may, by special ruling, permit other exit arrangements for one storey buildings with distances in excess of the maximum distances specified in **4**, if completely automatic sprinkler protection is provided and if the heights of ceiling curtain boards and roof ventilation are such as to minimize the possibility that employees will be overtaken by the spread of fire or smoke within 1 800 mm of the floor level before they have time to reach exits, provided, however, that in no case may the distance of travel to reach the nearest exit exceed 45 m where smoke venting is required as a condition for permitting distances of travel to exits in excess of the maximum otherwise allowed.

6.7.3.3 Additional precautions

- a) In any room in which volatile flammable substances are used or stored, no device generating a glow or flame capable of igniting flammable vapour shall be installed or used. Such a room shall be provided with a suitably designed exhaust ventilation system (*see* Annex D). To ensure safety from fire due to short circuit, faulty electrical connection or some similar cause, proper care shall be taken in designing electrical installations in such room (*see* Part 8 'Building Services, Section 2 Electrical Installations').
- b) The storage, use and handling of gasoline, fuel oil and other flammable liquids shall not be permitted in any Group G occupancy unless it complies with regulations pertaining to *Petroleum Act, 1934* and Rules thereunder.
- c) Every boiler room or room below the first floor containing a heating plant shall be adequately separated from the rest of the buildings.
- d) For requirements regarding electrical generating and distribution stations, reference may be made to good practice [4(23)].

6.7.3.4 Exception and deviation

- a) Basements used only for storage, heating or other service equipment, and not subject to industrial occupancy, shall have exits in accordance with the requirements of Group H occupancies.
- b) The following exceptions shall apply to special purpose industrial occupancies:
 - 1) Exits need be provided only for the persons actually employed; spaces not subject to human occupancy because of the presence of machinery or equipment may be excluded from consideration.
 - 2) Where unprotected vertical openings are necessary to manufacturing operations, these may be permitted beyond the limits specified for industrial occupancy, provided every floor level has direct access to one or more enclosed stairways or other exits protected against obstruction by any fire in the open areas connected by the unprotected vertical openings or smoke therefrom.
 - 3) Industrial buildings of low and moderate hazard are permitted only up to 18 m height.
- c) The following exceptions shall apply to high hazard industrial occupancies:
 - 1) Exits shall be so located that it will not be necessary to travel more than 22.5 m from any point to reach the nearest exit.
 - 2) From every point in every floor area, there shall be at least two exits accessible in different directions; where floor areas are divided into rooms, there shall be at least two ways of escape from every room, however small, except toilet rooms, so located that the points of access thereto are out of or suitably shielded from areas of high hazard.
 - 3) In addition to types of exits for upper floors specified for Group G occupancies, slide escapes may be used as required exits for both new and existing buildings.
 - 4) All high hazard industrial occupancies shall have automatic sprinkler protection or such other protection as may be appropriate to the particular hazard, including explosion venting for any area subject to explosion hazard, designed to minimize danger to occupants in case of fire or other emergency before they have time to utilize exits to escape.

- 5) Industrial buildings of high hazard are permitted only up to 15 m height.

6.7.4 For detailed information on fire safety of certain individual (specific) industrial occupancies reference may be made to good practice [4(39)].

6.7.5 Fire protection considerations for venting industrial occupancies shall be as given in Annex D.

6.8 Requirements of Storage Buildings (Group H)

6.8.1 In addition to the general requirements specified in 3.4 for type of construction and occupancy group and the exit requirements given in 4, the requirements given in 6.8.2 to 6.8.5 shall be complied with.

6.8.2 Fire Detection/Extinguishing System

The requirements for occupancy group H, as specified in Table 23 and Annex C (for High Rise Building) shall apply.

NOTE — Automatic sprinklers are prohibited where water reactive materials are kept. Instead automatic fire alarm system coupled with suitable fire extinguishing systems shall be installed.

6.8.3 Exit Facilities

In addition to the provisions of 4, the following requirements shall also be complied with.

6.8.3.1 Every building or structure used for storage and every section thereof considered separately, shall have access to at least one exit so arranged and located as to provide a suitable means of escape for any person employed therein and in any room or space exceeding 1 400 m² gross area, or where more than 10 persons may be normally present, at least two separate means of exit shall be available, as remote from each other as practicable.

6.8.3.2 Every storage area shall have access to at least two means of exit, which can be readily opened. This shall not be subject to locking so long as any persons are inside and shall not depend on power operation.

6.8.3.3 The following special provisions shall apply to parking garages of closed or open type, above or below ground, but not to mechanical parking facilities where automobiles are moved into and out of storage mechanically which are not normally occupied by persons and thus require no exit facilities. Where repair operations are conducted, the exits shall comply with the requirements of Group G occupancies in addition to compliance with the following:

- a) Where both parking and repair operations are conducted in the same building, the entire building shall comply with the requirements for Group G occupancies, unless the parking

and repair sections are effectively separated by separation walls.

- b) Every floor of every closed parking garage shall have access to at least two separate means of exit, so arranged that from any point in the garage the paths of travel to the two means of exit shall be in different directions, except that a common path of travel may be permitted for the first 15 m, from any point.
- c) On the street floor, at least two separate exit doors shall be provided, except that any opening for the passage of automobiles may serve as a means of exit, provided no door or shutter is installed thereon. Street floor exits in closed garages shall be so arranged that no point in the area is more than 30 m from the nearest exit, or 45 m in the case of garages protected by automatic sprinklers, distance being measured along the natural path of travel.
- d) On floors above the street, at least two means of exit shall be provided, one of which shall be an enclosed stairway. The other means of egress may be a second exit of any of the types, or in a ramp type garage with open ramps not subject to closure, the ramp may serve as the second means of exit.
- e) Upper floor exits in closed garages shall be so arranged that no point in the area shall be more than 30 m from the nearest exit other than a ramp on the same floor level or 45 m in the case of garages protected by automatic sprinklers.
- f) On floors below the street (either basement or outside underground garages) at least two exits shall be provided, not counting any automobile ramps, except that for garages extending only one floor level below the street, a ramp leading direct to the outside may constitute one required means of exit. In garages below street level, exits shall be so arranged that no part of the area shall be more than 30 m from the nearest stair exit.
- g) If any gasoline pumps are located within any closed parking garage, exits shall be so located that travel away from the gasoline pump in any direction shall lead to an exit; with no dead-end in which occupants might be trapped by fire or explosion at any gasoline pump. Such exit shall lead to the outside on the building on the same level, or downstairs; no upward travel shall be permitted unless direct outside exits are available from that floor and any floor below (as in the case of a basement garage where

the grade is one storey or more lower at the rear than at the street).

6.8.3.4 Exits from aircraft hangers (storage or servicing areas) shall be provided at intervals of not more than 45 m on all exterior walls of aircraft hangers. There shall be a minimum of two exits serving each aircraft storage or servicing areas. Horizontal exits through interior fire walls shall be provided at intervals of not more than 30 m. 'Dwarf or 'smash' doors accommodating aircraft may be used to comply with these requirements. All doors designated as exits shall be kept unlocked in the direction of exit travel while the area is occupied.

6.8.3.5 Exits from mezzanine floors in aircraft storage or servicing areas shall be so arranged that the maximum travel to reach the nearest exits from any point on the mezzanine shall not exceed 22.5 m. Such exits shall lead directly to a properly enclosed stairwell discharging directly to the exterior or to a suitably cut-off area or to outside fire escape stairs.

6.8.3.6 The following special provisions shall apply to grain elevators:

- a) There shall be at least one stair tower from basement to first floor and from the first floor to the top floor of workhouse which is enclosed in a dust-tight non-combustible shaft.
- b) Non-combustible doors of self-closing type shall be provided at each floor landing.
- c) An exterior fire escape of the stair or basket ladder type shall be provided from the roof of the workshop to ground level or the roof of an adjoining annexe with access from all floors above the first.
- d) An exterior fire escape of either the stair or basket ladder type shall be provided from the roof of each storage annexe to ground level.

6.8.4 Additional Precautions

Requirements specified in **6.7.3.3** shall apply to Group H occupancies also.

6.8.5 Exceptions and Deviations

Every area used for the storage of hazardous commodities shall have an exit within 22.5 m of any point in the area where persons may be present or 35 m where automatic sprinkler protection is provided.

6.9 Requirements of Buildings for Hazardous Uses (Group J)

6.9.1 In addition to the general requirements specified in **3.4** for type of construction and occupancy group and the exit requirements given in **4**, the requirements given in **6.9.2** to **6.9.4** shall be complied with.

6.9.2 Fire Detection/Extinguishing System

The requirements for occupancy Group J, as specified in Table 23 and Annex C (for High Rise Building) shall apply.

NOTE — Hazardous buildings shall have vapour detectors/explosion suppression systems/automatic sprinklers, besides hydrant system, wet risers and automatic fire alarm system depending on the type of fire hazard involved.

6.9.3 Exit Facilities

Requirements specified in 4 and 6.7.3.4 (c) shall apply to Group J occupancies also.

6.9.4 Additional Precautions

The following requirements shall apply to all Group J occupancies, as applicable:

- a) Each building where gas is employed for any purpose shall be provided with an approved outside gas shut-off valve conspicuously marked. The detailed requirements regarding safe use of gas shall be as specified in Part 9 'Plumbing Services, Section 2 Gas Supply'.
- b) Each boiler room or room containing a heating plant shall be separated from the rest of the building by a separating wall.
- c) In any room in which volatile flammable substances are used or stored, no device generating a spark, or glow flame capable of igniting flammable vapour shall be installed or permitted unless it is enclosed in a flameproof enclosure.
- d) The use, handling, storage and sale of gasoline, fuel oil and other flammable liquids shall not be permitted in Group J occupancies unless such use, handling, storage and sale is in accordance with appropriate legislation in force.
- e) All openings in exterior walls except wall vents shall be protected by a fire stop assembly as in 4 and they shall be fixed, automatic or self-closing. Wall vents having an area of not less than 100 cm² each shall be placed in the exterior walls near the floor line, not more than 1 800 mm apart horizontally. Each building shall be provided with a power driven fan exhaust system of ventilation which shall be arranged and operated so as to produce a complete change of air in each room every 3 min.
- f) Each machine in dry-cleaning establishments which uses flammable liquid shall have an adequate steam line or any other suitable extinguishing agent directly connected to it, so arranged as to have the agent automatically released to the inside of each machine should an explosion occur in the machine.
- g) Equipment or machinery which generates or emits combustible or explosive dust or fibres shall be provided with an adequate dust collecting and exhaust system.

ANNEX A

(Clause 3.1.8)

CALORIFIC VALUES OF COMMON MATERIALS AND TYPICAL VALUES OF FIRE LOAD DENSITY

A-1 The calorific values of some common materials are given in Table 25 for guidance.

Table 25 Calorific Values of Common Materials

Material (1)	Calorific Value (10 ³ kJ/kg ⁻¹) ¹⁾ (2)	Wood Equivalent (kg/kg) (3)
Solid Fuels		
Anthracite	28.6	1.66
Bituminous Coal	30.8	1.75
Charcoal	28.4	1.61
Coke (average)	27.5	1.56
Peats	20.9	1.19
Sub-bituminous Coal	22.0	1.25
Woods (hard or softwood)	17.6	1.00
Hydrocarbons		
Benzene	39.6	2.25
Butane	47.1	2.68
Ethane	49.1	2.79
Ethylene	47.7	2.71
Fuel Oil	41.6	2.36
Gas Oil	42.9	2.44
Hexane	44.9	2.55
Methane (natural gas)	52.8	3.00
Octane	45.3	2.58
Paraffin	39.6-44.0	2.3-2.5
Pentane	46.0	2.61
Propane	47.3	2.69
Propylene	46.2	2.63
Alcohols		
Ethyl Alcohol	28.4	1.61
Methyl Alcohol	21.1	1.20
Propyl Alcohol	31.9	1.81
Polymers		
Casein	23.1	1.31
Cellulose	16.5	0.94
Cellulose Acetate	17.8	1.01
Polyethylene	48.4	2.75
Polypropylene	48.4	2.75
Polystyrene	41.8	2.38
Polyvinylchloride	20.9	1.19
Polymethylmethacrylate	24.6	1.40
Polyurethane	35.2	2.00
Polyamide (nylon)	22.0	1.25
Polyester	22.0	1.25
Common Solids		
Asphalt	38.3	2.13
Bitumen	33.4	1.90
Carbon	32.1	1.83
Cotton (Dry)	15.8	0.90
Flax	14.3	0.81
Furs and Skins	18.7	1.06
Hair (animal)	20.9	1.19
Leather	17.6	1.00

Table 25 — Concluded

(1)	(2)	(3)
Ozokerite (wax)	43.3	2.46
Paper (average)	15.4	0.88
Paraffin wax	40.9	2.33
Pitch	33.0	1.88
Rubber	37.4	2.13
Straw	13.2	0.75
Tallows	37.6	2.14
Tan bark	20.9	1.19
Tar (bituminous)	35.2	2.00
Wool (raw)	21.6	1.23
Wool (scoured)	19.6	1.11
Foodstuffs		
Barely	14.1	0.80
Bran	11.0	0.63
Bread	9.9	0.56
Butter	29.5	1.68
Cheese (Cheddar)	18.1	1.03
Cornmeal	14.1	0.80
Flour	14.1	0.80
Margarine	29.5	1.68
Oatmeal	15.8	0.90
Rice	13.9	0.79
Soyabean Flour	16.1	0.91
Sugar	15.4	0.88
Whole Wheat	14.3	0.81
Miscellaneous		
Acetone	29.7	1.69
Acetaldehyde	25.1	1.43
Formaldehyde	17.6	1.00
Hydrogen	134.2	7.63
Magnesium	24.0	1.36

¹⁾ 1 kJ is approximately equal to 1 Btu so the figures in the tables are also equivalent to Btu/kg.

A-2 The typical values fire load density for arriving at the classification of occupancy hazard is given in Table 26 for guidance.

Table 26 Typical Values of Fire Load Density

Sl No.	Building Type	Fire Load Density (Expressed as Wood Equivalent kg/m ²)
(1)	(2)	(3)
i)	Residential (A-1 and A-2)	25
ii)	Residential (A-3 to A-5)	25
iii)	Institutional and Educational (B and C)	25
iv)	Assembly (D)	25-50
v)	Business (E)	25-50
vi)	Mercantile (F)	Up to 250
vii)	Industrial (G)	Up to 150
viii)	Storage and Hazardous (H and J)	Up to 500

ANNEX B

(Clauses 3.1.8 and 3.1.11)

BROAD CLASSIFICATION OF INDUSTRIAL AND NON-INDUSTRIAL OCCUPANCIES INTO DIFFERENT DEGREE OF HAZARD

B-1 LOW HAZARD OCCUPANCIES

Abrasive manufacturing premises
Aerated water factories
Agarbatti manufacturing premises
Analytical and/or Q.C. Laboratories
Arecanut slicing and/or Betelnut factories
Asbestos steam packing and lagging manufacturers
Assembly buildings small (D-4 and D-5)
Battery charging and service stations
Battery manufacturing
Breweries
Brickworks
Canning factories
Cardamom factories
Cement factories and/or asbestos or concrete products manufacturing premises
Ceramic factories, crockery, stoneware pipe manufacturing
Clay works
Clock and watch manufacturing
Clubs
Coffee curing, roasting and grinding factories
Condensed milk factories, milk pasturising plants and dairies
Confectionary manufacturing
Dwellings, lodges, dormitories, etc
Educational and research institutions
Electric lamps (incandescent and fluorescent) and T.V. tube manufacturing
Electroplating works
Engineering workshops
Fruits and vegetables dehydrating and drying factories
Fruits products and condiment factories
Glass and glass fibre manufacturing
Godowns and warehouses (non-combustible goods)
Gold thread/gilding factories
Gum and/or glue and gelatine manufacturing
Ice candy and ice-cream and ice factories
Ink (excluding printing ink) factories
Mica products manufacturing

Office premises
Places of worship
Pottery works
Poultry farms
Residential buildings (A-1 to A-4) (except hotels A-5)
Salt crushing factories/refineries stables
Sugar candy manufacturing
Sugar factories and refineries
Tanneries
Umbrella assembling factories
Vermicelli factories
Water treatment/filtration plants and water pump houses
Zinc/copper factories

B-2 MODERATE HAZARD OCCUPANCIES

Airport and other transportation terminal buildings
Aluminium factories
Assembly buildings (D-1 to D-3)
Atta and cereal grinding
Bakeries and biscuit factories
Beedi factories
Bobbin factories
Book-binders, envelopes and paper bag manufacturing
Cable manufacturing
Camphor boiling
Candle works
Carbon paper/typewriter ribbon makers
Card board box manufacturing
Carpenters, wood wool and furniture makers
Carpet and durries factories
Cashewnut factories
Chemical manufacturers (using raw materials having F.P > 23°C)
Cigar and cigarette factories
Coir factories
Cold storage premises
Computer installations
Cork products manufacturing (coir, carpets, rugs and tobacco) (hides and skin presses)
Dry cleaning, dyeing and laundries
Electric sub-stations/distribution stations

Electrical generating stations except under ground powerhouses
 Enamelware factories
 Filler and wax paper manufacturing
 Flour mills
 Garment makers
 Ghee factories (other than vegetable)
 Godowns and warehouses (other than non-combustible goods)
 Grains and seed disintegrating or crushing
 Grease manufacturing
 Hosiery, lace, embroidery and thread
 Hospitals including 'X'-ray and other diagnostic clinics (institutional buildings)
 Incandescent gas mantle manufacturers
 Industrial gas manufacturing (only halogenated hydrocarbons/inert gases)
 Man-made yarn/fibre (except acrylic fibre/yarn)
 Manure and fertilizer works (blending, mixing and granulating only)
 Mercantile occupancies (departmental stores, shopping complex, etc)
 Mineral oil blending and processing
 Museums, archives, record rooms
 Oil and leather cloth factories
 Open storage of flammable liquids (in drums, cans, etc)
 Oxygen plants
 Paper and cardboard mills (except raw material yard)
 Piers, wharves, dockyards
 Plastic goods manufacturing
 Plywood/wood veneering factories
 Printing press premises
 Pulverizing and crushing mills
 Residential apartments, hotels, cafes, restaurants
 Rice mills
 Rope works
 Rubber goods manufacturing
 Rubber tyres and tubes manufacturing
 Shellac factories
 Silk filatures
 Soaps and glycerine factories
 Spray painting
 Starch factories
 Tea factories (including blending packing of tea)
 Telephone exchanges, garages
 Textile mills

Tobacco chewing and pan masala making
 Tobacco re-drying factories
 Woolen mills

B-3 HIGH HAZARD OCCUPANCIES

A)

Aircraft hangers
 Aluminium/magnesium powder plants
 Bitumanized paper/hessian cloth/tar felt manufacturing
 Bulk storage of flammable liquids (tank farm, etc)
 Celluloid goods making
 Chemical manufacturers (where raw materials have a F.P. < 23°C)
 Cigarette filter manufacturing
 Cinema films and T.V. production studios
 Coal, coke and charcoal ball and briquettes making
 Collieries, steel plants
 Cotton seeds cleaning and delinting factories
 Cotton waste factories
 Distilleries
 Duplicating/stencil paper making
 Fire works manufacture
 Foamed plastic and/or converting plants
 Godowns of warehouses (combustible/hazardous goods) (H)
 Grass, hay, fodder and *BHOOSA* (chaff)
 Hazardous occupancy buildings (J)
 Industrial gas manufacturing (except halogenated hydrocarbon gases/inert gases)
 Industrial units (G-3 occupancies)
 Jute mills and jute presses
 Linoleum factories
 Man-made fibres (only acrylic fibre/yarn making)
 Match factories
 Mattress and pillow makings (foam plastics)
 Metal or tin printers (if more than 50 percent is engineering, shift to ordinary hazard)
 Oil mills
 Oil extraction plants
 Oil terminals/depots
 Paints/Varnish factories
 Paper and cardboard mills (only raw material yard)
 Pressing factories
 Printing ink making
 Resin, lamp black and turpentine manufacture
 Saw mills

Surgical cotton manufacturing
Tarpaulin and canvas proofing factories
Turpentine and resin distilleries
Tyre retreading and resolving factories
Underground shopping complexes (F-3)

B)

Ammonia and urea synthesis plants

Explosive factories
LPG bottling plants
Petrochemical plants
Petroleum refineries

NOTE — In case of complexes having segregated plants with varying degrees of hazards, the competent authority having jurisdictions shall be consulted to decide the level of protections to be provided.

ANNEX C

(Clauses 3.4.11.1, 4.18.2, 5.1.8, 5.2.2, 6.1.2, 6.2.3, 6.3.2, 6.4.3, 6.5.2, 6.6.2, 6.7.2, 6.8.2 and 6.9.2)

FIRE PROTECTION REQUIREMENTS FOR HIGH RISE BUILDINGS — 15 m IN HEIGHT OR ABOVE

C-0 GENERAL

In addition to the general provisions given in this Part, the Authority may insist on suitable protection measures (*see C-1 to C-11*) in a building 15 m in height or above.

C-1 CONSTRUCTION

C-1.1 All materials of constructions in load bearing elements, stairways and corridors and facades shall be non-combustible.

C-1.2 The interior finish materials shall not have a flame spreadability rating exceeding Class 1 (*see 3.4.15.2*).

C-1.3 The internal walls or staircase shall be of brick or reinforced concrete with a minimum of 2 h fire rating.

C-1.4 The staircase shall be ventilated to the atmosphere at each landing and a vent at the top; the vent openings shall be of 0.5 m² in the external wall and the top. If the staircase cannot be ventilated, because of location or other reasons, a positive pressure 50 Pa shall be maintained inside. The mechanism for pressurizing the staircase shall operate automatically with the fire alarm. The roof of the shaft shall be 1 m above the surrounding roof. Glazing or glass bricks if used in staircase, shall have fire resistance rating of minimum 2 h.

C-1.5 Lifts

General requirements of lifts shall be as follows:

- a) Walls of lift enclosures shall have a fire rating of 2 h; lifts shafts shall have a vent at the top of area not less than 0.2 m².
- b) Lift motor room shall be located preferably

on top of the shaft and separated from the shaft by the floor of the room.

- c) Landing doors in lift enclosures shall have a fire resistance of not less than 1 h.
- d) The number of lifts in one row for a lift bank shall not exceed 4 and the total number of lifts in the bank (of two rows) shall not exceed 8. A wall of 2 h fire rating shall separate individual shafts in a bank.
- e) Lift car door shall have a fire resistance rating of half an hour.
- f) Collapsible gates shall not be permitted for lifts and shall have solid doors with fire resistance of at least 1 h.
- g) If the lift shaft and lobby is in the core of the building, a positive pressure between 25 and 30 Pa shall be maintained in the lobby and a positive pressure of 50 Pa shall be maintained in the lift shaft. The mechanism for pressurization shall act automatically with the fire alarm; it shall be possible to operate this mechanically also.
- h) Exit from the lift lobby, if located in the core of the building, shall be through a self-closing smoke stop door of half an hour fire resistance.
- j) Lifts shall not normally communicate with the basement; if, however, lifts are in communication, the lift lobby of the basements shall be pressurized as in (g), with self-closing door as in (h).
- k) Grounding switch(es), at ground floor level, shall be provided on all the lifts to enable the fire service to ground the lifts.
- m) Telephone or other communication facilities

shall be provided in lift cars for building of 30 m in height and above. Communication system for lifts shall be connected to fire control room for the building.

- n) Suitable arrangements such as providing slope in the floor of lift lobby, shall be made to prevent water used during fire fighting, etc, at any landing from entering the lift shafts.
- p) A sign shall be posted and maintained on every floor at or near the lift indicating that in case of fire, occupants shall use the stairs unless instructed otherwise. The sign shall also contain a plan for each floor showing the locations of the stairways.

Alternate source of power supply shall be provided for all the lifts through a manually operated changeover switch.

- q) *Fire Lifts* — Following details shall apply for a fire lift:
 - 1) To enable fire services personnel to reach the upper floors with the minimum delay, one fire lift per 1 200 m² of floor area shall be provided and shall be available for the exclusive use of the firemen in an emergency.
 - 2) The lift shall have a floor area of not less than 1.4 m². It shall have loading capacity of not less than 545 kg (8 persons lift) with automatic closing doors of minimum 0.8 m width.
 - 3) The electric supply shall be on a separate service from electric supply mains in a building and the cables run in a route safe from fire, that is, within the lift shaft. Lights and fans in the elevators having wooden paneling or sheet steel construction shall be operated on 24 V supply.
 - 4) Fire fighting lift should be provided with a ceiling hatch for use in case of emergency, so that when the car gets stuck up, it shall be easily openable.
 - 5) In case of failure of normal electric supply, it shall automatically trip over to alternate supply. For apartment houses, this changeover of supply could be done through manually operated changeover switch. Alternatively, the lift shall be so wired that in case of power failure, it comes down at the ground level and comes to stand-still with door open.
 - 6) The operation of a fire lift is by a simple toggle or two-button switch situated in a glass-fronted box adjacent to the lift at

the entrance level. When the switch is on, landing call-points will become inoperative and the lift will be on car control only or on a priority control device. When the switch is off, the lift will return to normal working. This lift can be used by the occupants in normal times.

- 7) The words 'Fire Lift' shall be conspicuously displayed in fluorescent paint on the lift landing doors at each floor level.
- 8) The speed of the fire lift shall be such that it can reach the top floor from ground level within 1 min.

C-1.6 Basements

C-1.6.1 Each basement shall be separately ventilated. Vents with cross-sectional area (aggregate) not less than 2.5 percent of the floor area spread evenly round the perimeter of the basement shall be provided in the form of grills, or breakable stallboard lights or pavement lights or by way of shafts. Alternatively, a system of air inlets shall be provided at basement floor level and smoke outlets at basement ceiling level. Inlets and extracts may be terminated at ground level with stallboard or pavement lights as before, but ducts to convey fresh air to the basement floor level have to be laid. Stallboard and pavement lights should be in positions easily accessible to the fire brigade and clearly marked 'SMOKE OUTLET' or 'AIR INLET' with an indication of area served at or near the opening.

C-1.6.2 The staircase of basements shall be of enclosed type having fire resistance of not less than 2 h and shall be situated at the periphery of the basement to be entered at ground level only from the open air and in such positions that smoke from any fire in the basement shall not obstruct any exit serving the ground and upper stores of the building and shall communicate with basement through a lobby provided with fire resisting self closing doors of 1 h resistance. For travel distance *see* 4.5. If the travel distance exceeds as given in Table 21, additional staircases shall be provided at proper places.

C-1.6.3 In multi-storey basements, intake ducts may serve all basement levels, but each basement levels and basement compartment shall have separate smoke outlet duct or ducts. Ducts so provided shall have the same fire resistance rating as the compartment itself. Fire rating may be taken as the required smoke extraction time for smoke extraction ducts.

C-1.6.4 Mechanical extractors for smoke venting system from lower basement levels shall also be provided. The system shall be of such design as to

operate on actuation of heat/smoke sensitive detectors or sprinklers, if installed, and shall have a considerably superior performance compared to the standard units. It shall also have an arrangement to start it manually.

C-1.6.4.1 Mechanical extractors shall have an internal locking arrangement, so that extractors shall continue to operate and supply fans shall stop automatically with the actuation of fire detectors.

C-1.6.4.2 Mechanical extractors shall be designed to permit 30 air changes per hour in case of fire or distress call. However, for normal operation, air changes schedule shall be as given in **3.4.11.5**.

C-1.6.4.3 Mechanical extractors shall have an alternative source of supply.

C-1.6.4.4 Ventilating ducts shall be integrated with the structure and made out of brick masonry or reinforced cement concrete as far as possible and when this duct crosses the transformer area or electrical switchboard, fire dampers shall be provided.

C-1.6.5 Use of basements for kitchens working on gas fuel shall not be permitted, unless air conditioned.

The basement shall not be permitted below the ward block of a hospital/nursing home unless it is fully sprinkled.

Building services such as electrical sub-stations, boiler rooms in basements shall comply with the provisions of the *Indian Electricity Act/Rules*.

C-1.6.6 If cut outs are provided from basements to the upper floors or to the atmospheres, all sides cut out openings in the basements shall be protected by sprinkler head at close spacing so as to form a water curtain in the event of a fire.

C-1.7 Openable windows on external walls shall be fitted with such locks that can be opened by a fireman's axe.

C-1.8 All floors shall be compartmented with area not exceeding 750 m² by a separation wall with 2 h fire rating, for floors with sprinklers the area may be increased by 50 percent. In long building, the fire separation walls shall be at distances not exceeding 40 m. For departmental stores, shopping centres and basements, the area may be reduced to 500 m² for compartmentation. Where this is not possible, the spacings of the sprinklers shall be suitably reduced. When reducing the spacing of sprinklers, care should be taken to prevent spray from one sprinkler impeding the performance of an adjacent sprinkler head.

C-1.8.1 It is essential to make provisions for drainage of any such water on all floors to prevent or minimize water damage of the contents. The drain pipes should be provided on the external wall for drainage of water

from all floors. On large area floors several such pipes may be necessary which should be spaced 30 m apart. Care shall be taken to ensure that the construction of the drain pipe does not allow spread of fire/smoke from floor to floor.

C-1.9 Service Ducts/Shafts

- a) Service ducts and shafts shall be enclosed by walls of 2 h and doors of 1 h, fire rating. All such ducts/shafts shall be properly sealed and fire stopped at all floor levels.
- b) A vent opening at the top of the service shaft shall be provided having between one-fourth and one-half of the area of the shaft.

C-1.10 Refuse chutes shall have opening at least 1 m above roof level or venting purpose and they shall have an enclosure wall of non-combustible material with fire resistance of not less than 2 h. They shall not be located within the staircase enclosure or service shafts, or air-conditioning shafts inspection panel and doors shall be tight fitting with 1 h fire resistance; the chutes should be as far away as possible from exits.

C-1.11 Refuge Area

Provisions contained in **4.12.3** shall apply for all buildings except multi-family dwellings, refuge area of not less than 15 m² shall be provided on the external walls.

C-1.12 Electrical services shall conform to the following:

- a) The electric distribution cables/wiring shall be laid in a separate duct. The duct shall be sealed at every floor with non-combustible materials having the same fire resistance as that of the duct. Low and medium voltage wiring running in shaft and in false ceiling shall run in separate conduits;
- b) Water mains, telephone lines, intercom lines, gaspipes or any other service line shall not be laid in the duct for electrical cables; use of bus ducts/solid rising mains instead of cables is preferred;
- c) Separate circuits for fire fighting pumps, lifts, staircases and corridor lighting and blowers for pressurizing system shall be provided directly from the main switch gear panel and these circuits shall be laid in separate conduit pipes, so that fire in one circuit will not affect the others. Such circuits shall be protected at origin by an automatic circuit breaker with its no-volt coil removed. Master switches controlling essential service circuits shall be clearly labelled;

- d) The inspection panel doors and any other opening in the shaft shall be provided with air-tight fire doors having fire resistance of not less than 2 h;
- e) Medium and low voltage wiring running in shafts, and within false ceiling shall run in metal conduit. Any 230 V wiring for lighting or other services, above false ceiling, shall have 660 V grade insulation. The false ceiling, including all fixtures used for its suspension, shall be of non-combustible material and shall provide adequate fire resistance to the ceiling in order to prevent spread of fire across ceiling reference may be made to good practice [4(29)];
- f) An independent and well ventilated service room shall be provided on the ground level or first basement with direct access from outside or from the corridor for the purpose of termination of electric supply from the licensees' service and alternative supply cables. The doors provided for the service room shall have fire resistance of not less than 2 h;

NOTE — If service room is located at the first basement, it should have automatic fire extinguishing system.

- g) If the licensees agree to provide meters on upper floors, the licensees' cables shall be segregated from consumers' cables by providing a partition in the duct. Meter rooms on upper floors shall not open into stair case enclosures and shall be ventilated directly to open air outside; and
- h) Suitable circuit breakers shall be provided at the appropriate points.

C-1.13 Gas supply shall conform to the following:

- a) *Town Gas/L.P. Gas Supply Pipes* — Where gas pipes are run in buildings, the same shall be run in separate shafts exclusively for this purpose and these shall be on external walls, away from the staircases. There shall no interconnection of this shaft with the rest of the floors. LPG distribution pipes shall always be below the false ceiling. The length of these pipes shall be as short as possible. In the case of kitchen cooking range area, apart from providing hood, covering the entire cooking range, the exhaust system should be designed to take care of 30 m³ per minute per m² of hood protected area. It should have grease filters using metallic grill to trap oil vapours escaping into the fume hood.

NOTE — For detailed information on gas pipe installations, reference may be made to Part 9 'Plumbing Services, Section 3 Gas Supply'.

- b) All wiring in fume hoods shall be of fibre glass insulation. Thermal detectors shall be installed into fume hoods of large kitchens for hotels, hospitals, and similar areas located in high rise buildings. Arrangements shall be made for automatic tripping of the exhaust fan in case of fire. If LPG is used, the same shall be shut off. The voltage shall be 24 V or 100 V dc operated with external rectifier. The valve shall be of the hand re-set type and shall be located in an area segregated from cooking ranges. Valves shall be easily accessible. The hood shall have manual facility for steam or carbon dioxide gas injection, depending on duty condition; and
- c) Gas meters shall be housed in a suitably constructed metal cupboard located in a well ventilated space, keeping in view the fact that LPG is heavier than air and town gas is lighter than air.

C-1.14 Illumination of Means of Exit

Staircase and corridor lights shall conform to the following (*see 4.16 and 4.17* for additional details):

- a) The staircase and corridor lighting shall be on separate circuits and shall be independently connected so as it could be operated by one switch installation on the ground floor easily accessible to fire fighting staff at any time irrespective of the position of the individual control of the light points, if any. It should be of miniature circuit breaker type of switch so as to avoid replacement of fuse in case of crisis;
- b) Staircase and corridor lighting shall also be connected to alternative supply. The alternative source of supply may be provided by battery continuously trickle charged from the electric mains;
- c) Suitable arrangements shall be made by installing double throw switches to ensure that the lighting installed in the staircase and the corridor does not get connected to two sources of supply simultaneously. Double throw switch shall be installed in the service room for terminating the stand-by supply;
- d) Emergency lights shall be provided in the staircase and corridor; and
- e) All wires and other accessories used for emergency light shall have fire retardant property.

C-1.15 A stand-by electric generator shall be installed to supply power to staircase and corridor lighting circuits, fire lifts, the stand-by fire pump, pressurization

fans and blowers, smoke extraction and damper systems in case of failure of normal electric supply. The generator shall be capable of taking starting current of all the machines and circuits stated above simultaneously. If the stand-by pump is driven by diesel engine, the generator supply need not be connected to the stand-by pump. Where parallel HV/LV supply from a separate sub-station is provided with appropriate transformer for emergency, the provision of generator may be waived in consultation with the Authority.

C-1.16 Transformers shall conform to the following:

- a) A sub-station or a switch-station with oil filled equipment shall not be located in the building. The sub-station structure shall have separate fire resisting walls/surroundings and shall necessarily be located at the periphery of the floor having separate access from fire escape stair case. The outside walls, ceiling, floor, openings including doors and windows to the sub-station area shall be provided with a fire resisting door of 2 h fire rating. Direct access to the transformer room shall be provided, preferably from outside fire escape staircase.
- b) The sub-station area needs to be maintained at negative air pressures and area in sub-station shall not be used as storage/dump areas.
- c) When housed inside the building, the transformer shall be of dry type and shall be cut off from the other portion of premises by walls/doors/cutout having fire resistance rating of 4 h.

C-1.17 Air-conditioning shall conform to the following:

- a) Escape routes like staircases, common corridors, lift lobbies, etc, shall not be used as return air passage.
- b) The ducting shall be constructed of substantial gauge metal in accordance with good practice [4(31)].
- c) Wherever the ducts pass through fire walls or floors, the opening around the ducts shall be sealed with materials having fire resistance rating of the compartment.
- d) Where duct crosses a compartment which is fire rated, the ducts shall be fire rated for same fire rating. Further depending on services passing around the duct work, which may get affected in case of fire temperature rising, the ducts shall be insulated.
- e) As far as possible, metallic ducts shall be used even for the return air instead of space above the false ceiling.
- f) Where plenum is used for return air passage,

ceiling and its fixtures shall be of non-combustible material.

- g) The materials used for insulating the duct system (inside or outside) shall be of non-combustible materials. Glass wool shall not be wrapped or secured by any material of combustible nature.
- h) Area more than 750 m² on individual floor shall be segregated by a fire wall and automatic fire dampers for isolation shall be provided [see (j)].
- j) Air ducts serving main floor areas, corridors, etc, shall not pass through the staircase enclosure.
- k) The air-handling units shall be separate for each floor and air ducts for every floor shall be separated and in no way inter-connected with the ducting of any other floor.
- m) If the air-handling unit serves more than one floor, the recommendations given above shall be complied with in addition to the conditions given below:
 - 1) proper arrangements by way of automatic fire dampers working on smoke detector/ or fusible link for isolating all ducting at every floor from the main riser shall be made.
 - 2) When the automatic fire alarm operates, the respective air-handling units of the air-conditioning system shall automatically be switched off.
- n) The vertical shaft for treated fresh air shall be of masonry construction.
- p) The air filters of the air-handling units shall be of non-combustible materials.
- q) The air-handling unit room shall not be used for storage of any combustible materials.
- r) Inspection panels shall be provided in the main trunking to facilitate the cleaning of ducts of accumulated dust and to obtain access for maintenance of fire dampers.
- s) No combustible material shall be fixed nearer than 150 mm to any duct unless such duct is properly enclosed and protected with non-combustible material (glass wool or spunglass with neoprene facing enclosed and wrapped with aluminium sheeting) at least 3.2 mm thick and which would not readily conduct heat.
- t) *Fire Dampers*
 - 1) These shall be located in conditioned air ducts and return air ducts/passages at the following points:
 - i) At the fire separation wall.

- ii) Where ducts/passages enter the central vertical shaft.
 - iii) Where the ducts pass through floors.
 - iv) At the inlet of supply air duct and the return air duct of each compartment on every floor.
- 2) The dampers shall operate automatically and shall simultaneously switch off the air-handling fans. Manual operation facilities shall also be provided.
- NOTE — For blowers, where extraction system and duct accumulators are used, dampers shall be provided.
- 3) Fire/smoke dampers (for smoke extraction shafts) for buildings more than 24 m in height.
- | | |
|----------------------|--|
| For apartment houses | In non-ventilated lobbies/ corridors operated by fusible link/smoke detectors and with manual control. |
| For other buildings | On operation of smoke detection system and with manual control. |
- 4) Automatic fire dampers shall be so arranged as to close by gravity in the direction of air movement and to remain tightly closed on operation of a fusible link/smoke detector.

C-1.18 Provisions of boiler and boiler rooms shall conform to Indian Boiler Act. Further, the following additional aspects may be taken into account in the location of boiler room:

- a) The boilers shall not be allowed in sub-basement, but may be allowed in the basements away from the escape routes.
- b) The boilers shall be installed in a fire resisting room of 4 h fire resistance rating, and this room shall be situated on the periphery of the basement. Catch-pits shall be provided at the low level.
- c) Entry to this room shall be provided with a composite door of 2 h fire resistance.
- d) The boiler room shall be provided with fresh air inlets and smoke exhausts directly to the atmosphere.
- e) The furnace oil tank for the boiler, if located in the adjoining room shall be separated by fire resisting wall of 4 h rating. The entrance to this room shall be provided with double composite doors. A curb of suitable height shall be provided at the entrance in order to

prevent the flow of oil into the boiler room in case of tank rupture.

- f) Foam inlets shall be provided on the external walls of the building near the ground level to enable the fire services to use foam in case of fire.

C-2 PROVISION OF FIRST-AID FIRE FIGHTING APPLIANCES

The first-aid fire fighting equipment shall be provided on all floors, including basements, lift rooms, etc, in accordance with good practice [4(21)] in consultation with the Authority.

C-3 FIRE ALARM SYSTEM

C-3.1 All buildings with heights of 15 m or above shall be equipped with manually operated electrical fire alarm (MOEFA) system and automatic fire alarm system in accordance with good practice [4(18)] and [4(19)]. However, apartment buildings between 15 m and 30 m in height may be exempted from the installation of automatic fire alarm system provided the local fire brigade is suitably equipped for dealing with fire in a building of 15 m in height or above and in the opinion of the Authority, such building does not constitute a hazard to the safety of the adjacent property or occupants of the building itself.

C-3.1.1 Manually operated electrical fire alarm system shall be installed in a building with one or more call boxes located at each floor. The call boxes shall conform to good practice [4(18)] and [4(19)].

C-3.1.2 The installation of call boxes in hostels and such other places where these are likely to be misused shall as far as possible be avoided. Location of call boxes in dwelling units shall preferably be inside the building.

C-4 LIGHTNING PROTECTION OF BUILDINGS

The lightning protection for buildings shall be provided as given in Part 8 'Building Services, Section 2 Electrical Installations'.

C-5 FIRE CONTROL ROOM

For all buildings 15 m in height or above and apartment buildings with a height of 30 m and above, there shall be a control room on the entrance floor of the building with communication system (suitable public address system) to all floors and facilities for receiving the message from different floors. Details of all floor plans along with the details of fire fighting equipment and installations shall be maintained in the fire control room. The fire control room shall also have facilities to detect the fire on any floor through indicator boards connection; fire detection and alarm systems on all floors. The fire staff incharge of the fire control room

shall be responsible for the maintenance of the various services and fire fighting equipment and installations in co-ordination with security, electrical and civil staff of the building.

C-6 FIRE OFFICER FOR HOTELS, BUSINESS AND MERCANTILE BUILDINGS WITH HEIGHT MORE THAN 30 m

C-6.1 A qualified Fire Officer with experience of not less than 3 years shall be appointed who will be available on the premises.

C-6.2 The Fire Officer shall:

- a) maintain the fire fighting equipment in good working condition at all times,
- b) prepare fire orders and fire operational plans and get them promulgated,
- c) impart regular training to the occupants of the buildings in the use of fire fighting equipments provided on the premises and keep them informed about the fire emergency evacuation plan,
- d) keep proper liaison with city Fire Brigade, and
- e) ensure that all fire precautionary measures are observed at the times.

NOTE — Competent authority having jurisdiction may insist on compliance of the above rules in case of buildings having very large areas even if the height is less than 30 m.

C-7 HOUSE KEEPING

To eliminate fire hazards, good house keeping, both

inside and outside the building, shall be strictly maintained by the occupants and/or the owner of the building.

C-8 FIRE DRILLS AND FIRE ORDERS

Fire notices/orders shall be prepared to fulfil the requirements of fire fighting and evacuation from the buildings in the event of fire and other emergency. The occupants shall be made thoroughly conversant with their actions in the event of emergency, by displaying fire notices at vantage points and also through regular training. Such notices should be displayed prominently in broad lettering.

For guidelines for fire drills and evacuation procedures for high rise buildings, *see* Annex E.

C-9 COMPARTMENTATION

The building shall be suitably compartmentalized so that fire/smoke remain confined to the area where fire incident has occurred and does not spread to the remaining part of the building.

C-10 HELIPAD

For high rise buildings above 60 m in height, provision for helipad should be made.

C-11 MATERIALS FOR INTERIOR DECORATION/FURNISHING

The use of materials which are combustible in nature and may spread toxic fume/gases should not be used for interior decoration/furnishing, etc.

ANNEX D

(Clauses 6.7.3.3 (a) and 6.7.5)

FIRE PROTECTION CONSIDERATIONS FOR VENTING IN INDUSTRIAL BUILDINGS

D-1 APPLICATION AND SCOPE

D-1.1 The provisions given below are applicable only to single storey industrial buildings (factories and storage buildings) covering large floor areas without sub-dividing/separating walls which are usually designed to meet modern production methods.

D-1.2 The requirements of fire and explosion venting of industrial buildings, as dealt with in this section, fall under two categories:

- a) Smoke and fire venting, and
- b) Explosion relief vents.

D-2 SMOKE AND FIRE VENTING

D-2.1 The basic considerations for formulating the design and other requirements for smoke and fire vents are as given in **D-2.1.1** to **D-2.1.20**.

D-2.1.1 The smoke and hot combustion products from a fire, being lighter than the surrounding air, tend to rise and on reaching the roof or ceiling spread out (mushroom) on all sides and form a layer which floats on top of the cold air beneath. In the absence of vents, this layer becomes progressively deeper until the whole building is filled with hot smoky gases. The time consumed for this to happen may be only a few

minutes, depending on variables like, type of materials on fire, process/storage conditions involved, etc.

D-2.1.2 The hot gases at the roof level moved by convection currents contribute to rapid lateral spread of fire.

D-2.1.3 The provision of properly designed and suitably located vents in adequate number helps the speedy removal of smoke and hot gases, thereby preventing spread of fire, besides reducing risks of explosion of unburnt gases and reducing damage to the contents and structure of the building by heat and smoke. In addition, they facilitate fire fighting operations, and minimize personal hazards to the firemen.

D-2.1.4 The time taken for accumulation of smoke and hot gases within a building on fire being very short, the venting devices installed shall be designed to operate in the early stage of the fire and must be automatic so as to ensure speed and efficiency in their operation.

D-2.1.5 The smoke and fire venting system shall be designed in such a manner as to keep the temperature of the combustion products from the fire as low as possible, preferably below approximately 150°C.

D-2.1.6 Automatic venting systems are complementary to the fire extinguishing systems, and automatic sprinklers, where provided, should operate before the operation of the vents; otherwise, venting may delay sprinkler operation.

D-2.1.7 It is easier to vent a building of smoke than clear it of smoke once it has been filled.

D-2.1.8 Venting is particularly desirable in large area industrial buildings or warehouses, windowless buildings, underground structures or in areas housing hazardous operations. Automatic fire vents shall be provided for all industrial occupancies (including storage buildings) classified as medium hazard or above having floor areas exceeding 750 m², irrespective of whether they are compartmentalized or not.

D-2.1.9 These provisions do not cover other aspects, of ventilation (or lighting) designed for regulation of temperature within a building for personal comfort or meeting process needs.

D-2.1.10 Similarly, fire and smoke venting requirements as given here under are also not applicable to multi-storey buildings, as their requirements are different and more complex.

D-2.1.11 It is difficult to determine precise venting requirements on account of the many variables involved. For instance, the rate of combustion varies appreciably according to the nature, shape, size and

packaging of the combustible materials as well as the size, height and disposition of the stacks of materials.

D-2.1.12 In industrial buildings of floor area less than 750 m² and used as low fire hazard occupancies, conventional ventilators fitted high up near the eaves of the external walls may serve as vents for smoke and hot gases, provided care is taken to ensure that they are kept open at all times or are designed to open automatically in case of fire.

D-2.1.13 Extinction of fires by closing the doors and windows is not likely in the case of industrial buildings because of their large size, where sufficient air to sustain the fire at least in the initial stages can be expected to be present.

D-2.1.14 Of the two types of building ventilation, namely, vertical and horizontal, vertical ventilation is the one commonly adopted in the case of single storey industrial buildings.

D-2.1.15 Since 70 to 80 percent of heat produced in a fire is convective heat, the ventilation system has to be suitably designed to ensure early outflow of the heat and thereby minimize fire spread.

D-2.1.16 Combustible roof linings shall be avoided, as they themselves will contribute to the spread of fire, thereby multiplying the venting problems.

D-2.1.17 A wind blowing across a flat roof or a roof with a pitch under 40° produces a negative pressure, that is, it tends to draw gases out of the building and so aids venting of hot gases. Wind blowing across a roof of pitch greater than 40° will draw gases out on the leeward side, but oppose outward flow on the windward side of the roof.

D-2.1.18 For vents to work at full efficiency, the area of the inlets for cold air entering the compartment must equal at least the total area of the vents. Ideally, the inlets shall be as close to the ground as possible.

D-2.1.19 Where roof vents are installed in a single-storey building any neighbouring buildings, particularly those of more than one storey, will be subject to some degree of exposure hazard either from flying birds or radiation, or both, as a result.

D-2.1.20 If vents are to be installed, the size, design, number and disposition of the vents and the associated roof screens/curtain boards have to be assessed after careful analysis of the various factors stated under **D-2.1.11** above, as well as other related factors like type of building construction, nature and height of roof, process hazards, exposure hazard, etc.

D-2.2 Venting Area

D-2.2.1 The estimated requirements for ventilation are

largely based on the assumed build-up of the fire from the time of initial outbreak to the time of effective fire fighting action by fire brigade.

D-2.2.2 The vent area required to be provided shall be approximately proportional to the perimeter of the fire area, because the entrained air forms the bulk of the vented gases.

D-2.2.3 The effective area shall be the minimum cross-sectional area through which the hot gases must flow out to the atmosphere.

D-2.2.4 No consideration shall be given to the increased air movement obtained by power operated fans, since it must be assumed that in the event of fire, power will be interrupted, or fans damaged by heat.

D-2.2.5 The total vent areas to be provided shall be as per the following ratios of effective area of vent openings to floor area for various occupancy classifications indicated:

- | | |
|--|--------------|
| a) Low heat release content
(Sub-division G-1) | 1:150 |
| b) Moderate heat release content
(Sub-division G-2) | 1:100 |
| c) High heat release content
(Sub-division G-3) | 1:30 to 1:50 |

D-2.3 Types of Vents

D-2.3.1 Venting shall be accomplished by any of the types such as monitors continuous gravity vents, until type vents or sawtooth roof skylights.

D-2.3.2 Where monitor type vents are installed, wired glass or metal panels shall be used only if the sash is arranged to open automatically.

D-2.3.3 The use of plain thin glass for venting shall be avoided on account of its unpredictable behaviour during fire. However, if glass or other suitable plastic sheet materials with early disintegration characteristics are used, they should be designed for automatic operation.

D-2.3.4 Where monitors or unit type vents are used, the panels shall be hinged at the bottom and designed to open automatically. Both sides of the vents shall be designed to vent simultaneously to ensure that their effectiveness at the time of fire is not in any way impeded by wind direction.

D-2.3.5 Where movable shutters are provided for continuous gravity vents, these shall open automatically in the event of fire.

D-2.3.6 Unit type vents shall be of relatively small area, ranging between 1 m² and 9 m², having light weight metal frames and housing with hinged dampers

which shall be designed for both manual and automatic operation.

D-2.3.7 Sawtooth roof skylight shall be considered as satisfactory for venting purposes only when designed for automatic operation.

D-2.3.8 Likewise, exterior wall windows shall not be reckoned as satisfactory means for venting of fire gases and smoke in industrial buildings. However, they may be reckoned as additional means of venting when, they are located close to the eaves and are provided with ordinary glass or movable sash arranged for both manual and automatic operation.

D-2.3.9 Baffles shall not be installed inside vents, as they greatly reduce the effective area for venting.

D-2.4 Vent Operation

D-2.4.1 The vents shall be automatic in operation, unless where specified in these provisions that they shall be designed for both manual and automatic operation.

D-2.4.2 The release mechanism shall be simple for operation and independent of electrical power, since electrical services may be interrupted by fire.

D-2.4.3 The automatic operation of vents shall be achieved by actuation of fusible links or other types of heat and smoke detectors, or by interlocking with operation of sprinkler system or any other automatic fire extinguishing system covering the area. Following their release, the vents shall be designed to open by a system of counterweights and associated equipment utilizing the force of gravity or spring loaded levers.

D-2.4.4 Automatic fire alarm system, where installed, shall be coupled to the automatic vents to ensure simultaneous operation.

D-2.4.5 Automatic sprinklers, where installed, shall operate before the vents open in order to avoid any likely delay in sprinkler operation. However, heat actuated devices used for vent release shall be suitably shielded from sprinkler discharge so that water does not delay their action.

D-2.4.6 Premises where height of roof apex is 10 m or more or where the materials handled or stored have high smoke producing characteristics, in addition to fusible links, the vent release mechanism shall be interlinked to smoke actuated automatic fire detectors to ensure early operation of vents.

D-2.4.7 Non-corrosive materials shall be used for hinges, hatches and other related parts to ensure long fail-safe operation of the vents.

D-2.4.8 In case of any doubts regarding the types of vents required to be installed for any particular

occupancy, authorities having jurisdiction shall be consulted.

D-2.5 Size, Spacing and Disposition of Vents

D-2.5.1 Vents shall be correctly sited to ensure their functional efficiency. Ideally, they shall be sited at the highest point in each area to be covered.

D-2.5.2 They shall, as far as possible, be located immediately above the risk to be protected so as to allow free and speedy removal of smoke and other combustion products in the event of fire.

D-2.5.3 The minimum dimension for an effective vent opening shall be not less than 1.25 m in any direction.

D-2.5.4 The spacing of the individual vents shall be based on the principle that more number of well distributed smaller vents are more effective than less number of badly located larger vents.

D-2.5.5 The maximum spacing between vents for the three occupancy classifications shall be as follows:

- a) *Low heat release content* — 45 m between centres
- b) *Moderate heat release content* — 36 to 37 m between centres
- c) *High heat release content* — 22.5 to 30 m between centres, depending on the severity of fire potential.

D-2.5.6 Vents shall be placed in a sheltered situation where advantage can be taken of the prevailing wind. The design of the vent shall be such as to produce a suction effect. A wind blowing across a flat roof or one with a pitch be 40° produces a negative pressure, that is, it tends to draw gases out of the building and so aids venting of hot gases. Wind blowing across a roof of pitch greater than 40° will draw gases out on the leeward side, but oppose outward flow on the windward side of the roof.

D-2.5.7 Low level inlets, with total area not less than the total area of vents, shall be provided to permit outside air to be drawn in to aid automatic venting. These inlets, which may be in the form of doors, windows or such other openings, shall be designed for manual operation when desired.

D-2.6 Roof Screens or Curtain Boards

D-2.6.1 Industrial buildings with large areas and having no sub-division/separating walls limiting the area of individual compartments to 750 m^2 or less, shall be provided with roof screens or curtain boards.

These screens which extend from the roof downwards at specific intervals not only prevent lateral spread of heat and smoke in the event of fire below, but

substantially assist in early operation of automatic sprinklers and vents.

D-2.6.2 They shall be of sheet metal or any other substantial non-combustible material strong enough to withstand damage by heat or impact.

D-2.6.3 They shall be reasonably gas-tight, although small openings for passage of pipes, conduits, etc, shall be permitted.

D-2.6.4 They shall extend down from the roof/ceiling for a minimum depth of 2.2 m. Around specific hazards, the depth shall be 4 m. Where roof/ceiling height exceeds 15 m they shall extend down to within 3 m of the floor. For pitched sawtoothed roofs, they shall extend down to truss level dividing the roof into compartments.

D-2.6.5 In moderate hazard occupancies, the distance between the screens/curtain boards shall not exceed 75 m and the curtained areas shall be limited to a maximum of $4\,500\text{ m}^2$.

D-2.6.6 In high hazard occupancies, the distance between screens shall not exceed 30 m and the curtained area shall be limited to 750 m^2 .

D-2.6.7 The curtained roof area shall be so arranged that they effectively aid in the venting of smoke and hot gases through the automatic vents provided in each area.

D-2.6.8 In sprinklered buildings, the screens shall preferably be so located as to coincide with the individual sprinkler system areas.

D-3 EXPLOSION RELIEF VENTS

D-3.1 Industrial premises where combustible dusts can accumulate or where flammable gases, vapours or mists in explosive concentrations may be present are constantly exposed to explosion hazards. Pressures developed by such explosions may be of the order of $7 \times 10^5\text{ Pa}$ and ordinary buildings will not be able to withstand the shock of such pressures. Hence, such buildings require explosion relief vents for preventing structural damage.

D-3.2 Basic Principle/Considerations

D-3.2.1 Most ordinary building walls will not withstand a sustained internal pressure as great as $6.9 \times 10^3\text{ Pa}$. Hence, explosion relief vents for buildings must be designed to operate at pressures well below those at which the building walls will fail.

D-3.2.2 There is a rise in pressure during an explosion within an enclosure even with open, unobstructed vents, and any delay in opening the venting devices increases that pressure.

D-3.2.3 Structural damage can be minimized by locating hazardous operations or equipment outside buildings and cut off from other operations by a pressure resisting wall. Such isolated processes or equipment shall be housed in single-storey buildings properly vented and a device provided at the inlet of the collector which will prevent an explosion from blowing back through the duct work and into the building.

D-3.2.4 Where highly hazardous operations cannot be located outside of main buildings they shall be segregated by pressure resisting walls and each such unit shall be ventilated outdoors. External walls may be of heavy construction if equipped with suitable vents or high weight panels which blow out easily.

D-3.2.5 Operations or equipment involving explosion hazards shall not be permitted in basements or areas partially below grade.

D-3.2.6 Fire can be expected to follow an explosion in most occupancies, so that any fixed fire extinguishing equipment, like sprinklers, if installed, shall be such that only the minimum damage is caused to it.

D-3.2.7 For a given material, the finer the particle size of the dust, the more violent is the explosion. Some materials, such as aluminium powder, hydrogen, and acetylene, are difficult to vent effectively due to the rapid rate of pressure rise. Some slow burning materials, such as coal dust in a confined space, may do much damage because of the longer duration of their presence. Some dusts, such as magnesium, titanium and zirconium and several metal hydrides may react with water and ignite in some common inert gases, such as nitrogen and carbon dioxide.

D-3.2.8 The maximum explosion pressure in a vented structure decreases as the size of the vent increases, but is independent of the rupturing pressure of a diaphragm.

D-3.2.9 The most effective vent for the release of explosion pressures is an unobstructed vent opening.

D-3.2.10 Pressure required to rupture diaphragms of the same area and material directly varies with the thickness of the material.

D-3.2.11 The slower the rate of pressure rise, the more easily can the explosion be vented.

D-3.2.12 The degree of venting required is directly proportional to the degree of explosion hazard.

D-3.2.13 Experience has shown that most explosions of dusts, vapours and gases do not involve a large part of the total volume of the enclosure, and frequently occur near the upper or lower limits of the explosive range. Consequently, such explosions are relatively weak compared with the optimum.

D-3.2.14 Rectangular unrestricted vents are as effective as square vents of equal area.

D-3.3 Types of Explosion Relief Vents

D-3.3.1 The explosion relief vents shall be any one or more of the following types, depending on individual requirements as assessed by the Authority. Open or unobstructed vents, louvers, open roof vents, hanger type doors, building doors, windows, roof or wall panels or movable fixed sash.

D-3.3.2 The effect of external wind pressure or suction on these devices shall be taken into consideration while designing and selecting the type of vents, since wind pressures may reach over 2×10^5 Pa in severe wind storms.

D-3.3.3 The type of vent for explosion relief for any occupancy shall be selected with life safety as the primary aim followed by minimum damage to property.

D-3.3.4 Where large hanger type doors or metal curtain doors in side walls are used as vents care shall be taken to ensure that they are kept wide open during operations.

D-3.3.5 Where weather hoods are used to cover roof vents, they shall be as light as possible and lightly attached so as to enable them to be blown off quickly when an explosion occurs.

D-3.3.6 Doors and windows when used as explosion vents shall be installed to swing outwards. Doors shall have friction, spring or magnetic latches that will function automatically to permit the door to open under slight internal pressure.

D-3.3.7 Movable sash shall be of the top or bottom hinged or protected type. These shall be equipped with a latch or friction device to prevent accidental opening due to wind action or intrusion. Such latches or locks shall be well maintained.

D-3.3.8 Fixed sash shall be set in place with very light wall anchorages, or, if right, shall be securely fitted and glazed with plastic panes in plastic putty.

D-3.3.9 Where the process is such that the whole of a building or a room may be desirable to arrange for a lightly constructed wall or roof to collapse and thus avert the worst effects of an explosion.

D-3.4 Design, Size and Disposition of Vents

D-3.4.1 The required area of explosion vents shall ordinarily depend on the expected maximum intensity of an explosion in the occupancy, the strength of the structure, the type of vent closure and other factors.

D-3.4.2 Venting shall be planned in such a manner as

to prevent injury to personnel and damage to exposures. In congested locations, substantial ducts or diverters shall be provided to direct the blast.

D-3.4.3 When ductwork is used, the ducts shall be of sufficient strength to withstand the maximum expected explosion pressure.

D-3.4.4 Where explosions are likely within duct and piping systems, they shall be vented by the use of suitable diaphragms designed to blow out at a predetermined pressure. There shall be no physical connection between ductwork system for more than one collector.

D-3.4.5 In large structures, the position of vents shall be relative to the point of origin of explosion, when it can be determined.

D-3.4.6 Where relatively slow explosions involving coal dust, chlorinated solvents, etc, are involved, light, hinged swinging panels may be preferred to diaphragm type of vents.

D-3.4.7 Obstructions of any kind blocking the vents from the risk covered shall be avoided, particularly where risks of rapid violent explosions are present.

D-3.4.8 Counter weights add to the inertia of the vents and so shall be avoided.

D-3.4.9 Various relieving devices, including devices actuated by detonators, shall start to open at as low a pressure as possible. They shall be of light construction, so that full opening can be quickly attained.

D-3.4.10 Vents shall be of such size and design as to prevent rupture of the protected device or apparatus.

D-3.4.11 Skylights or monitors with movable sash that will open outwards, or fixed sash containing panes of glass or plastic that will blow out readily under pressure from within, can be used to supplement wall vents or windows, provided resistance to their displacement or opening is kept as low as consistent with the requirements for structural strength.

D-3.4.12 Flexible plastic sheets when used for vent closures shall be installed in slotted frames in such a way that pressure from within bulges the sheets and releases them from the holding frame.

D-3.4.13 Fragile sheets made of plastic, when used for vent closures, shall be thin sheets that will crack or rupture under less pressure than single strength glass. For this reason use of transparent or translucent plastic sheets is more advantageous instead of glass in window sash.

D-3.4.14 If closed vents are used they shall be larger in area than unenclosed vents to provide equivalent explosion pressure relief.

D-3.4.15 Small enclosures, such as machines, shall be vented more generously than buildings, because if an explosion occurs in a machine, its entire volume may be involved.

D-3.4.16 Vents for the protection of buildings and equipment shall be installed on the following basis:

D-3.4.16.1 Small enclosures of less than 30 m³, machines and ovens of light construction: 1 000 cm² for each 0.3 m³ to 0.9 m³.

D-3.4.16.2 For small enclosures of more substantial construction having reasonably high bursting strength: 1 000 cm² for each 0.9 m³.

D-3.4.16.3 Fairly large enclosures of 30 to 700 m³, such as bins, silos, rooms, storage tanks, etc: 1 000 cm² for each 0.9 m³ to 1.5 m³. In these cases, attempt shall be made to the extent possible to predict the likely point of origin of the explosion in relation to the vent.

D-3.4.16.4 Large rooms and buildings over 700 m³ containing hazardous equipment comprising a small fraction of the entire volume:

- a) *For heavy reinforced concrete, walls* — 100 cm² for each 2.25 m³.
- b) *For light reinforced concrete, brick or wood construction* — 1 000 cm² for each 1.65 m³ to 2.25 m³.
- c) *For lightweight construction such as prefabricated panels* — 1 000 cm² for each 1.5 m³ to 1.65 m³.

D-3.4.16.5 Large rooms or building over 700 m³ containing hazardous equipment comprising a large part of the entire volume of a room or building shall be vented as generously as possible 1 000 cm² for each 0.3 m³ to 1.05 m³.

D-3.4.16.6 In order to obtain these ratios, the size of the building or room must be limited. For some hazardous materials, such as hydrogen, acetylene, carbon disulphide, etc, these limits are extremely low.

D-3.4.17 Emphasis shall always be placed on segregating hazardous areas by means of firewalls or separating walls to prevent spread of fire.

D-3.4.18 Interior walls of light construction, such as tile, shall be avoided in hazardous locations, since they can cause injuries to personnel in the event of an explosion.

ANNEX E

(Clause C-8)

GUIDELINES FOR FIRE DRILL AND EVACUATION PROCEDURES FOR HIGH RISE BUILDINGS (ABOVE 15 m IN HEIGHT)

E-1 INTRODUCTION

In case of fire in a high rise building, safe evacuation of its occupants may present serious problems unless a plan for orderly and systematic evacuation is prepared in advance and all occupants are well drilled in the operation of such plan. These guidelines are intended to assist them in this task.

E-2 ALARMS

Any person discovering fire, heat or smoke shall immediately report such condition to the fire brigade, unless he has personal knowledge that such a report has been made. No person shall make, issue, post or maintain any regulation or order, written or verbal, that would require any person to take any unnecessary delaying action prior to reporting such condition to the fire brigade.

E-3 DRILLS

E-3.1 Fire drills shall be conducted, in accordance with the Fire Safety Plan, at least once every three months for existing buildings during the first two years. Thereafter, fire drills shall be conducted at least once every six months.

E-3.2 All occupants of the building shall participate in the fire drill. However, occupants of the building, other than building service employees, are not required to leave the floor or use the exits during the drill.

E-3.3 A written record of such drills shall be kept on the premises for a three years period and shall be readily available for fire brigade inspection.

E-4 SIGNS AND PLANS

E-4.1 Signs at Lift Landings

A sign shall be posted and maintained in a conspicuous place on every floor at or near the lift landing in accordance with the requirements, indicating that in case of fire, occupants shall use the stairs unless instructed otherwise. The sign shall contain a diagram showing the location of the stairways except that such diagram may be omitted, provided signs containing such diagram are posted in conspicuous places on the respective floor.

A sign shall read "IN CASE OF FIRE, USE STAIRS UNLESS INSTRUCTED OTHERWISE". The lettering shall be at least 12.5 mm block letters in red and white

background. Such lettering shall be properly spaced to provide good legibility. The sign shall be at least 250 mm × 300 mm, where the diagram is also incorporated in it and 62.5 mm × 250 mm where the diagram is omitted. In the latter case, the diagram sign shall be at least 200 mm × 300 mm. The sign shall be located directly above a call-button and squarely attached to the wall or partition. The top of the sign shall not be above 2 m from the floor level.

E-4.2 Floor Numbering Signs

A sign shall be posted and maintained within each stair enclosure on every floor, indicating the number of the floor, in accordance with the requirements given below.

The numerals shall be of bold type and at least 75 mm high. The numerals and background shall be in contrasting colours. The sign shall be securely attached to the stair side of the door.

E-4.3 Stair and Elevator Identification Signs

Each stairway and each elevator back shall be identified by an alphabetical letter. A sign indicating the letter of identification shall be posted and maintained at each elevator landing and on the side of the stairway door from which egress is to be made, in accordance with the requirements given below:

The lettering on the sign shall be at least 75 mm high, of bold type and of contrasting colour from the background. Such signs shall be securely attached.

E-4.4 Stair Re-entry Signs

A sign shall be posted and maintained on each floor within each stairway and on the occupancy side of the stairway where required, indicating whether re-entry is provided into the building and the floor where such re-entry is provided, in accordance with the requirements given below:

The lettering and numerals of the signs shall be at least 12.5 mm high of bold type. The lettering and background shall be of contrasting colours and the signs shall be securely attached approximately 1.5 m above the floor level.

E-4.5 Fire command station shall be provided with floor plan of the building and other pertinent information relative to the service equipment of the building.

E-5 FIRE SAFETY PLAN

E-5.1 A format for the Fire Safety Plan shall be as given in **E-8**.

E-5.2 The applicable parts of the approved Fire Safety Plan shall be distributed to all tenants of the building by the building management when the Fire Safety Plan has been approved by the Fire Authority.

E-5.3 The applicable parts of the approved Fire Safety Plan shall then be distributed by the tenants to all their employees and by the building management to all their building employees.

E-5.4 Where the owner of the building is also an occupant of the building, he shall be responsible for the observance of these rules and the Fire Safety Plan in the same manner as a tenant.

E-5.5 In the event there are changes from conditions existing at the time the Fire Safety Plan for the building was approved, and the changes are such so as to require amending the Fire Safety Plan, within 30 days after such changes, an amended Fire Safety Plan shall be submitted to the fire brigade for approval.

E-6 FIRE COMMAND STATION

A Fire Command Station shall be established in the lobby of the building on the entrance floor. Such command station shall be adequately illuminated.

E-7 COMMUNICATIONS AND FIRE ALARM

A means of communication and fire alarm for use during fire emergencies shall be provided and maintained by the owner or person in charge of the building.

E-8 FIRE SAFETY PLAN FORMAT

E-8.1 Building Address

Street and Pin Code Number

Telephone Number

E-8.2 Purpose and Objective

E-8.2.1 Purpose

To establish method of systematic, safe and orderly evacuation of an area or building by its occupants in case of fire or other emergency, in the least possible time, to a safe area by the nearest safe means of egress; also the use of such available fire appliances (including sounding of alarms) as may have been provided for controlling or extinguishing fire and safeguarding of human life.

E-8.2.2 Objective

To provide proper education as a part of continuing employee indoctrination and through a continuing

written programme for all occupants, to ensure prompt reporting of fire, the response of fire alarms as designated, and the immediate initiation of fire safety procedures to safeguard life and contain fire until the arrival of the fire brigade.

E-8.3 Fire Safety Director

- a) Name
- b) Regularly assigned employment — Title
- c) Regularly assigned location
- d) How is he notified when at regular location?
- e) How is he notified when not at regular location?
- f) Normal working hours
- g) Duties of Fire Safety Director (*see E-9.1*)

E-8.4 Deputy Fire Safety Director

- a) Name
- b) Regularly assigned employment — Title
- c) Regularly assigned location
- d) How is he notified when at regular location?
- e) How is he notified when not at regular location?
- f) Normal working hours
- g) Duties of Deputy Fire Safety Director (*see E-9.2*)

E-8.5 Fire Wardens and Deputy Fire Wardens

- a) Are their names on Organization Charts for each floor and/or tenancy?
- b) Submit typical completed Organization Chart for Fire Drill and Evacuation Assignment.
- c) Duties of Fire Wardens and Deputy Fire Wardens (*see E-9.3*).

E-8.6 Building Evacuation Supervisor

- a) Name
- b) Regularly assigned employment — Title
- c) Regularly assigned location
- d) How is he notified when at regular location?
- e) How is he notified when not at regular location?
- f) Normal working hours
- g) Duties of Building Evacuation Supervisor (*see E-9.4*).

E-8.7 Fire Party

- a) Submit a completed Organization Chart for Fire Parties naming person in charge, and his title in the building.
- b) Indicate standards of selection from building employees based on background and availability.

- c) How are they notified?
- d) How are they notified when they are not at their regular locations?
- e) Means of responding
- f) Duties of each member of Fire Party (*see E-9.5*).

E-8.8 Occupants Instructions

Distribution of instructions to all tenants, tenants' employees and building employees (*see E-9.6*).

E-8.9 Evacuation Drills

- a) Frequency of drills
- b) How conducted?
- c) Participation: Who participated? How?
- d) Controls and supervision
- e) Recording of details of drills

E-8.10 Fire Command Station

- a) Location
- b) Requirements
 - 1) Adequate illumination
 - 2) Adequate communication to mechanical equipment room and elevator control room on each floor
 - 3) Copy of Fire Safety Plan
 - 4) Copy of Building Information Form
 - 5) Representative floor plans showing location of signs, floor remote station, communications, etc.

E-8.11 Signs

- a) Signs at elevator landings, Floor diagrams
- b) Floor numbering
- c) Stairway identification
- d) Elevator identification
- e) Stair re-entry

E-8.12 Fire Prevention and Fire Protection Programme (*see E- 9.7*).

E-8.13 Building Information Form (*see E-9.8*).

E-8.14 Representative Floor Plan (*see E-9.9*).

E-8.15 Fire Safety Plan Prepared by (*see E-9.10*).

- a) Date when prepared.
- b) Date when revised.

E-9 DUTIES

E-9.1 Fire Safety Director's Duties

E-9.1.1 Be familiar with the written Fire Safety Plan providing for fire drill and evacuation procedure in accordance with orders on the subject.

E-9.1.2 Select qualified building service employees for a Fire Party and organize, train and supervise such Fire Brigade.

E-9.1.3 Be responsible for the availability and state of readiness of the Fire Party.

E-9.1.4 Conduct fire and evacuation drills.

E-9.1.5 Be responsible for the designation and training of a Fire Warden for each floor, and sufficient Deputy Fire Wardens for each tenancy in accordance with orders on the subject.

E-9.1.6 Be responsible for a daily check for the availability of the Fire Wardens, and see that up-to-date organization charts are posted.

NOTE — If the number of Fire Wardens and Deputy Fire Wardens in the building is such that it is impractical to individually contact each one daily, a suggested method to satisfy the requirements is to make provisions for the Fire Warden, or a Deputy Fire Warden in the absence of the Fire Warden, to notify the Fire Safety Director when the Fire Warden or required number of Deputy Fire Wardens are not available. In order to determine the compliance by the Fire Warden and Deputy Fire Wardens, when this method is used, the Fire Safety Director shall make a spot check of several different floors each day.

E-9.1.7 Notify the owner or some other person having charge of the building when any designated individual is neglecting his responsibilities contained in Fire Safety Plan. The owner or the other person in-charge of the building shall bring the matter to the attention of the firm employing the individual. If the firm fails to correct the condition, the Fire Department shall be notified by the owner/person in-charge of the building.

E-9.1.8 In the event of fire, shall report to the Fire Command Station to supervise, provide for and coordinate:

- a) Ensure that the Fire Department has been notified of any fire or fire alarm.
- b) Manning of the Fire Command Station.
- c) Direction of evacuating procedures as provided in the Fire Safety Plan.
- d) Reports on conditions on fire floor for information of Fire Department on their arrival.
- e) Advise the Fire Department Officer in-charge in the operation of the Fire Command Station.

E-9.1.9 Be responsible for the training and activities of the Building Evacuation Supervisor.

E-9.2 Deputy Fire Safety Director's Duties

E-9.2.1 Subordinate to the Fire Safety Director.

E-9.2.2 Perform duties of Fire Safety Director in his absence.

E-9.3 Fire Wardens and Deputy Fire Wardens Duties

The tenant or tenants of each floor shall, upon request of the owner or person in charge of buildings, make responsible and dependable employees available for designation by the Fire Safety Director as Fire Warden and Deputy Fire Wardens.

E-9.3.1 Each floor of a building shall be under the direction of a designated Fire Warden for the evacuation of occupants in the event of fire. He shall be assisted in his duties by the Deputy Fire Wardens. A Deputy Fire warden shall be provided for each tenancy. When the floor area of a tenancy exceeds 700 m² of occupiable space, a Deputy Fire Warden shall be assigned for each 700 m² or part thereof.

E-9.3.2 Each Fire Warden and Deputy Fire Warden shall be familiar with the Fire Safety Plan, the location of exits and the location and operation of any available fire alarm system.

E-9.3.3 In the event of fire, or fire alarm the Fire Warden shall ascertain the location of the fire, and direct evacuation of the floor in accordance with directions received and the following guidelines:

- a) The most critical areas for immediate evacuation are the fire floor and floors immediately above.
Evacuation from the other floors shall be instituted when instructions from the Fire Command Station or conditions indicate such action. Evacuation shall be via uncontaminated stairs. The Fire Warden shall try to avoid stairs being used by the Fire Department. If this is not possible, he shall try to attract the attention of the Fire Department Personnel before such personnel open the door to the fire floor.
- b) Evacuation to two or more levels below the fire floor is generally adequate. He shall keep the Fire Command Station informed regarding his location.
- c) Fire Wardens and their Deputies shall see that all occupants are notified of the fire, and that they proceed immediately to execute the Fire Safety Plan.
- d) The Fire Warden on the fire floor shall, as soon as practicable, notify the Fire Command Station of the particulars.
- e) Fire Wardens on floors above the fire shall, after executing the Fire Safety Plan, notify the Fire Command Station of the means being used for evacuation and any other particulars.
- f) In the event that stairways serving fire floor

and/or floors above are unusable due to contamination or cut off by fire and/or smoke or that several floors above fire involve large numbers of occupants who must be evacuated, consideration may be given to using elevators in accordance with the following:

- 1) If the elevators servicing his floor also service the fire floor, they shall not be used. However, elevators may be used if there is more than one bank of elevators, and he is informed from the Fire Command Station that one bank is unaffected by the fire.
 - 2) If elevators do not service the fire floor and their shafts have no openings on the fire floor, they may be used, unless directed otherwise.
 - 3) Elevators manned by trained building personnel or firemen may also be used.
 - 4) In the absence of a serviceable elevator, the Fire Warden shall select the safest stairway to use for evacuation on the basis of the location of the fire and any information received from the Fire Command Station. The Fire Warden shall check the environment in the stairs prior to entry for evacuation. If it is affected by smoke, alternative stair shall be selected, and the Fire Command Station notified.
 - 5) The Fire Warden shall keep the Fire Command Station informed of the means being employed for evacuation by the occupants of his floor.
- g) Ensure that an alarm has been transmitted.

E-9.3.4 Organization Chart for Fire Drill and Evacuation Assignment

A chart designating employees and their assignments shall be prepared and posted in a conspicuous place in each tenancy and on each floor of a tenancy that occupies more than one floor and a copy shall be in the possession of the Fire Safety Director.

E-9.3.5 Keep available an updated listing of all personnel with physical disabilities who cannot use stairs unaided. Make arrangements to have these occupants assisted in moving down the stairs to two or more levels below fire floor. If it is necessary to move such occupants to a still lower level during the fire, move them down the stairs to the uppermost floor served by an uninvolved elevator bank and then remove them the street floor by elevator. Where assistance is required for such evacuation, notify Fire Safety Director.

E-9.3.6 Provide for Fire Warden identification during fire drills and fires, such as using armband, etc.

E-9.3.7 Ensure that all persons on the floor are notified of fire and all are evacuated to safe areas. A search must be conducted in the lavatories to ensure all are out. Personnel assigned as searchers can promptly and efficiently perform this duty.

E-9.3.8 Check availability of applicable personnel on Organization Chart and provide for a substitute when the position on a chart is not covered.

E-9.3.9 After evacuation, perform a head count to ensure that all regular occupants known to have occupied the floor have been evacuated.

E-9.3.10 When alarm is received, the Fire Warden shall remain at a selected position in the vicinity of the communication station on the floor, in order to maintain communication with the Fire Command Station and to receive and give instructions.

E-9.4 Building Evacuation Supervisor's Duties

A building Evacuation Supervisor is required at all times other than normal working or business hours when there are occupants in the building and there is no Fire Safety Director on duty in the building.

E-9.4.1 He should be capable of directing the evacuation of the occupants as provided by the Fire Safety Plan.

E-9.4.2 During fire emergencies, the primary responsibility of the Building Evacuation Supervisor shall be to man the Fire Command Station, and the direction and execution of the evacuation as provided in the Fire Safety Plan. The Building Evacuation Supervisor's training and related activities shall be under the direction of the Fire Safety Director in accordance with these rules, and the Fire Safety Plan. Such activities shall be subject to Fire Department control.

E-9.5 Fire Party Duties

On receipt of an alarm for fire the Fire Party shall:

- a) report to the floor below the fire to assist in evacuation and provide information to the Fire Command Station.
- b) after evacuations of fire floor, endeavour to control spread of fire by closing doors, etc.
- c) attempt to control the fire until arrival of the Fire Department, if the fire is small and conditions do not pose a personal threat.
- d) leave one member on the floor below the fire to direct the Fire Department to the fire location and to inform them of conditions.

- e) on arrival of the Fire Department, the Fire Party shall report to the Fire Command Station for additional instructions.
- f) have a member designated as runner, who shall know the location of the nearest telephone, and be instructed in its use. Such member shall immediately upon receipt of information that there is a fire or evidence of fire, go to the telephone, transmit an alarm and await the arrival of the Fire Department and direct such department to the fire.

NOTE — A chart designating employees and their assignments shall be prepared.

E-9.6 Occupant's Instructions

- a) The applicable parts of the approved Fire Safety Plan shall be distributed to all tenants of the building by the building management when the Fire Safety Plan has been approved by the Fire Commissioner.
- b) The applicable parts of the approved Fire Safety Plan shall then be distributed by the tenants to all their employees and by the building management to all their building employees.
- c) All occupants of the building shall participate and cooperate in carrying out the provisions of the Fire Safety Plan.

E-9.7 Fire Prevention and Fire Protection Programme

- a) A plan for periodic formal inspections of each floor area, including exit facilities, fire extinguishers and house keeping shall be developed. A copy of such plan be submitted.
- b) Provision shall be made for the monthly testing of communication and alarm systems.

E-9.8 Building Information Form

It shall include the following information:

- a) Building address.....Pin Code.....
- b) Owner or person in-charge of building — Name, Address and Telephone Number.
- c) Fire Safety Director and Deputy Fire Safety Director's Name and Telephone Number.
- d) Certificate of occupancy. Location where posted, or duplicate attached.
- e) Height, area, class of construction.
- f) Number, type and location of fire stairs and/or fire towers.
- g) Number, type and location of horizontal exits or other areas of refuge.
- h) Number, type, location and operation of elevators and escalators.

- j) Interior fire alarms, or alarms to central stations.
- k) Communications systems and/or walkie talkie, telephones, etc.
- m) Standpipe system; size and location of risers, gravity or pressure tank, fire pump, location of siamese connections, name of employee with certificate of qualification and number of certificate.
- n) Sprinkler system; name of employee with Certificate of Fitness and certificate number. Primary and secondary water supply, fire pump and areas protected.
- p) Special extinguishing system, if any, components and operation.
- q) Average number of persons normally employed in building. Daytime and night time.
- r) Average number of handicapped people in building. Location. Daytime and night time.
- s) Number of persons normally visiting the building. Daytime and night time.
- t) Service equipment such as:
 - 1) Electric power, primary, auxiliary;
 - 2) Lighting, normal, emergency, type and location;
 - 3) Heating, type, fuel, location of heating unit;
 - 4) Ventilation — with fixed windows, emergency means of exhausting heat and smoke;
 - 5) Air-Conditioning Systems — Brief description of the system, including ducts and floors serviced;
 - 6) Refuse storage and disposal;
 - 7) Fire fighting equipment and appliances, other than standpipe and sprinkler system; and
 - 8) Other pertinent building equipment.
- u) Alterations and repair operations, if any, and the protective and preventive measures necessary to safeguard such operations with attention to torch operations.
- v) Storage and use of flammable solids, liquids and/or gases.
- w) Special occupancies in the building and the proper protection and maintenance thereof. Places of public assembly, studios, and theatrical occupancies.

E-9.9 Representative Floor Plan

A floor plan, representative of the majority or the floor designs of the entire building, shall be at the Command Post, in the main lobby, under the authority of the Fire

Safety Director. One copy of a representative floor plan shall be submitted to the Fire Department with the Fire Safety plan.

E-9.10 Fire Safety Plan

In planning, evaluate the individual floor layouts, the population of floors, the number and kinds of exits, the zoning of the floor by area and occupants. Determine the movement of traffic by the most expeditious route to an appropriate exit and alternative route for each zone, since under fire conditions one or more exits may not be usable. This format is to be used in the preparation of the Fire Safety Plan. Nothing contained in this Fire Safety Plan format is to be construed as all inclusive. All rules and other requirements are to be fully complied with.

E-9.11 Personal Fire Instruction Card

All the occupants of the building shall be given a Personal Fire Instruction Card giving the details of the floor plan and exit routes along with the instruction to be followed in the event of fire. A typical Personal Fire Instruction Card shall be as follows:

PERSONAL FIRE
INSTRUCTION CARD
SEAL

NAME OF THE ORGANIZATION
ADDRESS OF THE ORGANIZATION

NAME:

DESIGNATION:

FLOOR NO.:

DATE:

FIRE WARDEN

INSTRUCTIONS

FOR YOUR OWN SAFETY YOU SHOULD KNOW

1. Two push button fire alarm boxes are provided per floor. You should read the operating instructions.
2. You should read the operating instructions on the body of the fire extinguishers provided on your floor.
3. The nearest exit from your table.
4. Your assembly point on ground floor (check with your Fire/Deputy Fire Warden).
5. FOR YOUR OWN PROTECTION YOU SHOULD REPORT TO YOUR FIRE/ DEPUTY FIRE WARDEN

- a) If any exit door/route is obstructed by loose materials, goods, boxes, etc.
- b) If any staircase door, lift lobby door does not close automatically, or does not close completely.
- c) If any push button fire alarm point, or fire extinguisher is obstructed, damaged or apparently out of order.

IF YOU DISCOVER A FIRE

1. Break the glass of the nearest push button fire alarm and push the button.
2. Attack the fire with extinguishers provided on your floor. Take guidance from your Wardens.

3. Evacuate if your Warden asks you to do so.

IF YOU HEAR EVACUATION INSTRUCTIONS

1. Leave the floor immediately by the south/north staircase.
2. Report to your Warden, at your predetermined assembly point outside the building.
3. Do not try to use lifts.
4. Do not go to cloakroom.
5. Do not run or shout.
6. Do not stop to collect personal belongings.
7. Keep the lift lobby and staircase doors shut.

YOUR ASSEMBLY POINT IS

LIST OF STANDARDS

The following list records those standards which are acceptable as ‘good practice’ and ‘accepted standards’ in the fulfillment of the requirements of the Code. The standards listed may be used by the Authority as a guide in conformance with the requirements of the referred clauses in the Code.

<i>IS No.</i>	<i>Title</i>	<i>IS No.</i>	<i>Title</i>
(1) 3808 : 1979	Method of test for non-combustibility of building materials (<i>first revision</i>)	3844 : 1989	Code of practice for installation and maintenance of internal fire hydrants and hose reels on premises (<i>first revision</i>)
(2) 8757 : 1999	Glossary of terms associated with fire safety (<i>first revision</i>)	(7) 3614 (Part 1) : 1966	Specification for fire check doors: Part 1 Plate, metal covered and rolling type
7673 : 1975	Glossary of terms for fire fighting equipment	(8) 12458 : 1988	Method of test for fire resistance test for fire stops
(3) 15394 : 2003	Fire safety in petroleum refinery and fertilizer plants — Code of practice	(9) 1646 : 1997	Code of practice for fire safety of buildings (general) : Electrical installations (<i>second revision</i>)
(4) 8758 : 1993	Recommendations for fire precautionary measures in the construction of temporary structures and <i>PANDALS</i> (<i>first revision</i>)	2309 : 1989	Code of practice for protection of building and allied structures against lightning (<i>second revision</i>)
(5) 3809 : 1979	Fire resistance test of structure (<i>first revision</i>)	(10)	Specification for fire dampers for air conditioning ducts (<i>under preparation</i>)
1641 : 1988	Code of practice for fire safety of buildings (general): General principles of fire grading and classification (<i>first revision</i>)	(11) 11360 : 1985	Specification for smoke detectors for use in automatic electrical fire alarm system
15103 : 2002	Specification for fire resistant steel	(12) 659 : 1964	Safety code for air-conditioning
(6) 9668 : 1990	Code of practice for provision and maintenance of water supplies and fire fighting	(13) 1649 : 1962	Code of practice for design and construction of flues and chimneys for domestic heating appliances (<i>first revision</i>)
		1642 : 1989	Code of practice for safety of buildings (general): Details of construction (<i>first revision</i>)
		(14) 12777 : 1989	Fire safety-flame-spread of products — Method for classification

<i>IS No.</i>	<i>Title</i>	<i>IS No.</i>	<i>Title</i>
(15) 1642 : 1989	Code of practice for fire safety of buildings (general): Details of construction (<i>first revision</i>)	906 : 1988	Specification for revolving branch pipe for fire fighting (<i>third revision</i>)
1643 : 1988	Code of practice for fire safety of buildings (general): Exposure hazard (<i>first revision</i>)	907 : 1984	Specification for suction strainers, cylindrical type for fire fighting purpose (<i>second revision</i>)
1644 : 1988	Code of practice for fire safety of buildings (general): Exit requirements and personal hazard (<i>first revision</i>)	908 : 1975	Specification for fire hydrant, stand post type (<i>second revision</i>)
(16) 9457 : 1980	Safety colours and safety signs	909 : 1992	Specification for underground fire hydrant: Sluice valve type (<i>third revision</i>)
12349 : 1988	Fire protection — Safety sign	910 : 1980	Specification for combined key for hydrant, hydrant cover and lower valve (<i>second revision</i>)
12407 : 1988	Graphic symbols for fire protection plan	926 : 1985	Specification for fireman's axe (<i>second revision</i>)
(17) 2175 : 1988	Specification for heat sensitive fire detectors for use in automatic fire alarm system (<i>second revision</i>)	927 : 1981	Specification for fire hooks (<i>second revision</i>)
11360 : 1985	Specification for smoke detectors for use in automatic electrical fire alarm system	928 : 1984	Specification for fire bells (<i>second revision</i>)
(18) 2189 : 1999	Code of practice for selection, installation and maintenance of automatic fire detection and alarm system (<i>second revision</i>)	937 : 1981	Specification for washers for water fittings for fire fighting purposes (<i>second revision</i>)
(19) 636 : 1988	Non-percolating flexible fire fighting delivery hose (<i>third revision</i>)	939 : 1977	Specification for snatch block for use with fibre rope for fire brigade use (<i>first revision</i>)
884 : 1985	Specification for first-aid hose reel for fire fighting (<i>first revision</i>)	940 : 1989	Specification for portable fire extinguisher, water type (gas cartridge) (<i>third revision</i>)
901 : 1988	Specification for couplings, double male and double female instantaneous pattern for fire fighting (<i>third revision</i>)	941 : 1985	Specification for blowers and exhauster for fire fighting (<i>second revision</i>)
902 : 1992	Specification for suction hose couplings for fire fighting purposes (<i>third revision</i>)	942 : 1982	Functional requirements for 275-l/min portable pump set for fire fighting (<i>second revision</i>)
903 : 1993	Specification for fire hose delivery couplings, branch pipe, nozzles and nozzle spanner (<i>fourth revision</i>)	943 : 1979	Functional requirement for 680-l/min trailer pump for fire brigade use (<i>second revision</i>)
904 : 1983	Specification for two-way and three-way suction collecting heads for fire fighting purposes (<i>second revision</i>)	944 : 1979	Functional requirement for 1800-l/min trailer pump for fire brigade use (<i>second revision</i>)
905 : 1980	Specification for delivery breechings, dividing and collecting, instantaneous pattern for fire fighting purposes (<i>second revision</i>)	947 : 1985	Functional requirement for towing tender for trailer fire pump for fire brigade use (<i>first revision</i>)
		948 : 1983	Functional requirement for water tender, Type A, for fire brigade use (<i>second revision</i>)
		949 : 1985	Functional requirement for emergency (rescue) tender for fire brigade use (<i>second revision</i>)

<i>IS No.</i>	<i>Title</i>	<i>IS No.</i>	<i>Title</i>
950 : 1980	Functional requirements for water tender, Type B for fire brigade use (<i>second revision</i>)	4308 : 1982	Specification for dry powder for fire fighting (<i>first revision</i>)
952 : 1986	Specification for foghnozzle for fire brigade use (<i>first revision</i>)	4571 : 1977	Specification for aluminium extension ladders for fire brigade use (<i>first revision</i>)
955 : 1980	Functional requirements for dry power tender for fire-brigade use (150 kg capacity) (<i>first revision</i>)	4643 : 1984	Specification for suction wrenches for fire brigade use (<i>first revision</i>)
957 : 1967	Specification for control van for fire brigade	4861 : 1984	Specification for dry powder for fighting fires in burning metals (<i>first revision</i>)
1941 (Part 1) : 1976	Functional requirements for electric motor sirens: Part 1 ac 3 phase 50Hz, 415 V type (<i>second revision</i>)	4927 : 1992	Specification for unlined flax canvas hose for fire fighting (<i>first revision</i>)
2097 : 1983	Specification for foam making branch pipe (<i>first revision</i>)	4928 : 1986	Specification for delivery valve for centrifugal pump outlets (<i>first revision</i>)
2171 : 1999	Specification for portable fire extinguishers, dry powder (cartridge type) (<i>third revision</i>)	4947 : 1985	Specification for gas cartridges for use in fire extinguishers (<i>second revision</i>)
2175 : 1988	Specification for heat sensitive fire detectors for use in automatic detectors for use in automatic fire alarm system (<i>second revision</i>)	4989 (Part 1) : 2004	Specifications for multipurpose aqueous film forming foam liquid concentrate for extinguishing hydrocarbon and polar solvent fires (<i>third revision</i>)
2298 : 1977	Specification for single-barrel stirrup pump for fire fighting purposes (<i>second revision</i>)	4989 (Part 2) : 1984	Specification for foam concentrate (compound) for producing mechanical foam for fire fighting: Part 2 Aqueous film forming foam (AFFF)
2546 : 1974	Specification for galvanized mild steel fire bucket (<i>first revision</i>)	(Part 3) : 1987	Fluoro protein foam
2696 : 1974	Functional requirements for 1 125 l/min light fire engine (<i>first revision</i>)	5131 : 1986	Specification for dividing breaching with control, for fire brigade use (<i>first revision</i>)
2745 : 1983	Specification for non-metal helmet for firemen and civil defence personnel (<i>second revision</i>)	5290 : 1993	Specification for landing valve (<i>third revision</i>)
2871 : 1983	Specification for branch pipe, universal for fire fighting purposes (<i>first revision</i>)	5486 : 1985	Specification for quick release knife (<i>first revision</i>)
2878 : 2004	Specification for fire extinguisher, carbon-dioxide type (portable and trolley mounted) (<i>third revision</i>)	5505 : 1985	Specification for multi-edged rescue axe (non-wedging) (<i>first revision</i>)
2930 : 1980	Functional requirements for hose laying tender for fire brigade use (<i>first revision</i>)	5612 (Part 1) : 1977	Specification for hose-clamps and hose-bandages for fire brigade use: Hose clamps (<i>first revision</i>)
3582 : 1984	Specification for basket strainers for fire fighting purposes (cylindrical type) (<i>first revision</i>)	(Part 2) : 1977	Hose bandages (<i>first revision</i>)
		5714 : 1981	Specification for hydrant, stand-pipe for fire fighting (<i>first revision</i>)

<i>IS No.</i>	<i>Title</i>	<i>IS No.</i>	<i>Title</i>
6026 : 1985	Specification for hand-operated sirens (<i>first revision</i>)	12717 : 1989	Functional requirements of fire fighting equipment — High capacity portable pumpset (1 100-1 600 l/min)
6067 : 1983	Functional requirements for water tender, Type 'X' for fire brigade use (<i>first revision</i>)	12796 : 1989	Specification for fire rake
6234 : 1986	Specification for portable fire extinguishers, water type (stored pressure) (<i>first revision</i>)	13039 : 1991	Code of practice for provision and maintenance of external hydrant system
8090 : 1992	Specification for couplings, branch pipe, nozzle, used in hose reel tubing for fire fighting (<i>first revision</i>)	13385 : 1992	Specification for fire extinguisher 50 capacity wheel mounted water type (gas cartridge)
8096 : 1992	Specification for fire beaters (<i>first revision</i>)	13386 : 1992	Specification for 50 litre capacity fire extinguisher, mechanical foam type
8149 : 1994	Functional requirements for twin CO ₂ fire extinguishers (trolley mounted) (<i>first revision</i>)	13849 : 1993	Specification for portable fire extinguisher dry powder type (constant pressure)
8423 : 1994	Specification for controlled percolating hose for fire fighting (<i>first revision</i>)	14609 : 1999	Specification for ABC dry powder for fire fighting
8442 : 1977	Specification for stand post type water monitor for fire fighting	14933 : 2001	Specification for high pressure fire fighting hose
9972 : 1981	Specification for automatic sprinkler heads	14951 : 2001	Specification for fire extinguisher, 135 litre capacity mechanical foam type
10204 : 1982	Specification for portable fire extinguisher mechanical foam type	15051 : 2002	Specification for high pressure fire hose delivery couplings
10460 : 1983	Functional requirements for small foam tender for fire brigade use	15105 : 2002	Design and installation of fixed automatic sprinkler fire extinguishing system
10658 : 1999	Specification for higher capacity dry powder fire extinguisher (trolley mounted)	15220 : 2002	Specification for halon 1211 and halon 1301 — Fire extinguishing media for fire protection
10993 : 1984	Functional requirements for 2000 kg dry powder tender for fire brigade use	15493 : 2004	Gaseous fire extinguishing systems — General requirements
11070 : 1984	Specification for bromo chlorodifluoromethane (Halon-1211) for fire fighting	15497 : 2004	Specification for gaseous fire extinguishing system — IG 01 extinguishing system
11101 : 1984	Specification for extended branch pipe for fire brigade use	15501 : 2004	Specification for gaseous fire extinguishing system — IG 541 extinguishing system
11108 : 1984	Specification for portable fire extinguisher halon-1211 type	15505 : 2004	Gaseous fire extinguishing systems — HCFC blend A extinguishing systems
11360 : 1985	Specification for smoke detectors for use in automatic electrical fire alarm systems	15506 : 2004	Specification for inert gaseous total fire protection total flooding system — Argonite, IG 55 extinguishing system
11833 : 1986	Specification for dry powder fire extinguisher for metal fires	15517 : 2004	Gaseous fire extinguishing systems — HFC 227 (heptafluoro propane) extinguishing system

<i>IS No.</i>	<i>Title</i>	<i>IS No.</i>	<i>Title</i>
15519 : 2004	Code of practice for water mist fire protection systems — System design, installation and commissioning		ginning and pressing (including cotton seed delinting) factories (<i>first revision</i>)
15525 : 2004	Specification for gaseous fire extinguishing system — IG 100 extinguishing system	3034 : 1993	Code of practice for fire safety of industrial buildings: Electrical generating and distributing stations (<i>second revision</i>)
15528 : 2004	Gaseous fire extinguishing systems — Carbon dioxide, total flooding and local application (sub-floor and in-cabinet), high and low pressure (refrigerated) systems	3058 : 1990	Code of practice for fire safety of industrial buildings: Viscose rayon yarn and/or staple fibre plants (<i>first revision</i>)
(20) 2190 : 1992	Code of practice for selection, installation and maintenance of portable first-aid fire extinguishers (<i>third revision</i>)	3079 : 1990	Code of practice for fire safety of industrial buildings: Cotton textile mills (<i>first revision</i>)
(21) 884 : 1985	Specification for first-aid hose reel for fire fighting (<i>first revision</i>)	3594 : 1991	Code of practice for fire safety of industrial buildings: General storage and warehousing including cold storage (<i>first revision</i>)
15517 : 2004	Code of practice for inspection and maintenance of gaseous fire extinguishing systems	3595 : 1984	Code of practice for fire safety of industrial buildings: Coal pulverizers and associated equipment (<i>first revision</i>)
(22) 3034 : 1993	Code of practice for fire safety of industrial buildings: Electrical generating and distributing stations (<i>second revision</i>)	3836 : 2000	Code of practice for fire safety of industrial buildings: Jute mills (<i>second revision</i>)
(23) 6382 : 1984	Code of practice for design and installation of fixed carbon dioxide fire extinguishing system (<i>first revision</i>)	4209 : 1987	Code of safety in chemical laboratories (<i>first revision</i>)
(24) 14609 : 2001	Specification for dry powder for fire fighting — Class ABC fires	4226 : 1988	Code of practice for fire safety of industrial buildings: Aluminium/Magnesium powder factories (<i>first revision</i>)
15493 : 2004	General requirement for commissioning of gaseous fire extinguishing systems	4886 : 1991	Code of practice for fire safety of industrial buildings: Tea factories (<i>first revision</i>)
(25) 13716 : 1993	Code of practice for fire safety in hotels	6329 : 2000	Code of practice for fire safety of industrial buildings: Saw mills and wood works (<i>first revision</i>)
(26) 4963 : 1987	Recommendations for buildings and facilities for the physically handicapped (<i>first revision</i>)	9109 : 2000	Code of practice for fire safety of industrial buildings: Paint and varnish factories
(27) 4878 : 1986	Bye-laws for construction of cinema buildings (<i>first revision</i>)	11457 (Part 1) : 1985	Code of practice for fire safety of chemical industries: Part 1 Rubber and plastic
(28) 12456 : 1988	Code of practice for fire protection of electronic data processing installations	11460 : 1985	Code of practice for fire safety of libraries and archives buildings
(29) 1646 : 1997	Code of practice for fire safety of buildings (general) : Electrical installations (<i>second revision</i>)	12349 : 1988	Fire protection — Safety signs
2726 : 1988	Code of practice for fire safety of industrial buildings: Cotton	12407 : 1988	Graphic symbols for fire protection plans

<i>IS No.</i>	<i>Title</i>	<i>IS No.</i>	<i>Title</i>
12456 : 1988	Code of practice for fire protection of electronic data processing installation	13694 : 1993	Code of practice for fire safety in iron and steel industries
12458 : 1988	Method of test for fire resistance test of fire stops	13716 : 1993	Code of practice for fire safety of hotels
12459 : 1988	Code of practice for fire-protection of cable runs	14435 : 1997	Code of practice for fire safety in educational institutions
12777 : 1989	Fire safety — Flame spread of products — Method for classification	14689 : 1999	Code of practice for fire safety in printing and publishing industry
13045 : 1991	Code of practice for fire safety in industrial buildings: Floor mills	14850 : 2000	Code of practice for fire safety of museums
		(30) 655 : 1963	Specification for metal air ducts (<i>revised</i>)
		(31) 9583 : 1981	Emergency lighting units

NATIONAL BUILDING CODE OF INDIA

PART 5 BUILDING MATERIALS

BUREAU OF INDIAN STANDARDS

CONTENTS

FOREWORD	...	3
1 SCOPE	...	5
2 MATERIALS	...	5
3 NEW OR ALTERNATIVE MATERIALS	...	5
4 THIRD PARTY CERTIFICATION	...	5
5 USED MATERIALS	...	5
6 STORAGE OF MATERIALS	...	5
7 METHODS OF TEST	...	5
LIST OF STANDARDS	...	6

FOREWORD

Ensuring the quality and effectiveness of building materials used in the construction and their storage are as important as the other phases of building activity like planning, designing and constructing the building itself. This Part, therefore, lists Indian Standards for materials used in building construction. The methods of tests, to ensure the requirements demanded of the materials in the various situations, are also included.

Historically choice of building materials was determined by what was locally available, appropriateness to geo-climatic conditions and affordability of users. In recent past, different initiatives have been taken in the areas of research and development, standardization, and development and promotion of innovative materials. A review of the recent trends indicates that the growth in the area of building materials covers emerging trends and latest developments in the use of wastes, mineral admixtures in cement and concrete, substitutes to conventional timber, composite materials and recycling of wastes, at the same time ensuring desired response of materials to fire, long term performance and durability. In addition to these developments, the future decade may witness development of specific materials which may be structured and designed to meet needs to specially developed construction technologies, such as, for disaster prone areas or aggressive climatic and industrial situations.

In this context, the following factors have become important for facilitating application and adoption in practice, of the materials:

- a) Utilization of industrial, mining, mineral and agricultural wastes; plantation timbers; and renewable natural fibres and residues for production of building materials.
- b) Impact of production of building materials on the consumption levels of natural resources.
- c) Change in energy demand in production of building materials due to development of efficient manufacturing processes.
- d) Impact of production and usage of materials and disposal thereof on the environment.

To encourage use of appropriate materials, it may be desirable to have, to the extent possible, performance oriented approach for specifications rather than prescriptive approach. The approach has been already adopted in some cases in development of standards, wherever found possible.

Indian Standards cover most of the requirements for materials in use. However, there may be a gap between development of new materials and techniques of application and formulation of standards. It, therefore, becomes necessary for a Building Code to be flexible to recognize building materials other than those for which Indian Standards are available. This Part, therefore, since its first version, duly takes care of this aspect and explicitly provides for use of new or alternate building materials, provided it is proved by authentic tests that the new or alternative material is effective and suitable for the purpose intended. However, it is worthwhile that more and more emphasis is given to the satisfaction of performance requirements expected of a building material, so that a wide range of such new or alternate materials can be evaluated and used, if found appropriate.

As already emphasized, quality of material is quite important for their appropriate usage, whether it is a material for which an Indian Standard is available or a new or alternative material as defined in **3** of this Part. Third party certification schemes available in the country for quality assurance of above materials can be used with advantage to ensure the appropriateness of these materials.

This Part of the Code was first published in 1970 and subsequently revised in 1983. The first revision of this Part incorporated an updated version of the list of Indian Standards given at the end of this Part of the Code. The present draft revision of this Part, while basically retaining the structure of 1983 version of the Code, explicitly takes care of the following:

- a) While continuing to emphasize on conformity of building materials to available Indian Standards, the building regulating authority also recognizes use of building materials conforming to other specifications and test methods (*see 3*), in case Indian Standards are not available for particular materials.

- b) The list at the end of this part has been completely reclassified to make it more user friendly and updated to reflect the latest available Indian Standard and methods of test.

A reference to SP 21 'Summaries of Indian Standards for building materials' may be useful. This publication gives the summaries of Indian Standards covering various building materials, fittings and components except standards relating to paints.

All standards cross-referred to in the main text of this Part, are subject to revision. The parties to agreement based on this section are encouraged to investigate the possibility of applying the most recent editions of the standards.

NATIONAL BUILDING CODE OF INDIA

PART 5 BUILDING MATERIALS

1 SCOPE

This Part of the Code covers the requirements of building materials and components, and criteria for accepting new or alternative building materials and components.

2 MATERIALS

Every material used in fulfilment of the requirements of this Part, unless otherwise specified in the Code or approved, shall conform to the relevant Indian Standards. A list of Indian Standards as the 'accepted standards' is given at the end of this Part of the Code. At the time of publication of the Code, the editions indicated were valid. All standards are subject to amendments and revisions. The Authority shall take cognizance of such amendments and revisions. The latest version of a standard shall, as far as possible, be adopted at the time of enforcement of this Part of the Code.

3 NEW OR ALTERNATIVE MATERIALS

3.1 The provisions of this Part are not intended to prevent the use of any material not specifically prescribed under **2**. Any such material may be approved by the Authority or an agency appointed by them for the purpose, provided it is established that the material is satisfactory for the purpose intended and the equivalent of that required in this Part or any other specification issued or approved by the Authority. The Authority or an agency appointed by them shall take into account the following parameters, as applicable to the concerned new or alternative building material:

- a) Requirements of the material specified/expected in terms of the provisions given in the standards on its usage, including its applicability in geo-climatic condition;
- b) General appearance;
- c) Dimension and dimensional stability;
- d) Structural stability including strength properties;
- e) Fire safety;
- f) Durability;
- g) Thermal properties;
- h) Mechanical properties;
- j) Acoustical properties;
- k) Optical properties;
- m) Biological effect;
- n) Environmental aspects;
- p) Working characteristics;
- q) Ease of handling; and
- r) Consistency and workability.

For establishing the performance of the material/

component, laboratory/field tests, and field trials, as required, and study of historical data are recommended.

3.2 Approval in writing of the Authority or an agent appointed by them for the purpose of approval of material, shall be obtained by the owner or his agent before any new, alternative or equivalent material is used. The Authority or their agent shall base such approval on the principle set forth in **3.1** and shall require that tests be made (*see 7.1*) or sufficient evidence or proof be submitted, at the expense of the owner or his agent, to substantiate any claim for the proposed material.

NOTE — For interpretation of the term 'Authority' (*see also 7.1*), the definition of 'Authority having jurisdiction' given in Part 2 'Administration' shall apply.

4 THIRD PARTY CERTIFICATION

For ensuring the conformity of materials for which Indian Standards exist and for new or alternative building materials, to requisite quality parameters the services under the third party certification schemes of the Government, may be utilized with advantage.

5 USED MATERIALS

The use of used materials may not be precluded provided these meet the requirements of this Part for new materials (*see Part 2 'Administration'*).

6 STORAGE OF MATERIALS

All building materials shall be stored on the building site in such a way as to prevent deterioration or the loss or impairment of their structural and other essential properties (*see Part 7 'Constructional Practices and Safety'*).

7 METHODS OF TEST

7.1 Every test of material required in this Part or by the Authority shall be carried out in accordance with the Indian Standard methods of test. In the case of methods of tests where Indian Standards are not available, the same shall conform to the methods of tests issued by the Authority or their agent. A list of Indian Standard methods of test is given at the end of this Part of the Code as the 'good practices'. Laboratory tests shall be conducted by recognized laboratories acceptable to the Authority.

7.1.1 The manufacturer/supplier shall satisfy himself that materials conform to the requirements of the specifications and if requested shall supply a certificate to this effect to the purchaser or his representative. When such test certificates are not available, the specimen of the material shall be tested.

LIST OF STANDARDS

Following are the Indian Standards for various building materials and components, to be complied with in fulfillment of the requirements of the Code.

In the following list, while enlisting the Indian Standards, the materials have been categorized in such a way as to make the list user friendly. In the process, if so required, some of the standards have been included even in more than one category of products, such as in the category based on composition as well as on end application of the materials. The list has been arranged in alphabetical order of their principal category as given below:

1. ALUMINIUM AND OTHER LIGHT METALS AND THEIR ALLOYS
2. BITUMEN AND TAR PRODUCTS
3. BUILDER'S HARDWARES
4. BUILDING CHEMICALS
5. BUILDING LIME AND PRODUCTS
6. BURNT CLAY PRODUCTS
7. CEMENT AND CONCRETE (including concrete reinforcement)
8. COMPOSITE MATRIX PRODUCTS (including cement matrix products)
9. CONDUCTORS AND CABLES
10. DOORS, WINDOWS AND VENTILATORS
11. ELECTRICAL WIRING, FITTINGS AND ACCESSORIES
12. FILLERS, STOPPERS AND PUTTIES
13. FLOOR COVERING, ROOFING AND OTHER FINISHES
14. GLASS
15. GYPSUM BASED MATERIALS
16. LIGNOCELLULOSIC BUILDING MATERIALS (including timber, bamboo and products thereof)
17. PAINTS AND ALLIED PRODUCTS
18. POLYMERS, PLASTICS AND GEOSYNTHETICS/GEOTEXTILES
19. SANITARY APPLIANCES AND WATER FITTINGS
20. SOIL-BASED PRODUCTS
21. STEEL AND ITS ALLOYS
22. STONES
23. STRUCTURAL SECTIONS
24. THERMAL INSULATION MATERIALS
25. THREADED FASTENERS AND RIVETS
26. UNIT WEIGHTS OF BUILDING MATERIALS
27. WATERPROOFING AND DAMP-PROOFING MATERIALS
28. WELDING ELECTRODES AND WIRES

29. WIRE ROPES AND WIRE PRODUCTS

1. ALUMINIUM AND OTHER LIGHT METALS AND THEIR ALLOYS

<i>IS No.</i>	<i>Title</i>
733 : 1983	Specification for wrought aluminium and aluminium alloys, bars, rods and sections for general engineering purposes (<i>third revision</i>)
737 : 1986	Specification for wrought aluminium and aluminium alloys, sheet rods and strip for general engineering purposes (<i>third revision</i>)
738 : 1994	Specification for wrought aluminium and aluminium alloy drawn tube for general engineering purposes (<i>third revision</i>)
740 : 1977	Specification for wrought aluminium and aluminium alloy rivet stock for general engineering purposes (<i>second revision</i>)
1254 : 1991	Specification for corrugated aluminium sheet (<i>third revision</i>)
1284 : 1975	Wrought aluminium alloy bolt and screw stock for general engineering purposes (<i>second revision</i>)
1285 : 2002	Specification for wrought aluminium and aluminium alloys, extruded round tube and hollow sections for general engineering purposes (<i>third revision</i>)
2479 : 1981	Colour code for the identification of aluminium and aluminium alloys for general engineering purposes (<i>second revision</i>)
2676 : 1981	Dimensions for wrought aluminium and aluminium alloy sheet and strip
2677 : 1979	Dimensions for wrought aluminium and aluminium alloys, plates and hot rolled sheets
14712 : 1999	Wrought aluminium and its alloys — Chequered/tread sheets for general engineering purposes — Specification
2. BITUMEN AND TAR PRODUCTS	
73 : 1992	Specification for paving bitumen (<i>second revision</i>)

<i>IS No.</i>	<i>Title</i>	<i>IS No.</i>	<i>Title</i>
212 : 1983	Specification for crude coal tar for general use (<i>second revision</i>)	1218 : 1978	Determination of phenols (<i>first revision</i>)
215 : 1995	Specification for road tar (<i>third revision</i>)	1219 : 1978	Determination of naphthalene (<i>first revision</i>)
216 : 1961	Specification for coal tar pitch (<i>first revision</i>)	1220 : 1978	Determination of volatile matter content (<i>first revision</i>)
217 : 1988	Specification for cutback bitumen (<i>second revision</i>)	3117 : 2004	Specification for bitumen emulsion for roads (anionic type) (<i>first revision</i>)
218 : 1983	Specification for creosote oil for use as wood preservatives (<i>second revision</i>)	8887 : 2004	Specification for bitumen emulsion for roads (cationic type) (<i>second revision</i>)
454 : 1994	Specification for cutback bitumen from waxy crude (<i>second revision</i>)	9381 : 1979	Methods for testing tar and bituminous materials: Determination of FRAASS breaking point of bitumen
702 : 1988	Specification for industrial bitumen (<i>second revision</i>)	9382 : 1979	Methods for testing tar and bituminous materials: Determination of effect of heat and air by thin film oven test
1201 to 1220	Methods for testing tar and bituminous materials	10511 : 1983	Method for determination of asphaltenes in bitumen by precipitation with normal heptane
1201 : 1978	Sampling (<i>first revision</i>)	10512 : 2003	Method for determination of wax content in bitumen (<i>first revision</i>)
1202 : 1978	Determination of specific gravity (<i>first revision</i>)	13758	Coal tar pitch:
1203 : 1978	Determination of penetration (<i>first revision</i>)	(Part 1) : 1993	Determination of matter insoluble in quinoline
1204 : 1978	Determination of residue of specified penetration (<i>first revision</i>)	(Part 2) : 1993	Determination of coking value
1205 : 1978	Determination of softening point (<i>first revision</i>)	15172 : 2002	Methods for testing tar and bituminous materials — Determination of curing index for cutback bitumens
1206	Determination of viscosity:	15173 : 2002	Methods for testing tars and bituminous materials — Determination of breaking point for cationic bitumen emulsion
(Part 1) : 1978	Industrial viscosity (<i>first revision</i>)	15174 : 2002	Methods for testing tar and bituminous material — Determination of breaking point for anionic bitumen emulsion
(Part 2) : 1978	Absolute viscosity (<i>first revision</i>)	15462 : 2004	Specification for polymer and rubber modified bitumen
(Part 3) : 1978	Kinematic viscosity (<i>first revision</i>)		
1207 : 1978	Determination of equiviscous temperature (EVT) (<i>first revision</i>)		
1208 : 1978	Determination of ductility (<i>first revision</i>)		
1209 : 1978	Determination of flash point and fire point (<i>first revision</i>)		
1210 : 1978	Float test (<i>first revision</i>)		
1211 : 1978	Determination of water content (Dean and Stark method) (<i>first revision</i>)		
1212 : 1978	Determination of loss of heating (<i>first revision</i>)		
1213 : 1978	Distillation test (<i>first revision</i>)		
1215 : 1978	Determination of matter insoluble in toluene (<i>first revision</i>)	3. BUILDER'S HARDWARE	
1216 : 1978	Determination of solubility in carbon disulphide or trichloroethylene (<i>first revision</i>)	204	Specification for tower bolts:
1217 : 1978	Determination of mineral matter (ASH) (<i>first revision</i>)	(Part 1) : 1991	Ferrous metals (<i>fifth revision</i>)
		(Part 2) : 1992	Non-ferrous metals (<i>fifth revision</i>)
		205 : 1992	Specification for non-ferrous metal butt hinges (<i>fourth revision</i>)

<i>IS No.</i>	<i>Title</i>	<i>IS No.</i>	<i>Title</i>
206 : 1992	Specification for tee and strap hinges (<i>fourth revision</i>)	4992 : 1975	Specification for door handles for mortice locks (vertical type) (<i>first revision</i>)
208 : 1996	Specification for door handles (<i>fifth revision</i>)	5187 : 1972	Specification for flush bolts (<i>first revision</i>)
281 : 1991	Specification for mild steel sliding door bolts for use with padlock (<i>third revision</i>)	5899 : 1970	Specification for bathroom latches
362 : 1991	Specification for parliament hinges (<i>fifth revision</i>)	5930 : 1970	Specification for mortice latch (vertical type)
363 : 1993	Specification for hasps and staples (<i>fourth revision</i>)	6315 : 1992	Specification for floor springs (hydraulically regulated) for heavy doors (<i>second revision</i>)
364 : 1993	Specification for fanlight catch (<i>third revision</i>)	6318 : 1971	Specification for plastic window stays and fasteners
452 : 1973	Specification for door springs, rat-tail type (<i>second revision</i>)	6343 : 1982	Specification for door closers (pneumatically regulated) for light door weighing up to 40 kg (<i>first revision</i>)
453 : 1993	Specification for double-acting spring hinges (<i>third revision</i>)	6607 : 1972	Specification for rebated mortice locks (vertical type)
729 : 1979	Specification for drawer locks, cupboard locks and box locks (<i>third revision</i>)	7196 : 1974	Specification for hold fast
1019 : 1974	Specification for rim latches (<i>second revision</i>)	7197 : 1974	Specification for double action floor springs (without oil check) for heavy doors
1341 : 1992	Specification for steel butt hinges (<i>sixth revision</i>)	7534 : 1985	Specification for sliding locking bolts for use with padlocks (<i>first revision</i>)
1823 : 1980	Specification for floor door stoppers (<i>third revision</i>)	7540 : 1974	Specification for mortice dead locks
1837 : 1966	Specification for fanlight pivots (<i>first revision</i>)	8756 : 1978	Specification for ball catches for use in wooden almirah
2209 : 1976	Specification for mortice locks (vertical type) (<i>third revision</i>)	8760 : 1978	Specification for mortice sliding door locks, with lever mechanism
2681 : 1993	Specification for non-ferrous metal sliding door bolts for use with padlocks (<i>third revision</i>)	9106 : 1979	Specification for rising butt hinges
3564 : 1995	Specification for door closers (hydraulically regulated) (<i>second revision</i>)	9131 : 1979	Specification for rim locks
3818 : 1992	Specification for continuous (piano) hinges (<i>third revision</i>)	9460 : 1980	Specification for flush drop handle for drawer
3828 : 1966	Specification for ventilator chains	9899 : 1981	Specification for hat coat and wardrobe hooks
3843 : 1995	Specification for steel backflap hinges (<i>first revision</i>)	10019 : 1981	Specification for mild steel stays and fasteners
3847 : 1992	Specification for mortice night latches (<i>first revision</i>)	10090 : 1982	Specification for numericals
4621 : 1975	Specification for indicating bolts for use in public baths and lavatories (<i>first revision</i>)	10342 : 1982	Specification for curtain rail system
4948 : 2002	Specification for welded steel wire fabric for general use (<i>second revision</i>)	12817 : 1997	Specification for stainless steel butt hinges (<i>first revision</i>)
		12867 : 1989	Specification for PVC hand rails covers
		14912 : 2001	Specification for door closers concealed type (hydraulically regulated)

<i>IS No.</i>	<i>Title</i>	<i>IS No.</i>	<i>Title</i>
4. BUILDING CHEMICALS		1508 : 1972	Specification for extenders for use in synthetic resin adhesives (urea-formaldehyde) for plywood (<i>first revision</i>)
a) Anti-termite Chemicals		4835 : 1979	Specification for polyvinyl acetate dispersion-based adhesives for wood (<i>first revision</i>)
632 : 1978	Specification for gamma-BHC (lindane) emulsifiable concentrates (<i>fourth revision</i>)	9188 : 1979	Performance requirements for adhesive for structural laminated wood products for use under exterior exposure condition
8944 : 1978	Specification for chlorpyrifos emulsifiable concentrates	12830 : 1989	Rubber based adhesives for fixing PVC tiles to cement
b) Chemical Admixture/Water Proofing Compounds		12994 : 1990	Epoxy adhesives, room temperature curing general purpose
2645 : 2003	Specification for integral waterproofing compounds for cement mortar and concrete (<i>second revision</i>)	5. BUILDING LIME AND PRODUCTS	
6925 : 1973	Methods of test for determination of water soluble chlorides in concrete admixtures	712 : 1984	Specification for building limes (<i>third revision</i>)
9103 : 1999	Specification for concrete admixtures (<i>first revision</i>)	1624 : 1986	Method of field testing of building lime (<i>first revision</i>)
c) Sealants/Fillers		2686 : 1977	Specification for cinder as fine aggregates for use in lime concrete (<i>first revision</i>)
1834 : 1984	Specification for hot applied sealing compound for joint in concrete (<i>first revision</i>)	3068 : 1986	Specification for broken brick (burnt-clay) coarse aggregates for use in lime concrete (<i>second revision</i>)
1838	Specification for preformed fillers for expansion joint in concrete pavements and structures (non-extruding and resilient type):	3115 : 1992	Specification for lime based blocks (<i>second revision</i>)
(Part 1) : 1983	Bitumen impregnated fibre (<i>first revision</i>)	3182 : 1986	Specification for broken bricks (burnt clay) fine aggregates for use in lime mortar (<i>second revision</i>)
(Part 2) : 1984	CNSL aldehyde resin and coconut pith	4098 : 1983	Specification for lime-pozzolana mixture (<i>first revision</i>)
11433	Specification for one grade polysulphide based joint sealant: Part 1 General requirements	4139 : 1989	Specification for calcium silicate bricks (<i>second revision</i>)
(Part 1) : 1985		6932	Method of tests for building limes: Determination of insoluble residue, loss on ignition, insoluble matter, silicon dioxide, ferric and aluminium oxide, calcium oxide and magnesium oxide
12118	Specification for two parts polysulphide based sealants:	(Part 1) : 1973	
(Part 1) : 1987	General requirements	(Part 2) : 1973	Determination of carbon dioxide content
(Part 2) : 1987	Methods of test	(Part 3) : 1973	Determination of residue on slaking of quicklime
d) Adhesives		(Part 4) : 1973	Determination of fineness of hydrated lime
848 : 1974	Specification for synthetic resin adhesives for plywood (phenolic and aminoplastic) (<i>first revision</i>)	(Part 5) : 1973	Determination of unhydrated oxide
849 : 1994	Specification for cold setting case in glue for wood (<i>first revision</i>)		
851 : 1978	Specification for synthetic resin adhesives for construction work (non-structural) in wood (<i>first revision</i>)		
852 : 1994	Specification for animal glue for general wood-working purposes (<i>second revision</i>)		

<i>IS No.</i>	<i>Title</i>	<i>IS No.</i>	<i>Title</i>
(Part 6) : 1973	Determination of volume yield of quicklime	6165 : 1992	Dimensions for special shapes of clay bricks (<i>first revision</i>)
(Part 7) : 1973	Determination of compressive and transverse strength	11650 : 1991	Guide for manufacture of common burnt clay building bricks by semi-mechanized process (<i>first revision</i>)
(Part 8) : 1973	Determination of workability		
(Part 9) : 1973	Determination of soundness	13757 : 1993	Specification for burnt clay fly ash building bricks
(Part 10) : 1973	Determination of popping and pitting of hydrated lime		
(Part 11) : 1984	Determination of setting time of hydrated lime	d) Jallies	
10360 : 1982	Specification for lime pozzolana concrete blocks for paving	7556 : 1988	Specification for burnt clay jallies (<i>first revision</i>)
10772 : 1983	Specification for quick setting lime pozzolana mixture	e) Tiles	
12894 : 2002	Specification for pulverized fuel ash lime bricks (<i>first revision</i>)	654 : 1992	Specification for clay roofing tiles, Mangalore pattern (<i>third revision</i>)
		1464 : 1992	Specification for clay ridge and ceiling tiles (<i>second revision</i>)
		1478 : 1992	Specification for clay flooring tiles (<i>second revision</i>)
		2690	Specification for burnt clay flat terracing tiles:
		(Part 1) : 1993	Machine made (<i>second revision</i>)
		(Part 2) : 1992	Handmade (<i>second revision</i>)
		3367 : 1993	Specification for burnt clay tiles for use in lining irrigation and drainage works (<i>second revision</i>)
		3951	Specification for hollow clay tiles for floor and roofs:
		(Part 1) : 1975	Filler type (<i>first revision</i>)
		(Part 2) : 1975	Structural type (<i>first revision</i>)
		13317 : 1992	Specification for clay roofing camty tiles, half round and flat tiles
6. BURNT CLAY PRODUCTS			
a) Blocks			
3952 : 1988	Specification for burnt hollow bricks for walls and partitions (<i>second revision</i>)		
b) Soil-Based Products			
1725 : 1982	Specification for soil-based blocks used in general building construction		
c) Bricks			
1077 : 1992	Specification for common burnt clay building bricks (<i>fifth revision</i>)		
2117 : 1991	Guide for manufacture of hand-made-common burnt clay building bricks (<i>third revision</i>)		
2180 : 1988	Specification for heavy duty burnt clay building bricks (<i>third revision</i>)		
2222 : 1991	Specification for burnt clay perforated building bricks (<i>fourth revision</i>)		
2691 : 1988	Specification for burnt clay facing bricks (<i>second revision</i>)		
3495 (Parts 1 to 4) : 1992	Methods of test of burnt clay building bricks (<i>third revision</i>)		
3583 : 1988	Specification for burnt clay paving bricks (<i>second revision</i>)		
4885 : 1988	Specification for sewer bricks (<i>first revision</i>)		
5454 : 1978	Methods for sampling of clay building bricks		
5779 : 1986	Specification for burnt clay soling bricks (<i>first revision</i>)		
		7. CEMENT AND CONCRETE (including concrete reinforcement)	
		a) Aggregates	
		383 : 1970	Specification for coarse and fine aggregates from natural sources for concrete (<i>second revision</i>)
		1542 : 1992	Specification for sand for plaster (<i>second revision</i>)
		2116 : 1980	Specification for sand for masonry mortars (<i>first revision</i>)
		2386	Methods of test for aggregates for concrete:
		(Part 1) : 1963	Particle size and shape
		(Part 2) : 1963	Estimation of deleterious materials and organic impurities
		(Part 3) : 1963	Specific gravity, density, voids, absorption and bulking

<i>IS No.</i>	<i>Title</i>	<i>IS No.</i>	<i>Title</i>
(Part 4) : 1963	Mechanical properties	3812	Specification for pulverized fuel ash:
(Part 5) : 1963	Soundness		
(Part 6) : 1963	Measuring mortar making properties of fine aggregates	(Part 1) : 2003	For use as pozzolana in cement, cement mortar and concrete (<i>second revision</i>)
(Part 7) : 1963	Alkali aggregate reactivity	(Part 2) : 2003	For use as admixture in cement mortar and concrete (<i>second revision</i>)
(Part 8) : 1963	Petrographic examination		
2430 : 1986	Methods of sampling of aggregates of concrete (<i>first revision</i>)	6491 : 1972	Method of sampling of flyash
6579 : 1981	Specification for coarse aggregate for water bound macadam (<i>first revision</i>)	6925 : 1973	Methods of test for determination of water soluble chlorides in concrete admixtures
9142 : 1979	Specification for artificial light-weight aggregates for concrete masonry units	9103 : 1999	Specification for admixtures for concrete (<i>first revision</i>)
b) Cement		12089 : 1987	Specification for granulated slag for manufacture of Portland slag cement
269 : 1989	Specification for ordinary portland cement, 33 Grade (<i>fourth revision</i>)	12870 : 1989	Methods of sampling calcined clay pozzolana
455 : 1989	Specification for Portland slag cement (<i>fourth revision</i>)	15388 : 2003	Specification for silica fume
1489	Specification for Portland pozzolana cement:	d) Concrete	
(Part 1) : 1991	Flyash based (<i>third revision</i>)	456 : 2000	Code of practice for plain and reinforced concrete (<i>fourth revision</i>)
(Part 2) : 1991	Calcined clay based (<i>third revision</i>)	1343 : 1980	Code of practice for prestressed concrete (<i>first revision</i>)
3466 : 1988	Specification for masonry cement (<i>second revision</i>)	4926 : 2003	Code of practice for ready-mixed concrete (<i>third revision</i>)
6452 : 1989	Specification for high alumina cement for structural use (<i>first revision</i>)	e) Cement and Concrete Sampling and Methods of Test	
6909 : 1990	Specification for supersulphated cement	516 : 1959	Methods of test for strength of concrete
8041 : 1990	Specification for rapid hardening Portland cement (<i>second revision</i>)	1199 : 1959	Methods of sampling and analysis of concrete
8042 : 1989	Specification for white Portland cement (<i>second revision</i>)	2770	Methods of testing bond in reinforced concrete: Part 1 Pullout test
8043 : 1991	Specification for hydrophobic Portland cement (<i>second revision</i>)	(Part 1) : 1967	
8112 : 1989	Specification for 43 grade ordinary Portland cement (<i>first revision</i>)	3085 : 1965	Methods of test for permeability of cement mortar and concrete
12269 : 1987	Specification for 53 grade ordinary Portland cement	3535 : 1986	Methods of sampling hydraulic cement (<i>first revision</i>)
12330 : 1988	Specification for sulphate resisting Portland cement	4031	Methods of physical tests for hydraulic cement:
12600 : 1989	Specification for low heat Portland cement	(Part 1) : 1996	Determination of fineness by dry sieving (<i>second revision</i>)
c) Mineral/Chemical Admixtures and Pozzolanas		(Part 2) : 1999	Determination of fineness by specific surface by Blaine air permeability method (<i>second revision</i>)
1344 : 1981	Specification for calcined clay pozzolana (<i>second revision</i>)		
1727 : 1967	Methods of test for pozzolanic materials (<i>first revision</i>)		

<i>IS No.</i>	<i>Title</i>	<i>IS No.</i>	<i>Title</i>
(Part 3) : 1988	Determination of soundness (<i>first revision</i>)	12813 : 1989	Method of analysis of hydraulic cement by atomic absorption spectrophotometer
(Part 4) : 1988	Determination of consistency of standard cement paste (<i>first revision</i>)	13311	Methods of non-destructive testing of concrete:
(Part 5) : 1988	Determination of initial and final setting times (<i>first revision</i>)	(Part 1) : 1992	Ultrasonic pulse velocity
(Part 6) : 1988	Determination of compressive strength of hydraulic cement (other than masonry cement) (<i>first revision</i>)	(Part 2) : 1992	Rebound hammer
(Part 7) : 1988	Determination of compressive strength of masonry cement (<i>first revision</i>)	f) Treatment of Concrete Joints	
(Part 8) : 1988	Determination of transverse and compressive strength of plastic mortar using prism (<i>first revision</i>)	1834 : 1984	Specification for hot applied sealing compound for joint in concrete (<i>first revision</i>)
(Part 9) : 1988	Determination of heat of hydration (<i>first revision</i>)	1838	Specification for preformed fillers for expansion joint in concrete pavements and structures (non-extruding and resilient type):
(Part 10) : 1988	Determination of drying shrinkage (<i>first revision</i>)	(Part 1) : 1983	Bitumen impregnated fibre (<i>first revision</i>)
(Part 11) : 1988	Determination of density (<i>first revision</i>)	(Part 2) : 1984	CNSL aldehyde resin and coconut pith
(Part 12) : 1988	Determination of air content of hydraulic cement mortar (<i>first revision</i>)	10566 : 1983	Methods of test for preformed fillers for expansion joints in concrete paving and structural construction
(Part 13) : 1988	Measurement of water retentivity of masonry cement (<i>first revision</i>)	11433	Specification for one grade polysulphide based joint sealant:
(Part 14) : 1989	Determination of false set	(Part 1) : 1985	General requirements
(Part 15) : 1991	Determination of fineness by wet sieving	(Part 2) : 1986	Methods of test
4032 : 1985	Methods of chemical analysis for hydraulic cement (<i>first revision</i>)	12118	Specification for two parts polysulphide based sealants:
5816 : 1999	Method of test for splitting tensile strength of concrete (<i>first revision</i>)	(Part 1) : 1987	General requirements
8142 : 1976	Methods of test for determining setting time of concrete by penetration resistance	(Part 2) : 1987	Methods of test
9013 : 1978	Method of making, curing and determining compressive strength of accelerated cured concrete test specimens	g) Concrete Reinforcement	
9284 : 1979	Method of test for abrasion resistance of concrete	432	Specification for mild steel and medium tensile steel bars and hard drawn steel wire for concrete reinforcement:
12423 : 1988	Methods for colorimetric analysis of hydraulic cement	(Part 1) : 1982	Mild steel and medium tensile steel bars (<i>third revision</i>)
12803 : 1989	Methods of analysis of hydraulic cement by X-ray fluorescence spectrometer	(Part 2) : 1982	Hard drawn steel wire (<i>third revision</i>)
		1566 : 1982	Specification for hard drawn steel wire fabric for concrete reinforcement (<i>second revision</i>)
		1608 : 1995	Mechanical testing of materials — Tensile testing
		1785	Specification for plain hard drawn steel wire for prestressed concrete:

<i>IS No.</i>	<i>Title</i>	<i>IS No.</i>	<i>Title</i>
(Part 1) : 1983	Cold drawn stress-relieved wire (<i>second revision</i>)	6073 : 1971	Specification for autoclaved reinforced cellular concrete floor and roof slabs
(Part 2) : 1983	As drawn wire (<i>first revision</i>)	6441	Methods of test for autoclaved cellular concrete products:
1786 : 1985	Specification for high strength deformed steel bars and wires for concrete reinforcement (<i>third revision</i>)	(Part 1) : 1972	Determination of unit weight or bulk density and moisture content
2090 : 1983	Specification for high tensile steel bars used in prestressed concrete (<i>first revision</i>)	(Part 2) : 1972	Determination of drying shrinkage
6003 : 1983	Specification for indented wire for prestressed concrete (<i>first revision</i>)	(Part 4) : 1972	Corrosion protection of steel reinforcement in autoclaved cellular concrete
6006 : 1983	Specification for uncoated stress-relieved strand for prestressed concrete (<i>first revision</i>)	(Part 5) : 1972	Determination of compressive strength
10790	Methods of sampling of steel for prestressed and reinforced concrete:	(Part 6) : 1973	Strength, deformation and cracking of flexural members subject to bending-short duration loading test
(Part 1) : 1984	Prestressing steel	(Part 7) : 1973	Strength, deformation and cracking of flexural members subject to bending-sustained loading test
(Part 2) : 1984	Reinforcing steel	(Part 8) : 1973	Loading tests for flexural members in diagonal tension
13620 : 1993	Specification for fusion bonded epoxy coated reinforcing bars	(Part 9) : 1973	Jointing of autoclaved cellular concrete elements
14268 : 1995	Specification for uncoated stress relieved low relaxation seven ply strand for prestressed concrete	6523 : 1983	Specification for precast reinforced concrete door and window frames (<i>first revision</i>)
8. COMPOSITE MATRIX PRODUCTS		9872 : 1981	Specification for precast concrete septic tanks
a) Cement Matrix Products		9893 : 1981	Specification for precast concrete blocks for lintels and sills
i) Precast Concrete Products		12440 : 1988	Specification for precast concrete stone masonry blocks
2185	Specification for concrete masonry units:	12592 : 2002	Specification for precast concrete manhole covers and frames (<i>first revision</i>)
(Part 1) : 1979	Hollow and solid concrete blocks (<i>second revision</i>)	13356 : 1992	Specification for precast ferrocement water tanks (250 to 10 000 litres capacity)
(Part 2) : 1983	Hollow and solid lightweight concrete blocks (<i>first revision</i>)	13990 : 1994	Specification for precast reinforced concrete planks and joists for flooring and roofing
(Part 3) : 1984	Autoclaved cellular (aerated) concrete blocks (<i>first revision</i>)	14143 : 1994	Specification for prefabricated brick panel and partially precast concrete joist for flooring and roofing
4996 : 1984	Specification for reinforced concrete fence posts (<i>first revision</i>)	14201 : 1994	Specification for precast reinforced concrete channel unit for construction of floors and roofs
5751 : 1984	Specification for precast concrete coping blocks (<i>first revision</i>)	14241 : 1994	Specification for precast L-Panel units for roofing
5758 : 1984	Specification for precast concrete kerbs (<i>first revision</i>)		
5820 : 1970	Specification for precast concrete cable covers		
6072 : 1971	Specification for autoclaved reinforced cellular concrete wall slabs		

<i>IS No.</i>	<i>Title</i>	<i>IS No.</i>	<i>Title</i>
<i>ii) Asbestos Fibre Cement Products</i>		1916 : 1989	Specification for steel cylinder pipe with concrete lining and coating (<i>first revision</i>)
459 : 1992	Specification for corrugated and semi-corrugated asbestos cement sheets (<i>third revision</i>)	3597 : 1998	Methods of test for concrete pipes (<i>second revision</i>)
1592 : 2003	Specification for asbestos cement pressure pipes and joints (<i>fourth revision</i>)	4350 : 1967	Specification for concrete porous pipes for under drainage
1626	Specification for asbestos cement building pipes and pipe fittings, gutters and gutter fittings and roofing fittings:	7319 : 1974	Specification for perforated concrete pipes
(Part 1) : 1994	Pipes and pipe fittings (<i>second revision</i>)	7322 : 1985	Specification for specials for steel cylinder reinforced concrete pipes (<i>first revision</i>)
(Part 2) : 1994	Gutters and gutter fittings (<i>second revision</i>)	15155 : 2002	Specification for bar/wire wrapped steel cylinder pipe with mortar lining and coating
(Part 3) : 1994	Roofing fittings (<i>second revision</i>)	b) Resin Matrix Products	
2096 : 1992	Specification for asbestos cement flat sheets (<i>first revision</i>)	1998 : 1962	Methods of test for thermosetting synthetic resin bonded laminated sheets
2098 : 1997	Specification for asbestos cement building boards (<i>first revision</i>)	2036 : 1995	Specification for phenolic laminated sheets (<i>second revision</i>)
5913 : 2003	Methods of test for asbestos cement products (<i>second revision</i>)	2046 : 1995	Specification for decorative thermosetting synthetic resin bonded laminated sheets (<i>second revision</i>)
6908 : 1991	Specification for asbestos cement pipes and fittings for sewerage and drainage (<i>first revision</i>)	9. CONDUCTORS AND CABLES	
7639 : 1975	Method of sampling asbestos cement products	694 : 1990	Specification for PVC insulated cables for working voltages up to and including 1 100 V (<i>third revision</i>)
9627 : 1980	Specification for asbestos cement pressure pipes (light duty)	1554	Specification for PVC insulated (heavy duty) electric cables:
13000 : 1990	Silica-asbestos-cement flat sheets — Specification	(Part 1) : 1988	For working voltages up to and including 1 100 V (<i>third revision</i>)
13008 : 1990	Specification for shallow corrugated asbestos cement sheets	(Part 2) : 1988	For working voltages from 3.3 kV up to and including 11 kV (<i>second revision</i>)
<i>iii) Other Fibre Cement Products</i>		4289	Specification for flexible cables for lifts and other flexible:
14862 : 2000	Specification for fibre cement flat sheets	(Part 1) : 1984	Elastomer insulated cables (<i>first revision</i>)
14871 : 2000	Specification for products in fibre reinforced cement long corrugated or asymmetrical section sheets and fittings for roofing and cladding	(Part 2) : 2000	PVC insulated circular cables
<i>iv) Concrete Pipes and Pipes Lined/Coated with Concrete or Mortar</i>		7098	Specification for cross-linked polyethylene insulated PVC sheathed cables:
458 : 2003	Specification for precast concrete pipes (with and without reinforcement) (<i>fourth revision</i>)	(Part 1) : 1988	For working voltage up to and including 1 100 V (<i>second revision</i>)
784 : 2001	Specification for prestressed concrete pipes (including specials) (<i>second revision</i>)		

<i>IS No.</i>	<i>Title</i>	<i>IS No.</i>	<i>Title</i>
(Part 2) : 1985	For working voltages from 3.3 kV up to and including 33 kV (<i>first revision</i>)	(Part 24) : 1984	Water soluble impurities test of insulating paper
(Part 3) : 1993	For working voltages from 66 kV up to and including 220 kV (<i>first revision</i>)	(Part 25) : 1984	Conductivity of water extract test of insulating paper
9968	Specification for elastomer-insulated cables:	(Part 26) : 1984	pH value of water extract test of insulating paper
(Part 1) : 1988	For working voltages up to and including 1 100 V (<i>first revision</i>)	(Part 27) : 1984	Ash content test of insulating paper
(Part 2) : 2002	For working voltages from 3.3 kV up to and including 33 kV (<i>first revision</i>)	(Part 28) : 1984	Water absorption test (Electrical)
10810	Methods of test for cables	(Part 29) : 1984	Environmental stress cracking test
(Part 0) : 1984	General	(Part 30) : 1984	Hot set test
(Part 1) : 1984	Annealing test for wires used in conductors	(Part 31) : 1984	Oil resistance test
(Part 2) : 1984	Tensile test for aluminium wires	(Part 32) : 1984	Carbon content test for polyethylene
(Part 3) : 1984	Wrapping test for aluminium wires	(Part 33) : 1984	Water absorption test (Gravimetric)
(Part 4) : 1984	Persulphate test of conductor	(Part 34) : 1984	Measurement of thickness of metallic sheath
(Part 5) : 1984	Conductor resistance test	(Part 35) : 1984	Determination of tin in lead alloy for sheathing
(Part 6) : 1984	Thickness of thermoplastic and elastomeric insulation and sheath	(Part 36) : 1984	Dimensions of armouring material
(Part 7) : 1984	Tensile strength and elongation at break of thermoplastic and elastomeric insulation and sheath	(Part 37) : 1984	Tensile strength and elongation at break of armouring materials
(Part 8) : 1984	Breaking strength and elongation at break for impregnated paper insulation	(Part 38) : 1984	Torsion test on galvanized steel wires for armouring
(Part 9) : 1984	Tear resistance for paper insulation	(Part 39) : 1984	Winding test on galvanized steel strips for armouring
(Part 10) : 1984	Loss of mass test	(Part 40) : 1984	Uniformity of zinc coating on steel armour
(Part 11) : 1984	Thermal ageing in air	(Part 41) : 1984	Mass of zinc coating on steel armour
(Part 12) : 1984	Shrinkage test	(Part 42) : 1984	Resistivity test of armour wires and strips and conductance test of armour (wires/strips)
(Part 13) : 1984	Ozone resistance test	(Part 43) : 1984	Insulation resistance
(Part 14) : 1984	Heat shock test	(Part 44) : 1984	Spark test
(Part 15) : 1984	Hot deformation test	(Part 45) : 1984	High voltage test
(Part 16) : 1986	Accelerated ageing test by oxygen pressure method	(Part 46) : 1984	Partial discharge test
(Part 17) : 1986	Tear resistance test for heavy duty sheath	(Part 47) : 1984	Impulse test
(Part 18) : 1984	Colour fastness to day light	(Part 48) : 1984	Dielectric power factor test
(Part 19) : 1984	Bleeding and blooming test	(Part 49) : 1984	Heating cycle test
(Part 20) : 1984	Cold bend test	(Part 50) : 1984	Bending test
(Part 21) : 1984	Cold impact test	(Part 51) : 1984	Dripping test
(Part 22) : 1984	Vicat softening point	(Part 52) : 1984	Drainage test
(Part 23) : 1984	Melt-flow index	(Part 53) : 1984	Flammability test
		(Part 54) : 1984	Static flexibility test
		(Part 55) : 1986	Abrasion test
		(Part 56) : 1987	Accelerated ageing by the air-pressure method

<i>IS No.</i>	<i>Title</i>	<i>IS No.</i>	<i>Title</i>
15380 : 2003	Specification for moulded raised high density fibre (HDF) panel doors	2215 : 1983	Specification for starters for fluorescent lamps (<i>third revision</i>)
		2412 : 1975	Specification for link clips for electrical wiring (<i>first revision</i>)
11. ELECTRICAL WIRING FITTINGS AND ACCESSORIES			
371 : 1999	Specification for ceiling roses (<i>third revision</i>)	2418	Specification for tubular fluorescent lamps for general lighting services:
374 : 1979	Specification for electric ceiling type fans and regulators (<i>third revision</i>)	(Part 1) : 1977	Requirements and tests (<i>first revision</i>)
418 : 1978	Specification for tungsten filament general service electric lamps (<i>third revision</i>)	(Part 2) : 1977	Standard lamp data sheets (<i>first revision</i>)
1258 : 1987	Specification for bayonet lamp holders (<i>third revision</i>)	(Part 3) : 1977	Dimensions of G-5 and G-13 bi-pin caps (<i>first revision</i>)
1293 : 1988	Specification for plugs and socket-outlets rated voltage up to and including 250 V and rated current up to and including 16 amperes (<i>second revision</i>)	(Part 4) : 1977	Go and no-go gauges for G-5 and G-13 bi-pin caps (<i>first revision</i>)
1534	Specification for ballasts for fluorescent lamps: Part 1 For switch start circuits (<i>second revision</i>)	2667 : 1988	Specification for fittings for rigid steel conduits for electrical wiring (<i>second revision</i>)
(Part 1) : 1977		2675 : 1983	Specification for enclosed distribution fuseboards and cutouts for voltages not exceeding 1 000 V (<i>second revision</i>)
1554	PVC insulated (heavy duty) electric cables:	3287 : 1965	Specification for industrial lighting fittings with plastic reflectors
(Part 1) : 1988	For working voltages upto and including 1 100 V (<i>third revision</i>)	3323 : 1980	Specification for bi-pin lamp holders for tubular fluorescent lamps (<i>first revision</i>)
(Part 2) : 1988	For working voltages from 3.3 kV upto and including 11 kV (<i>second revision</i>)	3324 : 1982	Specification for holders for starters for tubular fluorescent lamps (<i>first revision</i>)
1777 : 1978	Specification for industrial luminaire with metal reflectors (<i>first revision</i>)	3419 : 1989	Specification for fittings for rigid non-metallic conduits (<i>second revision</i>)
2086 : 1993	Specification for carriers and bases used in re-wirable type electric fuses up to 650 V (<i>third revision</i>)	3480 : 1966	Specification for flexible steel conduits for electrical wiring
2148 : 2004	Specification for flameproof enclosures “d” for electrical apparatus for explosive gas atmospheres (<i>third revision</i>)	3528 : 1966	Specification for waterproof electric lighting fittings
2206	Specification for flameproof electric lighting fittings:	3553 : 1966	Specification for watertight electric lighting fittings
(Part 1) : 1984	Well glass and bulkhead types (<i>first revision</i>)	3837 : 1976	Specification for accessories for rigid steel conduits for electrical wiring (<i>first revision</i>)
(Part 2) : 1976	Fittings using glass tubes	3854 : 1997	Specification for switches for domestic and similar purposes (<i>second revision</i>)
(Part 3) : 1989	Fittings using fluorescent lamps and plastic covers	4012 : 1967	Specification for dust-proof electric lighting fittings
(Part 4) : 1987	Portable flame-proof handlamps and approved flexible cables	4013 : 1967	Specification for dust-tight electric lighting fittings

<i>IS No.</i>	<i>Title</i>	<i>IS No.</i>	<i>Title</i>
4160 : 1967	Specification for interlocking switch socket outlet	(Part 5/Sec 5) : 1987	Particular requirements, Section 5 Flood light
4615 : 1968	Specification for switch socket outlets (non-interlocking type)	11037 : 1984	Electronic type fan regulators
4649 : 1968	Specification for adaptors for flexible steel conduits	13010 : 2002	AC watt-hour meters, Class 0.5, 1 and 2 (<i>first revision</i>)
5077 : 1969	Specification for decorative lighting outfits	13779 : 1999	AC static watt-hour meters (Class 1 and 2) (<i>first revision</i>)
6538 : 1971	Specification for three-pin plugs made of resilient material	13947 (Part 3) : 1993	Specification for low-voltage switchgear and controlgear: Part 3 Switches, disconnectors, switch disconnectors and fuse combination units
8030 : 1976	Specification for luminaires for hospitals	14763 : 2000	Conduit for electrical purposes, outside diameters of conduits for electrical installations and threads for conduits and fittings
8828 : 1996	Specification for circuit-breakers for over current protection for household and similar installation (<i>second revision</i>)	14768	Conduit fittings for electrical installations:
9537	Specification for conduits for electrical installations:	(Part 1) : 2000	General requirements
(Part 1) : 1980	General requirements	(Part 2) : 2003	Metal conduit fittings
(Part 2) : 1981	Rigid steel conduits	14772 : 2000	Enclosures for accessories for household and similar fixed electrical installations
(Part 3) : 1983	Rigid plain conduits for insulating materials	14927	Cable trunking and ducting systems for electrical installations
(Part 4) : 1983	Pliable self-recovering conduits for insulating materials	(Part 1) : 2001	General requirements
(Part 5) : 2000	Pliable conduits of insulating materials	(Part 2) : 2001	Cable trunking and ducting systems intended for mounting on walls or ceilings
(Part 6) : 2000	Pliable conduits of metal or composite materials	14930	Conduit systems for electrical installations:
(Part 8) : 2003	Rigid non-threadable conduits of aluminium alloy	(Part 1) : 2001	General requirements
9926 : 1981	Specification for fuse wires used in rewirable type electric fuses up to 650 V	(Part 2) : 2001	Particular requirements for conduit system buried underground
10322	Specification for luminaires:	15368 : 2003	Cable reels for household and similar purposes
(Part 1) : 1982	General requirements		
(Part 2) : 1982	Constructional requirements		
(Part 3) : 1984	Screw and screwless terminations		
(Part 4) : 1984	Methods of tests		
(Part 5/Sec 1) : 1985	Particular requirements, Section 1 General purpose luminaires		
(Part 5/Sec 2) : 1985	Particular requirements, Section 2 Recessed luminaires		
(Part 5/Sec 3) : 1987	Particular requirements, Section 3 Luminaires for road and street lighting		
(Part 5/Sec 4) : 1987	Particular requirements, Section 4 Portable general purpose luminaires		

12. FILLERS, STOPPERS AND PUTTIES

110 : 1983	Specification for ready mixed paint, brushing, grey filler, for enamels, for use over primers (<i>first revision</i>)
419 : 1967	Specification for putty for use on window frames (<i>first revision</i>)
423 : 1961	Specification for plastic wood, for joiner's filler (<i>revised</i>)
3709 : 1966	Specification for mastic cement for bedding of metal windows
7164 : 1973	Specification for stopper

<i>IS No.</i>	<i>Title</i>	<i>IS No.</i>	<i>Title</i>
13184 : 1991	Specification for mastic filler, epoxy based		heavy hydrocarbon products like kerosene, diesel and furnace oil
13. FLOOR COVERING, ROOFING AND OTHER FINISHES		f) Plastic Flooring	
a) Concrete Flooring		3461 : 1980	Specification for PVC asbestos floor tiles (<i>first revision</i>)
1237 : 1980	Specification for cement concrete flooring tiles (<i>first revision</i>)	3462 : 1986	Specification for unbacked flexible PVC flooring (<i>second revision</i>)
13801 : 1993	Specification for chequered cement concrete tiles	3464 : 1986	Methods of test for plastic flooring and wall tiles (<i>second revision</i>)
b) Flooring Compositions		g) Ceramic/Vitreous	
657 : 1982	Specification for materials for use in the manufacture of magnesium oxychloride flooring compositions (<i>second revision</i>)	2333 : 1992	Specification for plaster of Paris for ceramic industry (<i>second revision</i>)
9162 : 1979	Methods of tests for epoxy resin, hardeners and epoxy resin composition for floor topping	4457 : 1982	Specification for ceramic unglazed vitreous acid resisting tile (<i>first revision</i>)
9197 : 1979	Specification for epoxy resin, hardness and epoxy resin compositions for floor topping	13630	Method of test for ceramic tiles:
10132 : 1982	Method of test for materials for use in the preparation of magnesium oxychloride flooring composition	(Part 1) : 1993	Determination of dimensions and surface quality
c) Linoleum Flooring		(Part 2) : 1992	Determination of water absorption
653 : 1992	Specification for linoleum sheets and tiles (<i>third revision</i>)	(Part 3) : 1992	Determination of moisture expansion using boiling water — Unglazed tiles
9704 : 1980	Methods of tests for linoleum sheets and tiles	(Part 4) : 1992	Determination of linear thermal expansion
d) Rubber Flooring		(Part 5) : 1992	Determination of resistance to thermal shock
809 : 1992	Specification for rubber flooring materials for general purposes (<i>second revision</i>)	(Part 6) : 1993	Determination of modulus of rupture
e) Bituminous Flooring		(Part 7) : 1993	Determination of chemical resistance — Unglazed tiles
1195 : 2002	Specification for bitumen mastic for flooring (<i>third revision</i>)	(Part 8) : 1993	Determination of chemical resistance — Glazed tiles
8374 : 1977	Specification for bitumen mastic, anti-static and electrically conducting grade	(Part 9) : 1993	Determination of crazing resistance — Glazed tiles
9510 : 1980	Specification for bitumen mastic acid resisting grade	(Part 10) : 1993	Determination of frost resistance
13026 : 1991	Specification for bitumen mastic for flooring for industries handling LPG and other light hydrocarbon products	(Part 11) : 1993	Determination of resistance to surface abrasion — Glazed tiles
15194 : 2002	Specification for pitch-mastic flooring for industries handling	(Part 12) : 1993	Determination of resistance to deep abrasion — Unglazed tiles
		(Part 13) : 1993	Determination of scratch hardness of surface according to Mohs'
		13711 : 1993	Sampling and basis for acceptance of ceramic tiles
		13753 : 1993	Specification for dust pressed ceramic tiles with water absorption of E > 10% Group (B III)
		13754 : 1993	Specification for dust pressed ceramic tiles with water absorption of 6% < E < 10% Group (B II b)

<i>IS No.</i>	<i>Title</i>	<i>IS No.</i>	<i>Title</i>
13755 : 1993	Specification for dust pressed ceramic tiles with water absorption of 3% < E < 6% Group (B II a)	13317 : 1992	Specification for clay roofing camty tiles, half round and flat tiles
13756 : 1993	Specification for dust pressed ceramic tiles with water absorption of E < 3% Group B I	k) Wall Coverings/Finishing	
h) Other Floorings		1542 : 1992	Specification for sand for plaster (<i>second revision</i>)
4456	Methods of test for chemical resistant mortars:	4456	Methods of test for chemical resistant mortars:
(Part 1) : 1967	Silicate type and resin type	(Part 1) : 1967	Silicate type and resin type
(Part 2) : 1967	Sulphur type	(Part 2) : 1967	Sulphur type
4457 : 1982	Specification for ceramic unglazed vitreous acid resisting tile (<i>first revision</i>)	4832	Specification for chemical resistant mortars:
4832	Specification for chemical resistant mortars:	(Part 1) : 1969	Silicate type
(Part 1) : 1969	Silicate type	(Part 2) : 1969	Resin type
(Part 2) : 1969	Resin type	(Part 3) : 1968	Sulphur type
(Part 3) : 1968	Sulphur type	15418 : 2003	Specification for finished wall papers, wall vinyls and plastic wall coverings in roll form
4860 : 1968	Specification for acid resistant bricks	14. GLASS	
j) Roofing		2553	Specification for safety glass: Part 1 General purpose (<i>third revision</i>)
277 : 1992	Specification for galvanized steel sheets (plain and corrugated (<i>fifth revision</i>))	(Part 1) : 1990	
459 : 1992	Specification for corrugated and semi-corrugated asbestos cement sheets (<i>third revision</i>)	2835 : 1987	Specification for flat transparent sheet glass (<i>third revision</i>)
654 : 1992	Specification for clay roofing tiles, Mangalore pattern (<i>third revision</i>)	3438 : 1994	Specification for silvered glass mirrors for general purposes (<i>second revision</i>)
1464 : 1992	Specification for clay ridge and ceiling tiles (<i>second revision</i>)	5437 : 1994	Specification for figured rolled and wired glass (<i>first revision</i>)
2690	Specification for burnt clay flat terracing tiles:	14900 : 2000	Specification for transparent float glass
(Part 1) : 1993	Machine made (<i>second revision</i>)	15. GYPSUM BASED MATERIALS	
(Part 2) : 1992	Hand-made (<i>second revision</i>)	2095	Specification for gypsum plaster boards:
3951	Specification for hollow clay tiles for floor and roofs:	(Part 1) : 1996	Plain gypsum plaster boards
(Part 1) : 1975	Filler type (<i>first revision</i>)	(Part 2) : 2001	Coated/laminated gypsum plaster boards
(Part 2) : 1975	Structural type (<i>first revision</i>)	(Part 3) : 1996	Reinforced gypsum plaster boards (<i>second revision</i>)
10388 : 1982	Specification for corrugated coir wood wool cement roofing sheets	2542	Methods of test for gypsum plaster, concrete and products:
12583 : 1988	Specification for corrugated bitumen roofing sheets	(Part 1/Sec 1) : 1978	Plaster and concrete, Section 1 Normal consistency of gypsum plaster (<i>first revision</i>)
12866 : 1989	Specification for plastic translucent sheets made from thermosetting polyester resin (glass fibre reinforced)	(Part 1/Sec 2) : 1978	Plaster and concrete, Section 2 Normal consistency of gypsum concrete (<i>first revision</i>)

<i>IS No.</i>	<i>Title</i>	<i>IS No.</i>	<i>Title</i>
(Part 1/Sec 3) : 1978	Plaster and concrete, Section 3 Setting time of plaster and concrete (<i>first revision</i>)	(Part 1) : 1976	Excluding premixed lightweight plaster (<i>first revision</i>)
(Part 1/Sec 4) : 1978	Plaster and concrete, Section 4 Transverse strength of gypsum plaster (<i>first revision</i>)	(Part 2) : 1976	Premixed lightweight plaster (<i>first revision</i>)
(Part 1/Sec 5) : 1978	Plaster and concrete, Section 5 Compressive strength and dry set density of gypsum plaster (<i>first revision</i>)	2849 : 1983	Specification for non-load bearing gypsum partition blocks (solid and hollow types)
(Part 1/Sec 6) : 1978	Plaster and concrete, Section 6 Soundness of gypsum plaster (<i>first revision</i>)	8272 : 1984	Specification for gypsum plaster or use in the manufacture of fibrous plasterboards (<i>first revision</i>)
(Part 1/Sec 7) : 1978	Plaster and concrete, Section 7 Mechanical resistance of gypsum plaster by dropping ball test (<i>first revision</i>)	9498 : 1980	Specification for inorganic aggregates for use in gypsum plaster
(Part 1/Sec 8) : 1978	Plaster and concrete, Section 8 Freedom from coarse particles (<i>first revision</i>)	16. LIGNOCELLULOSIC BUILDING MATERIALS	
(Part 1/Sec 9) : 1978	Plaster and concrete, Section 9 Expansion of plaster (<i>first revision</i>)	a) Timber and Bamboo	
(Part 1/Sec 10) : 1978	Plaster and concrete, Section 10 Sand in set plaster (<i>first revision</i>)	i) <i>Timber Classification</i>	
(Part 1/Sec 11) : 1978	Plaster and concrete, Section 11 Wood fibre content in gypsum plaster (<i>first revision</i>)	399 : 1963	Classification of commercial timbers and their zonal distribution (<i>revised</i>)
(Part 1/Sec 12) : 1978	Plaster and concrete, Section 12 Dry bulk density (<i>first revision</i>)	1150 : 2000	Trade names and abbreviated symbols for timber species (<i>third revision</i>)
(Part 2/Sec 1) : 1981	Gypsum products, Section 1 Measurement of dimensions (<i>first revision</i>)	4970 : 1973	Key for identification of commercial timber (<i>first revision</i>)
(Part 2/Sec 2) : 1981	Gypsum products, Section 2 Determination of mass (<i>first revision</i>)	ii) <i>Timber Conversion and Grading</i>	
(Part 2/Sec 3) : 1981	Gypsum products, Section 3 Determination of mass and thickness of paper surfacing (<i>first revision</i>)	190 : 1991	Specification for coniferous sawn timber (baulks and scantlings) (<i>fourth revision</i>)
(Part 2/Sec 4) : 1981	Gypsum products, Section 4 Transverse strength (<i>first revision</i>)	1326 : 1992	Specification for non-coniferous sawn timber (baulks and scantlings) (<i>second revision</i>)
(Part 2/Sec 5) : 1981	Gypsum products, Section 5 Compressive strength (<i>first revision</i>)	1331 : 1971	Specification for cut sizes of timber (<i>second revision</i>)
(Part 2/Sec 6) : 1981	Gypsum products, Section 6 Water absorption (<i>first revision</i>)	3337 : 1978	Specification for ballies for general purposes (<i>first revision</i>)
(Part 2/Sec 7) : 1981	Gypsum products: Section 7 Moisture content (<i>first revision</i>)	5966 : 1993	Specification for non-coniferous timber in converted form for general purpose (<i>first revision</i>)
(Part 2/Sec 8) : 1981	Gypsum products, Section 8 Nail retention of precast reinforced gypsum slabs (<i>first revision</i>)	14960 : 2001	Specification for preservative treated and seasoned sawn timber from rubberwood (<i>Hevea brasiliensis</i>)
2547	Specification for gypsum building plaster:	iii) <i>Timber Testing</i>	
		1708	Methods of testing small clear specimens of timber:
		(Part 1) : 1986	Determination of moisture content (<i>second revision</i>)

<i>IS No.</i>	<i>Title</i>	<i>IS No.</i>	<i>Title</i>
(Part 2) : 1986	Determination of specific gravity (<i>second revision</i>)	(Part 1) : 1991	Determination of copper, arsenic, chromium, zinc, boron, creosote and fuel oil (<i>first revision</i>)
(Part 3) : 1986	Determination of volumetric shrinkage (<i>second revision</i>)	(Part 2) : 1991	Determination of copper (in copper organic preservative salt) and pentachlorophenol (<i>first revision</i>)
(Part 4) : 1986	Determination of radial and tangential shrinkage and fibre saturation point (<i>second revision</i>)	4907 : 1968	Method of testing timber connectors
(Part 5) : 1986	Determination of static bending strength (<i>second revision</i>)	8292 : 1992	Methods for evaluation of working quality of timber under different wood operations — Method of test (<i>first revision</i>)
(Part 6) : 1986	Determination of static bending strength under two point loading (<i>second revision</i>)	8720 : 1978	Methods of sampling of timber scantlings from depots and their conversion for testing
(Part 7) : 1986	Determination of impact bending strength (<i>second revision</i>)	8745 : 1994	Methods of presentation of data of physical and mechanical properties of timber (<i>first revision</i>)
(Part 8) : 1986	Determination of compressive strength parallel to grain (<i>second revision</i>)	10420 : 1982	Method of determination of sound absorption coefficient of timber by standing wave method
(Part 9) : 1986	Determination of compressive strength perpendicular to grain (<i>second revision</i>)	10754 : 1983	Method of determination of thermal conductivity of timber
(Part 10) : 1986	Determination of hardness under static indentation (<i>second revision</i>)	11215 : 1991	Methods for determination of moisture content of timber and timber products (<i>first revision</i>)
(Part 11) : 1986	Determination of shear strength parallel to grain (<i>second revision</i>)	13621 : 1993	Method of test for determination of dielectric constant of wood under microwave frequencies
(Part 12) : 1986	Determination of tensile strength parallel to grain (<i>second revision</i>)		
(Part 13) : 1986	Determination of tensile strength perpendicular to grain (<i>second revision</i>)		
(Part 14) : 1986	Determination of cleavage strength parallel to grain (<i>second revision</i>)	iv) <i>Structural Timber and Test</i>	
(Part 15) : 1986	Determination of nail and screw holding power (<i>second revision</i>)	3629 : 1986	Specification for structural timber in building (<i>first revision</i>)
(Part 16) : 1986	Determination of brittleness by izod impact (<i>second revision</i>)	4891 : 1988	Specification for preferred cut sizes of structural timber (<i>first revision</i>)
(Part 17) : 1986	Determination of brittleness by Charpy impact (<i>second revision</i>)	4924	Method of test for nail jointed timber trusses:
(Part 18) : 1986	Determination of torsional strength (<i>second revision</i>)	(Part 1) : 1968	Destructive test
		(Part 2) : 1968	Proof test
		v) <i>Logs</i>	
1900 : 1974	Method of testing wood poles (<i>first revision</i>)	3364	Method of measurement and evaluation of defects in timber:
2408 : 1963	Methods of static tests of timbers in structural sizes	(Part 1) : 1976	Logs (<i>first revision</i>)
2455 : 1990	Method of sampling of model trees and logs for timber testing and their conversion (<i>second revision</i>)	(Part 2) : 1976	Converted timber (<i>first revision</i>)
2753	Methods for estimation of preservatives in treated timber and treating solutions:	4895 : 1985	Specification for teak logs (<i>first revision</i>)
		5246 : 2000	Specification for coniferous logs (<i>first revision</i>)
		7308 : 1999	Specification for non-coniferous logs (<i>first revision</i>)

<i>IS No.</i>	<i>Title</i>	<i>IS No.</i>	<i>Title</i>
vi) <i>Bamboo</i>		(Part 20) : 1983	Acidity and alkalinity resistance test (<i>second revision</i>)
6874 : 1973	Method of tests for round bamboos	4990 : 1993	Specification for plywood for concrete shuttering work (<i>second revision</i>)
8242 : 1976	Methods of tests for split bamboos	5509 : 2000	Specification for fire retardant plywood (<i>second revision</i>)
b) Reconstituted Products		5539 : 1969	Specification for preservative treated plywood
i) <i>Plywood</i>		7316 : 1974	Specification for decorative plywood using plurality of veneers for decorative faces
303 : 1989	Specification for plywood for general purposes (<i>third revision</i>)	10701 : 1983	Specification for structural plywood
1328 : 1996	Specification for veneered decorative plywood (<i>third revision</i>)	13957 : 1994	Specification for metal faced plywood
1734	Method of test for plywood:	ii) <i>Blockboards, Particle Boards and Fibre Boards</i>	
(Part 1) : 1983	Determination of density and moisture content (<i>second revision</i>)	1658 : 1977	Specification for fibre hardboards (<i>second revision</i>)
(Part 2) : 1983	Determination of resistance of dry heat (<i>second revision</i>)	1659 : 1990	Specification for block boards (<i>third revision</i>)
(Part 3) : 1983	Determination of fire resistance (<i>second revision</i>)	2380	Methods of test for wood particle boards and boards from other lignocellulosic materials:
(Part 4) : 1983	Determination of glue shear strength (<i>second revision</i>)	(Part 1) : 1977	Preparation and conditioning of test specimens (<i>first revision</i>)
(Part 5) : 1983	Test for adhesion of plies (<i>second revision</i>)	(Part 2) : 1977	Accuracy of dimensions of boards (<i>first revision</i>)
(Part 6) : 1983	Determination of water resistance (<i>second revision</i>)	(Part 3) : 1977	Determination of moisture content and density (<i>first revision</i>)
(Part 7) : 1983	Mycological test (<i>second revision</i>)	(Part 4) : 1977	Determination of static bending strength (<i>first revision</i>)
(Part 8) : 1983	Determination of pH value (<i>second revision</i>)	(Part 5) : 1977	Determination of tensile strength perpendicular to surface (<i>first revision</i>)
(Part 9) : 1983	Determination of tensile strength (<i>second revision</i>)	(Part 6) : 1977	Determination of tensile strength parallel to surface (<i>first revision</i>)
(Part 10) : 1983	Determination of compressive strength (<i>second revision</i>)	(Part 7) : 1977	Determination of compression — Perpendicular to plane of the board (<i>first revision</i>)
(Part 11) : 1983	Determination of static bending strength (<i>second revision</i>)	(Part 8) : 1977	Compression parallel to surface test (<i>first revision</i>)
(Part 12) : 1983	Determination of scarf joint strength (<i>second revision</i>)	(Part 9) : 1977	Determination of resistance to shear in plane of the board (<i>first revision</i>)
(Part 13) : 1983	Determination of panel shear strength (<i>second revision</i>)	(Part 10) : 1977	Falling hammer impact test (<i>first revision</i>)
(Part 14) : 1983	Determination of plate shear strength (<i>second revision</i>)	(Part 11) : 1977	Surface hardness (<i>first revision</i>)
(Part 15) : 1983	Central loading of plate test (<i>second revision</i>)	(Part 12) : 1977	Central loading of plate test (<i>first revision</i>)
(Part 16) : 1983	Vibration of plywood plate test (<i>second revision</i>)		
(Part 17) : 1983	Long time loading test of plywood strips (<i>second revision</i>)		
(Part 18) : 1983	Impact resistance test on the surface of plywood (<i>second revision</i>)		
(Part 19) : 1983	Determination of nails and screws holding power (<i>second revision</i>)		

<i>IS No.</i>	<i>Title</i>	<i>IS No.</i>	<i>Title</i>
(Part 13) : 1977	Long time loading bending test (<i>first revision</i>)	iii) <i>Wood-Based Laminates</i>	
(Part 14) : 1977	Screw and nail withdrawal test (<i>first revision</i>)	3513 (Part 3) : 1989	Specification for resin treated compressed wood laminates (compregs): Part 3 For general purposes (<i>first revision</i>)
(Part 15) : 1977	Lateral nail resistance (<i>first revision</i>)	3513 (Part 4) : 1966	Specification for high and medium density wood laminates (compreg): Part 4 Sampling and tests
(Part 16) : 1977	Determination of water absorption (<i>first revision</i>)	7638 : 1998	Methods of sampling for wood/ lignocellulosic based panel products
(Part 17) : 1977	Determination of swelling in water (<i>first revision</i>)	9307	Methods of tests for wood-based structural sandwich construction:
(Part 18) : 1977	Determination of mass and dimensional changes caused by moisture changes (<i>first revision</i>)	(Part 1) : 1979	Flexure test
(Part 19) : 1977	Durability cyclic test for interior use (<i>first revision</i>)	(Part 2) : 1979	Edgewise compression test
(Part 20) : 1977	Accelerated weathering cyclic test for exterior use (<i>first revision</i>)	(Part 3) : 1979	Flatwise compression test
(Part 21) : 1977	Planeness test under uniform moisture content (<i>first revision</i>)	(Part 4) : 1979	Shear test
(Part 22) : 1981	Determination of surface glueability test	(Part 5) : 1979	Flatwise tension test
(Part 23) : 1981	Vibration test for particle boards	(Part 6) : 1979	Flexure creep test
3087 : 1985	Specification for wood particle boards (medium density) for general purposes (<i>first revision</i>)	(Part 7) : 1979	Cantilever vibration test
3097 : 1980	Specification for veneered particle boards (<i>first revision</i>)	(Part 8) : 1979	Weathering test
3129 : 1985	Specification for low density particle board (<i>first revision</i>)	14315 : 1995	Specification for commercial veneers
3308 : 1981	Specification for wood wool building slabs (<i>first revision</i>)	14616 : 1999	Specification for laminated veneer lumber
3348 : 1965	Specification for fibre insulation boards	iv) <i>Bamboo and Coir Board Products</i>	
3478 : 1966	Specification for high density wood particle boards	13958 : 1994	Specification for bamboo mat board for general purposes
12406 : 2003	Specification for medium density fibreboards for general purposes (<i>first revision</i>)	14588 : 1999	Specification for bamboo mat veneer composite for general purposes
12823 : 1990	Specification for prelaminated particle boards	14842 : 2000	Specification for coir veneer board for general purposes
13745 : 1993	Method for determination of formaldehyde content in particle board by extraction method called perforator method	15476 : 2004	Specification for bamboo and corrugated sheets
14276 : 1995	Specification for cement bonded particle boards	v) <i>Adhesives</i>	
14587 : 1998	Specification for prelaminated medium density fibre board	848 : 1974	Specification for synthetic resin adhesives for plywood (phenolic and aminoplastic) (<i>first revision</i>)
		849 : 1994	Specification for cold setting case in glue for wood (<i>first revision</i>)
		851 : 1978	Specification for synthetic resin adhesives for construction work (non-structural) in wood (<i>first revision</i>)
		852 : 1994	Specification for animal glue for general wood-working purposes (<i>second revision</i>)

<i>IS No.</i>	<i>Title</i>	<i>IS No.</i>	<i>Title</i>
1508 : 1972	Specification for extenders for use in synthetic resin adhesives (urea-formaldehyde) for plywood (<i>first revision</i>)	(Part 1/Sec 7) : 1987	Test on liquid paints (general and physical), Section 7 Mass per 10 litres (<i>third revision</i>)
4835 : 1979	Specification for polyvinyl acetate dispersion-based adhesives for wood (<i>first revision</i>)	(Part 2/Sec 1) : 1988	Test on liquid paints (chemical examination), Section 1 Water content (<i>third revision</i>)
9188 : 1979	Performance requirements for adhesive for structural laminated wood products for use under exterior exposure condition	(Part 2/Sec 2) : 1986	Test on liquid paints (chemical examination), Section 2 Volatile matter (<i>third revision</i>)
17. PAINTS AND ALLIED PRODUCTS		(Part 3/Sec 1) : 1986	Tests on paint film formation, Section 1 Drying time (<i>third revision</i>)
a) Water Based Paints and Pigments		(Part 3/Sec 2) : 1989	Tests on paint film formation, Section 2 Film thickness (<i>third revision</i>)
427 : 1965	Specification for distemper, dry, colour as required (<i>revised</i>)	(Part 3/Sec 4) : 1987	Tests on paint film formation, Section 4 Finish (<i>third revision</i>)
428 : 2000	Specification for distemper, washable (<i>second revision</i>)	(Part 3/Sec 5) : 1987	Tests on paint film formation, Section 5 Fineness of grind (<i>third revision</i>)
5410 : 1992	Specification for cement paint, colour as required (<i>first revision</i>)	(Part 4/Sec 1) : 1988	Optical test, Section 1 Opacity (<i>third revision</i>)
5411	Specification for plastic emulsion paint:	(Part 4/Sec 2) : 1989	Optical test, Section 2 Colour (<i>third revision</i>)
(Part 1) : 1974	For interior use (<i>first revision</i>)	(Part 4/Sec 3) : 1988	Optical test, Section 3 Light fastness test (<i>third revision</i>)
(Part 2) : 1972	For exterior use	(Part 4/Sec 4) : 1986	Optical test, Section 4 Gloss (<i>third revision</i>)
b) Ready Mixed Paints, Enamels and Powder Coatings		(Part 5/Sec 1) : 1988	Mechanical test on paint films, Section 1 Hardness tests (<i>third revision</i>)
101	Methods of sampling and test for paints, varnishes and related products:	(Part 5/Sec 2) : 1988	Mechanical test on paint films, Section 2 Flexibility and adhesion (<i>third revision</i>)
(Part 1/Sec 1) : 1986	Test on liquid paints (general and physical), Section 1 Sampling (<i>third revision</i>)	(Part 5/Sec 3) : 1986	Mechanical test on paint films, Section 3 Impact resistance (<i>fourth revision</i>)
(Part 1/Sec 2) : 1987	Test on liquid paints (general and physical), Section 2 Preliminary examination and preparation of samples for testing (<i>third revision</i>)	(Part 5/Sec 4) : 1986	Mechanical test on paint films, Section 4 Print free test (<i>third revision</i>)
(Part 1/Sec 3) : 1986	Test on liquid paints (general and physical), Section 3 Preparation of panels (<i>third revision</i>)	(Part 6/Sec 1) : 1988	Durability tests, Section 1 Resistance to humidity under conditions of condensation (<i>third revision</i>)
(Part 1/Sec 4) : 1987	Test on liquid paints (general and physical), Section 4 Brushing test (<i>third revision</i>)	(Part 6/Sec 2) : 1989	Durability tests, Section 2 Keeping properties (<i>third revision</i>)
(Part 1/Sec 5) : 1989	Test on liquid paints (general and physical), Section 5 Consistency (<i>third revision</i>)	(Part 6/Sec 3) : 1990	Durability tests, Section 3 Moisture vapour permeability (<i>third revision</i>)
(Part 1/Sec 6) : 1987	Test on liquid paints (general and physical), Section 6 Flash point (<i>third revision</i>)		

<i>IS No.</i>	<i>Title</i>	<i>IS No.</i>	<i>Title</i>
(Part 6/Sec 4) : 1991	Durability tests, Section 4 Degradation of coatings (pictorial aids for evaluation)	133 : 1993	Specification for enamel, interior (a) undercoating, (b) finishing (<i>third revision</i>)
(Part 6/Sec 5) : 1997	Durability tests, Section 5 Accelerated weathering test (<i>third revision</i>)	137 : 1965	Specification for ready mixed paint, brushing, matt or egg-shell flat, finishing, interior, to Indian Standard colour, as required (<i>revised</i>)
(Part 7/Sec 1) : 1989	Environmental tests on paint films, Section 1 Resistance to water (<i>third revision</i>)	158 : 1981	Specification for ready mixed paint, brushing, bituminous, black, lead-free, acid, alkali, and heat resisting (<i>third revision</i>)
(Part 7/Sec 2) : 1990	Environmental tests on paint films, Section 2 Resistance to liquids (<i>third revision</i>)	168 : 1993	Specification for ready mixed paint, air-drying semi-glossy/matt, for general purposes (<i>third revision</i>)
(Part 7/Sec 3) : 1990	Environmental tests on paint films, Section 3 Resistance to heat (<i>third revision</i>)	341 : 1973	Specification for black Japan, Types A, B and C (<i>first revision</i>)
(Part 7/Sec 4) : 1990	Environmental tests on paint films, Section 4 Resistance to bleeding of pigments (<i>third revision</i>)	2074 : 1992	Specification for ready mixed paint, air drying red oxide-zinc chrome, priming (<i>second revision</i>)
(Part 8/Sec 1) : 1989	Tests for pigments and other solids, Section 1 Residue on sieve (<i>third revision</i>)	2075 : 2000	Specification for ready mixed paint, stoving, red oxide-zinc chrome, priming (<i>second revision</i>)
(Part 8/Sec 2) : 1990	Tests for pigments and other solids, Section 2 Pigments and non- volatile matter (<i>third revision</i>)	2339 : 1963	Specification for aluminium paint for general purposes, in dual container
(Part 8/Sec 3) : 1993	Tests for pigments and other solids, Section 3 Ash content	2932 : 2003	Specification for enamel, synthetic, exterior, (a) undercoating, (b) finishing (<i>third revision</i>)
(Part 8/Sec 4) : 1993	Tests for pigments and other solids, Section 4 Phthalic anhydride	2933 : 1975	Specification for enamel, exterior, (a) undercoating, (b) finishing (<i>first revision</i>)
(Part 8/Sec 5) : 1993	Tests for pigments and other solids, Section 5 Lead restriction test (<i>third revision</i>)	3536 : 1999	Specification for ready mixed paint, brushing, wood primer (<i>first revision</i>)
(Part 8/Sec 6) : 1993	Tests for pigments and other solids, Section 6 Volume solids	3537 : 1966	Specification for ready mixed paint, finishing, interior for general purposes, to Indian Standard colours No. 101, 216, 217, 219, 275, 281, 352, 353, 358 to 361, 363, 364, 388, 410, 442, 444, 628, 631, 632, 634, 693, 697, white and black
(Part 9/Sec 1) : 1993	Tests for lacquers and varnish, Section 1 Acid value	3539 : 1966	Specification for ready mixed paint, undercoating, for use under oil finishes, to Indian Standard colours, as required
(Part 9/Sec 2) : 1993	Tests for lacquers and varnish, Section 2 Rosin test	3585 : 1966	Specification for ready mixed paint, aluminium, brushing, priming, water resistant, for wood work
104 : 1979	Specification for ready mixed paint, brushing, zinc chrome, priming (<i>second revision</i>)		
109 : 1968	Specification for ready mixed paint, brushing, priming, plaster to Indian Standard colours No. 361 and 631 (<i>first revision</i>)		
123 : 1962	Specification for ready mixed paint, brushing, finishing, semi- gloss, for general purposes, to Indian Standard colours No. 445, 446, 448, 449, 451 and 473; and red oxide (colour unspecified) (<i>revised</i>)		

<i>IS No.</i>	<i>Title</i>	<i>IS No.</i>	<i>Title</i>
3678 : 1966	Specification for ready mixed paint, thick white, for lettering	18. POLYMERS, PLASTICS AND GEOSYNTHETICS/GEOTEXTILES	
8662 : 1993	Specification for enamel, synthetic, exterior, (a) undercoating, (b) finishing, for railway coaches (<i>first revision</i>)	1998 : 1962	Methods of test for thermosetting synthetic resin bonded laminated sheets
9862 : 1981	Specification for ready mixed paint, brushing, bituminous black lead free, acid, alkali, water and chlorine resisting	2036 : 1995	Specification for phenolic laminated sheets (<i>second revision</i>)
11883 : 1986	Specification for ready mixed paint, brushing, red oxide, priming for metals	2046 : 1995	Specification for decorative thermosetting synthetics resin bonded laminated sheets (<i>second revision</i>)
13183 : 1991	Specification for aluminium paints, heat resistant	2076 : 1981	Specification for unsupported flexible vinyl film and sheeting (<i>first revision</i>)
13213 : 1991	Specification for polyurethane full gloss enamel (two pack)	2508 : 1984	Specification for low density polyethylene films (<i>second revision</i>)
13607 : 1992	Specification for ready mixed paint, finishing, general purposes, synthetic	6307 : 1971	Specification for rigid PVC sheets
13871 : 1993	Specification for powder coatings	9766 : 1992	Specification for flexible PVC compound (<i>first revision</i>)
c) Thinners and Solvents		10889 : 1984	Specification for high density polyethylene films
82 : 1992	Methods of sampling and test for thinners and solvents for paints (<i>first revision</i>)	12830 : 1989	Specification for rubber based adhesives for fixing PVC tiles to cement
324 : 1959	Specification for ordinary denatured spirit (<i>revised</i>)	13162 (Part 2) : 1991	Methods of test for geotextiles: Determination of resistance to exposure of ultra-violet light and water (Xenon arc type apparatus)
533 : 1998	Specification for gum spirit of turpentine (oil of turpentine) (<i>second revision</i>)	(Part 3) : 1992	Determination of thickness at specified pressure
14314 : 1995	Specification for thinner general purposes for synthetic paints and varnishes	(Part 4) : 1992	Determination of puncture resistance by falling cone method
d) Varnishes and Lacquers		(Part 5) : 1992	Determination of tensile properties using a wide width strip
337 : 1975	Specification for varnish, finishing, interior (<i>first revision</i>)	13262 : 1992	Specification for pressure sensitive adhesive tapes with plastic base
347 : 1975	Specification for varnish, shellac, for general purposes (<i>first revision</i>)	13325 : 1992	Method of test for the determination to tensile properties of extruded polymer geogrids using the wide strip
348 : 1968	Specification for French polish (<i>first revision</i>)	13326 (Part 1) : 1992	Method of test for the evaluation of interface friction between geosynthetics and soil: Part 1 Modified direct shear technique
524 : 1983	Specification for varnish, finishing, exterior, synthetic (<i>second revision</i>)	14182 : 1994	Specification for solvent cement for use with unplasticized polyvinylchloride plastic pipe and fittings
525 : 1968	Specification for varnish, finishing, exterior and general purposes (<i>first revision</i>)		
642 : 1963	Specification for varnish medium for aluminium paint (<i>revised</i>)		

<i>IS No.</i>	<i>Title</i>	<i>IS No.</i>	<i>Title</i>
14293 : 1995	Method of test for trapezoid tearing — Geotextiles	5219 (Part 1) : 1969	Specification for cast copper alloy traps: Part 1 'P' and 'S' traps
14294 : 1995	Method of determination of apparent opening size by dry sieving technique — Geotextiles	5455 : 1969	Specification for cast-iron steps for manholes
14324 : 1995	Method of test for determination of water permeability-permittivity — Geotextiles	6411 : 1985	Specification for gel-coated glass fibre reinforced polyester resin bath tubs (<i>first revision</i>)
14443 : 1997	Specification for polycarbonate sheets	8718 : 1978	Specification for vitreous enamelled steel kitchen sinks
14643 : 1999	Specification for unsintered polytetrafluoroethylene (PTFE) tape for thread sealing applications	8727 : 1978	Specification for vitreous enamelled steel wash basins
14706 : 1999	Sampling and preparation of test specimen of geotextiles	9140 : 1996	Method of sampling of vitreous and fire clay sanitary appliances (<i>second revision</i>)
14714 : 1999	Determination of abrasion resistance of geotextiles	12701 : 1996	Specification for rotational moulded polyethylene water storage tanks (<i>first revision</i>)
14715 : 2000	Specification for woven jute geotextiles	13983 : 1994	Specification for stainless steel sinks for domestic purposes
14716 : 1999	Determination of mass per unit area of geotextiles	14399	Hot press moulded thermosetting glass fibre reinforced (GRP) sectional water storage tanks:
14739 : 1999	Methods for determination of creep of geotextiles	(Part 1) : 1996	Specification for panels
14753 : 1999	Specification for poly (methyl) methacrylate (PMMA) (Acrylic) sheets	(Part 2) : 1996	Guidelines for assembly, installation and testing
14986 : 2001	Jute geo-grid for rain water erosion control in road and railway embankments and hill slopes	b) Pipes and Fittings Excluding Valves	
15060 : 2001	Tensile test for joints/seams by wide width method of geotextiles	i) <i>Brass and Copper Pipes and Fittings</i>	
19. SANITARY APPLIANCES AND WATER FITTINGS		407 : 1981	Specification for brass tubes for general purposes (<i>third revision</i>)
a) General		2501 : 1995	Specification for solid drawn copper tubes for general engineering purposes (<i>third revision</i>)
775 : 1970	Specification for cast iron brackets and supports for wash basins and sinks (<i>second revision</i>)	ii) <i>Cast Iron Pipes and Fittings</i>	
782 : 1978	Specification for caulking lead (<i>third revision</i>)	1536 : 2001	Specification for centrifugally cast (spun) iron pressure pipes for water, gas and sewage (<i>fourth revision</i>)
804 : 1967	Specification for rectangular pressed steel tanks (<i>first revision</i>)	1537 : 1976	Specification for vertically cast iron pressure pipes for water, gas and sewage (<i>first revision</i>)
1700 : 1973	Specification for drinking fountains (<i>first revision</i>)	1538 : 1993	Specification for cast iron fittings for pressure pipes for water, gas and sewage (<i>third revision</i>)
2963 : 1979	Specification for copper alloy waste fittings for wash-basins and sinks (<i>first revision</i>)	1729 : 2002	Specification for sand cast iron spigot and socket soil, waste and ventilating pipes, fittings and accessories (<i>second revision</i>)
3489 : 1985	Specification for enamelled steel bath tubs (<i>first revision</i>)		

<i>IS No.</i>	<i>Title</i>	<i>IS No.</i>	<i>Title</i>
1879 : 1987	Specification for malleable cast iron pipe fittings (<i>second revision</i>)	12988 : 1991	Rubber sealing rings for CID joints for light duty AC pipes — Dimensional requirements
3486 : 1966	Specification for cast iron spigot and socket drain pipes	13382 : 1992	Cast iron specials for mechanical and push on flexible joints for pressure pipelines for water, gas and sewage
3989 : 1984	Specification for centrifugally cast (spun) iron spigot and socket soil, waste and ventilating pipes, fittings and accessories (<i>second revision</i>)		
5531 : 1988	Specification for cast iron specials for asbestos cement pressure pipes for water, gas and sewage (<i>second revision</i>)	iii) <i>Lead Pipes and Fittings</i>	
6163 : 1978	Specification for centrifugally cast (spun) iron low pressure pipes for water, gas and sewage (<i>first revision</i>)	404 (Part 1) : 1993	Specification for lead pipes: Part 1 For other than chemical purpose (<i>third revision</i>)
6418 : 1971	Specification for cast iron and malleable cast iron flanges for general engineering purposes	iv) <i>Fibre Pipes and Fittings</i>	
7181 : 1986	Specification for horizontally cast iron double flanged pipes for water, gas and sewage (<i>first revision</i>)	11925 : 1986	Specification for pitch-impregnated fibre pipes and fittings for drainage purposes
8329 : 2000	Specification for centrifugally cast (spun) ductile iron pressure pipes for water, gas and sewage (<i>third revision</i>)	v) <i>Plastic Pipes and Fittings</i>	
8794 : 1988	Specification for cast iron detachable joints for use with asbestos cement pressure pipes (<i>first revision</i>)	3076 : 1985	Specification for low density polyethylene pipes for potable water supplies (<i>second revision</i>)
9523 : 1980	Specification for ductile iron fittings for pressure pipes for water, gas and sewage	4984 : 1995	Specification for high density polyethylene pipes for water supply (<i>fourth revision</i>)
10292 : 1988	Dimensional requirements for rubber sealing rings for CID joints in asbestos cement piping (<i>first revision</i>)	4985 : 2000	Specification for unplasticized PVC pipes for potable water supplies (<i>third revision</i>)
10299 : 1982	Cast iron saddle pieces for service connection from asbestos cement pressure pipes	7834	Specification for injection moulded PVC socket fittings with solvent cement joints for water supplies:
11606 : 1986	Methods of sampling cast iron pipes and fittings	(Part 1) : 1987	General requirements (<i>first revision</i>)
12820 : 1989	Dimensional requirements of rubber gaskets for mechanical joints and push on joints for use with cast iron pipes and fittings for carrying water, gas and sewage	(Part 2) : 1987	Specific requirements for 45° elbows (<i>first revision</i>)
12987 : 1991	Cast iron detachable joints for use with asbestos cement pressure pipes (light duty)	(Part 3) : 1987	Specific requirements for 90° elbows (<i>first revision</i>)
		(Part 4) : 1987	Specific requirements for 90° tees (<i>first revision</i>)
		(Part 5) : 1987	Specific requirements for 45° tees (<i>first revision</i>)
		(Part 6) : 1987	Specific requirements for sockets (<i>first revision</i>)
		(Part 7) : 1987	Specific requirements for unions (<i>first revision</i>)
		(Part 8) : 1987	Specific requirements for caps (<i>first revision</i>)
		8008	Specification for injection moulded high density polyethylene (HDPE) fittings for potable water supplies:
		(Part 1) : 2003	General requirements

<i>IS No.</i>	<i>Title</i>	<i>IS No.</i>	<i>Title</i>
(Part 2) : 2003	Specific requirements for 90° bends (<i>first revision</i>)	12235	Methods of test for unplasticized PVC pipes for potable water supplies:
(Part 3) : 2003	Specific requirements for 90° tees	(Part 1) : 1986	Method of measurement of outside diameter
(Part 4) : 2003	Specific requirements for reducers	(Part 2) : 1986	Measurement of wall thickness
(Part 5) : 2003	Specific requirements for ferrule reducers (<i>first revision</i>)	(Part 3) : 1986	Test for opacity
(Part 6) : 2003	Specific requirements for pipe ends	(Part 4) : 1986	Determining the detrimental effect on the composition of water
(Part 7) : 2003	Specific requirements for sandwich flanges	(Part 5) : 1986	Reversion test
(Part 8) : 2003	Specific requirements for reducing tests	(Part 6) : 1986	Stress relief test
(Part 9) : 2003	Specific requirements for end caps (<i>first revision</i>)	(Part 7) : 1986	Test for resistance to sulphuric acid
8360	Specification for fabricated high density polyethylene (HDPE) fittings for potable water supplies:	(Part 8) : 1986	Internal hydrostatic pressure test
(Part 1) : 1977	General requirements	(Part 9) : 1986	Impact strength test
(Part 2) : 1977	Specific requirements for 90° tees	(Part 10) : 1986	Method for determination of organotin as tin aqueous solution
(Part 3) : 1977	Specific requirements for 90° bends	(Part 11) : 1986	Extractability of cadmium and mercury occurring as impurities
10124	Specification for fabricated PVC fittings for potable water supplies:	12709 : 1994	Specification for glass-fibre reinforced plastic (GRP) pipes joints and fittings for use for potable water supply (<i>first revision</i>)
(Part 1) : 1988	General requirements (<i>first revision</i>)	12818 : 1992	Specification for unplasticized PVC screen and casing pipes for bore/tubewell (<i>first revision</i>)
(Part 2) : 1988	Specific requirements for sockets (<i>first revision</i>)	13592 : 1992	Specification for UPVC pipes for soil and waste discharge systems inside buildings including ventilation and rainwater system
(Part 3) : 1988	Specific requirements of straight reducers (<i>first revision</i>)	14333 : 1996	Specification for high density polyethylene pipes for sewerage
(Part 4) : 1988	Specific requirements for caps (<i>first revision</i>)	14402 : 1996	Specification for GRP pipes, joints and fittings for use for sewerage, industrial waste and water (other than potable)
(Part 5) : 1988	Specific requirements for equal tees (<i>first revision</i>)	14735 : 1999	Specification for unplasticized polyvinyl chloride (UPVC) injection moulded fittings for soil and waste discharge system for inside buildings including ventilation and rain water system
(Part 6) : 1988	Specific requirements for flanged tail piece with metallic flanges (<i>first revision</i>)	14885 : 2001	Specification for polyethylene pipe for supply of gaseous fuel
(Part 7) : 1988	Specific requirements for threaded adaptors (<i>first revision</i>)	15225 : 2002	Specification for chlorinated polyvinyl chloride compounds used for pipes and fittings
(Part 8) : 1988	Specific requirements for 90° bends (<i>first revision</i>)	15328 : 2003	Specification for unplasticized non-pressure polyvinyl chloride (PVC-U) pipes for use in underground drainage and sewerage system
(Part 9) : 1988	Specific requirements for 60° bends (<i>first revision</i>)		
(Part 10) : 1988	Specific requirements for 45° bends (<i>first revision</i>)		
(Part 11) : 1988	Specific requirements for 30° bends (<i>first revision</i>)		
(Part 12) : 1988	Specific requirements for 22½° bends (<i>first revision</i>)		
(Part 13) : 1988	Specific requirements for 11¼° bends (<i>first revision</i>)		

<i>IS No.</i>	<i>Title</i>	<i>IS No.</i>	<i>Title</i>
vi) <i>Steel Tubes, Pipes and Fittings</i>		(Part 4) : 1979	Specific requirements of post mortom slabs (<i>second revision</i>)
1239	Mild steel tubes, tubular and other wrought steel fittings:	(Part 5) : 1979	Specific requirements of shower trays (<i>second revision</i>)
(Part 1) : 1990	Mild steel tubes (<i>fifth revision</i>)	(Part 6) : 1979	Specific requirements of bed-pan sinks (<i>second revision</i>)
(Part 2) : 1992	Mild steel tubular and other wrought steel pipe fittings (<i>third revision</i>)	(Part 7) : 1981	Specific requirements of slop sinks (<i>second revision</i>)
3589 : 1991	Specification for seamless or electrically welded steel pipes for water, gas and sewage (168.3 to 2 032 mm outside size) (<i>second revision</i>)	772 : 1973	Specification for general requirements of enamelled cast iron sanitary appliances (<i>second revision</i>)
4270 : 1992	Steel tubes used for water wells (<i>second revision</i>)	773 : 1988	Specification for enamelled cast iron water-closets railway stock type (<i>fourth revision</i>)
5504 : 1997	Specification for spiral welded pipes (<i>first revision</i>)	774 : 1984	Specification for flushing cisterns for water-closets and urinals (other than plastic cisterns) (<i>fourth revision</i>)
6286 : 1979	Seamless and welded steel pipe for sub-zero temperature service	1726 : 1991	Specification for cast iron manhole covers and frames (<i>third revision</i>)
6392 : 1971	Steel pipe flanges	2326 : 1987	Specification for automatic flushing cisterns for urinals (<i>second revision</i>)
vii) <i>Stoneware Pipes and Fittings</i>		2548	Specification for plastic seats and covers for water-closets:
651 : 1992	Specification for salt-glazed stoneware pipes and fittings (<i>fifth revision</i>)	(Part 1) : 1996	Thermoset seats and covers (<i>fifth revision</i>)
3006 : 1979	Specification for chemically resistant glazed stoneware pipes and fittings (<i>first revision</i>)	(Part 2) : 1996	Thermoplastic seats and covers (<i>fifth revision</i>)
viii) <i>Asbestos Cement Pipes</i>		2556	Specification for vitreous sanitary appliances (vitreous china):
[See 8 (a) (ii) under the category 'Composite Matrix Products']		(Part 1) : 1994	General requirements (<i>third revision</i>)
ix) <i>Concrete Pipes and Pipes Lined/Coated with Concrete or Mortar</i>		(Part 2) : 1994	Specific requirements of wash-down water-closets (<i>fourth revision</i>)
[See 8 (a) (iv) under the category 'Composite Matrix Products']		(Part 3) : 1994	Specific requirements of squatting pans (<i>fourth revision</i>)
c) Kitchen and Sanitary Appliances			
771	Specification for glazed fire clay sanitary appliances:	(Part 4) : 1994	Specific requirements of wash basins (<i>third revision</i>)
(Part 1) : 1979	General requirements (<i>second revision</i>)	(Part 5) : 1994	Specific requirements of laboratory sinks (<i>third revision</i>)
(Part 2) : 1985	Specific requirements of kitchen and laboratory sinks (<i>third revision</i>)	(Part 6) : 1995	Specific requirements of urinals and partition plates (<i>fourth revision</i>)
(Part 3/Sec 1) : 1979	Specific requirements of urinals, Section 1 Slab urinals (<i>second revision</i>)	(Part 7) : 1995	Specific requirements of accessories for sanitary appliances (<i>third revision</i>)
(Part 3/Sec 2) : 1985	Part 3 Specific requirements of urinals, Section 2 Stall urinals (<i>third revision</i>)	(Part 8) : 1995	Specific requirements of siphonic wash-down water closets (<i>fourth revision</i>)

<i>IS No.</i>	<i>Title</i>	<i>IS No.</i>	<i>Title</i>
(Part 9) : 1995	Specific requirements of bidets (<i>fourth revision</i>)	3950 : 1979	Specification for surface boxes for sluice valves (<i>first revision</i>)
(Part 14) : 1995	Specific requirements of integrated squatting pans (<i>first revision</i>)	4038 : 1986	Specification for foot valves for water works purposes (<i>second revision</i>)
(Part 15) : 1995	Specific requirements of universal water closets (<i>first revision</i>)	4346 : 1982	Specification for washers for use with fittings for water services (<i>first revision</i>)
(Part 16) : 2002	Specific requirements for wash down wall mounted water-closets	5312	Specification for swing check type reflux (non-return) valves:
(Part 17) : 1995	Specific requirements for wall mounted bidets	(Part 1) : 1984	Single door pattern (<i>first revision</i>)
5961 : 1970	Specification for cast iron gratings for drainage purposes	(Part 2) : 1986	Multi-door pattern
7231 : 1984	Specification for plastic flushing cisterns for water-closets and urinals (<i>second revision</i>)	8931 : 1993	Specification for cast copper alloy fancy single tap combination tap and stop valves for water services (<i>first revision</i>)
11246 : 1992	Specification for glass fibre reinforced polyester resins (GRP) squatting pans (<i>first revision</i>)	9338 : 1984	Specification for cast iron screw-down stop valves and stop and check valves for water works purposes (<i>first revision</i>)
d) Valves and Fittings (Including Ferrules)			
778 : 1984	Specification for copper alloy gate, globe, and check valves for water works purposes (<i>fourth revision</i>)	9739 : 1981	Specification for pressure reducing valves for domestic water supply systems
781 : 1984	Specification for cast copper alloy screw-down bib taps and stop valves for water services (<i>third revision</i>)	9758 : 1981	Specification for flush valves and fittings for water-closets and urinals
1701 : 1960	Specification for mixing valves for ablutionary and domestic purposes	9762 : 1994	Specification for polyethylene floats (spherical) for float valves (<i>first revision</i>)
1703 : 2000	Specification for copper alloy float valves (horizontal plunger type) for water supply fittings (<i>third revision</i>)	9763 : 2000	Specification for plastic bib taps, pillar taps, angle valves, hot and cold water services (<i>second revision</i>)
1711 : 1984	Specification for self-closing taps for water supply purposes (<i>second revision</i>)	12234 : 1988	Specification for plastic equilibrium float valve for cold water services
1795 : 1982	Specification for pillar taps for water supply purposes (<i>second revision</i>)	13049 : 1991	Specification for diaphragm type (plastic body) float operated valves for cold water services
2692 : 1989	Specification for ferrules for water services (<i>second revision</i>)	13114 : 1991	Specification for forged brass gate, globe and check valves for water works purposes
3004 : 1979	Specification for plug cocks for water supply purposes (<i>first revision</i>)	14845 : 2000	Specification for resilient seated cast iron air relief valves for water works purposes
3042 : 1965	Specification for single faced sluice gates (200 to 1 200 mm size)	14846 : 2000	Specification for sluice valves for water works purposes (50 to 1 200 mm)
3311 : 1979	Specification for waste plug and its accessories for sinks and washbasins (<i>first revision</i>)	e) Water Meters	
		779 : 1994	Specification for water meters (domestic type) (<i>sixth revision</i>)

<i>IS No.</i>	<i>Title</i>	<i>IS No.</i>	<i>Title</i>
2104 : 1981	Specification for water meter boxes (domestic type) (<i>first revision</i>)	8500 : 1991	Specification for structural steels microalloyed (medium and high strength qualities)
2373 : 1981	Specification for water meters (bulk type) (<i>third revision</i>)	8952 : 1995	Steel ingots, blooms and billets for production of mild steel wire rods for general engineering purposes (<i>first revision</i>)
6784 : 1996	Method for performance testing of water meters (domestic type) (<i>second revision</i>)	9467 : 1980	Steel ingots and billets for production of rivet bars for structural purposes
20. SOIL-BASED PRODUCTS			
1725 : 1982	Specification for soil-based blocks used in general building construction	c) Sheet and Strip	
21. STEEL AND ITS ALLOYS			
a) General			
1030 : 1998	Carbon steel castings for general engineering purposes (<i>fifth revision</i>)	277 : 2003	Specification for galvanized steel sheets (plain and corrugated) (<i>sixth revision</i>)
1136 : 1990	Preferred sizes for wrought metal products (<i>first revision</i>)	412 : 1975	Specification for expanded metal steel sheets for general purposes (<i>second revision</i>)
1137 : 1990	Thickness of sheet and diameters of wire (<i>first revision</i>)	513 : 1994	Specification for cold rolled low carbon steel sheets and strips (<i>fourth revision</i>)
1762 (Part 1) : 1974	Code for designation of steels: Part 1 Based on letter symbols (<i>first revision</i>)	1079 : 1994	Specification for hot rolled carbon steel sheet and strip (<i>fifth revision</i>)
2049 : 1978	Colour code for the identification of wrought steel for general engineering purposes (<i>first revision</i>)	6911 : 1992	Stainless steel plate, sheet and strip (<i>first revision</i>)
2644 : 1994	High tensile steel castings (<i>fourth revision</i>)	7226 : 1974	Specification for cold rolled medium, high carbon and low alloy steel strip for general engineering purposes
7598 : 1990	Classification of steels (<i>first revision</i>)	11587 : 1986	Specification for structural weather resistant steels
b) Structural Steel			
1977 : 1996	Specification for low tensile structural steels (<i>third revision</i>)	14246 : 1995	Specification for continuously pre-painted galvanized steel sheets and coils
2062 : 1999	Specification for steel for general structural purposes (<i>fifth revision</i>)	15103 : 2002	Specification for fire resistant steel
2830 : 1992	Specification for carbon steel billets ingots, blooms and slabs for re-rolling into steel for general structural purposes (<i>second revision</i>)	d) Bars, Rods, Wire and Wire Rods	
2831 : 2000	Specification for carbon steel billets ingots, blooms and slabs for re-rolling into low tensile structural steel (<i>third revision</i>)	280 : 1978	Specification for mild steel wire for general engineering purposes (<i>third revision</i>)
8053 : 1976	Specification for steel ingots and billets for the production of steel wire for the manufacture of wood screws	1148 : 1982	Specification for hot rolled steel rivet bars (up to 40 mm diameter) for structural purposes (<i>third revision</i>)
		1149 : 1982	Specification for high tensile steel rivet bars for structural purposes (<i>third revision</i>)
		1673 : 1984	Specification for mild steel wire cold heading quality (<i>second revision</i>)

<i>IS No.</i>	<i>Title</i>	<i>IS No.</i>	<i>Title</i>
1812 : 1982	Specification for carbon steel wire for the manufacture of wood screw (<i>second revision</i>)	1122 : 1974	Method of test for determination of true specific gravity of natural building stones (<i>first revision</i>)
1835 : 1976	Specification for round steel wire for ropes (<i>third revision</i>)	1123 : 1975	Method of identification of natural building stones (<i>first revision</i>)
2591 : 1982	Dimensions for hot rolled bars for threaded components (<i>second revision</i>)	1124 : 1974	Method of test for determination of water absorption, apparent specific gravity and porosity of natural building stones (<i>first revision</i>)
3150 : 1982	Specification for hexagonal wire netting for general purposes	1125 : 1974	Method of test for determination of weathering of natural building stones (<i>first revision</i>)
4826 : 1979	Specification for hot-dipped galvanized coatings on round steel wires (<i>first revision</i>)	1126 : 1974	Method of test for determination of durability of natural building stones (<i>first revision</i>)
6527 : 1995	Stainless steel wire rod (<i>first revision</i>)	1127 : 1970	Recommendations for dimensions and workmanship of natural building stones for masonry work (<i>first revision</i>)
6528 : 1995	Specification for stainless steel wire (<i>first revision</i>)	1128 : 1974	Specification for limestone (slab and tiles) (<i>first revision</i>)
6603 : 2001	Specification for stainless steel bars and flats (<i>first revision</i>)	1129 : 1972	Recommendation for dressing of natural building stones (<i>first revision</i>)
7887 : 1992	Specification for mild steel wire rods for general engineering purposes (<i>first revision</i>)	1130 : 1969	Specification for marble (blocks, slabs and tiles)
10631 : 1983	Stainless steel for welding electrode core wire	1706 : 1972	Method of determination of resistance to wear by abrasion of natural building stones (<i>first revision</i>)
e) Plates			
3502 : 1994	Specification for steel chequered plates (<i>second revision</i>)	3316 : 1974	Specification for structural granite (<i>first revision</i>)
f) Tubes and Tubulars			
1161 : 1998	Specification for steel tubes for structural purposes (<i>fourth revision</i>)	3620 : 1979	Specification for laterite stone block for masonry (<i>first revision</i>)
4516 : 1968	Specification for elliptical mild steel tubes	3622 : 1977	Specification for sand stone (slabs and tiles) (<i>first revision</i>)
4923 : 1997	Specification for hollow mild steel sections for structural use (<i>first revision</i>)	4121 : 1967	Method of test for determination of water transmission rate by capillary action through natural building stones
g) Slotted Sections			
8081 : 1976	Specification for slotted sections	4122 : 1967	Method of test for surface softening of natural building stones by exposure to acidic atmospheres
22. STONES			
1121	Methods of test for determination of strength properties of natural building stones:	4348 : 1973	Methods of test for determination of permeability of natural building stones (<i>first revision</i>)
(Part 1) : 1974	Compressive strength (<i>first revision</i>)	5218 : 1969	Method of test for toughness of natural building stones
(Part 2) : 1974	Transverse strength (<i>first revision</i>)	5640 : 1970	Method of test for determining the aggregate impact value of soft coarse aggregates
(Part 3) : 1974	Tensile strength (<i>first revision</i>)		
(Part 4) : 1974	Shear strength (<i>first revision</i>)		

<i>IS No.</i>	<i>Title</i>	<i>IS No.</i>	<i>Title</i>
6250 : 1981	Specification for roofing slate tiles (<i>first revision</i>)	1863 : 1979	Specification for hot rolled steel bulb flats (<i>first revision</i>)
7779	Schedule for properties and availability of stones for construction purposes:	2314 : 1986	Specification for steel sheet piling sections (<i>first revision</i>)
(Part 1/Sec 1) : 1975	Gujarat state, Section 1 Availability of stones	3443 : 1980	Specification for crane rail sections (<i>first revision</i>)
(Part 1/Sec 2) : 1975	Gujarat state, Section 2 Engineering properties of building stones	3908 : 1986	Specification for aluminium equal leg angles (<i>first revision</i>)
(Part 1/Sec 3) : 1975	Gujarat state, Section 3 Engineering properties of stone aggregates	3909 : 1986	Specification for aluminium unequal leg angles (<i>first revision</i>)
(Part 2/Sec 1) : 1979	Maharashtra state, Section 1 Availability of stones	3921 : 1985	Specification for aluminium channels (<i>first revision</i>)
(Part 2/Sec 2) : 1979	Maharashtra state, Section 2 Engineering properties of building stones	3954 : 1991	Specification for hot rolled steel channels sections for general engineering purposes (<i>first revision</i>)
(Part 2/Sec 3) : 1979	Maharashtra state, Section 3 Engineering properties of stone aggregates	3964 : 1980	Specification for light rails (<i>first revision</i>)
(Part 3/Sec 2) : 1990	Tamil Nadu state, Section 2 Engineering properties of building stones	5384 : 1985	Specification for aluminium I-beams (<i>first revision</i>)
(Part 3/Sec 3) : 1980	Tamil Nadu state, Section 3 Engineering properties of stone aggregates	6445 : 1985	Specification for aluminium tee sections (<i>first revision</i>)
(Part 4/Sec 1 to 3) : 1996	Karnataka state, Sections (1 to 3)	12779 : 1989	Rolling and cutting tolerances for hot rolled parallel flange beam and column sections
(Part 5/Sec 1) : 1997	Andhra Pradesh, Section 1 Availability of stones	b) Dimensional Standards	
(Part 5/Sec 2) : 1997	Andhra Pradesh, Section 2 Engineering properties of building stones	808 : 1989	Dimensions for hot rolled steel beam, column channel and angle sections (<i>third revision</i>)
(Part 5/Sec 3) : 1997	Andhra Pradesh, Section 3 Engineering properties of stone aggregates	1730 : 1989	Dimensions for steel plates, sheets strips and flats for general engineering purposes (<i>second revision</i>)
9394 : 1979	Specification for stone lintels	1732 : 1989	Dimensions for round and square steel bars for structural and general engineering purposes (<i>second revision</i>)
14223 (Part 1) : 1994	Specification for polished building stones: Part 1 Granite	2525 : 1982	Dimensions for wrought aluminium and aluminium alloy wire (<i>first revision</i>)
23. STRUCTURAL SECTIONS			
a) Structural Shapes			
811 : 1987	Specification for cold formed light gauge structural steel sections (<i>revised</i>)	2591 : 1982	Dimensions for hot rolled steel bars for threaded components (<i>second revision</i>)
1173 : 1978	Specification for hot rolled and slit steel tee bars (<i>second revision</i>)	2673 : 2002	Dimensions for wrought aluminium and aluminium alloys, extruded round tube (<i>second revision</i>)
1852 : 1985	Specification for rolling and cutting tolerances for hot rolled steel products (<i>fourth revision</i>)	2676 : 1981	Dimensions for wrought aluminium and aluminium alloys, sheet and strip (<i>first revision</i>)

<i>IS No.</i>	<i>Title</i>	<i>IS No.</i>	<i>Title</i>
2677 : 1979	Dimensions for wrought aluminium and aluminium alloys, plates and hot rolled sheets (<i>first revision</i>)	9403 : 1980	Method of test for thermal conductance and transmittance of built up sections by means of guarded hot box
2678 : 1987	Dimensions and tolerances for wrought aluminium and aluminium alloys, drawn round tubes (<i>second revision</i>)	9489 : 1980	Method of test for thermal conductivity of materials by means of heat flow meter
3577 : 1992	Dimensions and tolerances for wrought aluminium and aluminium alloys rivet, bolt and screw stock (<i>first revision</i>)	9490 : 1980	Method of determination for thermal conductivity of insulation materials (water calorimeter method)
3965 : 1981	Dimensions for wrought aluminium and aluminium alloys, bar, rod and section (<i>first revision</i>)	9742 : 1993	Specification for sprayed mineral wool thermal insulation (<i>first revision</i>)
6477 : 1983	Dimensions for wrought aluminium and aluminium alloys, extruded hollow sections	9743 : 1990	Specification for thermal insulation finishing cements (<i>first revision</i>)
12778 : 1989	Dimensions for hot rolled steel parallel flange beam and column sections	9842 : 1994	Specification for preformed fibrous pipe insulation (<i>first revision</i>)
		11128 : 1994	Specification for spray applied hydrated calcium silicate thermal insulation
		11129 : 1984	Method of test for tumbling friability of preformed block-type thermal insulation
24. THERMAL INSULATION MATERIALS		11239	Method of test for rigid cellular thermal insulation materials:
3144 : 1992	Methods of test for mineral wool thermal insulation material (<i>second revision</i>)	(Part 1) : 1985	Dimensions
3346 : 1980	Methods for the determination of thermal conductivity of thermal insulation materials (two slab, guarded hot-plate method) (<i>first revision</i>)	(Part 2) : 1985	Apparent density
3677 : 1985	Specification for unbonded rock and slag wool for thermal insulation (<i>second revision</i>)	(Part 3) : 1985	Dimensional stability
4671 : 1984	Specification for expanded polystyrene for thermal insulation purposes (<i>first revision</i>)	(Part 4) : 1985	Water vapour transmission rate
5688 : 1982	Methods of test for preformed block-type and pipe-covering type thermal insulation (<i>first revision</i>)	(Part 5) : 1985	Volume percent of open and closed cells
5724 : 1970	Methods of test for thermal insulating cement	(Part 6) : 1985	Heat distortion temperature
6598 : 1972	Specification for cellular concrete for thermal insulation	(Part 7) : 1985	Coefficient of linear thermal expansion at low temperatures
7509 : 1993	Specification for thermal insulating cement (<i>first revision</i>)	(Part 8) : 1985	Flame height, time of burning and loss of mass
8154 : 1993	Specification for preformed calcium silicate insulation for temperature up to 650°C (<i>first revision</i>)	(Part 9) : 1985	Water absorption
8183 : 1993	Specification for bonded mineral wool (<i>first revision</i>)	(Part 10) : 1985	Flexural strength
		(Part 11) : 1985	Compressive strength
		(Part 12) : 1989	Horizontal burning characteristics
		(Part 13) : 1992	Determination of flammability by oxygen index
		11307 : 1985	Specification for cellular glass block and pipe thermal insulating
		11308 : 1985	Specification for thermal insulating castables (hydraulic setting) for temperatures up to 1 250°C

<i>IS No.</i>	<i>Title</i>	<i>IS No.</i>	<i>Title</i>
12436 : 1988	Specification for preformed rigid polyurethane (PUR) and polyisocyanurate (Pir) foams for thermal insulation	(Part 3) : 2002	Hexagon nuts (size range M1.6 to M64) (<i>fourth revision</i>)
13204 : 1991	Specification for rigid phenolic foams for thermal insulation	(Part 4) : 2003	Hexagon thin nuts (chamfered) (size range M1.6 to M64) (<i>fourth revision</i>)
13286 : 1992	Methods of test for surface spread of flame for thermal insulation materials	(Part 5) : 2002	Hexagon thin nuts (unchamfered) (size range M1.6 to M10) (<i>fourth revision</i>)
		(Part 6) : 2002	Hexagon nuts, style 2
25. THREADED FASTENERS AND RIVETS		1365 : 1978	Specification for slotted countersunk head screws (<i>third revision</i>)
207 : 1964	Specification for gate and shutter hooks and eyes (<i>revised</i>)	1366 : 2002	Specification for slotted cheese head screws (<i>third revision</i>)
451 : 1999	Specification for technical supply conditions for wood screws (<i>third revision</i>)	1367	Specification for technical supply conditions for threaded steel fasteners:
554 : 1999	Specification for pipe threads where pressure-tite joints are made on the threads — Dimensions, tolerances and designation (<i>fourth revision</i>)	(Part 1) : 2002	Introduction and general information (<i>third revision</i>)
723 : 1972	Specification for steel countersunk head wire nails (<i>second revision</i>)	(Part 2) : 2002	Product grades and tolerances (<i>third revision</i>)
724 : 1964	Specification for mild steel and brass cup, ruler and square hooks and screw eyes (<i>revised</i>)	(Part 3) : 2002	Mechanical properties and test methods for bolts, screws and studs with full loadability (<i>fourth revision</i>)
725 : 1961	Specification for copper wire nails (<i>revised</i>)	(Part 5) : 2002	Mechanical properties and test methods for set screws and similar threaded fasteners not under tensile stresses (<i>third revision</i>)
730 : 1978	Specification for hook bolts for corrugated sheet roofing (<i>second revision</i>)	(Part 6) : 1994	Mechanical properties and test methods for nuts with specified proof loads (<i>third revision</i>)
1120 : 1975	Specification for coach screws (<i>first revision</i>)	(Part 7) : 1980	Mechanical properties and test methods for nuts without specified proof loads (<i>second revision</i>)
1363	Specification for hexagon head bolts, screws and nuts of product grade C:	(Part 8) : 2002	Mechanical and performance properties for prevailing torque type steel hexagon nuts (<i>third revision</i>)
(Part 1) : 2002	Hexagon head bolts (size range M5 to M64) (<i>fourth revision</i>)	(Part 9/Sec 1) : 1993	Surface discontinuities, Section 1 Bolts, screws and studs for general applications (<i>third revision</i>)
(Part 2) : 2002	Hexagon head screws (size range M5 to M64) (<i>fourth revision</i>)	(Part 9/Sec 2) : 1993	Surface discontinuities, Section 2 Bolts, screws and studs for special applications (<i>third revision</i>)
(Part 3) : 2002	Part 3 Hexagon nuts (Size range M5 to M64) (<i>fourth revision</i>)	(Part 10) : 2002	Surface discontinuities on nuts (<i>third revision</i>)
1364	Specification for hexagon head bolts, screws and nuts of product Grades A and B:	(Part 11) : 2002	Electroplated coatings (<i>third revision</i>)
(Part 1) : 2002	Hexagon head bolts (size range M1.6 to M64) (<i>fourth revision</i>)	(Part 12) : 1981	Phosphate coatings on threaded fasteners (<i>second revision</i>)
(Part 2) : 2002	Hexagon head screws (size range M1.6 to M64) (<i>fourth revision</i>)		

<i>IS No.</i>	<i>Title</i>	<i>IS No.</i>	<i>Title</i>
(Part 13) : 1983	Hot dip galvanized coatings on threaded fasteners (<i>second revision</i>)	4206 : 1987	Dimensions for nominal lengths, and thread lengths for bolts, screws and studs (<i>first revision</i>)
(Part 14/Sec 1) : 2002	Mechanical properties of corrosion resistance stainless steel fasteners, Section 1 Bolts, screws and studs (<i>third revision</i>)	4762 : 2002	Specification for worm drive hose clips for general purposes (<i>second revision</i>)
(Part 14/Sec 2) : 2002	Mechanical properties of corrosion resistance stainless steel fasteners, Section 2 Nuts (<i>third revision</i>)	5369 : 1975	General requirements for plain washers and lock washers (<i>first revision</i>)
(Part 14/Sec 3) : 2002	Mechanical properties of corrosion resistance stainless steel fasteners, Section 3 Set screws and similar fasteners not under tensile stress (<i>third revision</i>)	5372 : 1975	Specification for taper washer for channels (ISMC) (<i>first revision</i>)
(Part 16) : 2002	Designation system and symbols (<i>third revision</i>)	5373 : 1969	Specification for square washers for wood fastenings
1929 : 1982	Specification for hot forged steel rivets for hot closing (12 to 36 mm diameter) (<i>first revision</i>)	5374 : 1975	Specification for taper washers for L-beam (ISMB) (<i>first revision</i>)
2016 : 1967	Specification for plain washers (<i>first revision</i>)	5624 : 1993	Specification for foundation bolts (<i>first revision</i>)
2155 : 1982	Specification for cold forged solid steel rivets for hot closing (6 to 16 mm diameter) (<i>first revision</i>)	6113 : 1970	Specification for aluminium fasteners for building purposes
2585 : 1968	Specification for black square bolts and nuts (dia range 6 to 39 mm) and black square screws (dia range 6 to 24 mm) (<i>first revision</i>)	6610 : 1972	Specification for heavy washers for steel structures
2643 : 1999	Dimensions, tolerances and designation for pipe threads where pressure-tight joints are not made on the threads (<i>second revision</i>)	6623 : 1985	Specification for high strength structural nuts (<i>first revision</i>)
2687 : 1991	Specification for cap nuts (<i>second revision</i>)	6639 : 1972	Specification for hexagon bolts for steel structures
2907 : 1998	Specification for non-ferrous rivets (<i>first revision</i>)	6649 : 1985	Specification for hardened and tempered washers for high strength structural bolts and nuts (<i>first revision</i>)
2998 : 1982	Specification for cold forged steel rivets for cold closing (1 to 16 mm diameter) (<i>first revision</i>)	6733 : 1972	Specification for wall and roofing nails
3063 : 1994	Specification for fasteners single coil rectangular section spring lock washers (<i>second revision</i>)	6736 : 1972	Specification for slotted raised countersunk head wood screws
3121 : 1981	Specification for rigging screws and stretching screws (<i>first revision</i>)	6739 : 1972	Specification for slotted round head wood screws
3468 : 1991	Specification for pipe nuts (<i>second revision</i>)	6760 : 1972	Specification for slotted countersunk head wood screws
3757 : 1985	Specification for high strength structural bolts (<i>second revision</i>)	8033 : 1976	Specification for washers with square hole for wood fastenings
		8412 : 1977	Specification for slotted countersunk head bolts for steel structures
		8822 : 1978	Specification for slotted mushroom head roofing bolts
		8869 : 1978	Specification for washers for corrugated sheet roofing
		8911 : 1978	Specification for slotted raised countersunk head screws
		10102 : 1982	Specification for technical supply conditions for rivets

<i>IS No.</i>	<i>Title</i>	<i>IS No.</i>	<i>Title</i>
10238 : 2001	Specification for step bolts for steel structures	(Part 4) : 1993	Pressure head test
12427 : 2001	Specification for transmission tower bolts	(Part 5) : 1993	Heat resistance test
		(Part 6) : 1993	Water absorption test
		(Part 7) : 1993	Determination of binder content
26. UNIT WEIGHTS OF BUILDING MATERIALS		14695 : 1999	Specification for glass fibre base coal tar pitch outer wrap
875 (Part 1) : 1987	Code of practice for design loads (other than earthquake) for buildings and structures: Part 1 Dead loads — Unit weights of building material and stored materials (<i>second revision</i>)	28. WELDING ELECTRODES AND WIRES	
		814 : 1991	Specification for covered electrodes for manual metal arc welding of carbon and carbon manganese steel (<i>fifth revision</i>)
27. WATERPROOFING AND DAMP-PROOFING MATERIALS		1278 : 1972	Specification for filler rods and wires for gas welding (<i>second revision</i>)
1322 : 1993	Specification for bitumen felts for waterproofing and damp-proofing (<i>fourth revision</i>)	1395 : 1982	Specification for low and medium alloy steel covered electrodes for manual metal arc welding (<i>third revision</i>)
1580 : 1991	Specification for bituminous compound for waterproofing and caulking purposes (<i>first revision</i>)	2879 : 1998	Mild steel for metal arc welding electrodes (<i>third revision</i>)
3037 : 1986	Specification for bitumen mastic for use in waterproofing of roofs (<i>first revision</i>)	3613 : 1974	Acceptance tests for wire flux combinations for submerged-arc welding of structural steel (<i>first revision</i>)
3384 : 1986	Specification for bitumen primer for use in waterproofing and damp-proofing (<i>first revision</i>)	4972 : 1968	Specification for resistance spot-welding electrodes
5871 : 1987	Specification for bitumen mastic for tanking and damp-proofing (<i>first revision</i>)	5206 : 1983	Covered electrodes for manual arc welding of stainless steel and other similar high alloy steels (<i>first revision</i>)
7193 : 1994	Specification for glass fibre base coal tar pitch and bitumen felts (<i>first revision</i>)	5511 : 1991	Specification for covered electrodes for manual metal arc welding of cast iron (<i>first revision</i>)
12027 : 1987	Specification for silicone-based water repellents	5897 : 1985	Specification for aluminium and aluminium alloy welding rods and wires and magnesium alloy welding rods (<i>first revision</i>)
13435	Method of tests for acrylic based waterproofing material:	5898 : 1970	Specification for copper and copper alloy bare solid welding rods and electrodes
(Part 1) : 1992	Determination of solid content	6419 : 1996	Specification for welding rods and bare electrodes for gas shielded arc welding of structural steel (<i>first revision</i>)
(Part 2) : 1992	Determination of coarse particle	6560 : 1996	Specification for molybdenum and chromium-molybdenum low alloy steel welding rods and bare electrodes for gas shielded arc welding (<i>first revision</i>)
(Part 3) : 1992	Determination of capillary water take-up		
(Part 4) : 1992	Determination of pH value		
(Part 5) : 1992	Determination of minimum film forming temperature and white point		
13826	Bitumen based felts — Method of test:		
(Part 1) : 1993	Breaking strength test		
(Part 2) : 1993	Pliability test		
(Part 3) : 1993	Storage sticking test		

<i>IS No.</i>	<i>Title</i>	<i>IS No.</i>	<i>Title</i>
7280 : 1974	Specification for bare wire electrodes for submerged-arc welding of structural steels	2266 : 2002	Specification for steel wire ropes for general engineering purposes (<i>fourth revision</i>)
8363 : 1976	Specification for bare wire electrodes for electroslag welding of steels	2365 : 1977	Specification for steel wire suspension ropes for lifts, elevators and hoists (<i>first revision</i>)
10631 : 1983	Stainless steel for welding electrode core wire	2721 : 2003	Specification for galvanized steel wire chain link fences fabric (<i>second revision</i>)
29. WIRE ROPES AND WIRE PRODUCTS			
278 : 1978	Specification for galvanized steel barbed wire for fencing (<i>third revision</i>)	6594 : 1977	Specification for technical supply conditions for wire ropes and strands (<i>first revision</i>)
2140 : 1978	Specification for stranded galvanized steel wire for fencing (<i>first revision</i>)	12776 : 2002	Specification for galvanized strand for earthing (<i>first revision</i>)

NATIONAL BUILDING CODE OF INDIA

PART 10 LANDSCAPING, SIGNS AND OUTDOOR DISPLAY STRUCTURES

Section 1 Landscape Planning and Design

BUREAU OF INDIAN STANDARDS

CONTENTS

FOREWORD	...	3
1 SCOPE	...	5
2 TERMINOLOGY	...	5
3 PERMIT	...	6
4 PROTECTION OF LANDSCAPE DURING CONSTRUCTION	...	8
5 SOIL AND WATER CONSERVATION	...	9
6 EARTH SLOPES AND GRADING REQUIREMENTS	...	12
7 PLANTING DESIGN CONSIDERATIONS	...	13
8 SPECIFICATIONS FOR PLANTING WORKS	...	20
9 SERVICE UTILITIES IN LANDSCAPE	...	24
10 PAVED SURFACES IN EXTERNAL AREAS	...	26
11 STREET FURNITURE	...	26

FOREWORD

This Part of the Code was first published in 1970 and subsequently revised in 1983, and covered provisions relating to only signs and outdoor display structures. In this revision, this Part has been sub-divided into two sections as follows by including a new section on landscaping:

- Section 1 Landscape planning and design
- Section 2 Signs and outdoor display structures

This Section covers the requirement of landscape planning and design with the aim of improving quality of outdoor built environment and protection of the land and its resources. With growing urban development and environmental degradation it has become imperative to determine landscape design parameters, and also provide rules, regulations, controls and procedures for the protection, preservation and modification of surrounding environment. A brief clause on street furniture has also been introduced in this Section.

The components of landscape design and external development were earlier covered in the Code in its various Parts/Sections but a comprehensive treatment has been given in this new Section in this revision.

NATIONAL BUILDING CODE OF INDIA

PART 10 LANDSCAPING, SIGNS AND OUTDOOR DISPLAY STRUCTURES

Section 1 Landscape Planning and Design

1 SCOPE

This Section covers requirements of landscape planning and design with the view to promoting quality of outdoor built environment and protection of land and its resources.

2 TERMINOLOGY

2.0 For the purpose of this Section, the following definitions shall apply.

2.1 Avenue — A wide road or pathway lined with trees on either sides.

2.2 Buffer — The use of landscape to curtail view, sound or dust with plants or earth berms, wall, or any such element.

2.3 Climber (Creeper/Vine) — A non-supporting plant, woody or herbaceous, which clings to a wall, trellis or other structures as it grows upward.

2.4 Columnar — A slender, upright plant form.

2.5 Contour — The form of the land, existing or proposed; a part of the topography, indicated by map lines at intervals as desired, to understand the landform clearly. The contour line though imaginary, indicates continuous elevation above mean sea level or an assumed datum line.

2.6 Contour Interval — The difference in elevation or the vertical distance measured between consecutive contour lines.

2.7 Egress — A way out, or exit.

2.8 Elevation — A contour line or notation of relative altitude, useful in plotting existing or proposed feature.

2.9 Exotic — A plant that is not native to the area in which it is planted.

2.10 Fencing — A barrier of plant or construction material used to set off the boundary of an area and to restrict visual or physical passage in or out of it.

2.11 Foliage — The collective leaves of a plant or plants.

2.12 Geo-textile — Any permeable textile (natural or synthetic) used with foundation, soil, rock, earth or any other geotechnical engineering-related material as an integral part of a human made project, structure or system.

2.13 Grade — The slope or lay of the land as indicated by a related series of elevations.

2.13.1 Natural Grade — Grade consisting of contours of unmodified natural landform.

2.13.2 Finished Grade — Grade accomplished after landscape features are installed and completed as shown on plan as proposed contours.

2.14 Gradient — The degree of slope of a pipe invert or road or land surface. The gradient is a measure of the slope height as related to its base. The slope is expressed in terms of percentage or ratio.

2.15 Grading — The cutting and/or filling of earth to establish smooth finish contours for a landscape construction project. Grading facilitates good drainage and sculpts land to suit the intent of landscape design.

2.16 Grasses — Plants that characteristically have joint stems, sheaths and narrow blades (leaves).

2.17 Groundcover — The planting material that forms a carpet of low height; these low-growing plants are usually installed as the final part of landscape construction.

2.18 Hard Landscape — Civil work component of landscape architecture such as pavement, walkways, roads, retaining walls, sculpture, street amenities, fountains and other built environment.

2.19 Hardy Plant — Plants that can withstand harsh temperature variations, pollution, dust, extreme soil conditions, and minimal water requirements and the likes. These plants have ability to remain dormant in such conditions and survive.

2.20 Hedge — Number of shrubs or trees (often similar species) planted closely together in a line. A hedge may be pruned to shape or allowed to grow to assume its natural shape.

2.21 Herb — An annual plant with a non-woody or fleshy structure. Certain herbs are highly useful for cooking or of high medicinal value.

2.22 Ingress — A way in, or entrance.

2.23 Invert — The low inside point of a pipe, culvert, or channel.

2.24 Kerb — A concrete or stone edging along a pathway or road often constructed with a channel to guide the flow of storm water and thereby serving dual purpose.

2.25 Mound — A small hill or bank of earth, developed as a characteristic feature in landscape.

2.26 Native — A plant indigenous to a particular locale.

2.27 Screen — A vegetative or constructed hedge or fence used to block wind, undesirable views, noise, glare and the like, as part of in landscape design; also known as 'screen planting' and 'buffer plantation'.

2.28 Sediment — The product of erosion processes; the solid material, both mineral and organic, that is in suspension, is being transported or has been moved from its site of origin by air, water, gravity or ice.

2.29 Shrub — A woody plant of low to medium height, deciduous or evergreen, generally having many stem.

2.30 Soft Landscape — The natural elements in landscape design, such as plant materials and the soil itself.

2.31 Spot Elevation — In surveying and contour layout, an existing or proposed elevation noted as a dot on the plan.

2.32 Street/Outdoor Furniture — Items of furnishing in outdoor landscape.

2.33 Swale — A linear wide and shallow depression used to temporarily store, route or filter runoff. A swale may be grassed or lined.

2.34 Topsoil — The uppermost layer of the soil.

2.35 Transplanting — Moving a plant from its place of origin to another location.

2.36 Tree — A woody plant, generally taller than 2.00 m, with a well-distinguished trunk or trunks below the leaf crown.

2.36.1 Deciduous Tree — Tree that sheds all its leaves in autumn or in dry season.

2.36.2 Evergreen Tree — Tree that remains green for most part of the year and sheds leave slowly throughout the year.

2.37 Tree Grate — A metal grille, installed at the base of a tree otherwise surrounded by pavement, that allows the free passage of air, water, and nutrients to the tree root, but does not interfere with the foot traffic.

2.38 Tree/Plant Guard — The protection constructed around a tree to deter vandalism and help to prevent damage. It could be made of metal, bamboo or concrete or the like.

3 PERMIT

3.1 Application for Licence or Permit and Required Drawings

Any development project for which a permit or licence

is required, shall make application to the Authority on the prescribed form containing such particulars as the Authority may require. The form shall be signed by the owner and shall include the information given in 3.2 to 3.4. For various aspects of obtaining the permit, etc reference shall be made to Part 2 'Administration'.

3.2 Site Plan Contents and Specifications

3.2.1 Site Plan

The site plan to be submitted with the application for permit shall be drawn to a scale of not less than 1 in 500 for a site up to one hectare and not less than 1 in 1 000 for site more than 10 hectare. The following information shall be provided in addition to requirements for Site Plan as stated in Part 2 'Administration':

- a) Existing and proposed topographic contours at interval not exceeding 50 cm and/or spot elevations as pertinent and Bench Mark of site with reference to the City Datum relative to the Mean Sea Level.
- b) Limits of the 100 year flood plain and water surface elevation (when applicable).
- c) Location of existing major physical features, such as railway track, drainage ways etc.
- d) Location of service utilities adjacent to the project with relevant top and invert levels clearly indicated.
- e) Point of egress and ingress including locations and width of road.
- f) Fully dimensioned loading spaces and maneuvering areas.
- g) Parking including, location, parking spaces, size and number, and typical parking space details for both handicapped and standard spaces.
- h) Vehicular, bicycle, pedestrian and handicapped circulation clearly identified.
- j) Detail for parking areas including type of lighting, material for paving, and security rooms, rest rooms; and type of directional signage etc.
- k) Drainage system, proposed finish ground elevations and finish grades.
- m) Location of proposed fire hydrant points.
- n) Location and dimension of fire lanes.
- p) Proposed lighting layout.
- q) Landscape irrigation points and source of water.
- r) Fences, walls, or vegetation for screening by type, material, height, location, and spacing.
- s) Location of proposed street furniture.

- t) Refuse container location, size, and access.
- u) Landscape paving materials with location.
- v) Location, type, size, and height of existing and proposed signage.
- w) List of existing trees with botanical and common names and height of the tree (*see* 4.1.2 for plant material schedule).
- x) Prior approvals.

3.3 Landscape Plan Contents and Specifications

Landscape plan and drawings shall consist of the plans and details as given in 3.3.1 to 3.3.4.

3.3.1 Grading Plan

The grading plan to be submitted with the application for permit shall be drawn to a scale of not less than 1 in 500 for a site up to 10 hectare and not less than 1 in 1 000 for site more than 10 hectare (*see also* 6.2). The grading plan will include measures for soil and sedimentation control and also measures during construction to prevent soil erosion, and also water harvesting practices (*see also* 4 and 5).

3.3.2 Planting Plan

The planting plan shall be drawn to a scale of not less than 1 in 200 for a site up to one hectare and not less than 1 in 500 for site more than 10 hectare with part plans at 1 in 200 of two of the design areas. Planting plan should include plant material schedule as shown in Table 1. The planting plan and landscape plan must show identical information to avoid conflict between both plans. The planting plan shall include the layouts as given below drawn to the scale:

- a) Location of proposed trees, shrubs, ground covers and lawn area indicated clearly with appropriate symbols and legend.
- b) The size of plant material indicated in the drawing should be shown as diameter of canopy for tree and spread for shrubs and ground cover. Two years growth will be considered as full maturity size for shrubs and ground covers and ten years growth will be considered for trees.
- c) The Botanical name could be indicated as a symbol on the main drawing (for example *Delonix regia* as *Dr*). Plant names should to be tabulated in alphabetical order under heads Trees, Shrubs, Groundcovers, Climbers and Grass.
- d) Functional attributes and growth pattern tabulation to be attached as Table 2, as an annex.
- e) All existing vegetation shall be marked on the landscape plan and areas designated for

- preservation of existing vegetation on site shall be demarcated clearly (*see also* 4.1.2).
- f) A concept plan of scale not less than 1 in 1 000 indicating the intent of the design with respect to the functions for various parts of the scheme should be included.

Table 1 Plant Material Schedule
(Clause 3.3.2)

Tree No.	Code	Botanical Name	Common Name	Quantity
(1)	(2)	(3)	(4)	(5)

Table 2 Plant Material Schedule Showing Functional Attributes and Growth Pattern of Each Plant
[Clause 3.3.2 (d)]

Sl No.	Relevant Features	Description Plant -1
(1)	(2)	(3)
i)	Botanical name	
ii)	Common name	
iii)	Plant code	
iv)	Type (Evergreen/Deciduous)	
v)	Height	
vi)	Spread/Canopy	
vii)	Form of Tree	
viii)	Flower colour	
ix)	Seasonal duration	
x)	Zone (Functional Attributes)	
xi)	Characteristics	
xii)	Function	
xiii)	Remarks	

3.3.3 Irrigation Plan

The irrigation plan shall be drawn to a scale of not less than 1 in 500 for a site up to one hectare and not less than 1 in 1 000 for site more than one hectare. The Plan shall include the following information:

- a) The source of irrigation water.
- b) Type of water conserving irrigation systems proposed differentiating between systems for different water use zones on the site.
- c) Extent of supplementary irrigation provided by water harvesting measures.
- d) Arrangement of hydrants or sprinklers indicating location and type with typical details and specifications.

3.3.4 Construction Details

Construction details, specifications and methods used for the following landscape elements are to be included where applicable:

- a) All paved areas for pedestrian and vehicular use, including edges, kerbs, bumper stops, steps, ramps, planters, railings or other protective devices; provision for wheel chair access and movement; Tree protection with tree grating, tree guard, etc.
- b) Boundary wall, fence, retaining wall, etc.
- c) Structures in landscape such as gatehouses, kiosks, toilets, pergolas, space frame, pools, ponds, water bodies, any other special features, etc.
- d) Site utilities such as stormwater drains, manholes, catch basins, outdoor lighting fixtures, electric feeder pillars, junction box, fire hydrant, garbage collection points, litter bins, etc.
- e) Outdoor signage and street furniture.
- f) Play equipment and tot lots where appropriate.
- g) Any other relevant detail or information.

4 PROTECTION OF LANDSCAPE DURING CONSTRUCTION

4.0 Development projects involve disturbance to the existing soil conditions, removal of existing trees and overall change in the microclimate and drainage pattern. Measures to minimize hazardous effects should be put into effect as explained below.

4.1 Pre-Construction Measures

Measures for the prevention of soil erosion, sediment control and management of storm water shall be implemented as given in **4.1.1** to **4.1.5**.

4.1.1 Timing of Construction

Construction work and erosion control applications shall be scheduled and sequenced during dry weather periods when the potential for erosion is the lowest. Slope protection techniques to control erosion shall be used when construction during wet season is unavoidable. Sedimentation collection systems, drainage systems, and runoff diversion devices shall be installed before construction activity. The Landscape Architect/Architect/Engineer-in-charge shall monitor the site conditions and progress of work and schedule appropriate timing and sequencing of construction.

4.1.2 Preservation of Existing Vegetation

4.1.2.1 Protection of existing vegetation (including trees, shrubs, grasses and other plants) where possible, by preventing disturbance or damage to specified areas during construction is recommended. This practice minimizes the amount of bare soil exposed to erosive forces. All existing vegetation shall be marked on a site survey plan. A tree survey in prescribed format shall be

carried out as indicated in Table 3. The landscape plan should indicate trees, which have been preserved, and also those, which had to be transplanted or removed clearly differentiating between these three categories.

Table 3 Plant Material Schedule for Tree Survey
(Clause 4.1.2.1)

Tree No.	Botanical Name	Common Name	Girth	Height	Spread	Condition
(1)	(2)	(3)	(4)	(5)	(6)	(7)

4.1.2.2 Trees retained on the project site shall be protected during the construction period by following measures:

- a) Damage to roots shall be prevented during trenching, placing backfill, driving or parking heavy equipment, dumping of trash, oil, paint, and other materials detrimental to plant health by restricting these activities to outside the area of the canopy of the tree.
- b) Trees will not be used for support; their trunks shall not be damaged by cutting and carving or by nailing posters, advertisements or other material.
- c) Lighting of fires or carrying out heat or gas emitting construction activity within the ground, covered by canopy of the tree shall not be permitted.
- d) Young trees or saplings identified for preservation (height less than 2.00 m, 0.10 m trunk girth at 1.00 m height from finish ground, 2.00 m crown diameter) within the construction site have to be protected using tree guards of approved specification.
- e) Existing drainage patterns through or into any preservation area shall not be modified unless specifically directed by the Landscape Architect/Architect/Engineer-in-charge.
- f) Existing grades shall be maintained around existing vegetation and lowering or raising the levels around the vegetation is not allowed unless specifically directed by the Landscape Architect/Architect/Engineer-in-charge.
- g) Maintenance activities shall be performed as needed to ensure that the vegetation remains healthy.
- h) The preserved vegetated area shall be inspected by the Landscape Architect/Architect/Engineer-in-charge at regular intervals so that they remain undisturbed. The

date of inspection, type of maintenance or restorative action followed shall be recorded in the logbook.

4.1.3 Staging Areas

Measures shall be followed for collecting runoff from construction areas and material storage sites; diverting water flow away from such polluted areas, so that pollutants do not mix with storm water runoff from undisturbed areas.

Temporary drainage channels, perimeter dike/swale, etc shall be constructed to carry the pollutant-laden water directly to treatment device or facility. The plan shall indicate how the above is accomplished on site, well in advance of the commencing of the construction activity.

4.1.4 Preservation of Topsoil

Topsoil removal and preservation shall be mandatory for development projects larger than 1.00 hectare. Topsoil shall be stripped to a depth of 200 mm from areas proposed to be occupied by buildings, roads, paved areas and external services. Topsoil is rich in organic content and is essential to establish new vegetation. It shall be stockpiled to a height of 400 mm in designated areas and shall be re-applied to site during plantation of the proposed vegetation. Topsoil shall be separated from sub-soil debris and stones larger than 50 mm diameter. The stored topsoil may be used as finished grade for planting areas.

4.1.5 Spill Prevention and Control

Spill prevention and control plans shall be made, clearly stating measures to stop the source of the spill, to contain the spill, to dispose the contaminated material and hazardous wastes, and stating designation of personnel trained to prevent and control spills. Hazardous wastes include pesticides, paints, cleaners, petroleum products, fertilizers and solvents.

4.2 Measures During Construction

During construction soil becomes unconsolidated due to removal of stabilizing material such as vegetation and disturbance of stabilized existing grade resulting in loss of topsoil and also deposition in undesirable places. A soil erosion and sedimentation control plan to be prepared prior to construction. The soil erosion, sediment control and storm water practices should be considered whilst construction is proceeding, in accordance with 4.2.1 to 4.2.4.

4.2.1 Sedimentation Basin

A temporary dam or basin at the lowest point of the site has to be constructed for collecting, trapping and storing sediment produced by the construction activities, together with a flow detention facility for

reducing peak runoff rates. This would allow most of the sediments to settle before the runoff is directed towards the outfall.

4.2.2 Contour Trenching

Contour trenching is an earth embankment or ridge-and-channel arrangement constructed parallel to the contours along the face of the slope at regular intervals on long and steep slopes (in sloping areas with slopes greater than 10 percent) (*see Fig. 1*). They are used for reducing runoff velocity, increasing the distance of overland runoff flow, and to hold moisture and minimize sediment loading of surface runoff. Vegetative cover of tree and native grasses in the channels may be planted to stabilize the slopes and reduce erosion.

4.2.3 Mulching

Mulching shall be used with seeding and planting in steep slope areas (slopes greater than 33 percent) that are prone to heavy erosion. Netting or anchoring shall be used to hold it in place. Other surface runoff control measures like contour terracing to break up concentrated flows shall be installed prior to seeding and mulching. Materials such as straw, grass, grass hay and compost shall be placed on or incorporated into the soil surface. In addition to stabilizing soils, mulching will reduce the storm water runoff over an area. Together with seeding or planting, mulching aids plant growth by holding the seed, fertilizers and topsoil in place. It retains moisture and insulates the soil against extreme temperatures.

4.2.4 Geo-grids

A deformed or non-deformed netlike polymeric material used with foundation, soil, rock, earth or any other geo-technical engineering-related material as an integral part of the human-made project structure or system, called geo-grids may be used as control measure. On filling with lightly compacted soil or fine aggregate, a monolithic structure is created providing an effective means of confinement for unconsolidated materials within the cells and preventing their movement even on steep slopes. If required the area can then be seeded to maintain 'green' environment. The junctions have a central opening through which water can permeate ensuring that organic material receives moisture for rapid growth.

5 SOIL AND WATER CONSERVATION

The soil conservation, sediment control and storm water management practices as given in 5.1 to 5.3 shall be followed after construction is completed.

5.1 Vegetative Measures

The vegetative measures shall include the following:

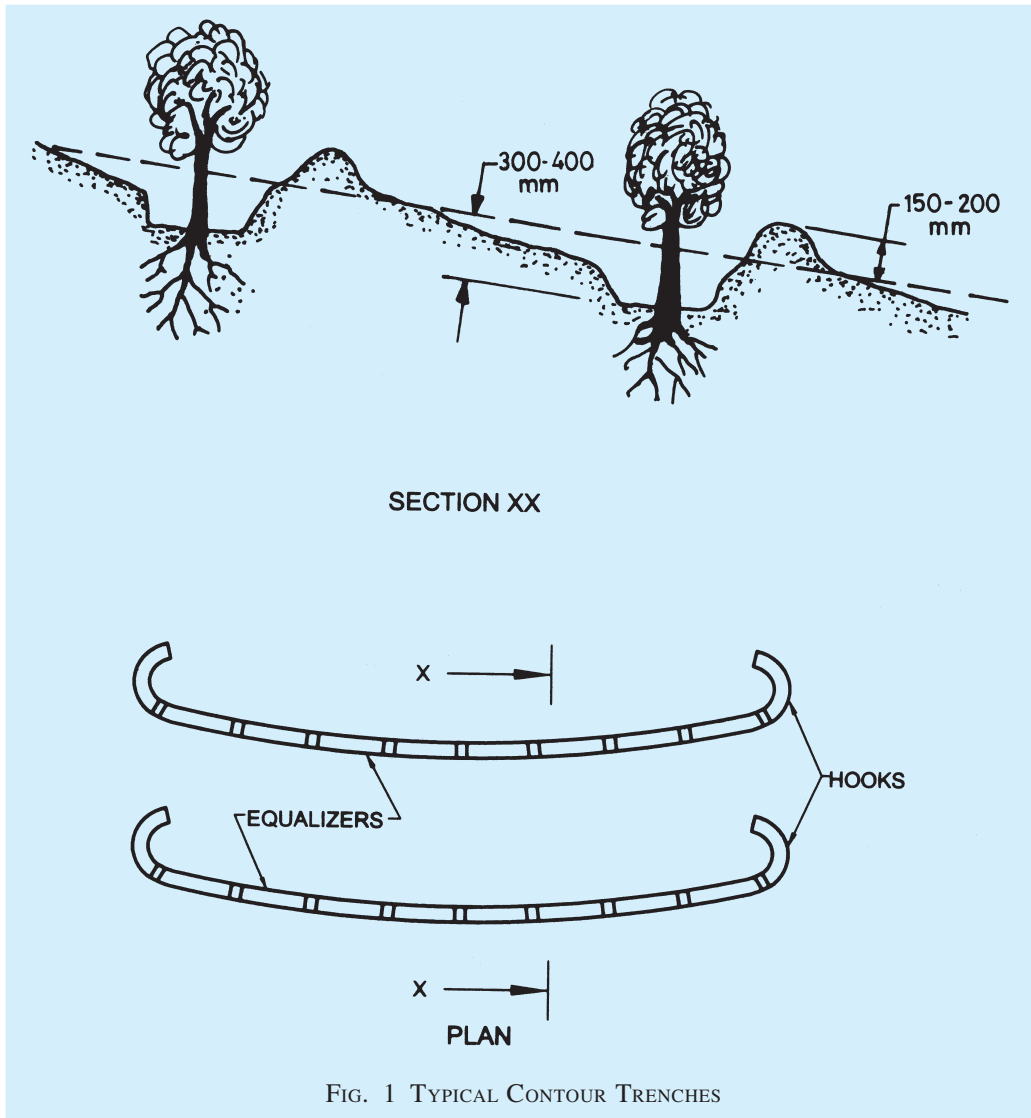

FIG. 1 TYPICAL CONTOUR TRENCHES

5.1.1 Topsoil Laying

This includes the placement of topsoil or other suitable plant material over disturbed lands to provide suitable soil medium for vegetative growth. Topsoil laying shall involve replacing fertile topsoils that were stripped and stockpiled during earlier site development activities; the laid soil shall be stabilized before the next monsoon by planting grass, shrubs and trees.

The following guidelines shall apply to the placement of topsoil:

- The existing or established grade of sub-soil should be maintained.
- A pH of 6.0 to 7.5 and organic content of not less than 1.5 percent by mass is recommended for topsoil. Where pH is less than 6.0, lime shall be applied to adjust pH to 6.5 or higher up to 7.5. Any soils having soluble salt content greater than 500 parts per million shall not be used.

- Prior to spreading the topsoil, the sub-grade shall be loosened to a depth of 50 mm to permit bonding. Topsoil shall be spread uniformly at a minimum compacted depth of 50 mm on grade of 1:3 or steeper slopes; a minimum depth of 100 mm on shallower slopes is essential. A depth of 300 mm is preferred on relatively flatter land.

5.1.2 Planting/Vegetation Cover

The most effective way to prevent soil erosion, sedimentation and to stabilize disturbed and undisturbed land is through the provision of vegetative cover by effective planting practices. The foliage and roots of plants provide dust control and a reduction in erosion potential by increasing the infiltration, trapping sediment, stabilizing soil, and dissipating the energy of hard rain. Temporary seeding shall be used in areas disturbed after rough grading to provide soil protection until final cover is established. Permanent seeding/

planting is used in buffer areas, vegetated swales and steep slopes. The vegetative cover also increases the percolation of rain-water thereby increasing the ground water recharge.

5.2 Storm Water Management and Filtration Techniques

The surface water flow is increased in urban areas due to predominance of hard surfaces. Storm water management techniques assure conservation of water thereby increasing the ground water recharge. Filters facilitate draining pollutants out from surface water runoff through straining before discharge into the drainage way. Rain-water harvesting and sullage recycle systems need to be implemented on all new constructions over 1 000 m² in urban areas (*see also* Part 9 'Plumbing Services, Section 1 Water Supply, Drainage and Sanitation').

5.2.1 Rain Water Harvesting Structures in Urban Environment

5.2.1.1 Water harvesting refers to the collection and storage of rain-water and also harvesting surface and ground water, prevention of loss through evaporation and seepage, and other hydrological and engineering interventions aimed at conserving water.

5.2.1.2 The advantages of using rain water harvesting structures in urban areas are as follows:

- a) Water harvesting recharges ground water and is an ideal solution to water problems in areas with inadequate water resources.
- b) Increase in ground water aquifer level due to methods enhancing infiltration.
- c) Mitigation of the effect of drought.
- d) Reduction of storm water runoff into the public drainage system.
- e) Reduction of flooding of the roads during monsoons.
- f) Removal of pollutants and soil from the storm water runoff.
- g) Reduction of soil erosion.

5.2.1.3 Methods of ground water recharge may be as follows:

- a) Recharge pits,
- b) Recharge trenches,
- c) Re-use of abandoned dug wells,
- d) Re-use of abandoned hand pumps,
- e) Recharge shafts,
- f) Lateral shafts with bore wells, and
- g) Spreading techniques like percolation ponds, check dams or gabion structures.

5.2.2 Structures for Rain-Water Harvesting and Soil and Water Conservation

These may be as given in 5.2.2.1 and 5.2.2.2.

5.2.2.1 Infiltration techniques

- a) *Infiltration trenches* — An infiltration trench is a rock filled trench that receives storm water runoff. Storm water passes through a combination of pre-treatment measures, a grass swale and into the trench to be stored in void spaces and then infiltrates into the soil matrix.
- b) *Bio-filtration swale/grass swale* — Bio-filtration swales are vegetated channels with a slope similar to that of standard storm drain channels (less than 0.6 percent), but wider and shallower to maximize flow residence time and promote pollutant removal by filtration through the use of properly selected vegetation. It has to be designed to trap particulate pollutants (suspended solids and trace metals), promote infiltration and reduce the flow velocity of the storm water runoff. It shall be integrated with storm water system (*see* Fig. 2).
- c) *Sand filter* — Sand filters are devices that filter storm water runoff through a sand layer into an underground drain system which conveys the water to a detention facility. They are effective in removing total suspended solids. The effectiveness of sand filtration is improved if it is preceded by a grass swale with infiltration trench.

5.2.2.2 Detention facilities

- a) *Wet ponds* — Wet ponds are constructed basins that have a permanent pool of water throughout the year (or at least throughout the wet season). Wet ponds retain the storm water runoff in a permanent pool and facilitate pollution removal through settling and biological update.
- b) *Storm water wet lands* — Storm water wet lands are structures similar to wet ponds, that incorporate wetland plants into the design. They have to be designed for treating storm water runoff, and typically have less bio-diversity than natural wetland systems. A distinction should be made between using a constructed wet land for storm water management and diverting storm water into natural wetland. The latter is not recommended because it would degrade the resource.
- c) *Wet vaults and storage tanks* — Wet vaults

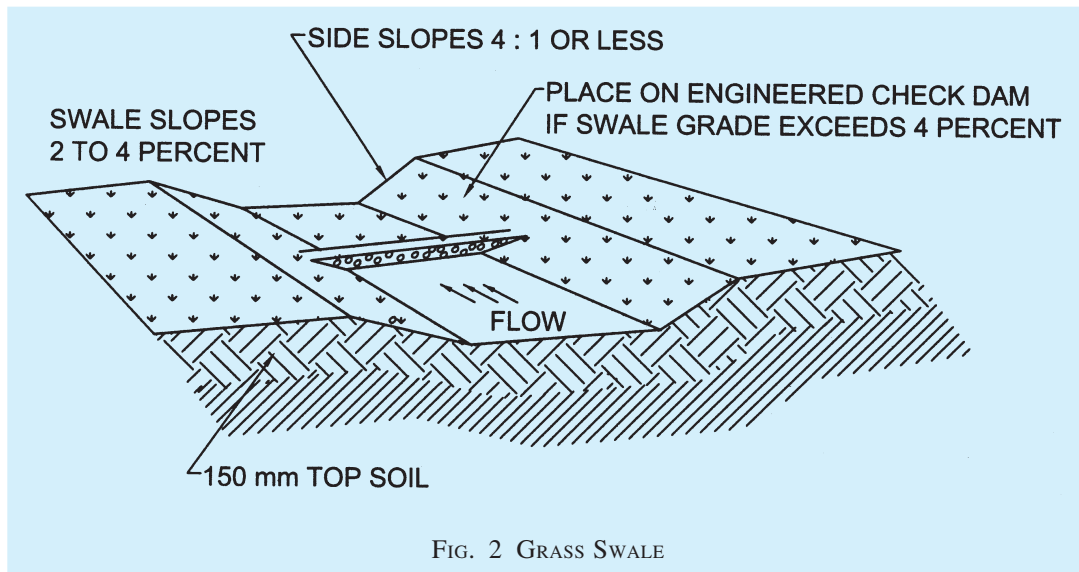

FIG. 2 GRASS SWALE

and tanks are underground facilities used for the storage of surface water, and typically constructed from reinforced cement concrete (vaults) or corrugated pipes (tanks). The water that is captured in these vaults and tanks may be used later for irrigation.

5.3 Conservation and Re-use of Water for Irrigation

The following measures shall be followed for design of irrigation systems for landscape works:

- a) Water conserving irrigation systems should differentiate between systems for different water use zones on the site. Supplementary irrigation sources should be used by means of appropriate water harvesting measures.
- b) The irrigation system should be designed considering the prevailing wind direction, slope and proposed grade, type of soil, soil percolation, and the type of vegetation to be watered.
- c) Spray irrigation to be designed to provide total head to head cover to avoid dry spots and spray on to paved areas and unplanted surfaces.
- d) Spray irrigation is to be avoided in areas of width less than 3.00 m.
- e) Sullage recycle systems are ideal for large housing complexes and residential colonies. Sullage (or water from kitchens and bathrooms) is treated and recycled for gardening and toilet flushing reducing fresh water requirement by 60 percent. Irrigation system should be designed keeping sullage recycle in view.
- f) For requirements regarding, the volume of water for different kinds of landscapes, see Part 9 'Plumbing Services, Section 1 Water

Supply, Drainage and Sanitation' may be referred.

6 EARTH SLOPES AND GRADING REQUIREMENTS

6.1 Grading Design

Design for changes in elevation in the outdoor environment is a primary component of landscape development. Grading of proposed external development areas should relate to the existing topography of the site and it should direct surface water runoff to the designed drainage and water harvesting area. Grading design parameters are as follows:

- a) The proposed grading design should respond to the function and purpose of the activities to be accommodated within the site.
- b) New development and structures to be integrated with existing landform within the site and in its immediate surroundings.
- c) Storm water to be directed away from buildings.
- d) Terraces, levels and slopes in required areas to be created and to emphasize control, or negotiate circulation routes and views.
- e) Steep slopes to be modified to minimize or eliminate erosion.
- f) Legally, grades cannot be changed beyond the property line of the site.
- g) The rate of storm water runoff leaving the site after construction to not exceed the pre-construction rate.
- h) Grading design should optimize cut and fill.

6.2 Grading Plan

6.2.1 The submitted grading plan should include the following:

- a) All existing features of the site, including all building with plinth level;
- b) Structures such as walls, walks, steps, roads, etc;
- c) Utilities such as water lines, sewer and storm water drainage, electrical lines, etc; and
- d) Utility structures like manholes, junction boxes, sewage treatment plant, septic tank, soak pit, water tanks, water treatment plant, transformers and all underground structures indicated appropriately.

Proposed features shall be indicated in firm lines and existing features in dash.

6.2.2 The grading plan should represent:

- a) General landform concept graphically represented with appropriate symbols and abbreviations (*see* 6.4).
- b) Proposed contour lines should be integrated with existing and proposed elevations within the project site.
- c) Location of swales and surface water flow, surface and sub-surface soil drainage system or water harvesting systems.
- d) Location of drainage catchments, areas of retention/detention or disposal/outfall point as the case may be.
- e) Spot grades on road, walks, and swales including top level and relevant invert levels of all utilities and utilities structures as mentioned above; critical spot elevation to be established (*see* 6.2.3).
- f) Spot elevation of building floor finish level, steps, walls, terraces and other such structures.
- g) Changes in direction or rate of slope.

6.2.3 Spot Elevations

Spot elevations shall be used to supplement contours in the following situations:

- a) To indicate variations from the normal slope or gradient between contour lines.
- b) To indicate elevations of intersecting planes and lines, like corners of buildings, walls, steps and kerbs.
- c) To indicate elevations at top and bottom of vertical elements like walls, steps and kerbs.
- d) To indicate floor and entrance elevations.
- e) To indicate elevations of high and low points.
- f) To indicate top elevations of utilities and utilities structure.

6.3 Slope Calculation

Slopes are expressed as follows:

- a) Percentage (of slope) = $\frac{\text{Vertical Rise} \times 100}{\text{Horizontal distance}}$,
for example $\frac{1 \times 100}{50 \text{ m}} = 2 \text{ percent}$
- b) Proportion (of slope) = $\frac{\text{Vertical Rise (1.0 m)}}{\text{Horizontal distance}}$,
for example 1 m in 50 m or 1:50
- c) Degree of slope, expressed as angle for example 10°, 15°, etc.

6.4 Typical Grading Symbols and Abbreviations

<i>Symbol</i>	<i>Description</i>
--(100)--	Existing contour
— 100 —	Proposed contour
(100.5)	Existing spot elevation
100.5 (Bold)	Proposed spot elevation
CB	Catch basin
FFL	Finished floor level
FGL	Finished ground level
TW/BW	Top of wall/Bottom of wall
TK/BK	Top of kerb/Bottom of kerb
HP/LP	High point/Low point
IL	Invert level

7 PLANTING DESIGN CONSIDERATIONS

Plant materials are a very important component of landscape design, and planting design is integral to the landscape plan. Designing with plants requires awareness and knowledge of a broad range of aspects including (a) ecology, (b) botany, (c) horticulture, (d) aesthetic value, (e) growth and survival, and (f) use of plants to fulfil environmental design functions.

7.1 Plant Material

The major sets of factors that influence the choice of plant material are related to the characteristics, both botanical and physical of plant material and the context in which the plant material is to be used. The inter-relationship of these sets of factors is the basis for developing a sound approach to the process of designing with plants.

7.1.1 Physical and Botanical Characteristics of Plant Material

The information on plant material should be available in a systematic format to include definition, significance and design implications of the following aspects:

- a) Nomenclature (botanical and trade-name);
- b) Origin, family and natural habitat;

- c) Growth characteristic and form as a function of habit;
- d) Physical characteristics, for example bark texture, foliage, etc;
- e) Propagation and maintenance; and
- f) Use in landscape design.

7.1.2 Vegetation Types (Evergreen and Deciduous)

Some examples of the functional implications of using evergreen and deciduous plant material for specific situations are:

- a) Evergreen trees for:
 - 1) places requiring shade throughout the year,
 - 2) strong visual screening,
 - 3) part of windbreak or shelter planting, and
 - 4) areas where leaf litter is to be discouraged.
- b) Deciduous trees for:
 - 1) greater visual variety,
 - 2) partial visual barrier,
 - 3) areas where under-planting is to be encouraged (for example grass),
 - 4) emphasis on branching and flowering pattern, and
 - 5) areas where shade is not required throughout the year.

7.1.3 Growth Rate and Age of the Vegetation

Growth rate is directly related to the life-span of a tree and slower growing trees have a life-span extending to hundreds of years. The fast growing trees to the exclusion of slower growing varieties is not recommended. Landscapes are developed to sustain future generations; slow growing long lived native trees shall be emphatically included in all major planting schemes, specially those related to institutional campuses and large urban development. However, fast growing species do have a limited role, and are appropriate in situations where:

- a) Quick effects are required, for example in windbreaks and shelterbelts.
- b) Immediate results with regards to stabilization of soil, etc are necessary, as for example, in soil conservation schemes.
- c) As 'nurse plants' to protect slower growing sensitive species when necessary.

The slower growing species would generally be appropriate in situations where sustained environmental benefits are required such as roadside planting, campuses, townships, industrial areas, and other public landscapes.

7.1.4 Growth Habits of Various Kinds of Vegetation and their Form

The overall physical form of a plant is usually the result of the foliage density and branching pattern. It may also be expressed as the proportionate relations between height and canopy spread. The latter is direct expression of growth habit.

A number of classifications of tree by their overall form exist, but it is almost impossible to have a variety according to regional conditions. The following classification into basic types may be useful:

- a) *Trees of fastigiated or columnar habit* — Examples of trees of this type are:

Casurina equisetifolia (Beet-wood)
Grevillea robusta (Silver oak)
Polyathia longifolia (Ashok)
Populus species (Poplar).

Though the branching pattern of each is different, the overall shape is similar.

- b) *Tall trees with broad canopy* — Examples of trees of this type are:

Dalbergia sissoo (Sheesham)
Tamarindus indica (Imli)
Terminalia arjuna (Arjun).

The canopy shape does not fit into any specific geometrical category.

- c) *Trees of spreading habit* — Examples of trees of this type are:

Delonix regia (Gulmohar)
Lagerstromia flosreginae (Pride of India)
Pithecolobium saman (Rain Tree).

Though these trees vary greatly in size, their basic form is similar.

- d) *Trees of weeping habit* — Examples of trees of this type are:

Callistemon lanceolatus (Bottle brush)
Salix babylonica (Weeping willow).

The above classification is helpful in choosing various combinations of the above types to achieve desired function and visual objectives.

7.1.5 Foliage Characteristics of Plant Material

Visual effects imparted by vegetation, for example, the perceived visual textures of plant forms depend on:

- a) *Leaf size and shape* — Examples of plants with large leaves and bold foliage texture are:

Alstonia scholaris (Chattin Saptorni)
Delonix regia (Gulmohar)
Jacaranda miosaefolia (Nili Gulmohar)
Plumeria acutifolia (Temple Tree)

Pterospermum acerifolium (Kanak Champa).

Leaf shape can also determine the appearance of the foliage of the plant, as for example:

Acacia auriculaeformis (Australian Black wood) — Long narrow leaves

Callistemon lanceolatus (Bottle Brush) — Narrow leaves giving a feathery appearance

Polyalthia longifolia (Ashok) — Long narrow leaves

Salix babylonica (Weeping willow) — Narrow leaves giving a feathery appearance.

b) *Leaf texture* — The textural appearance of a plant is the result of the play of light and shade on the foliage. Plants with larger leaves generally appear bolder in texture than smaller leaves plants as the areas of light and shade are larger and therefore more clearly differentiated.

c) *Leaf and foliage colour* — Most trees in India have foliage in varying shades of green with variations in colour at the time of leaf fall and at the period when the tree is newly in leaf, when the leaves are fresh and much lighter in colour. Examples are:

Lagerstroemia speciosa (Jarul) — Leaves acquire reddish tinge before falling

Polyalthia longifolia (Ashok), *Delonix regia* (Gulmohar), *Erythrina indica* (India coral tree), etc — Leaves turn yellow before falling

Ficus, intectoria (Pilkhan) Mangifera indica (Mango) etc — Young leaves have reddish tinge.

d) *Foliage density and distribution* — An important consideration is the way in which particular kinds of vegetation are perceived. Tree masses are usually seen from greater distance than shrub areas; foliage texture of different distinctive kinds of trees growing together has to be markedly distinctive for individual species to be recognizably apparent. In shrub areas subtle differences in foliage texture may suffice for creating the required visual effect.

7.1.6 Flowering Characteristics of Plant Material

7.1.6.1 Important considerations while classifying plant material according to flowering characteristics are as follows:

- a) Season,
- b) Density and distribution of flowers on the plant,
- c) Botanical characteristics of flowers (for example single/cluster, etc),
- d) Colour, and
- e) Presence or absence of foliage during flowering period.

7.1.6.2 For the purpose of understanding the visual effect of flowers, tree species may be divided into two types:

- a) Trees on which flowers appear in profusion and therefore have a very strong visual impact, for example *Delonix regia*, *Cassia fistula*, *Lagerstroemia flosreginae*.
- b) Those on which flowers are less profuse, or perhaps last for a shorter period and visual impact is more subtle, for example *Thespesia* spp., *Bauhinia* spp., etc.

An additional consideration when choosing shrubs for their flowering quality is the visual appearance of the flowers themselves, as shrubs are usually seen from quite close. Distinctive flowers are those of

- a) *Beleperone guttata* (Shrimp plant),
- b) *Hibiscus rosa-sinensis* (Climex hibiscus),
- c) *Jasminum sambac* (Chameli),
- d) *Tabernaemontana coronaria* (Cape jasmine), and
- e) *Thevetia peruviana* (Yellow oleander).

7.1.6.3 The olfactory characteristics, that is, odour, of flowers may be an added benefit of flowering plants. Flowers with distinctive scent include those of Har-singar (*Nyctanthes arbor-tristis*), Chameli (*Jasminum pubescens*), Raat Ki Rani (*Cestrum nocturnum*), etc.

7.1.6.4 Flowering characteristics of plant material may be classified as per the following format:

Botanical name	Characteristics of flower	Seasonal duration	Visual impact

7.1.7 Growth Requirement of Plant Material

Information about growth requirements of plant material applicable in landscape design pertains to the ability of particular plants to survive in specific environmental situations. These environmental conditions may arise from a number of aspects as given in 7.1.7.1 to 7.1.7.4. Capacity of plants to grow in cultivated situations is related to the environmental conditions obtaining in their natural habitat.

7.1.7.1 Soil conditions

Physical as well as chemical properties of the available soil are important. These may or may not be amenable to change, they would therefore affect the choice of plant material considerably. Physical properties include consideration of light (for example sandy) and heavy (for example clayey) soils, and their structure. Chemical properties pertain to the presence or absence of nutrients and salts; soil, alkalinity or acidity. A preliminary soil analysis is essential for implementing effective planting schemes.

7.1.7.2 Availability and quality of water

The water requirement may be derived by data of humidity and rainfall of plants natural habitat. The water table of the area where the plantation is to be done has a crucial bearing on the design with plants as well as a financial implication for reduced maintenance if planted appropriately.

7.1.7.3 Availability of sunlight

The growth rate of plants are directly related to sunlight availability; such as plants that require (a) full sunlight, (b) partial sunlight, (c) predominantly shade, and (d) complete shade.

7.1.7.4 Quality of air

Growth may be affected by chemical pollutants such as sulphur dioxide or physical pollution such as dust. Certain plants have the ability to withstand pollution, such plants are imperative for industrial areas, roads, highways, etc.

7.1.8 Maintenance

The success of a designed landscape depends upon the growth of vegetation over an extended period of time; therefore maintenance of landscape is also a design component. Maintenance needs and practices in any given situation arises out of the inter-relationship between the growth requirements of plant material chosen and the environmental conditions existing on site.

The likely degree of maintenance should be assessed based on the following:

- a) Scale of the design project,
- b) Financial and manpower resource,
- c) Availability of manures,
- d) Future intensity of site, and
- e) Environmental conditions.

In small scale projects such as gardens and small parks, the natural environmental conditions can be changed and maintained by management practices such as irrigation and application of fertilisers. The choice of

plant species is therefore not very strictly limited by the existing environmental conditions. On larger scale schemes, such as very large parks, campuses and townships, this kind of intensive maintenance may not be possible. The process of choosing plants shall therefore respond to the existing environmental conditions and also in such cases the choice of plant material is restricted by these conditions and suitable species become limited. The type of treatment adopted, as given below, may also serves as a guide to the degree of maintenance required:

a) Low Maintenance	The lowest degree of maintenance is usually possible in areas treated with native species of trees only. A slightly higher degree is necessary where native shrubs are also used, as these may require pruning.
b) Medium	Areas treated with a mixture of native and exotic trees. Exotic shrubs and trees.
c) High	Exotic shrubs and ground covers. Lawns and maintained grass areas. Annual flowers and special schemes.

7.2 Functional Aspects of Design with Plants

Plant materials in landscape design may be used to:

- a) improve existing environmental conditions with respect to soil, drainage, microclimate, air pollution;
- b) create a designed physical environment through the organization of open space; and
- c) interpret and express the contemporary understanding of the man-nature relationship, that is, design with plants on an ecological rather than horticultural basis.

7.2.1 Choosing of Plant Material

Two sets of factors influence the choice of plant material in landscape design. One relates to information about plant material itself, that determines the suitability of plant material from the point of view of growth requirements of plant material, and physical characteristics of the plant material. The second relates to the situation for which a planting proposal has to be made that pertains to the context in which the plant materials have to be used. Considerations of scale (that is, regional, local or very small scale situations), the

existing environmental conditions, and functions which the plant material has to fulfill are important. Also the level of maintenance which is likely to be kept up, has to be considered which is specially important on very large sites. The biological history and ecological need of exotic plant should be studied prior to introduction in the landscape schemes to avoid the hazard of the species that may become invasive.

The factors determining choice of plant materials may be thus summarized as follows:

- a) *Environmental conditions existing on site* — These include climatic, soil characteristics, water table, etc.
- b) *Functions which plant material has to fulfill in specific situations on a given site* — These may be either environmental functions (pertaining to improvement of soil conditions, modification or microclimate, etc) or design functions relating to creating spaces enclosure, framing views, providing visual relief, etc.
- c) *Physical characteristics and growth requirements of plant material* — The former include foliage density, foliage texture, leaf size and shape, flower colour, rooting characteristics, etc. The latter include moisture requirements, whether the plant grows in sunny or shaded conditions, etc.

7.2.2 Methodology of Design with Plants

The process for designing with plants on a given site condition may be as per the format given below:

Zone	Characteristics	Functions	Form	Species chosen	Remarks

Plant material used in landscape design may be broadly classified as:

- Tree*
 - Large
 - Medium
 - Small
- Shrub*
 - Tall
 - Low
- Ground cover*
 - Very low shrubs less than a 300 mm high

7.2.3 Functions of Plant Material

7.2.3.1 Trees

Trees perform the following functions:

- a) Protecting soil,
- b) Modifying microclimate,

- c) Shade,
- d) Habitat,
- e) Enclosure,
- f) Direction and framing views,
- g) Screening,
- h) Visual relief, and
- j) Ornamental.

NOTE — For functions of plants/shrubs to reduce noise, 3.6 of Part 8 'Building Services, Section 4 Acoustics, Sound Insulation and Noise Control' may be referred.

7.2.3.2 Shrubs

The functions are similar to those of trees. Shrubs may be used together with trees to reinforce the functions, for example, noise barrier, shelter belts, enclosures, etc.

Other forms in which shrubs may be used are:

- a) *Hedges* — These require regular maintenance
- b) *Shrubbery* — Here plants are allowed to retain their natural shape; they therefore require little maintenance.

Shrubs provide barriers, which may either be visual or physical (hedges). Barriers may be required in a range of situations, for example they may be only for defining space, or they may be required for security and have to be, therefore, necessarily impenetrable.

7.2.3.3 Ground cover

Ground cover plants are those which naturally grow to a very low height. Some of the uses for which they may be used are:

- a) Stabilizing soil on steep slopes such as embankments.
- b) As a low maintenance substitute for grass (where the surface is not to be used).
- c) For providing variety in surface treatment.
- d) Contrast with paving materials, for example to soften rigid lines of paving.
- e) As a subtle means of demarcating space, as for example, in places where tall plants would be visually intrusive.
- f) In combination with other plants to provide contrast or harmony in form.

7.2.3.4 Climbers

Certain climbers because of their spreading habits may also be used as ground cover (for example *Asparagus* spp.) Climbers are useful for shading exposed walls from direct sunlight. They may also be used for stabilizing soil on embankments (for example, *Ficus stipulata*, *Ipomea biloba*). On sites where a high degree of security makes fencing necessary, climbers and

spreading plants like *Bougainvillea species*, may be trained on boundary wall.

7.3 Planting for Shelter and Soil Conservation

The use of vegetation for controlling wind is widely recognized as an effective way of conserving soil and reducing erosion by wind. Vegetation may therefore be used for modifying the microclimate, by obstructing, guiding, deflecting or filtering wind current.

Vegetation areas designed to fulfill these general functions are usually classified as windbreakers and shelterbelts. Windbreaker is grown protective planting around gardens and orchards. Windbreakers generally consist of single or double row of trees. Shelterbelt provides an extensive barrier of trees with several rows of trees. Plant species are chosen with particular regard to their physical and growth characteristics, and their effectiveness in achieving the desired results. Both windbreakers and shelterbelts have considerable visual impact in the landscape in which they are situated, they therefore need to be designed so that they make a positive visual and aesthetic contribution to their environment.

7.3.1 Function

Windbreakers and shelterbelts fulfill essential micro-climatic functions in rural and urban environments. Benefits accruing from plantation of shelter planting may be as follows:

- a) Reduction in wind velocity resulting in the arrest of movements of sand and soil particles.
- b) Prevention of soil erosion.
- c) Modification of micro-climate; moderation of change in air temperature.
- d) Protection of crops from being blown by high winds.
- e) Protection of livestock.
- f) Reduction in evaporation of soil moisture. Increase in soil moisture content varies from 3 percent to 7.8 percent. Water loss due to evaporation is lessened.
- g) Increase in soil moisture due to greater dewfall in sheltered areas has been found to be 200 percent higher than on exposed ground; heaviest dew fall is over a distance of 2 to 3 times the height of the shelterbelt.
- h) Beneficial effect on growth of plants that are affected by high winds.
- j) Extensive shelterbelts may also be used to augment the supply of fuel in rural areas.
- k) The zone of influence of shelterbelt on crop

yield extends to a distance of 20 times the height of the belt, with the maximum effect being observed 10 times the height of the tree belt, on the leeward side.

7.3.2 Wind Erosion

Some of the basic functions of windbreaks and shelterbelts in arid and semi-arid areas are to conserve soil and reduce erosion by wind (*see 7.3*). The latter is a natural phenomenon in lands having very little rainfall (125 mm-250 mm) and in areas adjoining a river, lake or sea. Wind erosion is a serious problem in areas where the ground is virtually bare and devoid of vegetation.

Factors which influence the degree and kind of wind erosion are as follows:

- a) *Features of wind* — Speed, direction, temperature, humidity, burden carried, etc.
- b) *Character of surface* — Rough or smooth plant cover, obstruction, temperature, etc.
- c) *Topography* — Flat, undulating broken, etc.
- d) *Character of soil* — Texture, organic matter, moisture content, etc.

7.3.2.1 Techniques for control of wind erosion

The principal method of reducing surface velocity of wind, upon which depends the abrasive and transportation capacity of wind, is by vegetation measures. Vegetation methods are found to be most effective in the form of windbreaks and shelterbelts. In aerodynamic terms, these provide protection as follows:

- a) Sheltered zone on the leeward side extends to approximately 15-30 times the height of the belt.
- b) A dense belt provides greater shelter immediately to leeward side but the sheltered area is not as extensive as when a more permeable zone of vegetation is provided.
- c) Porosity is important in the effectiveness of shelterbelt and proper selection of tree species is necessary. Porosity near ground level is desirable.
- d) Effectiveness of shelter planting depends more on height and permeability than on width. The width influences the general microclimate but above a certain minimum width, it does not effect greater reduction in wind velocity.

Protection obtained varies in relation to height (H) of shelterbelts, as given below:

<i>Distance</i>	<i>Wind Reduced by</i> (in percent)
<i>H</i>	90
<i>2H</i>	75
<i>5H</i>	50
<i>10H</i>	20

This indicates that it is better to have several windbreaks *5H* to *6H* apart rather than large forest stands with wide open spaces in between.

7.3.3 Profiles

A belt which rises and falls abruptly on windward and leeward sides is said to be more effective. Smaller trees and shrubs should occupy the inter-spaces between the tall tree.

NOTE — Some authorities maintain that triangular section of shelterbelt planting is more effective.

The depth of the shelterbelt should be approximately ten times its height. This is, however, only a thumb rule. Much lesser widths of 20 m to 30 m have also been found to be useful in particular situations; 15 m should be considered as minimum width.

Apart from factors such as climate, soil, fast rate of growth, one of the more significant considerations in choosing species for shelter planting is the possibility of a particular species serving the dual role of wood-production (for fuel, fodder) as well as shelter.

7.3.3.1 Spacing of plants in windbreaks and shelterbelts

Windbreaks usually consist of a single or double row of trees planted at 0.7 m to 1.5 m according to species. Normally, one year old trees are used. As the roots of tree extend for some distance beyond the rows in which they are planted, the same should be taken into account while planting windbreakers. The most common layout where shelter planting is part of an extensive planned programme, is that of tree belts arranged in a chessboard pattern, each field being-protected from every side. This pattern gives full protection to all the fields, provided that the right distance between the fields has been chosen. Efficient protection is achieved if belts are separated by a distance of not more than 20 times the height of the trees. A considerable mixture of species is recommended so as to compensate for different rates of growth and also to achieve variety in the form of crowns.

7.3.3.2 Within shelterbelts, close spacing of tree is the general practice. The recommended spacing for shrubs is 1 m and for tree such as *Casuarina* and *Grevillia robusta* (*Silver Oak*) 2.5 m. Spacing between rows should be 2.3 m to 3 m to enable mechanized cultivation. Five rows of tree and shrubs are considered necessary for protection.

7.3.4 Management

Shelterbelts should be regarded as living groups of trees to be managed in perpetuity and the following shall be taken into consideration for management thereof:

- Thinnings are limited to a strict minimum.
- Cutting is done individually by single tree selection method.
- Continuous cultivation may be required in areas with scanty rainfall.
- If individual trees do not survive, they should be replaced immediately to avoid gaps in the vegetation belt. The shelterbelt should be protected from cattle, either by fencing or other means, specially in the early stages.

The location of shelterbelt may be related to local features such as public and private road networks, buildings, irrigation and water conservation works and methods soil management practice (contour bunding, contour cultivation etc). Careful choice of site will provide maximum protection to adjacent land and give shelter and shade.

The application of the concept of shelterbelts to landscape planning and design may be effective in the creation of landscape structure of very large developments at the regional scale, or townships or campuses. Shelterbelts can also be established in association with, or instead of road side planting. This itself creates a distinctive landscape pattern. The advantage of using native species in shelter planting are:

- New development is merged into the existing landscape. The original character of the landscape is therefore not obtruded upon.
- The shelterbelt is a component of land management (previous waste or barren land is conserved).
- Additional habitat for wildlife are brought into existence.

7.3.5 Species-suitable for wind breaks are:

- For Dry and Arid Regions*
Acacia auriculiformis (Australian Blackwood)
Ailanthus excelsa (Maharukh)
Albizia lebbek (Siris)
Azadiracta indica (Neem)
Casuarina equisetifolia (Beef-wood)
Dalbergia sissoo (Sisham)
Eugenia jambolana (Jamun)
Grevillea robusta (Silver oak)
Peltophorum ferrugineum (Cooper pod)
Tamarindus indica (Imli)

- Pongamia glabra* (Indian beech)
- Tamarix articulata* (Tamarisk)
- b) *For Coastal Area*
 - Anacardium occidentale* (Cashu)
 - Ailanthus malabarica* (Alston)
 - Cassuarina equisetifolia* (Beef-wood)
 - Pongamia glabra* (Indian beech)
 - Sesbania aculeate* (Sesban)
 - Thevetia peruvian* (Yellow oleander)
 - Thespesia populnea* (Indian Tulip)
 - Vitex negundo* (Sephali)

7.4 Air Pollution Control by Plants

Air pollution may be caused by areas or point sources such as cities, industrial areas, factories or by linear sources such as highways. Vegetation buffers can minimize the build-up of pollution levels in urban areas, by acting as pollution sinks.

Studies have established that air pollution, smoke and sulphur dioxide leads to an exacerbation of chronic respiratory diseases and they are linked to lung cancer, pneumonia, tuberculosis, chest disease in children, stomach cancer and cardiovascular diseases. Lead from vehicle exhausts may have an adverse effect on mental health of children, asbestos from disintegrating clutch and brake linings has been considered as a causal factor in lung cancer.

7.4.1 Effect of Plants

Plant leaves function as efficient gas exchange systems. Their internal structure allows rapid diffusion of water-soluble gases. These characteristics allow the plant to respire and photosynthesise, and they can also remove pollutant from the air. Some of the beneficial results of plantations may be:

- a) They are good absorbers of sulphur dioxide.
- b) Parks with trees have an SO₂ level lower than city streets.
- c) Roadside hedges can reduce traffic generated air borne lead, on leeward side.
- d) Heavy roadside planting in the form of shelterbelts can result in a reduction in airborne lead.
- e) Complete dust interception can be achieved by a 30 m belt of trees. Even a single row of trees may bring about 25 percent reduction in airborne particulate.

7.4.2 Choosing Plants

The three main criteria for selection of plants may be:

- a) Tree, shrubs should have a dense foliage with a large surface area, because leaves absorb pollutants.

- b) Evergreen trees are found to be more effective.
- c) The species chosen must be resistant to pollutants, particularly in the early stages of their growth.

The following species may be examined for their likely potential for pollution control:

- Acacia arabica* (Babul)
- Citrus species*
- Dyospyros species
- Ficus bengalensis* (Banyan)
- Ficus religiosa* (Peepal)
- Lilium* spp. (Lily)
- Polyalthia lotigifolia* (Ashok)
- Tamarindus indica* (Imli)
- Thuja occidentalis* (Cedar)
- Prosopis Juliflora* (Mesquite)
- Zizypus jujuba* (Jujuba), etc.

Filtering of pollutants is most effective when plants are close to the source of pollution. The design of shelterbelts against pollution is similar to those for protection from wind. They should be permeable to encourage air turbulence and mixing within the belt. There should be no large gaps. The profile should be rough and irregular and should present a tall vertical leading edge to the wind. Spaces should be left within the shelterbelt to allow gravity settlement of particles.

7.4.3 Applications

Air pollution shelterbelts may be used to protect sensitive land uses from air pollution. For instance school playgrounds, children play area and residential estates close to major roads may be so protected. Shelterbelt protection may also be provided for hospitals, institutions, etc, where the vegetation may also be a visual screen and a partial noise barrier. Vegetation may also be used where the existing means of pollution control have proved inadequate.

8 SPECIFICATIONS FOR PLANTING WORKS

The requirements relating to plant materials and other materials; execution of work of tree planting, shrub planting and grassing; maintenance; etc shall be as given in 8.1 to 8.6. The contractor shall furnish all materials, labour and related items necessary to complete the work indicated on drawing and specified herein and shall carry out maintenance of the premises for 12 months after completion of the work or as specified by the landscape architect.

8.1 Materials

8.1.1 Plant Materials

Plant materials shall be well formed and shaped true

to type, and free from disease, insects and defects such as knots, windburn, injuries, abrasion or disfigurement. All plant materials shall be healthy, sound, vigorous, free from disease, insect pests, or their eggs, and shall have healthy, well-developed root systems. All plants shall be hardy under climatic conditions similar to those in the locality of the project. Plants supplied shall conform to the names listed on both the plan and the plant list. No plant material will be accepted if branches are damaged or broken. All material shall be protected from sun and adverse weather until planted. Nursery stock shall be inspected and approved by the landscape architect and the horticulturist/botanist shall do the botanical authenticity of the selected species.

All plants shall conform to the requirements specified in the plant list, except those plants larger than specified may be used if approved, but use of such plants shall not increase the contract price. If the use of the larger plant is approved, the spread of roots or ball of earth shall be increased in proportion to the size of the plant. Plants shall be delivered with legible identification labels.

The minimum acceptable size of all trees after pruning, with branches in normal positions, will conform to the measurement specified in the bill of quantities unless stated otherwise. Caliper measurement will be taken at a point on the trunk 1.0 m above natural ground. All trees supplied shall have terminal shoots. All specimen trees shall have a minimum crown spread of not less than half the size of the overall height.

8.1.2 Topsoil (Good Earth) with pH Range between 6.5 to 7.5

Topsoil or good earth shall be a friable loam; typical of cultivated top soils of the locality contains at least 2 percent of decayed organic matter (humus). It shall be taken from a well-drained arable site. It shall be free of sub-soil, stones, earth clods, sticks, roots or other objectionable extraneous matter or debris. It shall contain no toxic material. No topsoil shall be delivered in a muddy condition.

8.1.3 Fertilizer

Dry farm yard manure shall be used. Measurement shall be in stacks, with 8 percent reduction for payment. It shall be free from extraneous matter, harmful bacteria insects or chemicals.

8.1.4 Root System

The root system shall be conducive to successful transplantation. Where necessary, the root-ball shall be preserved by support with hessian or other suitable material. On soils where retention of a good ball is not possible, the roots should be suitably protected

in some other way which should not cause any damage to roots.

8.1.5 Condition

Trees and shrubs shall be substantially free from pests and diseases, and shall be materially undamaged. Torn or lacerated roots shall be pruned before dispatch. No roots shall be subjected to adverse conditions, such as prolonged exposure to adverse conditions, such as prolonged exposure to drying winds or subjection to waterlogging, between lifting and delivery.

8.1.6 Marking

Each specimen of tree and shrub, or each bundle, shall be legibly labelled with the following:

- a) Its name.
- b) Name of the supplier, unless otherwise agreed.
- c) Date of dispatch from the nursery.

8.2 Execution

8.2.1 Fine Grading

Grades will be smooth and even on a uniform plane without abrupt changes or pockets and slope away from the buildings. The nominated landscape contractor will verify the surface drainage of planting areas and notify the landscape architect of any discrepancies, obstructions or other conditions considered detrimental to proper execution of the work and plant growth.

8.2.2 Landscape work will be tied to the existing condition such as existing trees palms, landscape features, utility lines, pavement kerbs, etc. Finished grade will bear proper relationship to such control. The nominated landscape contractor shall adjust all works as necessary to meet the conditions and fulfill the intention of the drawings.

After initial settlement the finish grade will be:

- a) *Turf*: 20 mm lower than adjacent walks/kerbs.
- b) *Shrubs and Ground covers*: 40 mm lower than adjacent walks/kerbs.

Prior to planting operation, the contractor will ensure all planting areas free of weeds, debris, rocks over 25 mm in diameter and clumps of earth that do not break up.

8.3 Tree Planting

8.3.1 Trees should be supplied with adequate protection as approved. After delivery, if planting is not to be carried out immediately, balled plants should be placed cheek to cheek and the ball covered with sand to prevent drying out. Bare rooted plants can be

heeled in by placing the roots in a prepared trench and covering them with earth which should be watered in to avoid air pockets round the roots.

8.3.2 Digging of Pits

Tree pits shall be dug a minimum of three weeks prior to backfilling. The pits shall be 1 200 mm in diameter and 1 200 mm deep. While digging the pits, the topsoil up to a depth of 300 mm may be kept aside, if found good (depending upon site conditions), and mixed with the rest of the soil. If the soil is bad below, it shall be replaced with the soil mixture as specified further herein. If the soil is normal it shall be mixed with manure; river sand shall be added to the soil if it is heavy.

8.3.3 Flooding of Pits to Reduce Air Pockets

The soil backfilled, watered through and gently pressed down, a day previous to planting, to make sure that it may not further settle down after planting. The soil shall be pressed down firmly by treading it down, leaving a shallow depression all round for watering.

8.3.4 Planting

No tree pits shall be dug until final tree positions have been pegged out for approval. Care shall be taken that the plant sapling when planted is not buried deeper than in the nursery, or in the pot. Planting should not be carried out in waterlogged soil.

Trees should be planted up to the original soil depth; the soil marks on the stem is an indication of this and it should be maintained on the finished level, allowing for setting of the soil after planting. All plastic and other imperishable containers should be removed before planting. Any broken or damaged roots should be cut back to sound growth.

The bottom of the planting pit should be covered with 50 mm to 75 mm of soil. Bare roots should be spread evenly in the planting pit; and small mound in the centre of the pits on which the roots are placed will aid an even spread. Soil should be placed around the roots, gently shaking the trees to allow soil particles to shift into the root system to ensure close contact with all roots and to prevent air pockets. Back fill soil should be firm as filling proceeds, layer by layer, care being taken to avoid damaging the roots.

8.3.5 Staking

Newly planted trees shall be held firmly although not rigidly by staking to prevent a pocket forming around the stem and newly formed fibrous roots being broken by mechanical pulling as the tree rocks.

The main methods of staking shall be:

- a) A single vertical stake, 900 mm longer than

the clear stem of the tree, driven 600 mm to 900 mm into the soil.

- b) Two stakes as above driven firmly on either side of the tree with cross-bar to which the stem is attached (suitable for small bare-rooted or balled material).
- c) A single stake driven in at an angle 45° and leaning towards the prevailing wind, the stem just below the lowest branch being attached to the stake (suitable for small bare-rooted or balled material).

The end of stake should be pointed and the lower 1 m to 1.2 m should be coated with non-injurious wood preservative allowing at least 150 mm above ground level.

8.3.6 Tying

Each tree should be firmly secured to the stake so as to prevent excessive movement. Abrasion shall be avoided by using a buffer, rubber or hessian, between the tree and stake. The tree should be secured at a point just below its lowest branch, and also just above ground level; normally two ties should be used for tree. These should be adjusted or replaced to allow for growth.

8.3.7 Watering

The contractor should allow for the adequate watering in all newly planted trees and shrubs immediately after planting and shall, during the following growing season, keep the plant material well watered.

8.4 Shrub Planting in Planters and Beds

8.4.1 All areas to be planted with shrubs shall be excavated, trenched to a depth of 750 mm, refilling the excavated earth after breaking clods and mixing with manure in the ratio 8:1 (8 parts of stacked volume of earth after reduction by 20 percent; 1 part of stacked volume of manure after reduction by 8 percent).

Tall shrubs may need staking: which shall be provided if approved by the landscape architect depending upon the conditions of individual plant specimen.

For planting shrubs and ground cover shrubs in planters, good earth shall be mixed with manure in proportion as above and filled in planters.

Positions of shrubs to be planted should be marked out in accordance with the planting plan. When shrubs are set out, precautions should be taken to prevent root drying. Planting holes 400 mm in diameter and 400 mm deep should be excavated for longer shrubs. Polythene and other non-perishable containers should be removed and any badly damaged roots carefully pruned. The shrubs should then be set in holes so that the soil level, after settlement, will be at the original

soil mark on the stem of the shrub. The hole should be back-filled to half its depth and firmed by treading. The remainder of the soil may then be returned and again firmed by treading.

8.5 Grassing

8.5.1 Preparation

During the period prior to planting the ground shall be maintained free from weeds. Grading and final levelling of the lawn shall be completed at least three weeks prior to the actual sowing. Regular watering shall be continued until sowing by dividing the lawn area into portions of approximately 5 m² by constructing small bunds to retain water. These bunds shall be levelled just prior to sowing of grass plants. At the time of actual planting of grass, it shall be ensured that the soil has completely settled.

8.5.2 Soil

The soil itself shall be ensured to the satisfaction of the landscape architect to be a good fibrous loam, rich in humus.

8.5.3 Sowing the Grass Roots.

Grass roots shall be obtained from a grass patch, seen and approved beforehand. The grass roots stock received at site shall be manually cleared of all weeds and water sprayed over the same after keeping the stock in a place protected from sun and dry winds. Grass stock received at site may be stored for a maximum of three days. In case grassing for some areas is scheduled for a later date fresh stock of grass roots shall be ordered and obtained. Small roots shall be dibbled about 75 mm apart into the prepared grounds. Grass areas will only be accepted as reaching practical completion when germination has proved satisfactory and all weeds have been removed.

8.5.4 Maintenance

As soon as the grass is approximately 30 mm high it shall be rolled with a light wooden roller in fine, dry weather — and when it has grown to 50 mm to 80 mm above ground, weeds shall be removed and regular cutting with the scythe and rolling shall be begun. A top-dressing of farm yard manure, bone meal at the rate of 50 g/m² and NPK at the rate of 10 g/m² shall be applied when the grass is sufficiently secure in the ground to bear the mowing machine, the blades shall be raised 25 mm above the normal level for the first two or three cuttings. That is to say, the grass should be cut so that it is from 40 mm to 50 mm in length, instead of the 30 mm necessary for mature grass.

In the absence of rain, in the monsoon the lawn shall be watered with sprinklers every, three days soaking the soil to a depth of at least 200 mm. Damage, failure

or dying back of grass due to neglect of watering specially for seeding out of normal season shall be the responsibility of the contractor.

Any shrinkage below the specified levels during the contract or defects liability period shall be rectified at the contractor's expense. The contractor shall exercise care in the use of rotary cultivator and mowing machines to reduce to a minimum the hazards of flying stones and brickbats. All rotary mowing machines are to be fitted with safety guards.

8.5.5 Rolling

Lawn mower with roller shall be used periodically, taking care that the lawn is not too wet and sodden.

8.5.6 Edgings

These shall be kept neat and shall be cut regularly with the edging shears.

8.5.7 Watering

Water shall be applied at least once in three days during dry weather. Water whenever done should be thorough and should wet the soil at least up to a depth of 200 mm.

8.5.8 Weeding

Prior to regular mowing the contractor shall carefully remove rank and unsightly weeds.

8.6 Maintenance

8.6.1 The landscape contractor shall maintain all planted areas within the landscape contract boundaries for one year until the area is handed over in whole or in phases. Maintenance shall include replacement of dead plants, watering, weeding, cultivating, control of insects, fungus and other diseases by means of spraying with an approved insecticide or fungicide, pruning, and other horticulture operations necessary for the proper growth of the plants and for keeping the landscape contract area neat in appearance.

8.6.2 Pruning and Repairs

Upon completion of planting work under the contract all trees should be pruned and all injuries repaired where necessary. The amount of pruning shall be limited to the minimum necessary to remove dead or injured twigs and branches and to compensate for the loss of roots and result of transplanting operations.

Pruning and removal of any part of plant materials should be done with clean sharp tools. Tools used to carry out the pruning work shall be appropriate for the task. The surface of tools and equipment will be sterilized after use on the plant materials that are suspected or known to be diseased. Cuts on plant materials shall be made into the living tissues to induce

callousing. Cut surface will be flat, sharp and without jagged or torn edges.

Pruning shall be done in such a manner as not to change the natural habitat or special shape of the trees. Pruning operation will consider carefully the natural growth pattern of branches on the tree, palm or shrub. Tree branches will be pruned back to the collar at the base of the branch.

8.6.3 Tree guards

Where tree guards are necessary, care should be taken to ensure that they do not impede natural movement or restrict growth.

8.6.4 Nursery Stock

Planting should be carried out as soon as possible after reaching the site. Where planting needs to be delayed, care should be taken to protect the plants from pilfering or damage from people or animals. Plants with bare roots should be heeled-in as soon as received or otherwise protected from drying out, and others set closely together and protected from the wind. If planting needs to be delayed for more than a week, packed plants should be unpacked, the bundles opened up and each group of plants heeled-in separately and clearly labelled. If for any reason the surface of the roots becomes dry the roots should be thoroughly soaked before planting.

8.6.5 Protective Fencing

According to local environment shrubs shall be protected adequately from vandalism until established.

8.6.6 Routine Maintenance Work Schedule

Operation	Frequency
i) Watering	Checking all planting areas and pits and water as often as necessary to ensure that planting material does not dry out
ii) Weeding	Monthly
iii) Edging	Monthly
iv) Fertilizing	
a) Trees/palms	Once every three months
b) Shrubs/ground covers	Monthly
c) Grass	Once every three months
v) Loosening of soil	Monthly
vi) Control of pest by applying appropriate insecticides	Fortnightly
vii) Control of disease by applying appropriate fungicides.	Monthly, increasing the frequency to fortnightly during rainy season

Operation	Frequency
viii) Grass cutting	Fortnightly
ix) Pruning and shaping trees/palms	Once every six month for small and low sagging branches
x) Staking	As and when required.
xi) Trimming shrubs/ground covers	Monthly or as when required

8.6.7 Clean-Up Works

There shall be areas designated by landscape architect for the contractor to carry out clean-up works. These shall include the following:

- a) Removal of dead and/or overhanging branches of existing trees, palms, shrubs and groundcovers.
- b) Removal of any garbage and unsightly foreign materials.
- c) Removal of dead vines and plant materials.

The contractor shall prevent damages to the existing plant materials, identified to be conserved. The plant materials that are to be conserved if damaged beyond use during the clean-up operations, the contractor shall be liable to replace the plant materials at their own expense.

8.6.8 Restoration

The contractor is responsible for the use of all materials, labour and equipments and any injury to the plant material, labour and equipment will be repaired or the same replaced by the contractor at his own expense.

8.6.9 Completion

On completion, the ground shall be formed over and left tidy.

9 SERVICE UTILITIES IN LANDSCAPE

9.1 Designed integration of structures and elements related to external services (underground and over ground utilities) with landscape is most essential for any outdoor space.

The following services generally are the subject of design co-ordination work for external areas:

- a) Storm water drainage
 - 1) Storm water network;
 - 2) Open drain and swale;
 - 3) Subsurface drainage system;
 - 4) Catch basin and manholes;
 - 5) Culvert and bridge;
 - 6) Percolation pits;
 - 7) Water harvesting units;
 - 8) Retention walls and tanks;

- 9) Connection of all service lines up to out-fall; and
- 10) Other related structures.
- b) *Sewage disposal system*
 - 1) Sewerage network;
 - 2) Manholes, inspection chambers and grease trap;
 - 3) Septic tank, soak-pits, sewage treatment plant and root zone unit;
 - 4) Solid waste management units;
 - 5) Connection of all service lines up to out-fall; and
 - 6) Other related structures.
- c) *Water supply*
 - 1) Water supply network;
 - 2) Inspection chamber and valve chamber;
 - 3) Water tank and treatment plant;
 - 4) Tube well, bore well and associated pump houses, etc; and
 - 5) Service lines, elements associated with water features and pools.
- d) *Fire lines*
 - 1) Yard hydrant lines;
 - 2) Yard or fire hydrants and hose reel box;
 - 3) Fire water tank and pumps; and
 - 4) Inspection chamber and valve chamber.
- e) *Electrical works*
 - 1) Electrical network;
 - 2) Light fixtures for road, pedestrian paths; special landscape features and building facade;
 - 3) Inspection chambers, junction boxes and feeder pillars;
 - 4) Electric poles, high voltage lines and towers;
 - 5) Transformer, substation and distribution box; and
 - 6) Other related structures.
- f) *Telephone and under ground cable network*
 - 1) Telephone network;
 - 2) Inspection chambers;
 - 3) Telephone poles, transmission towers; and
 - 4) Other related structures.
- g) *Fuel and gas line*
 - 1) Supply network;
 - 2) Inspection chamber and valve chamber;
 - 3) Fuel tank and gas tank; and
 - 4) Other related structures.

designed integration of external services networks and elements in the landscape proposal:

- a) The manholes and inspection chamber covers for all external services should be adequately designed for the live load (pedestrian or vehicular) and the top finish level has to be in alignment or flushed with the pavement or finished ground level. The alignment of these structures should be such that it is in geometric perpendicular or parallel with adjacent building or landscape lines. This would facilitate easy and unobstructed movement for pedestrians and increase the accessibility for wheelchair users in public place and also aid the landscape geometry to be maintained.
- b) Fire hydrants should be prominently located and integrated with the landscape. Aesthetically designed fire hose cabinet with clear access as per statutory norms for fire safety, to be located in geometric relation with adjacent building or landscape lines. These structures should not be a hindrance to vehicular or pedestrian movement.
- c) Irrigation hydrants should be unobtrusively located and generally at the edge of shrub planting and additionally in close proximity to a drainage chamber or catch basin to avoid waterlog. Hydrants should not be located inside the chamber to minimize waterlog from leaking pipes causing various health related hazards. Hydrants should be located 200 mm above the ground level.
- d) Landscape lighting is a specialized activity and illumination consultant or designer should develop the landscape lighting plan taking into consideration energy saving measures, safety aspects, lighting pollution and illumination level. Light fixtures are an important part of street furniture and it is advisable to use pole mounted light fixtures for public landscape than bollards that are prone to vandalism and damage.
- e) Water body and fountains in public spaces should have filtration facility to avoid health hazards related to stagnant water. The piping should be concealed and the pump room, balancing tank and all other service structures to be designed as an integral part of landscape.
- f) Storage facilities for inflammable liquid fuel and gas should be designed as a integral part of the landscape and should be housed in designed enclosures taking into consideration all statutory norms these structures are subjected to.

9.1.1 The following guidelines shall be applied for the

- g) All underground service lines have to be well coordinated and stacked appropriately in the design stage to avoid overlaps and marked with indicators above the ground for ease in maintenance and servicing. Underground service stacks should be generally aligned in soft areas with no tree plantation, this would facilitate easy maintenance without disrupting the hard surface.
- h) Designed façade for service structures that are above the ground in external areas is advisable so as to assist in developing aesthetically pleasing exterior environment. Such structures should be designed in a modular way so that it would be part of the street furniture.

10 PAVED SURFACES IN EXTERNAL AREAS

The paved areas that are used for movement of vehicles, pedestrians, and wheel chair users in outdoor environment have to be designed to facilitate easy accessibility, with well drained surface, and good visual clues achieved with varied colour and texture of finishing materials. The following guidelines may be applied for the design of paved outdoor spaces:

- a) Roads should provide clear access to fire fighting vehicles, ambulance, sanitation vehicles, etc and also allow safe movement for vehicles, pedestrians and wheel chair users.
 - b) Kerbs are required on all roads to adequately control drainage within the road, prevent moisture from entering the sub-grade, separate the road from the pedestrian area, and provide adequate lateral support for the pavement structure.
 - c) Pedestrian circulation path consists of sidewalks, wheelchair ramp, and landings. Pathways of minimum width 1.50 m are required along the length of road for any public or private building where pedestrian traffic is expected.
 - d) Path way should be physically separated by means of kerb, graded separation, barrier, railing, or other means. The cross slope of sidewalk will not exceed two percent. The longitudinal slope of path should not exceed 1 in 20, unless the longitudinal slope of the road exceeds this maximum, in that case the standards that conform to a ramp should be applied.
 - e) Benches, shelters, poles, signs, bus stops, etc should be located on edge of the sidewalk with clear minimum width of 1.20 m for circulation path.
- f) All ramps should have minimum width of 1.20 m, excluding edge protection. The cross slope of ramp should not exceed 1 in 50. And longitudinal slope of ramp should not exceed 1 in 12. All ramps should have an unobstructed level landing both at top and bottom of the ramp. The landing should have the minimum width as the ramp. The landing should be minimum 1.50 m in length. Any ramp beside the road should be located in such a way so that vehicles cannot park blocking the access.
 - g) Handrail would be required for any ramp with greater vertical height than 300 mm to prevent pedestrians and wheelchair users slipping from the ramp. The height of the top handrail should be 900 mm from the top surface of the ramp. The ramp surface should be rough finished. All ramp and landing should be designed so that water does not collect on the surface of the ramp or landing.
 - h) Stone not less than 40 mm in thickness should be used as paving finish in external areas. Adequate slope and drainage facility to be considered for all external paved surface integrating it with the pavement design.
 - j) Smooth finish is not recommended for external areas except to convey any design concept.
 - k) Change in levels and steps may be depicted in different texture or colour as a visual clue.

11 STREET FURNITURE

The design elements for outdoor spaces may be classified under the following categories:

- a) *Pavement and other pedestrian movement spaces, covering*
 - 1) Footpath with heavy pedestrian traffic,
 - 2) Footpath with light pedestrian traffic,
 - 3) Plaza and public assembly spaces,
 - 4) Kerb to footpath, and
 - 5) Steps and ramps.
- b) *Parking and vehicular movement corridor, covering*
 - 1) Parking unit,
 - 2) Median and road divider,
 - 3) Road marking, and
 - 4) Speed breaker.
- c) *Traffic management units, covering*
 - 1) Bollards,
 - 2) Barriers,

- 3) Crash guard,
- 4) Gate/Access control,
- 5) Vehicular height restrictors, and
- 6) Traffic separators.
- d) *Outdoor public conveniences, covering*
 - 1) Seating,
 - 2) Drinking fountains, and
 - 3) Toilet/Wash rooms.
- e) *Shelter and kiosks, covering*
 - 1) Bus shelters,
 - 2) Police booth,
 - 3) Telephone booth,
 - 4) Milk booth/Food stall,
 - 5) Florist,
 - 6) Information desk, and
 - 7) Snack and coffee stall.
- f) *Outdoor illumination, covering*
 - 1) Street light,
 - 2) Facade light, and
 - 3) Bollard light.
- g) *Tree protection units, covering*
 - 1) Tree guard,
 - 2) Tree grate, and
 - 3) Planter.
- h) *Garbage collection units, covering*
 - 1) Litter bin, and
 - 2) Spittoons.
- j) *Service utilities, relating to*
 - 1) Water supply network,
 - 2) Storm water network,
 - 3) Sewerage network,
 - 4) Electrical network,
 - 5) Telephone lines,
 - 6) Cable e-net, and
 - 7) Gas.
- k) *Display and Signage*
 Location of the street furniture has to coordinate with the traffic flow pattern of vehicles and pedestrians and external services. Some typical street furniture are given in Fig. 3.

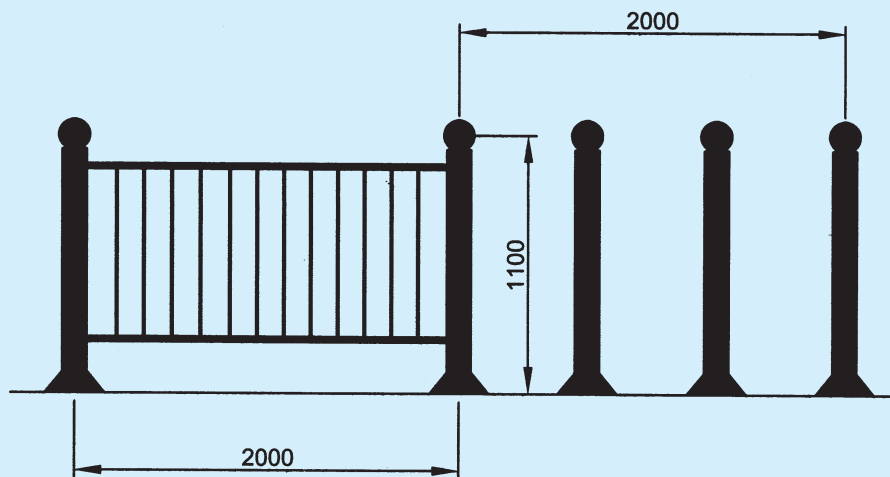

ELEVATION

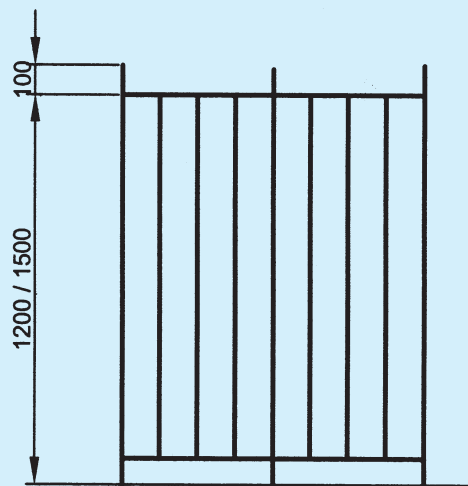

ELEVATION

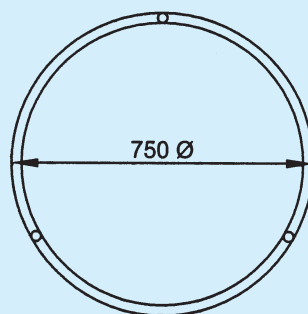

TREE GRILL

PLAN

All dimensions in millimetres.

3A BARRIER — FENCE AND BOLLARD COMBINATION

FIG. 3 TYPICAL STREET FURNITURE — *Continued*

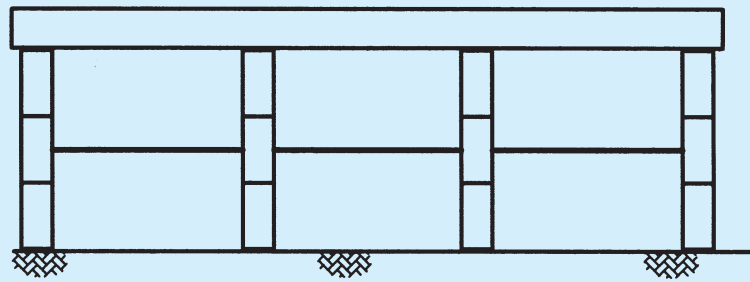

3B KIOSK

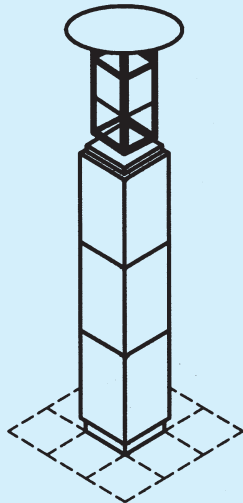

3C LIGHT POLE

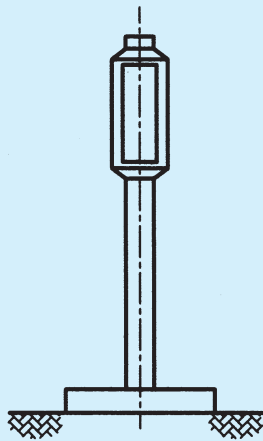

3D PARK LIGHT

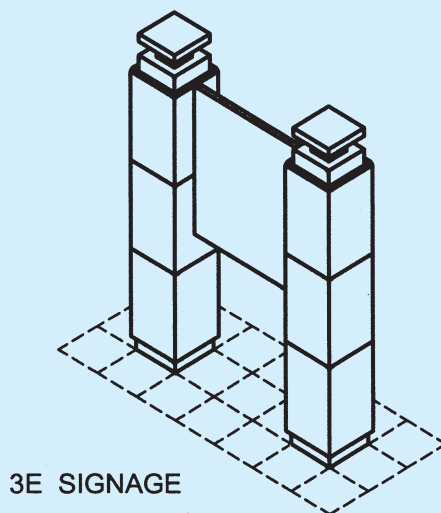
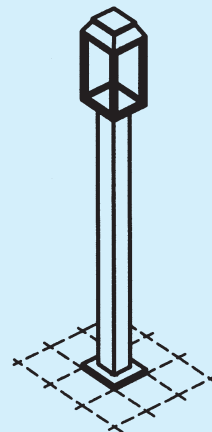

3E SIGNAGE

FIG. 3 TYPICAL STREET FURNITURE

NATIONAL BUILDING CODE OF INDIA

PART 10 LANDSCAPING, SIGNS AND OUTDOOR DISPLAY STRUCTURES

Section 2 Signs and Outdoor Display Structures

BUREAU OF INDIAN STANDARDS

CONTENTS

FOREWORD	...	3
1 SCOPE	...	5
2 TERMINOLOGY	...	5
3 PERMITS	...	6
4 MAINTENANCE AND INSPECTION	...	13
5 TYPES OF SIGNS	...	13
6 GENERAL REQUIREMENTS FOR ALL SIGNS	...	13
7 ELECTRIC SIGNS AND ILLUMINATED SIGNS	...	18
8 GROUND SIGNS	...	18
9 ROOF SIGNS	...	19
10 VERANDAH SIGNS	...	19
11 WALL SIGNS	...	20
12 PROJECTING SIGNS	...	20
13 MARQUEE SIGNS	...	20
14 SKY SIGNS	...	21
15 TEMPORARY ADVERTISING SIGNS, TRAVELLING CIRCUS SIGNS, FAIR SIGNS AND DECORATIONS DURING PUBLIC REJOICING	...	21
16 ADDITIONAL GUIDELINES FOR SIGNS IN URBAN AND RURAL AREAS	...	22
17 ENVIRONMENTAL GRAPHICS FOR CITY SCAPE	...	23
ANNEX A SPECIMEN FORM FOR APPLICATION FOR PERMIT TO ERECT, RE-ERECT OR ALTER ADVERTISING SIGN	...	23
LIST OF STANDARDS	...	24

FOREWORD

This Section covers the requirements of signs and outdoor display structures with regard to public safety, structural safety and fire safety. With the growing industrialization followed by urbanization of large number of cities and towns, the advertising signs and its appurtenant structures had increased. In the absence of any definite rules, the display of advertising signs had proceeded unrestrained resulting in a city or town littered indiscriminately with hoardings and advertising signs of all types. Consideration of the aspects of urban aesthetics and public safety, pointed to the necessity for building regulations for the control of advertising signs and structures.

This Section was, therefore, published in 1970 as Part 10 of the Code and was subsequently revised in 1983. In the first revision, comments and suggestions received during its use were incorporated. As a result of experience gained in implementation of 1983 version of this Section and feedback received, a need to revise this Section was felt. In the existing version of the Code, Part 10 is titled as Signs and Outdoor Display Structures. Now, this Part has been enlarged to also cover Landscaping. This Part is therefore, being brought out in two sections, namely Section 1 Landscape Planning and Design and Section 2 Signs and Outdoor Display Structure. This revision as Section 2 Signs and Outdoor Display Structure has, therefore, been prepared to take care of the need to update the same. The significant changes incorporated in this revision include:

- a) Few more terminologies related to signs have been added.
- b) Few explanatory figures have been added.
- c) Guidelines for signs in urban and rural areas have been introduced.
- d) Guidelines for environmental graphics for the city scape have been introduced.

The provisions of this Section are without prejudice to the regulations already in vogue in areas requiring special controls in harmony with their historical monuments/environment.

For signs coming on highways, relevant IRC rules shall apply. In this connection reference is made to 'IRC 46 : 1972 A policy on road advertisements'.

All standards, cross-referred to in the main text of this Section, are subject to revision. The parties to agreement based on this Section are encouraged to investigate the possibility of applying the most recent editions of the standards.

NATIONAL BUILDING CODE OF INDIA

PART 10 LANDSCAPING, SIGNS AND OUTDOOR DISPLAY STRUCTURES

Section 2 Signs and Outdoor Display Structures

1 SCOPE

This Section covers the requirements with regard to public safety, structural safety and fire safety of all signs and outdoor display structures.

2 TERMINOLOGY

2.0 For the purpose of this Section, the following definitions shall apply.

2.1 Signs

2.1.1 Abandoned Sign — A sign structure that has ceased to be used, and the owner intends no longer to use the same, for the display of sign copy, or as otherwise defined by state law.

2.1.2 Advertising Sign — Any surface or structure with characters, letters or illustrations applied thereto and displayed in any manner whatsoever out of doors for purposes of advertising or to give information regarding or to attract the public to any place, person, public performance, article or merchandise whatsoever, and which surface or structure is attached to, forms part of or is connected with any building, or is fixed to a tree or to the ground or to any pole, screen, fence or hoarding or displayed in space.

2.1.3 Banner — A flexible substrate on which copy or graphics may be displayed.

2.1.4 Banner Sign — A sign utilizing a banner as its display surface.

2.1.5 Canopy Sign — A sign affixed to the visible surface(s) of an attached or freestanding canopy.

2.1.6 Closed Sign — An advertising sign in which at least more than fifty percent of the area is solid or tightly enclosed or covered.

2.1.7 Combination Sign — A sign that is supported partly by a pole and partly by a building structure.

2.1.8 Direction Sign — Usually included with an arrow and used for indicating a change in route or confirmation to a correct direction.

2.1.9 Electric Sign — An advertising sign in which electric fittings, which are an integral part of the signs, are used.

2.1.10 Exterior Sign — Any sign placed outside a building.

2.1.11 Freestanding Sign — A sign principally

supported by a structure affixed to the ground, and not supported by a building, including signs supported by one or more columns, poles or braces placed in or upon the ground.

2.1.12 Ground Sign — An advertising sign detached from a building, and erected or painted on the ground or on any pole, screen, fence or hoarding and visible to the public.

2.1.13 Identification Sign — A sign that gives specific location information, identifies specific items, for example, Parking Lot B, Building No. 5, First Aid, etc.

2.1.14 Illuminated Sign — An advertising sign, permanent or otherwise, the functioning of which depends upon its being illuminated by direct or indirect light, and other than an electric sign.

2.1.15 Informational Sign — Used for overall information for general organization of a series of elements that is, campus plan, bus route, building layout, shopping mall plan, etc.

2.1.16 Mansard — An inclined decorative roof-like projection that is attached to an exterior building façade.

2.1.17 Marquee Sign — An advertising sign attached to or hung from a marquee canopy or other covered structure projecting from and supported by the building and extending beyond the building wall, building line.

2.1.18 Open Sign — An advertising sign in which at least fifty percent of the enclosed area is uncovered or open to the transmission of wind.

2.1.19 Parapet — A low wall or railing built along the edge of a roof or floor.

2.1.20 Portable Sign — Any sign not permanently attached to the ground or to a building or building surface.

2.1.21 Projecting Sign — An advertising sign affixed to any building element and projecting more than 300 mm therefrom.

2.1.22 Regulatory Sign — Sign that gives operational requirements, restrictions or gives warnings, usually used for traffic delineation or control, for example 'Stop', 'No Parking', 'One Way', etc.

2.1.23 Roof Sign — An advertising sign erected or placed on or above the parapet or any portion of a roof

of a building including signs painted on the roof of a building.

2.1.24 Sky Sign — An advertising sign displayed in space like:

- a) a gas filled balloon anchored to a point on the ground and afloat in the air with or without a streamer of cloth, etc; or
- b) sky-writing, that is, a sign or word traced in the atmosphere by smoke discharged from an aeroplane.

2.1.25 Sign — Any device visible from a public place that displays either commercial or non-commercial messages by means of graphic presentation of alphabetic or pictorial symbols or representations. Non-commercial flags or any flags displayed from flagpoles or staffs shall not be considered as signs.

2.1.26 Sign Area — The area of the smallest geometric figure, or the sum of the combination of regular geometric figures, which comprise the sign face. The area of any double-sided or 'V' shaped sign shall be the area of the largest single face only. The area of a sphere shall be computed as the area of a circle. The area of all other multiple-sided signs shall be computed as 50 percent of the sum of the area of all faces of the sign.

2.1.27 Sign Copy — Those letters, numerals, figures, symbols, logos and graphic elements comprising the content or message of a sign, exclusive of numerals identifying a street address only.

2.1.28 Sign Face — The surface upon, against or through which the sign copy is displayed or illustrated, not including structural supports, architectural features of a building or sign structure, non-structural or decorative trim, or any areas that are separated from the background surface upon which the sign copy is displayed by a distinct delineation, such as a reveal or border.

2.1.29 Sign Structure — Any structure supporting a sign.

2.1.30 Temporary Sign — An advertising sign, banner or other advertising device constructed of cloth, canvas, fabric or any other light material, with or without a structural frame, intended for a limited period of display; including decorative displays for holidays or public demonstrations.

2.1.31 VERANDAH Sign — An advertising sign attached to, posted on or hung from a VERANDAH.

2.1.32 Wall Sign — An advertising sign, other than a projecting sign, which is directly attached to or painted or pasted on the exterior surface of or structural element of any building.

2.1.33 Window Sign — A sign affixed to the surface of a window with its message intended to be visible to and readable from the public way or from adjacent property.

2.2 General

2.2.1 Approved — Approved by the Authority having jurisdiction.

2.2.2 Area of Special Control — Any area declared an area of special control by the Authority in respect of the display of advertising signs, where the requirements for such display are more restrictive than elsewhere in the area controlled by the Authority.

2.2.3 Authority Having Jurisdiction — The Authority which has been created by a statute and which for the purpose of administering the Code/Part, may authorize a committee or an official to act on its behalf; hereinafter called the 'Authority'.

2.2.4 Building Line — The line up to which the plinth of a building adjoining a street or an extension of a street or on a future street may lawfully extend. It includes the lines prescribed, if any, in any scheme.

2.2.5 Combustible Material — A material is combustible, if it burns or adds heat to a fire when tested for non-combustibility in accordance with good practice [10-2(1)].

2.2.6 Owner — Person or body having a legal interest in land and/or building thereon. This includes free holders, leaseholders or those holding a sub-lease which both bestows a legal right to occupation and gives rise to liabilities in respect of safety or building condition.

In case of lease or sublease holders, as far as ownership with respect to the structure is concerned, the structure of a flat or structure on a plot belongs to the allottee/lessee till the allotment/lease subsists.

2.2.7 Street Line — The line defining the side limits of a street.

3 PERMITS

3.1 Application

3.1.1 Conditions for Grant of Permit

No sign shall be erected, altered or maintained without first obtaining a permit for the same from the Authority and shall be subjected to the following conditions:

- a) The written permission shall not be granted or renewed at any one time, for a period exceeding three years from the date of grant of such permission or renewal.
- b) The written permission or the renewal granted by the Authority shall become void:

- 1) if any sign or the part thereof falls either through an accident or any other causes;
 - 2) if any addition is made except for the purpose of making it secure under the direction of the Authority;
 - 3) if any change is made in the sign or part thereof;
 - 4) if any addition or alteration is made to the building or structure upon or over which the sign is erected and if such addition or alteration involves disturbance of the sign or any part thereof; and
 - 5) if the building or structure upon or over which the sign is erected fixed or restrained becomes demolished or destroyed.
- c) Light and ventilation of buildings, if any situated near the signs and hoardings shall not be obstructed in any way;
 - d) Advertisements displayed shall not be of any objectionable or obscene nature given in **3.3**;
 - e) In the public interest the Authority shall have the right to suspend the licence even before the expiry period, upon which the licensee shall remove the signs;
 - f) The licensee shall be responsible for the observance of all the rules and regulations laid down by the Authority;
 - g) The signs should not mar the aesthetic beauty of the locality;
 - h) The signs other than pertaining to building shall not be permitted to come in front of buildings such as hospitals, educational institutions, public offices, museums, buildings devoted to religious worship and buildings of national importance;
 - j) Maintenance and inspection of advertising signs and their supports shall be as given in **4**.
 - k) No hoarding sign on the highways shall be put without the permission of the Authority maintaining/incharge of flyovers, highways/roads; and
 - m) In addition all signs shall conform to the general requirements given in **6**.
 - n) The signs shall not be nailed or tied to trees or any other woody vegetation.

3.1.2 Application for Licence or Permit and Required Drawings

Every person intending to erect, alter or display an advertising sign for which a permit or licence is

required, shall make application to the Authority on the prescribed form containing such particulars as the Authority may require. Such a form (*see Annex A*) shall be signed by the applicant and by the owner of the site upon which such sign is or is to be situated and shall include the following information:

- a) Full specifications showing the length, height and weight of the sign, the location where it is to be erected, the manufacturer's name and address and where applicable, the number of lights and electrical details of the same.
- b) Such form shall be accompanied by a location plan indicating the position of the sign on the site drawn to a scale of 1:500 and by full detail drawing drawn to a scale of 1:20 or an exact multiple thereof in ink or on prints including, if required by the Authority, an elevation showing the sign in relation to the façade.
- c) In the case of roof signs, projecting signs or ground signs in addition to the foregoing, the size of all members of supporting frameworks and anchorages, and, if required by the Authority, the necessary design calculations shall be furnished with the application.
- d) Any other particulars as may be desired by the Authority covered in **6**.
- e) In the case of sky signs, necessary information as desired by the Authority may be supplied.

3.1.3 The Authority may, on the receipt of an application for permit, either sanction or refuse such a permit or sanction with modifications as deemed necessary and shall communicate decision to the applicant. If within 30 days of receiving an application for a permit the Authority fails to intimate in writing to the applicant, the permit along with the plans shall be deemed as sanctioned.

3.1.4 When a sign has to be altered, information only on such plans and statements, as may be necessary, shall be included in the form. However, the changing of movable parts of an approved sign that is designed for such changes, shall not be deemed an alteration provided the conditions of the original approval and the requirements of this part are not violated.

3.1.5 Existing Advertising Signs

Advertising signs in existence at the date of promulgation of the Code and covered by a valid licence or permit issued by the Authority shall not require to be licensed under the Code until such licence or permit has expired, provided it is maintained in a good and safe condition.

3.1.6 For advertising signs application shall be submitted through a structural engineer along with

necessary drawings and structural calculations. The wind load taken in the design calculations shall be in accordance with Part 4 'Structural Design, Section 1 Loads, Forces and Effects'.

3.2 Exemptions

3.2.1 No permit shall be required for signs and outdoor display structures of the following types:

- a) If the signs are exhibited within the window of any building provided it does not affect light and ventilation of the building.
- b) If it relates to the trade or business carried on within the land or building upon which such advertisement is exhibited or to any sale, entertainment or meeting or lettering of such land or building or any effects therein; or to the trade or business carried on by the owner of any tramcar, omnibus or other vehicle upon which such advertisements is exhibited, *provided it is not more than 1.2 m².*
- c) In addition no permission shall be required for the signs covered in **3.2.2** to **3.2.5**. Such exemptions, however shall not construed to relieve the owner of the sign from the responsibility of erection and maintenance in compliance with the Code.

3.2.2 Wall Signs

The wall signs listed in **3.2.2.1** to **3.2.2.3** shall not require a permit.

3.2.2.1 Store signs

Non-illuminated signs erected over a show window or over the door of a store or business establishment which announce the name of the proprietor and the nature of the business conducted therein; the sign shall not be more than 1 m in height and the width of the business establishment.

3.2.2.2 Government building signs

Signs erected on a municipal, state or central government building which announce the name, nature of the occupancy and information.

3.2.2.3 Name plates

Any wall sign erected on a building or structure indicating the name of the occupant of building, which is not more than 0.5 m² in area.

3.2.3 Ground Signs

3.2.3.1 Transit directions

The erection or maintenance of a sign designating the location of a transit line, a rail track, station or other public carrier when not more than 0.5 m² in area.

3.2.3.2 Highway Signs

In general, advertisements of the following classes are permissible without permission though these should reasonably conform to the principles set out in **3.5.1**:

Class (1) Functional Advertisements:

- a) Official warning signs, traffic directions, sign posting and notices or advertisements posted or displayed by or under the directions of any public or court officer in the performance of his official or directed duties.

Example:

DIVERSION AHEAD

- b) Direction signs to places of public amenity, such as petrol filling stations, hospitals, first-aid posts, police stations and fire stations.

Example:

HOSPITAL

BUS STATION

- c) Signs relating solely to any city, town, village or historic place, shrine, place of tourist interest:

Example:

ELLORA
CAVES

FARIDABAD
TOWN

- d) Signs, notices, etc, erected by the Defence Department for information of members of the armed forces or the public.

Example:

ARTILLERY RANGE AHEAD

- e) Signs restricting trespass of property, limited to 0.2 m² in area or less.

Example:

PRIVATE
PROPERTY

TRESPASSERS
WILL BE
PROSECUTED

- f) Signs or notices, 0.2 m² in area or less, placed so as to show direction to a residence and planted sufficiently away from the carriageway.

Class (2) Advertisements Relating to the Premises on which these are Displayed:

- a) Advertisements for the purpose of identification, direction or warning with respect to the land or building on which they are displayed, provided not exceeding 0.2 m² in area in the case of any such advertisement.

Examples:



- b) Advertisements relating to any person, partnership or company separately carrying on a profession, business trade at the premises where any such advertisement is displayed; limited to one advertisement not exceeding 0.3 m² in area in respect of each such person, partnership or company.

Example:

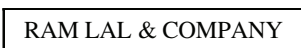

- c) Advertisements relating to any institution of a religious, educational, cultural, recreational, medical or similar character or any hotel, public house, dark bungalow, block of flats, club, boarding house or hostel situated on the land on which any such advertisement is displayed; limited to one advertisement not exceeding 1.2 m² in area in respect of each such person, partnership or company.

Examples:

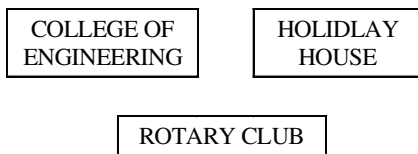

Class (3) Advertisements of Temporary Nature

- a) Advertisements relating to the sale or letting of the land on which they displayed; limited in respect of each such sale or letting to one advertisement not exceeding 2 m² in area.

Examples:

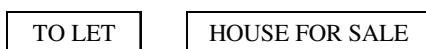

- b) Advertisements announcing sale of goods or livestock, and displayed on the land where such goods or livestock are situated or where such sale is held, limited to one advertisement not exceeding 1.2 m² in area.

Examples:



- c) Advertisements relating to the carrying out of building or similar work on the land on which they displayed exceeding 2 m² in area.

Example:



- d) Advertisements announcing any local event of a religious, educational, cultural, political, social or recreational character, not being an activity promoted or carried on for commercial purposes; limited to a display of advertisements occupying an area not exceeding 0.6 m² on any premises.

Examples:



3.2.4 Temporary Signs

3.2.4.1 Construction site signs

Construction signs, engineers' and architects' signs and other similar signs which may be authorized by the Authority in connection with construction operations (*see* Table 1).

3.2.4.2 Special displays signs

Special decorative displays used for holidays, public demonstrations or promotion of civic welfare or charitable purposes, on which there is no commercial advertising, provided that the Authority is not held responsible for any resulting damage (*see* 15.2.2).

3.2.5 The qualitative requirements of signs given in Table 1 shall not require any permit.

3.3 Unsafe and Unlawful Signs

3.3.1 Notice of Unsafe and Unlawful Signs

When any sign becomes insecure, or in danger of falling, or otherwise unsafe, or if any sign shall be unlawfully installed, erected or maintained in violation of any of the provisions of the Code, the owner thereof, or the person or firm maintaining the same, shall upon written notice of the Authority, forthwith in the case of immediate danger and in any case within not more than three days, make such sign conform to the provisions of this part or shall remove it. If within three days the order is not complied with, the Authority may remove such sign at the expense of the owner.

3.3.1.1 Notwithstanding the above, it shall be the responsibility of the owner to ensure the safety of the advertising signs, even without a reference from the Authority. The owner shall also ensure to remove the remnant structures of the abandoned sign.

3.3.2 The following signs may not be permitted under any circumstances:

Any sign which in the opinion of the Authority is an

Table 1 Advertising Signs for Which No Permit or Licence is Required
(Clause 3.2.5)

Class (with Sample)	Area of Each Separate Sign (or Aggregate)	Maximum Height Above Ground Floor Level to Top of Sign	Illumination Provided	Description of Sign		Remarks
				Number Permitted	Maximum Dimension of Letters, Symbols, etc	
(1)	(2)	(3)	(4)	(5)	(6)	(7)
1) Functional signs of certain authorities statutory undertakings, public transport undertakings, and fire brigades, etc	As may be reasonably required for the safe and efficient performance of the function	As stated in col 2	As stated in col 2	As stated in col 2	As stated in col 2	As stated in col 2
BUS STATION						
2) Miscellaneous signs relating to premises on which they are displayed	Not more than 4 m ²	Not more than 5 m (in area of special control 4 m)	Only to indicate that medical or similar services or supplies are available on premises where advertisement is displayed*	Any number	Not more than 750 mm (in area of special control 300 mm)	
a) Identification, direction, or warning						
X-RAY UNIT						
MIND THE STEP						
b) Person partnership or company carrying profession business, or trade; name or private person	Not more than 0.3 m ² each	Not more than 5 m (in area of special control 4 m)	Only to indicate that medical or similar services or supplies are available on premises where advertisement is displayed*	One at each entrance	Not more than 750 mm (in area of special control 300 mm)	
CHAWLA & CO. LTD.						
S. BOSE						
c) Relating to any institution of a religious, educational, cultural, or medical character; name of building or premises	Not more than 1.2 m ² each	Not more than 5 m (in area of special control 4 m)	Only to indicate that medical or similar services or supplies are available on premises where advertisement is displayed*	One on each frontage	Not more than 750 mm (in area of special control 300 mm)	
COLLEGE OF COMMERCE						
XYZ FLATS						
3) Temporary signs (cloth banners)	Not more than 2.4 m ² (ratio of width to depth 2:1) in aggregate area. No sign to project more than 1 m when displayed on a building (within the site)	Not more than 5 m (in area of special control 4 m)	None	Any number but aggregate area not to exceed that given in col 2	Not more than 750 mm (in area of special control 300 mm)	Shall not be displayed earlier than 28 days before the sale or other matter is due to start and shall be removed within 14 days after the conclusion of such sale or matter
a) Signs relating to the sale or letting off the land (within the site of the building) on which they are displayed						
HOUSE FOR SALE						

Table 1 — Concluded

Class (with Sample)	Area of Each Separate Sign (or Aggregate)	Maximum Height Above Ground Floor Level to Top of Sign	Illumination Provided	Description of Sign		Remarks
				Number Permitted	Maximum Dimension of Letters, Symbols, etc	
(1)	(2)	(3)	(4)	(5)	(6)	(7)
b) Signs relating to the carrying out of building or similar operations on the land where sign is displayed	Not more than 4 m ²	Not more than 5 m (in area of special control 4 m)	None	One for each road frontage for each contractor or sub-contractor	Not more than 750 mm (in area of special control 300 mm)	May be displayed only while such works are in progress
		THIS FACTORY IS BEING ERECTED BY XYZ CONSTRUCTION CO. Building and Engineering Contractor				
c) Signs announcing any local event in connection with an activity promoted for non-commercial purposes by various local organizations	Not more than 1.5 m ² (in aggregate area 4 m)	Not more than 5 m (in area of special control 4 m)	None	Any number but aggregate area not to exceed that given in col 2 on any premises	Not more than 750 mm (in area of special control 300 mm)	Shall not be displayed earlier than 28 days before the event is due to start and shall be removed within 14 days of its conclusion
		DIWALI MELA				
d) Signs and business premises for areas of special control, signs on business premises with reference to the business, the goods sold, or the services provided, etc. in these premises and the name and qualifications of the person carrying on such activity	Not to exceed one-twelfth of area of each face up to a height of 4 m	Not more than 4 m	Only to indicate that medical or similar services or supplies are available where advertisement is displayed*	Any number but aggregate area not to exceed that given in col 2	Not more than 300 mm	Area to be computed as if the advertisement were laid flat against the face of the building
		XYZQR BANK				

* or where connected with danger.

obscene, repulsive, revolting, or objectionable character or prejudicial to the municipality or savouring political propaganda or of a nature calculated to produce pernicious or injurious effect on public or any particular class of persons, or is displayed in such a place, in such a manner or by any such means as, in the opinion of the Authority, could be likely to affect injuriously the amenities of, or to disfigure any neighbourhood.

3.4 Area of Special Control

3.4.1 Whenever in the opinion of the Authority it is likely that any advertising device otherwise permitted in terms of the Code may affect injuriously or disfigure any particular area within the jurisdiction of the Authority it may proclaim such area as an area of special control. Parks and land for public use may also be included as areas of special control.

3.4.2 Subject to the provisions of **3.4.1** within such area, the erection and display of any advertising sign shall be prohibited or restricted in any manner deemed necessary by the Authority. The Authority shall publish its intention of proclaiming such an area in one or more newspapers circulating in the area of jurisdiction of the Authority. Any owner of property within such area who may feel aggrieved by such proclamation may appeal within one month from such publication against proclamation of such an area to the Authority whose decision shall be final.

3.4.3 The wording on any *VERANDAH* sign, permitted by the Authority, in any area of special control, shall be restricted to the name of the proprietor or firm occupying the premises, the name of the building or institution, the general business or trade carried on, such as 'JEWELLER', 'CAFÉ', 'DANCING', or information regarding the location of the building entrance, box office or regarding the theatre programme or similar information. No *VERANDAH* sign in any area of special control shall advertise any particular article of merchandise nor shall any such sign refer to price or reduction in price.

3.4.3.1 Normally no other advertising sign shall, except as for **3.4.3**, be within a distance of 30 m from the area of special control.

3.5 Prohibition of Advertising Signs on Certain Sites

Where the Authority is of the opinion that any site is unsuitable for display of advertising signs by virtue of the general characteristics of the locality in regard to historic, architectural, cultural or similar interest, or by virtue of its position, the display of such signs is likely to affect in any way the safety of any form of transport, erection of advertising signs on such a site shall be prohibited.

3.5.1 Highways and Roads

In general the following advertisements should not be permitted:

- a) At or within 100 m of any road junction, bridge or railway crossing or another crossing. In urban areas, this distance may be reduced to 50 m, provided there is no conflict with the requirements stated further on;

NOTE — The safe stopping distance for a vehicle travelling at a speed of 50 km/h is 60 m. This should be the 'uninfluenced distance' for a driver approaching a junction. Assuming that 3 seconds is the time during which the influence of an advertisement board persists, the distance travelled in this time will be about 40 m. The sign should, therefore, be more than 100 m away from the junction. Hence 100 m is suggested.

- b) In such manner and at such places as to obstruct or interfere with the visibility of approaching, merging or intersecting traffic;
- c) Within 10 m of the edge of a carriageway;

NOTE — A distance of 10 m may be taken as the normal minimum setback from the edge of the carriageway, the maximum area of the advertisement being 0.3 m² for every metre of setback.

- d) Within 50 m along the road, of any sign board erected for the regulation of traffic under the orders of a Public Authority, such as a Traffic Authority, a Public Transport Authority, or a Local Authority;
- e) In such a form as will obscure or hinder interpretation of any sign, signal or other device erected for traffic control by the Public Authorities. For instance, the advertisements should not imitate or resemble, in colour or shape, the standard legal traffic signs, or employ such words as 'STOP' in the same manner as used on traffic signs;
- f) On boards, placards, cloth banners or sheets (except traffic signs) hung across a road as they distract the attention of driver and are, therefore, hazardous;

NOTE — Any advertisement allowed on the sides of a foot over bridge or flyover across the carriage-ways shall be restricted in size and shape such that no part of the advertisement board projects beyond the top, bottom and sides of the parapet of foot over bridge or flyover.

- g) In such form as will obstruct the path of pedestrians and hinder their visibility at crossings;
- h) Within right-of-way of the road; and
- j) When these will affect local amenity.

3.5.2 Illuminated advertisements of the following description are objectionable from the angle or traffic safety and should not be allowed:

- a) Advertisements which contain, include or are

illuminated by any flashing, intermittent or moving light or lights except those giving public service information, such as time, temperature, weather or date;

- b) Illuminated advertisements of such intensity or brilliance as to cause glare or impair vision of the driver or pedestrians, or which otherwise interfere with any operations of driving; and
- c) Advertisements illuminated in such a way as to obscure or diminish effectiveness of any official sign, device or signal.

4 MAINTENANCE AND INSPECTION

4.1 Maintenance

All signs for which a permit is required, together with all their supports, braces, guys and anchors shall be kept in good repair, both structurally and aesthetically, and when not galvanized or constructed of approved corrosion-resistive non-combustible materials, shall be painted when necessary to prevent corrosion.

4.2 Housekeeping

It shall be the duty and responsibility of the owner of every sign to maintain the immediate premises occupied by the sign, in a clean, sanitary and healthy condition.

4.3 Inspection

Every sign for which a permit has been issued and every existing sign for which a permit is required shall be inspected by the Authority at least once in every calendar year.

5 TYPES OF SIGNS

In this part, the following types of signs are covered [see also a few explanatory figures of general sign types (Fig. 1A), comparison of roof and wall or fascia sign (Fig. 1B) and sign area computation methodology (Fig. 1C and 1D)].

- a) Electric and illuminated signs (*see 7*);
- b) Ground signs (*see 8*);
- c) Roof signs (*see 9*);
- d) VERANDAH signs (*see 10*);
- e) Wall signs (*see 11*);
- f) Projecting signs (*see 12*);
- g) Marquee signs (*see 13*);
- h) Sky signs (*see 14*); and
- j) Miscellaneous and temporary signs (*see 15*).

6 GENERAL REQUIREMENTS FOR ALL SIGNS

6.1 Loads

Every advertising sign shall be designed so as to

withstand safely the wind, dead, seismic and other loads as set out in Part 6 'Structural Design, Section 1 Loads, Forces and Effects'.

6.2 Illumination

No sign shall be illuminated by other than electrical means and electrical devices and wiring shall be installed in accordance with the requirements of Part 8 'Building Services, Section 2 Electrical and Allied Installations'. In no case, shall any open spark or flame be used for display purposes unless specifically approved by the Authority.

6.3 Design and Location of Advertising Signs

- a) Sign should not obstruct any pedestrian movement, fire escape, door or window, opening used as a means for egress or fire fighting purposes.
- b) No sign shall in any form or manner interfere with openings required for light and ventilation.
- c) When possible signs should be gathered together into unified systems. Sign clutter should be avoided in the landscape.
- d) Signs should be combined with lighting fixture to reduce unnecessary posts and for ease of illuminating the signs.
- e) Information signs should be placed at natural gathering spots and included in the design of sight furniture.
- f) Placement of sign should be avoided where they may conflict with pedestrian traffic.
- g) Sign should be placed to allow safe pedestrian clearance vertically and latterly.
- h) Braille strips may be placed along sign edges or raised letters may be used for readability for the blind and partially sighted.
- j) No sign shall be attached in anyway to a tree or shrub.

6.4 Use of Combustibles

6.4.1 Ornamental Features

Wood or plastic or other materials of combustible characteristics similar to wood may be used for mouldings, cappings, nailing blocks, letters and latticing where permitted and for other purely ornamental features of signs.

6.4.2 Sign Facings

Sign facings may be made of approved combustible materials provided the area of each face is not more than 10 m² and the wiring for electric lighting is entirely enclosed in metal conduit and installed with a clearance of not less than 5 cm from the facing material.

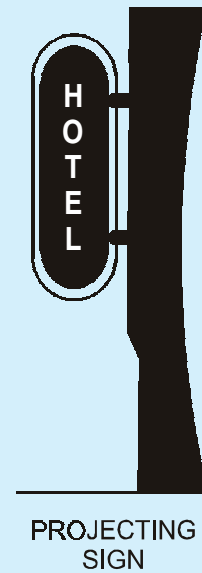
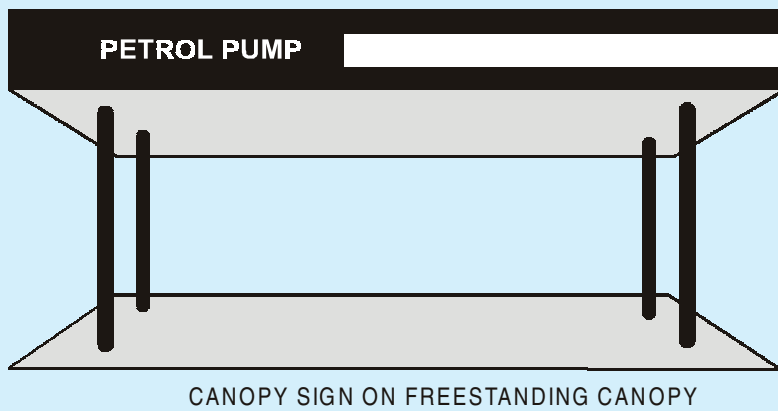
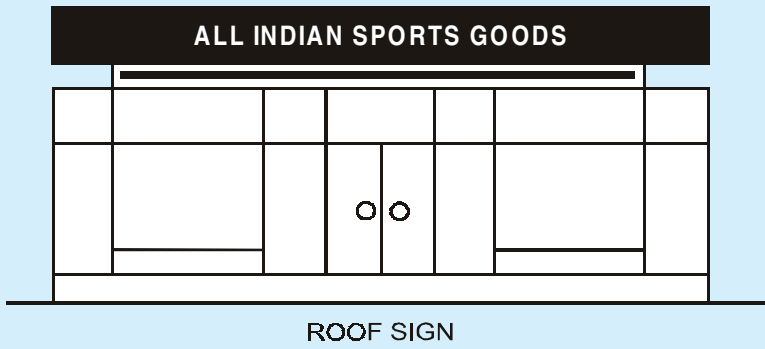
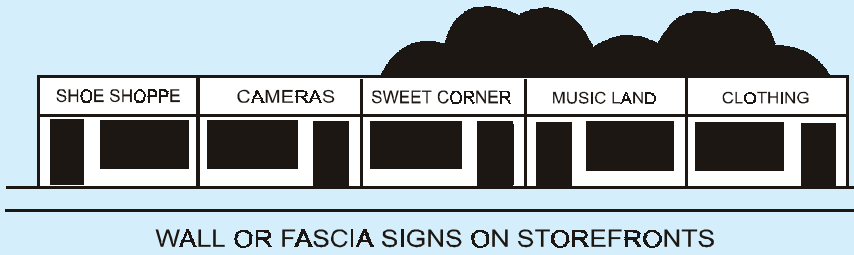
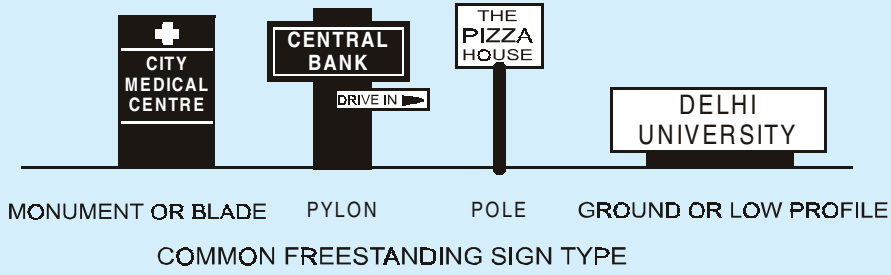

1A GENERAL SIGN TYPES

FIG. 1 TYPICAL EXAMPLES OF SIGN TYPE — *Continued*

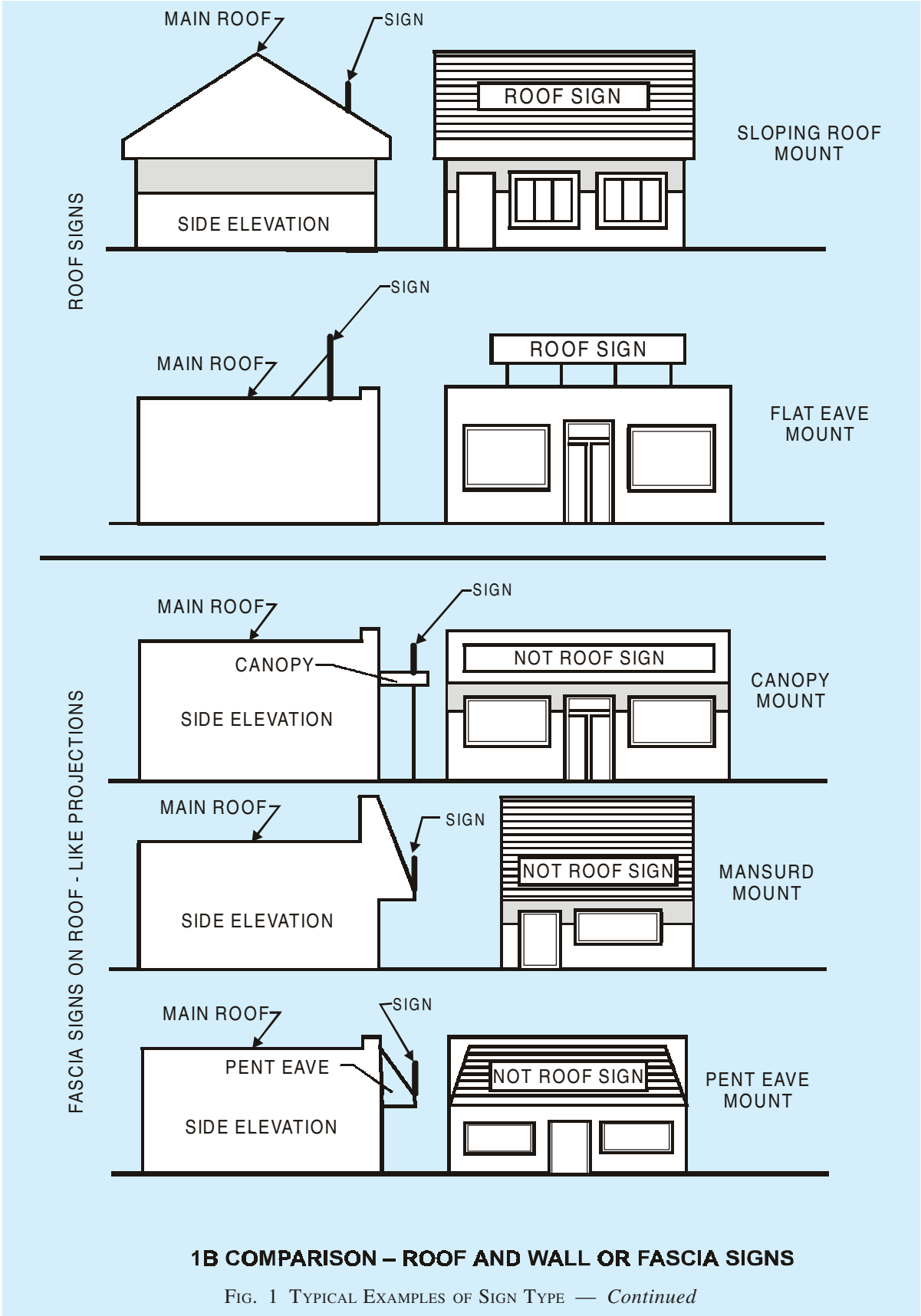

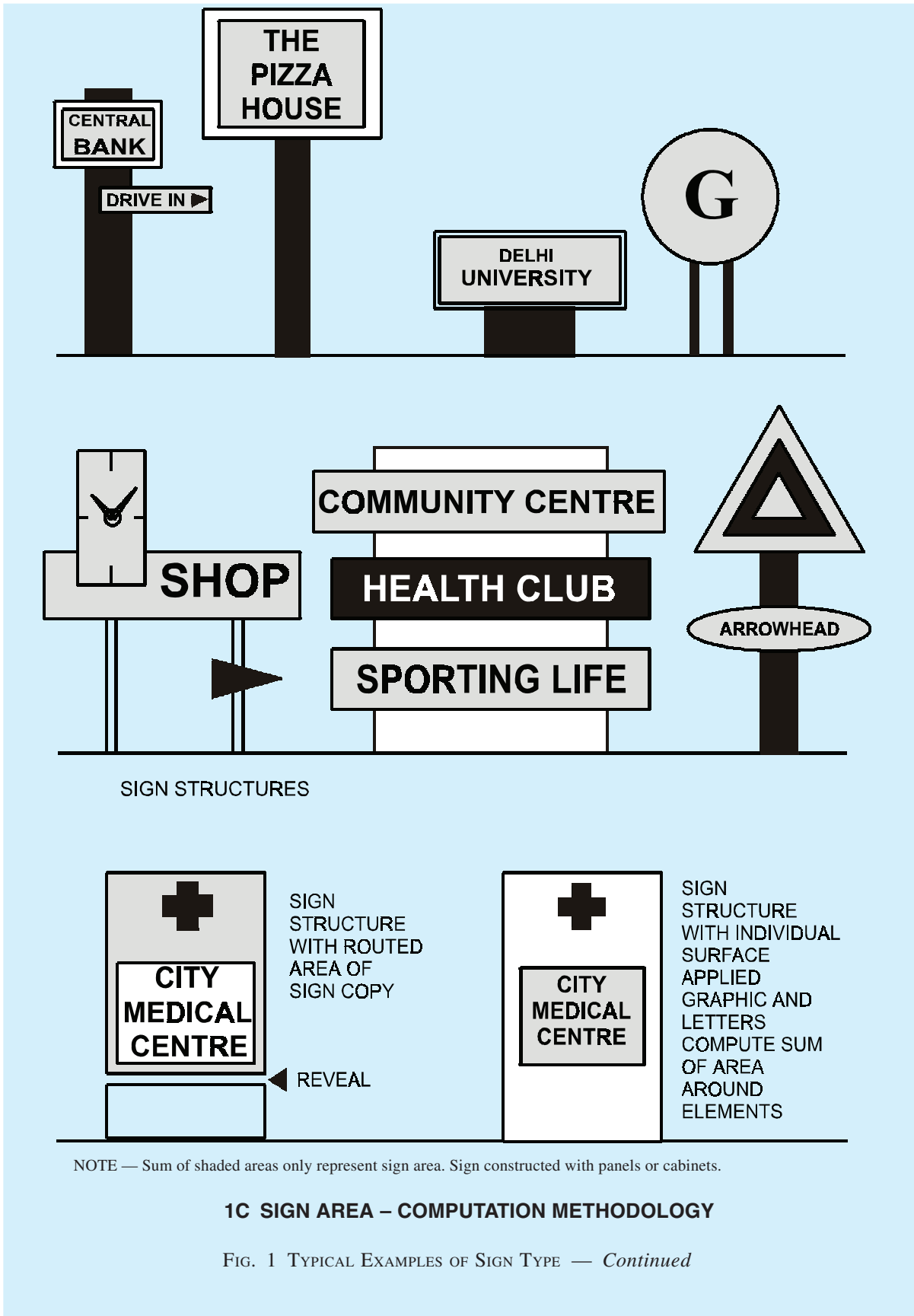

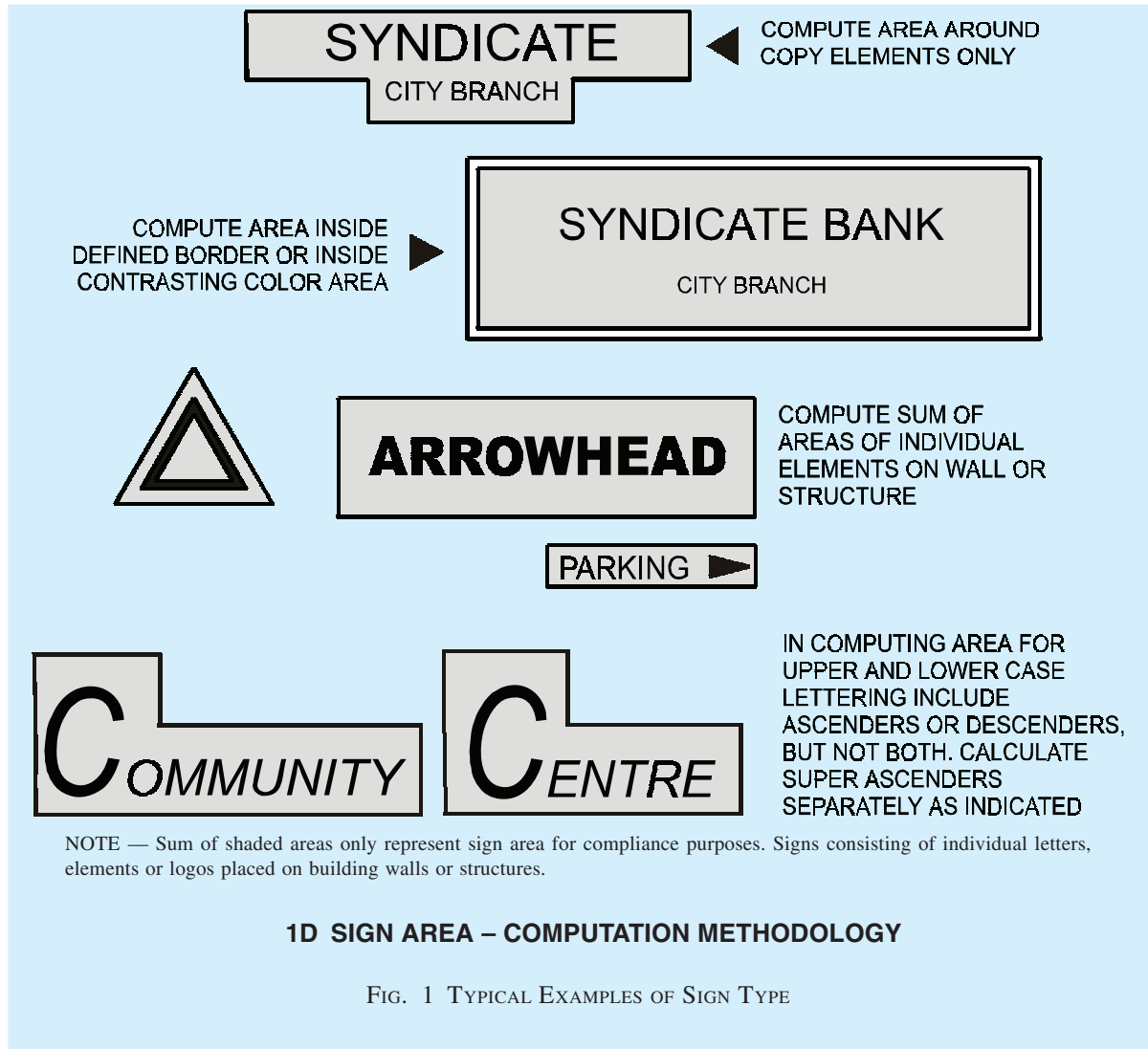

6.5 Damage or Defacement by Removal of Advertising Signs

Whenever any advertising sign is removed, whether in consequence of a notice or order under the Code or otherwise, any damage or defacement to the building or site on or from which such sign was displayed, shall be made good to the satisfaction of the Authority.

6.6 Alteration to Ground Level

Whenever any alteration is made to the ground level adjacent to any advertising sign, the owner of the site on which sign is erected, shall be responsible for the alteration of the height of such sign so as to conform to the requirements of this Section.

6.7 Traffic Control Interference

No advertising sign shall be erected or maintained which interferes with or is likely to interfere with any sign or signal for the control of traffic.

6.7.1 No advertising sign shall be placed particularly in bends and curves so as to obstruct the view of traffic at intersecting streets.

6.8 Draining of Signs

Adequate provision for drainage shall be made in every advertising sign, where the possibility of collection of moisture exists.

6.9 Glass in Signs

All glass used in advertising signs, other than glass tubing used in gas discharge or similar signs, shall be of safety glass conforming to accepted standards [10-2(2)] at least 3 mm thick. Glass panels in advertising signs shall not exceed 6 m² in area, each panel being securely fixed in the body of the sign independently of all other panels. Glass signs shall be properly protected from the possibility of damage by falling objects by the provisions of suitable protecting metal canopies, or by other approved means. Use of

glass may be discouraged or avoided wherever possible for signs placed overhead.

6.10 Interference to Fire Hydrants

Advertising signs shall be so placed as not to obstruct the use of the hydrants or other fire fighting appliances.

6.11 Serving Devices

Ladders, platforms, hooks, rings and all other devices for the use of servicing personnel shall have safety devices and suitable design loadings (reference may also be made to Part 7 'Constructional Practices and Safety').

6.12 Animated Devices

Signs which contain moving section or ornaments shall have fail-safe provisions to prevent the section or ornaments from releasing and falling or shifting its centre of gravity more than 450 mm. The fail-safe device shall be in addition to the mechanism and its housing which operate the movable section or ornament. The fail-safe device shall be capable of supporting the full dead weight of the section or ornament when moving mechanism releases.

7 ELECTRIC SIGNS AND ILLUMINATED SIGNS

7.1 Material for Electric Signs

Every electric sign shall be constructed of non-combustible material except where the sign is purely a flood-lit sign.

7.2 Installation of Electric Signs and Illuminated Signs

Every electric sign and illuminated sign shall be installed in accordance with Part 8 'Building Services, Section 2 Electrical and Allied Installations'.

7.3 No illuminated sign in red, amber or green colour shall be erected or maintained within a horizontal distance of 10 m of any illuminated traffic sign.

7.4 All advertising signs illuminated by light other than a white light at height of less than two storeys or 6 m above the footpath, whichever be the greater height, shall be suitably screened so as to satisfactorily prevent any interference with any sign or signal for the control of traffic.

7.5 Intense Illumination

No person shall erect any sign which is of such intense illumination as to disturb the residents in adjacent or nearby residential buildings. Notwithstanding any permission given for such erection, any such sign

which after erection is, in the opinion of the Authority, of such intense illumination as to disturb the occupants of adjacent or nearby buildings shall, on the order of the Authority, be suitably altered or removed by the owner of the site concerned within such reasonable period as the Authority may specify.

7.6 Hours of Operation

No electric sign, other than those necessary in the opinion of the Authority in the interest of public amenity, health and safety, shall be operated between midnight and sunrise.

7.7 Flashing, Occulting and Animated

No flashing, occulting or animated advertising signs, the periodicity of which exceeds 30 flashes to the minute, shall be erected so that the lowest point of such signs is less than 9 m above the ground level.

7.8 For illuminated signs in the vicinity of airports, the Directorate General of Civil Aviation should be consulted.

8 GROUND SIGNS

8.1 Material

Every ground sign exceeding 6 m in height together with frames, supports and braces shall be constructed of non-combustible material except as in **6.4**.

8.2 Dimensions

No ground sign shall be erected to a height exceeding 9 m above the ground. Lighting reflectors may extend beyond the top or face of the sign.

8.3 Supports and Anchorage

Every ground sign shall be firmly supported and anchored to the ground. Supports and anchors shall be of treated timber in accordance with good practice [10-2(3)], or metal treated for corrosion resistance or masonry or concrete.

8.4 Site Cleaning

The owner of any site on which a ground sign is erected shall be responsible for keeping such part of the site as is visible from the street, clean, sanitary, unoffensive and free of all obnoxious substances and unsightly conditions to the approval of the Authority.

8.5 Obstruction to Traffic

No ground sign shall be erected so as to obstruct free access to or egress from any building.

8.6 Set Back

No ground sign shall be set nearer to the street line than the established building line.

8.7 Bottom Clearance

The bottom line of all ground signs shall be at least 0.6 m above the ground, but the intervening space may be filled with open lattice work or platform decorative trim.

8.8 Ground painted signs shall conform to the requirements of 6 and 7 where applicable.

9 ROOF SIGNS

9.1 Material

Every roof sign together with its frames, supports and braces, shall be constructed of non-combustible material, except as in 6.4. Provision shall be made for electric grounding of all metallic parts; and where combustible materials are permitted in letters or other ornamental features, all wiring and tubing shall be kept free and insulated therefrom.

9.2 Dimensions

No roof sign shall exceed the following heights on buildings of heights:

<i>Height of Building</i>	<i>Height of Sign, Max</i>
a) Not exceeding four storeys or 18 m	2 m
b) Five to eight storeys or exceeding 18 m but not exceeding 36 m	3 m
c) Exceeding eight storeys or 36 m, provided that in calculating the height of such signs, signs placed one above the other, or on planes at different levels of the same building shall be deemed to be one sign, whether or not such signs belong to different owners	5 m

9.3 Location

- No roof sign shall be so placed on the roof of any building as to prevent free passage from one part of the roof to another.
- No roof sign shall be placed on or over the roof of any building unless the entire roof construction is of non-combustible material.

9.4 Projection

No roof sign shall project beyond the existing building line of the building of which it is erected or shall extend beyond the roof in any direction.

9.5 Supports and Anchorage

Every roof sign shall be thoroughly secured and

anchored to the building on or over which it is erected. All loads shall be safely distributed to the structural members of the building.

9.6 For roof signs near the airports the Directorate General of Civil Aviation should be consulted.

9.7 Painted roof signs shall conform to the requirements of 6 and 7, where applicable.

10 VERANDAH SIGNS

10.1 Material

Every verandah sign shall be constructed entirely of non-combustible material except as in 6.4.

10.2 Dimensions

No VERANDAH sign exceed 1 m in height. No VERANDAH sign hanging from a VERANDAH shall exceed 2.5 m in length and 50 mm in thickness, except that VERANDAH box signs measuring not more than 200 mm in thickness, measured between the principal faces of the sign and constructed entirely of metal wired glass may be erected.

10.3 Alignment

Every VERANDAH sign shall be set parallel to the building line, except that any such sign hanging from a VERANDAH shall be set at right angles to the building line.

10.4 Location

VERANDAH signs, other than hanging signs only, shall be placed in the following locations:

- Immediately above the eaves of the VERANDAH roof in such a manner as not to project beyond the rear of the roof gutter;
- Against but not above or below the VERANDAH parapet or balustrade provided such parapet or balustrade is solid and the sign does not project more than 20 cm from the outside face of such parapet or balustrade; or
- On the VERANDAH beams or parapets in the case of painted signs.

10.5 Height of Hanging VERANDAH Signs

Every VERANDAH sign hanging from a VERANDAH shall be fixed in such a manner that the lowest point of such sign is not less than 2.5 m above the pavement.

10.6 Projection

Except as provided for in 10.4, no VERANDAH sign shall extend outside the line of the VERANDAH to which it is attached.

11 WALL SIGNS

11.1 Material

Every wall sign exceeding 4 m² in area shall be constructed of non-combustible material except as in 6.4.

11.2 Dimensions

- a) The total area of any wall sign shall not exceed 20 m² for every 15 m of building frontage to the street to which such sign faces; except that in the case of a wall sign, consisting only of the name of a theatre or cinema, the total area of such sign shall not exceed 200 m².
- b) No wall sign which exceeds 30 m² in area shall be located on any wall not directly facing the road; provided that any such sign or signs shall not exceed 25 percent of the side wall area visible from the street.

11.3 Projection

No wall sign shall extend above the top of the wall or beyond the ends of the wall to which it is attached. At any place where pedestrians may pass along a wall, any wall sign attached thereto shall not project more than 7.5 cm therefrom within a height of 2.5 m measured from the level of such place.

11.4 Supports and Attachment

Every wall sign attached to walls shall be securely attached. Wooden blocks or anchorage with wood used in connection with screws, staples or nails shall not be considered proper anchorage, except in the case of wall signs attached to walls of wood.

12 PROJECTING SIGNS

12.1 Material

Every projecting sign and its support and framework shall be constructed entirely of non-combustible material.

12.2 Projection and Height

No projecting sign or any part of its supports or framework shall project more than 2 m beyond the building; however it shall not project beyond the plot line facing the street; when it projects into the street it shall be at clear height of 2.5 m from the road (*see* Part 3 'Development Control Rules and General Building Requirements'):

- a) The axes of all projecting signs shall be at right angles to the main face of the building. Where a V-construction is employed for the faces, the base of the sign against the building shall not exceed the amount of the overall projection.

- b) No projecting signs shall extend above the eaves of a roof or above the part of the building face to which it is attached.
- c) The maximum height of a projecting sign shall be related to the height of the building to which it is attached in the following manners:

<i>Sl No.</i>	<i>Height of Building</i>	<i>Height of Sign, Max</i>
i)	Not exceeding four storeys or 18 m	9 m
ii)	Five to eight storeys or not exceeding 36 m	12 m
iii)	Exceeding eight storeys or 36 m	15 m

12.3 Supports and Attachment

Every projecting sign shall be securely attached to a building so that movement in any direction is prevented by corrosion-resistant metal brackets, rods, anchors, supports, chains or wire ropes so designed and arranged that half the number of such fixing devices may safely support the sign under all circumstances.

12.3.1 Staples or nails shall not be used to secure any projecting sign to any building.

12.4 Additional Loads

Projecting sign structures which could be used to support an individual on a ladder or other servicing device whether or not specifically designed for the servicing device shall be capable of supporting the anticipated additional load but in no case less than 500 kg concentrated horizontal load and 1 500 kg vertical concentrated load applied at the point of assumed loading or point of most eccentric loading. The building component to which the projecting sign is attached shall also be designed to support the additional loads.

13 MARQUEE SIGNS

13.1 Materials

Marquee signs shall be constructed entirely of metal or other approved non-combustible materials.

13.2 Height

Such sign shall not exceed 2 m in height nor shall they project below the fascia of the marquee nor lower than 2.5 m above the footpath.

13.3 Length

Marquee signs may extend the full length but in no case shall they project beyond the ends of the marquee.

14 SKY SIGNS

14.1 In the case of the sky signs, the regulations laid down by the Authority concerned shall apply.

15 TEMPORARY ADVERTISING SIGNS, TRAVELLING CIRCUS SIGNS, FAIR SIGNS AND DECORATIONS DURING PUBLIC REJOICING

15.1 Types

None of the following advertising signs shall be erected or maintained, other than as temporary signs erected in accordance with **15.2**:

- a) Any advertising sign which is painted on or fixed on to or between the columns of a *VERANDAH*;
- b) Any advertising sign which projects above or below any fascia, bearer, beam or balustrade of a *VERANDAH* or balcony;
- c) Any advertising sign which is luminous or illuminated and which is fixed to any fascia bearer, beam or balustrade of any splayed or rounded corner of a *VERANDAH* or balcony;
- d) Any streamer sign erected across a road;
- e) Any sign not securely fixed so as to prevent the sign swinging from side to side;
- f) Any advertising sign made of cloth, paper mache, or similar or like material but excluding licensed paper signs on hoardings or fences;
- g) Any advertising sign on a plot used or intended to be used exclusively for residential purposes, other than a brass plate or board preferably not exceeding 600 mm x 450 mm in size, affixed to the fence or entrance door or gate of a dwelling, and in the case of a block of flats, affixed to the wall of the entrance hall or entrance door of any flat; and
- h) Any sign on trees, rocks, hillsides and similar natural features.

15.2 Requirements for Temporary Signs

15.2.1 All temporary advertising, travelling circus and fair signs and decorations during public rejoicing shall be subject to the approval of the Authority and shall be subjected to the approval of the Authority and shall be erected so as not to obstruct any opening and to minimize fire risk.

15.2.2 The advertisement contained on any such sign shall pertain only to the business, industry or other pursuit conducted on or within the premises on which such sign is erected or maintained. Temporary

advertising signs shall be removed as soon as torn or damaged and in any case within 14 days after erection unless extended.

15.2.3 The Authority shall be empowered to order the immediate removal of any temporary advertising sign or decoration, where, in its opinion such action is necessary in the interests of public amenity and safety.

15.2.4 Pole Signs

Pole signs shall be constructed entirely of non-combustible materials and shall conform to the requirements for ground or roof signs as the case may be (*see 8 and 9*). Such signs may extend beyond the street line if they comply with the provisions for projecting signs (*see 12*).

15.2.5 Banner and Cloth Signs

Temporary signs and banners attached to or suspended from a building, constructed of cloth or other combustible material shall be strongly constructed and shall be securely attached to their supports. They shall be removed as soon as torn or damaged, and in no case later than 14 days after erection; except, that permits for temporary signs suspended from or attached to a canopy or marquee shall be limited to a period of 10 days.

15.2.6 Maximum Size

Temporary signs shall not exceed 10 m² in area.

15.2.7 Projection

Temporary signs of cloth and similar combustible construction shall not extend more than 300 mm over or into a street or other public space except that such signs when constructed without a frame may be supported flat against the face of a canopy or marquee or may be suspended from the lower fascia thereof but shall not extend closer to the footpath than 2.5 m.

15.2.8 Special Permits

All temporary banners suspended from building or hung on poles, which extend across streets or other public spaces shall be subject to special approval of the Authority.

15.2.9 Bill boards set up by the Authority shall be used for temporary signs, symbols, bills for entertainment, etc, so that other walls of the city are not defaced.

15.2.9.1 Bills for entertainment and other functions shall not be affixed on to building walls other than the bill boards (*see 15.2.9*). The organization responsible for such bills and posters shall be held responsible for any such defacement and non-removal of signs.

16 ADDITIONAL GUIDELINES FOR SIGNS IN URBAN AND RURAL AREAS

16.1 Erecting maintaining and owning signs in rural areas shall be encouraged so as to boost the information and economic status of the rural population.

16.2 The tolerance criteria for the permission granted towards putting up any signs for any urban area shall be as given in **16.2.1** to **16.2.4**.

16.2.1 Small Towns

The traffic hazards in small towns are few and the defacement due to excessive advertising signs has not occurred. Therefore, orderly development of signs may enliven the town environment and boost the economy. The tolerance here may be high. The following guidelines may be followed for signage:

- a) *Advertising Sign* — Electric sign, ground sign, building sign, illuminated sign, sky sign and temporary sign are permissible.
- b) *Directional Sign* — Electric sign, ground sign, building sign, illuminated sign and temporary sign are permissible while sky sign is not permissible.
- c) *Informational Sign* — Electric sign, ground sign, building sign, illuminated sign and temporary sign are permissible while sky sign is not permissible.
- d) *Identification Sign* — Electric sign, ground sign, building sign, illuminated sign and temporary sign are permissible while sky sign is not permissible.
- e) *Regulatory Sign* — Electric sign, ground sign, illuminated sign and temporary sign are permissible while building sign and sky sign are not permissible.

16.2.2 Medium Towns

The traffic hazards in medium towns are few and the defacement due to excessive advertising signs has not occurred. Proper design, erection and maintenance of the signs shall be encouraged. The following guidelines may be followed for signage:

- a) *Advertising Sign* — Electric sign, ground sign, building sign, illuminated sign, sky sign and temporary sign are permissible.
- b) *Directional Sign* — Electric sign, ground sign, illuminated sign are permissible while building sign, sky sign and temporary sign are not permissible.
- c) *Informational Sign* — Electric sign, ground sign, illuminated sign, and temporary sign are permissible while building sign and sky sign are not permissible.

- d) *Identification Sign* — Electric sign, ground sign, building sign, illuminated sign and temporary sign are permissible while sky sign is not permissible.
- e) *Regulatory Sign* — Electric sign, ground sign, illuminated sign and temporary sign are permissible while building sign and sky sign are not permissible.

16.2.3 Large Cities

The traffic is high and hazards of accidents are many in large cities. Defacement of buildings, roads and the urban spaces due to advertisements has to be checked. Therefore, the permissivity and tolerance for erecting signs is very low. The following guidelines may be followed for signage:

- a) *Advertising Sign* — Electric sign, ground sign, illuminated sign and sky sign are permissible while building sign and temporary sign are not permissible.
- b) *Directional Sign* — Ground sign, illuminated sign are permissible while electric sign, building sign, sky sign and temporary sign are not permissible.
- c) *Informational Sign* — Ground sign, illuminated sign, building sign and temporary sign are permissible while electric sign and sky sign are not permissible.
- d) *Identification Sign* — Electric sign, ground sign, building sign, illuminated sign and temporary sign are permissible while sky sign is not permissible.
- e) *Regulatory Sign* — Ground sign, illuminated sign and temporary sign are permissible while electric sign, building sign and sky sign are not permissible.

16.2.4 Mega and Metro Cities

The traffic hazards in mega and metro cities are many and the defacement due to excessive advertising signs has marred the urban environment. The density of population is very high and the danger of greater loss of life due to disasters is self evident. Therefore, the permissivity for erecting signs is very low and no tolerance exists for law breakers. The following guidelines may be followed for signage:

- a) *Advertising Sign* — Electric sign, ground sign, illuminated sign and sky sign are permissible while building sign and temporary sign are not permissible.
- b) *Directional Sign* — Ground sign, illuminated sign are permissible while electric sign, building sign, sky sign and temporary sign are not permissible.

- c) *Informational Sign* — Ground sign, illuminated sign and temporary sign are permissible while electric sign, building sign and sky sign are not permissible.
- d) *Identification Sign* — Electric sign, ground sign, building sign, illuminated sign and temporary sign are permissible while sky sign is not permissible.
- e) *Regulatory Sign* — Ground sign, illuminated sign and temporary sign are permissible while electric sign, building sign and sky sign are not permissible.

projects and landscape projects on a large scale, the following criteria should be followed for signs and outdoor display structures:

- a) The aesthetic and harmonious development of the visual environment.
- b) Signage for the handicapped at all grade changes, entry points to buildings and public conveniences and facilities. Braille strips used should be displayed not above 1.5 m height for the benefit of the visually impaired at all important nodes, entrances and routes. Ramps for the people on wheelchair should be highlighted with the appropriate international sign of the wheelchair. These need to be lighted adequately even for night time.
- c) Environmental graphics should be creatively designed to cater to the basic function of information, identity and way finding, with the objective of improvement of urban scape.
- d) Safety aspects.
- e) Protection of trees and other vegetation from harm due to signs.

17 ENVIRONMENTAL GRAPHICS FOR CITY SCAPE

17.1 The urban environment may be susceptible to confusion and chaos due to improper graphics, hoardings and advertisements. Therefore, the signage should be installed following requisite guidelines laid down keeping the functional, safety and aesthetic aspects in view.

The scale of the project should also be considered for implementing signage design. In urban design/planning

ANNEX A

(Clause 3.1.2)

SPECIMEN FORM FOR APPLICATION FOR PERMIT TO ERECT, RE-ERECT OR ALTER ADVERTISING SIGN

1. Type of sign
2. *Location:
 - a) Building/premises
 - b) Location of building/premises with respect to neighbouring streets
3. *Dimensions and details of the sign
4. Materials used for different parts
5. *Electrical and lighting details
6. *Structural details showing also supporting framework and anchorages
7. Mode of operation
 - * Plans as desired in 3.1.2(b) are enclosed.

Name and address of the applicant

Name and address of the owner of the building/premises

Signature
 Date

Signature
 Date

LIST OF STANDARDS

The following list records those standards which are acceptable as 'good practice' and 'accepted standards' in the fulfillment of the requirements of this Code. The latest version of a standard shall be adopted at the time of enforcement of the Code. The standards listed may be used by the Authority as a guide in conformance with the requirements of the referred clauses in the Code.

	<i>IS No.</i>	<i>Title</i>
(1)	3808 : 1979	Method of test for non-combustibility of building materials (<i>first revision</i>)
(2)	2553	Specification for safety glass:
	(Part 1) : 1990	General purpose (<i>third revision</i>)
	(Part 2) : 1992	For road transport
(3)	401 : 2001	Code of practice for preservation of timber (<i>fourth revision</i>)