

Daylighting and window design

Lighting Guide LG10: 1999

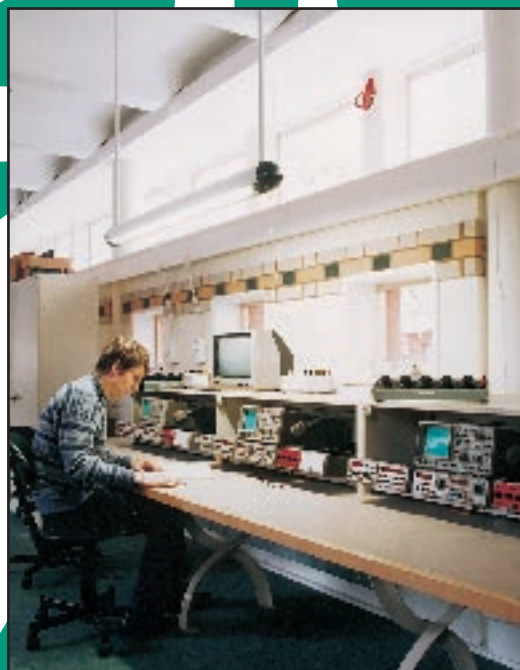

Daylighting and window design

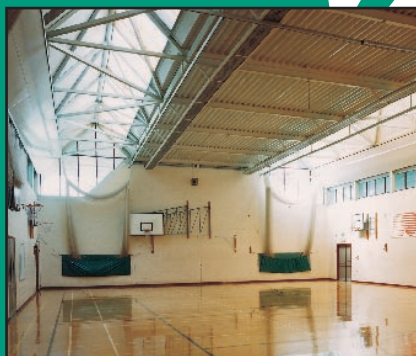

The Chartered Institution of Building Services Engineers
Delta House, 222 Balham High Road, London SW12 9BS

The rights of publication or translation are reserved.

No part of this publication may be reproduced, stored in a retrieval system or transmitted in any form or by any means without the prior permission of the Institution.

© October, 1999 The Chartered Institution of Building Services Engineers London

Registered charity number 278104

ISBN 0 900953 98 5

This document is based on the best knowledge available at the time of publication. However no responsibility of any kind for any injury, death, loss, damage or delay however caused resulting from the use of these recommendations can be accepted by the Chartered Institution of Building Services Engineers, the authors or others involved in its publication. In adopting these recommendations for use each adopter by doing so agrees to accept full responsibility for any personal injury, death, loss, damage or delay arising out of or in connection with their use by or on behalf of such adopter irrespective of the cause or reason therefore and agrees to defend, indemnify and hold harmless the Chartered Institution of Building Services Engineers, the authors and others involved in their publication from any and all liability arising out of or in connection with such use as aforesaid and irrespective of any negligence on the part of those indemnified.

Typeset by Jackie Wilson

Printed in Great Britain by The Friary Press, Dorchester

CIBSE gratefully acknowledges the illustrations from the following sources in this Lighting Guide:
ABK, James Bell, BRECSU, Building Research Establishment Ltd, Kit Cuttle, Derek Phillips and Soane Museum.

Foreword

This Lighting Guide replaces the CIBSE Applications Manual *Window design* which was published in 1987. The aim has been to build on the strengths of that manual and to update the design guidance and the way in which it is presented.

Daylighting and window design is essentially a daylight design guide and a major part of the content deals with this topic. When daylighting decisions are made, however, they will have implications for other, interrelated aspects of window performance such as solar heat gain, winter heat loss, provision of view, acoustic performance, privacy, security and protection from fire. The Lighting Guide signals the need for designers, whether architects or engineers, to consider these interrelated factors and to determine priorities for their relative importance. There is detailed design guidance on the main daylighting issues and sufficient information on the related issues to establish design priorities. There are also ample references throughout the text to CIBSE publications and other important sources of information.

Daylighting and window design has been written primarily for use when new design work is to be undertaken. However, much of the guidance will be applicable to refurbishment projects, although there may be constraints on the choices available for maximising daylight. The guidance in this publication is most applicable to projects in temperate climates where overcast sky conditions predominate.

Task Group

G K Jackson (Chairman)
P J Littlefair (Secretary)
M G Buckley
J Doggart
L J Heap
D L Loe
J A Lynes
D R H Phillips

P B Tregenza
R G Venning
M P Wilson
R E Yarham (CIBSE)

Contributors

P G T Owens
R R Walker

CIBSE coordinating editor

R E Yarham

Contract editor

J Wilson

Acknowledgements

Production of this Lighting Guide was supported by a project jointly funded by the research fund of the Chartered Institution of Building Services Engineers and by the Department of Environment, Transport and the Regions' Partners in Technology (now Partners in Innovation) programme. The Building Research Establishment was the subcontractor for this work. Thanks are also due to all those who commented on the document at various stages during its production. Some text and figures have been taken from the Hyperlight program produced by the Hyperlight Partnership.



This document is published with the Department's consent, but the views expressed therein are those of CIBSE and are not necessarily accepted or endorsed by the Department.

Note from the publisher

This publication is primarily intended to provide guidance to those responsible for the design, installation, commissioning, operation and maintenance of building services. It is not intended to be exhaustive or definitive and it will be necessary for users of the guidance given to exercise their own professional judgement when deciding whether to abide by or depart from it. For this reason also, departure from the guidance contained in this publication should not necessarily be regarded as a departure from best practice.

Contents

1	Role of windows in building design	1
1.1	Setting priorities	1
1.1.1	Daylight	1
1.1.2	Sunlight	2
1.1.3	View	3
1.1.4	Natural ventilation	4
1.1.5	Other constraints	5
1.2	Windows in the design process	6
1.2.1	Checklists for design	6
1.2.2	Building form	8
1.2.3	Window size and position	11
1.2.4	Window components: glazing and shading	13
1.2.5	Lighting and controls	14
1.2.6	Conclusion	15
2	Design	15
2.1	Siting and massing: building form and layout	15
2.1.1	Site characteristics	15
2.1.2	Building depth and overall size	16
2.1.3	Building orientation	21
2.1.4	Building positioning	24
2.1.5	Internal layout of building	28
2.2	Window and rooflight size, shape and position	29
2.2.1	Daylight requirements	29
2.2.2	Window size	30
2.2.3	Rooflights	35
2.2.4	Atria	37
2.2.5	Window shape and position	38
2.2.6	Ventilation	41
2.2.7	Provision for installation and maintenance	43
2.3	Window components	44
2.3.1	Choice of glazing type	44
2.3.2	Light and heat transmittance of glazing	47
2.3.3	Case study: reflected solar glare	48
2.3.4	Choice of shading devices	49
2.3.5	Interiors with display screen equipment	51
2.3.6	Daylight redirecting systems	53
2.3.7	Exhibition displays and ultraviolet filtering	55
2.3.8	Glazing for security	57
2.3.9	Frames and supporting structures	57
2.3.10	Window furniture and fittings	58
2.3.11	Noise insulation	59

2.4	Integration of daylight and electric light	61
2.4.1	Overall control strategy	61
2.4.2	Switching or dimming control	63
2.4.3	Light sources	63
2.4.4	Control hardware	64
2.4.5	Installation	68
3	Daylight calculations	68
3.1	Introduction	68
3.1.1	CIE skies	68
3.2	Manual calculations	69
3.2.1	Sky component	69
3.2.2	Externally reflected component	70
3.2.3	Internally reflected component	70
3.2.4	Correction factors	71
3.3	Computer methods	72
3.4	Scale model studies	73
3.4.1	Artificial skies	73
3.4.2	Guidelines	74
3.4.3	Sunlight studies	75
	References	78
	Bibliography	79
	Appendix: Supplementary data	82
	Glossary	86
	List of symbols	89
	Index	90

Daylighting and window design

1 Role of windows in building design

1.1 Setting priorities Windows have many roles to play including supplying daylight, providing views of the outside world, acting as a ventilator for air quality, providing mass cooling ventilation, and acting as a climate moderator, insulator, noise barrier and glare protector. They also have an important impact on the energy efficiency of a building. The designer will not always be able to reconcile the conflicting demands of these roles: prioritisation is needed, so that the most important issues are addressed.

1.1.1 Daylight Daylight (see Glossary for definition of terms used) was for centuries a crucial part of design. The alternative, candles, were expensive and most indoor work ceased after dark, with consequent loss of productivity. Partly as a result, building plans were often narrow and window sizes large. Electric lighting appeared to remove these constraints, allowing windows to be driven more by aesthetics than physical need and plan depths to be increased to reduce overall building costs.

New evidence shows that this was a simplistic view of daylight's contribution to user comfort and satisfaction. People like daylight: in a survey, 80% of the staff said that they wanted to sit by an openable window. In the Netherlands and Germany, health regulations prohibit buildings where staff sit farther than 6 metres from a window. The Building Research Establishment Environmental Assessment Method (see Bibliography) cites good daylight as contributing to healthy building design, which in turn has implications for absenteeism and productivity.

The primary purpose of a window, therefore, is to provide light to enable a building to function. This may demand high levels of light, as in a work space, but the level or intensity of light is less important than its quality. For light not only allows a building to function but also has an important, secondary role of creating a pleasant visual environment which leads to a feeling of well-being, which in itself will stimulate individual performance.

Throughout history, daylight has been a crucial factor in the design of buildings. It is difficult to find a perfect definition of a well daylit room as the subject is many faceted, but a quotation from Louis Kahn, one of the 20th century's foremost architects, helps to indicate its importance: 'I can't define a space really as a space, unless I have natural light ... natural light gives mood to space by nuances of light in the time of day and the season of the year as it enters and modifies the space' (see Figure 1.1).

Figure 1.1 Kimbell Art Gallery in Fort Worth, Texas, designed by Louis Kahn. Daylight enters through skylights with reflectors, while incandescent lighting illuminates the walls



Figure 1.2 Daylight brought into the centre of the John Lewis store, Kingston, to provide natural colour



Daylight is even more critical in some types of buildings — for example, design studios where the ability to judge colour accurately is important. Daylight, even though very variable, is the colour reference as all other forms of light change the perceived colour to a greater or lesser degree. Only daylight is thought to give true colours, even though the skylight (the diffuse component of daylight, see Glossary) varies from morning to evening and is further enhanced by sunlight. Special lamps, rather than daylight, are normally used for colour matching tasks.

In the late 19th century, large retail stores encouraged daylight entry for a variety of reasons, not least of which would have been the advantage of accurate colour, a practice which fell out of favour in the 20th century. With the present interest in daylighting, some large stores are being designed to introduce daylight (see Figure 1.2), a practice which is likely to develop further in a low energy ethos. This will be helpful to customers in matching colours of clothing, wallpaper etc, and may make goods look more attractive.

1.1.2 Sunlight

A key decision early in the design stage is the degree to which sunlight should be allowed to enter the building. This will depend on the type of activity within the building and the climate of its location.

It is important to recognise the benefits of sunlight. Sunlight increases the overall level of light and helps to provide a constant variation in the intensity, pattern and colour of light (see Figure 1.3). There is little doubt that entering a sunlit space is a pleasing experience and the interior of the great cathedrals, where the rays of the sun create shafts of light, is



Figure 1.3 Sunlight entering the Director's Room, Glasgow Museum of Art. The windows in this sidelit room have low sills and high heads to give good daylight distribution, while the splayed reveals reduce the contrast between the exterior and the window wall

unforgettable. In the home, sunlight should be encouraged to enter for some part of the day and there are few buildings where this is not the case.

Where access to direct sunlight is not possible, the impression of sunlight may be derived from an exterior view: sunlight on buildings at a distance, sunlit trees or a sunlit landscape. Humans have a strong desire to be able to perceive sunlight when it is known to be available, and occupants of a building are disappointed when this is denied.

With sunlight, however, come other consequences. Sunlight is an energy source, heating buildings. This is a bonus where the energy is needed in poorly insulated buildings, where internal heat gains are low and in winter. Where buildings are well insulated, internal gains are high, and in spring, summer and autumn, the heat gain can be a nuisance unless carefully controlled. Glare from sunlight also needs to be controlled (see section 2.3.4).

The above applies to the climate and building conditions in Britain, where the relatively low temperatures mean that sunlight is usually welcome. This is not true for all climates: for example, south of Paris levels of sunlight have to be monitored and controlled, and even daylight levels can be too high. Conversely, in Nordic countries daylight design is even more important than in the UK, because they experience longer periods without skylight or sunlight.

Latitude also affects how easily sunlight can be controlled. In the Mediterranean regions, sun paths are higher in the sky, making sunlight easier to control. In Nordic countries, sun paths are lower and sunlight is more difficult to control.

In almost all daylit buildings the control of incoming sunlight needs to be considered at the strategic planning stage. The only exceptions are buildings such as greenhouses where sunlight is always welcome.

1.1.3 View

The view through a window, or how we perceive the world outside, is a dynamic experience associated with changes in skylight, sunlight and season (see Figure 1.4). At its lowest level, a view satisfies the physiological need of the eye for a change of focus, and provides an awareness of the environment beyond the building.

The quality of the view is clearly of importance. Some views are of exceptional beauty and provide pleasure in themselves. However, any experience of the world beyond the window which extends our perception of space is good, no matter how banal. Research in Pennsylvania⁽¹⁾ suggested that patients in hospital recover quicker where there is access to an attractive view of trees and planting.



Figure 1.4 The view through windows at the Burrell Museum

Figure 1.5 House designed by Maxwell Fry in Chipperfield, Hertfordshire. Such architects generated a new experience of the concept of daylight and view



The development of manufacturing techniques, allowing much larger panes of glass, has produced a revolution in daylighting techniques where the wall can virtually disappear, the window occupying the whole façade and wrapping around the corners. Houses by architects such as Maxwell Fry (see Figure 1.5), Connell Ward and Lucas, and others generated a new experience of the concept of daylight and view.

View will depend on the location, size, shape and detailing of the window. However stimulating the exterior may be, windows which are too small, break up the view or are at a height that inhibits view from normal positions are less desirable (see section 2.2.5). There are some architectural projects where external view may be considered inappropriate — as for example in a church, shop, lecture room, cinema or theatre where the aim is to encourage occupants to concentrate solely on the task in hand. Nevertheless, there is a general presumption that a view through a window is good, and a daylight strategy that denies a view in any building needs to be questioned. In buildings comprising very large spaces, internal views to other daylighted areas may suffice.

The view out, however, has to be balanced by privacy, or the view in. Attitudes to privacy differ: in the UK the tendency is to stop people outside looking into domestic buildings; in the Netherlands they welcome it. There are many buildings such as stores where the view in is encouraged, but there are others where a sense of privacy associated with security denies a view.

The question of privacy can be addressed by using curtains and blinds which have the benefit of avoiding the ‘black hole’ appearance of the window at night. They also provide a means of reflecting electric light back into the room rather than losing it to the outside, but this will require a moderately high reflectance of the inside surface.

1.1.4 Natural ventilation

Window design can also be part of the ventilation strategy of the building and this needs to be considered at the planning stage. The simplest option is to provide fresh air, locally and manually controlled. In a naturally ventilated building, openable windows allow excess heat to be removed to prevent overheating on warm days and provide background ventilation for health and comfort on other days. Note that separate provisions can be made for background ventilation, such as trickle ventilators or other openings (or mechanical means). The design of window openings critically affects how easy the window is to use, the adequacy of ventilation and air movement for comfort, and the ability to avoid unwanted draughts (see also section 2.2.6).

Advanced natural ventilation can be used where night ventilation is required as part of a strategy to use the thermal mass of the building to cool the fabric of the building to lower daytime temperatures and reduce overheating. Window openings can be controlled locally by users or centrally using a building energy management system (BEMS). If using a BEMS, the algorithm for operating the windows should be simple to

understand and to commission, otherwise the system is likely to fail. One ventilation strategy is to use a mixed mode system which operates using natural or mechanical ventilation during winter, spring and autumn, and mechanical cooling only during the summer months. Experience to date shows that these systems are complex to commission and operate, and need a skilled management committed to their success. It is common in some countries to interlock window opening with the mechanical ventilation system, so that the system is disabled locally if a user opens a window. A further strategy relies on a sealed windows system and air conditioning to provide user comfort.

The choice of system will depend crucially on both the external environment and the internal heat loads (see Figure 1.6). If the local environment is noisy or the air polluted, windows are unlikely to be opened. Security must also be addressed, with the design tested both against rain and intruders. And if internal heat gains are very high, air conditioning may be the only solution.

1.1.5 Other constraints

Other factors may affect the window design strategy.

1.1.5.1 Refurbishments

Maintaining and enhancing daylight is essential to good refurbishment (see section 1.2.1). Although it is seldom possible to increase window sizes, they will in many cases be adequate. The design team needs to maximise the opportunities, which include avoiding unnecessary air conditioning through good window design coupled with a natural ventilation strategy. This may in some cases prove more satisfactory to users than air conditioning. New window systems can offer improved opening control, better security, minimise unwanted draughts and, through thoughtful integration of user-controlled blinds, avoid the 'blinds down, lights on' syndrome.

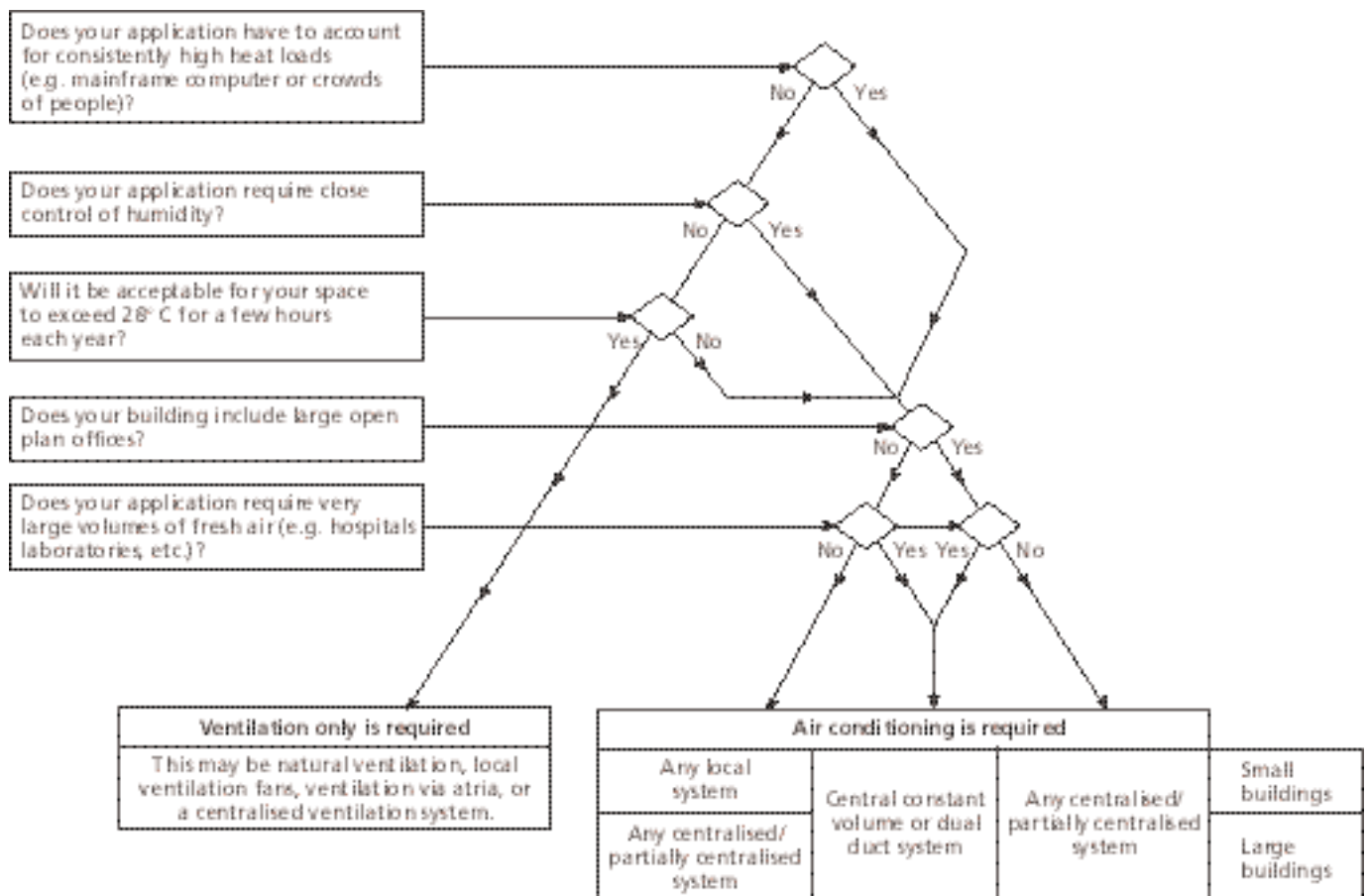

Figure 1.6 Selecting a ventilation strategy

1.1.5.2	<i>Noise</i>	Buildings that are close to a major trunk road, a busy airport or other external noise sources may have problems with noise penetrating the interior through the windows (see section 2.3.11). Normal window glass, because of its low mass, readily transmits noise. There are a number of ways that the problem can be reduced, including minimising the glazing area and placing windows on the quieter side of the building. Very thick glass and double or triple glazed windows with sound-absorbing frame linings are other possibilities. Windows also need to be sealed because noise can penetrate the interior via any gaps around the frame.
1.1.5.3	<i>Exposure</i>	Windows will need to withstand the maximum wind pressure expected on the face of the building: this can range from around 500 N/m ² for a low sheltered area to 8000 N/m ² at the top of a high rise building in the hurricane belt. In some areas, where rooflights are planned, the weight of a layer of snow may need to be considered.
1.1.5.4	<i>Security and impact resistance</i>	Depending on the application of the building and its location, windows may have to provide impact resistance (see section 2.3.8). This may range from a child accidentally running into a window in a school or a football being kicked at a window in a sports hall to vandalism. Large panes of unprotected glass seem to act as a challenge to vandals, and the designer needs to be aware of this potential problem because the replacement of windows is both disruptive and costly. In some special cases, where security is a high priority, very high impact resistance glass will be necessary.
1.2	Windows in the design process	(a) Choose appropriate building form type (see section 1.2.2).
1.2.1	Checklists for design	<p>(b) Review choice of site (see section 2.1.1).</p> <p>(c) Consider building depth (see section 2.1.2).</p> <p>(d) Choose ventilation strategy (see section 1.1.4).</p> <p>(e) Consider building orientation (see section 2.1.3).</p> <p>(f) Consider building positioning and overshadowing of existing buildings nearby (see section 2.1.4).</p> <p>(g) Consider internal layout of building (see section 2.1.5).</p> <p>(h) Go to sidelighting and/or rooflighting checklist below.</p>
1.2.1.1	<i>Sidelit spaces</i>	<p>(a) Check room depth and no-sky line (see section 2.1.2).</p> <p>(b) If both satisfactory, whole space can be daylit; choose window size to meet target average daylight factor (see section 2.2.2).</p> <p>(c) If almost satisfactory, consider daylight redirection (see section 2.3.6). Otherwise, windows are primarily for view (see section 2.2.5).</p> <p>(d) Review thermal implications of window size (see section 2.2.2). If necessary, alter window size or choose different glazing type (see sections 2.3.1 and 2.3.2) or shading devices (see section 2.3.4).</p> <p>(e) Choose ventilation opening area and type (see section 2.2.6).</p> <p>(f) Choose window shape and position to ensure reasonable daylight distribution and view out (see section 2.2.5).</p> <p>(g) Choose appropriate shading devices to control glare and solar gain (see sections 2.3.1, 2.3.2, 2.3.4 and 2.3.6).</p> <p>(h) If the building has visual display units check that a satisfactory environment is provided, with additional shading if necessary (see section 2.3.5).</p> <p>(i) If the building contains objects for conservation check that their requirements are met (see section 2.3.7), with appropriate shading and UV filtering if necessary.</p>

- (j) Choose appropriate window frame or structural glazing system (see section 2.3.9).
- (k) Decide on best electric lighting control strategy (see sections 2.4.1 and 2.4.2).
- (l) Select appropriate lamps (see section 2.4.3).
- (m) Select lighting control type (see section 2.4.4) and specify installation and commissioning (see section 2.4.5).
- 1.2.1.2 *Rooflit spaces*
- (a) Choose appropriate rooflight type (see section 2.2.3).
- (b) Choose rooflight size to meet target average daylight factor (see section 2.2.2).
- (c) Review thermal implications of rooflight size (see section 2.2.2). If necessary, alter rooflight size or type, or choose different glazing type (see sections 2.3.1 and 2.3.2) or shading devices (see section 2.3.4).
- (d) Choose ventilation opening area and type (see section 2.2.6).
- (e) Choose rooflight spacing for required uniformity (see section 2.2.3).
- (f) If rooflights are to an atrium, consider daylighting of spaces off atrium (see section 2.2.4).
- (g) Choose appropriate shading devices to control glare and solar gain (see sections 2.3.1, 2.3.2, 2.3.4 and 2.3.6).
- (h) If building has visual display units check that a satisfactory environment is provided, with additional shading if necessary (see section 2.3.5).
- (i) If building contains objects for conservation check that their requirements are met (see section 2.3.7), with appropriate shading and UV filtering if necessary.
- (j) Choose appropriate rooflight frame or structural glazing system (see section 2.3.9).
- (k) Decide on best electric lighting control strategy (see section 2.4.1 and 2.4.2).
- (l) Select appropriate lamps (see section 2.4.3).
- (m) Select lighting control type (see section 2.4.4) and specify installation and commissioning (see section 2.4.5).
- 1.2.1.3 *Special requirements for refurbishments*
- (a) If the building is too dark, check room depth and no-sky line (see section 2.1.2).
- (b) If not satisfactory, consider rooflights or atrium (checklist above), or improve electric lighting (see section 2.4).
- (c) If both satisfactory, consider increasing internal reflectances (see section 2.2.2), window size (see section 2.2.2) or replacing tinted glazing by clear (see section 2.3.1). Go to sidelit checklist above.
- (d) If there is too much glare, choose appropriate shading devices (see sections 2.3.1, 2.3.2, 2.3.4 and 2.3.6).
- (e) Check the solar gain.
- (f) If there is too much solar gain, choose appropriate shading devices or change glazing type (see sections 2.3.1, 2.3.2, 2.3.4 and 2.3.6). Alternatively, reduce window area. See sidelit checklist above.
- (g) If daylighting of building is good but electric lighting continuously in use, decide on best electric lighting control strategy (see sections 2.4.1 and 2.4.2), select lighting control type (see section 2.4.4) and specify installation and commissioning (see section 2.4.5).

More detailed information for a range of building types is given under 'Building types' in the Bibliography.

- 1.2.2 Building form** Building form has a big impact on the overall daylighting and natural ventilation strategy and needs to be considered as a vital stage in the window design process. A major decision is whether to choose sidelighting, rooflighting or a combination of the two, maybe with an atrium or courtyard. But other issues such as obstructions to the site, depth of rooms and internal layout also affect the daylighting of a building. Section 2.1 gives full details.
- 1.2.2.1 Sidelighting** Sidelighting on its own sets a limit on the depth of building that can be satisfactorily daylighted. In a typical building with a window head height of 2.5 m and room width of 3.75 m, daylight can penetrate about 6 m from the window elevation (see section 2.1.2). This sets a design constraint, producing plans that are about 12 m deep for a dual-aspect building. Increasing the window head height and room width will help. Attempts to increase penetration substantially with light shelves and special glazing types have not been successful, although they can improve uniformity in spaces of medium depth.
- The use of tall windows related to tall spaces allows daylight to reach farther into the space, but many of the great houses of the past were planned around courtyards to provide bilateral daylighting as at Hampton Court in the work of Wren, in a similar manner to the great Palazzos of Rome or Florence.
- 1.2.2.2 Rooflighting** In order to allow buildings of greater depth, the use of rooflighting (see section 2.2.3) was developed to introduce light farther into the interior by means of domes or other rooflight types. The architect Sir John Soane epitomised the use of overhead light in his London House, now the Soane Museum (see Figure 1.7). To house his collection of classical artefacts he introduced light from above, opening up floors to allow the natural light to spill down to the basement below.
- Rooflighting can also be used for specialist types of buildings such as sports halls (see Figure 1.8): they can replace side windows which may cause glare when trying to track projectiles. Rooflights can also cause glare if they are not well designed, but it is often an easier design problem to solve this than reducing the glare from side windows.



Figure 1.7 The Soane Museum, where rooflights are used to great effect in rooms such as the Breakfast Room which would otherwise receive little daylight



Figure 1.8 The sports hall at Mountbatten School in Hampshire achieves good average levels of illuminance with its rooflights and some high level glazing combined with reflective side walls



1.2.2.3 Atria

Atria can introduce light into deep plan designs, as well as providing attractive spaces (see Figure 1.9). Their principal advantages are:

- (a) They admit daylight into deep spaces which would otherwise be far from a window.
- (b) They can introduce an element of spaciousness into a working interior, with attractive internal views, particularly where planting is included.
- (c) They provide visual orientation and a focus for circulation, helping occupants to retain a sense of direction.
- (d) They are potentially energy-saving, reducing heat loss compared with the walls of an equivalent open courtyard. They can also provide ventilation to core areas of the building, with substantial energy savings if air conditioning can be avoided. However, the additional daylight received by adjacent rooms is likely to be small and therefore will have little impact on electric lighting use (see section 2.1.5).
- (e) Interior surfaces are protected from the weather, so walls and windows facing into the atrium need not be weather-tight. This leaves opportunities for acoustic absorption and decorative treatments.

The principal drawbacks of atria are:

- (a) They can take up floor space, on several levels, that would otherwise be occupied. Alternatively, the overall plan area of the building could be reduced.



Figure 1.9 The atrium at the Harlequin Centre, Watford, allows daylight to penetrate far into the interior of the shopping mall

- (b) Although atrium glazing admits abundant daylight, this will not penetrate far into abutting spaces unless the atrium is articulated, in plan and section, to give surrounding interiors a substantial direct view of the sky (see section 2.1.5).

Atria in the UK should not be air conditioned. Experience shows that they are very seldom liable to summertime overheating if through ventilation is provided; the hot air rises above head level and exits through high level vents. Extraction through the top of the atrium reduces overheating in adjacent high-level rooms.

Discretion should be shown with planting in atria. Tropical trees and plants can be very attractive and lend much to the ambience of an atrium, but they often require lighting levels of 1000 lux or more for 12 hours a day and this imposes an energy requirement, particularly in winter. The powerful lamps needed can be obtrusive both to the occupant and to incoming daylight.

In general, the provision of an atrium cannot be justified on energy grounds alone. It will not earn its keep unless there is some other justification for an open gathering space at ground level.

1.2.2.4 Orientation

The orientation of a building façade, and hence the windows within it, has an important bearing on the interior environment. There are two important aspects of this: first, the setting of the building on its site and its relationship with the path of the sun, and secondly enabling people to know where they are within a building. This sense of orientation comes from contact with the world outside, which may be gained from an awareness of the daylight pattern even where there is no view out.

It will not always be possible to provide the optimum orientation where a building is placed in a rigid street network or overshadowed by its neighbours. However, orientation should always be considered to ensure that the most advantageous solution is adopted at the outset. This will clearly be easiest on a greenfield site.

The orientation of the window (see section 2.1.3) to the sun will significantly affect the amount of solar gain and the consequent degree of penetration of sunlight. For instance, a north-facing window will admit little solar radiation compared with one facing south, west or east. For a south-facing façade, the sun is high in the sky at the hottest part of the day in summer and, consequently, solar penetration can effectively be

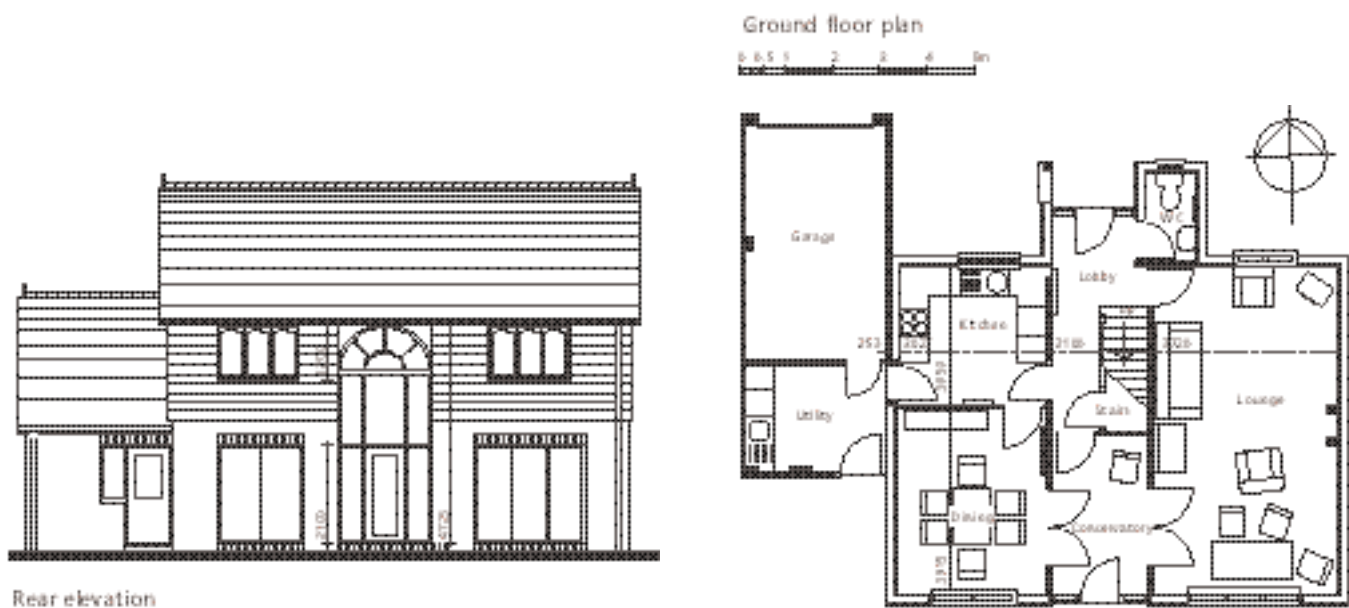

Figure 1.10 A four-bedroomed detached house designed with the larger rooms facing south, while smaller rooms and rooms with heat gains, such as kitchen and bathroom, naturally take their place on the north side

Figure 1.11 The daylight pattern within Bentalls Shopping Centre, Kingston, gives people sense of direction and of the building form even though there is no view out



avoided using shading. For this reason, a preferred orientation for a building will often be with the longer axis aligned east-west, with solar shading on the south face. If overheating is a potential problem — for example, a typical office with high internal gains from equipment — south-west is the worst orientation, because sunlight is not only intense in the spring and autumn but also at a low angle, which makes it difficult to shade.

In a house, sunlight is generally welcome at practically any time of day, provided there is enough thermal mass and natural ventilation to prevent overheating. Where passive solar energy is beneficial, windows on the south side of the building can be increased slightly to optimise the benefits; however, a better strategy is to reduce the glazing on the north elevation to the minimum consistent with good daylight throughout the building (see section 2.1.3). This can have effects on the plan shape (see Figure 1.10).

While a perception of the exterior beyond the building may be of little importance in a large self-evident space, such as a church or swimming pool, it becomes significant where the spaces within the building are complicated (see Figure 1.11). In some of the early windowless shopping centres, for example, it could be difficult for people to find their direction, leading to disorientation.

1.2.3 Window size and position

The human visual process has the capacity to adapt to a wide range of light levels, but it requires a minimum level to see particular task details. Daylighting, though, is more than lighting tasks: it is also about lighting spaces so that they are pleasant to be in. In general, people prefer spaces to appear bright; 'light and airy' is a common description. To create this effect the window area must provide sufficient light and the windows be placed in positions where they illuminate building surfaces, particularly the walls which form a major element in the normal field of view.

Window area not only affects the amount of daylight but also influences heat gain and heat loss (see section 2.2.2). The daylight and thermal conditions are often in conflict with one another: that is, the greater the window area the greater the amount of daylight, but also the greater the heat loss and heat gain unless other elements are introduced to counter these effects.

The Building Regulations Part L: Conservation of Fuel and Power (Part F in Scotland and Part J in Northern Ireland) recommend minimum standards of thermal insulation of the fabric and maximum areas of double glazing in walls and roofs. In some cases, this maximum area may be less than that found necessary for effective daylighting. Approved procedures are specified in the Regulations which allow these glazed areas to be increased.



Figure 1.12 The windows of this 14th century hall in Hampshire are representative of the tall windows (unglazed at the time) of the domestic architecture of the period, and the daylit interior illustrates the warmth of the internal stonework.

Window location has more than purely aesthetic repercussions. The placing of windows in the façade can greatly affect view out, glare and daylight distribution (see section 2.2.5). High windows are most efficient at letting in daylight, particularly into the deeper part of the plan, and the aperture is less obstructed by other buildings, trees and the ground. The more sky that can be seen, the better the daylight, and high windows are best for this. Figure 1.12 shows an example of this in a 14th century building.

The benefits of high level glazing need balancing against the higher sky glare. If glare is a problem, however, this may be alleviated with internal or external shades, or light shelves. Compared with windows in normal positions, high level windows can let in more light, or they can be made smaller, reducing energy costs. It will also generally be essential to provide some lower windows so that external views can be appreciated (see Figure 1.13).

The location and detailed form of windows can be arranged to produce unusual or dramatic visual effects. In the Baroque churches of Southern



Figure 1.13 De Montfort Engineering Building, Leicester, maximises daylight by incorporating high windows; light shelves reduce glare. Smaller windows provide a view for individuals sitting at the workstations



Figure 1.14 Die Weiss, typical of the Baroque churches of Southern Germany where daylight enters from windows concealed from normal points of view, focusing light on to the altar



Germany, typical of which is Die Weiss, the natural source of light enters mostly from windows concealed from normal points of view, focusing light on to the altar (see Figure 1.14). In Zweifalton Abbey, the structure acts as giant louvres to baffle the windows, excluding glare from the view of the congregation.

1.2.4 Window components: glazing and shading

The use of glass infill for windows was not common before the end of the 15th century in Europe. Windows were left as unglazed openings or filled with a variety of materials which admitted daylight, such as mica, oiled linen or parchment. Churches led the way with stained glass, telling the Christian story, but daylight design really developed with the great cathedrals of the 12th and 13th centuries. The structural innovation of the flying buttress allowed walls of glass to be placed between, providing interiors full of skylight and sunlight, which we enjoy today.

The maximum size of panes of window glass was initially limited to about 300 mm, leading to multiple panes set together to form large areas of leaded lights. Larger panes developed in the 18th century made possible the Georgian window; but it was the manufacturing processes invented after the First World War which extended the possibilities of glass (see section 2.3.1), coinciding with the revolution in structure which led to buildings with whole walls of glass being constructed.

Modern types of glazing, combined with the provision of shading devices, can counteract the thermal consequences of the window design. For example, solar control glasses can help reduce solar gain (see section 2.3.2). They selectively reflect or absorb the high energy radiation in sunlight, so minimising its impact on the internal environment. Many solar control glasses, however, reduce daylight transmission or distort the colour of the external view, which can be a source of annoyance particularly where open windows reveal the contrast. They also have little impact on glare from the sun although they can reduce sky glare. Solar gain is more effectively mitigated by the use of glasses with selective coatings which are visually clear and provide good heat/light ratios.



Figure 1.15 The Queens Building, Anglia Polytechnic, has light shelves on the outside façade and inside the atrium

Solar gain can also be controlled with various shading devices and architectural features such as overhangs or recessing the window in the façade (see section 2.3.4). Fixed light shelves (see section 2.3.6) can provide similar benefits and a more even distribution of light, thus reducing light contrast; they do need to be carefully designed, however, in order to achieve their intended purpose (see Figure 1.15).

To control solar and sky glare, shading devices such as blinds will be needed. Interiors with visual display terminals present special problems here (see section 2.3.5).

The choice of window type influences heat loss. Normal clear single glass has a relatively high heat transmittance. This means that in winter, heat from the interior may be lost to the outside. Also the area near a window may feel cool due to a down draft of air which has been cooled by a cold glass surface. Condensation may also be a problem where moisture-laden warm air comes into contact with cold glass and produces the familiar damp haze.

These problems can be reduced, or even eradicated, by using double or triple glazing. Further improvements can be achieved by using a double glazed unit that incorporates a heat-reflecting coating combined with an inert gas filling between the two panes of glass. This type of glazing has the added benefit of having a high light transmittance (see section 2.3.2).

1.2.5 Lighting and controls

When daylight fades, electric lighting will need to be introduced. At first it will complement the daylight by 'topping up' the task illuminance, and then take over completely as night falls. The daylighting and electric lighting will therefore need to be an integrated part of the overall lighting solution, complementing each other for function, appearance and energy efficiency.

A building that is well daylit and needs little electric light for much of the year provides a good basis for an energy-efficient building. However this requires the provision of suitable environmental controls, including electric lighting controls (see section 2.4), blinds and other adjustable shading devices (see section 2.3.4), opening windows (see section 2.2.6)

and heating controls. In most spaces, individual occupant controls are the most successful, because:

- people value control over their own environment; if they have such control they will tolerate a wider range of environmental conditions
- there can be differences in optimum comfort conditions between individuals
- in many buildings, people carry out a range of tasks with different visual and sometimes thermal requirements.

However such controls need to be designed and installed with care. They must:

- respond quickly to user preferences
- be easy and logical to operate
- provide feedback to users that the control is working
- be adaptable if patterns of use or the internal layout of the building change
- be commissioned and maintained with care.

1.2.6 Conclusion

Windows in all their forms, in walls or roofs, are a fundamental element of buildings. They enable people to see to carry out tasks but they also provide pleasure through the constantly changing intensity, pattern and colour of light. Daylight comprises diffuse light from the sky and direct light from the sun which provide lighting to define and model an interior and its contents. Windows also provide a view out giving visual variety and stimulation but may cause problems of privacy. However, they can create problems of thermal and visual discomfort as well as noise intrusion. The designer will need to consider all these aspects, balancing one against another to ensure a successful window design solution for the particular building type, application and site location.

2 Design

2.1 Siting and massing: building form and layout

Effective daylight design must start at the site layout stage, before windows are considered in detail. This is because large obstructions may have an impact both on the amount of light reaching windows and on the distribution of light within a room. Site layout is also the most important factor affecting the availability of sunlight inside a building. For effective passive solar design, making the most of winter solar gains, it is especially important that the degree of obstruction of the site is considered.

2.1.1 Site characteristics

2.1.1.1 Site slope

A south-facing slope will experience higher temperatures than a north-facing slope, and is likely to be sheltered from cold northerly winds as well as receiving increased solar radiation. Conversely, a north-facing slope will probably be colder, exposed to northerly winds and receive reduced solar radiation. Site slope of any direction will reduce the amount of daylight reaching windows that face up the slope⁽²⁾. Figure 2.1 shows how this increases the building spacing needed to give the same daylight illuminances on the window wall.

Yannas⁽³⁾ tabulates the required spacing for solar access for rows of dwellings on level ground and on north- and south-facing slopes. A north-facing slope makes it very difficult to achieve good sunlight access in winter, which will rule out passive solar space heating as a strategy.

In exposed positions⁽⁴⁾, fewer and smaller openings will be required if the site is subject to strong winds or the proposed building will be much taller than its surroundings. Openings should also be carefully weather-stripped^(5, 6).

(a) Level site

(b) Sloping site



Figure 2.1 Overshading is less of a problem on a flat site (a) than on a sloping site (b). If there is a slope, buildings must be spaced farther apart in order to obtain the same access to daylight as buildings on a flat site

2.1.1.2 Atmospheric pollution

In very dirty or polluted locations, sealed windows and mechanical ventilation or air conditioning may be necessary. Alternatively, it may be possible to admit natural ventilation from a less polluted side of the building. Dirt deposits on windows may require extra glazing or a rigorous programme of maintenance (see section 2.2.7). Horizontal rooflights become dirty very quickly and need to be cleaned frequently, and for this reason should be avoided in dirty or polluted places. Sloping glazing also become dirty more quickly than vertical windows.

2.1.1.3 Noise

In very noisy locations, careful detailed design of windows is necessary^(7, 8) (see section 2.3.11). Double glazing can give protection but careful sealing around the edge of the unit is essential to avoid air gaps through which sound can pass. Sound insulation can be improved further using laminated or thicker glass, sound-absorbing material on the internal reveals of the double glazed unit and non-parallel window panes.

The main conflict is between acoustic protection and ventilation. An open window gives very little sound insulation while trickle vents tend to reduce the performance of a double glazed unit to that of a single glazed window. It may be possible to admit ventilation air from a quieter side of the building (if there is one) or to site acoustically sensitive tasks on the quieter side. In extreme cases, mechanical ventilation through specially designed vents may be necessary.

2.1.1.4 Overshadowing and site obstruction

The availability of daylight and solar gain will be reduced if the site is heavily obstructed (see section 2.1.4).

2.1.2 Building depth and overall size

If a multistorey building is to be completely lit by daylight, there will be limits on its overall plan depth. These can be calculated using the following procedure. First, find the limiting room depth. If a daylighted room is lit by windows in one wall only, the depth of the room L should not exceed the limiting value given by

$$L/W + L/H_w < 2/(1-R_b) \quad (2.1)$$

where W is the room width, H_w the window head height above floor level and R_b the average reflectance of surfaces in the rear half of the room (away from the window). If L exceeds this value, the rear half of the room

Table 2.1 Limiting depths of sidelit rooms (in metres)

Reflectance R_b	0.4	0.4	0.5	0.5	0.6	0.6
Room width (m)	3	10	3	10	3	10
Window head height (m)						
2.5	4.5	6.7	5.4	8.0	6.8	10.0
3	5.0	7.7	6.0	9.2	7.5	11.5
3.5	5.4	8.6	6.5	10.4	8.1	13.0

will tend to look gloomy and supplementary electric lighting will be required.

Table 2.1 gives values of the maximum depth for different room widths and window head heights, and for different reflectances at the back of the room. Higher reflectances and higher window heads allow deeper rooms. For wider rooms, the allowable depth is markedly greater. For instance, for rooms of 3 m width with 2.5 m window head height and 0.4 reflectance, the maximum depth is 4.5 m. If the same room had 0.6 reflectance, the maximum depth increases to 6.8 m; and if it had a window head height of 3.5 m, the maximum depth would be 5.4 m with 0.4 reflectance and 8.1 m with 0.6 reflectance.

If a building is lit by windows on two opposite sides, the maximum depth that can be satisfactorily daylit is twice the limiting room depth L , from window wall to window wall.

2.1.2.1 No-sky line

If a significant area of the working plane lies beyond the no-sky line (i.e. it receives no direct skylight), the distribution of daylight in the room will look poor and supplementary electric lighting will be required. The no-sky line position can be altered by increasing the window head height or by setting the building façade back from obstructions (see below).

If the room and its external obstructions already exist, the position of the no-sky line can be measured directly (see Figure 2.2), but in most cases its position has to be found from drawings. Figures 2.3-2.5 illustrate some common cases.

- (a) Long horizontal obstruction parallel to window (see Figure 2.3). The no-sky line is also parallel to the window.
- (b) Narrower horizontal obstruction parallel to window (see Figure 2.4). CD is part of the same no-sky line as in Figure 2.3, but now points north of DE can receive light around corner A of the obstruction, and points south of CF can receive light around

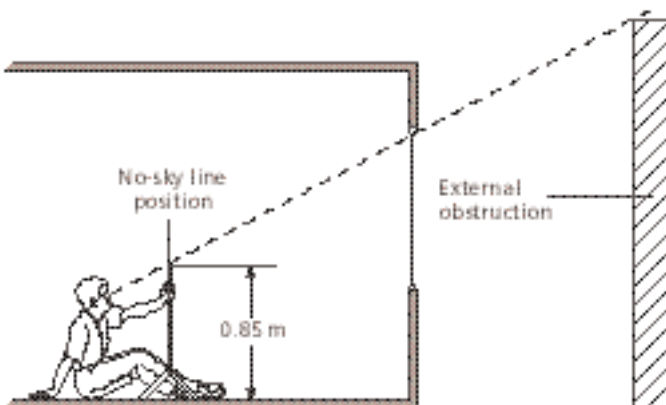

Figure 2.2 At the no-sky line, the last visible patch of sky above the obstruction will just disappear when the window head is sighted through a point at working plane height

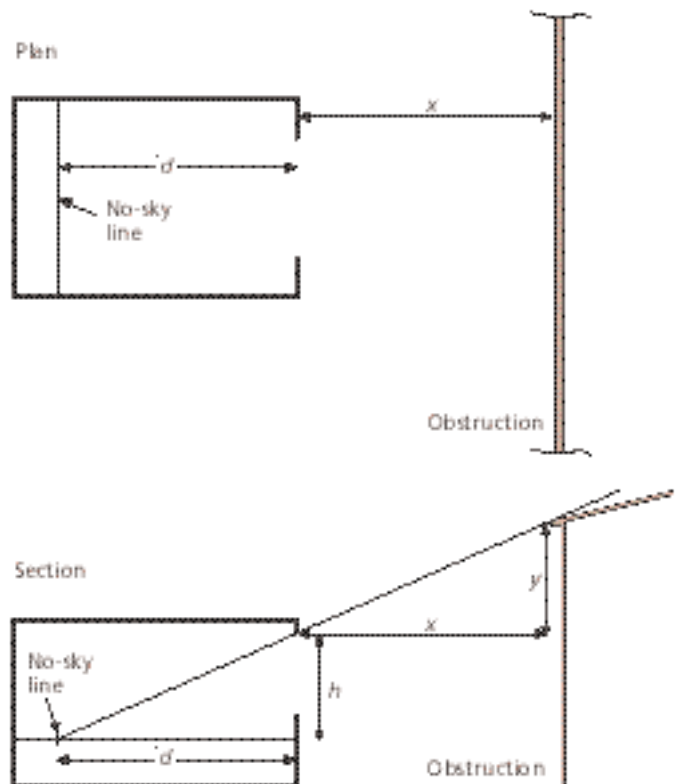

Figure 2.3 For a long obstruction parallel to the window, the no-sky line is also parallel to the window. Its position can be found from the section

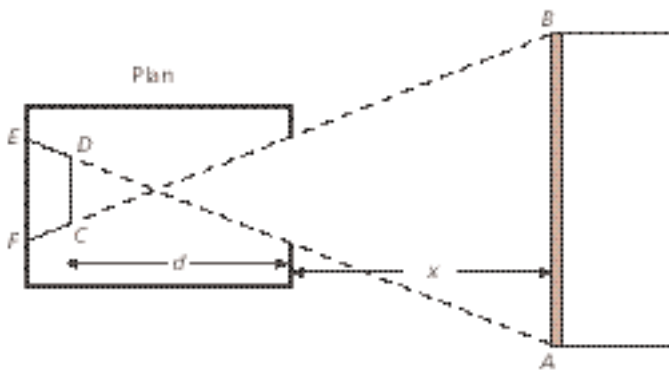

Figure 2.4 The no-sky area for a narrower obstruction is bounded by lines through the sides of the window and the vertical ends of the obstruction

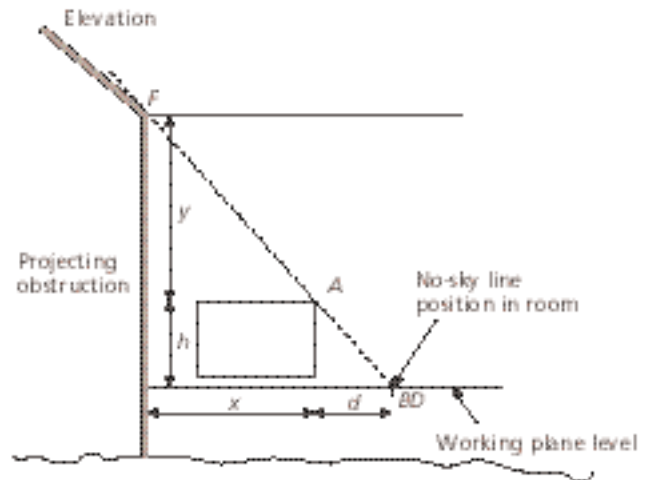
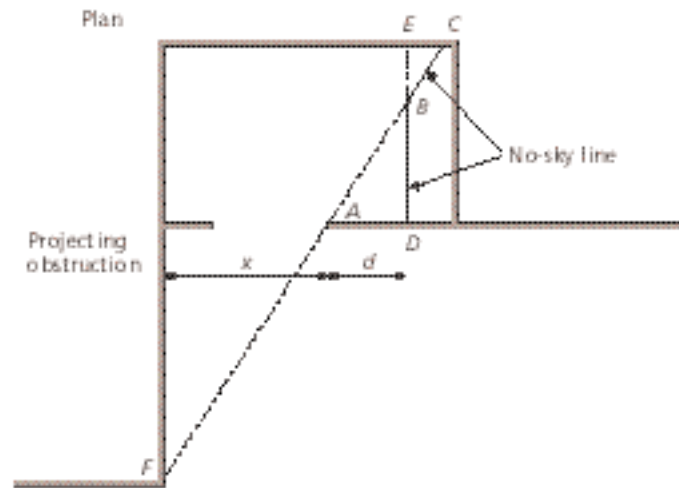

Figure 2.5 For an obstruction projecting from the window wall, the no-sky line runs partly parallel to the obstruction and partly along a continuation of the line joining the end of the obstruction F and the side of the window A

corner B . So the no-sky area is in the form of a trapezium. If the obstruction AB had been even narrower, the no-sky area would be triangular in shape, and in the same position even if the obstruction were higher.

In plotting the no-sky line, the key points are the top corners of the window. These are usually the last points at which sky can be seen.

- (c) Horizontal obstruction perpendicular to window wall and projecting from it (see Figure 2.5). Part of the no-sky line (DB) runs parallel to the obstruction. However, points in the triangle EBC can receive skylight around the corner F ; points in the triangle ABD can 'see' sky over the top of the obstruction. The figure assumes that the window wall is negligibly thin. If the window wall is thick, the no-sky area will be larger.

Where there is more than one window, the final no-sky line will surround those areas which cannot receive direct skylight from any of the windows. This can be arrived at by considering each window on its own, then combining them. For a room with windows on more than one side it is often the case that all points on the working plane receive direct skylight through one window or another.

The no-sky line and limiting room depths on each side will set a limit to the depth of building that can be satisfactorily daylight. If the building needs to be deeper than this, the options are:

- rooflighting
- an atrium or courtyard space
- a non-daylit core with daylight perimeter.

2.1.2.2 Case study: no-sky lines in a proposed building

An office is to be built on the site shown in Figure 2.6. It will have five floors. Floor-ceiling height will be 2.7 m and floor-floor height will be 3.3 m. A typical module width is 12 m. The client wants the whole building to be daylight. Can this be achieved?

First, we calculate the limiting depth L for spaces lit from one side. Using equation 2.1 and taking $Rb=0.5$, $W=12$ and $H_w=2.7$, gives a limiting depth of

$$L/12 + L/2.7 < 4$$

$$\text{So, } 0.083L + 0.370L < 4$$

$$L < 4/0.453 = 8.8 \text{ m}$$

Thus if the office were completely unobstructed on both sides it could be 17.6 m wide, nearly filling the site. On the north side, however, the obstructing building will affect the position of the no-sky line. On the ground floor, Figure 2.7 shows that only the first 2 m can be satisfactorily daylighted if the whole of the site is used. This leaves $18 - 8.8 - 2 = 7.2$ m of effectively non-daylit space. This area would be less on the upper floors.

If the whole of the building is to be daylight, three options are:

- (a) Set back the northern side of the building; Figure 2.8 shows how this can be done. The limiting position of the northern side is found by drawing upwards from the last daylight point on the southern side towards the obstruction to the north. To avoid a poorly daylighted area this line should intersect the northern façade at or below window head height.
- (b) Include an atrium; Figure 2.9 shows a possible layout.
- (c) Increase the ceiling height, and hence window head height, on the lower floors (see Figure 2.10). For example, a 4 m ceiling on the ground floor would give a daylighted area of 12 m to the south and 3.6 m to the north, leaving only 2.4 m non-daylit. This illustrates the importance of window head height; in these examples, the depth of daylighting would be significantly less if the window head were below the ceiling.

Note that in this case study, particularly options (b) and (c), the impact on the neighbouring building would need to be analysed (see section 2.1.4).

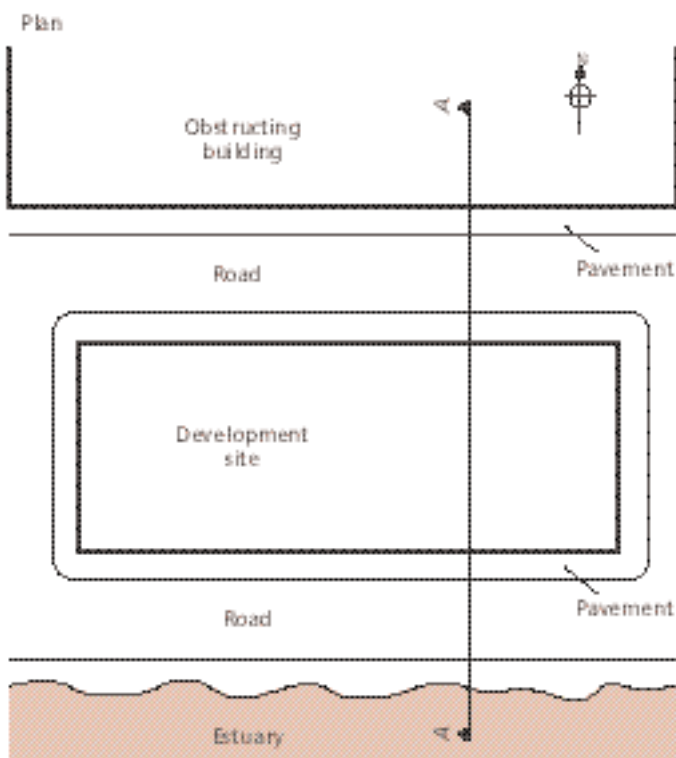

Figure 2.6 Plan and section views of a development site for the office building

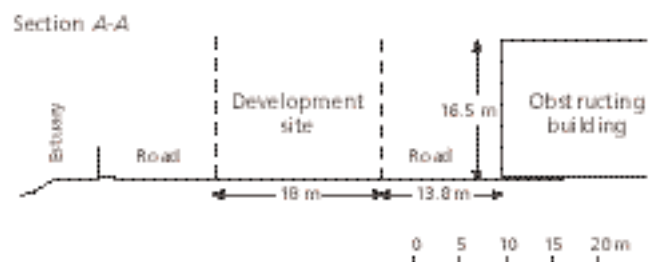

Figure 2.7 Daylight zones on the ground floor of an 18-m wide building. The obstructing building to the north of the site will affect the position of the no-sky line. On the ground floor, only the first 2 m on the side facing the obstruction can be satisfactorily daylighted if the whole of the site is used

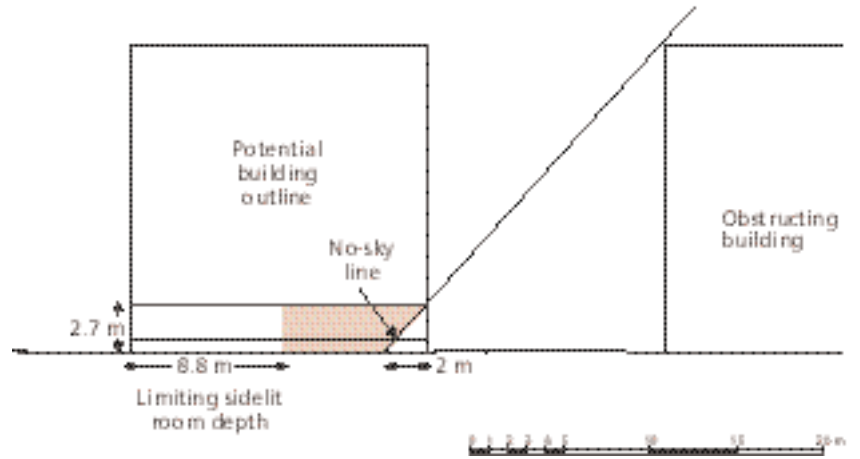

Figure 2.8 The northern side of the building is set back to give a narrower building. Most of the ground floor is daylighted: to achieve complete daylighting the northern side would have to be set back even farther

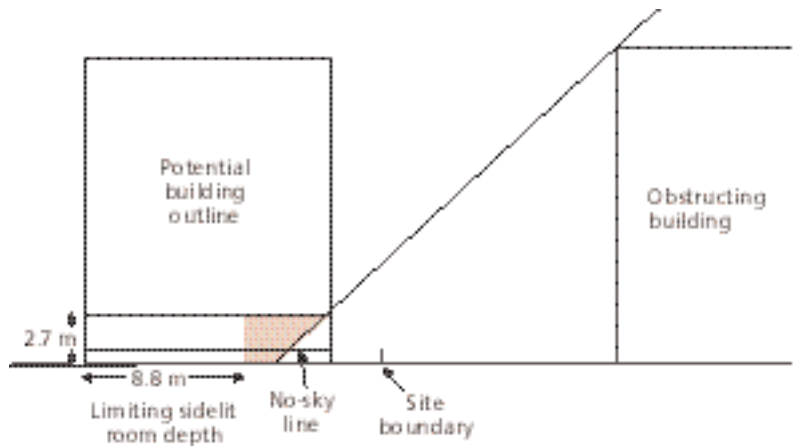

Figure 2.9 A building with an atrium. The south side of the atrium has been splayed back to achieve a larger area of daylight space in the northern wing. However this wing is still narrow; perhaps the site is not big enough for an atrium building

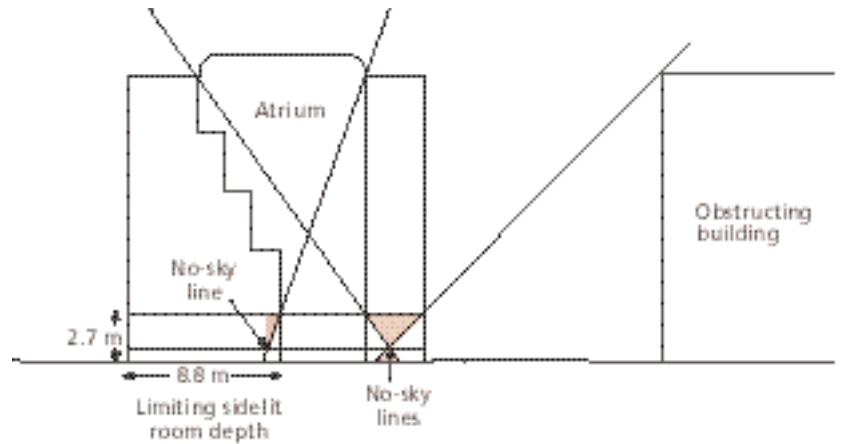
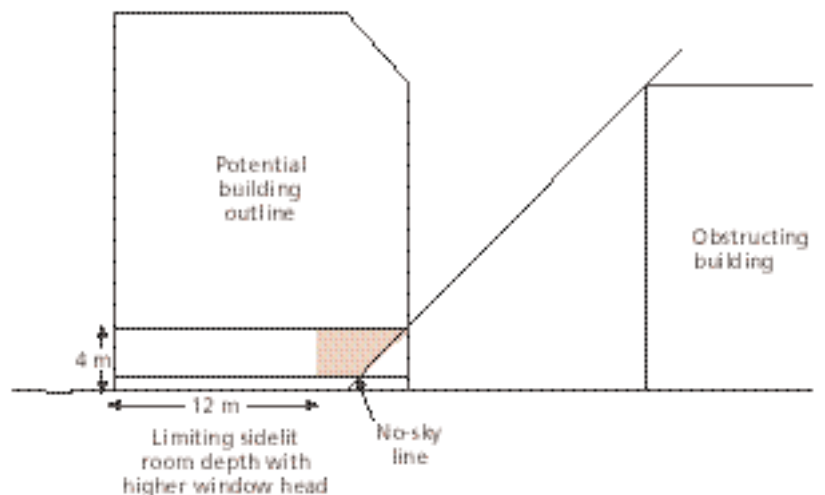

Figure 2.10 A building with higher ceilings and window heads, leaving only 2.4 m that is not satisfactorily daylighted



2.1.3 Building orientation

In the northern hemisphere, for a space to have good access to sunlight for amenity purposes, its window wall should face within 90° of due south.

For a building to make the most of passive solar heating, its main window wall should face within 30° of due south. In non-domestic buildings, a slightly more easterly orientation may be beneficial in providing solar heat in the morning and avoiding afternoon overheating in summer.

In general, a building whose main window walls face north and south (with a long east-west axis) will be easier to shade. Effective shading of an east- or west-facing façade is less easy because the sun is lower when it is opposite the windows.

The effects of obstructions and orientation on sunlight availability can be found using a sunpath diagram. Figure 2.11 shows an example of a stereographic sunpath diagram for latitude 51°; Moore⁽⁹⁾ gives diagrams for other latitudes up to 52°. This diagram is a projection of the whole sky; the horizon is represented by the outer circle and the zenith (the sky directly overhead) by the point in the centre. Concentric circles represent lines of constant elevation above the horizon. The scale around the perimeter gives azimuth, the bearing in degrees from north.

The monthly sunpath lines represent the 21st day of each month: the highest is midsummer, the lowest midwinter. The March-September line shows the equinox, with the sun rising due east at 6 am and setting due west at 6 pm. The diagram is in solar time which in the UK approximates to Greenwich Mean Time. In summer, add one hour to get British Summer Time.

On the diagram, horizontal edges plot as arcs of circles and vertical edges as radial lines. Figure 2.12 shows an example building layout, an L-shaped building 20 m high. The times when the building shades the point marked 'Viewer position' are required. On the sunpath diagram, the building outline is plotted by first measuring:

- the distance, x , from the viewer to each corner of the obstructing building
- the azimuth angle α , or bearing from north of each corner.

The distance x is then used to find the angle γ of elevation above the horizon of each skyline corner. If h is the height of the obstructing building above the viewer position

$$\gamma = \arctan(h/x)$$

Table 2.2 gives the values for the example. These points are then plotted using their angles on Figure 2.11, giving an outline of the building (see Figure 2.13). On a stereographic drawing, a horizontal skyline is transformed into a curve, so it is useful to take an intermediate point (d in this example) to help draw this accurately.

Table 2.2 Angle γ of elevation above the horizon for each skyline corner. The height of the building, h , is 20 m

Point	x (distance from viewer)	α (azimuth degrees from north)	γ (elevation above horizon)
<i>a</i>	28 m	290°	35°
<i>b</i>	20 m	280°	45°
<i>c</i>	26 m	265°	38°
<i>d</i>	20 m	225°	45°
<i>e</i>	23 m	195°	41°

Figure 2.13 shows that in the winter months, September to March, the sun would be obstructed from about 1 pm solar time. During the summer it would dip behind the skyline of the building during the afternoon, in April and August at about 2 pm and in mid-June at about 4 pm. On June evenings, the sun would reappear from behind the building at about 6.30 pm and stay visible until sunset.

A sunpath diagram can also be used to read off the sun's elevation and azimuth at a given time. These angles can then be used to plot a shadow on the site plan. Figure 2.14 is an example and shows the shadow that would occur at 3.30 pm solar time in mid-June. This shadow just reaches the site boundary at the viewer position.

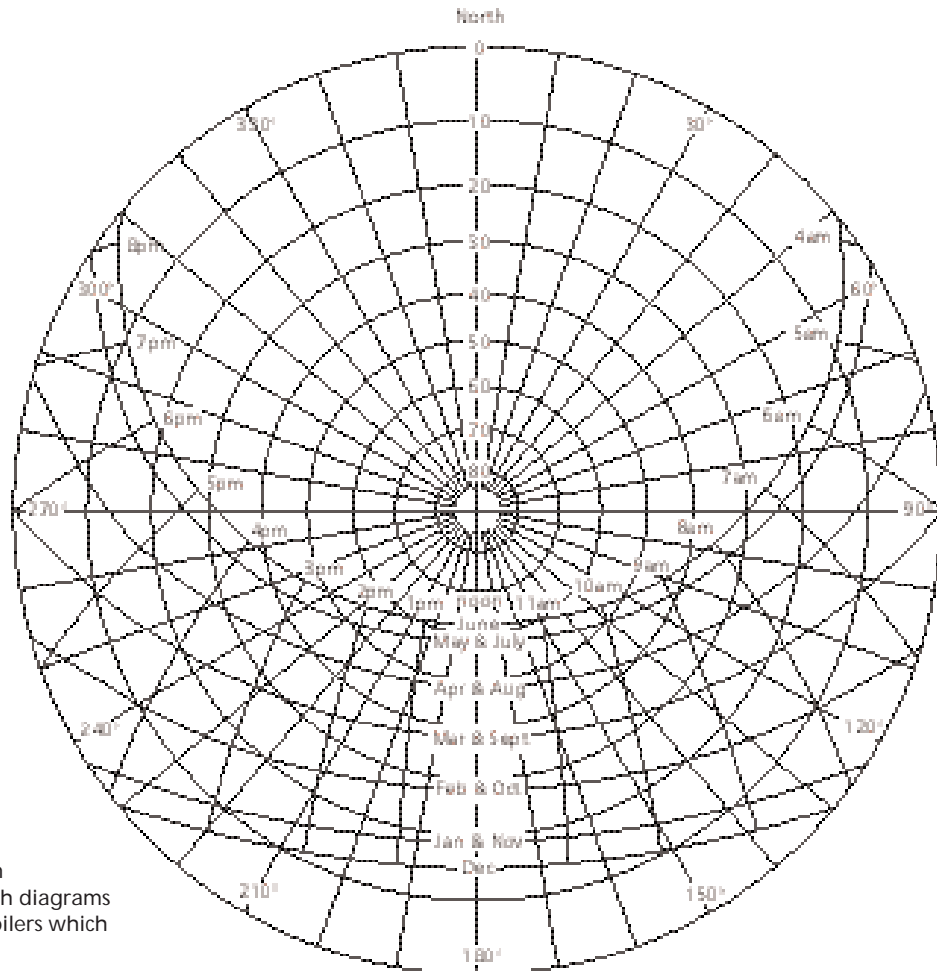

Figure 2.11 Sunpath diagram for London, latitude 51°N. Such diagrams are available from other compilers which cover latitudes above 52°

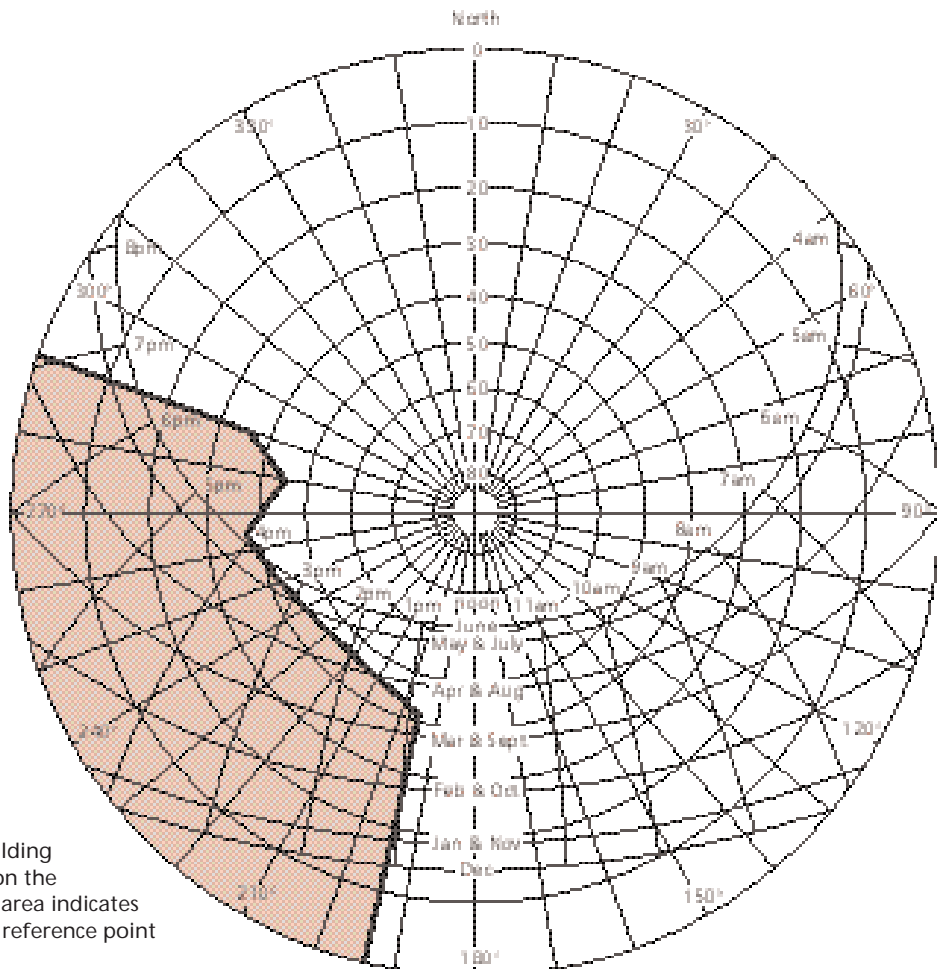

Figure 2.13 The L-shaped building shown in Figure 2.12 plotted on the sunpath diagram. The shaded area indicates the times and dates when the reference point will not receive sunlight

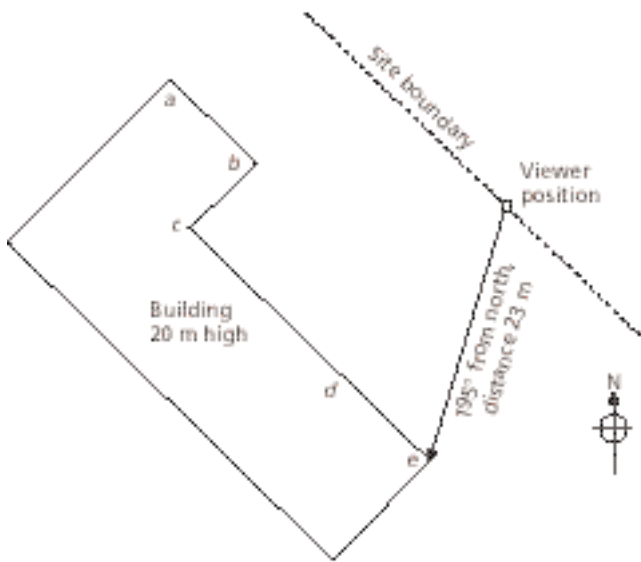

Figure 2.12 Plan of an L-shaped building in relation to viewing position on site

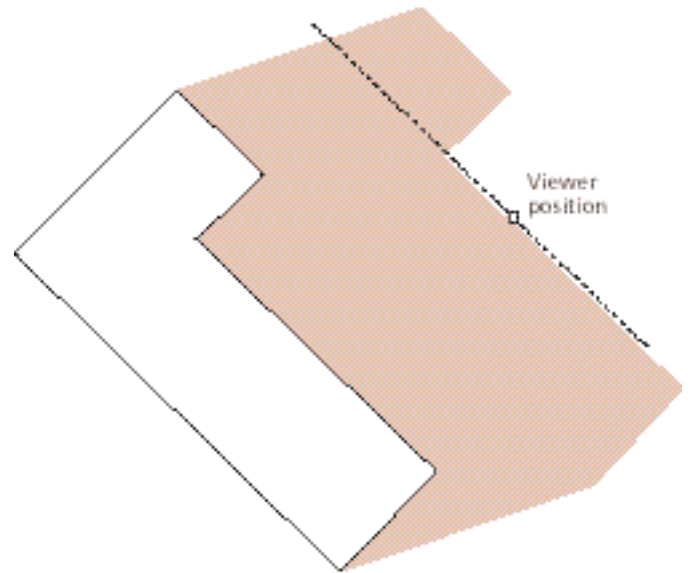

Figure 2.14 Site shadow at 3.30pm in mid June

2.1.3.1 Case study

The Collège la Vanoise in Modane, France, is sited in the French Alps (see Figure 2.15) and is designed to provide an attractive internal environment with good daylighting. Although the elongated site suggests a long building with east- and west-facing window walls, the architect has instead provided a series of north- and south-facing classroom blocks, linked by a covered ‘street’ which runs nearly north-south (see Figure 2.16). The classroom windows can receive views up and down the valley, and are easier to shade from the hot summer sun using overhangs. Note that solar altitudes in Modane (45°N) are 8° higher at noon than in most of the UK, so the classrooms can be more closely spaced. The south-facing ones are fitted with reflective window sills to provide extra light (see Figure 2.17). In the winter, heavy snow often means the children cannot go out to play: instead, they can spend lunch and break times in linear atria between the classrooms (see Figure 2.18) and in the covered street. All the circulation is indoors to protect against bad weather.



Figure 2.15 Collège La Vanoise in the French Alps

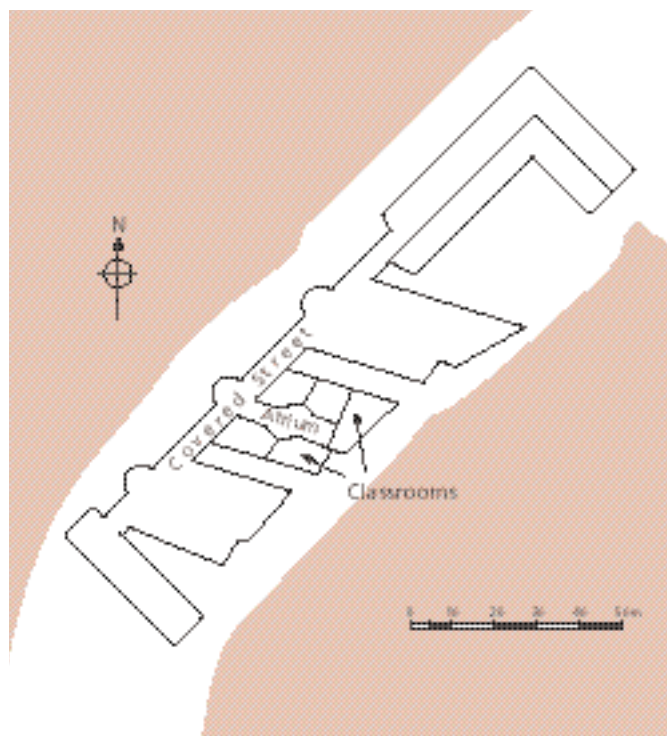

Figure 2.16 Site plan of the school



Figure 2.17 Reflective window sills provide extra light on the south-facing windows



Figure 2.18 One of the linear atria between the classrooms

2.1.4 Building positioning

For good daylighting (see section 2.2), buildings should not be placed too near large obstructions. As a first check, draw a section in a plane perpendicular to each main face of the building (see Figure 2.1 on page 16). If none of the obstructing buildings subtends, at a 2 m reference height, an angle of greater than 25° to the horizontal there will be potential for good daylighting in the interior.

If an obstructing building is taller than this, good daylighting may still be achievable provided that the obstruction is not continuous and is narrow enough to allow adequate daylight around its sides. The amount of skylight falling on a vertical wall or window can be quantified as the vertical sky component⁽²⁾. For a room with non-continuous obstructions there is the potential for good daylighting provided that the vertical sky component, at the window position 2 m above ground, is not less than 27%. This is the value for a continuous obstruction of altitude 25° . A technique for determining vertical sky component is given in section 2.1.4.1.

Obstructions also reduce access to sunlight. *BS 8206 Part 2: Code of practice for daylighting*⁽¹⁰⁾ recommends that interiors where the occupants expect sunlight should receive at least 25% of annual probable sunlight hours, including in the winter months between 21 September and 21 March at least 5% of annual probable sunlight hours. Here 'probable sunlight hours' means the total number of hours in the year that the sun is expected to shine on unobstructed ground, allowing for average levels of cloudiness for the location in question. BRE Report BR209⁽²⁾ provides a method to calculate hours of sunlight received.

It is not always necessary to do a full calculation to check sunlight potential. The BS 8206 criterion is met provided that the window wall faces within 90° of due south and no obstruction, measured in the section perpendicular to the window wall, subtends an angle of more than 25° to the horizontal (see Figure 2.1). (NB obstructions within 90° of due north of the window need not count here.)

2.1.4.1 Case study: how much light does a window receive?

The daylight available in a room is proportional to the amount of light the window receives. This will in turn depend on how heavily obstructed the window is. The calculation is usually made under overcast conditions, when least light is available.

For a window with a wide continuous obstruction, the skylight received is roughly proportional to θ , the angle of visible sky⁽¹¹⁾. θ is measured from

Figure 2.19 The visible sky angle θ is measured from the centre of the window, in the vertical plane perpendicular to it

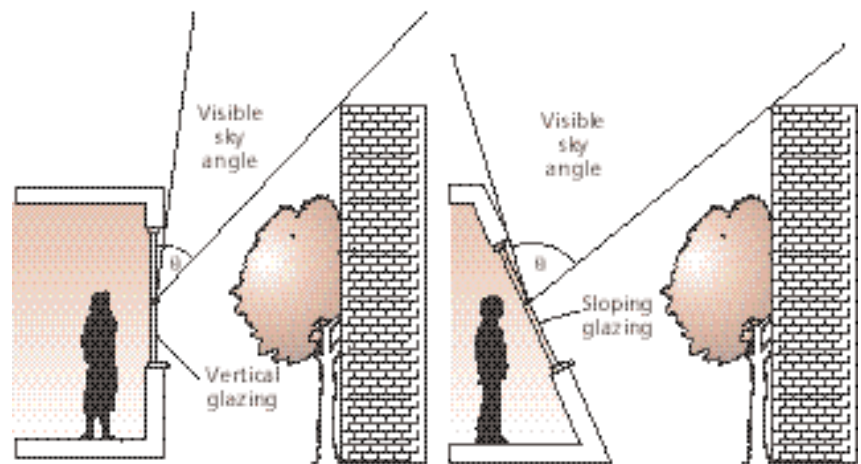

the centre of the window, in the vertical plane perpendicular to it (see Figure 2.19). If there is no overhang, θ equals 90° minus the obstruction angle. So with a 25° obstruction, θ would be 65° .

Where the obstructions are not continuous, their impact can be found by calculating the vertical sky component. This is the illuminance on the outside of the vertical window due to light coming directly from the overcast sky, expressed as a percentage of the light falling on unobstructed ground. The maximum value is just under 40% for a completely unobstructed window. It can be calculated using a skylight indicator (see Figure 2.20).

The skylight indicator has 80 crosses marked on it. Each of these corresponds to 0.5% vertical sky component. The indicator is semi-circular and the centre of the circular arc corresponds to the reference point at which the calculation is carried out. Radial distances from this point correspond to the ratio of the distance of the obstruction on plan divided by its height above the reference point. So if the reference point was 2 m above ground, and the ground was flat, this height would be the obstruction height above ground, minus 2 m. Directions on the indicator from the central point correspond to directions on the site plan. The skylight indicator is used with its straight base parallel to the window wall.

The indicator is not intended to be laid over standard scale site plans because the distance scale on the indicator is unlikely to correspond to the scale of the plan. To plot a layout on the indicator a transparent direction finder may be used⁽²⁾. This looks similar to the skylight indicator. Alternatively, a plan may be specially drawn on tracing paper or acetate to the exact scale of the indicator. This depends on h , the height of the obstruction (in metres) above the reference point for the calculation. The plan should be drawn to a scale of $1:100 h$. Figure 2.21 shows a typical site layout, of a courtyard building 10 m high. The vertical sky component is needed at point O , at a window location 2 m above ground. Thus the appropriate scale is 1:800. Figure 2.22 shows it plotted to this scale and laid over the skylight indicator (both parts reduced in size for publication here). The small obstruction at a different height is drawn to a different scale distance. If a cross lies nearer to the centre of the indicator than any obstruction in that direction (as marked on the direction finder or special site plan) then it is unobstructed and counts towards the total vertical sky component. If it lies beyond the obstruction, it will be obstructed and does not count. The unobstructed crosses are counted up and the number divided by two to obtain the vertical sky component.

From the vertical sky component it is possible to calculate an equivalent angle of visible sky θ for use in the formula for average daylight factor (equation 2.2 in section 2.2.2). Table 2.3 gives the values. This is especially useful for non-continuous obstructions where θ might otherwise be hard to estimate.

Table 2.3 Values of angle θ for different obstruction angles and vertical sky components

Vertical sky component at centre of window (%)	Value of θ in average daylight factor equation
40	90
38	85
35	80
33	75
30	70
27	65
24	60
21	55
18	50
15	45
13	40
10	35

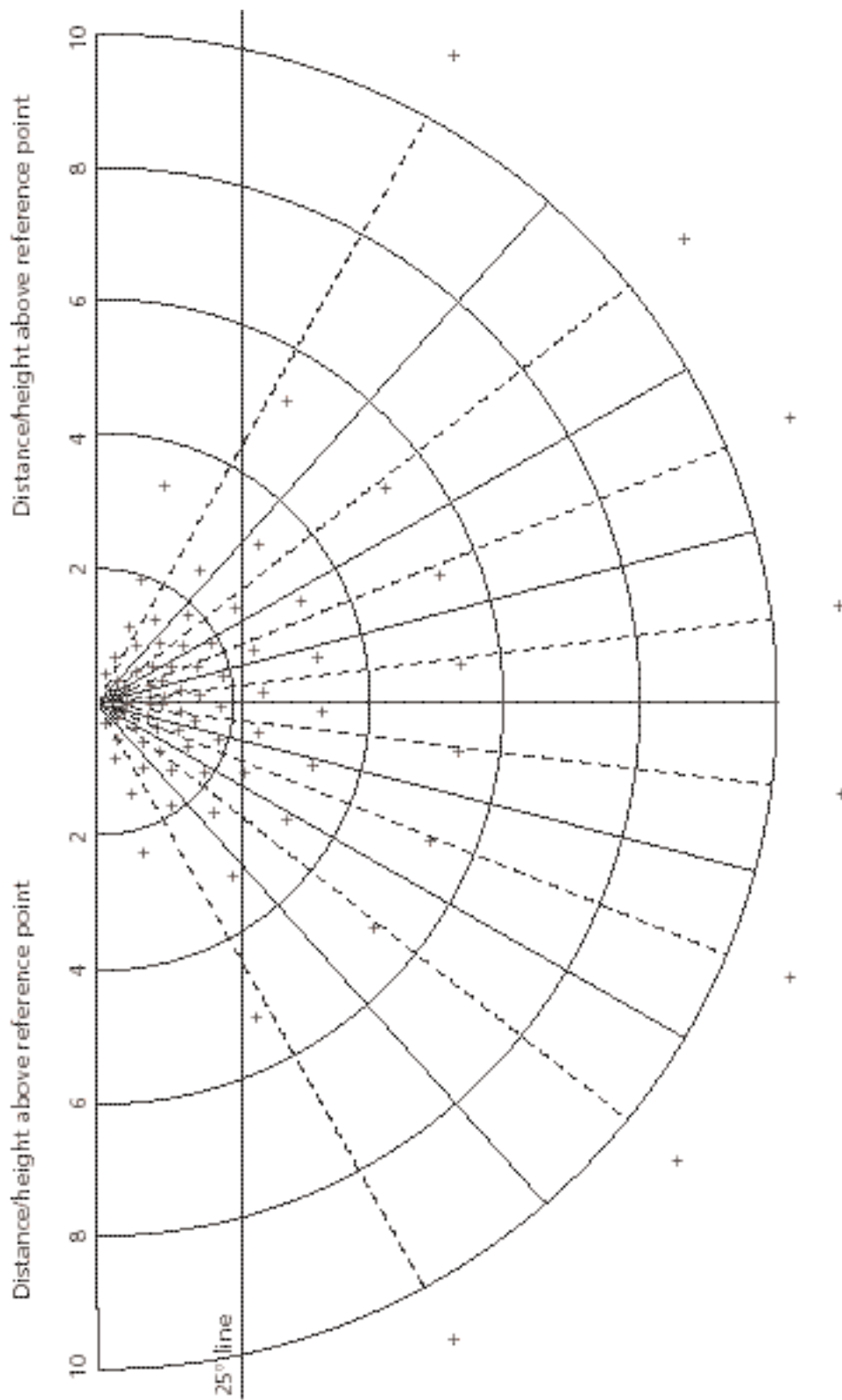

Figure 2.20 Skylight indicator for calculation of vertical sky component



Figure 2.21 Site plan of an example situation

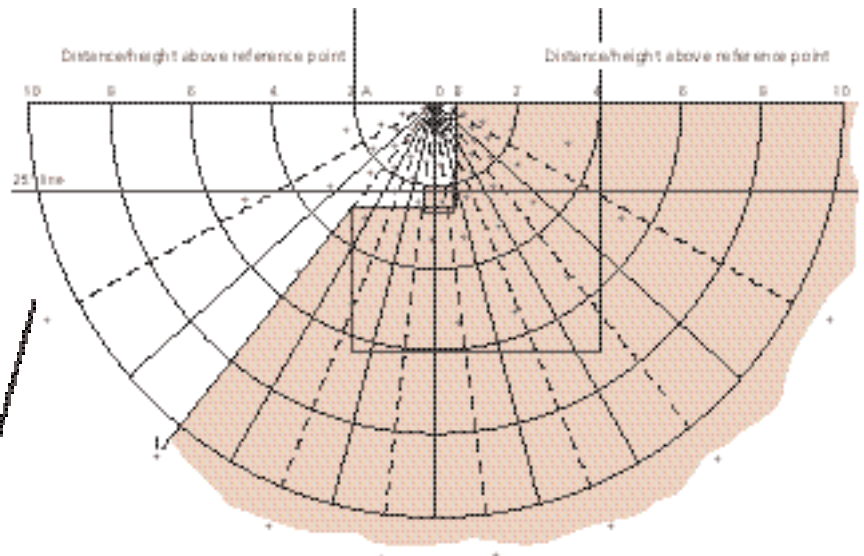

Figure 2.22 Special site plan of courtyard layout laid over skylight indicator (reduced to fit page)

2.1.4.2 *Impact on nearby buildings*

In designing a new development, the safeguarding of daylight to nearby buildings is very important. If any part of a new building — measured in a vertical section perpendicular to a main window wall of an existing building, from the centre of the lowest window — subtends an angle of more than 25° to the horizontal, the daylighting of the existing building may be adversely affected (see Figure 2.23). The loss of light can be quantified by calculating the vertical sky component at the centre of each main window of the existing building, with and without the new building in place. To check the impact on daylight distribution in the existing building, plot the no-sky line before and after. The *BS 8206* sunlight criterion can be used to check loss of sunlight. BRE Report BR209⁽²⁾ gives guidance.

The windows of some existing buildings will also have ‘Rights to Light’. The right to light is a legal right which existing windows may have over adjoining land. This will usually be the case if the existing building is more than 20 years old. The owner of the obstructed building may sue for removal of the obstruction or damages if a new building obstructs the light to these windows to below a minimum level; the designer of a new building should check that this does not happen. Movement of the no-sky line in an existing room is a warning sign, particularly if the no-sky line will cut off more than one-third of the room. BRE Report BR209⁽²⁾ explains how to calculate the loss of light, and Anstey⁽¹²⁾ and Ellis⁽¹³⁾ explain the legal aspects.

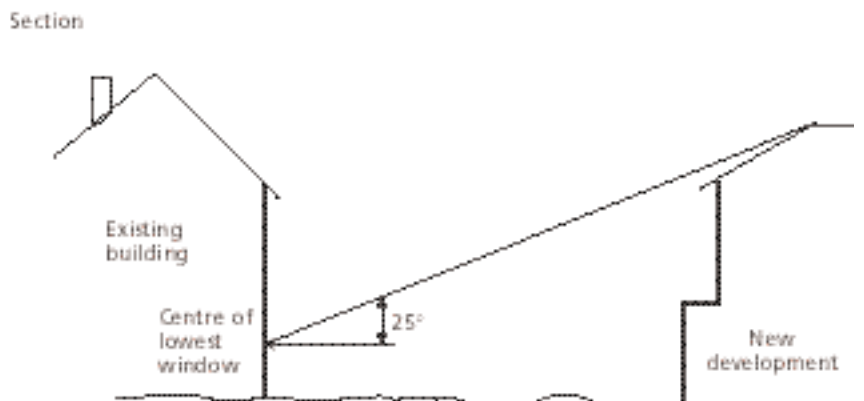
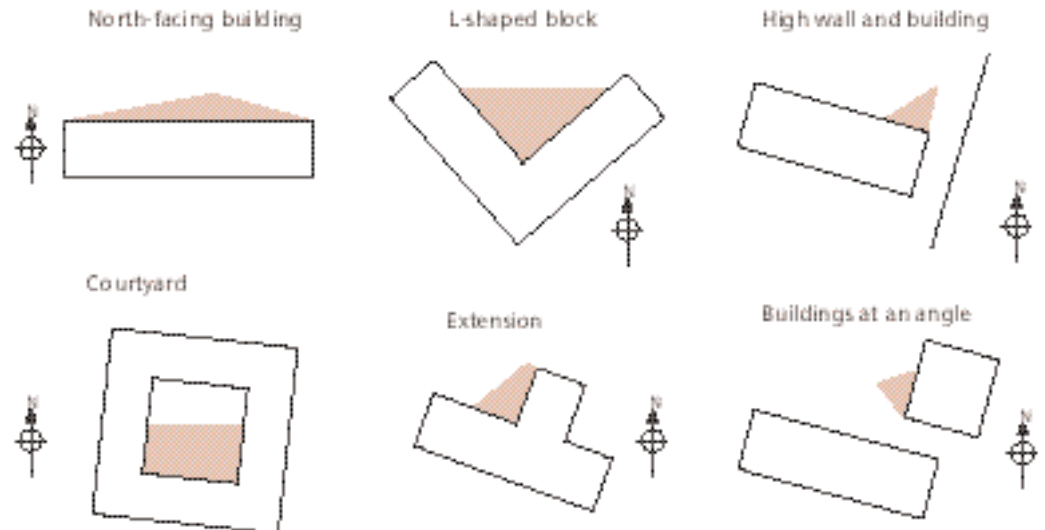

Figure 2.23 Measuring the impact that a new building has on the daylighting in an existing building

Figure 2.24 Examples of building layouts where poor sunlighting on the ground can occur. The shaded areas will receive no sunlight at the equinoxes



2.1.4.3 *Impact on open spaces*

Buildings also affect the sunlight in areas of open space surrounding the site, and there are special problems with certain types of layout (see Figure 2.24). In the northern hemisphere, the sunlit nature of a site can be retained by siting low rise, low density development to the south with taller, higher density development to the north. Courtyards can often turn out to be sunless and unappealing (see Figure 2.25) and special care is required in their design: wherever possible, courtyards should open out to the southern half of the sky. Moreover, specific parts of a site can be planned with sunlight in mind. This could include reserving the sunniest parts for gardens and sitting out, while using the shadier areas for car parking (see Figure 2.26); in summer, shade is often valued in car parks.

2.1.5 **Internal layout of building**

Site rooms according to their requirements for skylight, sunlight and solar gain. In houses, the solar gain will be used most effectively if living rooms are sited on the south side, with kitchens, bathrooms and garages to the north (see Figure 2.27). In non-domestic buildings, toilets and storerooms can be located in poorly daylit areas, while computer rooms, canteens and other rooms with high internal gains can be located to the north.

If an atrium or internal courtyard is planned, its dimensions should be chosen with care⁽¹⁴⁾. In a tall, narrow atrium, the base receives less light

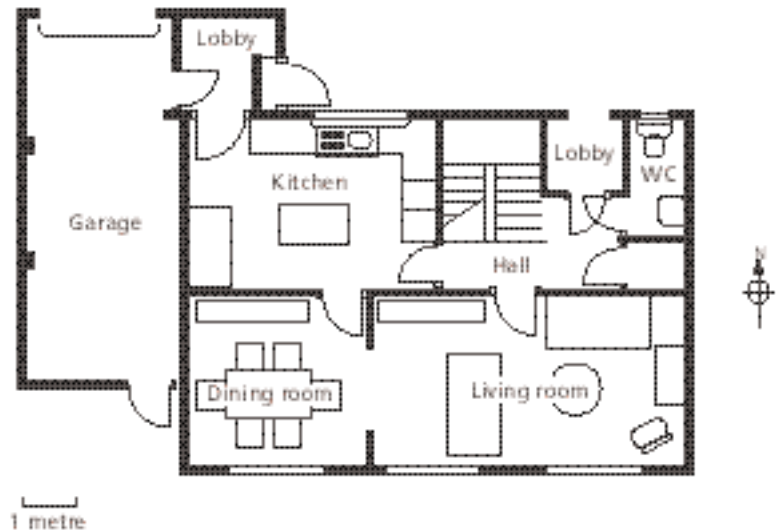

Figure 2.25 Rooms looking out from the internal corners of courtyards can often be gloomy and lack privacy



Figure 2.26 Shady areas near buildings are valued for car parking

Figure 2.27 The ground floor plan of a low-energy house. Living rooms have large glazed areas and face south while service rooms face north



and little light penetrates the adjoining lower floors. If the atrium is wide compared to its height, adjoining spaces have a better chance of receiving light through it. The depth to which daylight penetrates an adjoining space can be roughly estimated using the no-sky line. Figure 2.28 shows typical no-sky lines in an atrium building.

2.2 Window and rooflight size, shape and position

This section considers the size and shape of windows for sidelit rooms and the contribution that rooflights can make. Methods of predicting daylight and criteria against which to judge the values are suggested. Guidance is given on the visual considerations of view and glare and those of solar gain and ventilation. The section gives guidance which could be useful at several stages in the design process, from sketch design to final stages; several techniques are applicable at more than one stage.

2.2.1 Daylight requirements

A well daylit space needs both adequate lighting levels and light that is well distributed. In some rooms, the lighting level at the back falls dramatically below the level close to a window, to such an extent that occupants feel deprived even though their actual task illuminance is otherwise acceptable.

There are two possible reasons for discrepancy in lighting levels. The first is that the windows are heavily obstructed. The no-sky line (see section 2.1.2) offers a simple check here. If the no-sky line intersects a substantial area at working plane height, those working behind the no-sky line are likely to feel relatively deprived. This criterion applies both to rooflights and to side windows. Secondly, even where windows have an unimpeded view, there remains a limit to the acceptable depth of a sidelit room. Equation 2.1 (see section 2.1.2) can be used to check this. If the room is too

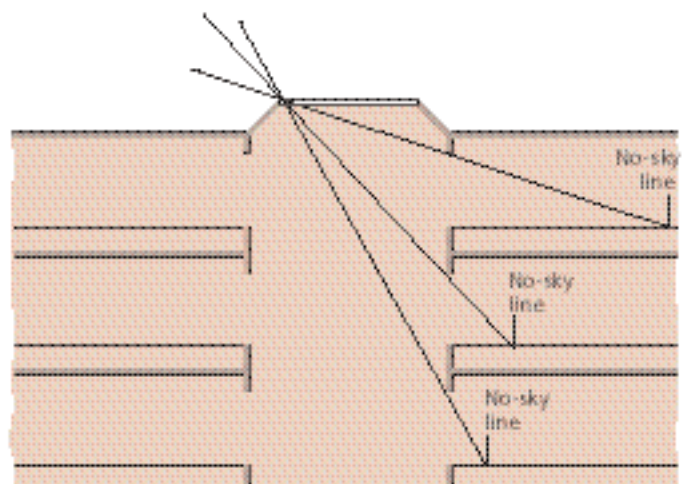

Figure 2.28 The no-sky lines in an atrium building. On the lower floors, only a tiny area may have a direct view of the sky

deep, the back of the room will look gloomy compared with the more brightly lit front half.

If distribution of light in the room is poor, electric lighting is likely to be switched on whenever the space is occupied. Features such as light shelves, prismatic glazing, and higher reflectances on the ceiling and at the rear of the room will provide some redistribution of daylight to the back of the room⁽¹⁵⁾. However the geometries of external obstructions, window head height and room depth may have an overriding effect. Increasing the average daylight factor on its own will not help; the contrast between the different areas of the room will still be too great. Window design should then be for view, for visual release, and for purposes other than stand-alone daylighting.

Poor daylight distribution can also occur in rooflit spaces if there are internal obstructions or the rooflights are too far apart. Section 2.2.3 explains how to adjust rooflight spacing to overcome this problem.

2.2.2 Window size

The next stage in the detailed window design procedure is to determine the required window area for a typical or critical room in the building. The final window area and choice of glazing must resolve the conflicting claims of daylighting, thermal insulation and solar protection.

2.2.2.1 Average daylight factor

To start the window sizing process, find the area of glazing required for a given daylit appearance of the space. The average daylight factor is a measure of the amount of skylight in a room. If the room is not too deep or obstructed (see section 2.1.2), an average daylight factor of 5% or more will ensure that an interior looks substantially daylit, except early in the morning, late in the afternoon or on exceptionally dull days. An average daylight factor below 2% generally makes a room look dull; electric lighting is likely to be in frequent use⁽¹⁰⁾. In domestic interiors, however, 2% will still give a feeling of daylight, though some tasks may require electric light. The *BS 8206* code of practice⁽¹⁰⁾ recommends average daylight factors of at least 1% in bedrooms, 1.5% in living rooms and 2% in kitchens, even if a predominantly daylit appearance is not required.

The average daylight factor (df) is proportional to window size. It is given by the expression

$$df = TA_w \theta M / \{A(1-R^2)\} \quad (2.2)$$

where the variables used are defined below.

Note that window bars may considerably reduce the effective area of glazing (see section 2.3.9). The average daylight factor equation may be inverted to show the glazing area A_w needed to ensure a chosen average daylight factor

$$A_w = dfA(1-R^2)/(T\theta M) \quad (2.3)$$

Equation 2.3 shows that the principal determinants of window area are:

- θ , the vertical angle subtended by visible sky is largely determined by the siting of the building and its relation with its neighbours (see section 2.1.4).
- df , the chosen average daylight factor governs the general character of the daylit space.
- T , the diffuse transmittance of the glazing material. For a given daylight factor, the required area of glazing A_w is inversely proportional to T . Tints and films such as those used for solar control have a surprising effect on daylight transmittance and their use should be avoided for daylighting design (see also section 2.3.2). Table 2.4⁽¹⁵⁾ gives approximate values for T ; for the innovative daylighting systems quoted these are indicative only and the actual transmittance will depend strongly on system geometry. Transmittances for different glass types are given in appendix A1.1. Where a room has two glazing types, for example prismatic glazing over a clear view window, TA_w in the formula should be replaced

Table 2.4 Approximate diffuse transmittances for various glazing types (clean)¹⁵

Type of glazing	Diffuse transmittance
Clear single glazing	0.8
Clear double glazing	0.7
Low emissivity double glazing	0.69
Double glazing and internal light shelf	0.55
Double glazing, internal and external light shelves	0.4
Double glazing with coated prismatic glazing	0.3
Double glazing with prismatic film	0.55
Double glazing with solar control mirrored louvres	0.3

by $T_1A_{w1} + T_2A_{w2}$ where T_1 and T_2 are the transmittances and A_{w1} and A_{w2} the areas of the different glazing types.

- R , the area-weighted average reflectance. High reflectances give a double benefit: they raise the average daylight factor and improve the distribution of daylight. At an early design stage assume, in rooms with white or off-white ceilings:

$R = 0.6$ for light walls and floor cavity

$R = 0.5$ for medium walls and floor cavity

$R = 0.4$ for dark walls and floor cavity

Appendix A1.3 gives detailed reflectance data for a range of building materials.

- A , the total area of interior surfaces (ceiling + floor + walls, including windows)
- M , the maintenance factor (see section 2.2.7 and Appendix A1.2). Note that this depends on designed provision for cleaning.

2.2.2.2 Thermal impact of windows

Window area also has important thermal consequences. Large windows will give much daylight but can also cause overheating. Cooling loads and internal temperature rise for naturally ventilated buildings can be determined by the procedures given in the *CIBSE Guide A: Environmental design*⁽¹⁶⁾, or other recognised methods such as given in the fenestration section of the *ASHRAE Handbook of fundamentals*⁽¹⁷⁾. Computer software is also available. Tables 2.5 and 2.6 give a broad indication of the influence of glazing for a 100 m³ space per m² of glazing in June. For smaller or larger spaces the temperature rises are approximately inversely proportional to the volume (thus for 50 m³ multiply by 2) for the same ventilation rate. Figures 2.29-2.31 present the temperature rise data graphically.

Solar loads and internal temperatures are greatly influenced by the inertial effects of the building, which depend on the thermal capacity of building materials, as well as the type of window, its glazing and size. In buildings using heavy masonry materials, thermal inertial effects can delay the response to solar gain for several hours and this can be an important aspect of design, especially where mechanical cooling is not envisaged. Tables 2.5 and 2.6 give a broad indication of the effect for various building weights in delaying the peak temperature rise or solar load.

If solar overheating is likely to be a problem, there are three possibilities: reduce window area, use tinted 'solar control' glazing or use other forms of shading device. Tinted glazing, however, generally reduces the daylight factor more than it reduces the solar gain (the main exceptions to this are specialised low emissivity 'heat mirror' glazings, see section 2.3.2). For this reason it is better to rely on smaller windows and/or external blinds, sunbreaks etc. than on special forms of glazing to mitigate summertime overheating. Solar protection can be devised to block direct radiation to eliminate excessive solar gain while providing high diffuse transmission (see section 2.3.4).

Table 2.5 Maximum temperature rise in K during the daytime in June for a 100 m³ space per m² glazing with three air changes per hour

Glass combination	Shading coefficients		Orientation				
	SW	LW	East	SE	South	SW	West
Light masonry materials			0745 h	0930 h	1200 h	1430 h	1615 h
Ord DG	0.70	0.12	1.82	1.72	1.49	1.72	1.82
Ord DG + blind	0.08	0.46	1.24	1.17	1.01	1.17	1.24
Glass/blind/glass	0.08	0.21	0.67	0.63	0.55	0.63	0.67
AS DG	0.41	0.16	1.28	1.21	1.04	1.21	1.28
SC DG	0.06	0.12	0.43	0.41	0.35	0.41	0.43
Medium masonry materials			0845 h	1030 h	1300 h	1530 h	1715 h
Ord DG	0.70	0.12	1.57	1.5	1.29	1.5	1.57
Ord DG + blind	0.08	0.46	1.11	1.06	0.91	1.06	1.11
Glass/blind/glass	0.08	0.21	0.6	0.57	0.49	0.57	0.6
AS DG	0.41	0.16	1.11	1.06	0.91	1.06	1.11
SC DG	0.06	0.12	0.39	0.37	0.32	0.37	0.39
Heavy masonry materials			0930 h	1130 h	1400 h	1630 h	1815 h
Ord DG	0.70	0.12	1.42	1.36	1.17	1.36	1.42
Ord DG + blind	0.08	0.46	1.03	0.99	0.85	0.99	1.03
Glass/blind/glass	0.08	0.21	0.55	0.53	0.45	0.53	0.55
AS DG	0.41	0.16	1.01	0.97	0.83	0.97	1.01
SC DG	0.06	0.12	0.36	0.34	0.3	0.34	0.36

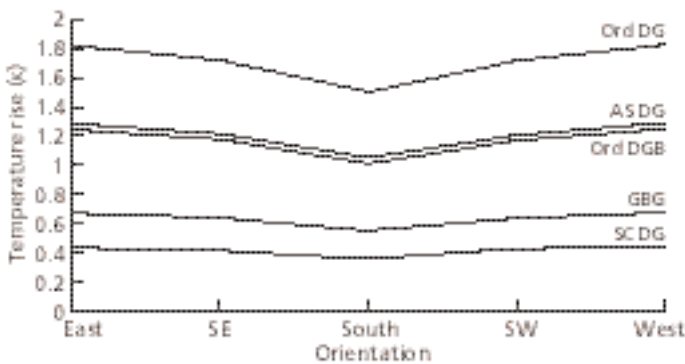
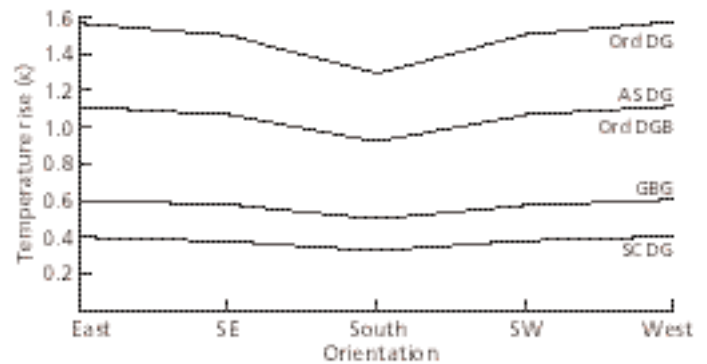
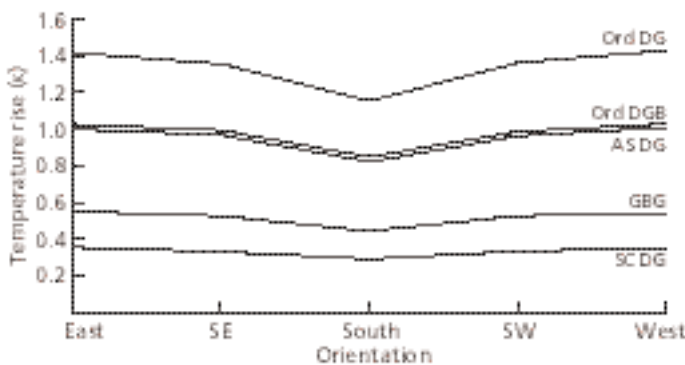
**Figure 2.29** Light masonry materials: temperature rise in June per m² glazing for a space of 100 m³ with three air changes per hour**Figure 2.30** Medium masonry materials: temperature rise in June per m² glazing for a space of 100 m³ with three air changes per hour**Figure 2.31** Heavy masonry materials: temperature rise in June per m² glazing for a space of 100 m³ with three air changes per hour**Key for Tables 2.5 and 2.6 and Figures 2.29-2.31**

Ord DG	Clear double glazing (6 mm/12 mm air space/6 mm)
Ord DG + blind (DGB)	Ditto with internal venetian blind*
Glass/blind/glass (GBG)	Ditto with enclosed venetian blind*
AS DG	Double glazing with outer 6 mm body-tinted bronze absorbing glass
SC DG	Double glazing with outer 6 mm glass with a bronze reflective coating

* Venetian blind is set at 45°, a spacing ratio 1:2, louvre reflectance 0.7

Table 2.6 Maximum solar loads in kW during the daytime in June for a 100 m³ space per m² of glazing with three air changes per hour

Glass combination	Shading coefficients		Orientation				
	SW	LW	East	SE	South	SW	West
Light masonry materials			0745 h	0930 h	1200 h	1430 h	1615 h
Ord DG	0.70	0.12	0.42	0.39	0.34	0.39	0.42
Ord DG + blind	0.08	0.46	0.29	0.27	0.24	0.27	0.29
Glass/blind/glass	0.08	0.21	0.16	0.14	0.13	0.14	0.16
AS DG	0.41	0.16	0.3	0.27	0.24	0.27	0.3
SC DG	0.06	0.12	0.1	0.09	0.08	0.09	0.1
Medium masonry materials			0845 h	1030 h	1300 h	1530 h	1715 h
Ord DG	0.70	0.12	0.38	0.35	0.31	0.35	0.38
Ord DG + blind	0.08	0.46	0.29	0.27	0.23	0.27	0.29
Glass/blind/glass	0.08	0.21	0.15	0.14	0.12	0.14	0.15
AS DG	0.41	0.16	0.27	0.25	0.22	0.25	0.27
SC DG	0.06	0.12	0.1	0.09	0.08	0.09	0.1
Heavy masonry materials			0945 h	1130 h	1400 h	1630 h	1815 h
Ord DG	0.70	0.12	0.34	0.31	0.27	0.31	0.34
Ord DG + blind	0.08	0.46	0.29	0.26	0.23	0.26	0.29
Glass/blind/glass	0.08	0.21	0.15	0.14	0.12	0.14	0.15
AS DG	0.41	0.16	0.25	0.23	0.2	0.23	0.25
SC DG	0.06	0.12	0.09	0.09	0.07	0.09	0.09

The BRE *Environmental design guide*⁽¹⁸⁾ is helpful in balancing the conflicting requirements of solar gain and daylight. It is intended for naturally ventilated and daylit offices, and can be used by designers (architects and building services engineers) to evaluate the consequences of alternative design solutions on summer thermal and winter visual comfort. The focus of attention, however, is on windows, and the guide allows designers to decide the window size and type for an acceptable comfort range in an office room or to assess a design, with a given window size and type, for its thermal comfort performance. The strongest point of the *Environmental design guide* is its integration of the three most important processes that affect summertime overheating in buildings, namely, thermal gain/loss/storage, ventilation and daylighting. The paper-based version involves no calculations as it uses visual and tabular aids to guide the user to arrive at a solution. The software version⁽¹⁹⁾ is more flexible and allows more cases to be studied by varying the input parameters.

There is a similar conflict between the requirements for daylighting (larger windows and high transmittance) and those of thermal insulation (smaller windows with lower thermal transmittance). Heat loss through the window is characterised by the U-value. Section 3.6 in the *CIBSE Guide* Section A3⁽²⁰⁾ covers the combination of the different components of the window that affect its overall U-value — glazing materials, frame and sash, bridging effects and the combination of the window with various types and positions of blinds and curtains.

Calculation of the overall heat loss is by summing the area U-value product for each building element and the design temperature difference between the designated internal design temperature and the external temperature. Appropriate design data for internal dry resultant temperatures and external temperatures are provided in the *CIBSE Guide* Section A1⁽²¹⁾ and Section A2⁽²²⁾, respectively.

In most countries, there is substantial legislation requiring minimum U-values to be met to save energy, and the UK is no exception. In England and Wales, The Building Regulations Part L: Conservation of Fuel and

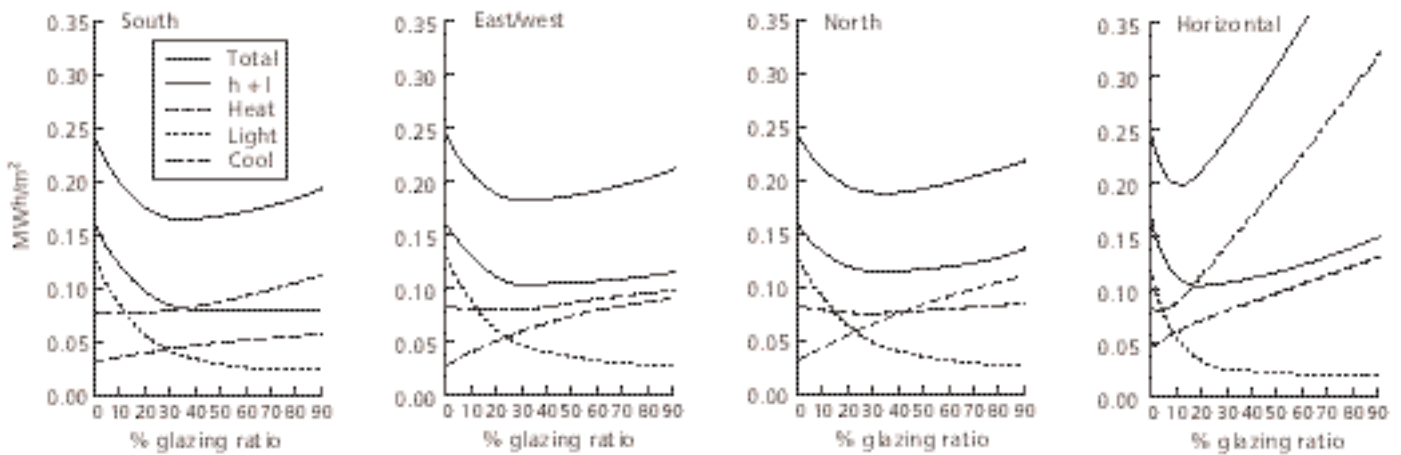

Figure 2.32 Graphs using the LT method for predicting energy consumption per square metre of floor area

Power include important prescriptions to U-value and overall energy use. The 1995 version of Part L sets standards of energy efficiency for all new building types by a prescriptive approach based on maximum U-values for opaque fabric building elements and by limiting glazed areas according to the type of glazing used and the type of building involved. An energy-use calculation procedure allows additional flexibility and provides for recognition of useful solar gains. In Scotland Part J gives equivalent guidance, while in Northern Ireland Part F is the relevant document.

Multiple glazing is particularly effective in reducing the U-value but penalises the light transmission; every extra sheet of clear glass reduces the transmittance by 15-20% (see section 2.3.2 and appendix A1.1). Reductions in glass transmittance not only reduce light transmitted into the room but may also affect the qualities of view. The multiple reflections on glass surfaces in multi-glazed windows could distract observers.

Please replace
with new slide.

Make image 117 mm deep,
and adjust width of pic box
(on left side) up to a
maximum of 94 mm so
includes all of image. (If
need to crop from width,
crop both sides equally).

Pic box runaround is set so
caption will stay 12 pt from
left edge

Figure 2.33 Daylit gallery at the Burrell Collection

Table 2.7 Energy balance value (W/m²K)

North	East/West	South
1.84	1.06	0.19

The U-value does not include the contribution of winter solar gain, which can be significant. The energy balance value⁽²³⁾ shows explicitly how the direct comparison, often made in energy-use studies, between U-values of glazing and opaque envelope components does not give the overall energy impact of each component. Table 2.7 shows the energy balance values for ordinary double glazing (U=2.9 W/m²K) at a location in south-east England.

Ventilation heat loss is important too. The topic is covered by *CIBSE Guide* Section A4⁽²⁴⁾. The overall ventilation loss is given by:

$$L_v = V \times N \times (t_i - t_e) \quad (2.4)$$

where V is total volume (m³), N is number of air changes per hour, and t_i and t_e appropriate internal and external temperatures.

In tight buildings with well sealed windows, N will be less than 0.5, rising to 2 for leaky windows and typically up to 10 when windows are opened and there is the possibility of cross-ventilation. With well insulated buildings, ventilation becomes the most significant part of heat loss and building services are usually designed to recover as much ventilation loss as possible.

The LT Method⁽²⁵⁾ is an energy design tool developed expressly to allow designers to understand the energy implications of early design decisions. It uses a mathematical model to predict annual primary energy consumption per square metre of floor area as a function of local climatic conditions, orientation of façade, area and type of glazing, obstructions due to adjacent buildings and the inclusion of an atrium (optional). The LT method includes allowances for heat loss, cooling loads due to solar gain and lighting energy saved by daylight (see Figure 2.32). It allows the comparison of alternative designs on the basis of parameters known at a reasonably early stage of design, but it involves some minor manipulations of data and should not be used for detailed design at a later stage.

2.2.3 Rooflights

Rooflights can be a useful supplement to side windows in an interior. The light can brighten the back of an excessively deep room or bring a welcome balance to strong sidelighting. Rooflights can be used alone to light particular types of interiors. While they will not provide a view of outside surroundings, the walls are freed for display purposes, to act as robust surfaces against the activities in the interior or to aid security against outside intrusion. Very deep interiors can be daylight only by using rooflights. Figure 2.33 shows an abundance of daylight from a glazed roof and light surface finishes. Sunlight adds to the effect.

Typical rooflight profiles are shown in Figure 2.34. Each type has advantages and disadvantages (see Table 2.8), and different types are suitable for use in different situations.

2.2.3.1 Rooflight spacing

If adjacent rooflights are too far apart the daylighting will look patchy. The uniformity of illuminance in a rooflit building depends on the spacing to height ratio — the ratio of spacing between adjacent rooflight centres to the height of rooflight centre above a horizontal reference plane (see Figure 2.35). Dewey and Littlefair⁽²⁶⁾ have calculated how, under overcast conditions, the uniformity of illuminance beneath some typical rooflights falls off as the spacing increases (see Figure 2.36).

There is no need for absolutely uniform rooflighting to be achieved: while meaningless patches of light and pools of darkness are irritating, a pattern of light and shade tuned to the rhythm of the architecture can be attractive.

For task lighting, the ratio of minimum to average illuminance over a specific task and its immediate surround should not be less than 0.8, but this ratio may legitimately fall to 0.2 or less over areas of the workspace remote from the workstation⁽²⁷⁾.

Figure 2.34 Rooflight profiles

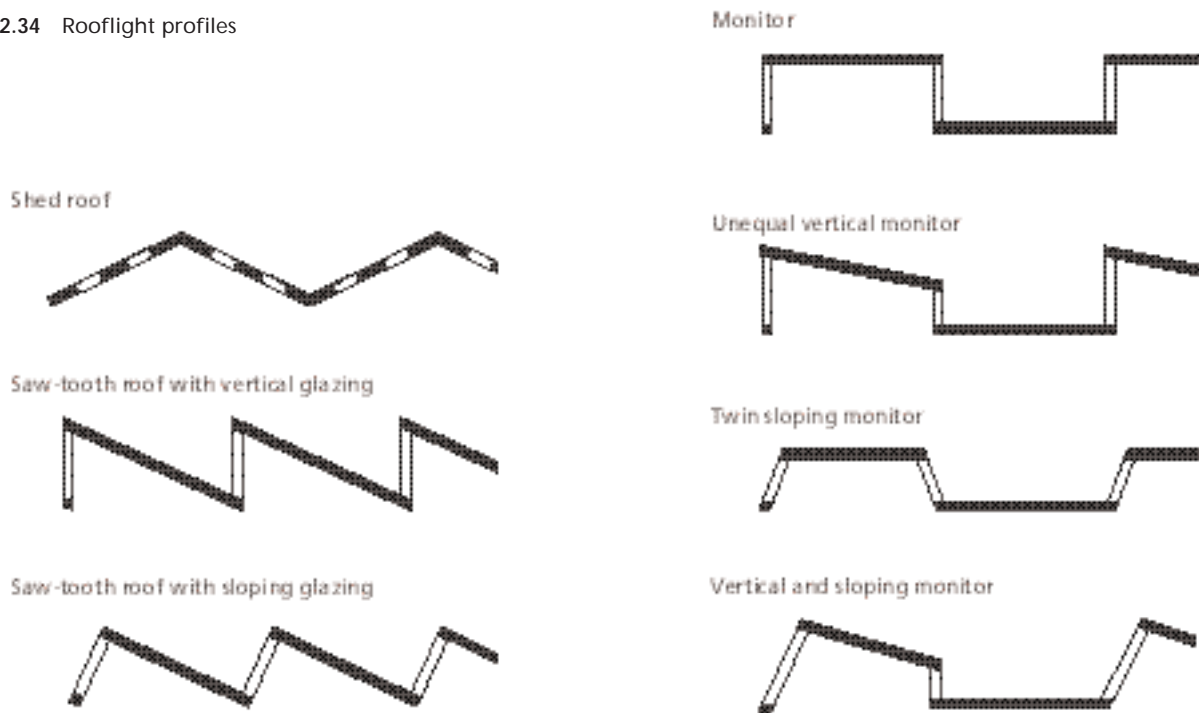
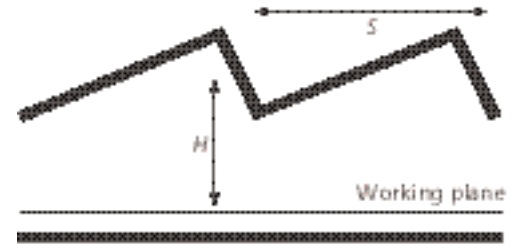

Table 2.8 Comparison of rooflights

Type of rooflight	Advantages	Disadvantages
Horizontal rooflights, small translucent domes, pyramids and lantern lights	<p>Useful supplement to side windows</p> <p>Less glass needed for a given daylight factor, thanks to large angle θ in equation 2.2 (see section 2.2.2)</p> <p>An internal skirt can effectively reduce glare (but at the expense of uniform daylighting)</p> <p>Can be fitted with an upstand for controlled ventilation</p> <p>Can be concealed from external passers-by</p>	<p>Seldom suitable for daylighting a whole interior</p> <p>Difficult to protect from solar gain</p> <p>Directs relatively little light onto vertical surfaces, making the interior look darker</p> <p>Condensation will not run down the face of a near-horizontal sheet, so may drip on occupants below</p> <p>Dirt collects more readily on horizontal surfaces</p> <p>Easy to fall through when cleaning</p> <p>Rooflights in flat roofs may tempt burglars</p> <p>Security must be addressed</p>
'Shed' rooflights	<p>Often the least expensive profile</p> <p>Suitable for interiors such as warehouses where solar gain would be a minor problem</p> <p>Less glass needed for a given daylight factor, comparable with horizontal rooflights above</p>	<p>Difficult to protect from solar gain</p> <p>Dirt collects more readily on near-horizontal surfaces</p> <p>Indoor surfaces may be hard to reach for cleaning</p>
Sawtooth rooflight*	<p>Facing north in the northern hemisphere, is usually the best choice where solar gain would otherwise be troublesome</p> <p>Better control of solar gain and solar glare</p>	<p>Direct daylighting is unidirectional; tall machinery or storage racks can cast heavy shadows</p> <p>Orientation is fairly critical</p> <p>Large enclosed volume can lead to thermal stratification</p>
Monitor rooflights	<p>Flat ceilings can accommodate overhead services, including electric lighting, without seriously obstructing incoming daylight</p> <p>Controlled access to sunlight, especially with asymmetrical monitors</p> <p>Easy access from the roof for cleaning the outside of the glazing</p>	<p>Low daylight factors: if monitors are closely spaced, the angle θ in equation 2.2 (see section 2.2.2) is reduced. If monitors are widely spaced the glass/floor area ratio is reduced. In either case, the daylight factor suffers</p> <p>Flat horizontal ceilings receive no direct skylight and may therefore look dull</p>

*Vertical sawtooth glazing provides better protection than a sloping sawtooth, but the smaller angle θ in equation 2.2 (see section 2.2.2) penalises the average daylight factor

Figure 2.35 The ratio of S (the spacing between adjacent rooflights) and H (height of rooflight centre above a horizontal reference plane) determines the uniformity of illuminance



2.2.4 Atria

Windows facing an atrium (see also section 2.1.3) should generally have clear transparent glazing to take full advantage of the view and available daylight.

The daylighting of successive storeys of rooms adjoining an atrium is interdependent and requires a balanced approach⁽¹⁴⁾. Light from the sky can easily penetrate the upper storeys but not the lower, which rely primarily on light reflected from internal surfaces of the atrium (see Figure 2.37). The upper storeys need less window area than the lower ones, and if the atrium walls are light in colour the upper walls will reflect light toward the lower storeys. A further strategy is to use clerestory windows to allow light from the overhead rooflighting to penetrate the rooms, side windows to allow a view and, on lower storeys, light reflected from the atrium floor.

Designers must make safe provision for cleaning the atrium glazing internally and externally. This may usefully be combined with access to the electric lighting equipment.

2.2.4.1 Average daylight factor in rooms off an atrium

Daylight in a room which receives its light from another internal space, such as an atrium, can be estimated by a two stage process. The example given here is for an atrium, but the method can be used for other spaces which rely on borrowed light. The first step is to assess the average daylight factor df_a in the atrium itself. Equation 2.2 (see section 2.2.2) gives the average daylight factor on a horizontal working plane; where the average daylight factor on all the surfaces in a space is required, the following formula⁽¹¹⁾ can be used:

$$df_a = \frac{TA_{wa}\theta}{2A(1-R)} \tag{2.5}$$

where A_{wa} is the area of atrium glazing, T its transmittance and θ the angle of visible sky viewed from the glazing, A is the total area of the atrium surfaces and R their average reflectance.

The contribution from the atrium to the average daylight factor in the adjoining space (df_{sav}) is given by equation 2.6⁽¹¹⁾, which is based on

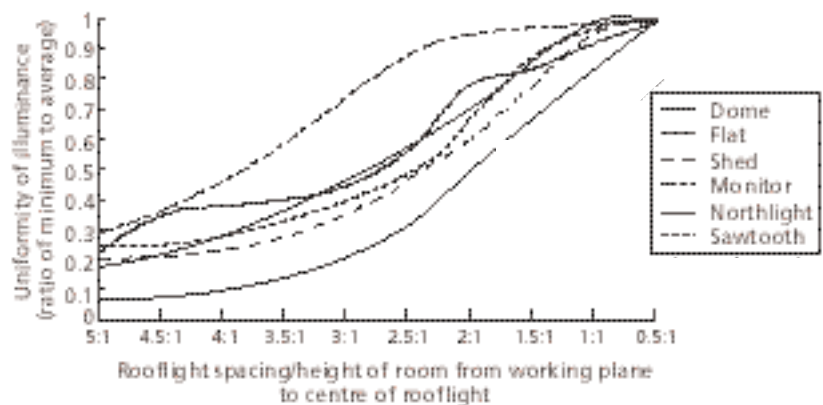
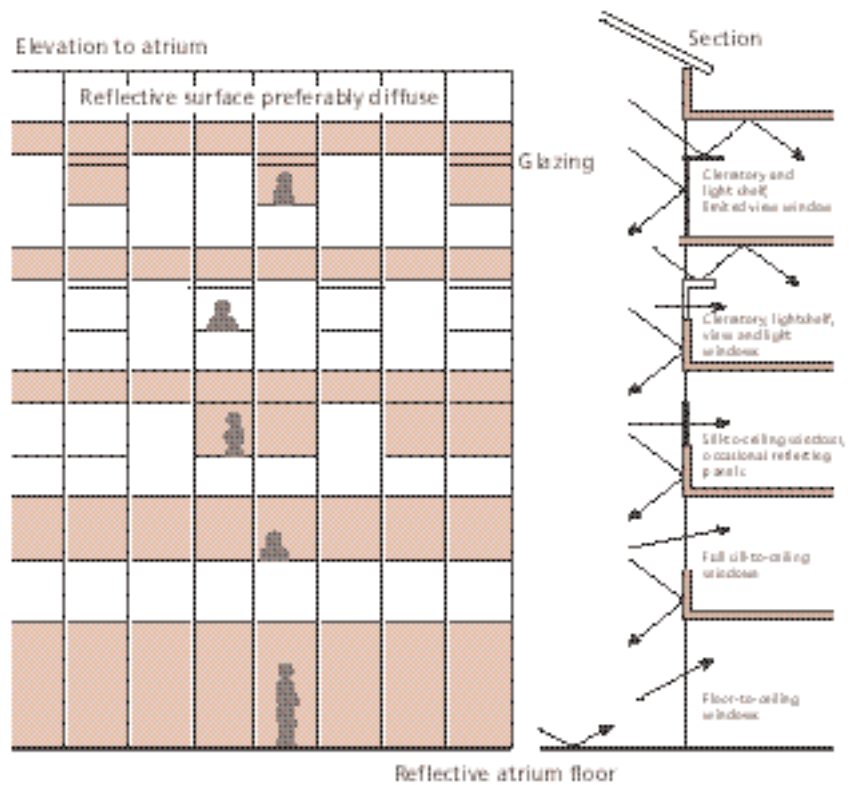

Figure 2.36 Uniformity of illuminance decreases as the spacing between rooflights increases

Figure 2.37 Penetration of daylight in a building with atrium



equation 2.2 (see section 2.2.2) except that the angle of visible sky θ is replaced by twice the daylight factor on the outer face of the window:

$$df_{sav} = \frac{2A_w T_s df_a}{A_s (1 - R_s^2)} \quad (2.6)$$

where A_w is the net area (m^2) of the glazing between the space and the atrium; T_s is the diffuse visible transmittance of this glazing (for no glazing, just an open aperture, 1.0 is used); A_s is the total area (m^2) of the room surfaces (ceiling, floor, walls and windows, including those to the atrium); and R_s is the average reflectance of the room.

Often an adjoining room will also be lit from the outside of the building. The average daylight factors from each set of glazing can simply be added together.

2.2.5 Window shape and position

Once the window area has been fixed, perhaps as indicated in section 2.2.2, the principal visual determinants of window shape and position are:

- view
- visual comfort
- distribution of daylight.

2.2.5.1 View

A view may be of several types, for example to a pleasant scene outside or a glimpse of a small part of another space outside or inside. The activity in the room is relevant: are the occupants sitting at fixed positions all day or just passing through? It is found generally that people prefer almost any view out to no view out. While access to a view is desired, the need for privacy often requires that the view is restricted. Spaces will have a hierarchy of view and privacy, which the designer must determine.

In principle, one can predict the outdoor view from any point indoors. In practice people move around, so analysis should concentrate on occupants remote from a window. The simplest method is to draw a straight line from the chosen point to an object outside. If the line passes through a window, in both plan and cross-section, the object will be visible; if not it will be hidden. A more elegant technique is illustrated in Figure 2.38;

here an interior perspective of the window is superimposed on a correctly scaled photograph or perspective of the scene beyond.

Outdoor scenes are typically stratified. The sky forms a top layer. The foreground, mainly horizontal, is the lowest layer. The middle layer, not always present, includes trees and buildings. The foreground is where people's gaze is often drawn. It contains movement — the coming and going of people, vehicles etc — and provides visual cues about the distance, and hence the scale, of objects in the middle layer.

Visual information is typically concentrated in the junctions between the layers: along the skyline, and where verticals meet the ground. This suggests that a satisfying view would embrace both skyline and foreground (see Figure 2.38). A tiny window would thus take the form of a vertical strip. A large window, on the other hand, would extend horizontally rather than vertically. But each prospect should be considered afresh. Windows are the eyes, the ears and the nostrils of a building. If there is an attractive view, the pattern of windows should respond accordingly.

2.2.5.2 Visual comfort

People prefer the visual environment to be balanced in terms of brightness: undue brightness (or glare) may cause discomfort or reduce the ability to discern detail. It is the relative, not the absolute, brightness that is important.

Windows may give rise to glare in various ways. The bright sky may be close to the line of view. It may give rise to reflections on display screens, books, meters or keyboards. Light from the sun may shine directly or by reflection to create glare.

For interiors with display screen equipment (see section 2.3.5), window locations need to be planned with care. Windows on adjacent walls give good daylighting distribution but make it difficult to avoid screen reflections and glare. For this reason, the corners of buildings need special

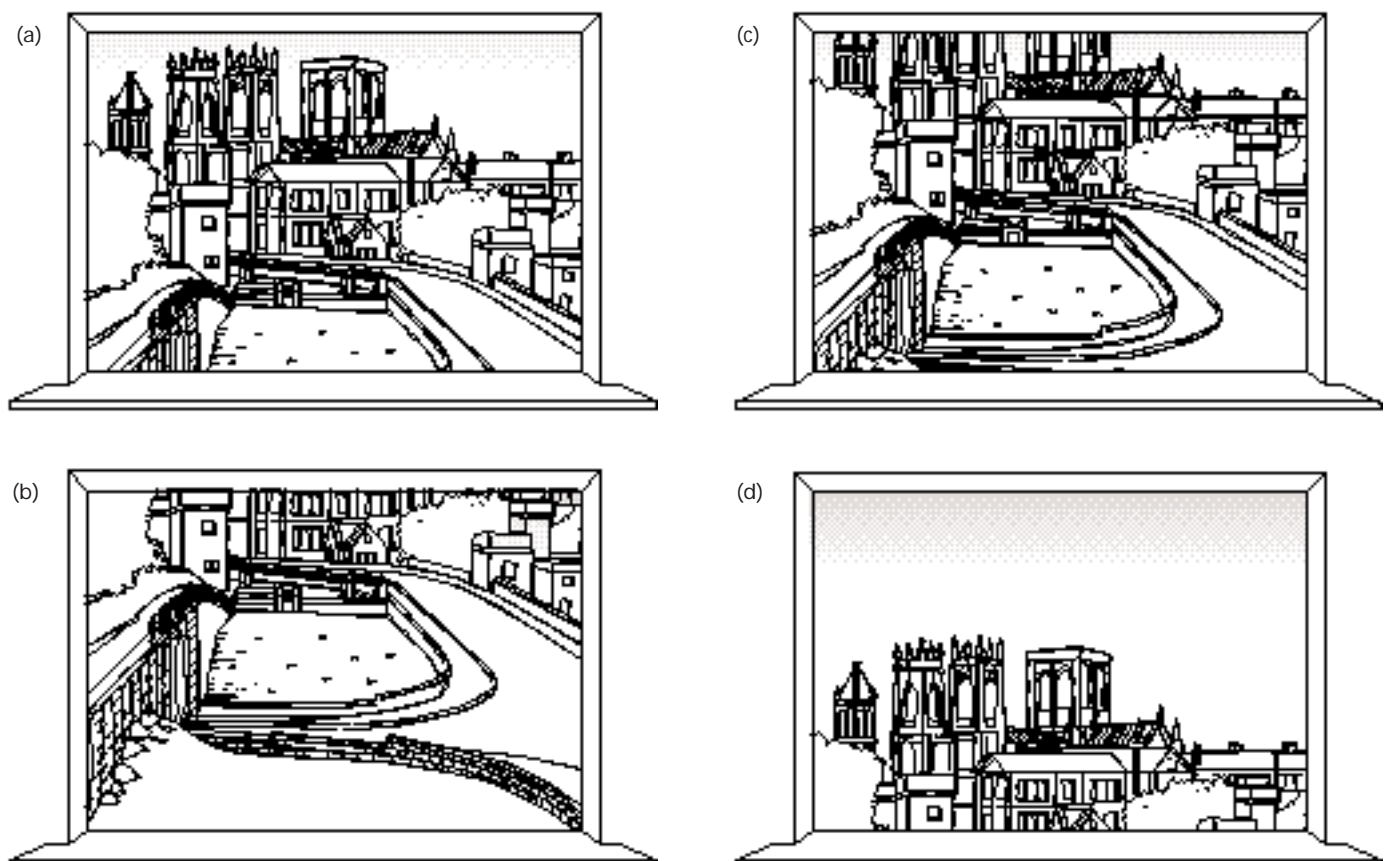

Figure 2.38 View through alternative windows from a given point indoors: (a) revealing the whole sky line, (b) no sky visible, (c) some sky visible and (d) no foreground visible

attention in design. Windows on opposite walls make it easier to align workstations to avoid glare problems.

Screen reflection and glare difficulties tend to be worse in wide, open plan spaces with continuous 'ribbon' glazing. Cellular offices seldom cause problems. If screens are in frequent use in wide, open plan areas the space should, wherever possible, be divided using furniture and low partitions into a succession of smaller spaces. Long runs of glazing should also be separated into a series of smaller windows.

2.2.5.3 *Sunlight glare*

Almost all complaints of glare from windows are attributable to direct sunlight. In domestic-scale situations, where occupants are free to move around and to draw the curtains, solar glare is of little consequence. Where occupants are confined to a desk, drawing board or computer screen, direct sunlight can be a major source of glare. It also causes overheating.

Often effective remedies for solar heat gain, such as external shading, also protect occupants against visual discomfort. The best strategy is therefore to address the thermal and visual problems together, on the lines indicated in section 2.3.4.

2.2.5.4 *Sky glare*

Glare from windows can arise from excessive contrast between the luminance of the visible sky and the luminance of the interior surfaces within the field of view. The window walls, the window reveals and the interior surfaces adjacent to rooflights should be of high reflectance (white or a light coloured). Walls generally should not be glossy. In addition, glare from the sky and bright external surfaces can be reduced by:

- (a) Providing additional lighting on the window wall from either other windows or electric lighting. The latter expedient is deprecated as wasteful.
- (b) Reducing the luminance of the sky as seen from the interior by the use of translucent blinds, curtains or tinted/solar glazing, if adequate illumination can still be provided.
- (c) Splaying the reveals of windows and rooflights to give a larger area of intermediate brightness between the exterior view and the window wall.

The aim should be to produce a subtle gradation of luminance from darker parts of the room to the visible sky.

2.2.5.5 *Daylight distribution*

The amount of direct skylight reaching a given point indoors depends mainly on how much sky can be seen from that position. Once the overall area of glazing has been fixed (see section 2.2.2), the placing and shaping of the windows for daylight access is simply a matter of ensuring that areas which require a high daylight factor 'see' as much sky as possible. In general, high window heads will, by geometry, allow deeper daylight penetration; additionally, when overcast skies prevail, high window heads will allow a brighter part of the sky to 'see' into the room. Figure 2.39 illustrates how different shapes and positions of windows produce different daylight distributions in rooms.

In the rare cases where a specific daylight factor is mandated at a certain critical point, one might consider using the techniques described in section 3.

2.2.5.6 *Window patterns*

It is clear from the above that there is a conflict between providing visual comfort, view and daylight access:

- visual comfort requires little or no visible sky; direct sunlight in the field of view is especially undesirable
- view favours an unhindered view of the skyline, but beyond this any additional skylight does little to enhance the view
- daylight requires access to plenty of open skylight.

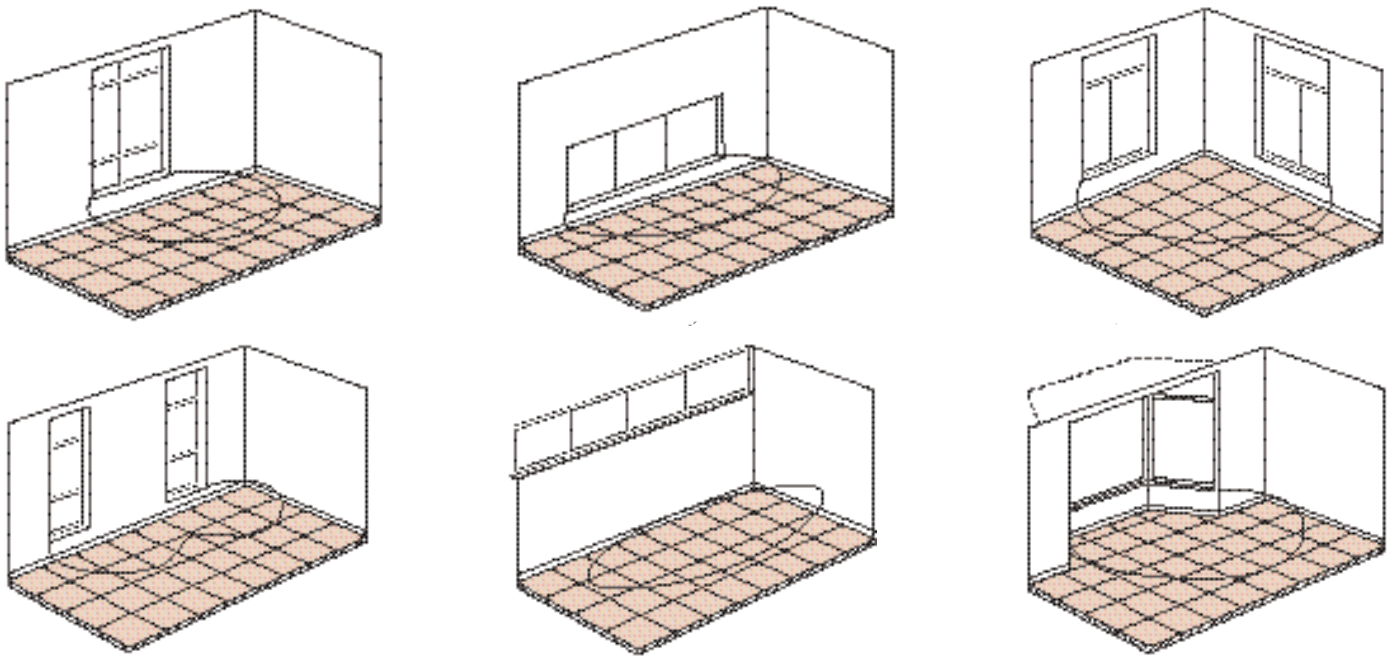

Figure 2.39 Daylight distributions produced by different window positions

These conflicting claims must be prioritised and resolved. Clearly their resolution, in terms of window shape and position, must be easier if the overall window area has first been determined, as in section 2.2.2.

2.2.5.7 *Windows in more than one wall*

Windows in more than one wall offer the following advantages:

- improve the uniformity of the daylighting, by displacing the no-sky line and by increasing the area of sky visible from deprived areas
- reduce glare substantially by increasing the luminance of the surfaces surrounding the window without increasing the luminance of the visible sky outside
- in naturally ventilated spaces, increase the ventilation rate on hot days, mitigating the effects of solar gain.

Where windows are on adjoining walls this can cause problems for users of display screen equipment (see sections 2.2.5.2 and 2.3.5).

2.2.6 Ventilation

2.2.6.1 *Ventilation, air movement and deep spaces*

In a naturally ventilated building, openable windows can remove excess heat on warm days to prevent overheating and also provide background ventilation for health and comfort on cool days. However, air movement is greater near open windows than in inner areas of the room, which can create problems. Occupants near openable windows will usually have control of the window opening and may, therefore, tend to open the window to suit only their own comfort local to the window. This problem can be minimised by good window design, which seeks to provide adequate year-round, draught-free ventilation for the benefit of all occupants^(5, 6).

Away from the open window, or in deep office spaces, comfort can be enhanced by increasing air movement using well-designed desk or ceiling fans. As a rule of thumb, an air speed of 2 m/s will produce a cooling effect for occupants equivalent to about 3°C reduction in air temperature. Fans should operate down to very low speeds to ensure their effectiveness over a wide range of conditions. It is a frequently quoted myth that fresh air does not penetrate deep into office spaces. Certainly the air entering a room warms as it passes through ('temperature pick-up') and its speed falls rapidly, giving a sense of losing its freshness in terms of thermal comfort. However, from the point of view of diluting contaminants (i.e.

air quality), research has shown that the amount of outside air arriving at any point varies very little throughout the room⁽²⁸⁻³⁰⁾.

Natural ventilation occurs through an open window because of net pressure differences between the interior and the exterior caused by wind flow around the building and buoyancy forces. Cross-ventilation occurs when inflow and outflow openings in external walls have a significant internal air flow path between them. Where an opening is in one wall only and isolated from other air flow routes to outside, much reduced 'single-sided ventilation' or 'two-way' air exchange occurs primarily due to the effects of wind turbulence and buoyancy locally over the opening.

The Building Regulations Part F: Ventilation (Part K in Scotland and Northern Ireland) set requirements for ventilation in all building types either via opening windows or mechanical ventilation systems.

2.2.6.2 Size

The amount of openable area provided for background ventilation should be estimated to provide year-round ventilation according to occupancy and for rapid ventilation to maintain thermal comfort even with maximum expected heat gains. In the UK, ventilation is usually wind-driven, even on so-called still days. The ventilation air flow through the openings should be estimated using, in simple cases, published guidance in *CIBSE Guide A: Environmental design*⁽¹⁶⁾ and *BS 5925 Code of practice for ventilation principles and designing for natural ventilation*⁽³¹⁾ or, in more complicated (multiroomed or multi-storey) cases, using specialist prediction tools such as the computer program BREEZE⁽³²⁾.

The size of opening has only a small impact on air movement (i.e. air speed). Specifically, for single-sided ventilation, air speeds are greater for larger openings only when wind is blowing obliquely towards the window. With cross ventilation, the air speed will increase with increasing size of the smaller opening; the maximum speeds (near the inlet) are greater where outlets are larger than inlets.

2.2.6.3 Shape

Ventilation is affected by the shape and orientation of the opening pane, which interacts with the local external airstream⁽³³⁾, and is greater if there are two openings in the same wall. In this case, ventilation is significantly increased if vertical projections protrude perpendicularly from the side of the two openings, with one downwind of the inlet (i.e. upwind opening) and another upwind of the outlet (see Figure 2.40). Side-opening window panes can act in the same way where these are hung on appropriate sides. Each design of individual window opening (e.g. sash, centre pivot, sliding and side hung) may have effects on air

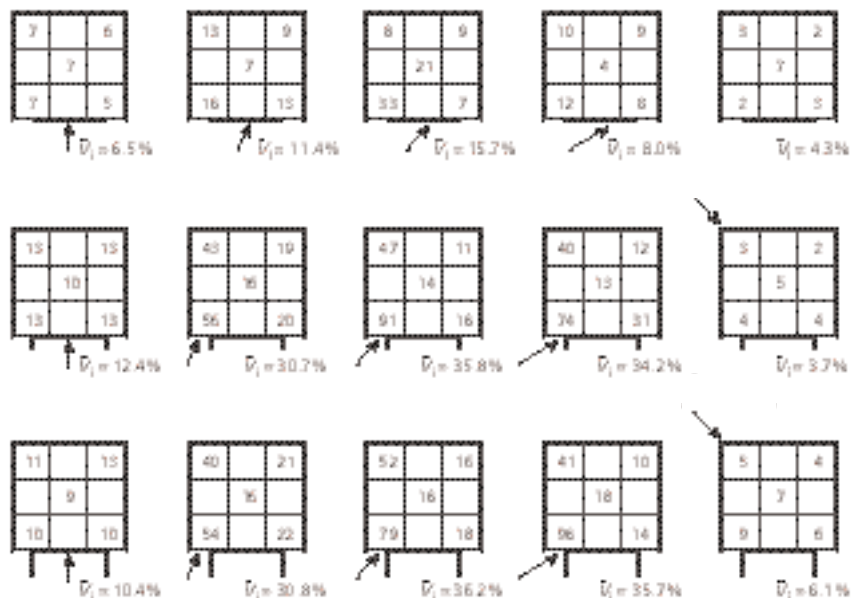

Figure 2.40 Floor plans showing average indoor air velocity speed (\bar{v}_i) as a percentage of the outdoor air velocity in five wind directions for window without projections and for windows with two depths of vertical projections⁽³³⁾. Window width one-third of wall width

flow which can be used to advantage. Sections 4.2.4 and 4.2.5 of the *CIBSE Guide F: Energy efficiency*⁽³⁴⁾ briefly describe these; *Man, Climate and Architecture*⁽³³⁾ also gives a useful discussion.

The shape of open area itself is less critical for ventilation flow. On still days, buoyancy-driven ventilation is theoretically greater the taller the opening, but two smaller openings vertically above each other are just as effective and more controllable. Care should be taken to avoid draughts near occupants.

2.2.6.4 Location

The location of openable windows, in terms of the position in the wall and spacing vertically and horizontally, has an impact on air movement and, to a lesser extent, on ventilation flow rate. Full-scale monitoring carried out at BRE⁽²⁹⁾ showed that, from the point of view of air quality, the position of the window in the wall had little effect on either overall ventilation rate or local variations within the room. However, window position does affect air movement and temperature, both of which contribute significantly to the sensation of 'freshness'. It was concluded that draughts near occupants at the working level are reduced by using high-level opening lights (e.g. small, controllable openings) for background ventilation in cooler weather, with larger, openable panes above sitting head-height desirable in warm weather for increased ventilation and air movement.

The more the opening area can be evenly spread along the horizontal, the greater the ability for control to achieve adequate ventilation and avoidance of draught

Where there are windows in one wall only, greater air movement (and, therefore, improved comfort) can be achieved⁽³³⁾ on warm days by providing two openings, one upwind and the other downwind, to take advantage of the small pressure gradient along the façade when the wind blows obliquely towards the façade (see Figure 2.40). With cross ventilation, greater air speeds can be achieved where the air stream has to 'change direction' between suitably located inlet and outlet (i.e. in adjacent walls).

2.2.6.5 External and internal shades

External and internal blinds (see section 2.3.4) can affect airflow by providing a resistance to flow. More significantly, poorly designed internal blinds may rattle prompting occupants to close the window which will result in inadequate ventilation. External blinds or shading are very effective in avoiding overheating on sunny days by reducing solar gain.

2.2.6.6 Security, ventilation and night cooling

There can be a conflict between security and good ventilation. Large, open windows can present a security risk, particularly on the ground floor. This is particularly important for night ventilation for cooling the fabric during warm weather.

2.2.7 Provision for installation and maintenance

Accumulation of dirt during the life of a building leads to the deterioration of opaque surfaces and to a reduction in the light reflected. The transmission of light is reduced by soiling of transparent or translucent materials. As a result, the original daylighting achieved when the building was in pristine condition will be reduced with time.

To allow for the effect of dirt on glazing, the predicted daylight factor is modified at the design stage by a maintenance factor (M), which attempts to take account of the geometry and location of the glazing, along with a notional cleaning schedule of once every six months. Values of M are given in appendix A1.2.

Although maintenance factors can and are applied during the design process, it is essential that the designer gives careful consideration to the provision of access for routine cleaning of the glazing surfaces, both within the building and outside. It is also necessary to take account of the health and safety regulations relating to safe access. The Construction (Design and Management) Regulations 1994 (CDM Regulations) require

the designer and the contractor to satisfy the planning supervisor about the design and methods of installing and maintaining the components that make up a construction project. The designer must ensure any design is buildable and that it gives adequate regard to:

- avoiding foreseeable risks to health and safety of any person at work carrying out construction or cleaning work
- combating at source risk to health and safety of any person at work carrying out construction or cleaning work
- giving priority to measures that will protect all persons who may carry out construction or cleaning work at any time.

Designers need also to ensure that the designs include adequate information about any aspect of the project that might affect the health and safety of any person at work carrying out construction or cleaning work. They must also cooperate with the planning supervisor and any other designer who is preparing any design in connection with the same project.

To assist designers, the Construction Industry Research and Information Association has produced *CDM Regulations — work sector guidance for designers*⁽³⁵⁾ to assist in identifying the hazards in relation to the health and safety of construction workers and those affected by construction work.

2.3 Window components

2.3.1 Choice of glazing type

Glazing materials⁽³⁶⁾, usually glass but sometimes specially developed plastics, are available in a wide range of thicknesses, in clear or tinted form, in single or multiple glazed configurations, all combining to provide the specifier/designer with a wide range of performance options. The range of glazings available is being added to all the time as new developments are introduced in the market place.

Quite often the specification required for a particular glazing application has to be a compromise. On the one hand, the desire for maximum light transmission and a low total solar radiant heat transmission needs to be coupled with a high level of thermal insulation (see section 2.3.2) and a good quality view out of the building. Specifications may include glass to provide special fire resistance and protection levels coupled with a high degree of acoustic insulation and an ability to withstand mechanical impact. There may also be a requirement to provide anti-surveillance screening and visual privacy for the building occupants. Fortunately for building specifiers and designers not all of these will apply simultaneously.

It is convenient to divide glasses into six main types, not mutually exclusive, which can be used in a variety of combinations to achieve the desired final performance characteristics:

- (a) clear
- (b) body-tinted
- (c) coated or surface-modified
- (d) textured and patterned
- (e) wired
- (f) laminated.

Almost all these types of glass can be made available in single or multiple glazed forms with some or all panes enamelled, toughened or laminated. They are also mostly available in a wide range of thicknesses for architectural applications. The thickness can be as low as 2 mm for some types and up to 25 mm.

Appendix A1.1 provides some typical performance data for a representative range of glass types. It is, however, strongly recommended that the manufacturers' literature is consulted for up-to-date data on performance,

Figure 2.41 Spectral transmission curves for clear and low-emissivity glazing. The reduced long-wave transmittance gives low-emissivity glass better insulating properties

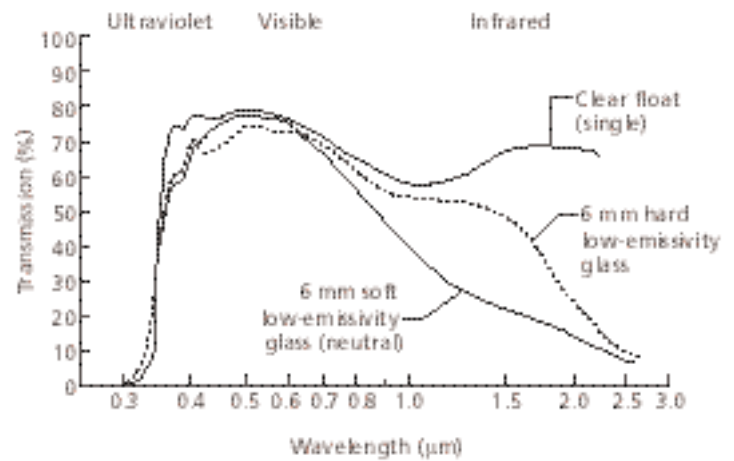

availability and the compatibility of different combinations and treatment (i.e. laminating, toughening, fabrication into multiple glazing units).

Clear glass provides a high transmission of daylight but also allows a high proportion of solar radiant heat to pass through it into a building. Most of the developments in glazing types over the past 40 years or so have been directed at modifying (reducing) the solar radiant heat transmission characteristics of clear glass.

2.3.1.1 *Body-tinted glasses*

These are glasses where the basic clear glass formulation is modified by adding small amounts of additional materials into the mix to produce glasses which have different light and solar radiant heat transmission characteristics coupled with different colours which go through the total thickness of the glass. This means that the thicker the glass the lower the light and total radiant heat transmission.

Typical colours are green, grey, bronze and blue. Green tints are achieved by increasing the proportion of iron oxide in the glass mix (or frit) while grey is achieved by adding cobalt oxide. Selenium oxide produces the bronze tint. For the blue tint additional cobalt oxide is added.

2.3.1.2 *Coated and surface-modified glasses*

Developments in surface chemistry and coating technology have led to a wide range of coated glass and glasses where the surface characteristics can be modified to give a wide range of light and solar radiant heat transmission characteristics in a range of combinations including colour. The majority of the coated glasses rely on microscopically thin layers of metallic oxides in various combinations to enhance the reflective properties of the treated surface and so reduce the solar radiant heat transmission of the glass. These glasses have performance characteristics that are generally independent of pane thickness. They can also be incorporated in multiple glazing and, in some cases, are only supplied as a minimum specification in combination with another glass as a sealed double glazing unit.

Most coated glasses are produced by placing standard sized sheets of clear or body-tinted glasses into a vacuum chamber where the metallic coatings are applied. Surface-modified glasses are manufactured as a continuous process on the float manufacturing process using clear float glass as the base glass.

Coated glasses and surface-modified glasses not only have modified light transmission and total solar radiant heat transmission properties, but also acquire modified surface emissivities which result, where used in multiple glazing combinations, in enhanced thermal insulation characteristics (see Figure 2.41). Some surface-modified glasses are designed to have high light transmission and solar radiant heat transmission with the appearance of clear glass; when incorporated in double glazing their insulation performance is comparable with conventional triple glazing.

Clear, body-tinted and surface-modified glasses can be regarded as environmental control glasses. They have a significant influence on the daylighting, the solar gain experienced in a building and its heat loss characteristics which, in combination, will improve the visual and thermal comfort of the occupants and the energy efficiency of the building.

- 2.3.1.3 *Patterned glasses* These glasses are manufactured on the 'rolled' process where a ribbon of semi-molten glass is passed between metal rollers one of which has the required pattern engraved upon it. Heavy patterns and light textures can be applied in this way. A wide range of patterned and diffusing options can be produced.
- 2.3.1.4 *Wired glass* A similar process is used except that two ribbons of glass are passed between metal rollers with a wire mesh sandwiched between them and the whole fused together while the glass is still in its semi-molten state.
- Depending on the thickness of the wire used in the mesh, this type of glass can offer fire-resistance performance or, with thicker wire, fire resistance combined with protection against injury in the event of human impact with the glazing.
- 2.3.1.5 *Glass blocks* Glass blocks are used in a variety of situations as an alternative to conventional glazings. Panels of glass blocks can be used as structural elements. A wide range of patterns and performances is available.
- While glass blocks are effectively double-glazing units with wide air spaces, the insulating performance will frequently be inferior to that of a conventional window. This is because of edge effects caused by the mortar joints used to bond the blocks together to form a panel. The light and heat transmission characteristics will also be influenced by the mortar joints and the glass edges of the blocks in a panel.
- 2.3.1.6 *Laminated glasses* These glasses are produced by sandwiching a sheet of plastic between sheets of glass (multiple laminates are quite common) to give the resulting glass product enhanced safety characteristics in the event of physical impact or improved resistance to vandal attack. Suitable tinted laminates can be used to create visual effects. UV protection glasses can be produced in this way. By using laminate materials that intumesce in the presence of heat, glasses can be created which give protection from the radiated heat of a fire, and control smoke and flame spread.
- The maximum size of glass panes available from the manufacturer depends on a range of factors: for example, thickness, glass type, whether it is annealed or toughened and whether a double glazed combination is required. The manufacturer should be consulted for specific examples. However the following sizes are unlikely to be exceeded:
- annealed glasses: 2.4×4 m
 - toughened glasses: 2×4 m
- 2.3.1.7 *Emerging technologies* The possibility of devising variable performance glazing in which the glass responds automatically to an environmental stimulus⁽³⁷⁾ has been the dream of many architects for decades. There are two ways to achieve this: with a glass that responds directly and with a glass that is activated through an intermediate control stimulus.
- The direct-response glasses are the so-called thermochromic and photochromic glasses responding to temperature or solar radiation, respectively. Photochromic glass has been used successfully for sunglasses for many years and, in principle, could be used for windows. Most of the glasses currently available, however, are not suitable because their response (darkening) is better at lower temperatures and it is likely that the reverse visual response would be desirable for building applications.

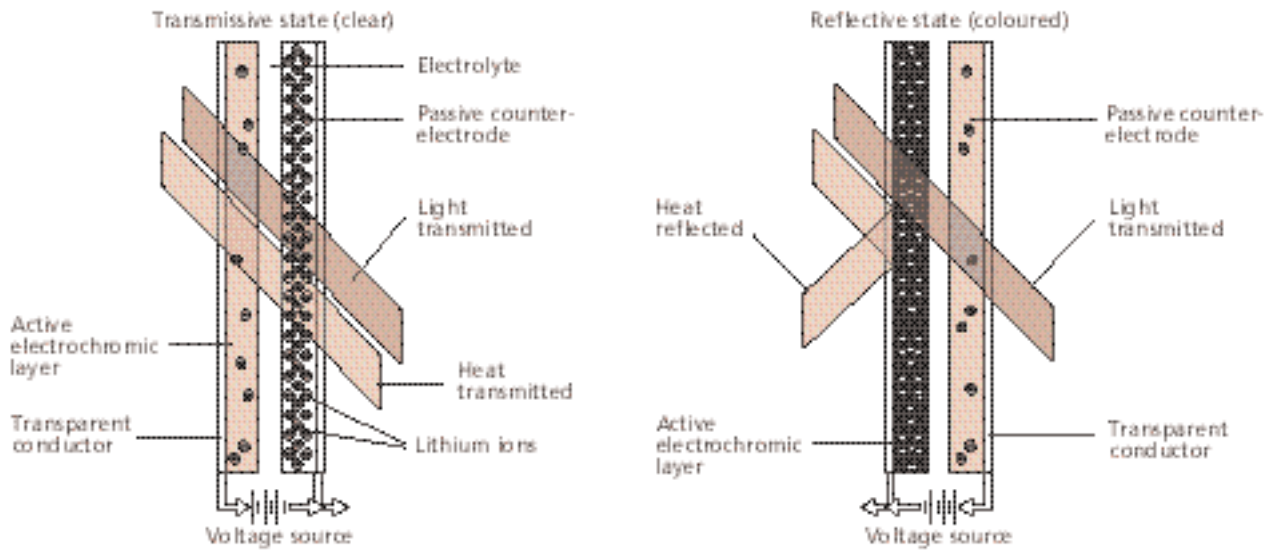

Figure 2.42 Cross section through electrochromic glazing

- Electrochromic glass (see Figure 2.42) responds indirectly to an environmental stimulus, e.g. temperature or light. Coatings that can be sputtered onto float glasses have been developed, e.g. tungsten oxide in multi-layers in combination with a solid electrolyte. By applying a small electrical current the visual and thermal characteristics of such a glazing system can be controlled.
- Photovoltaic glass can generate electricity from the incident solar radiation by means of special coatings. There is already a limited range of products available for architectural applications in the form of cladding for roofs, canopies and spandrel areas.

2.3.2 Light and heat transmittance of glazing

All the glass types referred to in section 2.3.1 can be specified in different combinations to give a wide range of performance options. To ensure that sufficient daylight is delivered into a space the visible transmittance is critical (see section 2.2). This, however, has to be balanced against all the other functions of the windows.

In cold climates, reduced heat loss is important. So although single glazing will always give the highest light transmittance it may be necessary to opt for multiple glazing with a lower heat loss (U-value). The key parameter is the ratio of light transmittance to U-value. A glass combination with a high ratio gives reduced heat loss for the same daylight contributions.

Similarly, where solar control is a high priority, the key parameter is the ratio of light transmittance to total solar transmittance (see Figure 2.43). Some of the recent developments in selective reflective coatings can result in glazing combinations with high levels of daylight transmittance, relatively low heat gain characteristics and high levels of thermal insulation.

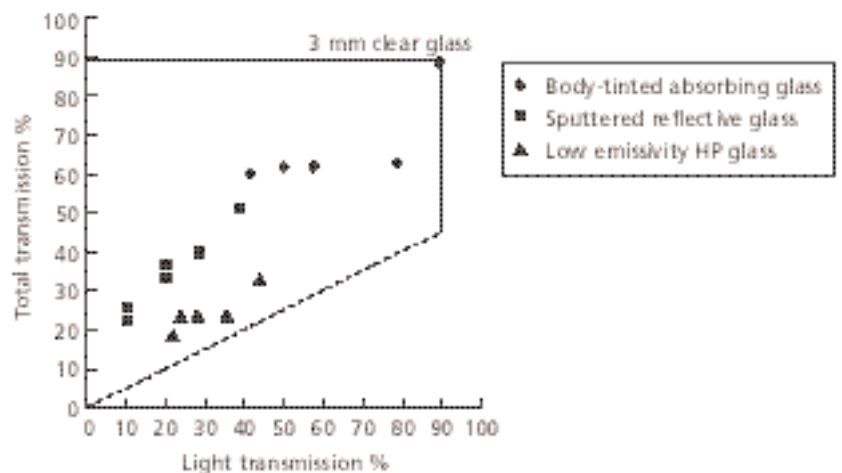

Figure 2.43 Light and total radiation transmittances for a range of glazing types

Some heavily tinted glazings — body-tinted, coated or those using tinted laminates — can affect the view out of a building. Light transmissions below 32-38% tend to be regarded as unsatisfactory depending on the sky type⁽³⁸⁾.

Where tinted glasses are used (normally in commercial buildings), the colour of the glass in the windows tends not to affect occupant perceptions⁽³⁹⁾ although in a model study⁽⁴⁰⁾ a preference for a warm colour such as bronze was noted. However, this is only true if all the glass that can be viewed simultaneously is of the same colour and no windows are open. An outdoor view through an open window or clear glass will reveal the true nature of tinted glazing and may make people less satisfied with it.

In climates where heat gain and heat loss are required at different times of the year, variable transmission glazings may be an advantage. These could take the form of glazing incorporating mechanically adjustable shading devices or active systems such as electrochromic glazing.

Glass manufacturers' catalogues usually quote normal transmittance values (incoming light perpendicular to the windows). For daylighting applications it is usually more meaningful to use the diffuse transmittance values (see Appendix A1.1).

2.3.3 Case study: reflected solar glare



Figure 2.44 Solar reflection from a sloping façade in Aylesbury

Glare or dazzle can occur where sunlight is reflected from a glazed façade. Figure 2.44 shows a building in Aylesbury where reflections from the sun were affecting road users on the nearby roundabout. This problem occurs with low altitude sunlight where there are large areas of reflective tinted glass (see Figure 2.45) but also if, as in the Aylesbury building, the glazing slopes back at up to 35° from the vertical so that high altitude sunlight can be reflected along the ground (see Figure 2.46). Thus solar reflection is only a long-term problem for some heavily glazed (or mirror clad) non-domestic buildings. A glazed façade also needs to face within 90° of due south for significant amounts of sunlight to be reflected.

If it is likely that a building will cause solar glare the exact scale of the problem should be evaluated. This is done by identifying key locations, such as road junctions and windows of nearby buildings, and working out the number of hours of the year that sunlight can be reflected to these points. The BRE Information Paper IP 3/87⁽⁴¹⁾ gives full details.

Solar reflection can be remedied at the design stage by reducing areas of glazing, substituting clear or absorbing glass for reflective glass, reorienting the building, or replacing areas of tilted glass by vertical or nearly horizontal glazing. Alternatively, some form of opaque screening may be acceptable, although this usually needs to be larger than the glazing area. With the Aylesbury building, trees were planted to lessen the risk of glare.

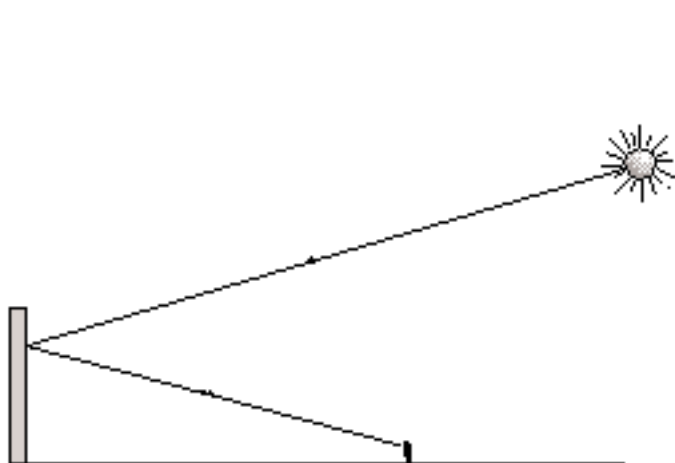

Figure 2.45 With a vertical façade, solar reflection is usually only a problem if the sun is low in the sky

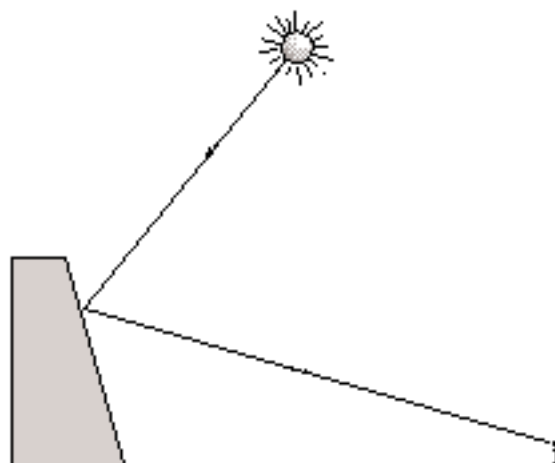

Figure 2.46 A sloping façade can reflect high angle summer sun along the ground

2.3.4 Choice of shading devices

External shading such as blinds or brise soleil are particularly effective in reducing solar gain. Mid-pane blinds are also very effective. Internal shades or blinds will reduce internal gains but are less effective because once solar radiation has penetrated the glass it will cause some heating of the interior of the building. The blind finish is important; reflective blinds may (with clear glass) reflect heat back out, while absorbing blinds will become warm quickly.

Fixed devices require careful design for the site to avoid reducing daylight which could lead to increased use of electric light. Adjustable devices have the advantage of allowing maximum daylight penetration while providing sun shading when required. They can be controlled manually or automatically. Manually adjusted blinds or shades can be set by the occupant as required, but there is a tendency for them to be left down which results in unnecessary use of electric light. Automatic blinds overcome this problem, but special attention needs to be given to their control to avoid user annoyance with frequent movement of the blinds.

With internal blinds, it is important to take into account potential problems which could undermine their effectiveness. Such problems include interference with the open window; restricting natural ventilation air flow; blind rattle or sway in the airflow; blinds positioned too far back

Figure 2.47 Types of external (numbers 1-10) and internal (numbers 11-15) shading devices (see also Table 2.9)

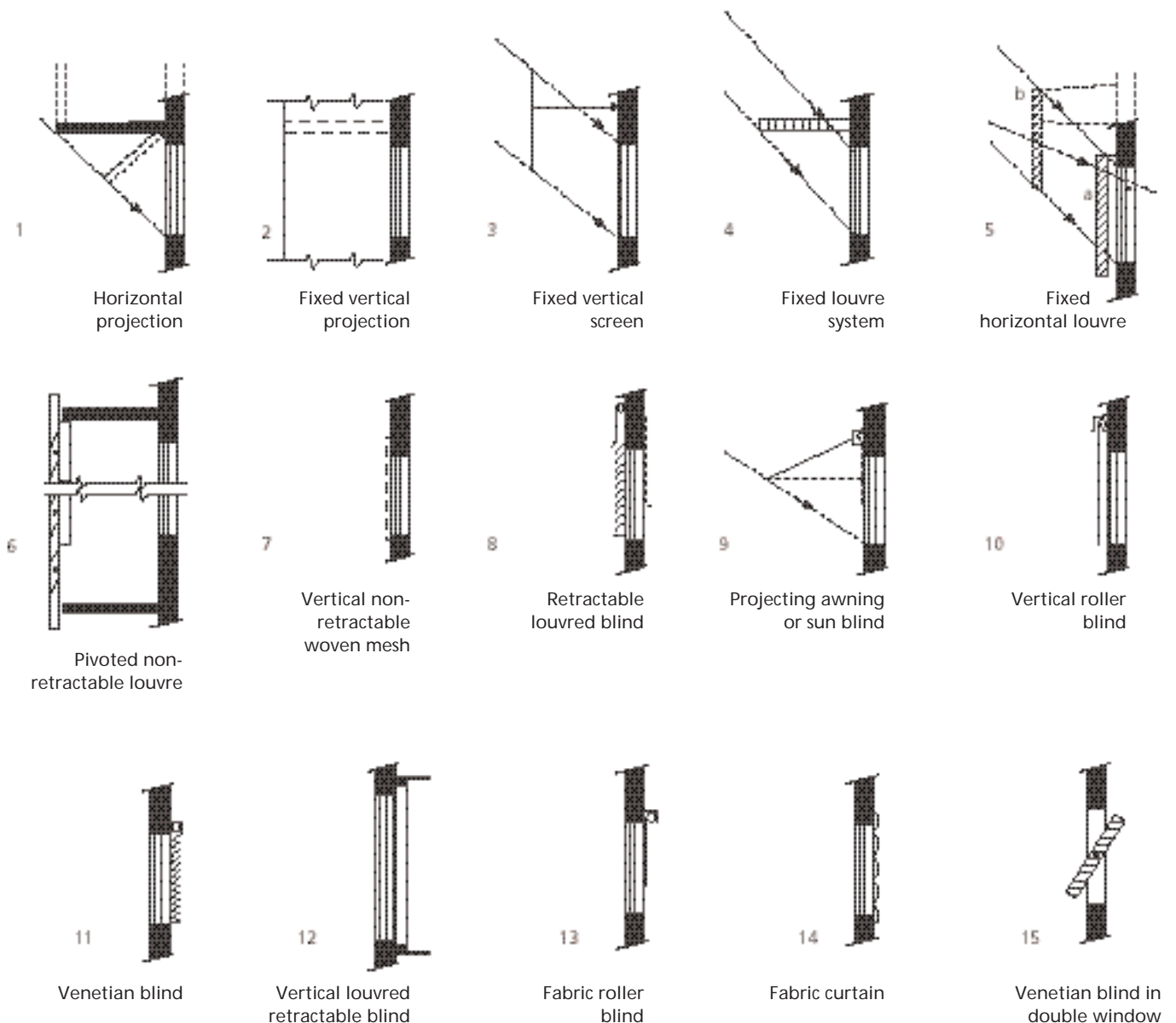

from the pane allowing sunlight to fall on the interior window ledge; poor, inaccessible or inconvenient user controls; and the lack of an obvious 'owner' to operate the blind.

Figure 2.47 shows the main types of shading devices available, while Table 2.9 summarises their applications, advantages, disadvantages, cost implications and maintenance considerations.

Trees and other plants can also be used to provide shading, but care must be taken to avoid root damage to structures if the trees are large⁽⁴²⁾. Deciduous varieties offer the advantage of shade in summer but moderate solar access in winter. BRE Digest 350⁽⁴⁾ gives the transmittance of common tree species in full leaf and in bare branch form.

Table 2.9 Description and applications of typical shading devices

Type of shade	Applications, advantages and disadvantages	Cost implications and maintenance considerations
External shading devices (excluding heat-absorbing and reflecting glasses)		
(1) Horizontal projections (e.g. canopies or balconies, as for domestic flats) fixed as integral part of external fabric	In equatorial countries and for south-facing windows in temperate climates to admit sunlight in winter and exclude it in summer. For other orientations and to give effective shade over a long season, they have to project farther than height of window, cutting off skylight in dull weather. Sloping canopy reduces projection but further reduces skylight and adversely affects the view. Other uses: to reduce glare from sky (e.g. as 'eyebrow' for hospital ward windows) or reflections in shop windows in association with sloping or curved glass	Cost high for benefit in solar shading, unless provided for other reasons. Normal building maintenance applies, but external access to windows by cradle could be difficult unless top surfaces can be used as walkways
(2) Fixed vertical projections or screens. May be combined with (1)	Can be used effectively with east- to west-facing windows, especially if the vertical fins are inclined towards the north to screen sunlight coming from the south	Cost may be less than for (1), but still high. If combined with (1), same considerations about access for maintenance apply
(3) Fixed vertical screens in front of windows and parallel to face of building. Combined with (1), may reduce projection of canopy	Give useful shade and dissipation of heat absorbed by shade material. Depth, spacing and position of bottom edge of screen depends on protection desired	Cost implications and maintenance considerations as for (1)
(4) Fixed louvre system in form of canopy or sun visor. Aluminium version available in made-to-measure lengths for fixing to building structure	Can be designed to give similar shade to that of solid canopy but has the advantage of reduced weight and less obstruction to diffuse skylight	Maintenance considerations in general as for (1). Aluminium types lacquered or anodised to reduce maintenance, but regular cleaning desirable to preserve appearance of louvres
(5a) Fixed horizontal louvre system with long axis of louvres parallel to plane of window	Gives effective shading for a wide range of conditions depending on setting of louvre, i.e. angle and spacing of blades. Can seriously restrict view: the degree of restriction will depend on the setting of the louvres	Maintenance and external access could be problem, also opening of windows, unless sliding or open-in types used
(5b) As (5a) but can be fixed farther from window as for (3)	Comments as for (3)	Access and cleaning of windows less of a problem than (5a)
(6a) Pivoted non-retractable horizontal and vertical louvre systems. Proprietary systems of robust design with fins, hand-operated or fully automated	An improvement on fixed systems but unless vertical louvres are fully automated, they require periodic adjustment to provide optimum shade with changing sun paths. Can seriously limit view	Initial costs expensive but offset by long life. Motorised versions available. Could give cleaning and maintenance problems if applied to existing windows
(6b) As (6a) but for rooflights	As (6a). A two layer system can create an egg-crate array and provide excellent solar control all day. A single layer may need to be fully shut at certain periods to maintain full solar shading. Reinforcement is needed to prevent droop due to natural deflection and snow loading	Maintenance access direct from roof reduces the need for scaffolding. Periodic adjustments of limit switches needed and annual cleaning suggested
(7) Vertical non-retractable woven mesh in flat copper wire to predetermined pitch to deal with high or low angle sun	Reduces solar gain effectively throughout year but gives permanent reduction in diffuse skylight; also restricts view. Easy to install: can be fixed direct to window frame	Initial cost rather expensive. Requires periodic cleaning to prevent mesh becoming blocked with dirt. Available in horizontal frames to ease maintenance

2.3.5 Interiors with display screen equipment

The use of display screen equipment (DSE) is now widespread. In designing windows, it is important to consider all spaces where DSE is likely to be used, not just offices⁽⁴³⁾. For example, factory and workshop spaces often contain DSE, and the reception areas of buildings usually have DSE as well as large areas of glazing. The CIBSE Lighting Guide LG3 *The visual environment for display screen use*⁽⁴⁴⁾ gives comprehensive advice.

In interiors with DSE, occupants are still very positive about having windows and daylight. For example, a German study found that DSE users preferred to be near windows⁽⁴⁵⁾. They value contact with the outside world, particularly a view out; and an external view can help relax the eyes from time to time.

Type of shade	Applications, advantages and disadvantages	Cost implications and maintenance considerations
(8) Retractable louvred blinds, usually in aluminium. Can be retracted by reefing or on roller	Give flexible control of incident sunlight as for internal types. On dull days or in stormy weather, blinds can be completely retracted. Useful for buildings where fully controlled internal environment is required. Complete automatic operation available by solar-activated switching. Can restrict view depending on setting of slats. Can be completely closed for night-time black-out	Cost and maintenance vary widely depending on degree of control and method of fixing. May need cradle for external access, but blinds are available with direct access from the room
(9) External projecting awnings and sun blinds in large range of fabrics and in woven plastics, ranging from near opaque to translucent. All retractable on rollers	Wide application from domestic to commercial buildings, including shops. Allow good control of sunlight and, being retractable, do not restrict skylight on sunless days. In intermittent sunlight, the more opaque materials may cause difficulties unless the blinds are under fully automatic control. Subject to damage unless retracted in high winds	Most systems give easy removal of rollers and fabric, but rollers longer than about 3 m can give problems if access for cleaning and maintenance is by cradle. For other than domestic applications, planned maintenance is advisable, including cleaning of cloths
(10) External vertical roller blinds. Usually have guides at edges to give more stability in high winds	Give complete shading, if required, or can be partly drawn to leave vision strip at bottom of window. Difficulties may arise with outward opening lights. Open-weave types can give limited view through mesh: tend to restrict ventilation when fully drawn	Similar to retractable blinds (louvred) requiring periodic adjustment of electronic types. In situ cleaning is difficult, but rollers and cloths easily removed given external access
Internal shading devices		
(11) Venetian blind with plastic or aluminium alloy slats, fully retractable and with variable tilt to slats. Manual control by cord or rod or fully automatic	Domestic application, schools, hospital, offices etc. Easy to install and maintain. Gives flexible shade control with good shielding against direct sunlight if required; admits ventilation air more effectively than fabric blinds. Difficulties may arise with inward-opening lights	Manually operated types inexpensive but susceptible to misuse. Automation of cleaning systems and ease of removal and replacement tends to bring down maintenance costs
(12) Vertical louvred blinds, fully retractable. Made to measure with wide choice of slat material. Can be automated	Can be set to exclude sunlight over a range of conditions and allow good penetration of skylight. Provide reasonable view if set normal to face of window. Useful for low angle sun through east- or west-facing windows. With south-facing windows, slats need constant adjustment to follow sunpaths. Difficulties may arise with inward-opening lights	Tend to be expensive to automate. As with (11), they are susceptible to misuse with possible expensive repairs
(13) Fabric roller blinds with a wide choice of material, fixed to window surround or window frame. Can be automated	Simple to operate but tend to restrict ventilation when fully drawn. Wide range of solar control. Difficulties may arise with inward-opening lights	Easy to maintain. Some fabrics are vinyl finished to help preserve appearance. Some manufacturers guarantee their blinds against fading
(14) Curtains of fabric including aluminium coatings on surface facing window. Fixed to window frame or surround. Obtainable with a range of weave densities	Can be used with most window designs, but large pivoted windows may cause problems. Give flexible control for low-level sun and against sky glare. Difficulties may arise with inward-opening lights	Wide range of costs according to material. Fading of ordinary fabrics reduced by lining side towards glass
(15) Venetian blinds fixed between double windows with special controls to retract blinds and vary tilt of slats	Better protection against solar heating compared with similar blinds mounted on room-side of window. Enclosure helps to keep blinds clean	Maintenance of operating gear depends on ease of access to blind system. Increase cost of window design
(16) Pleated paper blinds for fixing in double windows. Material can be translucent or opaque	As for (15)	As for (15) but less costly

The Health and Safety (Display Screen Equipment) Regulations 1992 require that 'windows shall be fitted with a suitable system of adjustable covering to attenuate the daylight that falls on the workstation'. Adjustable shading which the occupants can control is usually the best option; people tend to resent shading systems that operate automatically.

Conventional venetian blinds work well because they can be adjusted to retain a view while restricting incoming sunlight and sky glare. Blinds need to fit the window reveal snugly, without gaps through which sunlight can penetrate. For east- or west-facing windows, vertical slat louvre blinds cut out sunlight while retaining a view out and allowing some incoming diffuse skylight. However, problems may occur if the blind material is translucent: a blind illuminated by sunlight can be very bright, causing reflection in screens and distracting glare. This can also occur with other types of non-opaque shading device when sunlight enters. Translucent roller blinds, net curtains and diffusing glazing all act as secondary sources of glare and screen reflections.

Tinted solar control glazing and window films reduce sky glare and incoming solar heat, but they are not effective at controlling glare from the sun. If sunlight is likely to enter a space with tinted glazing, extra shading will be necessary, usually adjustable blinds. Heavily tinted glazing can make a room, and the view out, look dull.

The risk of excessive blind use, resulting in little daylight penetration, can be lessened using the following techniques:

- give occupants a good view out as an incentive to raise the blinds
- avoid overglazing, particularly where the occupants can see large areas of sky
- use light shelves (see section 2.3.6) or overhangs to reduce the need for blinds
- maintain the blinds so that they are easy to operate even with the windows open
- ensure that occupants know how to operate the blinds
- instruct security staff or cleaners to raise the blinds after or before each working day.

Although The Health and Safety (Display Screen Equipment) Regulations 1992 do not specifically mention rooflights, careful design is required if rooflit spaces contain DSE. The main problems are sunlight coming through the rooflights and reaching working areas and rooflights reflected on the screens. Both problems are more likely to occur in rooms that are long and/or wide compared with their height. Dome type rooflights with a deep, opaque upstand or skirt are suitable. Northlights (either vertical or sloping) will restrict sunlight entry, but may cause screen reflections unless all the DSE can be oriented so that none faces the glazing. Other rooflight types will need shading if they let sunlight reach a screen or if they are visible at less than 15-35° to the horizontal from a workstation — the angle depends on the category of DSE use⁽⁴⁴⁾. Possible shading options for rooflights are:

- (a) motorised blinds (effective but expensive)
- (b) fixed louvres or baffles
- (c) diffusing glazing if sunlight is the problem, but this may make some screen reflections worse (in an existing building it is possible to check whether this approach will work by whitewashing the offending rooflight)
- (d) manually operated roller blinds in a smaller building, but the blind material should be almost opaque if screen reflections are occurring
- (e) prismatic glazing or film (see Figure 2.48).

Figure 2.48 Prismatic glazing at the Billingsgate building, London, a rooflit dealing space



In general, externally mounted shading devices are better than internally mounted ones at controlling incoming solar heat gain. However, internally mounted shading may stay clean longer. Provision must be made for cleaning and maintaining shading devices.

Atria represent a special type of rooflit space. Sunlight entering an atrium can reach adjoining spaces, particularly those on the top floor of the building. This can be controlled by using the rooflight shading techniques described above, or by introducing blinds or baffles between the atrium and the adjoining space. Alternatively, it may be possible to modify the geometry of the atrium glazing to reduce sunlight penetration. If an atrium contains reception areas with DSE, a canopy enclosing these areas will control high daylight levels and make it easier to see the screens.

In daylit spaces, screen orientation is very important. Where possible, users of screens should look in a direction parallel to the line of the window wall, not towards or away from it, and they should be at least 2 m from the windows. This may require careful planning of workstation positions, and hence circulation routes. Where windows are holes in the wall rather than continuous ribbon glazing, workstations can be placed so that the DSE users or their screens face blank areas of outside wall⁽⁴⁶⁾.

2.3.6 Daylight redirecting systems

Daylight redirecting systems such as light shelves, prismatic glazing and mirrored louvres work by redirecting incoming skylight and sunlight⁽¹⁵⁾. They can provide a degree of shading with better utilisation of sunlight and can improve the uniformity of daylight in a space.

Consider daylight redirecting systems where:

- (a) visual requirements within the space are especially stringent, for example if there is display screen equipment
- (b) there are large external obstructions outside the room (this could include rooms leading off an atrium)
- (c) much sunlight is available, typically a south-facing window wall in a sunny location
- (d) the space is too deep to give adequate uniformity of lighting with conventional windows (see sections 2.1.2 and 2.2.1)
- (e) other room geometries where conventional windows or rooflights would give unacceptable gloomy areas within the spaces.

Table 2.10 summarises the performance of daylight redirecting systems. In general, they do not increase the amount of light available and, with the simpler static systems, the light levels at the back of the room will not be significantly higher than for an unshaded window. For adequate daylighting, the average daylight factor should be sufficiently high (see section 2.2.2). Care needs to be taken to avoid reflected glare, for example by keeping the redirecting elements above eye level and testing to see that no sun is redirected downwards.

Table 2.10 Summary of performance of daylight redirecting systems

System	Enhances core illuminances	Uses sunlight effectively	Works in cloudy conditions	Glare control	Allows view out	Reduces solar gains	Low cost	Easy maintenance
Sun tracker and light pipe	**	**	—	?**1	—	—	—	—
Light tube without sun tracking	*	*	*	?*1	—	—	**	**
Fixed louvres`	—	?*2	*	?*2	?*2	**	*	?**3
Reflective blinds	—	?*	**	**	*	*	**	—
Light shelf	—	*	**	*	**	**4	*	—
Coated prismatic (sunlight admitting)	*	*	*	**	—	*	—	?**3
Coated prismatic (sunlight excluding)	—	—	*	**	—	**	—	?**3
Prismatic film	—	*	**	*	—	—	**	?**3
Stacked near rectangular prisms	*	*	**	—5	*	—	?*	?**3
Holographic film	?*	*	?**	?	*	—6	?*	?**3

System meets the stated requirement: ** well, * partly, ? potentially, — poorly,

1 Depending on emitter design; 2 Depending on louvre profile; 3 If installed inside double glazing; 4 If an external shelf is fitted; 5 Unless installed as tilting louvres; 6 Unless installed with secondary shading

Maintenance must be considered at the design stage. Light shelves, mirrors and glazing systems all collect dust and dirt, which look unsightly and degrade their performance.

2.3.6.1 Case study: light shelves

The South Staffordshire Water Company office building has external and internal light shelves (see Figure 2.49). Near the window, the shelf provides shading, but areas deeper within the office still have a view of sky through the clerestory window. Sunlight reflects off the top of the light shelf onto the ceiling and is diffused into the depth of the office. With the light shelf the available daylight is more uniformly spread, improving visual conditions within the office, especially near the window.

In summer, the light shelf blocks high altitude direct sun but in winter it allows some sunlight to pass directly over it. Some occupants have placed boxes and even umbrellas on the light shelf to block this winter sun. Some



Figure 2.49 External and internal light shelves on the South Staffordshire Water Company office building. Note the sunlight reflected off the ceiling

additional shading above the shelf, such as venetian blinds, would help to avoid solar glare in winter for occupants deep in the room.

The internal light shelf is horizontal. The external shelf tilts upwards, which may increase daylight penetration, but gives reduced shading. Both internal and external shelves are highly reflective, and the semi-specular surfaces result in improved daylight penetration. The high ceiling also helps the light shelf work effectively.

2.3.7 Exhibition displays and ultraviolet filtering

Sensitive objects such as paintings, textiles and paper are damaged or faded by exposure to light. Some objects are so responsive that exposure to light for a few months will produce a permanent change in appearance. How materials deteriorate under given lighting conditions depends on their chemical composition. The CIBSE Lighting Guide LG8 *Lighting for museums and art galleries*⁽⁴⁷⁾ gives details.

For a given material, three factors affect degradation:

- spectral composition of the light
- illuminance
- period of exposure.

Radiation at the shorter wavelengths (blue and ultraviolet) usually causes the greatest degradation. Ordinary window glass and the standard grades of clear or translucent plastics used for glazing rooflights absorb only part of the ultraviolet radiation in daylight. The spectral transmission curve of float glass is shown in Figure 2.50. Where sensitive objects are displayed, additional filtering will be necessary. Certain chemicals will absorb almost all ultraviolet radiation without affecting significantly the overall transmission or colour of the light. These ultraviolet absorbers can be incorporated in most transparent and translucent plastics.

Cutting out the ultraviolet may not be enough, however, because visible wavelengths can cause some damage. The daylight illuminance in interiors may exceed 1000 lux. For many display materials a limiting level of 200 lux is recommended, with 50 lux for materials very sensitive to light. These values may conflict with average daylight factors recommended in section 2.2 for a satisfactory visual environment. If conservation is a prime factor, this must be taken into account in design decisions on window areas and methods of daylight control.

For a given light source the degradation is a function of the product of illuminance and exposure time. Thus an exposure to 100 lux for 10 hours should cause similar degradation as exposure to 1000 lux for 1 hour. If degradation is a problem, the time for which the material is exposed to relatively high illuminances should be limited. Simple precautions, such as pulling the blinds or curtains when the room is unoccupied, will help. Light-sensitive materials should be placed away from exposure to sunlight or prolonged high levels of skylight.

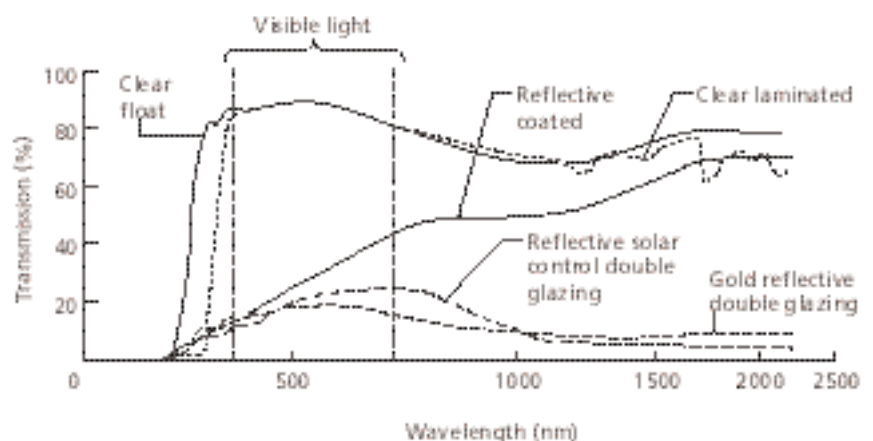

Figure 2.50 Spectral transmittance of clear float glass. Gold reflective double glazing is shown for reference but should not be used for exhibition areas

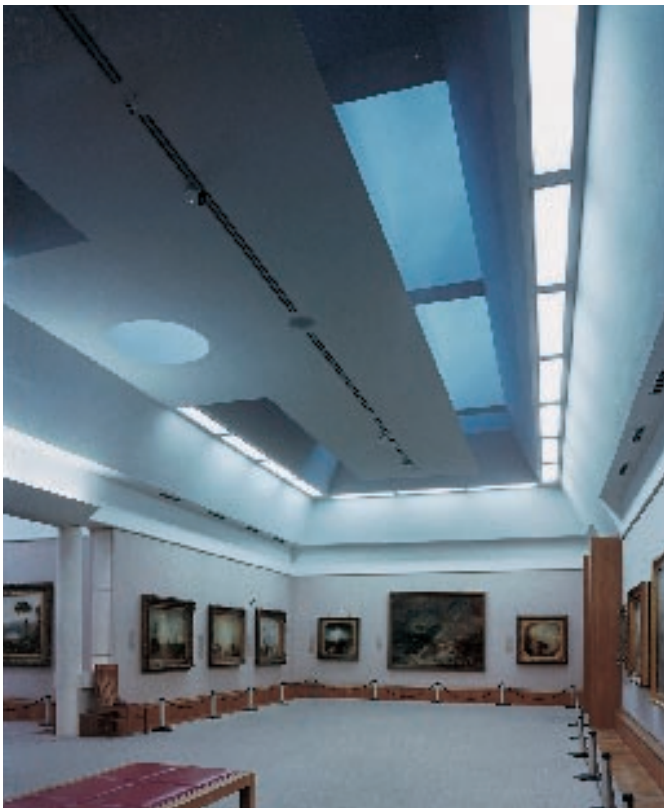

Figure 2.51 A typical gallery view in the Clore Gallery



Figure 2.52 Looking up into the light scoop

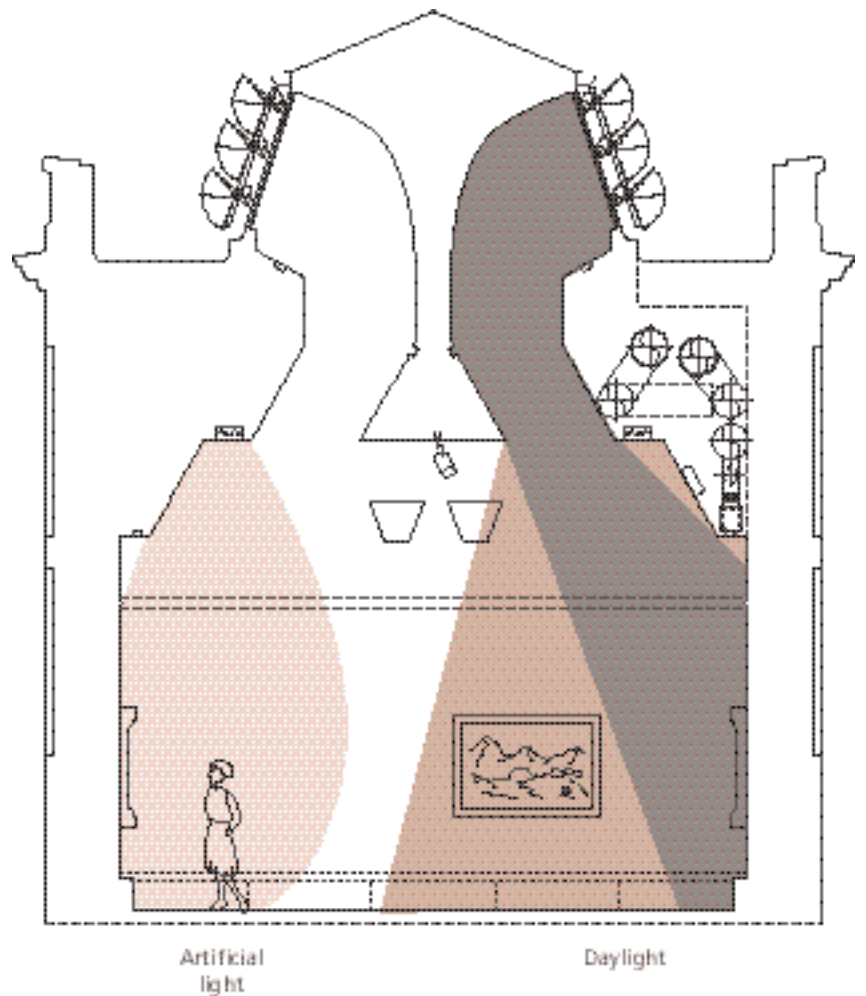

Figure 2.53 Cross section showing scoops and louvers

- 2.3.7.1 *Case study: Clore Gallery* The Clore Gallery, designed by Stirling Wilford Associates to house the Tate Gallery's Turner Collection, was completed in 1987⁽⁴⁸⁾. Light is admitted into the top of the galleries through scoops (see Figures 2.51 and 2.52); all the light falling on the paintings is reflected from surfaces painted with white titanium paint, which reduces its UV content. To control the varying incoming skylight and sunlight the scoops are fitted with aluminium louvres which rotate to admit or block light (see Figure 2.53). The louvres can also be closed completely outside gallery opening hours to minimise exposure. To avoid too static an environment the louvres and dimming of the lighting are controlled in stages, so that there is some variation in the lighting conditions during the day.
- 2.3.8 **Glazing for security** The laminating process enables sheets of glass to be turned into a composite, sometimes in combination with non-glass materials, which is capable of withstanding a range of deliberate attacks.
- BS 5544*⁽⁴⁹⁾ gives guidance on the provision of glazed protection for valuables and personnel. For protection from a range of weapons from shotguns and 9 mm handgun to 7.62 Nato rifles, bullet-resistant laminated glass in accordance with *BS 5051*⁽⁵⁰⁾ can offer solutions. The performance of anti-bandit glasses and bullet-resistant glasses will depend on the make-up of the laminates. Specific performance can be engineered into the laminated glasses by the traditional processes.
- Protection against the results of an explosion — whether the result of an accident or deliberate intent — can be offered by appropriately designed, manufactured and installed glazing. Advice on the appropriate type, thickness and specification of glass for use in safety or security applications should be sought from a specialist.
- In many areas there are national regulations or standards which must be met by the total glazing installation. In England and Wales, The Building Regulations Part N define applications where glazing has to conform to certain mechanical strength standards and size limitations to reduce the risk of injury in the event of human impact with the glazing. These regulations apply to internal and external uses of glazing. In Scotland the equivalent is Part P and in Northern Ireland Part V.
- There are some instances where the glazing may need to have a level of fire-resistance performance. Glass will directly transmit radiation, hence if a fire fully develops within a space, high levels of radiant heat will pass through a perimeter window. This may create a hazardous situation for people or allow the fire to spread by combustion of materials into an adjoining space. Thus a window in a fire wall could be a weak link. However, clear vision through a window in a door or wall can alert occupants of a potentially hazardous situation and allow them to evacuate the building in good time.
- Information on the window size and materials of the building, and its proximity to surrounding buildings or the site boundary with respect to the spread of fire, is provided in The Building Regulations Part B (Parts D and E in Scotland and Parts E and EE in Northern Ireland). The designer is advised to seek expert advice in this important matter.
- Advice on the likely glazing specifications should be sought at an early stage in the design process as many of the laminate solutions will significantly increase the thickness of the glass. The extra thickness (in some instances several centimetres) will increase the weight of the glazing and so require more substantial framing systems. These two factors could significantly reduce the amount of daylight admitted into the building by any proposed window system.
- 2.3.9 **Frames and supporting structures** It is usual, but not universal, for a framing material to be used to fix glass to the building structure. The exceptions are where the glass is fixed directly into a prepared aperture in the building structure or where the glazing forms an integral part of the building structure.

The materials commonly used for framing are timber, aluminium, PVCu and steel. The choice of material can have a significant effect on the total window performance as it influences the cross-section of the framing components; in the case of timber, for example, it is not unusual for 30% of the window aperture to be occupied by the perimeter members of the frames and the intermediate glazing bars. If this is ignored in the daylight evaluations during design there could be significant overestimates of the daylighting within the building.

Similarly, the amount of material in the frame components will influence the thermal insulation properties of the total window. Poorly insulating frame systems, for example, would reduce the benefits of highly insulating glass combinations.

Condensation occurs frequently on the inner surfaces of windows and glazing. If the surface temperature at any point falls below the dew point of the internal air, condensation will occur. As well as the inner glass surface, the edges of sealed units are especially vulnerable due to thermal bridging, and with poorly insulating materials the frames are subject to severe condensation problems. In coupled windows, condensation may develop on the inner surface of the outer glazing if the seal of the inner sash is impaired. Condensation in double glazing units indicates that the hermetic seal has failed. In some circumstances, condensation also occurs on the outer surface of the glazing. In the UK this may happen on clear nights for windows with U-values lower than about 1.5 W/m²K. This is due to the high radiation loss to the night sky and is the same heat transfer mechanism as the formation of dew on frosty nights.

Timber and PVCu framing systems tend to give good levels of insulation whereas aluminium or steel do not unless insulating sections (thermal breaks) are used to thermally isolate the inner and outer components of the frame. The use of reinforcing metal inserts in PVCu framing must be carefully considered because the insulating properties of the frame can be compromised if the reinforcement is badly positioned.

Performance data are given in Appendix A1.1, with typical total window U-values for different frame materials.

The window frame must also be designed to provide adequate support for the weight of glass required. Although not strictly a daylighting matter, it can have an indirect influence on the provision of daylight because of the obstructing nature of framing sections.

In non-domestic buildings there is an increasing use of structural glazing which does not employ frames. The glazing is usually arranged in an array of panes of toughened glass held together by specially designed corner plates bolted through the glass or by suitable adhesives. In either case, the glass façade forms an integral part of the building structure and has to be mechanically attached to it. Sometimes, the façades or roof glazing are bolted to a space frame or tied back to the main structure. It is usual to employ toughened glass to give the necessary stability, mechanical strength and resistance to wind pressures. These structural glazing systems can be made up of single structural glazed panes or incorporate sealed double glazing units. There is little or no obstruction to incoming daylight because they do not have framing systems and the insulation properties are usually much the same as the glass itself, although there could be some small conduction losses through the mechanical fixings — bolts, patch plates etc.

2.3.10 Window furniture and fittings

A wide range of window furniture and fittings is available. A careful choice, taking account of the location and desired function of the window, is essential to ensure that the window can be safely opened and closed when necessary, and provide the desired level of security.

- Usability: window fixtures, handles and locks that can be operated with ease by an average-sized adult should be selected. There are optimum positions for window locks and handles, particularly

in domestic and other locations where children may be tempted to tamper with them. Automatic controls are available for inaccessible windows or where there are specialised requirements, for example disabled users⁽⁵¹⁾.

- **Durability:** a range of metals and plastics is used in the manufacture of window furniture and fittings. Typical metals are aluminium, zinc alloy, brass, stainless steel, plated steel and galvanised steel. Plastics, usually PVCu and nylon, tend to be used mainly for handles and stays. Some minimal maintenance such as lubrication and cleaning will usually be required.
- **Strength:** furniture and fittings must be strong enough to withstand the loadings imposed by users when opening and closing the windows, and also the inevitable wind loading that will occur.
- **Security:** the special glazing referred to in section 2.3.8 should be provided as necessary, but in addition the choice of locking systems, hinges and fasteners will determine the overall resistance of the detailed window design. Where necessary, expert advice should be sought from the component manufacturer.

2.3.11 Noise insulation

In general, sound insulation of building fabric is achieved by interposing mass between the source and the listener; more mass means more insulation. The behaviour of windows and rooflights often needs to be considered in a different way. The details of assembly of glass, frame, seals, sub-frame and fastenings all affect the resultant sound insulation. It is therefore usual to consider all these parts as the window unit and ascribe an insulation value to that. To complicate matters further, putting a window in a wall does not reduce sound insulation in a way that is in proportion to the respective areas. The window produces an extra reduction. This is because sound waves are able to bend and find the weakest link.

2.3.11.1 Principles of sound insulation

- **Mass law:** the sound insulation of a single partition generally increases with the mass of the partition and the frequency of the incident sound. This is known as the mass law and is shown in Figure 2.54. The practical increase in insulation is about 4-5 dB per doubling of mass or frequency.
- **Critical frequency:** at certain frequencies there is a resonant effect which means that sound is transmitted through the partition more than the mass law would suggest. These frequencies are called critical frequencies and are characteristic of the partition⁽⁵²⁾. Critical frequencies for glass tend to be between 1 and 3 kHz which

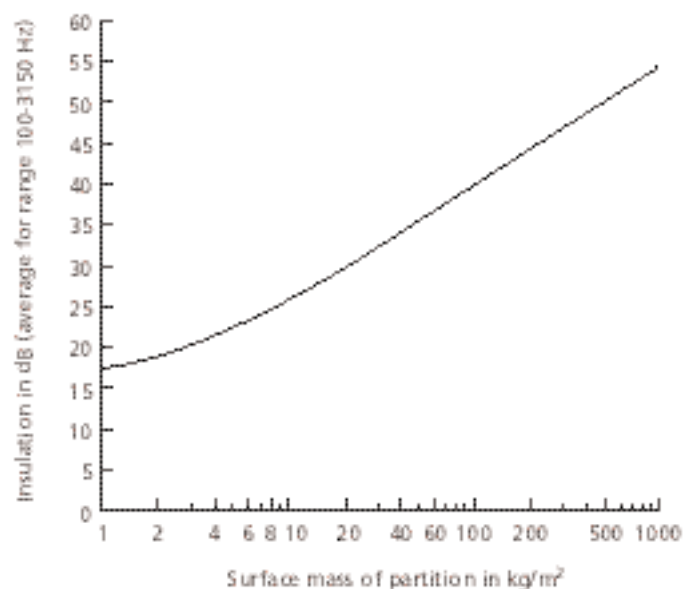

Figure 2.54 Relationship of sound insulation to surface mass for single leaf construction

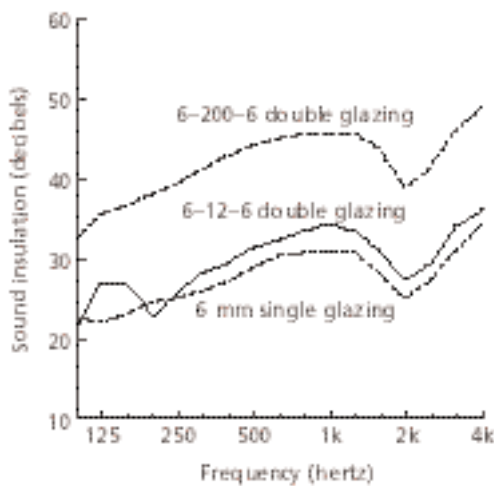

Figure 2.55 The effect of frequency on sound insulation for three types of glazing

2.3.11.2 Practical sound insulation

lies in the range for understanding human speech. Solid walls, glazing and all partitions are subject to this effect. By using different weights of glass in double glazed panels the resonances will be offset.

- Double glazing: if two panes can be acoustically separated the total insulation of the two panes will be a simple addition of the individual values. In practice, all such units are coupled at the edges in some way so the combined insulation is less. Some resonances can occur in the air or gas in the cavity, which will also affect insulation. Figure 2.55 shows laboratory measurements of sound insulation for single and two types of double glazing with different gap widths. The figure shows how insulation increases with frequency, how each has one or more critical frequencies and that the optimum gap is about 300 mm. For extreme situations, as in recording studios, placing the panes out of parallel to each other will help damp down resonances. Placing absorbent material on the surface of the reveals will also assist.
- Laminated glass: glasses laminated with suitable laminating materials offer increased insulation when glazed into double glazing units.

To determine a suitable window for a building the designer needs to predict the likely external noise climate on the site and a desired noise climate inside. The external envelope with windows and rooflights comes between these two. Each external surface will allow incoming sound. Armed with values relevant to the particular design problem, the designer can ensure that the sound level which the façade allows into the rooms will provide a satisfactory listening environment for the occupants.

The insulation required may be estimated from the external noise level and the maximum background noise level. The external levels can be measured or, sometimes, using typical values as given in Table 2.11 as estimates. Current practice uses the measure L_{Aeq} (the average noise level) over a given period of time T , but because road traffic noise in the UK is still commonly measured in terms of L_{A10} (the level exceeded for 10% of the time), an approximate conversion is provided in the table. Desirable internal background noise levels for various room activities can be found in references or indeed may be part of the client's brief. Examples of maximum intrusive background noise levels are given in Table 2.12.

These tables give one value of sound level for each situation, whereas the figures for sound insulation for windows in Figures 2.54 and 2.55 are expressed as a series of values across the spectrum of frequencies. It is possible to describe all sound levels as values across the spectrum to give more information. However, here it is probably appropriate to simplify by using one sound level value as a composite of its spectrum. If more detail is required, expert advice should be sought.

Table 2.11 External noise levels (source BS 8233⁽⁵³⁾)

Situation	$L_{A10,18h}$	$L_{Aeq,18h}$
20 m from the edge of a busy motorway carrying many heavy vehicles, average speed 100 km/h; intervening ground grassed	80 dB	77 dB
20 m from a busy main road through a residential area, average speed 50 km/h; intervening ground paved	70 dB	67 dB
On a residential road parallel to a busy main road; screened by houses from the main road traffic	60 dB	57 dB

Table 2.12 Examples of recommended maximum intrusive background levels (source BS 8233⁽⁵³⁾)

Location	$L_{Aeq,T}$
Dwellings: bedrooms	30-40 dB
living rooms (steady intrusive noise)	40-45 dB
Offices: cellular	40-45 dB
open plan (acoustic privacy should also be considered for minimum levels)	45-50 dB
Libraries	45 dB
Law courts (up to 10 dB more may be acceptable in small courts)	30-35 dB

Table 2.13 Sound insulation of windows

Description	Sound insulation (average 100-3150 Hz)
Any type of window when open	Approx. 10 dB
Ventilated window, staggered openings not more than 5% of the area	Up to 15 dB
Ordinary single openable window closed but not weather-stripped, any glass	Up to 20 dB
Single fixed or openable weather-stripped (closed) window, with 4 mm glass	Up to 25 dB
Fixed single window with 10 mm glass	Up to 30 dB
Double openable window*, weatherstripped, 100 mm air space, one window of 4 mm glass, the other window at least 6 mm glass	Up to 35 dB
Double openable window*, weather-stripped, 150-200 mm air space, one window of 4 mm glass, the other window at least 6 mm glass	Up to 40 dB
Double window*, outer light fixed in resilient mounting, inner light fixed but removable, 200 mm or more air space, absorbent reveals, 6 mm and 10 mm glass	Up to 45 dB

*All double windows are taken as fitted in separate frames

Table 2.14 Effect of window size on the sound insulation of walls (source *BS 8233*⁽⁵³⁾)

Percentage of glazing	Single window (dB)	Double window* (dB)
100	20	40
75	21	41
50	23	43
33	25	44
25	26	45
10	30	47
Nil	Assumed sound insulation of the wall= 50 dB	

Note: if 10% or more of the wall is open window, the insulation will not be more than 10 dB

* i.e. two separate windows separated by an air space

Values for sound insulation of different window types are given in Table 2.13; this is consistent with Table 2.12. Windows and rooflights, however, do not usually form 100% of any particular external surface so it is necessary to find the effect of a window set in a wall on the total sound insulation. As mentioned above, the effect is not simply in proportion to the respective areas. Table 2.14 shows the effect of varying glazing areas of a single and a double window set in a notional wall of sound insulation value 50 dB.

It is seen from Table 2.14 that the range of 10-100% for percentage of glazing produces a range of variation of the insulation of 10 dB for single windows and 7 dB for double windows. The typical glazing range from 25-75% produces an insulation variation range of 5 dB for single windows and 4 dB for double windows. For example, a solid wall of insulation 50 dB with a double window in 10% of its area would have a resultant insulation value of 47 dB; for 75% window area it would be 41 dB.

Where a room has more than one external surface, each must be considered separately and the effects added logarithmically. In either case, there will be a figure for the total sound insulation provided by the external envelope.

2.4 Integration of daylight and electric light

The integration of daylight and electric lighting requires planning, the correct choice of light source and the controls to facilitate it. The advantages are a variable illuminance distribution, visual interest and lower energy consumption. Daylight in a building does not by itself lead to energy efficiency. Even a well daylit building may have high energy use if the lighting is left on because controls are inappropriate. Case studies⁽⁵⁴⁾ have shown that in a conventionally daylit commercial building the choice of control can make 30-40% difference to the resulting lighting use. Several publications⁽⁵⁴⁻⁵⁷⁾ give detailed guidance on this issue.

2.4.1 Overall control strategy

It is important that the choice of lighting control is appropriate for the type of activities in each area of the building, the access to daylight and the length of time for which each space is occupied. The first stage is to divide the space into light planning zones (see Figure 2.56) determined by the daylight distribution and use of each area⁽⁵⁷⁾. These zones can be:

- (a) owned spaces: small rooms for one or two people such as cellular offices

Figure 2.56 Schematic plan of an office showing control zones based on space usage

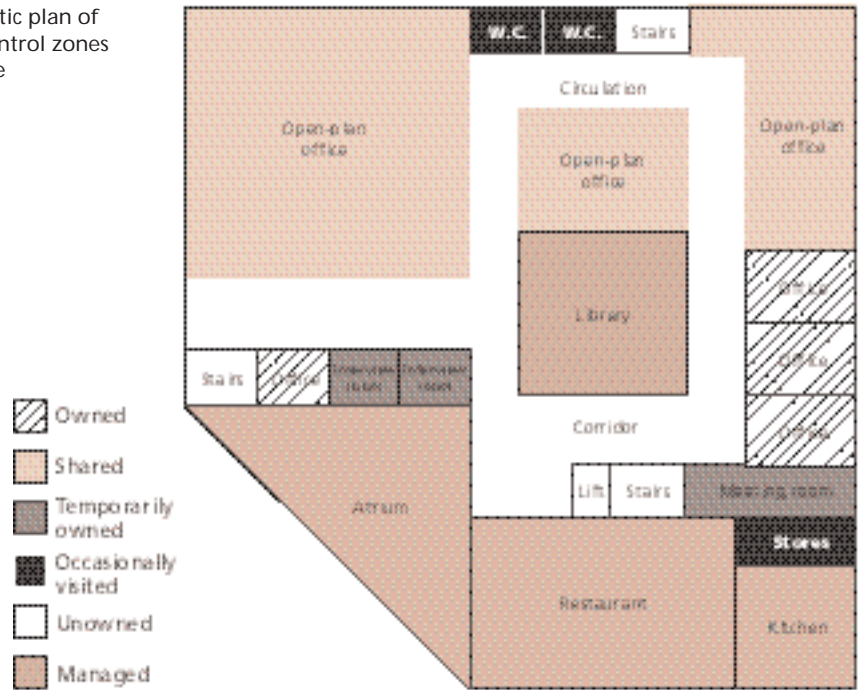

Table 2.15 Recommended types of lighting control

Space type	Daylit high occupancy	Daylit low occupancy	Non-daylit high occupancy	Non-daylit low occupancy
Owned	Manual by door** Flexible manual** Timed off, manual on** Photoelectric dimming*	Manual by door** Flexible manual** Timed off, manual on**	Manual by door** Flexible manual*	Manual by door** Flexible manual* Absence detection*
Shared	Flexible manual** Timed off, manual on** Photoelectric dimming**	Flexible manual** Timed off, manual on** Photoelectric dimming* Absence detection*	Flexible manual* Time switching*	Flexible manual** Absence detection*
Temporarily owned	Local manual** Flexible manual* Absence detection* Timed off, manual on* Photoelectric dimming*	Local manual** Absence detection** Flexible manual* Timed off, manual on* Key control*	Local manual** Absence detection*	Local manual** Absence detection** Flexible manual* Timed off, manual on* Key control*
Occasionally visited	Not applicable	Absence detection** Full occupancy linking* Local manual* Timed off, manual on* Key control*	Not applicable	Absence detection** Full occupancy linking* Local manual* Timed off, manual on* Key control*
Unowned	Photoelectric dimming** Photoelectric switching*	Full occupancy linking** Absence detection* Timed off, manual on* Photoelectric dimming* Photoelectric switching*	Time switching* Absence detection*	Full occupancy linking** Absence detection* Timed off, manual on*
Managed	Photoelectric dimming** Time switching** Centralised manual** Photoelectric switching* Programmed scene setting*	Photoelectric dimming** Time switching** Centralised manual** Photoelectric switching* Programmed scene setting* Full occupancy linking*	Centralised manual** Time switching** Programmed scene setting*	Centralised manual** Time switching** Programmed scene setting* Full occupancy linking*

** Recommended

* Assess for particular installation

- (b) shared spaces: multi-occupied areas such as open-plan offices and workshops
- (c) temporarily owned spaces: e.g. meeting rooms and hotel bedrooms, where people expect to operate the lighting controls while they are there
- (d) occasionally visited spaces: e.g. storerooms, bookstacks in libraries, aisles of warehouses and toilets
- (e) unowned spaces: e.g. circulation areas where people expect their way to be lit, but often do not expect to operate lighting controls
- (f) managed spaces: e.g. atria, concourses, entrance halls, restaurants, libraries and shops, where someone is in charge of the lighting, but usually too busy to control it. Individual users do not expect to control the lighting.

Table 2.15 suggests types of lighting control which may be appropriate for each particular space. The most effective option will depend on how much the space is occupied and whether it is effectively daylight. An area with daylight factors below 0.5% can be classified as non-daylit. Photoelectric switching is appropriate only for areas with daylight factors above 2%, unless design illuminances are low.

The Building Regulations Part L: Conservation of Fuel and Power (Part J in Scotland and Part F in Northern Ireland) contain a requirement for lighting control in new non-domestic buildings. This currently (1995 version) includes recommendations for localised control in office and warehouses, and either localised, photoelectric or timed control in other types of non-domestic buildings.

2.4.2 Switching or dimming control

Table 2.16 summarises the advantages and disadvantages of switched and dimming controls.

2.4.3 Light sources

The Building Regulations Part L: Conservation of Fuel and Power (Part J in Scotland and Part F in Northern Ireland) contain a requirement for energy-efficient light sources in new non-domestic buildings. Table 2.17 gives information on the main energy-efficient light sources currently available, their applications and advantages and disadvantages; further details are to be found in the *CIBSE Code for interior lighting*⁽²⁷⁾.

Table 2.16 Switching or dimming controls

Control	Advantages	Disadvantages
Switched	Cheap, wire wound ballasts can be used for fluorescent and compact fluorescent lamps and high pressure discharge sources	Changes in illuminance noticeable Frequent switching of light source will, in the main, shorten lamp life Energy savings limited High pressure discharge sources require warm-up period, restrike period 15 mins
Dimmed	Suitable high frequency ballasts can be used Analogue ballasts produce stepped dimming. If steps too large, change can be noticeable. Digital ballasts produce smooth dimming Task illuminance can be set and maintained Energy savings maximised Circuits have soft start, increasing lamp life Can be less obtrusive to occupants	More expensive than switched High pressure discharge sources are not usually dimmable

Table 2.17 Energy-efficient light sources

Type of source	Application	Advantages	Disadvantages
Tungsten and tungsten halogen	Might be used as part of a task-ambient design, either as a local task light or as an auxiliary lamp in a high pressure discharge luminaire	Cheap to buy Dimmable Instant light Excellent colour rendering	Inefficient Short life
Linear fluorescent	Can be used in ceiling mounted, surface or suspended luminaires: as part of a direct, localised or task-ambient installation	Cheap to buy Dimmable with special ballasts Instant light Energy efficient Long life (12 000-15 000 hrs) Good colour rendering for triphosphor types	Linear luminaires or concealed lighting must be used
Compact fluorescent	Can be used in ceiling mounted, surface or suspended luminaires: as part of a direct, localised or task-ambient installation. Larger lamp wattages can be used as uplighters	Cheap to buy Instant light Energy efficient Long life (10 000 hrs) Good colour rendering Small sizes available	Dimming can be difficult although some dimming ballasts are now available
High pressure discharge			
Metal halide	Most commonly used in an uplighter as part of a task-ambient installation. They are point sources that are very bright when viewed directly	'White' light source Energy efficient Good colour rendering Small size Relatively long life	Expensive Requires warm-up period after switch on, restrike period up to 15 mins after switch off Not dimmable Older types not colour stable
Mercury vapour	As for metal halide	Relatively cheap Long life	Poor colour rendering Average efficiency Warm-up and restrike period required
Sodium	As for metal halide	High efficiency Long life except 'white' SON	Poor colour rendering except 'white' SON and SON deluxe which are average Warm-up and restrike period (around 30 seconds) required

2.4.4 Control hardware Once the most appropriate control strategy has been established for each space (Table 2.15), the next stage is the detailed design of the control system.

2.4.4.1 Photoelectric (daylight linking) When planning photoelectric control, determine the effect of windows on daylight distribution. Electric lighting should be zoned to match the planning module, spacing/mounting height of luminaires and daylight distribution. Areas with different daylight illuminances should be controlled separately.

The likely energy savings from photoelectric control can be estimated in the following way.

Table 2.18 Orientation factors for photoelectric control⁽⁶⁰⁾

Orientation	Factor
North	0.97
East	1.15
South	1.55
West	1.21
Horizontal	1.00

First, the external horizontal illuminance is established. Figure 2.57 gives daylight data from the sky alone for London and Edinburgh. These are presented as cumulative distributions of external horizontal illuminances (the percentage of year a given illuminance is exceeded). BRE Report BR21⁽⁵⁸⁾ gives more detailed data for the UK and the *European daylighting atlas*⁽⁵⁹⁾ gives calculated data for a range of locations within the European Union. From these data, internal daylight illuminances are found by multiplying the external horizontal illuminances by the daylight factor (see section 3.2) at the point indoors and by an orientation factor. The orientation factors given in Table 2.18 allows for the different amounts of skylight windows facing in different directions will receive⁽⁶⁰⁾.

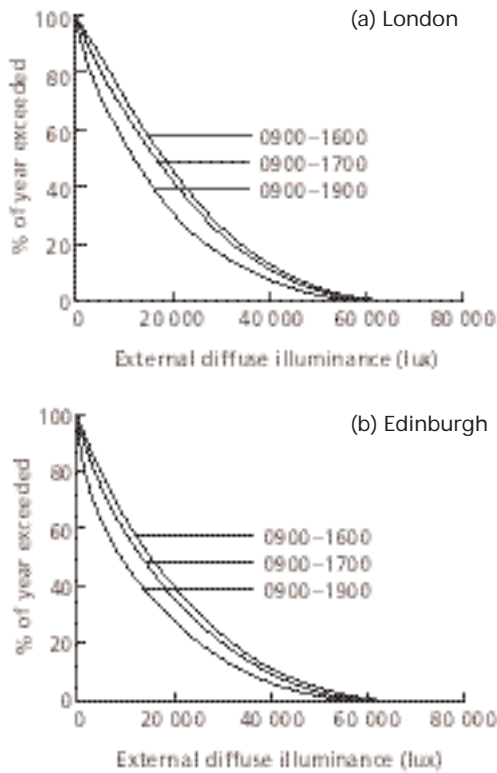

Figure 2.57 Percentage of working year a given external horizontal diffuse illuminance is exceeded in (a) London and (b) Edinburgh

The simple on/off control switches off lights when a daylight illuminance E_s is reached at the control point, and switches them on when the daylight illuminance drops below E_s . The fraction of time the lights will be off is given by the fraction of the year E_s is exceeded. To get this fraction we calculate the external illuminance E_{out} which corresponds to E_s . This is given by

$$E_{out} = 100 E_s / (f_o df_{min}) \text{ lux} \tag{2.7}$$

where f_o is the orientation factor (Table 2.18) and df_{min} is the daylight factor (in %) at the worst lit point in the switched zone. The savings are equal to the fraction of year E_{out} is exceeded (see Figure 2.57).

Figure 2.58 shows the energy savings for high frequency photoelectric dimming control. Lynes and Littlefair⁽⁶¹⁾ give a method to estimate savings in interiors lit from one side where the location of luminaires and control points has yet to be decided.

In planning photoelectric control, the designer needs to determine whether blinds or louvres will be used for controlling glare, or where a maximum illuminance might be part of the design criteria e.g. in a picture gallery. This can affect the location of the illuminance sensor.

- (a) Roof-mounted sensors need to be protected from direct sunlight and must be cleaned regularly. They can be orientated for each façade of the building, and should be software-driven to account for changing use of blinds/louvres at windows.
- (b) Ceiling-mounted sensors can be calibrated to read the illuminance at a point in the interior and thus will automatically respond to the change of illuminance brought about by changing daylight conditions and the use of blinds. They are suitable for open plan areas and blinds/louvres that operate in unison for a particular elevation. For best results, ceiling-mounted sensors should be screened from external light coming directly from the windows. Cellular offices need individual sensors. These can also be linked to presence detectors to provide zonal control with occupancy sensing.
- (c) Luminaire sensors are of two types, clip-on or integrated. The former are simple illuminance sensors and can be set up to maintain a level using high frequency dimmable ballasts. The latter are more sophisticated and can incorporate presence detectors. These control individual luminaires and can be linked more closely to individual circumstances and personal requirements.

For photoelectric switching, some form of control technique is required to avoid frequent switching during partly cloudy days. If occupants can control the lighting (for example in offices) a manual on switch is best. If automatic switching on is chosen, a daylight linked time delay gives the

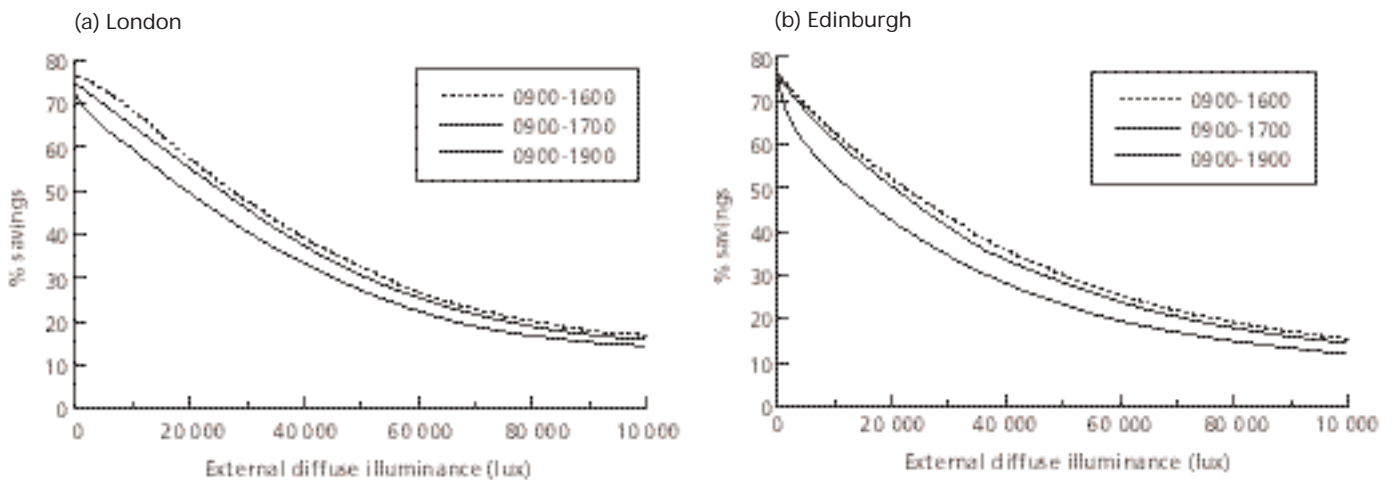

Figure 2.58 Energy savings from high frequency dimming for (a) London and (b) Edinburgh

best savings for a given number of switching operations. This involves not switching the lighting off until daylight has exceeded the target level for a preset interval. An alternative is differential switching where switching off occurs at a different, higher illuminance than switching on. This ensures that switching off is less noticeable.

2.4.4.2 Manual switching

The use of manual switching should be considered. For conventional manual switching, the energy use can be estimated using Figure 2.59⁽⁶²⁾. Start by deciding on the probable occupancy of the room and, in particular, the times when the first person enters the room and the last person leaves. From the minimum daylight factor (see section 3) in the room, find the probability that the first person will switch on the lights (see Figure 2.59). Then calculate the hours of lighting used by assuming that the lights will be left on or off until the last person leaves.

For example, consider an office with a 1% minimum daylight factor, occupied from 0800-1800. The switching probability at 0800 is 60%. So on 60% of days the lighting will be switched on, and then left on all day.

Table 2.19 Orientation factors for manual switching

Orientation	Factor
North	0.77
East	1.04
South	1.20
West	1.00

Secker and Littlefair⁽⁶³⁾ give switching probability curves for a range of UK locations. Table 2.19 gives the orientation factors to correct the minimum daylight factors for Figure 2.59; they are different from those in Table 2.18 to ensure self-consistency with the original measurements. Section 3 explains how to calculate minimum daylight factors. Where window shape and position are uncertain, estimate the minimum daylight factor by dividing the average daylight factor by 2.3.

Various factors can affect manual switching that the correlations above do not allow for. If the lighting buzzes, flickers or causes glare, people will want to switch it on less. The type of task is another factor; display screen equipment users, for example, may require less lighting. Preadaptation, for example before entering a room from a bright atrium or gloomy corridor, may also influence switching⁽⁶⁴⁾.

As people are generally not good at switching lighting off when it is not needed, a timed switch off should be considered. In the UK this type of switching arrangement is now quite common and significant energy savings have been recorded⁽⁶⁴⁾. The timed off works best in reasonably daylighted areas otherwise switching back on may become a habit. It is best not to have too many switch offs as these can be distracting; the middle and end of the working day is usually sufficient. It is also best to arrange

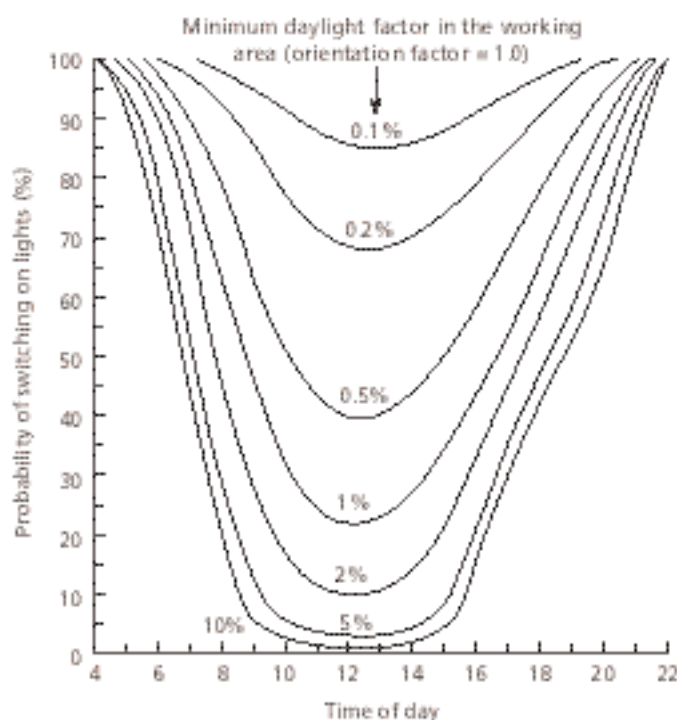

Figure 2.59 Switch-on probabilities for the whole year, for Kew

(a) occupied



(b) unoccupied



Figure 2.60 Occupancy sensing in a warehouse: (a) aisle occupied and (b) aisle unoccupied

switching off at a natural break such as lunchtime when most people may be out of the room. This assumes a fixed timetable exists; in offices, for example, flexible working patterns may make it difficult to set times for switching off.

In larger spaces with a central manual switch panel, waste can occur if some areas of the room are well daylight and others are not, or if some working areas are unoccupied. Localised switching is of benefit here. This can involve individual pull cords on the light fitting or switching via the building telephone system where occupants key in a code on their telephones to switch the lighting on or off. Compared with conventional switching, telephone switching can reduce wiring costs and allow flexible partitioning of open plan areas.

Infrared switches operated by transmitter can also be used. The transmitters can be personal, portable or wall-mounted. A further dimension in individual control is the localised manual dimming system (typically using an infrared controller). These are now available and are especially valued in interiors with display screen equipment.

2.4.4.3 *Occupancy sensing*

Occupancy sensing is not specifically daylight linked, but can give significant extra savings in intermittently occupied areas. Full occupancy sensing with presence detection is particularly useful in spaces such as warehouses (see Figure 2.60) where people are carrying things, driving vehicles or wearing protective clothing. It is also appropriate where people do not expect to control the lighting themselves, for example in corridors. In owned, shared or temporarily owned spaces (see section 2.4.1), absence detection is often better: the occupancy sensor only switches the lighting off, with switching on being done manually.

2.4.4.4 *Case study: flexible manual control*

The refurbishment of Black Horse House, a central London office building, has included a flexible manual switching system. This involves

- Infrared switching: each occupant has his or her own controller and there are also wall-mounted switches. The wall switches are battery operated and no hard wiring was necessary.

- A timed switch off at midday: occupants can choose to switch the lighting back on, but rarely do so if daylight levels are sufficient. There are also timed switch offs at the end of the working day.

As it needed less wiring, the system cost no more than conventional manual switching but still gives considerable energy savings. These were measured to be 32% of the previous lighting use. An additional bonus of the infrared control is greater flexibility if internal partitions need moving.

2.4.5 Installation

Wiring systems need to be planned to allow for the control zones if hard wired installations are to be used. Some control systems employ a bus wire to transport information to individual receivers mounted in each luminaire or group of luminaires. For photoelectric controls, in situ sensor calibration is required. For flexible manual controls, and systems with an override, the occupants need to know how to operate the lighting control. Periodically, the operation of the controls should be reviewed to check everything is working properly⁽⁶⁵⁾.

3 Daylight calculations

3.1 Introduction

Daylight is constantly changing, so its level at a point in a building is usually defined as a daylight factor. This is the ratio of the indoor illuminance at the point in question to the outdoor unobstructed horizontal illuminance. Both illuminances are measured under the same standard sky, usually a CIE overcast sky. By definition, direct sunlight is excluded.

Daylight is required for two separate purposes: to give a light airy appearance to a space and to provide enough light for specific tasks⁽¹⁰⁾. To assess the overall daylight appearance of a room under cloudy conditions, use the average daylight factor; section 2.2.2 explains how to calculate this.

The average daylight factor gives a measure of the overall level of light in the room. However the distribution of light is also important. Even if the average daylight factor is high, parts of the room may look gloomy if they cannot receive direct light or the room is too deep. Section 2.1.2 explains how to plot the no-sky line, giving the areas of the room that cannot receive direct skylight. It also provides a formula to calculate whether a room is too deep for satisfactorily uniform daylighting.

Occasionally, the detailed distribution of daylight factors in an interior is required or energy-use calculations for lighting may call for the minimum daylight factor at the worst lit workstation. Daylight factors and task illuminances at particular points in the interior can be found using a manual method (see section 3.2), computer program (see section 3.3) or scale model (see section 3.4)

For specialist applications certain ways of calculating daylight are used. Rights to light calculations^(2, 12, 13) use the sky factor which is similar to the daylight factor except that it excludes reflected light and the effects of glazing, and it is calculated under a uniform sky.

3.1.1 CIE skies

3.1.1.1 Overcast sky

Many daylighting calculations are based on the CIE overcast sky. This represents the luminance distribution of the sky under heavily overcast conditions. It is symmetrical in azimuth and its luminance L increases with altitude γ in the sky according to the formula:

$$L\gamma = L_z(1 + 2 \sin \gamma)/3 \quad (3.1)$$

The horizon luminance is, therefore, only a third that of L_z , the zenith luminance.

Real skies vary a lot in their luminance, or brightness distribution. But in general, for non-overcast conditions⁽⁶⁰⁾:

- the horizon will be brighter than the CIE overcast sky predicts; so more light will be received in sidelit rooms
- the area of sky near the sun will be brighter; over an average day, a south-facing room will receive more light than a north-facing one.

The orientation factors in Table 2.18 can be used to take account of both these effects.

3.1.1.2 Clear sky

The CIE also defines a clear sky⁽⁶⁶⁾ for completely cloudless conditions. This sky is much brighter near to the sun. In contrast to the overcast sky, its horizon is brighter than its zenith, so more light will be received in sidelit rooms. In polluted and relatively humid climates, the clear sky is an important source of light. In hot dry climates, the clear sky is a darker blue, and the main sources of light (apart from the sun itself) are often the ground and adjacent buildings.

3.2 Manual calculations

The daylight factor at a point is calculated by first determining its three components — the sky component SC, the externally reflected component ERC and the internally reflected component IRC — and then adding the three values.

The SC and ERC can be determined by any one of several methods, such as the BRE daylight protractors which are applied to scale plan and section drawings⁽⁶⁷⁾. The most commonly used method for determining the IRC is based on the BRE split-flux formula.

3.2.1 Sky component

Table 3.1 provides the BRE simplified method for estimating the sky component (SC) at points in rooms lit by vertical windows. It relates only to the CIE standard overcast sky.

The following information (see Figure 3.1) is needed to use the table:

- h_w , the effective height of the window head above the working plane after allowing for any obstructions
- H_{wp} , height of working plane above floor
- W_1 , W_2 , the effective widths of the window on each side of a line drawn from the reference point normal to the plane of the window, taken separately
- D_1 , the distance from the reference point to the plane of the window (this is the plane of the inside or the outside of the wall, whichever edge of the window aperture limits the view of the sky).

The ratios h_w/D_1 , W_1/D_1 and W_2/D_1 are worked out and the SC can then be read directly from the table. In general, the SC at any other reference

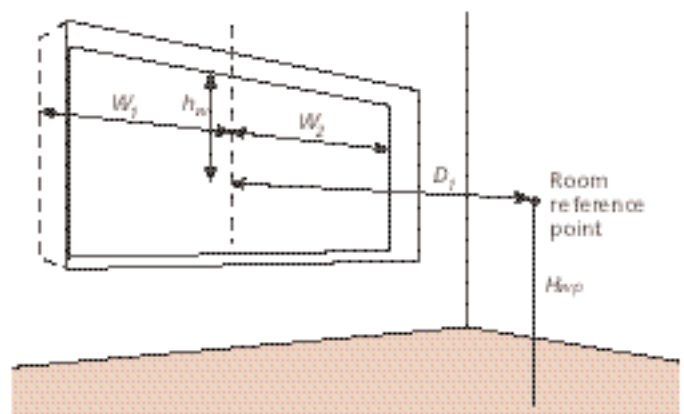

Figure 3.1 Dimensions used in the simplified daylight table (Table 3.1)

Table 3.1 Sky components (CIE overcast sky) for vertical unglazed rectangular windows

h_w/D_f	W/D_f														
	0.1	0.2	0.3	0.4	0.5	0.6	0.8	1.0	1.2	1.4	1.6	2.0	3.0	4.0	∞
∞	1.6	3.1	4.6	6.1	7.4	8.6	10.5	12.0	13.4	14.5	15.4	16.3	17.8	18.3	18.8
4.0	1.5	3.0	4.5	5.9	7.3	8.4	10.3	11.5	12.9	13.6	14.3	15.5	16.6	16.9	17.1
3.0	1.5	2.9	4.4	5.6	6.9	8.0	9.8	10.9	12.3	12.6	13.4	14.6	15.5	15.6	15.9
2.0	1.3	2.5	3.9	5.0	6.0	7.0	8.4	9.4	10.4	10.9	11.4	12.1	12.5	12.6	12.8
1.8	1.2	2.4	3.6	4.8	5.8	6.6	7.9	8.9	9.8	10.3	10.6	11.3	11.6	11.8	11.9
1.6	1.1	2.3	3.4	4.4	4.9	6.1	7.3	8.1	9.0	9.4	9.8	10.3	10.6	10.8	10.8
1.4	1.0	2.0	3.0	4.0	4.8	5.5	6.5	7.4	8.0	8.4	8.8	9.1	9.4	9.4	9.5
1.2	0.9	1.8	2.6	3.4	4.1	4.8	5.6	6.3	6.8	7.1	7.4	7.6	7.8	7.9	7.9
1.0	0.7	1.4	2.1	2.8	3.3	3.8	4.5	5.0	5.4	5.6	5.8	5.9	6.0	6.1	6.3
0.9	0.6	1.2	1.9	2.4	2.8	3.3	3.9	4.3	4.6	4.8	4.9	5.0	5.1	5.1	5.2
0.8	0.5	1.0	1.5	2.0	2.4	2.8	3.3	3.6	3.9	4.0	4.1	4.1	4.3	4.3	4.3
0.7	0.4	0.9	1.2	1.6	1.9	2.1	2.6	2.9	3.1	3.1	3.3	3.3	3.4	3.4	3.5
0.6	0.3	0.7	0.9	1.2	1.5	1.7	2.0	2.3	2.4	2.4	2.5	2.5	2.6	2.6	2.6
0.5	0.2	0.5	0.6	0.9	1.0	1.2	1.4	1.7	1.8	1.8	1.8	1.9	1.9	1.9	1.9
0.4	0.1	0.4	0.4	0.6	0.7	0.8	1.0	1.1	1.2	1.2	1.2	1.2	1.2	1.2	1.2
0.3	0.1	0.2	0.2	0.3	0.4	0.4	0.6	0.6	0.6	0.6	0.6	0.6	0.7	0.7	0.7
0.2	0.0	0.1	0.1	0.1	0.2	0.2	0.3	0.3	0.3	0.3	0.3	0.3	0.3	0.3	0.3
0.1	0.0	0.0	0.02	0.0	0.0	0.1	0.1	0.1	0.1	0.1	0.1	0.1	0.1	0.1	0.1

point can be obtained by addition or subtraction. If the windowsill is above the working plane, the scs blocked by the wall below the sill are calculated in the same way and subtracted.

3.2.2 Externally reflected component

The externally reflected component (ERC) can be estimated by calculating the 'equivalent SC' obscured by the obstruction as seen through the window and dividing this by 5.

3.2.3 Internally reflected component

The average internally reflected component (IRC) may be calculated directly from the BRE split-flux inter-reflection formula for vertical windows, as described in BRE Digest No 310 *Estimating daylight in buildings: part 2* ⁽⁶⁷⁾.

$$\text{IRC} = \frac{TA_w}{A(1-R)} (CR_{fw} + 5R_{cw}) \quad (3.2)$$

where T is the glass transmittance, A_w is the window area, A is the total area of ceiling, floors and walls including window area, R is the average reflectance of ceiling, floor and all walls, including window, expressed as a fraction, C is approximately given by $\theta/2-5$ where θ (see section 2.1.4) is the angle of visible sky in degrees, measured from the centre of the window, R_{fw} is average reflectance of the floor and parts of the walls below the mid-height of the window (excluding the window wall) and R_{cw} is the average reflectance of the ceiling and parts of the walls above the mid-height of the window (excluding the window wall).

The split-flux method produces an averaged scalar IRC, which will be equal to the average value over the whole room surfaces. There is some variation of the IRC over the working plane and this may be expressed by the formula:

$$\text{IRC} = [(a-1) \times (\text{SC} + \text{ERC})] + [v \times e \times A_w/A_f] \% \quad (3.3)$$

where a is given by Table 3.2, v is given by Table 3.3, $e = (\theta-10)/80$ where θ is the angle of the visible sky measured from the centre of the window and A_w/A_f is the ratio of the window area to floor area ⁽⁶⁸⁾.

Table 3.2 Coefficient a for the internally reflected component

Floor reflection factor	0.3			0.1							
Ceiling reflection factor	0.7			0.7			0.5			0.3	
Wall reflection factor	0.5	0.3	0.1	0.5	0.3	0.1	0.5	0.3	0.1	0.3	0.1
Room index	Values of a										
1.0	1.1	1.1	1.0	1.0	1.0	1.0	0.9	0.9	0.9	0.9	0.9
1.25	1.1	1.1	1.1	1.1	1.0	1.0	1.0	1.0	1.0	1.0	1.0
1.5	1.2	1.1	1.1	1.2	1.1	1.1	1.1	1.1	1.0	1.0	1.0
2.0	1.2	1.2	1.1	1.2	1.1	1.1	1.1	1.1	1.0	1.0	1.0
2.5	1.3	1.2	1.2	1.3	1.1	1.1	1.2	1.1	1.0	1.0	1.0
3.0	1.5	1.4	1.3	1.4	1.2	1.1	1.3	1.2	1.1	1.1	1.0
4.0	1.7	1.6	1.4	1.5	1.3	1.2	1.4	1.3	1.2	1.1	1.0
5.0	2.0	1.8	1.6	1.7	1.4	1.3	1.5	1.4	1.3	1.1	1.0

Table 3.3 Coefficient v for the internally reflected component

Floor reflection factor	0.3			0.1							
Ceiling reflection factor	0.7			0.7			0.5			0.3	
Wall reflection factor	0.5	0.3	0.1	0.5	0.3	0.1	0.5	0.3	0.1	0.3	0.1
Room index	Values of v										
1.0	4.0	2.9	2.1	3.5	2.2	1.6	3.1	2.0	1.3	1.7	1.0
1.25	3.9	2.6	2.0	3.1	2.0	1.6	2.7	1.8	1.3	1.6	0.9
1.5	3.8	2.3	1.8	2.7	1.8	1.4	2.5	1.6	1.1	1.3	0.8
2.0	3.5	2.2	1.7	2.5	1.7	1.4	2.1	1.4	1.0	1.1	0.8
2.5	3.2	2.0	1.6	2.3	1.6	1.3	1.8	1.3	0.9	1.0	0.6
3.0	2.7	1.7	1.3	2.1	1.4	1.1	1.6	1.1	0.9	1.0	0.6
4.0	2.5	1.6	1.1	1.8	1.3	1.0	1.3	1.0	0.8	0.9	0.5
5.0	2.1	1.3	1.0	1.6	1.1	0.9	1.0	0.9	0.6	0.8	0.4

Appropriate corrections should be made for maintenance, glazing bars and glazing transmission. In the tables, the room index is given by:

$$\text{Room index} = \frac{L \times W}{H_r(L + W)} \quad (3.4)$$

Where L is room depth, W is room width and H_r is room height above working plane.

3.2.4 Correction factors

In practice, the daylight factor calculated by adding the SC, ERC and IRC should be corrected as appropriate for the following:

- Glass transmission: the diffuse transmission is normally used (see appendix A1.1).
- Window frame and glazing bars: where calculations have been based on the overall window aperture an allowance must be made for the reduction due to window frames and glazing bars. Alternatively, use a correction factor of 0.85 for metal frames and 0.75 for timber frames.
- Dirt on glass: the reduction in light transmission of glazing due to dirt depends on the slope of the glazing and the degree of atmospheric pollution. Appendix A1.2 gives more details.

Figure 3.2 The radiosity method: each surface is divided into elements which reflect light

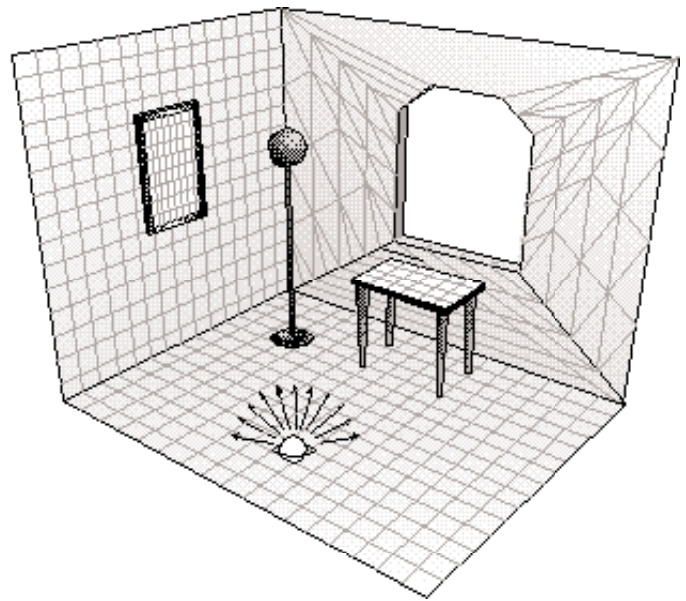

3.3 Computer methods

Traditional methods of daylight calculation use the standard overcast sky as a starting point. Computer calculations can, in principle, go much further because they allow for the effects of window orientation, clear skies or direct sunlight. Most sophisticated programs can allow for the clear sky and sometimes the average sky⁽⁶⁹⁾. This includes direct sunlight as well as a sky luminance distribution averaged over all the different weather conditions, and is especially suitable for calculating the effects of innovative daylighting systems. Using the average sky as a starting point, the time-averaged illuminance at a point inside a building can be calculated for any time of day and year.

A key issue in computation is the calculation of internally reflected light. Simple techniques such as the BRE split-flux formula (see section 3.2) assume this is uniform, but it does vary. Computer models are available which can predict these variations in internally reflected light. These can be divided into two types: radiosity and ray-tracing.

Both methods can deal with complex geometry, allow complex sky distributions and potentially produce photorealistic images. Radiosity methods assume all surfaces are perfectly diffusing, otherwise computational times would be excessive. Hence the advantage of ray-tracing techniques in accuracy and image rendering. However, radiosity has its advantages. Computational times are normally shorter and walk-throughs of models and animations are possible because the luminances of the surfaces are independent of the viewing position.

- (a) The radiosity method (see Figure 3.2) involves dividing the room surfaces into a large number of elements. Reflections between each element and every other element that can receive light from it are then modelled. The number of calculations is equal to the square of the number of elements chosen. The computation time should be considered when deciding on the subdivision of the surfaces.

Complex models can take a prohibitive amount of memory, while curved surfaces are not easily supported. Transparency effects cannot be simulated easily. Specular reflectance can theoretically be simulated but is impractical given the amount of computer memory required.

Progressive radiosity starts with a rough estimate of surface luminances then refines it. That means that an initial picture can be displayed very fast. The procedure can be stopped as soon as sufficient refinement has been achieved.

Figure 3.3 Schematic diagram showing the ray-tracing method

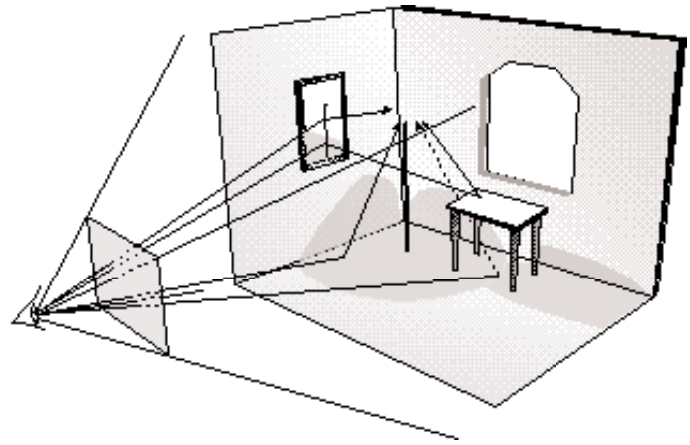

(b) There are two ray-tracing (see Figure 3.3) techniques:

- Backward ray-tracing in which a ray is traced back from the eye position until it intersects with a surface. In basic ray-tracing, after the intersection with a surface a ray is traced from the intersection point to light sources. If the surface is specular or transparent the ray follows the geometry of that reflection or transmission to the next surface before it is traced to the light sources. If the ray is not obscured by another surface or objects, the light reaching the intersection point from the sources is calculated. The ray-tracing process is repeated until the number of rays specified is reached. In this basic ray-tracing, diffuse inter-reflections within the space are ignored and an ambient value akin to the internally reflected component is added to the value at each pixel point on the screen. This leads to a degree of inaccuracy. More sophisticated programs overcome this problem when a ray intersects a surface by emitting a number of rays from the intersection point. The processing time increases considerably with the number of bounces and these must be limited.
- Forward ray-tracing in which the rays are traced from the light source to eye position. This method is better than backward ray-tracing for spaces equipped with light pipes, eggcrates and generally innovative mirrored daylighting systems. It generally suits smaller sources.

Ray-tracing techniques in general can easily handle complicated geometries and are capable of accurately rendering shadows, specular reflection and transparency effects while maintaining efficient use of memory. The pictures rendered are view dependent, however, and if the viewer's position changes the whole process has to be repeated.

3.4 Scale model studies

3.4.1 Artificial skies

Artificial skies (see Figure 3.4) can be designed to simulate all types of sky. The most commonly used are the rectangular mirrored type or a hemispherical dome, which are both designed to simulate a CIE overcast sky. The main disadvantage of the former is the multiple reflections of the model in the mirrors while the latter can suffer from parallax errors if the model is too large in relation to the sky. For a mirror-type sky the model should not be greater than 30-40% of the sky dimensions for a rooflit model and less (20%) for models glazed on two opposite sides. The dome models should generally be smaller. The dome sky offers more flexibility in that it can be adapted with a low reflectance (< 50%) to simulate other types of sky⁽⁷⁰⁾. However there can be a problem with dome skies because light may be directed upwards into the room from the horizon of the dome. This can be counteracted, at the cost of some lost light, by placing

Figure 3.4 Artificial skies
(a) Rectangular (mirror type)
and (b) hemispherical

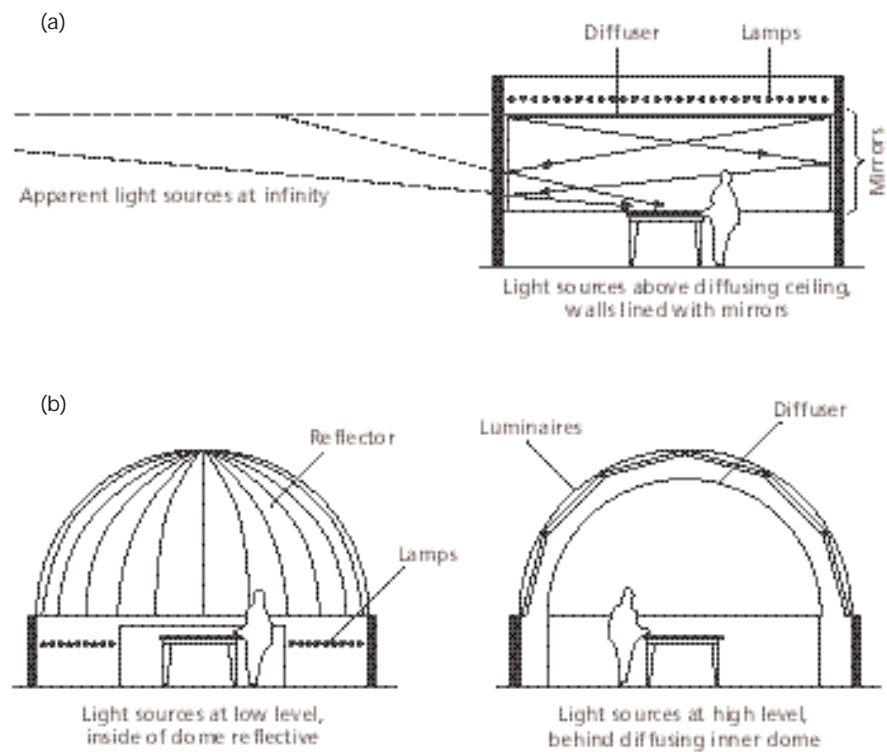

the window head level with the horizon of the dome. Two recently constructed UK skies use dimmable multiple lamps to simulate a variety of sky conditions, together with an artificial sun.

3.4.2 Guidelines

When using scale models the following guidelines should be followed:

- The model should be as large as possible within the constraints of the sky. Façade wall thicknesses, any splaying etc should be modelled if possible.
- The model should be light-tight, which normally means using tape and opaque materials.
- The reflectivities of the surfaces should be modelled accurately. There is a tendency to use all white surfaces, which can lead to a large overestimation of available light.
- External obstructions should be modelled accurately in both size and reflectance, which is often quite difficult because of their distance from the building being studied.
- The scale of the model needs to take into account the dimensions of the photocells being used. Typically, 1:10 to 1:40 is a reasonable range of scales. Measurements are usually made on the working plane (0.85 m for domestic buildings, 0.7 m for offices) and while the photocell can be lifted upwards it is more difficult to sink it into the model. For measurements on vertical surfaces it is easier to sink the photocells into the walls.
- Photographs may be taken of the spaces within the model using a SLR camera with a 28-mm lens. Accurately cut a hole the size of the lens and replace the cut disc after use, sealing with tape. Filters will be required to obtain a correct colour balance.
- Models are usually unglazed and then corrected for glazing type, glazing bars and dirt. Diffusing materials can be modelled but their transmittance must be estimated and it is usual to model the clear glazing and diffusing glazing separately (closing the appropriate openings with low reflectance surfaces) and add the results. This procedure is commonly used if different transmission glasses are used. Care must be taken if the angle of light striking

the glazing is predominately at a low angle to the glazing. Under these conditions much of the light is reflected and it is better to incorporate the glazing material.

- Appropriate colour and cosine corrected photocells should be used, with a linear response.

3.4.3 Sunlight studies

Sunlight studies using a model can provide valuable information for spacing of buildings, the design of shading devices and choosing building form or orientation. A suitable light source and sundial are required. An east-west sundial (see Figure 3.5) contains two scales back-to-back. One faces east, the other west. Paste east and west faces back-to-back on a circle of stiff card 100 mm in diameter, making sure that the latitude scales on the circumference coincide. Mount the assembly on the folded support, with the east and west sides facing as indicated in Figure 3.6.

The circumference of the sundial is marked out in degrees of latitude. Revolve the sundial circle in its stirrup until your geographical latitude (e.g. London 51.5°N) points straight downward and coincides with the east-west baseline on the support. Place a gnomon (a shadow-casting stick) at the centre of each face of the sundial. Each gnomon should

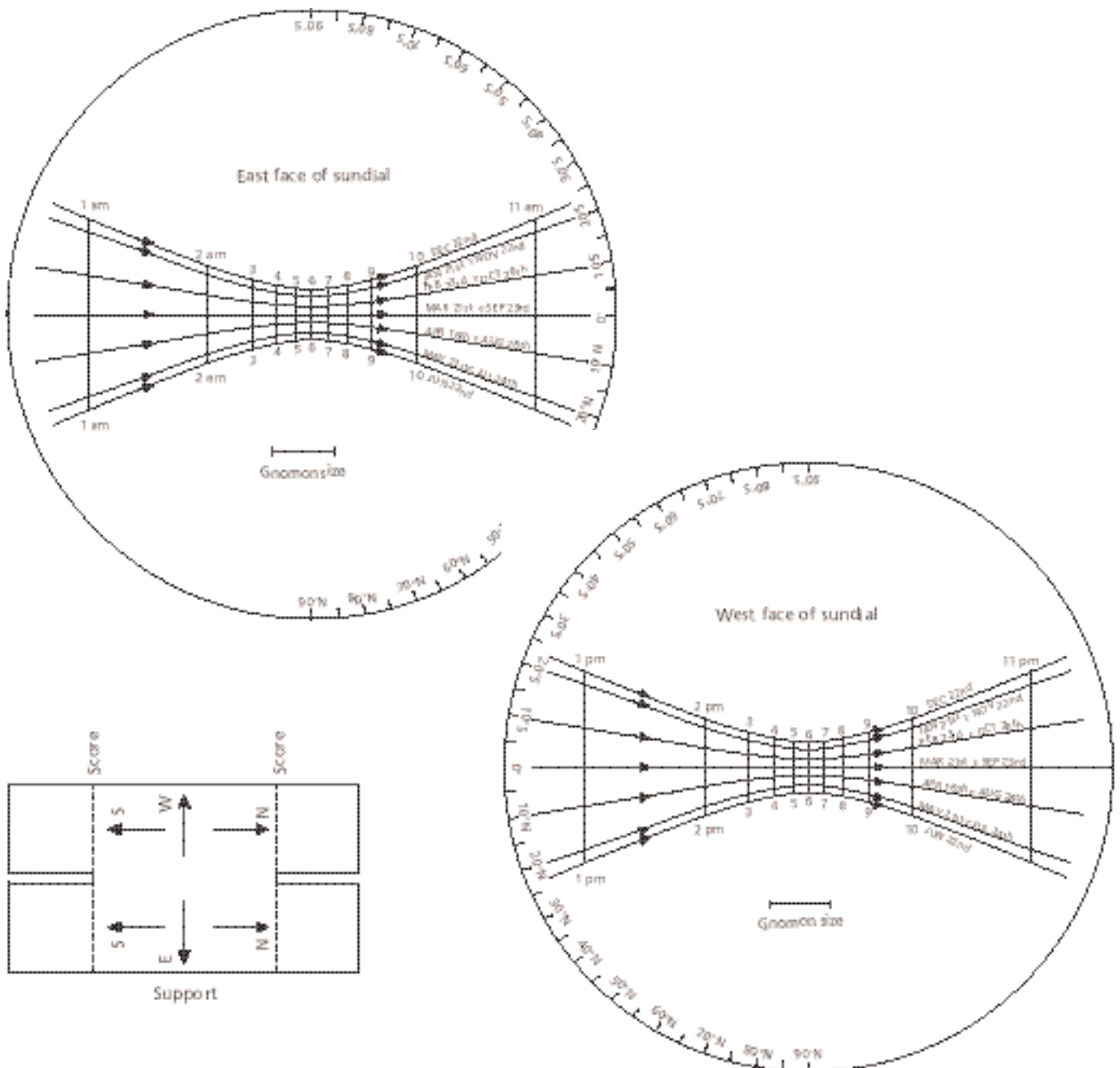
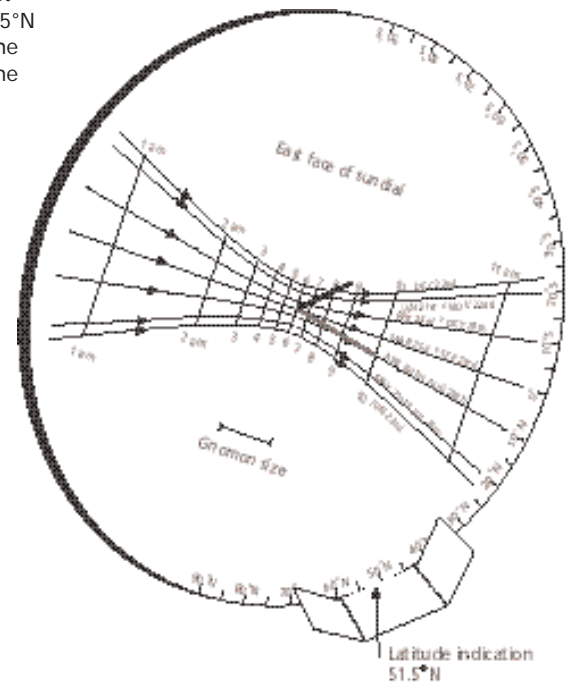

Figure 3.5 East and west faces and support of sundial, 100 mm diameter; length of gnomon 10 mm

Figure 3.6 East face of east-west sundial at latitude 51.5°N (London). The shadow of the gnomon shows that the time is 10 am in April or August



project 10 mm on each side of the sundial scale.

On a sunny day the shadow of the tip of the gnomon will indicate the time of day (in relation to solar noon when the sun crosses the north-south meridian). During the course of a day the shadow of the tip of the gnomon will trace a path across the sundial scale corresponding to the time of year. These sunpaths are labelled at monthly intervals between the summer and winter solstices.

The most obvious limitation of the east-west sundial lies in the fact that within 50 minutes of noon and midnight the shadow of the gnomon is cast off the scale. Fortunately the direction of the sun at noon, and hence the shadow of the gnomon at noon, are quite easy to establish. The sun will be in the plane of the circular sundial. Each face will be in equal semi-shadow. The direction of the infinitely long shadow will coincide, on the latitude scale, with the solar declination (see Table 3.4).

Place the east-west sundial close to an architectural model, as in Figure 3.7. Orientate it correctly with respect to the model. Use a pearl household lamp to project the shadow of the tip of the gnomon onto a chosen time/date mark on the indicator. Use the east-facing sundial for the morning, the west-facing one for the afternoon. The appropriate shadows will be cast on the model, and can be photographed.

This is a task for three people. One (the tallest!) holds the lamp as far away as possible, to ensure that the incident rays of 'sunlight' are effectively parallel. One watches the sundial, telling the lamp-bearer to move up, down, left or right. The third person photographs the model (from the north, in the northern hemisphere), remembering to include in each photo a label showing the time and date. The distance of the 'sun' from the model must be as large as possible to ensure that incident rays are all parallel.

In principle, the real sun is the ideal source for model studies. Its rays are parallel and the angular subtense is correct, so shadows should have just the right sharpness and density. Unfortunately, the sun is not always available when needed. If the real sun is used, the base of the sundial should be fixed securely in the plane of the model. The model should be mounted on a suitable platform, such as a drawing board on castors, and

Table 3.4 Solar declinations

Date	Declination
Jun 22	23°27' N (summer solstice)
May 21/Jul 24	20°N
Apr 16/Aug 28	10°N
Mar 21/Sep 23	0° (equinox)
Feb 23/Oct 20	10°S
Jan 21/Nov 22	20°S
Dec 22	23°27' S (winter solstice)

Figure 3.7 Model alongside east-west sundial at latitude 51.5°N. The shadow of the gnomon shows that the time is 9 am in May or July

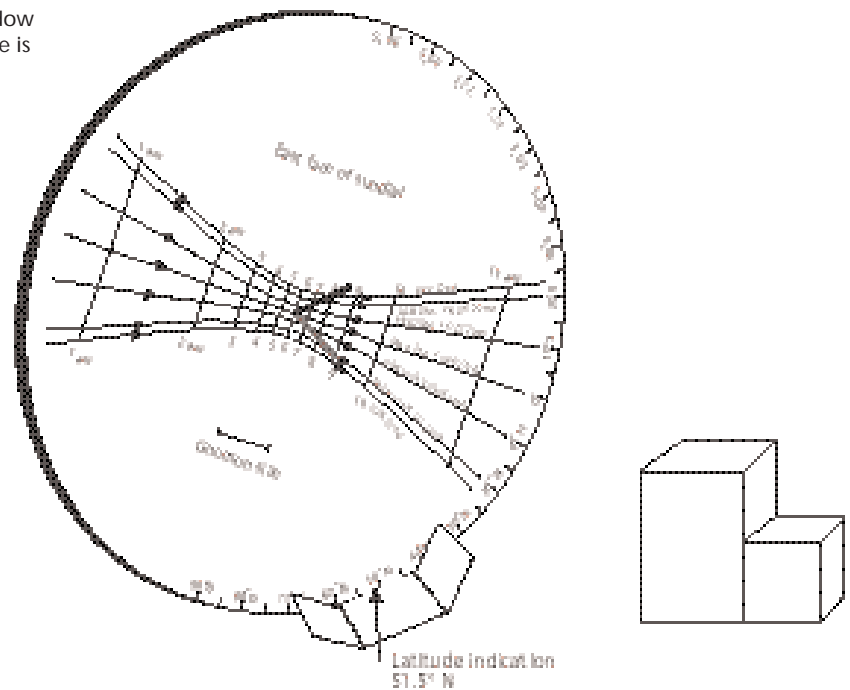

rotated and tilted so that the shadow of the gnomon picks out the chosen hour and season.

The Cellini method is a quick alternative technique. It depends on the fact that the sun never 'sees' a shadow: a shadow simply defines an area hidden from direct sunlight. To use the Cellini method, align your eye with the tip of the gnomon and the relevant time/date marking on the sundial (see Figure 3.8). Since you are looking from the direction of the sun, those parts of the model that you can see will be sunlit and surfaces that are hidden will be in shadow.

The advantages of the Cellini method are that it requires only one person and no equipment besides the model and the sundial, and it can be used anywhere, without having to switch the lights off. The disadvantage is that it does not lend itself to photographic recording, so there will be no permanent record of the investigation.

References

- 1 Uhlrich R View through a window may influence recovery from surgery *Science* **224** pp 420-421 (1984)
- 2 Littlefair P J *Site layout planning for daylight and sunlight: a guide to good practice* BRE Report **BR209** (London: Construction Research Communications) (1991)
- 3 Yannas S *Solar energy and housing design* (London: Architectural Association/Energy Technology Support Unit) (1994)
- 4 *Climate and site development* BRE Digest **350** (London: Construction Research Communications) (1990)
- 5 *Natural ventilation in non-domestic buildings* BRE Digest **399** (London: Construction Research Communications) (1994)
- 6 *Natural ventilation in non-domestic buildings* CIBSE Applications Manual **AM10** (London: Chartered Institution of Building Services Engineers) (1997)
- 7 *Insulation against external noise* BRE Digest **338** (London: Construction Research Communications) (1988)
- 8 Tinsdeall N *The sound insulation provided by windows* BRE Information Paper **IP6/94** (London: Construction Research Communications) (1994)
- 9 Moore F *Concepts and practice of architectural daylighting* (New York: Van Nostrand Reinhold) (1985)
- 10 *BS 8206 Part 2: Code of practice for daylighting* (London: British Standards Institution) (1992)
- 11 Lynes J A A sequence for daylighting design *Lighting Res. Technol.* **11**(2) pp 102-106 (1979)
- 12 Anstey J *Rights of light and how to deal with them* (London: Surveyors Publications/RICS) (1988)
- 13 Ellis P *Rights to Light* (London: Estates Gazette) (1989)
- 14 Littlefair P J and Aizlewood M E *Daylighting in atrium buildings* BRE Information Paper **IP3/98** (London: Construction Research Communications) (1998)
- 15 Littlefair P J *Designing with innovative daylighting* BRE Report **BR305** (London: Construction Research Communications) (1996)
- 16 *CIBSE Guide A: Environmental design* (London: Chartered Institution of Building Services Engineers) (1999)
- 17 *ASHRAE Handbook of Fundamentals* (Atlanta: American Society of Heating, Refrigerating and Air-Conditioning Engineers) (1997)
- 18 *Environmental design guide* (London: Construction Research Communications) (1999)
- 19 *Office environment designer software* (Milton Keynes: National Energy Services) (1997)
- 20 *CIBSE Guide Section A3: Thermal properties of building structures* (London: Chartered Institution of Building Services Engineers) (1999)
- 21 *CIBSE Guide Section A1: Environmental criteria for design* (London: Chartered Institution of Building Services Engineers) (1999)
- 22 *CIBSE Guide Section A2: External design data* (London: Chartered Institution of Building Services Engineers) (1999)
- 23 *ISO/DIS 14438 Glass in building: determination of energy balance value — calculation method* (London: British Standards Institution) (1998)
- 24 *CIBSE Guide Section A4: Air infiltration and natural ventilation* (London: Chartered Institution of Building Services Engineers) (1999)
- 25 Baker N V and Steemers K *The LT method 2.0* (Cambridge: Cambridge Architectural Research, available from BRECSU, Garston) (1984)
- 26 Dewey E and Littlefair P J Rooflight spacing and uniformity *Lighting Res. Technol.* **30**(3) pp 119-125 (1998)
- 27 *CIBSE Code for interior lighting* (London: Chartered Institution of Building Services Engineers) (1994)
- 28 Walker R R How deep an office *Bldg. Services* **14**(4) p 57 (1992)
- 29 Walker R R and White M K Single-sided natural ventilation: How deep an office *BSE&T* **13**(4) pp 231-236 (1992)
- 30 White M K and Walker R R The effectiveness of natural ventilation in offices *Proc IMechE seminar on The development of passive buildings — future or folly?* (London: Imperial College) (1994)
- 31 *BS 5925 Code of practice for ventilation principles and designing for natural ventilation* (London: British Standards Institution) (1991)
- 32 *BREEZE 6.0 user manual* (London: Construction Research Communications) (1993)
- 33 Givoni B *Man, Climate and Architecture* (London: Elsevier) (1969)
- 34 *CIBSE Guide F: Energy efficiency in buildings* (London: Chartered Institution of Building Services Engineers) (1998)
- 35 *CDM Regulations – work sector guidance for designers* CIRIA Report **166** (London: Construction Industry Research and Information Association) (1995)
- 36 Button D A and Pye D B (eds) *Glass in Building* (Oxford: Butterworth) (1993)
- 37 Lampert C M and Ma Y-P *Fenestration 2000 Phase III: Advanced glazing materials study* ETSU Report **S1215** (Harwell: Energy Technology Support Unit) (1992)
- 38 Boyce P, Eklund N, Mangum S, Saalfeld M S and Tang L Minimum acceptable transmittance of glazing *Lighting Res. Technol.* **2** (3) pp 145-152 (1995)
- 39 Cooper J R, Wiltshire T J and Hardy A G Attitudes towards the use of heat rejecting/ low light transmission glasses in office buildings *Proc CIE Symposium on Windows and their functions in architectural design, Istanbul* paper P (Vienna: Commission Internationale de l'Éclairage) (1973)
- 40 Cuttle C Subjective assessments of the appearance of special performance glazing in offices *Lighting Res. Technol.* **11**(3) pp 140-149 (1979)
- 41 Littlefair P J *Solar dazzle reflected from sloping glazed facades* BRE Information Paper **IP3/87** (London: Construction Research Communications) (1987)
- 42 *The influence of trees on house foundations in clay soils* BRE Digest **298** (London: Construction Research Communications) (1985)
- 43 *Display screen equipment work. Health and Safety (Display Screen Equipment) Regulations 1992. Guidance on regulations* (Sudbury: Health and Safety Executive) (1992)
- 44 *The visual environment for display screen use* CIBSE Lighting Guide **LG3** (London: Chartered Institution of Building Services Engineers) (1996)
- 45 Cakir A E *An investigation on state-of-the-art and future prospects of lighting technology in German office environments* (Berlin: Ergonomics Institute for Social and Occupational Sciences Research) (1991)
- 46 Littlefair P J *Daylighting design for display screen equipment* BRE Information Paper **IP10/95** (London: Construction Research Communications) (1995)
- 47 *Lighting for museums and art galleries* CIBSE Lighting Guide **LG8** (London: Chartered Institution of Building Services Engineers) (1994)
- 48 Hamlyn R (ed) *The Clore Gallery* (London: Tate Gallery) (1987)

- 49 *BS 5544: Specification for anti-bandit glazing (glazing resistant to manual attack)* (London: British Standards Institution) (1978)
- 50 *BS 5051-1: Bullet resistant glazing: Part 1 Specification for glazing for interior use* (London: British Standards Institution) (1988)
- 51 Garvin S *Domestic automatic doors and windows for use by elderly and disabled people: a guide for specifiers* BRE Report **BR334** (London: Construction Research Communications) (1997)
- 52 *Sound insulation: basic principles* BRE Digest **337** (London: Construction Research Communications) (1988)
- 53 *BS 8233: Codes of practice for sound insulation and noise reduction in buildings* (London: British Standards Institution) (1987)
- 54 Slater A I *Lighting controls: an essential element of energy efficiency* BRE Information Paper **IP5/87** (London: Construction Research Communications) (1987)
- 55 *Lighting controls and daylight use* BRE Digest **272** (London: Construction Research Communications) (1983)
- 56 Crisp V H C and Henderson G The energy management of artificial lighting use *Lighting Res. Technol.* **14**(4) pp 193-206 (1982)
- 57 Slater A I, Bordass W T and Heasman T A *People and lighting controls* BRE Information Paper **IP6/96** (London: Construction Research Communications) (1996)
- 58 Hunt D R G *Availability of daylight* BRE Report **BR21** (London: Construction Research Communications) (1979)
- 59 Tregenza P R (ed) *European daylighting atlas* (Brussels: Commission of the European Communities Brussels) (in press)
- 60 Littlefair P J Predicting annual lighting use in daylit buildings *Building and Environment* **2**(1) pp 43-54 (1990)
- 61 Lynes J A and Littlefair P J Lighting energy savings from daylight: estimation at the sketch design stage *Lighting Res. Technol.* **22**(3) pp 129-137 (1990)
- 62 Hunt D R G Predicting lighting use — a method based upon observed patterns of behaviour *Lighting Res. Technol.* **12**(1) pp 7-14 (1980)
- 63 Secker S M and Littlefair P J Daylight availability and lighting use: geographical variations *Lighting Res. Technol.* **19**(2) 25-34 (1987)
- 64 Littlefair P J and Lynes J A Responding to change *Light and Lighting* **7** pp 27-28 (1999)
- 65 *Electric lighting controls: a guide for designers, installers and users* BRECSU Good Practice Guide **160** (Garston: BRECSU, Building Research Establishment) (1997)
- 66 *Standardisation of luminance distribution on clear skies* CIE Publication **22** (Vienna: Commission Internationale d'Eclairage) (1973)
- 67 *Estimating daylight in buildings: parts 1 and 2* BRE Digests 309 and 310 (London: Construction Research Communications) (1985)
- 68 Lynes J A *Principles of natural lighting* (London: Elsevier) (1968)
- 69 Littlefair P J Designing for daylight availability using the BRE average sky *Proc CIBSE National Ltg Conf Warwick* (London: Chartered Institution of Building Services Engineers) (1982)
- 70 Littlefair P J, Lynes J A and Stupple S P Constraints on reflectance in artificial sky domes *Lighting Res. Technol.* **19**(4) 115-118 (1987)

Bibliography

Building types

The Chartered Institution of Building Services Engineers offers the following lighting publications:

- CIBSE code for interior lighting* (1994)
- Lighting requirements of Building Regulations Part L* (1996)
- LG1 *The industrial environment* (1989)
- LG2 *Hospitals and health care buildings* (1989)
- LG3 *The visual environment for display screen use* (1996)
- LG4 *Sports* (1989)
- LG5 *The visual environment in lecture, teaching and conference rooms* (1991)
- LG6 *The outdoor environment* (1992)
- LG7 *Lighting for offices* (1993)
- LG8 *Lighting for museums and art galleries* (1994)
- LG9 *Lighting for communal and residential buildings* (1997)

BRECSU (Building Research Establishment, Garston) offers the following Good Practice Guides, General Information Leaflets, Reports and Maxibrochures:

- GPG152 *Energy efficient refurbishment of public houses — lighting*
- GPG158 *Energy efficiency in lighting for industrial buildings — a guide for building managers*
- GPG189 *Energy efficiency in hotels. A guide to cost effective lighting*
- GPG199 *Energy efficient lighting — a guide for installers*
- GPG210 *Energy efficient lighting in the retail sector*

- GPG223 *Cost effective lighting for sports facilities*
- GPG245 *Desktop guide to daylighting — for architects*
- GIL16 *Using solar energy in schools*
- GIR27 *Passive solar estate layout*
- GIR35 *Daylighting for sports halls. Two case studies*
- Energy efficient lighting in industrial buildings*
- Energy efficient lighting in offices*
- Energy efficient lighting in schools*

Buildings: case studies

- Fontoynton M (ed) *Daylight performance of buildings* (London: James & James) (1998)
- Lewis J O (ed) *Project Monitor* (Commission of the European Communities/University College Dublin) (1987-1989)
- Loe D and Mansfield K P *Daylighting design in architecture* (Garston: BRECSU, Building Research Establishment) (1998)
- Turrent D, Doggart J and Ferraro R *Passive solar housing in the UK* (London: Energy Conscious Design) (1981)

Daylight calculations

- Estimating daylight in buildings Parts 1 and 2* BRE Digests **309** and **310** (London: Construction Research Communications) (1986)
- Littlefair P J *Average daylight factor: a simple basis for daylight design* BRE Information Paper **IP15/88** (London: Construction Research Communications) (1988)

Littlefair P J Daylight coefficients for practical computation of internal illuminances *Lighting Res. Technol.* **24**(3) pp 127-135 (1992)

Lynes J A A sequence for daylighting design *Lighting Res. Technol.* **11**(2) pp 102-106 (1979)

Tregenza P R and Waters I M Daylight coefficients *Lighting Res. Technol.* **15**(2) pp 65-71 (1983)

Tregenza P R Daylighting computation: radiosity method using triangular patches *Lighting Res. Technol.* **26**(1) pp 1-7 (1994)

Tregenza P R Mean daylight illuminance in rooms facing sunlit streets *Building and Environment* **30**(1) pp 83-89 (1995)

Daylighting: general

Ander G D *Daylighting performance and design* (New York: Van Nostrand) (1995)

Baker N, Fanchiotti A and Steemers K (eds) *Daylighting in architecture* (London: James & James) (1993)

Baker N and Steemers K (eds) *Daylight design of buildings* (London: James & James) (1999)

Bell J and Burt W *Designing buildings for daylight* BRE Report **BR288** (London: Construction Research Communications) (1995)

BS8206 Part 2: Code of practice for daylighting (London: British Standards Institution) (1992)

Evans B H *Daylight in architecture* (New York: McGraw-Hill) (1981)

Hopkinson R G, Petherbridge P and Longmore J *Daylighting* (London: Heinemann) (1966)

Lam W *Sunlighting as formgiver for architecture* (New York: Van Nostrand) (1986)

Lynes J A *Principles of natural lighting* (London: Elsevier) (1968)

Moore F *Concepts and practice of architectural daylighting* (New York: Van Nostrand) (1985)

Robbins C L *Daylighting design and analysis* (New York: Van Nostrand) (1986)

Daylighting in buildings (Dublin: University College Dublin for European Commission) (1994)

Energy issues

Crisp V H C, Littlefair P J, Cooper I and McKennan G *Daylighting as a passive solar energy option: an assessment of its potential in non-domestic buildings* BRE Report **BR129** (London: Construction Research Communications) (1988)

Baldwin R, Yates A, Howard N and Rao S *BREEAM '98 for offices* BRE Report **BR350** (London: Construction Research Communications) (1998)

Goulding J R, Lewis J O and Steemers T C *Energy in architecture: the European Passive Solar Handbook* (London: Batsford) (1992)

Goulding J R, Lewis J O and Steemers T C *Energy conscious design: a primer for architects* (London: Batsford) (1992)

Glazing and innovative daylighting

Aizlewood M E Innovative daylighting systems: an experimental evaluation *Ltg. Res & Technol* **25**(4) pp 141-152 (1993)

D A Button and D B Pye *Glass in building* (Oxford: Butterworth/Pilkingtons) (1993)

Lampert C M and Ma Y-P *Advanced glazing materials study* ETSU Report **S1215** (Harwell: Energy Technology Support Unit) (1992)

Littlefair P J *Innovative daylighting systems* BRE Information Paper **IP22/89** (London: Construction Research Communications) (1989)

Littlefair P J Innovative daylighting: review of systems and evaluation methods *Lighting Res. Technol.* **2**(1) pp 1-18 (1990)

Littlefair P J *Designing with innovative daylighting* BRE Report **BR305** (London: Construction Research Communications) (1996)

Ruck N C Daylight in practice *Bldg. Services* **7**(4) pp 50-52 (1985)

Lighting controls

Electric lighting controls — a guide for designers, installers and users BRECSU Good Practice Guide **160** (Garston: BRECSU, Building Research Establishment) (1997)

Lighting controls and daylight use BRE Digest **272** (London: Construction Research Communications) (1983)

CIBSE Code for interior lighting (London: Chartered Institution of Building Services Engineers) (1994)

Crisp V H C The light switch in buildings *Lighting Res. Technol.* **10**(2) pp 69-82 (1978)

Crisp V H C and Henderson G The energy management of artificial lighting use *Lighting Res. Technol.* **14**(4) pp 193-206 (1982)

Hunt D R G The use of artificial lighting in relation to daylight levels and occupancy *Building and Environment* **14**(1) pp 21-33 (1979)

Hunt D R G Predicting lighting use — a method based upon observed patterns of behaviour *Lighting Res. Technol.* **12**(1) pp 7-14 (1980)

Lighting controls and energy management systems (London: Lighting Industry Federation) (1989)

Littlefair P J Predicting annual lighting use in daylit buildings *Building and Environment* **25**(1) pp 43-54 (1990)

Lynes J A and Littlefair P J Lighting energy savings from daylight: estimation at the sketch design stage *Lighting Res. Technol.* **22**(3) pp 129-137 (1990)

Slater A I *Lighting controls: an essential element of energy efficiency* BRE Information Paper **IP5/87** (London: Construction Research Communications) (1987)

Slater A I, Bordass W T and Heasman T A *People and lighting controls* BRE Information Paper **IP6/96** (London: Construction Research Communications) (1996)

Treado S and Kusuda T *Daylighting window management systems and lighting controls* NBS **IR80-2147** (Washington: National Bureau of Standards) (1980)

Verderber R R Review of lighting control equipment and applications *Energy Engng* **8**(1) pp 19-28 (1988)

Model studies

Egan M D *Concepts in artificial lighting* (New York: McGraw-Hill) (1983)

Littlefair P J and Lindsay C R T *Scale models and artificial skies in daylighting studies* BEPAC Technical Note **TN90/3** (Garston: Building Environmental Performance Analysis Club) (1991)

Littlefair P J *Measuring daylight* BRE Information Paper **IP23/93** (London: Construction Research Communications) (1993)

Longmore J The role of models and artificial skies in daylighting design *Trans IES (London)* **27**(3) pp 121-138 (1962)

Lynes J A Natural lighting: use of models *Architects J* **148**(43) pp 963-968 (1968)

Schiler M (ed) *Simulating daylight with architectural models* (Los Angeles: DNNA/University Southern California) (1991)

Tregenza P R Daylight measurement in models: new type of equipment *Ltg. Res & Technol.* **21**(4) pp 193-194 (1989)

Van Santen C and Hansen A J *Simulieren van daglicht (Simulation of daylight)* (Delft: Faculteit der Bouwkunde Technische Universiteit Delft) (1991)

Noise

Insulation against external noise BRE Digest **338** (London: Construction Research Communications) (1988)

Tinsdeall N *The sound insulation provided by windows* BRE Information Paper **IP6/94** (London: Construction Research Communications) (1994)

Planning site layout and Rights to Light

Anstey J *Rights of light and how to deal with them* (London: Surveyors Publications/RICS) (1988)

P Ellis *Rights to Light* (London: Estates Gazette) (1989)

Littlefair P J *Site layout planning for daylight and sunlight: a guide to good practice* BRE Report **BR209** (London: Construction Research Communications) (1991)

A study of passive solar housing estate layout ETSU Report **S1126** (Harwell: Energy Technology Support Unit/N B A Tectonics) (1988)

Robinette G O (ed) *Energy efficient site design* (New York: Van Nostrand) (1983)

Rooflights and atria

Bednar M J *The new atrium* (New York: McGraw Hill) (1986)

Littlefair P J and Aizlewood M E *Daylighting in atrium buildings* BRE Information Paper **IP3/98** (London: Construction Research Communications) (1998)

Saxon R *Atrium buildings development and design* (London: Architectural Press) (1983)

Solar shading

Lynes J A and Cuttle C *Bracelet for total solar shading* *Lighting Res. Technol.* **2**(3) pp 105-113 (1988)

Olgyay V and Olgyay A *Solar control and shading devices* (Princeton: Princeton University Press) (1963)

Subjective aspects including glare and view out

The visual environment for display screen use CIBSE Lighting Guide **LG3** (London: Chartered Institution of Building Services Engineers) (1996)

Chauvel P, Collins J B, Dogniaux R and Longmore J *Glare from windows: current views of the problem* *Lighting Res Technol.* **14**(1) pp 31-46 (1982)

Collins B L *Review of the psychological reaction to windows* *Lighting Res. Technol.* **8**(2) pp 80-88 (1976)

Display screen equipment work. Health and Safety (Display Screen Equipment) Regulations 1992. Guidance on regulations (Sudbury: Health and Safety Executive) (1992)

Littlefair P J *Daylighting design for display-screen equipment* BRE Information Paper **IP11/95** (London: Construction Research Communications) (1995)

Littlefair P J *Solar dazzle reflected from sloping glazed facades* BRE Information Paper **IP3/87** (London: Construction Research Communications) (1987)

Perry M J and Gardner L *Daylighting requirements for display-screen equipment* BRE Information Paper **IP14/93** (London: Construction Research Communications) (1993)

Sunlight

Knowles R L *Sun rhythm form* (Cambridge: MIT Press) (1981)

Neeman E *Visual aspects of sunlight in buildings* *Lighting Res. Technol.* **6**(3) pp 159-164 (1974)

Neeman E, Craddock J and Hopkinson R G *Sunlight requirements in buildings: 1 Social survey* *Building & Environment* **11** pp 217-233 (1976)

Neeman E, Light W and Hopkinson R G *Recommendations for the admission and control of sunlight in buildings* *Building & Environment* **11** pp 91-101 (1976)

Neeman E and Light W *Availability of sunshine* BRE Current Paper **CP75/75** (London: Construction Research Communications) (1975)

Sunlight availability protractor BRE Report **BR12** (London: Construction Research Communications) (1975)

Ventilation

Natural ventilation in non-domestic buildings BRE Digest **399** (Garston: Construction Research Communications) (1994)

Natural ventilation in non-domestic buildings CIBSE Applications Manual **AM10** (London: Chartered Institution of Building Services Engineers) (1997)

Window design (general)

Brown G Z *Sun, wind and light: architectural design strategies* (New York: Wiley) (1985)

Turner (ed) D P *Windows and Environment* (London: Architectural Press) (1969)

Yannas S *Solar energy and housing design* (London: Architectural Association/ETSU) (1994)

Statutory Instruments

Published by The Stationery Office, London:

The Building Regulations 1991

B: Fire Safety

F: Ventilation

L: Conservation of Heat and Power

N: Glazing — Safety in relation to impact, opening and cleaning

The Building Standards (Scotland) Regulations 1990

D: Structural fire precautions

E: Means of escape from fire, facilities for fire-fighting and means of warning of fire in dwellings

F: Conservation of heat and power

K: Ventilation

P: Miscellaneous hazards

The Building Regulations Northern Ireland 1990

E: Fire safety

EE: Fire

J: Conservation of Heat and Power

K: Ventilation

V: Glazing

The Construction (Design and Management) Regulations 1994

The Health and Safety (Display Screen Equipment) Regulations 1992

Appendix A1 Supplementary data

A1.1 Glass and window performance data

In section 2.3, reference has been made to the different families of glass. Selected performance data are given in Tables A1.1-A1.8 for single glazing, frames, multiple glazing and for glazing with blinds. Note that the data presented here can only be representative of the wide range of basic glasses available from different manufacturers. In these tables:

- T is diffuse light transmission (manufacturer's catalogues usually give the direct transmission which is higher)
- T_D is direct transmittance of total solar radiation (normal incidence)
- R is reflectance for total solar radiation (normal incidence)
- A is absorptance of total solar radiation (normal incidence)
- T_T is total transmittance of total solar radiation (normal incidence). Includes radiation absorbed in the glazing and then reradiated or transferred into the room

Table A1.1 Properties of clear float glass

Thickness (mm)	Light	Solar radiant heat					Shading coefficient			Solar gain factor	U value (W/m ² K)
	T	T_D	R	A	T_T	SW	LW	Total	S_e		
2	0.84	0.88	0.07	0.05	0.90	1.01	0.02	1.03	0.82	5.5	
3	0.83	0.85	0.07	0.08	0.88	0.98	0.03	1.01	0.81	5.5	
4	0.82	0.82	0.07	0.11	0.86	0.94	0.04	0.98	0.78	5.4	
5	0.81	0.80	0.07	0.13	0.84	0.92	0.05	0.97	0.77	5.4	
6	0.80	0.78	0.07	0.15	0.83	0.90	0.05	0.95	0.76	5.4	
8	0.78	0.74	0.07	0.19	0.80	0.85	0.07	0.92	0.74	5.3	
10	0.77	0.70	0.07	0.23	0.78	0.80	0.09	0.89	0.71	5.3	
12	0.75	0.67	0.06	0.27	0.76	0.77	0.10	0.87	0.70	5.2	
15	0.74	0.62	0.06	0.32	0.73	0.71	0.13	0.84	0.67	5.1	
19	0.71	0.56	0.05	0.39	0.69	0.64	0.15	0.79	0.63	5.0	
25	0.67	0.49	0.05	0.46	0.64	0.56	0.18	0.74	0.59	4.9	

Table A1.2 Properties of a typical range of body-tinted glasses

Type	Light	Solar radiant heat					Solar gain factor	Shading coefficients		
	T	T_D	R	A	T_T	S_e	SW	LW	Totals	
6 mm green	0.66	0.46	0.05	0.49	0.62	0.58	0.58	0.19	0.72	
6 mm blue	0.50	0.46	0.05	0.49	0.62	0.58	0.53	0.19	0.72	
6 mm grey	0.39	0.42	0.05	0.53	0.60	0.55	0.48	0.21	0.69	
6 mm bronze	0.46	0.46	0.05	0.49	0.62	0.58	0.53	0.19	0.72	
10 mm grey	0.23	0.25	0.04	0.71	0.49	0.45	0.29	0.27	0.56	
10 mm bronze	0.30	0.29	0.04	0.67	0.51	0.47	0.33	0.26	0.59	

Table A1.3 Properties of a typical range of coated glasses

Type	Light	Solar radiant heat					Solar gain factor	Shading coefficients		
	T	T_D	R	A	T_T	S_e	SW	LW	Totals	
6 mm silver	0.09	0.08	0.32	0.40	0.23	0.21	0.09	0.17	0.26	
6 mm bronze	0.09	0.06	0.21	0.73	0.24	0.22	0.07	0.20	0.27	
6 mm blue	0.18	0.15	0.21	0.64	0.33	0.30	0.17	0.21	0.38	

- shading coefficient is the total transmittance for solar radiation divided by 0.87 which is the nominal value for 4 mm clear glass. It can be divided into short wave (SW) and long wave (LW) components
- S_e is solar gain factor: the ratio of the daily mean solar heat gain through glazing to the daily mean radiant flux incident on the glazing.

The visible reflectance properties for all glasses vary with angle of incidence and are enhanced if the glass is coated. For most interior daylight calculations it is reasonable to assume a value of 0.1. For the calculation of reflected solar glare to the outside (section 2.3.3) a more detailed analysis is needed using the manufacturer's data for the particular glazing.

Table A1.4 Indicative U-values (W/m^2K) for glazing in different types of frames in windows and rooflights

Air gaps in sealed unit (mm)	Wood		Metal		Thermal break		PVC	
	6	12	6	12	6	12	6	12
Double glazed	3.3	3.0	4.2	3.8	3.6	3.3	3.3	3.0
Double glazed (low E)	2.9	2.4	3.7	3.2	3.1	2.6	2.9	2.4
Double glazed (argon)	3.1	2.9	4.0	3.7	3.4	3.2	3.1	2.9
Double glazed (low E + argon)	2.6	2.2	3.4	2.9	2.8	2.4	2.6	2.2
Triple glazed	2.6	2.4	3.4	3.2	2.9	2.6	2.6	2.4
Single glazed	4.7		5.8		5.3		4.7	

Low E Low emissivity glass

Table A1.5 Multiple glazing performance data (indicative)

Glazing system (all glasses 6 mm, all cavities 12 mm)	U-value (W/m^2K)	Total transmission	Light T
Single glazing clear float	5.45	0.86	0.82
Double glazing clear float	2.80	0.76	0.70
Double glazing clear float + low E glass	1.90	0.72	0.69
Double glazing low E glass + low E glass	1.75	0.66	0.65
Double glazing clear float + low E glass + argon	1.60	0.72	0.69
Double glazing low E glass + low E glass + argon	1.40	0.66	0.65
Triple glazing clear float	1.85	0.67	0.66
Triple glazing low E glass+ F + low E glass	1.15	0.59	0.60
Triple glazing low E glass+ F + low E glass + argon	0.95	0.59	0.60
Triple glazing low E glass+ F + low E glass + krypton	0.70	0.59	0.60
Triple glazing HP neutral + F + HP neutral + krypton	0.60	0.33	0.30
Triple glazing HP neutral + F + HP neutral + argon	0.85	0.33	0.30
Quadruple clear float + air	1.40	0.60	0.60
Quadruple clear float + argon	1.30	0.60	0.60
Single glazing body-tinted (green)	5.45	0.62	0.66
Single glazing body-tinted (bronze)	5.45	0.62	0.46
Single glazing body-tinted (blue)	5.45	0.62	0.50
Single glazing body-tinted (grey)	5.45	0.60	0.39

F Clear float, HP High performance, Low E Low emissivity

Table A1.6 Properties for single glazing with internal blind

Type (all 6 mm thick)	Solar radiant heat				Solar gain factor S_e	Shading coefficient		
	T_D	R	A	T_T		SW	LW	Total
Clear	0.09	0.39	0.52	0.47	0.19	0.10	0.44	0.54
<i>Absorbing</i>								
Green	0.05	0.16	0.79	0.42	0.16	0.06	0.43	0.49
Blue	0.05	0.15	0.80	0.42	0.16	0.06	0.42	0.48
Grey	0.05	0.14	0.81	0.43	0.15	0.05	0.44	0.49
Bronze	0.05	0.15	0.80	0.42	0.16	0.06	0.42	0.48
<i>Reflecting</i>								
Silver	0.01	0.32	0.67	0.21	0.07	0.01	0.23	0.24
Bronze	0.01	0.21	0.78	0.22	0.07	0.01	0.24	0.25
Blue	0.03	0.21	0.76	0.32	0.11	0.03	0.34	0.37
Blind, slats angled at 45°	0.11	0.50	0.39					

Table A1.7 Properties for double glazing with internal blind (6 mm clear inner glass)

Type (all 6 mm thick)	Solar radiant heat				Solar gain factor S_e	Shading coefficient		
	T_D	R	A	T_T		SW	LW	Total
Clear	0.07	0.31	0.62	0.47	0.18	0.08	0.46	0.54
<i>Absorbing</i>								
Green	0.04	0.13	0.83	0.36	0.13	0.05	0.36	0.41
Blue	0.04	0.13	0.83	0.33	0.13	0.05	0.36	0.41
Grey	0.04	0.12	0.84	0.34	0.12	0.04	0.35	0.39
Bronze	0.04	0.13	0.83	0.35	0.11	0.05	0.35	0.40
<i>Reflecting</i>								
Silver	0.01	0.32	0.67	0.14	0.05	0.01	0.15	0.16
Bronze	0.01	0.21	0.78	0.15	0.05	0.01	0.16	0.17
Blue	0.02	0.20	0.78	0.24	0.08	0.02	0.25	0.27
Blind, slats angled at 45°	0.11	0.50	0.39					

Table A1.8 Properties for double window with blind between panes (inner glass 6 mm clear)

Type (all 6 mm thick)	Solar radiant heat				Solar gain factor S_e	Shading coefficient		
	T_D	R	A	T_T		SW	LW	Total
Clear	0.07	0.39	0.54	0.25	0.12	0.08	0.21	0.29
<i>Absorbing</i>								
Green	0.04	0.16	0.80	0.23	0.09	0.05	0.22	0.27
Blue	0.04	0.15	0.81	0.23	0.09	0.05	0.21	0.26
Grey	0.04	0.14	0.82	0.21	0.08	0.04	0.20	0.24
Bronze	0.04	0.15	0.81	0.23	0.09	0.05	0.21	0.26
<i>Reflecting</i>								
Silver	0.01	0.23	0.67	0.12	0.04	0.01	0.13	0.14
Bronze	0.01	0.21	0.78	0.13	0.04	0.01	0.14	0.15
Blue	0.02	0.21	0.77	0.18	0.07	0.03	0.17	0.20
Blind, slats angled at 45°	0.11	0.50	0.39					

A1.2 Maintenance factors

The maintenance factor allows for the reduction of daylight transmittance due to dirt. First, find the basic loss of light in the particular building type, then multiply it by the special factors (see Tables A1.9-A1.11) if necessary. For example, using the tables, consider leaded glazing in a rural house. The loss of light will be $4\% \times 3 \times 1 = 12\%$. The maintenance factor M will be $100\% - 12\% = 88\% = 0.88$.

Table A1.9 Percentage loss of daylight compared with clean glazing

Room use	Rural/suburban	Urban
Residential: private and communal — rooms with few occupants, good maintenance	4	8
Commercial, educational — rooms used by groups of people, office equipment	4	8-12
Polluted atmosphere — gymnasia, swimming pools, heavy smoking	12-24	12-24

Table A1.10 Special conditions multiplier for calculating maintenance factor

Condition	Multiplier
Vertical glazing sheltered from rain	×3
Weathered or corroded glazing (no correction for rain exposure)	×3
Leaded glazing	×3

Table A1.11 Exposure multiplier for calculating maintenance factor

	Vertical glazing	Inclined glazing	Horizontal glazing
Normal exposure for location	×1	×2	×3
Exposed to heavy rain	×0.5	×1.5	×3
Exposed to snow	×1	×3	×4

A1.3 Reflectances of surfaces

The reflectances for a range of common building materials are given in Table A1.12.

Table A1.12 Reflectances of common materials⁽¹¹⁾

Material	Reflectance (R)	Material	Reflectance (R)
Windows		Floors and furniture	
Glass	0.1	Paper, white	0.8
Ceilings		Cement screed; PVC tiles, cream; carpet: light grey, middle buff	0.45
White emulsion paint on plain plaster surface	0.8	Timber, beech, birch, maple	0.35
White emulsion paint on acoustic tile	0.7	Timber, oak; PVC tiles, brown and cream marbled; carpet, turquoise, sage green	0.25
White emulsion paint on no-fines concrete	0.6	Timber, iroko, keruing, medium oak; tiles, cork, polished	0.2
White emulsion paint on wood wool slab	0.5	Quarry tiles, red, heather brown; carpet (dark, low maintenance); PVC tiles, dark brown; timber, dark oak	0.1
Walls		Paint colours (with BS 4800 colour code)	
White emulsion paint on plain plaster surface; tiles, white glazed	0.8	White 00E55	0.85
Brick, white gault	0.7	Pale cream 10C31	0.81
Plaster, pink	0.65	Light grey 00A01	0.68
White asbestos cement; brick, concrete, light grey; Portland cement, smooth	0.4	Strong yellow 10E53	0.64
Stainless steel	0.35	Mid grey 00A05	0.45
Brick, fletton	0.3	Strong green 14E53	0.22
Concrete, light grey; Portland cement, rough; brick, London stock; timber panelling, light oak, mahogany, gaboon	0.25	Strong red 04E53	0.18
Timber panelling, teak, afromosia, medium oak; brick, concrete, dark grey	0.2	Strong blue 18E53	0.15
Brick, blue engineering	0.15	Dark grey 10A11	0.14
Chalkboard, painted black	0.05	Dark brown 08C39	0.1
		Dark red/purple 02C39	0.1
		Black 00E53	0.05

Glossary

Some of the definitions given below will not be found in official publications. A simpler form has sometimes been adopted to aid the understanding of the terms involved. A full technical glossary is given in the CIBSE *Code for interior lighting*⁽²⁷⁾.

Artificial sky

A chamber or room in which models of buildings are placed to test their daylighting characteristics. The chamber usually has a light distribution that simulates the CIE standard overcast sky.

Atrium

An interior light space enclosed on two or more sides by the walls of a building and daylit from a roof of transparent or translucent material and, sometimes, from glazed ends or sides. It permits the entry of light to the other interior spaces linked to it by glazed or unglazed openings.

Average daylight factor

The average indoor illuminance on a reference plane or planes (usually the working plane) as a percentage of the simultaneous outdoor illuminance from the unobstructed sky. This is equal to the spatial average of daylight factors over the reference plane or planes.

Borrowed light

Light received through a window of an internal room or space, which opens into another internal room or space which is itself daylit. They rarely bring much daylight into a space but they can provide welcome views of daylit areas.

CIE

The Commission Internationale d'Eclairage (International Commission on Illumination), the international body responsible for lighting matters.

CIE standard clear sky

Cloudless sky for which the relative luminance distribution is described in CIE Publication 22⁽⁶⁶⁾. This sky is much brighter near to the sun. In contrast to the overcast sky, the horizon is brighter than the zenith so more light will be received in sidelit rooms.

CIE standard overcast sky

Completely overcast sky for which the ratio of its luminance L_γ at an angle of elevation γ above the horizon to the luminance L_z at the zenith is given by

$$L_\gamma = L_z(1 + 2\sin\gamma)/3$$

Clear sky

Sky unobstructed by cloud.

Clerestory window

Usually a strip of windows placed high in a wall but can also refer to a high level single window.

Colour rendering

Colour rendering is a general expression for the appearance of surface colours when illuminated by light from a given source compared, consciously or unconsciously, with their appearance under light from some reference source. Good colour rendering implies similarity of appearance to being under daylight.

Contrast

A term used subjectively and objectively. Subjectively, it describes the difference in appearance of two parts of a visual field seen simultaneously or successively. The difference may be one of brightness or colour or both. Objectively, the term expresses the luminance difference between the two parts of the field by such relationships as

$$\text{Contrast} = (L_2 - L_1)/L_1$$

Daylight

The combination of sunlight and skylight.

Daylight factor

The illuminance received at a point indoors from a sky of known or assumed luminance distribution, expressed as a percentage of the horizontal illuminance outdoors from an unobstructed hemisphere of the same sky. Direct sunlight is excluded from both values of illuminance. In this document the reference sky used is the CIE standard overcast sky defined above. See also *Average daylight factor*.

Diffuse daylight

See *Skylight*.

Direct skylight

Light received directly from the sky.

Externally reflected component (ERC) of daylight factor

The illuminance received directly at a point indoors from a sky of known or assumed luminance distribution after reflection from an external reflecting surface, expressed as a percentage of the horizontal illuminance outdoors from an unobstructed hemisphere of the same sky. Direct or reflected sunlight is excluded from both illuminances.

Glare

The discomfort or impairment of vision experienced when parts of the visual field are excessively bright in relation to the general surroundings. Disability glare is glare produced directly or by reflection that impairs the vision of objects without necessarily causing discomfort. Discomfort glare is glare which causes visual discomfort but without impairing the ability to see an object.

Illuminance

The amount of light falling on a surface per unit area, measured in lux.

Internally reflected component (IRC) of daylight factor

The illuminance received at a point indoors from a sky of known or assumed luminance distribution after reflection within the interior, expressed as a percentage of the horizontal illuminance outdoors from an unobstructed hemisphere of the same sky. Direct or reflected sunlight is excluded from both illuminances.

Light shelf

A horizontal reflecting component forming part of or fixed near the top of a window to reflect/bounce daylight onto the ceiling of the room/internal space. It can be fixed to the window externally, internally or both.

Limiting depth

The maximum depth of a room that can be satisfactorily daylit throughout from windows on one side.

Low emissivity glass

Glass with a selective heat-reflecting coating applied to it.

Luminance

The physical measurement of brightness (cd m^{-2}).

Lux

The SI unit of illuminance.

Maintenance factor

For daylighting, this is taken to be the proportion of incoming daylight which enters a window without being absorbed or reflected out by dirt, averaged over a complete window cleaning cycle. (Note: this is different from the maintenance factors used in electric lighting, which commonly refer to the end of the maintenance cycle.)

Minimum daylight factor

The lowest value of daylight factor on a reference plane or planes. For normal tasks the minimum daylight factor is taken to be on a horizontal working plane and at least 1 m from the walls.

No-sky line

The outline on a given reference plane of the area from which no sky can be seen. Usually the reference plane is taken to be a horizontal working plane, but it can be another surface such as a wall or floor.

Orientation factor

A factor to take account of the different amounts of light that windows of different orientations receive.

Orientation-weighted daylight factor

The product of the daylight factor multiplied by the appropriate orientation factor.

Passive solar design

Use of the design of the building itself — form, orientation, construction, plan and section — to exploit both solar energy (in the form of sunlight, daylight and natural ventilation) and other physical phenomena (such as the stack effect) to create comfortable internal conditions throughout the year and to use less energy in doing so.

Possible sunlight hours

The total number of hours during the year in which the centre of the sun is above the unobstructed horizon.

Probable sunlight hours

The long-term average of the total number of hours during the year in which direct sunlight reaches the unobstructed ground. It allows for average levels of cloud cover for the location in question.

Reflectance

The ratio of the luminous flux reflected from a surface to the luminous flux incident on it. Reflectance depends on how the surface is illuminated, and especially the direction of the incident light (except for matt surfaces) and its spectral distribution. The value is always less than unity and is expressed as either a decimal or percentage.

Rooflight

Daylight opening in the roof of a building.

Room index

An index related to the dimensions of a room and given (for the purposes of this guide) by

$$\text{Room index} = \frac{L \times W}{H_r(L + W)}$$

where L is the depth of the room, W its width and H_r its ceiling height above the working plane.

Shading coefficient

A number used to compare the solar radiant heat transmission properties of different glazing systems. It is calculated by dividing the total solar radiant heat transmittance of the material by 0.87, which is the total radiant heat transmittance of notional single clear glass of 4 mm thickness.

Sky angle

See *Vertical sky angle*.

Sky component (sc) of daylight factor

Ratio of that part of the daylight illuminance at a point on a given plane which is received directly through glazing from a sky of assumed or known luminance distribution to the illuminance on a horizontal plane due to an unobstructed hemisphere of this sky. Direct sunlight is excluded from both values of illuminance. Usually expressed as a percentage.

Sky factor

The ratio of the part of the skylight illuminance at a point on a given plane which would be received directly through unglazed openings from a sky of uniform luminance to the illuminance on a horizontal plane due to an unobstructed hemisphere of this sky. Usually expressed as a percentage.

Skylight

Light which has been scattered by molecules of air, aerosols and particles such as water droplets in clouds in the atmosphere; excludes direct beam.

Solar altitude

Angular height of the sun above the horizon.

Solar azimuth

The horizontal angle or bearing of the sun from due north in a clockwise direction.

Solar declination

At any moment the sun is vertically overhead at some point on the surface of the earth. The solar declination, which follows an annual cycle, is the latitude of the place at which the sun is vertically overhead; see Table 3.4

Solar gain factor

The ratio of the daily mean solar heat gain (W) through glazing to the daily mean radiant flux (W) incident on the glazing.

Specular surface

A surface with reflective properties where the angle of visible incident radiation is equal to the angle of reflection.

Stereographic projection

A geometric method of representing the hemisphere of the sky on a flat surface.

Sunlight

Visible direct beam solar radiation.

Top lighting

Light which enters through the top part of an interior space, e.g. through clerestories, light ducts or rooflights.

Transmittance

The ratio of luminous flux transmitted by a material to the incident luminous flux upon it.

U-value

The thermal transmittance of a material (W/m^2K).

Uniform sky

A (theoretical) sky whose luminance is the same in all directions.

Vertical sky angle

The angle of sky visible from the centre of a window, measured in the vertical plane perpendicular to the surface of the window.

Vertical sky component

The illuminance on the outside of a vertical window or wall surface from light coming directly from the overcast sky expressed as a percentage of the illuminance falling on unobstructed ground.

Visible sky angle

See *Vertical sky angle*.

Window

A manufactured building component fitted into a vertical opening in the external wall of a building in order to provide daylight, view and, if it is an opening window as opposed to a fixed one, ventilation.

Working plane

The horizontal, vertical or inclined plane in which a visual task lies. The working plane is normally taken as 0.7 m above the floor for offices and 0.85 m for industry.

Zenith

The part of the sky which is directly overhead.

List of symbols

γ	altitude in sky (degrees or radians)	N	number of air changes per hour
θ	vertical angle of visible sky (degrees)	R	area-weighted average reflectance of interior surfaces
a	coefficient in internally reflected component equation (see Table 3.2)	R_b	average reflectance of surfaces in the rear half of the room
A	total area of interior surfaces (ceiling + floor + walls, including windows) (m ²)	R_{cw}	average reflectance of the ceiling and parts of the walls above the mid-height of the window (excluding the window wall)
A_f	net area of floor (m ²)	R_{fw}	average reflectance of the floor and parts of the walls below the mid-height of the window (excluding the window wall)
A_s	absorptance of total solar radiation (normal incidence)	R_s	reflectance for total solar radiation (normal incidence)
A_w	net area of glazing (m ²)	S_e	solar gain factor
C	coefficient depending on the obstruction outside the window	T	diffuse transmittance of glazing material
df	average daylight factor (%)	T_D	direct transmittance of total solar radiation (normal incidence)
df_{min}	minimum daylight factor in a zone (%)	te	external temperature (°C)
e	coefficient in internally reflected component equation	t_g	thickness of glass (mm)
E_{out}	external illuminance (lux)	ti	internal temperature (°C)
f_{crit}	critical frequency (Hz)	T_s	diffuse visible transmittance of glazing
f_o	orientation factor	T_T	total transmittance of total solar radiation (normal incidence). Includes radiation absorbed in the glazing and then reradiated or transferred into the room
H_r	room height above working plane (m)	v	coefficient in internally reflected component equation (see Table 3.3)
h_w	height of top of window above working plane (m)	V	Total volume (m ³) of space
H_w	window head height above floor level (m)	W	room width (m)
H_{wp}	height of working plane above floor		
L	depth of room (m)		
L_γ	luminance of the sky at altitude γ (cd/m ²)		
L_z	zenith luminance (cd/m ²)		
M	maintenance factor (see appendix A1.2)		

Index

- A**
- Angle of elevation λ 21, 68
 Angle of visible sky θ 24-25, 30, 37, 70
 Artificial skies 73, 86
 Atmospheric pollution 16, 71
 Atria 9-10, 19, 28, 37-38, 53, 86
 Average daylight factor 25, 30-31, 37-38, 53, 55, 66, 68, 86
- Azimuth**
 angle 21, 68
 solar 88
- B**
- Blinds 43, 49-51, 52, 84
 Body-tinted glass 31, 45, 48, 82, 84
 Borrowed light 37, 86
 Building
 depth 16-20
 form 8-15
 obstructing 15, 16, 17-20, 24-25, 27
 orientation 21-24
 position 24-28
 size 16-20
- C**
- Car parking 28
 Case studies 19, 23, 24, 48, 54, 57, 67
 Checklists for design 6-7
 Cellini method 77
 CIE 86
 clear sky 69, 86
 overcast sky 68, 72, 73, 86
 Clear float glass, properties 82
 Clear sky 69, 86
 Clerestory windows 37, 54, 86
 Coated glass 45, 82
 Colour rendering 64, 86
 Computer models 72-73
 Constraints on daylighting 5-6
 Contrast 86
 Controls, lighting 14-15, 61-68
 Correction factors 71
 Courtyards 9, 18, 25, 27, 28
- D**
- Daylight 1-2, 86
 calculations 24-25, 30-31, 37, 68-77
 distribution . 4041
 illuminance 15, 55, 64-65
 redirecting systems 53-55
 requirements 29-30
 safeguarding 27
 Daylight factor 40, 64, 68, 69-71, 86
 average 25, 30-31, 37-38, 53, 55, 66, 68, 86
 minimum 66, 68, 87
 Declination, solar 76, 88
 Diffuse transmittance 30-31, 38, 48, 71, 82-83
 Dimming control 63, 65
 Direct skylight 86
 Disability glare 86
 Discomfort glare 86
 Display screen equipment 39, 51-53
 Double glazing 11, 14, 31, 32-33, 58
 for sound insulation 16, 60
- E**
- Electric lighting 14-15, 61-68
 control strategy 14-15, 61-68
 Electrochromic glass 47
 Energy efficiency 34-35, 61-69
 Exhibition displays 55-57
- Exposure of sites 6
 External
 horizontal illuminance 64-65
 shading devices 49-50, 53
 Externally reflected component 69, 70, 86
- F**
- Fire resistance 57
 Frames and supporting structures 57-58, 71, 83
- G**
- Glare 8, 12, 13, 39-40, 48, 52, 86
 Glass
 blocks 46
 body-tinted 31, 45, 48, 82
 clear float 82
 coated 45, 82
 diffuse transmittances of 31
 electrochromic 47
 laminated 46, 57, 60
 new developments 46
 patterned 46
 photovoltaic 47
 solar control 13, 45, 47-48
 surface-modified 45
 wired 46
 Glazing 13-14
 bars 71
 double glazing 11, 14, 31, 32-33, 58
 multiple 34, 60, 83
 types of 44-47
- H**
- Heat loss 14, 33-35
 Heat transmittance 14, 33, 47-48
- I**
- Illuminance 86
 Impact
 on adjacent buildings 27
 on open spaces 28
 Impact-resistant glazing 6, 46, 57
 Installation of windows 43-44
 Insulation
 frames 58, 83
 glass 33, 44, 45, 47
 sound 16, 44, 59-61
 thermal 11, 30, 33, 44, 45, 47-48, 58
- Internal**
 layout 28
 shading devices 49-50, 84
 Internally reflected component 69, 70-71, 72, 87
- L**
- Laminated glass 46, 57, 60
 Layout
 buildings 15-28
 internal 28
- Light**
 planning zones 61-63
 shelves 12, 14, 52, 53, 54-55, 87
 sources 63-64
 transmittance 30-31, 33, 45, 47-48, 55, 74, 82-84, 88
- Lighting** 14-15, 61-68
 Lighting control 14-15, 61-68
 dimming 63, 65
 hardware 64
 installation 68
 strategy 61-63
 switching 63
 Limiting depth 16-20, 87
- Low emissivity glass 31, 45, 87
 LT Method 34-35
 Luminance 87
 Lux 87
- M**
- Maintenance 43-44, 54
 Maintenance factor 31, 43, 71, 85, 87
 Manual calculations 69-71
 Massing 15-28
 Minimum daylight factor 66, 68, 87
 Models 73-77
 Multiple glazing 34, 60, 83
- N**
- Natural ventilation, *see ventilation*
 Night cooling 43
 Noise 6, 60
 insulation 16, 44, 59-61
 No-sky line 17-20, 29, 87
- O**
- Obstructions 15, 16, 17, 24-25
 Occupancy sensing 67
 Open spaces 28
 Orientation
 buildings 10-11, 21-24, 32, 33
 factor 64, 65, 66, 87
 weighted daylight factor 87
 windows 10, 42
 Overcast sky 68, 72, 73, 86
 Overshadowing 16
- P**
- Passive solar design 11, 15, 21, 87
 Patterned glass 46
 Photovoltaic glass 47
 Pollution 16, 71
 Position
 of building 24-28
 of windows 11-13, 38-41, 43
 Possible sunlight hours 87
 Prismatic glazing 52, 53
 Probable sunlight hours 24, 87
- R**
- Radiosity 72
 Ray-tracing 73
 Reflection, solar 39-40, 48, 52
 Reflectance, surface 31, 70, 71, 85, 87
 Refurbishments 5, 7
 Rights to light 27, 68
 Rooflights 7, 8, 29, 35-37, 40, 52-53, 87
 comparison 36
 maintenance 16
 spacing 35, 37
 Room index 87
- S**
- Safety 6, 46, 57
 Scale model studies 73-77
 Security 6, 43, 57
 Shades 43, 49-51, 52
 Shading 13-14, 21, 31, 49-55
 coefficient 32, 33, 82, 83, 87
 Shape of window 38-41, 42
 Sidelighting 6, 8, 16, 29, 69
 Site
 characteristics 15-16
 exposure of 6
 obstructions 16, 17-20, 24-25
 sloping 15-16

- | | | | | | |
|-------------------------------------|---------------------------------|------------------------|---|-----------------------------|--------------------------------|
| Siting | 15-29 | probable hours | 24, 87 | V | |
| Size | | studies | 75-77 | Ventilation | 4-5, 16, 33, 35, 41-43 |
| building | 17-20 | Sunpath diagram | 21-23 | Vertical sky angle θ | 24-25, 30, 38, 70, 88 |
| window | 11-13, 30-34, 38-41, 42 | Surface-modified glass | 45 | Vertical sky component | 24, 25, 27, 88 |
| Sky | | Surface reflectance | 31, 70, 71, 85, 87 | View | 3-4, 38-39 |
| angle | 87 | Switching | | Visible sky angle θ | 24-25, 30, 38, 70, 88 |
| clear | 69, 86 | control | 61-68 | Visual comfort | 32, 38, 39-40 |
| component | 69-70, 87 | manual | 66-68 | Visual display equipment | 39, 51-53 |
| factor | 68, 88 | occupancy sensing | 67 | | |
| glare | 39-40, 52 | photoelectric | 64-66 | W | |
| overcast | 68, 72, 73, 86 | Symbols | 89 | Window | 88 |
| Skylight | 88 | | | components | 13-14, 44-60 |
| indicator | 25-27 | T | | design process | 6-15 |
| Sloping sites | 15-16 | Thermal | | frames | 57-58, 71, 83 |
| Solar | | comfort | 33, 41-43, 46 | furniture and fittings | 58-59 |
| altitude | 88 | impact of windows | 13, 31-35, 83 | head height | 2, 6, 15, 16, 17-20, 40 |
| azimuth | 88 | inertial effects | 31-33 | installation | 43-44 |
| control glazing | 13, 45, 47-48 | insulation, frames | 58, 83 | opening area | 42, 43 |
| declination | 76, 88 | insulation, glass | 11, 30, 33, 44, 45, 47-48 | patterns | 40 |
| gain | 3, 10, 13-14, 28, 31-34, 40, 49 | Top lighting | 88 | position | 11-13, 38-41, 43 |
| gain factor | 88 | Transmittance | | shape | 38, 42 |
| glare | 39-40, 48, 52 | diffuse | 30-31, 38, 48, 71, 82-83 | size | 11-13, 30-34, 38-41, 42 |
| loads | 31-33 | heat | 14, 33, 47-48 | Wired glass | 46 |
| Sound insulation | 44, 59-61 | light | 30-31, 33, 45, 47-48, 55, 74, 82-84, 88 | Working plane | 16, 17, 29, 37, 69, 70, 74, 88 |
| Split-flux inter-reflection formula | 70, 72 | | | | |
| Stereographic projection | 21-23, 88 | U | | Z | |
| Sundial studies | 75-77 | Ultraviolet filtering | 55-56 | Zenith | 88 |
| Sunlight | 2-3, 88 | Uniform sky | 68, 88 | | |
| possible hours | 87 | U-value | 33-35, 47, 58, 83, 88 | | |

