

SPECIALIST PERIODICAL REPORTS

The Alkaloids

VOLUME 6

THE CHEMICAL SOCIETY

Specialist Periodical Reports

The enormous increase in the rate of accumulation of knowledge witnessed during the past few years now makes any attempt at comprehensive coverage of chemistry within the compass of a single annual volume, such as *The Chemical Society Annual Reports*, unattainable both in terms of reasonable size and cost.

It was with this in mind that in 1967 the Society launched the *Specialist Periodical Reports* series. The aim of the series is to provide systematic and comprehensive review coverage of the progress in the major areas of chemical research. The series has now reached some 35 titles, each being published in annual, or in some cases biennial, volumes.

The Society has been fortunate in obtaining the services of many leading experts in their specialist fields and the series thus provides a unique service for the active specialist chemist—critical in-depth accounts of the progress in their areas by acknowledged authorities, which usually appear less than twelve months after the period of literature coverage.

As the series grows towards its full complement of titles, it is intended that *Annual Reports on the Progress of Chemistry* will continue its shift in emphasis towards provision for the general reader of critical coverage of significant advances in all the major areas of chemistry.

For further details of related *Specialist Periodical Reports* see the back cover of this jacket. For a complete list and full information on all titles in the series write to:

The Marketing Officer
The Chemical Society
Burlington House
London W1V 0BN

ISBN 0 85186 307 8

ISSN 0305-9707

Library of Congress Catalog No. 70-616637

The Alkaloids

Volume 6

A Review of the Literature Published
between July 1974 and June 1975

Senior Reporter

M. F. Grundon, *School of Physical Sciences, New University of
Ulster, Coleraine, Northern Ireland*

Reporters

W. A. Ayer, *University of Alberta, Canada*

D. H. G. Crout, *University of Exeter*

G. Fodor, *West Virginia University, U.S.A.*

R. Goutarel, *Centre Nationale de la Recherche Scientifique, Gif-sur-Yvette,
France*

D. M. Harrison, *New University of Ulster*

R. B. Herbert, *University of Leeds*

Mme. F. Khuong-Huu, *Centre Nationale de la Recherche Scientifique,
Gif-sur-Yvette, France*

J. A. Lambertson, *C.S.I.R.O., Melbourne, Victoria, Australia*

N. J. McCorkindale, *University of Glasgow*

S. W. Page, *University of Georgia, U.S.A.*

S. W. Pelletier, *University of Georgia, U.S.A.*

A. R. Pinder, *Clemson University, South Carolina, U.S.A.*

J. E. Saxton, *University of Leeds*

M. Shamma, *Pennsylvania State University, U.S.A.*

© Copyright 1976

The Chemical Society
Burlington House, London, W1V 0BN

ISBN: 0 85186 307 8

ISSN: 0305-9707

Library of Congress Catalog No. 70-616637

Set in Times on Linotron and printed offset by
J. W. Arrowsmith Ltd., Bristol, England

Made in Great Britain

Foreword

This sixth volume of *Specialist Periodical Reports* devoted to the chemistry of alkaloids follows the policies developed so successfully in Volumes 1—5 by my predecessor as Senior Reporter, Dr. J. E. Saxton. The aim once again is to make the surveys comprehensive, this time covering the literature published during July 1974—June 1975.

Indole and isoquinoline alkaloids continue to play a dominant role. The aporphinoids, comprising proaporphines, aporphines and related dimers, are treated separately, partly in order to reduce the burden on contributors; aristolactams and aristolochic acids, which have not been reviewed since 1961, also are discussed in this chapter. This year the quinolizidine alkaloids, including the sesquiterpenoid *Nuphar* bases and the appropriate Lythraceae alkaloids, as well as azaphenalenes of plant and insect origin are reviewed together. Amaryllidaceae, *Erythrina*, imidazole, purine and peptide alkaloids are omitted from this volume, but it is expected that the chemistry of these groups covering the period 1974—1976 will be surveyed in Volume 7.

Comments on the presentation of the alkaloid reports are welcome, and reporters will appreciate receiving reprints of articles, particularly those published in less accessible journals. I wish to express my gratitude to the new contributors as well as to the old hands for the accuracy and prompt dispatch of manuscripts, and to Dr. Saxton for his indispensable advice.

March 1976

M. F. GRUNDON

Contents

Chapter 1 Biosynthesis	1
<i>By R. B. Herbert</i>	
1 Introduction	1
2 Piperidine, Pyridine, and Pyrrolidine Alkaloids	1
Piperidine Alkaloids (General)	1
Anatabine and Anabasine	2
Lobeline	3
Santiaguine	5
Quinolizidine Alkaloids	6
<i>N</i> -Methylconiine	7
Ricinine	7
Tropane Alkaloids	8
Pyrrolizidine Alkaloids	11
Nicotine	13
3 Isoquinoline Alkaloids	15
Cryptostyline	15
Cactus Alkaloids	16
<i>Papaver</i> Alkaloids	17
Aporphine Alkaloids	19
Protopine	22
Corydaline and Ochotensimine	23
<i>Erythrina</i> Alkaloids	25
Hasubanonine and Protostephanine	26
Cephalotaxine	27
Colchicine	28
4 Alkaloids Derived from Tryptophan	29
Echinulin	29
Sporidesmin	30
Cyclopiazonic Acid	30
Ergot	31
Gramine	33
Terpenoid Indole Alkaloids	33
Camptothecin	36
5 Miscellaneous Bases of Aromatic Origin	37
Gliotoxin and Mycelianamide	37
Amaryllidaceae Alkaloids	39

	Furoquinoline Alkaloids	39
	Securinine	40
	Betalains	41
	Demethyltomaymycin	41
	Actinomycin	42
	Cytochalasins	44
	6 Miscellaneous Bases of Aliphatic Origin	45
	Mitomycin and Rifamycin	45
	Penicillin	49
	Prodigiosins	50
	Steroidal Alkaloids	52
Chapter 2	Pyrrolidine, Piperidine, and Pyridine Alkaloids	54
	<i>By A. R. Pinder</i>	
	1 Pyrrolidine Alkaloids	54
	<i>Dendrobium</i> Alkaloids	54
	2 Piperidine Alkaloids	56
	Spiropiperidine Alkaloids	58
	Decahydroquinoline Alkaloids	59
	Bispiperidine Alkaloids	59
	3 Pyridine Alkaloids	62
Chapter 3	Tropane Alkaloids	65
	<i>By G. Fodor</i>	
	1 Occurrence, and Structures of New Alkaloids	65
	2 Synthetic Chemical and Pharmacological Studies	67
	3 Analysis	70
Chapter 4	The Pyrrolizidine Alkaloids	72
	<i>By D. H. G. Crout</i>	
	1 Introduction	72
	2 The Necine Bases	72
	3 The Ester Alkaloids	73
	4 X-Ray Studies	80
	5 General Studies	81
	6 Pharmacological Studies	84

<i>Contents</i>	vii
Chapter 5 Indolizidine Alkaloids	86
<i>By J. A. Lambertson</i>	
1 <i>Elaeocarpus</i> Alkaloids	86
2 Pharaoh Ant Trail Pheromone	86
3 Alkaloids of <i>Tylophora</i> Species	88
Chapter 6 The Quinolizidine Alkaloids	90
<i>By M. F. Grundon</i>	
1 The Cytisine–Lupanine–Sparteine–Matrine Group and the <i>Ormosia</i> Alkaloids	90
Occurrence	90
Spectroscopic and Chemical Studies	91
Structural Studies	93
2 Sesquiterpenoid Alkaloids from <i>Nuphar</i> Species	94
3 Lythraceae Alkaloids	96
4 Cryptopleurine	98
5 9b-Azaphenalene Alkaloids	99
Chapter 7 Quinoline, Quinazoline, and Acridone Alkaloids	103
<i>By M. F. Grundon</i>	
1 Quinoline Alkaloids	103
Isolation and Detection	103
Quinoline Alkaloids without 3-Substituents	105
Furoquinoline Alkaloids	105
3-Prenylquinoline Alkaloids	107
2 Quinazoline Alkaloids	108
3 Acridone Alkaloids	108
Chapter 8 β-Phenethylamines and the Isoquinoline Alkaloids	110
<i>By N. J. McCorkindale</i>	
1 General	110
2 β-Phenethylamine Alkaloids	111
3 Simple Isoquinoline Alkaloids	117
4 Benzyloisoquinoline Alkaloids	123
5 Pavine Alkaloids	128

6 Dibenzopyrrocoline Alkaloids	130
7 Morphine Alkaloids	131
8 Colchicine Alkaloids	139
9 Cularine Alkaloids	141
10 Protoberberine Alkaloids	141
11 Protopine Alkaloids	148
12 Benzophenanthridine Alkaloids	150
13 Phthalideisoquinoline Alkaloids	154
14 Rhoeadine and Papaverrubine Alkaloids	158
15 Spirobenzylisoquinoline Alkaloids	160
16 Ipecacuanha Alkaloids	162
17 Dimeric Benzylisoquinoline Alkaloids	164
Chapter 9 The Aporphinoids	
<i>By M. Shamma</i>	170
1 Introduction	170
2 Proaporphines	170
3 Aporphines	171
4 Proaporphine- and Aporphine-Benzylisoquinoline Dimers	179
5 Aporphine-Pavine Dimers	181
6 Oxoaporphines	181
7 Dioxoaporphines, Aristolactams, and Aristolochic Acids	183
8 Phenanthrenes	186
9 Azaffluoranthenes	187
Chapter 10 Indole Alkaloids	189
<i>By J. E. Saxton</i>	
1 Introduction	189
2 Simple Alkaloids	190
Non-tryptamines	190
Non-isoprenoid Tryptamines	191

3 Isoprenoid Tryptamine and Tryptophan Alkaloids	196
Mould Metabolites	196
Ergot Alkaloids	199
Monoterpenoid Alkaloids	202
Corynantheine–Heteroyohimbine–Yohimbine Group, and Related Oxindoles	202
Sarpagine–Ajmaline–Picraline Group	220
Strychnine–Akuammicine–Condylocarpine– Ellipticine Group	225
Aspidospermine–Aspidofractine–Eburnamine Group	230
Ibogamine–Cleavamine Group	241
4 Biogenetically Related Quinoline Alkaloids	243
5 Bis-indole Alkaloids	246
Chapter 11 <i>Lycopodium</i> Alkaloids By W. A. Ayer	252
Chapter 12 Diterpenoid Alkaloids By S. W. Pelletier and S. W. Page	256
1 Introduction	256
2 C₁₉ Diterpenoid Alkaloids	257
Acomonine	257
Iliensine	258
Delphisine	258
Neoline, Chasmanine, and Homochasmanine	258
Deoxydelcorine	259
Excelsine	260
Veratroylpseudaconine and Diacetylpseudaconitine	261
3 C₂₀ Diterpenoid Alkaloids	262
Vakognavine	262
Miyaconitine and Miyaconitinone	263
Rearrangements	264
Atisine–Lycoctonine Conversion	264
Veatchine Skeletal Rearrangement	265
Synthetic Studies	267
4 <i>Daphniphyllum</i> Alkaloids	267
Daphniteijsmine	267
Daphnijsmine and Desacetyldaphnijsmine	268
Daphniteijsmanine	268
Yuzurine	268

Daphniphylline	270
Methyl Homodaphniphyllate	270
Daphnilactone-B	271
Chapter 13 Steroidal Alkaloids of the Apocynaceae, Buxaceae, Asclepiadaceae, and of the <i>Salamandra-Phyllobates</i> Group By <i>F. Khuong-Huu and R. Goutarel</i>	272
1 Alkaloids of the Apocynaceae	272
Steroidal Alkaloids and Amines	272
Synthesis, Reactions, and Transformations of Steroidal Amines	272
Photochemistry	280
N. M. R. Spectra	280
2 Alkaloids of the Asclepiadaceae	280
3 <i>Salamandra</i> Alkaloids	281
4 <i>Buxus</i> Alkaloids	282
5 Biological Notes	283
Chapter 14 <i>Solanum</i> and <i>Veratrum</i> Steroidal Alkaloids By <i>D. M. Harrison</i>	285
1 <i>Solanum</i> Alkaloids	285
2 <i>Veratrum</i> Alkaloids	290
Erratum	296
Author Index	297

1 Introduction

The number of papers appearing on alkaloid biosynthesis continues to be large. In reviewing this work the practice of referring to previous Reports is continued and, in order to make this background material more conveniently accessible, these Reports are listed as references 1—5. Access to work reported before 1969 is most easily gained through two excellent and comprehensive reviews^{6,7} and reference is made to these where appropriate. The reader is also recommended to consult the alternative annual survey on alkaloid biosynthesis,⁸ where the approach is different from the one adopted here.

2 Piperidine, Pyridine, and Pyrrolidine Alkaloids

Piperidine Alkaloids (General).—As part of a study of the role of cadaverine (1) in the biosynthesis of piperidine alkaloids samples of (1), stereospecifically labelled with tritium at C-1, were tested as precursors for *N*-methylpelletierine (2).⁹ These samples were prepared by decarboxylation of L-lysine through the action of L-lysine

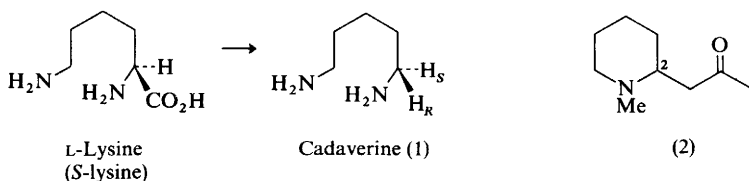

- 1 R. B. Herbert, in 'The Alkaloids', ed. J. E. Saxton (Specialist Periodical Reports), The Chemical Society, London, 1971, Vol. 1.
- 2 J. Staunton, in 'The Alkaloids', ed. J. E. Saxton (Specialist Periodical Reports), The Chemical Society, London, 1972, Vol. 2.
- 3 R. B. Herbert, in 'The Alkaloids', ed. J. E. Saxton (Specialist Periodical Reports), The Chemical Society, London, 1973, Vol. 3.
- 4 R. B. Herbert, in 'The Alkaloids', ed. J. E. Saxton (Specialist Periodical Reports), The Chemical Society, London, 1974, Vol. 4.
- 5 R. B. Herbert, in 'The Alkaloids', ed. J. E. Saxton (Specialist Periodical Reports), The Chemical Society, London, 1975, Vol. 5.
- 6 'Biosynthese der Alkaloide', ed. K. Mothes and H. R. Schütte, VEB Deutscher Verlag der Wissenschaften, Berlin, 1969.
- 7 I. D. Spenser, in 'Comprehensive Biochemistry', ed. M. Florin and E. H. Stotz, Elsevier, Amsterdam, 1968, Vol. 20, p. 231.
- 8 E. Leete, in 'Biosynthesis', ed. T. A. Geissman (Specialist Periodical Reports), The Chemical Society, London, 1972—1975, Vols. 1—3.
- 9 E. Leistner and I. D. Spenser, *J. Amer. Chem. Soc.*, 1973, **95**, 4715; R. B. Herbert, in ref. 5, p. 5.

decarboxylase (isolated from *Bacillus cadaveris*). Although this reaction was known to proceed stereospecifically¹⁰ it was not known at the time if the result was retention or inversion of configuration. It has recently been shown,¹¹ however, that the consequence of the enzymic decarboxylation is retention of configuration, and so [1A-³H]cadaverine⁹ is (1R)-[1-³H]cadaverine. It follows then, from the earlier conclusion⁹ about cadaverine incorporation into *N*-methylpelletierine (2), that it is the 1-*pro-R* proton from cadaverine (1) which is retained at C-2 of (2) and the 1-*pro-S* hydrogen atom which is lost.

Anatabine and Anabasine.—Although the biosynthetic pathway to anabasine (3) has been delineated in detail,^{12,13} little evidence had been obtained until recently on the way in which anatabine (8) is formed: [2-¹⁴C]lysine and [2-¹⁴C]-4-hydroxylysine were found not to label anatabine¹⁴ and results with ¹⁴CO₂ indicated that anabasine was not a precursor of anatabine.¹⁵

In a recent study,¹⁶ [2-¹⁴C]lysine was fed to *Nicotiana glutinosa*, and although it was specifically incorporated into anabasine (3) in the expected manner it did not label the anatabine (8), thus according with the previous result.¹⁴

Nicotinic acid (6) is well established as a precursor of the pyridine ring of nicotine^{13,17} and is also a precursor of this moiety in anabasine.^{13,18} [6-¹⁴C]Nicotinic acid, as might therefore be expected, gave radioactive anatabine, but surprisingly the activity was divided equally between C-6 and C-6' ([*carboxy*-¹⁴C]nicotinic acid failed to label any of the alkaloids significantly).¹⁶ It follows that nicotinic acid (6) is the source for both rings of anatabine and the equal distribution of label indicates that the two units from which the alkaloid is formed are closely related, if not identical.

The manner in which the two nicotinic acid units may be joined (Scheme 1) is suggested¹⁶ by analogy with the probable intermediacy of a dihydronicotinic acid in nicotine biosynthesis.¹⁷ It is further suggested that anatabine (4) and nicotelline (5) are trimers of the dihydro-derivative (7).¹⁶

The anabasine obtained after feeding [6-¹⁴C]nicotinic acid was found to be labelled almost exclusively in the pyridine ring, so no significant conversion of anatabine (8) into anabasine (3) occurs.¹⁶

In accord with previous conclusions^{12,13} about the relationship between lysine and anabasine (3), lysine has been found to be a precursor for (3) in *Anabasis aphylla* along a pathway which does not involve symmetrical intermediates.¹⁹ Aspartic acid was found to serve as a precursor for both rings of anabasine²⁰ whilst lysine was incorporated into lupinine,¹⁹ again in accord with previous results.

¹⁰ S. Mandeles, R. Koppelman, and M. E. Hanke, *J. Biol. Chem.*, 1954, **209**, 327.

¹¹ E. Leistner and I. D. Spenser, *J.C.S. Chem. Comm.*, 1975, 378.

¹² R. B. Herbert, in ref. 5, p. 5; ref. 4, p. 4.

¹³ (a) D. Gross, in ref. 6, p. 234; (b) I. D. Spenser, in ref. 7, p. 253.

¹⁴ T. Kisaki, S. Mizusaki, and E. Tamaki, *Phytochemistry*, 1968, **7**, 323.

¹⁵ W. L. Alworth and H. Rapoport, *Arch. Biochem. Biophys.*, 1965, **112**, 45.

¹⁶ E. Leete, *J.C.S. Chem. Comm.*, 1975, 9.

¹⁷ R. B. Herbert in ref. 4, p. 7 and refs. cited.

¹⁸ M. L. Solt, R. F. Dawson, and D. R. Christman, *Plant Physiol.*, 1960, **35**, 887.

¹⁹ M. Y. Lovkova, E. I. Nurimov, and G. S. Il'in, *Biokhimiya*, 1974, **39**, 388 (*Chem. Abs.*, 1974, **81**, 132882).

²⁰ M. Y. Lovkova, E. I. Nurimov, and G. S. Il'in, *Biokhimiya*, 1974, **39**, 523 (*Chem. Abs.*, 1974, **81**, 166429).

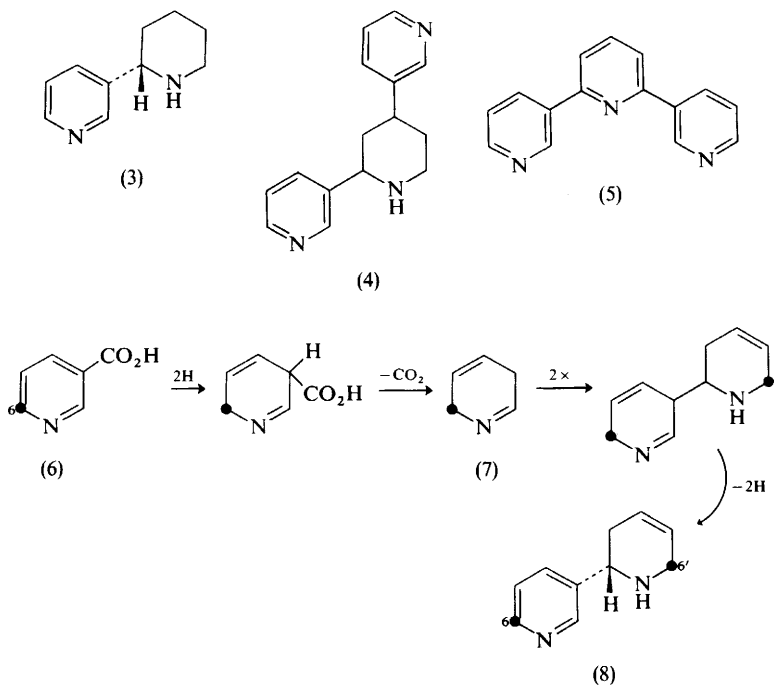

Scheme 1

Lobeline.—The results of feeding experiments with DL-[2-¹⁴C]lysine and DL-[2-¹⁴C]phenylalanine in *Lobelia inflata* have shown that these amino-acids are both specific precursors for the alkaloid lobeline (13).^{21,22} In further experiments, DL-[3-¹⁴C]phenylalanine, [3-¹⁴C]cinnamic acid, and [3-¹⁴C]-3-hydroxy-3-phenylpropionic acid [as (9)] have been found to be specific precursors for lobeline (13).²³ These results are consistent with the anticipated pathway²⁴ to lobeline illustrated in Scheme 2, with benzoylacetic acid (10) as the intermediate which couples with Δ¹-piperidine to give the intermediate (11). The probability of 3-hydroxy-3-phenylpropionic acid (9) being an intermediate in lobeline biosynthesis is increased by the isolation of this acid from *L. inflata*.²⁵

In contrast to the biosynthesis of many other piperidine alkaloids, the incorporation of [2-¹⁴C]lysine into lobeline (13) was found to be symmetrical, *i.e.* C-2 and C-6 were equally labelled. Symmetrization of the label could occur on formation of lobelanine (12), a known late precursor,^{22,26} or at a possible earlier intermediate,

²¹ M. F. Keogh and D. G. O'Donovan, *J. Chem. Soc. (C)*, 1970, 2470.

²² R. B. Herbert, in ref. 3, p. 27.

²³ D. G. O'Donovan, D. J. Long, E. Forde, and P. Geary, *J.C.S. Perkin I*, 1975, 415.

²⁴ Cf. M. H. Zenk, in 'Biosynthesis of Aromatic Compounds', Proceedings of the 2nd meeting of F.E.B.S., ed. G. Billek, Pergamon Press, Oxford, Vol. 3, 1966, p. 45; M. H. Zenk, in 'Pharmacognosy and Phytochemistry', ed. H. Wagner and L. Hörhammer, Springer-Verlag, Berlin, 1971, p. 314; R. N. Gupta and I. D. Spenser, *Canad. J. Chem.*, 1967, **45**, 1275.

²⁵ H. Wieland, W. Koschara, E. Dane, J. Renz, W. Schwarze, and W. Linde, *Annalen*, 1939, **540**, 103.

²⁶ D. G. O'Donovan and T. Forde, *J. Chem. Soc. (C)*, 1971, 2889.

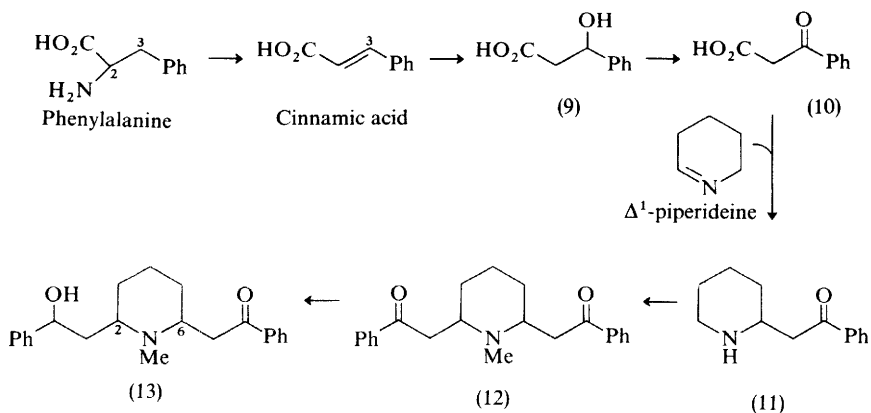

Scheme 2

cadaverine (1). Cadaverine was found, however, to be a much less efficient precursor for lobeline than lysine or Δ^1 -piperidine, which argues strongly that it is not an obligatory intermediate in lobeline biosynthesis (*cf.* the discussion on piperidine alkaloid biosynthesis in ref. 12) and thus symmetrization of lysine label occurs *via* lobelanine (12).

The biosynthesis of *Lobelia* alkaloids with C_4 units at C-2 and C-6 can be accounted for in terms of the pathway shown in Scheme 3,²³ in which it is envisaged

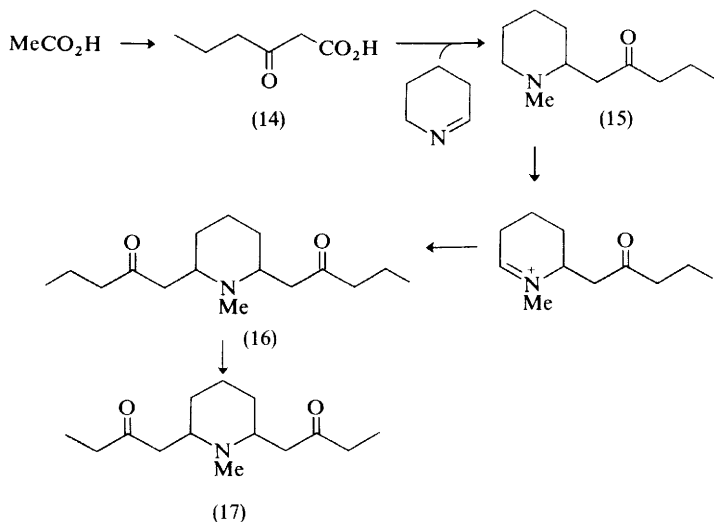

Scheme 3

that acetate-derived 3-oxohexanoic acid (14) condenses with Δ^1 -piperidine to afford, after methylation, the keto-amine (15) which is oxidized and condensed with a further molecule of 3-oxohexanoic acid (14). Truncation of the (16) formed affords

the alkaloid (17). Evidence for the validity of this pathway has been adduced from the results of feeding $[2-^{14}\text{C}]$ lysine and $[1-^{14}\text{C}]$ acetate.²³ The former precursor provides the piperidine ring of (17) as expected and acetate the side chains, with one half of the activity on the carbonyl groups as required by the hypothesis.

Santiaguine.—The origin of the curious α -truxillic acid (18) moiety of santiaguine (21), an alkaloid of *Adenocarpus* species, has been shown to be cinnamic acid. This moiety arises, the available evidence has suggested, during the biosynthesis of santiaguine as a result of the dimerization of adenocarpine (20).²⁷ An alternative route to santiaguine, which involves the dimerization of cinnamic acid, followed by condensation of the α -truxillic acid formed with tetrahydroanabasine (19), had not been explored, however. Recent results²⁸ demonstrate that α -truxillic acid (18) exists free in *Adenocarpus foliosus*, is specifically labelled by cinnamic acid, and is itself specifically incorporated into santiaguine (21). Thus two distinct pathways to santiaguine may operate (Scheme 4) but it appears, from the relative incorporation efficiencies, that the route *via* adenocarpine (20) is, at least, the major one.

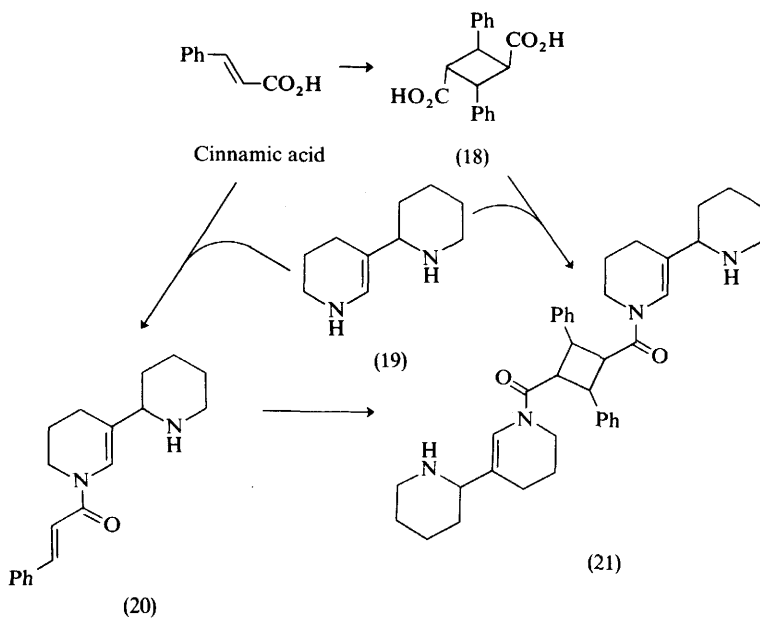

Scheme 4

α -Truxillic acid (18) can be formed photochemically *in vitro*, from cinnamic acid,²⁹ but it seems that such a route is not operative *in vivo*, for no significant difference in the incorporation of labelled adenocarpine (20) into santiaguine (21) could be observed with plants grown in light or darkness.²⁸

²⁷ D. G. O'Donovan and P. B. Creedon, *J. Chem. Soc. (C)*, 1971, 1604; R. B. Herbert in ref. 3, p. 27.

²⁸ D. G. O'Donovan and P. B. Creedon, *J.C.S. Perkin I*, 1974, 2524.

²⁹ H. I. Bernstein and W. C. Quimby, *J. Amer. Chem. Soc.*, 1943, **65**, 1845; E. H. White and H. C. Dunathan, *ibid.*, 1956, **78**, 6055.

The origins of the tetrahydroanabasine (19) moieties of santiaguine have been examined in feeding experiments with DL-[2-¹⁴C]- and DL-[6-¹⁴C]-lysine. Tracer was incorporated specifically and unsymmetrically into each of the heterocyclic rings (Scheme 5). Labeled Δ^1 -piperideine (22) was incorporated in like manner and is thus a likely intermediate in the formation of each piperidine ring (Scheme 5). These results are in accord with the carefully delineated pattern of piperidine alkaloid

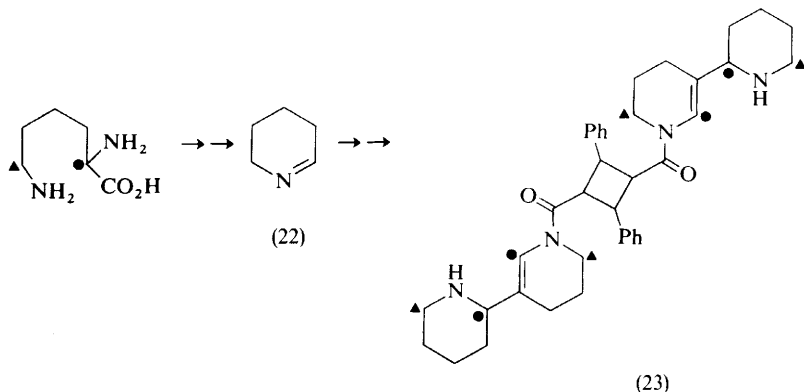

Scheme 5

biosynthesis.^{9,12,13,30} Application of the model developed⁹ to explain the incorporation of lysine and cadaverine into these alkaloids allows one to include cadaverine as a precursor for santiaguine, as the tracer results suggest.³¹ [The generation of the tetrahydroanabasine skeleton of (21) from lysine makes a notable contrast with the formation of anatabine (8) from nicotinic acid; see above].

The above experiments have thrown up a point of practical interest and possible application elsewhere. When radioactive Δ^1 -piperideine was fed to *A. foliosus* followed by labelled cinnamic acid, the incorporation of the latter was 10 times as high as previously found. This was tentatively attributed to stimulation of alkaloid biosynthesis by the presence of both precursors necessary for alkaloid synthesis.²⁸

Quinolizidine Alkaloids.—Previous results demonstrate that the quinolizidine skeleton in its entirety derives from lysine.³² Further research has indicated that lysine is a precursor of all the alkaloids of this type in five species of Leguminosae.³³ From the levels of activity observed in the individual alkaloids it was concluded that saturated alkaloids are precursors for those with a pyridone ring. This was supported by the observation³⁴ that label from radioactive sparteine (24) and lupanine (25) appeared in more highly oxidized alkaloids. (This compares with a similar situation in the biosynthesis of matrine-type alkaloids.³⁵) A metabolic grid for the biosynthesis of quinolizidine alkaloids from lysine was proposed,³⁶ based on these results,

³⁰ R. B. Herbert, in ref. 1, p. 4; ref. 3, p. 25; ref. 4, p. 1; J. Staunton, in ref. 2, p. 20 and refs. cited.

³¹ H. R. Schütte, K. L. Kelling, D. Knöfel, and K. Mothes, *Phytochemistry*, 1964, **3**, 249.

³² I. D. Spenser, in ref. 7, p. 262; H. R. Schütte, in ref. 6, p. 324.

³³ E. K. Nowacki and G. R. Waller, *Phytochemistry*, 1975, **14**, 155.

³⁴ E. K. Nowacki and G. R. Waller, *Phytochemistry*, 1975, **14**, 161.

³⁵ A. A. Takanaev, *Khim. Rast. Veshchetv.*, 1972, 31 (*Chem. Abs.*, 1973, **79**, 765).

³⁶ E. K. Nowacki and G. R. Waller, *Phytochemistry*, 1975, **14**, 165.

other more convincing evidence,^{32,37,38} and the taxonomical distribution of quinolizidine alkaloids.

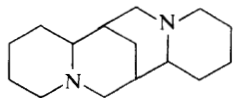

(24)

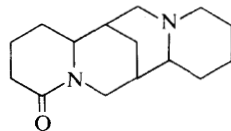

(25)

In young *Lupinus nanus* plants added cadaverine but not putrescine or hexamethylenediamine lowered the incorporation of lysine into thermopsine (26). (In flowering plants the difference between cadaverine and the other two diamines was less marked.³³) These results provide further evidence for the intermediacy of cadaverine in quinolizidine biosynthesis.^{32,38,39}

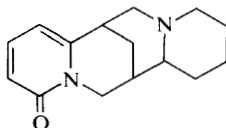

(26)

N-Methylconiine.—Feeding experiments with L-[Me-¹⁴C]methionine in *Conium maculatum* varieties have established that the methyl group of methionine serves as the source of the N-methyl group of methylconiine (27).⁴⁰ This adds further to the picture of coniine biosynthesis⁴¹ and provides an additional example of transmethylation in plants. In further experiments,⁴² an enzyme was isolated from *C. maculatum* that was capable of catalysing the transfer of a methyl group from S-adenosylmethionine to coniine (28), with the formation of N-methylconiine (27). The enzyme was partially purified and characterized in part.

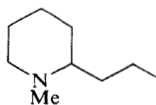

(27)

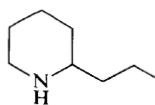

(28)

Ricinine.—Quinolinic acid (29) is known to be a precursor of ricinine (32).^{43,44} The results of other studies have indicated that the pyridine nucleotide cycle (Scheme 6)

³⁷ Y. D. Cho and R. O. Martin, *Canad. J. Biochem.*, 1971, **49**, 971.

³⁸ R. B. Herbert, in ref. 3, p. 30.

³⁹ B. A. Abdusalamov, A. A. Takanaev, Kh. A. Aslanov, and A. S. Sadykov, *Biochemistry (U.S.S.R.)*, 1971, **36**, 239.

⁴⁰ M. F. Roberts, *Phytochemistry*, 1974, **13**, 1841.

⁴¹ E. Leete and J. O. Olson, *J. Amer. Chem. Soc.*, 1972, **94**, 5472; E. Leete, *ibid.*, 1964, **86**, 2509; M. F. Roberts, *Phytochemistry*, 1971, **10**, 3057; R. B. Herbert, in ref. 4, p. 10; ref. 1, p. 1; J. Staunton, in ref. 2, p. 26.

⁴² M. F. Roberts, *Phytochemistry*, 1974, **13**, 1847.

⁴³ K. S. Yang and G. R. Waller, *Phytochemistry*, 1965, **4**, 881.

⁴⁴ L. A. Hadwiger, S. E. Badiel, G. R. Waller, and R. K. Gholson, *Biochem. Biophys. Res. Comm.*, 1963, **13**, 466.

may be a necessary part of ricinine biosynthesis,^{45,46} although the observed⁴⁷ increase in incorporation of label into ricinine from radioactive quinolinic acid in the presence of excess exogenous NAD⁺ has been interpreted as indicating that conversion of quinolinic acid (29) into ricinine occurs by a separate pathway.⁴⁷ In order to clarify the relationship of the pyridine nucleotide cycle (Scheme 6) to ricinine biosynthesis the effect of various inhibitors on quinolinic acid incorporation into ricinine and pyridine nucleotide cycle intermediates has been examined.⁴⁸

Azaserine, a glutamine antagonist,⁴⁹ is known to inhibit the NAD⁺ synthetase reaction in which nicotinic acid adenine dinucleotide is converted into NAD⁺ with glutamine or ammonia as the nitrogen donor.^{50,51} When azaserine or azaleucine was fed to *Ricinus communis* plants followed by [6-¹⁴C]quinolinic acid, a marked decrease in incorporation of radioactivity into ricinine was observed with azaleucine, less so with azaserine.⁴⁸ Both azaserine and azaleucine were found also to inhibit the incorporation of [6-¹⁴C]quinolinic acid into pyridine nucleotide cycle intermediates [in the case of azaserine the conversion of nicotinic acid dinucleotide into nicotinamide adenine dinucleotide (NAD⁺) was apparently inhibited].

Ricinine and ethionine were found to inhibit ricinine biosynthesis with shunting of radioactivity from [6-¹⁴C]quinolinic acid through the pyridine nucleotide cycle into *N*-methylnicotinic acid (30) and *N*-methylnicotinamide (31) (*cf.* Scheme 6), and quinolinic acid consumption was reduced.

These results strongly indicate a dependency between ricinine biosynthesis and the pyridine nucleotide cycle. The similarity in incorporation of members of this cycle into ricinine⁴⁵ is explained by allowing each member to be diverted directly into a pathway leading to ricinine; this explanation covers the observation that excess exogenous NAD⁺ increases the incorporation of quinolinic acid into ricinine⁴⁷ since this precursor can simply be shunted along one of these diversions if the formation of NAD⁺ is blocked by its presence in large excess.

Tropane Alkaloids.—An abundance of evidence points to phenylalanine as an intermediate in the biosynthesis of the tropic acid moiety [as (34)] of tropane alkaloids like atropine (33),^{52,53} but support has also been obtained for alternative precursors for this moiety.^{53,54} All nine of the carbon atoms of phenylalanine are incorporated into tropic acid (Scheme 7)^{52,53} in a rearrangement reaction which

⁴⁵ G. R. Waller, K. S. Yang, R. K. Gholson, A. L. Hadwiger, and S. Chaykin, *J. Biol. Chem.*, 1966, **241**, 4411.

⁴⁶ E. Leete and F. H. B. Leitz, *Chem. and Ind.*, 1957, 1572.

⁴⁷ R. A. Hiles and R. U. Byerrum, *Phytochemistry*, 1969, **8**, 1927.

⁴⁸ R. D. Johnson and G. R. Waller, *Phytochemistry*, 1974, **13**, 1493.

⁴⁹ B. Levenberg, I. Melnick, and J. M. Buchanan, *J. Biol. Chem.*, 1957, **225**, 163.

⁵⁰ T. A. Langman, jun., N. O. Kaplan, and L. Shuster, *J. Biol. Chem.*, 1959, **234**, 2161; S. A. Narrod, V. Bonavita, E. R. Ehrenfeld, and N. O. Kaplan, *J. Biol. Chem.*, 1961, **236**, 931; T. F. Slater and B. C. Sawyer, *Biochem. Pharmacol.*, 1966, **15**, 1267; N. Bonasera, G. Mangione, and V. Bonavita, *ibid.*, 1963, **12**, 633.

⁵¹ J. Priess and P. Handler, *J. Biol. Chem.*, 1958, **233**, 488.

⁵² E. Leete, *J. Amer. Chem. Soc.*, 1960, **82**, 612; E. W. Underhill and H. W. Youngken, jun., *J. Pharm. Sci.*, 1962, **51**, 121; D. Gross and H. R. Schütte, *Arch. Pharm.*, 1963, **296**, 1; E. Leete and M. L. Loudon, *Chem. and Ind.*, 1961, 1405; M. L. Loudon and E. Leete, *J. Amer. Chem. Soc.*, 1962, **84**, 1510, 4507; C. A. Gibson and H. W. Youngken, jun., *J. Pharm. Sci.*, 1967, **56**, 854.

⁵³ H. W. Liebisch, in ref. 6, p. 183.

⁵⁴ R. B. Herbert, in ref. 4, p. 13 and refs. cited.

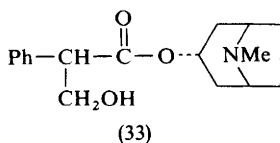
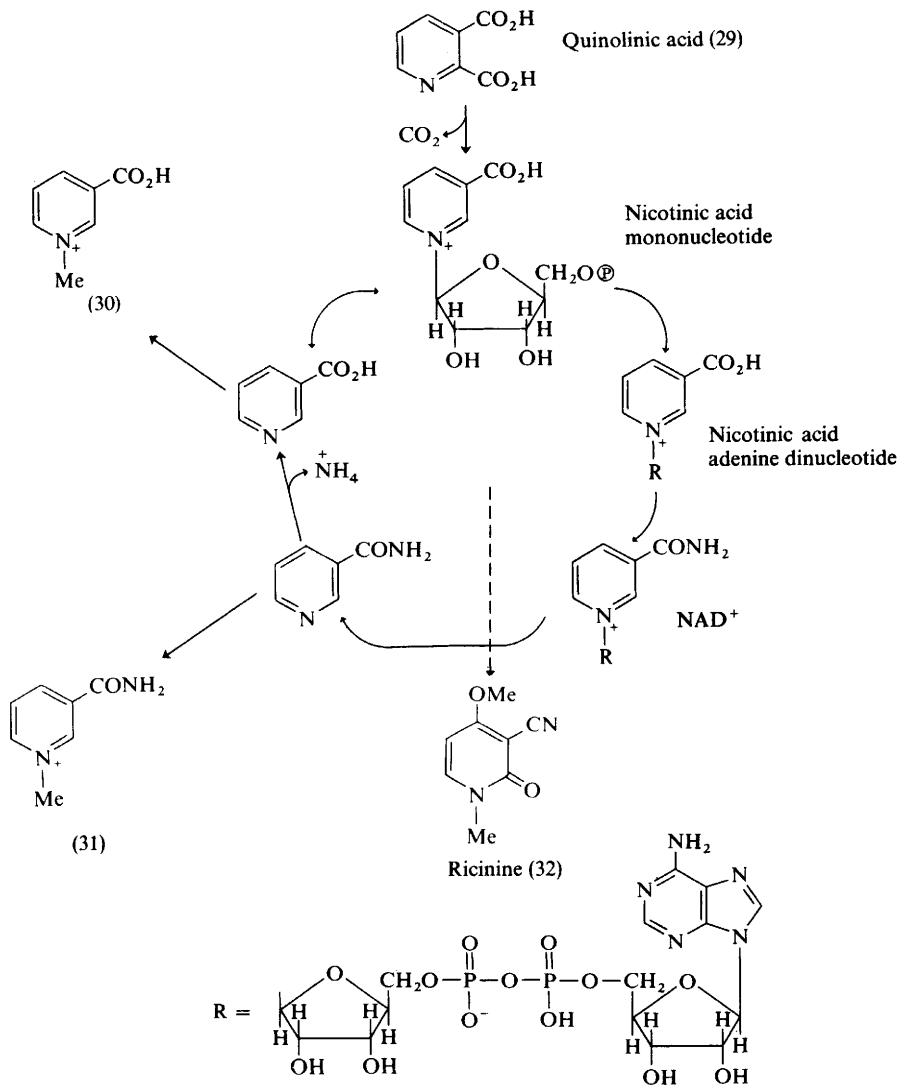

manifestly involves the migration of the carboxy-group rather than the phenyl group. The mechanism of the rearrangement is unknown, but it is circumscribed to some extent by the results of other experiments.

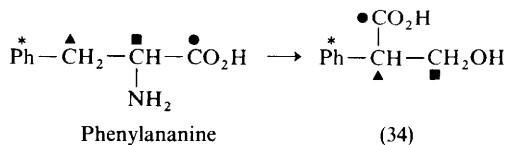

Scheme 7

Phenylpyruvic acid (36) has been found to be a similarly efficient precursor for tropic acid as phenylalanine,^{55,56} but the ready interconversion of phenylalanine and (36) *in vivo* makes it difficult to say which is closer biosynthetically to tropic acid. Phenyl-lactic acid (37), as it appears in the alkaloid littorine (35), is known to be derived from phenylalanine,^{57,58} and it was found to be a better precursor than phenylalanine for the tropic acid moiety of tropane alkaloids.^{56,58}

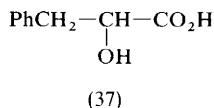
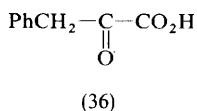
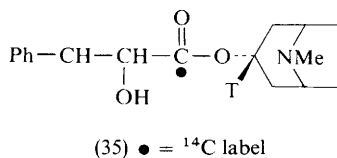

Cinnamic acid, a metabolite of phenylalanine, has been linked with tropic acid biosynthesis *via* its epoxide (38) on chemical grounds, but neither of these compounds was found to act as a tropic acid precursor.^{56,58,59} That rearrangement was not taking place after linking cinnamic acid to a tropine residue was demonstrated when it was found that cinnamoyltropine (40; ¹⁴C labels as shown) was incorporated into (33) with retention only of the tropine label, which is consistent with hydrolysis of (40) to tropine (39) and cinnamic acid in the plant, the latter not being incorporated.⁶⁰ Moreover, whilst littorine (35; ¹⁴C and ³H labels as shown) was incorporated specifically into atropine (33), the change in isotope ratio demonstrated that incorporation involved prior hydrolysis of littorine to tropine (39) and phenyl-lactic acid;⁶⁰ no facile interconversion between tropine, tropic acid, and littorine was apparent because the littorine isolated at the end of the experiment showed the same isotope ratio as the material fed. Thus rearrangement of a tropine ester of lactic acid is not involved in the rearrangement to give tropic acid either.

⁵⁵ H. W. Liebisch, G. C. Bhavsar, and H. J. Schaller, in 'Biochemie und Physiologie der Alkaloide', Fourth International Symposium, 1969, ed. K. Mothes, K. Schreiber, and H. R. Schütte, Akademie-Verlag, Berlin, p. 233.

⁵⁶ H. W. Liebisch, Abstracts of the Seventh International Symposium on the Chemistry of Natural Products, Riga, U.S.S.R., 1970, p. 557; quoted in ref. 60.

⁵⁷ W. C. Evans and V. A. Woolley, *Phytochemistry*, 1969, **8**, 2183.

⁵⁸ W. C. Evans, J. G. Woolley, and V. A. Woolley, in ref. 55, p. 227.

⁵⁹ E. Leete and J. D. Braunstein, unpublished work; quoted in ref. 60.

⁶⁰ E. Leete and E. P. Kirven, *Phytochemistry*, 1974, **13**, 1501.

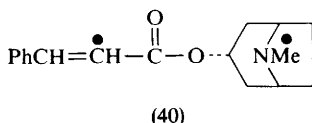
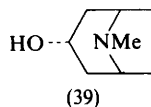
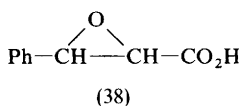

In *Datura* species the tigloyl moiety [as (41)] of *e.g.* meteloidine (42) is known to arise from L-isoleucine *via* 2-methylbutanoic acid,⁶¹ and although angelic acid (44) is also derived from L-isoleucine⁶² it is not a precursor for tropane alkaloids in *Datura innoxia*, and so no *cis-trans* isomerization of (44) to (41) occurs in this plant.⁶³ In further experiments L-[¹⁴C]isoleucine has been found to give radioactive tigloidine (45) and 3 α -tigloyloxytropane (43) in *Physalis peruviana*⁶⁴ and radioactive (46) in *D. ceratocaula*;⁶⁵ in the case of (46) the radioactivity was shown to be confined to the 2-methylbutanoyl moiety, which notably is of the same configuration as L-isoleucine.

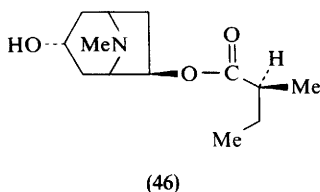
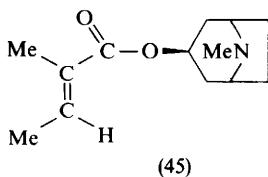
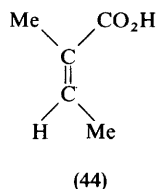
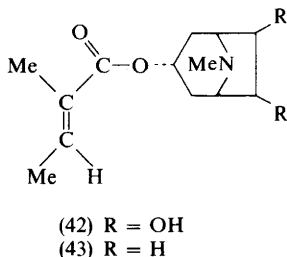
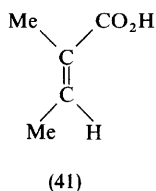

Pyrrolizidine Alkaloids.—The C₁₀ necic acids of the senecic acid type, which appear as diesters in alkaloids like senecionine (47), have been shown to be formed from two units of L-isoleucine as illustrated in Scheme 8.⁶⁶ Further experiments have shown

⁶¹ J. G. Woolley, *Abhandl. Deut. Akad. Wiss. Berlin, Klasse Chem. Geol. Biol.*, 1966, No. 3, p. 531; E. Leete and J. B. Murrill, *Tetrahedron Letters*, 1967, 1727; K. Basey and J. G. Woolley, *Phytochemistry*, 1973, **12**, 2197; E. Leete, *Phytochemistry*, 1973, **12**, 2203; R. B. Herbert, in ref. 5, p. 12.

⁶² D. H. G. Crout, *J. Chem. Soc. (C)*, 1967, 1233.

⁶³ K. Basey and J. G. Woolley, *Phytochemistry*, 1973, **12**, 2883.

⁶⁴ P. J. Beresford and J. G. Woolley, *Phytochemistry*, 1974, **13**, 2143.

⁶⁵ P. J. Beresford and J. G. Woolley, *Phytochemistry*, 1974, **13**, 2511.

⁶⁶ D. H. G. Crout, N. M. Davies, E. H. Smith, and D. Whitehouse, *J.C.S. Perkin I*, 1972, 671; R. B. Herbert, in ref. 3, p. 40; ref. 1, p. 8.

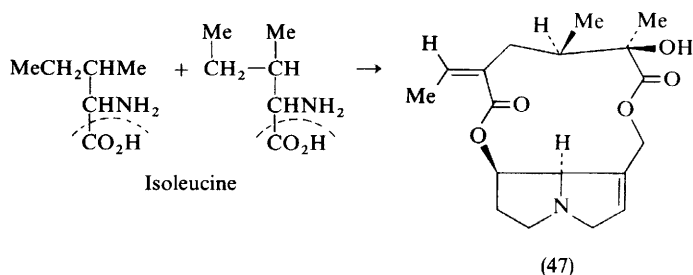

Scheme 8

that, of the four stereoisomers of isoleucine, only L-isoleucine is used efficiently for senecionine biosynthesis in *Senecio magnificus* plants⁶⁷ (of the other isomers only L-alloisoleucine is significantly incorporated, but it has still to be established whether this incorporation is specific or not). This selection of one particular isomer of isoleucine for biosynthesis contrasts with the finding that certain micro-organisms can use the different stereoisomers of this amino-acid for growth⁶⁸ and biosynthesis.⁶⁹

Acetate has been reported to be a precursor for the necic acid component, monocrotalic acid [as (48)], of monocrotaline (49).⁷⁰ Rigorous attempts to confirm this finding have met only with failure.⁷¹ Although acetate was rapidly taken up into the plant it was not incorporated into (49). The earlier conclusion, it was suggested, may have been occasioned by working with impure alkaloid.

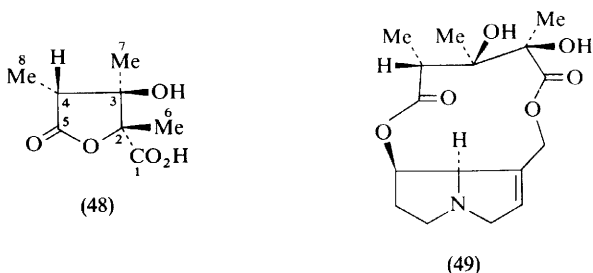

A more reasonable genesis of monocrotalic acid, at least as far as C-1, -2, -3, -6, and -7 are concerned, would be from isoleucine by analogy with senecic acid biosynthesis (see above); the C₅ unit which these atoms constitute is a common feature of the necic acids. Accordingly satisfactory incorporations of L-[U-¹⁴C]isoleucine and its precursor, L-[U-¹⁴C]threonine [as (50)], into (49) were observed and the activity was shown to be confined to the necic acid moiety.⁷¹ Moreover, the isoleucine was found to label C-1, -2, -3, -6, and -7 of monocrotaline

⁶⁷ N. M. Davies and D. H. G. Crout, *J.C.S. Perkin I*, 1974, 2079.

⁶⁸ I. Chibata, S. Yamada, H. Ito, and S. Ishikawa, *Appl. Microbiol.*, 1965, **13**, 680.

⁶⁹ M. Bodanszky and D. Perlman, *Nature*, 1968, **218**, 291; J. S. Davies, M. H. Foley, C. H. Hassall, and V. Arroyo, *J.C.S. Chem. Comm.*, 1973, 782; T. Yajima, M. A. Grigg, and E. Katz, *Arch. Biochem. Biophys.*, 1972, **151**, 565.

⁷⁰ E. K. Nowacki and R. U. Byerrum, *Life Sci.*, 1962, **1**, 157.

⁷¹ D. J. Robins, N. M. Bale, and D. H. G. Crout, *J.C.S. Perkin I*, 1974, 2082.

acid (48) most heavily and, as expected of incorporation of the threonine *via* isoleucine (Scheme 9),⁶⁶ C-1, -3, and -7 of (48) were the most heavily labelled by this precursor.⁷¹

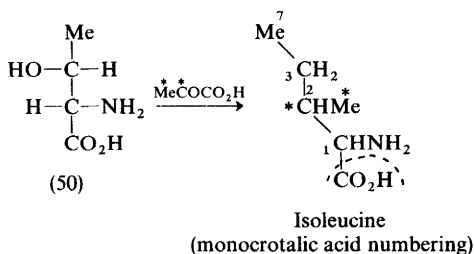

Scheme 9

Propionate, a plausible source for C-4, -5, and -8 of (48), has been shown to act as a precursor for the necic acid moiety of monocrotaline (49).⁷⁰ The observed labelling⁷¹ of these atoms in (48) by L-[U-¹⁴C]isoleucine and L-[U-¹⁴C]threonine is consistent with a precursor role for propionate since both of these amino-acids can give propionyl-CoA.⁷² Confirmation that propionate is the source of C-4, -5, and -8 of (48) is awaited.

In summary it is to be noted that the evidence available now on the biosynthesis of the necic acids points to branched-chain amino-acids as precursors. As discussed in part above, isoleucine has been shown to be a precursor for the necic acids of the senecic [as (47)]^{66,67,73} and monocrotalic (49) types,⁷¹ and of the angelic acid component of heliosupine.⁷⁴ Valine, on the other hand, is a specific precursor of the echimidinic acid (51) moiety in heliosupine.⁷⁵

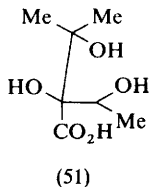

Nicotine.—Following on earlier work,^{13a} the metabolism of nicotine (52) in *Nicotiana glauca* has been studied⁷⁶ with particular emphasis on the mechanism of the conversion of nicotine into nornicotine (53). A mixture of (–)-[2'-³H]nicotine

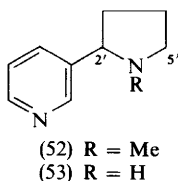

⁷² V. W. Rodwell, in 'Metabolic Pathways', Vol. III, 3rd edn., ed. D. M. Greenberg, Academic Press, New York and London, 1969, p. 201.

⁷³ D. H. G. Crout, M. H. Benn, H. Imaseki, and T. A. Geissman, *Phytochemistry*, 1966, **5**, 1.

⁷⁴ D. H. G. Crout, *J. Chem. Soc. (C)*, 1967, 1233.

⁷⁵ D. H. G. Crout, *J. Chem. Soc. (C)*, 1966, 1968.

⁷⁶ E. Leete and M. R. Chedekel, *Phytochemistry*, 1974, **13**, 1853.

[as (52)] and (\pm)-[2'-¹⁴C]nicotine was fed to *N. glauca* plants, and potential metabolites of nicotine besides nornicotine were added as carriers during harvesting. These compounds were myosmine (previously isolated from *N. tabacum* after feeding radioactive nornicotine),⁷⁷ cotinine (5'-oxonicotine, a major nicotine metabolite in animals),⁷⁸ 3-acetylpyridine (a microbial degradation product of nicotine),⁷⁹ and nicotinic acid (a metabolite of nicotine in *N. rustica*).⁸⁰ Negligible activity was found in anabasine (in agreement with earlier work),⁸¹ cotinine, 3-acetylpyridine, and nicotinic acid. Nornicotine (53) was found to be the major metabolite of nicotine.⁷⁶ The transformation did not result in change in the ³H/¹⁴C ratio of the administered nicotine, and so (+)- and (-)-nicotine must be demethylated at similar rates in *N. glauca*. This contrasts with the finding⁸² that, in *N. tabacum*, unnatural (+)-nicotine is demethylated more slowly than (-)-nicotine.

The nornicotine isolated in the experiments in *N. glauca* was almost completely racemic [which again contrasts with results for *N. tabacum*, where the nornicotine derived from (-)-nicotine was found to be partially racemized⁸³]. Only the (-)-isomer contained tritium (which was located at C-2').⁷⁶ Thus, formation of any (+)-nornicotine from (-)-nicotine in *N. glauca* involves loss of hydrogen from C-2' and any hypothesis⁷⁶ involving its retention is invalidated.

The myosmine (54) isolated in the above experiments⁷⁶ was appreciably radioactive, but as expected it was devoid of tritium. On the other hand the ¹⁴C label

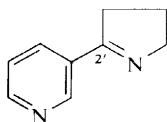

(54)

was specifically incorporated. Labelled myosmine was found not to be incorporated into nornicotine or nicotine (or anabasine), thus indicating that the formation of myosmine from nicotine, presumably *via* nornicotine, is irreversible. The myosmine isolated at the end of the experiment showed a decrease in specific activity, *i.e.* dilution by inactive material, from which it follows that myosmine is a normal constituent of *N. glauca*, in agreement with other work.⁸⁴ Finally, the isolation of radioactive nicotinic acid following the feeding of labelled myosmine indicates that it is a metabolite of myosmine, again in agreement with other work.⁷⁷

In conclusion, it is clear from the combined results that nicotine may be metabolized by the pathway nicotine \rightarrow (53) \rightarrow (54) \rightarrow nicotinic acid, but the mechanism for the first step of demethylation is still obscure.

⁷⁷ T. Kasaki and E. Tamaki, *Phytochemistry*, 1966, **5**, 293.

⁷⁸ Cf. H. McKennis, in 'Tobacco Alkaloids and Related Compounds', ed. U. S. von Euler, Pergamon, Oxford, 1965, p. 53.

⁷⁹ W. G. Frankenburg and A. A. Vaitekunas, *Arch. Biochem. Biophys.*, 1955, **58**, 509.

⁸⁰ G. D. Griffith, T. Griffith, and R. U. Byerrum, *J. Biol. Chem.*, 1960, **235**, 3536.

⁸¹ E. Leete, *Tetrahedron Letters*, 1968, 4433.

⁸² T. Kasaki and E. Tamaki, *Arch. Biochem. Biophys.*, 1961, **94**, 252.

⁸³ T. Kasaki and E. Tamaki, *Arch. Biochem. Biophys.*, 1961, **92**, 351.

⁸⁴ O. Fejér-Kossey, *Phytochemistry*, 1972, **11**, 415.

3 Isoquinoline Alkaloids

The number of alkaloids based on the 1-substituted tetrahydroisoquinoline skeleton is legion and the structural variation which this skeleton affords, particularly in the case of 1-benzylisoquinolines, is rich. The 1-substituted isoquinoline skeleton of each kind probably arises by the common step of condensing a β -arylethylamine with an appropriate carbonyl compound, for which the Pictet-Spengler reaction provides an analogy. In some cases the participation of a carbonyl compound is established but in others it is still speculative. Recently progress has been made in this area in studies on the biosynthesis of lophocerine, the *Papaver* alkaloids, and to some extent the cryptostyline alkaloids with their novel 1-phenylisoquinoline structures.

Cryptostyline.—The cryptostyline alkaloids, e.g. (–)-cryptostyline-I (55), are the first isoquinoline alkaloids to be isolated from nature with a phenyl group at C-1, which makes them a group of bases of some biosynthetic interest. The biosynthesis of the cryptostyline skeleton, apart from the phenyl substituent and C-1, is accounted for in terms of a pathway which passes from tyrosine and dopa through dopamine. This conclusion follows the finding that ^{14}C -labelled tyrosine, tyramine, dopa, and dopamine are incorporated into (–)-cryptostyline-I (55) in *Cryptostylis erythroglossa*.⁸⁵ Results from feeding the isomeric phenethylamines (56) and (57)

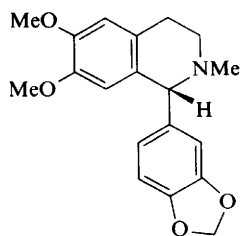

(55)

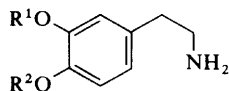
(56) $\text{R}^1 = \text{H}, \text{R}^2 = \text{Me}$ (57) $\text{R}^1 = \text{Me}, \text{R}^2 = \text{H}$

indicate that only the former, with hydroxy-group *para* to the position at which ring closure eventually occurs, is a precursor. 3,4-Dimethoxyphenethylamine was found to be specifically incorporated but at a lower level than dopamine⁸⁶ [it seems probable that this compound is demethylated to (56) before incorporation into the alkaloid]. In sum the pathway so far delineated is broadly similar to the one deduced in detail for the cactus alkaloids.⁸⁷

Both dopamine and vanillin (but not isovanillin) serve as precursors for the remaining $\text{C}_6\text{--C}_1$ residue in cryptostyline-I.⁸⁶ The incorporation of vanillin was at a low level, but this was attributed to poor absorption into the plant. Protocatechualdehyde, the known precursor for the $\text{C}_6\text{--C}_1$ unit found in the Amarylidiaceae alkaloids,⁸⁸ has not yet been tested as a precursor.

⁸⁵ S. Agurell, I. Granelli, K. Leander, B. Luning, and J. Rosenblom, *Acta Chem. Scand.*, 1974, **B28**, 239.

⁸⁶ S. Agurell, I. Granelli, K. Leander, and J. Rosenblom, *Acta Chem. Scand.*, 1974, **B28**, 1175.

⁸⁷ For reviews see: J. Lundström, *Acta Pharm. Suecica*, 1971, **8**, 275; R. B. Herbert in ref. 1, p. 16; ref. 3, p. 16.

⁸⁸ R. J. Suhadolnik, A. G. Fischer, and J. Zulalian, *Proc. Chem. Soc.*, 1963, 132; C. Fuganti and M. Mazza, *Chem. Comm.*, 1971, 1196; R. B. Herbert in ref. 3, p. 21.

The amine (58) was incorporated with low efficiency.⁸⁶ Failure of compounds of this type to act as precursors does not seem surprising since their formation *in vivo* implies a reduction following the condensing together of plausible precursors (amine plus carbonyl compound; see, for example, lophocerine below), and subsequent ring closure requires oxidation of this secondary amine. The immonium salt (59) is a highly efficient precursor for cryptostyline-I and a role for it as an intermediate in cryptostyline biosynthesis is thus suggested.

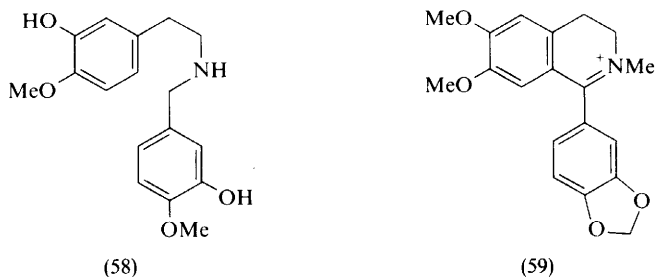

Cactus Alkaloids.—Lophocerine (63) is unusual among isoquinoline alkaloids in having an isobutyl group at C-1. This group together with C-1 forms a five-carbon unit which is specifically labelled by mevalonic acid and leucine.^{89,90} The observation⁸⁹ that the former is a more efficient precursor for lophocerine than the latter has been confirmed.⁹¹ One interpretation of these results is that leucine is incorporated into the alkaloid through conversion *in vivo* into mevalonic acid. This hypothesis was examined⁹¹ by feeding 3-methylbutanoic acid, which in the form of its coenzyme A ester is reported as an intermediate on the pathway from leucine to mevalonic acid.⁹² No activity was transferred to lophocerine from the [1-¹⁴C]-3-methylbutanoic acid administered, thus suggesting that incorporation of leucine is not *via* mevalonic acid and supporting an alternative interpretation of the results above, namely a dual origin for the C₅ unit of lophocerine.

The steps which lie between mevalonic acid and lophocerine have been explored by feeding [1-¹⁴C]-3-methylbut-3-enyl pyrophosphate (60), [1-¹⁴C]-3-methylbutan-1-ol (61), and [1-¹⁴C]-3-methylbutanal (62).⁹¹ All three labelled substrates were assimilated into lophocerine; the aldehyde was the least efficient precursor but nonetheless was shown to be specifically incorporated. The results support then the pathway from mevalonic acid to lophocerine (63) shown in Scheme 10.

The apparent use of an aldehyde function to form the junction of the C₅ unit with phenethylamine fragment in lophocerine biosynthesis makes an interesting contrast with the biosynthesis of the related alkaloids anhalamine (65) and anhalonidine (66), where the α -carbonyl acids, glyoxylic acid and pyruvic acid respectively, are very evidently intermediates.⁹³ The analogous keto-acid for lophocerine is (64), simply

⁸⁹ D. G. O'Donovan and H. Horan, *J. Chem. Soc. (C)*, 1968, 2791.

⁹⁰ H. R. Schütte and G. Seelig, *Annalen*, 1970, **730**, 186; R. B. Herbert, in ref. 1, p. 17.

⁹¹ D. G. O'Donovan and E. Barry, *J.C.S. Perkin I*, 1974, 2528.

⁹² K. Bloch, *J. Biol. Chem.*, 1944, **155**, 255; M. J. Coon, *ibid.*, 1950, **187**, 71; M. J. Coon and D. Robinson, *Ann. Rev. Biochem.*, 1958, **27**, 561.

⁹³ G. J. Kapadia, G. S. Rao, E. Leete, M. B. E. Fayed, Y. N. Vaishnav, and H. M. Fales, *J. Amer. Chem. Soc.*, 1970, **92**, 6943; J. Staunton in ref. 2, p. 10.

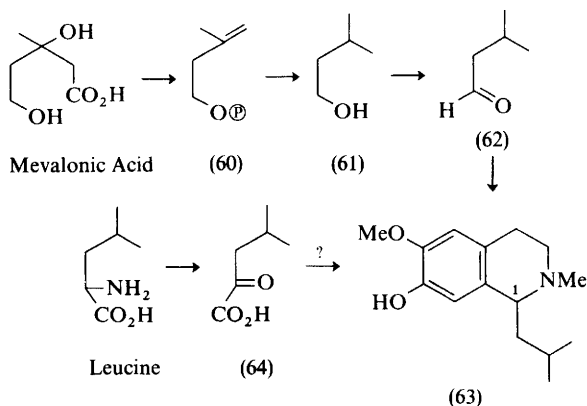

Scheme 10

formed from the precursor leucine by transamination. The possible intermediacy of this compound in lophocerine biosynthesis does not seem to have been examined yet.



Since α -amino-acids serve as starting materials for the synthesis of protein and the elaboration of many plant alkaloids, there must be a sharing of any amino-acid which is required for both of these activities. The extent to which this happens has been the subject of a new study⁹⁴ in one particular plant, *Lophophora williamsii*, which produces isoquinoline and β -phenethylamine alkaloids. These bases are derived from the α -amino-acid tyrosine and the results from feeding L-[U-¹⁴C]tyrosine indicate that this amino-acid is incorporated into the alkaloids approximately three times more efficiently than into protein. Only the L-isomer was examined and one wonders what the results with D-tyrosine would be in the light of the known preference⁹⁵ for particular optical isomers of lysine in pipercolic acid and piperidine alkaloid biosynthesis.

As added inactive tyrosine and *p*-hydroxyphenylpyruvic acid caused a greater dilution of activity in the protein than in the alkaloid being synthesized from [U-¹⁴C]fructose a separation of these two activities in *L. williamsii* into compartments was suggested.⁹⁴

Papaver Alkaloids.—It is well established that the 1-benzylisoquinoline skeleton [as (70)] found in the alkaloids of *Papaver* species, amongst many others, arises from two molecules of tyrosine, with dopamine serving as an intermediate for one half of the skeleton (see Scheme 11).⁹⁶ In spite of the extensive and fruitful studies on

⁹⁴ H. Rosenberg and S. J. Stohs, *Phytochemistry*, 1974, **13**, 1861.

⁹⁵ T. J. Gilbertson, *Phytochemistry*, 1972, **11**, 1737; R. B. Herbert, in ref. 3, p. 25; E. Leistner, R. N. Gupta, and I. D. Spenser, *J. Amer. Chem. Soc.*, 1973, **95**, 4040; R. B. Herbert, in ref. 5, p. 7.

⁹⁶ H. R. Schütte, in ref. 6, p. 367; I. D. Spenser, in ref. 7, p. 309.

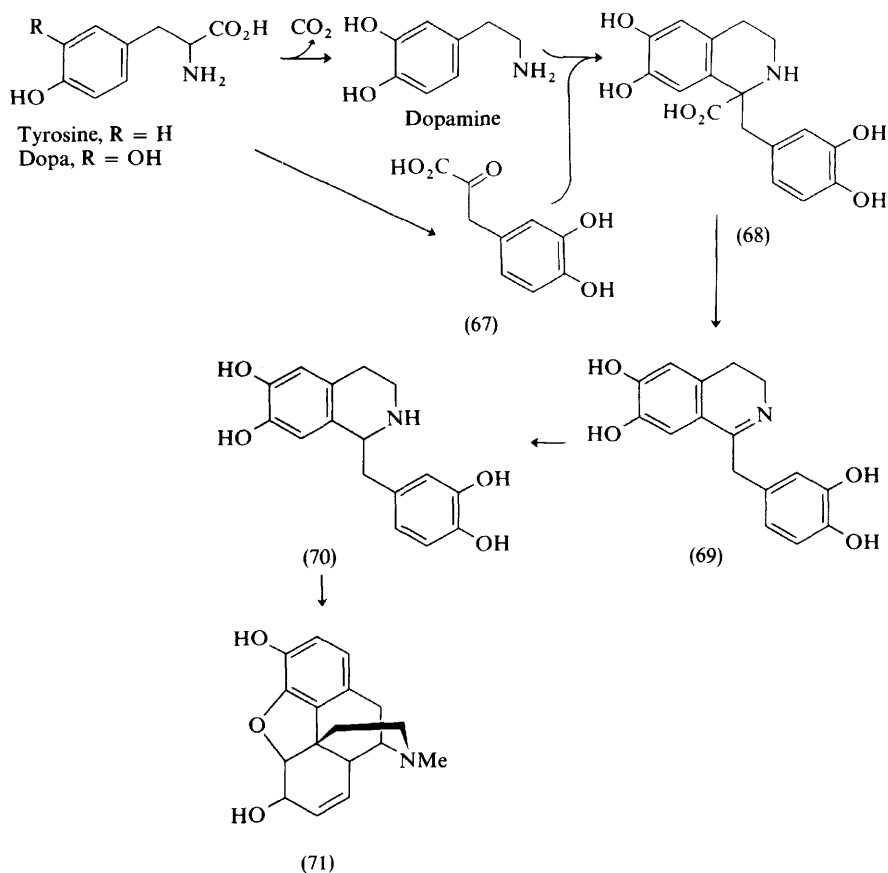

Scheme 11

benzylisoquinoline biosynthesis, however, research rather than speculation on the nature of the molecule which condenses with dopamine to give the benzylisoquinoline skeleton had remained neglected until recently, when evidence was provided for the pathway shown in Scheme 11.^{97,98}

The pathway illustrated represents the conclusions of studies using *Papaver orientale* seedlings and latex (which gave substantially better incorporations)⁹⁷ and *P. Somniferum* plants.⁹⁸ Not only was norlaudanosoline (70) labelled by [1-¹⁴C,2-³H]dopamine (without change in isotope ratio) but also the previously unknown amino-acid (68),⁹⁷ which was isolated when inactive material was used as carrier. [1-¹⁴C]Dopa gave radioactive (68) but did not label norlaudanosoline (70), which shows that C-1 of dopa is specifically the source of the carboxy-group of (68). On the other hand dopa with labels elsewhere afforded radioactive samples of (68) and (69).

⁹⁷ M. L. Wilson and C. J. Coscia, *J. Amer. Chem. Soc.*, 1975, **97**, 431.

⁹⁸ A. R. Battersby, R. C. F. Jones, and R. Kazlauskas, *Tetrahedron Letters*, 1975, 1873.

Further evidence implicating (68) as an intermediate in isoquinoline biosynthesis comes from the efficient incorporation of labelled (68) into (70)⁹⁷ and with the specific incorporation, albeit with low efficiency, of labelled (68) into morphine (71).⁹⁸ The amino-acid (72) was a very poor precursor for morphine, which indicates that both aromatic building blocks must be dihydroxylated before they are joined together. Simple chemical decarboxylation of (68) affords (69), which was found to act as a precursor for morphine [the triphenol (73) was incorporated too but at a lower level].⁹⁸ These observations taken with the labelling of (69) by dopa in *P. orientale*⁹⁷ suggest that the imine (69) may also be an intermediate in isoquinoline biosynthesis.

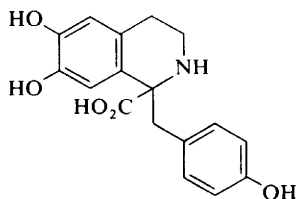

(72)

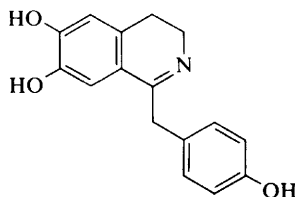

(73)

If the amino-acid (68) is a biosynthetic intermediate it clearly arises *in vivo* from dopamine and 3,4-dihydroxyphenylpyruvic acid (67). The latter compound is derived from dopa by transamination and the conversion of dopa into (68) thus involves competing processes of decarboxylation and transamination. In *P. orientale* the former process was apparently favoured seven-fold over transamination⁹⁷ whereas in *P. somniferum* [2-¹⁴C]dopa was only incorporated into morphine *via* dopamine.⁹⁸ An explanation of the latter result is that the dopa fed fails to penetrate to the site of the appropriate transaminase in this plant.

The biosynthetic pathway which is indicated by the above results is illustrated in Scheme 11; norlaudanosine (70) had previously been shown to be a morphine (71) precursor.^{96,99} The implication of a keto-acid rather than an aldehyde in benzylisoquinoline formation accords with observations on the biosynthesis of simpler isoquinolines⁹³ and stands in contrast with the utilization of an aldehyde, secologanin, in a similar reaction in the biosynthesis of terpenoid indole alkaloids.¹⁰⁰

Aporphine Alkaloids.—The biosynthesis of the proaporphine and aporphine alkaloids of *Croton sparsiflorus* has been investigated and found to be unexceptional.¹⁰¹ Thus [2-¹⁴C]tyrosine was found to be a precursor for crotsparine (74), crotsparinine (75), and sparsiflorine (76). Moreover, labelled (±)-coclaurine (77), but not (±)-isococlaurine (78), was found to give radioactive alkaloids. Coclaurine was also shown to be present in *C. sparsiflorus* by means of a trapping experiment using [2-¹⁴C]tyrosine and inactive coclaurine: radioactive coclaurine was isolated at the end of the experiment.

⁹⁹ A. R. Battersby, R. Binks, R. J. Francis, D. J. McCaldin, and H. Ramuz, *J. Chem. Soc.*, 1964, 3600.

¹⁰⁰ A. R. Battersby, in ref. 1, p. 31.

¹⁰¹ D. S. Bhakuni, S. Satish, H. Uprety, and R. S. Kapil, *Phytochemistry*, 1974, **13**, 2767.

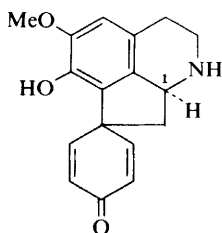

(74)

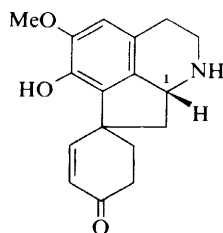

(75)

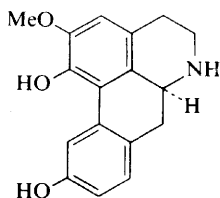

(76)

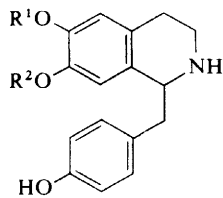
(77) $R^1 = \text{Me}, R^2 = \text{H}$
(78) $R^1 = \text{H}, R^2 = \text{Me}$

These results provide strong evidence that coclaurine is a normal intermediate in the biosynthesis of the alkaloids in this plant, and they are in accord with theory¹⁰² and the substantial body of results obtained for alkaloids of this type:^{96,103} in all cases the benzyloquinoline precursor on which cyclization occurs has hydroxy-groups *ortho* or *para* to the sites involved in ring closure. Further detail is that crotsparinine (74), crotsparinine (75), and sparsiflorine (76) are converted *in vivo* into their respective *N*-methyl derivatives.¹⁰¹

The possible interrelationships of (74), (75), and (76) have not been investigated, but it is to be noted that (74) and (76) are of opposite configuration to (75) at C-1, suggesting that (74) and (76) biosynthesis diverges from that of (75) by way of the appropriate enantiomer of coclaurine (77).

In practice^{96,103} a particular aporphine alkaloid may be derived *a priori* from a number of diphenolic benzyloquinoline precursors either by direct coupling or through the genesis of a dienone intermediate as seen above. Thus in the study¹⁰⁴ of the superficially simple alkaloid boldine (79), a number of benzyloquinoline precursors had to be tested. Experiments were carried out with labelled samples of (\pm)-norprotosinomenine (83), (\pm)-nororientaline (84), (\pm)-4'-*o*-methyl-norlaudanosoline (85), (\pm)-norreticuline (86), (\pm)-reticuline [as (82)], and the completely methylated base (\pm)-laudanosine (87) in *Litsea glutinosa*.¹⁰⁴ Only (85), norreticuline (86), and reticuline [as (82)] were found to be effective precursors (degradation also showed that the latter two compounds were specifically incorporated) and it was further established that (+)-reticuline (82) (with the same stereochemistry as boldine) but not its enantiomer is implicated in the biosynthesis of boldine (79).

¹⁰² D. H. R. Barton and T. Cohen, Festschrift A. Stoll, Birkhäuser, Basel, 1957, p. 117; H. Erdtman and C. A. Wachtmeister, *ibid.*, p. 144.

¹⁰³ R. B. Herbert, in ref. 1, p. 19; ref. 3, p. 19; ref. 4, p. 17; ref. 5, p. 15; J. Staunton, in ref. 2, p. 12.

¹⁰⁴ S. Tewari, D. S. Bhakuni, and R. S. Kapil, *J.C.S. Chem. Comm.*, 1974, 940.

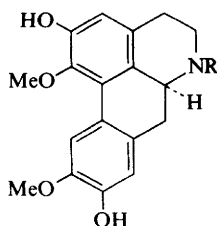

(79) R = Me

(80) R = H

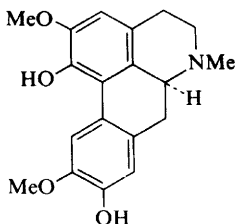

(81)

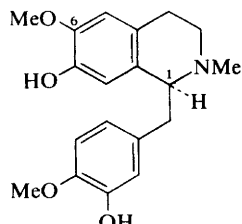

(82)

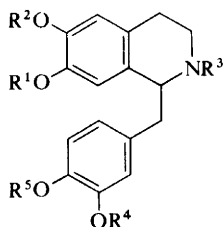
(83) R¹ = R⁵ = Me, R² = R³ = R⁴ = H(84) R¹ = R³ = R⁵ = H, R² = R⁴ = Me(85) R¹ = R² = R³ = R⁴ = H, R⁵ = Me(86) R¹ = R³ = R⁴ = H, R² = R⁵ = Me(87) R¹ = R² = R³ = R⁴ = R⁵ = Me

The methylation pattern of boldine (79) might have been taken to indicate a biosynthetic pathway similar to that of the aporphine alkaloids of *Dicentra eximia*,¹⁰⁵ but the above results clearly refute this idea. The change in the methylation pattern from reticuline (82) to boldine (79) is not apparently due to methyl migration for (±)-[6-¹⁴OCH₃, 1-³H]reticuline [as (82)] was incorporated with loss of 64% of the ¹⁴C label;¹⁰⁴ similar results have been obtained in the related case of crotonosine biosynthesis.¹⁰⁶

Both (+)-isoboldine (81) and (+)-norboldine (80) were specifically incorporated into boldine (79).¹⁰⁴ Isoboldine (81) and reticuline [as (82)] had previously been isolated from *L. glutinosa*¹⁰⁷ and the presence of the latter in this plant was confirmed in a trapping experiment with [*U*-¹⁴C]tyrosine.¹⁰⁴ The presence of (85) in the plant was established in the same way. A convincing picture is thus built up for the biosynthesis of boldine: (85) → (86) → (82) → (81) → boldine (79). It is interesting to note that reticuline (82), used for the biosynthesis of so many benzylisoquinoline alkaloids,^{96,103} is again a key intermediate.

The isolation of the aporphine alkaloid (88) from the same plant as (+)-thalpenine (90) has led to the suggestion that the methyleneoxy bridge found in the latter arises

¹⁰⁵ A. R. Battersby, J. L. McHugh, J. Staunton, and M. Todd, *Chem. Comm.*, 1971, 985; J. Staunton, in ref. 2, p. 12.

¹⁰⁶ D. H. R. Barton, D. S. Bhakuni, G. M. Chapman, G. W. Kirby, L. J. Haynes, and K. L. Stuart, *J. Chem. Soc. (C)*, 1967, 1295.

¹⁰⁷ N. K. Hart, S. R. Johns, J. A. Lamberton, J. W. Loder, A. Moorhouse, A. A. Sioumis, and T. K. Smith, *Austral. J. Chem.* 1969, **22**, 2259.

by oxidation of one of the methyl groups of (88) with (89) as a plausible intermediate.¹⁰⁸ It was further suggested that a similar mechanism may accommodate the formation of this bridge in bisbenzylisoquinoline alkaloids.

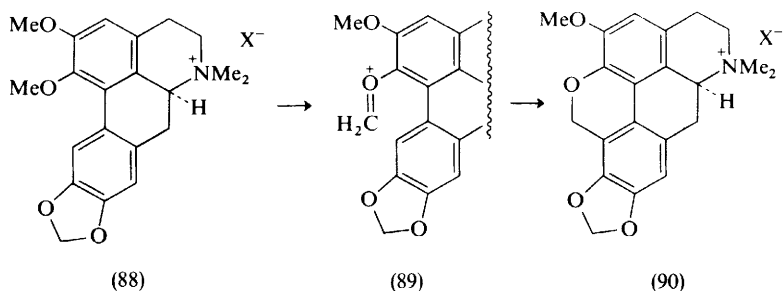

Protopine.—It is known that protopine (94) is elaborated *in vivo* along a route which involves (+)-reticuline (82)¹⁰⁹ and (-)-scoulerine (91) and, probably, stylophine (92).¹¹⁰ The quaternary salt (93) is also to be included in the pathway, a conclusion which follows from the incorporation into protopine (94), in *Corydalis incisa*, of [*N*-Me-¹⁴C]tetrahydrocoptisine methochloride [as (93)] without loss of the *N*-methyl group.¹¹¹ [Label from this salt was not incorporated into corynoline (95).]

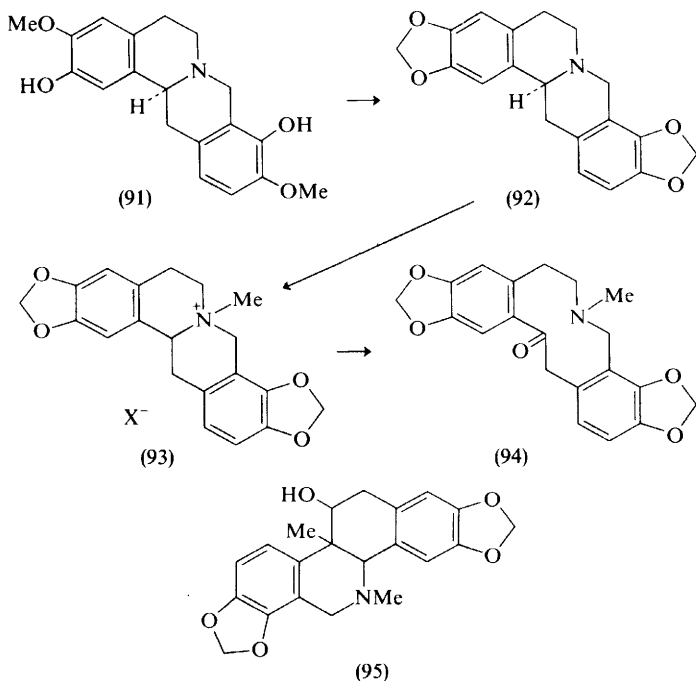

¹⁰⁸ M. Shamma and J. L. Moniot, *Heterocycles*, 1974, **2**, 427.

¹⁰⁹ D. H. R. Barton, R. H. Hesse, and G. W. Kirby, *J. Chem. Soc.*, 1965, 6379.

¹¹⁰ A. R. Battersby, R. J. Francis, M. Hirst, R. Southgate, and J. Staunton, *Chem. Comm.*, 1967, 602.

¹¹¹ C. Tani and K. Tagahara, *Chem. and Pharm. Bull. (Japan)*, 1974, **22**, 2457.

Corydaline and Ochotensimine.—It has been widely presumed that the alkaloids corydaline (98) and ochotensimine (99) are further structural variants of the benzylisoquinoline skeleton (*cf.* refs. 112 and 113). A firm indication that this view is correct for corydaline came from the incorporation of labelled reticuline [as (82)] into the alkaloid.¹¹⁴ Further evidence for such a route to corydaline and the first evidence on the biosynthesis of ochotensimine (99) have been obtained from feeding experiments with labelled tyrosine and methionine in *Corydalis* species.¹¹⁵

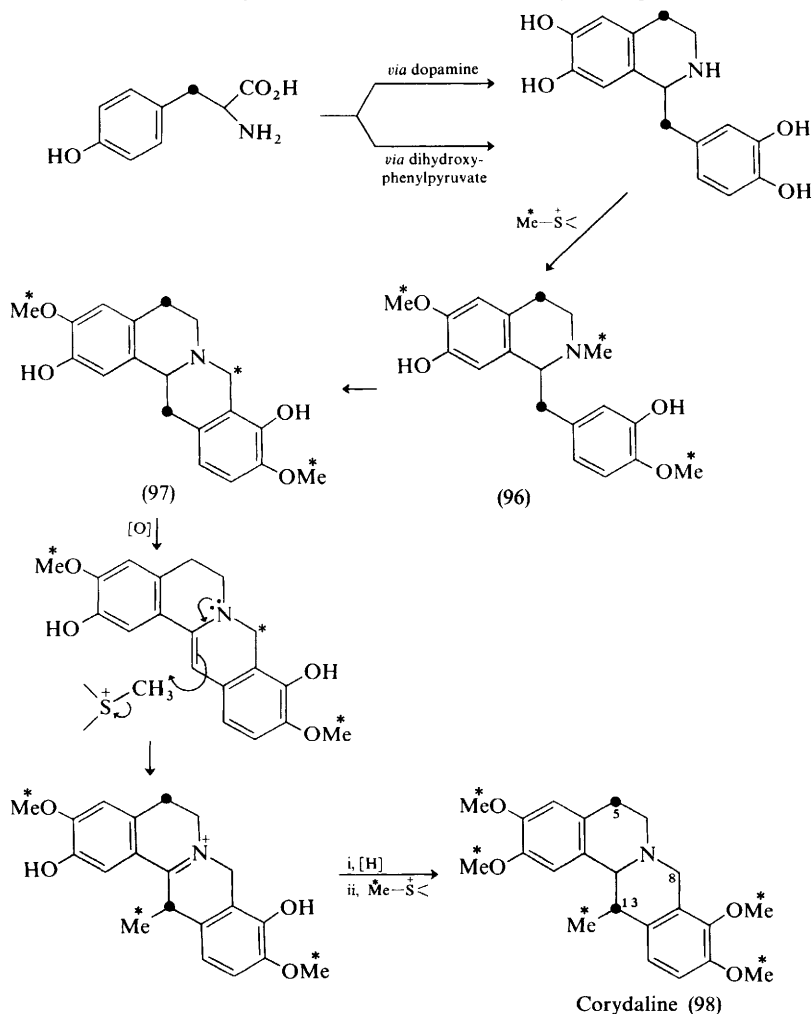

Scheme 12

¹¹² M. Shamma and C. D. Jones, *J. Amer. Chem. Soc.*, 1970, **92**, 4943; M. Shamma and J. F. Nugent, *Tetrahedron*, 1973, **29**, 1265.

¹¹³ R. Robinson, 'The Structural Relations of Natural Products', Oxford University Press, 1955, p. 87.

¹¹⁴ G. Blaschke, *Arch. Pharm.*, 1968, **301**, 439; *ibid.*, 1970, **303**, 358; R. B. Herbert, in ref. 1, p. 21.

¹¹⁵ H. L. Holland, M. Castillo, D. B. MacLean, and I. D. Spenser, *Canad. J. Chem.*, 1974, **52**, 2818.

Label from [$Me-^{14}C$]methionine was incorporated into corydaline (98), 19% of the total activity being found at the C-methyl group of the alkaloid. This is consistent with a biosynthetic pathway which follows that established⁹⁶ for protoberberine alkaloids [as (97)], with introduction of an 'extra' C-methyl group at some point. The pathway is further corroborated by the finding¹¹⁵ that a further 18% of the total radioactivity was located at C-8, the ostensible 'berberine-bridge' carbon.⁹⁶ (The remainder of the radioactivity was present in the four methoxy-groups.)

Genesis of corydaline (98) along the protoberberine route requires labelling of C-5 and C-13 by [$3-^{14}C$]tyrosine⁹⁶ and, in accord with this, one half of the tyrosine label incorporated into (98) was found to be at C-13.¹¹⁵ Clear support is thus provided by the above results for a pathway (Scheme 12) similar to that for the protoberberine alkaloids. (The illustrated pathway includes a plausible mechanism for the C-methylation reaction but neither the mechanism nor the point after reticuline at which methylation occurs has yet been established.)

Chemical analogy exists^{112,116} for the biogenesis of ochotensimine (99) from the corydaline skeleton. The validity of such a pathway *in vivo* was established by examining the fates of methionine and tyrosine labels in ochotensimine: radioactivity from [$Me-^{14}C$]methionine was found as a skeletal label at C-9 and on the exocyclic methylene group, whereas [$3-^{14}C$]tyrosine gave ochotensimine with half its label at C-14 (the other half is presumed to be at C-5). These results are completely in accord with those expected of the hypothesis (Scheme 13) and strongly support genesis of ochotensimine (99) by rearrangement of a C-13-methylated protoberberine of the corydaline type.

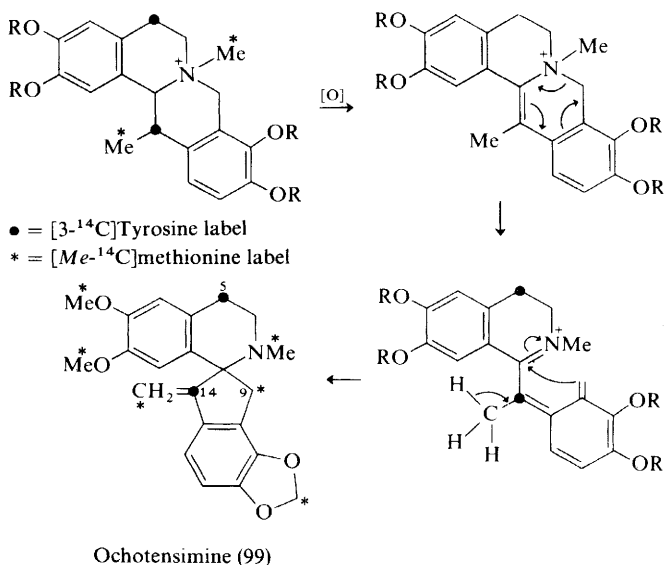

Scheme 13

¹¹⁶ B. Nalliah, R. H. F. Manske, R. Rodrigo, and D. B. MacLean, *Tetrahedron Letters*, 1973, 2795.

[Me- ^{14}C , ^3H]Methionine gives corydaline (98) with retention of 92% of the tritium in the five methyl groups and 'berberine-bridge' carbon. Formation of the berberine bridge is by oxidation of an *N*-methyl group in an isoquinoline precursor [as (96)]⁹⁶ and involves, overall, obligatory loss of one hydrogen atom; incorporation of the other methyl groups should not result in hydrogen loss, so a maximum of 17 of the 18 hydrogen atoms (94%) arising from methionine should be retained. This is in fact close to the observed tritium retention value. Oxidation of the isoquinoline *N*-methyl group, however, would be expected¹¹⁷ to result in tritium retention by a primary isotope effect, so a value close to 100% for tritium retention might have been predicted. No results for ochotensimine (99) with [Me- ^{14}C , ^3H]methionine are available but it can be predicted that formation of this alkaloid, although it involves loss of hydrogen from a *C*-methyl, an *O*-methyl, and an *N*-methyl group, should again result in tritium retention approaching 100%.

Erythrina Alkaloids.—The *Erythrina* alkaloids, e.g. erythraline (103), have been shown to be artful variations on the benzyloisoquinoline theme. They arise from the benzyloisoquinoline (*S*)-*N*-norprotosinomenine (100) *via* the dibenzazonine (101) and erysodienone (102).¹¹⁸

Recent results¹¹⁹ have shown that only (–)-erysodienone, which has the (5*S*)-chirality of the natural alkaloids, is a precursor for erythraline (103) and α - and β -erythroidine (106). The conversion of (*S*)-*N*-norprotosinomenine (100) into (5*S*)-erysodienone (102), it is apparent, involves, formally at least, an inversion of chirality. However, the chirality of (100) may well be lost *in vivo* for it was found that the biosynthetic intermediate (101) prepared by chemical reduction from chiral erysodienone underwent very rapid racemization at room temperature.

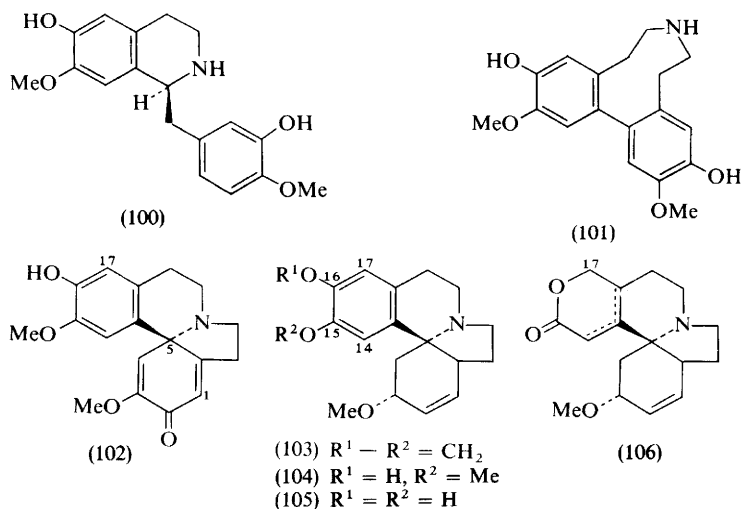

¹¹⁷ J. W. Cornforth, *Tetrahedron*, 1974, **30**, 1515 and refs. cited.

¹¹⁸ D. H. R. Barton, R. B. Boar, and D. A. Widdowson, *J. Chem. Soc. (C)*, 1970, 1213; R. B. Herbert, in ref. 1, p. 22; D. H. R. Barton, C. J. Potter, and D. A. Widdowson, *J.C.S. Perkin I*, 1974, 346; R. B. Herbert, in ref. 5, p. 24; D. H. R. Barton, R. James, G. W. Kirby, D. W. Turner, and D. A. Widdowson, *J. Chem. Soc. (C)*, 1968, 1529.

¹¹⁹ D. H. R. Barton, R. D. Bracho, C. J. Potter, and D. A. Widdowson, *J.C.S. Perkin I*, 1974, 2278.

Further experiments have established the aromatic *Erythrina* alkaloids as precursors for the lactonic bases (106). [$17\text{-}^3\text{H}$]Eryosidine [as (104)], [$14,17\text{-}^3\text{H}_2$]erysopine [as (105)], and (\pm) -[$1,17\text{-}^3\text{H}_2$]erysodienone [as (102)] were incorporated satisfactorily into α - and β -erythroidine (106); degradation of the material obtained after feeding [$17\text{-}^3\text{H}$]erysodienone established that the label was confined to C-17. This is the expected labelling site and the absence of scrambling is established.¹¹⁹

The biosynthesis of betalains provides a rare example of the cleavage of an aromatic ring in higher plants.¹²⁰ The conversion of alkaloids of the type (103) into (106) provides another; these results do not allow definition of the manner in which ring cleavage occurs since both intra-diol (C-15—C-16) and extra-diol (C-16—C-17) cleavage may lead to loss of C-16 and retention of tritium at C-17 as observed.

Hasubanonine and Protostephanine.—Among the alkaloids produced by *Stephania japonica* Miers are the biosynthetically intriguing bases hasubanonine (107) and protostephanine (108). Attempts to understand how these bases are formed *in vivo* have long been frustrated, although some progress has now been made.¹²¹ Intuitively one might feel that these alkaloids are based on the benzyloquinoline skeleton, but putative precursors with this skeleton (109)—(113), and the *O*-methyl and *N*-methyl derivatives of (109) and (110), together with the bisphenethylamines (114)

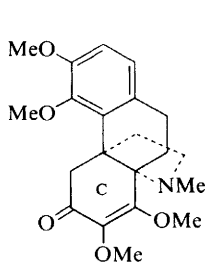

(107)

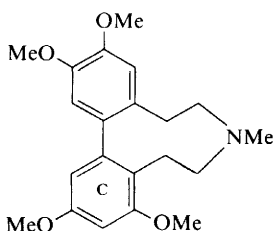

(108)

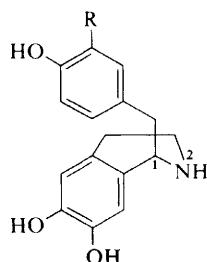
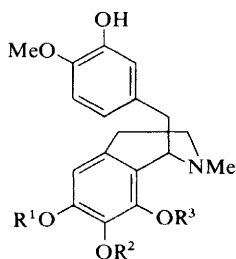
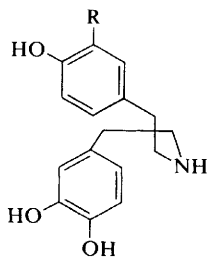
(109) R = H
(110) R = OH(111) R¹ = H, R² = R³ = Me(112) R² = H, R¹ = R³ = Me(113) R³ = H, R¹ = R² = Me

(114) R = OH

(115) R = H

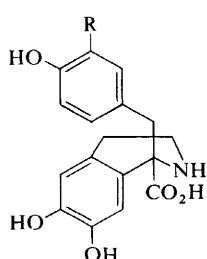

(116) R = OH

(117) R = H

¹²⁰ N. Fischer and A. S. Dreiding, *Helv. Chim. Acta*, 1972, **55**, 649; R. B. Herbert, in ref. 3, p. 8; G. Impellizzeri and M. Piattelli, *Phytochemistry*, 1972, **11**, 2499; R. B. Herbert, in ref. 4, p. 38.

¹²¹ A. R. Battersby, R. C. F. Jones, R. Kazlauskas, C. Poupat, C. W. Thornber, S. Ruchirawat, and J. Staunton, *J.C.S. Chem. Comm.*, 1974, 773.

and (115), were incorporated to an insignificant extent. Similar results were obtained with (116) and (117) and the 1,2-dehydro-derivatives of (109) and (110).

On the other hand, 2-¹⁴C-labelled tyrosine, dopa, tyramine, and dopamine were incorporated into both alkaloids and without randomization of label. The results show (a) that both alkaloids are constructed from two C₆-C₂ units, for which tyrosine is the source, and (b) that only one unit, *i.e.* the one which generates ring C with its attached ethanamine residue, is labelled by [2-¹⁴C]tyramine, [2-¹⁴C]dopamine, and [2-¹⁴C]dopa. This latter unit is manifestly a phenethylamine and the extent to which it is hydroxylated and methylated before combination with the other C₆-C₂ unit is next examined by feeding the phenethylamines (118)—(121) to *S. japonica*. The bases (118) and (119), but not (120) and (121), acted as precursors for hasubanonine (107) and protostephanine (108), from which it is clear that the phenethylamine involved in coupling with the other C₆-C₂ unit is a trioxxygenated, but monomethylated, derivative, *i.e.* (119). Combination of these two units gives sets of possible isoquinoline and bisphenethylamine precursors whose roles in hasubanonine and protostephanine biosynthesis have yet to be explored.

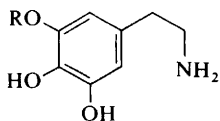

(118) R = H
(119) R = Me

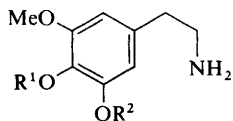

(120) R¹ = H, R² = Me
(121) R¹ = Me, R² = H

Cephalotaxine.—Cephalotaxine (122) is an abundant alkaloid of *Cephalotaxus* species. The natural co-occurrence of cephalotaxine and alkaloids of the homoerythrina type, *e.g.* 3-epischelhammericine (123), suggested that these two alkaloid

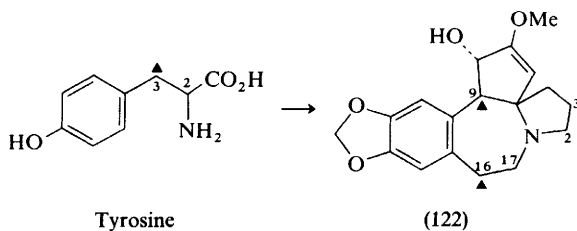

Scheme 14

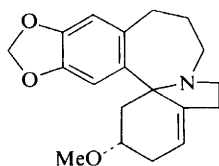

(123)

types might have a common progenitor in a phenethylisoquinoline [as (124)] which in turn would arise from phenylalanine and/or tyrosine.¹²²

Tyrosine was indeed found¹²² to be a precursor for cephalotaxine (122) but the labelling pattern precluded a phenethylisoquinoline intermediate. Thus [3-¹⁴C]tyrosine gave cephalotaxine with 68% of the activity at C-16 and 32% at C-9 (Scheme 14), whereas [2-¹⁴C]tyrosine labelled C-17 to the extent of 37% with no label at C-2 or C-3. It is to be noted that both samples of tyrosine were incorporated to similar extents and yet the expected correlation of activity between C-16 and C-17 is poor. This was attributed to some scatter of the label from C-2 of tyrosine. [1-¹⁴C]Tyrosine was only incorporated at a very low level and the activity appeared to be scattered. The results clearly implicate two molecules of tyrosine with loss of the carboxy-functions in a novel pathway to cephalotaxine. A scheme which is consistent with these results has been tentatively advanced (Scheme 15). This hypothesis is capable of further testing, which is in progress.

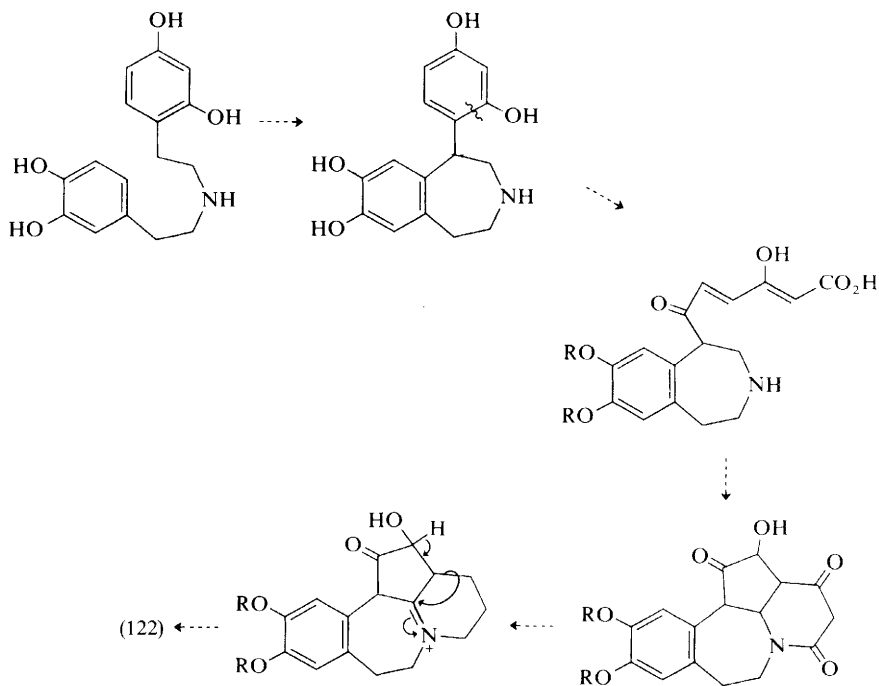

Scheme 15

Colchicine.—¹³C Labels have been used with great success in the study of the biosynthesis of microbial metabolites.¹²³ Application to plant alkaloid biosynthesis is limited in general by low incorporations of precursor and dilution of label by

¹²² R. J. Parry and J. M. Schwab, *J. Amer. Chem. Soc.*, 1975, **97**, 2555.

¹²³ M. Tanabe, in ref. 8, Vol. 3, p. 247, Vol. 2, p. 241; J. B. Grutzner, *Lloydia*, 1972, **35**, 375; H. G. Floss, *ibid.*, p. 399.

endogenous unlabelled material, but where these problems are not serious ^{13}C -labelled compounds may be used with success and the first two such studies have been reported recently, one on colchicine,¹²⁴ the other on camptothecin (see below).

Definitive evidence arising from ^{14}C - and ^3H -labelling studies points to the intermediacy of (*S*)-autumnaline (124) in the biosynthesis of colchicine (125).¹²⁵ The incorporation of (*RS*)-[1- ^{13}C]autumnaline [as (124)] into colchicine (125), with enhancement of the n.m.r. signal for C-7 only, affirms this conclusion.¹²⁴

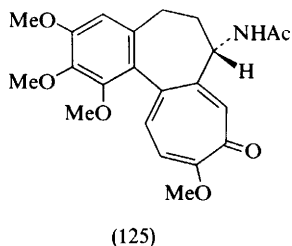
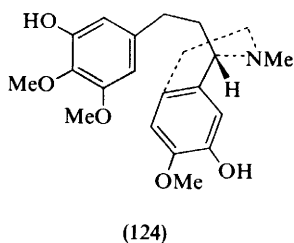

4 Alkaloids Derived from Tryptophan

Echinulin.—Most convincing evidence has been obtained that (126) is an intermediate in the biosynthesis of echinulin (127) in *Aspergillus amstelodami*.^{126,127} Possible mechanisms for introduction of the isoprene units on to the benzene ring of echinulin (127) and neoechinulin (128) are circumscribed by the results of feeding

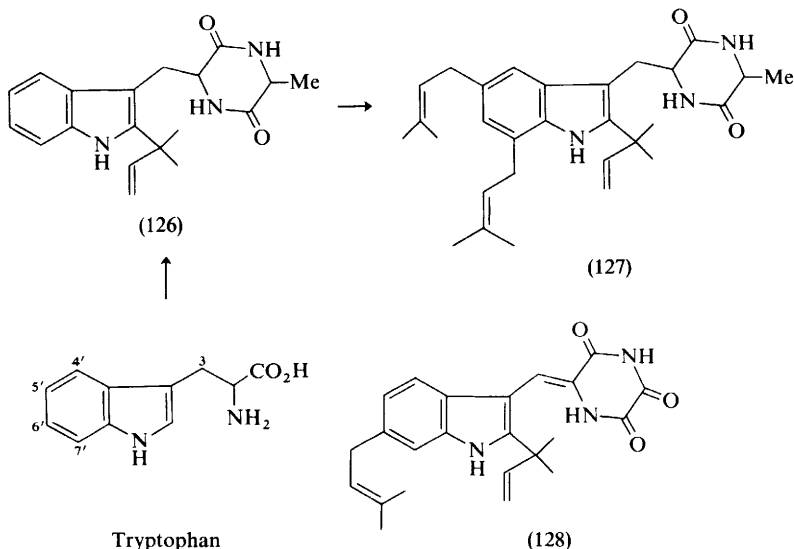

¹²⁴ A. R. Battersby, P. W. Sheldrake, and J. A. Milner, *Tetrahedron Letters*, 1974, 3315.

¹²⁵ A. R. Battersby, R. B. Herbert, E. McDonald, R. Ramage, and J. H. Clements, *J.C.S. Perkin I*, 1972, 1741; R. B. Herbert, in ref. 4, p. 19; A. C. Barker, A. R. Battersby, E. McDonald, R. Ramage, and J. H. Clements, *Chem. Comm.*, 1967, 390.

¹²⁶ C. M. Allen, jun., *Biochemistry*, 1972, **11**, 2154; *J. Amer. Chem. Soc.*, 1973, **95**, 2386.

¹²⁷ R. B. Herbert, in ref. 4, p. 29.

experiments with tryptophan samples tritiated in the benzene ring.¹²⁸ [5',7'-³H₂,3-¹⁴C]Tryptophan was incorporated into (127) and (128) with, respectively, 2% and 103% retention of tritium, whilst [4',6'-³H₂,3-¹⁴C]tryptophan was incorporated with, respectively, 102% and 52% tritium retention. These nicely complementary sets of results demonstrate that introduction of the isoprene units occurs with loss of hydrogen from the positions to which the isoprene units become attached but without disturbance of the hydrogen atoms on adjacent carbons. This incidentally excludes hydroxy-derivatives as intermediates.

Sporidesmin.—As part of the general interest currently being shown in the steric course of biosynthetic transformations,¹²⁹ the stereochemistry associated with entry of the hydroxy-group at C-3 of sporidesmin (129) has been investigated.¹³⁰ Samples

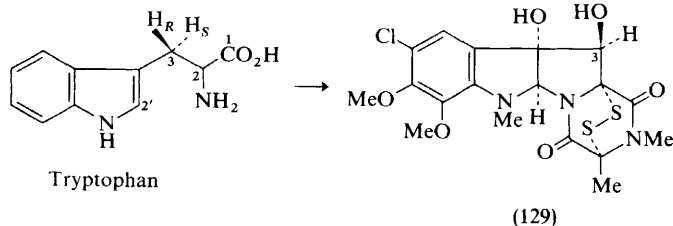

of (3*R*)- and (3*S*)-[3-³H]-DL-tryptophan were synthesized, and fed in admixture with tryptophan labelled with ¹⁴C in the side chain (C-1 or C-3) or the nucleus (C-2'). The level of tritium retention and loss was essentially independent of the position of the ¹⁴C-label. Consequently an intact incorporation of tryptophan is established and this is supported by the incorporation of DL-[2'-³H,3-¹⁴C]tryptophan without change in isotope ratio. This conclusion is in agreement with the results of an earlier study¹³¹ where evidence was obtained for the incorporation of tryptophan, alanine, and methionine.

The results with the tritiated tryptophan samples¹³⁰ further indicate that hydroxylation at the carbon which corresponds to C-3 of tryptophan occurs with loss of the *pro-R* hydrogen, *i.e.* hydroxylation with retention of configuration. This result was probably to be expected for it is a well-founded rule that biological hydroxylation occurs with retention of configuration, and this then is an additional example from the field of secondary metabolites.

Cyclopiazonic Acid.— α -Cyclopiazonic acid (132) is formed *in vivo* from tryptophan¹³² *via* (130)¹³³ and β -cyclopiazonic acid (131).¹³⁴ The stereochemistry of the final oxidative cyclization reaction has been explored using (3*RS*)-, (3*R*)-, and (3*S*)-[3-³H]tryptophan¹³⁵ (see above for application in a study of sporidesmin hydroxylation). Half the tritium was retained with the (3*RS*) sample, demonstrating that

¹²⁸ G. Casnati, G. P. Gardini, G. Palla, and C. Fuganti, *J.C.S. Perkin I*, 1974, 2397.

¹²⁹ Cf. A. R. Battersby and J. Staunton, *Tetrahedron*, 1974, **30**, 1707.

¹³⁰ G. W. Kirby and M. J. Varley, *J.C.S. Chem. Comm.*, 1974, 833.

¹³¹ N. R. Towers and D. E. Wright, *New Zealand J. Agric. Res.*, 1969, **12**, 275.

¹³² C. W. Holzapel and D. C. Wilkins, *Phytochemistry*, 1971, **10**, 351.

¹³³ R. M. McGrath, P. S. Steyn, and N. P. Ferreira, *J.C.S. Chem. Comm.*, 1973; 812; R. B. Herbert, *in ref.* 5, p. 26.

¹³⁴ J. C. Schabort, D. C. Wilkins, C. W. Holzapel, D. J. J. Potgieter, and A. W. Neitz, *Biochim. Biophys. Acta*, 1971, **250**, 311; J. C. Schabort and D. J. J. Potgieter, *ibid.*, p. 329.

¹³⁵ P. S. Steyn, R. Vlegaar, N. P. Ferreira, G. W. Kirby, and M. J. Varley, *J.C.S. Chem. Comm.*, 1975, 465.

the reaction involving C-3 (of tryptophan) was stereospecific. Complementary results were obtained with the (3*R*) and (3*S*) samples which establish that it is the 3-*pro-S* hydrogen of tryptophan which is lost on formation of α -cyclopiazonic acid (132) [β -Cyclopiazonic acid (131) isolated in these experiments showed high retention of tritium, thus affirming the integrity of the methylene group during the early stages of biosynthesis].

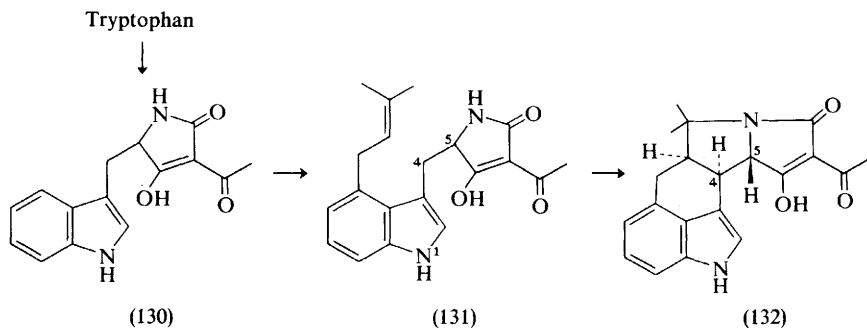

β -Cyclopiazonic acid (131) formed biosynthetically from [2 - ^3H]tryptophan was found to be converted into (132) *in vivo* without loss of tritium.¹³⁶ This is consistent with cyclization to (132) *via* a 1,4- but not a 4,5-dehydro-derivative of (131), and it follows then from the other results¹³⁵ and the stereochemistry of (132) that C—C bond formation at C-4 takes place from the opposite side of the molecule to proton removal.

Ergot.—It is now clear that the peptidic moiety of ergot alkaloids like ergotamine (133) and ergocryptine (134) is derived by combination of three appropriate α -amino-acids,^{137–140} but agreement is lacking on the sequence of reactions which leads from the amino-acids and lysergic acid to the alkaloids. On the one hand L-phenylalanyl-L-proline lactam (137) and L-leucyl-L-proline lactam (136) have been found to act as precursors for, respectively, ergotamine (133)¹⁴¹ and ergocryptine (134); in the biosynthesis of ergocryptine it appears that the lactam (136) subsequently undergoes coupling with (138), or its hydroxy-derivative, since lysergylvaline (138) was also found to be a precursor for this alkaloid¹⁴² (but see below). On the other hand, D-lysergyl-L-alanine was found not to be an intact precursor for ergotamine (133)¹⁴⁰ and similar results were obtained for the incorporation of D-lysergyl-L-valine into ergocornine (135) and ergocryptine (134).¹³⁹ Further

¹³⁶ C. W. Holzappel, unpublished work quoted in ref. 135.

¹³⁷ L. C. Vining and W. A. Taber, *Canad. J. Microbiol.*, 1963, **9**, 291; D. Gröger and D. Erge, *Z. Naturforsch.*, 1970, **25b**, 196; W. Maier, D. Erge, and D. Gröger, *Biochem. Physiol. Pflanzen*, 1971, **162**, 559; R. A. Bassett, E. B. Chain, and K. Corbett, *Biochem. J.*, 1973, **134**, 1; U. Nelson and S. Agurell, *Acta Chem. Scand.*, 1969, **23**, 3393; A. Minghetti and F. Arcamone, *Experientia*, 1969, **25**, 926; J. Majer, J. Kybal, and I. Komerova, *Folia Microbiol. (Prague)*, 1967, **12**, 489.

¹³⁸ R. B. Herbert, in ref. 1, p. 27; ref. 3, p. 6; ref. 4, p. 32; ref. 5, p. 27; J. Staunton, ref. 2, p. 8.

¹³⁹ H. G. Floss, G. P. Basmadjian, M. Tchong, D. Gröger, and D. Erge, *Lloydia*, 1971, **34**, 446.

¹⁴⁰ H. G. Floss, G. P. Basmadjian, M. Tchong, C. Spalla, and A. Minghetti, *Lloydia*, 1971, **34**, 442.

¹⁴¹ M. Abe, T. Ohashi, S. Ohmoto, and T. Tabuchi, *Agric. and Biol. Chem. (Japan)*, 1971, **35**, A1; R. B. Herbert, in ref. 5, p. 34.

¹⁴² T. Ohashi, H. Takahashi, and M. Abe, *Nippon Nogei Kagaku Kaishi*, 1972, **46**, 535; R. B. Herbert, in ref. 4, p. 33.

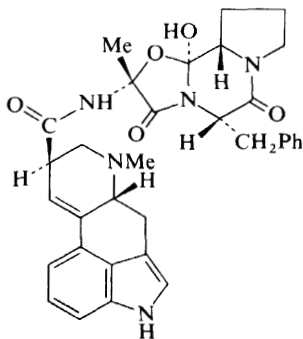

Ergotamine (133)

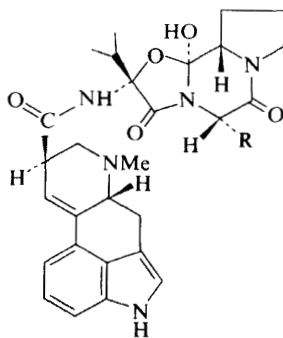
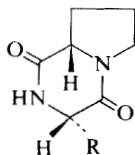
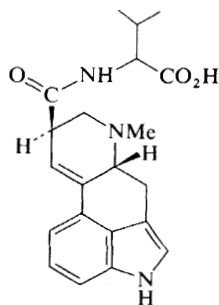
Ergocryptine (134) R = Buⁱ
Ergocornine (135) R = Prⁱ(136) R = Buⁱ
(137) R = CH₂Ph

(138)

L-Valyl-L-valyl-L-proline was incorporated into ergocornine (135) only after breakdown into its constituent amino-acids.¹⁴³ These negative results have led to the suggestion¹⁴³ that formation of the peptidic fragment and linkage with lysergic acid occurs on a multi-enzyme complex so that at no stage are there any free peptidic intermediates.

Dimethylallyltryptophan (139) has been identified as the first intermediate after tryptophan in ergot alkaloid biosynthesis.¹⁴⁴ In experiments with a *Claviceps* species, clavicipitic acid (140)¹⁴⁵ was identified as a major product formed from (139).¹⁴⁶ (The enzyme catalysing this transformation was identified in both the supernatant and microsomal fractions; oxygen is necessary for the reaction but cytochrome P-450 does not appear to be involved.) But radioactive clavicipitic acid was found to be a much less efficient precursor than (139) for elymoclavine and thus is in all probability not an intermediate in ergot alkaloid biosynthesis.¹⁴⁶

¹⁴³ H. G. Floss, M. Tchong-Lin, H. Kobel, and P. Stadler, *Experientia*, 1974, **30**, 1369.

¹⁴⁴ H. Plieninger, R. Fischer, and V. Liede, *Annalen*, 1964, **672**, 223; J. E. Robbers and H. G. Floss, *Arch. Biochem. Biophys.*, 1968, **126**, 967; S. Agurell and J.-E. Lindgren, *Tetrahedron Letters*, 1968, 5127; R. B. Herbert, in ref. 5, p. 31.

¹⁴⁵ G. S. King, P. G. Mantle, C. A. Szczyrbak, and E. S. Waight, *Tetrahedron Letters*, 1973, 215; J. E. Robbers and H. G. Floss, *ibid.*, 1969, 1857.

¹⁴⁶ R. S. Bajwa, R.-D. Kohler, M. S. Saini, M. Cheng, and J. A. Anderson, *Phytochemistry*, 1975, **14**, 735.

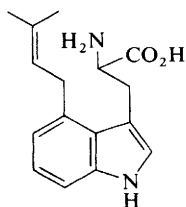

(139)

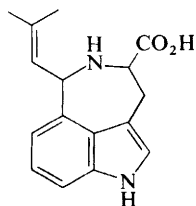

(140)

The known^{147,148} stimulation of ergot alkaloid production by tryptophan has been closely studied in *Aspergillus fumigatus*:¹⁴⁹ L-tryptophan had a greater effect than the D-isomer. Several other indole derivatives had little or no effect whereas others caused a decrease in yield (*cf.* ref. 148 for similar results). Addition of tryptophan before alkaloid production had commenced was found to result in the most marked increase in alkaloid yield.¹⁴⁹

Gramine.—Investigation of the biosynthesis of gramine (141) in germinating barley (Gramineae) has revealed that this alkaloid is formed from tryptophan with loss of C-1 and C-2 of the side chain.¹⁵⁰ Recently [^{3-¹⁴C}]tryptophan was found to be incorporated into gramine (141) in a plant from a different family [*Lupinus hartwegii* (Leguminosae)] with specific labelling of the methylene group.¹⁵¹ This result is

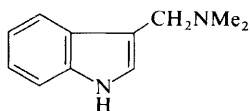

(141)

similar to that obtained in germinating barley, and implies that gramine biosynthesis probably follows a course which is independent of plant species. In the experiments¹⁵¹ with *L. hartwegii* radioactive indole-3-aldehyde was isolated and from the weight of metabolite present in plants of different ages it was concluded that indole-3-aldehyde might be a metabolite of gramine.

Terpenoid Indole Alkaloids.—Vincoside (142), but not its C-3 epimer, is implicated as an intermediate in the biosynthesis of terpenoid indole alkaloids.^{152,153} This is paradoxical since at C-3 (142) is of opposite configuration^{153,154} to the next intermediate, geissoschizine (143), and is particularly puzzling since the proton at this

¹⁴⁷ K. K. Rao, V. P. Patel, and B. Patel, *Indian J. Exp. Biol.*, 1974, **12**, 76; W. A. Taber and L. C. Vining, *Canad. J. Microbiol.*, 1958, **4**, 611; J. D. Bu'Lock and J. G. Barr, *Lloydia*, 1968, **31**, 342.

¹⁴⁸ L. C. Vining, *Canad. J. Microbiol.*, 1970, **16**, 473.

¹⁴⁹ K. K. Rao and V. P. Patel, *Lloydia*, 1974, **37**, 608.

¹⁵⁰ E. Leete and L. Marion, *Canad. J. Chem.*, 1953, **31**, 1195; D. O'Donovan and E. Leete, *J. Amer. Chem. Soc.*, 1963, **85**, 461; D. Gross, H. Lehmann, and H. R. Schütte, *Tetrahedron Letters*, 1971, 4047; R. B. Herbert, in ref. 3, p. 10.

¹⁵¹ E. Leete, *Phytochemistry*, 1975, **14**, 471.

¹⁵² A. R. Battersby, A. R. Burnett, E. S. Hall, and P. G. Parsons, *Chem. Comm.*, 1968, 1582.

¹⁵³ A. R. Battersby, in ref. 1, p. 31; J. Staunton, in ref. 2, p. 1.

¹⁵⁴ K. T. D. De Silva, G. N. Smith, and K. E. H. Warren, *Chem. Comm.*, 1971, 905; W. P. Blackstock, R. T. Brown, and G. K. Lee, *ibid.*, p. 910.

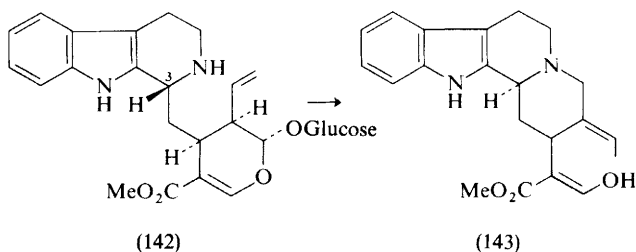

centre is retained during inversion. A likely solution to the riddle comes from synthetic work on Corynanthé-type alkaloids where it was found that during hydrogenation, which removed a benzyl protecting group from (144), the (145) being formed underwent spontaneous reaction to give (manifestly after further reduction) (147), and an epimeric mixture (148) in which the 3β -isomer predominated.¹⁵⁵

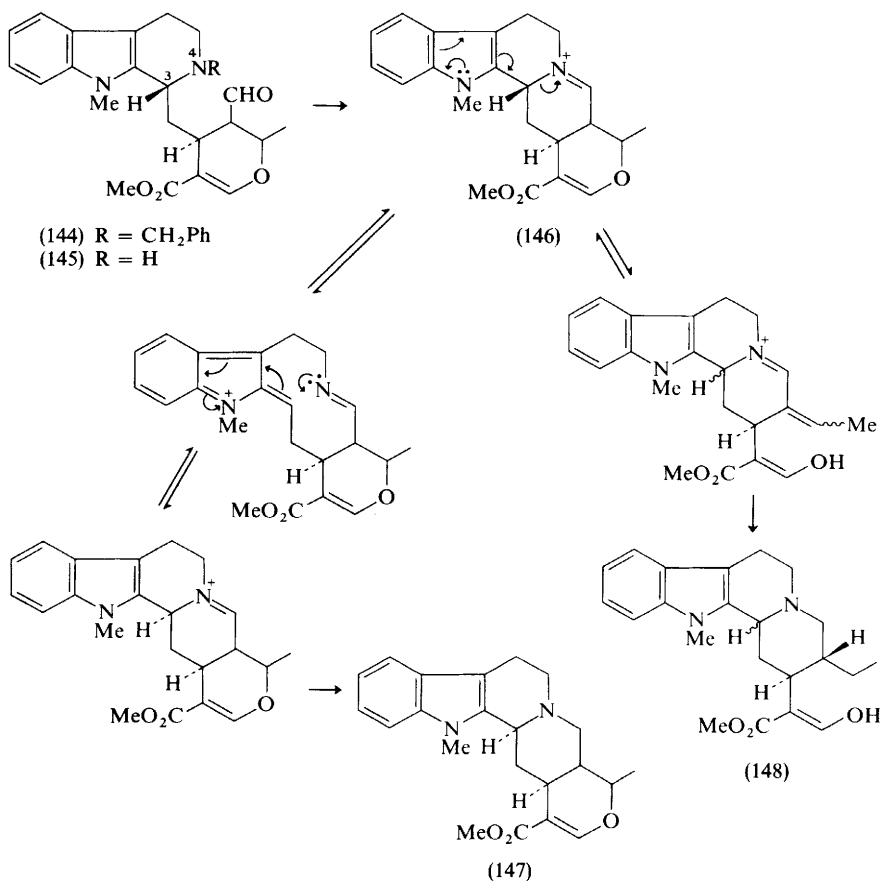

Scheme 16

¹⁵⁵ R. T. Brown, C. L. Chapple, R. Platt, and H. Spencer, *J.C.S. Chem. Comm.*, 1974, 929.

Inversion at C-3 is apparent in the formation of two of these products and deuteration studies affirmed that the hydrogen at C-3 was retained in product formation.

These observations have been rationalized in terms of the mechanism illustrated in Scheme 16.¹⁵⁵ The facility with which the reaction occurs suggests that reactions of this type should be readily available during alkaloid biosynthesis, and the inversion at C-3 in the biotransformation of (142) into (143) may well involve an immonium salt of the type (146).

Although it can be presumed that dimeric alkaloids like vincalukoblastine (149) are formed *in vivo* by joining bases like catharanthine (150) and vindoline (151) together, biosynthetic evidence for such a view has been lacking. This contrasts with the biosynthesis of (150) and (151), which is fairly well understood.^{153,156}

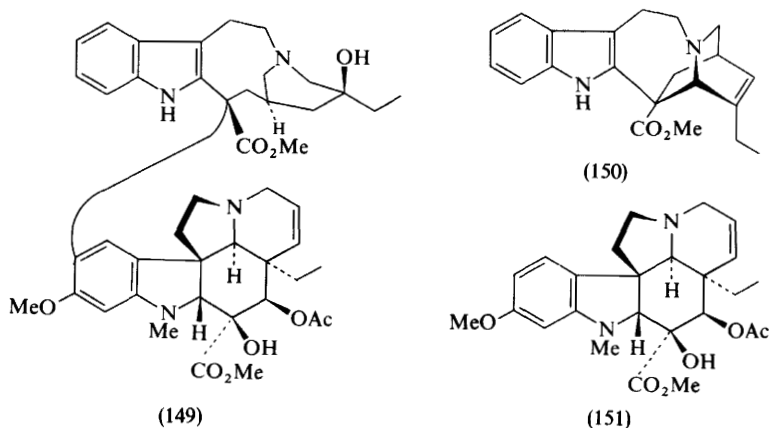

Incorporation of [3,6-³H₃,methoxy-¹⁴C]loganin (152) into (150) and (151) occurs apparently with stereospecific retention of tritium;¹⁵⁷ the specific incorporation of (152) into the two alkaloids was the same [after allowance was made for the different amounts of tritium which were lost¹⁵⁷ on incorporation of the unevenly labelled loganin precursor into (150) and (151)].¹⁵⁸

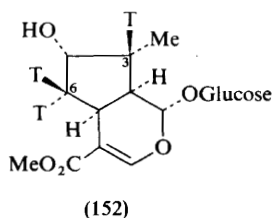

Incorporation of (152) into vincalukoblastine (149) was apparently specific and the ³H/¹⁴C ratio was the same as the average of the values for (150) and (151).¹⁵⁸

¹⁵⁶ R. B. Herbert, in ref. 3, p. 1; ref. 4, p. 30; G. A. Cordell, *Lloydia*, 1974, **37**, 219.

¹⁵⁷ A. R. Battersby, C. R. Hutchinson, N. D. Westcott, and R. A. Larson, manuscript in preparation; quoted in ref. 158.

¹⁵⁸ P. E. Daddona and C. R. Hutchinson, *J. Amer. Chem. Soc.*, 1974, **96**, 6806.

Given the similar level of radioactivity in these two alkaloids this is the ratio to be expected if they are joined together to give (149). It was argued¹⁵⁸ that a compound earlier in the pathway is a more likely precursor for at least one half of (149) but since nothing is known of the pool size and hence the specific activity of such an intermediate no conclusion can be reached about its involvement in vincalukoblastine biosynthesis. (If the specific activity of the two 'halves' is not the same, the $^3\text{H}/^{14}\text{C}$ ratio of the dimer must be a weighted average. It is pool sizes not rates, as suggested, which must be considered. In any event the rate of dimerization must obviously be the same from both halves.) Of course the $^3\text{H}/^{14}\text{C}$ ratio observed for vincalukoblastine may be a fortuitous average so the role of (150) and (151) is in any case still uncertain. More definitive results are awaited, but it may be noted that (150) has failed to act as a precursor for vincalukoblastine.¹⁵⁹

Research on the biosynthesis of oxindole alkaloids in *Mitragyna* species has allowed some conclusions to be reached on their interrelationships and their sites of synthesis in the plant.¹⁶⁰ These alkaloids are formed by modification of the terpenoid indole skeleton.

Camptothecin.—In accord with the suggested relationship between camptothecin (155) and the terpenoid indole alkaloids,¹⁶¹ radioactive tryptophan, mevalonate, secologanin, and vincoside/isovincoside [as (153)] were incorporated into (155).¹⁶² However, geissoschizine (143), the next intermediate after vincoside (142) in the biosynthesis of terpenoid indole alkaloids,¹⁵³ was only incorporated at a much lower level than vincoside/isovincoside so it follows that the branch point for camptothecin biosynthesis is at vincoside/isovincoside.

The C-3 epimeric lactams [as (154)] were proposed¹⁶² as potential intermediates after vincoside/isovincoside, and in support the lactam (154), synthesized from radioactive isovincoside (153), was found to be an efficient precursor for camptothecin (155); the epimeric lactam formed from radioactive vincoside (142) was only incorporated to an insignificant extent. These results stand in contrast to those for the terpenoid indole alkaloids where vincoside but not isovincoside has been found to be a biosynthetic intermediate.^{152,153}

Convincing support for the biosynthesis of camptothecin (155) proceeding *via* the (3*S*)-lactam (154) comes from feeding experiments with the two lactams [as (154)] labelled with ^{13}C at C-5.¹⁶² Only the (3*S*)-isomer was incorporated into (155), with enrichment of C-5 only, which is consistent with the pathway illustrated in Scheme 17. The use of ^{13}C -labelled material in this study is notable as generally the low levels of incorporation found in plants preclude the use of precursors labelled in this way. However, ^{13}C -labelled precursors can find use where satisfactory incorporations can be obtained and the labelled material is not diluted substantially by unlabelled material, as here and in the case of colchicine biosynthesis (see above). No doubt further applications in the study of alkaloid biosynthesis will appear in the future.

¹⁵⁹ A. I. Scott, J. D. Michael, and C. L. Yeh, unpublished work quoted in ref. 158.

¹⁶⁰ E. J. Shellard and P. J. Houghton, *Planta Medica*, 1974, **25**, 80; *ibid.*, 1973, **24**, 341.

¹⁶¹ E. Wenkert, K. G. Dave, R. G. Lewis, and P. W. Sprague, *J. Amer. Chem. Soc.*, 1967, **89**, 6741; E. Winterfeldt, *Annalen*, 1971, **745**, 23.

¹⁶² C. R. Hutchinson, A. H. Heckendorf, P. E. Daddona, E. Hagaman, and E. Wenkert, *J. Amer. Chem. Soc.*, 1974, **96**, 5609.

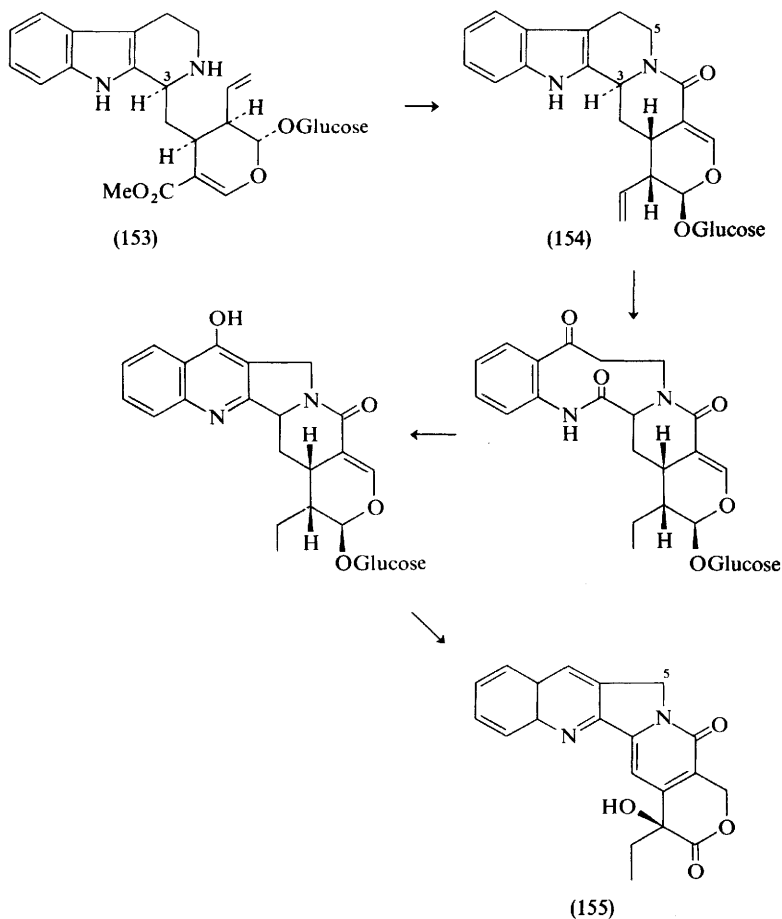

Scheme 17

5 Miscellaneous Bases of Aromatic Origin

Gliotoxin and Mycelianamide.—Results relating to the fate of the side-chain hydrogen atoms of phenylalanine in incorporation into gliotoxin (156), which were published in preliminary form,¹⁶³ are now available in a full paper.¹⁶⁴ Contrary to the preliminary report¹⁶³ it is the *pro-R*- β -methylene proton of phenylalanine which undergoes exchange and not the *pro-S* hydrogen.¹⁶⁴ This exchange process, which is independent of gliotoxin biosynthesis, results in retention of configuration at C-3 of phenylalanine. Moreover the proton at C-2 does not migrate to C-3. In fact, owing no doubt to rapid reversible transamination, very little tritium from [2-³H]phenylalanine appeared in either protein phenylalanine or gliotoxin.

¹⁶³ J. D. Bu'Lock, A. P. Ryles, N. Johns, and G. W. Kirby, *J.C.S. Chem. Comm.*, 1972, 100; R. B. Herbert, in ref. 3, p. 12.

¹⁶⁴ N. Johns, G. W. Kirby, J. D. Bu'Lock, and A. P. Ryles, *J.C.S. Perkin I*, 1975, 383.

Further investigation of the biosynthesis of gliotoxin has shown that although *cyclo*-L-phenylalanyl-L-seryl (157) was apparently able to permeate the mycelium of *Penicillium terlikowskii*, it was not incorporated into gliotoxin (156) under conditions when phenylalanine was.¹⁶⁵ Similar negative results were obtained for mycelianamide (158) in *P. patulum* with *cyclo*-L-alanyl-L-tyrosyl (159) and *cyclo*-L-alanyl-D-tyrosyl which were also able to permeate the mycelium. In contrast [$1-^{14}\text{C}$]tyrosine was specifically incorporated with high efficiency (there was no significant difference in the efficiency with which the D- and L-isomers of tyrosine were utilized).¹⁶⁵

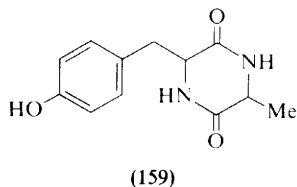
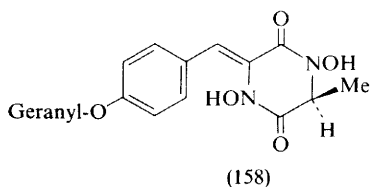
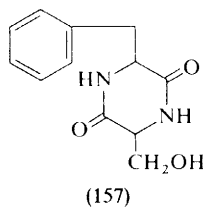
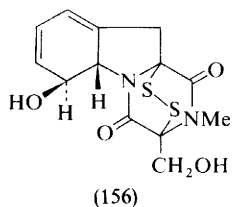

The failure of the *cyclo*-alanyltyrosyls to act as mycelianamide precursors contrasts with the observed incorporation of the cyclic dipeptide (161) into brevianamide A (160) in *P. brevicompactum*¹⁶⁶ and similar results with the related metabolite echinulin.¹⁶⁷ This difference was attributed to differences in the number of reactions which take place on an enzyme complex before exchange can occur with unbound material.¹⁶⁵ It may be noted that the early stages in the biosynthesis of cyclophenin and cyclophenol, which are also modified cyclic dipeptides, appear to involve enzyme-bound intermediates.¹⁶⁸

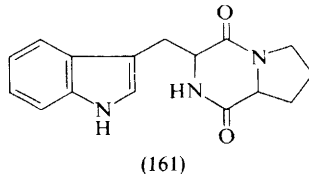
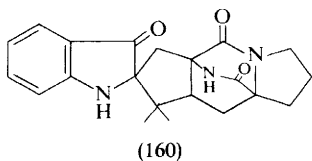

¹⁶⁵ J. C. MacDonald and G. P. Slater, *Canad. J. Biochem.*, 1975, **53**, 475.

¹⁶⁶ J. Baldas, A. J. Birch, and R. A. Russell, *J.C.S. Perkin I*, 1974, 50; R. B. Herbert, in ref. 5, p. 26.

¹⁶⁷ G. P. Slater, J. C. MacDonald, and R. Nakashima, *Biochemistry*, 1970, **9**, 2886; R. B. Herbert, in ref. 4, p. 29.

¹⁶⁸ J. Framm, L. Nover, A. El Azzouny, H. Richter, K. Winter, S. Werner, and M. Luckner, *European J. Biochem.*, 1973, **37**, 78; R. B. Herbert, in ref. 5, p. 39.

Amaryllidaceae Alkaloids.—*O*-Methylnorbelladine (162) and vittatine (163) are implicated as intermediates in the biosynthesis of narciclasine (164).^{169,170} Loss of the two-carbon bridge from the latter could plausibly occur by a retro-Prins reaction on 11-hydroxyvittatine (165) to give (166), as shown in Scheme 18, analogy for hydroxylation of (163) coming from the biosynthesis of the related alkaloid haemanthamine.¹⁷¹ Strong support for this pathway to narciclasine (164) was obtained when it was shown that tritiated (165) was an efficient precursor for this alkaloid.¹⁷² It is to be noted that collapse of a similar β -hydroxy-amine is proposed for the biosynthesis of colchicine.¹²⁵

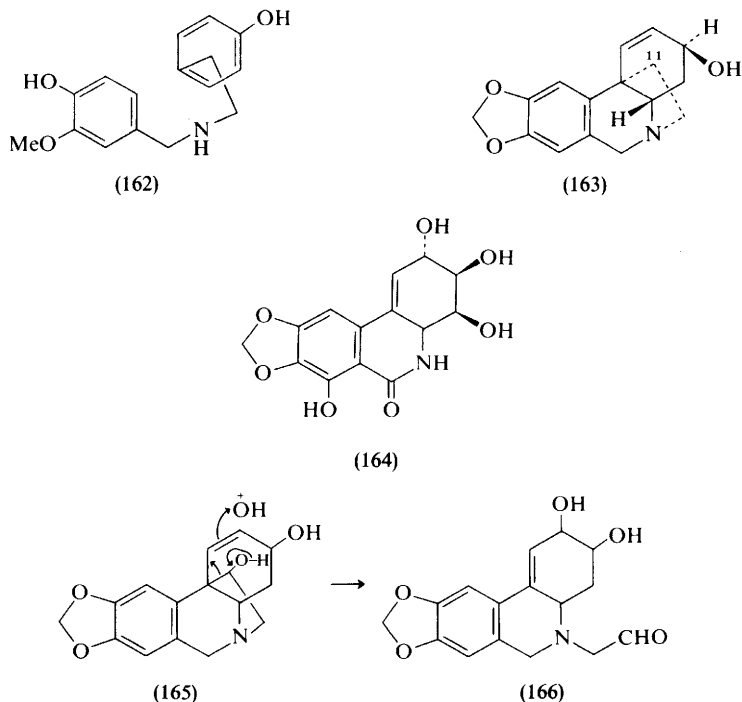

Scheme 18

Furoquinoline Alkaloids.—Definitive studies on the biosynthesis of furoquinoline alkaloids which had been reported in preliminary form^{173–176} have now appeared as

¹⁶⁹ C. Fuganti, J. Staunton, and A. R. Battersby, *Chem. Comm.*, 1971, 1154; J. Staunton, in ref. 2, p. 16.

¹⁷⁰ C. Fuganti and M. Mazza, *Chem. Comm.*, 1971, 1388; *J.C.S. Chem. Comm.*, 1972, 239; R. B. Herbert, in ref. 3, p. 21.

¹⁷¹ A. R. Battersby, J. E. Kelsey, and J. Staunton, *Chem. Comm.*, 1971, 183; J. Staunton, in ref. 2, p. 20.

¹⁷² C. Fuganti, *Gazzetta*, 1973, **103**, 1255.

¹⁷³ J. F. Collins and M. F. Grundon, *Chem. Comm.*, 1969, 621; R. B. Herbert, in ref. 1, p. 12.

¹⁷⁴ M. F. Grundon and K. J. James, *Chem. Comm.*, 1971, 1311; R. B. Herbert, in ref. 3, p. 34.

¹⁷⁵ J. F. Collins, W. J. Donnelly, M. F. Grundon, D. M. Harrison, and C. G. Spyropoulos, *J.C.S. Chem. Comm.*, 1972, 1029; R. B. Herbert, in ref. 4, p. 43.

¹⁷⁶ M. F. Grundon, D. M. Harrison, and C. G. Spyropoulos, *J.C.S. Chem. Comm.*, 1974, 51; R. B. Herbert, in ref. 5, p. 35.

full papers.¹⁷⁷⁻¹⁷⁹ The reader is referred to previous Reports for full discussion of this work. Mentioned should be made here, though, of previously unpublished observations.

Introduction of the prenyl residue on to the quinoline skeleton can apparently occur with either a hydroxy- or a methoxy-group at C-4, for (167) and (168) are equally efficient precursors for dictamnine (172) and (174).¹⁷⁷ Methylation of the oxygen function at C-2 as well, however, blocks further reaction, as seen in the isolation of inactive alkaloid after feeding [2,4-¹⁴C₂]-2,4-dimethoxyquinoline. The prenylquinolines (169) and (170) are also equally efficient precursors for dictamnine (172) and (174), and are thus presumably successive intermediates in furoquinoline biosynthesis;¹⁷⁷ it is known that the methyl group of (170) is retained in the genesis of skimmianine (173).^{176,179}

2,3-Dihydrodictamnine is a very poor precursor for dictamnine.¹⁷⁷

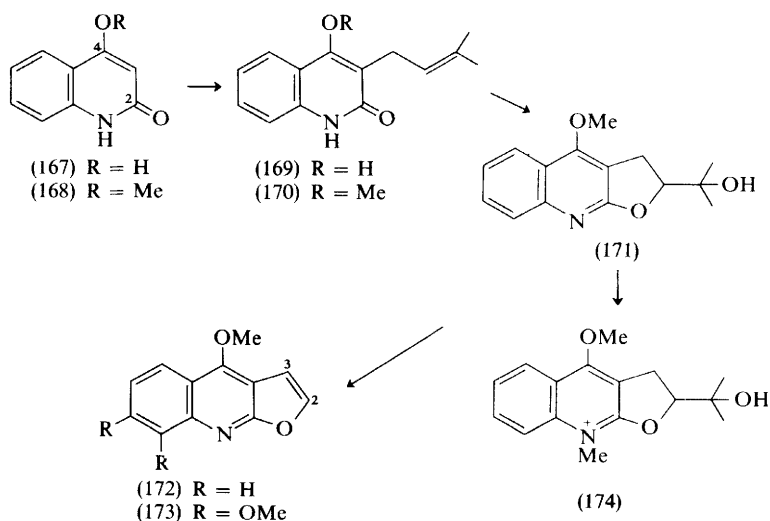

Securinine.—Carbon atoms 6—13 of securinine (175) are derived from tyrosine.¹⁸⁰ Transformation of this amino-acid into securinine involves loss of one of the C-3

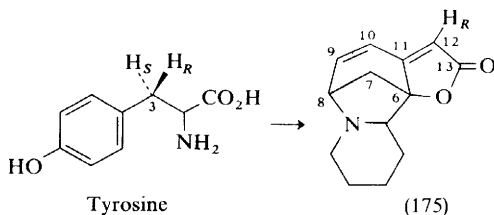

¹⁷⁷ J. F. Collins, W. J. Donnelly, M. F. Grundon, and K. J. James, *J.C.S. Perkin I*, 1974, 2177.

¹⁷⁸ M. F. Grundon, D. M. Harrison, and C. G. Spyropoulos, *J.C.S. Perkin I*, 1974, 2181.

¹⁷⁹ M. F. Grundon, D. M. Harrison, and C. G. Spyropoulos, *J.C.S. Perkin I*, 1975, 302.

¹⁸⁰ R. J. Parry, *Tetrahedron Letters*, 1974, 307; U. Sankawa, Y. Yamasaki, and Y. Ebizuka, *ibid.*, p. 1867; R. B. Herbert, in ref. 5, p. 10.

hydrogen atoms (C-3 becomes C-12 in securinine) and the results of recent experiments¹⁸¹ with (3*R*S)-, (3*R*)-, and (3*S*)-[3-¹⁴C,3-³H]-DL-tyrosine demonstrate that (a) hydrogen removal is stereospecific and (b) it is the 3-*pro-S* hydrogen atom which is lost. (In the conversion of tyrosine into securinine, C-2 of the amino acid is oxidized to a carbonyl group which by enolization may account for the additional tritium loss noted in these experiments.)

Betalains.—The dihydropyridine moiety of the betalains, e.g. betanin (177), has been shown to be generated from dopa,¹⁸² modification of which entails extra-diol cleavage of its aromatic ring.¹²⁰ The general assumption that betalamic acid (176) is an intermediate in the biosynthesis of the dihydropyridine fragment of the betalains is supported by its isolation from betalain-synthesizing plants.^{183,184}

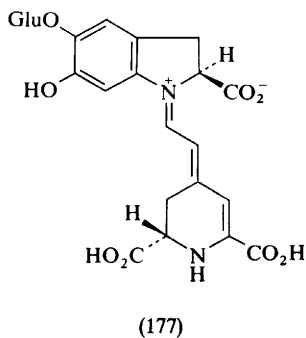
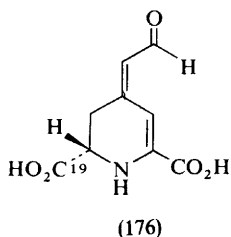

Further evidence implicating betalamic acid (176) in betalain biosynthesis comes from a study of the biosynthesis of the acid itself in *Portulaca grandiflora*.¹⁸⁵ Both [2-¹⁴C]- and [1-¹⁴C]-DL-dopa were incorporated into betalamic acid. Degradation of the betalamic acid (176) derived from [1-¹⁴C]dopa showed that the incorporation was specific, almost all the activity being confined to the carboxy-groups (and presumably only C-19 is labelled). This pattern of dopa incorporation is the same as for the betalains, a requirement if (176) is to be an intermediate in betalain biosynthesis.

The effect of light in combination with exogenous precursors on amaranth biosynthesis has been studied,¹⁸⁶ as has the effect of cyclic 3',5'-adenosine monophosphate.¹⁸⁷

Demethyltomaymycin.—11-Demethyltomaymycin (178) resembles in structure another microbial metabolite, anthramycin (179), whose biosynthesis has been studied.¹⁸⁸ As might be expected (178) turns out to be formed along a related

¹⁸¹ R. J. Parry, *J.C.S. Chem. Comm.*, 1975, 144.

¹⁸² E. Dunkelblum, H. E. Miller, and A. S. Dreiding, *Helv. Chim. Acta*, 1972, **55**, 642; R. B. Herbert, in ref. 3, p. 8; and refs. cited.

¹⁸³ L. Kimler, R. A. Larson, L. Messenger, J. B. Moore, and T. J. Mabry, *Chem. Comm.*, 1971, 1329.

¹⁸⁴ T. J. Mabry, L. Kimler, and R. A. Larson, *Z. physiol. Chem.*, 1972, **353**, 127.

¹⁸⁵ C. Chang, L. Kimler, and T. J. Mabry, *Phytochemistry*, 1974, **13**, 2771.

¹⁸⁶ C. J. French, R. C. Peckel, and H. Smith, *Phytochemistry*, 1974, **13**, 1505; M. G. de Nicola, V. Amico, S. Sciuto, and M. Piattelli, *ibid.*, 1975, **14**, 479.

¹⁸⁷ M. G. de Nicola, V. Amico, and M. Piattelli, *Phytochemistry*, 1975, **14**, 989.

¹⁸⁸ L. H. Hurley and M. Zmijewski, *J.C.S. Chem. Comm.*, 1974, 337; R. B. Herbert, in ref. 5, p. 40.

pathway.¹⁸⁹ Thus L-tryptophan, L-methionine, L-tyrosine, and L-dopa were all efficiently utilized for the production of (178). Tyrosine (and methionine) serves as the source for the 'acrylamide proline' residue of anthramycin (179) (shown with heavy bonding) and it was presumed therefore that the related residue in (178) also arose similarly. Scission of the aromatic ring of tyrosine must precede its incorporation into this residue in (178), and the bond across which fission occurs has been

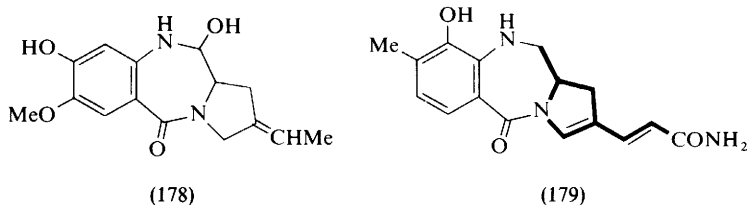

determined in further experiments. [$1\text{-}^{14}\text{C}$]Tyrosine with tritium labels at C-3' and C-5' gave (178) with 50% loss of tritium (incorporation *via* dopa involves obligatory loss of half the tyrosine tritium). The remaining tritium was shown to be present on the C-methyl group, which was also shown not to be labelled by [$^{14}\text{CH}_3$]methionine. These results were interpreted as being consistent only with extra-diol cleavage [dotted line (a) in (180)] and the attendant pathway is illustrated (Scheme 19, where the alternative evidently non-operative pathways are also shown). Similar extra-diol cleavage has been deduced for anthramycin (179)^{188,190} and the betalains.¹²⁰

Actinomycin.—The phenoxazinone skeleton of the actinomycins (181) has been shown to derive from two molecules of tryptophan *via* 3-hydroxy-4-methylanthranilic acid (185),^{191–193} methionine serving as the source of the aromatic methyl groups.^{191,194} Depression of the incorporation of radioactive tryptophan into actinomycin by kynurenine (182) and 3-hydroxy-4-methylkynurenine (184)¹⁹⁵ indicated that (182) and (184) could well be biosynthetic intermediates. In contrast 3-hydroxykynurenine (183) was found to have little or no effect on tryptophan incorporation,^{193,195} thus casting doubt on its participation in actinomycin biosynthesis. However, both [^3H]kynurenine [as (182)] and [^3H]-3-hydroxykynurenine [as (183)] have recently been shown to be efficient precursors for actinomycin in *Streptomyces antibioticus*.¹⁹⁶ 3-Hydroxykynurenine (183) is therefore implicated in actinomycin biosynthesis and further substantive evidence is provided for the pathway tryptophan \rightarrow (182) \rightarrow (183) \rightarrow (184) \rightarrow (185) \rightarrow actinomycin (181).

Aromatic methylation involves transfer of a methyl group from methionine. The mechanism of this transfer in actinomycin biosynthesis was examined by feeding [$\text{Me-}^2\text{H}_3$]methionine to *S. antibioticus*.¹⁹⁶ The actinomycin isolated contained tri- and hexa-deuterio-species, from which it follows that all the hydrogens of the methyl

¹⁸⁹ L. H. Hurley, C. Gairola, and M. J. Zmijewski, jun., *J.C.S. Chem. Comm.*, 1975, 120.

¹⁹⁰ L. Hurley, M. Zmijewski, and C. J. Chang, work submitted for publication, quoted in ref. 189.

¹⁹¹ A. Sivak, M. L. Meloni, F. Nobili, and E. Katz, *Biochim. Biophys. Acta*, 1962, **57**, 283.

¹⁹² E. Katz and H. Weissbach, *J. Biol. Chem.*, 1962, **237**, 882; E. E. Golub, M. A. Ward, and J. S. Nishimura, *J. Bacteriol.*, 1969, **100**, 977.

¹⁹³ H. Weissbach, B. G. Redfield, V. Beaven, and E. Katz, *J. Biol. Chem.*, 1965, **240**, 4377.

¹⁹⁴ A. J. Birch, D. W. Cameron, P. W. Holloway, and R. W. Rickards, *Tetrahedron Letters*, 1960, No. 25, p. 26.

¹⁹⁵ D. Perlman, S. Otani, K. L. Perlman, and J. E. Walker, *J. Antibiotics*, 1973, **26**, 289.

¹⁹⁶ R. B. Herbert, *Tetrahedron Letters*, 1974, 4525.

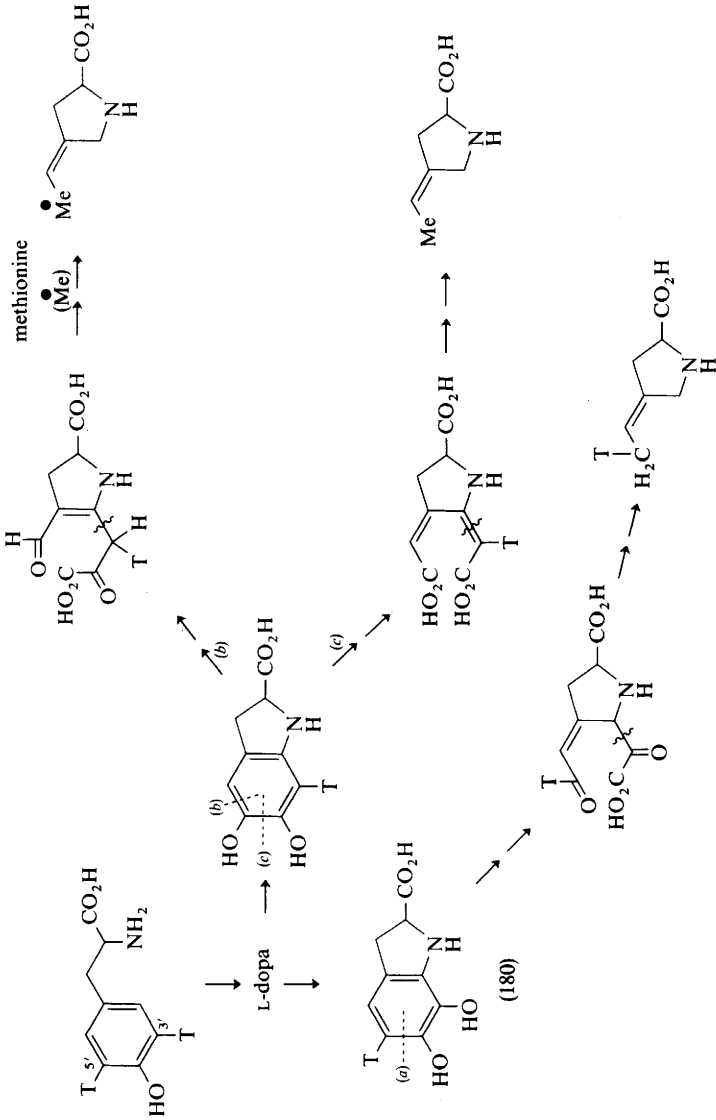

Scheme 19

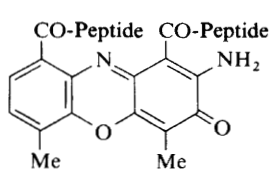

(181)

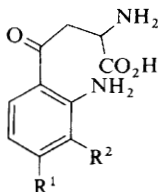

- (182) $R^1 = R^2 = H$
 (183) $R^1 = H, R^2 = OH$
 (184) $R^1 = Me, R^2 = OH$

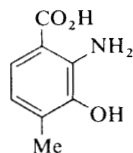

(185)

group transferred from methionine are retained (a hypothetical ylide mechanism¹⁹⁶ is thereby excluded) and further proof is provided that both aromatic methyl groups originate from methionine.

Cytochalasins.—The cytochalasins are a group of microbial metabolites of biological interest.¹⁹⁷ Biosynthetic experiments with radioactively labelled materials have indicated that cytochalasin B (186) is formed from phenylalanine (the carboxy-group being retained), nine acetate units, and two C_1 units which derive from methionine; label from malonate was also incorporated.¹⁹⁸ From these results, which are summarized in (188), it was suggested that cytochalasin B is derived from a C_{18} (or C_{16} , if C-19 and C-19a represent a separate acetate unit) polyketide chain, initiated by acetate and propagated by malonate.

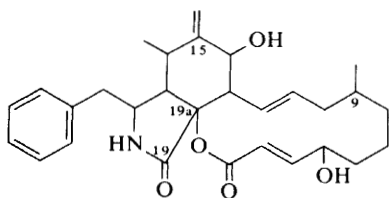

(186)

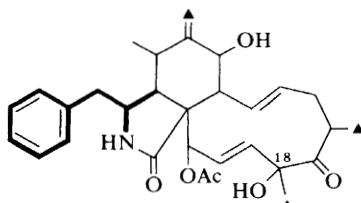

(187)

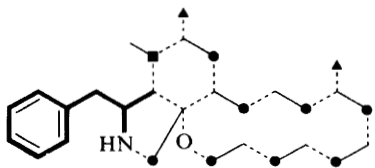

(188)

Phenylalanine: heavy bonding
 Acetate (starter): —■
 Acetate/malonate: —●
 C_1 unit from methionine: ▲

Investigation¹⁹⁹ of the biosynthesis of cytochalasin D (187) has revealed a pattern of biosynthesis similar to that of (186). Thus phenylalanine and methionine were found to be precursors. Of particular interest was the observation that methionine provided the C-18 methyl group, which could *a priori* have arisen perhaps by the incorporation of a propionate unit into the polyketide chain, although it is known

¹⁹⁷ M. Binder and C. Tamm, *Angew. Chem. Internat. Edn.*, 1973, **12**, 370.

¹⁹⁸ M. Binder, J.-R. Kiechel, and C. Tamm, *Helv. Chim. Acta*, 1970, **53**, 1797.

¹⁹⁹ C.-R. Lebet and C. Tamm, *Helv. Chim. Acta*, 1974, **57**, 1785.

that neither the C-9 methyl nor the C-15 methylene group of (186) originates from propionate.¹⁹⁸ The results with acetate and malonate were inconclusive.¹⁹⁹

Certainty on the manner in which acetate is incorporated into both cytochalasin B (186) and cytochalasin D (187) comes from studies using ¹³C-labelled acetate.²⁰⁰ The definitive results obtained are in agreement with the previous data as far as they went and are consistent with the pathway illustrated in Scheme 20.

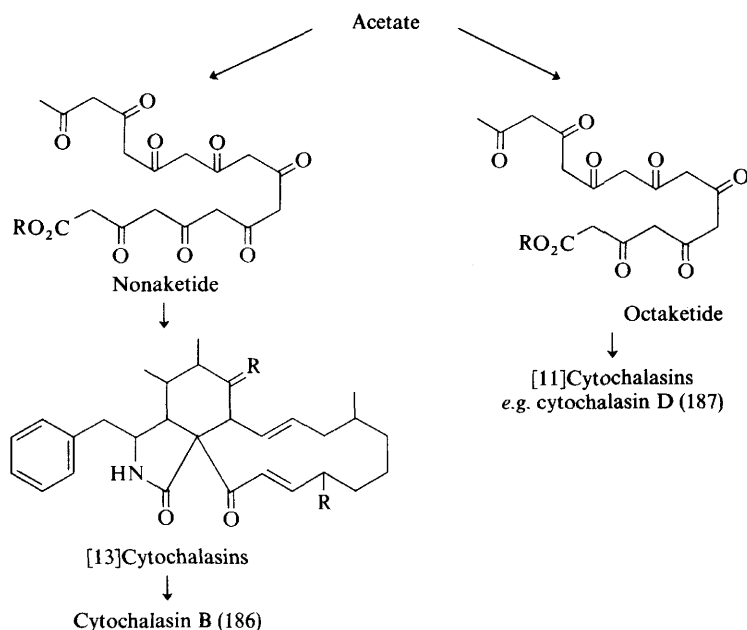

Scheme 20

6 Miscellaneous Bases of Aliphatic Origin

Mitomycin and Rifamycin.—Common to antibiotics like mitomycin C (190) and rifamycin S (193) is a C₇N unit (shown in heavy bonding)²⁰¹ which, it has been supposed, derives from carbohydrate metabolism. Recent experiments on mitomycin and rifamycin biosynthesis have been directed to discovering more precisely what the intermediates in the generation of this unit are.

In *Streptomyces verticillatus* radioactive glucose has been found to label both the C₇N unit of mitomycin C and the remaining atoms, which form a C₆N unit.²⁰² More directly D-glucosamine is the source of this C₆N unit (C-1, C-2, C-3, C-9, C-9a, and C-10 and the nitrogen atom of the aziridine ring).^{201,203} In order to gain a

²⁰⁰ W. Graf, J.-L. Roberts, J. C. Vederas, C. Tamm, P. H. Solomon, I. Miura, and K. Nakanishi, *Helv. Chim. Acta*, 1974, **57**, 1801.

²⁰¹ U. Hornemann, J. P. Kehrer, C. S. Nunez, and R. L. Ranieri, *J. Amer. Chem. Soc.*, 1974, **96**, 320; R. B. Herbert, in ref. 5, p. 52.

²⁰² G. S. Bezanson and L. C. Vining, *Canad. J. Biochem.*, 1971, **49**, 911.

²⁰³ U. Hornemann, J. P. Kehrer, C. S. Nunez, R. L. Ranieri, and Y. K. Ho, *Developments Ind. Microbiol.*, 1974, **15**, 82.

more definitive incorporation of glucose into the C₇N unit ¹⁴C-labelled glucose samples were administered with a large excess of unlabelled D-glucosamine.²⁰⁴ The results indicate that the methyl group (C-6a) of mitomycin C (190) may derive from C-3 of glucose rather than C-1 as previously thought and that glucose may be incorporated into C-6 and C-6a *via* phosphoenolpyruvate. This conclusion was supported by the observed distribution of label in mitomycin C after feeding radioactive samples of pyruvic acid. The incorporation of pyruvic acid into the C₇N unit is consistent with generation of this unit along the shikimate pathway. It is known, however, that shikimic acid (191) is not a mitomycin precursor.^{202,205} Nonetheless earlier intermediates on this pathway may still be implicated [including 3-dehydroquinic acid (189); see Scheme 21].

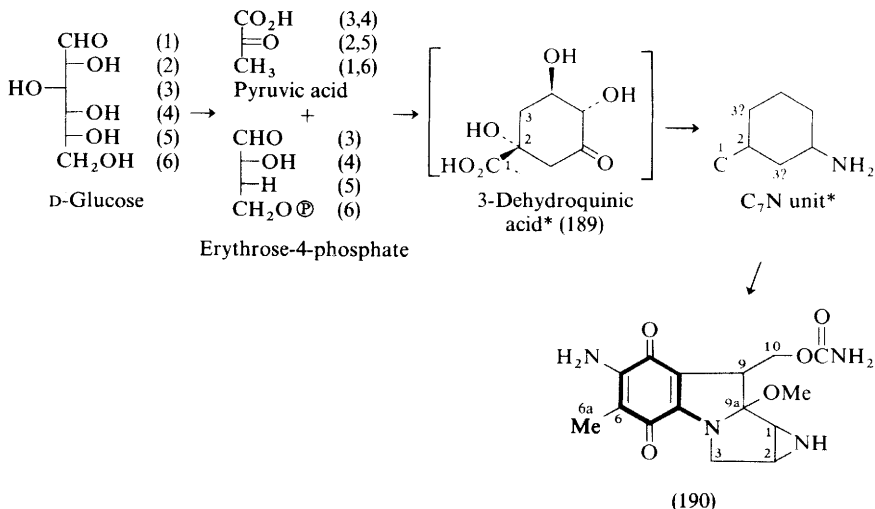

Numbers in parentheses refer to those of D-glucose

Scheme 21

Of several radioactive compounds tested as precursors of the C₇N unit of rifamycin S (193) in *Nocardia mediterranei*, [3,4-¹⁴C₂]glucose and [1-¹⁴C]glycerate were found to be substantially the best.²⁰⁶ It was suggested that both of these precursors entered the C₇N unit (in part at least) *via* the same intermediate formed as the result of entry of each into the glycolytic pathway. This intermediate was presumed to be a C₃ compound and since pyruvic acid was a very poor precursor of rifamycin S it was concluded that this compound must lie between glucose-6-phosphate and phosphoenolpyruvate (the observed labelling of the remainder of the rifamycin S molecule by labelled glucose and glycerate was evidently consistent with catabolism to acetyl-CoA after passage through the pentose phosphate pathway).

²⁰⁴ U. Hornemann, J. P. Kehrler, and J. H. Eggert, *J.C.S. Chem. Comm.*, 1974, 1045.

²⁰⁵ U. Hornemann and J. C. Cloyd, *Chem. Comm.*, 1971, 301; R. B. Herbert, in ref. 4, p. 40.

²⁰⁶ A. Karlsson, G. Sartori, and R. J. White, *European J. Biochem.*, 1974, **47**, 251.

* Numbers refer to those of pyruvic acid.

Further information was gleaned from feeding $[1-^{13}\text{C}]$ glucose.^{206,207} This compound was found to label only C-1 and C-10 of the C_7N unit, a labelling pattern which is similar to that observed²⁰⁸ in shikimic acid (191) formed from $[1-^{14}\text{C}]$ glucose. Neither shikimic acid,^{206,209a} however, nor the labelled aromatic amino-acids²⁰⁶ tested were found to be precursors for the C_7N unit of rifamycin S. This does not, of course, exclude earlier intermediates on the shikimate pathway and it was suggested²⁰⁶ that 3-dehydroquinate (189) or 3-dehydroshikimate (192) may be the key intermediate in the biosynthesis of this unit in rifamycin S (193).

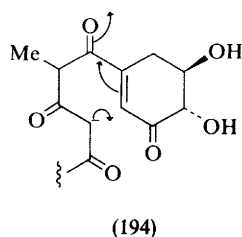
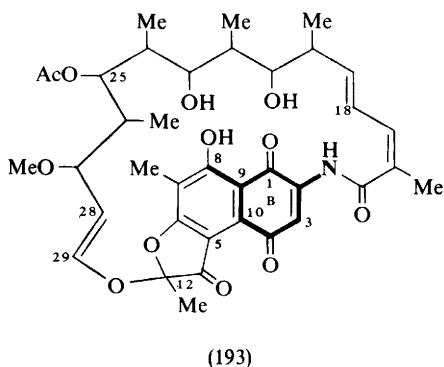
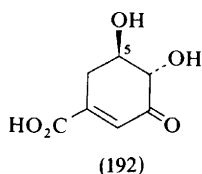
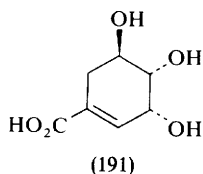

Rifamycin S derived from $[1-^{13}\text{C}]$ glycerate showed enhanced n.m.r. signals for C-3 and C-8 which is consistent with incorporation by way of intermediates on the shikimate pathway (Scheme 22).²⁰⁷ Greater enhancement of C-8 by $[1-^{13}\text{C}]$ glycerate and of C-1 by $[1-^{13}\text{C}]$ glucose was observed, compared respectively with C-3 and C-10. This indicates that C-1 derives from the methylene carbon of phosphoenolpyruvate rather than C-4 of tetrose phosphate and that C-8 derives from the carboxy-group of phosphoenolpyruvate. It follows then that C-9 and C-10 of rifamycin S (193) would be the location of the double bond of a dehydroshikimate intermediate. Michael addition to this double bond as in (194)²⁰⁷ allows completion of the naphthoquinone moiety of rifamycin S in an analogous fashion to the formation of the menaquinones.²¹⁰

Additional information has been reported²⁰⁶ on the biosynthesis of the remaining atoms of rifamycin S, previously shown²⁰⁹ to arise from acetate and

²⁰⁷ R. J. White and E. Martinelli, *F.E.B.S. Letters*, 1974, **49**, 233.

²⁰⁸ P. R. Srinivasan, H. T. Shigeura, M. Sprecher, D. B. Sprinson, and B. D. Davis, *J. Biol. Chem.*, 1956, **220**, 477.

²⁰⁹ (a) R. J. White, E. Martinelli, G. G. Gallo, G. Lancini, and P. Beynon, *Nature*, 1973, **243**, 273; (b) E. Martinelli, R. J. White, G. G. Gallo, and P. J. Beynon, *Tetrahedron Letters*, 1974, 1367; R. B. Herbert, in ref. 5, p. 53.

²¹⁰ D. J. Robins, I. M. Campbell, and R. Bentley, *Biochem. Biophys. Res. Comm.*, 1970, **39**, 1081.

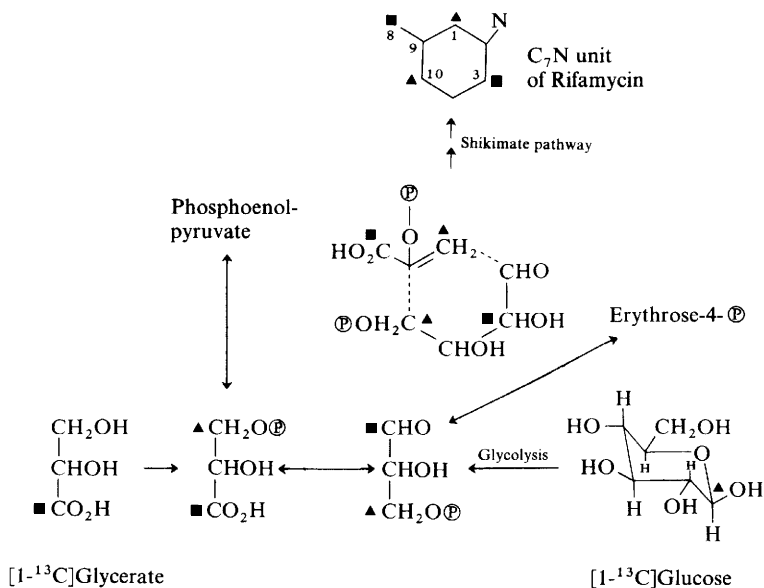

Scheme 22

propionate. These results were further supported and incorporations of labelled methylmalonate and malonate were recorded.²⁰⁶ The results with methylmalonate were similar to those obtained with propionate whereas [2- ^{13}C]malonate was found to give rise to enriched n.m.r. signals for C-5 and C-18 only, results which complement those obtained with [1- ^{13}C]- and [2- ^{13}C]-acetate;²⁰⁹ acetate alone gave rise to the acetoxy-group at C-25. It was concluded that rifamycin S (193), apart from the C₇N unit, is formed from a polyketide made up from eight methylmalonates and two malonates by linear combination in the appropriate order [see (195)], the C-25 acetoxy-group arising from acetate.

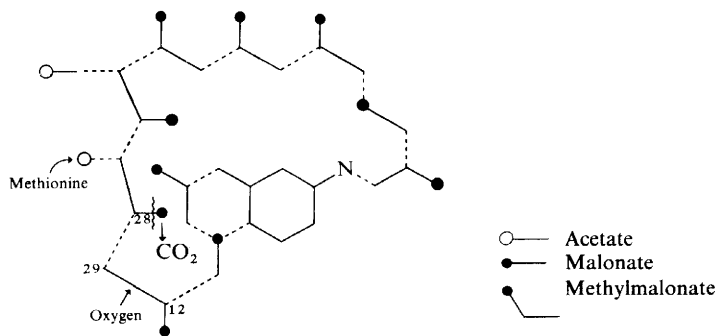

Unusual features in this pattern for rifamycin S biosynthesis are loss of the propionate-derived methyl group from C-28 and insertion of oxygen between C-12 and C-29 of a precursor (195). Important support for the correctness of these conclusions comes from the isolation, from a *N. mediterranei* mutant, of rifamycin W (196), which possesses the unmodified skeleton (195) and whose biosynthesis accords with that illustrated in (195).²¹¹ Moreover, rifamycin W (196) was found to be converted by a rifamycin B-producing strain of *N. mediterranei* into rifamycin B [as (193), with oxygen-substituted hydroquinone ring B], and it may be therefore that rifamycin W is an important intermediate in the biosynthesis of rifamycins.

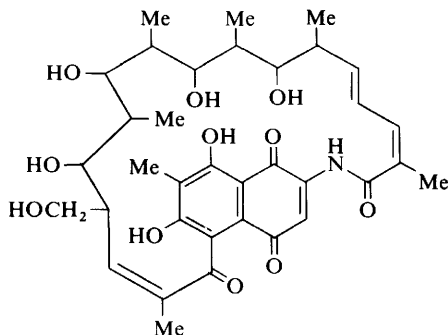

(196)

Penicillin.—Recent investigation of the biosynthesis of penicillins, *e.g.* penicillin V (198), have concentrated on the stereochemistry associated with the ring closure of a probable L-cysteinyl-L-valine intermediate as it affects the valine-derived part of the molecule.^{212–214} In support of the earlier work, incorporation of the label from (2*RS*, 3*S*)-[4-¹³C]valine (197) into the α -methyl group of penicillin V (198) has been reported,²¹⁵ *i.e.* incorporation is with retention of configuration at C-3 of valine. This defines the stereochemistry associated with, for example, the addition to the double bond of the hypothetical intermediate (200).

Attention has been turned to the cysteine-derived part of the penicillins.^{216,217} The results closely define (a) the fates of the hydrogen atoms present at C-2 and C-3 of cysteine (201) and (b) the overall stereochemistry involved in the incorporation of the amino-acid. L-[U-¹⁴C, 2-³H]Cystine was found²¹⁶ to give penicillin G (199) with only slight loss of tritium. The tritium label was shown (in an experiment with singly labelled precursor) to be located exclusively at C-6, similar results being obtained with L-[2-²H]cystine. These results, which confirm those obtained earlier,²¹⁸

²¹¹ R. J. White, E. Martinelli, and G. Lancini, *Proc. Nat. Acad. Sci. U.S.A.*, 1974, **71**, 3260.

²¹² H. Kluender, C. H. Bradley, C. J. Sih, P. Fawcett, and E. P. Abraham, *J. Amer. Chem. Soc.*, 1973, **95**, 6149.

²¹³ H. Kluender, F.-C. Huang, A. Fritzberg, H. Schnoes, C. J. Sih, P. Fawcett, and E. P. Abraham, *J. Amer. Chem. Soc.*, 1974, **96**, 4054; D. J. Aberhart, J. Y.-R. Chu, N. Neuss, C. H. Nash, J. Ocolowitz, L. L. Huckstep, and N. De La Higuera, *J.C.S. Chem. Comm.*, 1974, 564.

²¹⁴ R. B. Herbert, in ref. 5, p. 51.

²¹⁵ D. J. Aberhart and L. J. Lin, *J.C.S. Perkin I*, 1974, 2320.

²¹⁶ B. W. Bycroft, C. M. Wels, K. Corbett, and D. A. Lowe, *J.C.S. Chem. Comm.*, 1975, 123.

²¹⁷ D. J. Morecombe and D. W. Young, *J.C.S. Chem. Comm.*, 1975, 198.

²¹⁸ H. R. V. Arnstein and J. C. Crawhall, *Biochem. J.*, 1957, **67**, 180.

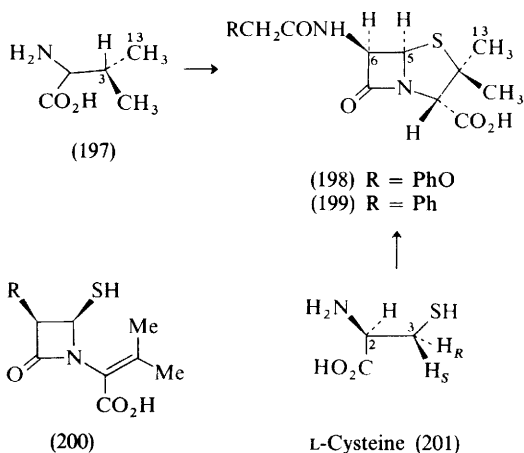

establish that incorporation of cystine into penicillin occurs without loss of the C-2 proton, and so hypothetical 2,3-dehydro-intermediates²¹⁶ are not implicated in penicillin biosynthesis.

Carbon atom 5 of the penicillins [as (198)] has been shown to derive from C-3 of cyst(e)ine [as (201)].²¹⁸ In feeding experiments with (2*R*, 3*R*)-[2,3-³H₂]cysteine, (2*R*, 3*S*)-[3-³H]cysteine, and [3,3'-³H₂]cysteine the fates of the hydrogen atoms originally present at C-3 of cysteine have been examined.²¹⁷ As expected tritium label was to some extent lost from C-2 of cysteine. More importantly, retention of nearly one half of the tritium from [3,3'-³H₂]cysteine indicated that hydrogen loss from C-3 was stereospecific. Further, high retention of tritium at C-5 of the penicillin G (199) derived from (2*R*, 3*R*)-[2,3-³H₂]cysteine and low retention in the experiment with (2*R*, 3*S*)-[3-³H]cysteine demonstrates that it is the 3-*pro-S* hydrogen of cysteine which is lost in penicillin biosynthesis, and overall the transformation occurs with retention of configuration, as it does for valine.

Prodigiosins.—The tripyrrole skeleton found in prodigiosin (202), produced by *Serratia marcescens*, is also found in (203) and (204), produced by *Streptomyces longisporus ruber*. As a result of feeding experiments with ¹³C-labelled precursors a unique pathway to (202) was revealed, for which the building blocks are acetate, alanine, serine, and proline.²¹⁹ Similar experiments²²⁰ in *S. longisporus ruber* have indicated clearly that the pathway used for the elaboration of (203) and (204) *in vivo* is closely related to that which affords (202).

Rings A and B of the three tripyrroles share a common origin in proline, acetate, and serine (Scheme 23), but ring C, where the structural differences lie, has appropriately different origins. Ring C of prodigiosin (202), with its alkyl side chains, is formed from acetate and alanine (Scheme 24).²¹⁹ In the case of (203) and (204)²²⁰ ring C and its substituents are formed from acetate again but glycine is used instead of alanine as the other unit; the units are also used differently in the construction of the

²¹⁹ R. J. Cushley, D. R. Anderson, S. R. Lipsky, R. J. Sykes, and H. H. Wasserman, *J. Amer. Chem. Soc.*, 1971, **93**, 6284; H. H. Wasserman, R. J. Sykes, P. Peverada, C. K. Shaw, R. J. Cushley, and S. R. Lipsky, *ibid.*, 1973, **95**, 6874; R. B. Herbert, in ref. 5, p. 47.

²²⁰ H. H. Wasserman, C. K. Shaw, and R. J. Sykes, *Tetrahedron Letters*, 1974, 2787.

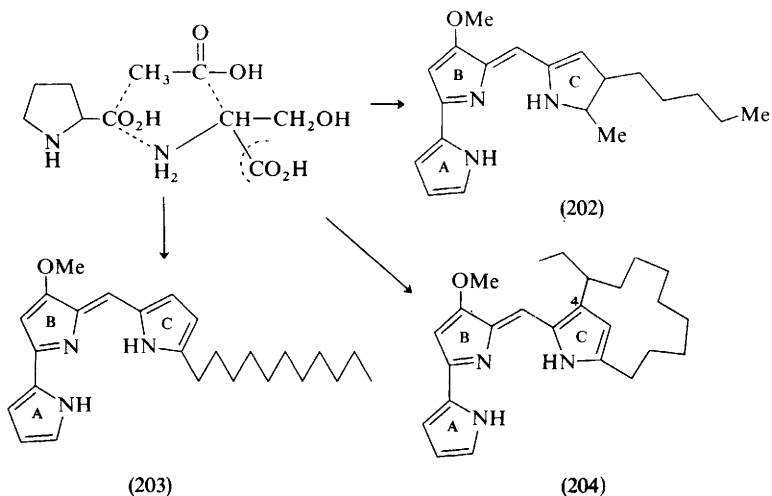

Scheme 23

different pyrrolic moieties (Scheme 24). It is further apparent that the side chain seen in (203) undergoes cyclization on to C-4 at some point in the biosynthesis of (204).

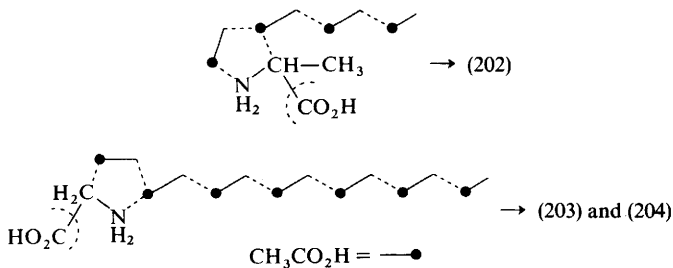

Scheme 24

The final step in the formation of prodigiosin involves condensation of (205) with (206).²²¹ It seems probable, considering the common origins of rings A and B of (202), (203), and (204), that the same aldehyde precursor (205) condenses *in vivo* with the appropriate pyrroles to give (202) and (203).



²²¹ H. H. Wasserman, J. E. McKeon, and U. V. Santer, *Biochem. Biophys. Res. Comm.*, 1960, 3, 146.

It has been observed that carbon from amino-acids capable of initiating biosynthesis of prodigiosin (202) in non-proliferating cells of *S. marascens* is incorporated into (202).²²² Some other amino-acids unable to act in this way were also incorporated after biosynthesis was initiated.

Steroid Alkaloids.—Further study on the biosynthesis of *Veratrum* alkaloids has been published²²³ (for earlier work see refs. 224 and 225). The results obtained with dormant rhizome slices of *V. grandiflorum* were that (a) labelled verazine (207) gave rise to radioactive rubijervine (211) and hakurirodine (210), a new alkaloid isolated from dormant tuber slices, and (b) labelled etioline (208), a probable progenitor of solanidine (209),²²⁶ was not incorporated into either alkaloid. It was concluded that the biosynthetic pathway to solanidine (209) branches from that to rubijervine (211) at verazine (207) (see Scheme 25).

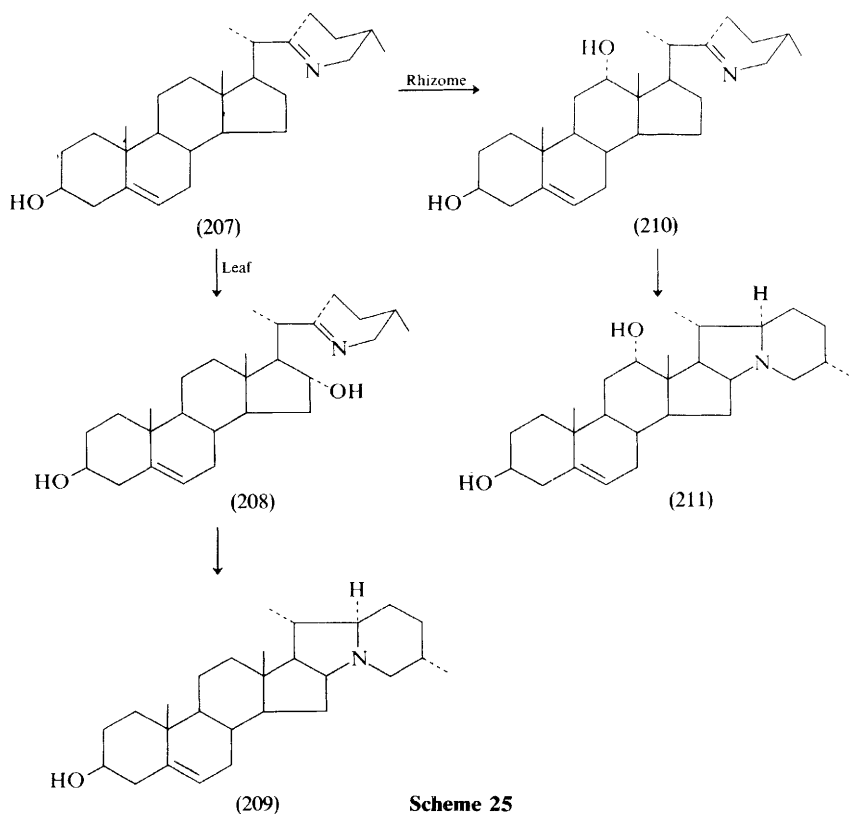

Scheme 25

²²² S. M. H. Qadri and R. P. Williams, *Canad. J. Microbiol.*, 1974, **20**, 461.

²²³ K. Kaneko, H. Seto, C. Motoki, and H. Mitsuhashi, *Phytochemistry*, 1975, **14**, 1295.

²²⁴ R. B. Herbert, in ref. 3, p. 42.

²²⁵ R. B. Herbert, in ref. 4, p. 37.

²²⁶ K. Kaneko, M. Watanabe, Y. Kawakoshi, and H. Mitsuhashi, *Tetrahedron Letters*, 1971, 4251; R. B. Herbert, in ref. 3, p. 293.

The inability of the plants to synthesize (210) and (211) after dormancy was indicated from the failure of acetate and verazine (207) [and etioline (208)] to serve as precursors for these alkaloids during budding. On the other hand [1-¹⁴C]acetate was incorporated into solanidine (209), verazine (207), and etioline (208) and it seems that alkaloid synthesis is transferred from the rhizome to the aerial parts during this growth phase. The suggested pathway²²³ is illustrated in part in Scheme 25.

Modification of the steroidal side chain which leads to steroidal alkaloids like tomatidine (212) and solasodine (213) is generally accepted as involving the sequence (214) → (215) → (212) or (213).²²⁷ As the C-27 methyl group of solasodine (213), a (25*R*)-alkaloid, derives from C-2 of mevalonate²²⁸ it follows that saturation of the Δ²⁴-intermediate (214), with geometry shown,²²⁹ occurs by addition of hydrogen to the 24-*si*,25-*si* face (Scheme 26; path *a*). (For an explanation of *si* and *re* terminology see ref. 230.) It has recently been shown that C-26 of tomatidine (212) derives from [2-¹⁴C]mevalonic acid, and so saturation of (214) must again occur from the 24-*si*,25-*si* face (Scheme 26; path *b*) to generate this (25*S*-alkaloid.²³¹

Incorporation of [¹⁴C]mevalonic acid into tomatine, in various parts of cultured tomato roots, has been recorded.²³² The results are consistent with an earlier conclusion that tomatine synthesis is associated with growth.^{225,233}

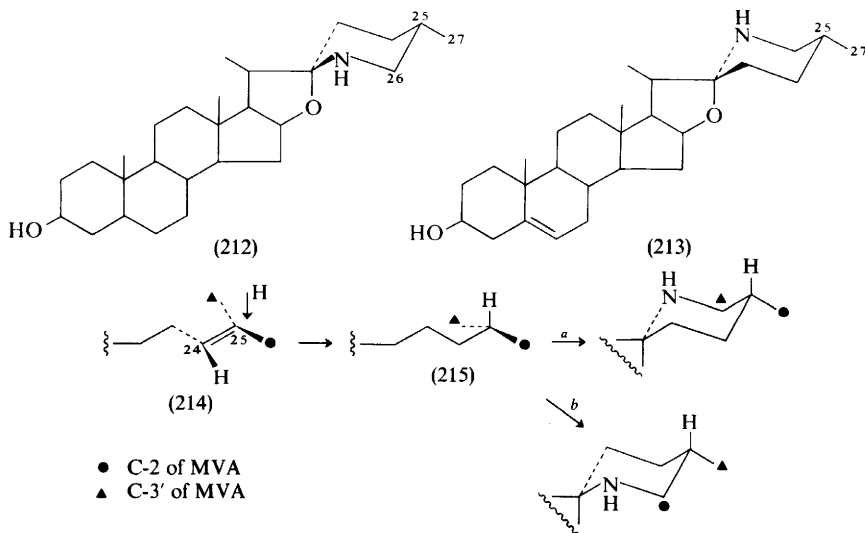

Scheme 26

²²⁷ K. Schreiber, in 'The Alkaloids', ed. R. H. F. Manske, Academic Press, New York, 1968, Vol. 10, p. 115; H. Ripperger, W. Moritz, and K. Schreiber, *Phytochemistry*, 1971, **10**, 2699; E. Heftmann, E. R. Lieber, and R. D. Bennett, *Phytochemistry*, 1967, **6**, 225; R. Tschesche and H. Hulpke, *Z. Naturforsch.*, 1966, **21b**, 893.

²²⁸ A. R. Guseva and V. A. Paseshnichenko, *Biochemistry (U.S.S.R.)*, 1962, **27**, 721.

²²⁹ K. J. Stone, W. R. Roeske, R. B. Clayton, and E. E. van Tamelen, *Chem. Comm.*, 1969, 530.

²³⁰ K. R. Hanson, *J. Amer. Chem. Soc.*, 1966, **88**, 2731.

²³¹ F. Ronchetti and G. Russo, *J.C.S. Chem. Comm.*, 1974, 785.

²³² J. G. Roddick, *Phytochemistry*, 1974, **13**, 1459.

²³³ J. G. Roddick, *Phytochemistry*, 1972, **11**, 2991.

2

Pyrrolidine, Piperidine, and Pyridine Alkaloids

BY A. R. PINDER

1 Pyrrolidine Alkaloids

A betaine alkaloid isolated from *Cadaba fruticosa* and named cadabine was found to be identical with stachydrine (1). Its ^{13}C n.m.r. spectrum has been analysed and signals assigned.¹ Work on the isolation and structure of alkaloids from *Streptomyces* spp. continues: a new tertiary base has been found in *Streptomyces* strain NA-337. It polymerized promptly at room temperature, but careful handling enabled it to be investigated by spectroscopic and chemical methods, which pointed to the structure (2) ($\lambda_{\text{max}}^{\text{MeOH}}$ 267 and 307 nm, ϵ 84 700 and 55 200, respectively); its ^1H and ^{13}C n.m.r. spectra have been analysed. Borohydride reduction yielded a dihydro-base, indicating that the alkaloid contained a tertiary imino nitrogen atom. Hofmann degradation of the dihydro-base afforded (3).²

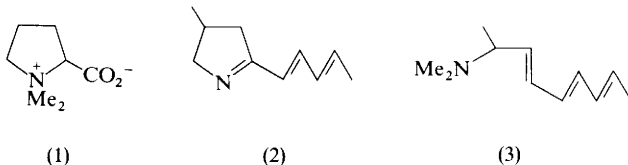

Polyzonimine, $\text{C}_{10}\text{H}_{17}\text{N}$, occurs in the defence secretion of the millipede *Polyzoniium rosalbum*. It is a liquid, monoterpene, tertiary base containing an imino nitrogen atom, revealed by spectroscopy [$\nu(\text{C}=\text{N})$ 1626 cm^{-1}]. An X-ray diffraction analysis of a perchloric acid derivative revealed structure (4) for the alkaloid, confirmation being provided by synthesis (Scheme 1).³ Tests on the compound demonstrated its irritancy towards various insects.³

The phthalide alkaloid shihunine (5), isolated earlier from *Dendrobium lohonense*, has been synthesized (Scheme 2).⁴

***Dendrobium* Alkaloids.**—A possible synthetic route to the alkaloid dendrobine (6; R = H) has been explored. The key reaction in the sequence was the intramolecular

¹ V. U. Ahaman, A. Basha, and A.-u.-Rahman, *Phytochemistry*, 1975, **14**, 292.

² M. Onda, Y. Konda, Y. Narimatsu, H. Tanaka, J. Awaya, and S. Omura, *Chem. and Pharm. Bull. (Japan)*, 1974, **22**, 2916.

³ J. Smolanoff, A. F. Kluge, J. Meinwald, A. McPhail, R. W. Miller, K. Hicks, and T. Eisner, *Science*, 1975, **188**, 734.

⁴ E. Breuer and S. Zbaida, *Tetrahedron*, 1975, **31**, 499.

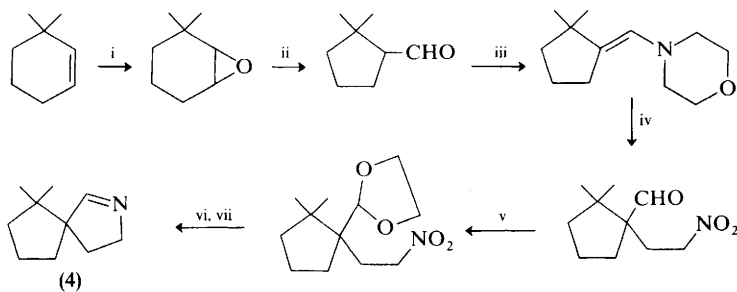

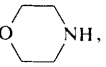
Reagents: i, $m\text{-ClC}_6\text{H}_4\text{CO}_3\text{H}$; ii, LiBr, HMPA; iii, , H^+ ; iv, $\text{AcOCH}_2\text{CH}_2\text{NO}_2$, MeCN; v, $(\text{CH}_2\text{OH})_2$, H^+ ; vi, H_2 , Ni; vii, H^+

Scheme 1

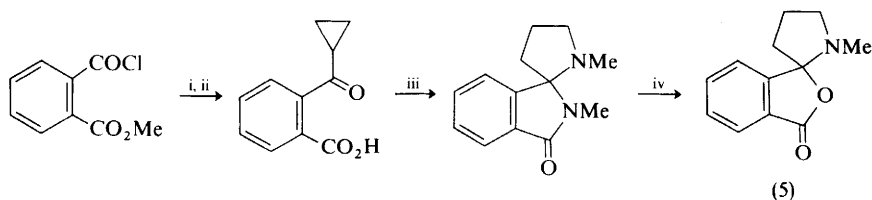

Reagents: i, $\text{Cd}(\text{C}_3\text{H}_5)_2$; ii, KOH; iii, MeNH_2 , $180\text{--}190^\circ\text{C}$; iv, 48% HBr

Scheme 2

stereospecific Michael addition – cyclization of the unsaturated nitrile (7), which led only to the stereoisomer (8).⁵ Biosynthetic investigations on the alkaloid have revealed that 2-*trans*,6-*trans*-farnesol is a precursor of the compound *in vivo*, rather

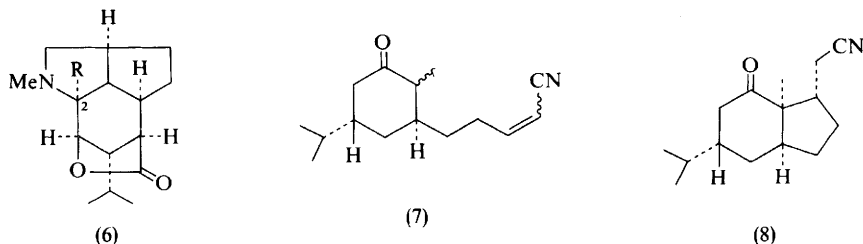

than the 2-*cis*,6-*trans*-isomer. The 1-*pro-R* hydrogen atom of farnesol suffers a 1,3-shift in the early stages, as outlined in Scheme 3.⁶

Synthesis of 2-hydroxydendrobine (6; $\text{R}=\text{OH}$) and nobiline (9) have been described. The starting point was the keto-lactam (10; $\text{R}=\text{H}$) already encountered

⁵ D. N. Brattesani and C. H. Heathcock, *J. Org. Chem.*, 1975, **40**, 2165.

⁶ A. Corbella, P. Gariboldi, G. Jommi, and M. Sisti, *J.C.S. Chem. Comm.*, 1975, 288.

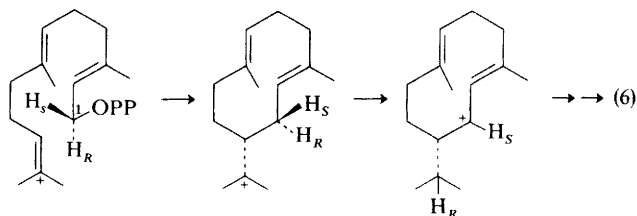

Scheme 3

as a degradation product of dendrobine. This was brominated and then treated with water, to yield the hydroxylactam (10; R = OH), which was reduced with zinc borohydride and then treated with sodium hydride to give lactone (11). Treatment of the latter with triethyloxonium tetrafluoroborate, followed by borohydride reduction and hydrolysis, gave 2-hydroxydendrobine (6; R = OH); reaction of this base with formaldehyde and formic acid gave nobiline (9).⁷

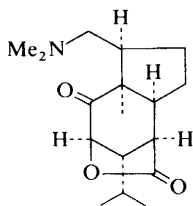

(9)

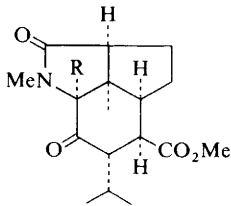

(10)

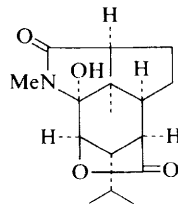

(11)

2 Piperidine Alkaloids

Stenusine is a water-spreading alkaloid which occurs in the pygidial defence gland of the staphylinid *Stenus comma*, and is used by the animal to enable it to move rapidly over a water surface. Its structure, *N*-ethyl-3-(2-methylbutyl)piperidine (12) has been elucidated largely by mass spectrometry because of paucity of material, key fragment peaks being found at *m/e* 30, 44, 58, 72, and 113, the last being unusual because it is of odd mass number. It arises from (12) by loss of a pentenyl group from position 3 followed by hydrogen shift. Structure (12) has been confirmed by total synthesis, although details are lacking; the absolute configuration of the optically active base is being investigated.⁸

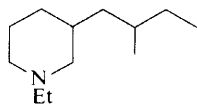

(12)

(-)-Pinidine (14) has been synthesized from 2,6-lutidine as summarized in Scheme 4. The intermediate alcohol (13) was obtained as a mixture of two

⁷ M. Suzuki, K. Yamada, and Y. Hirata, *Chem. Letters*, 1975, 611.

⁸ H. Schildknecht, D. Krauss, J. Connert, H. Essenbreis, and N. Orfanides, *Angew. Chem. Internat. Edn.*, 1975, **14**, 427.

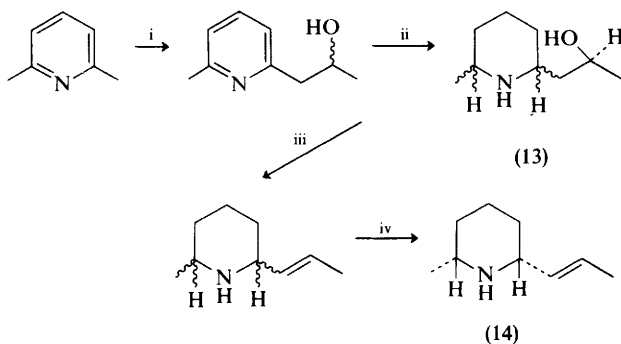

Reagents: i, MeCHO, BuLi; ii, 3H₂, Pt, HCl; iii, KHSO₄, 170 °C; iv, (+)- and (-)-6,6'-dinitrodiphenic acid

Scheme 4

racemates, step ii being known from precedent to lead stereospecifically to a *cis*-2,6-dialkylpiperidine. The alcohols could not be separated, so were dehydrated as a mixture to racemic pinidine which was resolved.⁹ Tracer studies have shown that 5,9-dioxodecanoic acid is not a precursor of the alkaloid in *Pinus jeffreyi* plants.⁹

Two new alkaloids have been isolated from leaves of *Bathiorhamnus cryptophorus*. The major one, cryptophorine, has been examined in detail spectroscopically. It absorbed four moles of hydrogen on catalytic reduction yielding a saturated base, and contained an *N*-methyl group, a secondary alcohol group, and four conjugated double bonds ($\lambda_{\max}^{\text{EtOH}}$ 278, 289, 302, and 316 nm). Dehydrogenation yielded a 3-hydroxypyridine, C₁₆H₂₇NO, which on n.m.r. spectral evidence was 2,3,6-trisubstituted (no signals *ca.* 8.5 p.p.m. due to protons at positions 2 and 6), and which may consequently be formulated either as (15) or (16). The effect of a shift reagent on the n.m.r. spectrum of cryptophorine established that a —CH(Me)CH(OH)— group was present, and the side-chain was clearly seen to terminate in an ethyl group. These observations pointed to structure (17) for the alkaloid, the all-*cis* relative ring stereochemistry depicted also being deduced from n.m.r. analysis. The minor base, cryptophorinine, C₁₇H₂₉NO₂, is a dissecondary alcohol containing one fewer double bond. On mass and n.m.r. spectral evidence it is

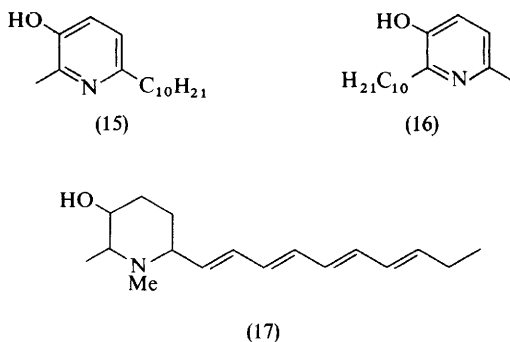

⁹ E. Leete and R. A. Carver, *J. Org. Chem.*, 1975, **40**, 2151.

formulated as (18), the hydroxy-group being placed in the side-chain as shown because of a fragment peak at m/e 210 (19) in the mass spectrum. An easy dehydration to cryptophorine would have been anticipated, but has not been reported.^{10,11}

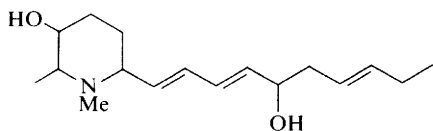

(18)

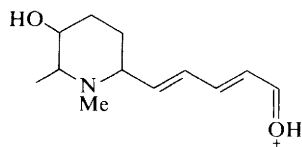

(19)

A second alkaloid from *Streptomyces* sp. NA-337, $C_{10}H_{11}NO$, proved to be a tertiary base (not *N*-methyl), reducible by borohydride to a secondary amine and therefore containing a $C=N$ group. N.m.r. spectral study revealed an ethylidene group (δ 2.18d and 6.32q, $J = 8$ Hz) and a *cis* ethylenic linkage (δ 6.94d and 8.44d, $J = 6$ Hz). The oxygen atom was suspected of being ethereal since the i.r. spectrum showed neither OH nor $C=O$ bands. Structure (20), which was proposed on spectral and chemical evidence, is the same as that advanced earlier for a base isolated from *Streptomyces abikoensis* and called abikoviromycin. The identity of the two was settled beyond doubt by a direct comparison between the methiodide of the *N*-methyl-dihydro-base and 4,4a-epoxy-5-(*E*)-ethylidene-1-methyl-2,3,4,4a,5,7a-hexahydro-1H-1-pyridine methiodide (21), derived from abikoviromycin.²

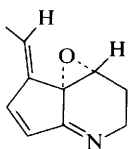

(20)

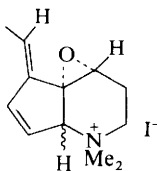

(21)

Spiropiperidine Alkaloids.—Several new minor bases have been isolated from the skin of the arrow poison frog *Dendrobates histrionicus*, of Colombian origin. They are related structurally to histrionicotoxin (22) and dihydrohistrionicotoxin (23), differing from these bases in the nature of the 2- C_5 and 7- C_4 side-chains. Careful n.m.r. and mass spectral analysis, coupled with hydrogenation studies on histrionicotoxin, have enabled structures to be advanced for the bases. The alkaloids are of value in studies of ion conductance in electrogenic membranes; the nature of the side-chain is important in connexion with cholinolytic activity or antagonism to the transport of sodium and potassium ions through such membranes.¹² Stereocontrolled syntheses of (\pm)-perhydrohistrionicotoxin (24) have been described,^{13–15} as

¹⁰ J. Bruneton, A. Cavé, and R. R. Paris, *Plant. Med. Phytother.*, 1975, **9**, 21 (*Chem. Abs.*, 1975, **83**, 28399z).

¹¹ J. Bruneton and A. Cavé, *Tetrahedron Letters*, 1975, 739.

¹² T. Tokuyama, K. Uenoyama, G. Brown, J. W. Daly, and B. Witkop, *Helv. Chim. Acta*, 1974, **57**, 2597.

¹³ M. Aratani, L. V. Dunkerton, T. Fukuyama, Y. Kishi, H. Kakoi, S. Sugiura, and S. Inoue, *J. Org. Chem.*, 1975, **40**, 2009.

¹⁴ T. Fukuyama, L. V. Dunkerton, M. Aratani, and Y. Kishi, *J. Org. Chem.*, 1975, **40**, 2012.

¹⁵ E. J. Corey, J. F. Arnett, and G. N. Widiger, *J. Amer. Chem. Soc.*, 1975, **97**, 430.

well as one of (\pm)-octahydrohistrionicotoxin (25),¹⁴ of natural occurrence,¹³ and a synthetic approach to histrionicotoxin and dihydrohistrionicotoxin (23) involving an intramolecular cyclization of a nitron with an activated olefin has been outlined.¹⁶

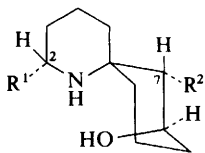

- (22) $R^1 = \text{CH}_2\text{CH}^{\text{cis}}\text{CHC}\equiv\text{CH}$; $R^2 = \text{CH}^{\text{cis}}\text{CHC}\equiv\text{CH}$
 (23) $R^1 = \text{CH}_2\text{CH}_2\text{CH}=\text{C}=\text{CH}_2$; $R^2 = \text{CH}^{\text{cis}}\text{CHC}\equiv\text{CH}$
 (24) $R^1 = n\text{-C}_5\text{H}_{11}$; $R^2 = n\text{-C}_4\text{H}_9$
 (25) $R^1 = \text{CH}_2\text{CH}_2\text{CH}_2\text{CH}=\text{CH}_2$; $R^2 = \text{CH}_2\text{CH}_2\text{CH}=\text{CH}_2$

Decahydroquinoline Alkaloids.—The structure of pumiliotoxin-C (26) has been confirmed by an X-ray diffraction analysis of its hydrochloride,¹⁷ and by two total syntheses of the racemic base.^{17,18} The syntheses are outlined in Schemes 5¹⁷ and 6.¹⁸

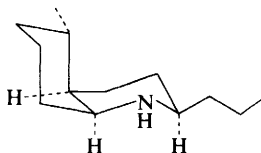

(26)

Bispiperidine Alkaloids.—The mass spectrometric behaviour of bispiperidyl bases of the ammodendrine (27) type has been investigated. They display, along with their acyl analogues, prominent peaks due to amide bond cleavage, and to several rearrangement ions. An unusual feature is fragmentation involving loss of a hydroxy-group, unprecedented amongst amides. *N*-Acetylammodendrine suffers a very easy elimination of water leading to a base peak at $M-17$ even at low accelerating potential.¹⁹ Three new alkaloids of this family have been isolated from *Lupinus formosus* Greene. They are (+)-*N'*-methylammodendrine (28), *N*-acetylhystrine (29), and smipine (30). The first two were formulated on the basis of mass spectral study, and the structures were confirmed by direct comparison with products synthesized from ammodendrine (27) and hystrine (31), respectively, by obvious reactions. Smipine (30) is a piperidine-pyrrolidine base whose mass spectrum contained a peak at m/e 112, which implied the loss of an unsaturated five-membered nitrogen ring $\text{C}_4\text{H}_6\text{N}$, and at 151 ($M-\text{CHO}$). After subtraction of these two moieties from M , a piperidyl ring remains. I.r. and n.m.r. spectral studies pointed to structure (30), the lack of optical activity in the base possibly being explicable in terms of a tautomeric equilibrium between (30) and the enediamine (32). Structure (30) was confirmed by synthesis from α -tripiperidine as depicted in Scheme 7. Smipine may arise biogenetically by oxidative rearrangement of one of the major bases co-occurring in the plant.²⁰

¹⁶ J. J. Tufariello and E. J. Trybulski, *J. Org. Chem.*, 1974, **39**, 3378.

¹⁷ T. Ibuka, Y. Inubushi, I. Saji, K. Tanaka, and N. Masaki, *Tetrahedron Letters*, 1975, 323.

¹⁸ W. Oppolzer, W. Fröstl, and H. P. Weber, *Helv. Chim. Acta*, 1975, **58**, 593.

¹⁹ W. L. Fitch and C. Djerassi, *J. Amer. Chem. Soc.*, 1974, **96**, 4917.

²⁰ W. L. Fitch, P. M. Dolinger, and C. Djerassi, *J. Org. Chem.*, 1974, **39**, 2974.

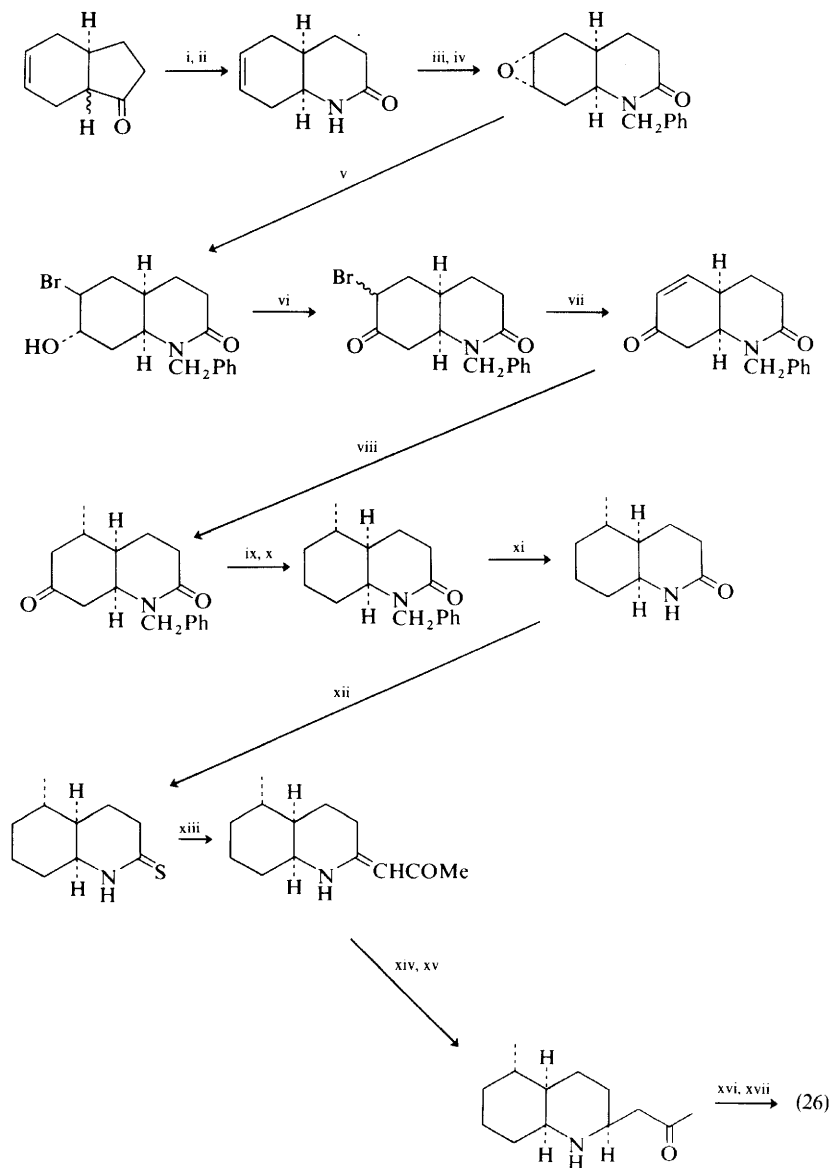

Reagents: i, NH_2OH ; ii, $p\text{-MeC}_6\text{H}_4\text{SO}_2\text{Cl}$; iii, benzylation; iv, $m\text{-ClC}_6\text{H}_4\text{CO}_2\text{H}$; v, HBr ; vi, CrO_3 ; vii, $\text{LiBr-Li}_2\text{CO}_3\text{-DMF}$; viii, LiCuMe_2 ; ix, $(\text{CH}_2\text{SH})_2, \text{H}^+$; W-2 Ni ; xi, reductive desaturation; xii, P_2S_5 ; xiii, BrCH_2COMe , then Ph_3P ; xiv, H_2, PtO_2 ; xv, CrO_3 ; xvi, $(\text{CH}_2\text{SH})_2, \text{H}^+$; xvii, W-2 Ni

Scheme 5

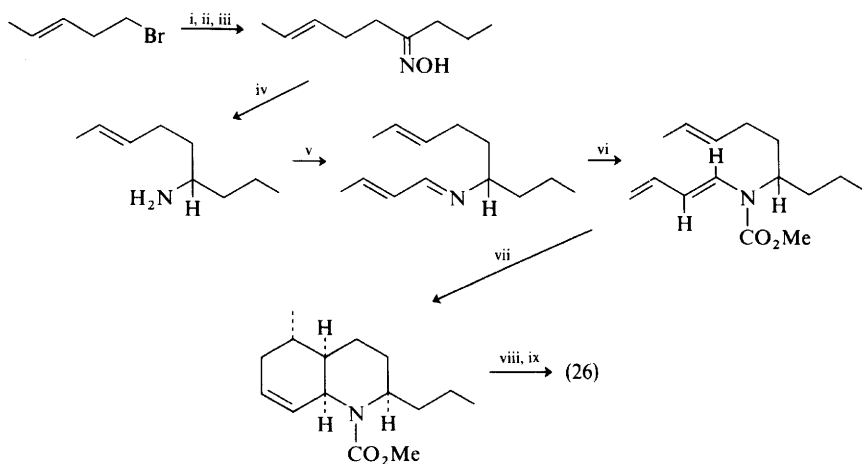

Scheme 6

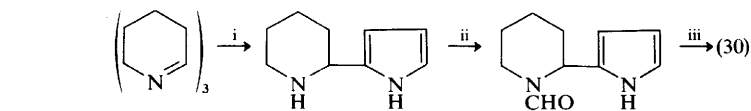
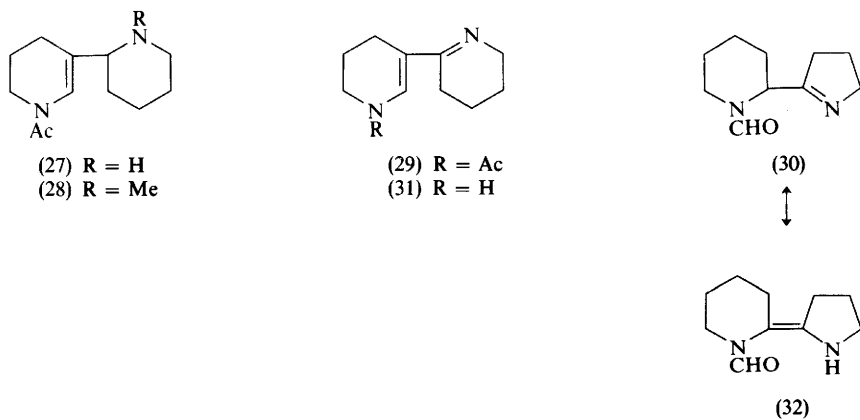

Reagents: i, $\text{C}_4\text{H}_7\text{NH}$, Δ ; ii, CCl_3CHO , 0°C ; iii, Zn, HCl, 0°C

Scheme 7

A new synthesis of (\pm)-carpamic acid (33) has been reported.²¹ A new synthesis of carpaine (34), utilizing a procedure developed recently for the synthesis of macrocyclic lactones,²² has been described briefly; the key reaction was between *N*-benzyloxycarbonylcarpamic acid (35), 2,2'-dipyridyl disulphide, and triphenylphosphine, affording *NN'*-bisbenzyloxycarbonylcarpaine in better than 50% yield.²³

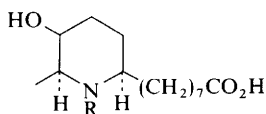

(33) R = H
(35) R = CO·O·CH₂Ph

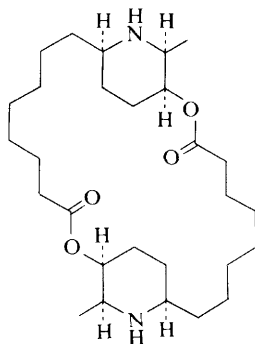

(34)

3 Pyridine Alkaloids

Nicotine has been found in *Anthocoris tasmanica* (Solanaceae).²⁴ Anibine (36) and a new alkaloid duckein are found in the trunk wood of *Aniba duckei* (Lauraceae). The latter is formulated as (37) on mass and n.m.r. spectral evidence.²⁵

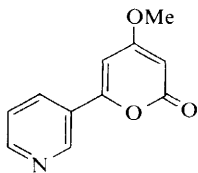

(36)

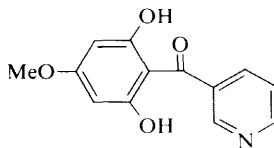

(37)

Two new alkaloids have been isolated from Burley tobacco (*Nicotiana tabacum* L.) condensate, and their structures elucidated mainly on mass and n.m.r. spectral evidence. Structure (38) has been assigned to one and confirmed by two syntheses, one of which involves the exhaustive acetylation of isophorone (39) with acetic anhydride-perchloric acid to the pyrylium salt (40). Ammonolysis of the salt yielded the alkaloid (38). The second alkaloid, formulated as (41), was synthesized from 5,5-dimethyl-2-cyclopenten-1-one (42) *via* Michael addition of ethyl acetoacetate to give, after hydrolysis and decarboxylation, (43). Regioselective acetalization then

²¹ E. Brown and A. Bourguin, *Tetrahedron*, 1975, **31**, 1047.

²² E. J. Corey and K. C. Nicolaou, *J. Amer. Chem. Soc.*, 1974, **96**, 5614; E. J. Corey, K. C. Nicolaou, and L. S. Melvin, *ibid.*, 1975, **97**, 653.

²³ E. J. Corey, K. C. Nicolaou, and L. S. Melvin, *J. Amer. Chem. Soc.*, 1975, **97**, 654.

²⁴ I. R. C. Bick, J. B. Bremner, J. W. Gillard, and K. N. Winzenburg, *Austral J. Chem.*, 1974, **27**, 2515.

²⁵ D. deB. Correa and O. R. Gottlieb, *Phytochemistry*, 1975, **14**, 271.

generated (44), which with ethyl formate afforded (45), hydrolysed to (46). Treatment with ammonium acetate gave a dihydropyridine, which on oxidation with nitrous acid gave (41).²⁶

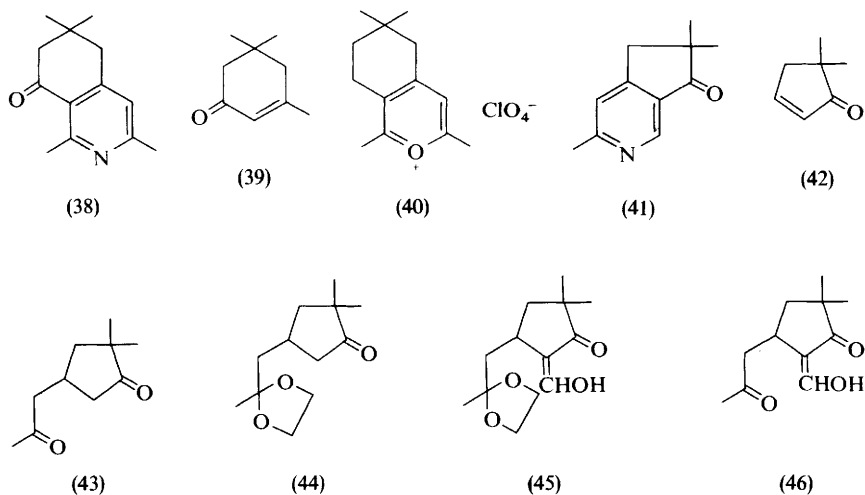

The alkaloid fabianine (47) has been synthesized from pulegone by the route shown in Scheme 8.²⁷

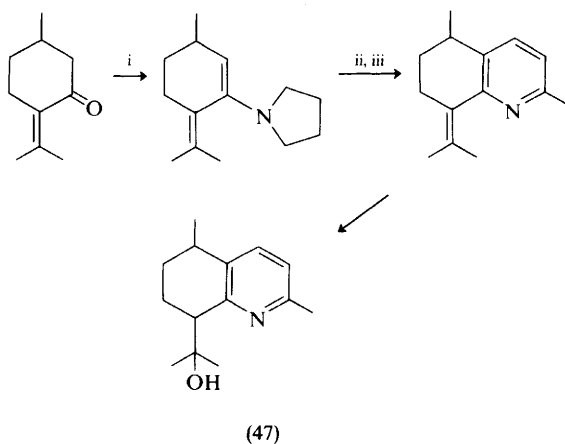

Reagents: i, pyrrolidine; ii, $\text{MeCOCH}=\text{CH}_2$; iii, NH_2OH ; iv, H^+ , H_2O

Scheme 8

²⁶ E. Demole and C. Demole, *Helv. Chim. Acta*, 1975, **58**, 523.

²⁷ P. Teisseire, B. Shimizu, M. Plattier, B. Corbier, and P. Rouillier, *Recherches*, 1974, **19**, 241 (*Chem. Abs.*, 1975, **83**, 28 395v).

Evonine has been synthesized starting with hydroxy-ester (48) by conversion into the mixed anhydride (49), followed by condensation with evoninol acetone pentamethyl ether (50). Several simple steps then led to evonine (51) (Scheme 9).²⁸

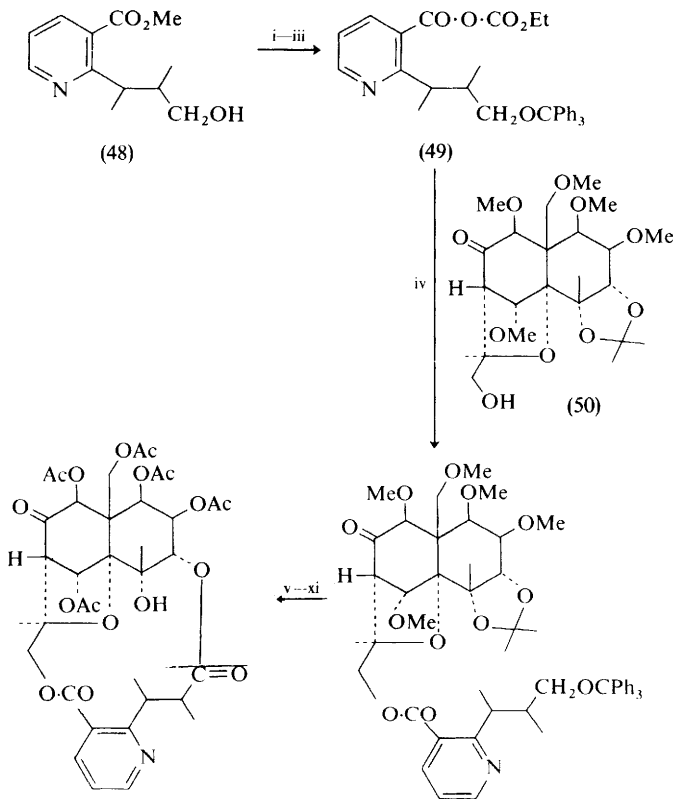

Reagents: i, Ph_3CCl , py; ii, ^-OH ; iii, ClCO_2Et , Et_3N ; iv, Me_2N -, Et_3N ; v, AcOH , 50°C ; vi, CrO_3 -py; vii, AcOH - H_2O , 85°C ; viii, CH_2N_2 ; ix, NaH ; x, BCl_3 , CH_2Cl_2 ; xi, Ac_2O -py

Scheme 9

1 Occurrence, and Structures of New Alkaloids

Tropine trimethoxycinnamate (1), an alkaloid¹ of the Queensland tree, *Erythroxylon ellipticum* R.Br., has now been isolated² from *E. monogynum* Roxb. of Indian origin, in addition to benzoyltropine, cinnamoylcocaine, and ecogonine.³

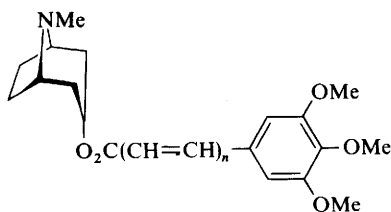
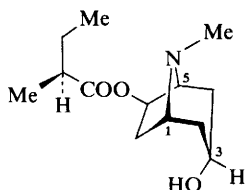
(1) $n = 1$ 

(2)

6 β -(2-Methylbutanoyloxy)tropane-3 α -ol (2), a new alkaloid, a major base out of four formerly unknown bases, has been isolated⁴ by partition column chromatography from *Datura ceratocaula*, the Mexican 'Torna loca' (Maddening plant). ¹H.N.m.r. studies revealed the characteristic features⁵ of C-3,C-6 disubstituted tropanes: the free hydroxy-group was at C-3 and α -oriented, and the 2-methylbutanoyl group was at C-6. The mass spectrum was typical of a disubstituted tropane,⁶ gave the base peak m/e 113, and the molecular formula of $C_{13}H_{23}NO_2$. Hydrolysis gave (-)3R : 6R-tropanediol⁷ and L(+)-2-methylbutanoic acid.⁸ The structure of (2) was confirmed by synthesis of its racemate from (\pm)-6 β -hydroxytropane-3-one and (\pm)-2-methylbutanoyl chloride, followed by reduction. It is of interest that the 6 β -propanoyl analogue,⁹ from *Datura innoxia* Miller, occurs as the 3 α -tigloyl derivative (3). 4-Methoxybenzoic acid has been detected for the first time as an acylating group, of tropane-3 α ,6 β -diol, in the new alkaloid physochlain

¹ S. R. Johns, J. A. Lamberton, and A. A. Sioumis, *Austral. J. Chem.*, 1970, **23**, 421.

² T. H. Agar, W. C. Evans, and P. G. Treagust, *J. Pharm. Pharmacol.*, 1974, **26**, Suppl., 111P.

³ R. N. Chopra and N. N. Gosh, *Arch. Pharm.*, 1938, **276**, 340.

⁴ P. J. Beresford and J. G. Woolley, *Phytochemistry*, 1974, **13**, 2511.

⁵ J. Parello, P. Longevialle, W. Vetter, and J. A. McCloskey, *Bull. Soc. chim. France*, 1963, 2787; G. Fodor, 'Tropane Alkaloids', in 'Chemistry of the Alkaloids', ed. S. W. Pelletier, van Nostrand Reinhold, New York, London, 1970, p. 431.

⁶ E. C. Blossy, H. Budzikiewicz, M. Ohashi, G. Fodor, and C. Djerassi, *Tetrahedron*, 1964, **20**, 585.

⁷ G. Fodor and F. Soti, *J. Chem. Soc.*, 1965, 6830.

⁸ G. Odham, *Arkiv Kemi*, 1963, **20**, 507.

⁹ P. J. Beresford and J. G. Woolley, *Phytochemistry*, 1974, **13**, 1249.

(4),¹⁰ from *Physochlaina alaica* Korot. Hyoscyine, hyoscyamine and 6 β -hydroxyhyoscyamine were found earlier¹¹ in the same plant. No synthesis was reported. However, the prediction by Phillipson¹² of the occurrence of tropane

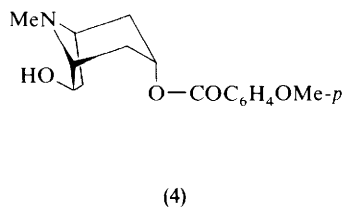
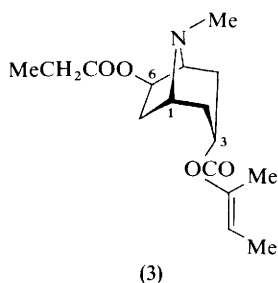

N-oxides in Nature has recently been confirmed by his own¹³ and two other teams.^{14,15} In addition to the *N*-oxides of hyoscyamine (5a) and hyoscyine (5b), the *N*-oxide (6) of 6-hydroxyhyoscyamine¹⁴ and the *N*-oxide (8)¹⁵ of the 3 α -epimer of tigloidine, i.e. 3 α -tigloyloxytropane (7)¹⁶ have been discovered.* Compounds (7) and (8) occur jointly in the roots of *Physalis alkekengi* L. var. *francheti* Hort. forma *bunyardii* Makino. Degradation with trifluoroacetic anhydride gave *N*-trifluoroacetylnortropane-3 α -yl tigloate and this, in turn, nortropine. Synthesis of (7) went routinely, by acylation with tiglic chloride of tropine, while (8) was obtained upon acylation of tropine *N*-oxide with the same acid chloride, surprisingly without concomitant Polonovski reaction of the *N*-oxide.

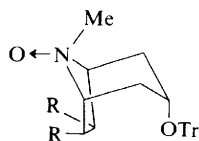

(5) a; R = H
b; R + R = O

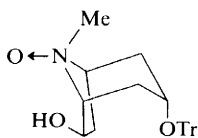

(6)

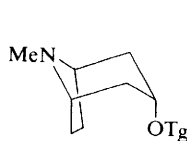

(7)

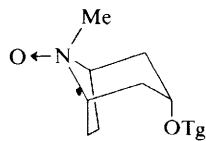

(8)

Tr = tropoyl

Tg = tigloyl

* *N*-configurations are assigned by analogy¹⁷ with (5a) and (5b). Tigloidine is 3 β -tigloyloxytropane, a known¹⁸ alkaloid.

¹⁰ R. T. Mirzamatov, K. L. Lutfullin, V. M. Malikov, and S. Yu. Yunusov, *Khim. prirod. Soedinenii*, 1974, **10**, 415.

¹¹ R. T. Mirzamatov, V. M. Malikov, K. L. Lutfullin, O. Khakimov, and S. Yu. Yunusov, *Khim. prirod. Soedinenii*, 1973, **9**, 566.

¹² J. D. Phillipson, *Xenobiotica*, 1971, **1**, 419.

¹³ J. D. Phillipson and S. S. Handa, *J. Pharm. Pharmacol.*, 1973, **25**, Suppl. 117P.

¹⁴ R. T. Mirzamatov, K. L. Lutfullin, V. M. Malikov, and S. Yu. Yunusov, *Khim. prirod. Soedinenii*, 1974, **10**, 540.

¹⁵ H. Yamaguchi, A. Numata, and K. Hokimoto, *Yakugaku Zasshi*, 1974, **94**, 1115.

¹⁶ G. Ghani, W. C. Evans, and V. A. Woolley, *Bangladesh Pharm. J.* 1972, **1**, 12 (*Chem. Abs.*, 1973, **79**, 75 871); no synthesis was reported.

¹⁷ C. Saunderson Huber, G. Fodor, and N. Mandava, *Canad. J. Chem.*, 1971, **20**, 3258.

¹⁸ G. Barger, W. F. Martin, and W. Mitchell, *J. Chem. Soc.*, 1937, 1820; G. Fodor, 'The Tropane Alkaloids', in 'The Alkaloids', ed. R. H. F. Manske, Academic Press, New York, London, 1960, Vol. 6, p. 146.

Sorption of moisture affects the stability of alkaloids¹⁹ in *A. belladonna* and *D. innoxia*: scopolamine proved much more stable than atropine. Isolation of 6 β -hydroxyhyoscyamine (9) and apohyoscyine from *Physochlaina alaica* has been described.²⁰ The relative configurations of four new *Knightia deplanchei* Vieill. ex Brongn. et Gris. alkaloids²¹ (10)—(12) have now been established²² by ¹³C n.m.r. A

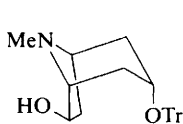

(9)

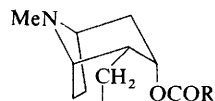
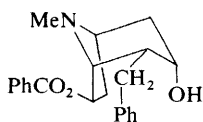
(10) a; R = Me
b; R = Ph

(11)

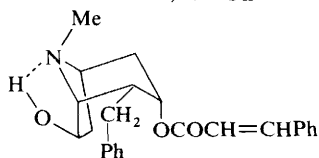

(12)

strong hydrogen-bond between 6 β (OH) and the ring nitrogen in (12) forces the *N*-methyl group to take the unusual²³ axial position.

2 Synthetic Chemical and Pharmacological Studies

A new route to tropane derivatives involving reaction of $\alpha\alpha\alpha'\alpha'$ -tetrabromoacetone with *N*-methoxycarbonylpyrrole and di-ironenecarbonyl was described in Volume 5. 6,7-Dehydronortropinone derivatives (13) can also be obtained in good yields from $\alpha\alpha'$ -dibromoketones and pyrroles (or *N*-methylpyrroles) with copper and sodium iodide.²⁴

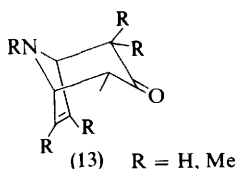

(13) R = H, Me

Optically active *N*-(α -phenethyl) derivatives of nortropinone (14) and norpseudopelletierine have been prepared for a c.d. study.²⁵ The octant rule can be applied to these tropanes since the carbonyl chromophore, although four σ -bonds away, is strongly enough perturbed to exhibit a $n \rightarrow \pi^*$ Cotton effect. Thus,

¹⁹ J. Lutomski and M. Turovska, *Herba Pol.*, 1973, **19**, 202 (*Chem. Abs.*, 1974, **81**, 41 326b).

²⁰ R. T. Mirzamatov, K. L. Lutfullin, V. M. Malikov, and S. Yu. Yunusov, *Khim. prirod. Soedinenii*, 1974, **10**, 416.

²¹ M. Lounasmaa and C.-J. Johansson, *Tetrahedron Letters*, 1974, 2509.

²² M. Lounasmaa, P. H. Wovkulich, and E. Wenkert, *J. Org. Chem.*, 1975, **40**, 3694.

²³ G. Fodor, R. V. Chastain, jun., D. Frehel, N. Mandava, M. J. Cooper, and (the late) E. L. Gooden, *J. Amer. Chem. Soc.*, 1971, **93**, 403.

²⁴ G. Fierz, R. Chidgey, and H. M. R. Hoffmann, *Angew. Chem. Internat. Edn.*, 1974, **13**, 410.

²⁵ Y. Kashman and S. Cherkez, *Tetrahedron*, 1972, **28**, 1211.

conformer populations as predicted by the octant rule were confirmed by c.d. and ^1H n.m.r. studies. *N*-Epimeric methiodides (15a and b) undergo easy equilibration, apparently^{23,26} via the tertiary Hofmann base. *N*-Stereochemistry of chiral tropanium salts can now be determined by c.d.

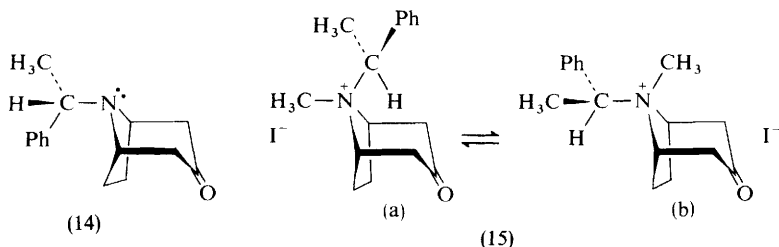

Selective hydrolysis of dihydrocinnamate protecting groups by chymotrypsin has been studied²⁷ with tropane-3 α ,6 β -diol diesters. The ester group at C-3 was cleaved by the enzyme, and alkaline hydrolysis selectively liberated the 6 β -hydroxy-group.²⁸ The suggested mechanism of the oxidation²⁹ of tropan-3 α -ol to tropinone, with benzoyl chloride, has now been established³⁰ as intramolecular hydride transfer. [3β - ^2H]Tropine was treated with benzoyl chloride and alkali; unlabelled tropinone and [^2H]benzaldehyde were isolated. The latter reacts, in turn, with tropinone to give methine-labelled 2,4-bis-benzylidene-tropan-3-one (17). The position of the label was ascertained by n.m.r. and mass spectroscopy. The transition state of the reaction is postulated to involve axial orientation (16) of the *N*-benzoyl group in the boat form of the ring, which shows that *N*-benzoyltropanium salts are reversibly formed, similar to quaternary *N*-cyano- and *N*-ethoxycarbonyl-tropanium salts³¹ but unlike *NN*-dialkyltropanium salts.²⁶ The major product of *N*-oxidation of tropine has been shown by n.m.r. spectroscopy and X-ray crystallography to have an equatorial oxygen atom.^{17,32}

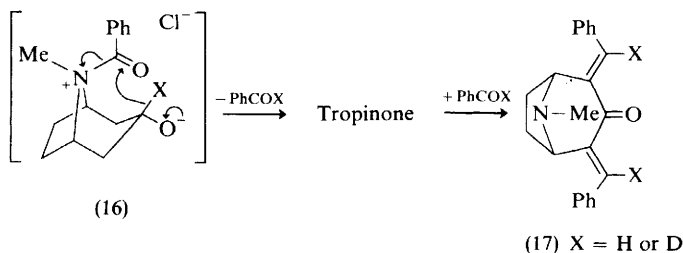

The kinetics of racemization of hyoscyamine to atropine in different alcohols have been studied.³³ Optimum yields were obtained in $\text{Me}_2\text{CHCH}_2\text{OH}$.

²⁶ U. O. De La Camp, A. T. Bottini, C. C. Thut, J. Gal, and A. G. Belletini, *J. Org. Chem.*, 1972, **37**, 324.

²⁷ Y. Y. Lin and J. B. Jones, *J. Org. Chem.*, 1973, **38**, 3575.

²⁸ G. Fodor, I. W. Vincze, and J. Tóth, *J. Chem. Soc.*, 1961, 3219.

²⁹ B. J. Calvert and J. D. Hobson, *J. Chem. Soc.*, 1965, 2723.

³⁰ P. J. Kocienski and M. Kirkup, personal communication to the Reporter.

³¹ G. Fodor, Sh. Abidi, and T. C. Carpenter, *J. Org. Chem.*, 1974, **39**, 1507.

³² G. Werner, M. Weichmann, P. Scheiber, A. Gieren, Th. Fischer, and W. Hoppe, *Annalen*, in the press.

³³ Yu. V. Shostenko, I. S. Simon, T. N. Gubina, and V. D. Shelkovi, *Zhur. fiz. Khim.*, 1974, **48**, 471.

Trifluoromethyl- and halogen-substituted tropic acid esters of tropine have been prepared³⁴ using DCC as a condensing agent. No enhanced atropine activity was achieved. The tropine ester of 3-indolylpropionic acid showed³⁵ less cholinolytic and spasmolytic activities than the diphenylacetic ester. On the other hand, the methohalide of 11-(tropanyloxy)dibenzo[*b,e*]thiepin, a tropanyl ether, showed broncho-spasmolytic activity;³⁶ *N*-2- β -hydroxyethylatropinium bromide is an anti-spasmodic.³⁷ A quaternary tropanium salt has been prepared³⁸ from 2-chloromethyl-1-methyl-2-benzimidazole. Reaction of norpsicaine and its propyl ester homologue with $\alpha\omega$ -dihalogenoalkanes³⁹ ($n = 2, 3, 6, 7, \text{ or } 8$) gave mostly the expected $\alpha\omega$ -bis-*N*-tropanylalkanes. With tetra- and penta-methylene bromides some azoniaspiro compounds (18) were formed. Both the norpsicaine and 'norpsicaine-neu' esters were expected to have novel pharmacodynamic properties. Addition of nortropans to mono- and bis-isocyanates and to reactive olefins, e.g. acrylonitrile, has been studied.⁴⁰ Neoplasm inhibiting scopolaminium salts⁴¹ of type (19) and others with parasympathetic blocking activity, without a side effect, type (20), have been prepared.⁴²

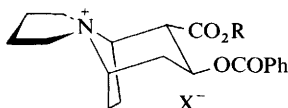
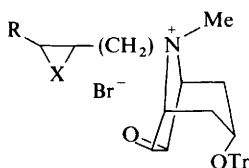
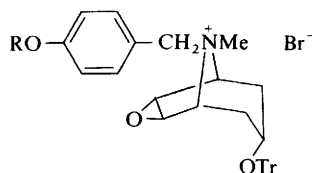
(18) R = Me or Prⁿ(19) R = H or Me
X = O, CH₂, or (CH₂)₂
Tr = tropanyl(20) R = Me or Buⁿ
Tr = tropanyl

Tropane-2-carboxylates (21) have been synthesized⁴³ by reaction of Grignard reagents with anhydroecgonine; (21a) was claimed to be 16 times as active as cocaine in the locomotor activity test while (21b) was 64 times as active. Compound (21a) retained only 10–20% of the anaesthetic activity of cocaine. The fluoro-derivative (21b) proved 5–20 times as active as cocaine in the reserpine-induced ptosis prevention and reversal tests, respectively.

³⁴ U. Amschler, *Arch. Pharm.*, 1973, **306**, 943.³⁵ N. N. Suvorov, M. D. Mashkovskii, V. N. Rusinova, K. A. Zaitseva, and O. V. Telenkova, *Khim. geterotsikl. Soedineniya*, 1975, 73.³⁶ F. Gadiant, Sandoz Ltd., Ger. Offen., 2 414 093 (*Chem. Abs.*, 1975, **82**, 103 152).³⁷ K. Kubota and S. Sugai, Jap. P., 73 00 900 (*Chem. Abs.*, 1974, **80**, 48 219).³⁸ E. A. Steck, *Org. Prep. Proced. Internat.*, 1975, **7**, 6.³⁹ G. Werner and K.-H. Störr, *Annalen*, 1974, 1639.⁴⁰ G. Werner and K.-H. Störr, *Annalen*, 1974, 1645.⁴¹ S. Casadio and A. Donetti, Ger. Offen., 2 316 728 (*Chem. Abs.*, 1974, **80**, 15 101).⁴² S. Tanaka, K. Hashimoto, and K. Higashi, Ger. Offen., 2 329 83 (*Chem. Abs.*, 1974, **80**, 83 364).⁴³ R. L. Clarke and S. J. Daum, Sterling Drug Inc., U.S.P. 3 813 404 (*Chem. Abs.*, 1974, **81**, 63 837).

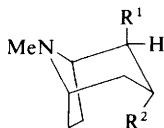

- (21) a; $R^1 = \text{CO}_2\text{Me}$, $R^2 = \text{Ph}$
 b; $R^1 = \text{CO}_2\text{Me}$, $R^2 = 4\text{-FC}_6\text{H}_4$

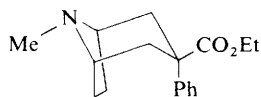

(22)

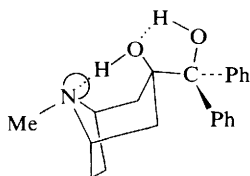

(23)

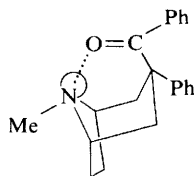

(24)

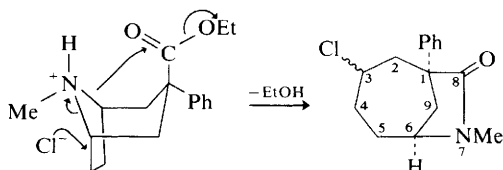

(25)

Conformational analysis⁴⁴ of 3 β -ethoxycarbonyl-3 α -phenyltropane, an analogue⁴⁵ of pethidine, by ¹H n.m.r. spectroscopy, indicated axial preference of the 3 α -phenyl group, hence a chair conformation for the piperidine ring (22). However, the intermediates 3 α -diphenylhydroxymethyl-3 β -tropanol (23) and 3 α -phenyl-3 β -tropanylphenyl ketone (24) favour the boat form. Pyrolysis⁴⁶ of (22) led, with the boat form in the transition state, to 7-aza-3-chloro-7-methyl-1-phenyl-8-oxobicyclo[4,2,1]nonane (25), based on elemental analysis and mass spectrum. (-)-1-*p*-Butoxyphenyl [α -³H]hyoscyminium bromide was prepared⁴⁷ from (-)-hyoscyamine and *p*-butoxy[α -³H]benzyl bromide. *N*-Methyl [1-³H]-'psicaine neu' and U-tritiated psicaine have also been described.⁴⁸

3 Analysis

Novel analytical methods have been developed. A recent book on alkaloid spectra⁴⁹ will certainly prove useful. Charge exchange mass spectroscopy⁵⁰ of morphine and tropane alkaloids using nitric oxide and nitrogen has led to a simplification of their mass spectra. In this technique the molecular ion that either was not observed or was of low abundance in classical mass spectra, becomes the base peak. Hence the

⁴⁴ A. F. Casy and J. E. Coates, *Org. Magn. Resonance*, 1974, **6**, 441.

⁴⁵ M. R. Bell and S. Archer, *J. Amer. Chem. Soc.*, 1960, **82**, 4638.

⁴⁶ J. E. Coates and A. F. Casy, *J. Org. Chem.*, 1974, **39**, 3044.

⁴⁷ T. Fujita, J. Tsutsumi, S. Tanaka, T. Hisamoto, and O. Shinzaburo, *J. Labelled Compounds*, 1973, **9**, 555.

⁴⁸ G. Werner and K.-H. Störr, *Annalen*, 1974, 1650.

⁴⁹ M. Kraft, 'Alkaloidspektren', Thieme, Stuttgart, 1975.

⁵⁰ I. Jardine and C. Fenselau, *Analyt. Chem.*, 1975, **47**, 730.

method can be applied to any tertiary amine which, when α -cleaved, will not immediately fragment.

Reviews^{51,52} on the chromatography of tropane alkaloids have appeared. High-pressure liquid chromatography was applied for the first time to separate⁵³ tropanes of closely related structure. Thin layer chromatography of ion pairs⁵⁴ has now been applied to tropane alkaloids.⁵⁵ Benzoylcgonine was detected in urine by gas chromatography,⁵⁶ as a cocaine metabolite. Colorimetric and other methods have been used in determining scopolamine and hyoscyamine contents in *A. belladonna* roots,⁵⁷ in prescription forms of drugs,^{58,59} and of cocaine in food.⁶⁰ A radioassay⁶¹ for atropine esterase activity in plant tissues has been outlined.

⁵¹ N. P. Maksyutina and E. O. Korzhavikh, *Farm. Zhur. (Kiev)*, 1974, **29**, 20 (*Chem. Abs.*, 1974, **81**, 96 480).

⁵² A. Mucharska, *Chromatogr. Cienkowsarstowa, Analit. Farm.*, 1973, 157 (*Chem. Abs.*, 1975, **82**, 103 196).

⁵³ M. H. Stutz and S. Sass, *Analyt. Chem.*, 1973, **45**, 2134.

⁵⁴ K. Groeningsson and G. Schill, *Acta Pharm. Suecica*, 1969, **6**, 447.

⁵⁵ I. Yankulov, *Rasteniavad Nauki (Bulg.)*, 1974, **11**, 59 (*Chem. Abs.*, 1974, **81**, 116 075).

⁵⁶ S. Koontz, D. Besemer, and R. Phillips, *J. Chromatography*, 1973, **85**, 75.

⁵⁷ O. Genius, *Dtsch. Apoth. Ztg.*, 1974, **114**, 1171.

⁵⁸ H. Ludwicki, A. Mucharska, and M. Sobiczewska, *Farm. Pol.*, 1974, **30**, 399.

⁵⁹ V. Das Gupta, *Amer. J. Hosp. Pharm.*, 1975, **32**, 215.

⁶⁰ V. Lovenberg, *J. Agric. Food Chem.*, 1974, **22**, 23.

⁶¹ M. Sugii, H. Muira, and H. Yamashita, *Radioisotopes*, 1974, **23**, 649.

4

The Pyrrolizidine Alkaloids*

BY D. H. G. CROUT

1 Introduction

Several useful reviews and compilations of data on pyrrolizidine alkaloids have been published. These include a review¹ of all aspects of pyrrolizidine alkaloid chemistry and biochemistry; this is comprehensive, but rather idiosyncratic in its balance (sixteen pages are devoted to the synthesis of necines and necic acids whereas physical and spectroscopic properties of the alkaloids are discussed in barely two.) Nevertheless, this up-to-date work will certainly be of great interest and usefulness to workers in the field. Klásek² has surveyed the investigations on pyrrolizidine alkaloids carried out at Olomouc, and Atal and Sawhney³ have produced a useful compilation of data on alkaloids from Indian *Crotalaria* species. Pyrrolizidine alkaloids from the Orchidaceae have been surveyed by Lüning⁴ and by Brandänge.⁵ Pyrrolizidine alkaloids are included in a comprehensive compilation of data on alkaloids isolated from plants occurring in the U.S.S.R.⁶

2 The Necine Bases

Atal, Culvenor, and their co-workers⁷ have completed their elucidation of the structure of croalbidine (1) (from *Crotalaria albida* Heyne ex Roth) by showing that the necine base, croalbinecine, is 1α -hydroxymethyl- 8α -pyrrolizidine- $2\beta,7\beta$ -diol. The configurations at C-1, C-7, and C-8 were determined by correlation with turneforcidine (2). This was achieved by conversion of croalbidine (1) into the chloro-derivative (3), on treatment with thionyl chloride, with simultaneous formation of a cyclic sulphite ester of the necic acid component. Catalytic hydrogenation gave the product (4) which was hydrolysed to trichodesmic acid and turneforcidine (2). Location of the additional hydroxy-group at C-2 was confirmed by appropriate n.m.r. decoupling experiments. Assignment of the β -configuration to the hydroxy-group at C-2 was strongly indicated by the magnitudes of the coupling constants $J_{1\beta,2}$

¹ A. Klásek and O. Weinbergová, in 'Recent Developments in the Chemistry of Natural Carbon Compounds', ed. R. Bognar, V. Bruckner, and Cs. Szántay, Akadémiai Kiadó, Budapest, 1975, Vol. VI, p. 37.

² A. Klásek, *Acta Univ. Palacki, Olomouc*, 1973, **65**, 33.

³ C. K. Atal and R. S. Sawhney, *Indian J. Pharm.*, 1973, **35**, 1.

⁴ B. Lüning, in 'The Orchids', ed. C. L. Withner, Wiley, New York, 1974, p. 349.

⁵ S. Brandänge, *Chem. Comm. Univ. Stockholm*, 1974, (3), 36 pp.

⁶ S. Yu. Yunusov, 'Alkaloids', Uzbek. Acad. Sci., 1974.

⁷ R. S. Sawhney, C. K. Atal, C. C. J. Culvenor, and L. W. Smith, *Austral. J. Chem.*, 1974, **27**, 1805.

* The numbering system used in this chapter follows the recommendations given in the paper by C. C. J. Culvenor, D. H. G. Crout, W. Klyne, W. P. Mose, J. D. Renwick, and P. M. Scopes, *J. Chem. Soc. (C)*, 1971, 3653.

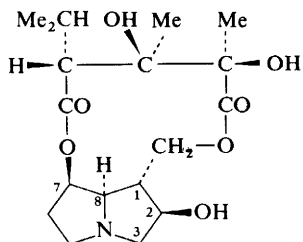

Croalbidine (1)

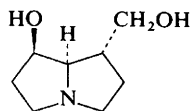

Turneformidine (2)

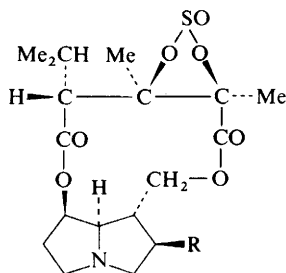

(3) R = Cl

(4) R = H

and $J_{2,3\beta}$ (both 8.0 Hz) which were attributed to *trans* hydrogens in a mainly diaxial conformation ($\theta \approx 160^\circ$) and the value of $J_{2,3\alpha}$ 5.8 Hz, consistent with *cis* hydrogens ($\theta \approx 30\text{--}40^\circ$). This assignment was supported by comparison with the analogous coupling constants in macronecine (1 β -hydroxymethyl-8 β -pyrrolizidine-2 β -ol), a model for the alternative 1 α -hydroxymethyl-8 β -pyrrolizidin-2 β -ol structure for croalbidine. These coupling constants: $J_{1\alpha,2}$ 5—6, $J_{2,3\alpha}$ 5—6, and $J_{2,3\beta}$ 1 Hz, are clearly different from the values obtained for croalbidine. The corresponding values for croalbidine (1): $J_{1\beta,2}$ 9.2, $J_{2,3\alpha}$ 6.5, and $J_{2,3\beta}$ 9.2 Hz, supported the configurational assignments already deduced. However, it would be desirable to confirm the assignment of the 2 β configuration to the C-2 hydroxy-group in croalbidine by X-ray crystallography. This would help in assessing the reliability of the method of configurational analysis by n.m.r.; it would also be of interest to determine the conformational consequences (e.g. in terms of non-coplanarity of the ester groups) of the unusual *trans* configuration of the 1-hydroxymethyl and 7-hydroxy-groups.

3 The Ester Alkaloids

The previously proposed⁸ structure (5) for swazine has been revised⁹ to (6) with reversal of the mode of attachment of the necic acid to the necine base, retronecine. The revised structure brings swazine (6) into line with the majority of cyclic diester

⁸ C. G. Gordon-Gray, R. B. Wells, N. Hallak, M. B. Hursthouse, S. Neidle, and T. B. Toube, *Tetrahedron Letters*, 1972, 707.

⁹ C. G. Gordon-Gray and R. B. Wells, *J.C.S. Perkin I*, 1974, 1556.

alkaloids in which the α -hydroxyacid terminus is esterified to the allylic hydroxy-group.¹⁰ This mode of attachment was demonstrated by hydrogenolysis of swazine (6) under mildly basic conditions to a zwitterionic product (7) which gave a positive test for an α -hydroxy-acid. Swazine (6) on acid hydrolysis gave a spirodilactone (8), the structure of which has been confirmed by X-ray crystallography.⁸ The 1,2,3-triol system in the dilactone (8) and the molecular formula of swazine suggested the presence of an exocyclic epoxide group at C-13 in the necic acid component. This deduction was supported by the observation of readily decoupled one-proton doublets at δ 2.77 and 2.31 (J 4 Hz) in the n.m.r. spectrum. Hydrolysis of swazine (6) with barium hydroxide gave retronecine and an α -hydroxy acid, isoswazinic acid (9), clearly formed by hydrolytic cleavage of the epoxide ring followed by Michael-type addition of the primary hydroxy-group thus generated to the exocyclic methylene group, and lactone formation between the tertiary hydroxy-group produced at C-13 and the C-16 carboxy-function. The absolute configuration of swazine was established by X-ray analysis of swazine methiodide¹¹ and of the spirodilactone (8).⁸ Swazine (6) does not give the u.v. spectrum expected from an $\alpha\beta$ -unsaturated ester [the maximum occurs at 195 nm (ϵ 11 000)], because the plane of the exocyclic double bond is at an angle of 45° to the plane of the ester group.

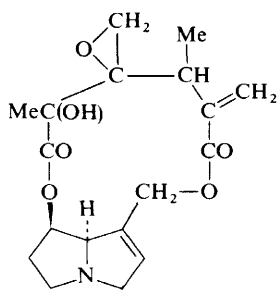

(5)

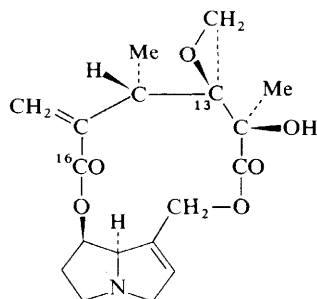

Swazine (6)

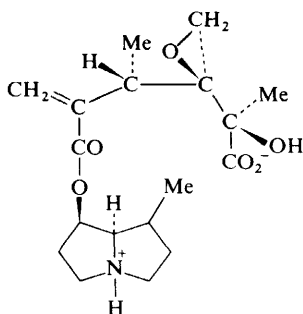

(7)

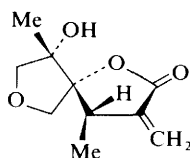

(8)

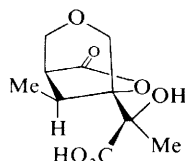

(9)

¹⁰ See ref. 1, p. 92.

¹¹ M. Laing and P. Sommerville, *Tetrahedron Letters*, 1972, 5183.

The unusual enol-ester structure (10) proposed¹² for anadoline from *Symphytum orientale* (family Boraginaceae) has been revised¹³ to the *N*-oxide structure (11). *N*-Oxides of pyrrolizidine alkaloids often give no molecular ion in the mass spectrum but give instead *M* - 16 and *M* - 18 peaks due to the tertiary base and the corresponding pyrrole respectively. (A detailed investigation of the mass spectra of *N*-oxides is discussed below.) However, under appropriate conditions a molecular ion can be detected and re-examination of the mass spectrum of anadoline revealed a peak at *m/e* 397, eighteen mass units higher than that of the previously assumed molecular ion at *m/e* 379. The *N*-oxide structure was supported by colour reactions, by hydrolysis of the alkaloid to give a product chromatographically identical with retronecine *N*-oxide, and by reduction with zinc and sulphuric acid to a tertiary base of molecular weight 381. Evidence that the tiglyl moiety of anadoline was esterified, not to C-7 of the pyrrolizidine nucleus as in the original structure (10), but to the secondary hydroxy-group of the trachelanthic acid component as in (11), was strongly indicated by electrophoretic studies. At slightly alkaline pH (9.2), pyrrolizidine alkaloids migrate as cations. At the same pH, but in the presence of borate ions, the mobilities of alkaloids containing 1,2-diol structures are either greatly reduced or reversed because of the formation of anionic borate complexes.¹⁴ Since

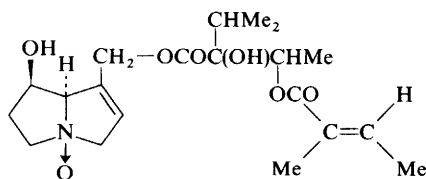
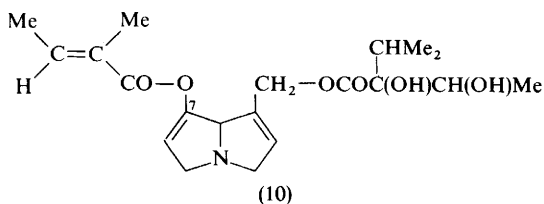

Anadoline *N*-oxide (11)

the mobility of the tertiary base from anadoline was hardly affected by the addition of borate, it was concluded that one of the hydroxy-groups of trachelanthic acid was blocked through esterification by the tiglyl component. Esterification of the secondary rather than the tertiary hydroxy-group of trachelanthic acid was readily revealed by the chemical shift of the quartet (1H) at δ 5.20, which collapsed to a singlet on irradiation of the signal due to the *Me*CH(OH)-group of the trachelanthic acid component. The C-7 hydroxy-group of the base is unesterified. Additional support for this assumption was provided by mass spectroscopy and by electrophoretic studies in the presence and absence of phosphate buffer. In the latter technique,

¹² A. Ulubelen and S. Doganca, *Tetrahedron Letters*, 1970, 2583.

¹³ C. C. J. Culvenor, J. A. Edgar, J. L. Frahn, L. W. Smith, A. Ulubelen, and S. Doganca, *Austral. J. Chem.*, 1975, **28**, 173.

¹⁴ J. L. Frahn, *Austral. J. Chem.*, 1969, **22**, 1655.

the decreased mobility of retronecine diesters in the presence of phosphate (by comparison with tris buffer, for example) is diagnostic for the presence of a C-7 ester function.¹⁴ Anadoline tertiary base, however, migrated with identical mobilities in both tris and phosphate buffers. The previously reported¹² isolation of 7-(2'-methylbutanoyl)retronecanol after hydrogenation of anadoline is now believed to be in error. To conform with standard practice it is proposed that the name anadoline should be applied to the tertiary base corresponding to (11) and that the species previously named anadoline should be referred to as anadoline *N*-oxide.

Syneilesine (12) from *Syneilesis palmata* (family Compositae) is an ester of otonecine with a new C₁₀ necic acid belonging to the senecic acid biogenetic class.¹⁵ The diester nature of the alkaloid was revealed by i.r. maxima at 1735 and 1720 cm⁻¹ and by signals in the ¹³C.n.m.r. spectrum at 171.4 and 176.7 p.p.m. Alkaline hydrolysis gave three lactones designated as syneilesinolides-A (13), B (14), and C (15). Syneilesinolide-B on hydrogenation gave a dihydro-derivative having a c.d. spectrum in which a negative Cotton effect was observed at 238 nm. Since comparable lactones with the 2*R* configuration give similar Cotton effects¹⁶ the 2*R* configuration was assigned to this lactone and hence to the necic acid in syneilesine. Hydrogenolysis of syneilesine gave, as expected, a dihydrodesoxy-derivative (16) which, on hydrolysis, gave a mixture of syneilesinolides A, B, and C, and dihydrodesoxytonecine, identical with an authentic sample. The cyclic diester nature of syneilesine (12) was clearly revealed in the non-equivalence of the C-9 protons, which gave n.m.r. signals in the form of an AB quartet, the component doublets of which were at δ 5.50 and 4.80 (*J* 11.5 Hz). The chemical shift difference of 0.7 p.p.m. between the doublets would normally be associated with an 11-membered rather than a 12-membered macrocyclic ring system.¹⁷ However, it has been noted that a number of otonecine esters have similar small chemical shift differences which overlap with the upper part of the range associated with the 11-membered cyclic diester series based on retronecine.¹⁸ The criterion of chemical

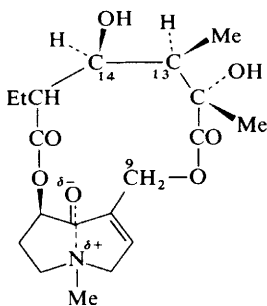

Syneilesine (12)

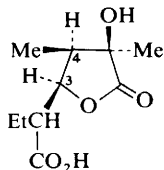

(13)

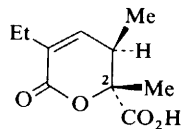

(14)

¹⁵ M. Hikichi and T. Furuya, *Tetrahedron Letters*, 1974, 3657.

¹⁶ O. Červinka, L. Hub, A. Klásek, and F. Šantavy, *Chem. Comm.*, 1968, 261; C. C. J. Culvenor, D. H. G. Crout, W. Klyne, W. P. Mose, J. D. Renwick, and P. M. Scopes, *J. Chem. Soc. (C)*, 1971, 3653.

¹⁷ L. B. Bull, C. C. J. Culvenor, and A. T. Dick, 'The Pyrrolizidine Alkaloids', North-Holland, Amsterdam, 1968, p. 44.

¹⁸ M. P. Cava, K. V. Rao, J. A. Weisbach, R. F. Raffauf, and B. Douglas, *J. Org. Chem.*, 1968, **33**, 3570; A. Klásek, P. Sedmera, and F. Šantavy, *Coll. Czech. Chem. Comm.*, 1970, **35**, 956.

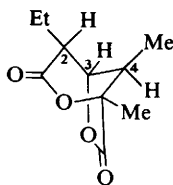

(15)

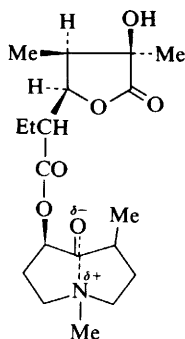

(16)

shift difference of the signals due to C-9 protons as a measure of the size of the macrocyclic ring is therefore of less value for the otonecine than for the retronecine series. Although the data in the preliminary communication are consistent with the proposed structure (12) of syneilesine, detailed arguments leading to the stereochemical assignments at C-13 and C-14 were not given. These undoubtedly depend on an analysis of the coupling constants of the methine protons at C-3 and C-4 in syneilesinolide A (13) and at C-2, C-3 and C-4 in syneilesinolide C (15) and will be forthcoming in the full paper. Syneilesine has high cytotoxic activity.

A new alkaloid, crotalarine (17) has been isolated from *Crotalaria burhia* Buch.-Ham.¹⁹ The structure (17) proposed for crotalarine is based on alkaline hydrolysis to retronecine, 3-methyl-2-pentanone, lactic acid, and a lactone, crotalaric acid (18) the i.r. spectrum of which was similar to those of monocrotalic (19) and trichodesmic (20) acids. The formation of 3-methyl-2-pentanone was reminiscent of the similar

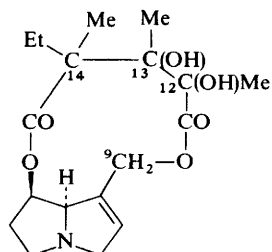

Crotalarine (17)

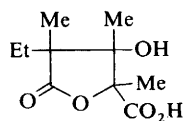

Crotalaric acid (18)

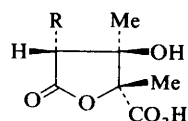
Monocrotalic acid (19) R = Me
Trichodesmic acid (20)
R = Me₂CH

formation of 2-butanone and 4-methyl-2-pentanone from monocrotaline²⁰ (21) and trichodesmine²¹ (22) respectively. Hydrogenolysis gave crotalaric acid (18) and, presumably, retronecanol. The formation of an acidic lactone on hydrogenolysis of the allylic ester function and intramolecular lactone formation with cleavage of the secondary ester group is entirely analogous to the corresponding production of

¹⁹ M. Amjad Ali and G. A. Adil, *Pakistan J. Sci. Ind. Res.*, 1973, **16**, 227.

²⁰ R. Adams and M. Gianturco, *J. Amer. Chem. Soc.*, 1956, **78**, 1922.

²¹ G. P. Menshikov and W. Rubinstein, *Chem. Ber.*, 1935, **68**, 2039.

monocrotalic and trichodesmic acids on hydrogenolysis of monocrotaline (21) and trichodesmine (22) respectively. This result also supports the proposed mode of esterification of the necic acid to the necine. The presence of a ditertiary 1,2-diol system was indicated by the slow consumption of one mole of periodate. Like monocrotaline (21) and trichodesmine (22), crotalarine (17) formed a cyclic sulphite ester (23) indicating that the hydroxy-groups could be brought readily into a *syn*

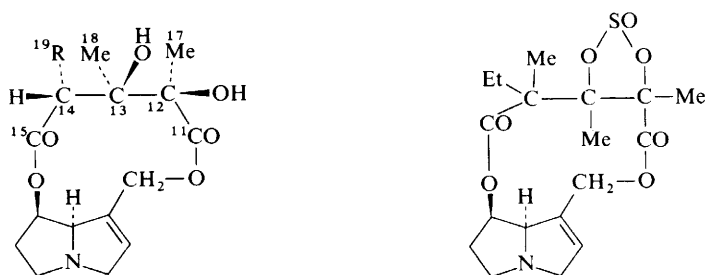

Monocrotaline (21) R = Me
Trichodesmine (22) R = Me₂CH

(23)

conformation. The chemical shift difference of 0.4 p.p.m. for the C-9 proton signals in the n.m.r. spectrum is in agreement with the 11-membered cyclic diester structure. The configurational assignments: 12*R*, 13*R*, 14*R*, were presumably assumed by analogy with monocrotaline (21) and trichodesmine (22). However, the assignments were not supported by direct evidence and require further substantiation. The proposed structure of crotalarine is of considerable interest as the necic acid is of a rare skeletal type, only two other examples of which, the necic acids from retusamine¹⁷ and emiline,²² have so far been reported.

A stereoisomer of senkirkinine (24), isosenkirkinine, has been described in a preliminary report.³ Isosenkirkinine is stated to differ in configuration from senkirkinine at C-7, C-12 and C-13, and in the configuration about the double bond of the ethylidene group.

The alkaloids of *Heliotropium eichwaldii* Steud ex DC (family Boraginaceae) have been reinvestigated.²³ In addition to the previously reported heliotrine, lasiocarpine

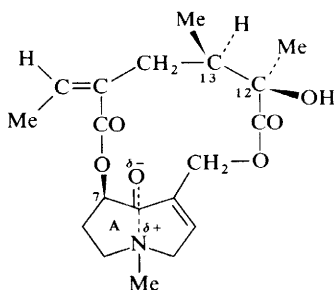

Senkirkinine (24)

²² S. Kohlmuenzer and H. Tomczyk, *Diss. Pharm. Pharmacol.*, 1971, **23**, 419; *Herba Polon.*, 1971, **17**, 226.

²³ O. P. Suri, R. S. Sawhney, and C. K. Atal, *Indian J. Chem.*, 1975, **13**, 505.

(25), its *N*-oxide and a new alkaloid, 7-angelylheliotrine (26) were isolated. The structure of this alkaloid was demonstrated by hydrogenolysis to heliotric acid and the 7 α -2'-methylbutanoyl ester of heliotridane. N.m.r., i.r., and mass spectral data were in agreement with the proposed structure.

From *Lindelofia spectabilis* Lehm (family Boraginaceae), echinatine (27), monocrotaline (21), and a new alkaloid, 7-acetylechinatine (28) were isolated.²³ The structure of the last-named alkaloid was established by acidic hydrolysis to echinatine and by hydrogenolysis to viridifloric acid and 7-acetoxyheliotridane. The occurrence of monocrotaline (21) in a plant of the family Boraginaceae, is particularly interesting as this alkaloid has previously only been found in species of *Crotalaria* (Leguminosae). However, another alkaloid, trichodesmine (22), has been long known to occur both in the Boraginaceae (*Trichodesma incana*) and in the Leguminosae (*Crotalaria* species).

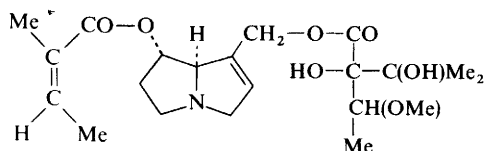

Lasiocarpine (25)

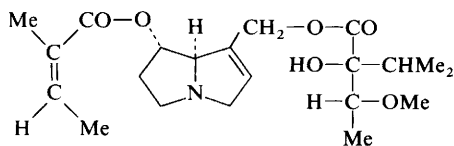

(26)

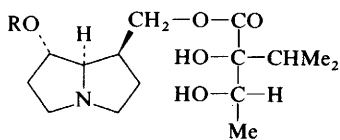
Echinatine (27) R = H
(28) R = MeCO

The structure of uluganine (29) [from *Ulugbekia tschimganica* (B. Fedtsh.) Zak (family Boraginaceae)] was elucidated entirely from n.m.r., i.r., and mass spectral data and relied heavily on comparisons with lasiocarpine and viridiflorine.²⁴ Further

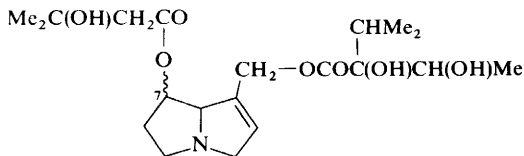

Uluganine (29)

investigation will be necessary to determine the configuration at C-7. It would also be desirable to obtain confirmatory evidence for the biogenetically acceptable but unusual (in this series) 3-hydroxy-3-methylbutanoyl residue.

In the previous Report on pyrrolizidine alkaloids (Volume 5, Chapter 4) the occurrence was noted of lycopsamine (30) in the hair pencil secretions of two

²⁴ M. A. Khasanova, U. A. Abdullaev, M. V. Telezhenetskaya, and S. Yu. Yunusov, *Khim. prirod. Soedinenii*, 1974, **10**, 809.

Australian danaid butterflies, *Danaus hamatus hamatus* (Macleay) and *Euploea tulliolus tulliolus* (Fabricius). This finding was surprising in that previously known sources of lycopsamine, *Echium lycopsis* L. and *Amsinckia* species, are thought not to occur in Queensland where the butterflies were collected. However, it has now been shown²⁵ that two species of *Parsonia*, *P. eucalyptophylla* (F. Muel.) and *P. straminea* [(R. Br.) F. Muel.] (family Apocynaceae), are widely distributed in Queensland and that these species contain lycopsamine (30), an isomer of lycopsamine (either intermidine or indicine) and, in *P. eucalyptophylla*, a third component, probably acetylintermidine or acetylindicine. The alkaloids occurred mainly in

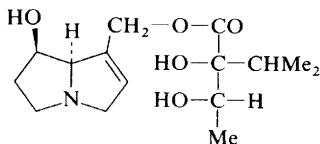

Lycopsamine (30)

the form of *N*-oxides. Although pyrrolizidine alkaloids have been found previously in species from the Apocynaceae, this report is of special interest in that the alkaloids found in the *Parsonia* species belong to the biologically active 1,2-dehydropyrrolizidine class characteristic of the Boraginaceae.

The seeds of *Crotalaria leioloba* Bartl. and *C. stipularia* Desv. contain monocrotaline. Integerrimine and trichodesmine were isolated from seed of *C. tetragona* Roxb.²⁶

Egyptian *Senecio cineraria* DC. produces senecionine, seneciphylline, jacobine and otosenine as a mixture of the free bases and the *N*-oxides.²⁷

4 X-Ray Studies

The crystal structures of two more alkaloids, heliotrine (31)²⁸ and senkirkinine (24)²⁹ have been determined. In heliotrine (31), the angle between the five-membered rings of the pyrrolizidine nucleus is 130°, which can be compared with corresponding angles of 115° for fulvine and 120° for jacobine hydrobromide. In the last-named alkaloids the hydroxy-groups at C-7 and C-9 are linked through macrocyclic ester systems. Ring A in heliotrine (31) is *endo*-puckered. This terminology refers to the angle between the planes defined by C-5, C-6, and C-7 on the one hand and C-5,

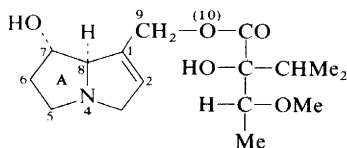

Heliotrine (31)

²⁵ J. A. Edgar and C. C. J. Culvenor, *Experientia*, 1975, **31**, 393.

²⁶ S. C. Puri, R. S. Sawhney, and C. K. Atal, *J. Indian Chem. Soc.*, 1974, **51**, 628.

²⁷ A. M. Habib, *Planta Medica*, 1974, **26**, 279.

²⁸ S. J. Wodak, *Acta Cryst.*, 1975, **B31**, 569.

²⁹ G. I. Birnbaum, *J. Amer. Chem. Soc.*, 1974, **96**, 6165.

N(4), and C-8 on the other. When this angle is such that the plane C-5, C-6, C-7 is bent into the fold of the pyrrolizidine nucleus, ring A is said to be *endo*-puckered. Conversely, when this plane is bent out from the fold of the pyrrolizidine system, ring A is said to be *exo*-puckered. In heliotrine the puckering angle is 45° .

N.m.r. studies suggested that in heliotrine a hydrogen bond is formed between the methoxy oxygen and the C-7 hydroxy-group, producing a conformation which would give the alkaloid an overall structure similar to that of a cyclic diester alkaloid.³⁰ However, in the crystal, such a conformation is not found; instead the necic acid component assumes an extended conformation directed away from the pyrrolizidine nucleus. It was seen from the crystal structure that the oxygen atom O (10) lies close to the C-1,2 double bond. Since it has been suggested that the toxicity of the alkaloids might be linked with the accessibility of this double bond, it was suggested that the observed steric hindrance due to O (10) might account for the lower toxicity of heliotrine relative to fulvine. However, it must be noted that at present there is no experimental evidence to show that steric hindrance of the C-1,2 double bond and toxicity are in any way associated.

Senkirkine (24), one of the most widely distributed *seco*-pyrrolizidine alkaloids, has an *exo*-puckered A-ring in the crystal.²⁹ The data of greatest interest emerging from the crystallographic investigation relate to the nitrogen-carbonyl interaction. The N—C distance of 2.292 Å, when inserted into Pauling's equation $D(n) = D(1) - 0.60 \log n$, gives a bond order, $n = 0.05$, if $D(1)$ is taken as 1.500 Å for an $N^+—C$ bond in which the nitrogen is substituted. When the N—C distances in four compounds (methadone, protopine, senkirkine, and clivorine) were plotted against carbonyl frequency, a straight line was obtained. If this relationship proves, on examination of further examples, to be a general one, it will be most valuable in structural investigations of *seco*-alkaloids exhibiting N-carbonyl interactions. It should be noted that the N—C bond orders for the four examples noted above are very small, in agreement with the measured carbonyl bond lengths which all lay close to the value for a normal ketone (1.215 ± 0.005 Å). It is also of interest that in both clivorine and senkirkine the oxygen atom of the carbonyl group is considerably displaced from the plane of the carbon-carbon double bond so that the two groups are essentially unconjugated.

5 General Studies

The product obtained on acetylation of clivorine (32) has been shown to be the acetate of the quaternary pyrrolinium derivative (33).³¹ The compound (33) could be converted into the chloride using an ion-exchange resin in the chloride form. The pyrrolic structure was strongly indicated by the deep violet colour given on treatment with the Ehrlich reagent. Analogous quaternary derivatives were given by other otonecine ester alkaloids.

The reduction of pyrrolizidine alkaloids on a redox polymer containing bound hydroquinone residues has been investigated.³²

³⁰ See ref. 17, p. 53.

³¹ A. Klásek, P. Sedmera, and F. Šantaŧy, *Coll. Czech. Chem. Comm.*, 1975, **40**, 568.

³² R. V. Starodubtseva, L. G. Demina, M. A. Romanchuk, T. N. Ivanov, A. S. Tevlina, and V. V. Korshak, *Khim.-Farm. Zhur*, 1974, **8**, 33.

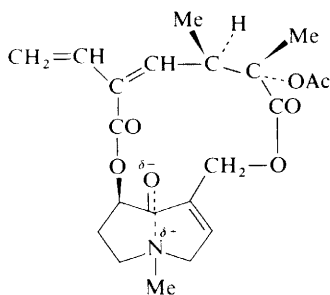

Clivorine (32)

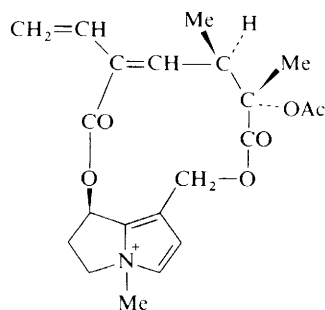

(33)

Difficulties attending the mass spectrometric analysis of pyrrolizidine *N*-oxides were encountered in the investigation of the structure of anadoline noted above. The Tashkent group³³ has carried out a detailed study of the mass spectra of *N*-oxides and has noted that a characteristic triplet of ions: $M-16$, $M-17$, and $M-18$, is usually encountered. This triplet can be used to identify the molecular ion when this is of low abundance or absent altogether. It was suggested that the $M-16$ ion arises by thermolysis of the *N*-oxide before electron impact. The characteristic fragmentations due to the *N*-oxide structure could be classified into three groups: those arising from the $M-16$ ion, those arising from the $M-17$, $M-18$ ions and those retaining the oxygen of the *N*-oxide. The last mentioned class was only observed in the spectra of saturated pyrrolizidine derivatives; the presence of Δ -1,2 unsaturation greatly enhanced the dehydration process (shown to involve the oxygen of the *N*-oxide group) leading to the formation of the $M-17$, $M-18$ ions. The most important fragmentations in which the *N*-oxide oxygen was retained were suggested to be as shown in the Scheme.

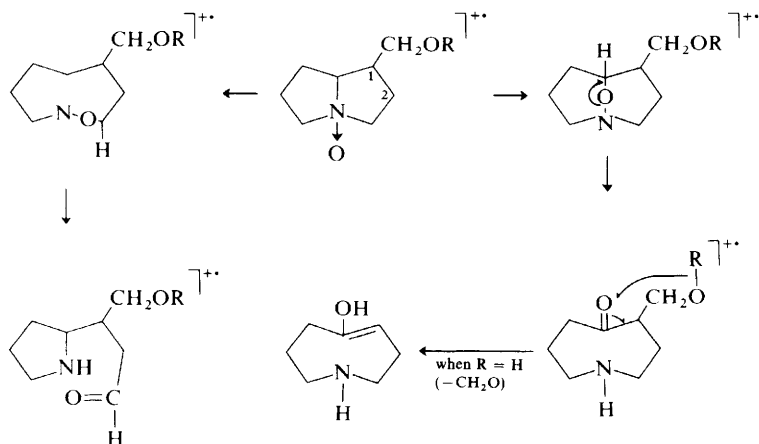

Scheme

³³ U. A. Abdullaev, Ya. V. Rashkes, and S. Yu. Yunusov, *Khim. prirod Soedinenii*, 1974, **10**, 620.

The relationship between the mass spectrum and stereochemistry of five 11-membered cyclic diesters of retronecine has been investigated.³⁴ The mass spectra of monocrotaline (21), trichodesmine (22), and fulvine (34) were observed to be very similar and significantly different from the spectrum of incanine (35), which, however, was very similar to that of crispatine (36). The major differences between the spectra of the two groups were that ions produced by McLafferty rearrangement in

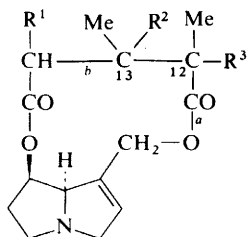
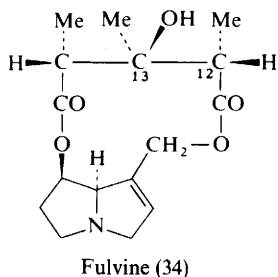

Incanine (35) $R^1 = \text{Me}_2\text{CH}$,
 $R^2 = \text{H}$, $R^3 = \text{OH}$
 Crispatine (36) $R^1 = \text{Me}$,
 $R^2 = \text{OH}$, $R^3 = \text{H}$

(21), (22), and (34) [(37) \rightarrow (38)] were relatively more abundant than corresponding ions in the spectra of crispatine (36) and incanine (35), whereas ions produced by cleavage at *a* and *b* in the spectra of the latter alkaloids were of much greater abundance than the corresponding ions in the spectra of the other three alkaloids.

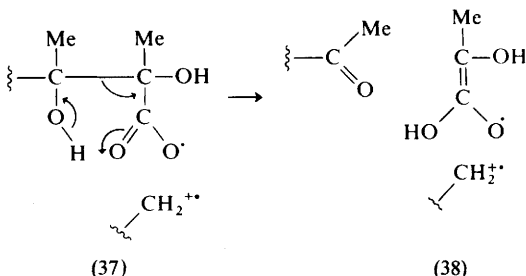

The absolute configurations of monocrotaline (21),³⁵ trichodesmine (22),³⁵ and fulvine (34)³⁶ have been unambiguously established. The structures of these alkaloids are very similar, the principal variation being the replacement of the hydroxy-group at C-12 in monocrotaline (21) and trichodesmine (22) by hydrogen in fulvine (34). Crispatine is known to have the opposite relative configuration (12*S*, 13*S* or 12*R*, 13*R*) to fulvine (12*S*, 13*R*). Since the differences between the mass spectra of these two alkaloids were assumed to depend on the relative configurational positions of the C-12 hydrogen and C-13 hydroxy-groups, it was concluded that the relative configurational positions of the C-12 hydroxy and C-13 hydrogen in incanine (35) were likewise the opposite of those in fulvine (34). This requires that

³⁴ Ya. V. Rashkes, U. A. Abdullaev, and S. Yu. Yunusov, *Khim. prirod Soedinenii*, 1974, **10**, 40.

³⁵ D. J. Robins and D. H. G. Crout, *J. Chem. Soc. (C)*, 1969, 1386.

³⁶ J. L. Sussman and S. J. Wodak, *Acta Cryst.*, 1973, **B29**, 2918.

incanine should have either the 12*S*, 13*S* or the 12*R*, 13*R* configuration. Confirmation of this conclusion by a more reliable method would be desirable.

The mass spectra of platyphylline (39), senecionine (40), and seneciphylline (41), have been reinvestigated.³⁷ The primary fission in the fragmentations of senecionine (40) and seneciphylline (41) is at the allylic C-9-O (10) bond, whereas in the spectrum of platyphylline (39), cleavage of the C-7-O (17) bond is more important.

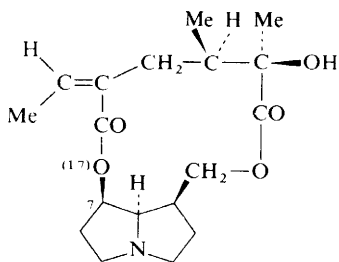

Platyphylline (39)

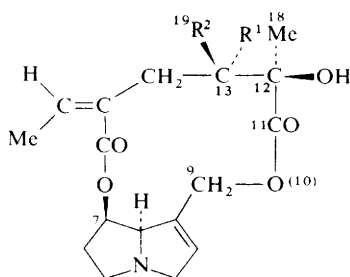

Senecionine (40) $R^1 = H, R^2 = Me$
Seneciphylline (41) $R^1, R^2 = CH_2$

6 Pharmacological Studies

Interest in the remarkable physiological properties of the pyrrolizidine alkaloids is still expanding. Several reviews covering various aspects of pyrrolizidine alkaloid toxicity have appeared.³⁸⁻⁴⁰ Recent work, some of it reported in previous Volumes, has finally settled a long-standing debate⁴¹ as to whether or not the pyrrolizidine alkaloids are truly carcinogenic, as maintained by Schoental. It has now been clearly established that malignant tumours arise in various organs of experimental animals following administration of pyrrolizidine alkaloids.^{38,42-44} When rats were pre-treated with nicotinamide with subsequent administration of heliotrine, pancreatic islet cell tumours developed.⁴² It is suggested that nicotinamide is a primary target for alkylation by pyrrolizidine alkaloid metabolites. The presence of excess nicotinamide would prevent its depletion by *N*-1 alkylation with consequent death of the cell through inactivation of many enzymes dependent on nicotinamide coenzymes. The protection thus afforded against the acute toxic action of the alkaloids would permit the expression of the mutagenic action of the alkaloids by the development of tumours. Rats treated with dehydroretrotronecine or monocrotaline developed rhabdomyosarcomas at the site of injection.⁴⁴ In addition, monocrotaline-treated rats developed myelogenous leukaemias, hepatocellular carcinomas, and pulmonary adenomas. Results of unexpected complexity were obtained when lasiocarpine, monocrotaline, or heliotropine were administered to

³⁷ U. A. Abdullaev, Ya. V. Rashkes, and S. Yu. Yunusov, *Khim. prirod. Soedinenii*, 1974, **10**, 538.

³⁸ E. K. McLean, *Israel J. Med. Sci.*, 1974, **10**, 436.

³⁹ H. F. Kraybill, *Israel J. Med. Sci.*, 1974, **10**, 416.

⁴⁰ Y. Tazima, *Mutation Res.*, 1974, **26**, 225.

⁴¹ See ref. 17, pp. 221, 233.

⁴² R. Schoental, *Cancer Res.*, 1975, **35**, 2020; *Biochem. Soc. Trans.*, 1975, **3**, 292.

⁴³ P. M. Newberne and A. E. Rogers, *Plant Foods for Man*, 1973, **1**, 23.

⁴⁴ J. R. Allen, I. C. Hsu, and L. A. Carstens, *Cancer Res.*, 1975, **35**, 997.

rats which had been pretreated with steroidal and non-steroidal compounds that affect the activity of hepatic microsomal drug-metabolizing enzymes.⁴⁵ Thus various compounds protected rats against liver damage by lasiocarpine, whereas SKF 525-A or partial hepatectomy increased lethality. However, the compounds which afforded protection against lasiocarpine enhanced the toxicity of monocrotaline and heliotrine. In addition, SKF 525-A afforded protection against monocrotaline poisoning. These differences were *not* reflected in differences in the rates of conversion of the alkaloids into the pyrrolic derivatives regarded as the active metabolites. Thus pre-treatment of rats with pregnenolone-16 α -carbonitrile or phenobarbital greatly increased the microsomal conversion of both lasiocarpine and heliotrine into pyrrolic metabolites *in vivo*. The observed toxicities are therefore determined by various factors combining in a manner not yet understood.

Administration of *Senecio jacobaea* to mice gave rise to characteristic lesions in the liver accompanied, typically, by megalocytosis.⁴⁶ However, lesions in the lungs and kidney were also observed; these lesions were accompanied by cellular enlargement. The distribution of radioactivity in the tissues of rats following administration of [³H]retronecine has been studied.⁴⁷ Activity was concentrated in the stomach mucosa. In the liver, radioactivity was located mainly in the microsomal fraction. Administration of heliotrine and lasiocarpine to sheep resulted in a lowering of the proportion of satellite DNA to total DNA.⁴⁸ Dehydroheliotridine inhibited selectively the semiconservative replication of satellite DNA in cultures of ovine kidney cells. Administration of fulvine to pregnant rats produced foetal resorption and teratogenesis.⁴⁹ Crotalaburnine (anacrotine) has been shown to exhibit marked anti-inflammatory activity towards a number of experimental oedemas.⁵⁰ A number of semisynthetic quaternary derivatives of pyrrolizidine bases and ester alkaloids have been examined for pharmacological activity.⁵¹ Several of these derivatives exhibited potent hypotensive activity. It is worth noting in connection with the last two investigations that the non-hepatotoxic alkaloid platyphylline (39) is widely used in the U.S.S.R. for the treatment of hypertension and of internal ulcers.

It has been suggested that ingestion of pyrrolizidine alkaloids by infants should be considered in the aetiology of kwashiorkor, traditionally regarded as a disease linked to protein deficiency.⁵²

⁴⁵ B. Tuchweber, K. Kovacs, M. V. Jago, and T. Beaulieu, *Res. Comm. Chem. Path. Pharmacol.*, 1974, **7**, 459.

⁴⁶ P. T. Hooper, *J. Path.*, 1974, **113**, 227.

⁴⁷ I. C. Hsu, R. C. Shumaker, and J. R. Allen, *Chem.-Biol. Interactions*, 1974, **8**, 163.

⁴⁸ C. C. Curtain, *Chem.-Biol. Interactions*, 1975, **10**, 133.

⁴⁹ T. V. N. Persaud and D. A. N. Hoyte, *Exp. Path.*, 1974, **9**, 59.

⁵⁰ M. N. Ghosh and H. Singh, *Brit. J. Pharm.*, 1974, **51**, 503.

⁵¹ K. A. Suri, R. S. Sawhney, and C. K. Atal, *Indian J. Pharm.*, 1974, **36**, 90.

⁵² R. Schoental, *Lancet*, 1974, **2**, 176, 897.

5

Indolizidine Alkaloids

BY J. A. LAMBERTON

1 *Elaeocarpus* Alkaloids

Although the *Elaeocarpus* alkaloids in which ring A is aromatic have been synthesized, the closely related dienone alkaloids, exemplified by (+)-*elaecarpiline* (1), present greater difficulties and their synthesis has not yet been achieved. An approach¹ to this ring system has been based on a modification of the Eschenmoser β -diketone synthesis. *Arecaidine* hydrochloride (2) reacted with oxalyl chloride and then hydrogen sulphide in pyridine to give a product which was then treated with 2-bromocyclohexanone in triethylamine to give α -thiolarcaidinyl cyclohexanone (3). Reaction with triethylamine, anhydrous lithium perchlorate, and triphenylphosphine then gave the two isomeric *N*-methyl-2-aza-1,2,3,4,4a,5,6,7,8,9a-decahydroxanth-9-ones (4) and (5).

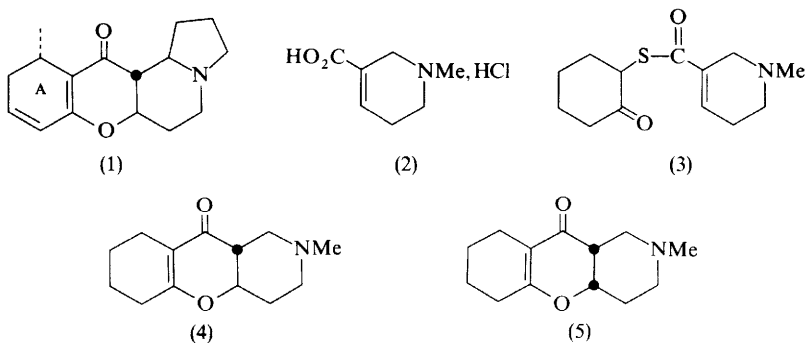

2 Pharaoh Ant Trail Pheromone

A trail substance of the Pharaoh ant, *Monomorium pharaonis* (L.), has been identified as a 3-butyl-5-methyloctahydroindolizidine of unknown stereochemistry.² The four isomers (6a—d) have now been prepared³ by methods which allow the stereochemistry at C-3, C-5, and C-9 to be assigned. Reaction of 2,6-lutidine (7) with *n*-butyl-lithium and 1,2-epoxyhexane gave the alcohol (8), which on treatment

¹ T. H. Jones and P. J. Kropp, *Tetrahedron Letters*, 1974, 3503.

² F. J. Ritter, I. E. M. Rotgans, E. Talman, P. E. J. Verweil, and F. Stein, *Experientia*, 1973, **29**, 530.

³ J. E. Oliver and P. E. Sonnet, *J. Org. Chem.*, 1974, **39**, 2662; P. E. Sonnet and J. E. Oliver, *J. Heterocyclic Chem.*, 1975, **12**, 289.

with triphenylphosphine dibromide underwent cyclization to the dihydroindolizinium bromide (9). Hydrogenation of (9) over platinum oxide then gave the *cis*-isomer (6a). The alcohol (8) was hydrogenated over platinum oxide to give the *cis*-piperidyl alcohol (10), while reduction of the alcohol (8) with sodium in ethanol gave a 4 : 1 mixture of (10) and the *trans*-isomer (11). Cyclization of these isomeric alcohols (10) and (11) by reaction with triphenylphosphine dibromide and then triethylamine gave, respectively, a mixture of (6a) and (6b) and a mixture of (6c) and (6d). The isomer (6a) could be distinguished because of its alternative synthesis from (9), and in order to assign the stereochemistry at C-3 for (6c) and (6d) another synthesis of (6d), also based on a *cis* hydrogenation of a ring, was carried out. The pyrrole (12) on hydrogenation gave the pyrrolidine (13) which, on cyclization with triphenylphosphine dibromide and triethylamine, gave a mixture of (6a) and (6d). Synthesis by this method enabled the isomer (6d), with C-3—H and C-9—H *cis*, to be distinguished.

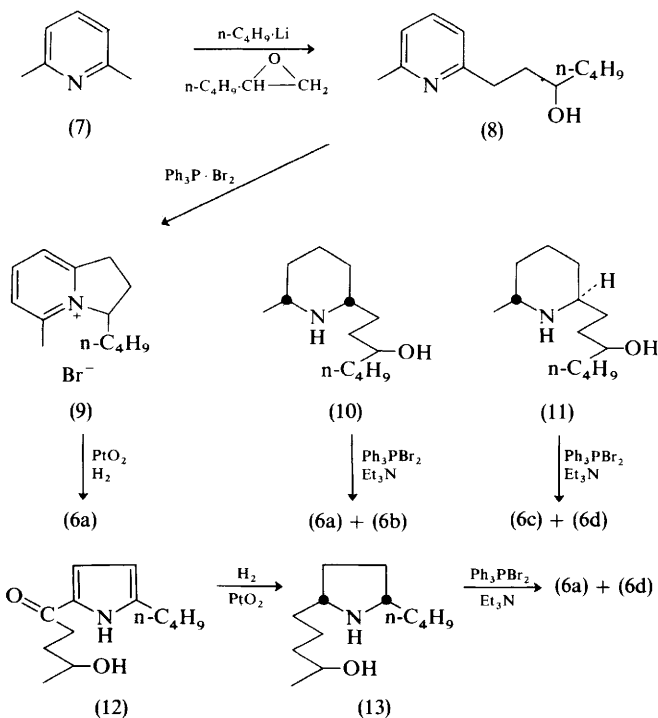
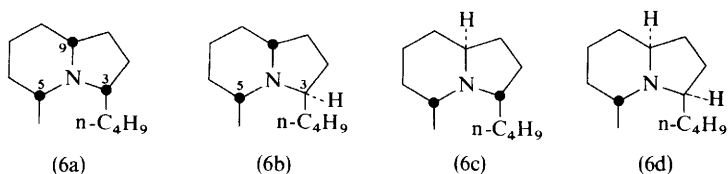

The relative intensities of Bohlmann bands at 2790 cm^{-1} , together with estimates from n.m.r. spectra of the ratio of axial to equatorial hydrogens on $-\text{CH}_2-$ groups α to nitrogen, and chemical shifts of *C*-methyl groups, have been used to study the conformations of (6a—d). The all-*cis*-isomer (6a), with a *trans* junction, has three hydrogens axial to the N lone pair on carbons α to N, but has Bohlmann bands of lower intensity than expected, and it was suggested that steric crowding between the C-3 and C-5 substituents may be relieved by a boat form for the six-membered ring with the methyl group axial.

3 Alkaloids of *Tylophora* Species

The alkaloids of leaves, stems, and roots of a number of *Tylophora* species from Sri Lanka have been investigated.⁴ In contrast to Indian *T. asthmatica* which has tylophorine (14) as the major alkaloid, eight samples of *T. asthmatica* had tylophorinine (15) as the major alkaloid and one sample contained tylophorine, tylophorinine, and tylophorinidine (16). The Sri Lankan samples, like the Indian samples, gave a very low yield of the antileukaemic alkaloid tylophorinidine. Of two

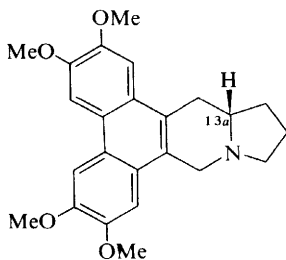

(14)

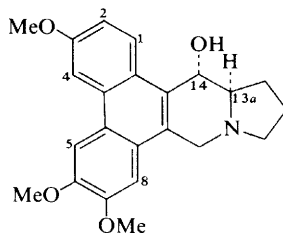

(15)

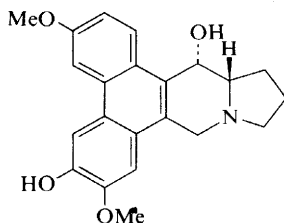

(16)

previously uninvestigated species, *T. cordifolia* contained tylophorinine and three unknown alkaloids, while *T. flava* contained tylophorine, tylophorinine, and four unknown alkaloids.

The n.m.r. spectrum of tylophorinine (15) has been discussed.⁴ It shows an unusually low field signal for C-1—H (δ 8.38) and an unusually high field signal for C-8—H (δ 6.20). To explain these observations it had previously been suggested⁵

⁴ J. D. Phillipson, I. Tezcan, and P. J. Hylands, *Planta Med.*, 1974, **25**, 301.

⁵ T. R. Govindachari, N. Viswanathan, J. Radhakrishnan, B. R. Pai, S. Natarajan, and P. S. Subramanian, *Tetrahedron*, 1973, **29**, 891.

that tylophorinine exists as an intermolecularly hydrogen-bonded dimer with interactions between the C-14 hydroxy-groups and the nitrogen lone pair. It is now argued that such a dimer can form satisfactorily only if tylophorinine assumes a flattened boat conformation for the six-membered ring of the indolizidine system, with the C-14 hydroxy-group pseudo-equatorial.

A study⁶ of the o.r.d. of 14-desoxytylophorinidine has shown a negative Cotton effect in the 200—280 nm region, in accordance with the absolute configuration (16) for tylophorinidine determined earlier by X-ray analysis. Tylophorinine, although earlier reported to be optically active, was found to be racemic, and the structure depicted (15) shows only the relative stereochemistry.

Tylophorine, tylophorinidine, and *O*-methyl tylophorinidine have been isolated from roots of *Pergularia pallida*.⁷ One minor base from this species has been identified as 3,6,7-trimethoxyphenanthroindolizidine, identical with the compound obtained by hydrogenolysis of *O*-methyl tylophorinidine.

⁶T. R. Govindachari, N. Viswanathan, and B. R. Pai, *Indian J. Chem.*, 1974, **12**, 886.

⁷N. B. Mulchandani and S. R. Venkatachalam, Atomic Energy Commission, India, Bhabha Atomic Research Centre, (Report), 1974, BARC-764, 8.

All quinolizidine alkaloids are reviewed in this Chapter, including the sesquiterpenoid *Nuphar* bases and the alkaloids of *Lythraceae* previously covered in chapters devoted to pyrrolidine, piperidine, and pyridine alkaloids.

1 The Cytisine–Lupanine–Sparteine–Matrine Group and the Ormosia Alkaloids

Occurrence.—Lupanine, retamine, *N*-methylcytisine, and anagryne were obtained from *Genista lydia*, and a new alkaloid, $C_{16}H_{24}N_2O$, of unknown structure was also isolated.¹ The alkaloids of the stem and root bark of *Cadia ellisiana* were examined, and lusitanine, multiflorine, and 13-hydroxylupanine and its ester, calpurnine, were identified; calpurnine was the major component.² A chemotaxonomic study of quinolizidine alkaloids of leguminous plants involved the identification of the alkaloids of *Baptisia leucophega*, *Thermopsis macrophylla*, *Lupinus luteus*, *L. angustifolius*, and *L. nanus*.³

New methods for the separation of the alkaloids of *Anabasis aphylla* have been described,² anabasine being conveniently isolated as its carbonate.⁴

Sophora prodanii contains sparteine and cytisine.⁵ The alkaloids of *S. alopecuroides* have been re-examined, and a new matrine alkaloid, neosophoramine, which is believed to be a stereoisomer of sophoramine (1), has been isolated.⁶

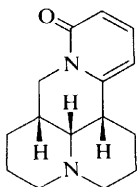

Sophoramine (1)

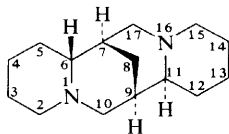

Sparteine (2)

- ¹ A. Ulubelen and T. Doguc, *Planta Med.*, 1974, **26**, 338 (*Chem. Abs.*, 1975, **82**, 95 320).
- ² G. Faugeras, R. Paris, M. Debray, J. Bourgeois, and C. Delabos, *Plant. Med. Phytotherap.*, 1975, **9**, 37 (*Chem. Abs.*, 1975, **83**, 5028).
- ³ E. K. Nowacki and G. R. Waller, *Phytochemistry*, 1975, **14**, 155.
- ⁴ V. P. Zakharov, Kh. A. Aslanov, A. S. Sadykov, and A. I. Ishbaev, *Khim. prirod. Soedinenii*, 1973, 805 (*Chem. Abs.*, 1975, **82**, 28 563); V. P. Zakharov, Kh. A. Aslanov, A. S. Sadykov, and B. A. Yankovskii, *ibid.*, 1974, p. 468 (*Chem. Abs.*, 1975, **82**, 70 267).
- ⁵ N. Paslarasu and A. Badauta-Tocan, *Farmacia (Bucharest)*, 1973, **21**, 693 (*Chem. Abs.*, 1974, **81**, 87 965).
- ⁶ T. E. Monakhova, O. N. Tolkachev, V. S. Kabanov, M. E. Perelson, and N. F. Proskurnina, *Khim. prirod. Soedinenii*, 1974, 472 (*Chem. Abs.*, 1975, **82**, 54 176).

The structures of two new alkaloids, lindenianine (15) from *Lupinus lindenianus*⁷ and albertamine (20) from *Leontice albertii*,⁸ are discussed later in this section.

Spectroscopic and Chemical Studies.—A study of the ¹³C n.m.r. spectra of over forty quinolizidine alkaloids should prove to be useful in future structural and biosynthetic work.⁹

The mass spectra of matrine alkaloids have been discussed previously (Vol. 5 of these Reports). The same Russian group has now studied the mass spectra of the *N*-oxides of matrine, allomatrine, sophoridine, isosophoridine, sophocarpine, and isosophoramine.¹⁰ In each case a peak at [*M* - 17] was observed. Klyne *et al.*¹¹ have studied the circular dichroism of some sparteine alkaloids to provide additional evidence for conformations, but concludes that there is no clear correlation with i.r. results (Vol. 4 of these Reports). Alkaloids such as sparteine (2) and α -isosparteine (2; 11 β -H), in which the tertiary amino-groups are the only chromophores present, normally show three bands in the region 190—225 nm (hexane), which disappear on acidification of a methanolic solution. The hydroxy-derivatives show similar behaviour except where special factors exist, for example the possibility of hydrogen bonding to a lone pair on nitrogen. The 2-oxo-sparteines and their 13-hydroxy-derivatives contain an additional lactam chromophore which provides two strong bands in the region 200—230 nm; a band at lower wavelength, which is negative for 11 β - and positive for 11 α -compounds, is attributable to the tertiary amine function and is obliterated with acid. 2,13-Dioxo-11 α -sparteine has a fourth band near 295 nm due to the ketonic carbonyl group, and this also disappears in the presence of acid through hemiketal formation.

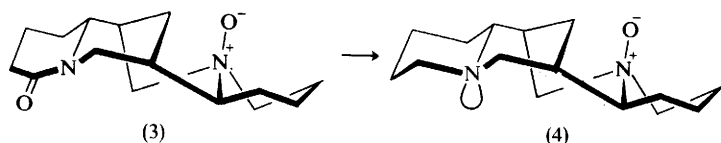

Wiewiórowski and co-workers¹² have succeeded in preparing the 'missing' sparteine *N*-16-oxide (4) in which ring C has a chair conformation. Oxidation of sparteine (2) with hydrogen peroxide furnishes the known compounds, sparteine *N*-16-oxide (7) (70%) and sparteine *N*-1-oxide (8) (30%) (Scheme 1), the ratio remaining constant irrespective of pH. The oxide (4) was not detected, apparently because only the predominant species (5) and (6) react rapidly with hydrogen peroxide. Ring C of lupanine *N*-oxide (3) was known from *X*-ray analysis to possess a boat conformation, and reduction of the compound with lithium aluminium hydride or with sodium borohydride gave the required sparteine oxide (4). As

⁷ T. Nakano, A. Castaldi Spinelli, and A. M. Méndez, *J. Org. Chem.*, 1974, **39**, 3584.

⁸ B. Sadykov, S. Iskandarov, and S. Yu. Yunusov, *Khim. prirod. Soedinenii*, 1974, 377 (*Chem. Abs.*, 1974, **81**, 152 473).

⁹ F. Bohlmann and R. Zeisberg, *Chem. Ber.*, 1975, **108**, 1043.

¹⁰ V. G. Zaikin, Z. S. Ziyavidinova, and N. S. Vul'fson, *Izvest. Akad. Nauk S.S.S.R., Ser. khim.*, 1974, 1734 (*Chem. Abs.*, 1975, **82**, 16 980).

¹¹ W. Klyne, P. M. Scopes, R. N. Thomas, J. Skolik, J. Gawroski, and M. Wiewiórowski, *J.C.S. Perkin I*, 1974, 2565.

¹² M. D. Bratek-Wiewiórowska, J. Skolik, K. Langowska, and M. Wiewiórowski, *Bull. Acad. polon. Sci., Sér. Sci. chim.*, 1974, **22**, 1025.

expected, the new oxide was a much weaker base than (7) or (8). A study of the i.r. spectra of the three oxides confirmed structure (4) for the new oxide and indicated that the other *N*-16-oxide (7) had the conformation shown. The *N*-1-oxide contains a flexible C,D ring system in which inversion at *N*-16 can occur, and probably exists in chloroform solution as the equilibrium mixture, (8)⇌(9).

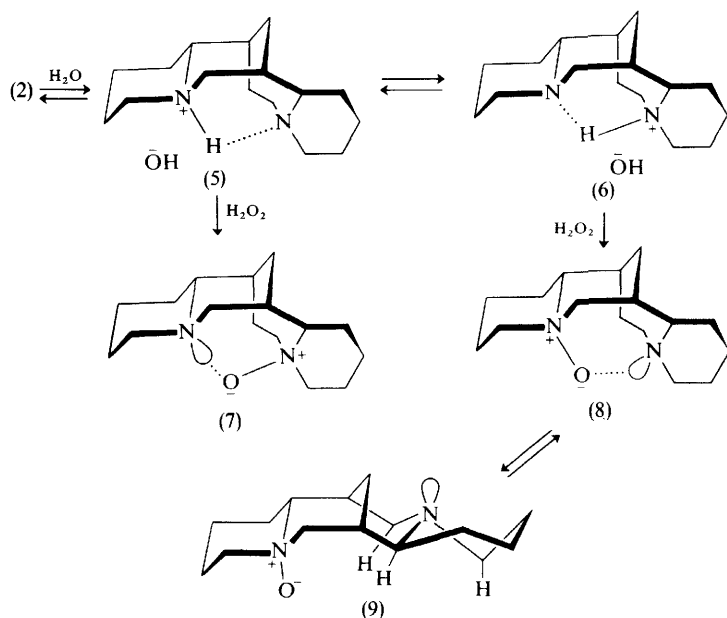

Scheme 1

A compound isolated from old extracts of *Lupinus angustifolius* seeds was shown previously to be an artefact derived from reaction of angustifoline (10) and hydroxymethylfurfural. The remaining structural features of the compound (11), including its absolute configuration, have now been established by X-ray analysis.¹³

The *N*-1-methiodides of (+)-retamine and (-)-sparteine, *cf.* (2), were prepared from retamine (12-hydroxysparteine) and sparteine, respectively, by a sequence of reactions involving oxidation to the 17-oxo-derivatives, reaction with methyl iodide, and reduction of the quaternary salts with diborane. (+)-Retamine *N*-16-methiodide is formed by direct reaction with methyl iodide, and (+)-sparteine *N*-16-methiodide is prepared by methylation of lupanine followed by reduction of the 2-oxo-function.¹⁴

The preparation of a number of derivatives (12) of aphillic acid has been described.¹⁵

¹³ J. Garbarczyk, Z. Kałuski, M. D. Bratek-Wiewiórska, J. Skolik, and M. Wiewiórowski, *Bull. Acad. polon. Sci., Sér. Sci. chim.*, 1974, **22**, 651.

¹⁴ R. Mosquera, L. Castedo, and I. Ribas, *Anales de Quim.*, 1974, **70**, 609 (*Chem. Abs.*, 1974, **81**, 136 344).

¹⁵ A. I. Ishbaev, Kh. A. Aslanov, A. S. Sadykov, and A. Nizamkhodzhaeva, *Uzbek. Khim. Zhur.*, 1974, **18**, 50 (*Chem. Abs.*, 1975, **82**, 156 539).

Full details have appeared of the determination by X-ray analysis of the absolute configuration of the *Ormosia* alkaloid, podopetaline (see Vol. 4, p. 114).¹⁶

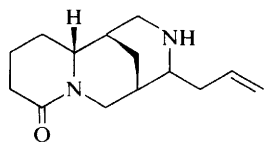

Angustifoline (10)

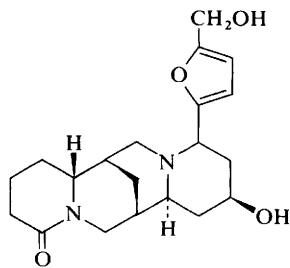

(11)

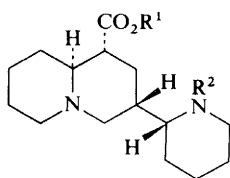

(12)

Structural Studies.—The tricyclic alkaloid, dehydroalbin, was isolated from *Lupinus albus* some time ago, and assigned structure (13). The revised structure (14) has now been established by X-ray analysis.¹⁷

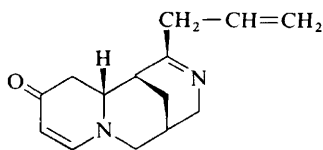

(13)

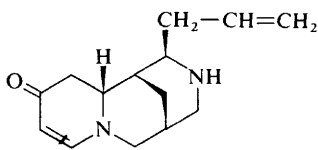

(14)

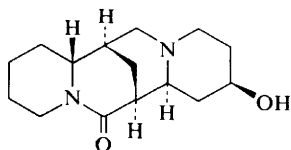

Lindenianine (15)

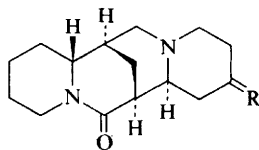

(16) R = O

(17) R = H₂

Structure (15) has been proposed for lindenianine, a new alkaloid isolated from *Lupinus lindenianus*.⁷ The presence of a hydroxy-group and a lactam carbonyl function was indicated by i.r. absorption at 3330 and at 1620 cm⁻¹, and the ring structure was defined by conversion into sparteine (2) through successive reaction

¹⁶ M. F. Mackay, L. Satzke, and A. McL. Mathieson, *Tetrahedron*, 1975, **31**, 1295.

¹⁷ A. N. Chekhlov, Z. Kafuski, Yu. T. Struchkov, J. Wolinska-Mocydlarz, and A. I. Kitaigorodskii, *Zhur. strukt. Khim.*, 1974, **15**, 950 (*Chem. Abs.*, 1975, **82**, 10 219).

with thionyl chloride and with sodium in alcohol. The keto-lactam (16), obtained by Oppenauer oxidation, was converted into (-)-aphylline (17), thus establishing the presence of a 10-oxo-group in lindenianine. The n.m.r. spectrum of the alkaloid indicates that the hydroxy-group is secondary and equatorial, and this stereochemistry is supported by formation of lindenianine from the keto-lactam (16) by borohydride reduction. The position of the hydroxy-group at C-13 was determined by correlation with 13- α -hydroxysparteine; reaction of the latter with acetic anhydride-DMSO resulted in inversion of the 13-oxygen function and formation of lindenianine acetate.

As a result of an n.m.r. study, structure (18) was assigned to the matrine alkaloid, sophoridine.¹⁸ It should be noted that this differs from the earlier proposal (19).

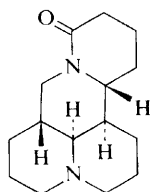

Sophoridine (18)

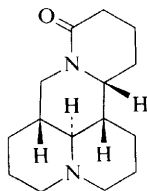

(19)

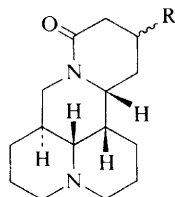
Albertamine (20) R = OH
Darvasamine (21) R = H

The constitution (20) suggested for the new alkaloid, albertamine,⁸ isolated from *Leontice albertii*, does not appear to have been established with certainty. Spectroscopic and chemical studies indicate the presence of a hydroxyl and a carbonyl group, while reaction with thionyl chloride and hydrogenation of the resultant chloro-derivative yielded darvasamine (21).

2 Sesquiterpenoid Alkaloids from Nuphar Species

6-Hydroxythiobinupharidine (22), isolated from the yellow waterlily, *Nuphar luteum*, has been studied by two groups. LaLonde and his co-workers¹⁹ showed that the alkaloid was converted by borohydride into thiobinupharidine (23), thus establishing the nature of the carbon skeleton and indicating that the hydroxy-group was part of a hemiaminal function (at C-6 or C-6'); this was confirmed by the presence in the n.m.r. spectrum of a one-proton singlet at 6.02 τ (HOCH—N). Treatment of the alkaloid with sodium borodeuteride afforded a singly-labelled thiobinupharidine; the n.m.r. spectrum of this product indicated the presence of a C-6' methylene group, in which the axial and equatorial protons were coupled, and a C-6 axial hydrogen (singlet). The incorporation of equatorial deuterium means that the hydroxy-group is situated at C-6 not at C-6', since reduction of 6,6'-dihydroxythiobinupharidine with sodium borodeuteride resulted in incorporation of equatorial deuterium at C-6 but axial deuterium at C-6'.

McLean, Wrobel, and co-workers²⁰ showed by direct comparison that 6-hydroxythiobinupharidine (22) is identical with thionupharoline isolated earlier

¹⁸ F. G. Kamaev, V. B. Leont'ev, Kh. A. Aslanov, Yu. A. Ustynuk, and A. S. Sadykov, *Khim. prirod. Soedinienii*, 1974, 744 (*Chem. Abs.*, 1975, **82**, 140 352).

¹⁹ R. T. LaLonde, C. F. Wong, and K. C. Das, *J. Amer. Chem. Soc.*, 1973, **95**, 6342.

²⁰ T. I. Martin, D. B. MacLean, J. T. Wróbel, A. Iwanow, and N. Starzec, *Canad. J. Chem.*, 1974, **52**, 2705.

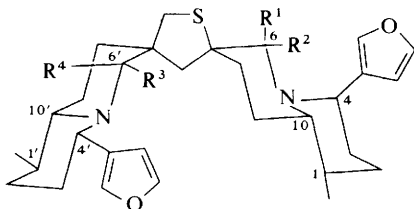

6-Hydroxythiobinupharidine (22) $R^1 + R^2 = OH + H$; $R^3 = R^4 = H$

Thiobinupharidine (23) $R^1 = R^2 = R^3 = R^4 = H$

6'-Hydroxythiobinupharidine (24) $R^1 = R^2 = H$; $R^3 + R^4 = OH + H$

from *N. luteum*, although two melting points, differing by almost 100 °C, have been reported for the diperchlorate salt. The structure of 6-hydroxythiobinupharidine was established by methods similar to those of Lalonde *et al.* but complete stereospecificity in the reactions with sodium borodeuteride was not observed. Thus, 6,6'-dihydroxythiobinupharidine furnished a mixture of dideuteriothiobinupharidine, in which deuterium at C-6' was axial but at C-6 was either axial or equatorial; the contrasting results perhaps can be attributed to differences in solvents, ethanol or methanol. A second product from this reaction proved to be [6'-²H]-6-hydroxythiobinupharidine, *cf.* (22).

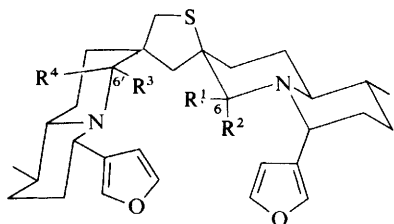

6-Hydroxythionuphlatine B (25) $R^1 + R^2 = OH + H$; $R^3 = R^4 = H$

6'-Hydroxythionuphlatine B (26) $R^1 = R^2 = H$; $R^3 + R^4 = OH + H$

In a recent paper,²¹ LaLonde has described three additional monohydroxy-derivatives, 6'-hydroxythiobinupharidine (24) and 6-hydroxythionuphlatine B (25), isolated from *N. luteum*, and 6'-hydroxythionuphlatine B (26), the major product of borohydride reduction of 6,6'-dihydroxythiobinuphlatine B. The structures of the three new hydroxy-derivatives were established by borodeuteride and spectroscopic studies.

N. luteum also yielded an unresolved mixture of 6-hydroxy- and 6'-hydroxy-neothiobinupharidine, (27) and (28), respectively, in a ratio of 23 : 79.²² The mixture, which gave a single product, neothiobinupharidine, when reduced with borohydrate, was analysed by n.m.r. and mass spectroscopy. The latter technique has proved particularly important for structural studies in this area and its application has been assisted by a useful study of the mass spectra of *Nuphar* alkaloids of the monomeric and thiospirane types.²³

²¹ R. T. LaLonde, C. F. Wong, and K. C. Das, *J. Org. Chem.*, 1974, **39**, 2892.

²² C. F. Wong and R. T. LaLonde, *Experientia*, 1975, **31**, 15.

²³ R. T. LaLonde, C. F. Wong, J. Wovlever, E. Auer, K. C. Das, and A. I.-M. Tsai, *Org. Mass Spectrometry*, 1974, **9**, 714.

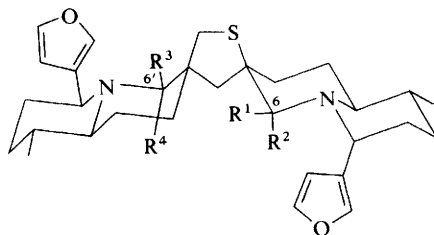

6-Hydroxyneothiobinupharidine (27) $R^1 + R^2 = H + OH$; $R^3 = R^4 = H$
 6'-Hydroxyneothiobinupharidine (28) $R^1 = R^2 = H$; $R^3 + R^4 = OH + H$

Arata *et al.*²⁴ have studied the reaction of desoxynupharidine with mercuric acetate and reduction of the resultant enamine (Scheme 2).

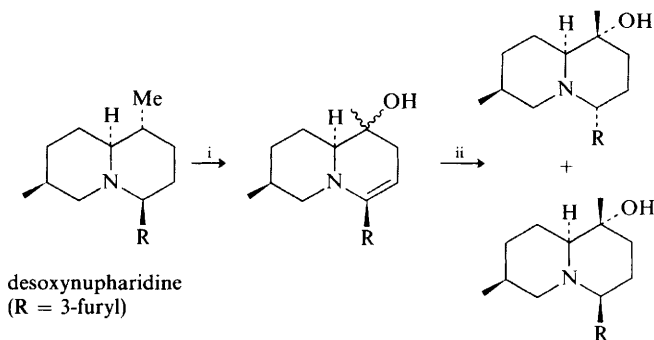

Reagents: i, $Hg(OAc)_2$; ii, $NaBH_4$

Scheme 2

3 Lythraceae Alkaloids

There has been considerable development during the year in the chemistry of lythraceae alkaloids containing quinolizidine ring systems, especially in synthesis.

A synthesis of the biphenyl ether alkaloid decaline (29) has been described previously (Vol. 5 of these Reports), and desmethyldecaline (30) has now been made by a similar route.²⁵

Lagerine, a biphenyl ether alkaloid of *Lagerstroemia indica*, was assigned structure (31),²⁶ but synthesis by the general method used for decaline gave a compound that was not identical with natural lagerine.²⁷ Comparison of the n.m.r. spectra of *O*-methyl-lagerine, which has now been isolated from *L. indica*,²⁸ and vertaline (32) showed that the two alkaloids had identical substitution patterns in ring D, but not in ring C; methyl-lagerine possesses two *ortho* aromatic protons in ring C, indicating a revised structure (34) for methyl-lagerine and (33) for lagerine. This was confirmed by synthesis of *O*-methyl-lagerine.²⁸

²⁴ Y. Arata, S. Yasuda, and R. Fujita, *Yakugaku Zasshi*, 1975, **95**, 439 (*Chem. Abs.*, 1975, **83**, 59 130).

²⁵ M. Hanaoka, N. Ogawa, and Y. Arata, *Chem. and Pharm. Bull. (Japan)*, 1974, **22**, 1945.

²⁶ J. P. Ferris, R. C. Briner, and C. B. Boyce, *J. Amer. Chem. Soc.*, 1971, **93**, 2958.

²⁷ M. Hanaoka, N. Hori, N. Ogawa, and Y. Arata, *Chem. and Pharm. Bull. (Japan)*, 1974, **22**, 1684.

²⁸ M. Hanaoka, H. Sassa, M. Ogawa, Y. Arata, and J. P. Ferris, *Tetrahedron Letters*, 1974, 2533.

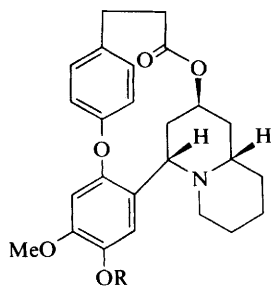

Decaline (29) R = Me
Desmethyldecaline (30) R = H

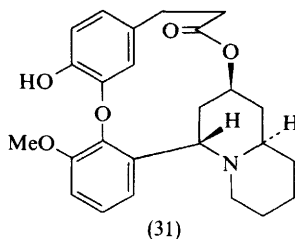

(31)

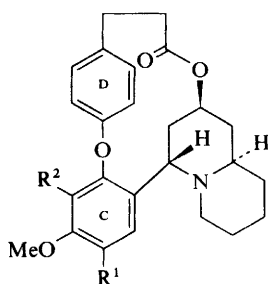

Vertaline (32) R¹ = OMe, R² = H
Lagerine (33) R¹ = H, R² = OH
O-Methyl-lagerine (34) R¹ = H, R² = OMe

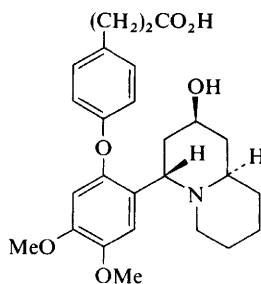

(35)

Corey's general method of electrostatically-driven cyclization of hydroxy-acids to medium and large rings has been applied to a new synthesis of vertaline (32).²⁹ The hydroxy-acid (35), obtained by hydrolysis of natural vertaline, was converted into vertaline by reaction with 2-pyridyl disulphide and triphenylphosphine. Even on a small scale the yield was 67%, and clearly this will be an invaluable cyclization procedure in the synthesis of lythraceous alkaloids.

Two groups announced almost simultaneously the synthesis of the biphenyl alkaloid methyldecinine (39) by similar routes,^{30,31} one of which is shown in Scheme 3.³¹ The synthesis proceeds in 22% yield from the biphenyl derivative (36), a key step being preferred formation of the axial alcohol (38) using iridium tetrachloride.

Abresoline (40), isolated from *Heimia salifolia* (Lythraceae),³² bears an interesting structural relationship to lythraceous alkaloids containing 12- or 14-membered rings. The structure and stereochemistry of abresoline was indicated by spectroscopy, by hydrolysis to the quinolizidol (41) and *trans*-ferulic acid, and by synthesis of dihydroabresoline. The alcohol (41) had earlier been obtained from young seedlings

²⁹ E. J. Corey, K. C. Nicolaou, and L. S. Melvin, *J. Amer. Chem. Soc.*, 1975, **97**, 654.

³⁰ M. Hanaoka, H. Sassa, C. Shimezawa, and Y. Arata, *Chem. and Pharm. Bull. (Japan)*, 1974, **22**, 1216.

³¹ B. Loev, I. Lantos, and H. Van Hoeven, *Tetrahedron Letters*, 1974, 1101.

³² R. B. Hörhammer, A. E. Schwarting, and J. M. Edwards, *J. Org. Chem.*, 1975, **40**, 656.

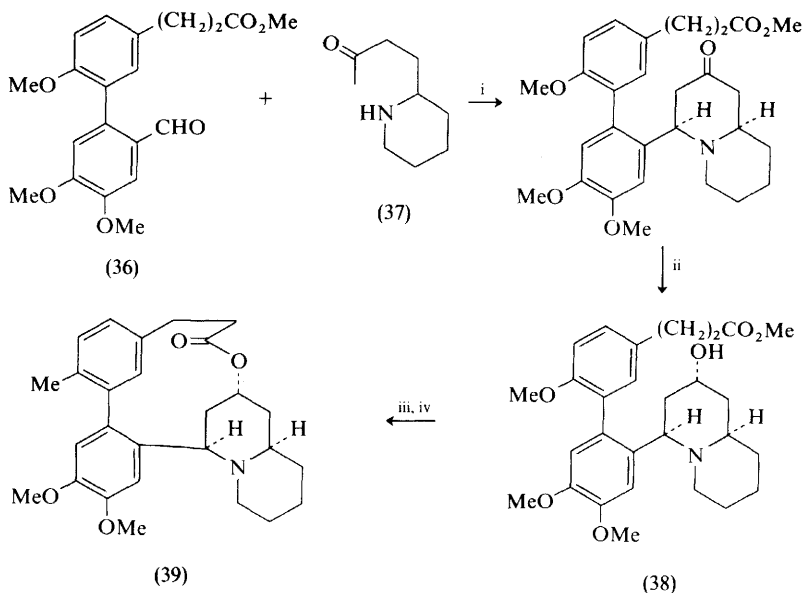

Reagents: i, KOH, aq. EtOH; ii, IrCl₄, HCl, P(OMe)₃; iii, hydrolysis; iv, MeSO₃H, PhH, heat

Scheme 3

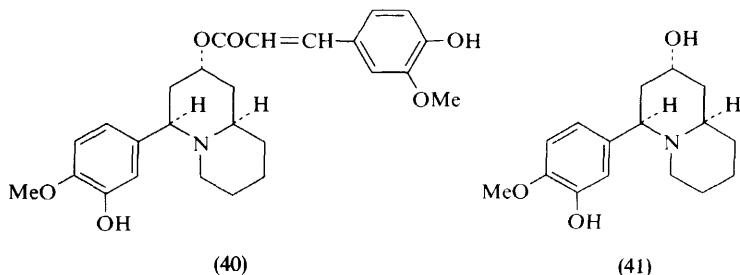

of *H. salifolia* and synthesized by reaction of isopelletierine (37) with isovanillin and treatment of the resultant quinolizidone with borohydride; as expected, the axial alcohol (41) was the minor product of the reduction.³³

4 Cryptopleurine

Cryptopleurine (45) has been prepared (Scheme 4)³⁴ by a modification of an earlier synthesis.³⁵ The key step is anodic oxidation of the known quinolizidone (42) to a mixture of compounds (43) and (44). The spiro-compound (43) was transformed in high yield into (44), which was reduced to cryptopleurine.

³³ A. Rother and A. E. Schwarting, *Experientia*, 1974, **30**, 222.

³⁴ E. Kotani, M. Kitazawa, and S. Tobinaga, *Tetrahedron*, 1974, **30**, 3027.

³⁵ J. M. Paton, P. L. Pauson, and T. S. Stevens, *J. Chem. Soc. (C)*, 1969, 1309.

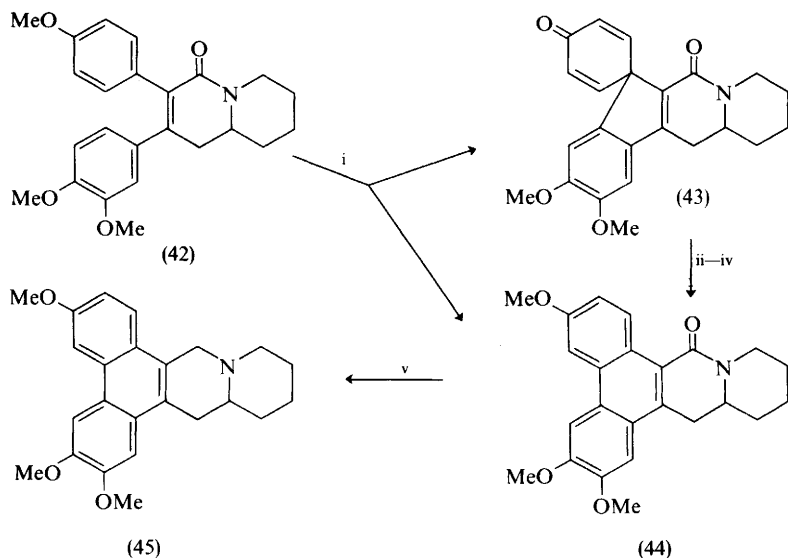

Reagents: i, anodic oxidation, MeCN, HBF₄; ii, Ac₂O, H₂SO₄; iii, OH⁻, MeOH; iv, CH₂N₂; v, LiAlH₄

Scheme 4

5 9b-Azaphenalene Alkaloids

In previous Reports the perhydro-9b-azaphenalene alkaloids derived from species of *Coccinellidae* (ladybird beetles) were discussed in the quinolizidine chapters while those isolated from the Australian shrub *Poranthera corymbosa* were included in the section devoted to miscellaneous alkaloids. In this Report the two groups of closely related alkaloids are considered together.

The 2 α -methylperhydro-9b-azaphenalenes with *cis,trans,cis* ring fusion (46) (precoccinelline) and with the *cis,cis,trans* arrangement (47) (hippodamine) were found in various species of *Coccinellidae*. Tursch and his collaborators³⁶ have now isolated the *trans,trans,trans* isomer, myrrhine (48) from *Myrra octodecimguttata*. The mass spectrum of myrrhine is virtually identical with that of compound (46) and compound (47). The stereochemistry was established by the presence of Bohlmann bands in the i.r. spectrum of the alkaloid and by correlation with coccinelline (49). Reaction of coccinelline with ethyl chloroformate furnished by *trans*-elimination an unstable enamine (50) which was reduced to a mixture of precoccinelline (46) and myrrhine (48), with the latter predominating; this sequence of reactions indicate that precoccinelline and myrrhine differ only in the configuration at one ring junction.

An alkaloid obtained from the beetle *Collomegilla maculata* is believed to be precoccinelline (46) on the basis of spectral results compared with published data, although direct comparison apparently was not made.³⁷

³⁶ B. Tursch, D. Dalozze, J. C. Braekman, C. Hootele, and J. M. Pasteels, *Tetrahedron*, 1975, **31**, 1541.

³⁷ R. D. Henson, A. C. Thompson, P. A. Hedin, P. R. Nichols, and W. W. Neel, *Experientia*, 1975, **31**, 145.

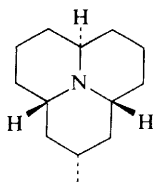

Precoccinelline (46)

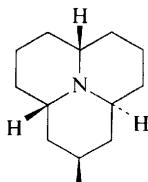

Hippodamine (47)

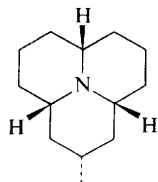

Myrrhine (48)

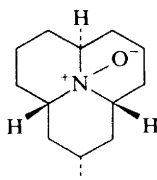

Coccinelline (49)

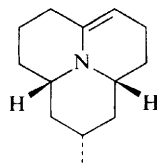

(50)

The structures of the azaphenalene alkaloids of *Poranthera corymbosa*, porantherine, porantheridine, poranthericine (51), and *O*-acetylporanthericine (52) and a related quinolizidine were determined by *X*-ray analysis (Vol. 5 of these Reports). The isolation and characterization of these alkaloids has now been described in full, and the structure of a new base, porantheriline (53), has been established.³⁸

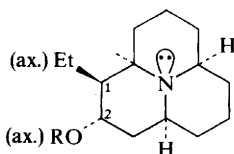

Poranthericine (51) R = H
O-Acetylporanthericine (52) R = Ac

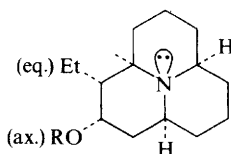

Porantheriline (53) R = Ac
 (54) R = H

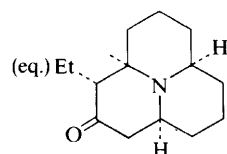

(55)

Porantheriline was shown to be an isomer of *O*-acetylporanthericine (52) by i.r. absorption at 1730 cm^{-1} (OCOME) and by the presence in the n.m.r. spectrum of resonances at τ 7.97(3H,s)(CH_3CO_2), 4.88(1H,m)(CHOAc) and 8.93(3H,s)(Me). Hydrolysis of porantheriline afforded an alcohol, isomeric with poranthericine, but oxidation of both alcohols gave the same ketone (55). The n.m.r. spectra of the two alcohols and of the two acetates indicated the presence of an equatorial C-2 proton in each compound, and it was concluded that the alcohols were epimeric at C-1 rather than at C-2. Reaction of ketone (55) with borohydride gave the alcohol (54) only, attack of the reagent apparently occurring at the least hindered β -side to give a C-2- α -axial hydroxy-group. The conversion of poranthericine into the alcohol (54) by this route and thence into porantheriline (53) by acetylation showed that the absolute configuration is the same at all centres apart from C-1.

A remarkably successful total synthesis of the tetracyclic alkaloid (\pm)-porantherine (60) by Corey and Balanson³⁹ (Scheme 5) was planned by means of

³⁸ S. R. Johns, J. A. Lamberton, A. A. Sioumis, and J. Soares, *Austral. J. Chem.*, 1975, **27**, 2025.

³⁹ E. J. Corey and R. D. Balanson, *J. Amer. Chem. Soc.*, 1974, **96**, 6516.

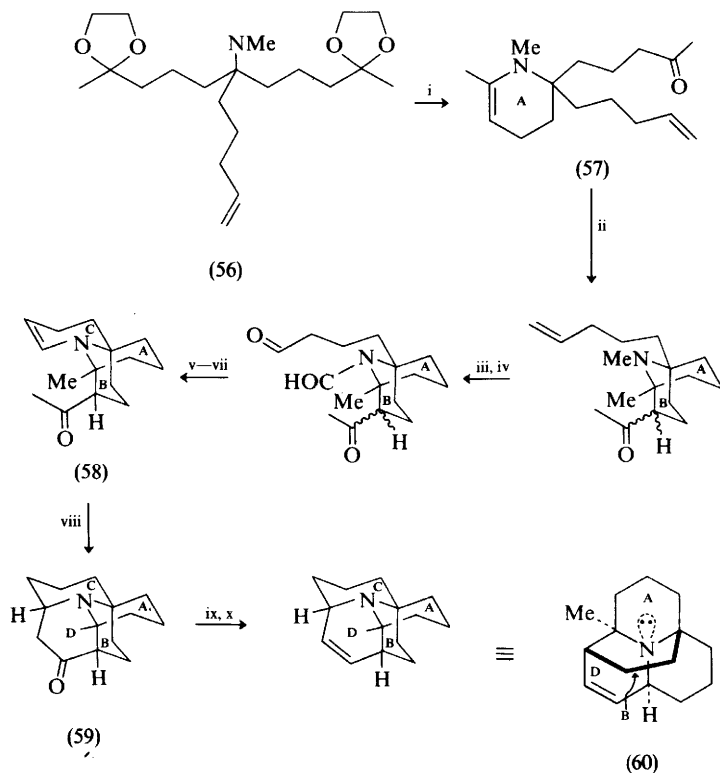

Reagents: i, 10% aq. HCl; ii, TsOH-MeCO₂C(Me)=CH₂-PhH, reflux; iii, CrO₃-py; iv, OsO₄-HClO₄; v, TsOH-(CH₂OH)₂; vi, 110 °C- OH-EtOH; vii, 10% aq. HCl; viii, 110 °C-TsOH-PhMe; ix, NaBH₄; x, SOCl₂-py.

Scheme 5

computer-assisted retrosynthetic analysis. The 6-amino-undeca-2,10-dione derivative (56), efficiently prepared in four stages from 1-chloropentan-4-one ethylene ketal, was cyclized to the Δ^2 -piperidine (57) (ring A). Ring B was formed by acid-catalyzed addition to the enamine. Removal of the *N*-methyl group and oxidation of the terminal double bond resulted in cyclization of an amino-aldehyde to give ring C, *cf.* (58). Intramolecular addition to the enamine function then furnished the tetracyclic ketone (59).

The two stereoisomers of perhydro-9b-azaphenalenone have been synthesized from the readily available perhydroboraphenalenone (61) (Scheme 6).⁴⁰ Oxidation yielded the triketone (62) which was converted by reductive amination into stereoisomer (63). This compound was transformed in six stages into isomer (64).

⁴⁰ R. H. Mueller and R. M. DiPardo, *J.C.S. Chem. Comm.*, 1975, 565.

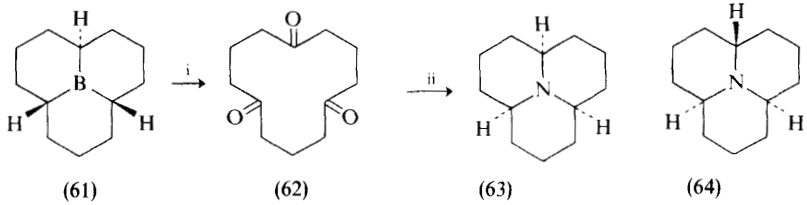

Reagents: i, RuO_4 , NaIO_4 , NaOAc ; ii, H_2 , Pd-C , NH_3 , Pr^iOH , AcOH

Scheme 6

1 Quinoline Alkaloids

Isolation and Detection.—The isolation of new quinoline alkaloids and of alkaloids of established structure that have been obtained from new sources is recorded in the Table.¹⁻¹⁶ Thin-layer chromatography is employed increasingly to recognize the presence of known quinoline alkaloids, and a useful account of the application of the method to a large group of quinoline alkaloids is now available.¹⁷ Gas-liquid chromatography was introduced for the detection and estimation of quinoline alkaloids and was applied to the analysis of basic extracts of *Skimmia* species and of *Choisya ternata*.³ A bisexual *Skimmia* hybrid contains skimmianine (1; $R^1 = H, R^2 = R^3 = OMe$) as major alkaloid and only traces of dictamnine (1; $R^1 = R^2 = R^3 = H$),³ a reversal of the situation in *S. japonica* (see ref. 25).

Further publications have appeared on the n.m.r. spectra of *Haplophyllum* alkaloids¹⁸ and on the rearrangement of allyloxy-2-quinolones observed in the mass spectrometer.¹⁹ The mass spectra of rutaceous alkaloids have been reviewed.²⁰

- ¹ D. Basu and R. Sen, *Phytochemistry*, 1974, **13**, 2329.
- ² P. G. Waterman, *Biochemical Systematics*, 1973, **1**, 153.
- ³ M. F. Grondon, D. M. Harrison, and C. G. Spyropoulos, *J.C.S. Perkin I*, 1974, 2181.
- ⁴ I. A. Benages, M. E. A. de Juarez, S. M. Albonico, A. Urzua, and B. K. Cassels, *Phytochemistry*, 1974, **13**, 2891.
- ⁵ B. F. Bowden, L. Cleaver, P. K. Ndalut, E. Ritchie, and W. C. Taylor, *Austral. J. Chem.*, 1975, **28**, 1393.
- ⁶ V. I. Akhmedzhanova, I. A. Bessonova, and S. Yu. Yunusov, *Khim. prirod. Soedinenii*, 1974, 680, (*Chem. Abs.*, 1975, **82**, 73 261).
- ⁷ I. A. Bessonova, V. I. Akhmedzhanova, and S. Yu. Yunusov, *Khim. prirod. Soedinenii*, 1974, 677 (*Chem. Abs.*, 1975, **82**, 86 462).
- ⁸ Kh. A. Abdullaeva, I. A. Bessonova, and S. Yu. Yunusov, *Khim. prirod. Soedinenii*, 1974, 684 (*Chem. Abs.*, 1975, **82**, 73 260).
- ⁹ I. Ya. Isaev and I. A. Bessonova, *Khim. prirod. Soedinenii*, 1974, 815 (*Chem. Abs.*, 1975, **82**, 121 677).
- ¹⁰ S. T. Murphy, E. Ritchie, and W. C. Taylor, *Austral. J. Chem.*, 1974, **27**, 187.
- ¹¹ T. Higa and P. J. Scheuer, *Phytochemistry*, 1974, **13**, 1269.
- ¹² K. Szendrei, M. Petz, I. Novak, J. Reisch, H. E. Bailey, and V. L. Bailey, *Herba Hung.*, 1974, **13**, 49 (*Chem. Abs.*, 1975, **83**, 40 169).
- ¹³ J. Reisch, Zs. Rózsa, K. Szendrei, and J. Körösi, *Phytochemistry*, 1975, **14**, 840.
- ¹⁴ A. G. Gonzalez, R. Estevez Reyes, and E. Diaz Chico, *Anales de Quim.*, 1974, **70**, 281 (*Chem. Abs.*, 1974, **81**, 117 048).
- ¹⁵ J. Vaquette, J. L. Pousset, and A. Cave, *Plant. Med. Phytother.*, 1974, **8**, 72 (*Chem. Abs.*, 1974, **81**, 60 859).
- ¹⁶ N. Decandain, N. Kunesch, and J. Poisson, *Phytochemistry*, 1974, **13**, 505.
- ¹⁷ Zs. Rózsa, K. Szendrei, I. Novak, E. Minker, M. Koltai, and J. Reisch, *J. Chromatog.*, 1974, **100**, 218.
- ¹⁸ K. L. Seitanidi and M. R. Yagudaev, *Khim. prirod. Soedinenii*, 1974, 755 (*Chem. Abs.*, 1975, **82**, 171 259).
- ¹⁹ Ya. V. Rashkes, I. A. Bessonova, and S. Yu. Yunusov, *Khim. prirod. Soedinenii*, 1974, 364 (*Chem. Abs.*, 1974, **81**, 152 456).
- ²⁰ J. Reisch, K. Szendrei, I. Novak, and E. Minker, *Acta Pharm. Hung.*, 1974, **44**, 107 (*Chem. Abs.*, 1974, **81**, 111 410).

Table Isolation of quinoline alkaloids

Species	Alkaloid (structure)	Ref.	
<i>Aegle marmelos</i>	Haplopine (1; R ¹ = H, R ² = OH, R ³ = OMe)	1	
<i>Araliopsis tabonensis</i>	(+)-N-Methylplatydesminium salt (19)	2	
<i>Choisya ternata</i>	7-Isopentenyl-oxo- γ -fagarine (7)	3	
<i>Diphasia klaineana</i>	Skimmianine (1; R ¹ = H, R ² = R ³ = OMe)	2	
<i>Fagara mayu</i>	Dictamnine (1; R ¹ = R ² = R ³ = H)	4	
	γ -Fagarine (1; R ¹ = R ² = H, R ³ = OMe)	4	
	Skimmianine	4	
<i>Flindersia pimenteliana</i>	Dictamnine	5	
	Skimmianine	5	
<i>Haplophyllum perforatum</i>	*Haplophydine (11)	8	
	*Glycoferine (8)	6	
	7-Isopentenyl-oxo- γ -fagarine (7)	7	
<i>H. kowalenskyi</i>	} γ -Fagarine	9	
<i>H. schelkownikovii</i>		} Skimmianine	9
<i>H. tenue</i>			
<i>H. villosum</i>			
<i>Melicope perspicuinervia</i>	Halfordinine (9)	10	
	Kokusaginine (1; R ¹ = R ² = OMe, R ³ = H)	10	
	(\pm)-Platydesmine (21)	10	
	Skimmianine	10	
<i>Pelea barbiger</i>	(+)-Edulinine (20)	11	
	Kokusaginine	11	
	*Isoplatydesmine (22)	11	
<i>Ptelea trifoliata</i>	Lunidonine (2; R = Me)	12	
	*N-Desmethyl-lunidonine (2; R = H)	12	
	*2-(n-Undecyl)-4-quinolone (5; n = 10)	13	
<i>Ruta bracteosa</i>	Rutamine (graveoline) (4)	14	
<i>Skimmia japonica</i>	γ -Fagarine	3	
	5-Hydroxy-1-methyl-2-phenyl-4-quinolone (3)	3	
<i>Teclea unifoliata</i>	Kokusaginine	15	
	Maculine (1; R ¹ R ² = OCH ₂ O, R ³ = H)	15	
	Skimmianine	15	
<i>Zanthoxylum tsihanimposa</i>	γ -Fagarine	16	
	Skimmianine	16	

* New alkaloids.

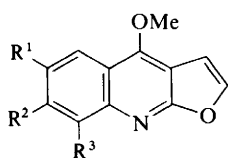

(1)

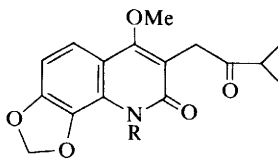

(2)

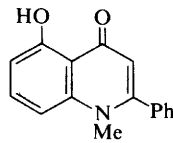

(3)

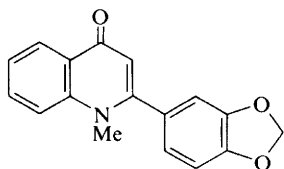

(4)

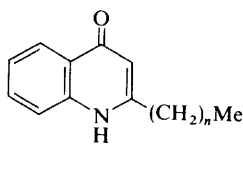

(5)

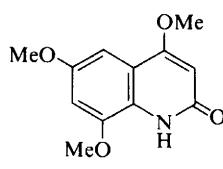

Halfordamine (6)

Quinoline Alkaloids without 3-Substituents.—4-Quinolones with a long-chain alkyl group in the 2-position were obtained originally from fungi, but in recent years have been shown to be present in some higher plants. A new alkaloid, 2-(*n*-undecyl)-4-quinolone (5; *n* = 10), has now been isolated from *Ptelea trifoliata* and its structure established by spectral data.¹³ The roots of *Ruta graveolens* contain an unresolved mixture of alkylquinolones (5; *n* = 10—13).¹³

5-Hydroxy-1-methyl-2-phenyl-4-quinolone (3), obtained previously from *Lunasia quercifolia*, now has been isolated from *Skimmia japonica*.³ Details have been published of the Italian synthesis of halfordamine (6) (see Vol. 4 and Vol. 5 of these Reports) and related 2-quinolones.²¹

Furoquinoline Alkaloids.—The isopentenylxyfuroquinoline first obtained from *Ptelea aptera*²² and recently isolated from *Choisya ternata*³ and from *Haplophyllum perforatum*⁷ was believed to be 7-isopentenylxy- γ -fagarine (7), although the alternative 8-isopentenylxy-7-methoxy arrangement was not excluded rigorously. Structure (7) has now been confirmed by the preparation of the alkaloid from haplopine (1; R¹ = H, R² = OH, R³ = OMe) by reaction with 1-chloro-3-methylbut-2-ene.⁷

Halfordinine, found earlier in *Halfordia scheroxyla*, clearly was a trimethoxydic-tamnine, but its constitution was not established. The alkaloid has since been isolated from *Melicope perspicuinervia* and shown to be 6,7,8-trimethoxydictamnine (9) by catalytic reduction followed by acid treatment to give the 3-ethylquinolone (10); the latter was synthesized from 2,3,4-trimethoxyaniline.¹⁰ In halfordinine (9) and in kokusaginine (1; R¹ = R² = OMe, R³ = H) the expected nuclear Overhauser effect was not observed, since the C-5—H apparently is mainly relaxed by the C-6—OMe rather than by the C-4—OMe; the latter is involved only with relaxation of C-3—H.¹⁰

Two new furoquinoline alkaloids, glycoferine and haplophydine, were obtained from *Haplophyllum perforatum*. The structure of glycoferine (8) was determined by hydrolysis to haplopine (1; R¹ = H, R² = OH, R³ = OMe) and L-rhamnose.⁶ Spec-

²¹ P. Venturella, A. Bellino, and F. Piozzi, *Gazzetta*, 1974, **104**, 297.

²² D. L. Dreyer, *Phytochemistry*, 1969, **8**, 1013.

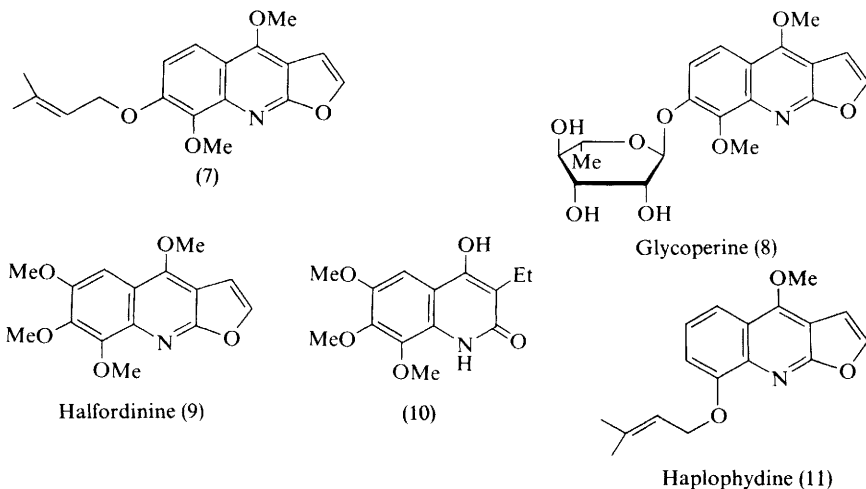

troscopic studies indicate that haplophydine is 8-isopentenylxydictamnine (11), but confirmation, for example by synthetic correlation with robustine (1; $R^1 = R^2 = H$, $R^3 = OH$), itself a constituent of *Haplophyllum* species, is desirable.

A full account has been published of the recent syntheses of dictamnine, pteleine, and evolitrine (see Vol. 5 of these Reports), and the method has been extended to γ -fagarine (1; $R^1 = R^2 = H$, $R^3 = OMe$).²³

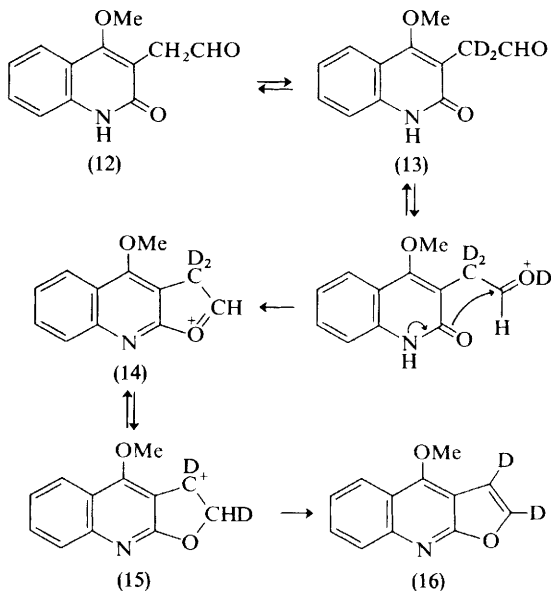

Scheme

²³ N. S. Narasimhan and R. S. Mali, *Tetrahedron*, 1974, **30**, 4153.

The labelled furoquinolines [2,3- $^3\text{H}_2$]- and [2,3- $^2\text{H}_2$]-dictamnine (16) were prepared by reaction of aldehyde (12) with tritiated or deuteriated polyphosphoric acid. These compounds were useful for biosynthetic studies, since isotope exchange did not occur readily, for example after prolonged treatment with acid.³ A possible mechanism for the formation of [2,3- $^2\text{H}_2$]dictamnine is shown (Scheme), the exchange of deuterium between C-2 and C-3 occurring in the equilibrium, (14) \rightleftharpoons (15), although a plausible alternative involves exchange of the aldehyde proton of (13) through addition of D^+ to the enol form assisted by the methoxy-group.³

3-Prenylquinoline Alkaloids.—This group includes those alkaloids derived notionally by cyclization of a 3-prenyl substituent. This process was used to synthesize the pyranquinolone alkaloid, haplamine (18), which was formed by reaction of the 3-prenyl derivative (17) with DDQ.²⁴

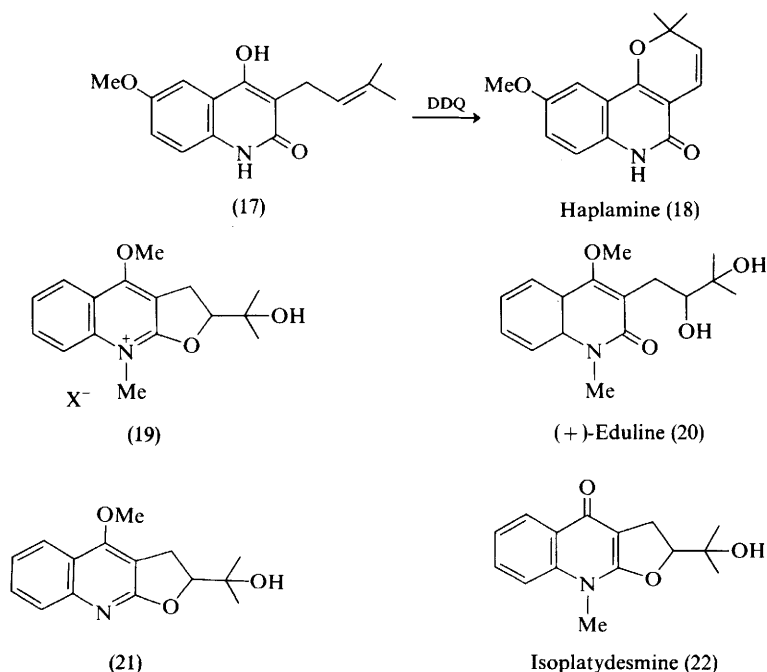

Investigation of the alkaloids of *Pelea barbiger* led to the isolation of (+)-eduline (20),¹¹ obtained previously from other rutaceous species only in the enantiomeric form. (–)-Eduline from *Skimmia japonica* is an artefact derived from (+)-platydesminium metho-salt (19) by base treatment during isolation.²⁵ Although (+)-eduline was also shown to be an artefact, presumably arising from (–)-platydesminium metho-salt, it was not possible to detect the quaternary salt in *P. barbiger*.¹¹ Another interesting constituent of the *Pelea* species is isoplatydesmine (22), also obtained from (+)-platydesmine (21) by successive treatment with methyl

²⁴ P. Venturella, A. Bellino, and F. Piozzi, *Heterocycles*, 1975, **3**, 367.

²⁵ D. R. Boyd and M. F. Grundon, *J. Chem. Soc. (C)*, 1970, 556.

iodide and pyridine.¹¹ Isoplatydesmine has not been found hitherto as a natural compound, although the racemate was synthesized some years ago.²⁶

A further study of the constituents of *Ptelea trifoliata* resulted in the isolation of lunidonine (2; R = Me), previously obtained from *Lunasia amara*, and of the new alkaloid, *N*-desmethyl-lunidonine (2; R = H).¹²

2 Quinazoline Alkaloids

The quinazolines, vasicinone (23; R = OH), vasicine (24; R¹ = H, R² = OH) and vasicinol (24; R¹ = R² = OH) have been obtained from *Sida cordifolia* L. (Malvaceae). These are the first alkaloids, apart from β -phenylethylamine derivatives, to have been isolated from this genus.²⁷

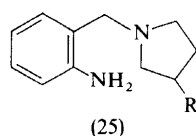
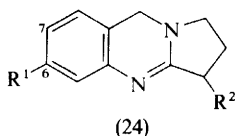
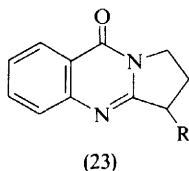

A study of the reactions of quinazolines with sodium borohydride resulted in the reduction of the carbon-nitrogen double bonds in compounds (23; R = H or OH), and reductive cleavage of the deoxy-derivatives (24; R¹ = H, R² = H or OH) to pyrrolidines (25; R = H or OH).²⁸

Desoxyvasicine (24; R¹ = R² = H) and substituted derivatives (24; R¹ = Cl, Br, or NH₂, R² = H) were synthesized by reaction of anthranilic acids with 2-pyrrolidone, followed by reduction with zinc and hydrochloric acid.²⁹

3 Acridone Alkaloids

The structure (26) assigned to atalaphylline, a new acridone of *Atlanta monophylla*, was based on spectral data and on the conversion of the alkaloid by heating with formic acid followed by reduction into the known compound, bicycloatalaphylline (27).³⁰

The bark of the shrub *Tecelea boivincana* contains melicopicine (29; R¹ = R² = OMe), tecleanthine (28; R¹ = H, R² = OMe) and evoxanthine (28; R¹ = R² = H). Two new acridone alkaloids, 6-methoxytecleanthine (28; R¹ = R² = OMe) and 1,3,5-trimethoxy-10-methylacridone (30) were also isolated and their structures determined, mainly by means of n.m.r. spectroscopy.³¹ *Diphasia klaineana*, another member of the sub-family Toddaloidea (Rutaceae) contains evoxanthine (28; R¹ = R² = H) and arborinine (29; R¹ = OH, R² = H).²

²⁶ R. M. Bowman and M. F. Grundon, *J. Chem. Soc. (C)*, 1966, 1504.

²⁷ S. Ghosal, R. Ballav, P. S. Chankan, and R. Mehta, *Phytochemistry*, 1975, **14**, 830.

²⁸ B. Zh. Zharekeev, M. V. Telezhenetskaya, Kh. N. Khashimov, and S. Yu. Yunusov, *Khim. prirod. Soedinenii*, 1974, 679 (*Chem. Abs.*, 1975, **82**, 73 290).

²⁹ Kh. Shakhidoyatov, A. Irishbaev, and Ch. Sh. Kadyrov, *Khim. prirod. Soedinenii*, 1974, 681 (*Chem. Abs.*, 1975, **82**, 86 470).

³⁰ S. C. Basa, *Phytochemistry*, 1975, **14**, 835.

³¹ J. Vaquette, M. O. Cleriot, M. R. Paris, J. L. Pousset, A. Cave, and R. R. Paris, *Plant. Med. Phytother.*, 1974, **8**, 57 (*Chem. Abs.*, 1974, **81**, 60 857).

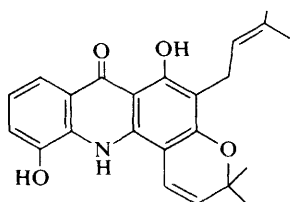

(26)

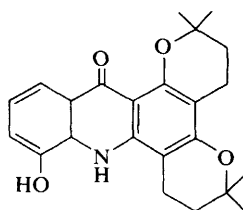

(27)

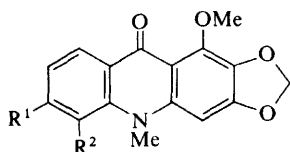

(28)

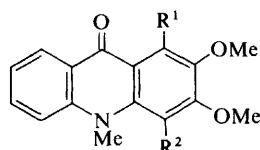

(29)

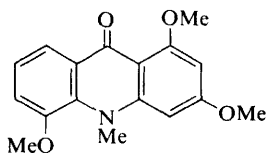

(30)

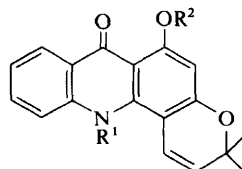

(31)

As part of a general study of the synthesis of 2,2-dimethylpyrano-derivatives, a convenient synthesis of the acridone alkaloid, acronycine (31; $R^1 = R^2 = \text{Me}$) was devised.³² Heating a solution of 1,3-dihydroxyacridone and 4,4-dimethoxy-2-methylbutan-2-ol in pyridine afforded a mixture of linear and angular pyrano derivatives. The angular product (31; $R^1 = R^2 = \text{H}$), which predominated, is itself a natural compound and was converted by methylation into acronycine.

³² W. M. Bandaranayake, M. J. Begley, B. O. Brown, D. G. Clarke, L. Crombie, and D. A. Whiting, *J.C.S. Perkin I*, 1974, 998.

1 General

A useful compendium of data on isoquinoline alkaloids has been published, this second volume bringing literature coverage in the series up to 1972.¹ An introductory section deals with recent structure determinations, syntheses, and biogenetic correlations. A more general compilation includes new alkaloids described in 1973.² The structure and absorption spectroscopy of steroids and alkaloids are the subject of another volume.³ Outstanding items in alkaloid literature during 1973 have been summarized.⁴

The distribution of alkaloids in higher plants is the subject of a review⁵ and also forms part of a more comprehensive treatise on plant products.⁶ In this particular volume coverage includes a number of families which yield isoquinoline alkaloids (Hydrastidaceae, Ranunculaceae, Rhamnaceae, Rubiaceae, Rutaceae, and Violaceae). The chemistry and pharmacology of Chinese drugs in Taiwan have been reviewed, protoberberine, aporphine, and tetrahydrobenzylisoquinoline alkaloids being amongst the constituents listed.⁷ In continuation of previous screening studies, almost a quarter of a further 2001 plants examined gave positive tests for alkaloids.^{8,9} The alkaloid composition of the stamens of *Papaver somniferum* at different stages of their development has been studied.¹⁰

Studies on extraction of alkaloids by oleic acid solutions¹¹ and by organic solvents at different pHs¹² have been described. The stability of various alkaloids to precipitating reagents has been examined.¹³ Reviews on the chromatography of

¹ T. Kametani, 'The Chemistry of the Isoquinoline Alkaloids. Vol. 2.', Hirokawa Publishing Co. Inc., and Elsevier, Amsterdam, 1974.

² 'Dictionary of Organic Compounds. 4th Edition. 10th and Cumulative Supplement', ed. Miss J. B. Thomson, Eyre and Spottiswoode, London, 1974.

³ M. Kraft, 'Struktur und Absorption Spektroskopie der Steroide und Alkaloide', Thieme, Stuttgart, 1975.

⁴ H. F. Hodson, *Ann. Reports (B)*, 1973, **70**, 530.

⁵ G. V. Lazurevskii and I. V. Terenteva, *Khim. prirod. Soedinenii*, 1974, **3**, 337.

⁶ R. Hegnauer, 'Chemotaxonomy of Plants', Birkhauser Verlag, Basel, 1973, Vol. 6.

⁷ H.-Y. Hsu and Y.-P. Chen, *Heterocycles*, 1975, **3**, 265.

⁸ S. J. Smolenski, H. Silinis, and N. R. Farnsworth, *Lloydia*, 1974, **37**, 507.

⁹ S. J. Smolenski, H. Silinis, and N. R. Farnsworth, *Lloydia*, 1975, **38**, 225.

¹⁰ Y. M. El Kheir, *Planta Med.*, 1975, **27**, 275.

¹¹ L. Jusiak, *Acta Polon. Pharm.*, 1974, **31**, 379 (*Chem. Abs.*, 1975, **82**, 77 064).

¹² V. F. Kramarenko, *Farmatsiya (Moscow)*, 1974, **23**, 29 (*Chem. Abs.*, 1975, **82**, 64 386).

¹³ H. Kucerova, M. Kucerova, and C. D. Essien, *Planta Med.*, 1975, **27**, 185.

alkaloids using ion-exchange resins,^{14,15} the BN chamber (t.l.c.),¹⁶ and high-speed liquid chromatography¹⁷ have appeared.

The u.v., i.r., and ¹H n.m.r. absorptions of 1000 simple aromatic compounds substituted by hydroxy-, methoxy-, and methylenedioxy-groups have been collected as a possible aid to identification of alkaloid degradation products.¹⁸ Homobenzylic and homoallylic spin-spin coupling interactions in some octahydro- and hexahydro-phenanthridines have been discussed.¹⁹

Cuprous thiophenolate in refluxing pyridine has been recommended for direct *N*-demethylation of quaternary ammonium iodides.²⁰

Excellent reviews are available concerning the synthesis of various types of isoquinoline alkaloids by phenolic cyclization,²¹ by biogenetic type reactions,²² by the thermolysis of benzocyclobutanes,²³ and by the coupling of phenols or of related non-phenolic compounds.²⁴

2 β -Phenethylamine Alkaloids

Alkaloid isolations and structural elucidations are summarized in Table 1. A new quaternary alkaloid, 4-hydroxy-3-methoxy-phenethyltrimethylammonium hydroxide, has been isolated from *Alhagi pseudalhagi*.²⁵ *N*-Methyltyramine is another new compound isolated from this plant. *Desmodium cephalotes* afforded three phenethylamine bases together with candicine and other unidentified quaternary bases.²⁶ Candicine has also been found, together with other alkaloids, in various *Zanthoxylum* species (*Z. americanum*,²⁷ *Z. avicennae*,²⁸ and *Z. clava-herculis*²⁷). Tyramine has been isolated from three species of *Magnolia*, viz. *M. denudata*, *M. liliiflora*, and *M. obovata*, and been shown to be present in appreciable amounts in two others, *M. kobus* and *M. grandiflora*.²⁹ The first occurrence in Nature of the well-known synthetic intermediate *N*-homoveratroyl homoveratrylamine has been reported.³⁰ It occurs in the leaves of *Pleiospermium alatum*³⁰ together with two other amides, *N*-benzoyl-4-methoxyphenethylamine and (*E*)-*N*-4-methoxystyrylbenzamide³¹ ('alatamide'). Another amide, *N*-benzoyl-L-phenylalaninol has been isolated from *Alangium lamarckii*.³² The only other known plant source of this is *Catharanthus pusillus*. The roots of *Sida cordifolia* contain three sympathomimetic

¹⁴ P. Jandera and J. Churacek, *J. Chromatog.*, 1974, **98**, 1.

¹⁵ H. F. Walton, *J. Chromatog.*, 1974, **102**, 57.

¹⁶ S. F. Cooper and R. Dugal, *J. Chromatog.*, 1974, **101**, 395.

¹⁷ R. Verpoorte and S. A. Baerheim, *J. Chromatog.*, 1974, **100**, 227.

¹⁸ F. Santavy, S. Hegerova, L. Hruban, A. Klasek, A. Nemeckova, V. Simanek, and D. Walterova, *Acta Univ. Palacki. Olomuc Fac. Med. Suppl.*, 1973, **13**, 134, (*Chem. Abs.*, 1974, **81**, 25 219).

¹⁹ A. C. Hiutric, B. R. Lowry, and A. E. Weber, *J. Org. Chem.*, 1975, **40**, 965.

²⁰ G. H. Posner and J.-S. Ting, *Synthetic Comm.*, 1974, **4**, 355.

²¹ T. Kametani and K. Fukumoto, *Heterocycles*, 1975, **3**, 311.

²² T. Kametani, K. Fukumoto, and F. Satoh, *Bio-org. Chem.*, 1974, **3**, 430.

²³ T. Kametani and K. Fukumoto, *Heterocycles*, 1975, **3**, 29.

²⁴ S. Tobinaga, *Bio-org. Chem.*, 1975, **4**, 110.

²⁵ S. Ghosal, R. S. Srivastava, S. K. Bhattacharya, and P. K. Debnath, *Planta Med.*, 1974, **26**, 318.

²⁶ S. Ghosal and R. Mehta, *Phytochemistry*, 1974, **13**, 1628.

²⁷ F. Fish, A. I. Gray, P. G. Waterman, and F. Donachie, *Lloydia*, 1975, **38**, 268.

²⁸ F. Fish, A. I. Gray, and P. G. Waterman, *Phytochemistry*, 1975, **14**, 841.

²⁹ M. Matsutani and T. Shiba, *Phytochemistry*, 1975, **14**, 1132.

³⁰ A. B. Kundu and M. Chakrabarty, *Chem. and Ind.*, 1975, 433.

³¹ A. Chatterjee, M. Chakrabarty, and A. B. Kundu, *Austral. J. Chem.*, 1975, **28**, 457.

³² B. Achari, A. Pai, and S. C. Pakrashi, *Indian J. Chem.*, 1974, **12**, 1218.

Table 1 Isolation of β -phenethylamine alkaloids

Species	Alkaloid	Ref.
<i>Alangium lamarckii</i>	N-Benzoylphenylalaninol	31
<i>Alhagi pseudalhagi</i>	3,4-Dihydroxyphenethyltrimethylammonium hydroxide, Hordenine, 3-Methoxy-4-hydroxyphenethyltrimethyl ammonium hydroxide, N-Methylmescaline, N-Methyltyramine, N-Methyl- β -phenethylamine, β -Phenethylamine	25
<i>Desmodium cephalotes</i> ^a	Candicine, Hordenine, β -Phenethylamine, Tyramine	
<i>Ephedra gerardiana</i> , <i>E. intermedia</i> ^b	Ephedrine, Pseudoephedrine	34
<i>E. gerardiana</i> var. <i>sikkimensis</i> , <i>E. intermedia</i> , ^c <i>E. nebrodensis</i> var. <i>procera</i> ,	Ephedrine, N-Methylephedrine, Pseudoephedrine	
<i>Ephedra</i> sp.		34
<i>Gymnocactus</i> <i>aguirreanus</i> , <i>G. beguinii</i> , <i>G. roseanus</i> , <i>G. roseanus</i> var.?	Hordenine, N-Methyl- β -phenethylamine, N-Methyltyramine	
<i>G. horripilus</i> ,	Hordenine, N-Methyl- β -phenethylamine	36
<i>G. knuthianus</i> , <i>G. viereckii</i>	N-Methyl- β -phenethylamine	36
<i>G. mandragora</i>	N-Methyl- β -phenethylamine, N-Methyltyramine	36
<i>Hygrocybe conica</i>	L-Dopa, Muscaflavin	39
<i>H. ovina</i>	L-Dopa	39
<i>Hygrocybe</i> spp.	Muscaflavin	40
<i>Lotus tetragonolobus</i> ^d	L-Dopa	41
<i>Magnolia denudata</i> , <i>M. liliiflora</i> , <i>M. obovata</i> , <i>M. kobus</i> , <i>M. grandiflora</i>	Tyramine	29
<i>Opuntia clavata</i>	N-Methyltyramine	
<i>Pleiospermium alatum</i>	N-Benzoyltyramine methyl ether N-Homoveratroylhomoveratrylamine N-4-Methoxystyrylbenzamide (alatamide)	31 30 31
<i>Polyporus berkeleyi</i> , <i>P. montanus</i>	Hordenine	37
<i>Sida cordifolia</i>	Ephedrine, β -Phenethylamine, Pseudoephedrine	33

Table 1—cont.

Species	Alkaloid	Ref.
<i>Strobilomyces floccopus</i>	L-Dopa	38
<i>Zanthoxylum americanum</i> , <i>Z. avicennae</i> , <i>Z. clava-herculis</i>	Candicine	27
<i>Vicia faba</i> ^d	L-Dopa	41

^a Unidentified quaternary bases also detected; ^b Collected in one area; ^c Collected in three areas; ^d Other species affording L-dopa were *Anagyris foetida*, *Astragalus baeticus*, *Calicotome villosa*, *Cercis siliquastrum*, *Cicer arietinum*, *Coronilla scorpioides*, *Lathyrus aphaca*, *L. cicera*, *L. ochirus*, *L. odoratus*, *Lens culinaris*, *Medicago hispida*, *M. sativa*, *Pisum sativum*, *Robinia pseudacacia*, *Scorpiurus muricata*, *Spartium junceum*, *Trifolium cherleri*, *Varieta vulgaris*, *Vicia altissima*, *V. bithynica*, *V. hybrida*, *V. peregrina*, *V. sativa*, *Wistaria floribunda*.

amines, viz. β -phenethylamine, ephedrine, and pseudoephedrine.³³ A g.l.c. technique for analysing *Ephedra* alkaloids has been used to evaluate the alkaloid content of a number of *Ephedra* species. Ephedrine and pseudoephedrine only were found in *E. intermedia* collected in one area and in *E. gerardiana*. Specimens of *E. intermedia* collected in other areas contained *N*-methylephedrine in addition, as did *E. gerardiana* var. *sikkimensis*, *E. nebrodensis* var. *procera*, an unidentified *Ephedra* sp., and various commercial samples of the drug Ma-Huang.³⁴ The cactus *Opuntia clavata* has been shown to contain *N*-methyltyramine.³⁵ Whereas no alkaloids could be detected in a number of *Thelocactus* spp., seven cacti of the genus *Gymnocactus* were found to contain various amounts of *N*-methyl- β -phenethylamine, in some cases accompanied by hordenine and *N*-methyltyramine.³⁶ *G. aguirreanus*, *G. roseanus*, and an unspecified variety of *G. roseanus* were particularly notable for their rich hordenine content. Hordenine has also been isolated for the first time from fungi, namely *Polyporus berkleyi* and *P. montanus*. *N*-Methyltyramine and tyramine were also detected.³⁷ Carpophores of three Basidiomycetes fungi, namely *Strobilomyces floccopus*,³⁸ *Hygrophorus conica*, and *H. ovina*, have been found to contain L-dopa.³⁹ In the last case this is significant in view of the co-occurrence of muscaflavin (1), which has been proposed to arise from

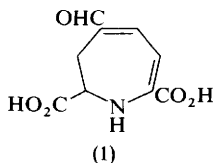

L-dopa by a sequence involving ring fission and recyclization. Muscaflavin also occurs in other *Hygrophorus* spp.⁴⁰ An efficient extraction of L-dopa from 26

³³ S. Ghosal, R. Ballav, P. S. Chauhan, and R. Mehta, *Phytochemistry*, 1975, **14**, 830.

³⁴ K. Yamasaki, K. Fujita, M. Sakamoto, K. Okada, M. Yoshida, and O. Tanaka, *Chem. and Pharm. Bull. (Japan)*, 1974, **22**, 2898.

³⁵ R. L. Vanderveen, L. G. West, and J. L. McLaughlin, *Phytochemistry*, 1974, **13**, 866.

³⁶ L. G. West, R. L. Vanderveen, and J. L. McLaughlin, *Phytochemistry*, 1974, **13**, 665.

³⁷ L. G. West, I. T. Johnson, and J. L. McLaughlin, *Lloydia*, 1974, **37**, 633.

³⁸ W. Steglich and F. Esser, *Phytochemistry*, 1973, **12**, 1817.

³⁹ W. Steglich and R. Preuss, *Phytochemistry*, 1975, **14**, 1119.

⁴⁰ R. von Ardenne, R. Dopp, H. Musso, and W. Steglich, *Z. Naturforsch.*, 1974, **29c**, 637.

leguminous plants has been recorded. *Vicia faba* and *Lotus tetragonolobus* had the highest concentrations.⁴¹

Methods of biological, chemical, and fluorometric assay of catecholamines have been reviewed.⁴² Another review dealing with radioimmunoassay of drugs includes amphetamines.⁴³ Numerous analytical methods and modifications have been applied to various types of phenethylamine, and these are summarized in Table 2. A convenient derivative of phenylalanine for g.l.c. determination is 2-trifluoromethyl-4-benzyl-3-oxazolin-5-one, obtainable by one-step reaction with trifluoroacetic anhydride.⁴⁴ Fluorescamine (2), a new fluorogenic reagent for amines,⁴⁵ has been used in conjunction with t.l.c. for the fluorometric determination of catecholamines⁴⁵ and amphetamines.⁴⁶ The fluorophores obtained in this way from catecholamines

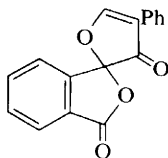

(2)

have also been efficiently separated by high-speed liquid chromatography.⁴⁷ Glyoxylic acid reacts with catecholamines and related primary phenethylamines to give strongly fluorescent compounds shown to be 2-carboxymethyl-3,4-dihydroisoquinolinium derivatives.⁴⁸ An ingenious and sensitive radiochemical method of assaying epinephrine and norepinephrine is to convert them into *O*-methyl analogues in the presence of catechol-*O*-methyl transferase and methyl-labelled *S*-adenosylmethionine. Oxidation then gives vanillin, which is counted.^{49,50} The rapid growth of interest in gas chromatography coupled with multiple ion detection (mass fragmentography)⁵¹ as a highly sensitive and specific means of quantitative assay is reflected in applications to analysis of dopamine⁵²⁻⁵⁵ and catecholamines.^{52,53,56,57}

⁴¹ E. Farina, P. Piu, and L. Strinna, *Boll. Soc. Ital. Biol. Sper.*, 1974, **50**, 508.

⁴² J. Savory in 'Lab. Diagn. Endocr. Dis. Proc. Appl. Semin. 1969', ed. F. W. Sunderman and F. W. Sunderman jun., Warren H. Green, St. Louis, 1971, p. 428 (*Chem. Abs.*, 1975, **82**, 94 881).

⁴³ S. J. Mule, E. Whitlock, and O. Jukofsky, *Clinical Chem. (Winston-Salem, N.C.)*, 1975, **21**, 81 (*Chem. Abs.*, 1975, **82**, 106 101).

⁴⁴ O. Grahl-Nielsen and B. Moevik, *Biochem Med.*, 1975, **12**, 143.

⁴⁵ M. Wiegele, S. L. De Bernardo, J. P. Teng, and W. Leimgruber, *J. Amer. Chem. Soc.*, 1972, **94**, 5927.

⁴⁶ J. Sherma, M. F. Dobbins, and J. C. Touchstone, *J. Chromatog. Sci.*, 1974, **12**, 300.

⁴⁷ K. Imai, *J. Chromatog.*, 1975, **105**, 135.

⁴⁸ O. Lindvall, A. Bjorklund, and L. A. Svensson, *Histochemistry*, 1974, **39**, 197.

⁴⁹ P. G. Passon and J. D. Peuler, *Analyt. Biochem.*, 1973, **51**, 618.

⁵⁰ P. E. Cryer, J. V. Santiago, and S. Shah, *J. Clin. Endocrin. Metab.*, 1974, **39**, 1025 (*Chem. Abs.*, 1975, **82**, 121 188).

⁵¹ R. A. W. Johnstone and F. A. Mellon, *Ann Reports (B)*, 1973, **70**, 16.

⁵² S. H. Koslow, *Biochem. Pharmacol.*, 1974 (Suppl. Pt. 2) 901, (*Chem. Abs.*, 1974, **81**, 147 945).

⁵³ S. H. Koslow, 'Front. Catecholamine Res. Proc. Int. Catecholamine Symp. 3rd, 1973', ed. E. Usdin, Pergamon, New York, 1973, 1085 (*Chem. Abs.*, 1974, **81**, 147 856).

⁵⁴ H. Ko, R. A. Lahti, D. J. Duchamp, and M. E. Royer, *Analyt. Letters*, 1974, **7**, 243.

⁵⁵ J. Seigfried, *J. Chromatog.*, 1974, **99**, 529.

⁵⁶ J. C. Lhuguenot and B. F. Maume, 'Mass Spectrom. Biochem. Med. Symp. 1973', ed. A. Frigerio, Raven, New York, 1974, p. 111.

⁵⁷ J. C. Lhuguenot and B. F. Maume, *J. Chromatog. Sci.*, 1974, **12**, 411.

Table 2 Analysis of β -phenethylamines

Substances Analysed	Method	Reagent or derivative
A	fluorometry g.l.c. t.l.c., g.l.c., and spectroscopy	fluorescamine ⁴⁶ TFA, ^{a-c} oxidation to oxime ^{d,e}
C	colorimetry fluorometry g.l.c. g.l.c., mass fragmentography liquid chromatography radiochemical spectrophotometry	thiosemicarbazide-alkali ^f dansyl, ^g fluorescamine, ⁴⁵ glyoxylic acid, ⁴⁸ K ₃ Fe(CN) ₆ , ^{h-i} trihydroxyindole ^k BSA-TFA, ^l TFA. ^c pentafluorobenzylimine-TMS, ^{56,57} perfluoropropionyl, ^{52,53} fluorescamine ⁴⁷ enzymic catechol O-methylation ^{49,50} iodine ^m
D	colorimetry fluorometry g.l.c., t.l.c. g.c.-m.s., mass fragmentography liquid chromatography	2,4,6-trinitrobenzenesulphonic acid ⁿ dansyl, ^g fluorescamine, ⁴⁵ K ₃ Fe(CN) ₆ , ^{i,o} TFA ^p PFP, ⁵²⁻⁵⁴ TFA ⁵⁵ fluorescamine ⁴⁷
dopa	fluorometry	K ₃ Fe(CN) ₆ ^j
HD	g.c.-m.s., mass fragmentography	TFA ⁵⁵
MT	fluorometry g.l.c.	K ₃ Fe(CN) ₆ ^q TFA ^r
PA	g.l.c.	TFA ⁴⁴
T	g.l.c. t.l.c., high-resolution m.s.	TFA ^s dansyl ^t

A = amphetamines, C = catecholamines, D = dopamine, HD = 6-hydroxydopamine, MT = 3-methoxytyramine, PA = phenylalanine, T = tyramine; ^a M. Sugijura, K. Hiraga, and T. Nakao, *Jikeikai Med. J.*, 1974, **20**, 23 (*Chem. Abs.*, 1974, **81**, 33 085); ^b N. C. Jain, T. C. Sneath, and R. D. Budd, *Clinical Chem. (Winston-Salem, N.C.)*, 1974, **20**, 1460 (*Chem. Abs.*, 1975, **82**, 92 835); ^c H. Kaneshima and M. Mori, *Hokkaidoritsu Eisei Kenkyushoho*, 1972, 32 (*Chem. Abs.*, 1974, **81**, 39); ^d A. H. Beckett and K. K. Midha, *Xenobiotica*, 1974, **4**, 297; ^e K. Baily, H. O. Beckstead, D. Legault, and D. Verner, *J. Assoc. Offic. Analyt. Chemists*, 1974, **57**, 1134 (*Chem. Abs.*, 1975, **82**, 21 852); ^f R. B. Salama and S. K. W. Khalil, *J. Pharm. Sci.*, 1974, **63**, 1301; ^g A. O. Chilingarov and P. A. Kometiani, *Voprosy Med. Khim.*, 1974, **20**, 31 (*Chem. Abs.*, 1974, **81**, 46 971); ^h G. Schwedt, *Clinica Chim. Acta*, 1974, **57**, 247; ⁱ V. I. Okladnikov, V. V. Malyshev, and L. K. Shatunova, *Nauch. Tr. Irkutsk. Gosud. Med. Inst.*, 1971, No. 112, p. 161 (*Chem. Abs.*, 1974, **81**, 958); ^j G. Schwedt, *Clinica Chim. Acta*, 1974, **57**, 291; ^k H. Saito and I. Shudo, *Yakugaku Zasshi*, 1972, **68**, 422 (*Chem. Abs.*, 1974, **81**, 114 324); ^l H. G. Lovelady and L. L. Foster, *J. Chromatog.*, 1975, **108**, 43; ^m A. M. Taha, A. K. S. Ahmad, C. S. Gomaa, and H. M. El-Fatary, *J. Pharm. Sci.*, 1974, **63**, 1853; ⁿ A. Charteris and R. John, *Analyt. Biochem.*, 1975, **66**, 365; ^o S. R. Snyder, *J. Neurol. Transm.*, 1974, **35**, 87 (*Chem. Abs.*, 1975, **82**, 13 291); ^p B. I. Keda and E. B. Vinnitskaya, *Lab. Delo.*, 1974, 342 (*Chem. Abs.*, 1974, **81**, 132 376); ^q W. Kehr, *Naunyn-Schmiedeberg's Arch. Pharmacol.*, 1974, **284**, 149 (*Chem. Abs.*, 1974, **81**, 165 758); ^r M.-T. Wang, K. Imai, M. Yoshioka, and Z. Tamura, *Chem. and Pharm. Bull. (Japan)*, 1974, **22**, 970; ^s E. R. Kaplan, N. Sapeika, and I. M. Moodie, *Analyst.*, 1974, **99**, 565; ^t S. R. Phillips, D. A. Durden, and A. A. Boulton, *Canad. J. Biochem.*, 1974, **52**, 366.

An updated section on aryl derivatives of amino-alcohols is included in the latest volume of Rodd.⁵⁸ A review of the chemistry and pharmacology of the drug 'Khat' (*Catha edulis*), whose main active constituent is (+)-nor-pseudoephedrine, includes

⁵⁸ A. B. Turner, in Rodd's 'Chemistry of Carbon Compounds', 2nd edn., III E, ed. S. Coffey, Elsevier, Amsterdam, 1974, p. 79.

Quantum mechanical calculations on the conformational properties of norepinephrine have also been reported.⁶⁵ Interconversion of ephedrine and pseudo-ephedrine to a slight extent under γ -irradiation has been observed.⁶⁶ Absorption of carbon dioxide by cupric ephedrinates can be accounted for by carbamate formation rather than formation of metal-carbon dioxide bonds.⁶⁷ Acylation of β -phenethylamines by protected amino-acids, e.g. *N*-CBZ-leucine, has been reported.⁶⁸

Methods of synthesizing dopa have been reviewed.⁶⁹ The biological properties of 3-hydroxymethyl analogues prepared from tyrosine⁷⁰ and from *L*-dopa and *DL*- α -methyldopa⁷¹ have been investigated. Syntheses *via* 4-hydroxy-3-methoxyphenacyl chloride of the 4-*O*-methyl ether of epinephrine and related catecholamines have been described.⁷² Chlorinated analogues of isoproterenol have been prepared and tested as muscle relaxants.⁷³ A test of ability to induce hypothermia in rabbits has been used as a screen for psychotomimetic activity in numerous phenethylamines, and conclusions have been drawn about structure-activity relationships.⁷⁴ 2-Hydroxy-4,5-dimethoxyphenethanolamine and its methylenedioxy-analogue are synthetic psychotomimetics which may be endogenous in schizophrenics.⁷⁵ Investigation of a confiscated drug showed it to be 3-methoxy-4-methylamphetamine, a new potent hallucinogen.⁷⁶

3 Simple Isoquinoline Alkaloids

Alkaloid isolations and structural elucidations are summarized in Table 3. Four members of the naphthalene isoquinoline group of alkaloids have now been isolated from *Ancistrocladus heyneanus*⁷⁷ (*cf.* Vols. 2-5). Two new alkaloids of this type, ancistrocladonine (14) and ancistroealaensine (15), have been isolated from the roots of *A. ealaensis*.⁷⁸ The absolute stereochemistries of ancistrocladine (11; $R^1 = R^2 = H$) and ancistrocladinine (12) have now been determined.⁷⁹ X-Ray crystallography served to confirm the relative configuration of the two methyl groups at C-1 and C-3, assigned on n.m.r. evidence, and also to establish the relative stereochemistry with respect to the general plane of the isoquinoline ring of the

⁶⁵ B. S. Zhorov and V. A. Govyrin, *Doklady Akad. Nauk. S.S.S.R.*, 1974, **215**, 986 (*Chem. Abs.*, 1974, **81**, 59 704).

⁶⁶ Kh. P. Ibragimov, Kh. R. Rustamov, and O. A. Abrarov, *Uzbek. khim. Zhur.*, 1974, **18**, 23 (*Chem. Abs.*, 1974, **81**, 63 271).

⁶⁷ M. T. Beck and F. Joo, *J.C.S. Chem. Comm.*, 1975, 230.

⁶⁸ I. D. Kiseleva, N. S. Volodarskaya, D. M. Maslin, Yu. A. Davidovitch, S. V. Rogozhin, and V. G. Yashunsky, *Izvest. Akad. Nauk. S.S.S.R., Ser. khim.*, 1975, 424.

⁶⁹ K. Toi, 'Synthetic Production and Utilization of Amino Acids', ed. T. Kaneko, Y. Izumi, and I. Chibata, Kodansha, Tokyo, 1974, p. 89 (*Chem. Abs.*, 1975, **82**, 140 474).

⁷⁰ T. S. T. Wang and J. A. Vida, *J. Medicin. Chem.*, 1974, **17**, 1120.

⁷¹ M. Atkinson, D. Hartley, L. H. C. Lunts, and A. C. Ritchie, *J. Medicin. Chem.*, 1974, **17**, 249.

⁷² E. A. Nodiff, J. M. Hulsizer, and K. Tanabe, *Chem. and Ind.*, 1974, 962.

⁷³ C. Kaiser, D. F. Colella, A. M. Pavloff, and J. R. Wardell jun., *J. Medicin. Chem.*, 1974, **17**, 1071.

⁷⁴ F. A. B. Aldous, B. C. Barass, K. Brewster, D. A. Buxton, D. M. Green, R. M. Pinder, P. Rich, M. Skeils, and K. J. Tutt, *J. Medicin. Chem.*, 1974, **17**, 1100.

⁷⁵ G. J. Kapadia, B. K. Chowdhury, S. G. Rao, and S. N. Pradhan, *J. Pharm. Sci.*, 1974, **63**, 1339.

⁷⁶ C. de Zorzi and A. Cavalli, *Zacchia*, 1974, **10**, 58 (*Chem. Abs.*, 1975, **82**, 786).

⁷⁷ S. C. Sharma, Y. N. Shukla, and J. S. Tandon, *Phytochemistry*, 1975, **14**, 578.

⁷⁸ J. P. Foucher, J. L. Poussot, A. Cavé, and A. Cavé, *Phytochemistry*, 1974, **13**, 1253.

⁷⁹ T. R. Govindachari, K. Nagarajan, P. C. Parthasarathy, T. G. Rajagoplan, H. K. Desai, G. Kartha, S.-M. L. Chen, and K. Nakanishi, *J.C.S. Perkin I*, 1974, 1413.

Table 3 Isolation of isoquinoline alkaloids

Source	Alkaloid	Ref.
<i>Ancistrocladus ealaensis</i>	Ancistrocladonine (14), Ancistroealaensine (15)	} 78
<i>A. heyeanus</i>	Ancistrocladidine, Ancistrocladine (11), Ancistrocladinine (12), Ancistrocladisine	
<i>Alhagi pseudalhagi</i>	Salsolidine	25
<i>Berberis baluchistanica</i>	Corydaldine (20; $R^1 = R^2 = \text{Me}$; $R^3 = \text{H}$)	85
<i>Cryptostylis erythroglossa</i>	Cryptostyline I, Cryptostyline II, Cryptostyline III, 1-(3,4-Methylenedioxyphenyl)- 6,7-dimethoxy-2-methyl-3,4- dihydro-isoquinolinium iodide (17) 1-(3,4-Methylenedioxyphenyl)- 6,7-dimethoxy-2-methyl isoquinolinium chloride (18)	} 82
<i>Desmodium cephalotes</i> ^a	Salsolidine	
<i>Doryphora sassafras</i>	Corypalline (21; $R = \text{H}$), Doryanine (20; $R^1 + R^2 = \text{CH}_2$; $R^3 = \text{Me}$), Doryphornine (20; $R^1 = R^3 = \text{Me}$; $R^2 = \text{H}$)	} 86
<i>Lophocereus schottii</i>	Pilocereine, Lophocereine	
<i>L. schottii</i> forma <i>monstruosus</i>		
<i>L. schottii</i> forma <i>mieckleyanus</i>		
<i>Xanthoxylum arnottianum</i>	Unspecified <i>NN</i> -dimethyl tetrahydroisoquinolinium salt	83
<i>Ziziphium amphibia</i>	Amphibine (19)	84

^a Unidentified quaternary bases also present.

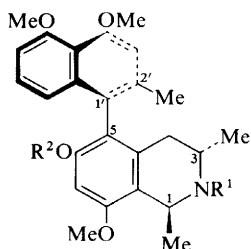

(11)

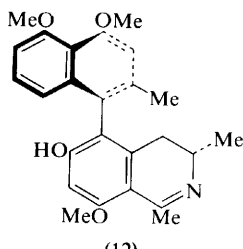

(12)

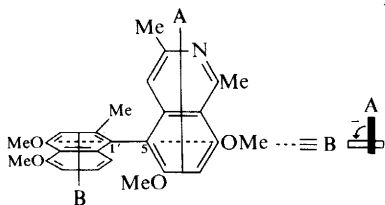

(13)

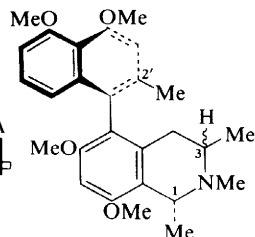

(14)

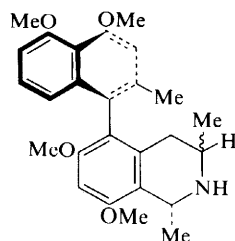

(15)

methyl groups at C-2' and C-1. The isoquinoline (13) derived from *O*-methylancistrocladine (11; $R^1 = H$; $R^2 = Me$) by degradation showed a negative first extremum ($\Delta\epsilon_{245}$ is -91.0) in its exciton split c.d. spectrum, in keeping with negative chirality of the long axes as shown in (13). The 3*S* configuration in ancistrocladine follows, and was confirmed by ozonolysis in 10% aqueous formic acid to give (+)-*L*- β -amino-*n*-butyric acid.⁷⁹

The methines obtained by Hofmann degradation of ancistrocladonine and the *N*-methyl derivative of ancistroealaensine were identical. Reduction gave an *n*-propyl derivative (16) which differed in properties from the compound of the same gross structure obtained from ancistrocladine (11; $R^1 = R^2 = H$), implying a difference from ancistrocladine in stereochemistry at the benzylic centre relative to the

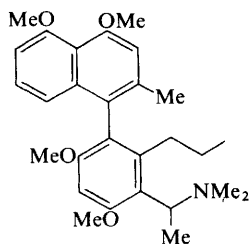

(16)

biaryl configuration. Also, *N*-methylancistroealaensine was spectroscopically identical to ancistrocladonine but differed from it in optical rotation (as it happens, only in sign). The stereochemistry of the new alkaloids was not formulated but the published data appear to be consistent with the relative stereochemistry shown in (14) and (15) for ancistrocladonine and ancistroealaensine, respectively. Salsolidine has been obtained from the roots and leaves of *Desmodium cephalotes*.²⁶ Two previously uninvestigated forms of the cactus *Lophocereus schottii*, (namely, formae *monstrous* and *mieckleyanus*) were found to contain pilocereine and lophocereine, with other alkaloids present only in traces.⁸⁰ A review dealing with the alkaloids of the Orchidaceae has appeared.⁸¹ One species, *Cryptostylis erythroglossa*, has afforded two new alkaloids, the dehydro-salts (17) and (18) of cryptostyline I, together with the known alkaloids (–)-cryptostyline I, II, and III.⁸² An alkaloid isolated from *Xanthoxylum arnottianum* as its picrate $C_{11}H_{16}O_2N^+ C_6H_2O_7N_3^-$ was assumed to be

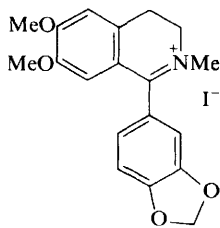

(17)

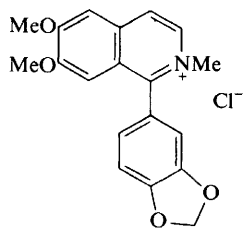

(18)

⁸⁰ L. G. West, J. L. McLaughlin, and W. H. Earle, *Phytochemistry*, 1975, **14**, 291.

⁸¹ I. Granelli, *Chem. Comm., Univ. Stockholm*, 1974, No. 6 (*Chem. Abs.*, 1974, **81**, 78 118).

⁸² S. A. Agurell, I. Granelli, K. Leander, B. Luning, and J. Rosenblom, *Acta Chem. Scand. (B)*, 1974, **28**, 239.

a simple *NN*-dimethylisoquinolinium derivative. The m.p. of the picrate, however, differed from that of 6,7-dihydroxy- or of 7,8-dihydroxy-isoquinolinium picrates.⁸³ The novel tetrahydroisoquinoline amphibine (19) may be regarded as a modified tetrapeptide. It has been isolated from *Ziziphus amphibia*, from which only cyclopeptide alkaloids had previously been isolated.⁸⁴ The isoquinolone alkaloids

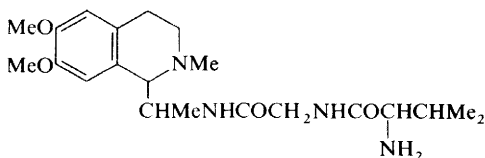

(19)

corydaldine (20; $R^1 = R^2 = \text{Me}$; $R^3 = \text{H}$), isolated from *Berberis baluchistanica*, could be a degraded benzyloisoquinoline in view of its co-occurrence with the oxidatively degraded bis-benzyloisoquinoline alkaloid baluchistanamine (*cf.* Section 17).⁸⁵ Two isoquinolones, doryanine (20; $R^1 + R^2 = \text{CH}_2$; $R^3 = \text{Me}$) and the new alkaloid doryphornine (20; $R^1 = R^3 = \text{Me}$; $R^2 = \text{H}$), have been isolated from *Doryphora sassafras* together with the tetrahydroisoquinoline alkaloid corypalline (21; $R = \text{H}$)

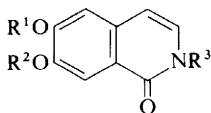

(20)

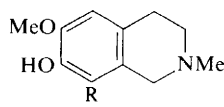

(21)

and other alkaloids, including aporphines and a new alkaloid doryflavine.⁸⁶ The structure of the latter was not fully established, but the alkaloid was believed to be related to the aristolactams, a group of alkaloids which appear to be derived from aporphines by oxidative elision of a carbon atom⁸⁷ (*cf.* Chapter 9). During studies on the synthesis of cularine, the isoquinolone (22) was synthesized in modest yield from the bromoindanone (23).⁸⁸ Corydaldine and *N*-methylcorydaldine were also prepared by conventional methods.

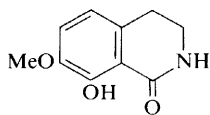

(22)

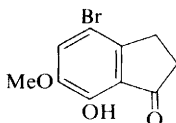

(23)

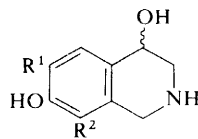

(24)

6-Hydroxy-7-methoxy-*N*-methyltetrahydroisoquinolines react rapidly with lead tetra-acetate to give moderate yields of the corresponding 4-acetoxy derivatives.⁸⁹

⁸³ H. Ishii, K. Hosoya, T. Ishikawa, E. Ueda, and J. Haginawa, *Yakagaku Zasshi*, 1974, **94**, 322 (*Chem. Abs.*, 1974, **81**, 132 753).

⁸⁴ R. Tschesche, C. Spiltes, and G. Eckhardt, *Chem. Ber.*, 1974, **107**, 1329.

⁸⁵ M. Shamma, J. E. Foy, and G. A. Miana, *J. Amer. Chem. Soc.*, 1974, **96**, 7809.

⁸⁶ C. R. Chen, J. L. Beal, R. W. Doskotch, L. A. Mitscher, and G. H. Svobda, *Lloydia*, 1974, **37**, 493.

⁸⁷ M. Akasu, H. Hokawa, and M. Fujita, *Tetrahedron Letters*, 1974, 3609.

⁸⁸ A. H. Jackson, G. W. Stewart, G. A. Charnock, and J. A. Martin, *J.C.S. Perkin I*, 1974, 1911.

⁸⁹ O. Hoshino, K. Ohjama, M. Taga, and B. Umezawa, *Chem. and Pharm. Bull. (Japan)*, 1974, **22**, 2587.

7-Hydroxy compounds like corypalline (21; R = H), on the other hand, react with this reagent to give quinol acetates, and the product from corypalline was found to react readily with concentrated aqueous hydrogen halides to give 8-halogenocorypallines (21; R = Cl, Br, or I).⁹⁰ The Bobbitt modification of the Pomeranz-Fritsch cyclization has been used to prepare the 4-hydroxyisoquinolines (24; R¹ = H; R² = OH) and (24; R¹ = R² = OH).⁹¹ The new modification of this cyclization (the one proceeding *via* the *N*-tosylate) has provided an efficient synthesis of a number of simple isoquinolines with oxygenation in ring A.⁹² Syntheses of corgoine (*cf.* Vol. 5) have been published.^{93,94}

Intramolecular nitrile-aldehyde condensations lead to the formation of 3-chloroisoquinolines, *e.g.* (25), following Vilsmeier reaction of aryl acetonitriles.⁹⁵ The corresponding isoquinolines carrying an extra formyl group at C-4 are also obtained to various extents, and in the case of 3,4-dimethoxyphenylacetonitrile, (26) is the only product. Since formylation of (25) occurs at the 5-position, it is considered that the 4-formyl analogues arise through formylation α to the nitrile function before isoquinoline formation. A series of 1-aryl-3-oxo-1,2,3,4-tetrahydroisoquinolines, *e.g.* (28), have been prepared by intermolecular condensation of an arylaldehyde and a phenylacetonitrile using PPA, the bis-carboxamides (27) being intermediates.⁹⁶ 3,4-Dihydroxy-1-phenyl-tetrahydroisoquinoline and its *N*-methyl analogue have also been obtained by the Pictet-Spengler route.⁹¹ Facile synthesis of 1-amino-3-arylisoquinolines has been achieved by the condensation (catalysed by lithium dimethylamide) of *o*-tolunitrile with itself or with other nitriles, *e.g.* benzonitrile and β -naphthonitrile, the latter giving (29).⁹⁷

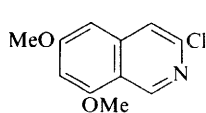

(25)

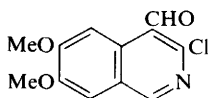

(26)

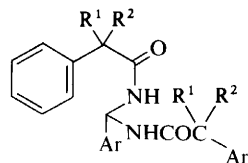

(27)

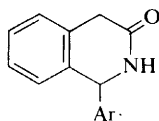

(28)

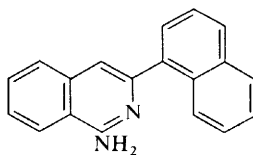

(29)

⁹⁰ H. Itara, O. Hoshino, and B. Umezawa, *Heterocycles*, 1975, 3, 123.

⁹¹ R. Sarges, *J. Heterocyclic Chem.*, 1974, 11, 599.

⁹² A. J. Birch, A. H. Jackson, and P. V. R. Shannon, *J.C.S. Perkin I*, 1974, 2185.

⁹³ H. Sugura and B. R. Pai, *Indian J. Chem.*, 1974, 12, 1141.

⁹⁴ T. Kametani, K. Takahashi, and C. V. Loc, *Tetrahedron*, 1975, 31, 235.

⁹⁵ T. Koyama, T. Hirota, Y. Shinohara, M. Yamato, and S. Ohmori, *Chem. and Pharm. Bull. (Japan)*, 1975, 23, 497.

⁹⁶ G. Deak, K. Gall-Istok, L. Hazai, and L. Sterk, *Synthesis*, 1975, 393.

⁹⁷ E. M. Kaiser, J. D. Petty, L. E. Solter, and W. R. Thomas, *Synthesis*, 1974, 805.

A variety of spiro-tetrahydroisoquinoline-piperidines have been synthesized by established routes. The compounds and methods include (30) by a Pictet-Spengler-type reaction, (31) by cyclization of an *N*-3,4-dimethoxybenzylglycine nitrile derivative, and (32) *via* Schmidt rearrangement of a 3-spiro-indan-1-one derivative.⁹⁸

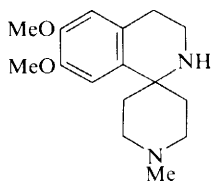

(30)

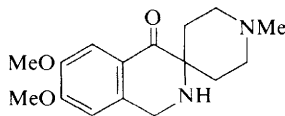

(31)

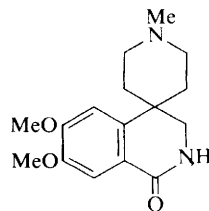

(32)

4-Oxygenated isoquinolinium derivatives (34) have been prepared by isomerization of dihydroindeno-azirines (33).⁹⁹ Studies are reported on the Birch reduction of 1,2,3,4-tetrahydro-2-methylisoquinoline and its 6- and 7-methoxy-analogues.¹⁰⁰

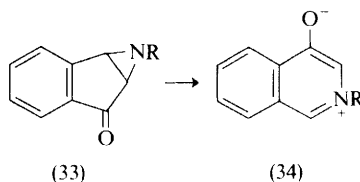

(33)

(34)

The condensation of L-dopa and L-tryptamine with acetaldehyde in mammalian systems has been surveyed and a number of the possible compounds formed have been synthesized.¹⁰¹ The similar reaction of catecholamines has also been reviewed.¹⁰² It has been demonstrated that the optically active tetrahydroisoquinolines salsolinol, salsoline, and isosalsoline and their antipodes can be prepared by enzyme-catalysed condensation of dopa or appropriate derivatives with acetaldehyde.¹⁰³ The *cis* (1*S*, 3*S*) acid (35; R = H), formed as the major component from L-dopa and acetaldehyde under acid catalysis (*cf.* Vol. 4) and previously isolated from velvet beans (*cf.* Vol. 3), has now been isolated from blackened sake cake.¹⁰⁴ 3-Carboxytetrahydroisoquinolines of this type have also been synthesized from dopa derivatives by phenolic cyclization.¹⁰⁵ Esters of the acid (35; R = H) and its ethers undergo base-catalysed equilibration to give predominantly the *trans* (1*S*, 3*R*) isomer. The antipodes behave analogously.¹⁰⁶ The reaction of dopamine hydrochloride with acetaldehyde at pH 4.5 has been reported to give not only

⁹⁸ D. Berney and T. Jauner, *Helv. Chim. Acta*, 1975, **58**, 74.

⁹⁹ P. E. Hansen and K. Undheim, *J.C.S. Perkin I*, 1975, 305.

¹⁰⁰ T. A. Crabb and J. R. Wilkinson, *J.C.S. Perkin I*, 1975, 58.

¹⁰¹ A. Brossi, *Heterocycles*, 1975, **3**, 343.

¹⁰² G. Cohen, *Biochem. Pharmacol.*, 1974, (Suppl. Part 2), p. 851.

¹⁰³ S. Teitel and A. Brossi, *Lloydia*, 1974, **37**, 196.

¹⁰⁴ T. Ohba, H. Kato, T. Kurata, and M. Fujimaki, *Agric. and Biol. Chem. (Japan)*, 1975, **39**, 139.

¹⁰⁵ T. Kametani, K. Kigasawa, M. Hiiragi, H. Ishimaru, and S. Itaga, *J. Heterocyclic Chem.*, 1974, **11**, 1063.

¹⁰⁶ H. Bruderer, A. Brossi, A. Focella, and S. Teitel, *Helv. Chim. Acta*, 1975, **58**, 795.

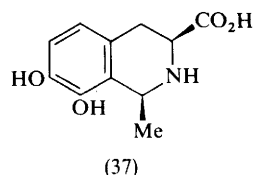
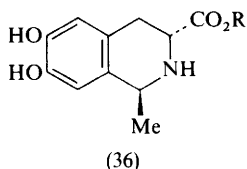
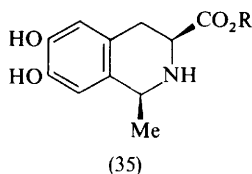

salsolinol (36) but also its 7,8-dioxygenated isomer, isosalsolinol (37).¹⁰⁷ Quantitative assay of salsolinol by mass fragmentography of the perfluoropropionyl derivative has been described.¹⁰⁸

Asymmetric syntheses of (*R*)-(+)- and (*S*)-(–)-salsolidines have been effected, using the Schiff base from homoveratraldehyde and (*R*)-(+)- or (*S*)-(–)- α -methylbenzylamines.¹⁰⁹ These were converted into *N*-substituted 3,4-dihydroisoquinolinium iodides, e.g. (38), borohydride reduction and subsequent hydrogenolysis of the α -methylbenzyl group then giving the optically active alkaloids. The synthesis has been reported of a number of *N*-substituted analogues [e.g. (39; R = CO₂Me)] of the fibrinolytic agent (39; R = H) in order to improve oral absorption properties and yet be able to form (39; R = H) *in vivo*.¹¹⁰ The *R-R* enantiomer of the bisquaternary salt (40) was found to be a more potent neuromuscular blocking agent than either the *S-S* enantiomer or the *meso*-compound.¹¹¹

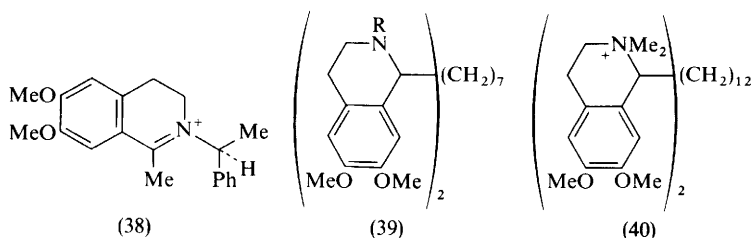

4 Benzylisoquinoline Alkaloids

Alkaloid isolation studies are summarized in Table 4. Reticuline has been isolated from *Anona reticulata*,¹¹² *Corydalis incisa*,¹¹³ *C. koidzumiana*,¹¹⁴ *Doryphora sassafras*,⁸⁶ and *Magnolia obovata*.¹¹⁵ The last species also contained magnocurarine.¹¹⁵ *N*-Methylcoclaurine has been isolated from *Glaucium fibrilligerum*¹¹⁶ and is among new isolations, together with armepavine and norarmepavine from *Retanilla*

¹⁰⁷ G. S. King, B. L. Goodwin, and M. Sandler, *J. Pharm. Pharmacol.*, 1974, **26**, 476.

¹⁰⁸ G. H. Draffan, R. A. Clara, B. L. Goodwin, C. R. J. Ruthven, and M. Sandler, *Adv. Mass Spectrometry*, 1974, **6**, 245.

¹⁰⁹ T. Okawara and T. Kametani, *Heterocycles*, 1974, **2**, 571.

¹¹⁰ R. L. Buchanan, V. Sprancmanis, T. A. Jenks, R. R. Crenshaw, and G. M. Luke, *J. Medicin. Chem.*, 1974, **17**, 1248.

¹¹¹ A. A. Genenah, T. O. Soine, and N. A. Shaath, *J. Pharm. Sci.*, 1975, **64**, 62.

¹¹² T.-H. Yang, C.-M. Chen, and H.-N. Kong, *Pei I. Hsueh Pao*, 1973, 130 (*Chem. Abs.*, 1974, **81**, 60 846).

¹¹³ G. Nonaka and I. Nishioka, *Phytochemistry*, 1974, **13**, 2620.

¹¹⁴ C. Tani, N. Nagakura, S. Hattori, and M.-T. Kao, *Yakugaku Zasshi*, 1974, **94**, 844 (*Chem. Abs.*, 1974, **81**, 166 363).

¹¹⁵ K. Ito and S. Asai, *Yakugaku Zasshi*, 1974, **94**, 729 (*Chem. Abs.* 1974, **81**, 166 344).

¹¹⁶ A. K. Yusunov and I. A. Israelov, *Khim. prirod. Soedinenii*, 1974, 538 (*Chem. Abs.*, 1975, **82**, 14 014).

Table 4 Isolation of benzylisoquinoline alkaloids

Source	Alkaloid	Ref.
<i>Anona reticulata</i> ^a	Reticuline	112
<i>Corydalis incisa</i>	Reticuline	113
<i>C. koidzumiana</i>	L-(+)-Reticuline	114
<i>Doryphora sassafras</i>	Reticuline	86
<i>Erythrina poeppigiana</i> , <i>E. glauca</i> , <i>E. variegata</i>	N-Nororientaline	120
<i>Eschscholtzia oregana</i>	Escholamine (41; R ¹ + R ² = CH ₂) Escholamidine (41; R ¹ = Me; R ² = H)	} 121
<i>Glaucium fibrilligerum</i>	N-Methylcoclaurine	
<i>Magnolia obovata</i>	Reticuline, Magnocurarine	} 115
<i>Papaver somniferum</i> stamens	Papaverine	
<i>Retanilla ephedra</i>	Armepavine, N-Methylcoclaurine, Norarmepavine	} 117
<i>Talguena quinquenervis</i>	Coclaurine	
<i>Zanthoxylum americanum</i>	Tembetarine	27
<i>Z. avicennae</i>	Tembetarine	28
<i>Zizyphus jujuba</i>	Coclaurine	119

^a Three aporphine alkaloids and traces of an unknown base were also obtained.

ephedra.¹¹⁷ Coclaurine itself has been isolated from *Talguena quinquenervis*,¹¹⁸ and was found along with peptide alkaloids in *Zizyphus jujuba*.¹¹⁹ N-Nororientaline was obtained from three species of *Erythrina* from Singapore, namely *E. poeppigiana*, *E. glauca*, and *E. variegata*.¹²⁰ *Eschscholtzia oregana* afforded a number of quaternary alkaloids, including two benzylisoquinolines, namely escholamine (41; R¹ + R² = CH₂) and the new alkaloid escholamidine inferred to have structure (41; R¹ = Me; R² = H).¹²¹ Tembetarine (reticuline metho-salt) was shown to be present in *Zanthoxylum americanum*²⁷ and *Z. avicennae*.²⁸

New syntheses have been reported of the free bases corresponding to escholamine (41; R¹ + R² = CH₂) and takatonine (42) by Reissert reaction of the appropriate

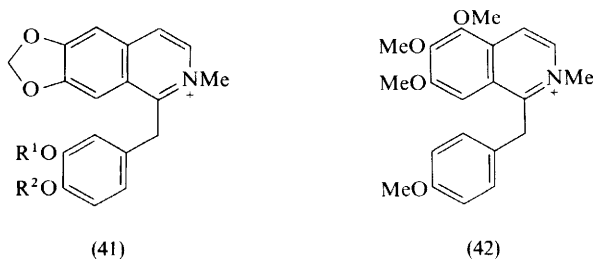

¹¹⁷ D. S. Bhakuni, C. Gonzalez, P. G. Sammes, and M. Silva, *Rev. Latinoamer. Quím.*, 1974, **5**, 158 (*Chem. Abs.*, 1975, **82**, 108 803).

¹¹⁸ R. Torres and E. Sanchez, *Anales Assoc. quím. argentina*, 1974, **62**, 361 (*Chem. Abs.*, 1975, **82**, 152 158).

¹¹⁹ H. Otsuka, Y. Ogihara, and S. Shibata, *Phytochemistry*, 1974, **13**, 2016.

¹²⁰ K. Ito, H. Haruna, and H. Furukawa, *Yakugaku Zasshi*, 1975, **95**, 358 (*Chem. Abs.*, 1975, **82**, 167 515).

¹²¹ J. Slavik, L. Slavikova, and L. Dolejs, *Coll. Czech. Chem. Comm.*, 1975, **40**, 1095.

isoquinolines.¹²² The latter were conveniently obtained by the new *N*-tosylamino-acetal synthesis.^{92,88} The alternative approach, wherein an alkoxybenzylmagnesium halide was added to an appropriate imino-acetal derivative prior to *N*-tosylation and dilute acid cyclization, was much less successful, as illustrated by the low-yield synthesis of (43; $R^1 + R^2 = \text{CH}_2$; $R^3 = \text{H}$; $R^4 = \text{Me}$). The main obstacle appeared to be the final detosylation step, which afforded only 4% of this imine, the main product (16%) being 6,7-methylenedioxyisoquinoline.⁸⁸ Condensation of 3,4-dihydroxyphenylpyruvate and dopamine to give high yields of the acid (44), and the

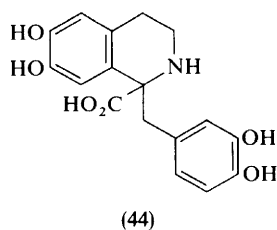
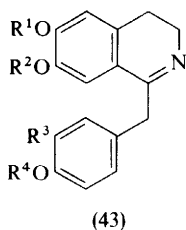

oxidative decarboxylation of this to 1,2-dehydronorlaudanosoline (43; $R^1 = R^2 = R^4 = \text{H}$; $R^3 = \text{OH}$) by chemical means, have been carried out under physiological conditions as part of a study of the early stages of benzylisoquinoline biosynthesis.¹²³ Details of the preparation of specifically ¹⁴C-labelled samples of papaverine and quinopavine have appeared.¹²⁴

The 1-benzyl-4-oxo-tetrahydroisoquinoline (46) has been synthesized by a route (Scheme 2) in which the nitrogen atom is introduced by a Leuckart reaction.¹²⁵ The reaction of the bromobenzylisoquinolines (47; $R^1 = R^3 = R^4 = \text{Me}$; $R^2 = \text{H}$) and (47; $R^1 = \text{Me}$; $R^2 = \text{H}$; $R^3 + R^4 = \text{CH}_2$) with methyl sulphinyl carbanion afforded the corresponding protostephanine analogues (49; $R^1 = R^3 = R^4 = \text{Me}$; $R^2 = \text{H}$) and (49; $R^1 = \text{Me}$; $R^2 = \text{H}$; $R^3 + R^4 = \text{CH}_2$), evidently by base-catalysed rearrangement of morphinandienone intermediates (48) followed by addition of the reagent. A

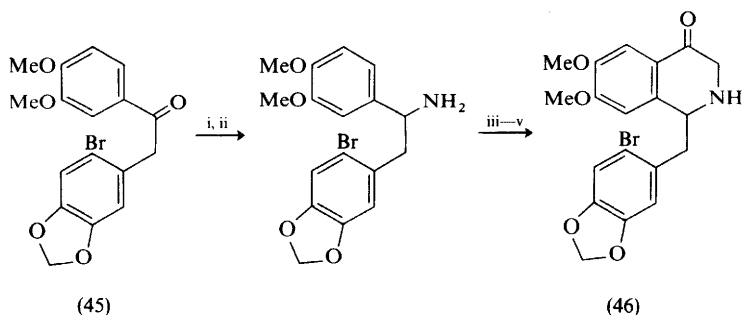

Reagents: i, HCONH_2 , HCO_2H ; ii, hydrolysis; iii, $\text{BrCH}_2\text{CO}_2\text{Et}$; iv, aq. NaOH ; v, POCl_3

Scheme 2

¹²² A. J. Birch, A. H. Jackson, and P. V. R. Shannon, *J.C.S. Perkin I*, 1974, 2190.

¹²³ M. L. Wilson and C. J. Coscia, *J. Amer. Chem. Soc.*, 1975, **97**, 431.

¹²⁴ S. D. Ithakissios, G. Tsatsas, J. Nikokavouras, and A. Tsolis, *J. Labelled Compounds*, 1974, **10**, 369.

¹²⁵ M. Srinivasan and J. B. Rampal, *Chem. and Ind.*, 1975, 89.

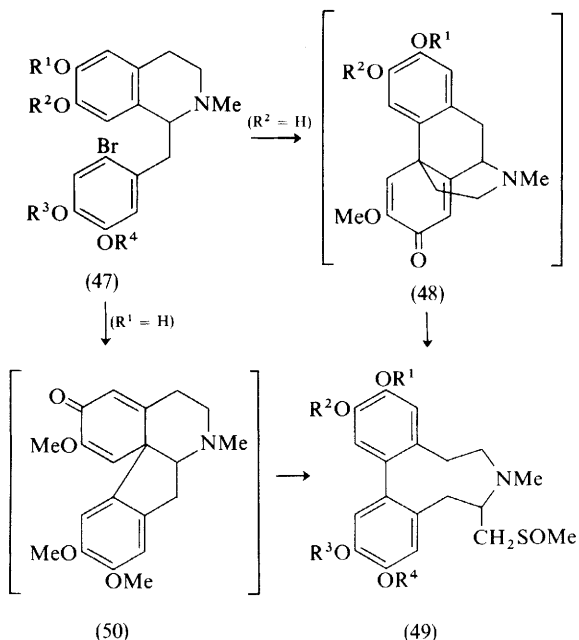

related product (49; $R^1 = H$; $R^2 = R^3 = R^4 = Me$) was obtained from the bromobenzisoquinoline (47; $R^1 = H$; $R^2 = R^3 = R^4 = Me$) with its free phenolic grouping at C-6, the diene (50) being the postulated intermediate in this case.¹²⁶ The ten-membered analogue of (49; $R^1 = H$; $R^2 = R^3 = R^4 = Me$) was prepared in similar fashion.

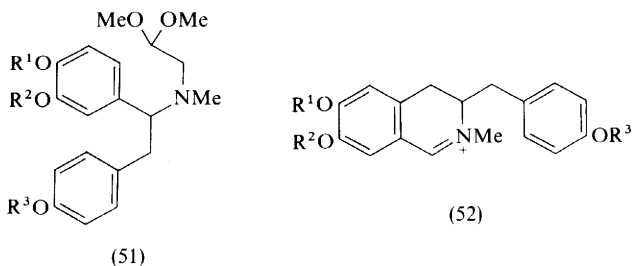

Treatment of optically active amino-acetals of the type (51) with acid leads directly to optically active 3-benzylisoquinolinium salts of the type (52), through rearrangement of intermediate 1-benzyl-1,2-dihydroisoquinolines.¹²⁷ This appears to involve a bimolecular exchange process, and the six-centre transition state (53) is favoured. A similar transition state (54) is postulated for the interaction of two molecules of opposite configuration. Both transition states appear to be involved when a mixture

¹²⁶ S. Kano, T. Ogawa, T. Yokomatsu, E. Komiyama, and S. Shibuya, *Tetrahedron Letters*, 1974, 1063.

¹²⁷ R. G. Kinsman, A. W. C. White, and S. F. Dyke, *Tetrahedron*, 1975, **31**, 449.

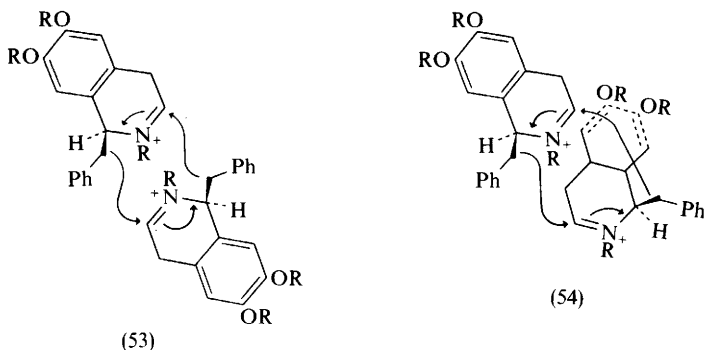

of (+)-(51; $R^1 = R^2 = \text{Me}$; $R^3 = \text{Me}$) and (-)-(51; $R^1 + R^2 = \text{CH}_2$; $R^3 = \text{Et}$) was subjected to the reaction, since crossed products (52; $R^1 = R^2 = \text{Me}$; $R^3 = \text{Et}$) and (52; $R^1 + R^2 = \text{CH}_2$; $R^3 = \text{Me}$) were obtained in addition to (52; $R^1 = R^2 = R^3 = \text{Me}$) and (52; $R^1 + R^2 = \text{CH}_2$; $R^3 = \text{Et}$).¹²⁷ It has been noted that reduction by lithium aluminium hydride of the isoquinolinium salts (41; $R^1 = \text{Me}$; $R^2 = \text{CH}_2\text{Ph}$) and (41; $R^1 = \text{CH}_2\text{Ph}$; $R^2 = \text{Me}$) resulted in loss of the benzylic grouping and formation of 1,2-dihydro-2-methyl-6,7-methylenedioxy-1-oxoisoquinoline, whereas sodium borohydride afforded the corresponding 1-benzyl-1,2-dihydroisoquinolines.¹²⁸ The transformation of papaveralidine methiodide into a phthalidisoquinoline is reported in Section 14. Codamine and its methylenedioxy-analogue (55) have been converted into the corresponding 8-chloro-derivatives by treatment of the corresponding p-quinol acetate with concentrated aqueous HCl.⁹⁰

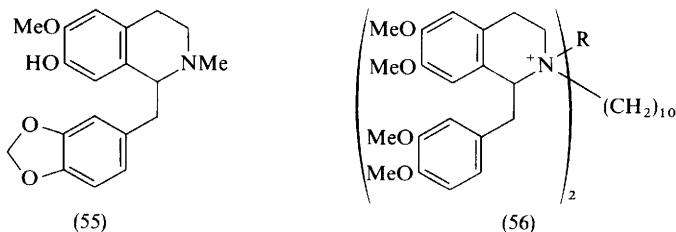

The neuromuscular blocking potencies of various D- and L-NN-dialkyltetrahydropapaverinium iodides¹²⁹ and of NN'-decamethylene-bis-tetrahydropapaverinium compounds like (56)¹³⁰ have been examined. Several compounds like (57)¹³¹ and (58)¹³² have been prepared and their sympathomimetic activities compared with that of the phenolic benzyltetrahydroisoquinoline to which they bear the closest resemblance. The synthesis and pharmacological properties of

¹²⁸ S. Natarajan and B. R. Pai, *Indian J. Chem.*, 1974, **12**, 355.

¹²⁹ J. B. Stenlake, W. D. Williams, N. C. Dhar, and I. G. Marshall, *European J. Med. Chem. Chim. Ther.*, 1974, **9**, 233 (*Chem. Abs.*, 1975, **82**, 118 758).

¹³⁰ J. B. Stenlake, W. D. Williams, N. C. Dhar, and I. G. Marshall, *European J. Med. Chem. Chim. Ther.*, 1974, **9**, 239 (*Chem. Abs.*, 1975, **82**, 57 976).

¹³¹ D. D. Miller, W. V. P. Merritt, P. F. Kador, and D. R. Feller, *J. Medicin. Chem.*, 1975, **18**, 99.

¹³² D. D. Miller, P. Oseigymah, J. Bardin, and D. R. Feller, *J. Medicin. Chem.*, 1975, **18**, 454.

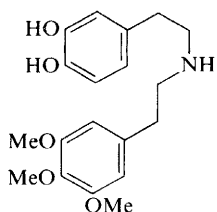

(57)

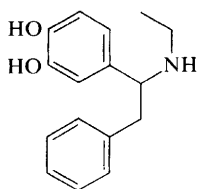

(58)

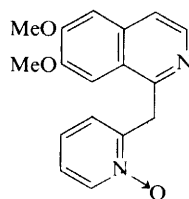

(59)

a number of new ethers of papaveraldine oxime have been reported.¹³³ The pyridyloquinoline (59) has been prepared by the Reissert method.¹³⁴ From a mass spectral investigation of 3,4-dihydropapaverine and its tetraethoxy-analogue (drotaverin) it has been concluded that these compounds have the enamine structure in the vapour phase.¹³⁵ Metabolism of the latter compound in mammals gives oxidation and desalkylation products, which have been isolated and identified.¹³⁶

Techniques have been described for determining the content in biological material of papaverine (by g.l.c.)¹³⁷ and of papaveroline (by g.c.-m.s.).¹³⁸⁻¹⁴¹

5 Pavine Alkaloids

The presence of substantial amounts of (-)-argemone (60; R = Me) and (-)-isonorargemone (60; R = H) in *Argemone munita* subsp. *argentea* distinguishes this species from *A. subintegrifolia*.¹⁴² Alkaloid isolations which have been repeated are of the quaternary alkaloid californidine (61) from *Eschscholtzia oregana*¹²¹ and of the isopavines amurensine (62; R = H)^{143,144} and amurensinine (62; R = Me)¹⁴⁴ from *Papaver pseudocanescens*. Syntheses *via* 1,2-dihydroisoquinolines of caryachine (63; R¹ = Me; R² = H) and its isomer (63; R¹ = H; R² = Me)¹⁴⁵ and of (±)-munitagine (64; R = H)¹⁴⁶ have been reported. *O,O*-Dimethylmunitagine (64;

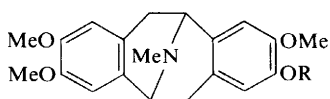

(60)



(61)

¹³³ A. Buzas, C. Egnell, R. Mathieu, F. Bourillet, J. J. Potherat, and J. C. Simon, *European J. Med. Chem. Chim. Ther.*, 1974, **9**, 571 (*Chem. Abs.*, 1975, **82**, 171 252).

¹³⁴ J. Knabe and G. Link, *Arch. Pharm. (Weinheim)*, 1975, **308**, 151.

¹³⁵ J. Tamas, K. Ujszaszy, G. Bujtas, and Z. Meszaros, *Acta Pharm. Hung.*, 1974, **44**, 7 (*Chem. Abs.*, 1975, **82**, 3530).

¹³⁶ L. Gyarmati, A. David, Z. Meszaros, I. Racz, and P. Szentmiklosi, *Pharmazie*, 1975, **30**, 174.

¹³⁷ D. E. Guttman, H. B. Kostenbauder, G. R. Wilkinson, and P. H. Dube, *J. Pharm. Sci.*, 1974, **63**, 1625.

¹³⁸ S. Algeri, A. J. Turner, A. Frigerio, and K. M. Baker, *Riv. Farmacol. Ter.*, 1973, **4**, 121a (*Chem. Abs.*, 1974, **81**, 45 175).

¹³⁹ J. L. Cashaw, K. D. McMurtrey, H. Brown, and V. E. Davis, *J. Chromatog.*, 1974, **99**, 567.

¹⁴⁰ A. J. Turner, K. M. Baker, S. Algeri, S. Frigerio, and S. Garattini, *Life Sci.*, 1974, **14**, 2247.

¹⁴¹ A. J. Turner, K. M. Baker, S. Algeri, and S. Frigerio, 'Mass Spectrom. Biochem. Med. Symp. 1973,' ed. A. Frigerio, Raven, New York, 1974, p. 99 (*Chem. Abs.*, 1975, **82**, 38 417).

¹⁴² F. R. Stermitz, J. R. Stermitz, T. A. Zononi, and J. P. Gillespie, *Phytochemistry*, 1974, **13**, 1151.

¹⁴³ V. Novak and J. Slavik, *Coll. Czech. Chem. Comm.*, 1974, **39**, 883.

¹⁴⁴ S. Pfeifer and D. Thomas, *Pharmazie*, 1972, **27**, 48.

¹⁴⁵ S. Natarajan and B. R. Pai, *Indian J. Chem.*, 1974, **12**, 550.

¹⁴⁶ F. R. Stermitz, D. K. Williams, S. Natarajan, M. S. Premila, and B. R. Pai, *Indian J. Chem.*, 1974, **12**, 1249.

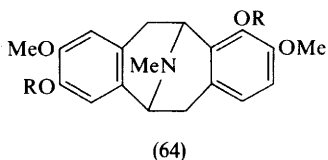
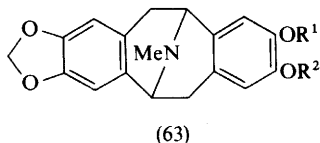
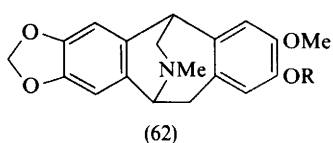

R = Me) has been synthesized from tetrahydroberberine (65) by the novel route indicated in Scheme 3.¹⁴⁷ The reaction of the degradation product (66) with methanesulphonyl chloride gave the tetracyclic salt (67). The corresponding iodide of this underwent phenyl-lithium-induced Stevens rearrangement to the pavinane (68) having the desired oxygenation pattern. A second rearrangement product was tentatively assigned structure (69).

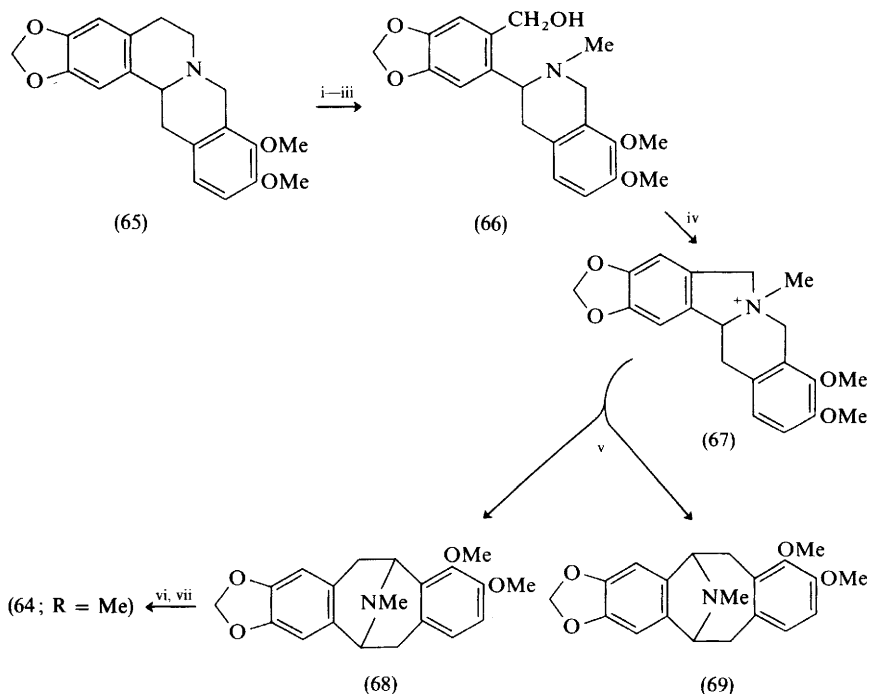

Reagents: i, Hofmann degradation; ii, OsO_4 , NaIO_4 ; iii, NaBH_4 ; iv, MeSO_2Cl , pyridine; v, PhLi , ether, room temperature; vi, BCl_3 ; vii, CH_2N_2

Scheme 3

¹⁴⁷ K. Ito, H. Furukawa, Y. Iida, K. H. Lee, and T. O. Soine, *J.C.S. Chem. Comm.*, 1974, 1037.

Bisquaternary salts (70), prepared from the enantiomers of *N*-methylpavine and 1,10-di-iodododecane, showed equal curarimetric neuromuscular blocking activity.¹¹⁰

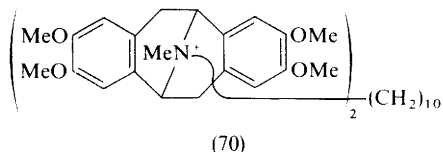

6 Dibenzopyrrocoline Alkaloids

Benzyne reaction of the bromobenzylisoquinoline (47; $R^1 = R^2 = R^3 = R^4 = \text{Me}$), using methyl sulphanyl carbanion, afforded the dibenzopyrrocoline (72) resulting from Stevens' rearrangement of the intermediate salt (71) (cf. Scheme 4).¹⁴⁸ Under similar conditions, (73) gave (74) together with the elimination product (75).

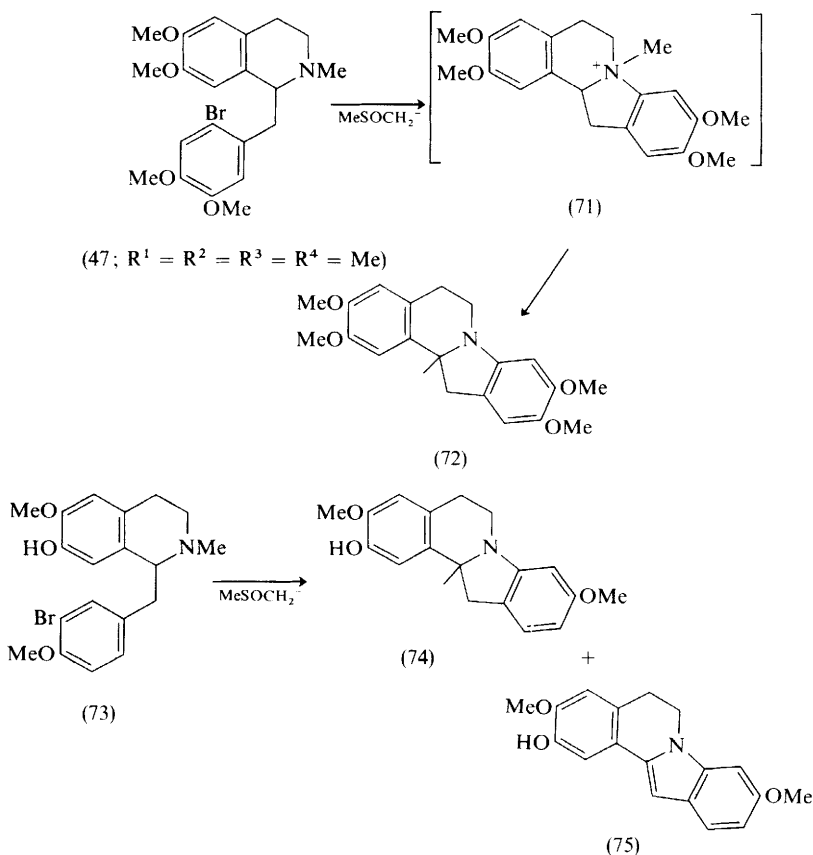

Scheme 4

¹⁴⁸ S. Kano, T. Yokomatsu, N. Yamada, K. Matsumoto, S. Tokita, and S. Shibuya, *Chem. and Pharm. Bull (Japan)*, 1974, **22**, 1607.

7 Morphine Alkaloids

Carococculine, a new sinomenine-type alkaloid isolated from the stems and leaves of *Cocculus carolinus*, has been assigned structure (76).¹⁴⁹ Sinoacutine and pallidine were obtained, together with berberine and other alkaloids, from *Corydalis koidzumiana*.¹¹⁴ *Rhigiocarya racemifera* produces one major alkaloid, which has been identified as *O*-methylflavinantine.¹⁵⁰ A new alkaloid isolated from *Stephania abyssinica* has been shown to be the dimethyl ether (77; R = Me) of stephavanine (77; R = H). Hydrolysis of each gave the alcohol stephine (*cf.* Vol. 2).¹⁵¹ No morphinans could be detected among the alkaloids found in callus tissues of various species of the Papaveraceae, including *Papaver somniferum* and *P. bracteatum*, which as plants are sources of such alkaloids.¹⁵²

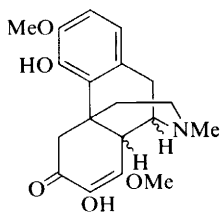

(76)

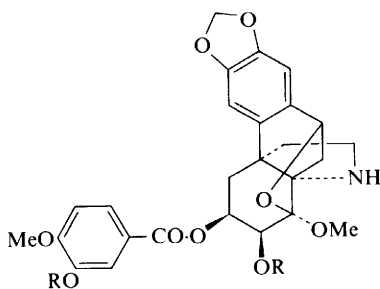

(77)

The opium alkaloid content of *P. somniferum* varieties cultivated in Bulgaria¹⁵³ and in Hokkaido¹⁵⁴ has been determined. The effects of planting density on yield of alkaloids¹⁵⁵ and of climatic variations on the accumulation of morphine in this species have been noted.¹⁵⁶ A Swedish variety has been bred to produce a low morphine content.¹⁵⁷ The alkaloids present in the stamens of *P. somniferum* at different stages of their development have been examined.¹⁰ Evidence has been produced that the alkaloids are produced, stored, and translocated in the vacuolar sap of the vesicles present in the latex of *P. somniferum*.¹⁵⁸ The thebaine content of *P. bracteatum* at various times in the growing season¹⁵⁹ and a g.l.c. method of

¹⁴⁹ D. J. Slatkin, N. J. Doorenbos, J. E. Knapp, and P. L. Schiff, jun., *Lloydia*, 1974, **37**, 488.

¹⁵⁰ A. N. Tackie, D. Dwuma-Badu, J. E. Knapp, D. J. Slatkin, and P. L. Schiff, jun., *Phytochemistry*, 1974, **13**, 2884.

¹⁵¹ A. J. Van Wyk and A. Wiechers, *J.S. African Chem. Inst.*, 1974, **27**, 95 (*Chem. Abs.*, 1975, **82**, 40 663).

¹⁵² A. Ikuta, K. Syono, and T. Furuya, *Phytochemistry*, 1974, **13**, 2175.

¹⁵³ P. Popov, I. Dimitrov, S. Georgiev, T. Deneva, and L. S. Iliev, *Farmatsiya (Sofia)*, 1974, **24**, 20 (*Chem. Abs.*, 1974, **81**, 166 307).

¹⁵⁴ S. Shirasaki, S. Honma, H. Kaneshima, Y. Kinoshita, and M. Mori, *Hokkaidoritsu Eisei Kenkyushoho*, 1973, 112 (*Chem. Abs.*, 1974, **81**, 148 467).

¹⁵⁵ Y. Hatakeyama, K. Nishi, T. Ohno, M. Ohno, M. Shimamine, and K. Takahashi, *Eisei Shikenjo Hokoku*, 1974, **92**, 32 (*Chem. Abs.*, 1975, **82**, 167 546).

¹⁵⁶ V. M. Malinina and R. M. Ivanova, *Doklady Vses. Akad. Sel'skokhoz Nauk.*, 1974, 19 (*Chem. Abs.*, 1974, **81**, 60 831).

¹⁵⁷ U. Nyman and O. Hall, *Hereditas*, 1974, **76**, 49 (*Chem. Abs.*, 1974, **81**, 132 961).

¹⁵⁸ J. W. Fairbairn, F. Hakin, and Y. El Kheir, *Phytochemistry*, 1974, **13**, 1133.

¹⁵⁹ Y. Aynehchi and S. Jaffarian, *Lloydia*, 1973, **36**, 427.

determining thebaine in this plant have been described.¹⁶⁰ This was the only alkaloid detected in a new population of *P. bracteatum* found in West Iran.¹⁶¹

The configuration and conformation for dihydrometacodeinone (78) determined by X-ray crystallography are in agreement with assignments from n.m.r. spectroscopy.¹⁶² Degradation of 9,10-dehydroindolinocodeine methoperchlorate (79) with sodium methoxide gave (7*R*)-7-methoxyneopine methine (80). This gave the phenanthrofurans (81; R = OMe) (by Hofmann degradation) and (81; R = H) (by heating the mesylate in quinoline).¹⁶³

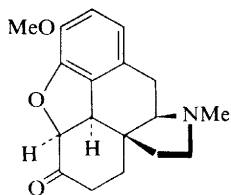

(78)

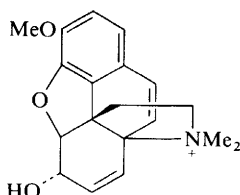

(79)

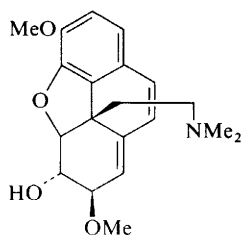

(80)

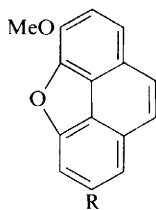

(81)

Further attention has been given to the electro-oxidative preparation of morphinandienones^{164,165} (*cf.* Vol. 4). It has been proposed that, at low potentials, the amine functionality anchimerically assists the coupling (Scheme 5).¹⁶⁴ The effect of the nitrogen functionality is also evident in the results of electro-oxidative coupling of the dihydrostilbenes (82; R = CF₃) and (82; R = OEt) to give the dienone (83) and the rearranged dienone (84), respectively (Scheme 6).¹⁶⁵ Oxidation by thallium(III) trifluoroacetate of the *N*-trifluoroacetyl and *N*-ethoxycarbonyl derivatives of *N*-nor-reticuline gives the corresponding *N*-substituted norsalutaridine (85) (11% and 23%, respectively), offering a considerable improvement on the biogenetically patterned route to the morphine alkaloids.¹⁶⁶ The morphinandienone-type compound (87) was formed in low yield, together with aporphines, by Schorr-type cyclization of (86).¹⁶⁷

¹⁶⁰ J. W. Fairbairn and K. Helliwell, *J. Pharm. Pharmacol.*, 1975, **27**, 217.

¹⁶¹ I. Lalezari, P. Nasser, and R. Asgharian, *J. Pharm. Sci.*, 1974, **63**, 1331.

¹⁶² U. Weiss, J. V. Tillack, and C. H. L. Kennard, *Proc. Roy. Austral. Chem. Inst.*, 1974, **41**, 106 (*Chem. Abs.*, 1974, **81**, 37 684).

¹⁶³ H. Bartsch and F. Vieboeck, *Monatsh.*, 1974, **105**, 340.

¹⁶⁴ L. L. Miller, F. R. Stermitz, J. Y. Becker, and V. Ramachandran, *J. Amer. Chem. Soc.*, 1975, **97**, 2922.

¹⁶⁵ T. Kametani, K. Shishido, and S. Takano, *J. Heterocyclic Chem.*, 1975, **12**, 305.

¹⁶⁶ M. A. Schwartz and I. S. Mami, *J. Amer. Chem. Soc.*, 1975, **97**, 1239.

¹⁶⁷ T. Kametani, T. Suguhara, and K. Fukumoto, *Chem. and Pharm. Bull. (Japan)*, 1974, **22**, 966.

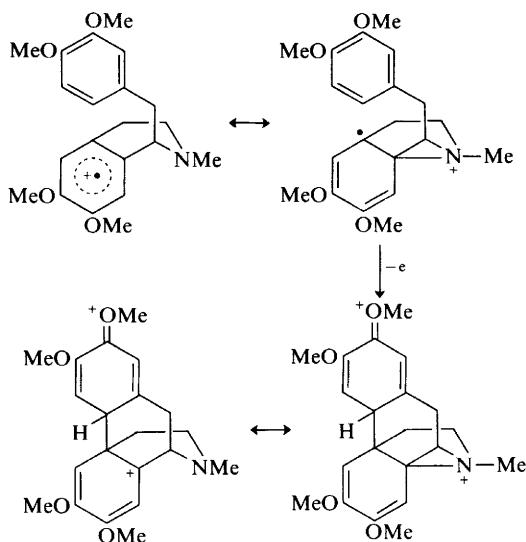

Scheme 5

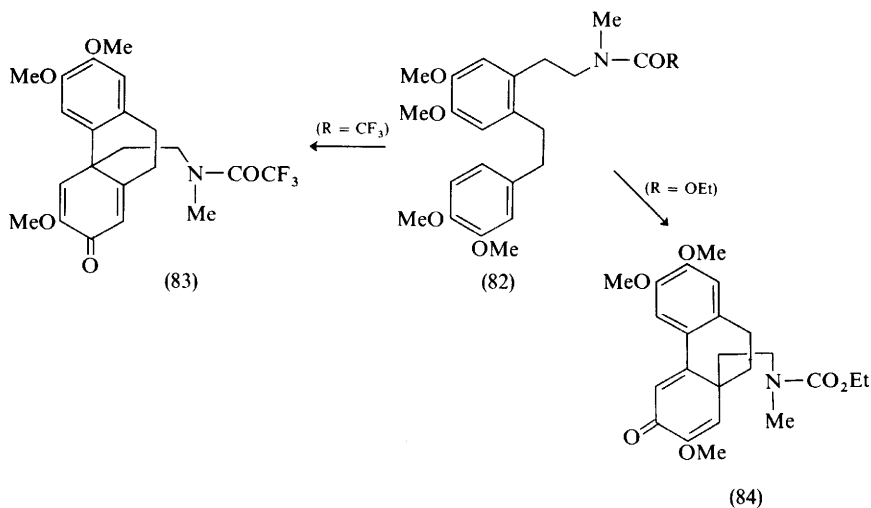

Scheme 6

Full details of the total syntheses of (\pm)-metaphanine¹⁶⁸ (cf. Vol. 3) and of (\pm)-hasubanone (88; R¹ = Me; R² = H₂)¹⁶⁹ have appeared. The penultimate stage in the synthesis of the latter, involving reaction of the diketone (89) with

¹⁶⁸ T. Ibuka, K. Tanaka, and Y. Inubushi, *Chem. and Pharm. Bull. (Japan)*, 1974, **22**, 907.

¹⁶⁹ T. Ibuka, K. Tanaka, and Y. Inubushi, *Chem. and Pharm. Bull. (Japan)*, 1974, **22**, 782.

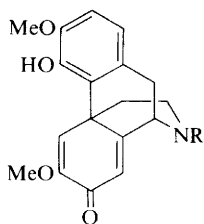

(85)

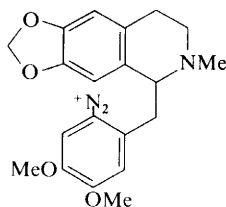

(86)

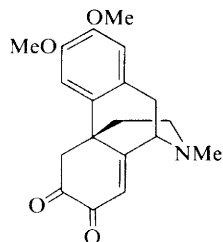

(87)

diazomethane, afforded a mixture of products including 16-oxohasubanonine (88; $R^1 = \text{Me}$; $R^2 = \text{O}$) and (\pm)-aknidilactam (88; $R^1 = \text{H}$; $R^2 = \text{O}$).¹⁶⁹

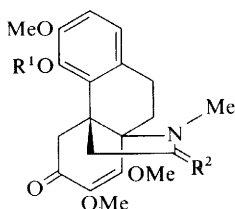

(88)

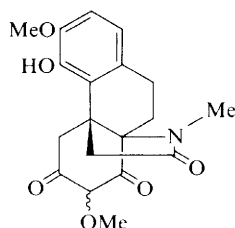

(89)

A review of the synthesis of morphinans includes discussion of the possible mechanism of formation of isomorphinans.¹⁷⁰ The amine (91; $R = \text{H}$) has been used as the key intermediate in the total synthesis not only of 3,14-dihydroxymorphinans¹⁷¹ and 9 α -hydroxy-3-methoxyhasubanans¹⁷² but also of the first 3,14-dihydroxyisomorphinans,¹⁷² e.g. (94), (Scheme 7). Treatment of the morphinan thiocarboxamide (90; $R = \text{CSNHPh}$) with acid, instead of giving a 14-mercaptomorphinan derivative, caused isomerization first to the hasubanan (95) (presumably *via* an aziridinium intermediate) and then to the thiazinohasubanan (96) (*cf.* Scheme 8).¹⁷³ Mechanisms for these transformations have been discussed in the light of deuterium incorporations observed when $^2\text{H}_2\text{SO}_4$ or ^2HCl was used. The last compound was converted, *via* an 8-mercapto-compound, into the hasubanan (97; $R = \text{H}$). The structure of this was confirmed by synthesis from (91; $R = \text{H}$) of the product obtained from its Hofmann degradation.¹⁷³

In a study of the Grewe method of codeine synthesis, the *p*-bromophenol (98) and its *N*-methoxycarbonyl derivative failed to undergo acid-catalysed cyclization to a morphinan. Also, although 2-hydroxydihydronorthebainone (99) was readily obtained by cyclization of (100), removal of the 2-hydroxy-group could not be

¹⁷⁰ M. Gates, *Adv. Biochem. Psychopharmacol.*, 1973, **8**, 51.

¹⁷¹ I. Monković, T. T. Conway, H. Wong, Y. G. Perron, I. J. Pachler, and B. Belleau, *J. Amer. Chem. Soc.*, 1973, **95**, 7910.

¹⁷² B. Belleau, H. Wong, I. Monković, and Y. G. Perron, *J.C.S. Chem. Comm.*, 1974, 603.

¹⁷³ M. Saucier and I. Monković, *Canad. J. Chem.*, 1974, **52**, 2736.

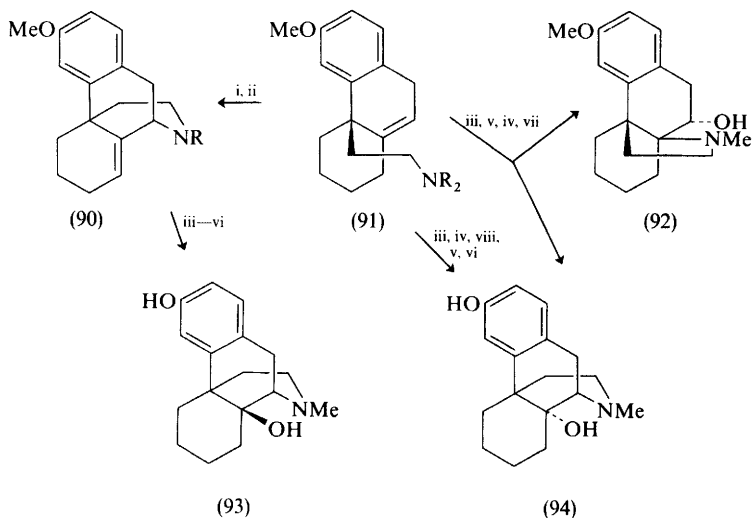

Reagents: i, Br₂, CHCl₃; ii, NaHCO₃, DMF, 130—135 °C; iii, ClCO₂Et, Et₃N; iv, *m*-ClC₆H₄-CO₂H; v, LiAlH₄; vi, BBr₃, CH₂Cl₂; vii, K₂CO₃, aq. MeOH; viii, sodium *t*-pentyl oxide

Scheme 7

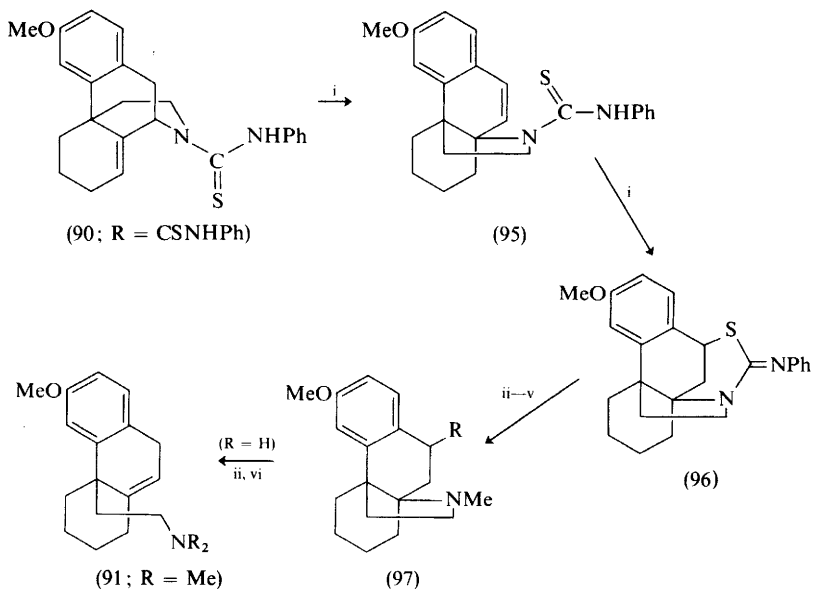

Reagents: i, conc. H₂SO₄ or conc. HCl aq.; ii, MeI; iii, LiAlH₄; iv, Raney Ni; v, H₂, Raney Ni, CH₂O; vi, KOH, BuOH

Scheme 8

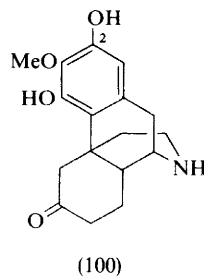
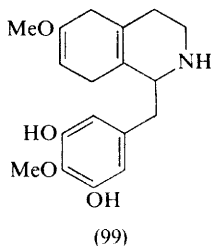
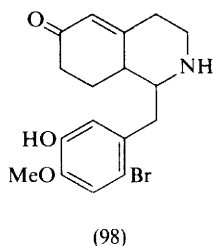

achieved.¹⁷⁴ 3-Deoxydihydemorphine has been prepared by catalytic hydrogenation of the 1-phenyltetrazol-5-yl or 2-pyrimidyl ether of morphine.^{175,176} 14-Hydroxycodeinone is obtained in a single operation by treatment of thebaine with *m*-chloroperbenzoic acid.¹⁷⁷

There has been some interest in the stereochemistry of reactions at C-6 in morphine derivatives. Borohydride reduction of the narcotic antagonist naloxone (101; R = allyl) gave a mixture of alcohols consisting mainly of the 6 α -hydroxy-derivative, identical with the principal metabolite *in vivo*. The 6 β -hydroxy epimer, forming 10% of the mixture, was isolated by liquid chromatography and was also obtained *via* solvolysis of the 6 α -tosyloxy-derivative.¹⁷⁸ Reduction of naloxone and naltrexone (101; R = cyclopropylmethyl) with thiourea dioxide (formamidinesulphonic acid) in aqueous alkali¹⁷⁹ is reported, on the other hand, to give only the 6 β -hydroxy-derivatives.¹⁸⁰ It has been reported that the major urinary metabolite of naltrexone administered to humans is the 6 β -hydroxy-epimer,^{181,182} while a chicken

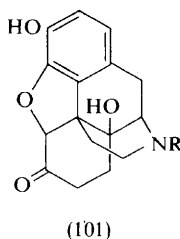

liver-enzyme system converted it into the 6 α -hydroxy-epimer.¹⁸¹ In the reaction of naloxone with methyl-lithium, attack of the reagent was again predominantly from the β -side, giving a 20:1 mixture of the 6 β -methyl-6 α -alcohol and its epimer.¹⁷⁷ Dihydrocodeinone and its 14-hydroxy-analogue (101; R = Me) similarly afforded

¹⁷⁴ J. I. De Graw, J. C. Christensen, V. H. Brown, and M. J. Cory, *J. Heterocyclic Chem.*, 1974, **11**, 363.

¹⁷⁵ R. Bogнар, G. Gaal, P. Kerekes, G. Horvath, and M. T. Kovacs, *Org. Prep. Proced. Internat.*, 1974, **6**, 305.

¹⁷⁶ R. Bogнар, G. Gaal, P. Kerekes, G. Horvath, and M. T. Kovacs, *Magyar Kém. Folyóirat*, 1975, **81**, 51 (*Chem. Abs.*, 1975, **82**, 156 537).

¹⁷⁷ F. M. Hauser, T.-K. Chen, and F. I. Carroll, *J. Medicin. Chem.*, 1974, **17**, 1117.

¹⁷⁸ E. F. Hahn and J. Fishman, *J. Org. Chem.*, 1975, **40**, 31.

¹⁷⁹ K. Nakagawa and K. Minami, *Tetrahedron Letters*, 1972, 343.

¹⁸⁰ N. Chatterjee, C. E. Inturrisi, H. B. Dayton, and H. Blumberg, *J. Medicin. Chem.*, 1975, **18**, 490.

¹⁸¹ N. Chatterjee, J. M. Fujimoto, C. E. Inturrisi, S. Roerig, R. I. H. Wang, D. V. Bowen, F. H. Field, and D. D. Clarke, *Drug Metab. Dispos.*, 1974, **2**, 401 (*Chem. Abs.*, 1975, **82**, 92 863).

¹⁸² E. J. Cone, *Tetrahedron Letters*, 1973, 2607.

6 β -methyl-6 α -hydroxy-derivatives. The epimeric alcohols were obtained by reaction with dimethylsulphoxonium methylide followed by hydride reduction of the resulting oxetan.¹⁸³ The metabolic fates of morphine, codeine, and heroin have been reviewed.¹⁸⁴

Numerous methods, old and new, continue to be applied to the analysis of morphine and related compounds, and recent work is summarized in Table 5. A review of such methods¹⁸⁵ and another on the detection of opiates and other narcotics in the urine¹⁸⁶ have appeared. Critical assessments have been made of

Table 5 Analysis of morphine alkaloids

Substance analysed	Methods
Codeine	G.l.c.; ^a liquid chromatography ^{b,c}
Heroin	G.l.c.; ^d liquid chromatography ^c
Morphine	Autoanalyser; ^e chemical ionization and electron impact m.s.; ^f chromatography-colorimetry; ^g electron-capture g.c.; ^h fluorimetry; ⁱ g.l.c.; ^{a,i} g.c.-chemical ionization m.s.; ^k g.c.-m.s.; ^e gravimetric, titrimetric analysis; ^m haemagglutination inhibition; ⁿ latex agglutination inhibition; ^o liquid chromatography; ^{b,c} mass fragmentography; ^p radioimmunoassay; ^q spin-label immunoassay; ^r t.l.c.; ^s t.l.c.-g.l.c. ^t
Morphine metabolites	T.l.c. ^u
Opium alkaloids	T.l.c. ^v
Synthetic	G.l.c.; ^w t.l.c.-g.l.c. ^t
Thebaine	Liquid chromatography ^{b,c}

^a G. R. Nakamura and T. T. Noguchi, *J. Forensic Sci. Soc.*, 1974, **14**, 347; G. R. Nakamura and E. L. Way, *Analyt. Chem.*, 1975, **47**, 775; ^b T. H. Beasley, D. W. Smith, H. W. Ziegler, and R. L. Charles, *J. Assoc. Offic. Analyt. Chemists*, 1974, **57**, 85; ^c R. Verpoorte and A. B. Svendsen, *J. Chromatog.*, 1974, **100**, 227; ^d D. A. Smith and W. J. Cole, *J. Chromatog.*, 1975, **105**, 377; ^e J. B. Powell, J. I. Davis, C. H. Tripp, jun., and C. R. Angel, *Adv. Autom. Anal. Technol. Int. Congr.* 1972, 1973, **6**, 12; ^f I. Jardine and C. Fenselau, *Analyt. Chem.*, 1975, **47**, 730; ^g R. Adamski and M. Stojaczyk, *Farm. Pol.*, 1974, **30**, 517 (*Chem. Abs.*, 1975, **82**, 7670); ^h B. Dahlstrom and L. Paalzow, *J. Pharm. Pharmacol.*, 1975, **27**, 172; J. E. Wallace, H. E. Hamilton, K. Blum, and C. Petty, *Analyt. Chem.*, 1974, **46**, 2107; ⁱ L. R. Goldbaum and W. L. Allinger, *Adv. Autom. Anal. Technicon, Int. Cong.* 1972, 1973, **6**, 21; M. Sansur, H. J. Adler, and D. A. Burns, *Adv. Autom. Anal. Technicon, Int. Congr.* 1972, 1973, **6**, 3; D. J. Doedens and R. B. Forney, *J. Chromatog.*, 1974, **100**, 225; ^j D. E. Fry, P. D. Wills, and R. G. Twycross, *Clinica Chim. Acta*, 1974, **51**, 183; R. Truhaut, A. Esmailzadeh, J. Lebbe, J. P. Lafarge, and P. L. Nguyen, *Ann. Biol. Clin. (Paris)*, 1974, **32**, 429; ^k P. A. Clarke and R. L. Foltz, *Clinical Chem.*, 1974, **20**, 465; ^l B. Holmstedt and J. E. Lindgren, *Ciba Found. Symp.* 1974, **26** (*Poisoned Patient Role Lab.*), p. 105; ^m V. S. Ramanathan and C. Ramachandran, *Bull. Narc.*, 1974, **26**, 69; ⁿ F. L. Adler, 'Immunoassays for Drugs Subject to Abuse', ed. S. J. Mule, C.R.C., Cleveland, Ohio, 1974, p. 37; ^o R. Ross, C. A. Horwitz, H. Hager, M. Usategui, M. D. Burke, and P. C. J. Ward, *Clinical Chem. (Winston-Salem, N.C.)*, 1975, **21**, 139; ^p P. A. Clarke and R. L. Foltz, *Proc. Int. Conf. Stable Isotope Chem. Biol. Med.*, 1st 1973, ed. P. D. Klein, N.T.I.S., Springfield, Virginia, 1973, p. 321; ^q R. J. Coumbis and B. Kaul, *J. Forensic Sci.*, 1974, **19**, 307; M. Koida, M. Takahashi, and H. Kaneto, *Jap. J. Pharmacol.*, 1974, **24**, 707; S. Spector and A. Seidner, 'Immunoassays for Drugs Subject to Abuse', ed. S. J. Mule, C.R.C., Cleveland, Ohio, 1974, p. 13; ^r R. Leute, *Ann. New York Acad. Sci.*, 1973, **222**, 1087; E. S. Copeland, *ibid.*, p. 1079; M. R. Montgomery and J. L. Holtzman, *Drug Metab. Dispos.*, 1974, **2**, 391; ^s A. F. Rubtsov and E. M. Salomatina, *Sub-Med Ekspert*, 1974, **17**, 45 (*Chem. Abs.*, 1974, **81**, 99 154); ^t G. J. Di Gregoro and C. O'Brien, *J. Chromatog.*, 1974, **101**, 424; ^u A. Klutch, *Drug Metab. Dispos.*, 1974, **2**, 23; ^v G. C. Jain and M. S. Dahya, *Current Sci.*, 1974, **43**, 444; ^w A. Noirfalise, *J. Chromatog.*, 1974, **90**, 392.

¹⁸³ G. Horvath, P. Kerekes, G. Gaal, and R. Bognar, *Acta Chim. Acad. Sci. Hung.*, 1974, **82**, 217 (*Chem. Abs.*, 1974, **81**, 152 461).

¹⁸⁴ A. Viala and M. Estadiou, *Trav. Soc. Pharm. Montpellier*, 1974, **33**, 563 (*Chem. Abs.*, 1974, **81**, 9533).

¹⁸⁵ S. J. Mule, *J. Chromatog. Sci.*, 1974, **12**, 245.

¹⁸⁶ J. Baeumler and S. Rippstein, *Mitteilungsbl. Ges. Deut. Chem. Fachgruppe Lebensmittelchem. Gerichl. Chem.*, 1974, **28**, 39 (*Chem. Abs.*, 1974, **81**, 33 954).

immuno-assay^{187,188} and chromatographic-spectroscopic¹⁸⁹ procedures for morphine analysis and of methods of detecting heroin in the urine^{190,191} and in plasma and saliva.¹⁹² Improvements variously suggested for extraction of morphine from biological fluids are the use of amyl alcohol,¹⁹³ isopropyl alcohol,¹⁹⁴ and non-ionic XAD-2 resin.¹⁹⁵ Extraction from the urine is enhanced by pretreatment with acid to hydrolyse conjugates.¹⁹⁶

The morphine-fragment type of compound has continued to attract interest. An improved synthesis and new pharmacological data on the analgesic morphan (102) have been described¹⁹⁷ and its 1*R*,5*S* absolute configuration has been established by X-ray crystallography.¹⁹⁸ Of two series of benzazocine derivatives which were synthesized,^{199,200} compounds (103; R¹ = MeO; R² = R³ = Me; R⁴ = H) and (103; R¹ = R² = R³ = H; R⁴ = CH₂Ph) were the most potent analgesics. Several new

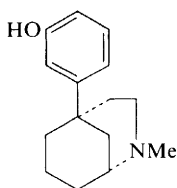

(102)

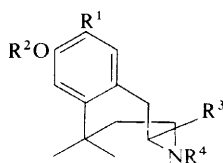

(103)

homobenzomorphans, e.g. (104),²⁰¹ and 9,9-dialkylbenzomorphans, e.g. (105),²⁰² have been prepared and found to be potent antagonists. The new benzomorphan (106) had no analgesic activity.²⁰³ The lack of such activity in ring D analogues, e.g. (107; R = OH) of *N*-methylmorphinan, is attributed to a critical effect of the nitrogen lone-pair orientation.^{204,205} X-Ray crystallographic studies show that the lone pair in (107; R = H) projects towards the aryl ring rather than away from it, as in morphinan.²⁰⁴ A variety of benzomorphans, e.g. the tetrahydrofuran (108), can be

¹⁸⁷ D. H. Catlin, in 'Immunoassays for Drugs Subject to Abuse', ed. S. J. Mule, C.R.C., Cleveland, Ohio, 1974, p. 91.

¹⁸⁸ C. W. Parker, 'Ciba Foundation Symp. 1974, 26, (Poisoned Patient Role Lab.)', 1974, p. 201.

¹⁸⁹ A. C. Moffatt, 'Ciba Foundation Symp., 1974, 26, (Poisoned Patient Role Lab.)', 1974, p. 83.

¹⁹⁰ C. W. Gorodetzky, C. R. Angel, D. J. Beach, D. H. Catling, and S.-Y. Yeh, *Clin. Pharmacol. Ther.*, 1974, **15**, 461.

¹⁹¹ H. E. Sine, W. P. Kubasik, and T. A. Rejent, *Clinical Biochem.*, 1974, **7**, 102.

¹⁹² C. W. Gorodetzky and M. P. Kullberg, *Clin. Pharmacol. Ther.*, 1974, **15**, 579.

¹⁹³ V. Antonescu, *Farmacia (Bucharest)*, 1974, **22**, 87 (*Chem. Abs.*, 1975, **82**, 10 977).

¹⁹⁴ S. J. Goldner, C. J. Umberger, D. B. Hoffman, G. Gourdet, S. Andryauskas, and J. R. Broich, *Biochem. Med.*, 1974, **10**, 79.

¹⁹⁵ W. L. Miller, M. P. Kullberg, M. E. Banning, L. D. Brown, and B. P. Doctor, *Biochem. Med.*, 1973, **7**, 145.

¹⁹⁶ T. N. Higgins and J. D. Taylor, *Clinical Biochem.*, 1974, **7**, 280.

¹⁹⁷ M. E. Rogers and E. L. May, *J. Medicin. Chem.*, 1974, **17**, 1328.

¹⁹⁸ T. G. Cochran, *J. Medicin. Chem.*, 1974, **17**, 987.

¹⁹⁹ Y. Sawa, T. Kato, T. Masuda, M. Hori, and H. Fujimura, *Yakugaku Zasshi*, 1975, **95**, 251.

²⁰⁰ Y. Sawa, T. Kato, A. Morimoto, T. Masuda, M. Itori, and H. Fujimura, *Yakugaku Zasshi*, 1975, **95**, 261.

²⁰¹ M. Takeda, M. Kondo, H. Inoue, S. Saito, H. Kugita, and S. Nurimoto, *Adv. Biochem. Psychopharmacol.*, 1973, **8**, 113.

²⁰² P. A. J. Janssen, *Adv. Biochem. Psychopharmacol.*, 1973, **8**, 109.

²⁰³ P. K. Khandelwal and B. C. Joshi, *Defence Sci. J. (New Delhi)*, 1973, **23**, 145 (*Chem. Abs.*, 1974, **81**, 63 814).

²⁰⁴ B. Belleau, T. Conway, F. R. Ahmed, and A. D. Hardy, *J. Medicin. Chem.*, 1974, **17**, 907.

²⁰⁵ B. Belleau and P. Morgan, *J. Medicin. Chem.*, 1974, **17**, 908.

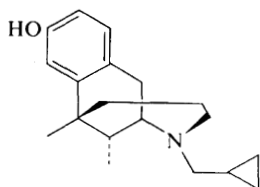

(104)

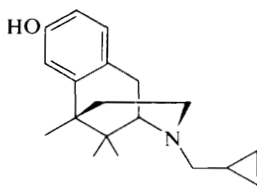

(105)

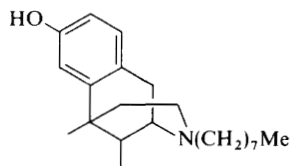

(106)

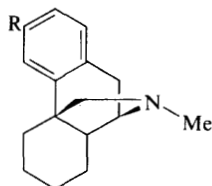

(107)

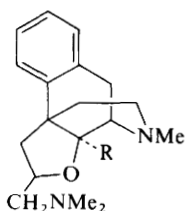

(108)

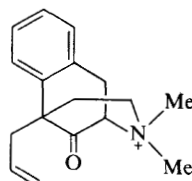

(109)

prepared from the readily available 5-allyl-9-oxobenzomorphan (109).²⁰⁶ Some thienomorphans have also been synthesized.²⁰⁷

Reports have appeared on the mass spectra²⁰⁸ and pharmacology²⁰⁹ of various azidomorphine derivatives. Etorphine hydrochloride produces rapid and complete immobilization of rats and dogs²¹⁰ and has been found suitable for field use with brown bears.²¹¹

8 Colchicine Alkaloids

The isolation of desacetylcolchicine from *Kreysigia multiflora* has been reported.²¹²

Synthesis of the tropolone (110), known to be convertible into colchicine, has been achieved by solvolysis of the dichloroketen-substituted cyclopentadiene adduct (111).²¹³ Speciosine (112; R = 2-HOC₆H₄CH₂) can be converted into colchamine (112; R = H) by refluxing in benzyl alcohol. This elimination is also evident in its mass spectrum.²¹⁴ The amino-functions in these two alkaloids, as well as those in *N*-methylcolchamine, colchicine, and *N*-acetylcolchicine, adopt an equatorial configuration, as judged by the *trans*-diaxial-type coupling constant shown by the n.m.r. absorption signals for the geminal proton at C-7.²¹⁵ The ¹³C n.m.r. spectrum of

²⁰⁶ I. Monkovic, *Canad. J. Chem.*, 1975, **53**, 1189.

²⁰⁷ T. A. Montzka and J. D. Matiske, *J. Heterocyclic Chem.*, 1974, **11**, 853.

²⁰⁸ J. Tanas, M. Mak, and S. Makleit, *Org. Mass. Spectrometry*, 1974, **9**, 847.

²⁰⁹ J. Knoll, S. Fürst, and S. Makleit, *J. Pharm. Pharmacol.*, 1975, **27**, 99.

²¹⁰ B. F. Kania, *Med. Weter.*, 1974, **30**, 746 (*Chem. Abs.*, 1975, **82**, 119 108).

²¹¹ L. E. Beeman, M. R. Pelton, and L. C. Marcum, *J. Wildlife Management*, 1974, **38**, 567 (*Chem. Abs.*, 1975, **82**, 51 523).

²¹² A. R. Battersby, R. B. Bradbury, R. B. Herbert, M. H. G. Munro, and R. Ramage, *J.C.S. Perkin I*, 1974, 1394.

²¹³ M. Kato, F. Kido, M.-D. Wu, and A. Yoshikoshi, *Bull. Chem. Soc. Japan*, 1974, **47**, 1516.

²¹⁴ V. V. Kiselev, Y. V. Rashkes, and S. Yu. Yunusov, *Khim. prirod. Soedinonii*, 1974, 536 (*Chem. Abs.*, 1975, **82**, 73 253).

²¹⁵ V. V. Kiselev and M. E. Perelson, *Khim. prirod. Soedinonii*, 1974, 535 (*Chem. Abs.*, 1975, **82**, 16 965).

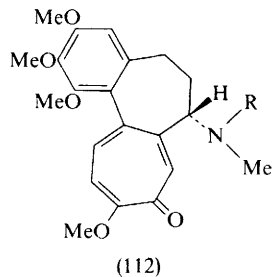
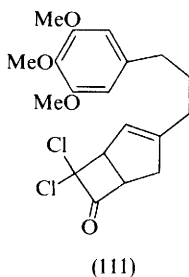
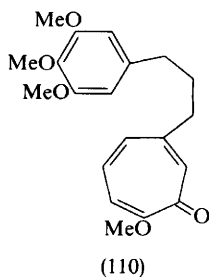

colchicine has been recorded as part of a successful ^{13}C tracer demonstration of its biosynthesis from (*S*)-autumnaline.²¹⁶

Gel chromatography has been used to isolate colchicine and colchamine from biological material.²¹⁷ An assay of colchicine using adsorption chromatography has also been described.²¹⁸

Structural evidence for a series of colchicine derivatives (113; R = alkyl) has been provided by i.r. spectroscopy.²¹⁹ Another series of derivatives, prepared by the

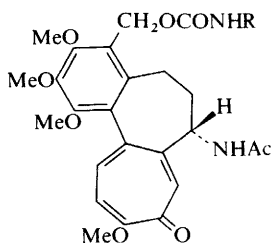

reaction of colchicine with alkanethiols, and the corresponding desacetyl compounds have been tested for antileukaemic activity.²²⁰ An extensive survey of plants for new antifertility agents includes a discussion on colchamine.²²¹ The use of colchicine in the treatment of gout has been reviewed,²²² and the alkaloid also appears now to be effective in the treatment of familial Mediterranean fever.^{223,224}

²¹⁶ A. R. Battersby, P. W. Sheldrake, and J. A. Milner, *Tetrahedron Letters*, 1974, 3315.

²¹⁷ V. I. Svetlichnaya and G. V. Kramarenko, *Farm. Zhur. (Kiev)*, 1974, **29**, 93 (*Chem. Abs.*, 1974, **81**, 100 259).

²¹⁸ F. T. Hussein and M. A. Nasra, *Planta Med.*, 1974, **25**, 396.

²¹⁹ E. Cionga, V. Ursu-Kenyeres, I. Ursu-Kenyeres, and L. Chirita, *Farmaicia (Bucharest)*, 1973, **21**, 649 (*Chem. Abs.*, 1974, **81**, 63 813).

²²⁰ G. T. Shiau, K. K. De, and R. E. Harmon, *J. Pharm. Sci.*, 1975, **64**, 646.

²²¹ N. R. Farnsworth, A. S. Bingel, G. A. Cordell, F. A. Crane, and H. H. S. Fong, *J. Pharm. Sci.*, 1975, **64**, 717.

²²² T. J. Fitzgerald, *Med. Chem. Ser. Monogr.*, 1974, **13**, 295.

²²³ C. A. Dinarello, S. M. Wolff, S. E. Goldfinger, D. C. Dale, and D. W. Allinger, *New England J. Medicine*, 1974, **291**, 934.

²²⁴ D. Zermer, M. Revach, M. Pras, B. Modan, S. Schor, E. Sohar, and J. Gafni, *New England J. Medicine*, 1974, **291**, 932.

9 Cularine Alkaloids

Synthesis of (\pm)-cularicine (114) by the established route *via* (115) has been recorded.²²⁵ Details have appeared of synthetic studies on cularine, including the successful phenolic oxidative coupling route employing the new variant of the Pomerantz-Fritsch cyclization⁹² to obtain 8-benzyloxy-7-methoxy-isoquinoline and the Reissert method for introducing the benzyl substituent.⁸⁸

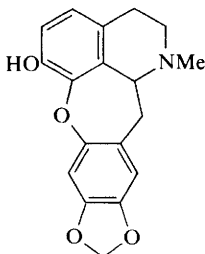

(114)

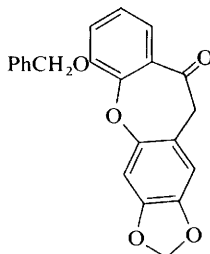

(115)

10 Protoberberine Alkaloids

Alkaloid isolation and structural elucidation are summarized in Table 6. The presence of berberine in *Argemone subintegrifolia* helps to distinguish this species chemically from *A. munita* subsp. *argentea*.¹⁴² The herb *Corydalis koidzumiana* affords eight known protoberberine alkaloids¹¹⁴ together with corydalizine. Full details of the structural elucidation and synthesis of the latter have been published.²²⁶ (-)-13 β -Hydroxystylopine, a new alkaloid that was isolated, together with (-)-canadine and (-)-stylopine, from *Corydalis ophiocarpa*, has been assigned the (13*R*,14*R*) structure (116; $R^1 + R^2 = \text{CH}_2$) from comparison of n.m.r. and o.r.d. data with those of (-)-ophiocarpine (116; $R^1 = R^2 = \text{Me}$). Structural confirmation was provided by a synthesis of (\pm)-13 β -hydroxystylopine from protopine.²²⁷

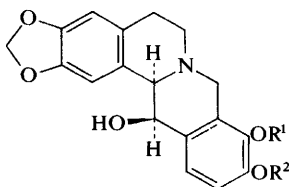

(116)

Capauridine and capaurimine were detected in redifferentiated plantlets of *Corydalis pallida*, whereas the alkaloids of callus tissues included none of the former and only small amounts of the latter alkaloid.¹⁵² (-)-Coptisine was isolated from seeds of *Fumaria indica*,²²⁸ the racemic form being a known constituent of the whole plant.²²⁹

²²⁵ I. Noguchi and D. B. Maclean, *Canad. J. Chem.*, 1975, **53**, 125.

²²⁶ C. Tani, N. Nagakua, and S. Hattori, *Chem. and Pharm. Bull. (Japan)*, 1975, **23**, 313.

²²⁷ P. W. Jeffs and J. D. Scharver, *J. Org. Chem.*, 1975, **40**, 644.

²²⁸ V. B. Pandey, A. B. Ray, and B. Dasgupta, *Current Sci.*, 1964, **43**, 748.

²²⁹ V. B. Pandey, B. Dasgupta, and S. Ghosal, *J. Inst. Chem. Calcutta*; 1974, **46**, Pt. 4, p. 120.

Table 6 Isolation of protoberberine alkaloids

Species	Alkaloid	Ref.
<i>Argemone mexicana</i>	L-(–)-Cheilanthifoline, (–)- β -Scoulerine methohydroxide, α -Stylopine methohydroxide, β -Stylopine methohydroxide	230
<i>A. ochroleuca</i> , <i>A. platycerus</i>	(–)- α -Stylopine methohydroxide	121
<i>A. polyanthemus</i>	Coptisine, (–)-Scoulerine	231
<i>A. subintegrifolia</i>	Berberine	142
<i>Berberis oblonga</i>	Berberine	254
<i>Corydalis incisa</i>	(–)-Cheilanthifoline, Coreximine Corydalisol, Corydalispirone ^a	113 232
<i>C. koidzumiana</i>	(–)-Scoulerine (–)-Capaurine, (–)-Cheilanthifoline, (+)-Corybulbine Corydalidine (+)-Corydaline, (–)-Isocorypalmine, (–)-Scoulerine, (+)-Stylopine, (\pm)-Tetrahydropalmatine	113 114 226 114
<i>C. ophiocarpa</i>	13 β -Hydroxystylopine, (–)-Stylopine, (–)-Canadine	227
<i>C. pallida</i>	Capauridine, Capaurimine ^b	152
<i>C. sempervirens</i>	Coptisine	<i>d</i>
<i>Eschscholtzia californica</i>	(–)- α -Stylopine methohydroxide	121
<i>E. oregana</i>	Berberine, Coptisine, Scoulerine (–)- α -Stylopine methohydroxide	121
<i>Fumaria indica</i>	(\pm)-Tetrahydrocoptisine, (–)-Tetrahydrocoptisine ^c	229 228
<i>Glaucium flavum</i>	Coptisine	270
<i>G. corniculatum</i>	β -Stylopine methohydroxide	121
<i>Hydrastis canadensis</i>	Canadoline	233
<i>Papaver rhoeas</i> , <i>P. syriacum</i>	β -Stylopine methohydroxide	121
<i>P. pseudocandescens</i>	Alborine Mecambridine Mecambridine methohydroxide	143, 144 143, 144 143

^a Probably identical with hypecorinine; ^b Also present in callus tissues; ^c From the seeds; ^d V. Preininger, J. Vesely, O. Gasic, V. Simanek, and L. Dolejs, *Coll. Czech. Chem. Comm.*, 1975, **40**, 699.

The properties of the diastereoisomeric α - and β -forms of the metho-salts of (–)-stylopine have been determined. These are both formed by methylation of (–)-stylopine, although the β -form constitutes more than 90% of the product. It was established that the α -form was present in *Argemone ochroleuca*, *A. platycerus*,

Eschscholtzia oregana, and *E. californica* and the *β*-form in *Glaucium corniculatum*, *Papaver rhoeas*, and *P. syriacum*.¹²¹ The alkaloid content of *Argemone mexicana*, and particularly the presence of four quaternary bases, namely (–)-*β*-scoulerine methohydroxide, (–)-cheilanthifoline, and both the *α*- and *β*-methohydroxides of (–)-stylophine, suggests a close relationship between this plant and *A. ochroleuca* and *A. albiflora* (cf. Vol. 5).²³⁰ Similarly, the presence of (–)-scoulerine and the benzophenanthridine norchelerythrine in *A. polyanthemus* confirms its close biochemical relationship with *A. albiflora*.²³¹

Two new alkaloids isolated from *Corydalis incisa* are suggested to be metabolites of coptisine.²³² The structure of the first, corydalispirone (117), was established by spectroscopy and by hydride reduction to give a mixture of bicucullinediol (118; R = *α*-OH) and adluminediol (118; R = *β*-OH). Alkaloid (117) contains a carbinolamine-like functional group, comparable in properties to that in corynoloxine. It undergoes reversible ring opening upon formation of the perchlorate (Scheme 9), and this process could account for the lack of optical activity in the isolated

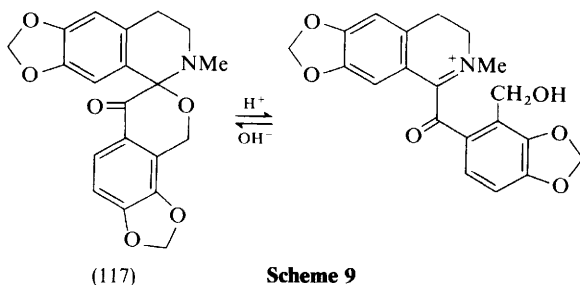

material. This structure has previously been postulated for the alkaloid hypecorinine of the same m.p. from *Hypecoum erectum* (cf. Vol. 4). The structure of the second new alkaloid from *C. incisa*, corydalisol (118; R = H), was established by its conversion into tetrahydrocoptisine.²³² The related aldehyde canadaline (119) is a new minor alkaloid isolated from *Hydrastis canadensis*.²³³



Mecambridine (120; R = Me) has been isolated from *Papaver pseudocanescens* together with alborne, which is possibly an artefact arising from aerial oxidation of (120; R = Me).^{143,144} A new alkaloid from this plant is (–)-mecambridine methohydroxide.¹⁴³ Full details of the total synthesis of (±)-mecambridine have

²³⁰ K. Haisova and J. Slavik, *Coll. Czech. Chem. Comm.*, 1975, **40**, 1576.

²³¹ K. Haisova and J. Slavik, *Coll. Czech. Chem. Comm.*, 1974, **39**, 2491.

²³² G. Nonaka and I. Nishioka, *Chem. and Pharm. Bull (Japan)*, 1975, **23**, 294.

²³³ J. Gleye, A. Ahond, and E. Stanislas, *Phytochemistry*, 1974, **13**, 675.

appeared.²³⁴ Orientalidine (121) has been prepared from demethylmecambridine (120; R = H) (Scheme 10). The acetal (122) was also synthesized.²³⁵

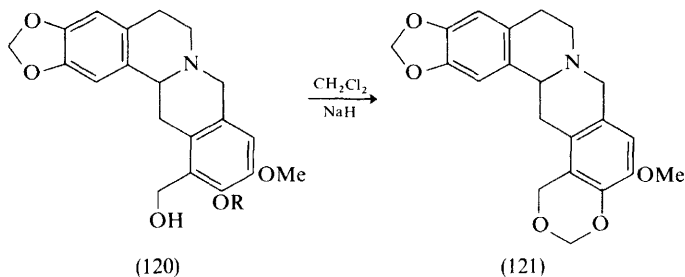

Scheme 10

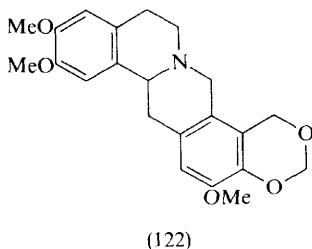

Details of the synthesis of berberastine *via* a 3-aryltetrahydroisoquinoline have appeared.²³⁶ In a new modification of this route, separable mixtures of scoulerine (123; R¹ = OH; R² = H) and coreximine (123; R¹ = H; R² = OH), stereospecifically labelled with tritium at C-13, have been synthesized from stereospecifically labelled α -tritiobenzyl alcohols (Scheme 11).²³⁷

Further studies have been carried out on the photocyclization of 2-aryl-1-methylene-tetrahydroisoquinolines (*cf.* Vol. 4). Under prepregassed conditions, 8-oxoberberine derivatives have been obtained in excellent yield.²³⁸ The modification of this photocyclization in which an *ortho*-methoxy- or halogeno-substituent is eliminated (*cf.* Vol. 5) has been further exploited, and it has been found that nitro- or methylthio-groups are also eliminated.²³⁹

The benzocyclobutene-dihydroisoquinoline condensation shown in Scheme 12 gave the quaternary protoberberine salt (124; R = H), the intermediate dihydro-derivative of this evidently losing hydrogen under the reaction conditions.²⁴⁰ This type of salt [*e.g.* (124, R = OMe)] and its dehydro-analogue can be obtained by Vilsmeier-Haack reactions of 1-benzyl-3,4-dihydroisoquinolines and 1-benzylisoquinolines, respectively. 1-Benzyltetrahydroisoquinolines did not react.²⁴¹

²³⁴ T. Kametani, A. Ujiie, and K. Fukumoto, *J.C.S. Perkin I*, 1974, 1954.

²³⁵ T. Kametani, A. Ujiie, M. Ihara, and K. Fukumoto, *Heterocycles*, 1975, **3**, 143.

²³⁶ S. F. Dyke and E. P. Tiley, *Tetrahedron*, 1975, **31**, 561.

²³⁷ A. R. Battersby, J. Staunton, H. R. Wiltshire, B. J. Bircher, and C. Fuganti, *J.C.S. Perkin I*, 1975, 1162.

²³⁸ G. R. Lenz, *J. Org. Chem.*, 1974, **39**, 2846.

²³⁹ G. R. Lenz, *J. Org. Chem.*, 1974, **39**, 2839.

²⁴⁰ T. Kametani, T. Kato, and K. Fukumoto, *Tetrahedron*, 1974, **30**, 1043.

²⁴¹ T. Kametani, M. Takeshita, F. Satoh, and K. Nyu, *Yakugaku Zasshi*, 1974, **94**, 478 (*Chem. Abs.*, 1974, **81**, 37 690).

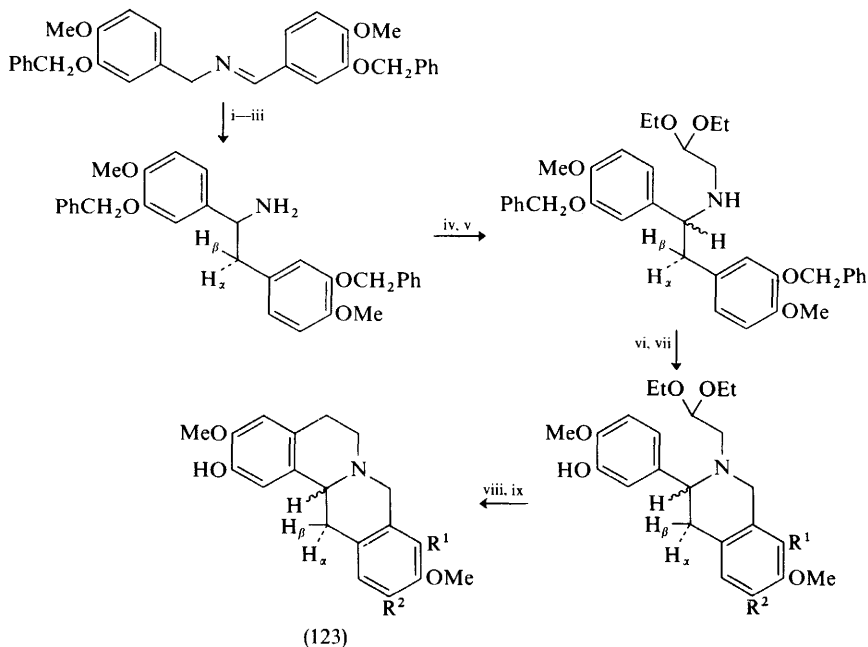

Reagents: i, NaH, DMF; ii, $\text{ArCH}_2\text{H}_2\text{Cl}$; iii, 2*N*-aq. HCl; iv, $\text{CHO}\cdot\text{CH}(\text{OEt})_2$; v, KBH_4 , MeOH; vi, 10% Pd/C, H_2 , EtOH, conc. HCl; vii, CH_2O , NaHCO_3 , aq. MeOH; viii, conc. HCl, overnight; ix, 10% Pd/C, H_2 , 10% HClO_4 in HOAc

Scheme 11

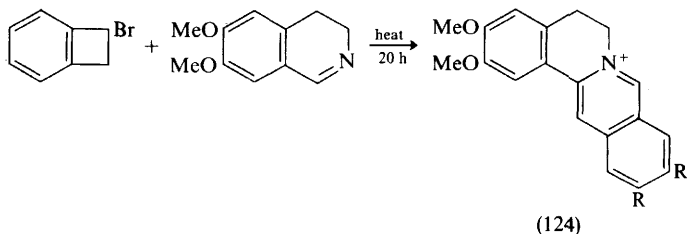

Scheme 12

Hofmann degradation of a number of phenolic tetrahydroberberines has been studied. Whereas discretine methiodide (125; $\text{R}^1 = \text{R}^3 = \text{H}$; $\text{R}^2 = \text{Me}$; $\text{R}^4 = \text{OMe}$) reacted with methanolic base to give only the normal methine (126), the C-9 phenols schefferine methiodide (125; $\text{R}^1 = \text{R}^2 = \text{Me}$; $\text{R}^3 = \text{OH}$; $\text{R}^4 = \text{H}$) and nandinine methiodide (125; $\text{R}^1 + \text{R}^2 = \text{CH}_2$; $\text{R}^3 = \text{OH}$; $\text{R}^4 = \text{H}$) and the C-11 phenol (125; $\text{R}^1 + \text{R}^2 = \text{CH}_2$; $\text{R}^3 = \text{H}$; $\text{R}^4 = \text{OH}$) also afforded the corresponding benzyltetrahydroisoquinoline (127).^{242,243} In the case of coreximine (125; $\text{R}^1 = \text{Me}$; $\text{R}^2 = \text{R}^3 = \text{H}$; $\text{R}^4 = \text{OH}$), which has a free phenolic grouping at C-2 as well as at C-11, the

²⁴² T. Kametani, M. Takemura, K. Fukumoto, T. Terui, and A. Kozuka, *Heterocycles*, 1974, 2, 433.

²⁴³ T. Kametani, M. Takemura, K. Fukumoto, T. Terui, and A. Kozuka, *J.C.S. Perkin I*, 1974, 2678.

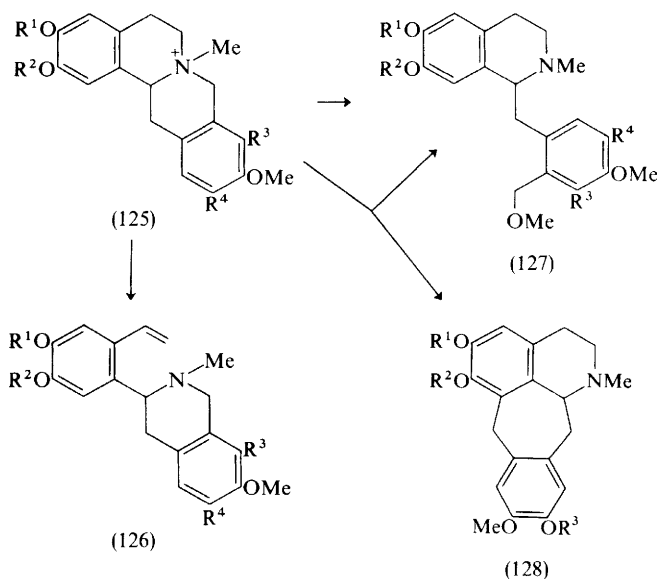

benzyltetrahydroisoquinoline formed was accompanied by the benzocycloheptyl derivative (128; $R^1 = Me$; $R^2 = R^3 = H$), the proportion of the latter increasing as the reaction time was extended.^{244,245} The structure of this was confirmed by synthesis of the dimethyl ether (128; $R^1 = R^2 = R^3 = Me$) from laudanosine. Quinone methides are considered to be intermediates in the formation of the above phenols (127) and (128), and a protonated quinone methide intermediate is postulated in the reaction of the benzyltetrahydroisoquinoline (127; $R^1 + R^2 = CH_2$; $R^3 = OH$; $R^4 = H$) with ethanolic HCl to give (128; $R^1 + R^2 = CH_2$; $R^3 = H$).

Tetrahydroberberinium iodide (125; $R^1 + R^2 = CH_2$; $R^3 = OMe$; $R^4 = H$) undergoes rearrangement to the spiro-indane (129) when treated with phenyl-lithium or

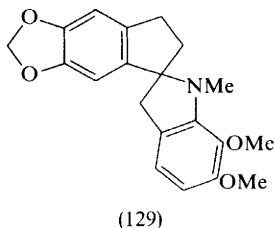

lithium aluminium hydride.²⁴⁶ The reaction of the homoprotoberberine salt (130) with sodium methylsulphinylmethanide afforded the dibenzazecine derivative (131), and (130) is thus probably an intermediate in the reaction of the bromo-compound

²⁴⁴ T. Kametani, M. Takemura, K. Takahashi, M. Takeshita, M. Ihara, and K. Fukumoto, *Heterocycles*, 1974, 2, 653.

²⁴⁵ T. Kametani, M. Takemura, K. Takahashi, M. Takeshita, M. Ihara, and K. Fukumoto, *J.C.S. Perkin I*, 1975, 1012.

²⁴⁶ Y. Kondo, T. Takemoto, and K. Kondo, *Heterocycles*, 1974, 2, 659.

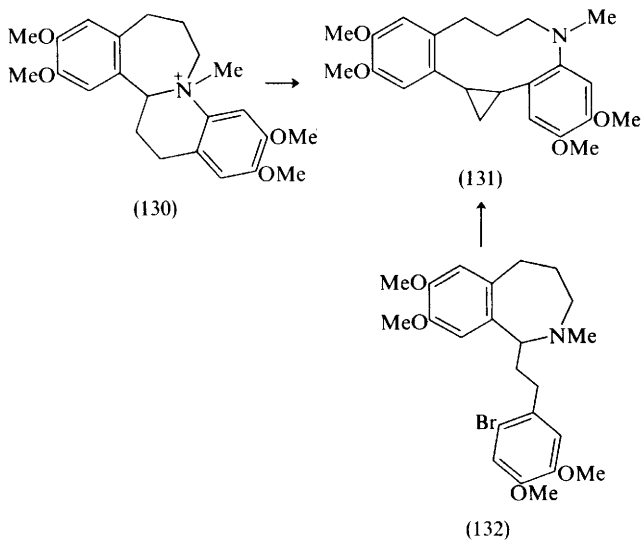

(132) to give (131).²⁴⁷ In connection with biosynthetic studies, stylophine has been degraded in separate sequences *via* phenyldihydrocoptisine (133; R = Ph) and benzyldihydrocoptisine (133; R = CH₂Ph).²⁴⁸

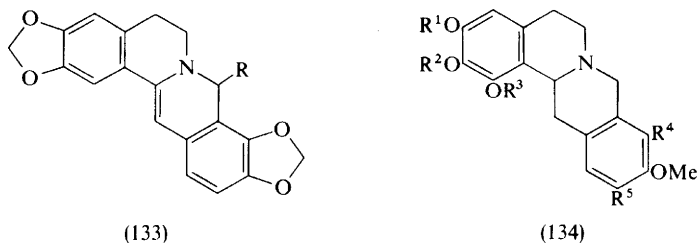

The preferred conformation of tetrahydroprotoberberines can be assigned from the chemical shift of C-6 in the ¹³C n.m.r. spectrum. This resonance appears upfield of 48.3 p.p.m. in the 1-methoxy-compounds, *e.g.* (134; R¹ + R² = CH₂; R³ = Me; R⁴ = H; R⁵ = OMe), where the preferred conformation is *cis*, and at *ca.* 51.3 p.p.m. in 1-unsubstituted compounds, where it is *trans*. On this basis, the preferred conformation of (134; R¹ = Me; R² + R³ = CH₂; R⁴ = H; R⁵ = OMe) was deduced to be *trans*, and supporting evidence was provided by the presence of strong Bohlmann bands in the i.r. It was suggested that chemical-shift values for C-8 may be used to distinguish 9,10- and 10,11-substituted tetrahydroprotoberberines.²⁴⁹

T.l.c. procedures for the separation of protoberberine alkaloids have been reviewed,²⁵⁰ and one involving the use of the BN continuous-flow chamber has been

²⁴⁷ S. Kano, T. Ogawa, T. Yokomatsu, T. Takahagi, E. Komiyama, and S. Shibuya, *Heterocycles*, 1975, **3**, 129.

²⁴⁸ A. R. Battersby, R. J. Francis, M. Hirst, E. A. Ruveda, and J. Staunton, *J.C.S. Perkin I*, 1975, 1140.

²⁴⁹ T. Kametani, A. Ujiie, M. Ihara, F. Fukumoto, and H. Koizumi, *Heterocycles*, 1975, **3**, 371.

²⁵⁰ T. Kamiewska, in 'Chromatografia Cienkowiarsztwa Analizie Farmaceutycznej', ed. B. Borkowski, Państwowy Zakład Wydawnictw Lekarskich, Warsaw, 1973, p. 191 (*Chem. Abs.*, 1975, **82**, 103 201).

described.¹⁶ Ion exchange has been recommended for quantitative determination of the alkaloids of *Berberis vulgaris*.²⁵¹ The alkaloids present in various organs of this plant have been studied²⁵² and the antibiotic activity of the total alkaloid content as well as of the individual alkaloids has been measured.²⁵³ The alkaloid extract was found to have toxic effects upon the seedlings of some woodland species.²⁵⁴ A method has been described for isolating berberine from *B. oblonga*.²⁵⁵ Accumulation of protoberberine and benzophenanthridine alkaloids in the vacuoles of the latex of *Chelidonium majus* has been studied.²⁵⁶

The *cis*- and *trans*-D- and -L-norcoralydine methiodides have been prepared and their neuromuscular blocking potentials measured.²⁵⁷ Homocoralyne (135), one of a

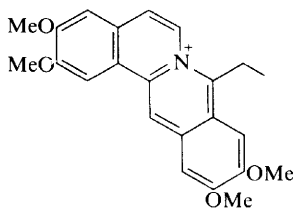

(135)

number of new analogues of coralyne, showed greater antileukaemic activity than the latter.²⁵⁸ The interaction of a number of berberine derivatives and protoberberine alkaloids with liver alcohol dehydrogenase has been studied, and the effects of structural variation upon the inhibitory power of such compounds have been discussed.²⁵⁹ The technique whereby nuclei and chromosomes are rendered fluorescent with berberine sulphate has been applied to plant^{260,261} as well as mammalian²⁶² systems and has been used for exfoliative cytodiagnosis of carcinoma cervix uteri.²⁶³

11 Protopine Alkaloids

Alkaloid isolation work is summarized in Table 7. Callus tissues from eleven species of the Papaveraceae (*e.g. Macleaya cordata*), known as sources of protopines, did

²⁵¹ M. Pilea, *Planta Med.*, 1975, **27**, 213.

²⁵² K. Drost-Karbowska, Z. Zowalewski, and M. Szauffer, *Acta Polon. Pharm.*, 1974, **31**, 683 (*Chem. Abs.*, 1975, **82**, 121 750).

²⁵³ E. Andronescu, P. Petcu, T. Goina, and A. Radu, *Clujul Medical*, 1973, **46**, 627 (*Chem. Abs.*, 1974, **81**, 100 062).

²⁵⁴ V. M. Oleksevich, *Introd. Eksp. Ekol. Rosl.*, 1972, **1**, 224 (*Chem. Abs.*, 1975, **82**, 52 393).

²⁵⁵ M. M. Tadzhibaev, I. N. Zatorskaya, K. L. Lutfullin, and T. T. Shakirov, *Khim. prirod. Soedinenii*, 1974, **48** (*Chem. Abs.*, 1974, **81**, 60 802).

²⁵⁶ B. P. Jans, *Ber. Schweiz. Bot. Gesellschaft*, 1974, **83**, 306 (*Chem. Abs.*, 1975, **82**, 82 951).

²⁵⁷ J. B. Stenlake, W. D. Williams, N. C. Dhar, R. D. Waigh, and I. G. Marshall, *European J. Med. Chem. Chim. Ther.*, 1974, **9**, 243.

²⁵⁸ K.-Y. Zee-Cheng, K. D. Paull, and C. C. Cheng, *J. Medicin. Chem.*, 1974, **17**, 347.

²⁵⁹ S. Pavelka and J. Kovar, *Coll. Czech. Chem. Comm.*, 1975, **30**, 753.

²⁶⁰ J. Moutschen, M. Moutschen-Dahmen, N. De Graeve, and J. Gilot-Delhalle, *Rev. Cytol. Biol. Veg.*, 1973, **36**, 357 (*Chem. Abs.*, 1974, **81**, 22 823).

²⁶¹ J. Moutschen, N. De Graeve, and M. Moutschen-Dahmen, *Cytobiologie*, 1973, **8**, 112.

²⁶² A. I. Khadzhilov, E. T. Svetkova, I. Vulkov, L. Gitsov, I. Cholakova, M. Marinov, and I. Tsvetkov, *Arch. Union Med. Balk.*, 1974, **12**, 53 (*Chem. Abs.*, 1975, **82**, 53 611).

²⁶³ A. I. Khadzhilov, E. T. Svetkova, E. M. Enchev, and K. G. Tsanev, *Doklady Bolg. Akad. Nauk.*, 1974, **27**, 1301 (*Chem. Abs.*, 1975, **82**, 71 314).

Table 7 Isolation of protopine alkaloids

Alkaloid(s)*	Species
A, P	<i>Argemone munita</i> subsp. <i>argentea</i> , ¹⁴² <i>A. polyanthemos</i> , ²³¹ <i>A. subintegrifolia</i> , ¹⁴² <i>Bocconia frutescens</i> , ²⁸⁵ <i>Corydalis koidzumiana</i> , ¹¹⁴ <i>Glaucium flavum</i> , ²⁷⁰ <i>G. fibrilligerum</i> , ¹¹⁶ <i>Macleaya cordata</i> , ²⁸⁵ <i>M. microcarpa</i> . ²⁸⁵
A, C, P	<i>A. mexicana</i> ²³⁰
C, P	<i>Papaver pseudocanescens</i> ¹⁴³
F, P, V	<i>Fumaria vaillantii</i> ²⁶⁴
P	<i>Corydalis marschalliana</i> , ^a <i>C. ochotensis</i> , ³⁰⁰ <i>C. sempervirens</i> , ²⁸⁸ <i>C. vaginans</i> , ²⁹⁹ <i>Eschscholtzia oregana</i> , ¹²¹ <i>Fumaria indica</i> , ^{228,229}
A†	<i>A. Mexicana</i> indigenous to Vietnam and grown in U.S.S.R. ^b

* A = allocryptopine, C = cryptopine, F = fumaridine, P = protopine, V = vaillantine; † Misprinted as allocryptopine in the English summary in reference b; ^a Kh. G. Kiryakov, I. A. Israelov, and S. Yu. Yunusov, *Khim. prirod. Soedinienii*, 1974, 411 (*Chem. Abs.*, 1975, **82**, 54 166); ^b Bui Thi Yu, *Farmatsiya (Moscow)*, 1974, **23**, 36 (*Chem. Abs.*, 1974, **81**, 60 863).

contain the alkaloids, although in smaller amounts than in redifferentiated plants.¹⁵² The new alkaloid vaillantine, which has been isolated from *Fumaria vaillantii*, has been shown from spectroscopic data and comparison with those of muramine to be 2,3-didemethylmuramine (136).²⁶⁴ The structures of fumaridine

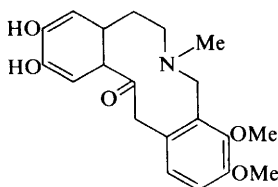

(136)

and fumaramine, which had previously been isolated from this plant (*cf.* Vol. 2), have now been revised, and they are now considered to be phthalide-isoquinoline derivatives rather than protopines (*cf.* Section 13).²⁶⁵

The 13-oxoprotuberberinium metho-salt (137) undergoes oxidative or reductive ring-scission reactions to give protopine analogues (Scheme 13).²⁶⁶ This provides a simple synthesis of 13-oxoallocryptopine (138; $R^1 + R^2 = CH_2$; $R^3 = O$), which has also been obtained by the action of mercuric acetate upon allocryptopine. The ketone (138; $R^1 + R^2 = CH_2$; $R^3 = H_2$) is the first member of a new group of 13-oxo-analogues of protopines. Transannular interaction of the carbonyl and amino-functions appears to be involved upon formation of the perchlorate of (138; $R^1 + R^2 = CH_2$; $R^3 = H_2$), the structure (139) being suggested by i.r. and ¹H n.m.r. evidence.²⁶⁶ This is contrary to the results expected from model studies.

²⁶⁴ M. U. Ibragimova, I. A. Israelov, M. S. Yunusov, and S. Yu. Yunusov, *Khim. prirod. Soedinienii*, 1974, 476 (*Chem. Abs.*, 1975, **82**, 28 586).

²⁶⁵ M. Shamma and J. L. Moniot, *J.C.S. Chem. Comm.*, 1975, 89.

²⁶⁶ B. Nalliah, R. H. F. Manske, and R. Rodrigo, *Tetrahedron Letters*, 1974, 1765.

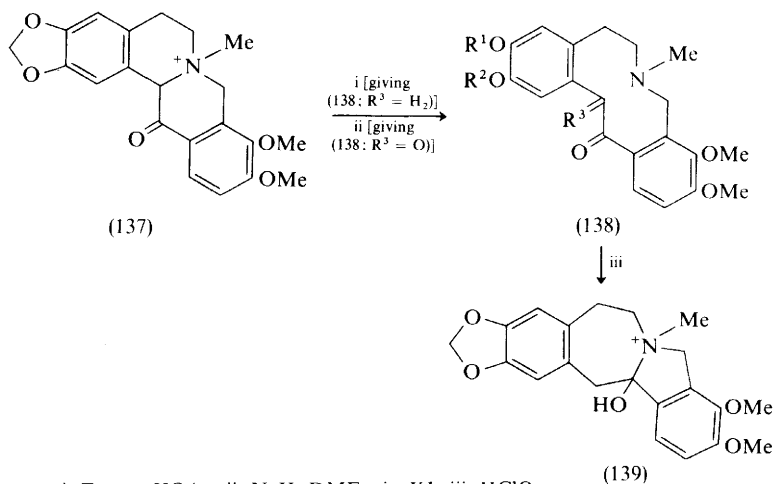

Scheme 13

12 Benzophenanthridine Alkaloids

Useful general syntheses of benzophenanthridines have been developed. This is illustrated by the synthesis of oxynitidine and oxyavicine *via* photocyclization of the

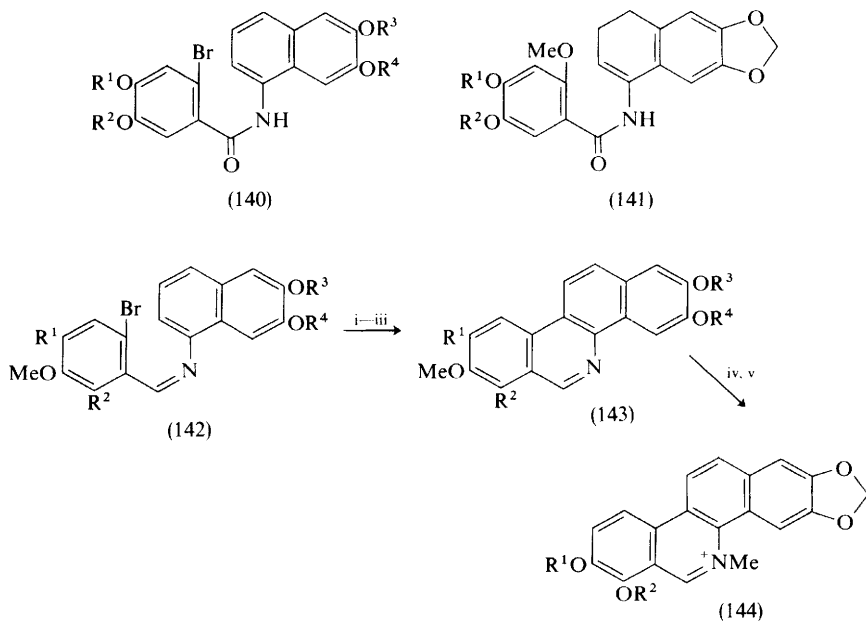

Scheme 14

appropriately substituted *o*-bromobenzoylnaphthylamine (140)²⁶⁷ or *o*-methoxybenzoylenamine (141).²⁶⁸ A new route used for the synthesis of chelerythrine chloride (144; R¹ = R² = Me) (Scheme 14) from the imine (142; R¹ = H; R² = OMe; R³ + R⁴ = CH₂) involves cyclization of a benzyne intermediate.²⁶⁹

Work on alkaloid isolation is summarized in Table 8. Bocconoline has been isolated from *Glaucium flavum*.²⁷⁰ The only known previous source was *Bocconia*

Table 8 Isolation of benzophenanthridine alkaloids

Species	Alkaloid	Ref.
<i>Argemone mexicana</i> ^{a,b}	Norchelerythrine,	} 230
	Norsanguinarine	
<i>A. polyanthemus</i> ^{a,b}	Norchelerythrine	231
<i>Corydalis incisa</i> ^c	11-Epicorynoline,	} 277
	12-Hydroxycorynoline,	
	6-Oxocorynoline	
<i>C. koidzumiana</i> ^a	Dihydrosanguinarine,	} 114
	Oxysanguinarine	
<i>C. sempervirens</i>	Oxysanguinarine	288
<i>C. vaginans</i>	Sanguinarine	299
<i>Fagara maju</i>	Chelerythrine	^e
<i>Glaucium fibrilligerum</i> ^{a,b}	Chelidonine	116
<i>G. flavum</i> ^{a,b}	Bocconoline,	} 270
	(-)-Chelidonine,	
	Chelirubine,	
	(-)-Norchelidonine	
<i>Papaver somniferum</i> ^d	Norsanguinarine	152
<i>Sanguinaria canadensis</i> ^{a,b}	Dihydrosanguilutine,	} 273
	Sanguilutine	
<i>Zanthoxylum avicennae</i> ^b	Avicine,	} 28
	Dihydroavicine,	
	Nitidine	
<i>Z. parvifoliotum</i> ^b	Nitidine	^f
<i>Z. rubescens</i>	Dihydrochelerythrine	^g
<i>Z. tsihanimposa</i>	<i>O</i> -Demethyl-6-dihydrochelerythrinyl acetone	} 281
	6-Dihydrochelerythrinyl acetaldehyde	
	6-Dihydrochelerythrinylacetone	
<i>Z. viride</i> ^b	Decarine,	} 282
	Nitidine	
<i>Z. decaryi</i>	Decarine	283

^a Sanguinarine also present; ^b Chelerythrine also present; ^c cf. also Vols. 3 and 4; ^d Callus tissues; ^e I. A. Benages, M. E. A. De Juarez, S. M. Albonica, A. Urzua, and B. K. Cassels, *Phytochemistry*, 1974, **13**, 2891; ^f F. Fish, A. I. Gray, and P. G. Waterman, *Phytochemistry*, 1975, **14**, 310; ^g F. Fish, A. I. Gray, and P. G. Waterman, *Planta Med.*, 1974, **25**, 281.

cordata (cf. Vol. 3). Also obtained from *G. flavum* were a number of previously isolated alkaloids, including chelirubine.²⁷⁰ The structure (145; R¹ + R² = R³ + R⁴ = CH₂) attributed to this alkaloid (cf. Vol. 4) has now been revised to (146; R¹ + R² = R³ + R⁴ = CH₂) as a result of the synthesis of the product of its oxidation by potassium

²⁶⁷ S. V. Kessar, G. Singh, and P. Balakrishnan, *Tetrahedron Letters*, 1974, 2269.

²⁶⁸ I. Ninomiya, T. Naito, H. Ishii, T. Ishida, M. Ueda, and K. Harada, *J.C.S. Perkin I*, 1975, 762.

²⁶⁹ S. V. Kessar, G. Singh, and P. Balakrishnan, *Indian J. Chem.*, 1974, **12**, 323.

²⁷⁰ V. Novak and J. Slavik, *Coll. Czech. Chem. Comm.*, 1974, **39**, 3352.

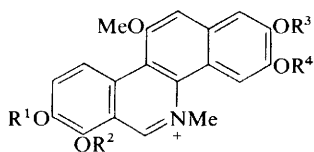

(145)

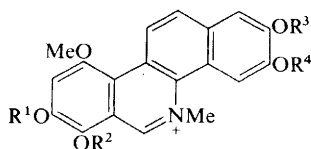

(146)

ferricyanide oxidation [oxochelirubine (147)] by the enamide photocyclization route (Scheme 15).²⁷¹ It seems likely that the structures of chelilutine, sanguirubine, and sanguilutine, which co-occur with chelirubine in *Sanguinaria canadensis* and to

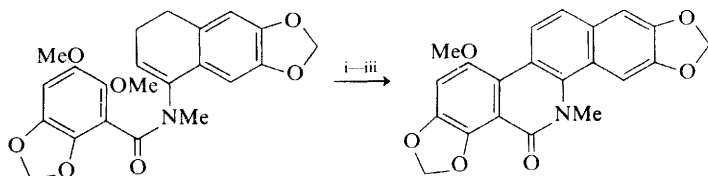

(147)

Reagents: i, $h\nu$; ii, conc. HCl; iii, 30% Pd/C, *p*-cymene

Scheme 15

which have been attributed 9-methoxy-structures of the type (145), should be revised to (146; $R^1 = R^2 = \text{Me}$; $R^3 + R^4 = \text{CH}_2$), (146; $R^1 + R^2 = \text{CH}_2$; $R^3 = R^4 = \text{Me}$), and (146; $R^1 = R^2 = R^3 = R^4 = \text{Me}$), respectively, in view of the close spectroscopic similarities of the four alkaloids.²⁷² The new alkaloid dihydrosanguilutine has now been isolated from this plant and converted into sanguilutine by oxidation with mercuric acetate.²⁷³ The structure assigned to the new alkaloid, based on the previously accepted 9-methoxy-structure for sanguilutine, should probably be revised to (148).

The structure of the antileukaemic alkaloid fagaronine (149) has been confirmed by spectral studies on its pyrolysis product, the *N*-demethyl compound (143;

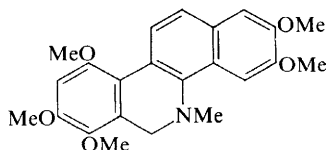

(148)

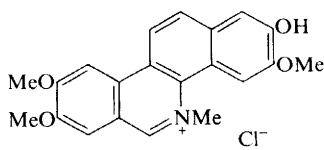

(149)

$R^1 = \text{OMe}$; $R^2 = R^3 = \text{H}$; $R^4 = \text{Me}$).²⁷⁴ The latter has been synthesized *via* photocyclization of the naphthylamide (140; $R^1 = R^2 = R^4 = \text{Me}$; $R^3 = \text{Ac}$).²⁷⁵ The alkaloid itself has been synthesized from (142; $R^1 = \text{OMe}$; $R^2 = \text{H}$; $R^3 = \text{CHMe}_2$; $R^4 = \text{Me}$) by the benzyne cyclization route.²⁷⁶

²⁷¹ H. Ishii, K. Harada, T. Ishida, E. Ueda, and K. Nakajama, *Tetrahedron Letters*, 1975, 319.

²⁷² J. Slavik, L. Dolejs, V. Hanus, and A. D. Cross, *Coll. Czech. Chem. Comm.*, 1968, **33**, 1619; L. Hruban, F. Santavy, and S. Hegerova, *Coll. Czech. Chem. Comm.*, 1970, **35**, 3420.

²⁷³ D. K. Kim and F. R. Stermitz, *Phytochemistry*, 1975, **14**, 834.

²⁷⁴ M. Tinwa, C. L. Bell, C. Bevelle, H. H. S. Fong, and N. R. Farnsworth, *J. Pharm. Sci.*, 1974, **63**, 1476.

²⁷⁵ I. Ninomiya, T. Naito, and H. Ishii, *Heterocycles*, 1975, **3**, 307.

²⁷⁶ J. P. Gillespie, L. G. Amoros, and F. R. Stermitz, *J. Org. Chem.*, 1974, **39**, 3239.

Two new minor alkaloids isolated from *Corydalis incisa*, along with the lactam oxycorynoline (150), are 12 β -hydroxycorynoline (151; R¹+R²=CH₂; R³=OH) and 11-epicorynoline (152). These structures were established by spectroscopy and by chemical correlation with derivatives of corynoline. Two routes, for instance, were found from the latter to 12 β -hydroxycorynoline (151) and its 12 α -epimer.²⁷⁷ (+)-14-Epicorynoline has the absolute stereochemistry depicted in (153), as shown

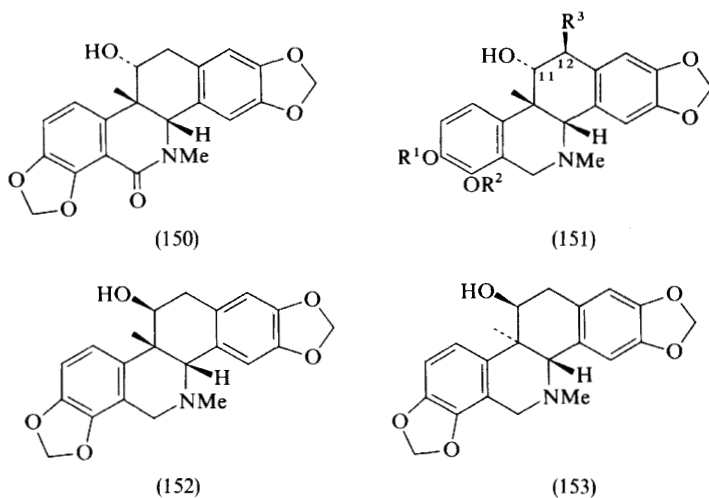

by an X-ray study of its bromoacetate.²⁷⁸ Features revealed were the *trans* B/C ring junction, with rings B and C in half-chair and twisted half-chair conformations, respectively. The alcoholic hydroxy-group is in an axial position.²⁷⁸ Full details of the synthesis of the corynoline analogue (151; R¹=R²=Me; R³=H) via a styryl-1,2-dihydroisoquinoline derivative have appeared (cf. Vols. 2 and 5).^{279,280}

Two new products isolated from *Zanthoxylum tsihanimposa*, together with 6-dihydrochelerythrinylacetone, have been formulated as 6-dihydrochelerythrinylacetaldehyde (154; R¹=R²=Me; R³=CH₂CHO) and an *O*-demethyl-6-dihydrochelerythrinylacetone (154; R¹=H; R²=Me; R³=CH₂COMe) or (154; R¹=Me; R²=H; R³=CH₂COMe). If these compounds are artefacts, the isolation of the last compound would suggest that the plant contains an *O*-demethylchelerythrine, the position of the phenolic grouping in which remains to be

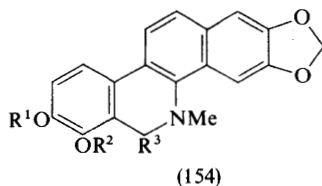

²⁷⁷ G. Nonaka and I. Nishioka, *Chem. and Pharm. Bull (Japan)*, 1975, **23**, 521.

²⁷⁸ N. Takao, M. Kamiguchi, K. Iwawa, K. Tomita, T. Fujiwara, and A. Wakahara, *Tetrahedron Letters*, 1974, 805.

²⁷⁹ M. Onda, K. Yuasa, and J. Okada, *Chem. and Pharm. Bull (Japan)*, 1974, **22**, 2365.

²⁸⁰ M. Onda, K. Abe, M. Gotoh, K. Kataoka, K. Yuasa, and J. Okada, *Heterocycles*, 1975, **3**, 96.

determined.²⁸¹ The two possible *O*-demethylchelerythrines are fagaridine (144; $R^1 = \text{Me}$; $R^2 = \text{H}$) and decarine metho-salt (144; $R^1 = \text{H}$; $R^2 = \text{Me}$), the iodides of which have recently been compared in the course of investigating the structure of decarine isolated from the bark of *Z. viride*.²⁸² Decarine has also been isolated from its conversion into norchelerythrine with diazomethane, together with the observation of a NOE between the methoxy-group and the *peri* imino-hydrogen at C-6.²⁸³

Whereas eleven species of plants of the Papaveraceae and redifferentiated plantlets showed specific alkaloid patterns, callus tissues were all similar in alkaloid content.¹⁵² Although norsanguinarine was not present in the original plants, it was the major alkaloid in callus tissues of *Papaver somniferum*, where it was found together with oxsanguinarine, dihydrosanguinarine, and sanguinarine. These alkaloids were all present in callus tissues of *Eschscholtzia californica*, *Macleaya cordata*, *P. setigerum*, *P. bracteatum*, *P. orientale*, *P. rhoeas*, *Dicentra peregrina*, *Corydalis incisa*, and *C. pallida*, and callus tissues from *Chelidonium japonica* and *Peridophyllum racemosum* contained all these alkaloids except sanguinarine. Chelirubine was detected only in the callus tissues of *E. californica*, *M. cordata*, and *P. bracteatum*.¹⁵²

The equilibrium between sanguinarine acetate and chelerythrine acetate and the corresponding 6-acetoxydihydro-tautomers has been studied by ¹H n.m.r. and u.v. spectroscopies.²⁸⁴

Reports have appeared on t.l.c. methods of detection of benzophenanthridine alkaloids in *Bocconia frutescens*, *Macleaya microcarpa*, and *M. cordata*²⁸⁵ and in *Fumaria capreolata*.²⁸⁶ A colorimetric method of determining the alkaloids in *B. cordata* has been described.²⁸⁷

13 Phthalideisoquinoline Alkaloids

Work on alkaloid isolation is summarized in Table 9. Fumaridine has been isolated, together with four known phthalideisoquinoline alkaloids, from *Fumaria vaillantii*.²⁶⁴ This compound and fumaramine (*cf.* Vol. 2) have now been shown to be the imide (155; $R^1 = R^2 = \text{Me}$), known as 'hydrastine imide', and its analogue (155; $R^1 + R^2 = \text{CH}_2$), obtainable by the action of hot concentrated NH_4OH upon ($-$)- β -hydrastine methiodide and bicuculline methiodide, respectively.²⁶⁵ The possibility that these compounds and narceine imide (*cf.* Vol. 3) are artefacts arising from quaternary phthalideisoquinolines (156) has been considered.²⁶⁵ The lactone (157; $R^1 = \text{H}$; $R^2 + R^3 = \text{CH}_2$), together with adlumidicine and adlumiceine (*cf.* Vol. 5), has been isolated from *Corydalis sempervirens*.²⁸⁸ The analogous lactone (157; $R^1 = R^2 = R^3 = \text{OMe}$) was obtained by Hofmann degradation of narcotine.

²⁸¹ N. Decaudain, N. Kunesch, and J. Poisson, *Phytochemistry*, 1974, **13**, 505.

²⁸² P. G. Waterman, *Phytochemistry*, 1975, **14**, 843.

²⁸³ J. Vaquette, J. L. Poussset, R. R. Paris, and A. Cavé, *Phytochemistry*, 1974, **13**, 1257.

²⁸⁴ O. N. Tolkachev and O. E. Lasskaya, *Khim. prirod. Soedinenii*, 1974, 741 (*Chem. Abs.*, 1975, **82**, 171 254).

²⁸⁵ W. Vent, *Acta Bot.*, 1973, **19**, 385.

²⁸⁶ J. Susplugas, S. El Nouri, V. Massa, and P. Susplugas, *Trav. Soc. Pharm. Montpellier*, 1974, **34**, 115 (*Chem. Abs.*, 1975, **82**, 28 500).

²⁸⁷ G. A. Maslova, *Khim. prirod. Soedinenii*, 1974, **10**, 261 (*Chem. Abs.*, 1974, **81**, 74 303).

²⁸⁸ V. Preininger, J. Vesely, O. Gasic, V. Simanek, and L. Dolejs, *Coll. Czech. Chem. Comm.*, 1975, **40**, 699.

Table 9 Isolation of phthalideisoquinoline alkaloids

Species	Alkaloid	Ref.	
<i>Corydalis marschalliana</i>	(-)-Adlumidine, (+)-Bicuculline	c c	
<i>C. ochotensis</i>	Adlumidine	300	
<i>C. sempervirens</i>	Adlumiceine, Adlumiceine, (-)-Adlumine, Bicuculline, Capnoidine, Lactone (157; R = H)	}	
<i>Fumaria indica</i> ^a	(±)-Bicuculline, (+)-Bicuculline		288
<i>F. vaillantii</i>	(-)-Adlumidine, (-)-Adlumine, (+)-Bicuculline		229
	Fumaramine	264	
	Fumaridine (Hydrastine imide)	265	
<i>Hydrastis canadensis</i>	(+)- α -Hydrastine	264,265	
<i>Papaver somniferum</i> ^b	(-)- α -Hydrastine	264	
	Narcotine	233	
		10	

^a The isolation of alkaloids named fumariline, fumarilicine, and narceimine has also been reported;
^b Stamens; ^c cf. Table 7, ref. a.

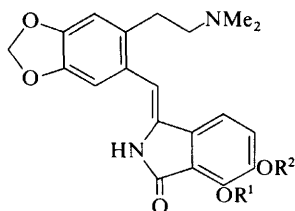

(155)

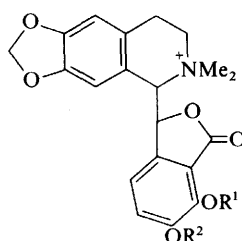

(156)

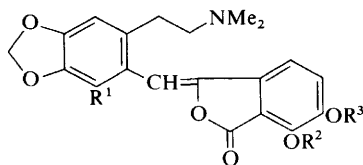

(157)

Thermal decomposition of narceine imide methoxyhydroxide (158) affords a mixture of (*Z*)- and (*E*)-narceone imides (159) together with a smaller amount of the dibenzyl dibenzopyrrocoline derivative (160). Cyclization of the narceone imides (159) in acid gave (160) (cf. Scheme 16) while cyclization in an alkaline medium gave the previously reported benzazepine derivative (161) (cf. Vol. 5).²⁸⁹ The structure of anhydro-*N*-oxynarceine (162; R¹ = H; R² = OMe), which is obtained by refluxing

²⁸⁹ J. Trojanek, Z. Kobicova, Z. Vesely, V. Suchan, and J. Holubek, *Coll. Czech. Chem. Comm.*, 1975, **40**, 681.

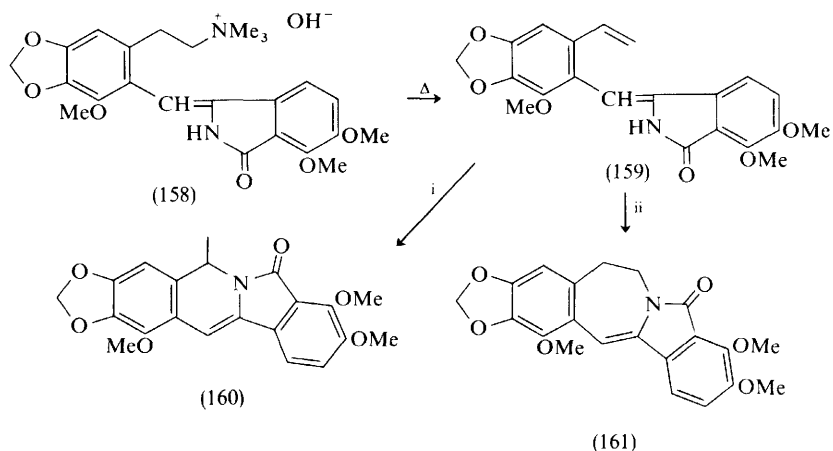

Reagents: i, HCl, aq. MeOH; ii, 30% aq. KOH

Scheme 16

α -narcotine oxide in chloroform, has been established by *X*-ray crystallography of the bromo-derivative (162; $R^1 = \text{Br}$; $R^2 = \text{OMe}$).²⁹⁰ Under similar conditions, β -hydrastine oxide afforded a mixture of (162; $R^1 = R^2 = \text{H}$) and the (*Z*)-enol lactone (163).

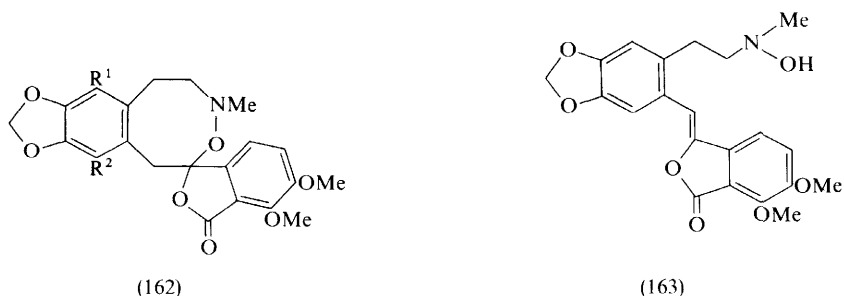

The *erythro*- and *threo*-isomers (165; $R = \text{H}$) and (166; $R = \text{H}$) and the corresponding *N*-methyl derivatives (165; $R = \text{Me}$) and (166; $R = \text{Me}$) have been prepared by a three-stage synthesis from 2'-hydroxymethylpapaverine (164) (Scheme 17).²⁹¹ The availability of these pairs of diastereoisomers allowed a detailed analysis of the conformations of the phthalisoquinolines in terms of shielding effects in the n.m.r. to be carried out. It was deduced that, in the preferred conformation of the *N*-nor-compounds, ring C lies close to the secondary nitrogen atom [*cf.* (167) and (169).] In the preferred conformations of the *N*-methyl compounds, rings C and D are found to be away from the nitrogen atoms. These rings lie in the vicinity of and

²⁹⁰ W. Klötzer and W. E. Oberhaensli, *Helv. Chim. Acta*, 1973, **56**, 2107.

²⁹¹ M. Shamma and V. St. Georgiev, *Tetrahedron Letters*, 1974, 2339.

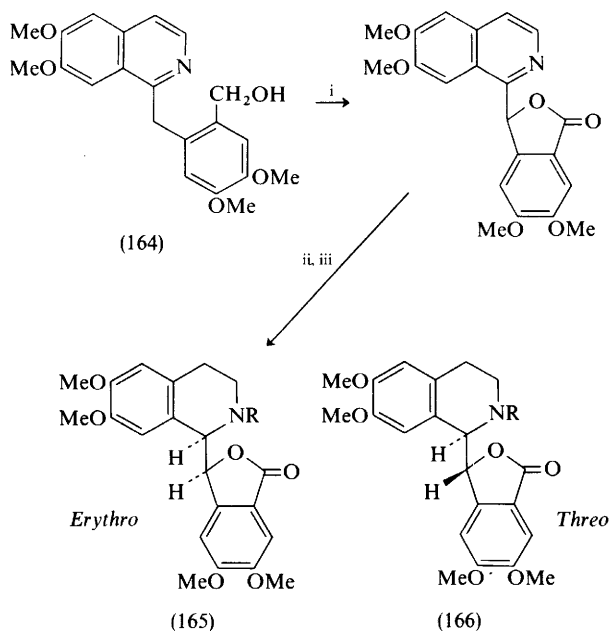

Reagents: i, CrO₃, HOAc, H₂SO₄; ii, PtO₂, acid, H₂; iii, HCHO, NaBH₄

Scheme 17

remote from ring A in the *erythro*- and *threo*-*N*-methyl compounds (168) and (170), respectively. The presence of an 8-methoxy function in the *erythro*-alkaloid narcotine forces the molecule into a (167)-type preferred conformation.²⁹¹

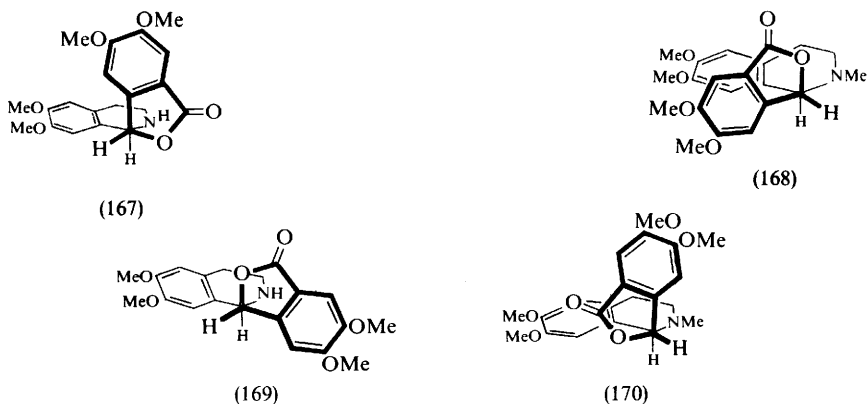

The *erythro*-phthalideisoquinoline (165; R = Me) has also been synthesized from the papaveraldine derivative (171) (Scheme 18).^{292,293}

²⁹² T. Kametani, S. Hirata, F. Satoh, and K. Fukumoto, *J.C.S. Perkin I*, 1974, 2509.

²⁹³ T. Kametani, S. Hirata, M. Ihara, and K. Fukumoto, *Heterocycles*, 1975, 3, 405.

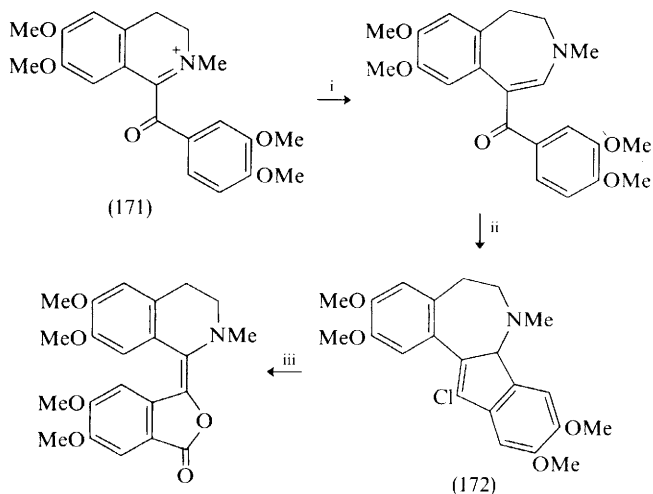

Reagents: i, CH_2N_2 ; ii, POCl_3 , toluene; iii, KMnO_4 , piperidine, HOAc ; iv, NaBH_4

Scheme 18

14 Rhoeadine and Papaverrubine Alkaloids

Papaverrubines C, D, and E have been isolated from *Papaver pseudocanescens*, and the presence of rhoeadine in the plant has been demonstrated.¹⁴⁴

The papaverrubine-type compound (173; $\text{R}^1 + \text{R}^2 = \text{CH}_2$; $\text{R}^3 = \text{R}^4 = \text{Me}$; $\text{R}^5 = \text{H}$) has been synthesized from (-)-hydrastine by a route similar to that used in the

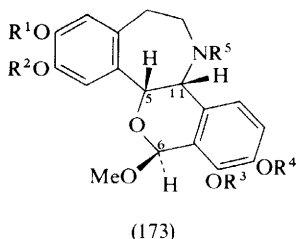

synthesis of (+)-rhoeadine (*cf.* Vol. 3).²⁹⁴ The biogenetically patterned conversion of 13-oxoprotoberberinium metho-salts into rhoeadines has formally been completed.²⁹⁵ The initial transformation into 13-oxoprotopine derivatives, *e.g.* (138; $\text{R}^1 + \text{R}^2 = \text{CH}_2$; $\text{R}^3 = \text{H}_2$), is described in Section 11. These have been converted (*cf.* Scheme 19) into benzindeno-azepines, one of which (174; $\text{R}^1 = \text{R}^2 = \text{Me}$) has previously been used in a synthesis of *cis*-alpinigenine (173; $\text{R}^1 = \text{R}^2 = \text{R}^3 = \text{R}^4 = \text{R}^5 = \text{Me}$) (*cf.* Vol. 5).²⁹⁵ The synthesis of the benzindano-azepine (172) from a papaveraldine derivative is described in Section 13. Benzindanoazepines of the type

²⁹⁴ R. Hohlbrugger and W. Klötzer, *Chem. Ber.*, 1974, **107**, 3457.

²⁹⁵ B. Nalliah, R. H. Manske, and R. Rodrigo, *Tetrahedron Letters*, 1974, 2853.

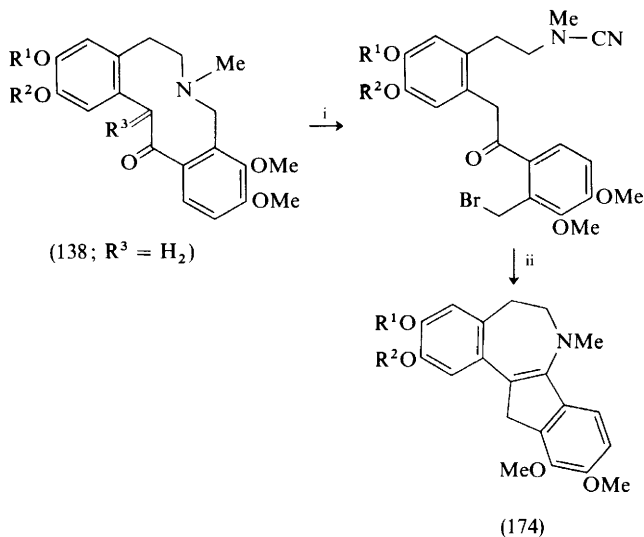

Reagents: i, $CNBr$, THF; ii, KOH , EtOH, reflux

Scheme 19

(175; $R = \beta$ -H) and (175; $R = \alpha$ -H) are readily obtained from spiro-isoquinolines (176) (Scheme 20).²⁹⁶

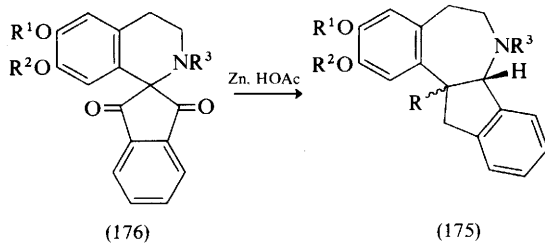

Scheme 20

Earlier work on the configuration of rheoadine alkaloids has been clarified (*cf.* Vol. 4) and isorhoeadine has been assigned the absolute configuration $5S,11R,6S$.^{297,298} The products (177; $R = OMe$) and (178), obtained by Emde degradation of the methiodides of rheoadine (173; $R^1 + R^2 = R^3 + R^4 = CH_2$; $R^5 = Me$) and isorhoeadine, had mirror-image c.d. curves, but are nevertheless considered, on spectroscopic grounds, to be diastereoisomers. The effect of the methoxy-group on the c.d. curves is considered to be negligible, and this was borne out by the virtual identity of the c.d. curves of (177; $R = OMe$) and (177; $R = H$). Emde

²⁹⁶ T. Kametani, S. Hirata, S. Hibino, H. Nemoto, M. Ihara, and K. Fukumoto, *Heterocycles*, 1975, 3, 151.

²⁹⁷ V. Simanek, A. Klasek, L. Hruban, V. Preininger, and F. Santavy, *Tetrahedron Letters*, 1974, 2171.

²⁹⁸ V. Simanek, L. Hruban, V. Preininger, A. Nemeckova, and A. Klasek, *Coll. Czech. Chem. Comm.*, 1975, 40, 705.

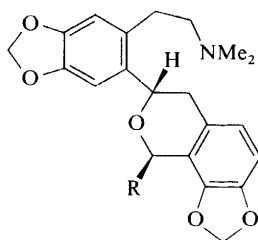

(177)

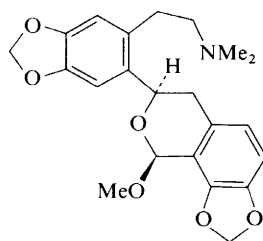

(178)

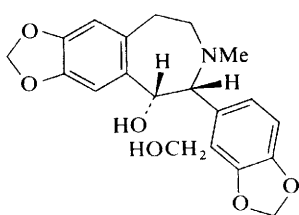

(179)

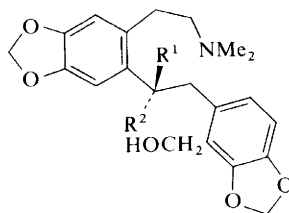

(180)

degradation of the methiodides of rhoeaginediol (179) and isorhoeaginediol, on the other hand, afforded (180; $R^1 = H$; $R^2 = OH$) and (180; $R^1 = OH$; $R^2 = H$), respectively, which were spectroscopically identical although having mirror-image c.d. curves and equal optical rotations of opposite sign. The two series of alkaloids thus differ only in configuration at C-5.^{297,298}

15 Spirobenzylisoquinoline Alkaloids

(+)-Ochrobirine has been identified among the alkaloids of *Corydalis vaginans*.²⁹⁹ The isolation of fumariline from *Fumaria indica* has been reported.²²⁹ The new alkaloids yenusomine (181) and yenusomidine (182) have been isolated, along with ochotensimine, from *Corydalis ochotensis*.³⁰⁰ The isolation and properties of the alkaloid corydalispirone [hypecorinine (117)] are discussed in Section 10.

The indanone (183; $R^1 = R^2 = Me$), from which the rhoeadine alkaloid *cis*-alpinigenine has been synthesized (*cf.* Vol. 5), and its analogue (183; $R^1 + R^2 = CH_2$)

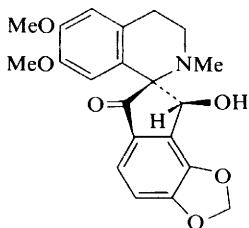

(181)

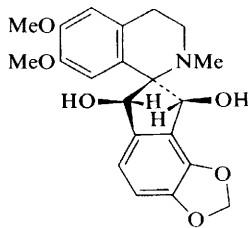

(182)

²⁹⁹ N. N. Margvelashvili, O. E. Laskaya, A. T. Kiryanova, and O. N. Tolkachev, *Khim. prirod. Soedinenii*, 1974, 813 (*Chem. Abs.*, 1975, **82**, 121 675).

³⁰⁰ S. T. Lu, T. L. Su, T. Kametani, and M. Ihara, *Heterocycles*, 1975, **3**, 301.

have been converted into the spiro-indanones (184; $R^1=R^2=Me$) and (184; $R^1+R^2=CH_2$) (Scheme 21). Since the latter has previously been converted into ochotensimine (*cf.* Vol. 1), this constitutes a new synthesis of this alkaloid.³⁰¹ The previously reported route from these indanones (183) to the enamino-ketones (185) (*cf.* Vol. 5) has been extended (*cf.* Scheme 21) to afford ochrobirine–yenusimine-type bases (186).³⁰¹

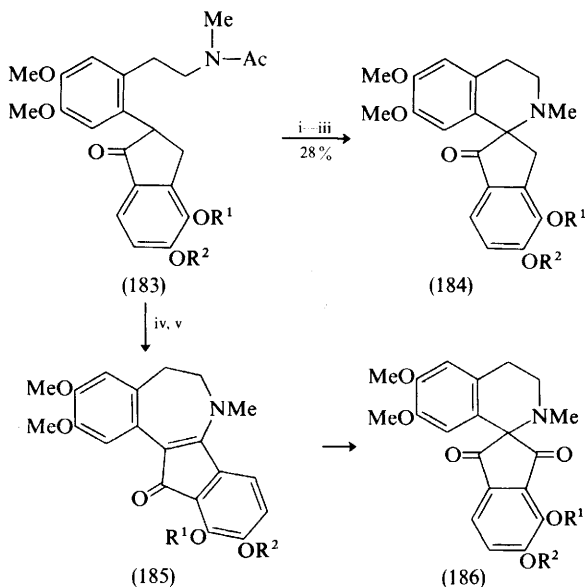

Reagents: i, 2*N*-aq. HCl; ii, Br_2 , HOAc, NaOAc; iii, Et_3N ; iv, KOH, EtOH, H_2O ; v, Triton B, pyridine, O_2 ; vi, 4*N*-aq. HCl; vii, Br_2 , HOAc

Scheme 21

Although the hydrochloride of the base (187; $R = H$) is stable at room temperature in organic solvents, the free base in chloroform undergoes aerial oxidation to (187; $R = OH$) followed by rearrangement to the spiro-indanone (188; $R^1 = H$; $R^2 = O$) in 64% yield. A mechanism has been proposed, similar to that for the thermal



³⁰¹ S. O. De Silva, K. Orito, R. H. F. Manske, and R. Rodrigo, *Tetrahedron Letters*, 1974, 3243.

rearrangement of the methiodide of (187; R = Me) to (188; R¹ = Me; R² = CH₂) (cf. Vols. 4 and 5).^{302,303}

16 Ipecacuanha Alkaloids

The tricyclic base (–)-(189), which is a key intermediate in the synthesis of various ipecacuanha alkaloids, has been synthesized from (+)-(190), the ethyl ester of cincholoopin (Scheme 22).³⁰⁴

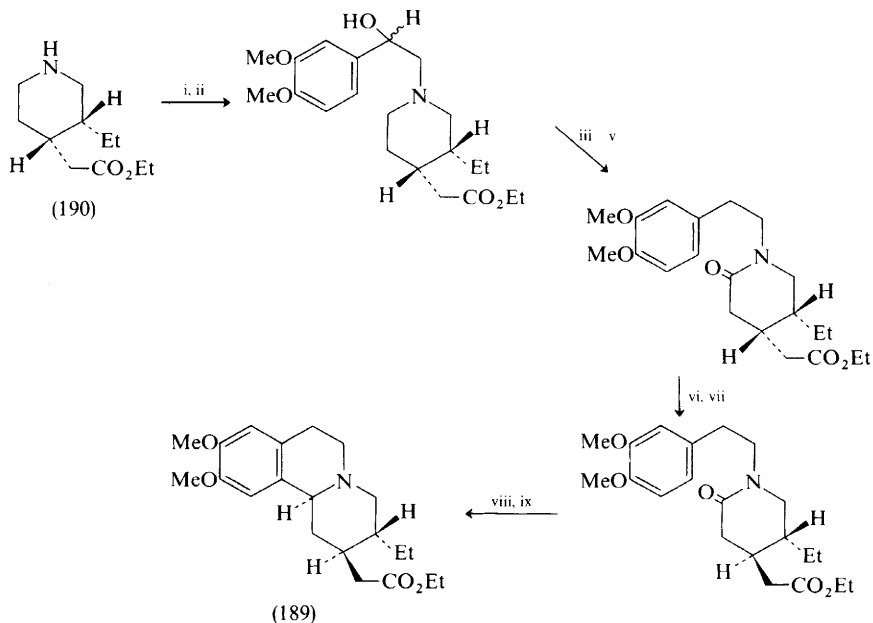

Reagents: i, 3,4-dimethoxyphenacyl chloride, K₂CO₃, benzene; ii, NaBH₄, EtOH; iii, Hg(OAc)₂, edta, 1% aq. HOAc; iv, Pd/C, H₂, EtOH, 70% aq. HClO₄; v, 1N-NaOH, EtOH, 20 °C; vi, 10% HCl, boiling; vii, EtOH, HCl, 25 °C; viii, POCl₃, toluene; ix, PtO₂, H₂, EtOH

Scheme 22

Synthesis of the four possible racemic forms of the base (191; R¹ = OH; R² = H) showed that none was identical with the alkaloid ankorine. Accordingly, the

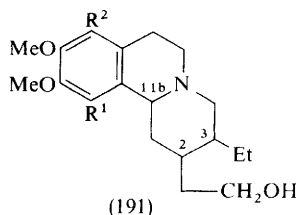

³⁰² T. Kametani, H. Takeda, Y. Hirai, F. Satoh, and K. Fukumoto, *J.C.S. Perkin I*, 1974, 2141.

³⁰³ T. Kametani, Y. Hirai, H. Takeda, M. Kajiwara, T. Takahashi, F. Satoh, and K. Fukumoto, *Heterocycles*, 1974, **2**, 339.

³⁰⁴ T. Fujii and S. Yoshifuji, *Tetrahedron Letters*, 1975, 731.

structure of the latter was revised to (191; $R^1 = H$; $R^2 = OH$) and tentatively assigned 11bH α , 2H α , 3H β relative stereochemistry [*i.e.* as in (193)] from mass spectral studies.³⁰⁵ This was borne out by a synthesis of (\pm)-ankorine from the lactam (192) (Scheme 23).³⁰⁶ Synthesis of (-)-ankorine by the cincholoipin ethyl ester route also

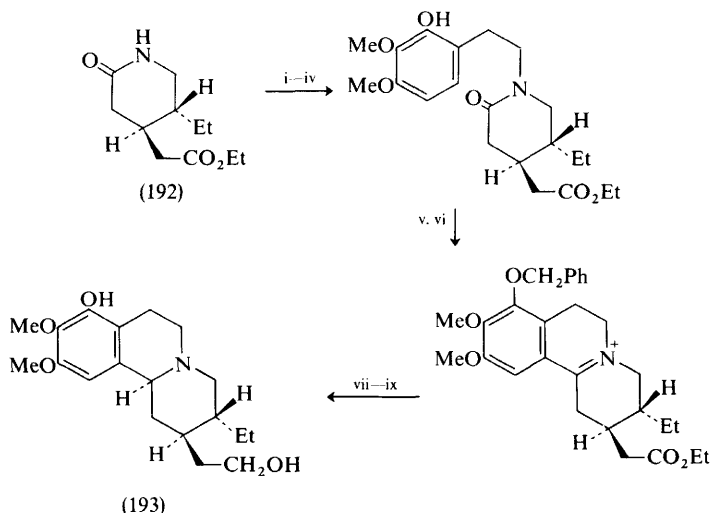

Reagents: i, $Et_3O^+ BF_4^-$; ii, 2-benzyloxy-3,4-dimethoxyphenacyl bromide; iii, $NaBH_4$; iv, Pd/C, H_2 , EtOH, 70% aq. $HClO_4$; v, $PhCH_2Br$, K_2CO_3 , acetone; vi, $POCl_3$, toluene; vii, Pt, H_2 , EtOH; viii, $LiAlH_4$; ix, Pd/C, H_2 , EtOH

Scheme 23

confirmed the absolute stereochemistry indicated by (193).³⁰⁷ It is now considered likely that the hydroxy-group in two other *A. lamarckii* alkaloids, alangicine and alangimarckine, should be located at C-8 rather than C-11,^{305,306} and that they should have the same relative and absolute stereochemistries at C-11, C-2, and C-3 as ankorine and the emetine alkaloids.³⁰⁶ Additional chemical data on deoxytubulosine and alangimarckine have been published.³⁰⁸

The synthesis of benzoquinolizine derivatives by phenolic cyclization has been reported.³⁰⁹

Emetine has been isolated from a number of varieties of *Hedera helix* growing in Egypt.^{310,311} Separation of emetine-type alkaloids by t.l.c.^{312,313} and a method of spectrophotometric estimation³¹³ have been described.

³⁰⁵ C. Szantay, E. Szentirmay, and L. Szabo, *Tetrahedron Letters*, 1974, 3725.

³⁰⁶ T. Fujii, S. Yoshifuji, and S. Kamada, *Tetrahedron Letters*, 1975, 1527.

³⁰⁷ S. Yoshifuji and T. Fujii, *Tetrahedron Letters*, 1975, 1965.

³⁰⁸ J. R. Merchant and S. S. Salgar, *Indian J. Chem.*, 1975, **13**, 100.

³⁰⁹ T. Kametani, K. Kigasawa, M. Hiiragi, H. Ishimaru, and S. Haga, *J. Heterocyclic Chem.*, 1974, **11**, 1023.

³¹⁰ G. H. Mahran and S. H. Hilal, *Egypt J. Pharm. Sci.*, 1972, **13**, 321 (*Chem. Abs.*, 1974, **81**, 169 679).

³¹¹ G. H. Mahran, S. H. Hilal, and T. S. El-Alfy, *Planta Med.*, 1975, **27**, 127.

³¹² M. Sobiczewska, in ref. 250, p. 186 (*Chem. Abs.*, 1975, **82**, 103 199).

³¹³ M. S. Habib, *Planta Med.*, 1975, **27**, 294.

17 Dimeric Benzylisoquinoline Alkaloids

Work on alkaloid isolation is summarized in Table 10. The alkaloid baluchistanamine (195; R = H), isolated from *Berberis baluchistanica*, is presumably formed

Table 10 Isolation of dimeric benzylisoquinoline alkaloids

Source	Alkaloid (Structure)	Ref.
<i>Berberis baluchistanica</i>	Baluchistanamine (195; R = H),	} 85
	Obaberine (194; R ¹ = R ² = Me; 1-S, 1'-R)	
	Oxyacanthine (194; R ¹ = Me; R ² = H; 1-S, 1'-R)	
<i>Cocculus pendulus</i>	Coccoline (200; R ¹ = R ² = H; 1-S, 1'-S)	322
	Coculine (200; R ¹ = Me; R ² = H; 1-S, 1'-S)	320
	Coculinine (201)	321
<i>Colubrina faralaotra</i> subsp. <i>faralaotra</i>	Faralaoitrine (194; R ¹ = H; R ² = Me; 1-S, 1'-S),	} 314
	Limacine (196; R ¹ = H; R ² = Me; 1-R, 1'-R)	
<i>Crematosperma</i> <i>polyphlebium</i>	Phlebicine (204; R ¹ = R ² = Me; R ³ = R ⁴ = H)	326
<i>Dephnandra</i> sp. ^a	1,2-Dehydromicranthine,	} 323
	ON-Dimethylmicranthine (200; R ¹ = R ² = Me; 1-R, 1'-R),	
	Micranthine (200; R ¹ = R ² = H; 1-R, 1'-R),	
	Pseudorepanduline (203; R ¹ = H; R ² = OMe),	
	(+)-Tenuipine (202)	
Krung Kha Mao	Berbamine (196; R ¹ = Me; R ² = H; 1-R, 1'-S)	315
	Fangchinoline (196; R ¹ = H; R ² = Me; 1-S, 1'-S)	315, 316
	Homoaromaline (194; R ¹ = H; R ² = Me; 1-S, 1'-R),	} 315
	Isochondodendrine	
	Isofangchinoline ^b (196; R ¹ = H; R ² = Me; 1-R, 1'-S)	316
	(-)-Limacine ^c (196; R ¹ = H; R ² = Me; 1-R, 1'-R),	} 315
	Phaeanthine (196; R ¹ = R ² = Me; 1-R, 1'-R),	
	Isotetrandrine (196; R ¹ = R ² = Me; 1-R, 1'-S),	
	Tetrandrine ^c (196; R ¹ = R ² = Me; 1-S, 1'-S)	} 317, 318
	Stepinone	
<i>Stephania japonica</i> <i>Tiliacora dinklagei</i> ^d	Funiferine (204; R ¹ = R ³ = R ⁴ = Me; R ² = H),	} 324
	Nortiliacorinine A,	
	Tiliacorinine	
	Tiliageine (204; R ¹ = R ² = H; R ³ = R ⁴ = Me)	

^a An alkaloid corresponding closely in properties to *O*-methylmicranthine (200; R¹ = H; R² = Me; 1-R, 1'-R) and an unidentified alkaloid were also isolated; ^b Identical with thalrugosine (*cf.* Vol. 4) and thaligine (*cf.* Vol. 5); ^c In excess over its enantiomer.

via oxidative degradation of a bisbenzylisoquinoline precursor. The new alkaloid was obtained, albeit in only 3% yield, by permanganate oxidation of oxyacanthine (194; R¹ = Me; R² = H; 1-S, 1'-R) which also occurs in this plant, together with obaberine (194; R¹ = R² = Me; 1-S, 1'-R). Similar oxidation of the latter gave the *O*-methyl ether (195; R = Me) in 35% yield.⁸⁵ Faralaoitrine (194; R¹ = H; R² = Me;

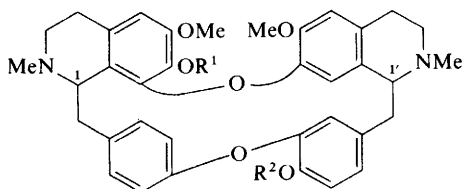

(194)

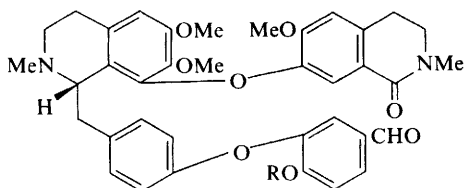

(195)

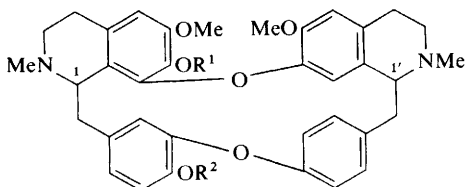

(196)

1-*S*, 1'-*S*), the antipode of the known alkaloid limacusine, is a new alkaloid which has been isolated from *Colubrina faralaotra* subsp. *faralaotra* together with the berbamine-type alkaloid (-)-limacine (196; $R^1 = H; R^2 = Me$; 1-*R*, 1'-*R*).³¹⁴ The diastereoisomer of faralaotrine, viz. homoaromaline (194; $R^1 = H; R^2 = Me$; 1-*S*, 1'-*R*), has been isolated from the Thai drug Krung Kha Mao, along with seven berbamine-type alkaloids and isochondodendrine.^{315,316} The alkaloid pattern strengthens the conviction that the drug is derived from *Cyclea barbata* (cf. Vol. 5). Full details of the isolation and structural elucidation of stepinone (cf. Vol. 4) have appeared.³¹⁷ The *ON*-dimethyltetrahydro-derivative (197) of the alkaloid has been converted into a mixture of *O*-methylrepanidine (194; $R^1 = R^2 = Me$; 1-*S*, 1'-*S*) and obaberine (194; $R^1 = R^2 = Me$; 1-*S*, 1'-*R*) via the imine (198) (Scheme 24).³¹⁸

The structure of thalibrunine (199) has been established by a combination of spectroscopic and degradative methods, including photo-oxidative degradation (cf. Vols. 3 and 4). The (1-*S*, 1'-*S*) configuration was assigned by comparison of its c.d. spectrum with that of hernandezine. Thalibrunine is the first bisbenzylisoquinoline alkaloid having a 2,3,4-trioxygenated benzyl group. It shows the properties characteristic of a highly hindered phenol.³¹⁹

³¹⁴ P. H. Guinaudeau, M. Leboeuf, M. Debray, A. Cavé, and R. R. Paris, *Planta Med.*, 1975, **27**, 304.

³¹⁵ T. Yuraphat, P. Pachaly, and F. Zymalkowski, *Planta Med.*, 1974, **25**, 315.

³¹⁶ C. R. Goepel, T. Yuraphat, P. Pachaly, and F. Zymalkowski, *Planta Med.*, 1974, **26**, 94.

³¹⁷ T. Ibuka, T. Konoshima, and Y. Inubushi, *Chem. and Pharm. Bull. (Japan)*, 1975, **23**, 114.

³¹⁸ T. Ibuka, T. Konoshima, and Y. Inubushi, *Chem. and Pharm. Bull. (Japan)*, 1975, **23**, 133.

³¹⁹ M. P. Cava, J. M. Saa, M. V. Lakshmikantham, M. J. Mitchell, J. L. Beal, R. W. Doskotch, A. Ray, D. C. De Jongh, and S. R. Shraker, *Tetrahedron Letters*, 1974, 4259.

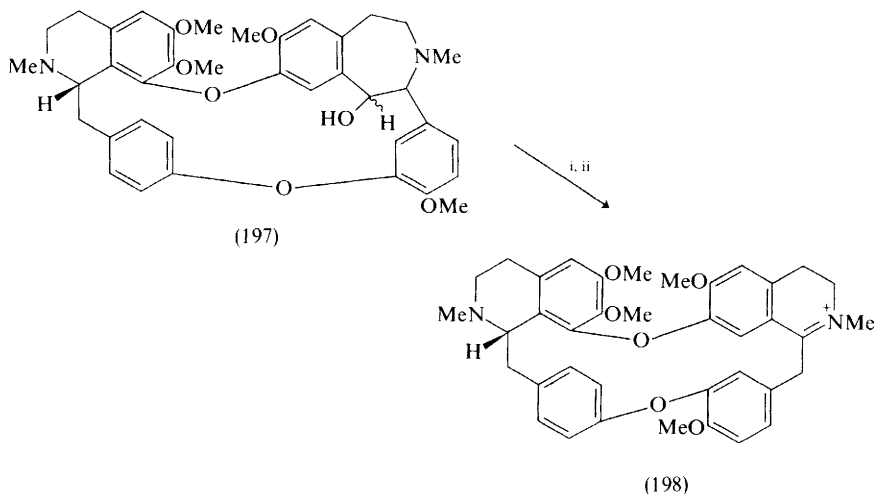

Reagents: i, Jones reagent; ii, Zn, HOAc

Scheme 24

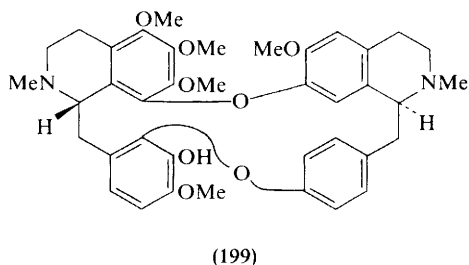

'Efrine' and 'trigilletine', isolated from *Triclisia gilletti* (*cf.* Vol. 5), are both identical with coculine (200; $R^1 = \text{Me}$; $R^2 = \text{H}$; 1-*S*, 1'-*S*), and the last name has priority.³²⁰ Two new alkaloids have been isolated from *Cocculus pendulus*.^{321,322} The first of these, cocsoline (200; $R^1 = R^2 = \text{H}$; 1-*S*, 1'-*S*) afforded coculine upon *N*-methylation. It also gave an *ON*-dimethyl derivative, which was identified as isotrilobine, and an *O*-methyl ether that was diastereoisomeric with telobine (*cf.* Vol. 4). The methylation pattern in the new alkaloid was assigned on the basis of n.m.r. and mass spectral evidence.³²² The second new alkaloid, cocsulinine (201), is a bis-coclaurine base of the menisarine type. It was found to be active against epidermoid carcinoma of the nasopharynx. Deuteriation studies and sodium-ammonia cleavage of the *OO*-diethyl ether played important parts in the structural elucidation.

³²⁰ N. Weber, M. M. Dhar, R. Huls, J. E. Knapp, D. J. Slatkin, P. L. Schiff, A. N. Tackie, D. Dwuma-Badu, and T. Okarter, *Phytochemistry*, 1974, **13**, 2326.

³²¹ P. P. Joshi, D. S. Bhakuni, and M. M. Dhar, *Indian J. Chem.*, 1974, **12**, 517.

³²² P. P. Joshi, D. S. Bhakuni, and M. M. Dhar, *Indian J. Chem.*, 1974, **12**, 649.

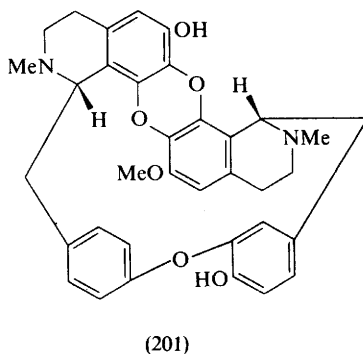
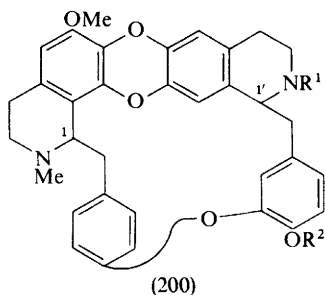

A new, unnamed, species of *Daphnandra* has afforded *ON*-dimethylmicranthine (200; $R^1 = R^2 = \text{Me}$; 1-*R*, 1'-*R*), as the major alkaloid, micranthine (200; $R^1 = R^2 = \text{H}$; 1-*R*, 1'-*R*), and tenuipine (202), which have not previously been found together in the same species of *Daphnandra*.³²³ Also obtained was the new alkaloid pseudorepanduline (203; $R^1 = \text{H}$; $R^2 = \text{OMe}$), which corresponded closely in properties to repanduline (203; $R^1 + R^2 = \text{OCH}_2\text{O}$), together with three minor alkaloids.

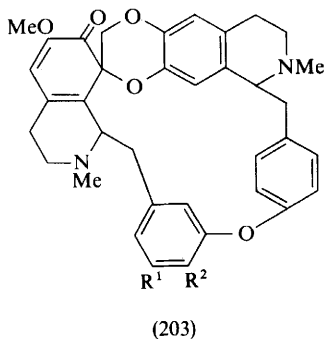
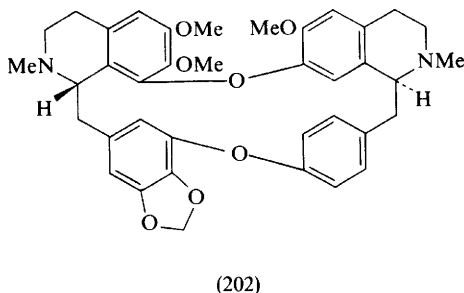

One of these was shown to be 1,2-dehydromicranthine, the second corresponded closely in properties to *O*-methylmicranthine, and the third was not identified.³²³

The new biphenyl alkaloid tiliageine (204; $R^1 = R^2 = \text{H}$; $R^3 = R^4 = \text{Me}$) has been isolated from *Tiliacora dinklagei* together with known alkaloids, including funiferine (204; $R^1 = R^3 = R^4 = \text{Me}$; $R^2 = \text{H}$).³²⁴ The dimethyl ether of tiliageine was shown to be identical with *O*-methylfuniferine (204; $R^1 = R^2 = R^3 = R^4 = \text{Me}$).³²⁵ Another new biphenyl alkaloid, phlebicine (204; $R^1 = R^2 = \text{Me}$; $R^3 = R^4 = \text{H}$), has been isolated from *Crematosperma polyphlebum*. Partial methylation afforded rodiasine (204; $R^1 = R^2 = R^3 = \text{Me}$; $R^4 = \text{H}$).³²⁶ Tiliageine, phlebicine, rodiasine, and funiferine thus belong to the same stereochemical series, although the absolute configuration is at present unknown.

³²³ I. R. C. Bick, H. M. Leow, and S. Sotheeswaran, *Tetrahedron Letters*, 1975, 2219.

³²⁴ A. N. Tackie, D. Dwuma-Badu, T. S. K. Ayum, T. T. Dabra, J. E. Knapp, D. J. Slatkin, and P. L. Schiff jun., *Lloydia*, 1975, **38**, 210.

³²⁵ A. N. Tackie, D. Dwuma-Badu, T. T. Dabra, J. E. Knapp, D. J. Slatkin, and P. L. Schiff, *Experientia*, 1974, **30**, 847.

³²⁶ M. P. Cava, K. Wakisaka, I. Noguchi, D. L. Edire, and A. I. da Rocha, *J. Org. Chem.*, 1974, **39**, 3588.

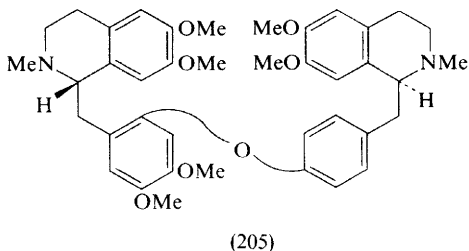
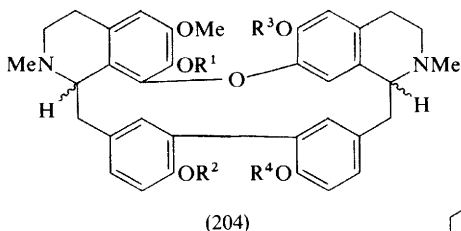

The bisbenzylisoquinoline (205) has been synthesized from 6-bromolaudanosine and arnepavine by an improved Ullmann procedure, using pentafluorophenylcopper in dry pyridine.³²⁷

Treatment of (+)-tubocurarine (206; $R^1 = H$; $R^2 = Me$), (+)-isotubocurarine (206; $R^1 = Me$; $R^2 = H$) and chondocurarine (206; $R^1 = R^2 = Me$) at room temperature with an excess of diazomethane resulted in Hofmann elimination at quaternary centres to give (207), (208), and (209), respectively. The mode of elimination was discussed in relation to the conformation of the alkaloids (*cf.* Vol. 4).³²⁸

The preparation and curarimetric activity relative to (+)-tubocurarine chloride of (+)-isotubocurarine,³²⁹ *NN*-dimethyl-(+)-chondocurarine, and *NN*'-dimethyl-(−)-curine³³⁰ have been described. T.l.c. procedures for detection of bisbenzylisoquinolines such as (+)-tubocurarine and its isomers have been reviewed.³³¹ The use

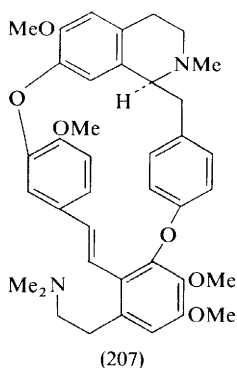
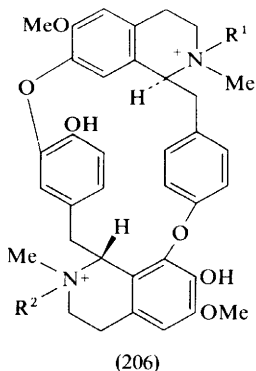

³²⁷ M. P. Cava and A. Afzali, *J. Org. Chem.*, 1975, **40**, 1553.

³²⁸ J. Naghaway, N. A. Shaath, and T. O. Soine, *J. Org. Chem.*, 1975, **40**, 539.

³²⁹ T. O. Soine and J. Naghaway, *J. Pharm. Sci.*, 1974, **63**, 1643.

³³⁰ I. R. C. Bick and L. J. McLeod, *J. Pharm. Pharmacol.*, 1974, **26**, 985.

³³¹ J. Tyfczynska, in ref. 250, p. 188 (*Chem. Abs.*, 1975, **82**, 103 200).

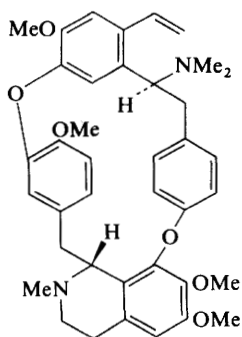

(208)

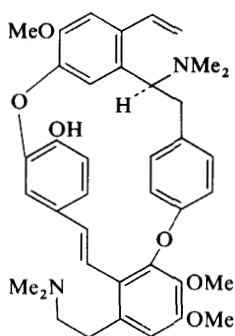

(209)

of phaeanthine and closely related alkaloids as anti-cancer agents has been reviewed.³³² Reports are also available dealing with the antibacterial activity of oxyacanthine chloride in extracts of *Berberis vulgaris*,²⁵³ the toxicology of (+)-tetrandrine,³³³ and the antiarrhythmic action of thalisopine.³³⁴

³³² A. C. Santos, *Acta Manilana, Ser. A.*, 1974, **12**, 48 (*Chem. Abs.*, 1975, **82**, 95 236).

³³³ E. J. Grilla, G. L. Coleman, and A. M. Jonas, *Cancer Chemotherapy Reports, Part 3*, 1974, **5**, 79.

³³⁴ Z. S. Akbarov, Kh. U. Aliev, and M. B. Sultanov, *Farmakol. Alkaloidov Ikh. Proizvod.*, 1972, 129 (*Chem. Abs.*, 1974, **81**, 20 880).

1 Introduction

The term 'aporphinoids' covers aporphines and their close biogenetic precursors, the proaporphines. Alkaloids derived from relatively straightforward biological transformations of proaporphines or of aporphines are also encompassed, so that proaporphine-benzylisoquinolines, aporphine-benzylisoquinolines, aporphine-pavines, oxoaporphines, dioxoaporphines, aristolactams, and aristolochic acids, as well as phenanthrenes, will be discussed. Azafluoranthenes are also included within the scope of aporphinoids for reasons which will become clear toward the end of the present chapter.

A detailed listing of aporphinoids and other isoquinoline alkaloids has appeared.¹ The early steps in the biogenesis of aporphines have been clarified by the finding that dopa may be converted in *Papaver orientale* into 3,4-dihydroxyphenylpyruvic acid.² So many new aporphines have been isolated and characterized that this group has now overtaken the bisbenzylisoquinolines to become the most abundant within the isoquinoline alkaloids. Pennsylvavine and pennsylvavoline are the first known aporphine-pavine dimers.³ Cepharadione-A and cepharadione-B⁴ are the first representatives of the dioxoaporphines, and their natural occurrence together with the corresponding aristolactams, namely cepharanone-A and aristolactam-BII, is of importance in biogenetic considerations.

2 Proaporphines

New proaporphines are crociflorinone (1), obtained from *Colchicum kesselringii* (*C. crociflorum*),⁵ and roehybrine (2), found in *Roemeria hybrida* (L.) DC.⁶

The known proaporphine stepharine has now been found in *Stephania dinklagei* Diels.⁷ Mecambrine (3) has been synthesized in 10% yield by irradiation of the appropriate 8-bromo-4'-hydroxytetrahydrobenzylisoquinoline,⁸ while glaziovine

¹ T. Kametani, 'The Chemistry of the Isoquinoline Alkaloids', Volume 2, Kikodo Publishing Co., Sendai, 1974.

² M. L. Wilson and C. J. Coscia, *J. Amer. Chem. Soc.*, 1975, **97**, 431.

³ M. Shamma and J. L. Moniot, *J. Amer. Chem. Soc.*, 1974, **96**, 3338.

⁴ M. Akasu, H. Itokawa, and M. Fujita, *Tetrahedron Letters*, 1974, 3609.

⁵ K. Turdikulov, M. K. Yusupov, K. A. Aslanov, and A. S. Sadykov, *Khim. prirod. Soedinenii*, 1974, 810.

⁶ J. Slavík, L. Dolejš, and L. Slavíková, *Coll. Czech. Chem. Comm.*, 1974, **39**, 888.

⁷ A. N. Tacki, D. Dwuma-Badu, P. A. Lartey, P. L. Schiff, jun., J. E. Knapp, and D. J. Slatkin, *Lloydia*, 1974, **37**, 6.

⁸ Z. Horii, S. Uchida, Y. Nakashita, E. Tsuchida, and C. Iwata, *Chem. and Pharm. Bull. (Japan)*, 1974, **22**, 583.

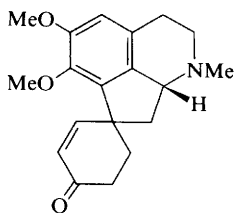

(1)

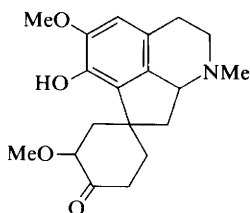

(2)

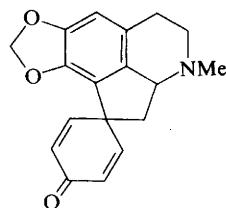

(3)

(4) was prepared in low yield from the corresponding 4'-aminotetrahydrobenzylisoquinoline by treatment with NaOCl and then KOBu^t.⁹ An alternate route to glaziovine involves reaction of the appropriate 7,4'-dihydroxy-8-bromotetrahydrobenzylisoquinoline with tri-n-butylstannane in the presence of lauroyl peroxide in benzene.¹⁰

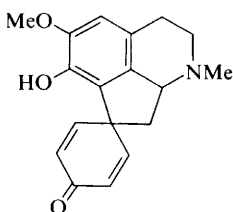

(4)

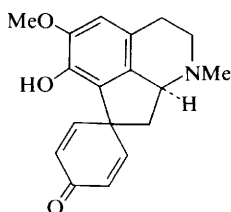

(5)

A detailed study of the mass spectral behaviour of proaporphines has been carried out. The fragmentation process strongly depends upon the oxidation pattern of ring D as well as on the nature of the substituents in ring A.¹¹

N-Methylcrotsparine (5) is a hypotensive agent,¹² and proaporphines incorporating a dienone system may possess both analgesic and hypotensive activity (no data).¹³ There is a claim that glaziovine (4) may be used as a tranquillizer;¹⁴ the alkaloid does possess anxiolytic properties similar to diazepam.¹⁵

3 Aporphines

Recently isolated aporphines, together with their botanical sources, include (6)—(27).¹⁶

⁹ T. Kametani, K. Takahashi, K. Ogasawa, and K. Fukumoto, *Tetrahedron Letters*, 1973, 4219; T. Kametani, K. Takahashi, K. Ogasawa, C. V. Loc, and K. Fukumoto, *Coll. Czech. Chem. Comm.*, 1975, **40**, 712.

¹⁰ J. Warnant, A. Farcilli, I. Medici, and E. Toromanoff, Ger. Offen. 2 409 007 (*Chem. Abs.*, 1974, **82**, 4449).

¹¹ L. Dolejš, *Coll. Czech. Chem. Comm.*, 1974, **39**, 571.

¹² M. P. Dubey, R. C. Srimal, and B. N. Dhawan, *Indian J. Pharmacol.*, 1969, **7**, 73.

¹³ S. Ishiwatari, K. Itakura, and K. Misawa, Jap. Patent 73 26 015, December, 1970 (*Chem. Abs.*, 1974, **80**, 3688).

¹⁴ C. Casagrande and L. Canonica, Ger. Offen. 2 363 529 (*Chem. Abs.*, 1974, **81**, 105 780, 105 783).

¹⁵ B. Buffa, G. Costa, and P. Ghirardi, *Current Therap. Res., Clin. Exp.*, 1974, **16**, 621.

¹⁶ This list supplements and brings up-to-date that given by M. Shamma and S. S. Salgar; in 'The Alkaloids', ed. J. E. Saxton (Specialist Periodical Reports), The Chemical Society, London, Vol. 4, pp. 254—264.

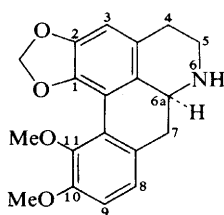

(+)-Litsedine (6)
Litsea nitida Roxb.¹⁷

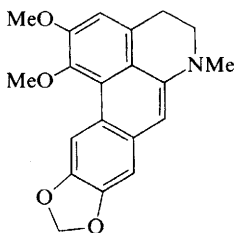

Dehydronantenine (7)
Nandina domestica Thunb.¹⁸

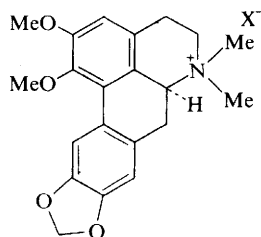

(+)-Nantenine methochloride (8)
Thalictrum polygamum Muhl.¹⁹

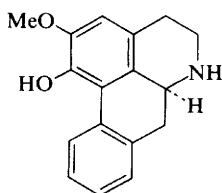

(+)-Caaverine (9)
*Liriodendron tulipifera*²⁰

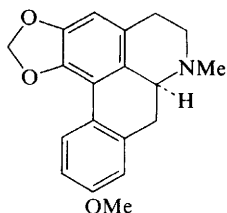

(+)-Isolaureline (10)
*Liriodendron tulipifera*²¹

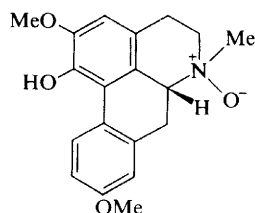

Lirinine N-oxide (11)
*Liriodendron tulipifera*²²

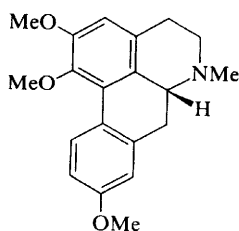

(-)-O-Methyl-lirinine (12)
*Liriodendron tulipifera*²²

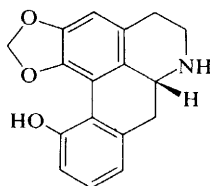

(-)-Obovanine (13)
Magnolia obovata Thunb.²³

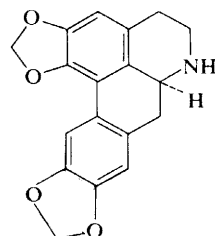

(+)-Cryptodorine (14)
Cryptocarya odorata
(Panch. et Seb.) Guillaum.²⁴

¹⁷ P. C. Patnaik and K. W. Gopinath, *Indian J. Chem.*, 1975, **13**, 197.

¹⁸ J.-I. Kunitomo, M. Ju-ichi, Y. Ando, Y. Yoshikawa, S. Nakamura, and T. Shingu, *J. Pharm. Soc. Japan*, 1975, **95**, 445.

¹⁹ M. Shamma and J. L. Moniot, *Heterocycles*, 1975, **3**, 297.

²⁰ R. Ziyaev, A. Abdusamatov, and S. Yu. Yunusov, *Khim. prirod. Soedinenii*, 1973, 760.

²¹ R. Ziyaev, A. Abdusamatov, and S. Yu. Yunusov, *Khim. prirod. Soedinenii*, 1974, 685 (*Chem. Abs.*, 1974, **82**, 86 460).

²² R. Ziyaev, A. Abdusamatov, and S. Yu. Yunusov, *Khim. prirod. Soedinenii*, 1973, 505; *Chem. Natural Compounds*, 1975, 475 (*Chem. Abs.*, 1974, **80**, 60 055).

²³ K. Ito and S. Asai, *J. Pharm. Soc. Japan*, 1974, **94**, 729.

²⁴ I. R. C. Bick, N. W. Preston, and P. Potier, *Bull. Soc. chim. France*, 1972, 4596.

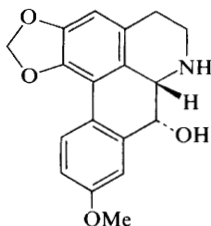

(-)-Michelanugine (15)
Michelia lanuginosa Wall²⁵

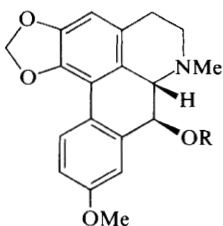

(-)-Oliveridine (R = H) (16)
(+)-Oliverine (R = Me) (17)
Polyalthia oliveri Engl.²⁵

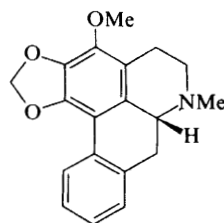

(-)-Stephalagine (18)
Stephania dinklagei Diels²⁶

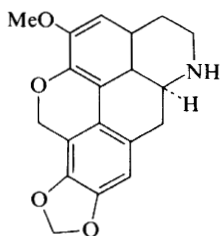

(+)-Bisnortalphenine (19)
Thalictrum polygamum Muhl.²⁷

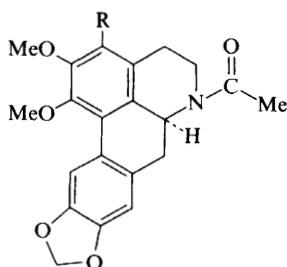

(+)-*N*-Acetylnornantene (R = H) (20)
(+)-*N*-Acetyl-3-methoxy-
nornantene (R = OMe) (21)
Liriodendron tulipifera L.²⁸

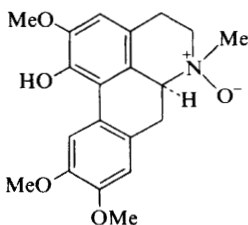

Thalictmidine *N*-oxide
(22)
*Thalictrum minus*²⁹

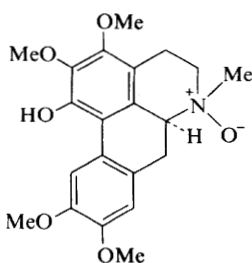

Preocoteine *N*-oxide (23)
*Thalictrum minus*²⁹

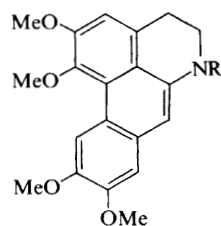

Dehydronorglaucine (24) R = H
*Glaucium flavum*³⁰

²⁵ S. K. Talapatra, A. Patra, and B. Talapatra, *Tetrahedron*, 1975, **31**, 1105.

²⁶ M. Hamonnière, M. Leboeuf, and A. Cavé, *Compt. rend.*, 1974, **278**, C, 921.

²⁷ M. Shamma and J. L. Moniot, *Heterocycles*, 1974, **2**, 427.

²⁸ C. D. Hufford and M. J. Funderburk, *J. Pharm. Sci.*, 1974, **63**, 1338; C. D. Hufford, M. J. Funderburk, J. M. Morgan, and L. W. Robertson, *J. Pharm. Sci.*, 1975, **64**, 789.

²⁹ V. G. Khozhdaev, S. Kh. Maekh, and S. Yu. Yunusov, *Khim. prirod. Soedinenii*, 1972, 631; *Chem. Natural Compounds*, 1974, 599.

³⁰ K. H. B. Duchevska, A. Orahovats, and N. M. Mollov, *Doklady Bolg. Akad. Nauk*, 1973, **26**, 899.

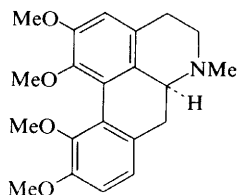

(+)-O,O-Dimethylcorytuberine (25)
*Hermandia jamaicensis*³¹

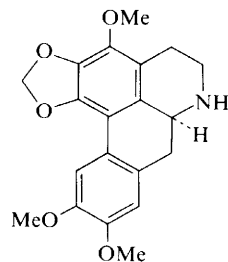

(+)-O-Methylcassyfiline (26)
*Cassythia americana*³²

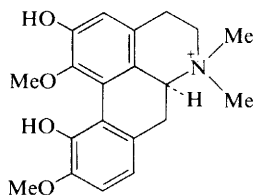

(+)-NN-Dimethyl-lindcarpine (27)
Menispermum canadense L.³³

Of these, (+)-oliverine (17) is the first C-7-methoxylated aporphine, while (20) and (21) are the only known naturally occurring amidic noraporphines.

Several dehydroaporphines have been tentatively detected by t.l.c.–g.c., but have not been fully characterized. These include dehydronuciferine,³⁴ dehydroanonaïne,³⁴ dehydrooemerine,³⁴ and dehydroisoboldine.³⁵ Dihydroaporphine (dihydrooemerine) has also been reported.³⁶

Known aporphines re-isolated from plant sources are:

(+)-Corydine	<i>Glaucium elegans</i> ³⁷
(+)-Isocorydine	<i>Doryphora sassafras</i> Endlicher ³⁸
	<i>Glaucium elegans</i> ³⁷
(–)-Anonaïne	<i>Doryphora sassafras</i> Endlicher ³⁸
(+)-Isoboldine	<i>Glaucium elegans</i> ³⁷
	<i>Glaucium grandiflorum</i> ³⁹
(+)-Thaliporphine	<i>Glaucium flavum</i> ³⁰
Dehydro-ocoteine	<i>Thalictrum isopyroides</i> ⁴⁰

³¹ M. P. Cava and A. Venkateswarlu, *Tetrahedron*, 1971, **27**, 2639.

³² M. P. Cava, K. V. Rao, B. Douglas, and J. A. Weisbach, *J. Org. Chem.*, 1968, **33**, 2443.

³³ R. W. Doskotch and J. E. Knapp, *Lloydia*, 1971, **34**, 292.

³⁴ J.-I. Kunitomo, Y. Yoshikawa, S. Tanaka, Y. Imori, K. Isoi, Y. Masada, K. Hashimoto, and T. Inoue, *Phytochemistry*, 1973, **12**, 699.

³⁵ J. I. Kunitomo, M. Ju-ichi, Y. Yoshikawa, Y. Masada, K. Hashimoto, T. Inoue, and M. Fujioka, *J. Pharm. Soc. Japan*, 1974, **94**, 1149.

³⁶ V. Preininger and V. Tosnarova, *Planta Medica*, 1973, **23**, 233.

³⁷ L. D. Yakhontova, O. N. Tolkachev, and Yu. V. Baranova, *Khim. prirod. Soedinenii*, 1973, 686.

³⁸ C. R. Chen, J. L. Beal, R. W. Doskotch, L. A. Mitscher, and G. H. Svoboda, *Lloydia*, 1974, **37**, 493.

³⁹ L. D. Yakhontova, O. N. Tolkachev and D. A. Pakaln, *Khim. prirod. Soedinenii*, 1973, 684.

⁴⁰ I. A. Benages, M. E. A. de Juarez, S. M. Albonico, A. Urzua, and B. K. Cassels, *Phytochemistry*, 1974, **13**, 2891.

Dehydroglauicine	<i>Liriodendron tulipifera</i> ²⁸
(+)- <i>O</i> -Demethylnuciferine (lirinidine)	<i>Liriodendron tulipifera</i> ²⁰
(+)-Glauicine	<i>Magnolia obovata</i> Thunb. ²³ <i>Glaucium elegans</i> ³⁷ <i>Glaucium grandiflorum</i> ³⁹
(-)-Asimilobine	<i>Magnolia obovata</i> Thunb. ²³
(+)-Actinodaphnine	<i>Litsea nitida</i> ¹⁷
(+)-Dicentrine	<i>Litsea nitida</i> ¹⁷
(+)-Magnoflorine	<i>Fagara mayu</i> Engler ⁴⁰ Papaveraceae callus tissues ⁴¹ <i>Glaucium flavum</i> ⁴²
(-)-Nuciferine	<i>Ziziphus amphibia</i> A. Cheval. ⁴³
(+)-Boldine	<i>Litsea turfosa</i> ⁴⁴
(+)-Lauroilsine	<i>Litsea turfosa</i> ⁴⁴

The applications of Reissert compounds,⁴⁵ as well as enamide photocyclization,⁴⁶ and other methods,⁴⁷ to the syntheses of aporphines have been reviewed.

A detailed account of the preparation of 7-hydroxyaporphines using oxazolinones as protective groups has been given.⁴⁸ The synthesis of thalphenine iodide (29) through photolysis of the phenolic tetrahydrobenzylisoquinoline (28) in basic solution, followed by quaternization, has been described in full.⁴⁹

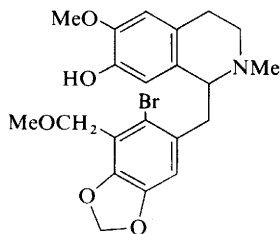

(28)

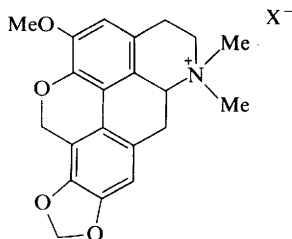

(29)

The use of lead tetra-acetate in aporphine synthesis⁵⁰ has been extended by the conversion of (\pm)-thaliporphine (30) into the 4-acetoxythaliporphine (31), which could be converted into cataline (32) in high yield (see Scheme).⁵¹

⁴¹ A. Ikuta, K. Syono, and T. Furuya, *Phytochemistry*, 1974, **13**, 2975.

⁴² V. Novák and J. Slavík, *Coll. Czech. Chem. Comm.*, 1974, **39**, 3352.

⁴³ R. Tschesche, C. Spilles, and G. Eckhardt, *Chem. Ber.*, 1974, **107**, 1329.

⁴⁴ D. M. Holloway and F. Scheinmann, *Phytochemistry*, 1973, **12**, 1503.

⁴⁵ F. D. Popp, *Heterocycles*, 1973, **1**, 165.

⁴⁶ I. Ninomiya, *Heterocycles*, 1974, **2**, 105.

⁴⁷ T. Kametani and F. Fukumoto, *Heterocycles*, 1974, **2**, 129.

⁴⁸ F. E. Granchelli and J. L. Neumeyer, *Tetrahedron*, 1974, **30**, 3701.

⁴⁹ M. Shamma and D.-Y. Hwang, *Tetrahedron*, 1974, **30**, 2279.

⁵⁰ O. Hoshino, T. Toshioka, and B. Umezawa, *Chem. and Pharm. Bull. (Japan)*, 1974, **22**, 1302.

⁵¹ O. Hoshino, H. Hara, M. Ogawa, and B. Umezawa, *J.C.S. Chem. Comm.*, 1975, 306.

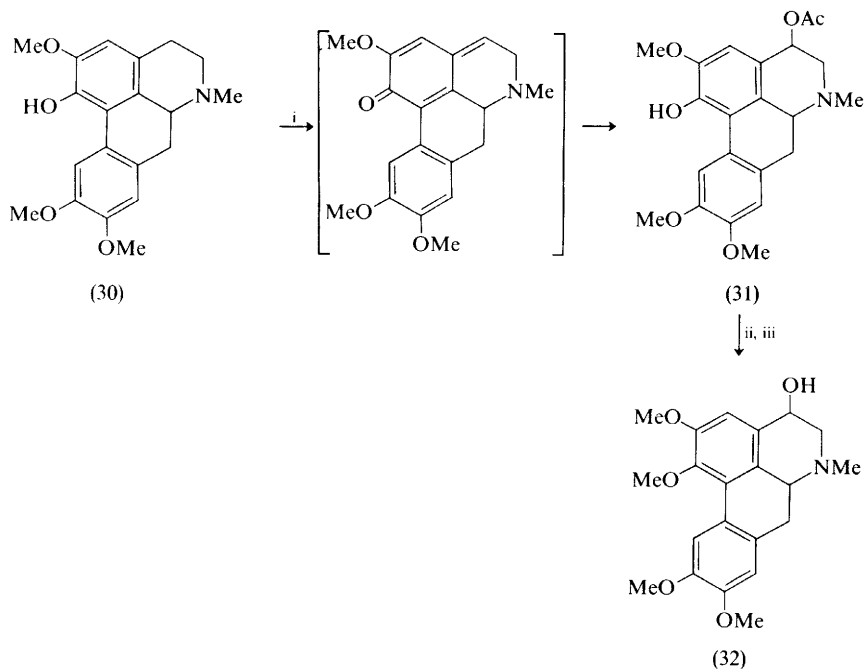

Reagents: i, $\text{Pb}(\text{OAc})_4$; ii, H_3O^+ ; iii, CH_2N_2

Scheme

(±)-Norpredicentrine (34) has been prepared by photolysis of (33).⁵²

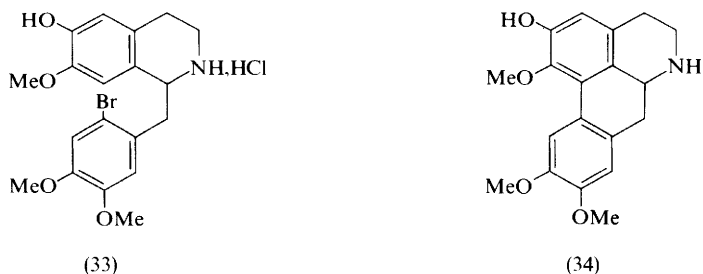

In the first fully authenticated dimerization of an aporphine base, reaction of (+)-*O*-methylbulbocapnine (35) with iodine in ethanol–water produced the salt (36), whose reduction with zinc in sulphuric acid gave (±)-(35). Alternatively, reduction of (36) with lithium aluminium hydride in ether supplied a pair of diastereoisomeric dimers (37).⁵³

⁵² M. S. Premila and B. R. Pai, *Indian J. Chem.*, 1975, **13**, 13.

⁵³ M. Gerecke, R. Borer, and A. Brossi, *Chimia. (Switz.)*, 1975, **29**, 27; *Helv. Chim. Acta*, 1975, **58**, 185.

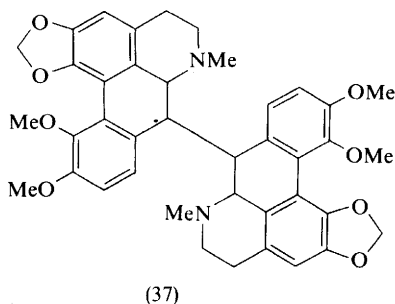
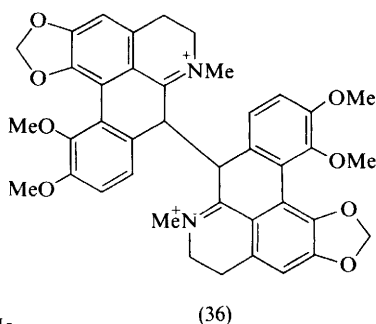
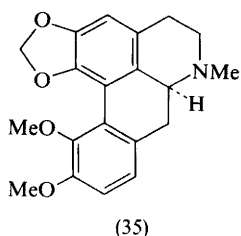

Hofmann elimination of nuciferine methiodide using sodium ethoxide led to the phenanthrene derivative (38), but use of the bulkier base potassium triethylcarbinolate afforded the optically active styrene (39).³⁹ The dihydrophenanthrene (40) was obtained through Emde reduction of the starting methiodide salt using sodium amalgam in water.⁵⁴

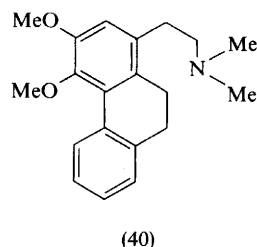
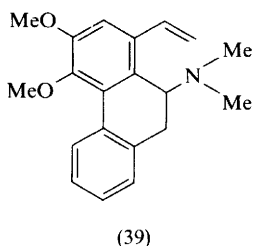
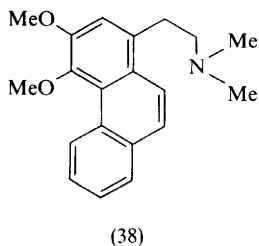

The separation and tentative characterization of aporphine and related alkaloids present in *Nandina domestica* Thunb. has been achieved using t.l.c.-g.c.³⁵ The intensities of i.r. bands of aporphines in the 1480—1630 cm^{-1} region have been used to determine the substitution pattern at C-1 and C-11 for a variety of aporphines and dehydroaporphines.⁵⁵

Pharmacological studies on aporphines have centred mainly around (-)-apomorphine (41) and its close relatives because this degradation product of morphine stimulates the dopaminergic system in rats and mice, and has anti-Parkinson activity. It also has a hypotensive effect; and very recently has been shown

⁵⁴ J. G. Cannon, P. R. Khonje, and J. P. Long, *J. Medicin. Chem.*, 1975, **18**, 110; see also J. G. Cannon, R. J. Borgman, M. A. Aleem, and J. P. Long, *J. Medicin. Chem.*, 1973, **16**, 219.

⁵⁵ E. I. Kristalovich, M. R. Yagudaev, Z. F. Ismailov, and S. Yu. Yunusov, *Khim. prirod. Soedinenii*, 1973, 646; *Chem. Natural Compounds*, 1975, 610.

to decrease serum prolactin levels in patients with hyperprolactinemia, including cases with pituitary tumours.^{56a,b,c} Various efforts, described below, have therefore been directed at defining the structural parameters which control physiological activity in the apomorphine series.

Urine analysis has shown that apocodeine (42), which shows only about one-fourth the central nervous system activity of apomorphine in rats, is converted *in vivo* into apomorphine and norapomorphine, thus explaining its limited activity.⁵⁷

Of several aporphines structurally related to apomorphine, 11-hydroxyaporphine has proven to be active upon oral administration to spontaneously hypertensive cats.^{56a} That a catechol system is not an absolute requirement for dopaminergic activity was demonstrated by the finding that (\pm)-(43) and (\pm)-(44) show appreciable activity in rats.

(-)-10-Methoxyaporphine has been prepared for physiological testing by sodium in liquid ammonia hydrogenolysis of (-)-*OO*-dimethylapomorphine,⁵⁹ and *OO*-diacetylapomorphine can be prepared in high yield using acetyl bromide in trifluoroacetic acid.⁶⁰ It has been suggested that 5-hydroxytryptamine has an essential role in the mediation of the hyperthermic response of rabbits to apomorphine.⁶¹

N-Methylsparsiflorine methiodide (45), like the related proaporphine *N*-methylcrotsparine (5), produces hypotension.¹² Dehydroglaucine has antimicrobial activity.²⁸ Pairs of enantiomeric methiodides of glaucine, corydine, isocorydine, and boldine were individually examined for curarimimetic activity in cats, but because of

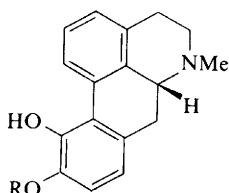

(41) R = H
(42) R = Me

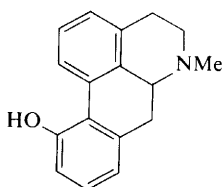

(43)

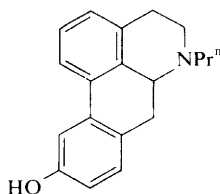

(44)

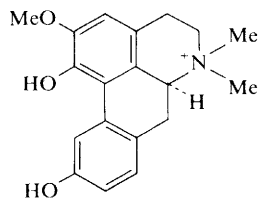

(45)

⁵⁶ For leading references on the action of apomorphine see: (a) W. S. Saari, S. W. King, V. J. Lotti, and A. Scriabine, *J. Medicin. Chem.*, 1974, **17**, 1086; (b) S. Lal, Abstracts Los Angeles A.C.S. Meeting, Spring 1974, Symposium on Central Dopamine Receptors, No. 8; and (c) J. L. Neumeyer, F. E. Granchelli, K. Fuxe, U. Ugerstedt, and H. Corrodi, *J. Medicin. Chem.*, 1974, **17**, 1090.

⁵⁷ R. V. Smith and M. R. Cook, *J. Pharm. Sci.*, 1974, **63**, 161.

⁵⁸ J. L. Neumeyer, W. P. Dafeldecker, R. I. Schoenfeld, and S. Roffler-Tarlov, 168th A.C.S. Med. Chem. Meeting, Atlantic City, New Jersey, September, 1974.

⁵⁹ R. J. Borgman, *J. Heterocyclic Chem.*, 1975, **12**, 599.

⁶⁰ R. J. Borgman, R. V. Smith, and J. E. Keiser, *Synthesis*, 1975, 249.

⁶¹ R. M. Quock and A. Horita, *Science*, 1974, **183**, 539.

low and random activity no firm correlation could be drawn between activity and stereochemistry.⁶²

4 Proaporphine- and Aporphine-Benzyloquinoline Dimers

Two new aporphine-benzyloquinoline dimers from *Thalictrum polygamum* Muhl. are pennsylvanine (46) and pennsylvanamine (47).^{63,64}

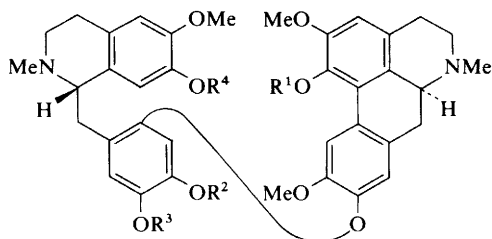

Pennsylvanine (46) $R^3 = H$; $R^1 = R^2 = R^4 = Me$

Pennsylvanamine (47) $R^1 = R^3 = H$; $R^2 = R^4 = Me$

Thalidoxine (48) $R^2 = H$; $R^1 = R^3 = R^4 = Me$

Thalicarpine (49) $R^1 = R^2 = R^3 = R^4 = Me$

Thalictropine (50) $R^1 = H$; $R^2 = R^3 = R^4 = Me$

Thalictrogamine (51) $R^1 = R^4 = H$; $R^2 = R^3 = Me$

Thalmelatine (52) $R^4 = I$; $R^1 = R^2 = R^3 = Me$

A sufficiently large number of aporphine-benzyloquinoline dimers have now been isolated for generalizations to be drawn concerning their biogenesis. Aporphine-benzyloquinolines related to the octaoxygenated thalicarpine (49), such as pennsylvanine (46), pennsylvanamine (47), thalictropine (50), thalictrogamine (51), and thalmelatine (52), must be formed *via* oxidative coupling of a 1,2,9,10-tetraoxygenated aporphine hydroxylated at C-9 with a molecule of (+)-reticuline. The tetraoxygenated aporphine is itself probably formed by intramolecular oxidative coupling of (+)-reticuline.⁶⁵ On the other hand, pakistanine (57),⁶⁶ which is a hexaoxygenated aporphine-benzyloquinoline alkaloid, originates from intermolecular phenolic coupling of two trioxygenated and enantiomeric *N*-methylcoclaurine units to provide the bisbenzyloquinoline (53), corresponding to the alkaloid berbaminine. Intramolecular phenolic coupling would then provide the proaporphine-benzyloquinoline dimer (54) related to pakistanamine (55). Subsequent dienone-phenol rearrangement can supply (56), a close relative of pakistanine (57).⁶⁶

It is worth pointing out that if thalicarpine (49) or one of its octaoxygenated analogues were to be formed through a bisbenzyloquinoline, such an intermediate would have to originate by coupling of two reticuline units. Even though more than one hundred bisbenzyloquinolines are presently known, none are derived from condensation of a pair of reticulines. It follows that thalicarpine (49) and pakistanine

⁶² P. W. Erhardt and T. O. Soine, *J. Pharm. Sci.*, 1975, **64**, 53.

⁶³ M. Shamma and J. L. Moniot, *Tetrahedron Letters*, 1974, 2291.

⁶⁴ M. Shamma, A. S. Rothenberg, and J. L. Moniot, unpublished results.

⁶⁵ M. Shamma and J. L. Moniot, unpublished observations.

⁶⁶ M. Shamma, J. L. Moniot, S. Y. Yao, G. A. Miana, and M. Ikram, *J. Amer. Chem. Soc.*, 1973, **95**, 5742.

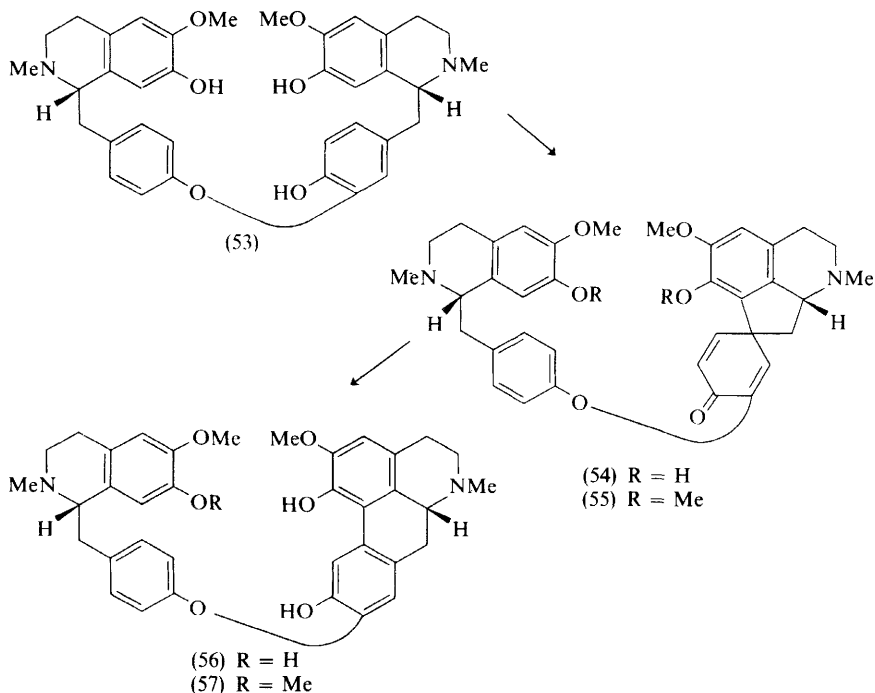

(57) dimers are formed through radically different pathways, with *only* the pakistanamine series going through a dimeric proaporphine–benzylisoquinoline intermediate.⁶⁵

Two syntheses of racemic and/or enantiomeric mixtures of pakistanamine are now available. In the first synthesis, ferricyanide oxidation of racemic berbaminine [\pm -(53)] resulted in formation of an isomeric mixture (54), which upon treatment with diazomethane provided an oil. Chromatography of this oil yielded racemic material corresponding to pakistanamine (55).⁶⁷ More recently, irradiation of the dimeric bromophenol (58) in refluxing liquid ammonia containing potassium *t*-butoxide gave rise to pakistanamine in 25–30% yield.⁶⁸

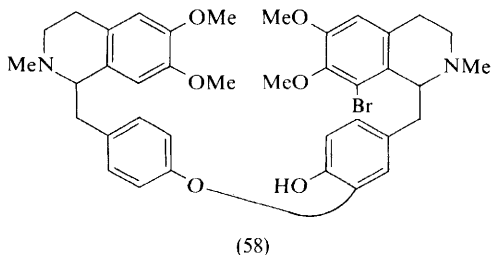

⁶⁷ T. Kametani, H. Terasawa, and F. Satoh, *Heterocycles*, 1974, **2**, 159.

⁶⁸ S. Kokrady and R. E. Harmon, 168th A.C.S. National Meeting, Atlantic City, New Jersey, September 1974, No. 85.

5 Aporphine–Pavine Dimers

A continuing investigation of the alkaloids of *Thalictrum polygamum* Muhl. has resulted in the isolation of members of an interesting and novel isoquinoline group, the aporphine–pavine dimers. Pennsylvavine (59) and pennsylvavoline (60) are weakly basic phenolic alkaloids which are accompanied in the plant by the aporphine–benzylisoquinolines pennsylvanine (46) and pennsylvanine (47). It therefore seems likely that (46) and (47) are biogenetic precursors for (59) and (60), respectively.³

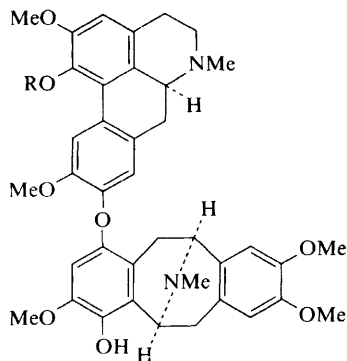

(59) R = Me

(60) R = H

6 Oxoaporphines

Oxoaporphines, together with their plant sources, which should be added to the listing provided in the last review on the subject⁶⁹ include (61)—(63).

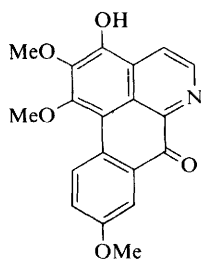

Subsessiline (61)
*Guatteria subsessilis*⁷⁰

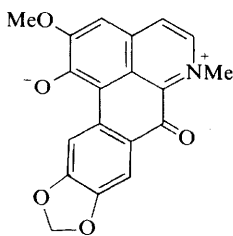

Nandazurine (62)
Nandina domestica Thunb.⁷¹

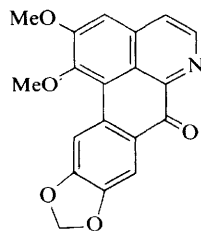

Oxonantenine (63)
Cassipoupa racemosa Nees.⁷²

⁶⁹ M. Shamma and R. L. Castenson, 'The Alkaloids', Vol. 14, ed. R. H. F. Manske, Academic Press, New York, 1973, p. 226.

⁷⁰ M. Hasegawa, M. Sojo, A. Lira, and C. Marquez, *Acta Cient. Venezuelana*, 1972, **23**, 165 (*Chem. Abs.*, 1973, **79**, 42 716).

⁷¹ J. Kunitomo, M. Ju-ichi, Y. Yoshikawa, and H. Chikamatsu, *Experientia*, 1973, **29**, 518; *J. Pharm. Soc. Japan*, 1974, **94**, 97.

⁷² S. R. Johns, J. A. Lamberton, and A. A. Sioumis, *Austral. J. Chem.*, 1967, **20**, 1457.

The structure 8,9-dimethoxyliriodenine (1,2-methylenedioxy-8,9-dimethoxyoxoaporphine) has been tentatively assigned to a new alkaloid found in *Uvariopsis guineensis* Keay.⁷³

Known oxoaporphines that have been re-isolated recently are:

Lanuginosine	<i>Uvariopsis guineensis</i> Keay ⁷³ <i>Magnolia campbelli</i> ^{74,25}
Liriodenine	<i>Uvariopsis guineensis</i> Keay ⁷³ <i>Magnolia campbelli</i> and <i>M. mutabilis</i> ⁷⁴ <i>Doryphora sassafras</i> Endlicher ³⁸ <i>Liriodendron tulipifera</i> L. ²⁸ <i>Magnolia obovata</i> Thunb. ²³ <i>Triclisia gillettii</i> ⁷⁵ <i>Gutteria subsessilis</i> ⁷⁰
O-Methylmoschatoline	
Oxoglaucine (1,2,9,10-tetramethoxyoxoaporphine)	<i>Glaucium grandiflorum</i> and <i>G. serpierei</i> ³⁹
Thalicmine	<i>Ocotea puberula</i> ⁷⁶

The identity of the alkaloid glauvine [presumably (64)] found in *Glaucium flavum*⁷⁷ as well as in *G. grandiflorum* and *G. serpierei*³⁹ has been seriously questioned.⁷⁸ Corunnine (65) and glauvine are green, possess very similar u.v. and n.m.r. spectra, and are both present in *Glaucium* spp. The structure of corunnine has been unambiguously confirmed by two different syntheses;^{79,80} but no sample of glauvine was available for comparison with corunnine. It seems likely, however, that glauvine is identical with corunnine (65).⁷⁸

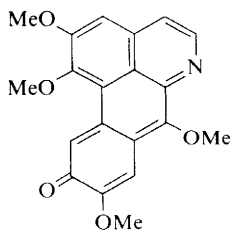

(64)

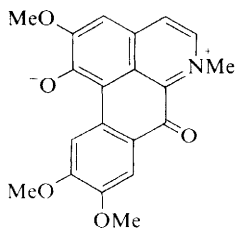

(65)

An efficient route to non-phenolic oxoaporphines involves lead tetra-acetate oxidation of the corresponding aporphine. Glaucine was thus oxidized to a mixture of dehydroglaucine [(24)R = NMe] and oxoglaucine (1,2,9,10-tetramethoxyoxoaporphine). Further lead tetra-acetate treatment of dehydroglaucine also provided oxoglaucine. Finally, heating oxoglaucine at 150°C for 32 h resulted in formation of corunnine (65).⁷⁸

⁷³ M. Leboeuf and A. Cavé, *Phytochemistry*, 1972, **11**, 2833.

⁷⁴ B. Talapatra, P. Mukhopadhyay, and L. N. Dutta, *Phytochemistry*, 1975, **14**, 589.

⁷⁵ R. Huls, *Bull. Soc. roy. Sci. Liège*, 1972, **41**, 686 (*Chem. Abs.*, 1973, **79**, 15841).

⁷⁶ F. Baralle, N. Schvarzberg, M. J. Vernengo, G. Y. Moltrasio, and D. Giacobello, *Phytochemistry*, 1973, **12**, 948.

⁷⁷ L. D. Yakhontova, V. I. Sheichenko, and O. N. Tolkachev, *Khim. prirod. Soedinenii*, 1972, 214; *Chem. Natural Compounds*, 1974, 212.

⁷⁸ L. Castedo, R. Suau, and A. Mouriño, *Heterocycles*, 1975, **3**, 449.

7 Dioxoaporphines, Aristolactams, and Aristolochic Acids

Aristolochic acids and aristolactams possess skeleta (66) and (67), respectively, and are often found in the same plant. The aristolochic acids are among the small group of natural products incorporating a nitro-function.⁸¹ Compounds belonging to these two classes are non-basic, but can nevertheless be classified as alkaloids since they are derived from *in vivo* oxidation of aporphines. The last review on this dual topic appeared in 1961.⁸²

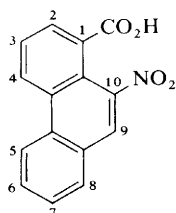

(66)

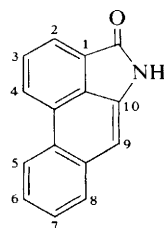

(67)

Aristolochic acids and aristolactams presently known and characterized, together with their sources, include (68)—(83).

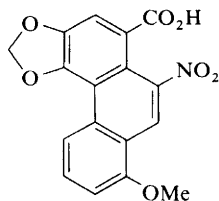

Aristolochic acid (68)^{81,83}
Aristolochia spp.^{82,84}
Asarum canadense
var. *reflexum*⁸⁵

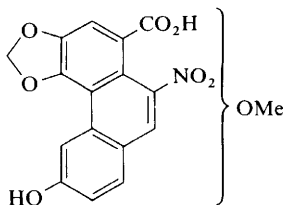

Aristolochic acid-B (69)
Aristolochia debilis
Sieb. et Zucc.^{86,87}

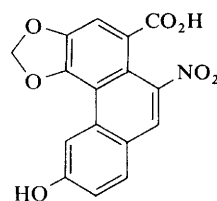

Aristolochic Acid-C (70)
Aristolochia debilis
Sieb. et Zucc.^{86,87}

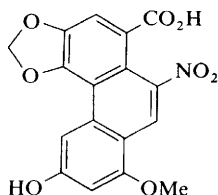

Aristolochic acid-D (71)
(aristolochic acid-IVa)
Aristolochia indica L.⁸⁴
A. clematitis L.⁸⁸

⁷⁹ I. Ribas, J. Sáa, and L. Castedo, *Tetrahedron Letters*, 1973, 3617.

⁸⁰ S. M. Kupchan and P. F. O'Brien, *J.C.S. Chem. Comm.*, 1973, 915.

⁸¹ S. M. Kupchan and H. C. Wormser, *J. Org. Chem.*, 1965, **30**, 3792.

⁸² H.-G. Boit, 'Ergebnisse der Alkaloide-Chemie bis 1960', Akademie Verlag, Berlin, 1961, pp. 281-284.

⁸³ M. Pailer, L. Belohlav, and E. Simonisch, *Monatsh.*, 1956, **87**, 249.

⁸⁴ S. M. Kupchan and J. J. Merianos, *J. Org. Chem.*, 1968, **33**, 3735.

⁸⁵ R. W. Doskotch and P. W. Vanevenhoven, *Lloydia*, 1967, **30**, 141.

⁸⁶ M. Tomita and S. Sasagawa, *J. Pharm. Soc. Japan*, 1959, **79**, 973, 1470.

⁸⁷ S. Sasagawa, *J. Pharm. Soc. Japan*, 1959, **82**, 921.

⁸⁸ E. A. Rúveda, S. M. Albonico, H. A. Priestan, V. Deulofeu, M. Pailer, E. Gössinger, and P. Berethaller.

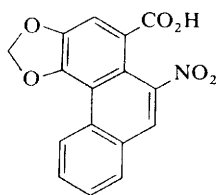

Aristolochic acid-II (72)
Aristolochia clematitis L.⁸⁹

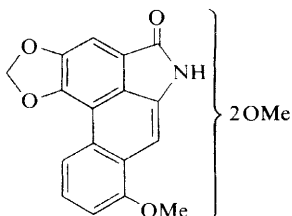

Aristo-red (73)⁹⁰
Aristolochia reticulata

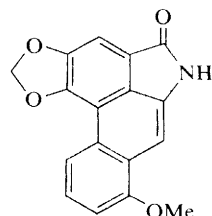

Aristolactam (74)
Aristolochia debilis
Sieb. et Zucc.^{86,87}
Aristolochia indica L.⁸⁴

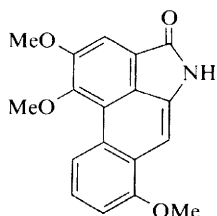

Taliscanine (75)
*Aristolochia taliscana*⁹¹

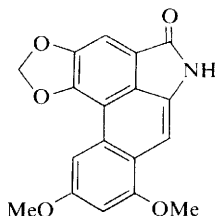

Aristolochic acid-D
methyl ester lactam (76)
Aristolochia indica L.⁸⁴

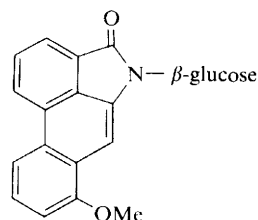

Aristolactam β -D-glucoside (77)
Aristolochia indica L.⁸⁴

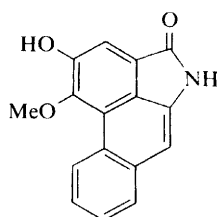

Aristolactam-AII (78)
*Aristolochia argentina*⁹²

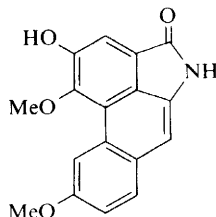

Aristolactam-AIII (79)
*Aristolochia argentina*⁹²

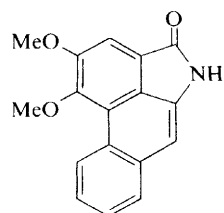

Aristolactam-BII (80)
(cepharanone-B)
*Aristolochia argentina*⁹²
Stephania cepharantha
Y. Hayata⁴

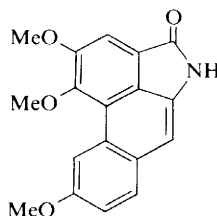

Aristolactam-BIII (81)
*Aristolochia argentina*⁹²

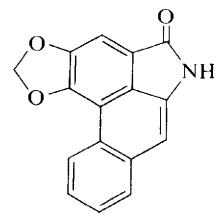

Cepharanone-A (82)
Stephania cepharantha
Y. Hayata⁴

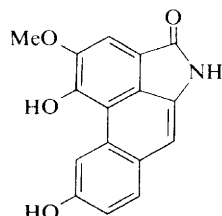

Doryflavine (83)
Doryphora sassafras Endlicher³⁸

⁸⁹ M. Pailer and A. Schleppechnik, *Monatsh.*, 1958, **89**, 175.

⁹⁰ R. T. Coutts, J. B. Stenlake, and W. D. Williams, *J. Chem. Soc.*, 1957, 4120.

⁹¹ L. A. Maldonado, J. Herran, and J. Romo, *Ciencia*, 1966, **24**, 237 (*Chem. Abs.*, 1966, **65**, 15 438e).

⁹² R. Crohare, H. A. Priestap, M. Farina, M. Cedola, and E. A. Ruveda, *Phytochemistry*, 1974, **13**, 1957.

Of these alkaloids, aristolactams -AII (78) and -BII (80), as well as cepharanone-A (82) and doryflavine (83), have been characterized recently, with the structural assignment for doryflavine being only tentative. Noteworthy is the fact that cepharanone-A (82) and aristolactam-BII (80) were found in *Stephania cepharantha* Y. Hayata (Menispermaceae),⁴ and that doryflavine (83) was isolated from *Doryphora sassafras* Endlicher (Monimiaceae).³⁸ These are the first recorded occurrence of aristolactams outside the family Aristolochiaceae.

There is a possibility that Tomita's aristolochic acid-B (69) may correspond to aristolochic acid-D (71).

A recent synthesis of an aristolactam involves nitration at C-10 of the ester (84) derived from glaucine, followed by catalytic reduction and lactamization to provide (85).⁹³

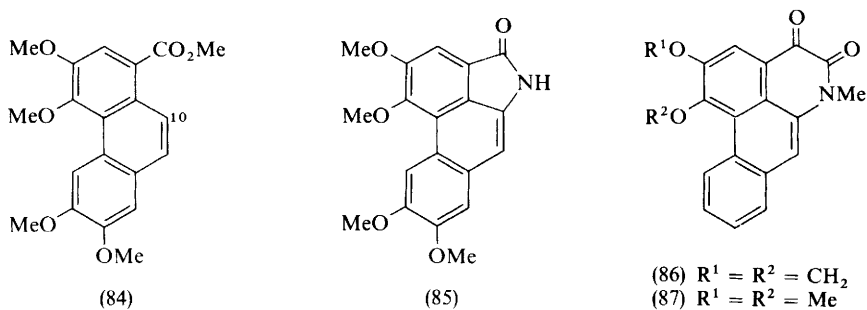

The orange-coloured cepharadione-A (86) and cepharadione-B (87) are unusual in that they are aporphinoids oxidized at both C-4 and C-5.⁴ They can be classified best as dioxoaporphines, *i.e.* derivatives of 4,5-dioxodibenzo[*de,g*]quinoline.

The biosynthesis of aristolochic acid (68) in *Aristolochia siphon* has been studied.⁹⁴ Tyrosine, dopa, dopamine, and, interestingly enough, noradrenaline serve as precursors, and the nitro-group of aristolochic acid is derived from the amino-group of tyrosine. It is most likely that aristolochic acid is formed by oxidation of a 1,2,8-trisubstituted aporphine.⁹⁴

The exact relationship between dioxoaporphines, aristolactams, and aristolochic acids still remains to be clarified. One possibility is for a 1,2,4-trioxygenated aporphine to be oxidized to a dioxoaporphine such as cepharadione-A (86), which can undergo net overall decarbonylation to yield cepharanone-A (82). Further oxidation of the latter would then give rise to aristolochic acid-II (72).⁶⁵ Significantly, cepharadione-A (86) and cepharanone-A (82), as well as cepharadione-B (87) and aristolactam-BII (80), are all found in the same plant.⁴ Furthermore, it should be noted that the two dioxoaporphines known are unsubstituted on ring D, and that aristolactams as well as aristolochic acids are never oxygenated at C-7. This common structural feature may well indicate a dienol-benzene rearrangement of a proaporphinol as part of the biogenetic sequence leading to dioxoaporphines, aristolactams, and aristolochic acids.⁶⁵

⁹³ P. Gorecki and H. Otta, *Pharmazie*, 1975, **30**, 337.

⁹⁴ F. Comer, H. P. Tiwari, and I. D. Spenser, *Canad. J. Chem.*, 1969, **47**, 481.

Aristolochic acid (68) has significant activity against certain neoplasms such as adenocarcinoma-755, but it also has undesirable nephrotoxic effects. The compound has been implicated as a probable causative agent in Balkan endemic nephropathy. A convenient fluorometric assay for aristolochic acid has been developed, based on hydrosulphite reduction to the lactam and measurement of the intensity of fluorescence.⁹⁵

8 Phenanthrenes

Phenanthrene alkaloids belong to the aporphinoid grouping since they must be formed through Hofmann elimination of quaternary aporphinium salts.⁹⁶ Recently discovered phenanthrenes include argentinine (88) found in *Aristolochia argentina* Gris;⁹⁷ uvariopsine (89), present in *Uvariopsis solheidii* and *U. guineensis*; 8-methoxyuvariopsine (90), uvariopsamine (91), noruvariopsamine (92), and uvariopsamine *N*-oxide (93), all found in *U. guineensis*;⁷³ thalflavidine (94) isolated from *Thalictrum flavum* L.;⁹⁸ and thaliglucine methochloride (95) as well as thaliglucinone methochloride (96), present in *T. polygamum* Muhl.²⁷

The structure (97) assigned to thalixine (thalicsine)⁹⁹ is biogenetically untenable since phenanthrenes originate from aporphines, and no aporphines are known to be unsubstituted at C-2, corresponding to position C-3 on the phenanthrene nucleus.

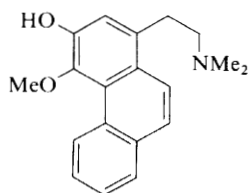

(88)

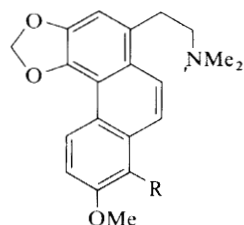
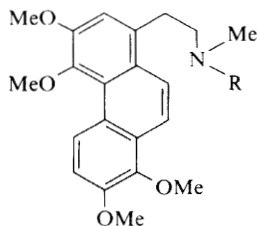
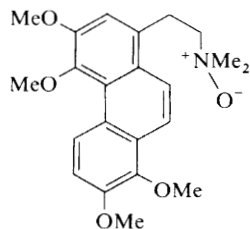
(89) R = H
(90) R = OMe(91) R = Me
(92) R = H

(93)

⁹⁵ K. V. Rao, Y. Tanrikut, and K. Killion, *J. Pharm. Sci.*, 1975, **64**, 345.

⁹⁶ For a previous review on the phenanthrene alkaloids see M. Shamma, 'The Isoquinoline Alkaloids', Academic Press, New York, 1975, p. 260.

⁹⁷ H. A. Priestap, E. A. Ruveda, S. M. Albonico, and V. Deulofeu, *Anales Asoc. quim. argentina*, 1972, **60**, 309; *Chem. Comm.*, 1967, 754.

⁹⁸ Kh. S. Umarov, Z. F. Ismailov, and S. Yu. Yunusov, *Khim. prirod. Soedinenii*, 1973, 683; *Chem. Natural Compounds*, 1975, 660.

⁹⁹ V. G. Khodzhaev, S. K. Maekh, and S. Yu. Yunusov, *Khim. prirod. Soedinenii*, 1973, 441; *Chem. Natural Compounds*, 1975, 421.

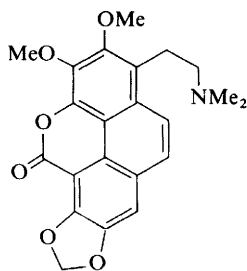

(94)

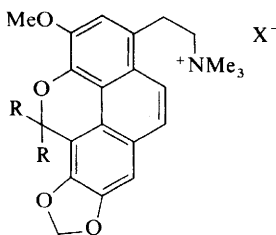

(95) R = H

(96) R + R = O

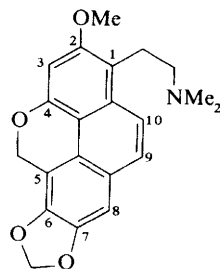

(97)

The synthesis of thaliglucine and thaliglucinone [*N*-demethyl-(95) and -(96) respectively] has been achieved through the preparation of (\pm)-thalphenine iodide [racemic (98)] followed by Hofmann elimination.⁴⁹ Thaliglucinone has shown antimicrobial activity.^{99a}

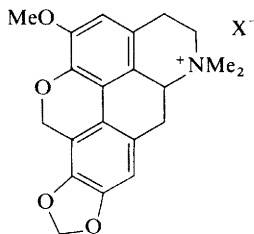

(98)

9 Azafluoranthenes

The unusual alkaloids imeluteine (99) and rufescine (100), found in *Abuta imene* and *A. rufescens*,¹⁰⁰ probably originate biogenetically from decarbonylation of oxoaporphine precursors.⁶⁵ Such an *in vivo* pathway is supported by the observation that *Abuta imene* also produces the oxoaporphine homomoschatoline (1,2,3-trimethoxyoxoaporphine).¹⁰¹ It is unlikely, on the other hand, that azafluoranthenes are produced by intramolecular phenolic coupling of 1-phenylbenzylisoquinolines. The only 1-phenylbenzylisoquinoline alkaloids known, namely the three cryptostylinines,¹⁰² are found only in the family Orchidaceae, where other isoquinolines, such as benzylisoquinolines, aporphines, oxoaporphines, and azafluoranthenes, are conspicuously absent.⁶⁵

In a study of the Pschorr reaction, it was found that amine (101), upon diazotization and Pschorr reaction, gave phenylisoquinolines (103) and (105), while under similar conditions amine (102) provided the nitrated dihydroazafluoranthene (106) in addition to (104).¹⁰³

^{99a} L. A. Mitscher, 'Recent Advances in Phytochemistry', ed. V. C. Runeckles, Plenum Press, New York and London, 1975, Vol. 9, pp. 264, 265.

¹⁰⁰ M. P. Cava, K. T. Buck, and A. I. da Rocha, *J. Amer. Chem. Soc.*, 1972, **94**, 5931.

¹⁰¹ M. P. Cava, personal communication, 1972.

¹⁰² For a review on the cryptostylinines, see ref. 103, p. 490.

¹⁰³ T. Kametani and S. Shibuya, *Heterocycles*, 1975, **3**, 439.

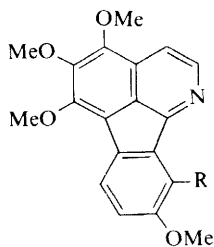

(99) R = OMe
(100) R = H

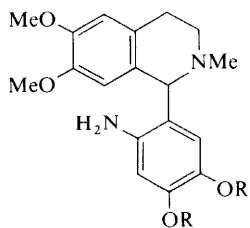

(101) R + R = CH₂
(102) R = Me

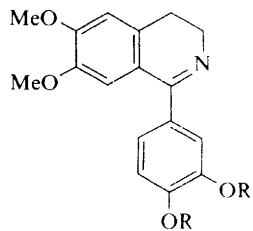

(103) R + R = CH₂
(104) R = Me

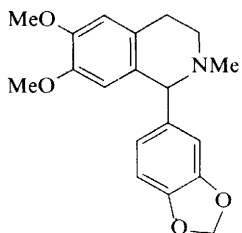

(105)

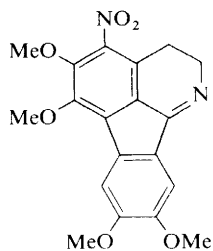

(106)

1 Introduction

In this Report the order of discussion of the various groups of indole alkaloids closely follows that adopted¹ by the reviewer's predecessor in Vol. 5.

Several reviews of general interest have been published or have become available during the last twelve months. Yunusov² has enumerated the contributions of Russian chemists in general, and the Tashkent Institute in particular, to alkaloid chemistry; these include, of course, some substantial contributions in the indole alkaloid area. Scott³ has reviewed biogenetic-type syntheses of indole alkaloids and Winterfeldt⁴ has discussed the most notable stereoselective total syntheses of indole alkaloids in the period from Woodward's strychnine synthesis in 1954 until 1972. In a two-part work which is the first in a series concerned with progress in mass spectrometry Hesse⁵ discusses the mass spectrometric behaviour of the indole alkaloids. Schlittler⁶ has contributed a further essay on the biogenetic and structural relationships in the indole alkaloid area. More restricted surveys include one on the β -carboline alkaloids,⁷ another on the synthesis of some isoquinoline and yohimbinoid alkaloids by thermolysis,^{8a} and one (for the Japanese reader) on the synthesis of oxindole alkaloids.^{8b} In yet more specific areas the *Rhazya* alkaloids have been reviewed⁹ and the complex problem of the taxonomy of the *Vinca* genus and, in particular, the position in the genus of *V. libanotica* Zucc. have been discussed in the light of the alkaloid content of the various species and sub-species.¹⁰ An article on alkaloids present in grazing and herbage includes reference to the simple indole alkaloids of the Graminae and Leguminosae.¹¹

¹ (a) J. A. Joule, in 'The Alkaloids', ed. J. E. Saxton (Specialist Periodical Reports), The Chemical Society, London, 1975, Vol. 5, Chapter 11; (b) *ibid.*, p. 215; (c) p. 213; (d) p. 214.

² S. Yu. Yunusov, 'Alkaloids Handbook', 2nd Edn., Fan, Tashkent, Uz.S.S.R., 1974.

³ A. I. Scott, *Bio-organic Chemistry*, 1974, **3**, 398.

⁴ E. Winterfeldt, *Fortschr. Chem. Org. Naturstoffe*, 1974, **31**, 469.

⁵ M. Hesse, 'Indolalkaloide (Teil 1: Text. Teil 2: Spektren)', *Fortschritte der Massenspektrometrie*, Band 1 and 2, Verlag Chemie, Weinheim, 1974.

⁶ E. Schlittler, *Pharm. Acta Helv.*, 1974, **49**, 235.

⁷ K. Stuart and R. Woo-Ming, *Heterocycles*, 1975, **3**, 223.

⁸ (a) T. Kametani and K. Fukumoto, *Heterocycles*, 1975, **3**, 29; (b) T. Ohoishi, *Yuki Gosei Kagaku Kyokai Shi*, 1974, **32**, 849.

⁹ A. Chatterjee, J. Banerji, and A. Banerji, *J. Indian Chem. Soc.*, 1974, **51**, 156.

¹⁰ G. H. Aynilian, N. R. Farnsworth, and J. Trojanek, in 'Chemistry in Botanical Classification', ed. G. Bendz and J. Santesson (Nobel Symposia on Medicine and Natural Sciences), Academic Press, New York, 1974, Vol. 25, pp. 189-204.

¹¹ C. C. J. Culvenor in 'Chemistry and Biochemistry of Herbage', ed. G. W. Butler and R. W. Bailey, Academic Press, New York, 1973, Vol. 1, p. 375.

2 Simple Alkaloids

Non-tryptamines.—Details of the synthesis of 6-(3-methylbuta-1,3-dienyl)indole, a constituent of *Monodora tenuifolia*,¹² have been published;¹³ the same paper also records the synthesis of 6-(3-methyl-2-butenyl)indole, one of two indole alkaloids of *Riccardia sinuata*.¹⁴

In the carbazole series it has been shown that the stem bark of *Murraya koenigii* Spreng contains racemic mahanimbine.¹⁵ A new alkaloid, indizoline (1), occurs¹⁶ in the roots of *Clausena indica* Oliv., together with 3-methylcarbazole, and the previously isolated 6-methoxyheptaphylline. The u.v. spectrum of indizoline, reminiscent of that of 3-formylcarbazole, the presence of an isopentenyl group (n.m.r.) and the resemblance of the u.v. spectrum of its Huang–Minlon reduction product to that of 1-methoxycarbazole, suggest that it is an isopentenyl derivative of 3-formyl-1-methoxycarbazole. The isopentenyl group is presumably situated at position 2, since the signal for the C-4 proton is a singlet only, at δ 8.4. The structure (1) was subsequently confirmed by synthesis of its Huang–Minlon reduction product (2) (Scheme 1).

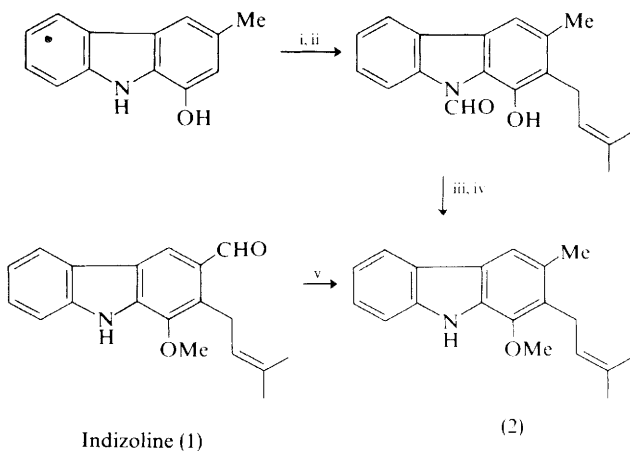

Reagents: i, HCO_2H ; ii, $\text{Me}_2\text{C}(\text{OH})\text{CH}:\text{CH}_2-\text{BF}_3, \text{EtO}$; iii, $\text{Me}_2\text{SO}_4-\text{K}_2\text{CO}_3-\text{Me}_2\text{CO}$; iv, $\text{EtOH}-\text{HCl}$; v, Huang–Minlon reduction.

Scheme 1

1,5-Dimethoxygramine (3), which occurs naturally in *Gymnocrantheria paniculata*,¹⁷ has been synthesized by a new general route to 1-methoxyindoles (Scheme 2).¹⁸

¹² M. N. Nwaji, S. O. Onyiriuka, and D. A. H. Taylor, *J.C.S. Chem. Comm.*, 1972, 327.

¹³ H. Ishii and Y. Murakami, *Tetrahedron*, 1975, **31**, 933.

¹⁴ V. Benešová, Z. Samek, V. Herout, and F. Šorm, *Coll. Czech. Chem. Comm.*, 1969, **34**, 1807.

¹⁵ S. Roy and D. P. Chakraborty, *Phytochemistry*, 1974, **13**, 2893.

¹⁶ B. S. Joshi and D. H. Gawad, *Indian J. Chem.*, 1974, **12**, 437.

¹⁷ S. R. Johns, J. A. Lambertson, and J. L. Occolowitz, *Austral. J. Chem.*, 1967, **20**, 1737.

¹⁸ R. M. Acheson, D. M. Littlewood, and H. E. Rosenberg, *J.C.S. Chem. Comm.*, 1974, 671.

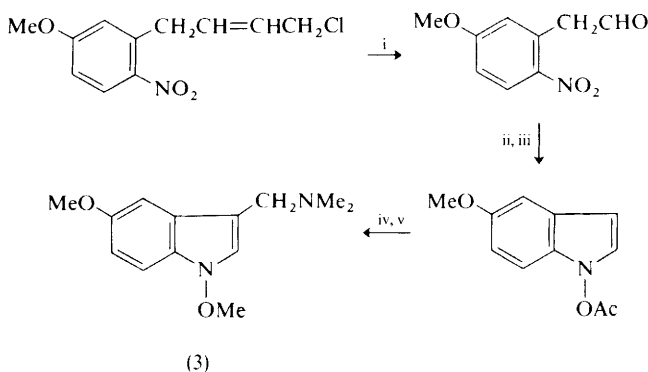

Reagents: i, OsO_4 - NaIO_4 ; ii, $\text{Zn-NH}_4\text{Cl}$; iii, acetylation; iv, NaOMe-MeOH ; v, $\text{CH}_2\text{O-Me}_2\text{NH}$.

Scheme 2

Non-isoprenoid Tryptamines.—Tryptamine and N_b -acetyltryptamine have been isolated from the leaves of the Argentinian tree *Prosopis nigra* (Gris.) Hieron;¹⁹ the latter has not previously been obtained from natural sources. N_b -Methyltryptamine occurs in the bark of the Brazilian tree *Nectandra megapotamica* (Sprg.) Chodat et Hassler,²⁰ and N -(p -coumaryl)tryptamine (4) in the mature kernels of sweet corn (*Zea mays*).²¹ The methyl ester of NN -dimethyl- L -tryptophan is among the tryptophan derivatives encountered recently; it occurs in jequirity seeds (*Abrus precatorius*), and may well be the plant-growth inhibitor known to be present.²² Hypaphorine (lenticin) has been isolated from lentil seedlings (*Lens culinaris*),²³ but a much more interesting tryptophan derivative is the erysophine ester of hypaphorine,

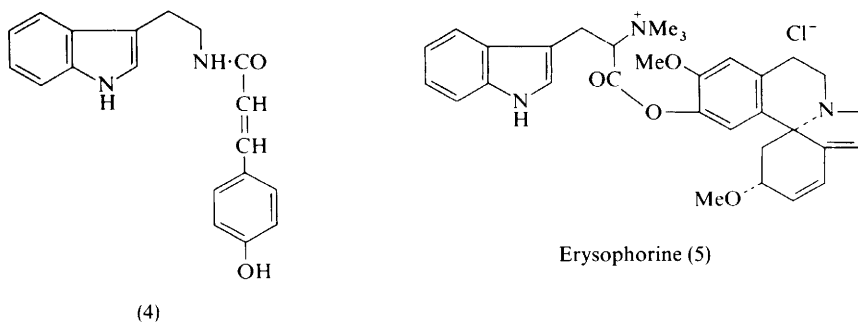

erysophorine (5), which occurs in the seeds of *Erythrina arborescens* Roxb., together with hypaphorine and eleven typical *Erythrina* alkaloids.²⁴ This is the first example of a hypaphorine ester in the *Erythrina* group. Traces of 5-hydroxytryptamine have

¹⁹ G. A. Moro, M. N. Graziano, and J. D. Coussio, *Phytochemistry*, 1975, **14**, 827.

²⁰ D. dos Santos Filho and B. Gilbert, *Phytochemistry*, 1975, **14**, 821.

²¹ A. Ehmann, *Phytochemistry*, 1974, **13**, 1979.

²² N. Mandava, J. D. Anderson, and S. R. Dutky, *Phytochemistry*, 1974, **13**, 2853.

²³ M. Hofinger, X. Monseur, M. Pais, and F. X. Jarreau, *Phytochemistry*, 1975, **14**, 475.

²⁴ S. Ghosal and R. S. Srivastava, *Phytochemistry*, 1974, **13**, 2603.

been found in callus tissues of *Peganum harmala*, and 6-hydroxytryptamine has been isolated from the seeds, seedlings, and callus tissues.²⁵ Bufotenine and its *O*-methyl ether have been isolated from samples of the hallucinogenic snuff drug *yopo* obtained from the Pixaasi-Teri tribe of the Rio Mavaca region in the upper Orinoco.²⁶ The isolation of bufotenine is consistent with the use of *Piptadenia peregrina* seeds in the preparation of the snuff, but the isolation of its *O*-methyl ether as single alkaloid from one sample suggests that the bark of a *Viola* species, possibly *V. theiodora*, was the main ingredient in this sample.

Studies on known alkaloids include one on the AA'BB' system and the conformational populations of tryptamine and some *N*-substituted derivatives,²⁷ and X-ray crystal structure analyses of psilocybin^{28a} and psilocin.^{28b} In connection with the separation and identification of tryptamine derivatives in the cerebrospinal fluid of schizophrenic patients the g.l.c. analysis of the heptafluorobutyryl derivatives is recommended; success is claimed on picogram quantities of material.²⁹

In the β -carboline series harman has been identified in, or isolated from, *Prosopis nigra*,¹⁹ *Burkea africana*,^{30a} *Pauridiantha lyallii*,^{31a} *Passiflora coerulea*, *P. decaisneana*, *P. edulis*, *P. foetida*, *P. incarnata*, *P. subpelata*, and *P. warmingii*,^{31b} in *Palicourea alpina* (Sw.) DC.^{32a} and *Ochrosia nakaiana* Koidz.^{32b} Tetrahydroharman (eleagnine) occurs in *Prosopis nigra*¹⁹ and *Burkea africana*,^{30a,b} the latter also contains harmalan and possibly harmalan N_6 -oxide.^{30a} New constituents of *Peganum harmala* include harmol and dihydroruine (8-glucosyloxyharmaline) in the seedlings and callus tissue.²⁵ The bark of *Nectandra megapotamica* contains 6-methoxy- N_6 -methyl-1,2,3,4-tetrahydrocarboline,²⁰ which has been synthesized, apparently for the first time, by a conventional Pictet-Spengler synthesis *via* 6-methoxy- β -carboline.³³

An interesting example of asymmetric induction has been utilized in a new biogenetic-type synthesis of (–)-tetrahydroharman and (–)-1,2,3,4,6,7,12,12b-octahydroindol[2,3-*a*]quinolizine (6) from L-tryptophan,³⁴ the synthesis of (6) is outlined in Scheme 3. Apparently the Pictet-Spengler closure is stereospecific, and affords the 1,3-*cis* stereoisomer (6a); removal of the unwanted chiral centre is achieved in good yield and without epimerization at C-1 by NaBH₄ reduction of an α -aminonitrile. This synthesis may well find application in other areas. The alkaloid (6) has also been synthesized by a more conventional, non-stereospecific route.³⁵

²⁵ E. McKenzie, L. Nettleship, and M. Slaytor, *Phytochemistry*, 1975, **14**, 273

²⁶ J. De Budowski, G. B. Marini-Bettòlo, F. D. Monache, and F. Ferrari, *Farmaco (Pavia)*, Ed. Sci., 1974, **29**, 574.

²⁷ C. C. J. Culvenor and N. S. Ham, *Austral. J. Chem.*, 1974, **27**, 2191.

²⁸ (a) H. P. Weber and T. J. Petcher, *J.C.S. Perkin II*, 1974, 942; (b) T. J. Petcher and H. P. Weber, *ibid.*, p. 946.

²⁹ F. Benington, S. T. Christian, and R. D. Morin, *J. Chromatog.*, 1974, **106**, 435.

³⁰ (a) M. A. Ferreira, *Garcia de Orta, Ser. Farmacogn.*, 1973, **2**, 33 (*Chem. Abs.*, 1974, **81**, 166 304); (b) *ibid.*, p. 7 (*Chem. Abs.*, 1974, **81**, 166 303).

³¹ (a) J. L. Pousset, J. Levesque, A. Cavé, F. Picot, P. Potier, and R. R. Paris, *Plant. Med. Phytother.*, 1974, **8**, 51 (*Chem. Abs.*, 1974, **81**, 117 054); (b) J. Loehdefink and H. Kating, *Planta Med.*, 1974, **25**, 101 (*Chem. Abs.*, 1974, **81**, 35 531).

³² (a) K. L. Stuart and R. B. Woo-Ming, *Tetrahedron Letters*, 1974, 3853; (b) S. Sakai, N. Aimi, K. Takahashi, M. Kitagawa, K. Yamaguchi, and J. Haginiwa, *Yakugaku Zasshi*, 1974, **94**, 1274.

³³ J. L. Frahn and R. J. Illman, *Austral. J. Chem.*, 1974, **27**, 1367.

³⁴ H. Akimoto, K. Okamura, M. Yui, T. Shiroyi, M. Kuramoto, Y. Kikugawa, and S. Yamada, *Chem. and Pharm. Bull. (Japan)*, 1974, **22**, 2614.

³⁵ M. Nakagawa, M. Kiuchi, M. Obi, M. Tonzuka, K. Kobayashi, T. Hino, and Y. Ban, *Chem. and Pharm. Bull. (Japan)*, 1975, **23**, 304.

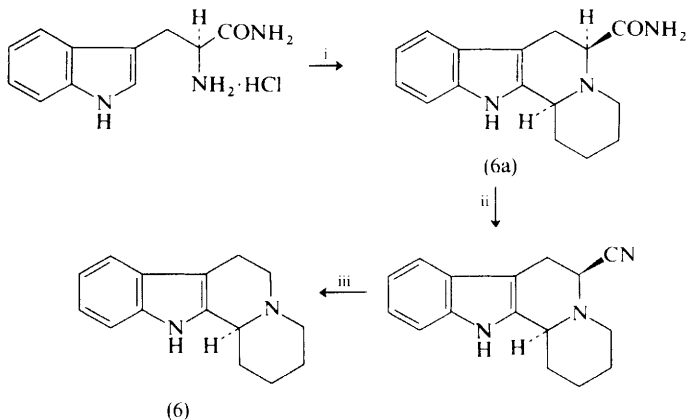

Reagents: i, $\text{Cl}(\text{CH}_2)_4\text{CHO}$, $\text{H}_2\text{O}-\text{MeOH}$; ii, $\text{POCl}_3-\text{C}_5\text{H}_5\text{N}-\text{DMF}$; iii, NaBH_4 , $\text{EtOH}-\text{C}_5\text{H}_5\text{N}$.

Scheme 3

The mass spectrum of (6) contains,³⁶ as expected, a major fragment at m/e 197. Deuteration experiments unexpectedly show, however, that only ca. 20% of this ion originates *via* a retro-Diels-Alder fission of ring D; instead, the ion appears to be mainly the result of a stepwise fragmentation of ring D (Scheme 4).

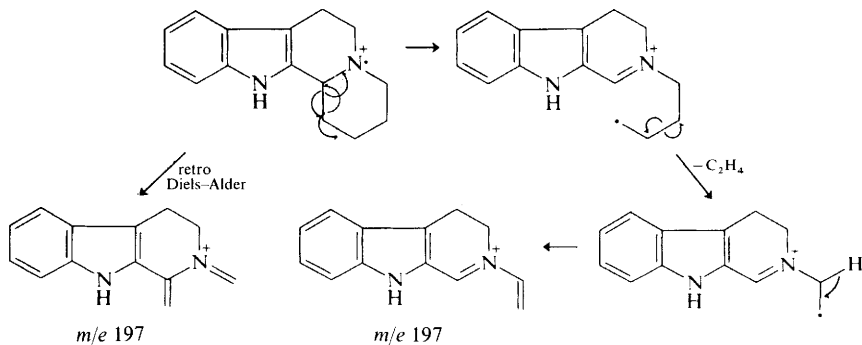

Scheme 4

Brevicarine (7) and brevicolline (8) have been interrelated by bromination of brevicarine, which affords 6,8-dibromobrevicarine, 1',6,8-tribromobrevicarine, and 6-bromobrevicolline (9), also obtainable by the direct bromination of brevicolline.^{37a}

The total synthesis^{37b} of N_a -methylbrevicolline (10) takes advantage of an ingenious new method for the synthesis of 4-substituted tetrahydro- β -carboline (Scheme

³⁶ G. W. Gribble and R. B. Nelson, *J. Org. Chem.*, 1974, **39**, 1845.

³⁷ (a) T. I. Shirshova, I. V. Terent'eva, G. V. Lazur'evskii, and V. M. Adanin, *Khim. geterotsikl. Soedinenii*, 1974, 1133 (*Chem. Abs.*, 1974, **81**, 152 482); (b) W. Müller, R. Preuss, and E. Winterfeldt, *Angew. Chem. Internat. Edn.*, 1975, **14**, 357; (c) E. Leete, M. R. Chedel, and G. B. Bodem, *J. Org. Chem.*, 1972, **37**, 4465.

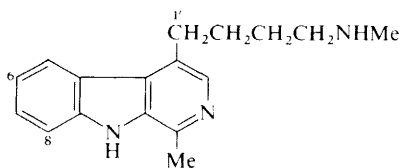

Brevicarinine (7)

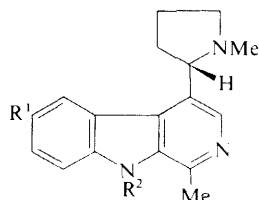

Brevicolline (8) $R^1 = R^2 = H$
 6-Bromobrevicolline (9) $R^1 = Br, R^2 = H$
 N_a -Methylbrevicolline (10) $R^1 = H, R^2 = Me$

5). The key steps in this synthesis are the direct formation of the substituted indole ester (11) by the acid-catalysed reaction of ethyl pyruvate with methylphenylhydrazine, the closure of the tetrahydro- β -carboline ring by reaction of (11) with

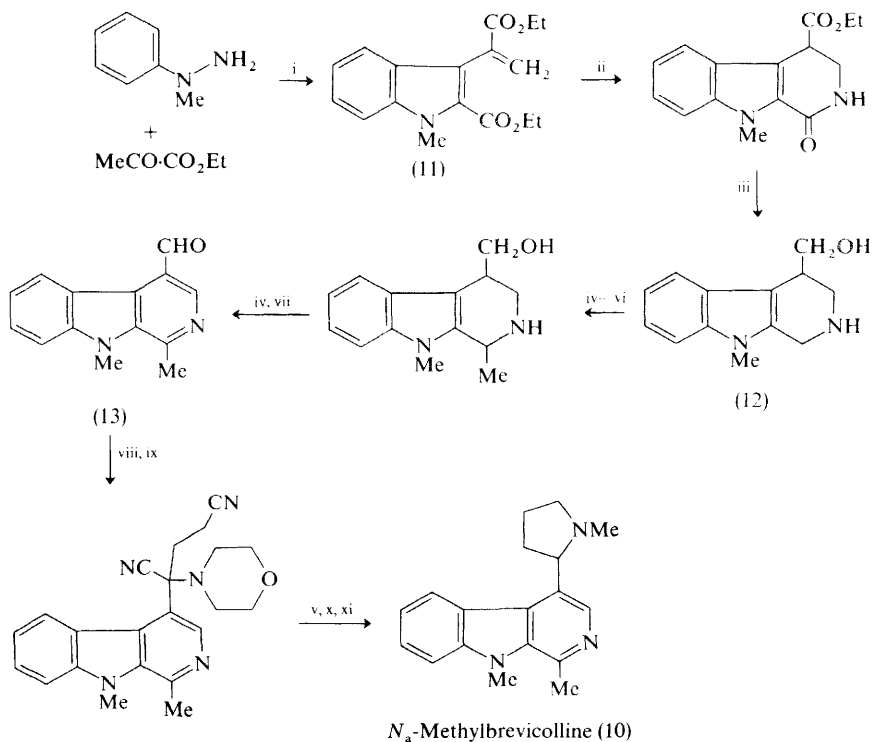

Reagents: i, H_2SO_4 -AcOH, N_2 , $<70^\circ C$; ii, NH_3 ; iii, $LiAlH_4$; iv, $Pb(OAc)_4$; v, H^+ ; vi, $MeMgI$; vii, MnO_2 ; viii, morpholine-CN $^-$; ix, $CH_2=CH-CN$; x, reductive cyclization; xi, $CH_2O-NaBH_3CN$.

Scheme 5

ammonia, the introduction of a substituent at position 1 by a Grignard reaction on the dihydro- β -carboline derived from (12), and the application of Leete's method^{37c} for the synthesis of pyrrolidine derivatives, utilizing the aldehyde (13).

A new synthesis³⁸ of desoxo eseroline (14) consists essentially in the formation of the carbinolamine (15) by a Fischer indole reaction on ethyl 3-formylbutyrate, for which a new preparation is reported. Three obvious stages then complete the synthesis (Scheme 6).

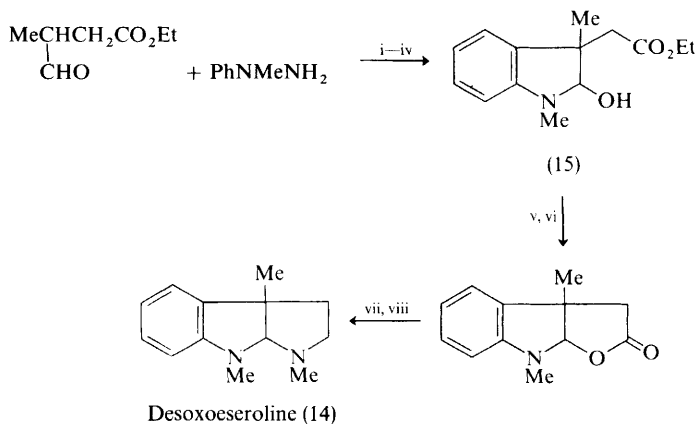

Reagents: i, SnCl_2 -EtOH-HCl, 0°C , 48 h; ii, HCl-MeOH- H_2O ; iii, H_2S ; iv, Na_2CO_3 ; v, MeOH-KOH; vi, HCl to pH 4; vii, MeNH_2 -MeOH; viii, LiAlH_4 .

Scheme 6

1-Hydroxyrutaecarpine (16) occurs in the bark of *Euxylophora paraënsis* Hub.^{39a} Its structure was established by methylation to its *N,O*-dimethyl derivative (17),

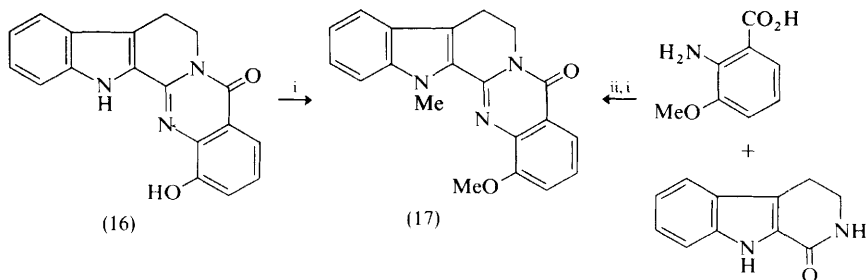

Reagents: i, MeI, K_2CO_3 ; ii, POCl_3 .

Scheme 7

which was conveniently synthesized from 2-oxo-1,2,3,4-tetrahydro- β -carboline and 3-methoxyanthranilic acid in the presence of phosphorus oxychloride, followed by *ind-N*-methylation of the product (Scheme 7). The unusually facile *ind-N*-methylation in the indolopyridoquinazoline series is obviously the consequence of stabilization of the derived anion by the quinazolone grouping.^{39b} Rutaecarpine-1-

³⁸ P. Rosenmund and A. Sotiriou, *Chem. Ber.*, 1975, **108**, 208.

³⁹ (a) B. Danieli, G. Palmisano, G. Rainoldi, and G. Russo, *Phytochemistry*, 1974, **13**, 1603; (b) B. Danieli and G. Palmisano, *Gazzetta*, 1975, **105**, 45.

carboxylic acid has also been synthesized, from 1-oxotetrahydro- β -carboline and 2-aminoisophthalic acid.⁴⁰

Cytochalasin G, the major active component of the culture filtrate of an unidentified *Nigrosabulum* species,⁴¹ has the structure (18); other indole metabolites in the culture filtrate have not yet been investigated. Cytochalasin G is the first example of an [11]-cytochalasin containing a 10-(indol-3-yl) group.

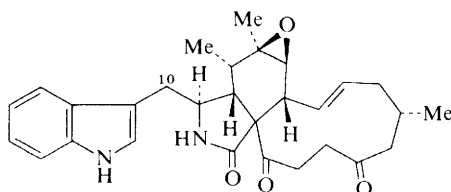

Cytochalasin G (18)

3 Isoprenoid Tryptamine and Tryptophan Alkaloids

Mould Metabolites.—In the search for later intermediates in the biosynthesis of echinulin and neochinulin three new prenylated indole derivatives have been isolated from the mycelium of *Aspergillus amstelodami*;^{42,43} these are neoechinulin A (19), neoechinulin B (20), and neoechinulin C (cryptoechinulin A) (21). The isolation of neoechinulin A lends credence to the proposal⁴⁴ that in the biosynthesis of echinulin the first isopentenyl group is introduced to position 2 of a preformed *cyclo*-alanyltryptophan system, while the isolation of (19)—(21) suggests that neoechinulin (22) may be formed by a dehydrogenation followed by oxidative fission of the alanyl methyl group ($\text{CHMe} \rightarrow \text{C}=\text{CH}_2 \rightarrow \text{C}=\text{O}$).⁴²

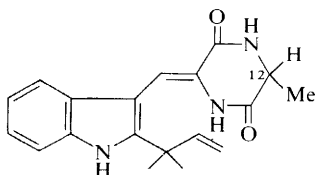

Neoechinulin A (19)

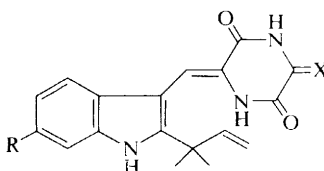

Neoechinulin B (20) R = H, X = CH₂
 Neoechinulin C (21) R = CH₂CH=CMe₂,
 X = CH₂
 Neoechinulin (22) R = CH₂CH=CMe₂,
 X = O

The structure (23) proposed for brevianamide A has been confirmed⁴⁵ by X-ray crystal structure analysis of its 5-bromo-derivative (24).

⁴⁰ K. Dóra-Horváth and O. Clauder, *Acta Pharm. Hung.*, 1974, **44**, 80 (*Chem. Abs.*, 1974, **81**, 136 348).

⁴¹ A. F. Cameron, A. A. Freer, B. Hesp, and C. J. Strawson, *J.C.S. Perkin II*, 1974, 1741.

⁴² A. Dossena, R. Marchelli, and A. Pochini, *J.C.S. Chem. Comm.*, 1974, 771.

⁴³ R. Cardillo, C. Fuganti, G. Gatti, D. Ghiringhelli, and P. Grasselli, *Tetrahedron Letters*, 1974, 3163.

⁴⁴ C. M. Allen, jun., *Biochemistry*, 1972, **11**, 2154.

⁴⁵ J. Coetzer, *Acta Cryst.*, 1974, **30B**, 2254.

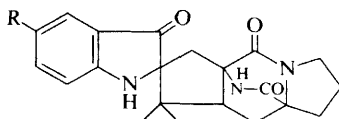

Brevianamide A (23) R = H
5-Bromobrevianamide A (24) R = Br

The major metabolite of *Penicillium italicum* Wehmer, which causes the familiar blue mould on citrus fruits, is deoxybrevianamide E (25);⁴⁶ a minor metabolite was shown to be 12,13-dehydrodeoxybrevianamide E, and a third metabolite is suspected to be (26), *i.e.* the indole analogue of austamide, although direct comparison with authentic material was not possible.

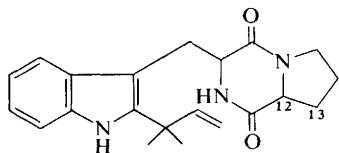

Deoxybrevianamide E (25)

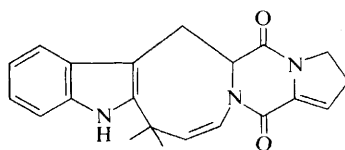

(26)

In recent years considerable interest has been shown in the tremorgenic toxins produced by various micro-organisms of the *Aspergillus* and *Penicillium* genera. The structure of fumitremorgin B (lanosulin) (27) was elucidated earlier,⁴⁷ and has now been confirmed by X-ray crystal structure analysis;⁴⁸ the isolation of L-proline following hydrolysis establishes the absolute configuration shown in (27). One of its three congeners in *Aspergillus fumigatus* Fres., fumitremorgin A (28), is a closely

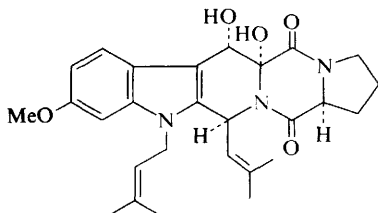

Fumitremorgin B (27)

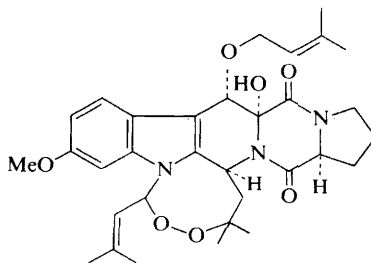

Fumitremorgin A (28)

related peroxide presumably obtained by oxidation and cyclization of fumitremorgin B dimethylallyl ether.^{49,50} X-Ray diffraction studies established the structure and relative stereochemistry of fumitremorgin A;⁴⁹ the absolute configuration depicted in (28) is assumed by analogy with fumitremorgin B. In consonance with this structure fumitremorgin A loses its *O*-dimethylallyl ether group on treatment with

⁴⁶ P. M. Scott, B. P. C. Kennedy, J. Harwig, and Y. K. Chen, *Applied Microbiology*, 1974, **28**, 892.

⁴⁷ M. Yamazaki, K. Sasago, and K. Miyaki, *J.C.S. Chem. Comm.*, 1974, 408.

⁴⁸ M. Yamazaki, H. Fujimoto, T. Akiyama, U. Sankawa, and Y. Iitaka, *Tetrahedron Letters*, 1975, 27.

⁴⁹ N. Eickman, J. Clardy, R. J. Cole, and J. W. Kirksey, *Tetrahedron Letters*, 1975, 1051.

⁵⁰ M. Yamazaki, H. Fujimoto, and T. Kawasaki, *Tetrahedron Letters*, 1975, 1241.

methanolic sulphuric acid, and gives rise to the methyl ether (29), which loses its isopentenyl group on hydrogenation, with formation of the tertiary alcohol (30) (Scheme 8).⁵⁰

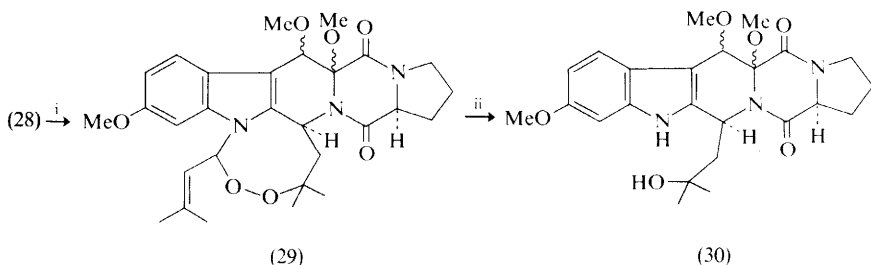

Reagents: i, MeOH-H₂SO₄; ii, H₂-PtO₂, CH₃CO₂Et.

Scheme 8

Fumitremorgin A may also be regarded as the *O*-dimethylallyl ether of verruculogen (31), a potent mycotoxin obtained from *Penicillium verruculosum* Peyronel isolated⁵¹ from peanuts, which produces severe tremors when administered orally to mice or day-old chicks. Again the structure and relative configuration were determined by *X*-ray crystal structure analysis. In view of the close structural relationship between verruculogen and fumitremorgin B it is perhaps not surprising that they should occur in the same micro-organism; both have recently been isolated from *Aspergillus caespitosus* cultures.⁵¹

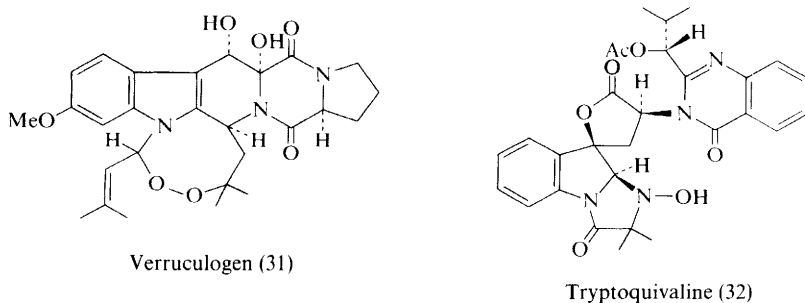

Two further tremorgenic metabolites, tryptoquivaline (32) and tryptoquivalone (33) have been isolated⁵² from *Aspergillus clavatus* collected from mould-damaged rice. This micro-organism has already yielded two non-toxic metabolites, kotanin and desmethylkotanin, and the highly toxic cytochalasin E.⁵³ The structure of tryptoquivaline, a γ -lactone, was elucidated by *X*-ray analysis of the *p*-bromophenylurethan (35) of its deacetyl derivative (34) which, in contrast, contains a δ -lactone grouping. N.m.r. data constituted the principal evidence for the structure

⁵¹ J. Fayos, D. Lokensgard, J. Clardy, R. J. Cole, and J. W. Kirksey, *J. Amer. Chem. Soc.*, 1974, **96**, 6785.

⁵² J. Clardy, J. P. Springer, G. Büchi, K. Matsuo, and R. Wightman, *J. Amer. Chem. Soc.*, 1975, **97**, 663.

⁵³ G. Büchi, D. H. Klaubert, R. C. Shank, S. M. Weinreb, and G. N. Wogan, *J. Org. Chem.*, 1971, **36**, 1143; G. Büchi, Y. Kitaura, S. S. Yuan, H. E. Wright, J. Clardy, A. L. Demain, T. Glinsukon, N. Hunt, and G. N. Wogan, *J. Amer. Chem. Soc.*, 1973, **95**, 5423.

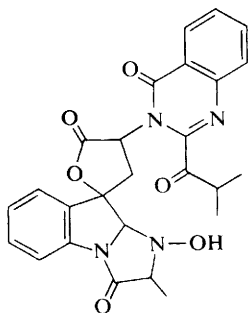

Tryptoquivalone (33)

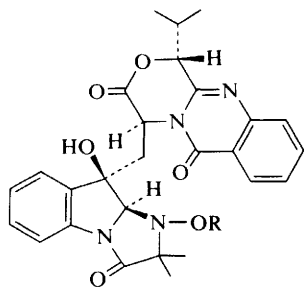

(34) R = H
 (35) R = Br  NHCO—

of tryptoquivalone (33). Both metabolites are clearly tetrapeptidic in character, tryptoquivaline being derived from tryptophan, anthranilic acid, valine, and methylalanine. Tryptoquivalone contains an alanine instead of a methylalanine component, and presumably has the same absolute configuration as tryptoquivaline at the asymmetric centres of common biogenetic origin.

The structure of oxaline (36), the principal alkaloid of a toxigenic strain of *Penicillium oxalicum*, represents a departure from those hitherto encountered in this area.⁵⁴ The molecule possesses several unusual features, viz. the N—OMe group, the dehydrohistidine unit, the reversed isopentenyl group at C-3 (the only other example known⁵⁵ to date is metabolite LL-S490 β), and the presence of three nitrogen functionalities attached to a single carbon atom (C-2).

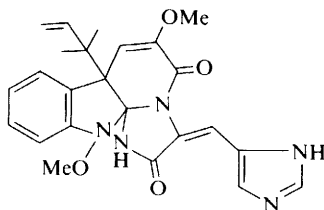

Oxaline (36)

Finally in this group, an unnamed tremorgenic metabolite, C₂₇H₃₃NO₄, containing an indole u.v. chromophore has been isolated from *P. paxilli*, but little information concerning its structure is yet available.⁵⁶

Ergot Alkaloids.—Three new clavine alkaloids have been isolated⁵⁷ from the saprophytic cultures of a strain of *Claviceps paspali* Stevens et Hall which produces as main metabolite 6-methyl- $\Delta^{8,9}$ -ergolen-8-carboxylic acid (37), together with chanoclavine-I, isochanoclavine-I, penniclavine, and elymoclavine. The new bases

⁵⁴ D. W. Nagel, K. G. R. Pachler, P. S. Steyn, P. L. Wessels, G. Gafner, and G. J. Kruger, *J.C.S. Chem. Comm.*, 1974, 1021.

⁵⁵ G. A. Ellestad, P. Miranda, and M. P. Kunstmann, *J. Org. Chem.*, 1973, **38**, 4204.

⁵⁶ R. J. Cole, J. W. Kirksey, and J. M. Wells, *Canad. J. Microbiol.*, 1974, **20**, 1159.

⁵⁷ H. Tschertler and H. Hauth, *Helv. Chim. Acta*, 1974, **57**, 113.

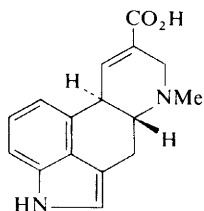

(37)

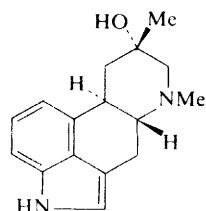

Dihydrosetoclavine-I (38)

are dihydrosetoclavine-I (38), and two bases of a new structural type, paspaclavine (39) and paliclavine (40). The gross structure of (39), and the relative stereochemistry at positions C-5, -9, and -10, were deduced mainly by n.m.r. spectroscopy; the absolute configuration depicted is assumed by analogy with the other ergot alkaloids.

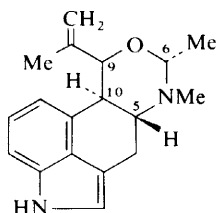

Paspoclavine (39)

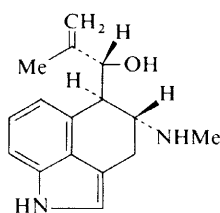

Paliclavine (40)

The configuration at C-6 follows from the behaviour of paspaclavine with acid; as an amino-acetal of acetaldehyde it suffers loss of acetaldehyde when treated with acid with formation of the third new alkaloid paliclavine (40), from which it can be re-synthesized by condensation with acetaldehyde.

An unidentified *Claviceps* strain (No. 178) growing parasitically on *Cynodon dactylon* (L.) Pers. (common Bermuda grass), which is used as a forage crop for cattle in several Southern States in the U.S.A., appears to be responsible for 'Bermuda grass tremors'. Extraction of the culture filtrates of this strain afforded⁵⁸ ergonovine (41), ergonovine (42), chanoclavine-I, and penniclavine (43).

Most of the *Ipomoea* species studied to date have been shown to contain ergoline derivatives. In a reinvestigation of the seeds of *I. violacea* chanoclavine, elymoclavine, penniclavine, and isolysergic acid amide have been identified.⁵⁹ The seeds of *I. muelleri* Benth., a toxic variety of morning glory from W. Australia, contain no less than 39 ergoline alkaloids, of which 20 have been identified.⁶⁰ Of these, setoclavine, isosetoclavine, α -dihydrolysergol, isopenniclavine, and molliclavine had not previously been encountered in *Ipomoea* species. Nine out of sixteen species (or varieties) of *Ipomoea* growing in India contain alkaloids;⁶¹ those identified include elymoclavine, setoclavine, and ergometrine in a sample of unknown botanical origin,

⁵⁸ J. K. Porter, C. W. Bacon, and J. D. Robbins, *J. Agric. and Food Chem.*, 1974, **22**, 838.

⁵⁹ U. Stanescu, E. Riscalcic, and E. Grigorescu, *Farmacia (Bucharest)* 1973, **21**, 719 (*Chem. Abs.*, 1974, **81**, 87 964).

⁶⁰ A. Der Marderosian, E. Cho, and J. M. Chao, *Planta Med.*, 1974, **25**, 6 (*Chem. Abs.*, 1974, **81**, 101 806).

⁶¹ S. K. Banerjee and S. P. Bhatnagar, *Indian J. Pharm.*, 1974, **36**, 44.

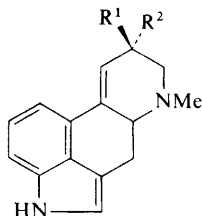

Ergonovine (41) $R^1 = \text{CONHCH}(\text{Me})\text{CH}_2\text{OH}$, $R^2 = \text{H}$

Ergonovinine (42) $R^1 = \text{H}$, $R^2 = \text{CONHCH}(\text{Me})\text{CH}_2\text{OH}$

Peniclavine (43) $R^1 = \text{CH}_2\text{OH}$, $R^2 = \text{OH}$

agroclavine (in *I. uniflora*), pyroclavine (in *I. quamoclit*), and ergotamine (in *I. quamoclit* and *Convolvulus major*). The hypotensive action of the seeds of *Argyrea speciosa* appears to be due to three alkaloids, two of which are reported to be unstable; the third was identified as ergometrine.⁶²

The trimethylsilyl derivative of agroclavine is recommended⁶³ for analytical determination by g.l.c.; in contrast to the trifluoroacetyl derivative, which gives complex, non-reproducible results the trimethylsilyl derivative is cleanly formed, and behaves satisfactorily on g.l.c. Further studies on the mass spectra of clavine alkaloids and lysergic acid derivatives have been reported.⁶⁴

The partial or total synthesis of ergot alkaloids continues to attract considerable attention. New partial syntheses include a conversion of lysergic acid into penniclavine and elymoclavine. The acetoxymercuration of methyl lysergate followed by reduction (NaBH_4) gives the conjugated ester (44), which on reduction by complex metal hydrides followed by treatment with aqueous acid affords peniclavine (43) (Scheme 9).^{65,66}

Two routes were adopted for the conversion of the allylic alcohol (45) into elymoclavine (46), and a procedure was worked out for the preparation from peniclavine of (+)-decarboxylysergic acid (47), previously known only as a racemate.⁶⁵ A Curtius reaction on the hydrazide from (44), followed by a Grignard reaction, resulted in a new synthesis of isosetoclavine (48) (Scheme 9).⁶⁶

Scheme 10 outlines the first recorded synthesis^{67a} of (\pm)-chanoclavine-I (50), which employs as essential starting material the ketone (49), prepared earlier.^{67b}

Agroclavine has been converted⁶⁸ into setoclavine and isosetoclavine by incubation with crude extracts of a *Claviceps* species. Since the two alkaloids were also produced following incubation with boiled crude *Claviceps* extracts (albeit in somewhat reduced yield), most of the conversion would appear to be non-enzymic.

⁶² S. K. Agarwal and R. P. Rastogi, *Indian J. Pharm.*, 1974, **36**, 118 (*Chem. Abs.*, 1975, **82**, 54 242).

⁶³ K. D. Barrow and F. R. Quigley, *J. Chromatog.*, 1975, **105**, 393.

⁶⁴ D. Voigt, S. John, and D. Gröger, *Pharmazie*, 1974, **29**, 697; J. Vokoun, P. Sajdl, and Z. Rehacek, *Zentralbl. Bakteriol., Parasitenkd., Infektionskr. Hyg., Abt. 2*, 1974, **129**, 499 (*Chem. Abs.*, 1975, **82**, 156 549).

⁶⁵ N. J. Bach and E. C. Kornfeld, *Tetrahedron Letters*, 1974, 3225.

⁶⁶ L. Bernardi, E. Gandini, and A. Temperilli, *Tetrahedron*, 1974, **30**, 3447.

⁶⁷ (a) H. Plieninger, W. Lehnert, S. Mangold, D. Schmalz, A. Völkl, and J. Westphal, *Tetrahedron Letters*, 1975, 1827; (b) H. Plieninger, W. Lehnert, and D. Mangold, *Chem. Ber.*, 1967, **100**, 2421.

⁶⁸ R. S. Bajwa and J. A. Anderson, *J. Pharm. Sci.*, 1975, **64**, 343.

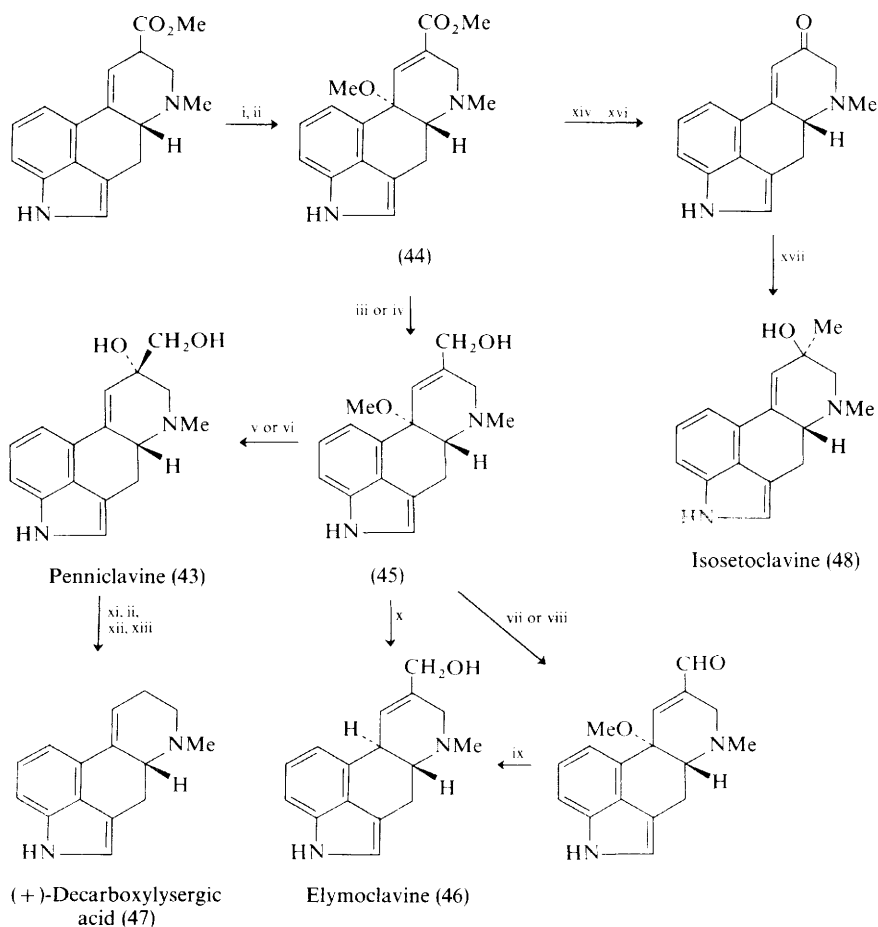

Reagents: i, $\text{Hg}(\text{OAc})_2\text{-MeOH}$; ii, NaBH_4 ; iii, $\text{NaAlH}_2(\text{OCH}_2\text{CH}_2\text{OMe})_2$; iv, LiAlH_4 ; v, 2% tartaric acid- H_2O ; vi, $\text{H}_2\text{SO}_4\text{-H}_2\text{O}$; vii, MnO_2 ; viii, DCC-DMSO-TFA ; ix, Zn-AcOH ; x, $\text{LiAlH}_4\text{-AlCl}_3$; xi, HIO_4 ; xii, acetylation; xiii, electrochemical reduction; xiv, $\text{H}_2\text{N-NH}_2\text{-H}_2\text{O-MeOH}$; xv, $\text{NaNO}_2\text{-HCl}$; xvi, C_6H_6 , 80°C , 2 h, then 0.2 M HCl ; xvii, MeMgBr .

Scheme 9

Monoterpenoid Alkaloids.—*Corynantheine-Heteroyohimbine-Yohimbine Group, and Related Oxindoles.* The first recorded extraction⁶⁹ of the leaves and twigs of *Peschiera laeta* Mart. has yielded geissoschizol, a base not previously found in the *Peschiera* genus. Antirhine and, to a lesser extent, its quaternary N_b -metho-derivative, occur in the bark of *Strychnos camptoneura* Gilg. et Busse⁷⁰ and in *Amsonia elliptica*,⁷¹ which also contains tetrahydrosecamine, pleiocarpamine,

⁶⁹ L. Jahodár, Z. Votický, and M. P. Cava, *Phytochemistry*, 1974, **13**, 2880.

⁷⁰ N. G. Bisset and J. D. Phillipson, *Phytochemistry*, 1974, **13**, 1265.

⁷¹ S. Sakai, H. Ohtani, H. Ido, and J. Haginiwa, *Yakugaku Zasshi*, 1973, **93**, 483.

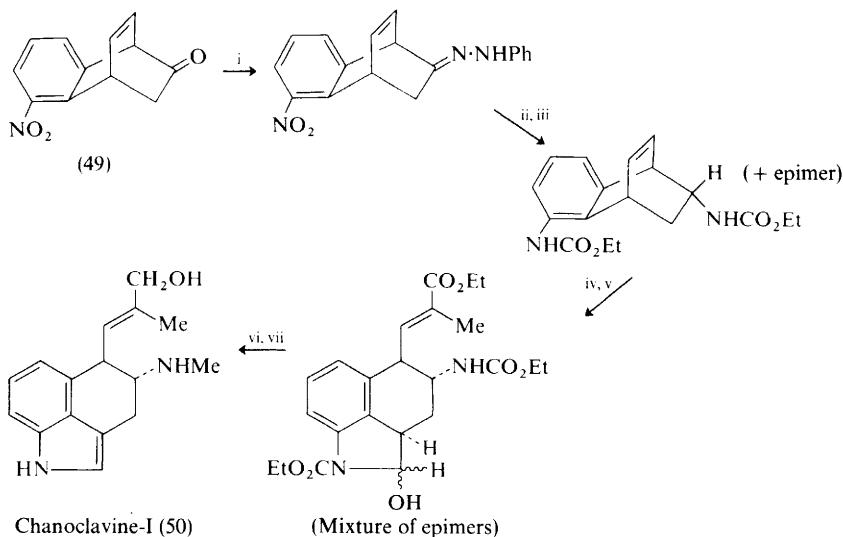

Reagents: i, PhNHNH_2 ; ii, $\text{Al-H}_2\text{O-EtOH}$; iii, ClCO_2Et ; iv, O_3 ; v, $\text{EtO}_2\text{CC(Me):PPh}_3$; vi, $(\text{CO}_2\text{H})_2\text{-AcOH}$; vii, LiAlH_4 .

Scheme 10

yohimbine, β -yohimbine, 3,4,5,6-tetrahydroyohimbinium chloride, and 10-hydroxygeissoschizol. Antirhine β -metho-salt, the N_b -diastereoisomer of the salt usually obtained on quaternization of antirhine, has been isolated⁷² from *Hunteria eburnea*, together with dihydroantirhine β -metho-salt and pleiocarpamine N_b -metho-salt. During the development of a technique for the separation and identification of micro-quantities of *Rauwolfia* alkaloids the presence of aricine, renoxidine, yohimbine, and serpentine in the roots of *R. caffra* has been established,⁷³ in addition to those alkaloids noted earlier. *R. oreogiton* Mgf., which has previously been confused with *R. volkensii* Stapf., is now regarded as a taxonomically distinct species. Earlier extractions⁷⁴ which resulted in the isolation of four alkaloids, ajmaline, reserpine, reserpinine, and serpentine, were in fact performed on *R. oreogiton*, more refined investigations on which have now yielded in addition ajmalicine, rescinnamine, α -yohimbine and another unidentified yohimbine isomer, and renoxidine.⁷⁵ The same authors have reinvestigated the constituents of the root bark of *R. obscura* and have isolated, among others, deserpidine, methyl deserpidate, and α -yohimbine, and have obtained evidence also for the presence of alstonine.⁷⁶ Ajmalicine and tetrahydroalstonine occur in the roots of *Catharanthus trichophyllus*⁷⁷ and the 11-methoxy-derivative of the latter, reserpinine, occurs in *Vinca major*⁷⁸ and in the aerial parts of *V. libanotica* Zucc., in which it is found in

⁷² R. H. Burnell, A. Chapelle, and M. F. Khalil, *Canad. J. Chem.*, 1974, **52**, 2327.

⁷³ M. S. Habib and W. E. Court, *Planta Med.*, 1974, **25**, 331.

⁷⁴ W. E. Court, *Canad. J. Pharm. Sci.*, 1968, **3**, 70.

⁷⁵ P. Timmins and W. E. Court, *Planta Med.*, 1974, **26**, 170 (*Chem. Abs.*, 1975, **82**, 1939).

⁷⁶ P. Timmins and W. E. Court, *Phytochemistry*, 1974, **13**, 1997.

⁷⁷ A. B. Segelman and N. R. Farnsworth, *J. Pharm. Sci.*, 1974, **63**, 1419.

⁷⁸ A. Banerji and M. Chakrabarty, *Phytochemistry*, 1974, **13**, 2309.

association with rauniticine and 14 other alkaloids.⁷⁹ The bark of *Ochrosia nakaiana*, collected from the Bonin Islands of Japan, contains eight alkaloids, among which are reserpiline, serpentine, dimethoxypicrapphylline, and a new quaternary base, 10-methoxycorynantheol β -metho-salt (51), isolated as its perchlorate.^{32b} The stem bark, fruits, and leaves of *Alstonia venenata* having been studied previously, attention has now been directed towards the roots, which have so far yielded

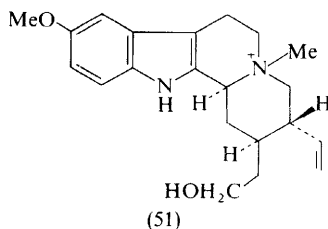

reserpine, venenatine, alstovenine, and 3-dehydroalstovenine chloride.⁸⁰ *Cabucala fasciculata* Pichon is one of several Malagasy plants which have recently been thoroughly investigated by French chemists.^{81a} 14 Alkaloids have so far been isolated, including carpanaubine, 10,11-dimethoxyisomitraphylline, rauvoxinine, cabulatine (reserpiline),^{81b} cabucine (10-methoxyajmalicine), caboxine-A, isocaboxine-A, isocaboxine-B, an unidentified monomethoxyoxindole derivative, and three other alkaloids of unknown structure, cabucinine, caberine, and cabucraline.^{81a} The leaves and stem bark of a related species, *C. erythrocarpa* (Vatke) comb. nov. Mgf. var. *erythrocarpa*, have so far yielded 15 alkaloids; these include aricine, cabucine, cabucinine, cabucraline, caberine, and its demethyl derivative, caberoline.^{81c}

Cephalanthus occidentalis L. (fam. Rubiaceae), a plant said to be responsible for fatally poisoning cattle in the U.S.A., contains six alkaloids in its stems and leaves; these are dihydrocorynantheine and hirsutine, rhynchophylline, isorhynchophylline, rhynchophylline *N*-oxide, and *anti*-isorhynchophylline *N*-oxide.^{82a} The alkaloid content of *Uncaria guaianensis* and *U. tomentosa* is broadly very similar. Both plants contain rhynchophylline, isorhynchophylline, and their *N*-oxides, together with mitraphylline, dihydrocorynantheine, hirsutine, and hirsuteine; in addition *U. tomentosa* contains isomitraphylline and its *N*-oxide, dihydrocorynantheine *N*-oxide, and hirsutine *N*-oxide.^{82b} The two rhynchophylline isomers were also found in the flowers. In an attempt to sort out the confusion that exists concerning the constituents of *Uncaria gambir*, a species which is not easily distinguished from some other species growing in the same area, all 34 Asian *Uncaria* species have been screened for alkaloids.⁸³ Gambirine (9-hydroxydihydrocorynantheine) was found only in *U. callophylla* Bl. ex Korth. and the roxburghines only in *U. elliptica* R. Br. ex

⁷⁹ G. H. Aynilian, N. R. Farnsworth, and J. Trojánec, *Lloydia*, 1974, **37**, 299.

⁸⁰ S. C. Dutta and A. B. Ray, *Indian J. Chem.*, 1975, **13**, 98.

⁸¹ (a) F. Titeux, M. Mansour, M. M. Debray, L. Le Men-Olivier, and J. Le Men, *Phytochemistry*, 1974, **13**, 1620; (b) F. Titeux, L. Le Men-Olivier, and J. Le Men, *Phytochemistry*, 1975, **14**, 565; (c) L. Douzoua, M. Mansour, M. M. Debray, L. Le Men-Olivier, and J. Le Men, *Phytochemistry*, 1974, **13**, 1994.

⁸² (a) J. D. Phillipson and S. R. Hemingway, *Phytochemistry*, 1974, **13**, 2621; (b) S. R. Hemingway and J. D. Phillipson, *J. Pharm. Pharmacol.*, 1974, **26** (Suppl.), 113P.

⁸³ J. D. Phillipson and S. R. Hemingway, *J. Pharm. Pharmacol.*, 1973, **25** (Suppl.), 143P.

G. Don.; these alkaloids have previously been reported to occur in *U. gambir* of doubtful authenticity. The results of the present study are consistent with the report that the material from which the roxburghines were isolated consisted of leaves from four distinct species, including *U. gambir*, *U. ferrea* (Bl.) DC., and *U. elliptica* (syn. *U. dasyoneura* Korth.). The chromatographic and spectroscopic methods used in this extensive screening programme, and the behaviour of over 60 indole alkaloids found in the *Uncaria* genus on which this identification is based, have been thoroughly discussed.⁸⁴

Vinca erecta contains vineridine *N*-oxide and two stereoisomers of majdine, which are all methoxy-substituted oxindole analogues of heteroyohimbine alkaloids.⁸⁵

The alkaloids of *Mitragyna* species continue to receive considerable attention and are the subject of three recent reviews,⁸⁶ and some *in vivo* studies on the interconversion of alkaloids in *M. parvifolia*.⁸⁷ The alkaloidal pattern throughout the year in one Burmese specimen of *M. rotundifolia* has been examined.⁸⁸ In addition to rhynchophylline, isorhynchophylline, and isorhynchophylline *N*-oxide, previously observed in this species, mitraphylline, isomitraphylline, corynoxine, isocorynoxine (52), 3-isoajmalicine, rhynchociline, and ciliaphylline were detected; of these, isocorynoxine has not previously been obtained from natural sources. The rhynchophylline and mitraphylline isomers appeared to predominate throughout the year.⁸⁸ A re-examination⁸⁹ of *M. parvifolia* has disclosed the presence in the leaves of the *N*-oxides of akuammigine, speciophylline, uncarine-F, and dihydrocorynantheol; tertiary alkaloids also identified included those corresponding to the *N*-oxides, together with tetrahydroalstonine, pteropodine, isopteropodine, and corynantheidol.

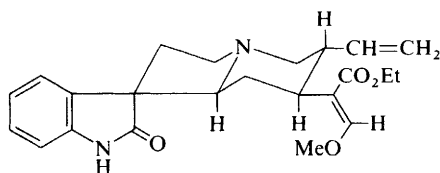

(52)

Angustoline (53), angustine (54), and angustidine (55) are three alkaloids recently isolated from *Strychnos angustiflora* Benth.⁹⁰ These alkaloids have now been shown^{91a,b} to occur widely; angustine, for example, has been identified with Alkaloid Pa 6, isolated⁹² from *Mitragyna javanica*, and with Alkaloid Gu 5, from *M.*

⁸⁴ J. D. Phillipson and S. R. Hemingway, *J. Chromatog.*, 1975, **105**, 163.

⁸⁵ M. M. Khalimirzaev, V. M. Malikov, and S. Yu. Yunusov, *Khim. prirod. Soedinenii*, 1973, 806 (*Chem. Abs.*, 1974, **81**, 166 399).

⁸⁶ E. J. Shellard, *Anales de Quim.*, 1972, **68**, 937; *Plant. Med. Phytother.*, 1973, **7**, 179; *Bulletin on Narcotics*, 1974, **26**, 41.

⁸⁷ P. J. Houghton and E. J. Shellard, *J. Pharm. Pharmacol.*, 1973, **25** (Suppl.), 113P; E. J. Shellard and P. J. Houghton, *Planta Med.*, 1974, **25**, 80.

⁸⁸ P. J. Houghton and E. J. Shellard, *Planta Med.*, 1974, **26**, 104.

⁸⁹ E. J. Shellard and P. J. Houghton, *Planta Med.*, 1974, **25**, 172.

⁹⁰ T. Y. Au, H. T. Cheung, and S. Sternhell, *J.C.S. Perkin I*, 1973, 13.

⁹¹ (a) J. D. Phillipson, S. R. Hemingway, N. G. Bisset, P. J. Houghton, and E. J. Shellard, *Phytochemistry*, 1974, **13**, 973; (b) F. Hotellier, P. Delaveau, and J. L. Pousset, *Phytochemistry*, 1975, **14**, 1407.

⁹² E. J. Shellard, A. H. Beckett, P. Tantivatana, J. D. Phillipson, and C. M. Lee, *Planta Med.*, 1967, **15**, 245.

parvifolia.⁹³ It has also been obtained^{91a} from the leaves of *Nauclea coadunata* Roxb. ex J. E. Smith [*Sarcocephalus coadunata* (Roxb. ex J. E. Smith) Druce], *Uncaria rhynchophylla* and *U. homomalla* Miq., from the flowers of *U. bernaysii*, F.v.M., from the leaves, stems, and flowers of *U. guaianensis* (Aubl.) Gmel., from *Strychnos camptoneura*,^{91a} and from the root bark of *Nauclea latifolia* Sm.^{91b} Angustoline, and very probably (t.l.c. evidence) angustidine also, occur in *U. rhynchophylla* and *U. homomalla*;^{91a} and angustoline occurs in *N. latifolia*.^{91b} Preliminary t.l.c. evidence was also obtained for the presence of angustine-type alkaloids in a number of other African and Asian *Strychnos* species.^{91a}

Angustine and angustoline are accompanied in *N. latifolia*^{91b} by two closely related alkaloids, namely, nauclefine (56), the parent compound of the series, and nauclefine (57), which is very probably the methyl ketone corresponding to angustoline. Reduction (NaBH_4) of nauclefine gave a product very similar to angustoline, but the identity of the two was not rigorously established, owing to lack of material.^{91b}

The structure of angustoline has been confirmed by a brief synthesis (Scheme 11),⁹⁴ in which the crucial stage involved the (non-regiospecific) photochemical dehydrogenative cyclization of the amide (58). Nauclefine was similarly synthesized

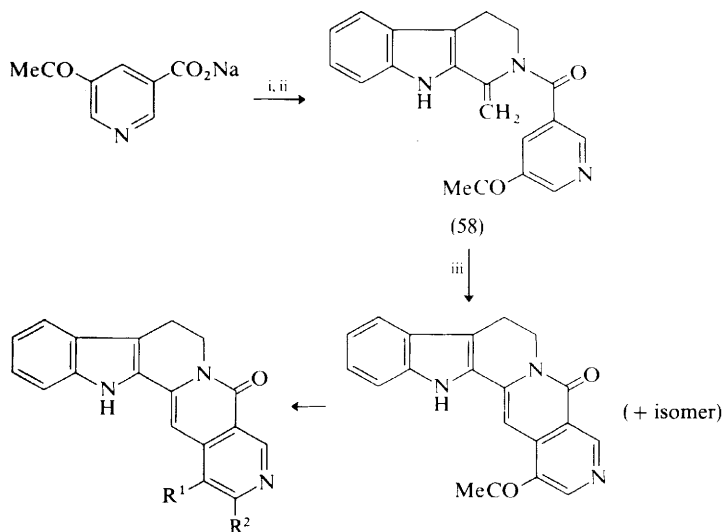

- Angustoline (53) $\text{R}^1 = \text{CHOHMe}$, $\text{R}^2 = \text{H}$
 Angustine (54) $\text{R}^1 = \text{CH}=\text{CH}_2$, $\text{R}^2 = \text{H}$
 Angustidine (55) $\text{R}^1 = \text{H}$, $\text{R}^2 = \text{Me}$
 Nauclefine (56) $\text{R}^1 = \text{R}^2 = \text{H}$
 Nauclefine (57) $\text{R}^1 = \text{COMe}$, $\text{R}^2 = \text{H}$

Reagents: i, $(\text{COCl})_2$; ii, Harmalan; iii, *h\nu*, MeOH, r.t.

Scheme 11

⁹³ E. J. Shellard, J. D. Phillipson, and D. Gupta, *Planta Med.*, 1969, 17, 51.

⁹⁴ I. Ninomiya and T. Naito, *Heterocycles*, 1974, 2, 607.

by reaction of harmalan with nicotinic acid chloride, but in this case the photochemical stage was not necessary, as nauclefine was obtained directly.^{91b} It is unfortunate that the name angustine has also been given⁹⁵ to an alkaloid of *Amsonia angustifolia* subsequently identified as eburnamonine; its congener, angusteine, would appear, from the structure tentatively proposed, to be a stereoisomer of geissoschizine or demethylcorynantheine.

The search for indole alkaloids has resulted in the isolation of yet more alkaloids simply derived in principle from vincoside. *Pauridiantha lyalli*, for example, contains pauridianthol, lyaline, and lyadine, in addition to harman and the simple pyridine ester (59).^{31a} The mass spectrum of lyaline discloses a fragmentation with hydrogen transfer, to give an important peak at m/e 182, corresponding to harman. The other part of the molecule must then resemble the pyridine ester (59), although the alkaloid does not contain a fully aromatic pyridine ring. The n.m.r. data are consistent with the presence in lyaline of a 1,4-dihydropyridine ring, and the complete structure of lyaline is (60).⁹⁶ Lyadine is also a harman derivative, and

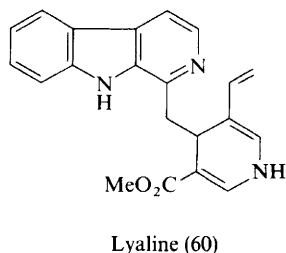
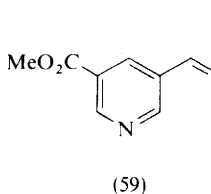

contains a hydroxy-group; since its mass and n.m.r. spectra are completely in accord with a lyaline structure in which the vinyl group is replaced by a hydroxyethyl group, the structure proposed for lyadine is (61).

Photochemical oxidation of lyadine occurs readily (in contrast to lyaline) and affords a product (62) containing a conjugated carbonyl group, whose structure is closely related to that of pauridianthol (63).

Lyaline represents a new structural type which may well be formed by amination of the aglycone derived from vincoside; in which case it is conceivable that it could readily be synthesized *in vitro*.

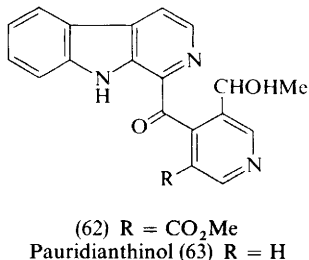
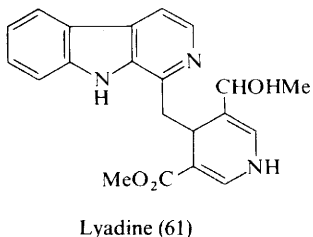

⁹⁵ A. Kocsis, K. Bőjthe-Horváth, I. Mathé, J. Tamás, and O. Clauder, *Acta Pharm. Hung.*, 1974, **44**, 70 (*Chem. Abs.*, 1974, **81**, 120 843).

⁹⁶ J. Levesque, J. L. Pousset, A. Cavé, and A. Cavé, *Compt. rend.*, 1974, **278**, C, 959.

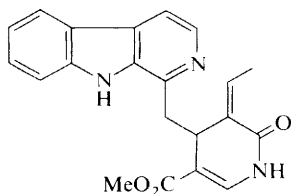

Lyalidine (64)

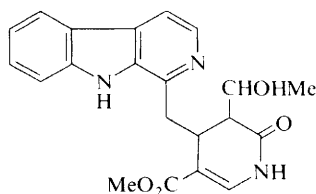

Hydroxylyalidine (65)

The isolation of lyaline and lyadine subsequently prompted a search for minor alkaloids of the same plant, which resulted in the isolation⁹⁷ of lyalidine (64) and hydroxylyalidine (65). The structures followed from their mass and n.m.r. (240 MHz) spectra and the conversion of hydroxylyalidine into lyalidine by treatment with sulphuric acid.

An even more interesting constituent⁹⁸ of this plant is lyaloside (66), a β -glucoside derived from vincoside by aromatization of ring C, but with inversion at C-20. The n.m.r. coupling constants ($J_{15,20} = 3.5$ Hz, $J_{20,21} = 5$ Hz) argue in favour of three equatorial protons in ring E, and thus all three bulky substituents must be axially disposed. Epimerization of C-20 is presumably a consequence of the effective release of the C-21 aldehyde function during the biosynthesis. A very closely related glucoside, palinine [(67), stereochemistry unspecified], has been isolated, together with a dimeric alkaloid, palidimine, which probably contains palinine as one component, from *Palicourea alpina*, a plant reported to exhibit anti-tumour activity.^{32a}

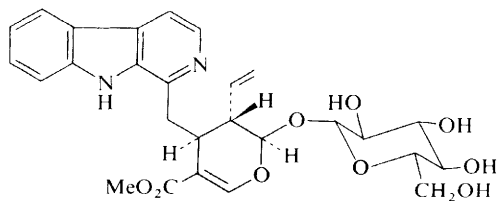

Lyaloside (66)

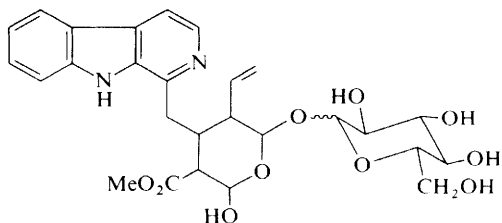

Palinine (67)

Yet another new structural type derived from vincoside is represented by akagerine (68), a constituent of the roots of *Strychnos usambarensis*, the source of an arrow poison in Central Africa.⁹⁹ The structure and relative configuration of

⁹⁷ J. Levesque, J. L. Pousset, and A. Cavé, *Compt. rend.*, 1974, **279**, C, 1053.

⁹⁸ J. Levesque, J. L. Pousset, and A. Cavé, *Compt. rend.*, 1975, **280**, C, 593.

⁹⁹ L. Angenot, O. Dideberg, and L. Dupont, *Tetrahedron Letters*, 1975, 1357.

akagerine were determined by the X-ray method, but it seems more than likely that (68) also represents its absolute configuration (*cf.* configuration at C-15).

An unusual variant in this group of alkaloids is afforded by vinoxine (69),^{100a} an alkaloid of *Vinca minor* first isolated^{100b} in 1967. The structure (69) may very simply be imagined to arise by fission of the C-6—C-7 bond in pleiocarpamine or 16-epipleiocarpamine.

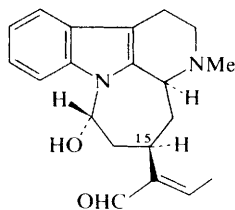

Akagerine (68)

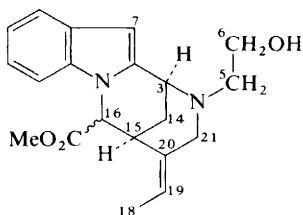

Vinoxine (69)

Macrolidine (70), from the heartwood of *Adina rubescens*, is a new glycosidic indole alkaloid in which the terminal primary alcohol function in a 5-carboxy-isovincoside derivative has formed a novel macrocyclic lactone ring with the retained tryptophan carboxy-group.¹⁰¹ The structure was deduced from the spectra of macrolidine and its tetra-acyl derivatives and confirmed by reaction of macrolidine tetra-acetate with methanolic sodium methoxide followed by re-acetylation, which gave the known methyl 3 α ,5 α -tetrahydrodesoxycordifoline penta-acetate (71).

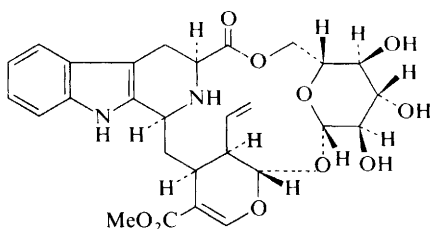

Macrolidine (70)

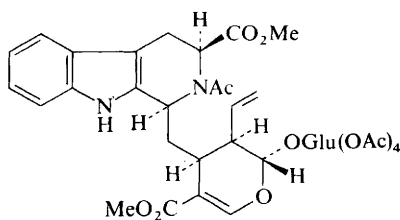

(71)

Another novel structure is provided by isodihydrocadambine (72), from *Anthocephalus cadamba*;¹⁰² this alkaloid contains an N-4—C-19 bond, which can readily be conceived as originating *via* an 18,19-epoxystrictosidine (73). The only other example of an N-4—C-19 bond known to date is perakine.

Another member of the growing group of biosynthetically advanced alkaloids which still retain the tryptophan carboxyl group is provided by 5 β -carboxycorynanthine (74), a constituent of *Adina rubescens*.¹⁰³ The stereochemistry

¹⁰⁰ (a) Z. Votický, E. Grossmann, J. Tomko, G. Massiot, A. Ahond, and P. Potier, *Tetrahedron Letters*, 1974, 3923; (b) J. Mokřý, I. Kompiš, and G. Spiteller, *Coll. Czech. Chem. Comm.*, 1967, **32**, 2523.

¹⁰¹ R. T. Brown and A. A. Charalambides, *J.C.S. Chem. Comm.*, 1974, 553.

¹⁰² R. T. Brown, S. B. Fraser, and J. Banerji, *Tetrahedron Letters*, 1974, 3335.

¹⁰³ R. T. Brown and A. A. Charalambides, *Tetrahedron Letters*, 1974, 3429.

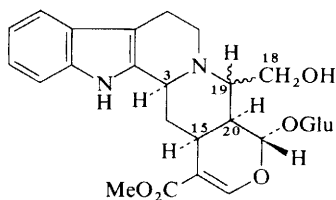

Isodihydrocadambine (72)

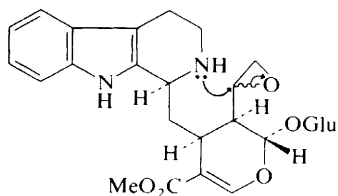

(73)

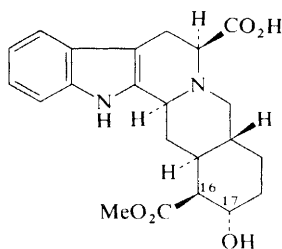

5-β-Carboxycorynanthine (74)

of the C/D and D/E ring junctions was deduced from its spectroscopic properties (c.d., i.r., n.m.r.), and the configuration at C-5 from its presumed derivation from L-tryptophan. The configurations at C-16 and C-17 are based on the analogous chemical behaviour of (74) and corynanthine. Thus, acetylation of (74) by means of Ac_2O -pyridine gives two monoacetates (partial epimerization of C-16), which on methanolysis (NaOMe) afford an isomer of (74) (complete epimerization of C-16 and release of OH). Oxidation of (74) to the corresponding keto-ester followed by reduction (NaBH_4) yields another isomer of (74), presumably 5β-carboxy-β-yohimbine, in which both C-16 and C-17 substituents are equatorial.

Ochromianine, a constituent of the bark of *Ochrosia miana*, exhibits a mass spectrum virtually identical with that of the isomeric 10-methoxydihydrocorynantheol.¹⁰⁴ The spectroscopic properties of ochromianine suggest that it is a 6-methoxyindole derivative, and that it contains a 3α,15α-hydrogen configuration, but the configuration at C-20 cannot be regarded as established. The related oxindole A, ochromianoxine (75), accompanies ochromianine in the plant.

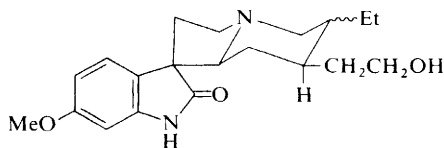

Ochromianoxine (75)

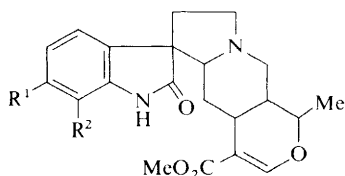
(76) a; $\text{R}^1 = \text{OMe}$, $\text{R}^2 = \text{OH}$
b; $\text{R}^1 = \text{OH}$, $\text{R}^2 = \text{OMe}$

¹⁰⁴ N. Preaux, M. Koch, and M. Plat, *Phytochemistry*, 1974, **13**, 2607.

Vinerinine, from *Vinca erecta*, is a new alkaloid of the oxindole series for which structure [(76, a or b) stereochemistry unspecified] is proposed.¹⁰⁵ Vinerine and vineridine, from the same plant, are reported¹⁰⁶ to belong to the *pseudo* series, and to be the 7*R* (77) and 7*S* (78) isomers, respectively. Reaction of vinerine with acetic

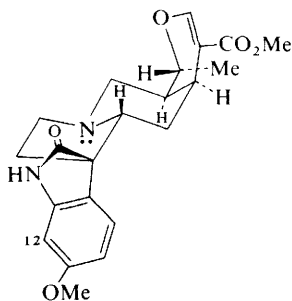

Isocaboxine B (77)
(Vinerine?)

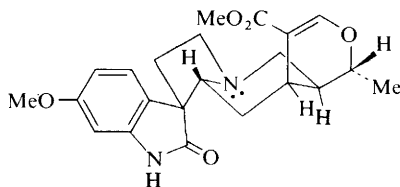

Isocaboxine A (78)
(Vineridine?)

anhydride is said to result in formation of *N*-acetylvinerine (7*S*, 3*S*) with inversion at both C-3 and C-7. This report, however, conflicts with one^{81b} in which the structures of caboxine-A, isocaboxine-A, and isocaboxine-B are elucidated. These three isomers can be equilibrated with each other, *e.g.* by heating in acetic acid or pyridine, and are clearly derived from the *same* 11-methoxyheteroyohimbine alkaloid; they thus possess the same configurations at C-15, C-19, and C-20. N.m.r. data suggest that caboxine A (79) belongs to the *allo* series, and that isocaboxine A (78) and

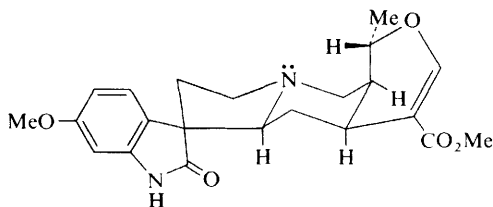

Caboxine A (79)

isocaboxine B (77) belong to the *epiallo* series; all three alkaloids bear an α -methyl group at C-19, and should thus be directly related to reserpinine (cabulatine), found in the same plant. This was proved by conversion of reserpinine *in vitro* into caboxine-A; the reverse change was also accomplished. Isocaboxine A (7*S*) is thus assigned the same stereochemistry as vineridine, and isocaboxine B the same stereochemistry as vinerine, yet it is specifically stated^{81b} that none of the *Cabucula* alkaloids is identical with vineridine. This contradiction has yet to be resolved, but it is noteworthy that comparison of the limited n.m.r. data available supports the identity of the two alkaloids in each stereochemical pair, the only significant

¹⁰⁵ M. M. Khalmirzaev, V. M. Malikov, and S. Yu. Yunusov, *Khim. prirod. Soedinenii*, 1974, 411 (*Chem. Abs.*, 1974, **81**, 152 474).

¹⁰⁶ M. R. Yagudaev, V. M. Malikov, and S. Yu. Yunusov, *Khim. prirod. Soedinenii*, 1974, 493 (*Chem. Abs.*, 1975, **82**, 16 977).

difference recorded in the chemical shifts being an unaccountably low-field signal attributed to the proton at C-12 in vinerine and vineridine.¹⁰⁶

Three new, interconvertible isomers of speciofoline have been isolated from leaves of *Mitragyna speciosa*,¹⁰⁷ and the stereochemistry of all four bases has been elucidated. They constitute the four *allo-epiallo* isomers of the oxindole analogue of 9-hydroxycorynantheidine; mitrafoline is the *allo-A* isomer (80), isomitrafoline is *allo-B* (81), isospeciofoline is *epiallo-A* (82), and speciofoline is *epiallo-B* (83). New studies of the isomerization of isotrotundifoline [*normal B* isomer of (83)] have revealed the formation of a transient product identified as 3-epi-isotrotundifoline [*pseudo-B* isomer of (83)]; there is, however, no evidence to suggest that it is a

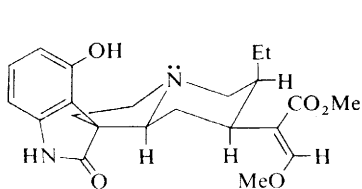

Mitrafoline (80)

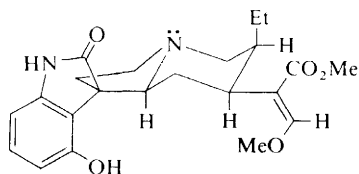

Isomitrafoline (81)

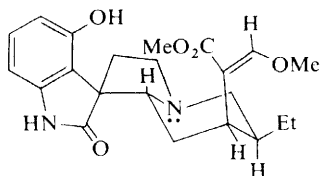

Isospeciofoline (82)

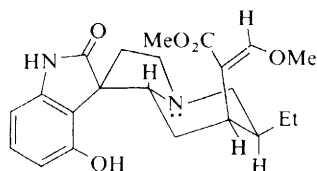

Speciofoline (83)

natural product. A closer examination of samples of rotundifoline and isotrotundifoline previously isolated from *M. parvifolia* resulted in the isolation¹⁰⁷ of the vinyl analogues, rotundifoleine (84) and isotrotundifoleine (85).

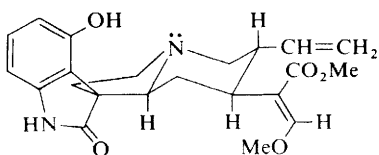

Rotundifoleine (84)

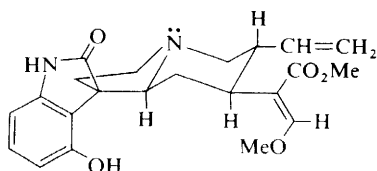

Isotrotundifoleine (85)

The microbiological oxidation of mitragynine by a *Helminthosporium* fungus affords two major metabolites, identified¹⁰⁸ as mitragynine pseudoindoxyl and hydroxymitragynine pseudoindoxyl.

¹⁰⁷ S. R. Hemingway, P. J. Houghton, J. D. Phillipson, and E. J. Shellard, *Phytochemistry*, 1975, **14**, 557.

¹⁰⁸ J. E. Zarembo, B. Douglas, J. Valenta, and J. A. Weisbach, *J. Pharm. Sci.*, 1974, **63**, 1407.

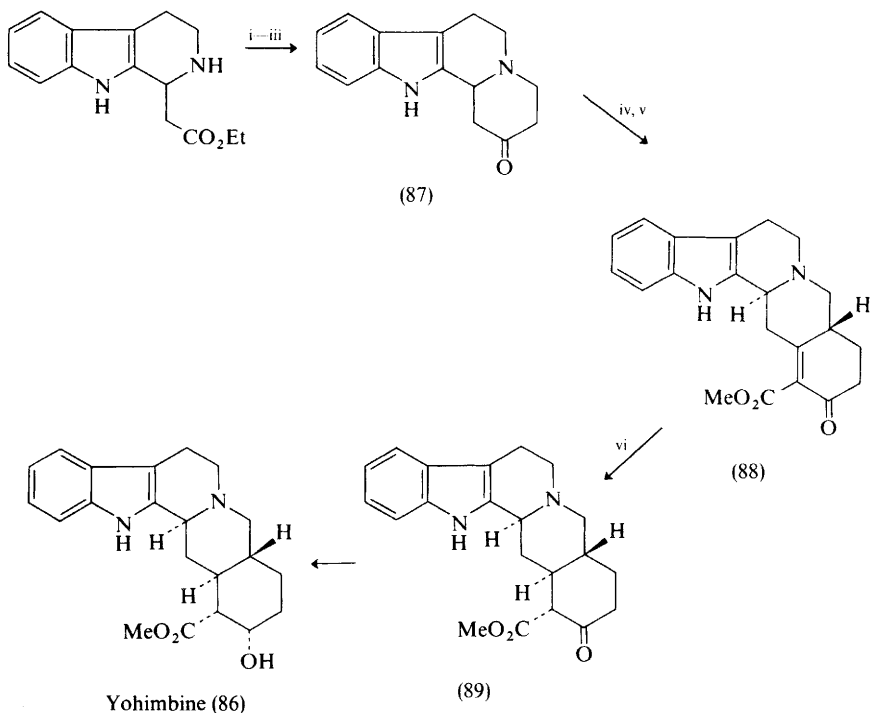

Reagents: i, $\text{CH}_2=\text{CH}\cdot\text{CN}$; ii, NaH , C_6H_6 , 80°C ; iii, $10\% \text{H}_2\text{SO}_4$, 100°C ; iv, pyrrolidine enamine formation; v, $\text{CH}_2=\text{CH}\cdot\text{COCH}_2\text{CO}_2\text{Me}-\text{C}_6\text{H}_6$, 80°C ; vi, H_2 -Pd/C-MeOH.

Scheme 12

The most recent synthesis¹⁰⁹ of yohimbine (86) (Scheme 12) involves as the most critical stages the Michael addition-cyclization of the pyrrolidine enamine of the ketone (87) with methyl 3-oxopent-4-enoate, and the stereoselective hydrogenation of the product (88) to give yohimbine (86), which had previously been converted into yohimbine by other workers.

The synthesis of corynantheine and heteroyohimbine alkaloids along biogenetic lines continues to be widely investigated. Much of the fascinating work in this area comes from Brown's laboratory, and deserves a fuller discussion than is possible here. The synthesis of the *Corynanthe* group may be exemplified by the conversion of *N*₆-benzylidihydrovincoside (90) into hirsutine (91) and dihydrocorynantheine (Scheme 13).¹¹⁰ This sequence indicates that C-21 retains its stereochemical integrity in the conversion into dihydrocorynantheine, but suffers an inversion in the formation of dihydroisositsirikine. Since 20 α -dihydromancunine appears already to have C-20 inverted this must occur during the cyclization of *N*₆ on to C-21; this is plausible, since the initially formed 20 β -dihydromancunine, a carbinolamine ether, has an axial ethyl group which can be changed to the more stable 20 α -isomer *via* a

¹⁰⁹ T. Kametani, M. Kajiwara, T. Takahashi, and K. Fukumoto, *Heterocycles*, 1975, **3**, 179.

¹¹⁰ R. T. Brown, C. L. Chapple, and A. A. Charalambides, *J.C.S. Chem. Comm.*, 1974, 756.

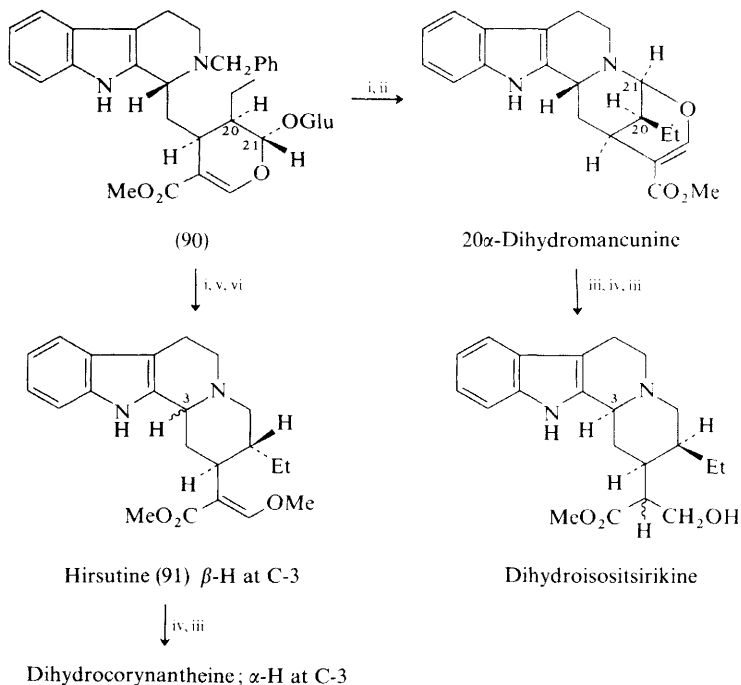

Reagents: i, β -Glucosidase; ii, H_2 -Pd/C-MeOH-AcOH; iii, $NaBH_4$ -MeOH; iv, $Pb(OAc)_4$; v, CH_2N_2 ; vi, H_2 -catalyst.

Scheme 13

ring-opened hydroxy-enamine.¹¹⁰ Another synthetic sequence (Scheme 14),¹¹¹ on N_b -benzylvincoside (92), yields 3-iso-19-epiajmalicine and 19-epiajmalicine; neither of these occurs naturally, but both were identified by comparison with synthetic material, and by transformation of either epimer into a mixture of naturally-occurring formosanine and isoformosanine. An interesting and possibly important biogenetic point to emerge from this study is the fact that the stereochemistry generated at C-19 and C-20 is apparently closely dependent on that at the existing asymmetric centres C-3 and C-15.

This synthesis deviated from the presumed biogenetic route intended because of the cyclization of N_a on to C-21, with formation of (93). Methylation of the indolic nitrogen forced the product (95) formed by removal of the sugar unit from N_b -benzyl- N_a -methylvincoside (94) to take a different course, with equally interesting results.¹¹² The product (95) was a rearranged aglycone which on hydrogenolysis afforded N_a -methyltetrahydroalstonine (96), 3β -H, 20β -H- N_a -methyl-dihydrogeissoschizine (97), and a smaller amount of the 3α -epimer (98). Epimerization of the C-3 hydrogen has thus occurred in the formation of two of these products, and

¹¹¹ R. T. Brown and C. L. Chapple, *J.C.S. Chem. Comm.*, 1974, 740.

¹¹² R. T. Brown, C. L. Chapple, R. Platt, and H. Spencer, *J.C.S. Chem. Comm.*, 1974, 929.

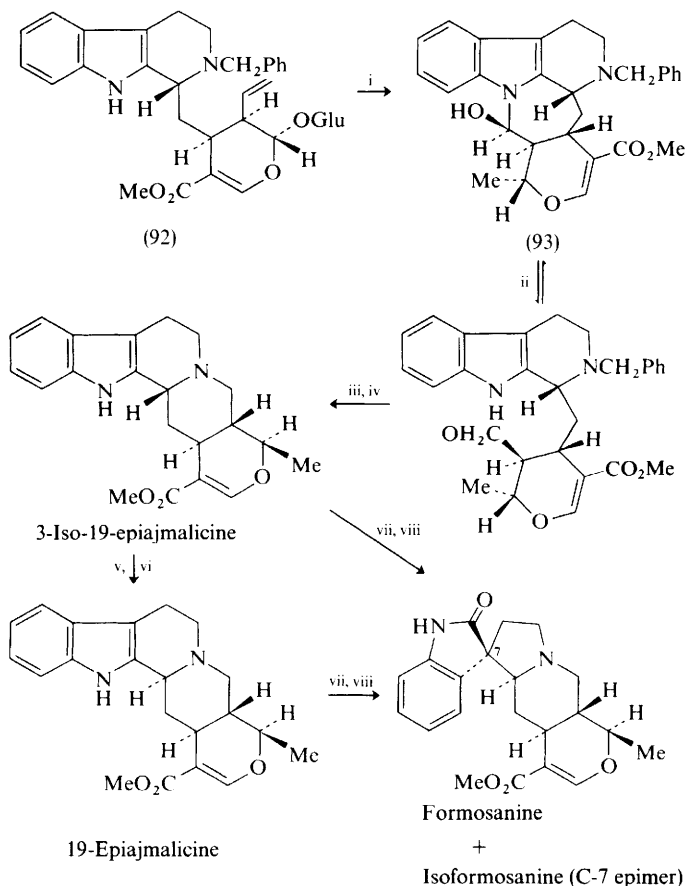

Reagents: i, Carefully controlled removal of sugar; ii, $\text{NaBH}_4\text{-Me}_2\text{CHOH}$; iii, MeSO_2Cl ; iv, $\text{H}_2\text{-Pd/C-H}^+$; v, Pb(OAc)_4 ; vi, NaBH_4 ; vii, Bu^tOCl ; viii, $\text{H}_3\text{O}^+\text{-MeOH}$.

Scheme 14

the equilibria shown in Scheme 15, starting from the initially formed hydrogenolysis product [(99), $\beta\text{-H}$ at C-3], explain how this is readily possible. Biogenetically the unmethylated analogue (101) of the intermediate (100) could well be formed from mancumine (102) by opening of the carbinolamine ether bridge; from (101) all the *Corynanthe*-heteroyohimbine alkaloids can be derived by simple processes of the kind summarized in Scheme 15.¹¹²

The initial preparation of dihydromancunine (Scheme 13) used an N_b -blocking group to avoid formation of vallesiachotamine derivatives (*i.e.* cyclization of C-17 onto N_b). Subsequently¹¹³ it was found that a blocking group is unnecessary if more acidic media are used, but the yield is lower owing to denaturing of the enzyme used. In an extension of these studies to the $3\alpha\text{-H}$ series strictosidine, treated with

¹¹³ R. T. Brown, C. L. Chapple, and A. G. Lashford, *J.C.S. Chem. Comm.*, 1975, 295.

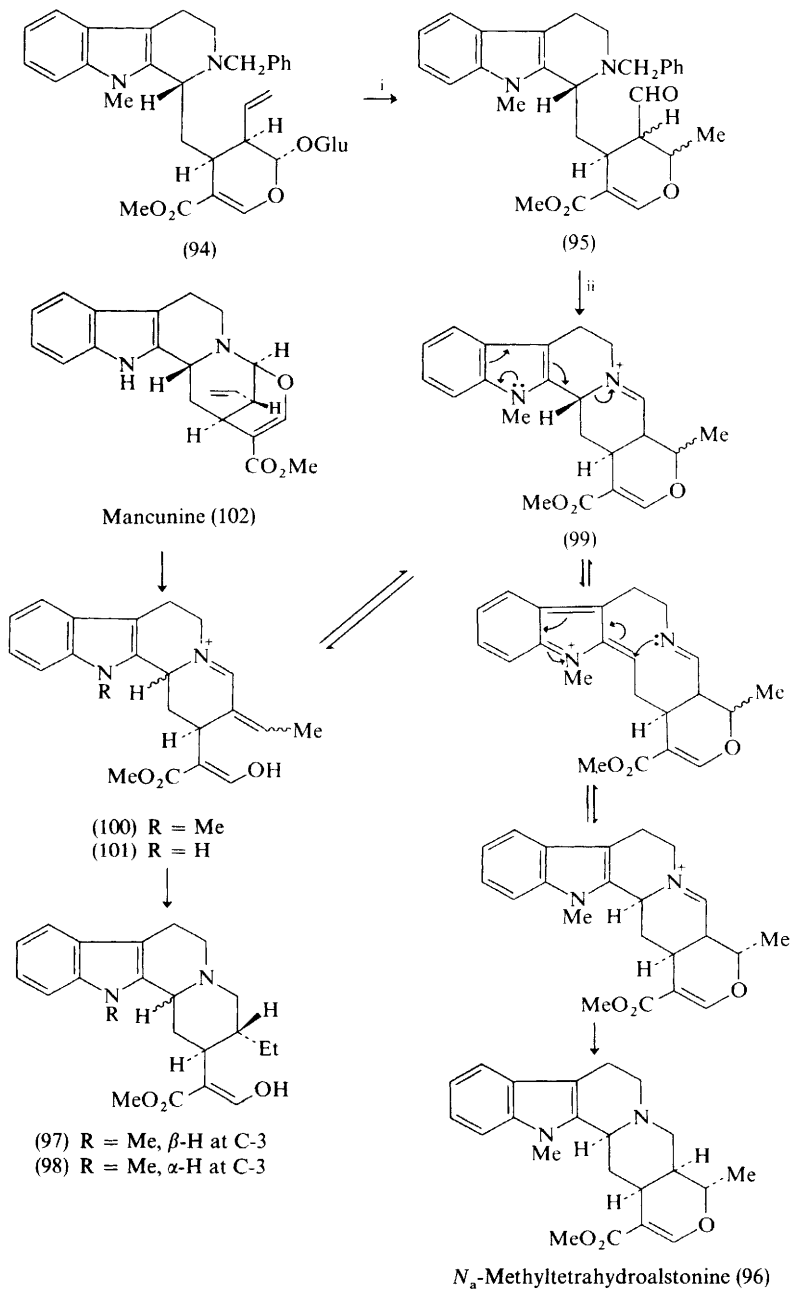

Reagents: i, β -Glucosidase; ii, H_2 -Pd/C, MeOH-AcOH.

Scheme 15

methanolic HCl (Scheme 16) gave a product, nacycline (103), in which C-21 had cyclized on to N_a . Confirmation of this structure was obtained by acid-catalysed conversion of (103) into two epimers (104), epimeric at C-3 with a product obtained

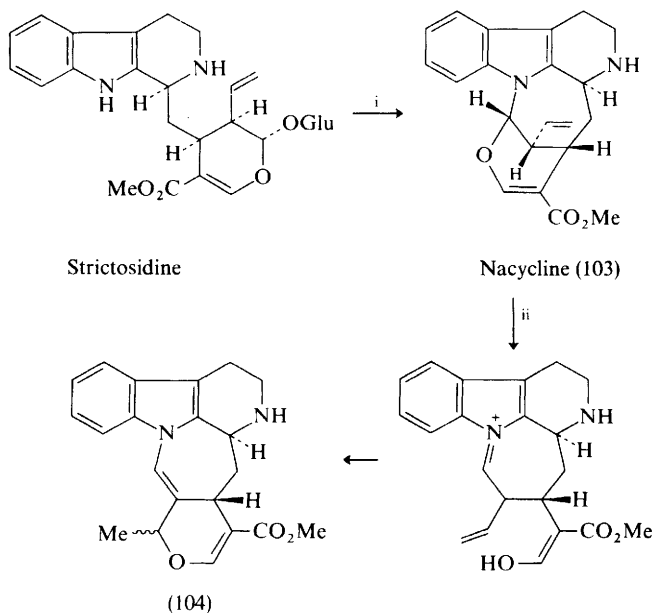

Reagents: i, MeOH-HCl ; ii, $\text{CF}_3\text{CO}_2\text{H}$.

Scheme 16

earlier by acid-catalysed dehydration of (93). It thus appears that in the $3\alpha\text{-H}$ series cyclization will occur onto N_a even though the more reactive N_b is unprotected; presumably because of steric reasons. For the same reasons it appears equally unlikely that in the $3\beta\text{-H}$ series cyclization onto N_a is possible.¹¹³

The first total synthesis¹¹⁴ of geissoschizine (Scheme 17) also embraces the synthesis of geissoschizol and the dimeric alkaloid geissospermine. Geometrical isomerism in the intermediates was avoided by use of the geometrically pure unsaturated ester (105); this also establishes the geometry of the C-19–C-20 double bond in geissoschizine. It is also notable that the intermediate formed in the tetrahydro- β -carboline cyclization stage is predominantly the one with a *trans*-arrangement of hydrogens at C-3 and C-15.

A synthesis¹¹⁵ of oxogambirtannine (Scheme 18) has also been reported.

Finally, the conversion¹¹⁶ of dihydrocorynantheine and hirsutine (91) into 20 α -ethyl-19,20-dihydro-16-epipleiocarpamine (106) and the base (107) constitutes a total synthesis of these compounds (Scheme 19).

¹¹⁴ K. Yamada, K. Aoki, T. Kato, D. Uemura, and E. E. van Tamelen, *J.C.S. Chem. Comm.*, 1974, 908.

¹¹⁵ H. Irie, J. Fukudome, T. Ohmori, and J. Tanaka, *J.C.S. Chem. Comm.*, 1975, 63.

¹¹⁶ S. Sakai and N. Shinma, *Chem and Pharm Bull. (Japan)*, 1974, **22**, 3013.

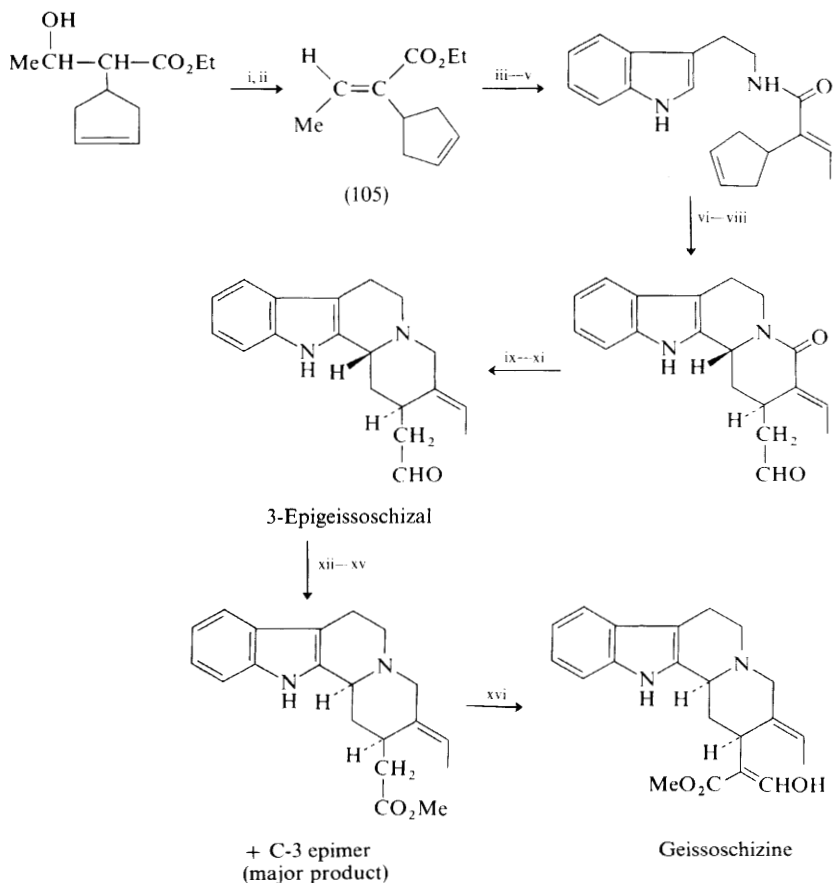

Reagents: i, TsCl-pyridine; ii, Bu^tOK-Bu^tOH, and separation of geometrical isomers: iii, OH⁻;

iv, -OH-DCC-MeCO₂Et; v, tryptamine-THF; vi, OsO₄-THF-pyridine, -70 °C; vii, NaIO₄-H₂O-acetone; viii, acetone-0.05 M HCl, 60 °C, 30 min; ix, ethylene ketal formation; x, AlH₃-THF, 0 °C; xi, 1M HCl, r.t., 20 h; xii, Ag₂O; xiii, MeOH-HCl; xiv, Hg(OAc)₂, THF-AcOH-H₂O; xv, Zn-AcOH; xvi, HCO₂Me-LiNPr₂-THF, -30 °C.

Scheme 17

The n.m.r. spectrum of reserpine in the presence of the europium shift reagent is interpreted¹¹⁷ in terms of a boat-shaped conformation of ring C.

The structures proposed previously for naucleonine and naucleonidine,^{118a} on which doubt has already been cast,^{118b} have now been re-examined.¹¹⁹ The correct

¹¹⁷ K. Jankowski, O. Pelletier, and R. Tower, *Bull. Acad. polon. Sci., Sér. Sci. Chim.*, 1974, **22**, 867.

¹¹⁸ (a) D. G. Murray, A. Szokolcai, and S. McLean, *Canad. J. Chem.*, 1972, **50**, 1486; (b) J. A. Joule, in 'The Alkaloids', ed. J. E. Saxton (Specialist Periodical Reports), The Chemical Society, London, 1974, Vol. 4, p. 293; (c) *ibid.*, p. 309.

structures, (108) and (109), respectively, were deduced from a study of the n.m.r. spectra of model compounds, and confirmed by synthesis (Scheme 20).¹¹⁹ Each alkaloid was obtained as a pair of inseparable diastereoisomers, identical with natural material (except in optical rotation). This diastereoisomerism explains the doubling of n.m.r. resonances in the alkaloids.

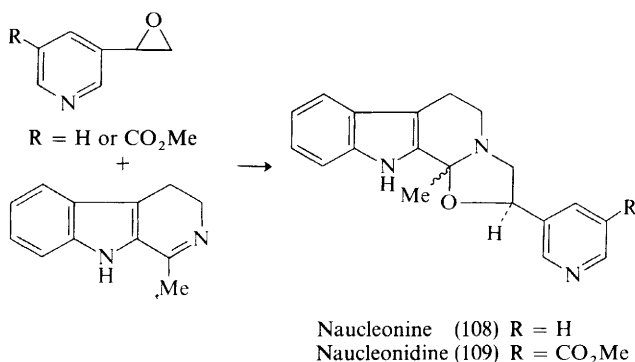

Scheme 20

Sarpagine–Ajmaline–Picaline Group. Brief summaries of the chemistry,^{120a} physico-chemical properties,^{120b} and the pharmacology^{120c} of ajmaline have been published.

Sarpagine has been detected in the root bark of *Rauwolfia caffra*,⁷³ and ajmaline, vomalidine, and a methoxyajmaline have been isolated⁷⁶ from *R. obscura*. Akuammidine (rhazine) occurs in *Amsonia angustifolia*,¹²¹ *Pandaca ochracea* Mgf.,¹²² in the fruits of *Voacanga grandifolia* (Miq.) Rolfe,¹²³ and in *Ochrosia nakaiana*,^{32b} where it accompanies vobasine, among other alkaloids. Other new sources of vobasine include *Peschiera laeta*,⁶⁹ which also contains affinine and tombozine, *Pandaca eusepala* Mgf.,^{124a} and *Gabunia eglandulosa* Stapf., in which it occurs together with perivine and five *Iboga* alkaloids.^{124b} The aerial parts of *Vinca erecta* contain¹²⁵ *O*-benzoyltombozine, and those of *V. major* contain,⁷⁸ among others, majoridine, vincamajoreine, 10-methoxyvellosimine (previously noted), and a new base, lochvinerine (110), the C-17 epimer of lochnerine. Akuammine, quebrachidine, ochropamine, and vellosimine have been isolated^{81c} from *Cabucala erythrocarpa* var. *erythrocarpa*, which also contains cabuamine, a new base in this

¹¹⁹ G. I. Dmitrienko, A. Szokolcai, and S. McLean, *Tetrahedron Letters*, 1974, 2599.

¹²⁰ (a) E. Schlittler, *Arzneimittelforsch.*, 1974, **24**, 873; (b) A. Petter, *ibid.*, p. 874; (c) A. Petter and K. Engelmann, *ibid.*, p. 876.

¹²¹ K. Bőjthe-Korváth, A. Kocsis, I. Mathé, T. Tamás, and O. Clauder, *Acta Pharm. Hung.*, 1974, **44**, 66 (*Chem. Abs.*, 1974, **81**, 136 347).

¹²² J. M. Panas, B. Richard, C. Sigaut, M. M. Debray, L. Le Men-Olivier, and J. Le Men, *Phytochemistry*, 1974, **13**, 1969.

¹²³ P. L. Majumdar and B. N. Dinda, *J. Indian Chem. Soc.*, 1974, **51**, 370.

¹²⁴ (a) F. Quirín, M. M. Debray, C. Sigaut, P. Thepenier, L. Le Men-Olivier, and J. Le Men, *Phytochemistry*, 1975, **14**, 812; (b) V. C. Agwada, Y. Morita, U. Renner, M. Hesse, and H. Schmid, *Helv. Chim. Acta*, 1975, **58**, 1001.

¹²⁵ M. R. Sharipov, M. Khalmirzaev, V. M. Malikov, and S. Yu. Yunusov, *Khim. prirod. Soedinenii*, 1974, 413 (*Chem. Abs.*, 1974, **81**, 152 475).

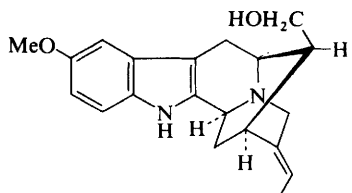

Lochvinerine (110)

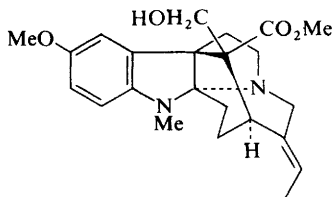

Cabuamine (111)

series, and desformocabuamine. Cabuamine appears to be simply^{126a} *O*-methyl dihydroakuammine (111), and can be prepared by Zn–AcOH reduction of *O*-methylakuammine. Treatment of cabuamine with alkali results in retro-aldol loss of formaldehyde with formation of desformocabuamine (112), identical with vincorine isolated^{126b} in 1962 from *Vinca minor*. It seems almost certain that it is also identical with vincovine,^{126c} to which had been attributed a structure isomeric with (112), with the methoxyl group situated at C-11. *Cabucala fasciculata* contains^{81a} *O*-methylakuammine, and the bark of *Strychnos amazonica* has yielded^{127a} macusine-B. This last alkaloid also occurs^{127b} in the roots of *S. usambarensis* together with two other (new) quaternary alkaloids, *O*-methylmacusine-B and *O*-methyl dihydromacusine-B.

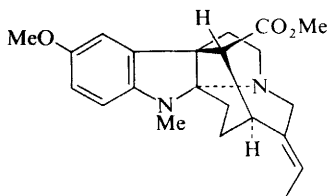

Vincorine (112)

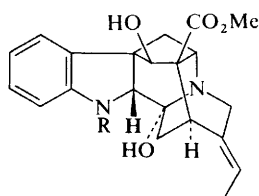
Herbamine (113) R = Me
Herbadine (114) R = H

The aerial parts of Lebanese *Vinca libanotica* Zucc. appear to contain 16 alkaloids, of which 12 have so far been isolated;⁷⁹ these include, in the present group, vincamajine (the major alkaloid), picrinine, quebrachidine, vincamidine, vincamidine hydrate, herbamine, and herbadine. The structures earlier proposed¹²⁸ for herbamine and herbadine have now been shown¹²⁹ to be incorrect, and on the basis of mass spectral and 220 MHz n.m.r. data, have been shown to be (113) and (114) respectively. The n.m.r. spectrum of herbamine is very similar to that of vincamajine except for the non-equivalence of the C-21 protons in herbamine. Inspection of models, confirmed by n.m.r. studies in the ajmaline-2-epiajmaline series, indicates

¹²⁶ (a) M. Mansour, L. Le Men-Olivier, J. Lévy, and J. Le Men, *Phytochemistry*, 1974, **13**, 2861; (b) J. Mokry, L. Dúbravková, and P. Šefčovič, *Experientia*, 1962, **18**, 564; (c) H. Meisel and W. Döpke, *Tetrahedron Letters*, 1971, 1285.

¹²⁷ (a) C. Galeffi, E. M. Delle Monache, and G. B. Marini-Bettòlo, *Ann. Chim. (Italy)*, 1973, **63**, 849; (b) L. Angenot, *Planta Med.*, 1975, **27**, 24.

¹²⁸ V. Y. Vachnadze, V. M. Malikov, K. S. Mudzhiri, and S. Yu. Yunusov, *Khim. prirod. Soedinenii*, 1972, **341** (*Chem. Abs.*, 1972, **77**, 152 416); (b) ref. 118b, p. 299.

¹²⁹ (a) G. H. Aynilian, C. L. Bell, N. R. Farnsworth, and D. J. Abraham, *Lloydia*, 1974, **37**, 589; (b) G. H. Aynilian, C. L. Bell, and N. R. Farnsworth, *J. Pharm. Sci.*, 1975, **64**, 341.

that the equivalence (or otherwise) of the C-21 protons depends on the stereochemistry at C-2, and thus the n.m.r. spectrum affords an easy means of differentiating between the two series. On this basis herbamine (113) belongs to the ajmaline series and since the C-2 proton gives rise to a singlet the remaining hydroxy-group is placed at C-3. This is confirmed by the signal owing to the C-14 α proton, which shows only geminal coupling.^{129a} Similar reasoning, together with a comparison of the mass spectra of herbamine, herbadine, and quebrachidine, led to the establishment of structure (114) for herbadine.^{129b}

Dregamine is the major alkaloid of Malagasy *Pandaca calcarea* (Pichon) Mgf. and also occurs in *P. debrayi*,¹³⁰ *P. caducifolia* Mgf. [in association with desmethoxycarbonylervatamine (115)],¹³¹ and in yet another Malagasy plant, *Muntafara sessilifolia* (Bak.) Pichon, together with tabernaemontanine and 17 other alkaloids.¹³² Tabernaemontanine has also been extracted from a variety of *Tabernaemontana divaricata* R. Br. ex Roem. et Schult., grown in India as an ornamental shrub.¹³³

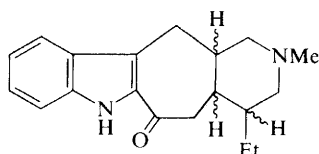

(115)

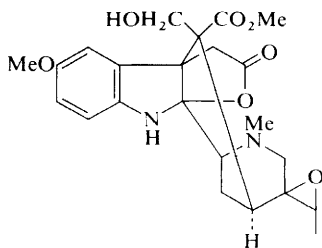

(119)

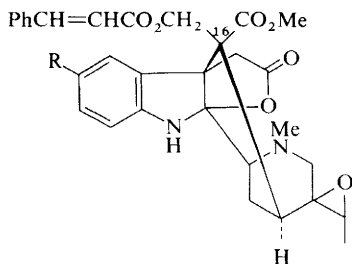

Lanciferine (116) R = H
 10-Methoxylanciferine (117) R = OMe
 10-Hydroxylanciferine (118) R = OH

An *Alstonia* species not previously investigated, *A. lanceolifera* S. Moore, contains¹³⁴ six alkaloids in its aerial parts, including 10-methoxy-*N*-methylakuammidine, which also occurs in its stem bark. The aerial parts also contain three new alkaloids in a less familiar structural vein, lanciferine (116), 10-methoxylanciferine (117), and 10-hydroxylanciferine (118). The major structural features in these alkaloids follow from the removal by methanolysis of the cinnamoyl group to give 10-methoxylanciferol (119), which on more vigorous treatment with

¹³⁰ M. J. Hoizey, M. M. Debray, L. Le Men-Olivier, and J. Le Men, *Phytochemistry*, 1974, **13**, 1995.

¹³¹ M. Zeches, M. M. Debray, G. Ledouble, L. Le Men-Olivier, and J. Le Men, *Phytochemistry*, 1975, **14**, 1122.

¹³² J. M. Panas, B. Richard, C. Potron, R. S. Razafindrambao, M. M. Debray, L. Le Men-Olivier, J. Le Men, A. Husson, and H. P. Husson, *Phytochemistry*, 1975, **14**, 1120.

¹³³ K. Raj, A. Shoeb, R. S. Kapil, and S. P. Popli, *Phytochemistry*, 1974, **13**, 1621.

¹³⁴ G. Lewin, N. Kunesch, and J. Poisson, *Compt. rend.*, 1975, **280**, C, 987.

MeONa loses formaldehyde by reverse aldol reaction. Methylation of (119) with diazomethane yields a methyl ester, with concomitant appearance of an indolenine chromophore. N.m.r. and mass spectral data reveal the presence of the epoxide function, and determine the configuration at C-16. The remainder of the stereochemical details, and the position of the *aryl* methoxy-group, which rests at present solely on u.v. evidence, have yet to be established.¹³⁴

A new alkaloid of *Gelsemium sempervirens* is considered to be 21-oxogelsemine (120).¹³⁵ The structure of this constituent was deduced mainly by mass spectroscopy, but if (120) is correct it is difficult to understand why separation from gelsemine was not easy. Presumably (120) is non-basic!

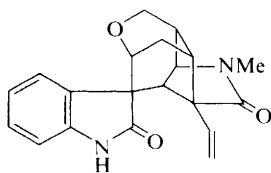

21-Oxogelsemine (120)

Four new bases from *Gardneria multiflora* include three iminoether derivatives and one oxindole.^{136a} Gardfloramine (121) has a structure analogous to that of gardneramine (122) in which two methoxy-groups are replaced by a methylenedioxy-group; a second new base is 18-desmethoxygardneramine (123) in which the 19,20-double bond has the *E*-configuration (in contrast to gardneramine), and a third is 18-desmethoxygardfloramine (124). The fourth base (Alkaloid F),^{136b}

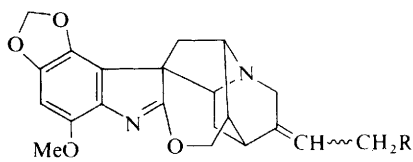

Gardfloramine (121) R = OMe
(124) R = H

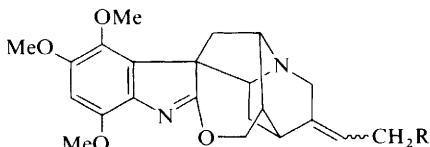

Gardneramine (122) R = OMe, *Z*-isomer
(123) R = H, *E*-isomer

now named chitosenine (125), is an oxindole derivative, whose structure follows from spectroscopic data and from its conversion into a close analogue (126) of gardneramine by treatment of chitosenine monomesylate with sodium methoxide.^{136a}

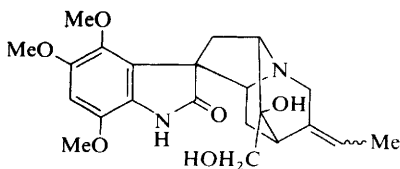

Chitosenine (125)

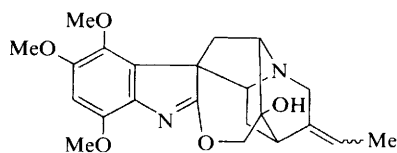

(126)

¹³⁵ A. Nikiforov, J. Latzel, K. Varnuza, and M. Wichtl, *Monatsh.*, 1974, **105**, 1292.

¹³⁶ (a) S. Sakai, N. Aimi, K. Yamaguchi, H. Ohhira, K. Hori, and J. Haginiwa, *Tetrahedron Letters*, 1975, 719; (b) J. Haginiwa, S. Sakai, A. Kubo, K. Takahashi, and M. Taguchi, *Yakugaku Zasshi*, 1970, **90**, 219.

The chiroptical properties of six alkaloids and three ajmaline degradation products in the akuammidine–sarpagine group have been discussed;¹³⁷ all give positive Cotton effects in the 270–300 nm region, and all have the 3S configuration, as had been independently deduced from the chemical evidence.

The conversion of deacetyldeformopicaline into deacetyldeformoakuammiline and of picaline into akuammiline by vigorous reduction with sodium cyanoborohydride¹³⁸ establishes the structure proposed for akuammiline and also the configuration at C-16. Other transformations in this group include the von Braun demethylation of dregamine and tabernaemontanine, which affords^{139a} all four epimers of the dihydroperivine (127) type. Partial racemization of C-16 occurs during the methanolysis of the cyanamide intermediate (128); this is explained by neighbouring-group participation by the nitrile group (Scheme 21).

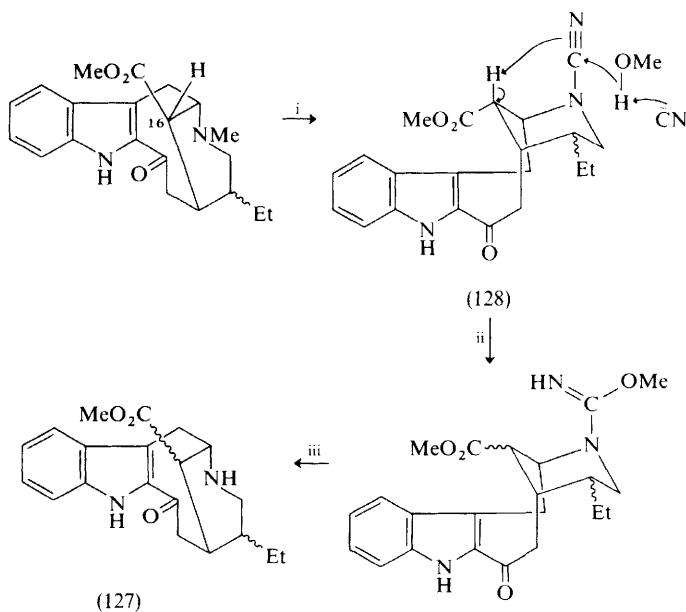

Reagents: i, BrCN; ii, KCN–MeOH; iii, AcOH.

Scheme 21

The total synthesis^{139b} of 16-desmethoxycarbonylvobasine (129) involves as critical stages a neat introduction of an acetic ester residue by Claisen rearrangement of an ortho-ester, and the cyclization of the acid derived from the product by means of polyphosphoric acid (Scheme 22). The synthesis^{139c} of 15,20-dehydroervatamine (130) involves the gramine alkylation of a 4-piperidone ester to give the amino-ketone (131) which on acetylation, ketol cyclization, and dehydration afforded (130) (Scheme 23).

¹³⁷ K. Bláha, Z. Koblicova, and J. Trojánek, *Coll. Czech. Chem. Comm.*, 1974, **39**, 3168.

¹³⁸ M. D. de Mairville, L. Le Men-Olivier, J. Lévy, and J. Le Men, *Compt. rend.*, 1975, **280**, C, 131.

¹³⁹ (a) P. Mangeney, Y. Langlois, and P. Potier, *Tetrahedron*, 1975, **31**, 429; (b) Y. Langlois and P. Potier, *ibid.*, p. 419; (c) Y. Langlois and P. Potier, *ibid.*, p. 423.

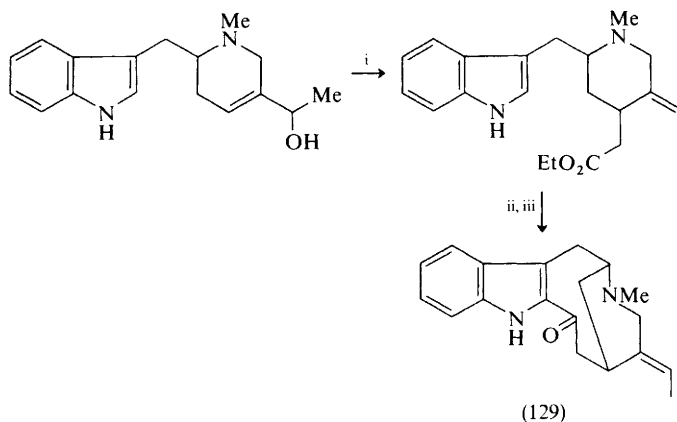

Reagents: i, $\text{MeC}(\text{OEt})_3$, $\text{C}_3\text{H}_7\text{CO}_2\text{H}$, diglyme, N_2 ; ii, $\text{Ba}(\text{OH})_2$, dioxan; iii, PPA.

Scheme 22

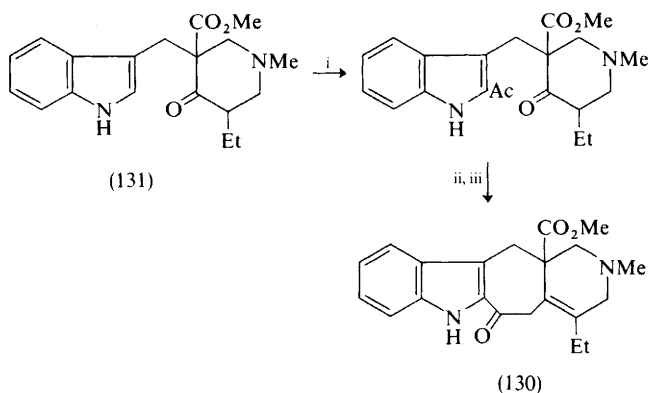

Reagents: i, MeCOCl , $\text{ZnCl}_2\text{-PhNO}_2$; ii, KOBu^+ , dioxan; iii, MeOH-HCl .

Scheme 23

Strychnine-Akuammicine-Condyllocarpine-Ellipticine Group. Diaboline has been shown¹⁴⁰ to occur in *Strychnos potatorum* L.; its 11-methoxy-derivative is found in the bark of *S. malacoclados* C. H. Wright,¹⁴¹ *S. amazonica*,^{127a} and *S. brachiata*, where it occurs in association with the Wieland-Gumlich aldehyde (deacetyldiaboline).^{127a} The leaves of *Cabucala erythrocarpa* var. *erythrocarpa* contain akuammicine,^{81c} which has also been isolated from *Pandaca ochracea*,¹²² together with dihydrocondyllocarpine and apparicine. These last two bases have also been found in *P. eusepala*,^{124a} and apparicine in *P. calcarea*¹³⁰ and *Muntafara sessilifolia*.¹³² The leaves of *Craspidospermum verticillatum* Boj. var. *petiolare* A. de

¹⁴⁰ H. Singh, V. K. Kapoor, J. D. Phillipson, and N. G. Bisset, *Phytochemistry*, 1975, **14**, 587.

¹⁴¹ R. Verpoorte and A. B. Svendsen, *Phytochemistry*, 1974, **31**, 2011.

Candolle, also from Madagascar, have so far yielded¹⁴² seven alkaloids, which include stemmadenine, desformylstemmadenine, condylocarpine, and andranginine. The *N*-oxide of vincanine (norfluorourarine) has been isolated from *Vinca erecta*,¹⁴³ four other alkaloids of this plant have been reinvestigated, and on the basis of the 100 MHz n.m.r. spectra the methoxy-group, previously assigned to position C-11, is now thought¹⁴⁴ to be at C-12 [(132)—(135)]. Vinervinine (132) is thus 12-methoxyakuammicine; the true 11-methoxyakuammicine is, however, a natural product, and occurs^{145a} in *Alstonia muelleriana*; its previous designation^{145b} as vinervinine is thus in error, and has now been corrected following re-examination of its n.m.r. spectrum. Angustimycine, recently isolated¹²¹ from *Amsonia angustifolia*, would appear to be the isomer of akuammicine with the double bond in the terminal (C-18—C-19) position, but there is as yet no mention of an obvious correlation with akuammicine.

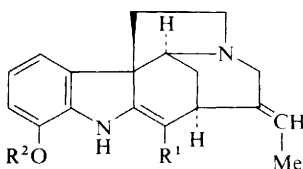

- Vinervinine (132) $R^1 = \text{CO}_2\text{Me}$, $R^2 = \text{Me}$
 Vinervine (133) $R^1 = \text{CO}_2\text{Me}$, $R^2 = \text{H}$
 Vincanidine (134) $R^1 = \text{CHO}$, $R^2 = \text{H}$
 Vincanine (135) $R^1 = \text{CHO}$, $R^2 = \text{Me}$

The structures previously proposed for holstiine, a constituent of *Strychnos holstii* Gilg. var. *reticulata* (Burt Davy et Honoré) Duvin. forma *condensata* Duvin. (*S. henningsii* Gilg.) and rindline, also from *S. henningsii*, have been discarded in favour of (136) and (137), respectively.^{146a} Holstiine clearly belongs to the *N*-methyl-*sec*-pseudostrychnine series (pK_a value, n.m.r., and mass spectra) in which the C-18—O linkage has been severed. Fragmentation at *a* (\rightarrow fragment at m/e 124) confirms this, and fragmentation at *b* to give a peak at $M^+ - 57$, together with n.m.r. data, confirm the presence of the unusual amide-hemiacetal function attached to N_a . Holstiline (138) behaves in all respects as an *O*-methylholstiine, and rindline (137) as an *ar*-methoxyholstiline. These bases thus belong to the tsilanine (139) series; holstiline is, in fact, *N*-methyl-*sec*-pseudotsilanine.^{146a} A minor base previously obtained^{146b} from *S. henningsii* and suspected to be *ar*-demethoxyrindline is presumably holstiline, but definite identification was not possible.

Huntermine, a remarkably stable alkaloid of *Hunteria eburnea*, which survives the usual methods for degrading quaternary salts and can be sublimed as its chloride or bromide salt, has the constitution (141).⁷² An indoxyl derivative obtained by

¹⁴² C. Kan-Fan, B. C. Das, H. P. Husson, and P. Potier, *Bull. Soc. chim. France*, 1974, 2839.

¹⁴³ M. Sharipov, V. M. Malikov, and S. Yu. Yunusov, *Khim. prirod. Soedinenii*, 1974, **10**, 263 (*Chem. Abs.*, 1974, **81**, 60 897).

¹⁴⁴ M. R. Yagudaev, V. M. Malikov, and S. Yu. Yunusov, *Khim. prirod. Soedinenii*, 1974, **10**, 260 (*Chem. Abs.*, 1974, **81**, 63 833).

¹⁴⁵ (a) J. M. Cook and P. W. Le Quesne, *J. Org. Chem.*, 1975, **40**, 1367; (b) D. E. Burke, G. A. Cook, J. M. Cook, K. G. Haller, H. A. Lazar, and P. W. Le Quesne, *Phytochemistry*, 1973, **12**, 1467.

¹⁴⁶ (a) N. G. Bisset, J. Bosly, B. C. Das, and G. Spiteller, *Phytochemistry*, 1975, **14**, 1411; (b) M. Spiteller-Friedmann and G. Spiteller, *Annalen*, 1968, **711**, 205.

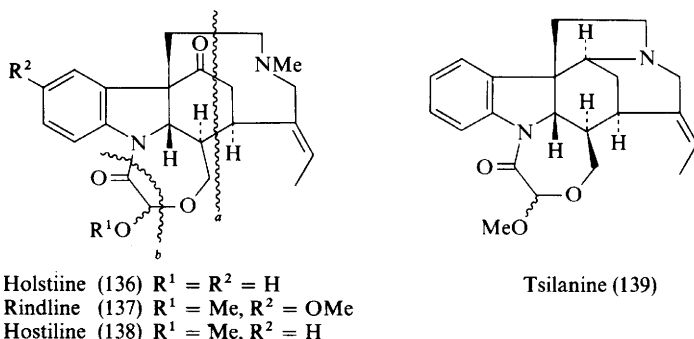

treatment with base is presumably (142). The biosynthesis of hunteracine from stemmadenine (140) can readily be rationalized as shown (Scheme 24); oxidation to the corresponding hydroxyindolenine, loss of the C-16 substituents and closure of the N_6 to C-2 bond gives hunteracine directly.⁷²

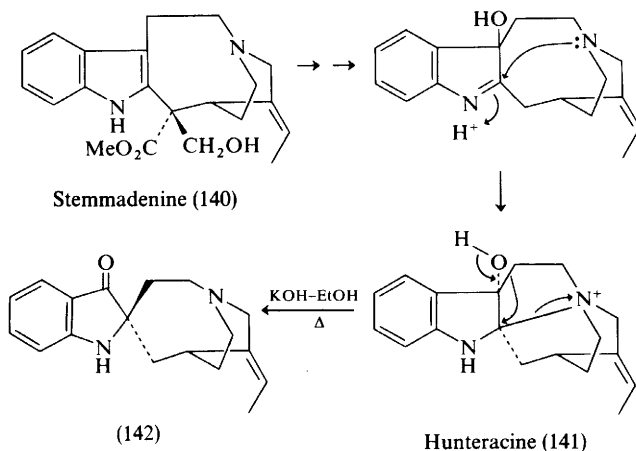

Scheme 24

The structure deduced recently^{147a} for andranginine (143) on the basis of 1H and ^{13}C n.m.r. spectra and a partial synthesis from precondylocarpine acetate has been independently confirmed by examination of the 1H n.m.r. spectrum of andrangininol (144) by the Fourier Transform Difference Spectra method.^{147b} This technique,

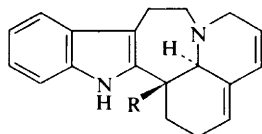

Andranginine (143) $R = CO_2Me$
 Andrangininol (144) $R = CH_2OH$

¹⁴⁷ (a) C. Kan-Fan, G. Massiot, A. Ahond, B. C. Das, H. P. Husson, P. Potier, A. I. Scott, and C. C. Wei, *J.C.S. Chem. Comm.*, 1974, 164; (b) G. Massiot, S. K. Kan, P. Gonord, and C. Duret, *J. Amer. Chem. Soc.*, 1975, **97**, 3277.

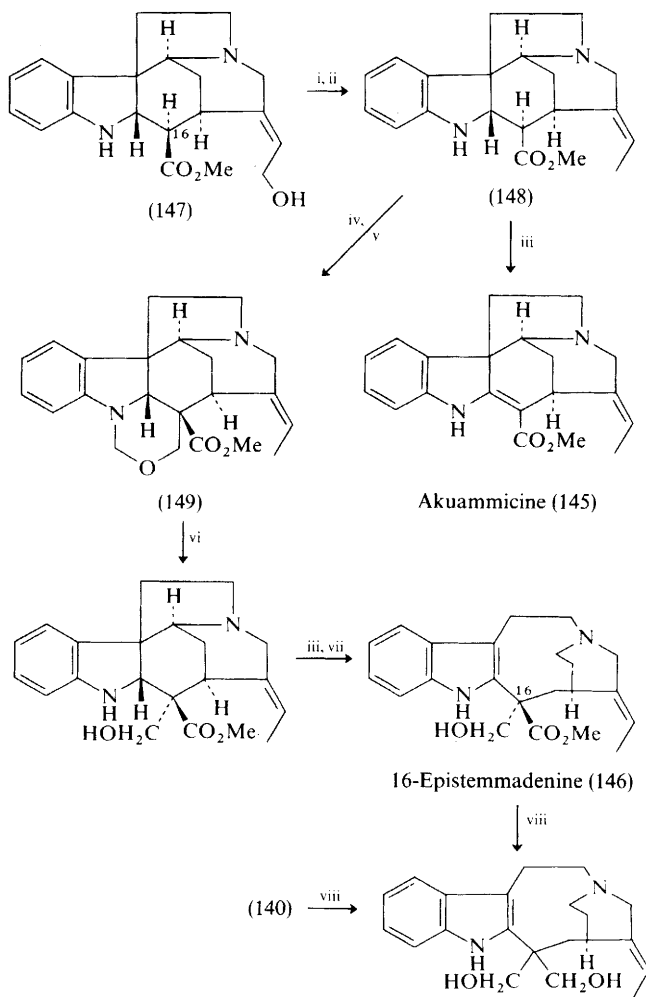

Reagents: i, HBr-AcOH; ii, Zn-AcOH; iii, Pb(OAc)₄; iv, NaH-HCO₂Me; v, CH₂O-NaH-DMSO; vi, MeOH-HCl; vii, NaBH₄-AcOH; viii, NaAlH₂(OCH₂CH₂OMe)₂.

Scheme 25

which promises to be widely applicable, involves the familiar double irradiation technique but instead of recording two complete spectra, only the differences are recorded and Fourier transformed. The simplified spectrum thus contains only signals owing to the protons monitored and those with which they are coupled. Other notable ¹H n.m.r. studies include a detailed examination of the impressively well-resolved spectra at 250 MHz of strychnine, neostrychnine, and 18-oxostrychnine.¹⁴⁸

¹⁴⁸ J. C. Carter, G. W. Luther, and T. C. Long, *J. Magn. Resonance*, 1974, **15**, 122; G. W. Luther, J. Valentini, and J. C. Carter, *ibid.*, p. 132.

X-Ray crystal data for iodostrychnine sulphonic acid have been reported^{149a} and the mode of packing of ellipticine in the crystal has been determined.^{149b}

The Tafel colour reaction has been re-examined¹⁵⁰ and a method, of potential value in synthesis, has been developed for the selective debenzoylation of *N*-benzyl quaternary salts; this involves¹⁵¹ the treatment of the salt at 0–5 °C with lithium *n*-propylmercaptide (PrSLi) in HMPA.

Scott *et al.*¹⁵² have published details of their studies^{118c} on the skeletal rearrangements and interconversions in the indole alkaloid series; these include, of course, transformations involving *Aspidosperma* and *Iboga* bases, as well as those of the *Strychnos* group, and some of them have recently been surrounded by controversy.^{118c} New transformations include the first syntheses¹⁵³ of akuammicine (145) and 16-epistemmaadenine (146) (Scheme 25) from the hydroxyester (147), itself prepared from strychnine *via* the Wieland–Gumlich aldehyde. This synthesis of 16-epistemmaadenine establishes for the first time the configuration at C-16. The ester (147) is known to have a non-epimerizable, equatorial methoxycarbonyl group at C-16, and the same would be expected of (148) and its *N*_a-formyl derivative, the anion from which undergoes an aldol reaction and subsequent reductive cyclization to give (149). The configuration at C-16 in (149) and 16-epistemmaadenine (146) follows, as does the configuration at C-16 in stemmadenine (140), since both (140) and (146) give rise to the same diol on reduction.¹⁵³

An interesting new synthesis¹⁵⁴ of the tetracyclic base (150) (Scheme 26), which involves as key stages the γ -alkylation of an α,β -unsaturated amide and a Witkop photocyclization, affords an alternative route to the synthesis of tubifoline, tubifolidine, and condyfoline, previously obtained from (150) by Harley-Mason and co-workers.

The synthesis of ellipticine (151) continues to attract considerable attention, owing to the reported anti-neoplastic activity of the alkaloid, and three new syntheses have been reported during the year. The route of Sainsbury *et al.*^{155a} is an improved modification on one reported earlier,^{155b} whereas the other syntheses¹⁵⁶ attempt to simulate, in a critical cyclization stage, a possible biosynthetic step. Scheme 27 illustrates one of these approaches^{156a} which, together with a variant reported simultaneously, involves the formation of the C-7—C-19 or possibly the C-19—C-20 bond. The second synthesis by Potier's group introduces the ethylidene group at a much earlier stage, but involves a similar cyclization, using the 15,16-dihydro-derivative of (152).

An improved synthesis¹⁵⁷ of olivacine (Scheme 28), and thereby guatambuine also, follows from an efficient three-stage preparation of the carbazole aldehyde

¹⁴⁹ (a) D. S. S. Dowda, L. Cartz, and S. Natarajan, *Acta Cryst.*, 1974, **B30**, 2524; (b) C. Courseille, B. Busetta, and M. Hospital, *ibid.*, p. 2628.

¹⁵⁰ K. Kaloy, L. Szabó, and O. Clauder, *Acta Pharm. Hung.*, 1974, **44**, 13 (*Chem. Abs.*, 1974, **81**, 120 842).

¹⁵¹ J. P. Kutney, G. B. Fuller, R. Greenhouse, and I. Itoh, *Synth. Comm.*, 1974, **4**, 183.

¹⁵² A. I. Scott and A. A. Qureshi, *Tetrahedron*, 1974, **30**, 2993; A. I. Scott and C. C. Wei, *ibid.*, p. 3003; A. I. Scott, P. C. Cherry, and C. C. Wei, *ibid.*, p. 3013.

¹⁵³ J. P. Kutney and G. B. Fuller, *Heterocycles*, 1975, **3**, 197.

¹⁵⁴ A. Wu and V. Snieckus, *Tetrahedron Letters*, 1975, 2057.

¹⁵⁵ (a) M. Sainsbury, B. Webb, and R. Schinazi, *J.C.S. Perkin I*, 1975, 289; (b) K. N. Kilminster and M. Sainsbury, *ibid.*, 1972, 2264.

¹⁵⁶ (a) R. Besselièvre, C. Thal, H. P. Husson, and P. Potier, *J.C.S. Chem. Comm.*, 1975, 90; (b) Y. Langlois, N. Langlois, and P. Potier, *Tetrahedron Letters*, 1975, 955.

¹⁵⁷ J. P. Kutney and D. S. Grierson, *Heterocycles*, 1975, **3**, 171.

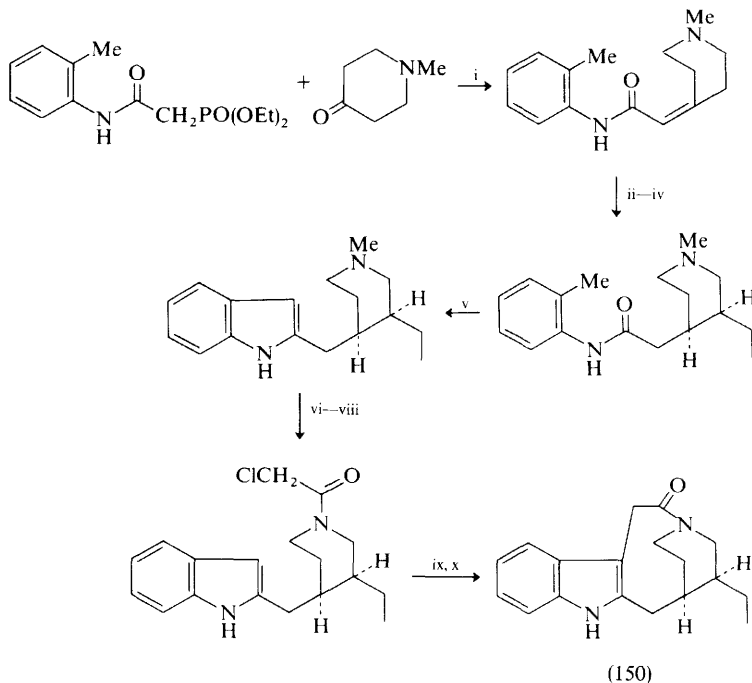

Reagents: i, NaOEt-EtOH; ii, 2BuⁿLi-TMEDA-Et₂O; iii, EtBr-Et₂O; iv, H₂Pd/C, EtOH; v, Bu^tOK, 340 °C; vi, ClCOCH₂CCl₃, C₆H₆; vii, Zn-AcOH-MeOH; viii, ClCO-CH₂Cl, NaOH; ix, *hν*-EtOH-H₂O-Na₂CO₃; x, LiAlH₄-THF.

Scheme 26

(153) from the keto-ester (154), which was cyclized, dehydrated, and dehydrogenated in one high-yielding procedure. The aldehyde (153) had previously been converted into olivacine by a familiar sequence.

Aspidospermine-Aspidofractine-Eburnamine Group. Minor constituents of the leaves of *Amsonia tabernaemontana* include epivincadine, (+)-14,15-dehydroepivincadine;* and (+)-14,15-dehydrovincadine,¹⁵⁸ new extractions of *A. angustifolia* have yielded⁹⁵ (-)-quebrachamine, (+)-vincadifformine, (+)-eburnamonine, and (-)-eburnamenine. *Vinca erecta* contains 11-methoxyvincadifformine (155),⁸⁴ venalstonine, 14,15-dehydro-3-oxokopsinine,¹⁴³ kopsinine oxide, and pseudokopsinine oxide.¹²⁵ Venalstonine, tabersonine, and vincoline are among the constituents of the aerial parts of *V. libanotica*.⁷⁹ (+)-Voaphylline has been reported to be present in the seeds of *Tabernaemontana iboga*¹⁵⁹ and in two varieties of *Tabernaemontana divaricata*,¹³³ one of these varieties also

¹⁵⁸ B. Zsador, L. Décsi, K. Otta, M. Szilasi, and P. Kaposi, *Acta Pharm. Hung.*, 1974, **44**, 74 (*Chem. Abs.*, 1975, **82**, 28 546).

¹⁵⁹ R. Goutarel, J. Poisson, G. Croquelois, Y. Rolland, and C. Miet, *Ann. pharm. franç.*, 1974, **32**, 521.

* Taylor-Le Men numbering [see (155)].

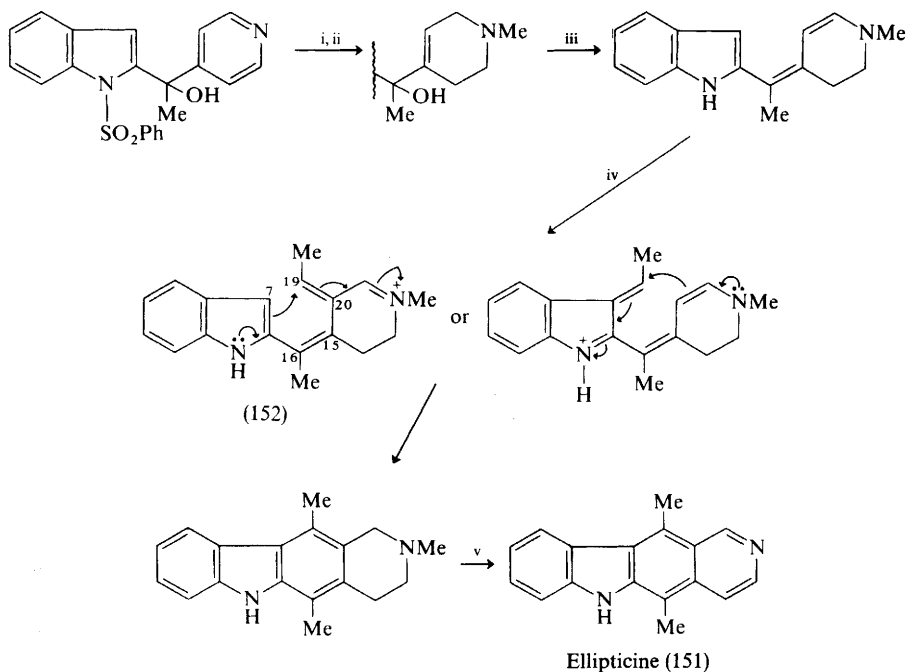

Reagents: i, MeI; ii, NaBH₄; iii, KOBu^t-DMSO; iv, MeCH=NMe₂⁺OAc, AcOH; v, Pd-C, decalin.

Scheme 27

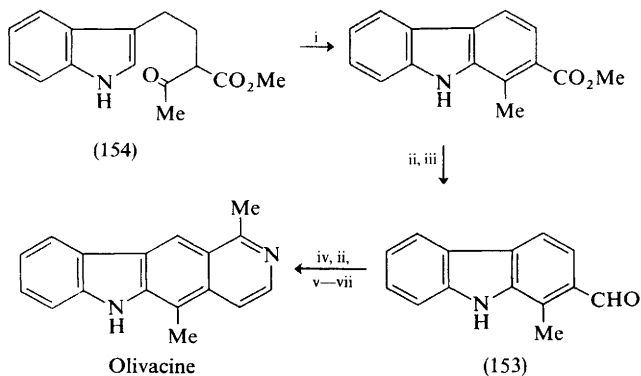

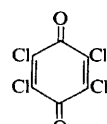
Reagents: i, , 2% HCl-MeOH-C₆H₆; ii, LiAlH₄; iii, Jones' reagent; iv, MeNO₂; v, Ac₂O; vi, POCl₃; vii, Pd-C.

Scheme 28

contains lochnericine. Lochnericine has been isolated from both *Cabucala fasciculata*^{81a} and *C. erythrocarpa*,^{81c} the latter species also contains (-)-minovincine. Tabersonine is present in the fruits of *Voacanga grandifolia*,¹²³ (+)-16-epi-14,15-dehydrovincamine and apparicine are present in the leaves of *Pandaca ochraceus*,¹²² apparicine occurs in *P. calcarea*,¹³⁰ and pericalline and vindoline occur in *Catharanthus trichophyllus* roots.⁷⁷ A new minovincine derivative, echitoserpine, from the fruits of *Alstonia venenata*, proves to be the unusual myristicin acid ester (156).¹⁶⁰ The leaves of *Craspidospermum verticillatum* have so far yielded four

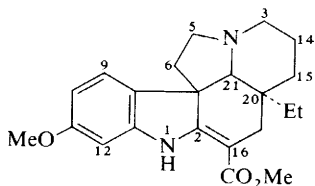

(155)

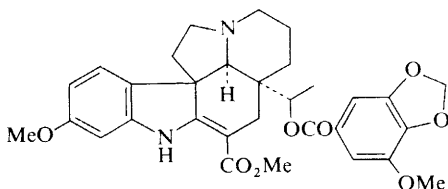

Echitoserpine (156)

known alkaloids and three new ones,¹⁴² the known bases include venalstonine and 11-methoxytabersonine, while one of the new ones is andrangine, also a constituent of the leaves of *Crioceras dipladeniiflorus*, together with 12-methoxyvoaphylline and a bis-indole base, cryophylline.¹⁶¹ The structure and absolute configuration of andrangine (157) follow from its conversion (Scheme 29) into the unsaturated base (158), also obtained from (+)-vallesamidine.¹⁴² The alkaloid composition of the stem bark of *C. dipladeniiflorus* is similar to that of the leaves and root bark.

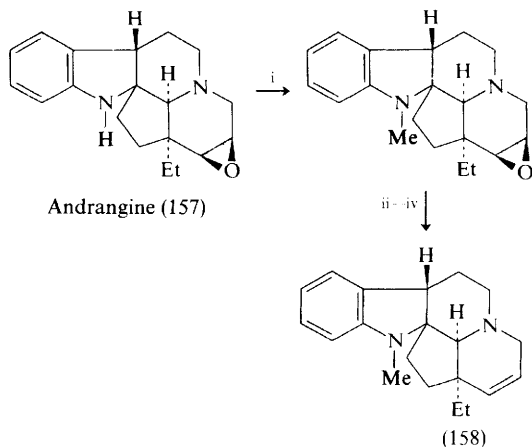

Reagents: i, CH₂O-H⁺, H₂O-NaCNBH₃; ii, LiAlH₄, Et₂O; iii, PhCOCl, py; iv, 260 °C.

Scheme 29

¹⁶⁰ P. L. Majumder, B. N. Dinda, A. Chatterjee, and B. C. Das, *Tetrahedron*, 1974, **30**, 2761.

¹⁶¹ J. Bruneton, A. Bouquet, and A. Cavé, *Phytochemistry*, 1974, **13**, 1963.

Seven alkaloids have been isolated,¹⁶² including tabersonine, voaphylline, Δ^{14} -vincamine, 16-epi- Δ^{14} -vincamine, 12-methoxy- Δ^{14} -vincamine, and Δ^{14} -apovincamine, which have previously been isolated from the root bark. The seventh alkaloid criocerine, is new, and has been assigned the structure and absolute configuration (159), on the basis of its spectroscopic properties and its partial synthesis by a Polonovski reaction on the *N*-oxide of Δ^{14} -vincamine.¹⁶²

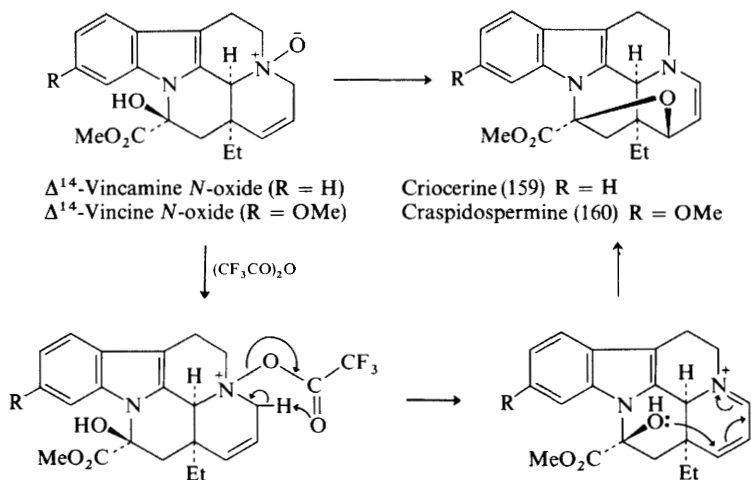

The 11-methoxy derivative of (159), craspidospermine (160), had been isolated from *Craspidospermum verticillatum* just prior to this work, and the partial synthesis of criocerine was based on a similar partial synthesis of craspidospermine from the *N*-oxide of Δ^{14} -vincine.¹⁶³

The structure and relative stereochemistry recently assigned^{1b} to the very closely related alkaloid, vincarodine (161), have been independently confirmed¹⁶⁴ by X-ray crystal structure analysis, but the absolute configuration remains to be determined.

The supporting evidence (mainly ¹H, ¹³C n.m.r., and mass spectra) for the structure of cuanzine (162), from *Voacanga chalongiana*,^{1c} has now been published.^{165a} The ¹³C n.m.r. data are shown in structure (162), and a comparison with the chemical shifts for the corresponding atoms in vincamine (163) provides convincing evidence for the placing of the ether linkage and the aromatic methoxy-group. The c.d. spectrum of cuanzine, very similar to that of 16-epivincamine, indicates that (162) is also the absolute configuration. In connection with this study the C-21 epimerization of vincamine was investigated^{165b} by means of chromic acid oxidation to the 21, *N*₂-dehydro-derivative, followed by reduction. Unexpectedly, the product was found to

¹⁶² J. Bruneton, C. Kan-Fan, and A. Cavé, *Phytochemistry*, 1975, **14**, 569.

¹⁶³ H. P. Husson, C. Kan-Fan, and P. Potier, unpublished work, quoted in ref. 162.

¹⁶⁴ J. P. Kutney, G. Cook, J. Cook, I. Itoh, J. Clardy, J. Fayos, P. Brown, and G. H. Svoboda, *Heterocycles*, 1974, **2**, 73.

¹⁶⁵ E. Bombardelli, A. Bonati, B. Gabetta, E. M. Martinelli, G. Mustich, and B. Danieli, (a) *Tetrahedron*, 1974, **30**, 4141; (b) *Fitoterapia*, 1975, **46**, 51.

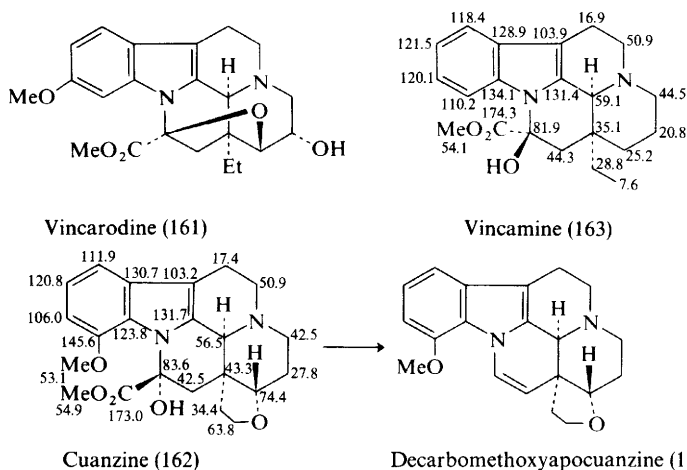

contain two epimers, which were identified as 16-*epi*-21-*epi*vincamine and 21-*epi*vincamine. The ^1H and ^{13}C n.m.r. spectra of all four C-16 and C-21 epimers of vincamine were recorded.

The second of these new alkaloids, decarbomethoxyapocuanzine, exhibits an n.m.r. spectrum similar to that of cuanzine, but lacking the ester and hydroxyl groups and the C-17 AB system. The structure (164) follows from these observations, and from the transformation of cuanzine into decarbomethoxyapocuanzine by vigorous reduction with NaBH_4 followed by oxidation with periodic acid.¹⁶⁶

A second group of workers has concurred^{167a} that the correct structure^{1d} for vindolinine (165) contains a C-2—C-19, and not a C-6—C-19, bond. This conclusion was based on a study of the 300 MHz spectrum in which the superior resolution gave greater detail than was obtained in the 60 MHz spectrum study in 1964. The French group^{167b} have added some chemical evidence, including a diagnostic correlation with known *Aspidosperma* alkaloids. Thus, reaction of vindolinine with iodine-sodium carbonate solution affords an iodo-compound, which on hydrogenation yields a mixture of (–)-tabersonine and (–)-vincadifformine (Scheme 30). This

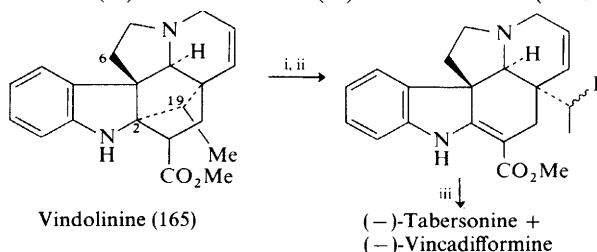

Reagents: i, I_2 , THF; ii, Na_2CO_3 , H_2O ; iii, H_2 -Ni.

Scheme 30

¹⁶⁶ E. Bombardelli, A. Bonati, B. Danieli, B. Gabetta, E. M. Martinelli, and G. Mustich, *Experientia*, 1974, **30**, 979.

¹⁶⁷ (a) L. J. Durham, J. N. Shoolery, and C. Djerassi, *Proc. Nat. Acad. Sci. (U.S.A.)*, 1974, **71**, 3797; (b) P. Rasoanaivo, N. Langlois, and P. Potier, *Tetrahedron Letters*, 1974, 3669; (c) C. Riche and C. Pascard-Billy, unpublished work, quoted in ref. 167b.

correlation also establishes the stereochemistry of vindolinine, apart from the configuration at C-16 and C-19. However, the chemical shift of the C-18 methyl group in vindolinine and 19-epivindolinine indicate the 19*R*-configuration for vindolinine, which has been confirmed, with the C-16 configuration and the absolute configuration, by X-ray crystal structure analysis.^{167c}

As mentioned earlier¹⁴ an exactly similar structural revision needs to be made for pseudokopsinine (166) and this has now been formally achieved by the first X-ray determination¹⁶⁸ of the structure and absolute configuration of an alkaloid in this group.

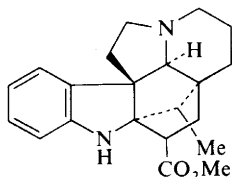

Pseudokopsinine (166)

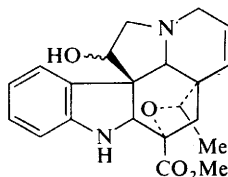

Vincoline (167)

Vinca libanotica is a new source of vincoline,^{169a} an alkaloid first isolated in 1964 from *Catharanthus roseus*.^{169b} Vincoline^{169a} has the structure (167), which possesses two uncommon features, namely, the presence of an ether bridge between C-19 and C-16, and an oxidized C-6. Biogenetically this structure could arise from a C-16-hydroxy-2,16-dihydrominovincinine *via* nucleophilic displacement of an appropriate leaving group derived from the C-19 hydroxy-group by the oxygen attached to C-16.

Deacetylathovaline (168) has been found to occur together with cathovaline (169) in *C. ovalis*, and the structures of these two alkaloids have been established by correlation with vindorosine (170);^{170a} the structure previously proposed^{170b} for cathovaline is thus confirmed, and the stereochemical detail also becomes evident. Vindorosine (170) (and vindoline) apparently do not give an *N*_b-oxide under the usual conditions, owing to the presence of a strong hydrogen bond between the tertiary hydroxy-group and the lone electrons on *N*_b. The acetyl derivative (171), however, behaves normally and from the product deacetylvindorosine *N*_b-oxide (172) can be obtained, and transformed into deacetylathovaline by a modified Polonovski reaction,^{170a} presumably *via* the enamine (173) (Scheme 31).

*N*_a-Desmethylvindoline (8–10%) is found among the products of the microbiological conversion of vindoline by means of *Streptomyces albobriseolus*.¹⁷¹

Büchi has presented an interim report^{172a} on progress towards the total synthesis of vinblastine. The general strategy involves the condensation of vindoline (174)

¹⁶⁸ S. M. Nasyrov, V. G. Andrianov, and Y. T. Struchkov, *J.C.S. Chem. Comm.*, 1974, 979; S. M. Nasyrov, V. G. Andrianov, Y. T. Struchkov, M. R. Yagudaev, V. M. Malikov, and S. Yu. Yunusov, *Khim. prirod. Soedinenii*, 1974, 811.

¹⁶⁹ (a) G. H. Aynilian, S. G. Weiss, G. A. Cordell, D. J. Abraham, F. A. Crane, and N. R. Farnsworth, *J. Pharm. Sci.*, 1974, **63**, 536; (b) G. H. Svoboda, M. Gorman, and R. H. Tust, *Lloydia*, 1964, **27**, 203.

¹⁷⁰ (a) L. Diatta, Y. Langlois, N. Langlois, and P. Potier, *Bull. Soc. chim. France*, 1975, 671; (b) N. Langlois and P. Potier, *Compt. rend.*, 1971, **273**, C, 954.

¹⁷¹ N. Neuss, D. S. Fukuda, D. R. Brannon, and L. L. Huckstep, *Helv. Chim. Acta*, 1974, **57**, 1891.

¹⁷² (a) G. Büchi, *Chimia*, 1975, **29**, 172; (b) G. Büchi, K. E. Matsumoto, and H. Nishimura, *J. Amer. Chem. Soc.*, 1971, **93**, 3299.

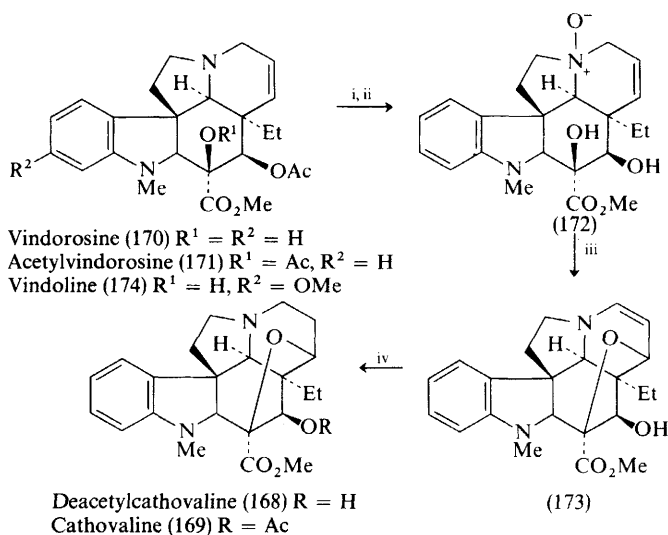

Reagents: i, RCO_3H ; ii, hydrolysis; iii, $(CF_3CO)_2O, CH_2Cl_2$; iv, $MeOH, NaBH_4$.

Scheme 31

with 16-methoxycarbonylvelbanamine, and for this purpose the total synthesis of vindoline is being investigated. However, the cyclization of the intermediate (175a), analogous to the cyclization of the desmethoxy-derivative (175b) in Büchi's elegant vindorosine synthesis [*i.e.* (175b) \rightarrow (177b)],^{172b} gave only 9% of the desired tetracyclic aminoketone (177a); instead, the electron-releasing aromatic methoxy-group encouraged a Wagner–Meerwein shift in the intermediate (176a), with formation of the undesired indole aminoketone (178a). This difficulty was circumvented by introduction of the electron-withdrawing tosyloxy-group (175c), which

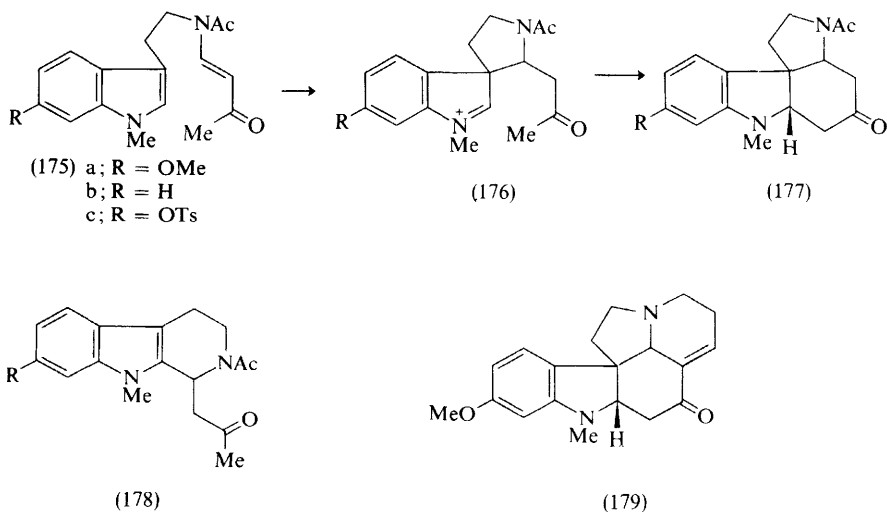

allowed the smooth preparation of (177c), elaboration of which has so far reached the pentacyclic ketone (179).

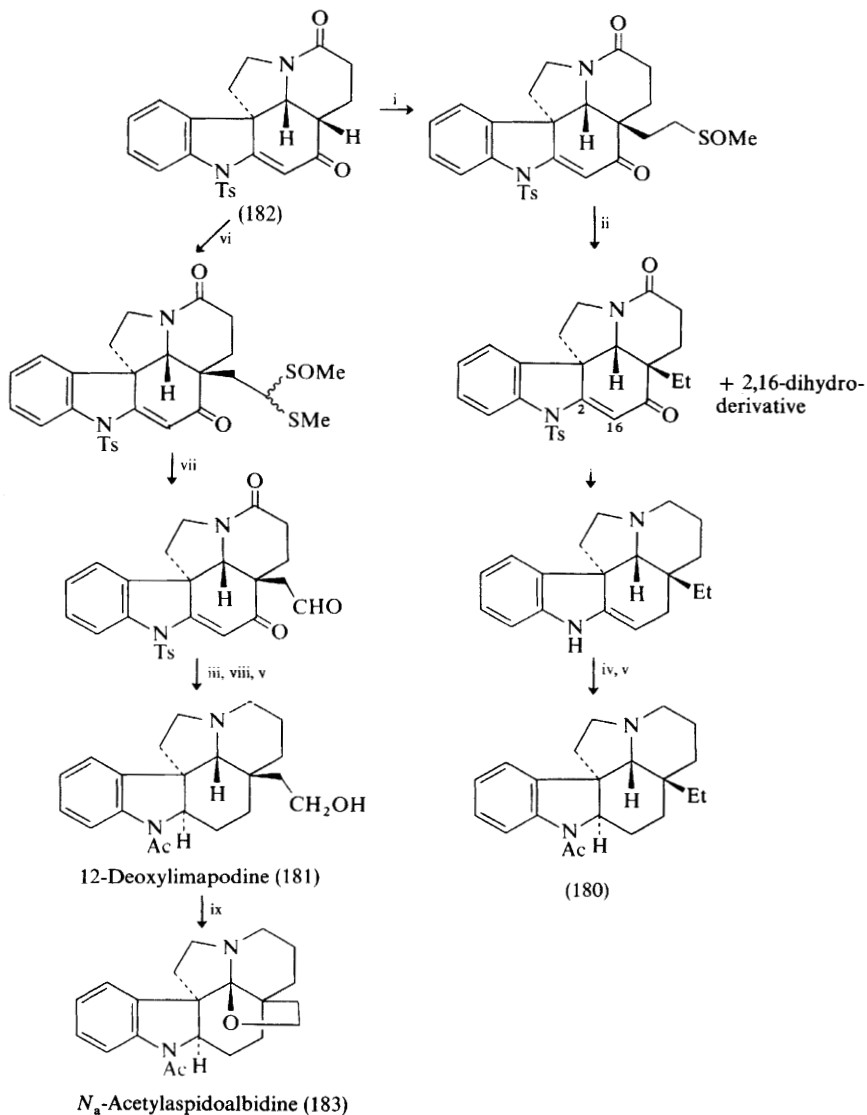

Reagents: i, $\text{MeSOCH}=\text{CH}_2$, LiNPr_2 , THF; ii, Raney Ni, 60 °C; iii, LiAlH_4 , $(\text{MeOCH}_2)_2$, reflux; iv, AcCl , CH_2Cl_2 , K_2CO_3 ; v, PtO_2 - H_2 , EtOH-HCl , 4 atm.; vi, $\text{CH}_2=\text{C}(\text{SMe})\text{-SOMe}$, LiNPr_2 , $(\text{MeOCH}_2)_2$; vii, HClO_4 - H_2O , MeCN ; viii, $\text{AcCl-CH}_2\text{Cl}_2$, 4% $\text{NaOH-H}_2\text{O}$; ix, $\text{Hg}(\text{OAc})_2$, $\text{AcOH-H}_2\text{O}$, 65 °C.

Scheme 32

Recent synthetic work in the aspidospermine group includes a new synthesis of (\pm)- N_a -acetylaspidospermidine (180),^{173a} the first synthesis of an *Aspidosperma* alkaloid containing a functionalized two-carbon unit at C-20 (Scheme 32),^{173b} and a synthesis of (\pm)-14,15-didehydroapidospermine.^{174a}

The syntheses by Ban and co-workers of both N_a -acetylaspidospermidine (180) and deoxylimapodine (181) (Scheme 32) utilize the important pentacyclic ketone (182), prepared earlier. The critical stage in both syntheses is a Michael reaction, apparently stereospecific, of (182) with methyl vinyl sulphone [\rightarrow (180)] and keten thioacetal monoxide [\rightarrow (181)], respectively. The later stages in the synthesis are unexceptional. Mercuric acetate oxidation of deoxylimapodine enabled the first synthesis of N_a -acetylaspidoalbidine (183) to be completed.^{173b}

The synthesis of 14,15-didehydroapidospermine (184), which affords a third route to the important group of alkaloids containing a double bond in ring D, involved the synthesis^{174a} of the unsaturated bicyclic aminoketone (185) (Scheme 33), and completion of the synthesis by the route adopted by Stork and Dolfini^{174b} in the original aspidospermine synthesis.

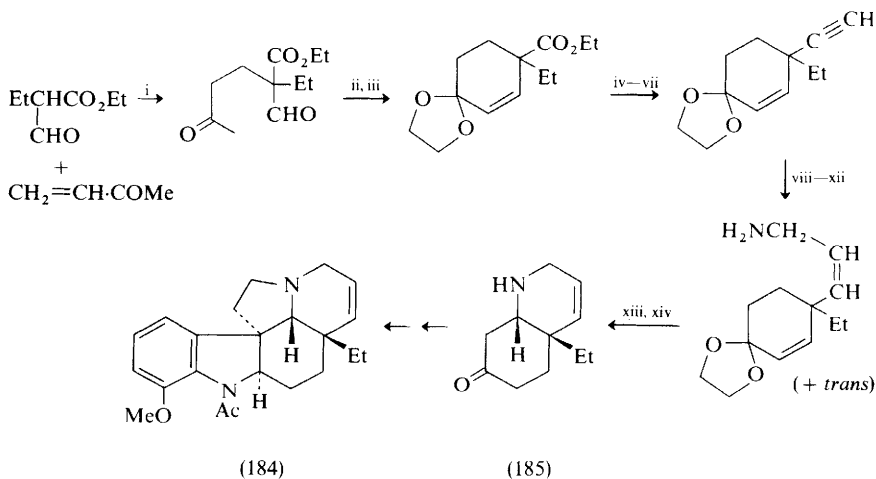

Reagents: i, Bu^tOH-KOBu^t; ii, C₆H₆, C₅H₁₁N-AcOH, azeotropic removal of H₂O; iii, ketalization; iv, LiAlH₄, Et₂O; v, py-SO₃-DMSO, NEt₃; vi, ClCH=PPH₃, THF; vii, KOBu^t, glyme, HMPA; viii, Li salt, glyme-CH₂O; ix, H₂-PtO₂, MeCO₂Et, NEt₃; x, LiMe, C₆H₆-MeSO₂Cl; xi, NaN₃, DMSO; xii, Al-Hg, Et₂O-MeOH-H₂O; xiii, Hydrolysis; xiv, Al₂O₃ chromatography.

Scheme 33

Mention has already been made of the publication of details of the extensive work¹⁵² by Scott and co-workers on skeletal transformations and interconversions in the *Aspidosperma-iboga* series. Other transformations include a rearrangement of

¹⁷³ (a) K. Seki, T. Ohnuma, T. Oishi, and Y. Ban, *Tetrahedron Letters*, 1975, 723; (b) Y. Ban, T. Ohnuma, K. Seki, and T. Oishi, *ibid.*, p. 727.

¹⁷⁴ (a) S. S. Klioze and F. P. Darmory, *J. Org. Chem.*, 1975, **40**, 1588; (b) G. Stork and J. E. Dolfini, *J. Amer. Chem. Soc.*, 1963, **85**, 2872.

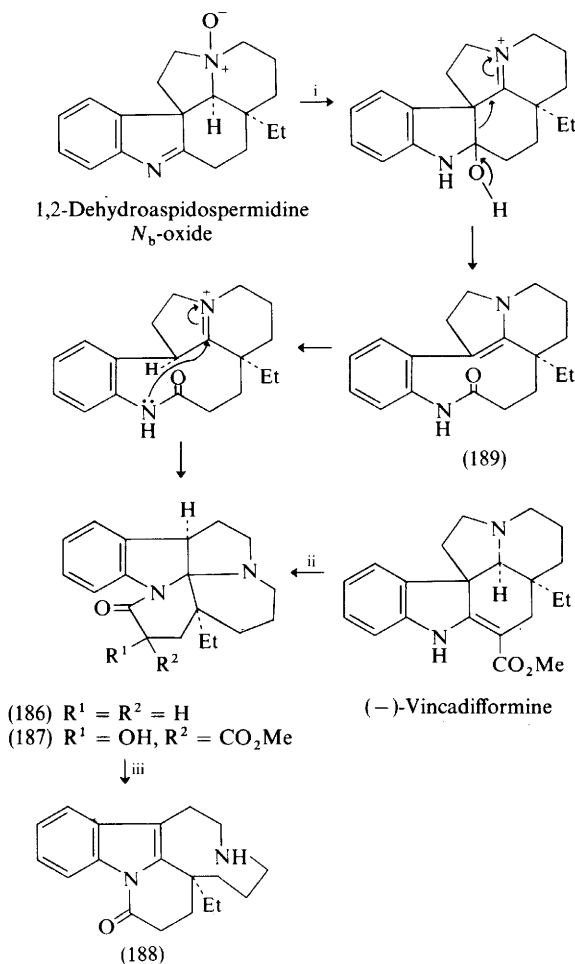

Reagents: i, PPh_3 , AcOH; ii, *m*-ClC₆H₄CO₂H; iii, 30% HCl, 2 h, 90 °C.

Scheme 34

1,2-dehydroaspidospermidine *N_b*-oxide to the pentacyclic lactam (186) on treatment with triphenylphosphine^{175a} (an extension of an earlier study), and an exactly analogous rearrangement of (-)-vincadifformine to the lactam-ester (187) on reaction with an excess of *m*-chloroperbenzoic acid.¹⁷⁶ Both (186) and (187) are converted by mineral acid into products containing an *N*-acylindole chromophore; (186), for example, yields (188). The proposed mechanism for the formation of (186) proceeds *via* an intermediate dihydrorhazininam (189) previously invoked by

¹⁷⁵ (a) G. Hugel, J. Lévy, and J. Le Men, *Tetrahedron Letters*, 1974, 3109; (b) G. Hugel, B. Gourdir, J. Lévy, and J. Le Men, *ibid.*, p. 1597.

¹⁷⁶ G. Croquelois, N. Kunesch, and J. Poisson, *Tetrahedron Letters*, 1974, 4427.

Smith and co-workers¹⁷⁷ to account for the course of the conversion of 1,2-dehydroaspidospermidine into rhazinilam (Scheme 34).

A new synthesis¹⁷⁸ of vincamine (163) (Scheme 35) makes use of the optically pure acid (190), and the stereoselective introduction of the second asymmetric centre

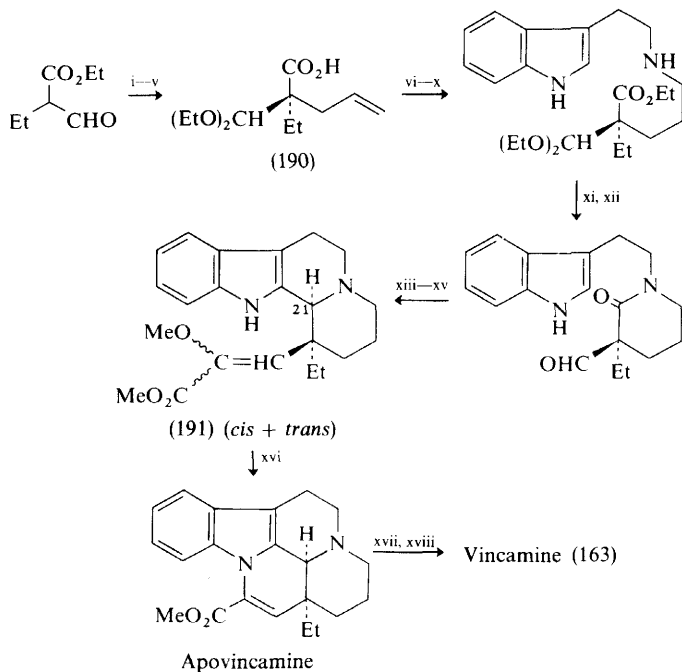

Reagents: i, $\text{CH}_2=\text{CHCH}_2\text{Br}$, EtNPr_2^+ ($\rightarrow O$ - + C -alkylation); ii, 210°C [O -allyl isomer \rightarrow (Claisen) C -allyl isomer]; iii, HC(OEt)_3 , TsOH ; iv, $\text{KOH-H}_2\text{O-EtOH}$; v, Resolve with L (+)-pseudoephedrine; vi, Et_2SO_4 , K_2CO_3 ; vii, BH_3 , THF ; viii, $\text{KOH-H}_2\text{O}$; ix, TsCl , py ; x, tryptamine; xi, imidazole, 130°C ; xii, AcOH , H_2O ; xiii, $(\text{MeO})_2\text{PO-CH(OMe)CO}_2\text{Me}$, NaH , THF ; xiv, POCl_3 ; xv, H_2 -Pd/C, NEt_3 ; xvi, HBr , AcOH ; xvii, HBr , -78°C ; xviii, hexane, -50°C , 10 M $\text{KOH-H}_2\text{O}$, then $(\text{NH}_4)_2\text{SO}_4$, H_2O , -40° to -5°C .

Scheme 35

(C-21) by hydrogenation of a Bischler cyclization product [formation of (191)]. The unexpectedly resistant enol ether function in (191) required vigorous hydrolytic conditions, hence the resulting apovincamine, presumably obtained *via* dehydration of vincamine, had to be reconverted into vincamine, a stage not previously realized.¹⁷⁸

A new synthesis¹⁷⁹ of the eburnamine ring system, which has so far resulted in the synthesis of (\pm)-dihydroeburnamenine (not yet known, however, as a natural product), takes advantage of the rearrangement of benzyldenequinuclidones to tetrahydropyridoindoles.

¹⁷⁷ A. M. Ratcliffe, G. F. Smith, and G. N. Smith, *Tetrahedron Letters*, 1973, 5179.

¹⁷⁸ P. Pfäffli, W. Oppolzer, R. Wenger, and H. Hauth, *Helv. Chim. Acta*, 1975, **58**, 1131.

¹⁷⁹ D. L. Coffen, D. A. Katonak, and F. Wong, *J. Amer. Chem. Soc.*, 1974, **96**, 3966.

Joule and co-workers¹⁸⁰ have described the synthesis of the pyridocarbazole (192) and derivatives containing a partially-reduced ring D, which are potential intermediates in the synthesis of the rare alkaloid subincanine, whose structure has not yet been unambiguously defined.

Ibogamine-Cleavamine Group. (-)-Coronaridine has been isolated from the seeds of *Tabernaemthe iboga*¹⁵⁹ and, together with voacangine, from one variety of *Tabernaemontana divaricata*;¹³³ it also occurs in the root bark of *Gabunia eglandulosa*^{124b,181} in association with (-)-isovoacangine^{124b} and four new alkaloids. Two of these bases prove to be (-)-3-hydroxyisovoacangine (193) and 3-hydroxycoronaridine (194); the structure of the former was established by its preparation from isovoacangine by means of iodine in a benzene-water mixture.^{124b} The remaining two alkaloids, eglandine (195) and eglandulosine (196), are further oxidation products of coronaridine,¹⁸¹ and have also been found in *Muntafara sessilifolia*,¹³² an apparently prolific source of alkaloids, which also contains (-)-coronaridine, (-)-isovoacangine, 11-methoxyeglandine (197), and 11-methoxyeglandulosine (198). In consonance with these structures both eglandine

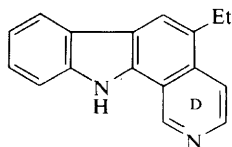

(192)

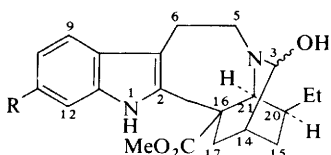

3-Hydroxyisovoacangine (193) R = OMe
3-Hydroxycoronaridine (194) R = H

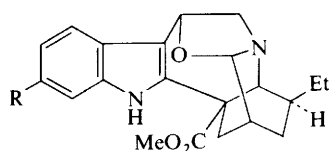

Eglandine (195) R = H
3,6-Oxido-isovoacangine (197) R = OMe
(11-Methoxyeglandine)

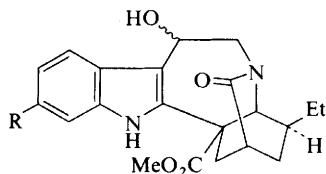

Eglandulosine (196) R = H
(-)-6-Hydroxy-3-oxo-isovoacangine
(198) R = OMe
(11-Methoxyeglandulosine)

and eglandulosine give rise to coronaridinol as one of the products of reduction by LiAlH_4 , and can themselves be prepared from coronaridine by oxidation with iodine and sodium bicarbonate in aqueous tetrahydrofuran.¹⁸¹ Similarly, 11-methoxyeglandine and 11-methoxyeglandulosine afford isovoacanginol on reduction¹³² with LiAlH_4 .

The *Pandaca* genus also appears to be a rich source of alkaloids of this group. *P. ochrascens* contains¹²² (-)-ibogaine, (-)-ibogaline, (-)-iboluteine, and two new

¹⁸⁰ D. Cohlakakis, G. J. Hignett, K. V. Lichman, and J. A. Joule, *J.C.S. Perkin I*, 1974, 1518.

¹⁸¹ J. Le Men, P. Potier, L. Le Men-Olivier, J. M. Panas, B. Richard, and C. Potron, *Bull. Soc. chim. France*, 1974, 1369.

alkaloids, 19-epi-iboxygaine and 19-epi-iboxygaline. These last two bases give mass spectra identical with those of their epimers, and by reduction (LiAlH_4) of their tosylates, afford (–)-ibogaine and (–)-ibogaline respectively. From a comparison of molecular rotation differences in the ibogaine–voacangine series in which C-19 carries a hydroxy-group, the 19*R*-configuration has been assigned¹²² to 19-epi-iboxygaine, 19-epi-iboxygaline, and 19-epivoacangarine; voacangarine, iboxygaine, iboxygaline, isovoacristine, heyneanine and iso-iboxygaine then have the 19*S*-configuration.

P. speciosa Mgf. appears to contain *Iboga* alkaloids exclusively, unlike the other *Pandaca* species so far extracted. The six alkaloids identified are (–)-voacangine, (–)-voacangarine, (–)-ibogaine, (–)-iboxygaine, iboluteine, and a bisindole alkaloid, descarbomethoxyvoacamine.¹⁸² *P. eusepala* has yielded nine alkaloids,^{124a} among which are (–)-ibogaine, (–)-19-epivoacangarine, (+)-ibogaine hydroxyindolenine, and three new alkaloids which can be prepared from catharanthine, namely, (+)-20*R*-dihydrocleavamine (199a), (–)-20*S*-dihydrocleavamine (199b), and (+)-20*S*-1,2-dehydropseudoaspidospermidine (200).

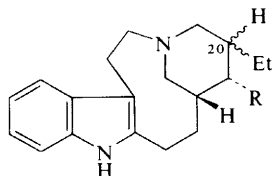

(199a) R = H, α -Et, β -H at C-20
 (199b) R = H, β -Et, α -H at C-20
 Capurinine (201) R = OH, α -Et,
 β -H at C-20

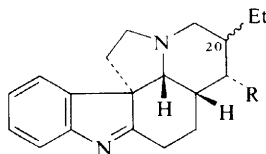

(200) β -Et at C-20, R = H
 (202) α -Et at C-20, R = OH

(+)-Capurinine and (+)-capurionidine are two closely related bases isolated from *Capurionetta elegans* Mgf.¹⁸³ Capurinine behaves in all respects as a hydroxydihydrocleavamine, which is confirmed by the preparation of two diastereoisomers of capurinine by the *anti*-Markownikov hydration of cleavamine, and by the production of (–)-cleavamine on dehydration of capurinine. Capurinine is thus a hydroxydihydrocleavamine in which the hydroxy-group and the C-20 hydrogen are *trans*-oriented, and the complete structure and absolute configuration, the remaining features of which were established by X-ray analysis of its acetate, are as given in (201). Its congener, capurionidine, can be converted into capurinine by reduction with NaBH_4 in the presence of alkali, and hence has structure (202).

Pandoline and pandine have again been encountered, in *Pandaca calcarea*, *P. debrayi*,¹³⁰ and in *P. caducifolia*,¹³¹ which contains other bases of the pseudoaspidospermidine group, namely, (+)-20*R*-pseudovincadifformine (203), (+)-pseudotabersonine (204), and (+)-20-epipandoline (205). The behaviour of pandine is in accord with structure (206),¹⁸⁴ thus, it contains an anilinoacrylate unit (spectra, behaviour on reduction) and a HO—C—Et grouping (mass spectrum), and in general shows similarity to pandoline, but since it contains no further unsaturation

¹⁸² M. C. Lévy, M. M. Debray, L. Le Men-Olivier, and J. Le Men, *Phytochemistry*, 1975, **14**, 579.

¹⁸³ I. Chardon-Loriaux and H. P. Husson, *Tetrahedron Letters*, 1975, 1845.

¹⁸⁴ J. Le Men, M. J. Hoizey, G. Lukacs, L. Le Men-Olivier, and J. Lévy, *Tetrahedron Letters*, 1974, 3119.

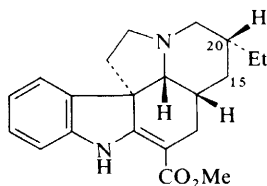

(203)

(204) 15,20-Dehydro

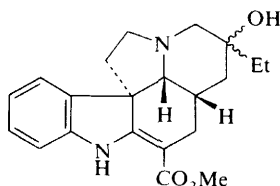

(205)

it must contain an extra ring. The deduction of structure (206) relied heavily on ^1H and ^{13}C n.m.r. spectroscopy, and particularly on the signals owing to protons at C-3, C-17, and C-21 in 2,16-dihydropandine, and the signal owing to C-21 itself. The

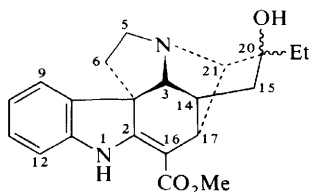

Pandine (206)

t.l.c. behaviour, and the reluctance of pandine to quaternize, suggest¹⁸⁴ that the hydroxy-group is disposed *cis* with respect to the lone electrons on N_b .

Some interesting transformations in the voacangine-conopharyngine group include¹⁸⁵ the fragmentation of voacanginol and conopharynginol tosylates (207 and 208) with triethylamine to voenamamine (209) and conoenamine (210). An additional product from conopharynginol tosylate was the aziridinium salt (211) which is susceptible to nucleophilic attack at positions 16 and 21; sodium borohydride, for example, gives both (212) and (213) (Scheme 36).

Details of the Czech group's chiroptical studies of the *Iboga* and *Voacanga* alkaloids, summarized previously,^{186a} have now been published.^{186b}

Büchi's synthesis of β -carbomethoxyvelbanamine (214), required for the synthesis of vinblastine, has been reported in brief.^{172a} The ingenious route adopted is outlined in Scheme 37. The formation of the bridged ring system was achieved from the tetracyclic intermediate (215) by internal quaternization of its tosylate followed by nucleophilic fission of the C-3 to N_b bond by means of cyanide.

4 Biogenetically Related Quinoline Alkaloids

The complete data for eight *Cinchona* alkaloids have been added to the growing list of ^{13}C n.m.r. data now available.¹⁸⁷ Cinchonidine can be converted into (–)-rubanol

¹⁸⁵ Y. Morita, S. Savaskan, K. A. Jaeggi, M. Hesse, U. Renner, and H. Schmid, *Helv. Chim. Acta*, 1975, **58**, 211.

¹⁸⁶ K. Bláha, Z. Koblicová, and J. Trojáněk, (a) *Tetrahedron Letters*, 1972, 2763; (b) *Coll. Czech. Chem. Comm.*, 1974, **39**, 2258.

¹⁸⁷ C. G. Moreland, A. Philip, and F. I. Carroll, *J. Org. Chem.*, 1974, **39**, 2413.

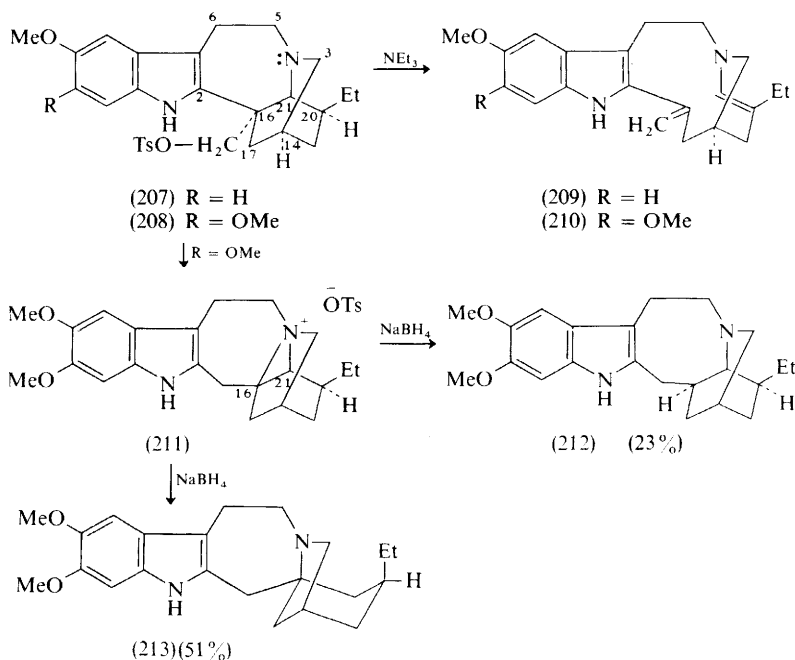

Scheme 36

by oxidation to cinchotenidine, followed by a Hunsdiecker reaction, and hydrogenolytic removal of the bromine; cinchonine similarly gives a diastereoisomeric (+)-rubanol.¹⁸⁸ Elimination of hydrogen chloride from diastereoisomeric chlorodihydroepiquinidines gives apoepiquinidine, isoepiquinidine, and an unidentified base.¹⁸⁹

After the almost frenetic activity in camptothecin synthesis during the last two years there is little to report during the year under review. Full details of the synthesis by Tang and Rapoport^{190a} are now available.^{190b}

Oxidative fission of the indole 2,7-double bond in the 18,19-dihydro-tetra-*O*-acetate of strictosamide (216a) proceeds faster¹⁹¹ than the analogous fission of its C-3 epimer, derived from (216b). Since cyclization of the product affords a compound (217) having the camptothecin ring system this result may be significant in relation to camptothecin biosynthesis which is known¹⁹² to involve (216a) rather than the 3 β -isomer (216b) or vincoside, which also contains β -hydrogen at C-3 (Scheme 38).

¹⁸⁸ A. Lempka, *Pr. Zakresu Towarozn. Chem., Wyzsza Szk. Ekon. Poznaniu, Zesz. Nauk. Ser. I*, 1974, **53**, 145, 151 (*Chem. Abs.*, 1974, **81**, 120 841; 1975, **82**, 43 630).

¹⁸⁹ J. Suszko and J. Thiel, *Roczniki Chem.*, 1974, **48**, 1281 (*Chem. Abs.*, 1975, **82**, 43 632).

¹⁹⁰ (a) C. Tang and H. Rapoport, *J. Amer. Chem. Soc.*, 1972, **94**, 8615; (b) C. S. F. Tang, C. J. Morrow, and H. Rapoport, *ibid.*, 1975, **97**, 159.

¹⁹¹ C. R. Hutchinson, G. J. O'Loughlin, R. T. Brown, and S. B. Fraser, *J.C.S. Chem. Comm.*, 1974, 928.

¹⁹² C. R. Hutchinson, A. H. Heckendorf, P. E. Daddona, E. Hagaman, and E. Wenkert, *J. Amer. Chem. Soc.*, 1974, **96** 5609.

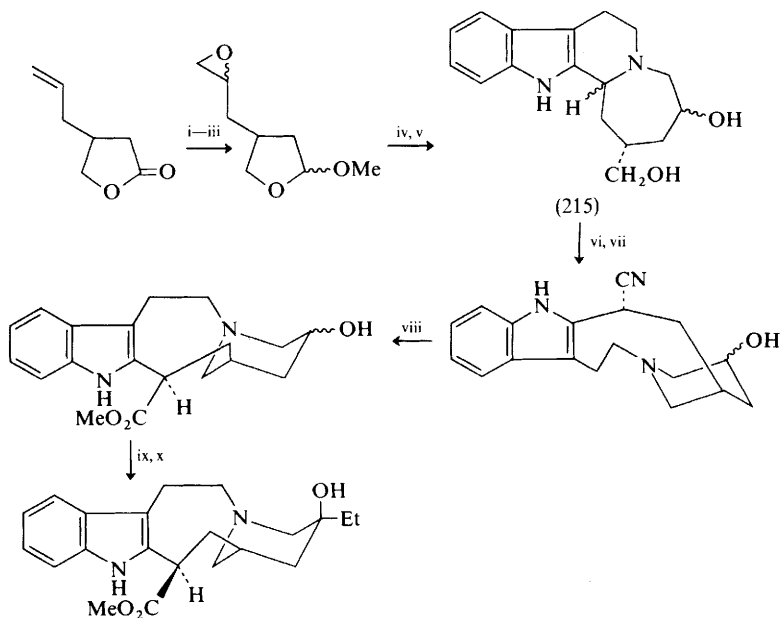

Reagents: i, Bu_2AlH ; ii, methanolysis; iii, epoxidation; iv, tryptamine, MeOH , Δ ; v, AcOH ; vi, tosylation; vii, NaCN , DMF , 150°C ; viii, MeOH-HCl ; ix, *N*-chlorosuccinimide, $\text{Me}_2\text{S-C}_6\text{H}_3\text{Me-CF}_3\text{CO}_2\text{H}$; x, LiEt , -90°C .

Scheme 37

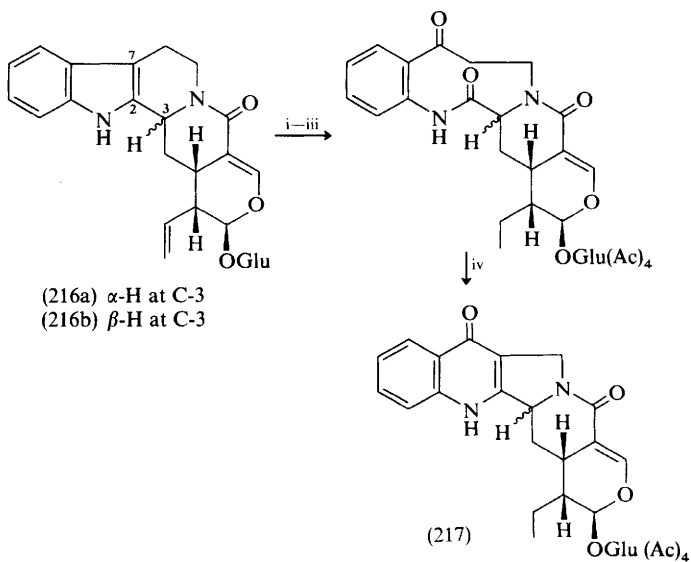

Reagents: i, hydrogenation; ii, acetylation; iii, NaIO_4 ; iv, NEt_3 - EtOH .

Scheme 38

The first total synthesis¹⁹³ of (\pm)-mappicine (218) (Scheme 39), a minor alkaloid of *Mappia foetida*, uses as starting material the potential camptothecin intermediate (219), into which the pyridone methyl group was introduced by means of diazomethane, the easily separated by-product was the cyclopropane derivative (220). The remaining steps in the synthesis are unexceptional.

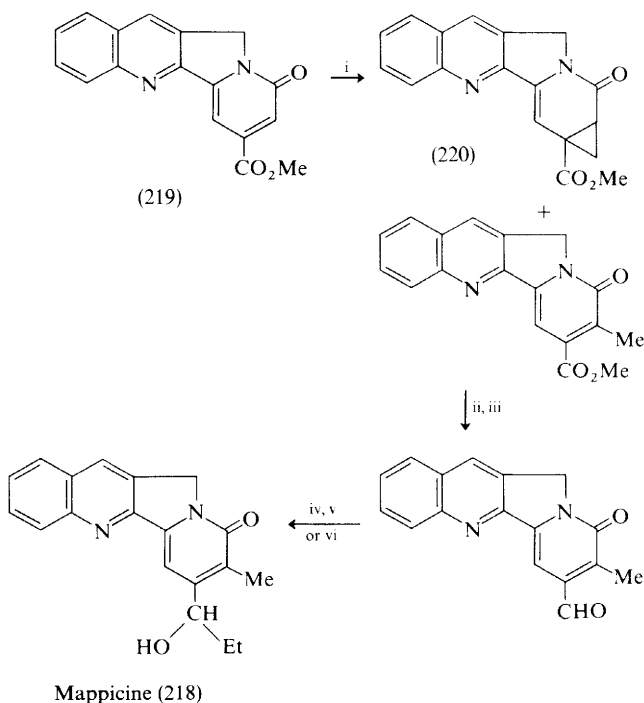

Reagents: i, CH_2N_2 (excess), CHCl_3 -MeOH, r.t., 24 h; ii, LiBH_4 , diglyme, 100 °C; iii, DMSO- Ac_2O , 90 °C, 4 h; iv, MeCHN_2 , CHCl_3 - Et_2O ; v, NaBH_4 , MeOH; vi, EtMgBr , Et_2O -THF.

Scheme 39

5 Bisindole Alkaloids

Recently reported isolations of known alkaloids includes voacamine from *Gabunia eglandulosa*^{124b} and (together with conodurine) from *Peschiera laeta*,⁶⁹ (-)-decarbomethoxyvoacamine from *Pandaca speciosa*,¹⁸² vobtusine from the fruits,¹²³ and vobtusine, deoxyvobtusine and vobtusine lactone from the leaves, of *Voacanga grandifolia* (Miq.) Rolfe,¹⁹⁴ and deacetoxyvinblastine from *Catharanthus roseus*.¹⁹⁵ Tetrahydrosecamine, tetrahydropresecamine, and decarbomethoxytetrahydrosecamine have been found in the roots of *Amsonia tabernaemontana*.¹⁹⁶

¹⁹³ T. Kametani, H. Takeda, H. Nemoto, and K. Fukumoto, *Heterocycles*, 1975, **3**, 167.

¹⁹⁴ P. L. Majumder, T. K. Chanda, and B. N. Dinda, *Phytochemistry*, 1974, **13**, 1261.

¹⁹⁵ N. Neuss, A. J. Barnes, and L. L. Huckstep, *Experientia*, 1975, **31**, 18.

¹⁹⁶ B. Zsardon, M. Szilasi, J. Tamás, and P. Kaposi, *Phytochemistry*, 1975, **14**, 1438.

A bisindole alkaloid isolated by the French group from *Gabunia eglandulosa*¹⁸¹ appears not to be voacamine, and may be new; ten others, so far of unspecified structure, have been extracted from *Muntafara sessilifolia*,¹³² and a group of four, from *Pandaca caducifolia*,¹³¹ belong to a new structural type, but their structures have not yet been elucidated in detail.

Of the new bases whose structures have been clarified quimbeline (221), from *Voacanga chalongiana*,¹⁹⁷ differs from vobtusine only in having an ether bridge between the C-2' hydroxyl group and C-22'; the structure (221) was deduced almost entirely from ¹³C n.m.r. and mass spectral comparison with vobtusine, and confirmed by hydrogenolytic fission of the oxetan ring, which afforded vobtusine.

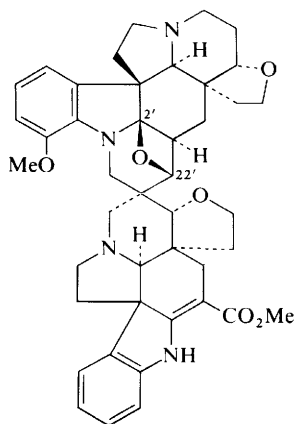

Quimbeline (221)

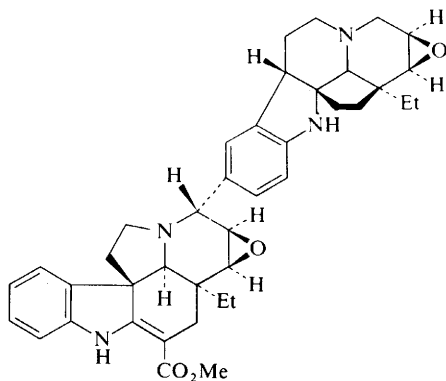

Cryophylline (222)

Cryophylline (222), from *Crioceras dipladeniiflorus*,¹⁶¹ also contains a tabersonine-derived component, and has the novel feature of two epoxide functions in the molecule. Detailed comparison, particularly of the ¹³C n.m.r. spectra, of cryophylline with the monomers andrangine (157) (which occurs in the same plant) and hazuntinine (223), enabled structure (222) to be elucidated.

Catharine, first isolated in 1961 from *Catharanthus roseus*,^{198a} was subsequently stated, correctly, to possess an intact vindoline component.^{198b} The second component has only recently been elucidated;¹⁹⁹ it contains an unusual enamide function, presumably derived from the oxidative fission of the piperidine ring in a velbanamine derivative. Catharine is thus closely related to vinblastine, and its complete structure, elucidated by the X-ray method, is (224).

The third alkaloid of *Capuronetta elegans*, capuvosine (225), is a bisindole alkaloid of new type in which a vobasine unit is attached to one of dihydrocleavamine type.¹⁸³ Indeed, fission of capuvosine by means of hydrochloric acid results in the formation

¹⁹⁷ E. Bombardelli, A. Bonati, B. Danieli, B. Gabetta, E. M. Martinelli, and G. Mustich, *Experientia*, 1975, **31**, 139.

¹⁹⁸ (a) G. H. Svoboda, M. Gorman, N. Neuss, and A. J. Barnes, *J. Pharm. Sci.*, 1961, **50**, 409; (b) D. J. Abraham, N. R. Farnsworth, R. N. Blomster, and R. E. Rhodes, *ibid.*, 1967, **56**, 401.

¹⁹⁹ P. Rasoanaivo, A. Ahond, J. P. Cosson, N. Langlois, P. Potier, J. Guilhem, A. Ducruix, C. Riche, and C. Pascard, *Compt. rend.*, 1974, **279**, C, 75.

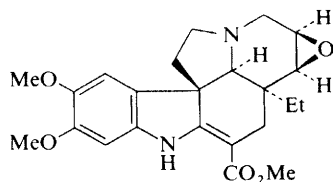

Hazuntinine (223)

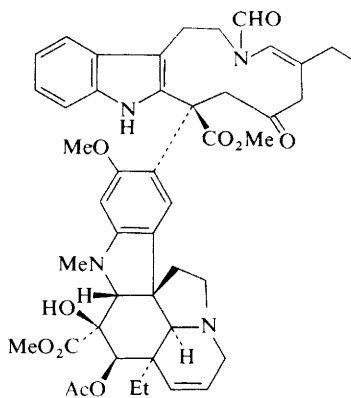

Catharine (224)

of (+)-capurinine (201), but the second fission product could not be identified. However, a partial synthesis of capuvosine (225) was realized by the condensation of vobasinol (226) with capurinine acetate in the presence of methanolic HCl, the immediate product from which was capuvosine acetate (227). The configuration at

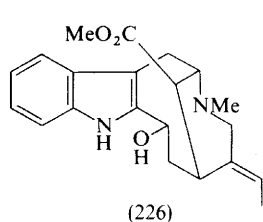

(226)

+
Capurinine acetate

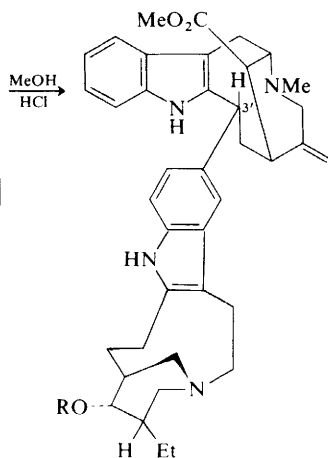

Capuvosine (225) R = H
Capuvosine acetate (227) R = Ac

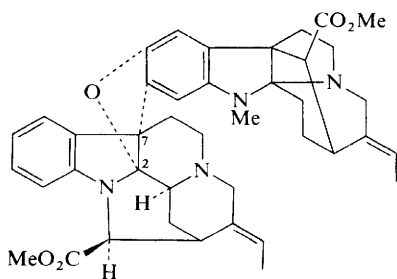

Pleiocorine (228)

C-3' and the position of attachment of the vobasinol unit to the capuronic component remain to be unequivocally established.¹⁸³

A most ingenious application of 240 MHz ¹³C n.m.r. spectroscopy has enabled the structure of pleiocorine (228), a bisindole alkaloid of New Caledonian *Alstonia deplanchei* van Heurck et Muell. Arg., to be established.²⁰⁰ It was first observed that the ¹H n.m.r. spectrum of pleiocorine contained signals reminiscent of the 2,7-dihydropleiocarpamine component of villalstonine. It thus became necessary to make a rigorous assignment of all the carbon atoms in 2,7-dihydropleiocarpamine. This was achieved indirectly by identifying the signals owing to the macroline unit in villalstonine (macroline + 2,7-dihydropleiocarpamine type) and macralstonidine (macroline + sarpagine type), and confirming the assignments by comparing the spectra of macralstonidine and sarpagine. By subtraction of the macroline signals from the villalstonine spectrum the assignments for a 2,7-dihydropleiocarpamine component could be deduced, and these were then clearly identified in the spectrum of pleiocorine. Analysis of the remaining signals indicated that the second component was probably related to vincorine (112), which had also been isolated from *A. deplanchei*. The structure finally deduced²⁰⁰ for pleiocorine is thus (228), in which the only remaining uncertainty concerns the configuration at C-2 and C-7.

Gardmultine (Alkaloid E), first isolated in 1970 from *Gardneria multiflora*,^{201a} is composed of two typical monomeric *Gardneria* components, and thus has a structure (229) peculiar to alkaloids from this particular source.^{201b} Its u.v. spectrum is a summation of trimethoxyoxindole and corresponding indoline chromophores, but becomes oxindolic on acid hydrolysis, by hydrolysis of the amide acetal function. The fact that no isomerization occurs in acid solution (contrast the behaviour of oxindole analogues of the heteroyohimbine alkaloids) suggests that both components of gardmultine have the bridged-ring structure present in the monomeric *Gardneria* alkaloids. The presence of six aromatic methoxy-groups, an ethylidene group, and a methoxyethylidene group, suggests that the component bases are gardneramine (122) and chitosenine (125). The structure (229) thus deduced is supported by its conversion when heated with formic acid, followed by ethanolic potassium hydroxide, into the diol (230), from which gardmultine can be resynthesized by treatment of its monomesylate with potassium t-butoxide (Scheme 40).^{201b}

X-Ray crystal structure determination^{202a} of a bisindole derivative (231) synthesized earlier^{202b} from 16-carbomethoxy-20 α -H dihydrocleavamine and vindoline has revealed that it has the unnatural configuration at C-16', and is therefore 16'-epi-20'-deoxy-20'-epivinblastine (231). Similarly the product of condensation of 16-carbomethoxycleavamine with vindoline is the analogous 16'-epi-15',20'-dehydrovinblastine (232), since it gives (231) on hydrogenation, and it is almost certainly identical with Atta-ur-Rahman's $\Delta^{15,20}$ -anhydrovinblastine.^{202c} A third compound (233) in this series, formed by condensation of 20 α -H dihydrocleavamine with vindoline, has the same configuration at C-16', in spite of the fact that here C-16' is epimerizable in the acid medium used for the condensation.^{202a}

²⁰⁰ B. C. Das, J. P. Cosson, G. Lukacs, and P. Potier, *Tetrahedron Letters*, 1974, 4299.

²⁰¹ (a) J. Haginiwa, S. Sakai, A. Kubo, K. Takahashi, and M. Taguchi, *Yakugaku Zasshi*, 1970, **90**, 219; (b) S. Sakai, N. Aimi, K. Yamaguchi, E. Yamanaka, and J. Haginiwa, *Tetrahedron Letters*, 1975, 719.

²⁰² J. P. Kutney, J. Cook, K. Fuji, A. M. Treasurywala, J. Clardy, J. Fayos, and H. Wright, *Heterocycles*, 1975, **3**, 205; (b) J. P. Kutney, J. Beck, F. Bylsma, and W. J. Cretney, *J. Amer. Chem. Soc.*, 1968, **90**, 4504; (c) Atta-ur-Rahman, *Pakistan J. Sci. Ind. Res.*, 1971, **14**, 487.

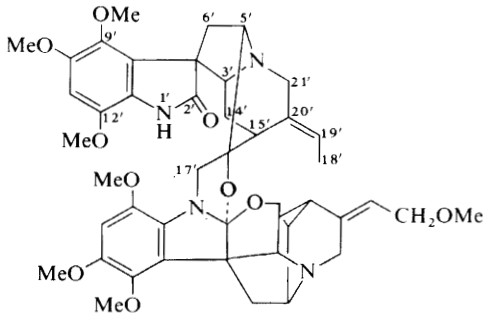

Gardmultine (229)

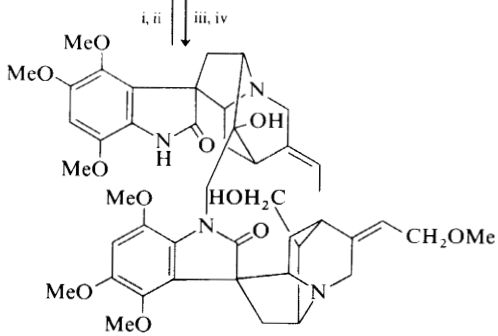

(230)

Reagents: i, $\text{MeSO}_2\text{Cl-py}$; ii, Bu^tOK , BuOH ; iii, HCO_2H , Δ ; iv, EtOH , KOH .

Scheme 40

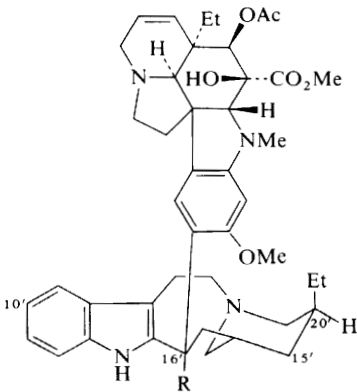

(231) $\text{R} = \text{CO}_2\text{Me}$

(232) $\text{R} = \text{CO}_2\text{Me}$, $\Delta^{15',20'}$

(233) $\text{R} = \text{H}$

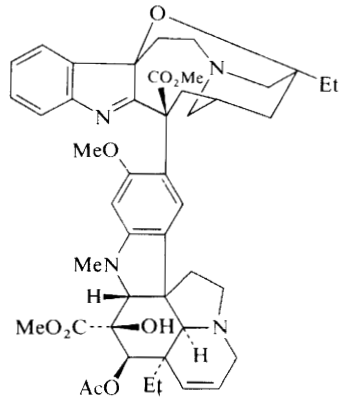

(234)

10'-Hydroxyvinblastine and an internal ether (234), formed from vinblastine hydroxyindolenine, are the products of the microbiological action of *Streptomyces albogriseolus* on vinblastine.²⁰³

Details have been published^{204a} of the synthesis by Winterfeldt's group of roxburghine D, reported earlier in brief,^{204b} as have details^{205a} of the structure elucidation^{205b} of the indolic pigment, trichotomine. Trichotomine G₁, from the same source, is simply an *ind-N-β-D-glucopyranosyl* derivative (235) of trichotomine, and is the first such structure encountered among natural compounds.^{205a}

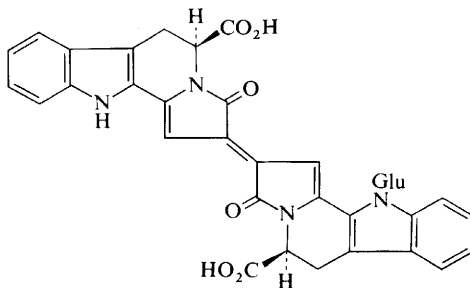

Trichotomine G₁ (235)

²⁰³ N. Neuss, G. E. Mallett, D. R. Brannon, J. A. Mabe, H. R. Horton, and L. L. Huckstep, *Helv. Chim. Acta*, 1974, **57**, 1886.

²⁰⁴ (a) G. Benz, H. Riesner, and E. Winterfeldt, *Chem. Ber.*, 1975, **108**, 248; (b) H. Riesner and E. Winterfeldt, *J.C.S. Chem. Comm.*, 1972, 786.

²⁰⁵ (a) S. Iwadare, Y. Shizuri, K. Sasaki, and Y. Hirata, *Tetrahedron*, 1974, **30**, 4105; (b) S. Iwadare, Y. Shizuri, K. Sasaki, and Y. Hirata, *Tetrahedron Letters*, 1974, 1051; S. Iwadare, Y. Shizuri, K. Yamada, and Y. Hirata, *ibid.*, p. 1177.

The synthesis of (\pm)-serratinine, a formidable objective with its six chiral centres and two adjacent quaternary carbons, highlights the period under review.¹ The starting material for the synthesis is the benzoquinone (1), which was transformed into the dialdehyde (2) in seven steps² as indicated in Scheme 1. Cyclization of the

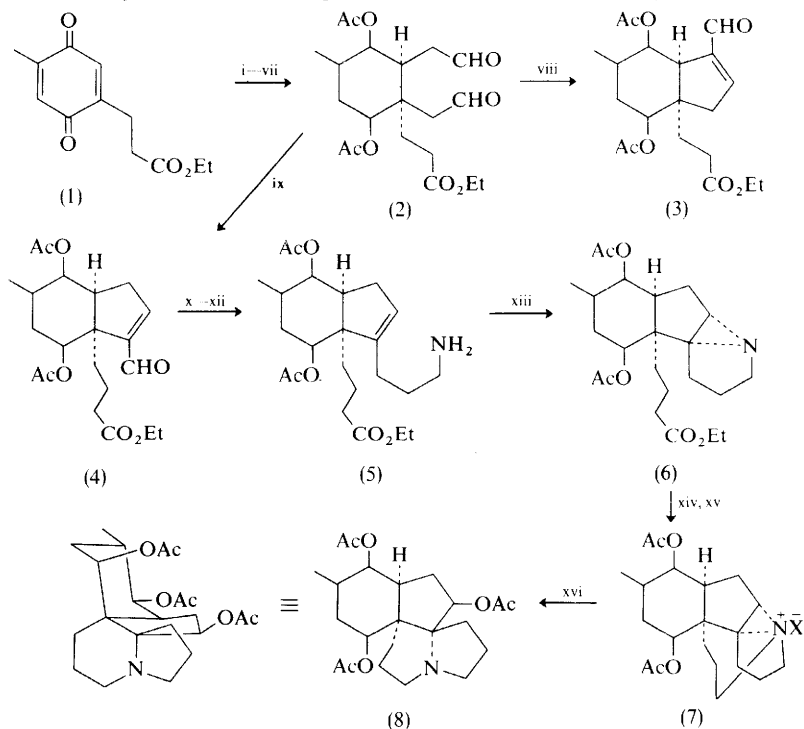

Reagents: i, $\text{CH}_2=\text{CHCH}=\text{CH}_2$; ii, Zn, HOAc; iii, NaBH_4 , EtOH; iv, Ac_2O , pyridine; v, $\text{OsO}_4\text{-NaClO}_3$, aq. THF; vi, $\text{H}_2\text{-Pt}$, EtOH; vii, HIO_4 , aq. dioxan; viii, basic alumina or piperidinium acetate, C_6H_6 ; ix, pyrrolidine, HOAc, MeOH; x, $(\text{EtO})_2\text{P}(\text{O})\text{CH}_2\text{CN}$; xi, H_2 , $(\text{Ph}_3\text{P})_3\text{RhCl}$; xii, $\text{NaBH}_4\text{-CoCl}_2$; xiii, *N*-chlorosuccinimide, Cu_2Cl_2 ; xiv, LiBH_4 ; xv, toluene-*p*-sulphonyl chloride, pyridine; xvi, KOAc, EtOH.

Scheme 1

¹ T. Harayama, M. Ohtani, M. Oki, and Y. Inubushi, *J.C.S. Chem. Comm.*, 1974, 827.

² T. Harayama, M. Ohtani, M. Oki, and Y. Inubushi, *Chem. and Pharm. Bull. (Japan)*, 1973, **21**, 1061.

dialdehyde (2), catalysed by basic alumina or *via* the enamine (piperidinium acetate in benzene), occurred in the undesired direction to give exclusively the unsaturated aldehyde (3). Reasoning that this mode of cyclization involves addition of the less hindered enolate or enamine to the more hindered aldehyde function, conditions were sought which would favour cyclization of the initially formed immonium salt prior to tautomerization to the enamine. Treatment of (2) with an excess of pyrrolidine and acetic acid in anhydrous methanol indeed afforded predominantly the desired unsaturated aldehyde (4). The aldehyde (4) was transformed into the amine (5) in three steps, setting the stage for the very elegant construction of the heterocyclic rings. Intramolecular cycloaddition of the nitrene, generated from amine (5) *via* the chloro-amine, gave the aziridine (6). The ethoxycarbonyl group in (6) was selectively reduced to the primary alcohol, which on tosylation underwent cyclization to the aziridinium salt (7). The highly strained aziridinium ring in (7) was opened upon treatment with potassium acetate in ethanol to give the triacetate (8), containing the complete ring system of serratinine. Saponification of (8) followed by Jones' oxidation afforded the corresponding triketone, which on reduction with NaBH_4 gave approximately equal amounts of racemic serratinine (9) and (\pm)-8-*epi*-serratinine.² The selective reduction of the six-membered ketones is commented upon later.

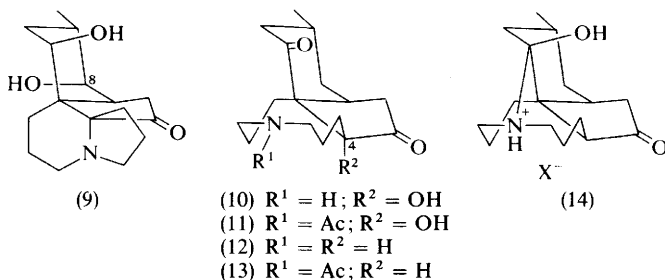

Alopecuridine, an alkaloid from *Lycopodium alopecuroides* L., has been shown to be 4 α -hydroxyfawcettimine (10).³ The structure was established by X-ray crystallographic analysis of *N*-acetylolopecuridine (11), and by calcium-ammonia reduction to fawcettimine (12). Since the absolute configuration of fawcettimine is known through correlation with serratinine,⁴ structure (10) represents the absolute stereochemistry of alopecuridine. The similarity of the c.d. spectra of *N*-acetylolopecuridine (11) and *N*-acetylfawcettimine (13) suggests that they have the same configuration at C-4, a feature of the fawcettimine (12) structure which had not previously been determined. Infrared evidence indicates that alopecuridine salts are of the carbinolamine form (14).³ It has been observed⁵ that treatment of *N*-acetylfawcettimine (13) with NaBH_4 leads to reduction of the cyclohexanone carbonyl only. Similar selectivity was noted in the serratinine synthesis discussed

³ W. A. Ayer, B. Altenkirk, and Y. Fukazawa, *Tetrahedron*, 1974, **30**, 4213.

⁴ K. Nishio, T. Fujiwara, K. Tomita, H. Ishii, T. Inubushi, and T. Harayama, *Tetrahedron Letters*, 1969, 861.

⁵ R. H. Burnell, C. G. Chin, B. S. Mootoo, and D. R. Taylor, *Canad. J. Chem.*, 1963, **41**, 3091.

above, and was also observed in the case of lycoflexine (15).⁶ It is tempting to speculate that this selectivity may be due to the formation of a metal complex of the internal hemiketal [(16), in the case of *N*-acetylfawcettimine].

New structural types continue to appear among this group of alkaloids. Paniculatine, an alkaloid of *L. paniculatum*, has been shown by X-ray methods to have structure (17), with a unique C-3 to C-10 bond.⁷

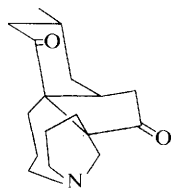

(15)

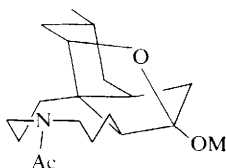

(16)

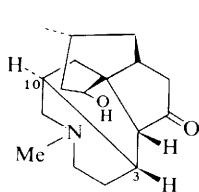

(17)

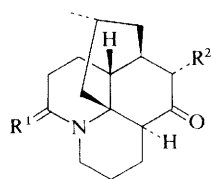
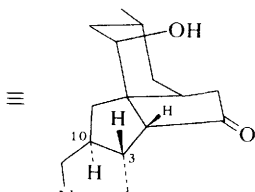

- (18) R¹ = H₂; R² = H
 (19) R¹ = O; R² = OH
 (20) R¹ = O; R² = Cl
 (21) R¹ = O; R² = H

Known alkaloids reported from new sources include lycopodine (18), fawcettiine, *O*-acetylfawcettiine, *O*-acetyldihydrolycopodine,^{8,9} and fawcettidine⁹ from *L. thyoides*. The first four mentioned and clavonine are also present in *L. contiguum*.^{8,9} Lycopodine, dihydrolycopodine, and *O*-acetyldihydrolycopodine were isolated from *L. paniculatum*.⁷ 6- α -Hydroxylycopodine lactam (19) has been isolated from *L. clavatum* var. *inflexum*.¹⁰ Treatment of (19) with SOCl₂-CH₂Cl₂ gave the chloro-compound (20), which was transformed into the known lycopodine lactam (21) by treatment with LiI and BF₃. The configuration of the hydroxy-group was determined by spectroscopic methods.¹⁰

An interesting paper discussing the distribution of alkaloids in the genus *Lycopodium* has appeared.⁹ Some taxonomists, notably Rothmaler,¹¹ argue that the Order Lycopodiales, which has been considered to contain only one Family,

⁶ W. A. Ayer, Y. Fukazawa, P. P. Singer, and B. Altenkirk, *Tetrahedron Letters*, 1973, 5045.

⁷ M. Castille, G. Morales, L. A. Loyola, I. Singh, C. Calvo, H. L. Holland, and D. B. MacLean, *Canad. J. Chem.*, 1975, **53**, 2513.

⁸ W. A. Ayer and S. Dikko, *Phytochemistry*, 1974, **13**, 653.

⁹ J. C. Braekman, L. Nyembo, P. Bourdoux, N. Kahindo, and C. Hootele, *Phytochemistry*, 1974, **13**, 2519.

¹⁰ P. P. Singer, Ph.D. Thesis, University of Alberta, 1975, 35.

¹¹ W. Rothmaler, *Fedde's Repertorium*, 1951, **54**, 256.

Lycopodiaceae, with two genera (*Lycopodium* and *Phylloglossum*) should be reclassified to include two families, Urostachyaceae (genus *Huperia*) and *Lycopodiaceae* (genera *Lycopodium*, *Lepidotus*, *Diphassium*, and *Phylloglossum*). The present work⁹ provides support for the Rothmaler classification and suggests that a more detailed study, using the alkaloids as markers, may be of taxonomical value. Interestingly, a sample of *L. clavatum* harvested in 1882 showed essentially the same alkaloid content as a sample harvested just prior to extraction.⁹

The absolute configuration of lycopodine (18) has been confirmed by an X-ray crystallographic study of the hydrochloride.¹² The ¹³C n.m.r. spectra of several alkaloids of the lycopodine (19) and lycodine (22) type have been studied and the resonances assigned.¹³ Of particular interest is the finding that the *N*-methyl group in the obscurines and *N*-methyl-lycodine (22) prefers the axial configuration.

The intriguing question as to the precise mode of biosynthesis of lycopodine remains in part unanswered. The latest developments and a summary of previous results are the subject of a recent paper.¹⁴

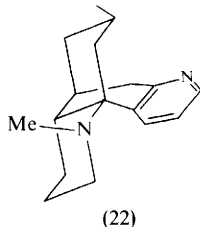

¹² D. Rogers, A. Quick, and Mazhar-Ul-Haque, *J.C.S. Chem. Comm.*, 1974, 522.

¹³ T. T. Nakashima, P. P. Singer, L. M. Browne, and W. A. Ayer, *Canad. J. Chem.*, 1975, **53**, 1936.

¹⁴ W. D. Marshall, T. T. Nguyen, D. B. MacLean, and I. D. Spenser, *Canad. J. Chem.*, 1975, **53**, 41.

1 Introduction

The emphasis in C_{19} and C_{20} diterpenoid alkaloid research as evidenced by published accounts during the past year has shifted from synthesis¹ to structure determination. Of particular interest are the reports of the isolation of two new C_{19} bases, acomonine and iliensine, having no C-1 oxygen function. The structures of delphisine and deoxydelcorine have been determined, and revisions of the structures earlier proposed for neoline, chasmanine, homochasmanine, and excelsine have appeared. The numbering systems for the lycotoline, atisine, and veatchine skeletons are indicated in structures (A), (B), and (C), respectively.

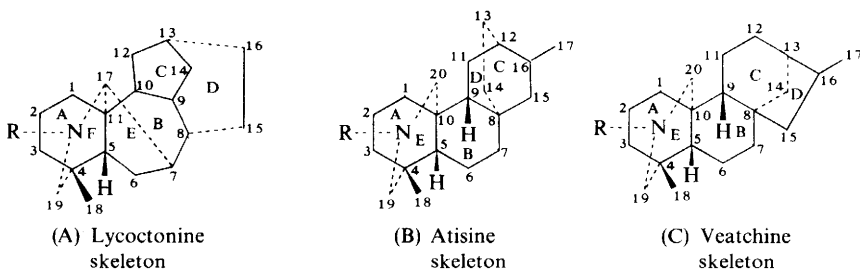

The chemistry of the *Daphniphyllum* alkaloids has focused on the biogenetic aspects of their occurrence. The search for proposed biosynthetic intermediates among the minor alkaloids of these plants has resulted in the isolation and structure elucidation of five new bases. Accomplishments have included interconversions of the *Daphniphyllum* alkaloids by bond formation or fission. The compounds isolated thus far have been divided into five structural types and are reviewed as diterpenoids

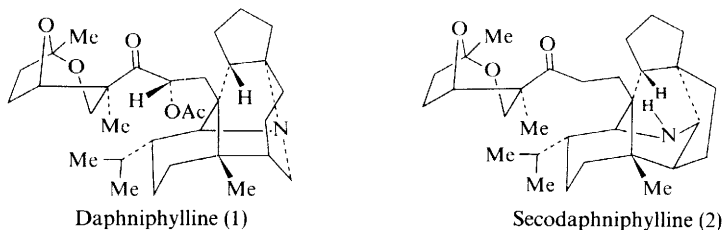

¹ S. W. Pelletier and S. W. Page, in 'The Alkaloids', ed. J. E. Saxton (Specialist Periodical Reports). The Chemical Society, London, 1975, Vol. 5, Ch. 13.

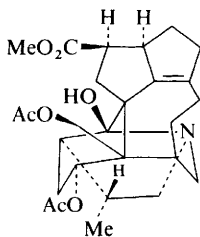

Yuzurimine (3)

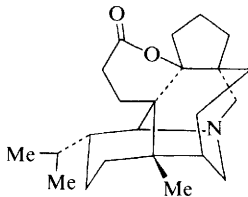

Daphnilactone-A (4)

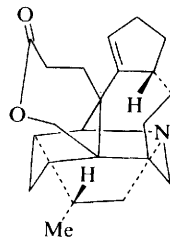

Daphnilactone-B (5)

based on the N-heterocyclic carbon skeleton. These five types are represented by daphniphylline (1), secodaphniphylline (2), yuzurimine (3), daphnilactone-A (4), and daphnilactone-B (5).²

2 C₁₉ Diterpenoid Alkaloids

Acomonine.—Soviet researchers have reported the isolation of a new lycotoxine-type alkaloid, acomonine (6), which has no oxygen functionality at C-1.³ This base, C₂₅H₄₁NO₇, m.p. 208—210 °C, was isolated from the roots of *Aconitum monticola*, co-occurring with songorine (7) and norsongorine (8).

From spectral data, acomonine was shown to contain an *N*-ethyl, four methoxy-, and three hydroxy-groups. Acetylation with acetic anhydride in pyridine yielded a monoacetyl derivative. Treatment with toluene-*p*-sulphonyl chloride afforded anhydroacomonine, which was hydrogenated with Adams' catalyst to desoxyacomonine. Periodate oxidation of anhydroacomonine gave secodesmethanol-anhydroacomonine. The spectral data for this compound indicated the presence of an $\alpha\beta$ -unsaturated oxocyclohexyl group and an oxocyclopentyl group. These data account for an α -glycol system at C-7 and C-8 and a methoxy function at C-16.

On treatment of acomonine with potassium permanganate in aqueous acetone, an anhydro-oxy-derivative resulted. This internal carbinol amine ether was converted into the original base by sodium borohydride reduction. Permanganate oxidation of desoxyacomonine gave an oxo-derivative containing a γ -lactam. On the basis of this chemical and additional spectral data, the secondary hydroxy-group was located at C-3.

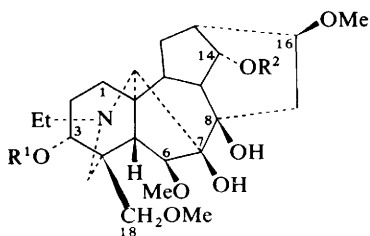
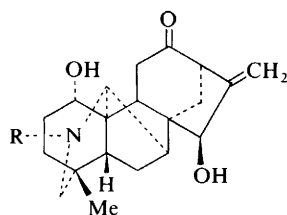
Acomonine (6) R¹ = H; R² = Me(9) R¹ = R² = MeIliensine (10) R¹ = R² = H

Songorine (7) R = Et

Norsongorine (8) R = H

² M. Toda, H. Niwa, H. Irikawa, Y. Hirata, and S. Yamamura, *Tetrahedron*, 1974, **30**, 2683.

³ V. E. Nezhevenko, M. S. Yunusov, and S. Yu. Yunusov, *Khim. prirod. Soedinenii*, 1974, **10**, 409.

From mass spectral and ^1H n.m.r. data, methoxy-groups were located at C-14 and C-18, with no oxygen function at C-1. The remaining methoxy-group was not assigned in the original paper.³ However, it was located at C-6, without additional evidence to support this assignment, in the subsequent report on the structure of iliensine.⁴

Iliensine.—Yunusov, Nezhevenko, and Yunusov have reported a second lycoctonine-type alkaloid which has no C-1 oxygen substituent.⁴ Iliensine, $\text{C}_{24}\text{H}_{39}\text{NO}_7$, m.p. 201—203 °C, was isolated from *Delphinium biernatum*. I.r., ^1H n.m.r., and mass spectral data indicated that this new base is a desmethylacononine derivative. Methylation of iliensine with methyl iodide-sodium hydride afforded an *OO*-dimethyl derivative, which was identical with *O*-methylacononine (9). Chemical and spectral data support the location of secondary hydroxy-groups at C-3 and C-14. Iliensine was accordingly assigned structure (10).

Delphisine.—A new alkaloid, delphisine, $\text{C}_{28}\text{H}_{43}\text{NO}_8$, m.p. 121—122 °C, has been isolated from the seeds of *Delphinium staphisagria*,⁵ by a combination of pH extractions and chromatographic techniques. Chemical and spectral studies indicated it to be a member of the aconitine-type alkaloids.

An X-ray crystallographic study of delphisine as the hydrochloride salt using direct phasing methods determined its structure to be (11), with $R = 0.040$, based on 2889 reflections.⁶ The indicated absolute configuration was determined by Hamilton's method and confirmed by examination of sensitive Friedel pairs. This structure is consistent with all spectral and chemical data. In delphisine hydrochloride, ring A exists in a boat conformation, stabilized by an intramolecular $\text{N—H}\cdots\text{O}$ hydrogen bond. Ring D is in a boat conformation, flattened at C-15.

Neoline, Chasmanine, and Homochasmanine.—These alkaloids have been chemically correlated with delphisine.⁷ Wiesner and co-workers⁸ had originally assigned structure (12) to neoline. However, in a subsequent correlation with chasmanine, which had been assigned structure (13) on the basis of a reported correlation with browniine,⁹ Marion and co-workers assigned structure (14) to neoline.^{10a} New work has demonstrated that neoline has structure (12) and that the structures of chasmanine and homochasmanine must now be revised to (18) and (19), respectively.

Cornforth oxidation of delphisine gave 1-ketodelphisine (15), which afforded (16) on alkaline hydrolysis. The reverse procedure gave a mixture of (16) and (17). Reduction of (17) with one equivalent of sodium borohydride proceeded stereospecifically to (16). Reduction of (16) with borohydride gave a 1 : 2 mixture of the triols (12) and (14), respectively. These epimers were separable by preparative t.l.c.

⁴ M. S. Yunusov, V. E. Nezhevenko, and S. Yu. Yunusov, *Khim. prirod. Soedinenii*, 1975, **11**, 107.

⁵ W. A. Jacobs and L. C. Craig, *J. Biol. Chem.*, 1941, **141**, 67.

⁶ S. W. Pelletier, W. H. De Camp, S. D. Lajšič, Z. Djarmati, and A. H. Kapadi, *J. Amer. Chem. Soc.*, 1974, **96**, 7815.

⁷ S. W. Pelletier, Z. Djarmati, and S. Lajšič, *J. Amer. Chem. Soc.*, 1974, **96**, 7817.

⁸ K. Wiesner, H. W. Brewer, D. L. Simmons, D. R. Babin, F. Bickelhaupt, J. Kallos, and T. Bogri, *Tetrahedron Letters*, 1960, 17.

⁹ O. E. Edwards, L. Fonzes, and L. Marion, *Canad. J. Chem.*, 1966, **44**, 583.

¹⁰ (a) L. Marion, J. P. Boca, and J. Kallos, *Tetrahedron Suppl.*, 1966, **8**, Pt. 1, p. 101; (b) O. Achmatowicz, jun. and L. Marion, *Canad. J. Chem.*, 1965, **43**, 1093.

On acetylation with acetic anhydride–toluene-*p*-sulphonic acid, both compounds formed triacetate derivatives. The triacetate from (12) was identical with delphisine 1 α -monoacetate. Epimer (12) was shown to be identical with natural neoline, demonstrating that Wiesner's original structural assignment⁸ is correct.

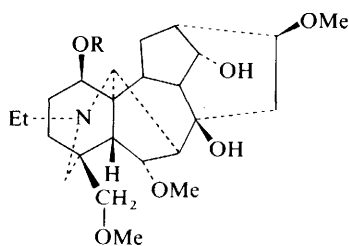
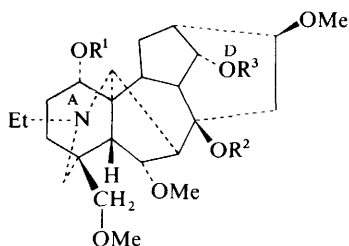

Delphisine (11) $R^1 = H; R^2 = R^3 = Ac$
 Neoline (12) $R^1 = R^2 = R^3 = H$
 Chasmanine (18) $R^1 = Me; R^2 = R^3 = H$
 Homochasmanine (19) $R^1 = R^2 = Me; R^3 = H$

(13) $R = Me$
 (14) $R = H$

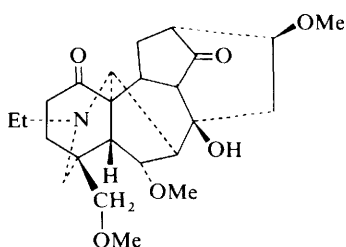
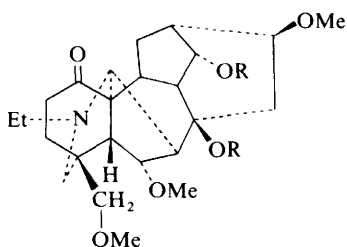

(15) $R = Ac$
 (16) $R = H$

(17)

Since chasmanine and neoline form identical derivatives on methylation with methyl iodide–sodium hydride,^{10a} chasmanine (18) must also contain a 1 α -substituent, and it is therefore clear that the reported correlation of chasmanine with browniine⁹ must be in error. The previous conversion of chasmanine diacetate into homochasmanine^{10b} permits assignment of structure (19) to the latter. A ¹³C n.m.r. study of chasmanine (18), delphonine (20), neoline (12), and delphisine (11) supports the assignment of the 1 α -groups in structures (11), (12), (18), and (19). In view of the X-ray crystallographic studies on delphisine,⁶ these correlations also define the absolute stereochemistries of these alkaloids.

Deoxydelcorine.—This alkaloid (21), C₂₆H₄₁NO₆, m.p. 93–95 °C, has been isolated from *Delphinium corumbosum*.¹¹ From ¹H n.m.r. data, evidence for the presence of an *N*-ethyl, a methylenedioxy-, and four methoxy-groups was obtained. The i.r. spectrum indicated the absence of a hydroxy-group.

Heating deoxydelcorine (21) with 10% sulphuric acid afforded demethylenedeoxydelcorine (22), which gave (23) on oxidation with periodic acid. These

¹¹ A. S. Narzullaev, M. S. Yunusov, and S. Yu. Yunusov, *Khim. prirod. Soedinenii*, 1974, **10**, 412.

structural assignments were based on u.v., i.r., ^1H n.m.r., and mass spectral data. From this information, the methylenedioxy system may be located at C-7 and C-8.

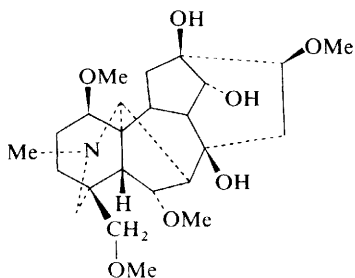

Delphonine (20)

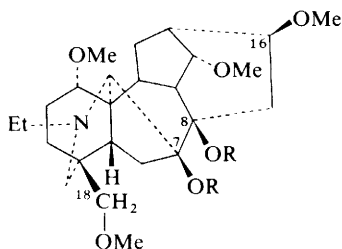
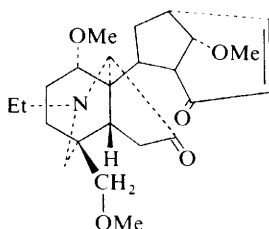
Deoxydelcorine (21) RR = CH₂
(22) R = H

(23)

The assignment of an α -methoxy-group at C-1 was based on the presence of the base peak at M-31 in the mass spectrum of (21). A methoxy-group was located at C-16 by the facile elimination of a molecule of methanol in the oxidation of (22) to (23). By analogy with other lycotoniine-type alkaloids, the remaining methoxy-group in deoxydelcorine was assigned to C-18.

Excelsine.—The structure and absolute configuration of excelsine (24), C₂₂H₃₃NO₆, m.p. 103–105 °C, have been determined by an X-ray crystallographic study of its hydriodide derivative.¹² On the basis of chemical and spectral data, structure (25) had previously been proposed for this alkaloid, which has been isolated from the roots of *Aconitum excelsum*.¹³

The structure was solved by the heavy-atom method, and the absolute configuration determined by examination of Friedel pairs. Rings C and E were shown to exist in envelope conformations, rings A and D were in boat conformations, and rings B and F exist in chair conformations.

In reviewing the earlier chemical and spectral data,¹³ the presence of the epoxide moiety explains several observations. Excelsine is reduced with Raney nickel in methanolic base to lapaconidine (26), but is inert to reduction with Adams' catalyst, sodium borohydride, or lithium aluminium hydride. Treatment of excelsine with boiling aqueous HCl gives an epimeric mixture of chlorohydrins. Hydrolysis with

¹² S. M. Nasirov, V. G. Andrianov, Yu. T. Struchkov, V. A. Tel'nov, M. S. Yunusov, and S. Yu. Yunusov, *Khim. prirod. Soedinenii*, 1974, **10**, 812.

¹³ V. A. Tel'nov, M. S. Yunusov, and S. Yu. Yunusov, *Khim. prirod. Soedinenii*, 1973, **9**, 129.

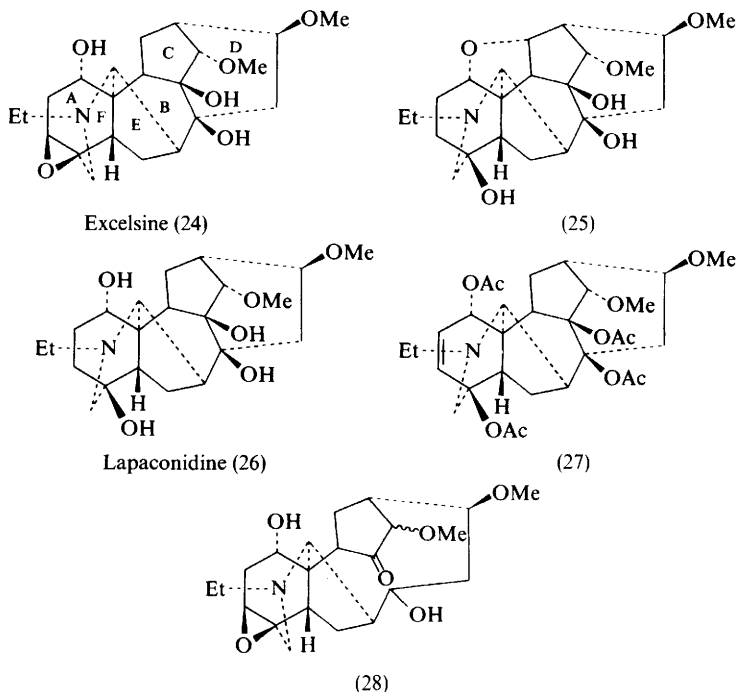

aqueous sulphuric acid followed by acetylation affords a tetra-acetate, which may be assigned structure (27) from the ^1H n.m.r. data. Oxidation of (24) with Kiliani reagent gives a compound $\text{C}_{22}\text{H}_{31}\text{NO}_6$, while periodic acid treatment gives a different derivative, $\text{C}_{22}\text{H}_{33}\text{NO}_6$. Both compounds contain oxocyclopentyl groups. By analogy with the chemistry of lapaconidine¹⁴ and lappaconine,¹⁵ structure (28) may be proposed for the compound prepared by Kiliani oxidation. However, the published data do not permit a definite assignment for the periodic acid product.

Veratroylpseudoaconine and Diacetylpseudoaconitine.—Purushothaman and Chandrasekharan examined the roots of *Aconitum ferox* for basic components.¹⁶ Czechoslovakian workers had earlier reported the isolation of seven alkaloids from this species.¹⁷ They identified pseudoaconitine (29), bikhaconitine (30), chasmaconitine (31), and indaconitine (32).

In addition to pseudoaconitine and bikhaconitine, the Indian group isolated veratroylpseudoaconine (33), m.p. 212 °C, and diacetylpseudoaconitine (34), m.p. 230 °C. The identities of pseudoaconitine and bikhaconitine were determined by spectral analyses and direct comparisons with authentic samples.

Alkaline hydrolysis of (33) or (34) yielded veratric acid, acetic acid, and pseudoaconine. On heating pseudoaconitine (29) with 0.1N- H_2SO_4 , (33) was

¹⁴ V. A. Tel'nov, N. S. Yunusov, Ya. V. Rashkes, and S. Yu. Yunusov, *Khim. prirod. Soedinenii*, 1971, **7**, 622.

¹⁵ N. M. Mollov, M. Tada, and L. Marion, *Tetrahedron Letters*, 1969, 2489.

¹⁶ K. Purushothaman and S. Chandrasekharan, *Phytochemistry*, 1974, **13**, 1975.

¹⁷ A. Klásek, V. Šimánek, and F. Šanlevý, *Lloydia*, 1972, **35**, 55.

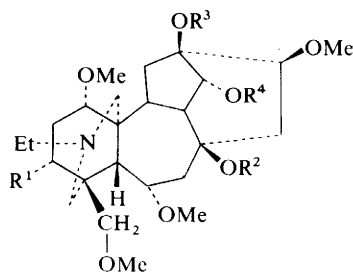

Pseudoaconitine	(29) $R^1 = R^3 = OH; R^2 = Ac; R^4 = Veratroyl$
Bikhaconitine	(30) $R^1 = R^3 = H; R^2 = Ac; R^4 = Veratroyl$
Chasmaconitine	(31) $R^1 = R^3 = H; R^2 = Ac; R^4 = Bz$
Indaconitine	(32) $R^1 = OH; R^2 = Ac; R^3 = H; R^4 = Bz$
Veratroylpseudoaconine	(33) $R^1 = OH; R^2 = R^3 = H; R^4 = Veratroyl$
Diacetylpseudoaconitine	(34) $R^1 = OAc; R^2 = R^3 = Ac; R^4 = Veratroyl$

obtained. Acetylation of pseudoaconitine with acetic anhydride–toluene-*p*-sulphonic acid gave (34). These products were identical with the naturally occurring alkaloids.

3 C₂₀ Diterpenoid Alkaloids

Vakognavine.—Singh and co-workers¹⁸ have published additional chemical and spectral evidence supporting the earlier structure work on vakognavine,¹⁹ a novel seco-diterpenoid alkaloid. This base, C₃₄H₃₇NO₁₀, m.p. 298 °C, was isolated from root tubers of *Aconitum palmatum* Don.²⁰ The earlier work, including an X-ray crystallographic structure determination of the hydriodide derivative (36), led to the assignment of structure (35) to vakognavine.¹⁹

The additional u.v., ¹H n.m.r., and i.r. spectral data for vakognavine and several derivatives are consistent with the assigned structure.

Vakognavine formed a bis-hydrazone, which was characterized as the reineckate salt. On catalytic hydrogenation, a hexahydro-product (37) was obtained. Selective acid hydrolysis with 50% sulphuric acid afforded, after 4½ minutes, a diacylamine (38); after 13½ minutes, a monoacylamine (39); and after 2 hours, a completely deacylated alkamine (40). These structures were assigned from the spectral data.

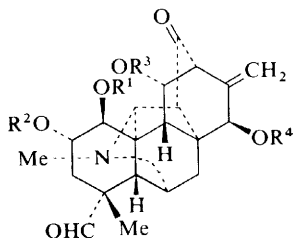

Vakognavine	(35) $R^1 = R^3 = R^4 = Ac; R^2 = Bz$
	(38) $R^1 = R^4 = H; R^2 = Bz; R^3 = Ac$
	(39) $R^1 = R^2 = R^4 = H; R^3 = Ac$
	(40) $R^1 = R^2 = R^3 = R^4 = H$

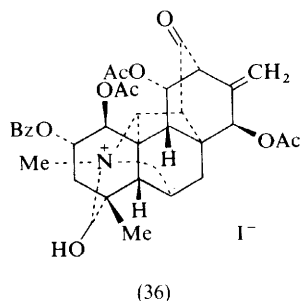

¹⁸ A. Singh, S. S. Jaswal, and H. Singh, *Indian J. Chem.*, 1974, **12**, 1219.

¹⁹ S. W. Pelletier, K. N. Iyer, L. H. Wright, M. G. Newton, and N. Singh, *J. Amer. Chem. Soc.*, 1971, **93**, 5942.

²⁰ N. Singh and A. Singh, *J. Indian Chem. Soc.*, 1965, **42**, 49.

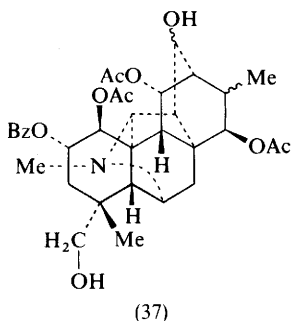

Miyaconitine and Miyaconitinone.—A brief report of further chemical studies of miyaconitine (41) and miyaconitinone (42) has been published.²¹ These modified atisine-type alkaloids were isolated from *Aconitum miyabei* Nakai.²²

Acid hydrolysis of miyaconitinone afforded miyaconinone (43). Miyaconine (44) was obtained by treatment of miyaconitine with molar methanolic potassium hydroxide, by oxidation of (41) with alkaline triphenyltetrazolium chloride solution, and by treatment of (43) with 5% HCl.

Apomiyaconine (45) was produced by refluxing (44) with molar methanolic potassium hydroxide for 2 hours. The structures of miyaconine (44) and apomiyaconine were assigned from spectral information. A table of ¹³C n.m.r. spectral data is included in this communication. From this and molecular model considerations, the authors assigned the β -configuration to the hydrogen atom at C-5 in (44) and (45).

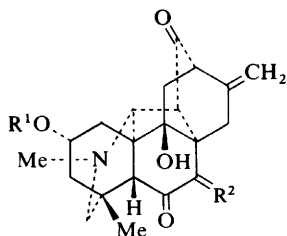

Miyaconitine (41) $R^1 = \text{Ac}$; $R^2 = \begin{array}{c} \text{OH} \\ \diagup \\ \text{H} \end{array}$

Miyaconitinone (42) $R^1 = \text{Ac}$; $R^2 = \text{O}$

Miyaconinone (43) $R^1 = \text{H}$; $R^2 = \text{O}$

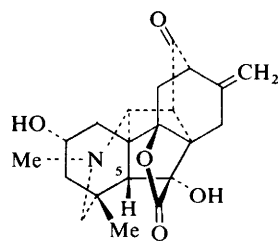

Miyaconine (44)

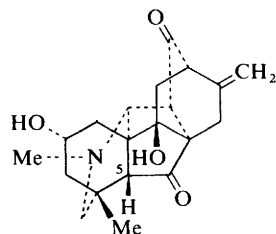

Apomiyaconine (45)

²¹ Y. Ichinohe, M. Yamaguchi, and K. Matsushita, *Chemistry Letters*, 1974, 1349.

²² Y. Ichinohe, M. Yamaguchi, N. Katsui, and S. Kakimoto, *Tetrahedron Letters*, 1970, 2323.

The rearrangement of (41) and (42) to (44) provides an explanation for the formation of anthracene in the dehydrogenation of (42)²³ and for the formation of (44) during chromatographic purification of (41) and (42).²⁴

Rearrangements.—Two reports of rearrangements of C₂₀ diterpenoid alkaloids have appeared,^{25,26} which are of biogenetic interest. The first involves an atisine-lycoctonine conversion and the second a rearrangement of a lucidusculine derivative.

Atisine-Lycoctonine Conversion. Przybylska, Tsai, and Wiesner have converted atisine (46) into the lycoctonine-type ketone (47).²⁵

After the earlier work of Johnston and Overton,²⁷ the alcohols (49) and (50) were obtained by borohydride reduction of (48), obtained from atisine. The α -alcohol (50) was purified by preparative t.l.c. and converted into the tosylate (51). On heating (51) with tetramethylguanidine in DMSO, an 85% yield of a mixture of isomers (52) and (53) was obtained. Compound (52) is identical with the product earlier prepared by pyrolytic rearrangement.²⁷ Hydrogenation of (52) or (53) afforded the same dihydro-derivative. Deacetalization of (53) to the ketone (54) followed by reduction with lithium aluminium hydride afforded a mixture of the hydroxy-amines (55) and (56). These were treated with mercuric acetate to yield compounds (57) and (58). Jones' oxidation of this epimeric mixture afforded compound (47). The structure of this compound was confirmed by an X-ray crystallographic analysis.

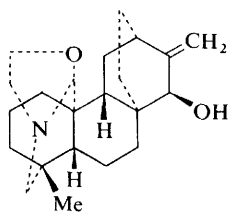

Atisine (46)

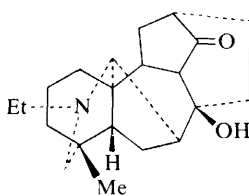

(47)

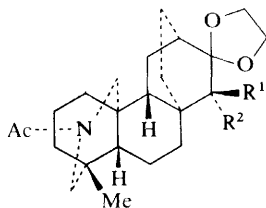

- (48) R¹R² = O
 (49) R¹ = OH; R² = H
 (50) R¹ = H; R² = OH
 (51) R¹ = H; R² = OTs

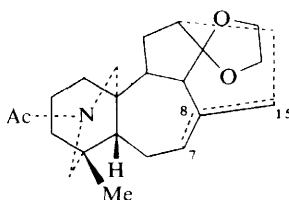

- (52) $\Delta^{8,15}$
 (53) $\Delta^{7,8}$

²³ H. Sugimoto and S. Kakimoto, *Bull. Chem. Soc. Japan*, 1959, **32**, 352.

²⁴ A. Ichihara and T. Matsumoto, *Bull. Chem. Soc. Japan*, 1974, **47**, 1030.

²⁵ M. Przybylska, T. Y. Tsai, and K. Wiesner, *J.C.S. Chem. Comm.*, 1975, 297.

²⁶ M. Kodama, H. Kurihara, and S. Itô, *Tetrahedron Letters*, 1975, 1301.

²⁷ J. P. Johnston and K. H. Overton, *J.C.S. Perkin I*, 1972, 1490.

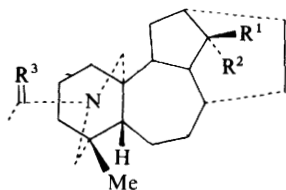

- (54) $R^1 R^2 = O$; $R^3 = O$
 (55) $R^1 = H$; $R^2 = OH$; $R^3 = H_2$
 (56) $R^1 = OH$; $R^2 = H$; $R^3 = H_2$

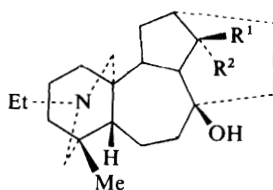

- (57) $R^1 = OH$; $R^2 = H$
 (58) $R^1 = H$; $R^2 = OH$

This work adds additional support for the proposed biosynthetic transformation of the C_{20} atisine bases into the lycotonine alkaloids by rearrangement in the C and D ring systems followed by formation of the C-7—C-20 bridge.²⁸⁻³⁰

Veatchine Skeletal Rearrangement. That the C-7—C-20 bridge might be formed prior to rearrangement has been proposed by Kodama, Kurihara, and Itô.²⁶ They effected a rearrangement to a highly strained ring system in their synthetic studies on napelline.³¹ When the mesylate (59) was heated in DMSO at 115 °C, two products were formed, the normal 1,2-elimination product (60) and a rearranged product (61). This mixture was reduced with one equivalent of borohydride to the keto-alcohols (62) and (63). The structures were determined by 1H n.m.r. studies of these compounds and their corresponding acetate derivatives, (64) and (65), respectively. The indicated stereochemical assignments were supported by c.d. studies. The keto-acetate (65) was reduced with borohydride to the hydroxy-acetate (66). Catalytic hydrogenation of (63) afforded (67).

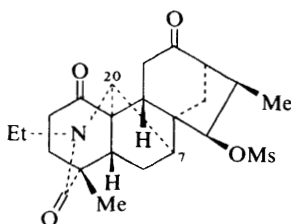

(59)

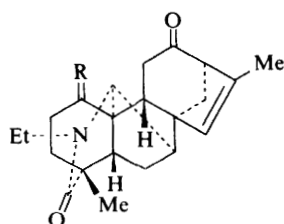

- (60) $R = O$
 (62) $R = \begin{array}{l} OH \\ H \end{array}$
 (64) $R = \begin{array}{l} OAc \\ H \end{array}$

²⁸ Z. Valenta and K. Wiesner, *Chem. and Ind.*, 1956, 354.

²⁹ R. C. Cookson and M. E. Trevett, *J. Chem. Soc.*, 1956, 3121.

³⁰ O. E. Edwards, *Chem. Comm.*, 1965, 318.

³¹ T. Okamoto, M. Natsume, Y. Iitaka, A. Yoshino, and T. Amiya, *Chem. and Pharm. Bull. (Japan)*, 1965, 13, 1270.

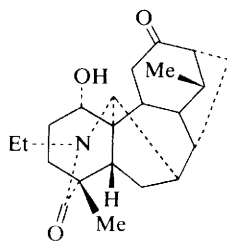
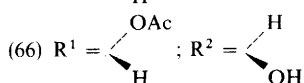
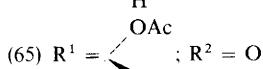
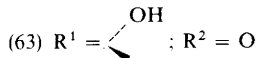
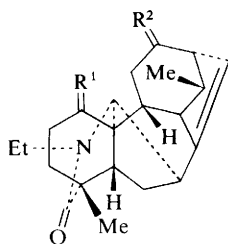

(67)

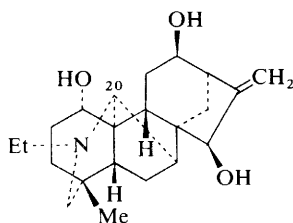

Napelline (68)

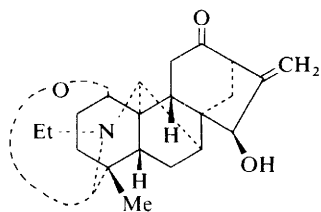

Songoramine (69)

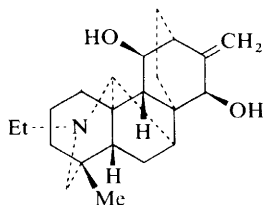

Denudatine (70)

Since C_{20} diterpenoid alkaloids with a 7,20-bridge [including napelline (68), songoramine (69), and denudatine (70)] have been isolated, this rearrangement demonstrates that the C-7—C-20 bond formation may be independent of the skeletal rearrangement. From the preformed C-7—C-20 bridged-veatchine system, the rearrangement might proceed as indicated in Scheme 1.³⁰

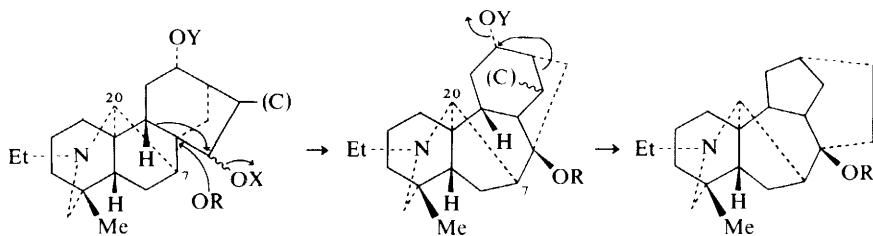

Scheme 1

Synthetic Studies.—Mander *et al.* have published a series of studies on intramolecular alkylation which include methodologies applicable to diterpenoid syntheses.³²⁻³⁵

In work directed towards elaboration of the nitrogen bridge system of the diterpenoid alkaloids, the antipodal lactam (71) was synthesized from podocarpic acid.³² One of the routes examined was *via* the nitrile (73), obtained by the ethyl chloroformate dehydration of *O*-methylpodocarpamide (72). Oxidation of (73) with chromium trioxide afforded the ketone (74) and a minor amount of the hydroxy-diketone (75). Oxygenation of (74) with potassium *t*-butoxide gave a mixture of the lactam (76) (62%) and the diosphenol (77) (9%). Hydrogenation of this lactam yielded (71). Reduction of (71) with lithium aluminium hydride afforded the pyrrolidine derivative; however, attempts to prepare *N*-halogeno-derivatives of this compound for transannular functionalization at C-20 gave only dehydro-derivatives.

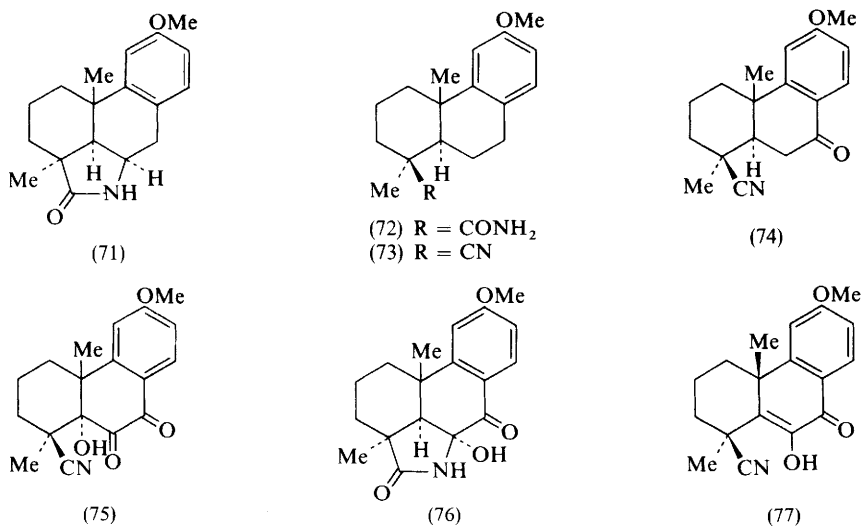

4 *Daphniphyllum* Alkaloids

Four new alkaloids have been isolated from the fruits of *Daphniphyllum teijsmanni* Zollinger.^{36,37} These bases are minor components and co-occur with daphnilactone-B (5), which is the major alkaloid.³⁸

Daphnitejmsmine.—C₃₂H₄₉NO₅, m.p. 187—188 °C, gave an *N*-acetyl derivative on acetylation with acetic anhydride–pyridine. By comparison of the spectral data with

³² B. S. Balgir, L. N. Mander, and R. H. Prager, *Austral. J. Chem.*, 1974, **27**, 1245.

³³ D. J. Beames and L. N. Mander, *Austral. J. Chem.*, 1974, **27**, 1257.

³⁴ D. J. Beames, T. R. Klose, and L. N. Mander, *Austral. J. Chem.*, 1974, **27**, 1269.

³⁵ S. W. Johnson and L. N. Mander, *Austral. J. Chem.*, 1974, **27**, 1277.

³⁶ S. Yamamura and Y. Hirata, *Tetrahedron Letters*, 1974, 2849.

³⁷ S. Yamamura and Y. Hirata, *Tetrahedron Letters*, 1974, 3673.

³⁸ K. Sasaki and Y. Hirata, *Tetrahedron Letters*, 1972, 1891.

those of daphniphylline (1) and secodaphniphylline (2), daphniteijsmine was determined to be acetoxysecodaphniphylline (78). This base offers an alternative biogenetic pathway to daphniphylline other than the proposed acetoxylation of codaphniphylline (79).³⁶

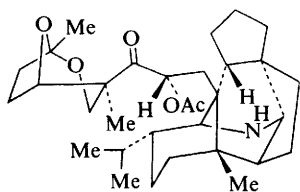

Daphniteijsmine (78)

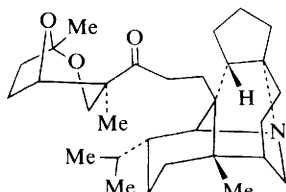

Codaphniphylline (79)

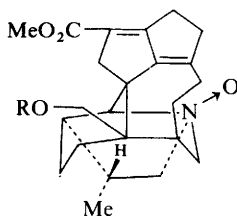
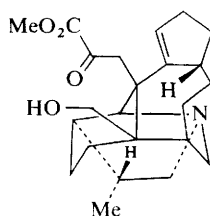
Daphnijsmine (80a) R = Ac
Desacetyldaphnijsmine (80b) R = H

(81)

Daphnijsmine and Desacetyldaphnijsmine.—These alkaloids, $C_{25}H_{33}NO_5$, m.p. 205—207 °C, and $C_{23}H_{31}NO_4$, m.p. 200 °C, contain amine oxide functionalities. From spectral data and biogenetic considerations, structures (80a) and (80b), respectively, were assigned.³⁵ These alkaloids may be classified in the yuzurimine group. The $\alpha\beta,\gamma\delta$ -unsaturated methoxycarbonyl system suggests that they may have been derived from a precursor (81) related to daphnilactone-B.³⁶

Daphniteijsmanine.—This new base $C_{30}H_{49}NO_3$, m.p. 228—232 °C, has an acetal moiety not previously observed in the *Daphniphyllum* alkaloids.³⁷ 1H N.m.r. and mass spectral data indicate that daphniteijsmanine has the same basic skeleton as secodaphniphylline (2), but contains a different acetal portion. By comparison of the 1H n.m.r. spectral data, the acetal grouping of daphniteijsmanine (82) was found to differ only in stereochemistry from the degradation product (83) of daphniphylline.

For chemical confirmation, *N*-acetylsecodaphylline (84) was reduced to (85) with sodium borohydride. On heating the mesylate (86) with acetic acid, *N*-acetyldaphniteijsmanine acetate (87) was obtained. This derivative was also prepared by acylation of (82) with acetic anhydride–pyridine.³⁷

Yuzurine.—From the bark and leaves of *Daphniphyllum macropodum* Miquel, a new alkaloid, yuzurine, $C_{24}H_{37}NO_4$, has been isolated as a colourless viscous liquid.³⁹ This base was previously identified as the Alkaloid-A₂.⁴⁰

³⁹ S. Yamamura, K. Sasaki, M. Toda, and Y. Hirata, *Tetrahedron Letters*, 1974, 2023.

⁴⁰ M. Toda, Y. Hirata, and S. Yamamura, *Tetrahedron*, 1972, 28, 1477.

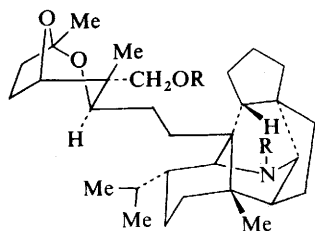

Daphniteijsmanine (82) R = H
(87) R = Ac

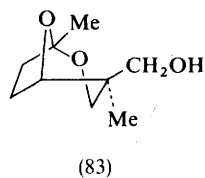

(83)

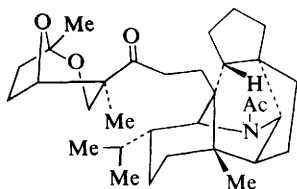

(84)

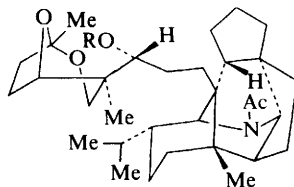

(85) R = H
(86) R = Ms

The structure of yuzurine was determined to be (88) by an X-ray crystallographic study of the methiodide derivative, employing a heavy-atom method.³⁹ This structure accounts for the observed chemical and physical data. The proposed biosynthetic pathway from yuzurimine-B (89) is indicated in Scheme 2.³⁹

Yuzurine, which may be included in the yuzurimine class, differs from the previously isolated *Daphniphyllum* alkaloids in that it has no 2-azabicyclo-[3,3,1]nonane system.

Further reports on the chemistry of daphniphylline (1), methyl homodaphniphyllate (90), and daphnilactone-B, isolated from *Daphniphyllum teijsmanni* Zollinger, *D. macropodum* Miquel, and *D. humile* Maxim, have appeared.^{2,41}

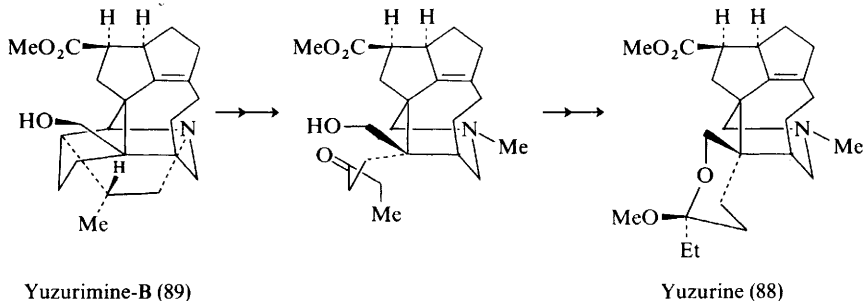

Yuzurimine-B (89)

Yuzurine (88)

Scheme 2

⁴¹ H. Niwa, M. Toda, S. Ishimara, Y. Hirata, and S. Yamamura, *Tetrahedron*, 1974, **30**, 3031.

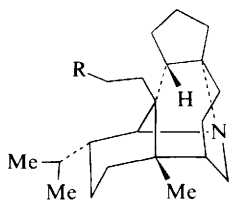

Methyl homodaphniphyllate (90) R = CO₂Me
Daphnialcohol acetate (91) R = OAc

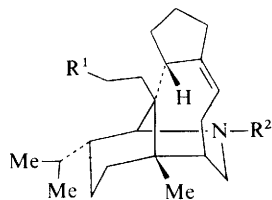

(92) R¹ = OAc; R² = CN
(93) R¹ = OAc or OH; R² = H

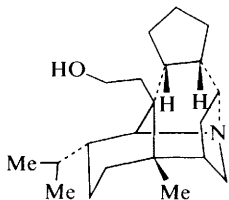

(94)

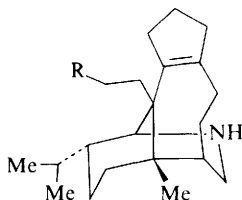

(95) R = OAc or OH

Daphniphylline.⁴¹—On oxidation with sodium metaperiodate followed by reduction with sodium borohydride and acetylation, daphniphylline (1) was converted into daphnialcohol acetate (91).⁴² Treatment of (91) with excess cyanogen bromide afforded the cyanamide (92). On heating (92) with 6-M methanolic HCl, an amine (94) containing a new heterocyclic skeleton was obtained, possibly *via* the intermediate (93). Compound (94) was transformed into the original cyanamide (92) by von Braun degradation and acetylation. The secondary amine (95) proposed as a biogenetic intermediate⁴³ could not be obtained.

Methyl Homodaphniphyllate.—Daphniphylline has been converted into methyl homodaphniphyllate (90).² Treatment of daphnialcohol (96) with toluene-*p*-sulphonyl chloride in pyridine gave the tosylate (97). Treatment of (97) with ethanolic potassium cyanide afforded a mixture of the nitrile (98) and the amide (99). This mixture was hydrolyzed with aqueous HCl, and the resulting acid was esterified with methanolic HCl to afford (90). The authors proposed that methyl

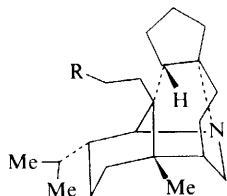

Daphnialcohol (96) R = OH
(97) R = OTs
(98) R = CN
(99) R = CONH₂

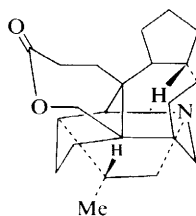

(100)

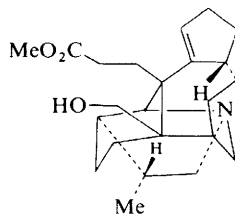

(101)

⁴² H. Irikawa, N. Sakabe, S. Yamamura, and Y. Hirata, *Tetrahedron*, 1968, **24**, 5691.

⁴³ H. Irikawa, S. Yamamura, and Y. Hirata, *Tetrahedron*, 1972, **28**, 3727.

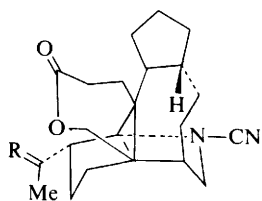

- (102) R = H, CH₂Br
 (103) R = CH₂
 (104) R = OH, CH₂OH
 (105) R = O
 (106) R = H, Me

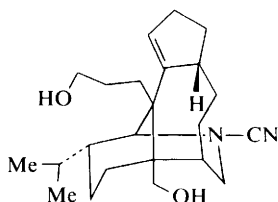

(107)

homodaphniphyllate results from the oxidative cleavage of codaphniphylline (79) or its precursor.²

Daphnilactone-B.—The structure of this alkaloid was determined by chemical and spectral analyses^{2,41} and was previously confirmed by an X-ray crystallographic analysis.³⁸ Catalytic hydrogenation of daphnilactone-B (5) gave (100). Treatment of (5) with methanolic sodium methoxide afforded the methyl ester (101), which reverted to the original lactone on standing. von Braun degradation of daphnilactone-B gave the bromocyanamide (102).⁴¹ On reaction of (102) with silver fluoride in pyridine, the olefin (103) was obtained. Oxidation of (103) by osmium tetroxide produced the glycol (104). Treatment with sodium metaperiodate converted (104) into (105). Reduction of (102) with a slight excess of borohydride gave (106), while a large excess resulted in a diol (107). On heating with 90% formic acid, (106) gave (109), presumably through the intermediate (108). von Braun degradation of (109) afforded (110), which is an isomer of (106).

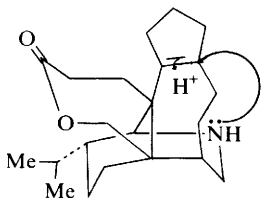

(108)

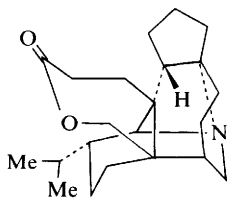

(109)

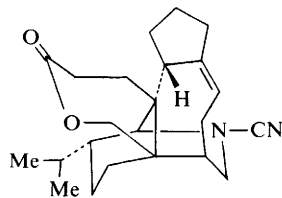

(110)

Steroidal Alkaloids of the Apocynaceae, Buxaceae, Asclepiadaceae, and of the *Salamandra-Phyllobates* Group

BY F. KHUONG-HUU AND R. GOUTAREL

1 Alkaloids of the Apocynaceae

Steroidal Alkaloids and Amines.—*Synthesis, Reactions, and Transformations of Steroidal Amines.* 5α -Androstanols and (hydroximino)- 5α -androstanes give, by standard procedures, the amino- and the acetamido- 5α -androstanes at the positions 3, 4, 6, 7, 11, 16, and 17.¹

The synthesis of $[4-^{14}\text{C}]$ - $3\alpha,20\alpha$ -diaminopregn-5-ene, ($[4-^{14}\text{C}]$ -3-epi-irhediamine A) was effected starting from $[4-^{14}\text{C}]$ pregnenolone or from $[4-^{14}\text{C}]$ - 3β -trimethylsilyloxypregna-3,5-diene.²

(2*S*)- 3β -Dimethylamino-18,20-diacetoxy- 5α -pregnane (1) was prepared from 20β -hydroxy- 5α -pregnan-3-one cyclic ethylene ketal (2) in six steps. The key steps were iodination of (2) with HOI and cyclization to ether (3).³

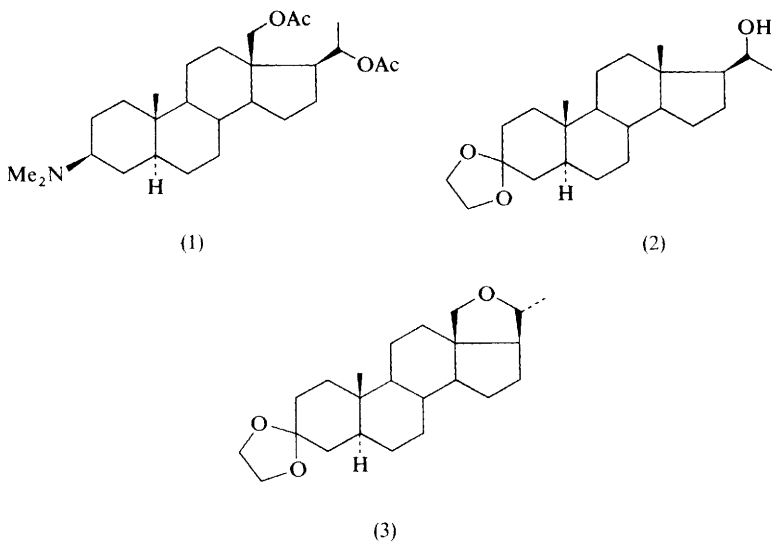

¹ D. B. Cowell, A. K. Davis, D. W. Mathieson, and P. D. Nicklin, *J.C.S. Perkin, I*, 1974, 1501.

² H. Hoellinger, N. Hoang-Nam, and L. Plichat, *Bull. Soc. chim. France*, 1975, 237.

³ Omnium Chimique S. A., Belg. P. 806 437 (*Chem. Abs.*, 1974, **81**, 37 728).

N-(trifluoroacetyl)-isofuntumidine (4) was iodinated, epoxidized, and deacylated to give derivative (5). After *N*-methylation and ring cleavage, (2*S*)-3 α -dimethylaminopregnane-18,20-diol (6) was obtained.⁴

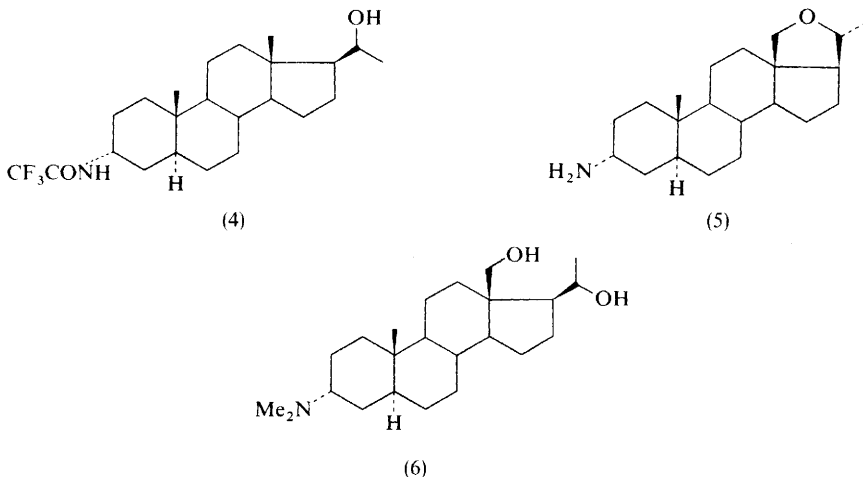

The synthesis of steroidal compounds possessing an amino function at angular carbon atoms was effected by reducing the corresponding azides.^{5,6} The azides were obtained by treatment of steroidal olefins or alcohols with $\text{HN}_3\text{-BF}_3\cdot\text{OEt}_2$ in benzene solution. Thus, treatment of 6 β -hydroxy-5 α -pregnane (7) with $\text{HN}_3\text{-BF}_3\cdot\text{OEt}_2$ gave the 5 α - and 5 β -azidopregnanes (8a) and (9a), with C-5 to C-6 hydride transfer. The kinetic product was 5 α -azidopregnane (8a), which epimerized into a thermodynamic mixture of the two azides. This epimerization was catalysed by HN_3 .⁵

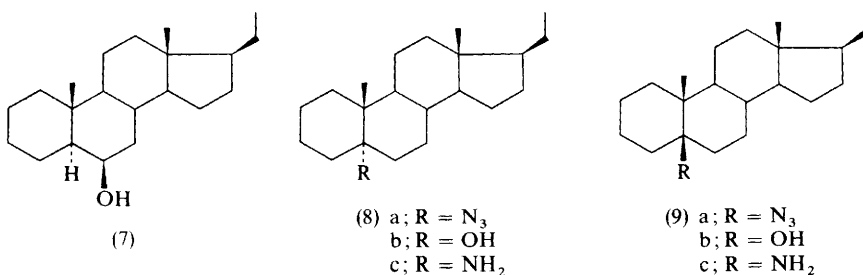

The 5 α - and 5 β -hydroxypregnanes (8b) and (9b), with $\text{HN}_3\text{-BF}_3\cdot\text{OEt}_2$ and benzene, gave, *via* the 4- or 5-olefin, a mixture of the 5 α - and 5 β -azides, (8a) and (9a). Under the same conditions, pregn-4-ene and pregn-5-ene gave the same mixture of 5-azides.⁶

Similarly, 18,19-dinor-5 β ,14 β -dimethylpregn-13(17)-ene (10), gave, regioselectively and stereoselectively, the 13 β -azido derivative (11a), and androst-14-ene (12)

⁴ Omnium Chimique S.A., Belg. P. 811 304 (*Chem. Abs.*, 1975, **82**, 73 311).

⁵ A. Pancrazi and Q. Khuong-Huu, *Tetrahedron*, 1974, **30**, 2586.

⁶ A. Pancrazi and Q. Khuong-Huu, *Tetrahedron*, 1974, **30**, 2343.

gave the 14β -azidoandrostane (13a). Nucleophilic attack by HN_3 on a π -complex between BF_3 and the steroidal olefin was invoked to explain this stereoselectivity.⁶ Reduction of the azides afforded the corresponding amines (8c), (9c), (11b), and (13b). Chemical degradation, mass spectra, and ^{13}C n.m.r. studies led to these structural assignments.

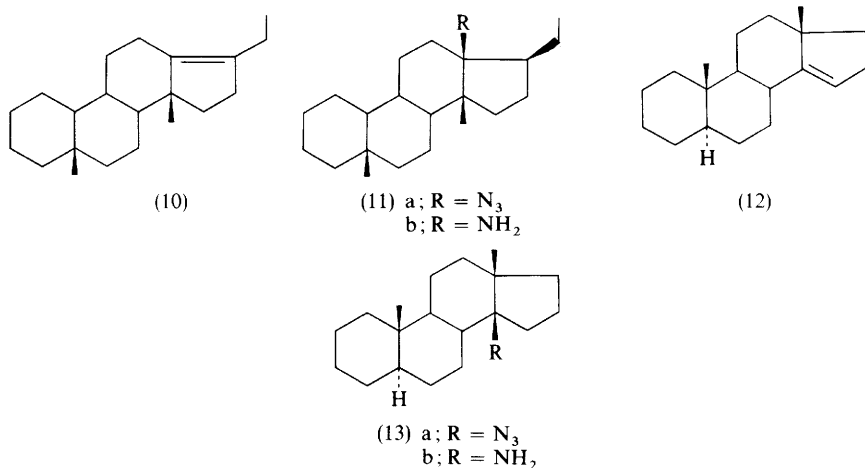

By the action of H_2SO_4 on dihydroxyconessine (14), 3β -dimethylaminoconona-4,6-diene (15) and 3β -dimethylamino-conanin-6-one (16) were obtained.⁷

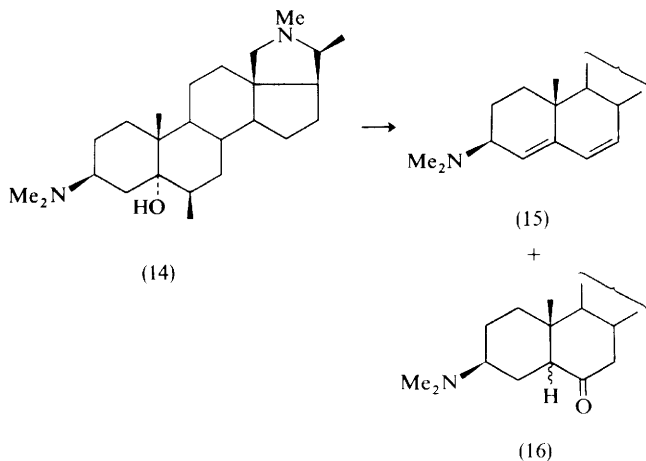

Oxidation of cyclic tertiary amines with hydrogen atoms α to the nitrogen, by bromine or *N*-bromosuccinimide under basic conditions, has been investigated.⁸ Experimental conditions for lactam formation were precisely defined. 21-Norconanine (17) and 20-methylconanine (18) with one mole of bromine (or NBS) in the

⁷ M. A. Khan, *Pakistan J. Sci. Ind. Res.*, 1974, **16**, 197 (*Chem. Abs.*, 1974, **81**, 25 853).

⁸ A. Picot and X. Lusinchi, *Synthesis*, 1975, 109.

presence of aqueous sodium hydroxide led to the iminium salts (19) and (20), respectively, which could be easily isolated. With two moles of reagent the lactams (23) and (24) were obtained *via* the hydroxyamines (21) and (22).

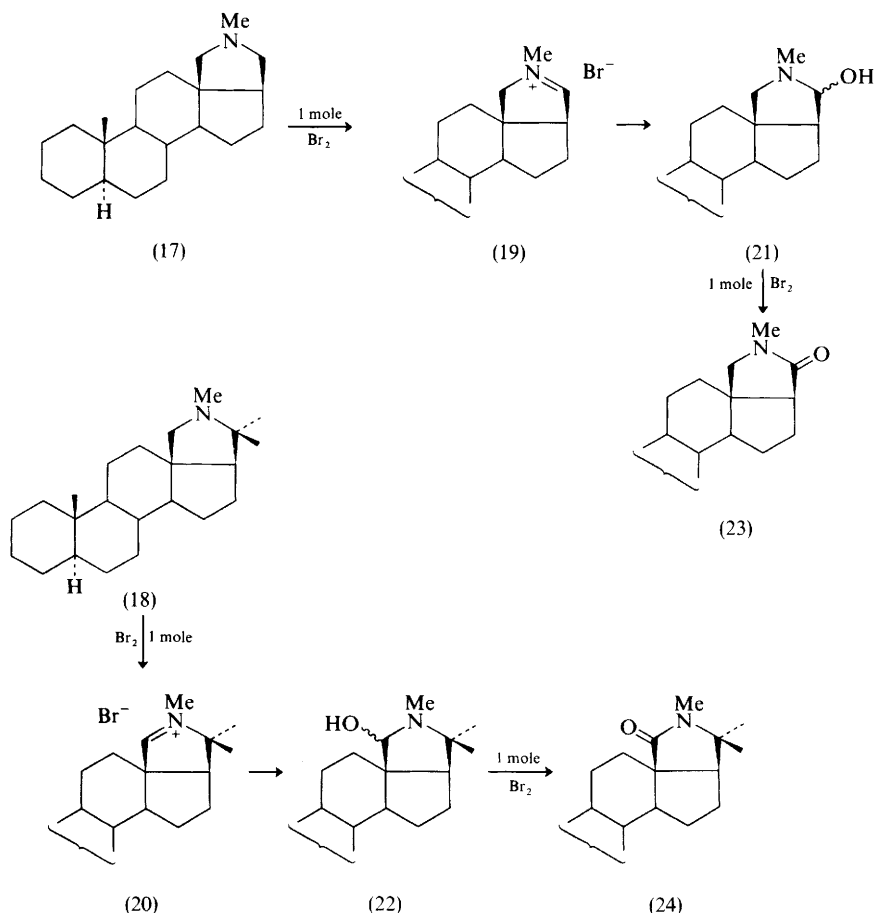

Oxidation of conanine (25) to the lactam (28) required four moles of bromine. In this case, by analogy with the reactions of a methyl ketone, it may be assumed that the iminium salt (26), formed in the first step, was perbrominated at position 21 to give (27), and that tribromomethane was eliminated under the action of alkali (haloform reaction).

The isomerization of oxaziridines derived from conanine, under basic or acidic conditions, has been studied.⁹ The hydrolysis of oxaziridines gave either a hydroxylamine and a carbonyl compound, or an amine (or ammonia) and two carbonyl compounds (Scheme 1). The first step in this hydrolysis was base- or acid-catalysed isomerization of oxaziridines to iminocarbinols or nitrones.

⁹ P. Milliet and X. Lusinchi, *Tetrahedron*, 1974, **30**, 2825.

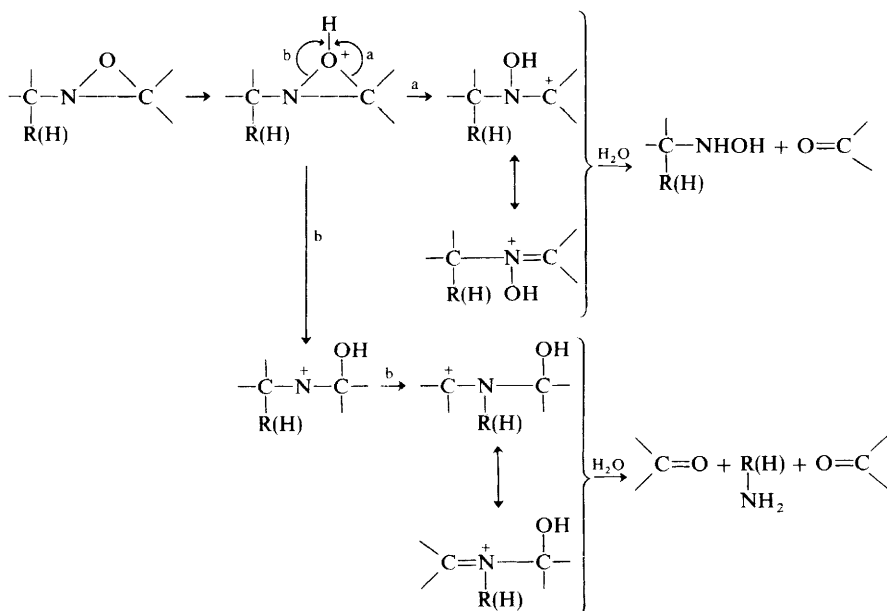
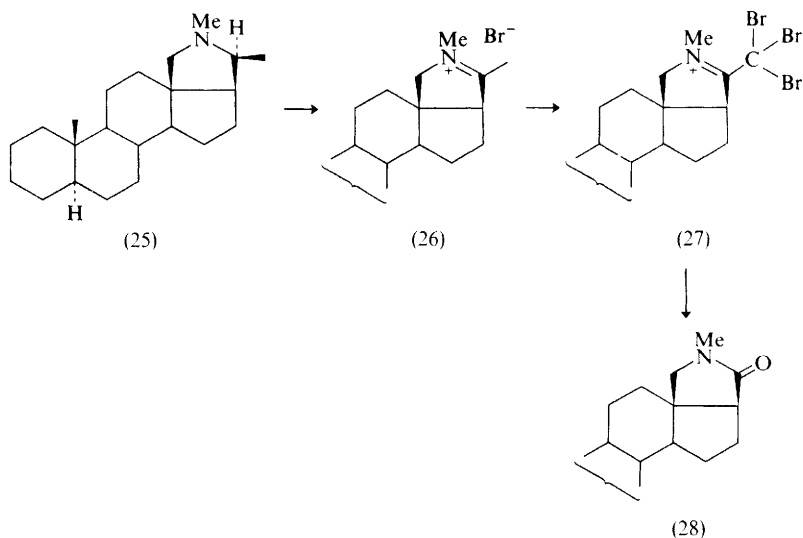

Scheme 1

The oxaziridine (29), with KOH in refluxing EtOH, gave the imino-ether (30) and the conjugated ketone (31). The formation of these compounds may be explained by Scheme 2, where the diketo-derivative led to (31) by crotonization. At 20 °C, with KOH in EtOH, starting from (29), the iminocarbinals (32) can be isolated.

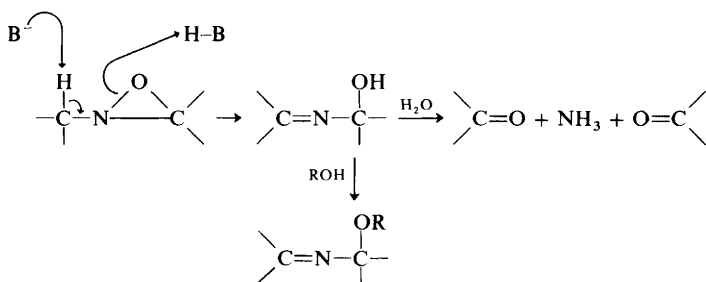
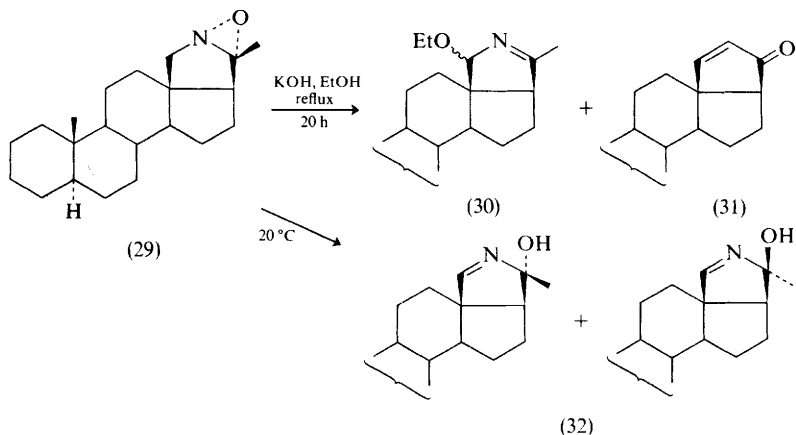

Scheme 2

The oxaziridine (33), with the 18 α -H *cis* to the N—O bond, was stable under alkaline conditions, whereas the oxaziridine (34), with the 18 β -H *trans* to the N—O bond, gave the α -hydroxylated imino-ether (35). A *trans* elimination mechanism is involved.

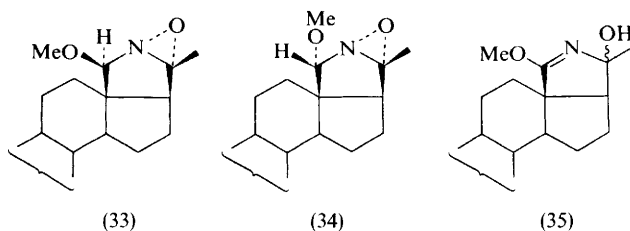

With H₂SO₄ in aqueous THF or with toluene-*p*-sulphonic acid monohydrate in benzene (29) gave a mixture of the iminocarbinols (36), *via* rapid isomerization of the iminocarbinols (32); the iminocarbinols (36) dimerized slowly to (37) (Scheme 3). With BF₃·OEt₂, (29) gave quantitatively the nitrone (38). With HCl, (29) afforded the imine (39). With acids, a *trans* elimination mechanism was also observed: the

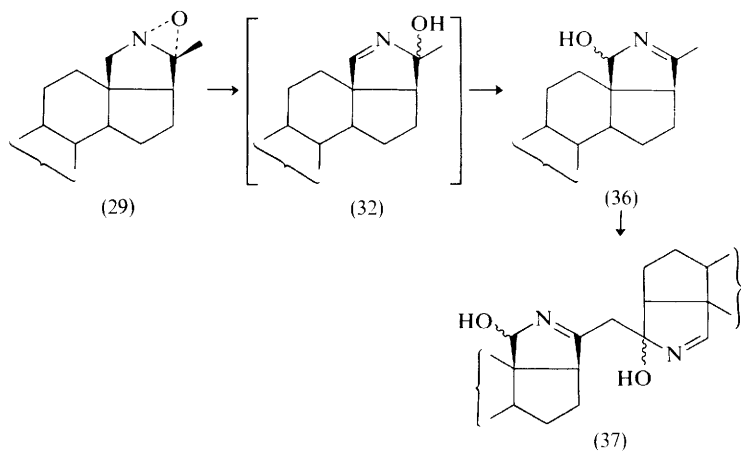

Scheme 3

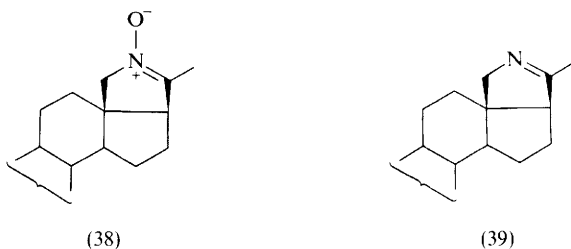

oxaziridine (33), with $18\alpha\text{-H}$ *cis* to the N—O bond, was isomerized to the α -methoxynitron (40), which dimerized to (41), whereas the oxaziridine (34), with $18\beta\text{-H}$ *trans* to the N—O bond, gave the α -methoxyiminocarbinal (42).⁹

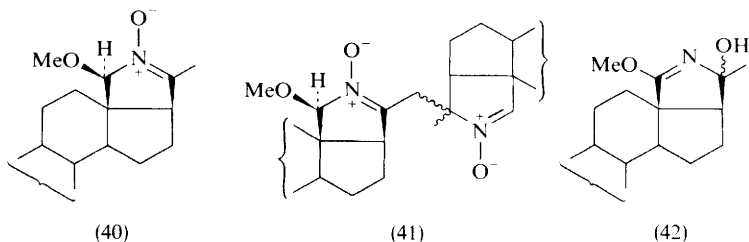

The hydrolysis of the iminocarbinals (32) and (36) was also investigated.¹⁰ Under acidic conditions, the iminocarbinals (32) were isomerized to (36), which were hydrolysed to the ketoaldehyde (43). Partial epimerization at C-17 of (43) gave (44) (Scheme 4). In neutral media (THF-H₂O), the hydrolysis of (32) and (36) led to (43) [(44) was not formed], and the isomerization of (32) to (36) was not observed. In acidic medium, isomerization was faster than hydrolysis, whereas in neutral medium

¹⁰ P. Milliet and X. Lusinchi, *Tetrahedron*, 1974, **30**, 2833.

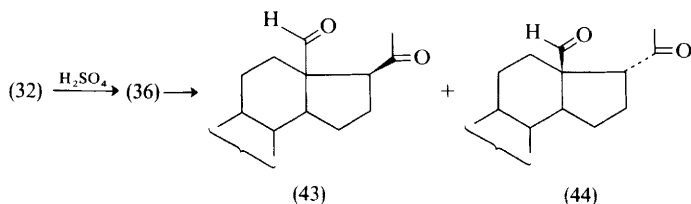

Scheme 4

hydrolysis was faster than isomerization. Alkaline hydrolysis of (36) afforded the ethylenic ketone (31). In these conditions (KOH-EtOH, 20 °C, 70 h), (32) gave a mixture of (30) and (31). With methanol, the iminocarbinals (32) gave a mixture of epimeric 18-methoxyimines (45). By oxidation with *p*-nitroperbenzoic acid the mixture of epimers (45) led to the two oxaziridines (33) and (34), which were isolated.¹⁰

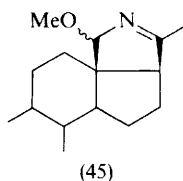

Allylic substitution of steroidal olefins by a modified Treibs reaction has been described.¹¹ With mercury(II) trifluoroacetate, allylic substitution of steroidal olefins (3β -hydroxyandrost-5-en-17-one acetate, cholesterol derivatives) proceeded under milder conditions (even at 0 °C) than with mercury(II) acetate; the 6β -hydroxy- Δ^4 -compounds were obtained. Similarly, paravallarine derivatives (46; R = H, Me, COMe, or $COCF_3$) gave 6β -hydroxy-compounds (47) (yields 18–46%). In this case it was possible to isolate, in neutral medium, the isomeric 4β -hydroxy- Δ^5 -compounds (48).

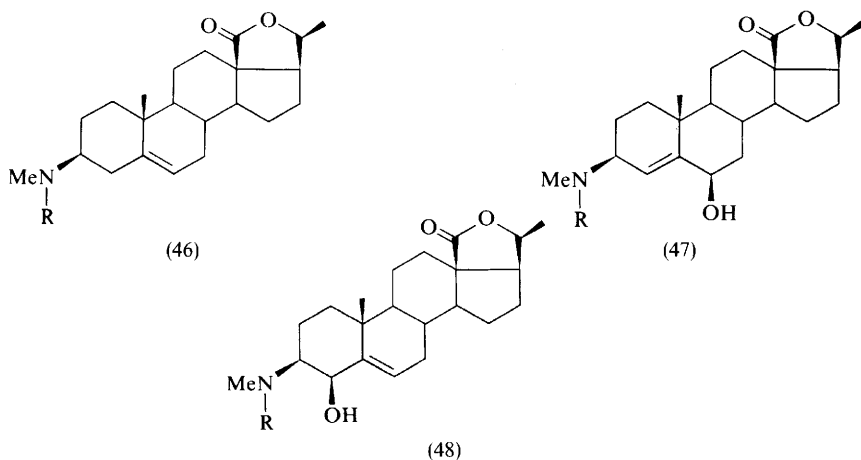

¹¹ G. Massiot, H.-P. Husson, and P. Potier, *Synthesis*, 1974, 722.

Photochemistry. Irradiation of tertiary amines in the presence of dyes and oxygen gives secondary amines and oxygenated compounds (amides, lactams). The mechanism of formation of these oxygenated compounds has been investigated.¹² Irradiation of conanine (25) in the presence of methylene blue and oxygen led to (28) and (49a), whilst in the presence of eosin and oxygen the photo-products were (28), (49a), (50), and (51). In the presence of eosin, oxygen, and KCN, photolysis of (25) led to (49a), (49b), and (52). When the irradiation was effected in the presence of dye,

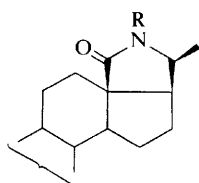

(49) a; R = Me
b; R = H

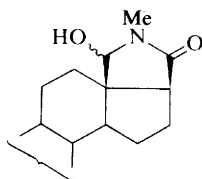

(50)

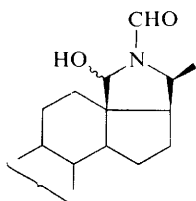

(51)

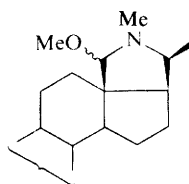

(52)

oxygen, and sodium pyruvate, only the epimers (52) were formed. Inhibition of the formation of the oxygenated photo-products by sodium pyruvate was also observed in the tropanol series. These results pointed to a mechanism in which the oxygenated products were formed by action of hydrogen peroxide (produced by interaction of oxygen with photosensitizers) on an intermediate immonium ion. Pyruvate rapidly reacted with H_2O_2 and therefore prevented the formation of oxygenated products.

N.M.R. Spectra. A ^{13}C n.m.r. study of (22*R*)- and (22*S*)-cholesterol amino- and hydroxy-derivatives has been reported.¹³ The magnitude of the β -effect and, to a lesser extent, of the γ -effect, was totally different for the (22*R*) and (22*S*) compounds. The interpretation of this fact is not easy, but these results seem to be structurally diagnostic and may be helpful for stereochemical assignments of C-22 epimers in steroids.

2 Alkaloids of the Asclepiadaceae

The isolation and structure determination of condurangamines A (53) and B (54) from the bark of *Marsdenia condurango* Reichenb. have been reported.¹⁴

¹² F. Khuong-Huu, D. Herlem, and Y. Hubert-Brierre, *Tetrahedron Letters*, 1975, 359.

¹³ Y. Letourneux, O. Khuong-Huu, M. Gut, and G. Lukacs, *J. Org. Chem.*, 1975, **40**, 1674.

¹⁴ M. Pailer and D. Ganzinger, *Monaish.*, 1975, **106**, 37.

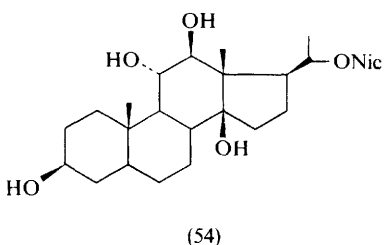
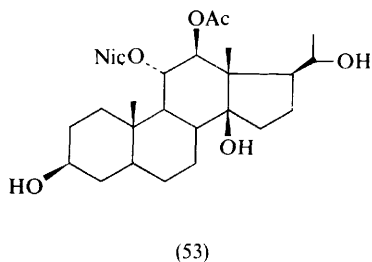

3 Salamandra Alkaloids

The synthesis of the alkaloid (55), isolated from *Cryptobranchus maximus* Stanley, has been described.¹⁵ Reaction of 17 β -acetoxyandrosta-1,4-dien-3-one (56) with NBS and benzoyl peroxide, followed by refluxing with DMF-CaCO₃, afforded 17 β -acetoxyandrosta-1,4,6-trien-3-one (57). Treatment of the latter with hydrogen peroxide afforded (58) as main product and (59) and (60) as minor products. Derivative (58) was hydrogenated to (61), which, on Schmidt reaction with HN₃ and H₂SO₄, yielded (62) and (63) as major products. The isomeric lactams (62) and (63) were separated, and reaction of (62) with lithium in ethylamine in the presence of 2-methyl-propan-2-ol gave (55) in reasonable yield. Reduction of (63) to (64) and attempted re-oxidation of (64) with argentic picolinate gave a complex mixture containing (55).

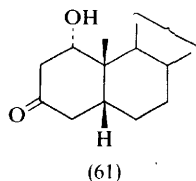
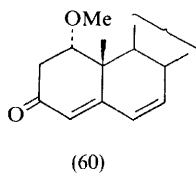
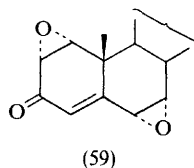
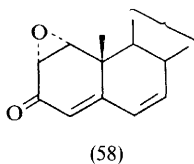
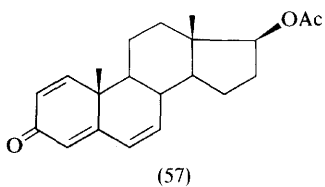
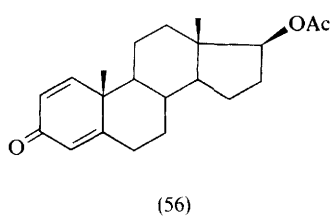
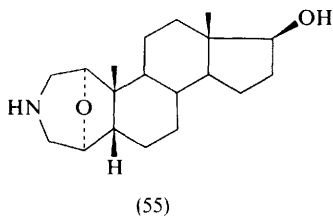

¹⁵ M. Benn and R. Shaw, *Canad. J. Chem.*, 1974, **52**, 2936.

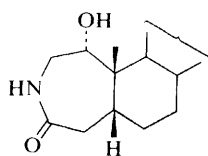

(62)

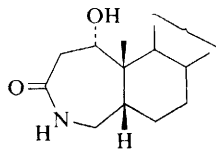

(63)

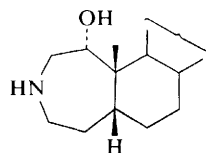

(64)

4 *Buxus* Alkaloids

A ^{13}C n.m.r. study of *Buxus* alkaloids having at C-4 a hydroxymethylene and a methyl group (65) showed unambiguously the axial configuration at C-4 of the methyl group, leading to a structural revision of these alkaloids.¹⁶ The hydroxymethylene is 4α -equatorial and the methyl group 4β -axial. This was confirmed by an X-ray crystallographic study effected on (66),¹⁷ the thermolysis product of *N*-isobutyrylcyclohexobuxidine F.

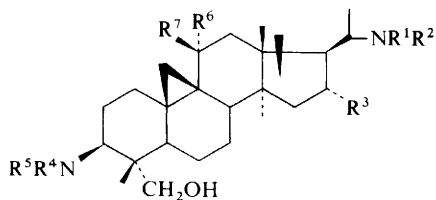

(65)

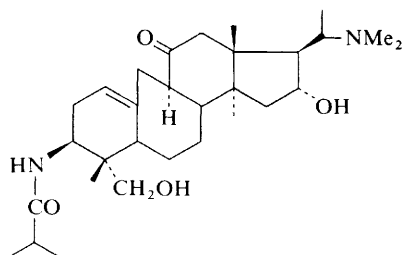

(66)

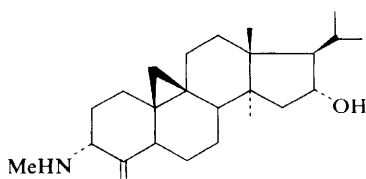

(67)

A review of the *Buxus* alkaloids with the $9\beta,19$ -cyclo- 14α -methyl- 5α -pregnane skeleton has been published.¹⁸ Pseudocyclohexobuxine D (67), the 3-epimer of cyclohexobuxine D, was isolated from *Buxus sempervirens*.¹⁹ Structural assignment was achieved by i.r., n.m.r., and m.s. studies. Buxtauine, cyclomicrobuxine, cyclohexobuxine D, cycloprotobuxine C, and *N*₃-benzoylcyclohexobuxidine F have been isolated from the leaves of *Buxus hyrcana* Pojark.^{20,21}

¹⁶ M. Sangaré, F. Khuong-Huu, D. Herlem, A. Milliet, B. Septe, G. Berenger, and G. Lukacs, *Tetrahedron Letters*, 1975, 1791.

¹⁷ J. Guilhem, *Tetrahedron Letters*, 1975, 2935.

¹⁸ W. Turowska and Y. Wrzeciono, *Wiad. Chem.*, 1973, **27**, 869.

¹⁹ B. U. Khodzhaev, R. Shakirov, and S. Yu. Yunusov, *Khim. prirod. Soedinenii*, 1973, 755 (*Chem. Abs.*, 1974, **81**, 152 510).

²⁰ A. M. Aliev and G. M. Orazmuradov, *Khim. prirod. Soedinenii*, 1974, 409.

²¹ I. O. Kurakina, O. N. Tolkachev, and D. A. Pakal'n, *Khim. prirod. Soedinenii*, 1974, 814.

5 Biological Notes

Here, syntheses of steroidal amines having biological activities, are reported.

Quaternary salts with MeBr and $\text{CH}_2=\text{CHCH}_2\text{Br}$ of $2\beta,16\beta$ -diaminoandrostanes have been prepared. Mono- and di-quaternary salts of (68) are fast-acting muscle relaxants with short duration.²²

The azanorcholesterol (69), which possesses antihyperadrenocortical activity, has been prepared by condensing 20α -aminopregn-5-en- 3β -ol (holafebrine) (70a) with Me_2CHCHO and subsequent NaBH_4 reduction. The azahomocholesterol (71), having similar activity, was prepared by condensation of (70b) with $\text{Me}_2\text{CH}(\text{CH}_2)_2\text{COCl}$ and subsequent LiAlH_4 reduction and hydrolysis.²³

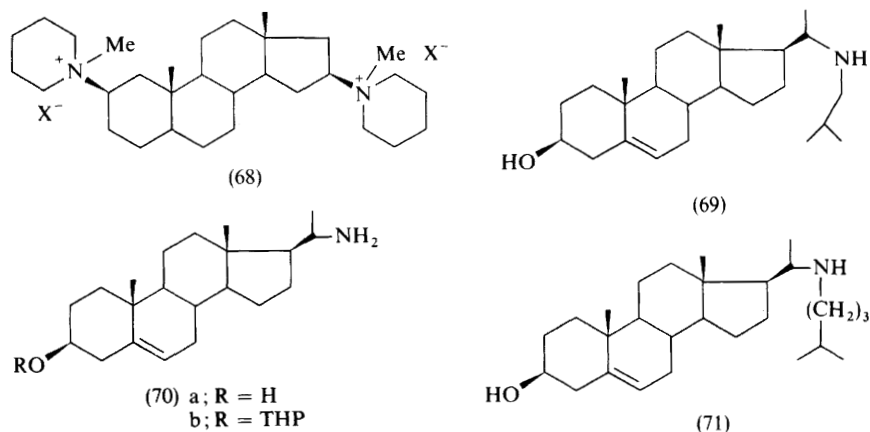

Some 21-dialkylamino-20-methylpregna-4,17-dien-3-ones (72)²⁴ and 3-oxygenated-23-dialkylamino-22-methyl-24-norchola-4(or 5),20(22)-dienes (73)²⁵ possessing bactericidal activity have been prepared.

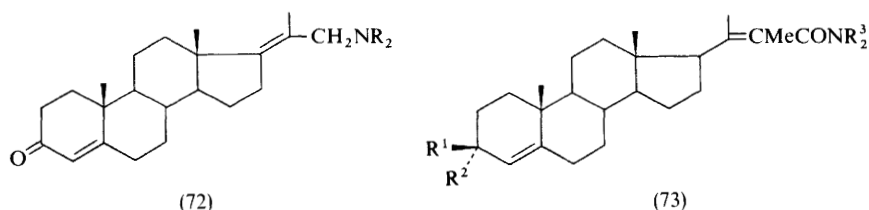

Some 17β - and 17α -amino-steroids (74), which are antibacterial and antifungal agents, have been synthesized by reducing 17-oxo-steroids with $\text{R}^1\text{R}^2\text{NH}$, by reducing 17-azido- or 17-hydroximino-steroids to 17-amino-steroids, or by alkylating the amino-steroids.²⁶

²² C. L. Hewett and D. S. Savage, Ger. Offen., 2 359 076 (*Chem. Abs.*, 1974, **81**, 91 805).

²³ R. E. Counsell and M. C. H. Lu, U.S. P. 3 818 055 (*Chem. Abs.*, 1974, **81**, 78 158).

²⁴ G. R. Lenz, U.S. P. 3 810 926 (*Chem. Abs.*, 1974, **81**, 37 732).

²⁵ G. R. Lenz, U.S. P. 3 847 954 (*Chem. Abs.*, 1975, **82**, 73 314).

²⁶ H. Mori, R. Ouchi, Y. Kurosawa, J. Yamada, Y. Takahashi, and Y. Hiram, Japan Kokai, 74 54 358 (*Chem. Abs.*, 1975, **81**, 120 860).

Synthesis and evaluation of antimicrobial properties of amidinoaza-androstanes, as (75), and guanidinoaza-androstanes, as (76), have been achieved.²⁷ The synthesis and the antimicrobial activity of 4-aza-5 α -sitostane (77a) and its 4-methyl derivative (77b) have been reported.²⁸

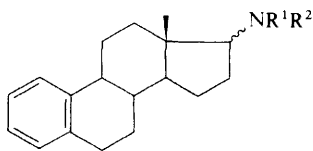

(74)

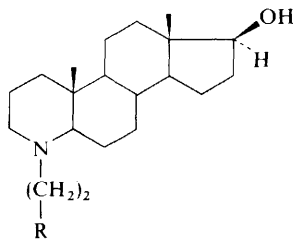
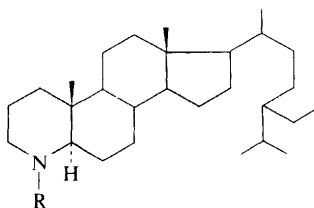
(75) R = NH₂
(76) R = NHC(NH₂)=NH(77) a; R = H
b; R = Me

Chandonium iodide (78), a neuromuscular blocking agent, and 4-methyl-17 β -dimethylamino-4-aza-5 α -androstane dimethiodide (79) have been prepared from 17-aza-D-homoandrost-4-ene-3,17-dione and from androst-4-ene-3,17-dione, respectively.²⁹

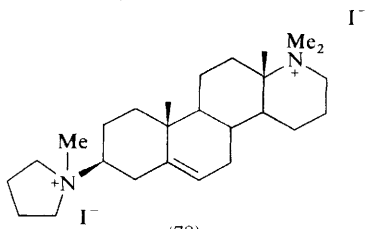

(78)

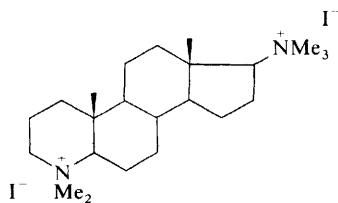

(79)

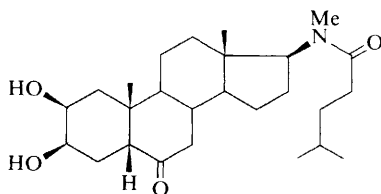

(80)

Derivative (80) showed medium activity for inhibition of post-ecdysial cuticle sclerotization in *Pyrhocoris apterus*.³⁰

²⁷ N. J. Doorenbos and J. C. Kim, *J. Pharm. Sci.*, 1974, **63**, 620.

²⁸ H. Y. Aboul Enein and N. J. Doorenbos, *J. Heterocyclic Chem.*, 1974, **11**, 557.

²⁹ H. Singh and D. Paul, *J.C.S. Perkin I*, 1974, 1475.

³⁰ Z. Machkova and V. Černý, *Coll. Czech. Chem. Comm.*, 1974, **39**, 1091.

Solanum and *Veratrum* Steroidal Alkaloids

BY D. M. HARRISON

The material of this review is discussed in *Solanum* and *Veratrum* sections in accordance with precedent,¹ although the division of material between these sections is sometimes arbitrary. Related steroidal alkaloids isolated from other genera are discussed in that section which seems most appropriate on structural grounds.

The *Solanum* and *Veratrum* alkaloids form part of the material of two reviews on biochemical aspects of plant steroids.²

1 *Solanum* Alkaloids

Solasodine (1) and related *Solanum* alkaloids³ are useful starting materials for the commercial preparation of steroid hormones.⁴ In particular the pregnane derivative (6) was prepared⁵ from solasodine in 65% overall yield *via* the intermediates (2), (3), and (4). The oxidative cleavage of the 20(22) double bond of pseudosolasodine diacetate (3), which is the least efficient step in this synthesis, has been investigated in more detail.⁶ With sodium dichromate in acetic acid compound (3) gave⁶ the hydroxyester (5) and the hydroxylactone (7), in addition to the ester (4). Results of a kinetic study of this reaction were interpreted in terms of formation of hydroxyester (5) *via* allylic oxidation of pseudosolasodine diacetate prior to cleavage of the 20(22) double bond.⁷

A number of nitrogen heterocycles have been prepared from solasod-4-en-3-one (8) in a search for new physiologically active steroids.⁸ Reaction of (8) with ethyl formate and sodium hydride gave the formyl derivative (9), which cyclized with methylhydrazine, phenylhydrazine, and *p*-nitrophenylhydrazine to give the pyrazoles (11), (12), and (13), respectively. Similarly, (8) was condensed with ethyl trifluoroacetate to give (10), which reacted with hydrazine and with hydroxylamine to give pyrazole (14) and isoxazole (16), respectively. Heterocycles (15) and (17)

¹ (a) R. B. Herbert, in 'The Alkaloids', ed. J. E. Saxton, (Specialist Periodical Reports), The Chemical Society, London, 1973, Vol. 3, p. 279; (b) R. B. Herbert, *ibid.*, 1974, Vol. 4, p. 383.

² E. Heftmann, *Lipids*, 1974, **9**, 626; E. Heftmann, *Phytochemistry*, 1975, **14**, 891.

³ K. Schreiber, in 'The Alkaloids', ed. R. H. F. Manske, Academic Press, New York, 1968, Vol. 10, p. 1.

⁴ K. Schreiber, in ref. 3, pp. 106-115.

⁵ Y. Sato, N. Ikekawa, and E. Mosettig, *J. Org. Chem.*, 1960, **25**, 783.

⁶ G. G. Malanina, L. I. Klimova, L. M. Morozovskaya, O. S. Anisimova, L. M. Alekseeva, and N. N. Suvorov, *Khim. Farm. Zhur.*, 1974, **8**, 18 (*Chem. Abs.*, 1974, **81**, 63 874).

⁷ L. M. Morozovskaya, L. I. Klimova, G. G. Malanina, N. K. Genkina, L. N. Finyakin, and N. N. Suvorov, *Zhur. org. Khim.*, 1974, **10**, 2125 (*Chem. Abs.*, 1975, **82**, 86 496).

⁸ G. S. Khatamkulova, M. I. Goryaev, and M. P. Irismetov, *Izvest. Akad. Nauk. Kazakh. S.S.R. Ser. khim.*, 1974, **24**, 71 (*Chem. Abs.*, 1974, **81**, 152 509).

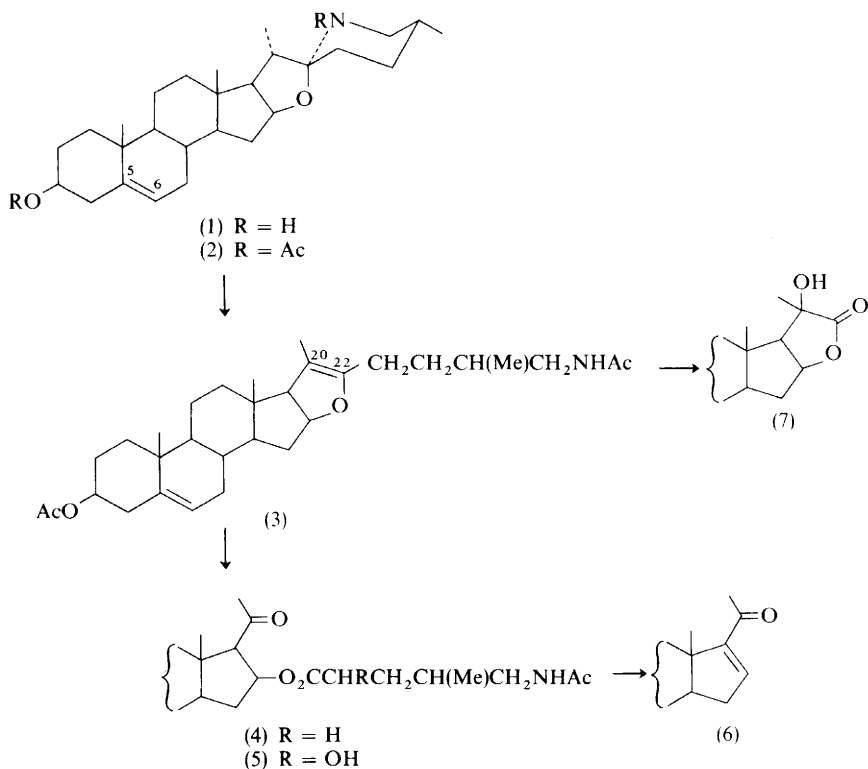

were also prepared.⁸ This work is an extension of the earlier reported preparation of nitrogen heterocycles from 5 α -solasodan-3-one.⁹

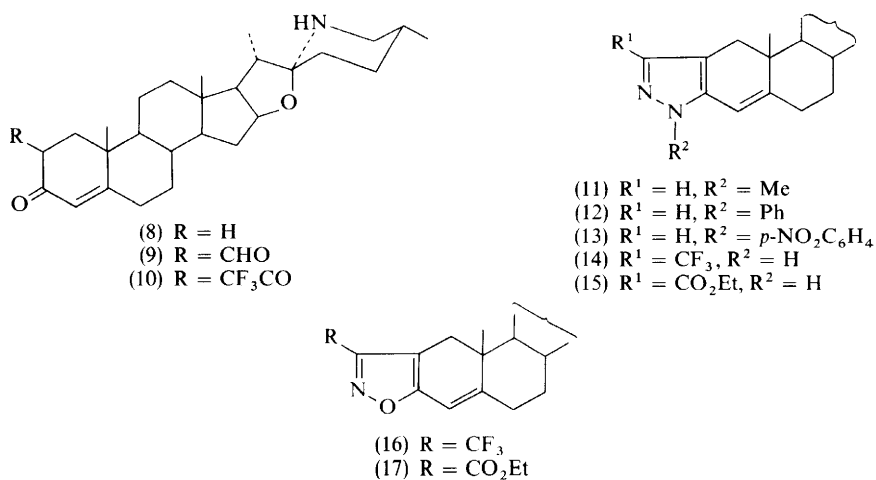

⁹ M. I. Goryaev, M. P. Irismetov, and G. N. Romachenko, *Izvest. Akad. Nauk. Kazakh. S.S.R., Ser. khim.*, 1973, **23**, 70 (*Chem. Abs.*, 1973, **78**, 136 522); R. B. Herbert in ref. 1b, p. 387.

Ozonolysis of solasodine (1) and of the derived enone (8), with oxidative work-up, gave the keto-acids (18) and (19), respectively.¹⁰ These products were characterized as their methyl esters and as the acetates of the products of lithium aluminium hydride reduction of the methyl esters. Ozonolyses of (20) and (21) to give analogous products were also described.¹⁰ The aglycone (22) of the steroidal glycoside osladine has been synthesized from solasodine *via* the azomethine (23) and ketone (24).¹¹

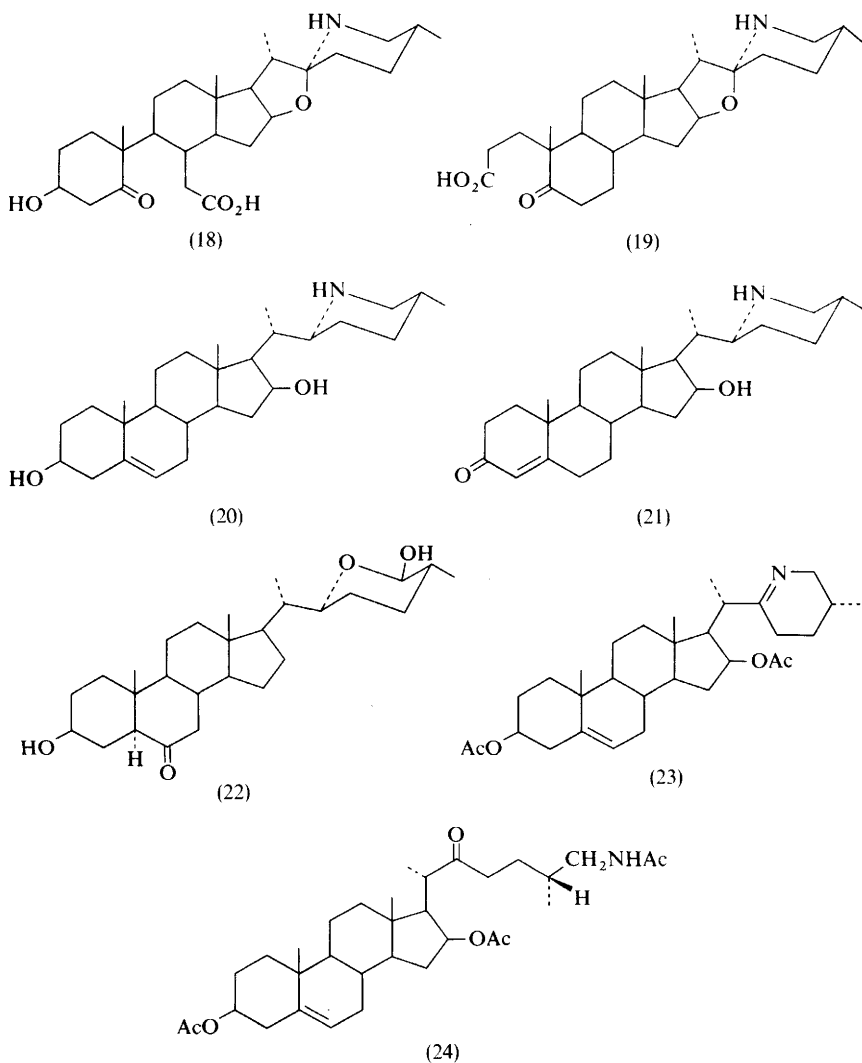

¹⁰ G. N. Romachenko, M. I. Goryaev, and M. P. Irismetov, *Izvest. Akad. Nauk. Kazakh. S.S.R. Ser. khim.*, 1974, **24**, 42 (*Chem. Abs.*, 1975, **82**, 73 306).

¹¹ M. Havel and V. Černý, *Coll. Czech. Chem. Comm.*, 1975, **40**, 1579.

Chromatography on a cation-exchange resin has been studied¹² as a means of separating the glycoalkaloids of *Solanum laciniatum*. Sorption isotherms of the solasodine glycosides α -solamargine, β -solamargine, and solasonine were measured.¹²

A new solasodine glycoside, solaplumbin, has been isolated¹³ from aerial parts of *Nicotiana plumbaginifolia*. Structure (25) was proposed for the glycoside on the basis of microanalytical data and the degradations outlined below.¹³

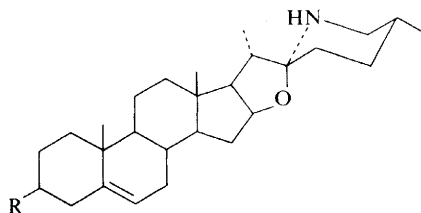

(1) R = OH

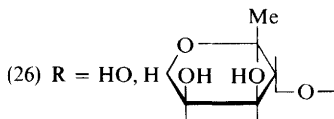
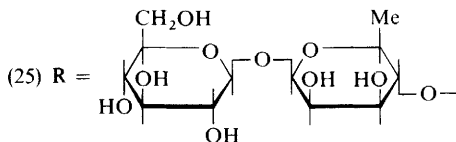

Acid hydrolysis of solaplumbin gave solasodine (1) and the monosaccharides glucose and rhamnose in a 1 : 1 molar ratio. The glycoside formed a hexa-*O*-acetate and a hexa-*O*-methyl ether, which on acid hydrolysis gave 2,3,4,6-tetra-*O*-methylglucose and 2,3-di-*O*-methylrhamnose. Enzymic hydrolysis of solaplumbin with takadiastase gave a second glycoside, solaplumbinin, and glucose, which was interpreted to mean that solaplumbin was a β -glucoside. Solaplumbinin yielded only solasodine and rhamnose on acid hydrolysis and, like the parent glycoside, solaplumbin, gave only one mole of formic acid on treatment with sodium metaperiodate. Solaplumbinin showed reducing properties, which precluded attachment of the aglycone to C-1 of rhamnose. Accordingly, structure (26) was proposed for solaplumbinin and (25) for the natural glycoside, solaplumbin.¹³ Further evidence for the postulated ether linkage of solasodine to rhamnose and for the anomeric configurations of the monosaccharide residues in solaplumbin would be desirable. This glycoside, which possesses anticancer activity,¹³ appears to be the first solasodine derivative to be isolated from a *Nicotiana* species.¹⁴

The solasodine glycosides solasonine and solamargine have been isolated from dried leaves of *Solanum persicum*.¹⁵ The same glycosides were found in unripe fruits

¹² L. G. Andreeva, *Khim. Farm. Zhur.*, 1974, **8**, 52 (*Chem. Abs.*, 1975, **82**, 129 205).

¹³ S. Singh, N. M. Khanna, and M. M. Dhar, *Phytochemistry*, 1974, **13**, 2020.

¹⁴ For a comprehensive list of species containing *Solanum* glycoalkaloids, see K. Schreiber in ref. 3 pp. 6-18.

¹⁵ E. N. Novruzov and S. M. Aslanov, *Khim. prirod. Soedinenii*, 1974, 109 (*Chem. Abs.*, 1974, **81**, 60 822).

of *S. oleraceum*, together with traces of a third unidentified glycoside.¹⁶ Dried fruits of an unidentified *Solanum* species (Spanish name 'naranjilla de jbaro') have yielded solasonine and two minor unidentified glycoalkaloids.¹⁷ Acid hydrolysis of the crude glycoalkaloid extract gave solasodine in high overall yield (4.65%).¹⁷ Five unidentified glycoalkaloids were detected in the stems and leaves of *S. elaeagnifolium*, while the roots contained in addition a sixth glycoalkaloid.¹⁸ The glycoalkaloid extract of the leaves furnished a good yield of solasodine.^{18,19} Previous work on this plant had established the presence of the solasodine glycosides solamargine and solasurine in the berries.²⁰ Solasodine has also been isolated from the acid hydrolysate of crude glycoalkaloid extracts from ripe berries of *S. aethiopicum*,²¹ and from leaves and stems of *S. laciniatum*,²² a known source¹⁴ of this alkaloid. The alkaloid content of 13 *Solanum* species (Morella section) was examined.²³ Of the four previously unexamined species, no alkaloids were detected in *S. maximowiczii* and *S. humistratum*, while *S. maritimum* and *S. judaicum* both contained glycoalkaloids with solasodine as aglycone.²³

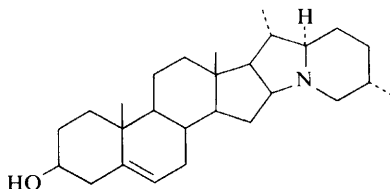

(27)

Plant sources for the industrial isolation of the solanidine (27) glycoside, solanine, have been reviewed.²⁴ Solanidine was isolated for the first time from *Rhinopetalum stenanthrum* (*Fritillaria* sp.), together with two unidentified alkaloids.²⁵ Yields of the crude alkaloid mixture from the aerial and below-ground parts of the plant were 0.1 and 0.5%, respectively. The solanidine glycosides α -solanine, α -chaconine, and γ -chaconine have been isolated²⁶ from *S. tuberosum*, a known source¹⁴ of these glycoalkaloids.

Studies on the regional variation of the alkaloid content of *S. dulcamara* have been summarized.²⁷ Two main chemical taxa have been identified: a West European taxon, in which tomatidenol (28) glycosides are predominant, and an East European

¹⁶ P. Bite and M. M. Shabana, *Acta Chim. Acad. Sci. Hung.*, 1974, **83**, 91 (*Chem. Abs.*, 1975, **82**, 82 964).

¹⁷ M. C. Guevara and D. P. Martinod, *Politecnica*, 1972, **2**, 107 (*Chem. Abs.*, 1975, **82**, 95 255).

¹⁸ M. R. Kulkarni and G. S. Pendse, *Planta Med.*, 1974, **25**, 249.

¹⁹ Cf. B. L. Kaul and U. Zutshi, *Indian J. Pharm.*, 1973, **35**, 94 (*Chem. Abs.*, 1973, **79**, 102 764).

²⁰ D. K. Seth, *J. Inst. Chemists (India)*, 1971, **43**, 116 (*Chem. Abs.*, 1972, **76**, 1802).

²¹ S. K. Banerjee, V. George, and R. Kapoor, *Planta Med.*, 1974, **25**, 216.

²² A. A. Saleh, *Pharmazie*, 1974, **29**, 346; A. A. Saleh, *Planta Med.*, 1974, **26**, 40.

²³ I. Mathe, jun. and I. Mathe, *Acta Pharm. Hung.*, 1974, **44**, Suppl., 19 (*Chem. Abs.*, 1975, **82**, 13 993).

²⁴ I. I. Gerasimenko, *Rast. Resur.*, 1974, **10**, 42 (*Chem. Abs.*, 1974, **81**, 41 300).

²⁵ K. Samikov, R. Shakirov, and S. Yu. Yunusov, *Khim. prirod. Soedinenii*, 1974, 537 (*Chem. Abs.*, 1975, **82**, 14 013).

²⁶ A. Nabiev and R. Shakirov, *Khim. prirod. Soedinenii*, 1974, 116 (*Chem. Abs.*, 1974, **81**, 60 825).

²⁷ I. Mathe and I. Mathe, jun., *Acta Bot. Acad. Sci. Hung.*, 1973, **19**, 441 (*Chem. Abs.*, 1974, **81**, 35 555).

taxon in which soladulcidine (5,6-dihydrosolasodine) glycosides are more important.²⁷ The variation of alkaloid content in different parts of this plant has been investigated.²⁸

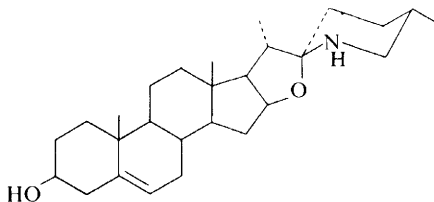

(28)

2 *Veratrum* Alkaloids

Recent progress in the chemistry of the *Veratrum* alkaloids has been reviewed in detail.²⁹ Brief reviews have appeared on aspects of the chemistry³⁰ of these alkaloids and on the cardiac action³¹ of the ceveratrum alkaloids.

Verazine (37)³² has been the subject of a formal total synthesis (Scheme 1)³³ based on the earlier reported versatile syntheses of solanidine³⁴ and tomatidenol.³⁵ As in the earlier work,^{34,35} Michael addition of the anion of the configurationally pure nitro-ester (30) to (29) gave the C-22 epimeric mixture (31), from which the individual diastereomers were isolated after acetylation. The (22*S*)-acetate (32) was converted³³ *via* thioketal (34) and lactam (35) into the piperidine derivative (36). Base treatment of the *N*-chloro-derivative of (36) then gave^{33,36} verazine (37).

The conversion of (36) into (37) clearly involves loss of asymmetry at C-22. However, the initial separation of the C-22 epimers (32) and (33) was considered to be desirable³³ since earlier work had shown³⁷ that the C-22 epimer of (36) could not be readily transformed into verazine. Both diastereomers (32) and (33) showed abnormally high extinction coefficients in the 280 nm region of their u.v. spectra owing to coupling between the ketone and nitro chromophores. Molecular models indicated that such an interaction would be less sterically hindered in the (22*S*)-isomer than in the (22*R*)-isomer. Accordingly, the isomer with the higher extinction coefficient was assigned³³ the (22*S*) structure (32).

²⁸ I. Mathe, jun., *Bot. Kozlem.*, 1974, **61**, 133 (*Chem. Abs.*, 1975, **82**, 152 200).

²⁹ J. Tomko and Z. Votický, in 'The Alkaloids', ed. R. H. F. Manske, Academic Press, New York, 1973, Vol. 14, p. 1.

³⁰ W. Wiegrebe, *Arzneim. Forsch.*, 1974, **24**, 288; M. L. Boasio and A. Tafanelli, *Relata Tech. Chim. Biol. Appl.*, 1974, **6**, 169.

³¹ M. Reiter and P. Honerjäger, *Arzneim. Forsch.*, 1974, **24**, 290.

³² J. Tomko and Z. Votický, in ref. 29, pp. 20-21.

³³ S. V. Kessar, A. Sharma, M. Singh, and R. K. Mahajan, *Indian J. Chem.*, 1974, **12**, 1245 (*Chem. Abs.*, 1975, **82**, 156 576).

³⁴ S. V. Kessar, A. L. Rupal, S. S. Gandhi, and R. K. Mahajan, *Tetrahedron*, 1971, **27**, 2153.

³⁵ S. V. Kessar, Y. P. Gupta, M. Singh, and R. K. Mahajan, *Tetrahedron*, 1971, **27**, 2869; cf. R. B. Herbert, in ref. 1a, pp. 284-287.

³⁶ G. Adam, K. Schreiber, and J. Tomko, *Annalen*, 1967, **707**, 203.

³⁷ K. Schreiber and G. Adam, *Tetrahedron*, 1964, **20**, 1707.

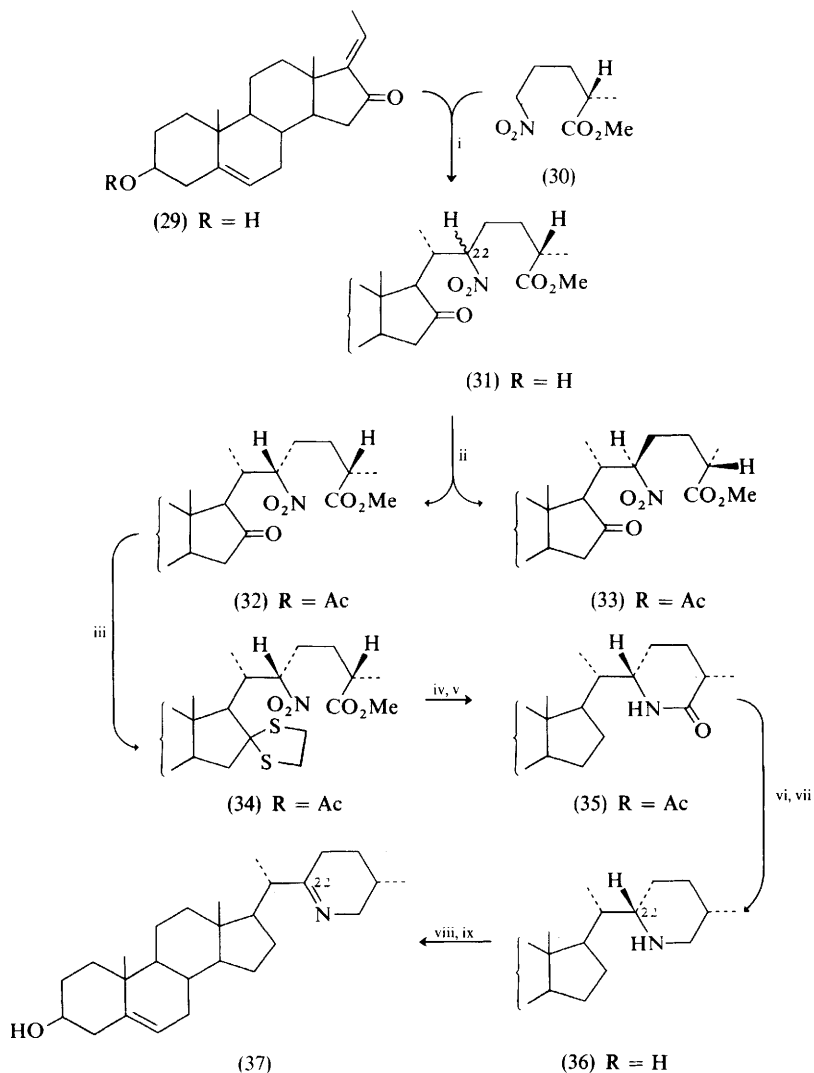

Reagents: i, KOBU^t ; ii, $\text{Ac}_2\text{O-py}$; iii, ethanedithiol-HCl; iv, Zn-AcOH ; v, Raney nickel; vi, $\text{K}_2\text{CO}_3\text{-MeOH}$; vii, LiAlH_4 ; viii, *N*-chlorosuccinimide; ix, NaOMe .

Scheme 1

A possible synthesis of verticine (38) from hecogenin *via* (39) and (40) has been outlined.³⁸

Certain esters of germinine (41) and related compounds are solvolysed under remarkably mild conditions.³⁹ It was earlier observed⁴⁰ that mild hydrolysis of

³⁸ C. C. Fortes, *Diss. Abs. Internat. (B)*, 1974, **35**, 2654.

³⁹ S. M. Kupchan and A. W. By, in ref. 3, p. 193.

⁴⁰ E. M. Cohen and R. Aczel, *J. Pharm. Sci.*, 1971, **60**, 193.

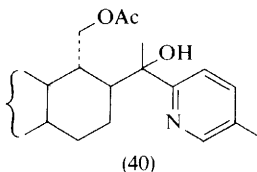
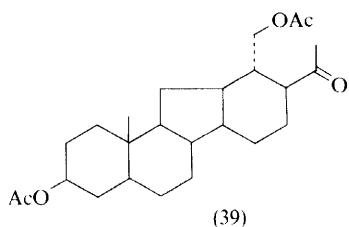
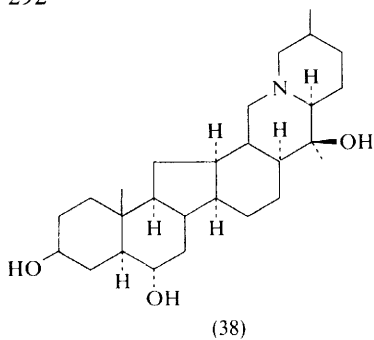

germine-3,16-diacetate (42) gave principally germine-3-acetate and an unidentified diacetate. The latter has now been identified as germine-3,15-diacetate (43) by spectroscopic evidence together with the observations that the new diacetate was inert to sodium metaperiodate but gave germine-3,7,15,16-tetra-acetate (44) on

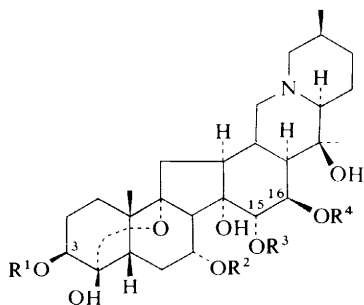

- (41) $R^1 = R^2 = R^3 = R^4 = H$
 (42) $R^1 = R^4 = Ac, R^2 = R^3 = H$
 (43) $R^1 = R^3 = Ac, R^2 = R^4 = H$
 (44) $R^1 = R^2 = R^3 = R^4 = Ac$

acetylation.⁴¹ Germine-3,15-diacetate was further hydrolysed under the same mild conditions⁴¹ to give germine-3-acetate, germine, and an unidentified compound, possibly germine-15-acetate. Presumably germine-3,15-diacetate arises from the 3,16-diacetate by means of a base-catalysed acetyl migration. Such a process may be important in future speculation on the mechanism of the facile solvolysis of germine-16-esters.^{42,43} The variation of melting points of some derivatives of *Veratrum* alkaloids has been studied.⁴⁴

⁴¹ E. M. Cohen, R. Aczel, M. L. Torchiana, R. Tull, and E. J. J. Grabowskii, *J. Medicin. Chem.*, 1974, **17**, 769.

⁴² S. M. Kupchan and A. W. By, in ref. 3, pp. 251–261.

⁴³ S. M. Kupchan, S. P. Eriksen, and Y. T. S. Liang, *J. Amer. Chem. Soc.*, 1966, **88**, 347.

⁴⁴ N. V. Bondarenko, A. L. Shinkarpenko, and G. I. Gerashchenko, *Legk. Promst. Resp. Mezhved. Sb.*, 1973, 186 (*Chem. Abs.* 1974, **81**, 152 483).

Several new *Veratrum* alkaloids have been reported.⁴⁵⁻⁴⁷ Roots of *V. grandiflorum* yielded the new alkaloid veratrenone (45) together with rubijervine, 11-deoxojervine, veratramine, and veratrolyzygadenine.⁴⁵ The structure and absolute stereochemistry of veratrenone were established principally by single-crystal X-ray analysis of the derived hydrobromide. Veratrenone formed a monoacetate (46), which was reconverted into the parent alcohol simply by trituration with

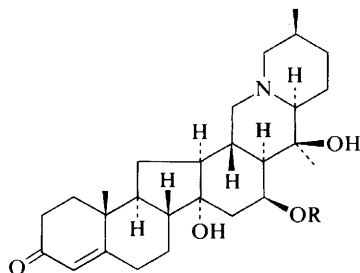

(45) R = H
(46) R = Ac

aqueous methanol. This facile solvolysis, which is typical of 16 β -acetates of this skeletal type,⁴³ has been referred to above. Veratrenone represents a structural type intermediate between the relatively simple *Fritillaria* alkaloids with a cevanine skeleton and the more highly oxygenated ceveratrum alkaloids.^{29,39}

The new alkaloid hakurirodine (C₂₇H₄₃NO₃) has been isolated from acid-hydrolysed extracts of rhizomes of budding *V. grandiflorum*.⁴⁶ Structure (47) was suggested for this alkaloid from the results of chemical and spectroscopic studies which closely parallel those described for the related compound etioline (48)⁴⁸ and

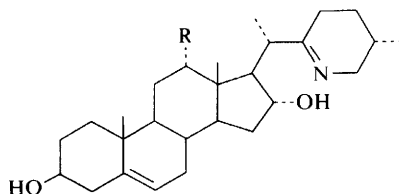

(47) R = OH
(48) R = H

will not be further elaborated here.⁴⁹ The C-12 hydroxy-group of hakurirodine was assigned the α configuration since the C-12 proton was coupled equally (J 2 Hz) to both of the C-11 protons.⁴⁶ Useful confirmation of the main structural features and stereochemistry of hakurirodine was obtained by its conversion⁵⁰ into the solanidane

⁴⁵ M. Takasugi, V. H. Castro-Araya, T. Masamune, A. Furusaki, and T. Matsumoto, *Chem. Letters*, 1974, 1477.

⁴⁶ K. Kaneko, H. Seto, C. Motoki, and H. Mitsuhashi, *Phytochemistry*, 1975, **14**, 1295.

⁴⁷ A. Vassová and J. Tomko, *Coll. Czech. Chem. Comm.*, 1975, **40**, 695.

⁴⁸ K. Kaneko, M. Watanabe, Y. Kawakoshi, and H. Mitsuhashi, *Tetrahedron Letters*, 1971, 4251.

⁴⁹ Cf. R. B. Herbert, in ref. 1a, pp. 293-294.

⁵⁰ Cf. K. Schreiber, C. Horstmann, and G. Adam, *Chem. Ber.*, 1964, **97**, 2368.

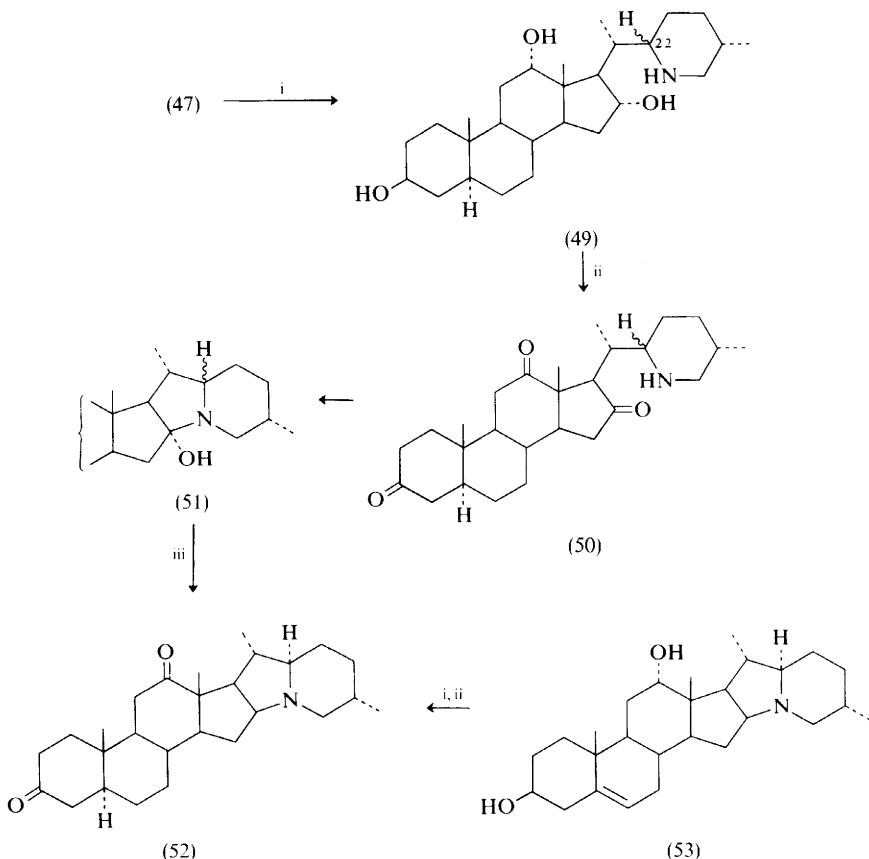

Reagents: i, $\text{PtO}_2\text{-H}_2$; ii, CrO_3 ; iii, Pd/C-H_2 .

Scheme 2

derivative (52) (Scheme 2). Thus the C-22 epimeric mixture of tetrahydroakurirodines (49) was oxidized and the product (51), possibly formed *via* triketone (50), was catalytically reduced.⁴⁶ The resulting diketone, isolated in low yield, was identical with diketone (52) derived from rubijervine (53).⁴⁶

Aerial parts of *V. album* subspecies *lobelianum* furnished a new alkaloid ($\text{C}_{26}\text{H}_{39}\text{NO}$),⁴⁷ together with the previously reported constituents veratroylzygadenine and veracintine (54).⁵¹ The new alkaloid was assigned structure (55) from consideration of the following evidence.⁴⁷ The mass spectrum of the new compound had its base peak at m/e 82 ($\text{C}_5\text{H}_8\text{N}$), corresponding to cleavage of the C-20(22) bond (*cf.* veracintine⁵¹). Confirmation of the postulated side-chain structure was provided by significant peaks at m/e 83 ($\text{C}_5\text{H}_9\text{N}$) and 110 ($\text{C}_7\text{H}_{12}\text{N}$). The i.r.

⁵¹ J. Tomko, V. Brázdová, and Z. Votický, *Tetrahedron Letters*, 1971, 3041; R. B. Herbert, in ref. 1a, pp. 294—295.

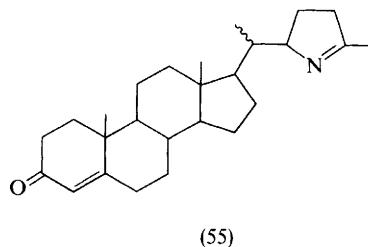
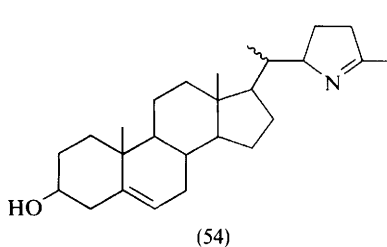

spectrum displayed evidence for an azomethine double bond (1650 cm^{-1}) and an $\alpha\beta$ -unsaturated ketone (1680 cm^{-1}), confirmed by the u.v. spectrum ($\lambda_{\text{max}} 240\text{ nm}$). The n.m.r. spectrum showed appropriate methyl resonances; a one-proton multiplet at 5.9τ and a singlet at 4.32τ were assigned to the C-22 and C-4 protons, respectively. Correlation of the new alkaloid with veracintine confirmed its structure: sodium borohydride reduction of the alkaloid gave, in low yield, a hexahydro-derivative which was identical with a tetrahydroveracintine.^{47,51} Oppenauer oxidation of veracintine (54) gave an enone (55) which was identical with the new alkaloid.⁴⁷

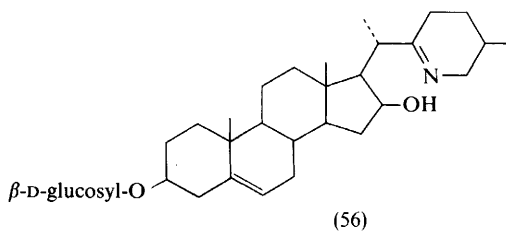

Rubijervine (53) has been isolated for the first time from *V. californicum*.⁵² Deacetylveralosine (56) was isolated from aerial parts of *V. album* subspecies *lobelianum*⁵³ together with the known constituents veralodine⁵⁴ and germine.

⁵² R. F. Keeler, *Phytochemistry*, 1974, **13**, 2336.

⁵³ K. A. Ubaidullaev, R. Shakirov, and S. Yu. Yunusov, *Khim. prirod. Soedinenii*, 1974, 678 (*Chem. Abs.* 1975, **82**, 83 021).

⁵⁴ K. Samikov, R. Shakirov, and S. Yu. Yunusov, *Khim. prirod. Soedinenii*, 1972, 770 (*Chem. Abs.*, 1973, **78**, 108 218).

Erratum

Volume 5, 1975

Page 107, line 15. The correct structure of halfordamine (see also Volume 4, pp. 121, 122) is:

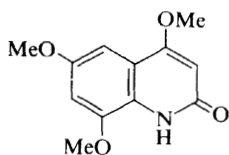

Author Index

- Abdullaev, U. A., 79, 82, 83, 84
Abdullaeva, Kh. A., 103
Abdusalanov, B. A., 7
Abdusanatov, A., 172
Abe, K., 153
Abe, M., 31
Aberhart, D. J., 49
Abidi, Sh., 68
Aboul Enein, H. Y., 284
Abraham, D. J., 221, 235, 247
Abraham, E. P., 49
Abrarov, O. A., 117
Achari, B., 111
Acheson, R. M., 190
Achmatowicz, O., jun., 258
Aczel, R., 291, 292
Adam, G., 290, 293
Adams, R., 77
Adamski, R., 137
Adanin, V. M., 193
Adil, G. A., 77
Adler, F. L., 137
Adler, H. J., 137
Afzali, A., 168
Agar, T. H., 65
Agarwal, S. K., 201
Agurell, S., 15, 31, 32, 119
Agwada, V. C., 220
Ahaman, V. U., 54
Ahmad, A. K. S., 115
Ahmed, F. R., 138
Ahond, A., 143, 209, 227, 247
Aimi, N., 192, 223, 249
Akasu, M., 120, 170
Akbarov, Z. S., 169
Akhmedzhanova, V. I., 103
Akimoto, H., 192
Akiyama, T., 197
Albonico, S. M., 103, 174, 183, 186
Aldous, F. A. B., 117
Aleem, M. A., 177
Alekseeva, L. M., 285
Algeri, S., 128
Aliiev, A. M., 282
Aliiev, Kh. U., 169
Allen, C. M., jun., 29, 196
Allen, J. R., 84, 85
Allinger, D. W., 140
Allinger, W. L., 137
Altenkirk, B., 253, 254
Alworth, W. L., 2
Amico, V., 41
Amiya, T., 265
Amjad Ali, M., 77
Amoros, L. G., 152
Amschler, U., 69
Anderson, D. R., 50
Anderson, J. A., 32, 201
Anderson, J. D., 191
Ando, Y., 172
Andreeva, L. G., 288
Andrianov, V. G., 235, 260
Andronescu, E., 148
Andryauskas, S., 138
Angel, C. R., 137, 138
Anenot, L., 208, 221
Anisimova, O. S., 285
Antonescu, V., 138
Aoki, K., 217
Arata, Y., 96, 97
Aratani, M., 58
Arcamone, F., 31
Archer, S., 70
Arnett, J. F., 58
Arnstein, H. R. V., 49
Arroyo, V., 12
Asai, S., 123, 172
Asgharian, R., 132
Aslanov, Kh. A., 7, 90, 92, 94, 116, 170
Aslanov, S. M., 288
Atal, C. K., 72, 78, 80, 85
Atkinson, M., 117
Atta-ur-Rahman, 249
Au, T. Y., 205
Auer, E., 95
Awaya, J., 54
Ayer, W. A., 253, 254, 255
Aynehchi, Y., 131
Aynilian, G. H., 189, 204, 221, 235
Ayum, T. S. K., 167
Babin, D. R., 258
Bach, N. J., 201
Bacon, C. W., 200
Badauta-Tocan, A., 90
Badiei, S. E., 7
Baerheim, S. A., 111
Baeumber, J., 137
Bailey, H. E., 103
Bailey, V. L., 103
Baily, K., 115
Bajwa, R. S., 32, 201
Baker, K. M., 128
Balakrishnan, P., 151
Balanson, R. D., 100
Baldas, J., 38
Bale, N. M., 12
Balgir, B. S., 267
Ballav, R., 108, 113
Ban, Y., 192, 238
Bandaranayake, W. M., 109
Banerjee, S. K., 200, 289
Banerji, A., 189, 203
Banerji, J., 189, 209
Banning, M. E., 138
Baralle, F., 182
Baranova, Yu. V., 174
Barass, B. C., 117
Bardin, J., 127
Barger, G., 66
Barker, A. C., 29
Barnes, A. J., 246, 247
Barr, J. G., 33
Barrow, K. D., 201
Barry, E., 16
Barton, D. H. R., 20, 21, 22, 25, 116
Bartsch, H., 132
Basa, S. C., 108
Basey, K., 11
Basha, A., 54
Basmadjian, G. P., 31
Bassett, R. A., 31
Basu, D., 103
Battersby, A. R., 18, 19, 21, 22, 26, 29, 30, 33, 35, 39, 139, 140, 144, 147
Beach, D. J., 138
Beal, J. L., 120, 165, 174
Beames, D. J., 267
Beasley, T. H., 137
Beaulieu, T., 85
Beaven, V., 42

- Beck, J., 249
 Beck, M. T., 117
 Becker, J. Y., 132
 Beckett, A. H., 115, 205
 Bockstead, H. O., 115
 Beeman, L. E., 139
 Begley, M. J., 109
 Bell, C. L., 152, 221
 Bell, M. R., 70
 Belleau, B., 134, 138
 Belletini, A. G., 68
 Bellino, A., 105, 107
 Belohlav, L., 183
 Benages, I. A., 103, 174
 Benešová, V., 190
 Benington, F., 192
 Benn, M. H., 13, 281
 Bennett, R. D., 53
 Bentley, R., 47
 Benz, G., 251
 Berenger, G., 282
 Beresford, P. J., 11, 65
 Bergthaller, P., 183
 Bernardi, L., 201
 Berney, D., 122
 Bernstein, H. I., 5
 Besemer, D., 71
 Besselièvre, R., 229
 Bessonova, I. A., 103
 Bevelle, C., 152
 Beynon, P. J., 47
 Bezanson, G. S., 45
 Bhakuni, D. S., 19, 20, 21, 124, 166
 Bhatnagar, S. P., 200
 Bhattacharya, S. K., 111
 Bhavsar, G. C., 10
 Bick, I. R. C., 62, 167, 168, 172
 Bickelhaupt, F., 258
 Binder, M., 44
 Bingel, A. S., 140
 Binks, R., 19
 Birch, A. J., 38, 42, 121, 125
 Bircher, B. J., 144
 Birnbaum, G. I., 80
 Bisset, N. G., 202, 205, 225, 226
 Bite, P., 289
 Bjorklund, A., 114
 Blackstock, W. P., 33
 Bláha, K., 224, 243
 Blaschke, G., 23
 Bloch, K., 16
 Blomster, R. N., 247
 Blosssey, E. C., 65
 Blum, K., 137
 Blumberg, H., 136
 Boar, R. B., 25
 Boca, J. P., 258
 Bodanszky, M., 12
 Bodem, G. B., 193
 Bőjthe-Horváth, K., 207, 220
 Bognar, R., 136, 137
 Bogri, T., 258
 Bohlmann, F., 91
 Boiois, M. L., 290
 Boit, H.-G., 183
 Bombardelli, E., 233, 234, 247
 Bonasera, N., 8
 Bonati, A., 233, 234, 247
 Bonavita, V., 8
 Bondarenko, N. V., 292
 Borer, R., 176
 Borgman, R. J., 177, 178
 Bosly, J., 226
 Bottini, A. T., 68
 Bouquet, A., 232
 Boulton, A. A., 115
 Bourdoux, P., 254
 Bourgeois, J., 90
 Bourgooin, A., 62
 Bourillet, F., 128
 Bowden, B. F., 103
 Bowen, D. V., 136
 Bowman, R. M., 108
 Boyce, C. B., 96
 Boyd, D. R., 107
 Bracho, R. D., 25, 116
 Bradbury, R. B., 139
 Bradley, C. H., 49
 Braekman, J. C., 99, 254
 Brandänge, S., 72
 Brannon, D. R., 235, 251
 Bratek-Wiewiórska, M. D., 91, 92
 Brattesani, D. N., 55
 Braunstein, J. D., 10
 Brázdová, V., 294
 Bremner, J. B., 62
 Breuer, E., 54
 Brewer, H. W., 258
 Brewster, K., 117
 Briner, R. C., 96
 Broich, J. R., 138
 Brossi, A., 122, 176
 Brown, B. O., 109
 Brown, E., 62
 Brown, G., 58
 Brown, H., 128
 Brown, L. D., 138
 Brown, P., 233
 Brown, R. T., 33, 34, 209, 213, 214, 215, 244
 Brown, V. H., 136
 Browner, L. M., 255
 Bruderer, H., 122
 Bruneton, J., 58, 232, 233
 Buchanan, J. M., 8
 Buchanan, R. L., 123
 Buck, K. T., 187
 Budd, R. D., 115
 Budzikiewicz, H., 65
 Büchi, G., 198, 235
 Buffa, B., 171
 Bujtas, G., 128
 Bull, L. B., 76
 Bu'lock, J. D., 33, 37
 Burke, D. E., 226
 Burke, M. D., 137
 Burnell, R. H., 203, 253
 Burnett, A. R., 33
 Burns, D. A., 137
 Busetta, B., 229
 Buxton, D. A., 117
 Buzas, A., 128
 By, A. W., 291, 292
 Bycroft, B. W., 49
 Byerrum, R. U., 8, 12, 14
 Bylsma, F., 249
 Calvert, B. J., 68
 Calvo, C., 254
 Cameron, A. F., 196
 Cameron, D. W., 42
 Campbell, I. M., 47
 Cannon, J. G., 177
 Canonica, L., 171
 Cardillo, R., 196
 Carpenter, T. C., 68
 Carroll, F. I., 136, 243
 Carstens, L. A., 84
 Carter, J. C., 228
 Cartz, L., 229
 Carver, R. A., 57
 Casadio, S., 69
 Casagrande, C., 171
 Cashaw, J. L., 128
 Casnati, G., 30
 Cassels, B. K., 103, 174
 Castaldi Spinelli, A., 91
 Castedo, L., 92, 182, 183
 Castenson, R. L., 181
 Castille, M., 254
 Castillo, M., 23
 Castro-Araya, V. H., 293
 Casy, A. F., 70
 Catlin, D. H., 138
 Cava, M. P., 76, 165, 167, 168, 174, 187, 202
 Cavalli, A., 117
 Cavé, A., 58, 103, 108, 117, 154, 165, 173, 182, 192, 207, 208, 232, 233
 Cedola, M., 184
 Černý, V., 284, 287
 Červinka, O., 76
 Chain, E. B., 31
 Chakrabarty, M., 111, 203
 Chakraborty, D. P., 190
 Chanda, T. K., 246
 Chandrasekharan, S., 261
 Chang, C., 41
 Chang, C. J., 42
 Chankan, P. S., 108
 Chao, J. M., 200
 Chapelle, A., 203
 Chapman, G. M., 21
 Chapple, C. L., 34, 213, 214, 215
 Charalambides, A. A., 209, 213
 Chardon-Loriaux, I., 242

- Charles, R. L., 137
 Charnock, G. A., 120
 Charteris, A., 115
 Chastain, R. V., jun., 67
 Chatterjee, A., 111, 189, 232
 Chatterjee, N., 136
 Chauhan, P. S., 113
 Chaykin, S., 8
 Checklov, A. N., 93
 Chedekel, M. R., 13, 193
 Chen, C.-M., 123
 Chen, C. R., 120, 174
 Chen, S.-M. L., 117
 Chen, T.-K., 136
 Chen, Y. K., 197
 Chen, Y.-P., 110
 Cheng, C. C., 148
 Cheng, M., 32
 Cherkez, S., 67
 Cherry, P. C., 229
 Cheung, H. T., 205
 Chibata, I., 12
 Chidgey, R., 67
 Chikamatsu, H., 181
 Chilingarov, A. O., 115
 Chin, C. G., 253
 Chirita, L., 140
 Cho, E., 200
 Cho, Y. D., 7
 Cholakova, I., 148
 Chopra, R. N., 65
 Chowdhury, B. K., 117
 Christensen, J. C., 136
 Christian, S. T., 192
 Christman, D. R., 2
 Chu, J. Y.-R., 49
 Churacek, J., 111
 Cionga, E., 140
 Clara, R. A., 123
 Clardy, J., 197, 198, 233, 249
 Clarke, D. D., 136
 Clarke, D. G., 109
 Clarke, P. A., 137
 Clarke, R. L., 69
 Clauder, O., 196, 207, 220, 229
 Clayton, R. B., 53
 Cleaver, L., 103
 Clements, J. H., 29
 Cleriot, M. O., 108
 Cloyd, J. C., 46
 Coates, J. E., 70
 Cochran, T. G., 138
 Coetzer, J., 196
 Coffen, D. L., 240
 Cohen, E. M., 291, 292
 Cohen, G., 122
 Cohen, T., 20
 Cohylakis, D., 241
 Cole, R. J., 197, 198, 199
 Cole, W. J., 137
 Colella, D. F., 117
 Coleman, G. L., 169
 Collins, J. F., 39, 40
 Comer, F., 185
 Cone, E. J., 136
 Connert, J., 56
 Conway, T., 134, 138
 Cook, G. A., 226, 233
 Cook, J. M., 226, 233, 249
 Cook, M. R., 178
 Cookson, R. C., 265
 Coon, M. J., 16
 Cooper, M. J., 67
 Cooper, S. F., 111
 Copeland, E. S., 137
 Corbella, A., 55
 Corbett, K., 31, 49
 Corbier, B., 63
 Cordell, G. A., 35, 140, 235
 Corey, E. J., 58, 62, 97, 100
 Cornforth, J. W., 25
 Correa, D. de B., 62
 Corrodi, H., 178
 Cory, M. J., 136
 Coscia, C. J., 18, 125, 170
 Cosson, J. P., 247, 249
 Costa, G., 171
 Coumbis, R. J., 137
 Counsell, R. E., 283
 Courseille, C., 229
 Court, W. E., 203
 Coussio, J. D., 191
 Coutts, R. T., 184
 Cowell, D. B., 272
 Crabb, T. A., 122
 Craig, L. C., 258
 Crane, F. A., 140, 235
 Crawhall, J. C., 49
 Creedon, P. B., 5
 Crenshaw, R. R., 123
 Cretney, W. J., 249
 Crohare, R., 184
 Crombie, L., 109
 Croquelois, G., 230, 239
 Cross, A. D., 152
 Crout, D. H. G., 11, 12, 13, 72, 76, 83
 Cryer, P. E., 114
 Culvenor, C. C. J., 72, 75, 76, 80, 189, 192
 Curtain, C. C., 85
 Cushley, R. J., 50
 Dabra, T. T., 167
 Daddona, P. E., 35, 36, 244
 Dafeldecker, W. P., 178
 Dahlstrom, B., 137
 Dahya, M. S., 137
 Dale, D. C., 140
 Daloz, D., 99
 Daly, J. W., 58
 Dane, E., 3
 Danieli, B., 195, 233, 234, 247
 Darmory, F. P., 238
 da Roche, A. I., 167, 187
 Das, B. C., 226, 227, 232, 249
 Das, K. C., 94, 95
 Dasgupta, B., 141
 Das Gupta, V., 71
 Daum, S. J., 69
 Dave, K. G., 36
 David, A., 128
 Davidovitch, Yu. A., 117
 Davies, J. S., 12
 Davies, N. M., 11, 12
 Davis, A. K., 272
 Davis, B. D., 47
 Davis, J. I., 137
 Davis, V. E., 128
 Dawson, R. F., 2
 Dayton, A. B., 136
 De, K. K., 140
 Deak, G., 121
 De Bernardo, S. L., 114
 Debnath, P. K., 111
 Debray, M., 90, 165
 Debray, M. M., 204, 220, 222, 242
 De Budowski, J., 192
 De Camp, W. H., 258
 Decadain, N., 103, 154
 Decsi, L., 230
 De Graeve, N., 148
 De Graw, J. I., 136
 De Jongh, D. C., 165
 de Juarez, M. E. A., 103, 174
 Delabos, C., 90
 De La Camp, U. O., 68
 De La Higuera, N., 49
 Delaveau, P., 205
 Delle Monache, E. M., 221
 Demain, A. L., 198
 de Mairville, M. D., 224
 Demina, L. G., 81
 Demole, C., 63
 Demole, E., 63
 Deneva, T., 131
 de Nicola, M. G., 41
 Der Marderosian, A., 200
 Desai, H. K., 117
 De Silva, K. T. D., 33
 De Silva, S. O., 161
 Deulofeu, V., 183, 186
 de Zorzi, C., 117
 Dhar, M. M., 166, 288
 Dhar, N. C., 127, 148
 Dhawan, B. N., 171
 Diatta, L., 235
 Diaz Chico, E., 103
 Dick, A. T., 76
 Dideberg, O., 208
 Di Gregoro, G. J., 137
 Dikko, S., 254
 Dimitrov, I., 131
 Dinarello, C. A., 140
 Dinda, B. N., 220, 232, 246
 Di Pardo, R. M., 101
 Djarmati, Z., 258
 Djerassi, C., 59, 65, 234

- Dmitrienko, G. I., 220
 Dobbins, M. F., 114
 Doctor, B. P., 138
 Doedens, D. J., 137
 Döpke, W., 221
 Doganca, S., 75
 Doguc, T., 90
 Dolejš, L., 124, 152, 154, 170, 171
 Dolfini, J. E., 238
 Dolinger, P. M., 59
 Donachie, F., 111
 Donetti, A., 69
 Donnelly, W. J., 39, 40
 Doorenbos, N. J., 131, 284
 Dapp, R., 113
 Dóra-Horváth, K., 196
 Doskotch, R. W., 120, 165, 174, 183
 dos Santos Fiho, D., 191
 Dossena, A., 196
 Douglas, B., 76, 174, 212
 Douzoua, L., 204
 Dowda, D. S. S., 229
 Draffan, G. H., 123
 Dreiding, A. S., 26, 41
 Dreyer, D. L., 105
 Drost-Karbrowska, K., 148
 Dube, P. H., 128
 Dubey, M. P., 171
 Dúbravková, L., 221
 Duchamp, D. J., 114
 Duchevska, K. H. B., 173
 Ducruix, A., 247
 Dugal, R., 111
 Dunathan, H. C., 5
 Dunkelblum, E., 41
 Dunkerton, L. V., 58
 Dupont, L., 208
 Durden, D. A., 115
 Duret, C., 227
 Durham, L. J., 234
 Dutky, S. R., 191
 Dutta, L. N., 182
 Dutta, S. C., 204
 Dwuma-Badu, D., 131, 166, 167, 170
 Dyke, S. GF., 126, 144

 Earle, W. H., 119
 Ebizuka, Y., 40
 Eckhardt, G., 120, 175
 Edgar, J. A., 75, 80
 Edire, D. L., 167
 Edwards, J. M., 97
 Edwards, O. E., 258, 265
 Eggert, J. H., 46
 Egnell, C., 128
 Ehmann, A., 191
 Ehrenfeld, E. R., 8
 Eickman, N., 197
 Eisner, T., 54
 El-Alfy, T. S., 163
 El Azzouny, A., 38

 El-Fataty, H. M., 115
 El Kheir, Y., 110, 131
 Ellestad, G. A., 199
 El Nouri, S., 154
 Enchev, E. M., 148
 Engelmann, K., 220
 Erdtman, H., 20
 Erge, D., 31
 Erhardt, P. W., 179
 Eriksen, S. P., 292
 Esmailzadah, A., 137
 Essenbreis, H., 56
 Esser, F., 113
 Essien, C. D., 110
 Estadiou, M., 137
 Estevez Reyes, R., 103
 Evans, W. C., 10, 65, 66

 Fairburn, J. W., 131, 132
 Fales, H. M., 16
 Farcilli, A., 171
 Farina, E., 114
 Farina, M., 184
 Farnsworth, N. R., 110, 140, 152, 189, 203, 204, 221, 235, 247
 Faugeras, G., 90
 Fawcett, P., 49
 Favez, M. B. E., 16
 Fayos, J., 198, 233, 249
 Fejér-Kossey, O., 14
 Feller, D. R., 127
 Fenselay, C., 70, 137
 Ferrari, F., 192
 Ferreira, M. A., 192
 Ferreira, N. P., 30
 Ferri, V., 116
 Ferris, J. P., 96
 Field, F. H., 136
 Fierz, G., 67
 Finyakin, L. N., 285
 Fischer, A. G., 15
 Fischer, N., 26
 Fischer, R., 32
 Fischer, Th., 68
 Fish, F., 111
 Fischman, J., 136
 Fitch, W. L., 59
 Fitzgerald, T. J., 140
 Floss, H. G., 28, 31, 32
 Focella, A., 122
 Fodor, G., 65, 66, 67, 68
 Foley, M. H., 12
 Foltz, R. L., 137
 Fong, H. H. S., 140, 152
 Fonzes, L., 258
 Forde, E., 3
 Forney, R. B., 137
 Forrest, J. E., 116
 Forrest, T. P., 116
 Fortes, C. C., 291
 Foster, L. L., 115
 Foucher, J. P., 117

 Foy, J. E., 120
 Frahn, J. L., 75, 192
 Framm, J., 38
 Francis, R. J., 19, 22, 147
 Frankenburg, W. G., 14
 Fraser, S. B., 209, 244
 Freer, A. A., 196
 Frehel, D., 67
 French, C. J., 41
 Frigerio, A., 128
 Fritzberg, A., 49
 Fröstl, W., 59
 Fry, D. E., 137
 Fürst, S., 139
 Fuganti, C., 15, 30, 39, 144, 196
 Fujii, K., 249
 Fujii, T., 162, 163
 Fujimaki, M., 122
 Fujimoto, H., 197
 Fujimoto, J. M., 136
 Fujimura, H., 138
 Fujioka, M., 174
 Fujita, K., 113
 Fujita, M., 120, 170
 Fujita, R., 96
 Fujita, T., 70
 Fujiwara, T., 153, 253
 Fukuda, D. S., 235
 Fukudome, J., 217
 Fukumoto, F., 147, 175
 Fukumoto, K., 111, 132, 144, 145, 146, 157, 159, 162, 171, 189, 213, 246
 Fukuyana, T., 58
 Fukazawa, Y., 253, 254
 Fuller, G. B., 229
 Funderburk, M. J., 173
 Furukawa, H., 124, 129
 Furusaki, A., 293
 Furuya, T., 76, 131, 175
 Fuxe, K., 178

 Gaal, G., 136, 137
 Gabetta, B., 233, 234, 247
 Gadiant, F., 69
 Gafner, G., 199
 Gafni, J., 140
 Gairola, C., 42
 Gal, J., 68
 Galeffi, C., 221
 Gall-Istok, K., 121
 Gallo, G. G., 47
 Gandhi, S. S., 290
 Gandini, E., 201
 Ganzinger, D., 280
 Garattini, S., 128
 Garbarczyk, J., 92
 Gardini, G. P., 30
 Gariboldi, P., 55
 Gasic, O., 154
 Gates, M., 134
 Gatti, G., 196
 Gawad, D. H., 190
 Gawroski, J., 91

- Geary, P., 3
 Geissman, T. A., 13
 Genenah, A. A., 123
 Genius, O., 71
 Genkina, N. K., 285
 George, V., 289
 Georgiev, S., 131
 Georgiev, V. St., 156
 Gerashchenko, G. I., 292
 Gerashimenko, I. I., 289
 Gerecke, M., 176
 Ghani, G., 66
 Ghirardi, P., 171
 Ghiringhelli, D., 196
 Gholson, R. K., 7, 8
 Ghosal, S., 108, 111, 113, 141, 191
 Ghosh, M. N., 85
 Giacopello, D., 182
 Gianturco, M., 77
 Gibson, C. A., 8
 Gieren, A., 68
 Gilbert, B., 191
 Gilbertson, T. J., 17
 Gillard, J. W., 62
 Gillespie, J. P., 128, 152.
 Gilot-Delhalle, J., 148
 Gitsov, L., 148
 Gleye, J., 143
 Glinsuken, T., 198
 Goepel, C. R., 165
 Gössinger, E., 183
 Goina, T., 148
 Goldbaum, L. R., 137
 Goldfinger, S. E., 140
 Goldner, S. J., 138
 Golub, E. E., 42
 Goma, C. S., 115
 Gonord, P., 227
 Gonzalez, A. G., 103
 Gonzalez, C., 124
 Gooden, E. L., 67
 Goodwin, B. L., 123
 Gopinath, K. W., 172
 Gordon-Gray, C. G., 73
 Gorecki, P., 185
 Gorman, M., 235, 247
 Gorodetzky, C. W., 138
 Goryaev, M. I., 285, 286, 287
 Gosh, N. N., 65
 Gotoh, M., 153
 Gottlieb, O. R., 62
 Gourdet, G., 138
 Gourdier, B., 239
 Goutarel, R., 230
 Govindachari, T. R., 88, 89, 117
 Govyrin, V. A., 117
 Grabowskii, E. J. J., 292
 Graf, W., 45
 Grahl-Nielsen, O., 114
 Granchelli, F. E., 175, 178
 Granelii, I., 15, 119
 Grasselli, P., 196
 Gray, A. I., 111
 Graziano, M. N., 191
 Green, D. M., 117
 Greenhouse, R., 229
 Gribble, G. W., 193
 Grierson, D. S., 229
 Griffith, G. D., 14
 Griffith, T., 14
 Grigg, M. A., 12
 Grigorescu, E., 200
 Grilla, E. J., 169
 Gröger, D., 31, 201
 Groeningsson, K., 71
 Groß, D., 2, 8, 33
 Grossmann, E., 209
 Grundon, M. F., 39, 40, 103, 107, 108
 Grutzner, J. B., 28
 Gubina, T. N., 68
 Guevara, M. C., 289
 Guilhem, J., 247, 282
 Guinaudeau, P. H., 165
 Gunatilaka, A. A. L., 116
 Gupta, D., 206
 Gupta, R. N., 3, 17
 Gupta, Y. P., 290
 Guseva, A. R., 53
 Gut, M., 280
 Guttman, D. E., 128
 Gyarmati, L., 128
 Habib, A. M., 80
 Habib, M. S., 163, 203
 Hadwiger, L. A., 7, 8
 Haga, S., 163
 Hagaman, E., 36, 244
 Hager, H., 137
 Haginiwa, J., 120, 192, 202, 223, 249
 Hahn, E. F., 136
 Haisova, K., 143
 Hakin, F., 131
 Hall, E. S., 33
 Hall, O., 131
 Hallak, N., 73
 Haller, K. G., 226
 Ham, N. S., 192
 Hamilton, H. E., 137
 Hamonnière, M., 173
 Hanaoka, M., 96, 97
 Handa, S. S., 66
 Handler, P., 8
 Hanke, M. E., 2
 Hansen, P. E., 122
 Hanson, K. R., 53
 Hanus, V., 152
 Hara, H., 175
 Harada, K., 151, 152
 Harayama, T., 252, 253
 Hardy, A. D., 138
 Harmon, R. E., 140, 180
 Harrison, D. M., 39, 40, 103
 Hart, N. K., 21
 Hartley, D., 117
 Haruna, H., 124
 Harwig, J., 197
 Hasegawa, M., 181
 Hashimoto, K., 69, 174
 Hassall, C. H., 12
 Hatakeyama, Y., 131
 Hattori, S., 123, 141
 Hauser, F. M., 136
 Hauth, H., 199, 240
 Havel, M., 287
 Haynes, L. J., 21
 Hazai, L., 121
 Heacock, R. A., 116
 Heathcock, C. H., 55
 Heckendorf, A. H., 36, 244
 Hedin, P. A., 99
 Heftmann, E., 53, 285
 Hegerova, S., 111, 152
 Hegnauer, R., 110
 Helliwell, K., 132
 Hemingway, S. R., 204, 205, 212
 Henson, R. D., 99
 Herbert, R. B., 1, 2, 5, 6, 7, 8, 11, 15, 16, 17, 20, 23, 25, 26, 29, 30, 31, 32, 33, 35, 37, 38, 39, 40, 41, 42, 45, 47, 49, 50, 52, 139, 285, 286, 293
 Herlem, D., 280, 282
 Herout, V., 190
 Herran, J., 184
 Hesp, B., 196
 Hesse, M., 189, 220, 243
 Hesse, R. H., 22
 Hewett, C. L., 283
 Hibino, S., 159
 Hicks, K., 54
 Higa, T., 103
 Higashi, K., 69
 Higgins, T. N., 138
 Hignett, G. J., 241
 Hiiragi, M., 122, 163
 Hikichi, M., 76
 Hilal, S. H., 163
 Hiles, R. A., 8
 Hino, T., 192
 Hiraga, K., 115
 Hirai, Y., 162
 Hirami, Y., 283
 Hirata, S., 157, 159
 Hirata, Y., 56, 64, 251, 257, 267, 268, 269, 270
 Hirota, T., 121
 Hirst, M., 147
 Hisamoto, T., 70
 Hiutric, A. C., 111
 Ho, Y. K., 45
 Hoang-Nam, N., 272
 Hobson, J. D., 68
 Hodson, H. F., 110
 Hoellinger, H., 272
 Hörhammer, R. B., 97
 Hoffman, D. B., 138

- Hoffmann, H. M. R., 67
 Hofinger, M., 191
 Hohlbrugger, R., 158
 Hoizey, M. J., 222, 242
 Hokawa, H., 120
 Hokimoto, K., 66
 Holland, H. L., 23, 254
 Holloway, D. M., 175
 Holloway, P. W., 42
 Holmstedt, B., 137
 Holtzman, J. L., 137
 Holubek, J., 155
 Holzapfel, C. W., 30, 31
 Honerjäger, P., 290
 Honma, S., 131
 Hooper, P. T., 85
 Hootete, C., 99, 254
 Hoppe, W., 68
 Horan, H., 16
 Hori, K., 223
 Hori, M., 138
 Hori, N., 96
 Horii, Z., 170
 Horita, A., 178
 Hornemann, U., 45, 46
 Horstmann, C., 293
 Horton, H. R., 251
 Horvath, G., 136, 137
 Horwitz, C. A., 137
 Hoshino, O., 120, 121, 175
 Hosoya, K., 120
 Hospital, M., 229
 Hotellier, F., 205
 Houghton, P. J., 36, 205, 212
 Hoyte, D. A. N., 85
 Hruban, L., 111, 152, 159
 Hsu, H. -Y., 110
 Hsu, I. C., 84, 85
 Huang, F.-C., 49
 Hub, L., 76
 Hubert-Brierre, Y., 280
 Huckstep, L. L., 49, 235, 246, 251
 Hufford, C. D., 173
 Hugel, G., 239
 Hulpke, H., 53
 Huls, R., 166, 182
 Hulsizer, J. M., 117
 Hunt, N., 198
 Hurley, L. H., 41, 42
 Hursthouse, M. B., 73
 Hussein, F. T., 140
 Husson, A., 222
 Husson, H. P., 222, 226, 227, 229, 233, 242, 279
 Hutchinson, C. R., 35, 36, 244
 Hylands, P. J., 88
 Hwang, D.-Y., 175
 Ibragimov, Kh. P., 117
 Ibragimova, M. U., 149
 Ibuka, T., 59, 133, 165
 Ichihara, A., 264
 Ichinohe, Y., 263
 Ido, H., 202
 Ihara, M., 144, 146, 147, 157, 159, 160
 Iida, T., 129
 Itaka, Y., 197, 265
 Ikekawa, N., 285
 Ikram, M., 179
 Ikuta, A., 131, 175
 Iliev, L. S., 131
 Il'in, G. S., 2
 Illman, R. J., 192
 Imai, K., 114, 115
 Imaseki, H., 13
 Imori, Y., 174
 Impellizzeri, G., 26
 Inoue, H., 138
 Inoue, S., 58
 Inoue, T., 174
 Inturrisi, C. E., 136
 Inubushi, Y., 59, 133, 165, 252, 253
 Irie, H., 217
 Irikawa, H., 257, 270
 Irishbaev, A., 108
 Irismetov, M. P., 285, 286, 287
 Isaev, I. Ya., 103
 Ishbaev, A. I., 90, 92
 Ishida, T., 151, 152
 Ishii, H., 120, 151, 152, 190, 253
 Ishikawa, S., 12
 Ishikawa, T., 120
 Ishimara, S., 269
 Ishimaru, H., 122, 163
 Ishiwatari, S., 171
 Iskandarov, S., 91
 Ismailov, Z. F., 177, 186
 Isoi, K., 174
 Israelov, I. A., 123, 149
 Itaga, S., 122
 Itakura, K., 171
 Itara, H., 121
 Ithakissios, S. D., 125
 Ito, H., 12
 Ito, K., 123, 124, 129, 172
 Itô, S., 264
 Itoh, I., 229, 233
 Itokawa, H., 170
 Itori, M., 138
 Ivanov, T. N., 81
 Ivanova, R. M., 131
 Iwadore, S., 251
 Iwanow, A., 94
 Iwata, C., 170
 Iwawa, K., 153
 Iyer, K. N., 262
 Jackson, A. H., 120, 121, 125
 Jacobs, W. A., 258
 Jaeggi, K. A., 243
 Jaffarian, S., 131
 Jago, M. V., 85
 Jahodár, L., 202
 Jain, G. C., 137
 Jain, N. C., 115
 James, K. J., 39, 40
 James, R., 25
 Jandera, P., 111
 Jankowski, K., 218
 Jans, B. P., 148
 Janssen, P. A. J., 138
 Jardine, I., 70, 137
 Jarreau, F. X., 191
 Jaswal, S. S., 262
 Jauner, T., 122
 Jeffs, P. W., 141
 Jenks, T. A., 123
 Jehansson, C.-J., 67
 John, R., 115
 Johnne, S., 201
 Johns, N., 37
 Johns, S. R., 21, 65, 100, 181, 190
 Johnson, I. T., 113
 Johnson, R. D., 8
 Johnson, S. W., 267
 Johnston, J. P., 264
 Johnstone, R. A. W., 114
 Jommi, G., 55
 Jonas, A. M., 169
 Jones, C. D., 23
 Jones, J. B., 68
 Jones, R. C. F., 18, 26
 Jones, T. H., 86
 Joo, F., 117
 Joshi, B. C., 138
 Joshi, B. S., 190
 Joshi, P. P., 166
 Joule, J. A., 189, 218, 241
 Ju-ichi, M., 172, 174, 181
 Jukofsky, O., 114
 Jusiak, L., 110
 Kabanov, V. S., 90
 Kador, P. F., 127
 Kadyrov, Ch. Sh., 108
 Kahindo, N., 254
 Kaiser, C., 117
 Kaiser, E. M., 121
 Kajiwara, M., 162, 213
 Kakimoto, S., 263, 264
 Kakoi, H., 58
 Kallos, J., 258
 Kaloy, K., 229
 Kałuski, W., 92, 93
 Kamada, S., 163
 Kamaev, F. G., 94
 Kametani, T., 110, 111, 121, 122, 123, 132, 144, 145, 146, 147, 157, 159, 160, 162, 163, 170, 171, 175, 180, 187, 189, 213, 246
 Kamiewski, T., 147
 Kamigauchi, M., 153
 Kan, S. K., 227
 Kaneko, K., 52, 293

- Kaneshima, H., 115, 131
 Kaneto, H., 137
 Kan-Fan, C., 226, 227, 233
 Kania, B. F., 139
 Kano, S., 126, 130, 147
 Kao, M.-T., 123
 Kapadi, A. H., 258
 Kapadia, G. J., 16, 117
 Kاپil, R. S., 19, 20, 222
 Kaplan, E. R., 115
 Kaplan, N. O., 8
 Kapoor, R., 289
 Kapoor, Y. K., 225
 Kaposi, P., 230, 246
 Karimov, M., 116
 Karlsson, A., 46
 Kartha, G., 117
 Kashman, Y., 67
 Kataoka, K., 153
 Kating, H., 192
 Kato, H., 122
 Kato, M., 139
 Kato, T., 138, 144, 217
 Katonak, D. A., 240
 Katsui, N., 263
 Katz, E., 12, 42
 Kaul, B., 137
 Kaul, B. L., 289
 Kawakoshi, Y., 52, 293
 Kawasaki, T., 197
 Kazlauskas, R., 18, 26
 Keda, B. I., 115
 Keeler, R. F., 295
 Kehr, W., 115
 Kehrler, J. P., 45, 46
 Keiser, J. E., 178
 Kelling, K. L., 6
 Kelsey, J. E., 39
 Kennard, C. H. L., 132
 Kennedy, B. P. C., 197
 Keogh, M. F., 3
 Kerekes, P., 136, 137
 Kessar, S. V., 151, 290
 Khadzhilov, A. I., 148
 Khakimov, O., 66
 Khalil, M. F., 203
 Khalil, S. K. W., 115
 Khalmirzaev, M. M., 205, 211, 220
 Khan, M. A., 274
 Khandelwal, P. K., 138
 Khanna, N. M., 288
 Khasanova, M. A., 79
 Khashimov, Kh. N., 108
 Khatamkulova, G. S., 285
 Khodzhaev, B. U., 282
 Khodzhaev, V. G., 173, 186
 Khonje, P. R., 177
 Khuong-Huu, F., 280, 282
 Khuong-Huu, Q., 273, 280
 Kido, F., 139
 Kiechel, J.-R., 44
 Kigasawa, K., 122, 163
 Kikugawa, Y., 192
 Killion, K., 186
 Kilminster, K. N., 229
 Kim, D. K., 152
 Kim, J. C., 284
 Kimler, L., 41
 King, G. S., 32, 123
 King, S. W., 178
 Kinoshita, Y., 131
 Kinsman, R. G., 126
 Kirby, G. W., 21, 22, 25, 30, 37
 Kirksey, J. W., 197, 198, 199
 Kirkup, M., 68
 Kirven, E. P., 10
 Kiryanova, A. T., 160
 Kasaki, T., 2, 14
 Kiselev, U. U., 139
 Kiseleva, I. D., 117
 Kishi, Y., 58
 Kitagawa, M., 192
 Kitaigorodskii, A. I., 93
 Kitaura, Y., 198
 Kitazawa, M., 98
 Kiuchi, M., 192
 Klásek A., 72, 74, 76, 81, 111, 159, 261
 Klaubert, D. H., 198
 Klimova, L. I., 285
 Klioze, S. S., 238
 Klötzer, W., 156, 158
 Klose, T. R., 267
 Kluender, H., 49
 Kluge, A. F., 54
 Klutch, A., 137
 Klyne, W., 72, 76, 91
 Knabe, J., 128
 Knapp, J. E., 131, 166, 167, 170, 174
 Knöfel, D., 6
 Knoll, J., 139
 Ko, H., 114
 Kobayashi, K., 192
 Kobel, H., 32
 Koblicova, Z., 155, 224, 243
 Koch, M., 210
 Kocienski, P. J., 68
 Kocsis, A., 207, 220
 Kodama, M., 264
 Körösi, J., 103
 Kohler, R.-D., 32
 Kohlmuenger, S., 78
 Koida, M., 137
 Koizumi, H., 147
 Kokrady, S., 180
 Koltai, M., 103
 Komerosova, I., 31
 Kometiani, P. A., 115
 Komiyama, E., 126, 147
 Komiš, I., 209
 Konda, Y., 54
 Kondo, K., 146
 Kondo, M., 138
 Kondo, Y., 146
 Kong, H.-N., 123
 Konoshima, T., 165
 Koontz, S., 71
 Koppelman, R., 2
 Kornfeld, E. C., 201
 Korshak, V. V., 81
 Korzhavikh, E. O., 71
 Koschara, W., 3
 Koslow, S. H., 114
 Kostenbauder, H. B., 128
 Kotani, E., 98
 Kovacs, K., 85
 Kovacs, M. T., 136
 Kovar, J., 148
 Koyama, T., 121
 Kozuka, A., 145
 Kraft, M., 70, 110
 Kramarenko, G. V., 140
 Kramarenko, V. F., 110
 Krauss, D., 56
 Kraybill, H. F., 84
 Kristallovich, E. I., 177
 Kropp, P. J., 86
 Kruger, G. J., 199
 Kubasik, W. P., 138
 Kubo, A., 223, 249
 Kubota, K., 69
 Kucerova, H., 110
 Kucerova, M., 110
 Kugita, H., 138
 Kulkarni, M. R., 289
 Kullberg, M. P., 138
 Kundu, A. B., 111
 Kunesch, N., 103, 154, 222, 239
 Kunitomo, J.-I., 172, 174, 181
 Kunstmann, M. P., 199
 Kupchan, S. M., 183, 291, 292
 Kurakina, I. O., 282
 Kuramoto, M., 192
 Kurata, T., 122
 Kurihara, H., 264
 Kurosawa, Y., 283
 Kutney, J. P., 229, 233, 249
 Kybal, J., 31
 Lafarge, J. P., 137
 Lahti, R. A., 114
 Laing, M., 74
 Lajšić, S. D., 258
 Lakshmikantham, M. V., 165
 Lal, S., 178
 Lalezari, I., 132
 LaLonde, R. T., 94, 95
 Lambertson, J. A., 21, 65, 100, 181, 190
 Lancili, G., 47, 49
 Langlois, N., 229, 234, 235, 247
 Langlois, Y., 224, 229, 235
 Langman, T. A., jun., 8
 Langowska, K., 91
 Lantos, I., 97
 Larson, R. A., 35, 41
 Lartey, P. A., 170
 Lashford, A. G., 215
 Lasskaya, O. E., 154, 160

- Latzel, J., 223
 Lazar, H. A., 226
 Lazurevskii, G. V., 110, 193
 Leander, K., 15, 119
 Lebbe, J., 137
 Lebet, C.-R., 44
 Leboeuf, M., 165, 173, 182
 Ledouble, G., 222
 Lee, C. M., 205
 Lee, G. K., 33
 Lee, K. H., 129
 Leete, E., 1, 2, 7, 8, 10, 11, 13,
 14, 16, 33, 57, 193
 Legault, D., 115
 Lehmann, H., 33
 Lehnert, W., 201
 Leimgruber, W., 114
 Leistner, E., 1, 2, 17
 Leitz, F. H. B., 8
 Lempka, A., 244
 Le Men, J., 204, 220, 221, 222,
 224, 239, 241, 242
 Le Men-Oliver, L., 204, 220,
 221, 222, 224, 241, 242
 Lenz, G. R., 144, 283
 Leont'ev, V. B., 94, 116
 Leow, H. M., 167
 Le Quesne, P. W., 226
 Letourneux, Y., 280
 Leute, R., 137
 Levenberg, B., 8
 Levesque, J., 192, 207, 208
 Levkovich, M. G., 116
 Lévy, J., 221, 224, 239, 242
 Lévy, M. C., 242
 Lewin, G., 222
 Lewis, R. G., 36
 Lhuguenot, J. C., 114
 Liang, Y. T. S., 292
 Lichman, K. V., 241
 Lieber, E. R., 53
 Liebisch, H. W., 8, 10
 Liede, V., 32
 Lin, L. J., 49
 Lin, Y. Y., 68
 Linde, W., 3
 Lindgren, J.-E., 32, 137
 Lindvall, O., 114
 Link, G., 128
 Lipsky, S. R., 50
 Lira, A., 181
 Littlewood, D. M., 190
 Loc, C. V., 121, 171
 Loder, J. W., 21
 Loehdefink, J., 192
 Loev, B., 97
 Lokensgard, D., 198
 Long, D. J., 3
 Long, J. P., 177
 Long, T. C., 228
 Longevialle, P., 65
 Lotti, V. J., 178
 Louden, M. L., 8
 Lounasmaa, M., 67
 Lovelady, H. G., 115
 Lovenberg, V., 71
 Lovkova, M. Y., 2
 Lowe, D. A., 49
 Lowry, B. R., 111
 Loyola, L. A., 254
 Lu, M. C. H., 283
 Lu, S. T., 160
 Luckner, M., 38
 Ludwicki, H., 71
 Lüning, B., 15, 72, 119
 Lukacs, G., 242, 249, 280, 282
 Luke, G. M., 123
 Lundström, J., 15
 Lunts, L. H. C., 117
 Lusinchii, X., 274, 275, 278
 Luther, G. W., 228
 Lutfullin, K. L., 66, 67, 148
 Lutomski, J., 67
 Mabe, J. A., 251
 Mabry, T. J., 41
 McCaldin, D. J., 19
 McCloskey, J. A., 65
 McDonald, E., 29
 MacDonald, J. C., 38
 McGrath, R. M., 30
 Machkova, Z., 284
 McHugh, J. L., 21
 Mackay, M. F., 93
 McKennis, H., 14
 McKenzie, E., 192
 McKeon, J. E., 51
 McLaughlin, J. L., 113, 119
 MacLean, D. B., 23, 24, 94,
 141, 254, 255
 McLean, E. K., 84
 McLean, S., 218, 220
 Mcleod, L. J., 168
 McMurtrey, K. D., 128
 McPhail, A., 54
 Maekh, S. Kh., 173, 186
 Mahajan, R. K., 290
 Mahran, G. H., 163
 Maier, W., 31
 Majer, J., 31
 Majumdar, P. L., 220, 232, 246
 Mak, M., 139
 Makleit, S., 139
 Maksyutina, N. P., 71
 Malanina, G. G., 285
 Maldonado, L. A., 184
 Mali, R. S., 106
 Malikov, V. M., 66, 67, 205,
 211, 220, 221, 226, 235
 Malinina, V. M., 131
 Mallett, G. E., 251
 Malyshev, V. V., 115
 Mami, I. S., 132
 Mandava, N., 66, 67, 191
 Mandeles, S., 2
 Mander, L. N., 267
 Mangeney, P., 224
 Mangione, G., 8
 Mangold, S., 201
 Manske, R. H. F., 24, 149, 158,
 161
 Mansour, M., 204, 221
 Mantle, P. G., 32
 Marchelli, R., 196
 Marcum, L. C., 139
 Margvelashvili, N. N., 160
 Marini-Bettòlo, G. B., 192, 221
 Marinov, M., 148
 Marion, L., 33, 258, 261
 Marquez, C., 181
 Marshall, I. G., 127, 148
 Marshall, W. D., 255
 Martin, J. A., 120
 Martin, R. O., 7
 Martin, T. I., 94
 Martin, W. F., 66
 Martinelli, E., 47, 49
 Martinelli, E. M., 233, 234, 247
 Martinod, D. P., 289
 Masada, Y., 174
 Masaki, N., 59
 Masamune, T., 293
 Mashkovskii, M. D., 69
 Maslin, D. M., 117
 Maslova, G. A., 154
 Massa, V., 154
 Massiot, G., 209, 227, 279
 Masuda, T., 138
 Mathe, I., 207, 220, 289
 Mathe, I., jun., 289, 290
 Mathieson, A. McL., 93
 Mathieson, D. W., 272
 Mathieu, R., 128
 Matiskella, J. D., 139
 Matsumoto, K., 130
 Matsumoto, K. E., 235
 Matsumoto, T., 264, 293
 Matsuo, K., 198
 Matsushita, K., 263
 Matsutani, M., 111
 Maume, B. F., 114
 May, E. L., 138
 Mazhar-UL-Haque, 255
 Mazza, M., 15, 39
 Medici, I., 171
 Mehta, R., 108, 111, 113
 Meinwald, J., 54
 Meisel, H., 221
 Mellon, F. A., 114
 Melnick, I., 8
 Meloni, M. L., 42
 Melvin, L. S., 62, 97
 Méndez, A. M., 91
 Menshikov, G. P., 77
 Merchant, J. R., 163
 Merianos, J. J., 183
 Merritt, W. V. P., 127
 Messenger, L., 41
 Meszaros, Z., 128
 Miana, G. A., 102, 179
 Michael, J. D., 36
 Midha, K. K., 115

- Mfet, C., 230
 Miller, D. D., 127
 Müller, H. E., 41
 Miller, L. L., 132
 Miller, R. W., 54
 Miller, W. L., 138
 Milliet, A., 282
 Milliet, P., 275, 278
 Milner, J. A., 29, 140
 Minami, K., 136
 Minghetti, A., 31
 Minker, E., 103
 Mirando, P., 199
 Mirzamatov, R. T., 66, 67
 Misawa, K., 171
 Mitchell, M. J., 165
 Mitchell, W., 66
 Mitscher, L. A., 120, 174, 187
 Mitsuhashi, H., 52, 293
 Miura, I., 45
 Miyaki, K., 197
 Mizusaki, S., 2
 Modan, B., 140
 Moevik, B., 114
 Moffatt, A. C., 138
 Mokry, J., 209, 221
 Mollov, N. M., 173, 261
 Moltrasio, G. Y., 182
 Monache, F. D., 192
 Monakhova, T. E., 90
 Moniot, J. L., 22, 149, 170, 172, 173, 179
 Monković, I., 134, 139
 Monseur, X., 191
 Montgomery, M. R., 137
 Montzka, T. A., 139
 Moodie, I. M., 115
 Moore, J. B., 41
 Moorhouse, A., 21
 Mootoo, B. S., 253
 Morales, G., 254
 Morecombe, D. J., 49
 Moreland, C. G., 243
 Morgan, J. M., 173
 Morgan, P., 138
 Mori, H., 283
 Mori, M., 115, 131
 Morimoto, A., 138
 Morin, R. D., 192
 Morita, Y., 220, 243
 Moritz, W., 53
 Moro, G. A., 191
 Morozovskaya, L. M., 285
 Morrow, C. J., 244
 Mose, W. P., 72, 76
 Mosettig, E., 285
 Mosquera, R., 92
 Mothes, K., 6
 Motoki, C., 52, 293
 Mourño, A., 182
 Moutschen, J., 148
 Moutschen-Dahmen, M., 148
 Mucharska, A., 71
 Mudzhiri, K. S., 221
 Mueller, R. H., 101
 Müller, W., 193
 Muira, H., 71
 Mukhopadhyay, P., 182
 Mulchandani, N. B., 89
 Mule, S. J., 114, 137
 Munro, M. H. G., 139
 Murakami, Y., 190
 Murphy, S. T., 103
 Murray, D. G., 218
 Murrill, J. B., 11
 Musso, H., 113
 Mustich, G., 233, 234, 247
 Nabiev, A., 289
 Nagakura, N., 123, 141
 Nagarajan, K., 117
 Nagel, D. W., 199
 Naghaway, J., 168
 Naito, T., 151, 152, 206
 Nakagawa, K., 136
 Nakagawa, M., 192
 Nakajama, K., 152
 Nakamura, G. R., 137
 Nakamura, S., 172
 Nakanishi, K., 45, 117
 Nakano, T., 91
 Nakao, T., 115
 Nakashima, R., 38
 Nakashima, T. T., 255
 Nakashita, Y., 170
 Nalliah, B., 24, 149, 158
 Narasimhan, N. S., 106
 Narimatsu, Y., 54
 Narrod, S. A., 8
 Narzullaev, A. S., 259
 Nash, C. H., 49
 Nasirov, S. M., 260
 Nasra, M. A., 140
 Nasser, P., 132
 Nasyrov, S. M., 235
 Natarajan, S., 88, 127, 128, 229
 Natsume, M., 265
 Ndalut, P. K., 103
 Neel, W. W., 99
 Neidle, S., 73
 Neitz, A. W., 30
 Nelson, R. B., 193
 Nelson, U., 31
 Nemeckova, A., 111, 159
 Nemoto, H., 159, 246
 Nettleship, L., 192
 Neumeyer, J. L., 175, 178
 Neuss, N., 49, 235, 246, 247, 251
 Newberne, P. M., 84
 Newton, M. G., 262
 Nezhevenko, V. E., 257, 258
 Nguyen, P. L., 137
 Nguyen, T. T., 255
 Nichols, P. R., 99
 Nicklin, P. D., 272
 Nicolaou, K. C., 62, 97
 Nikiforov, A., 223
 Nikokavouras, J., 125
 Ninomiya, I., 151, 152, 175, 206
 Nishi, K., 131
 Nishimura, H., 235
 Nishimura, J. S., 42
 Nishio, K., 253
 Nishioka, I., 123, 143, 153
 Niwa, H., 257, 269
 Nizamkhodzhaeva, A., 92
 Nobili, F., 42
 Nodiff, E. A., 117
 Noguchi, I., 141, 167
 Noguchi, T. T., 137
 Noirfalise, A., 137
 Nonaka, G., 123, 143, 153
 Novak, I., 103
 Novak, V., 128, 151, 175
 Nover, L., 38
 Novruzov, E. N., 288
 Nowacki, E. K., 6, 12, 90
 Nugent, J. F., 23
 Numata, A., 66
 Nunez, C. S., 45
 Nurimoto, S., 138
 Nurimov, E. I., 2
 Nwaji, M. N., 190
 Nyembo, L., 254
 Nyman, U., 131
 Nyu, K., 144
 Oberhaensli, W. E., 156
 Obi, M., 192
 O'Brien, C., 137
 O'Brien, P. F., 183
 Occolowitz, J., 49
 Occolowitz, J. L., 190
 Odham, G., 65
 O'Donovan, D. G., 3, 5, 16, 33
 Ogasawa, K., 171
 Ogawa, M., 175
 Ogawa, N., 96
 Ogawa, T., 126, 147
 Ogihara, Y., 124
 Ohashi, M., 65
 Ohashi, T., 31
 Ohba, T., 122
 Ohhira, H., 223
 Ohjama, K., 120
 Ohmori, S., 121
 Ohmori, T., 217
 Ohmoto, S., 31
 Ohno, M., 131
 Ohno, T., 131
 Ohnuma, T., 238
 Ohnoishi, T., 189
 Ohtani, H., 202
 Ohtani, M., 252
 Oishi, T., 238
 Okada, J., 153
 Okada, K., 113
 Okamoto, T., 265

- Okamura, K., 192
 Okarter, T., 166
 Okawara, T., 123
 Oki, M., 252
 Okladnikov, V. I., 115
 Oleksevich, V. M., 148
 Oliver, J. E., 86
 O'Loughlin, G. J., 244
 Olson, J. O., 7
 Omura, S., 54
 Onda, M., 54, 153
 Onyiriuka, S. O., 190
 Oppolzer, W., 59, 240
 Orahovats, A., 173
 Orazmuradov, G. M., 282
 Orfanides, N., 56
 Orito, K., 161
 Oseigymah, P., 127
 Otani, S., 42
 Otsuka, H., 124
 Otta, H., 185
 Otta, K., 230
 Ouchi, R., 283
 Overton, K. H., 264
- Paalzow, L., 137
 Pachaly, P., 165
 Pachler, I. J., 134
 Pachler, K. G. R., 199
 Page, S. W., 256
 Pai, A., 111
 Pai, B. R., 88, 89, 121, 127, 128, 176
 Pailer, M., 183, 184, 280
 Pais, M., 191
 Pakaln, D. A., 174, 282
 Pakrashi, S. C., 111
 Palla, G., 30
 Palmisano, G., 195
 Panas, J. M., 220, 222, 241
 Pancrazi, A., 273
 Pandey, V. B., 141
 Parello, J., 65
 Paris, M. R., 108
 Paris, R. R., 58, 90, 108, 154, 165, 192
 Parker, C. W., 138
 Parry, R. J., 28, 40, 41
 Parsons, P. G., 33
 Parthasarathy, P. C., 117
 Pascard-Billy, C., 234, 247
 Pashchnichenko, V. A., 53
 Paslarasu, N., 90
 Passon, P. G., 114
 Pasteels, J. M., 99
 Patel, B., 33
 Patel, V. P., 33
 Patnaik, P. C., 172
 Paton, J. M., 98
 Patra, A., 173
 Paul, D., 284
 Pauli, K. D., 148
 Pauson, P. L., 98
- Pavelka, S., 148
 Pavloff, A. M., 117
 Pecket, R. C., 41
 Pelletier, O., 218
 Pelletier, S. W., 256, 258, 262
 Pelton, M. R., 139
 Pendse, G. S., 289
 Perelson, M. E., 90, 139
 Perlman, D., 12, 42
 Perlman, K. L., 42
 Perron, Y. G., 134
 Persaud, T. V. N., 85
 Petcher, T. J., 192
 Petcu, P., 148
 Petter, A., 220
 Petty, C., 137
 Petty, J. D., 121
 Petz, M., 103
 Peuler, J. D., 114
 Peverada, P., 50
 Pfäffli, P., 240
 Pfeifer, S., 128
 Philip, A., 243
 Phillips, R., 71
 Phillips, S. R., 115
 Phillipson, J. D., 66, 88, 202, 204, 205, 206, 212, 225
 Piattelli, M., 26, 41
 Picot, A., 274
 Picot, F., 192
 Pilea, M., 148
 Pinder, R. M., 117
 Piozzi, F., 105, 107
 Piu, P., 114
 Plat, M., 210
 Platt, R., 34, 214
 Plattier, M., 63
 Plichat, L., 272
 Phieninger, H., 32, 201
 Pochini, A., 196
 Poisson, J., 103, 154, 222, 230, 239
 Popli, S. P., 222
 Papov, P., 131
 Popp, F. D., 175
 Porter, J. K., 200
 Posner, G. H., 111
 Potgieter, D. J. J., 30
 Potherat, J. J., 128
 Potier, P., 172, 192, 209, 224, 226, 227, 229, 233, 234, 235, 241, 247, 249, 279
 Potron, C., 222, 241
 Potter, C. J., 25
 Poupat, C., 26
 Pousset, J. L., 103, 108, 117, 154, 192, 205, 207, 208
 Powell, J. B., 137
 Pradhan, S. N., 117
 Prager, R. H., 267
 Pras, M., 140
 Preaux, N., 210
 Preininger, V., 154, 159, 174
 Priestap, H. A., 183, 184, 186
- Premila, M. S., 128, 176
 Preston, N. W., 172
 Preuss, R., 113, 193
 Priess, J., 8
 Proskurnina, N. F., 90
 Przybyska, M., 264
 Puri, S. C., 80
 Purushothaman, K., 261
- Qadri, S. M. H., 52
 Quick, A., 255
 Quigley, F. R., 201
 Quimby, W. C., 5
 Quirin, F., 220
 Quock, R. M., 178
 Qureshi, A. A., 229
- Racz, I., 128
 Radhakrishnan, J., 88
 Radu, A., 148
 Raffauf, R. F., 76
 Rahman, A.-U., 54
 Rainoldi, G., 195
 Raj, K., 222
 Rajagoplan, T. G., 117
 Ramachandran, C., 137
 Ramachandran, V., 132
 Ramage, R., 29, 139
 Ramanathan, V. S., 137
 Rampal, A. L., 290
 Rampal, J. B., 125
 Ramuz, H., 19
 Ranieri, R. L., 45
 Rao, G. S., 16
 Rao, K. K., 33
 Rao, K. V., 76, 174, 186
 Rao, S. G., 117
 Rapoport, H., 2, 244
 Rashkes, Ya. V., 82, 83, 84, 103, 139, 261
 Rasoanaivo, P., 234, 247
 Rastogi, R. P., 201
 Ratcliffe, A. M., 240
 Ray, A., 165
 Ray, A. B., 141, 204
 Razafindrambao, R. S., 222
 Redfield, B. G., 42
 Rehacek, Z., 201
 Reisch, J., 103
 Reiter, M., 290
 Rejent, T. A., 138
 Renner, U., 220, 243
 Renwick, J. D., 72, 76
 Renz, J., 3
 Revach, M., 140
 Rhodes, R. E., 247
 Ribas, I., 92, 183
 Rich, P., 117
 Richard, B., 220, 222, 241
 Riche, C., 234, 247
 Richter, H., 38
 Rickards, R. W., 42
 Riesner, H., 251
 Ripperger, H., 53

- Rippstein, S., 137
 Riscalcic, E., 280
 Ritchie, A. C., 117
 Ritchie, E., 103
 Ritter, F. J., 86
 Robbers, J. E., 32
 Robbins, J. D., 200
 Roberts, J.-L., 45
 Roberts, M. F., 7
 Robertson, L. W., 173
 Robins, D. J., 12, 47, 83
 Robinson, D., 16
 Robinson, R., 23
 Roddick, J. G., 53
 Rodrigo, R., 24, 149, 158, 161
 Rodwell, V. W., 13
 Roerig, S., 136
 Roeske, W. R., 53
 Roffler-Tarlov, S., 178
 Rogers, A. E., 84
 Rogers, D., 255
 Rogers, M. E., 138
 Rogozhin, S. V., 117
 Rolland, Y., 230
 Ronachenko, G. N., 286, 287
 Romanchuk, M. A., 81
 Rono, J. 184
 Ronchetti, F., 53
 Rosenberg, H., 17
 Rosenberg, H. E., 190
 Rosenblom, J., 15, 119
 Rosenmund, P., 195
 Ross, R., 137
 Rotgans, I. E. M., 86
 Rothenberg, A. S., 179
 Rother, A., 98
 Rothmaler, W., 254
 Roullier, P., 63
 Roy, S., 190
 Royer, M. E., 114
 Rózsa, Zs., 103
 Rubinstein, W., 77
 Rubtsov, A. F., 137
 Ruchirawat, S., 26
 Runeckles, V. C., 187
 Rusinova, V. N., 69
 Russell, R. A., 38
 Russo, G., 53, 195
 Rustanov, Kh. R., 117
 Ruthren, C. R. J., 123
 Ruveda, E. A., 147, 183, 184, 186
 Ryles, A. P., 37
- Saa, J. M., 165, 183
 Saari, W. S., 178
 Sadykov, A. A., 116
 Sadykov, A. S., 7, 90, 92, 94, 116, 170
 Sadykov, B., 91
 Saini, M. S., 32
 Sainsbury, M., 229
- Saito, H., 115
 Saito, S., 138
 Sajdl, P., 201
 Saji, I., 59
 Sakabe, 270
 Sakai, S., 192, 202, 217, 223, 249
 Sakamoto, M., 113
 Salama, R. B., 115
 Saleh, A. A., 289
 Salgar, S. S., 163, 171
 Salomatin, E. M., 137
 Sanek, Z., 190
 Samikov, K., 289, 295
 Sammes, P. G., 124
 Sanchez, E., 124
 Sandler, M., 123
 Sangaré, M., 282
 Sankawa, U., 40, 197
 Šanlevý, F., 261
 Sansur, M., 137
 Šantavy, F., 76, 81, 111, 152, 159
 Santer, U. V., 51
 Santiago, J. V., 114
 Santos, A. C., 169
 Sapeika, N., 115
 Sarges, R., 121
 Sartori, G., 46
 Sasagawa, S., 183
 Sasago, K., 197
 Sasaki, K., 251, 267, 268
 Sass, S., 71
 Sassa, H., 96, 97
 Satish, S., 19
 Sato, Y., 285
 Satoh, F., 111, 144, 157, 162, 180
 Satzke, L., 93
 Saucier, M., 134
 Saunderson Huber, C., 66
 Savage, D. S., 283
 Savaskan, S., 243
 Savory, J., 114
 Sawa, Y., 138
 Sawhney, R. S., 72, 78, 80, 85
 Sawyer, B. C., 8
 Schabort, J. C., 30
 Schaller, H. J., 10
 Scharver, J. D., 141
 Scheiber, P., 68
 Scheinmann, F., 175
 Schenetti, L., 116
 Scheuer, P. J., 103
 Schiff, P. L., jun., 131, 166, 167, 170
 Schildknecht, H., 56
 Schill, G., 71
 Schimazi, R., 229
 Schleppnik, A., 184
 Schlitter, E., 189, 220
 Schmalz, D., 201
 Schmid, H., 220, 243
 Schnoes, H., 49
- Schoenfeld, R. I., 178
 Schoental, R., 84, 85
 Schor, S., 140
 Schreiber, K., 53, 285, 288, 290, 293
 Schütte, H. R., 6, 8, 16, 17, 33
 Schwarzberg, N., 182
 Schwab, J. M., 28
 Schwarting, A. E., 97, 98
 Schwartz, M. A., 132
 Schwarze, W., 3
 Schwedt, G., 115
 Sciuto, S., 41
 Scopes, P. M., 72, 76, 91
 Scott, A. L., 36, 189, 227, 229
 Scott, P. M., 197
 Scriabine, A., 178
 Sedmera, P., 76, 81
 Seelig, G., 16
 Šefčovič, P., 221
 Segelman, A. B., 203
 Seidner, A., 137
 Seigfried, J., 114
 Seitanidi, K. L., 103
 Seki, K., 238
 Sen, R., 103
 Septe, B., 282
 Seth, D. K., 289
 Seto, H., 52, 293
 Shaath, N. A., 123, 168
 Shabana, M. M., 289
 Shah, S., 114
 Shakhidoyatov, Kh., 108
 Shakirov, R., 282, 289, 295
 Shakirov, T. T., 148
 Shamma, M., 22, 23, 120, 149, 156, 170, 171, 172, 173, 175, 179, 181, 186
 Shank, R. C., 198
 Shannon, P. V. R., 121, 125
 Sharipov, M. R., 220, 226
 Sharma, A., 290
 Sharma, S. C., 117
 Shatunova, L. K., 115
 Shaw, C. K., 50
 Shaw, R., 281
 Sheichenko, V. I., 182
 Sheldrake, P. W., 29, 140
 Shelkovoï, V. D., 68
 Shellard, E. J., 36, 205, 206, 212
 Sherma, J., 114
 Shiau, G. T., 140
 Shiba, T., 111
 Shibata, S., 124
 Shibuya, S., 126, 130, 147, 187
 Shigeura, H. T., 47
 Shimamine, M., 131
 Shimezawa, C., 97
 Shimizu, B., 63
 Shingu, T., 172
 Shinkarpenko, A. L., 292
 Shinma, N., 217
 Shinohara, Y., 121

- Shinzaburo, O., 70
 Shioiri, T., 192
 Shirasaki, S., 131
 Shirshova, T. I., 193
 Shishido, K., 132
 Shizuri, Y., 251
 Shoeb, A., 222
 Shoolery, J. N., 234
 Shostenko, Yu. V., 68
 Shraker, S. R., 165
 Shudo, I., 115
 Shukla, Y. N., 117
 Shumaker, R. C., 85
 Shuster, L., 8
 Sigaut, C., 220
 Sih, C. J., 49
 Silinis, H., 110
 Silva, M., 124
 Simanek, V., 111, 154, 159
 Simmons, D. L., 258
 Simon, I. S., 68
 Simon, J. C., 128
 Šimónek, V., 261
 Simonisch, E., 183
 Sine, H. E., 138
 Singer, P. P., 254, 255
 Singh, A., 262
 Singh, G., 151
 Singh, H., 85, 225, 262, 284
 Singh, I., 254
 Singh, M., 290
 Singh, N., 262
 Singh, S., 288
 Sioumis, A. A., 21, 65, 100, 181
 Sisti, M., 55
 Sivak, A., 42
 Skeils, M., 117
 Skolik, J., 91, 92
 Slater, G. P., 38
 Slater, T. F., 8
 Slatkin, D. J., 131, 166, 167, 170
 Slavik, J., 124, 128, 143, 151, 152, 170, 175
 Slavikova, L., 124, 170
 Slaytor, M., 192
 Smith, D. A., 137
 Smith, D. W., 137
 Smith, E. H., 11
 Smith, G. F., 240
 Smith, G. N., 33, 240
 Smith, H., 41
 Smith, L. W., 72, 75
 Smith, R. V., 178
 Smith, T. A., 116
 Smith, T. K., 21
 Smolanoff, J., 54
 Smolenski, S. J., 110
 Sneath, T. C., 115
 Snieckus, V., 229
 Snyder, S. R., 115
 Sobiczewska, M., 71, 163
 Sohar, E., 140
 Soine, T. O., 123, 129, 168, 179
 Sojo, M., 181
 Solomon, P. H., 45
 Solt, M. L., 2
 Solter, L. E., 121
 Sommerville, P., 74
 Sonnet, P. E., 86
 Sorm, F., 190
 Sotheeswaran, S., 167
 Soti, F., 65
 Sotiriou, A., 195
 Southgate, R., 22
 Spalla, C., 31
 Spector, S., 137
 Spencer, H., 34, 214
 Spenser, I. D., 1, 2, 3, 6, 17, 23, 68, 185, 255
 Spilles, C., 175
 Spiltes, C., 120
 Spiteller, G., 209, 226
 Spiteller-Friedmann, M., 226
 Sprague, P. W., 36
 Sprancmanis, V., 123
 Sprecher, M., 47
 Springer, J. P., 198
 Sprinson, D. B., 47
 Spyropoulos, C. G., 39, 40, 103
 Srimal, R. C., 171
 Srinivasan, M., 125
 Srinivasan, P. R., 47
 Srivastava, R. S., 111, 191
 Stadler, P., 32
 Stanescu, U., 260
 Stanislas, E., 143
 Starodubtseva, R. V., 81
 Starzec, N., 94
 Staunton, J., 1, 6, 7, 16, 20, 21, 22, 26, 30, 31, 33, 39, 144, 147
 Staeck, E. A., 69
 Steglich, W., 113
 Stein, F., 86
 Stenlake, J. B., 127, 148, 184
 Sterk, L., 121
 Stermitz, F. R., 128, 132, 152
 Stermitz, J. R., 128
 Sternhell, S., 205
 Stevens, T. S., 98
 Stewart, G. W., 120
 Steyn, P. S., 30, 199
 Störr, K.-H., 69, 70
 Stohs, S. J., 17
 Stojaczyk, M., 137
 Stoll, F. A., 20
 Stone, K. J., 53
 Stork, G., 238
 Strawson, C. J., 196
 Strima, L., 114
 Struchkov, Yu. T., 93, 235, 260
 Stuart, K., 189
 Stuart, K. L., 21, 192
 Stutz, M. H., 71
 Su, T. L., 160
 Soares, J., 100
 Suau, R., 182
 Subramanian, P. S., 88
 Suchan, V., 155
 Sugai, S., 69
 Sugii, M., 71
 Suginome, H., 264
 Sugiura, K., 64
 Sugiura, M., 115
 Sugiura, S., 58
 Suguhara, T., 132
 Sugura, H., 121
 Suhadolnik, R. J., 15
 Sultanov, M. B., 169
 Suri, K. A., 85
 Suri, O. P., 78
 Susplugas, J., 154
 Susplugas, P., 154
 Sussman, J. L., 83
 Suszko, J., 244
 Suvorov, N. N., 69, 285
 Suzuki, M., 56
 Svendsen, A. B., 137, 225
 Svensson, L. A., 114
 Svetkova, E. T., 148
 Svetlichnaya, V. I., 140
 Svoboda, G. H., 120, 174, 233, 235, 247
 Sykes, R. J., 50
 Syono, K., 131, 175
 Szabo, L., 163, 229
 Szakolcai, A., 218, 220
 Szantay, C., 163
 Szauffer, M., 148
 Szczyrbak, C. A., 32
 Szendrei, K., 103
 Szentirmay, E., 163
 Szentmiklosi, P., 128
 Szilasi, M., 230, 246
 Tabar, W. A., 31, 33
 Tabuchi, T., 31
 Tackie, A. N., 131, 166, 167, 170
 Tada, M., 261
 Taddei, F., 116
 Tadzhibaev, M. M., 148
 Tafaneli, A., 290
 Taga, M., 120
 Tagahara, K., 22
 Taguchi, M., 223, 249
 Taha, A. M., 115
 Takahagi, Y., 147
 Takahashi, H., 31
 Takahashi, K., 121, 131, 146, 171, 192, 223, 249
 Takahashi, M., 137
 Takahashi, T., 162, 213
 Takahashi, Y., 283
 Takanaev, A. A., 6, 7
 Takano, S., 132
 Takao, N., 153
 Takasugi, M., 293
 Takeda, H., 162, 246
 Takeda, M., 138

- Takemoto, T., 146
 Takemura, M., 145, 146
 Takeshita, M., 144, 146
 Talapatra, B., 173, 182
 Talapatra, S. K., 173
 Talman, E., 86
 Tamaki, E., 2, 14
 Tamas, J., 128, 207, 220, 246
 Tamm, C., 44, 45
 Tamura, Z., 115
 Tanabe, K., 117
 Tanabe, M., 28
 Tanaka, H., 54
 Tanaka, J., 217
 Tanaka, K., 59, 133
 Tanaka, O., 113
 Tanaka, S., 69, 70, 174
 Tanas, J., 139
 Tandani, J. S., 117
 Tang, C. S. F., 244
 Tani, C., 22, 123, 141
 Tanrikut, Y., 186
 Tantivatana, P., 205
 Taylor, D. A. H., 190
 Taylor, D. R., 253
 Taylor, J. D., 138
 Taylor, W. C., 103
 Tazima, Y., 84
 Tcheng, M., 31
 Tcheng-Lin, M., 32
 Teisseire, P., 63
 Teitel, S., 122
 Telenkova, O. V., 69
 Telezhenetskaya, M. V., 79, 108
 Tel'nov, V. A., 260, 261
 Temperilli, A., 201
 Tengi, J. P., 114
 Terasawa, H., 180
 Terenteva, I. V., 110, 193
 Terui, T., 145
 Tevlina, A. S., 81
 Tewari, S., 20
 Tezcan, I., 88
 Thal, C., 229
 Thepenier, P., 220
 Thiel, J., 244
 Thomas, D., 128
 Thomas, R. N., 91
 Thomas W. R., 121
 Thompson, A. C., 99
 Thornber, C. W., 26
 Thut, C. C., 68
 Tiley, E. P., 144
 Tillack, J. V., 132
 Timmins, P., 203
 Ting, J. -S., 111
 Tinwa, M., 152
 Titeux, F., 204
 Tiwari, H. P., 185
 Tobinaga, S., 98, 111
 Toda, M., 257, 268, 269
 Todd, M., 21
 Toi, K., 117
 Tokita, S., 130
 Tokuama, T., 58
 Tolkachev, O. N., 90, 154, 160, 174, 182, 282
 Tomczyk, H., 78
 Tomita, K., 153, 253
 Tomita, M., 183
 Tomko, J., 209, 290, 293, 294
 Tonozuka, M., 192
 Torchiana, M. L., 292
 Toromanoff, E., 171
 Torres, R., 124
 Toshioka, T., 175
 Tosnarova, V., 174
 Tóth, J., 68
 Toube, T. B., 73
 Touchstone, J. C., 114
 Tower, R., 218
 Towers, N. R., 30
 Treagust, P. G., 65
 Treasurywala, A. M., 249
 Trevett, M. E., 265
 Tripp, C. H., jun., 137
 Trojaneek, J., 155, 189, 204, 224, 243
 Truhaut, R., 137
 Trybulski, E. J., 59
 Tsai, A. I.-M., 95
 Tsai, T. Y., 264
 Tsanev, K. G., 148
 Tsatsas, G., 125
 Tschertner, H., 199
 Tschesche, R., 53, 120, 175
 Tsohis, A., 125
 Tsuchida, E., 170
 Tsutsumi, J., 70
 Tsvetkov, I., 148
 Tuchweber, B., 85
 Tufariello, J. J., 59
 Tull, R., 292
 Turdikulov, K., 170
 Turner, A. B., 115
 Turner, A. J., 128
 Turner, D. W., 25
 Turovska, M., 67
 Turowska, W., 282
 Tursch, B., 99
 Tust, R. H., 235
 Tutt, K. J., 117
 Twycross, R. G., 137
 Tyfczynska, J., 168
 Ubaidullaev, K. A., 295
 Uchida, S., 170
 Ueda, E., 120, 152
 Ueda, M., 151
 Uemura, D., 217
 Uenoyana, K., 58
 Ugerstedt, U., 178
 Ujiie, A., 144, 147
 Ujjasz, K., 128
 Ulubelen, A., 75, 90
 Umarov, Kh. S., 186
 Umberger, C. J., 138
 Umezawa, B., 120, 121, 175
 Underhill, E. W., 8
 Undheim, K., 122
 Uprety, H., 19
 Ursu-Kenyeres, I., 140
 Ursu-Kenyeres, V., 140
 Urzua, A., 103, 174
 Usategui, M., 137
 Ustyynyuk, Yu. A., 94
 Vachnadze, V. Y., 221
 Vaishnav, Y. N., 16
 Vaitekunas, A. A., 14
 Valenta, J., 212
 Valenta, Z., 265
 Valentini, J., 228
 Vanderveen, R. L., 113
 Vanevenhoven, P. W., 183
 Van Hoeven, H., 97
 Van Tamelen, E. E., 53, 217
 Van Wyk, A. J., 131
 Vaquette, J., 103, 108, 154
 Varley, M. J., 30
 Varmuza, K., 223
 Vassová, A., 293
 Vederas, J. C., 45
 Venkatachalam, S. R., 89
 Venkateswarlu, A., 174
 Vent, W., 154
 Venturella, P., 105 107
 Vernengo, M. J., 182
 Verner, D., 115
 Verpoorte, R., 111, 137, 225
 Verweil, P. E. J., 86
 Vesely, J., 154
 Vesely, Z., 155
 Vetter, W., 65
 Viala, A., 137
 Vida, J. A., 117
 Vieboeck, F., 132
 Villa, L., 116
 Vincze, I. W., 68
 Vining, L. C., 31, 33, 45
 Vinnitskaya, E. B., 115
 Viswanathan, N., 88, 89
 Vlegaar, R., 30
 Völkl, A., 201
 Voigt, D., 201
 Vokoun, J., 201
 Volodarskaya, N. S., 117
 von Ardenne, R., 113
 Votický, Z., 202, 209, 290, 294
 Vul'fson, N. S., 91
 Vulkov, I., 148
 Wachtmeister, C. A., 20
 Waigh, R. D., 148
 Waight, E. S., 32
 Wakahara, A., 153
 Wakisaka, K., 167
 Walker, J. E., 42
 Wallace, J. E., 137
 Waller, G. R., 6, 7, 8, 90
 Walterova, D., 111

- Walton, H. F., 111
 Wang, M.-T., 115
 Wang, R. I. H., 136
 Wang, T. S. T., 117
 Ward, M. A., 42
 Ward, P. C. J., 137
 Wardell, J. R., jun., 117
 Warnant, J., 171
 Warren, K. E. H., 33
 Wasserman, H. H., 50, 51
 Watanabe, M., 52, 293
 Waterman, P. G., 103, 111, 154
 Way, E. L., 137
 Webb, B., 229
 Weber, A. E., 111
 Weber, H. P., 59, 192
 Weber, N., 166
 Wei, C. C., 227, 229
 Weichmann, M., 68
 Weinbergová, O., 72
 Weinreb, S. M., 198
 Weisbach, J. A., 76, 174, 212
 Weiss, S. G., 235
 Weiss, U., 132
 Weissbach, H., 42
 Wells, J. M., 199
 Wells, R. B., 73
 Wels, C. M., 49
 Wenger, R., 240
 Wenkert, E., 36, 67, 244
 Werner, G., 68, 69, 70
 Werner, S., 38
 Wessels, P. L., 199
 West, L. G., 113, 119
 Westcott, N. D., 35
 Westphal, J., 201
 White, A. W. C., 126
 White, E. H., 5
 White, R. J., 46, 47, 49
 Whitehouse, D., 11
 Whiting, D. A., 109
 Whitlock, E., 114
 Wichtl, M., 223
 Widdowson, D. A., 25, 116
 Widiger, G. N., 58
 Wiechers, A., 131
 Wiegels, M., 114
 Wiegrebe, W., 290
 Wieland, H., 3
 Wiesner, K., 258, 264, 265
 Wiewiórowski, M., 91, 92
 Wightman, R., 198
 Wilkens, D. C., 30
 Wilkins, D. C., 30
 Wilkinson, G. R., 128
 Wilkinson, J. R., 122
 Williams, D. K., 128
 Williams, R. P., 52
 Williams, W. D., 127, 148, 184
 Wills, P. D., 137
 Wilson, M. L., 18, 125, 170
 Wiltshire, H. R., 144
 Winter, K., 38
 Winterfeldt, E., 36, 189, 193, 251
 Winzenburg, K. N., 62
 Witkop, B., 58
 Wodak, S. J., 80, 83
 Wogan, G. N., 198
 Wolff, S. M., 140
 Wolinska-Mocydla, J., 93
 Wong, C. F., 94, 95
 Wong, F., 240
 Wong, H., 134
 Wooley, J. G., 10, 11, 65
 Woolley, V. A., 10, 66
 Woo-Ming, R., 189, 192
 Wormser, H. C., 183
 Workulich, P. H., 67
 Worlever, J., 95
 Wright, D. E., 30
 Wright, H., 249
 Wright, H. E., 198
 Wright, L. H., 262
 Wróbel, J. T., 94
 Wrzecziono, Y., 282
 Wu, A., 229
 Wu, M.-D., 139
 Yagudaev, M. R., 103, 177, 211, 226, 235
 Yajima, T., 12
 Yakhontova, L. D., 174, 182
 Yamada, J., 283
 Yamada, K., 56, 64, 217, 251
 Yamada, N., 130
 Yamada, S., 12, 192
 Yamaguchi, H., 66
 Yamaguchi, K., 192, 223, 249
 Yamaguchi, M., 263
 Yamamura, S., 257, 267, 268, 269, 270
 Yamanaka, E., 249
 Yamasaki, K., 113
 Yamasaki, Y., 40
 Yamashita, H., 71
 Yamato, M., 121
 Yamazaki, M., 197
 Yang, K. S., 7, 8
 Yang, T.-H., 123
 Yankovskii, B. A., 90
 Yankulov, I., 71
 Yao, S. Y., 179
 Yashunsky, V. G., 117
 Yasuda, S., 96
 Yeh, C. L., 36
 Yeh, S.-Y., 138
 Yokomatsu, T., 126, 130, 147
 Yoshida, M., 113
 Yoshifuji, S., 162, 163
 Yoshikawa, Y., 172, 174, 181
 Yoshikoshi, A., 139
 Yoshino, A., 265
 Yoshioka, M., 115
 Young, D. W., 49
 Youngken, H. W., jun., 8
 Yuan, S. S., 198
 Yuasa, K., 153
 Yui, M., 192
 Yunusov, M. S., 149, 257, 258, 259, 260, 261
 Yunusov, S. Yu., 66, 67, 72, 79, 82, 83, 84, 91, 103, 108, 139, 149, 172, 173, 177, 186, 189, 205, 211, 220, 221, 226, 235, 257, 258, 259, 260, 261, 282, 289, 295
 Yunusov, T. K., 116
 Yupraphat, T., 165
 Yusunov, A. K., 123
 Yusupov, M. K., 170
 Zaikin, V. G., 91
 Zaitseva, K. A., 69
 Zakharov, V. P., 90
 Zarembo, J. E., 212
 Zatorskaya, I. N., 148
 Zbaida, S., 54
 Zeches, M., 222
 Zee-Cheng, K.-Y., 148
 Zeisberg, R., 91
 Zenk, M. H., 3
 Zerner, D., 140
 Zharekeev, B. Kh., 108
 Zhorov, B. S., 117
 Ziegler, H. W., 137
 Ziyayev, R., 172
 Ziyavidinova, Z. S., 91
 Zmijewski, M. J., jun., 41, 42
 Zononi, T. A., 128
 Zowalewski, Z., 148
 Zsados, B., 230, 246
 Zulalian, J., 15
 Zutshi, U., 289
 Zymalkowski, F., 165

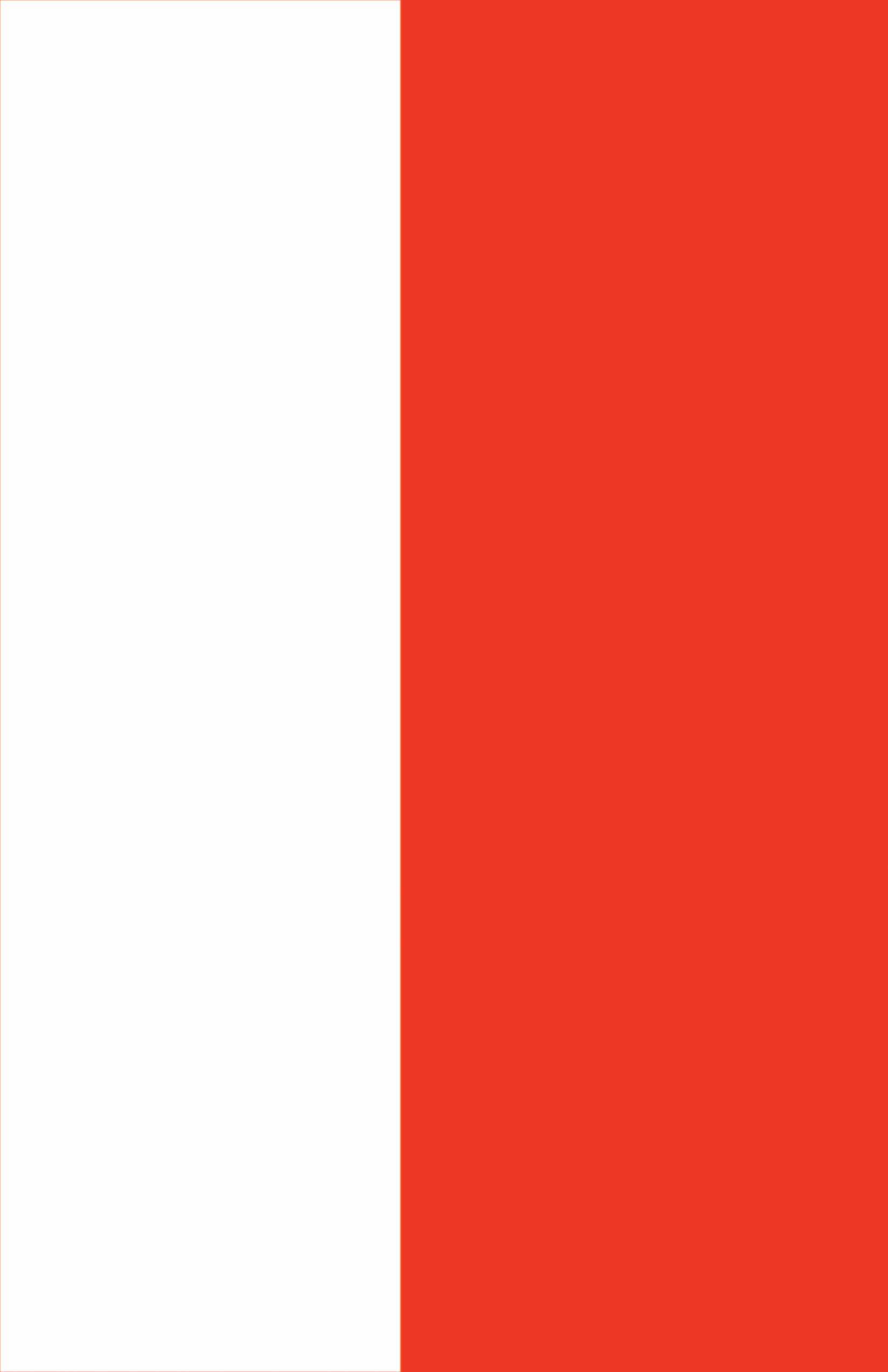



The Chemical Society

Specialist Periodical Reports

A series of reviews by leading specialists in their fields which gives systematic and comprehensive coverage of the progress in major areas of research. Titles of interest to those working in the borderlands of chemistry and biology include:

Foreign Compound Metabolism in Mammals Vol. 3

Senior Reporter: Dr. D. E. HATHWAY
I.C.I. Limited

"This work will be extremely useful to all clinical pharmacologists, toxicologists, and biochemists, as well as to interested chemists, as an up-to-date reference work. It also provides interesting reading, and goes into principles and the development of the problems."—*Angewandte Chemie*, reviewing Vol. 2. 744pp (still available: Vols. 1 and 2)

Biosynthesis Vol. 4

Senior Reporter: Dr. J. D. BU'LOCK
University of Manchester

"The extensive research published in this area over the past several years is clearly reviewed by experts in the area. It is a stimulating account of recent progress in this area."—*Ludwig Bauer* reviewing Vol. 1 in the *Journal of the American Chemical Society*. 284pp. (still available: Vols. 1, 2 and 3)

Environmental Chemistry Vol. 1

Senior Reporter: Prof. G. EGLINTON
University of Bristol

The first volume in a new series of biennial reports on environmental chemistry. This volume concentrates on organic aspects of the subject and future volumes will cover inorganic and other aspects. 210pp

Amino-acids, Peptides and Proteins Vol. 7

Senior Reporter: Dr. R. C. SHEPPARD
MRC Laboratory of Molecular Biology, Cambridge

"The reviewers have done a superlative job of assimilating the data from these many papers and accentuating the important aspects of them."—*John Morrow Stewart*, *Journal of Medicinal Chemistry*, reviewing Vol. 3. 448pp (still available: Vols. 1—6)

Terpenoids and Steroids Vol. 5

Senior Reporter: Prof. K. H. OVERTON
University of Glasgow

"Organic chemists working on any aspect of terpenoids or steroids will find in this admirable volume a most welcome opportunity to see what advances have been made recently in all the related branches of research."—*G. D. Meakins*, reviewing Volume 1 in *Nature*. 400pp (still available: Vols. 1—4)

Carbohydrate Chemistry Vol. 8

Senior Reporter:
Prof. J. S. BRIMACOMBE
University of Dundee

"The coverage of the literature is excellent, and the content of the papers listed is summarized in an effective manner. Schemes, formulas and diagrammatic representations are widely used to facilitate comprehension."—*Journal of the American Chemical Society*, reviewing Vol. 4. 498pp (still available: Vols. 1—7)